

PARAMAGNETIC DETECTOR ANALYZER MODULE

Rosemount Analytical



NOTICE

The information contained in this document is subject to change without notice.

Rosemount Analytical's system of NGA 2000 Modular Gas Analyzers and Controllers are patented,
under U.S. Patent 5.787.015.

Viton-A® is a registered trademark of E.I. duPont de Nemours & Co.
Paliney No. 7™ is a trademark of J.M. Ney Co.

Manual Part Number 748361-C
December 1998
Printed in U.S.A.

Rosemount Analytical Inc.
4125 East La Palma Avenue
Anaheim, California 92807-1802

CONTENTS

PREFACE

PURPOSE/SAFETY SUMMARY	P-1
GLOSSARY	P-5
SPECIFICATIONS.....	P-7
SPECIFICATIONS - SAMPLE	P-7
SPECIFICATIONS - PHYSICAL.....	P-7
CUSTOMER SERVICE, TECHNICAL ASSISTANCE AND FIELD SERVICE ...	P-8
RETURNING PARTS TO THE FACTORY	P-8
TRAINING	P-8
DOCUMENTATION	P-8
COMPLIANCES	P-9

SECTION 1. INTRODUCTION

1.1 OVERVIEW	1-1
1.2 TYPICAL APPLICATIONS	1-1
1.3 THEORY OF TECHNOLOGY.....	1-1
1.4 FEATURES	1-2

SECTION 2. INSTALLATION

2.1 UNPACKING	2-1
2.2 ASSEMBLY	2-1
2.3 LOCATION	2-2
2.4 GASES	2-2
2.4.1 Requirements.....	2-2
2.4.2 Connections.....	2-5
2.4.3 Leak Test	2-5
2.5 ELECTRICAL CONNECTIONS	2-5

SECTION 3. STARTUP AND OPERATION

3.1	OVERVIEW	3-1
3.2	DISPLAYS	3-1

SECTION 3. STARTUP AND OPERATION (CONTINUED)

3.3	RUN MODE DISPLAY	3-1
3.4	MENU DISPLAYS	3-1
3.5	HELP DISPLAYS	3-2
3.6	STARTUP PROCEDURE	3-5
3.7	BINDING	3-5
3.8	CALIBRATION	3-5
3.9	BACKGROUND GAS COMPENSATION	3-7
3.10	BAROMETRIC PRESSURE COMPENSATION	3-10

SECTION 4. MAINTENANCE AND TROUBLESHOOTING

4.1	OVERVIEW	4-1
4.2	PRINTED CIRCUIT BOARD REPLACEMENT	4-1
4.3	MODULE FAN REPLACEMENT	4-2
4.4	THERMAL FUSE REPLACEMENT	4-3
4.5	FLOW SENSOR REPLACEMENT	4-4
4.6	POWER FUSE REPLACEMENT	4-4

SECTION 5. REPLACEMENT PARTS

5.1	REPLACEMENT PARTS	5-1
-----	-------------------------	-----

APPENDIX A. PMD IDENTIFICATION MATRIX

GENERAL PRECAUTIONS FOR HANDLING AND STORING HIGH PRESSURE CYLINDERS
WARRANTY
FIELD SERVICE AND REPAIR FACILITIES

FIGURES

1-1	Spherical Body in Non-Uniform Magnetic Field	1-2
1-2	Paramagnetic Detector Technology	1-3
2-1	Analyzer Module Installation into Instrument Platform	2-1
2-2	PMD Front Panel Connections	2-4
2-3	PMD Back Panel Connections	2-4
2-4	Interconnection of Typical Gas Manifold to PMD Analyzer Module.....	2-5
2-5	PMD Wiring Diagram.....	2-6
2-6	Outline and Mounting Dimensions.....	2-7
3-1	Run Mode Display	3-3
3-2	Main Menu Display	3-3
3-3	Basic Controls Menu	3-3
3-4	Expert Controls and Setup Menu	3-4
3-5	Technical Level Configuration Menu	3-4
3-6	Typical Help Screen	3-4
3-7	Display Screens (1 of 5)	3-10
3-8	Display Screens (2 of 5)	3-11
3-9	Display Screens (3 of 5)	3-12
3-10	Display Screens (4 of 5)	3-13
3-11	Display Screens (5 of 5)	3-14
4-1	PMD Module - Major Components	4-2
4-2	Module Fan Assembly	4-2
4-3	Detector Assembly	4-3

TABLES

3-1	PMD Analyzer Module Alarms.....	3-2
3-2	Calibration Range for Various Zero Bases Operating Ranges	3-6
3-3	Oxygen Equivalents of Common Gases.....	3-9

NOTES

PREFACE

PURPOSE/SAFETY SUMMARY

The purpose of this manual is to provide the procedures for the installation, operation and maintenance of this NGA 2000 module.

Some sections may describe equipment not used in your NGA 2000 system configuration. The user should become thoroughly familiar with the operation of this module before operating it. Read this instruction manual completely.

To avoid explosion, loss of life, personal injury and damage to this equipment and on-site property, all personnel authorized to install, operate and service the this equipment should be thoroughly familiar with and strictly follow the instructions in this manual. SAVE THESE INSTRUCTIONS.

If this equipment is used in a manner not specified in these instructions, protective systems may be impaired.

DANGER is used to indicate the presence of a hazard which **will** cause **severe** personal injury, death, or substantial property damage if the warning is ignored

WARNING is used to indicate the presence of a hazard which **can** cause **severe** personal injury, death, or substantial property damage if the warning is ignored.

CAUTION is used to indicate the presence of a hazard which **will** or **can** cause **minor** personal injury or property damage if the warning is ignored.

NOTE is used to indicate installation, operation, or maintenance information which is important but not hazard-related.



WARNING: ELECTRICAL SHOCK HAZARD

Do not operate without covers secure. Servicing requires access to live parts which can cause death or serious injury. Refer servicing to qualified personnel.

For safety and proper performance this instrument must be connected to a properly grounded three-wire source of power.



WARNING: POSSIBLE EXPLOSION HAZARD

This equipment is not designed for and should not be used in the analysis of flammable samples. Use of this equipment in this way could result in explosion and death.

Note

Apply leak test liquid to cell or detectors only as a last resort.



WARNING: POSSIBLE EXPLOSION HAZARD

Verify that all gas connections are made as labeled and are leak free. Improper gas connections could result in explosion or death. See Section 2.4.3 for Leak test procedure.



WARNING: PARTS INTEGRITY

Tampering or unauthorized substitution of components may adversely affect safety of this product. Use only factory documented components for repair



WARNING: OVER-VOLTAGE SPIKING

If this Analyzer Module is used with a non-Rosemount Analytical power supply, adding Rosemount Analytical PN 90331 Current Protector in series with the 24 V positive line will prevent over-voltage spiking and resultant fuse blowing when powering up the instrument.



CAUTION: PRESSURIZED GAS

This module requires periodic calibration with a known standard gas. See General Precautions for Handling and Storing High Pressure Gas Cylinders in the rear of this manual.

**CAUTION: HAND INJURY HAZARD**

Do not place hands or fingers in Platform front handles when the front panel is open. Dropping front panel while hand or fingers are inside either handle can cause serious injury.

**CAUTION: OVERBALANCE HAZARD**

This Analyzer Module may tip instrument over if it is pulled out too far and the Platform is not properly supported.

NOTES

GLOSSARY

ANALYZER MODULE

Self contained analysis modules that are designed to be installed into the NGA 2000 System. One Analyzer Module can be installed into a Single Enclosure containing the Platform Module. Two Analyzer Modules can be installed into a Dual Enclosure. The simplest NGA 2000 System consists of one Analyzer Module.

BACKPLANE

The interconnect circuit board which the Controller Board, Power Supply Board, I/O Board(s) and Expansion Board(s) are plugged into the Backplane

CONTROL MODULE

The operator interface plus the Controller Board.

CONTROLLER BOARD

The Controller Board in the Platform which runs the software program that operates the Display, Keypad and Network Manager. The Controller Board plugs into the Backplane.

DISTRIBUTION ASSEMBLY

The Distribution Assembly consists of the Backplane and the card cages in the Platform Module that contain I/O Module(s) and Expansion Module(s).

EXPANSION BOARD

The Expansion Board performs special features not related to I/O functions. The Expansion Board plugs into the Backplane from the Platform front.

I/O MODULE

An auxiliary module that provides some sort of interface to the outside world. I/O modules may include analog outputs, relay contacts, and digital interfaces. In general, they are mounted in platforms as options.

OPERATOR INTERFACE

The Display and Keyboard of the Platform.

PLATFORM

Any combination of the NGA case, the display and computer board, power supply, and I/O modules. In general, it could be considered to be anything in the NGA system other than the analyzer modules.

POWER SUPPLY

Any of a variety of components that provide conditioned power to other NGA 2000 components, from the Power Supply Board that plugs into the Backplane in a stand-alone instrument to several larger ones that can power larger collections of modules and components.

PRIMARY VARIABLE

The measured species concentration value from an Analyzer Module.

SECONDARY VARIABLE

The current status data placed on the network by an Analyzer Module. This includes sample flow, source voltage and other diagnostic information.

SOFTKEYS

The five function keys located below the front panel display. The menu function for each softkey is displayed directly above it and is controlled by the software.

SYSTEM

A NGA 2000 System consisting of one (or more) Analyzer Modules, an optional Platform, one or more optional I/O Boards, an optional Expansion Board and an optional Supplemental Power Supply.

SPECIFICATIONS

MEASUREMENT SPECIES:	Oxygen
RANGES:	0 to 100% oxygen; four fullscale selections, including suppressed zero ranges in 1% increments
REPEATABILITY:	±1% of fullscale (at constant temperature)
MINIMUM DETECTABLE LEVEL:	0.01% oxygen
NOISE:	<1% of fullscale, peak-to-peak; <±1% for suppressed ranges
LINEARITY:	±1% of fullscale
RESPONSE TIME:	0 to 90% of fullscale in 20 seconds (±2 seconds)
DRIFT (ZERO AND SPAN):	<±1% of fullscale/24 hours, <±2% of fullscale/week at constant temperature; <±2% of fullscale/24 hours, <±4% of fullscale/week of range for 99 to 100% (at constant temperature)
EFFECT OF TEMPERATURE:	<±1% of fullscale over any 10°C interval for rate of change no greater than 10°C per hour
ENVIRONMENT:	Location - Class B controlled, indoor, non-hazardous
AMBIENT TEMPERATURE:	0 to 45°C (32 to 113°F)
EFFECT OF FLOW:	<±1% of range when sample flow rate is changed by 20 ml/min.
POWER REQUIREMENTS:	24 VDC ±5%, 50 W max.; ripple and noise: <100 mV peak-to-peak; line and load regulations: <±1%

SPECIFICATIONS – SAMPLE

TEMPERATURE:	Non-flammable;; 10 to 66°C (50 to 150°F)
FLOW RATE:	800 to 1400 ml/min.
EXHAUST PRESSURE:	-345 to 690 hPa-gauge (-5 to 10 psig)
PARTICLES:	filtered to <2 microns
DEWPOINT:	below 43°C (110°F), no entrained liquid
MATERIALS IN CONTACT WITH SAMPLE:	Glass, 316 stainless steel, titanium, Paliney No. 7, epoxy resin, Viton A, platinum, nickel, rhodium and MgF ₂

SPECIFICATIONS - PHYSICAL

CASE CLASSIFICATION:	General purpose for installation in weather-protected areas
DIMENSIONS:	See Outline and Mounting Dimensions, Figure 2-4
WEIGHT:	8 kg (17.6 lbs.)
MOUNTING:	Inside a Platform or custom-installed in a panel
MAXIMUM LENGTH OF LON CABLE:	1600 m (1 mile) between Analyzer Module and Platform

See the Preface section of the Platform Components manual for specifications regarding Platform-related components (e.g., case dimensions) and the Preface of the I/O Module manual for specifications regarding I/O (e.g., relay outputs).

CUSTOMER SERVICE, TECHNICAL ASSISTANCE AND FIELD SERVICE

For order administration, replacement Parts, application assistance, on-site or factory repair, service or maintenance contract information, contact:

**Rosemount Analytical Inc.
Process Analytical Division
Customer Service Center
1-800-433-6076**

RETURNING PARTS TO THE FACTORY

Before returning parts, contact the Customer Service Center and request a Returned Materials Authorization (RMA) number. Please have the following information when you call: *Model Number, Serial Number, and Purchase Order Number or Sales Order Number.*

Prior authorization by the factory must be obtained before returned materials will be accepted. Unauthorized returns will be returned to the sender, freight collect.

When returning any product or component that has been exposed to a toxic, corrosive or other hazardous material or used in such a hazardous environment, the user must attach an appropriate Material Safety Data Sheet (M.S.D.S.) or a written certification that the material has been decontaminated, disinfected and/or detoxified.

Return to:

**Rosemount Analytical Inc.
4125 East La Palma Avenue
Anaheim, California 92807-1802**

TRAINING

A comprehensive Factory Training Program of operator and service classes is available. For a copy of the *Current Operator and Service Training Schedule* contact the Technical Services Department at:

**Rosemount Analytical Inc.
Phone: 1-718-986-7600
FAX: 1-714-577-8006**

DOCUMENTATION

The following NGA 2000 Paramagnetic Detector instruction materials are available. Contact Customer Service or the local representative to order.

748361 Instruction Manual (this document)

COMPLIANCES

This product may carry approvals from several certifying agencies, including Factory Mutual and the Canadian Standards Association (which is also an OSHA accredited, Nationally Recognized Testing Laboratory), for use in non-hazardous, indoor locations



Rosemount Analytical Inc. has satisfied all obligations from the European Legislation to harmonize the product requirements in Europe.



This product complies with the standard level of NAMUR EMC Recommendation (May 1993).



This product satisfies all obligations of all relevant standards of the EMC framework in Australia and New Zealand.



NOTES

1 INTRODUCTION

1.1 OVERVIEW

This manual describes the Paramagnetic Detector (PMD) Analyzer Module of Rosemount Analytical's NGA 200 Series of gas analysis components.

The PMD Analyzer Module is designed to continuously determine the concentration of oxygen in a flowing gaseous mixture. The concentration is expressed in ppm or percent volume O₂.

The entire Analyzer Module is designed as a slide-in module (if configured in stand-alone instrument fashion), removable from the front of the Platform, with gas connections made from the rear. All electronics relative to sample detection and conditioning are included in this module.

1.2 TYPICAL APPLICATIONS

PMD Analyzer Module applications include:

- process control
- continuous emissions monitoring systems (CEMS)
- industrial gas production
- fermentation process monitoring

1.3 THEORY OF TECHNOLOGY

Oxygen is strongly paramagnetic (i.e., capable of becoming a temporary magnet when placed in a magnetic field) while most other common gases are weakly diamagnetic (i.e., tend to be non-magnetic). See Figure 1-1.

The Magnetic susceptibility of the flowing gas sample is sensed in the detector/magnet assembly. As shown in Figure 1-2, a dumbbell shaped, nitrogen-filled, hollow gas test body is suspended on a platinum/nickel alloy ribbon in a non-uniform magnetic field.

Because of a "magnetic buoyancy" effect, the spheres of the test body are subjected to displacement forces, resulting in a displacement torque proportional to the magnetic susceptibility of the gas surrounding the test body.

Measurement is accomplished by a null-balance system, whereby the displacement torque is opposed by an equal and opposite restorative torque.

The restoring current is automatically maintained at the correct level by an electro-optical feedback system. A beam of light from the source LED is reflected off the square mirror attached to the test body onto a bi-cell (dual photodiode).

The current required to keep the test body to the null position is a linear function of the total magnetic susceptibility of the sample gas.

See Figures 4-1, 4-2, and 4-3 for component configuration.

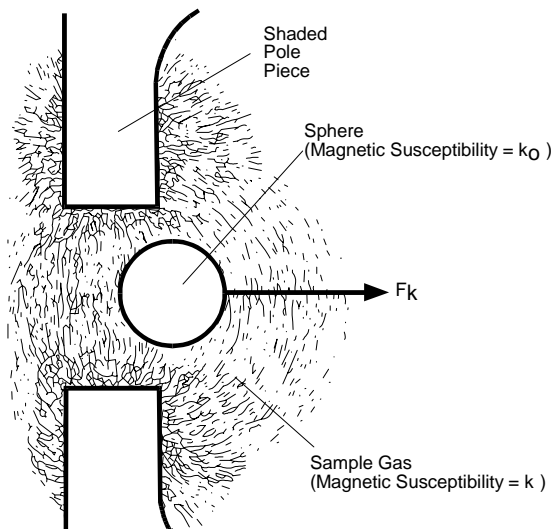

Note:
As percentage of oxygen in sample gas increases,
displacement force (F_k) increases.

FIGURE 1-1. SPHERICAL BODY IN NON-UNIFORM MAGNETIC FIELD

1.4 FEATURES

Among the features incorporated into the PMD Analyzer Module is a flow splitter ($\approx 2:1$) that allows for greater sample flow, decreased lag time and faster analyzer response.

The "Time Alignment" feature can be used to delay sending the Primary Variable from the PMD Analyzer Module for up to 30 seconds in 0.1 second intervals. This feature allows Primary Variables from more than one PMD Analyzer Module to be "time aligned" if necessary.

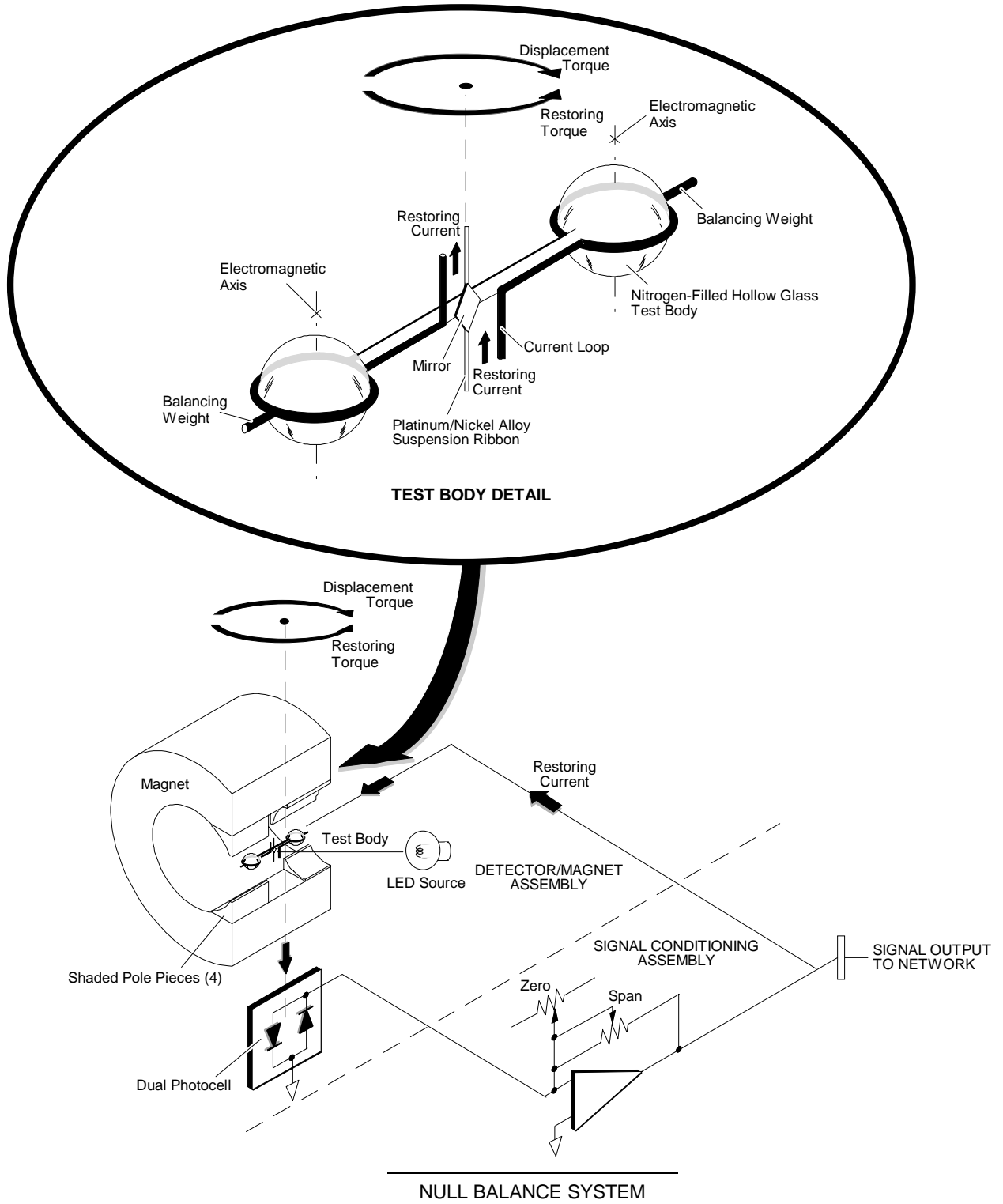

FIGURE 1-2. PARAMAGNETIC DETECTOR TECHNOLOGY

NOTES

2 INSTALLATION

2.1 UNPACKING

If the Paramagnetic Analyzer Module is received as a separate unit, carefully examine the shipping carton and contents for signs of damage. Immediately notify the shipping carrier if the carton or contents is damaged. Retain the carton and packing material until all components associated with the Analyzer Module are operational.

2.2 ASSEMBLY

If the Analyzer Module requires assembly with other components (e.g., the Platform and associated I/O Modules), do so at this time. Following the guides on the bottom left and bottom center of the Platform, carefully slide the Analyzer Module halfway into place.



WARNING: HAND INJURY HAZARD

Do not place hands or fingers in the Platform front handles when front panel is open. Dropping the front panel of the Platform while hand or fingers are inside either handle can cause serious injury.

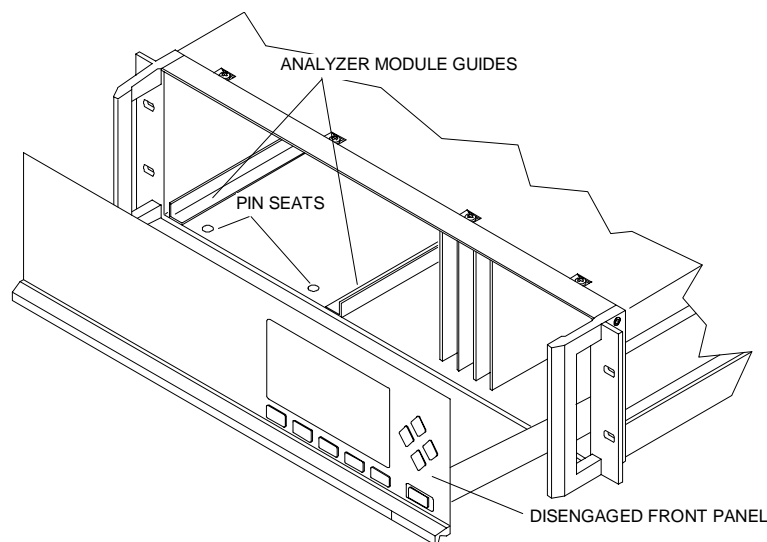

FIGURE 2-1. ANALYZER MODULE INSTALLATION INTO INSTRUMENT PLATFORM

Lift the spring-loaded pins on the front of the Analyzer Module, and carefully slide it the rest of the distance. Secure the module in position by releasing the pins, which seat in the available holes in the bottom of the case (see Figure 2-1). If the module and Platform are difficult to assemble, remove the module, ensure the top cover of the module is firmly seated on the hold-down screws, and repeat the assembly procedure.

Install I/O Module(s) according to guidelines in the I/O manual. After startup and calibration have been performed, secure the front panel with the six screws provided.

2.3 LOCATION

Install the Analyzer Module in a clean, non-hazardous, weather protected, vibration free location free from extreme temperature variations. For best results, either install the module near the sample stream to minimize sample transport time or supply a flow greater than necessary and route only the appropriate amount through the Analyzer Module.

Observing these requirements are critical. Note the following:

- Excessive vibration can cause a noisy readout. To minimize vibration effects, the detector/magnet assembly is enveloped in a shock-mounted compartment.
- The user should ensure, when making any internal electrical connections, that no cables are placed in contact with the detector assembly or associated internal sample inlet and outlet tubing.
- Magnetic susceptibilities and partial pressures of gases vary with temperature. Permissible ambient temperature range is 32°F to 113°F (0°C to 45°C).
- The interior of the Detector Assembly is maintained at approximately 144°F (62°C) by an electronically controlled heater. Prior to entering the detector assembly, the sample is heated in a coiled tubing to match the detector's temperature.

2.4 GASES

2.4.1 REQUIREMENTS

CALIBRATION GASES

Analyzer Module calibration requires the establishment of zero and span calibration points. This requires a zero standard gas to set the zero point span gas to establish a calibration point at or near the upper range limit.

An oxygen-free gas, typically nitrogen, is required for use as the zero standard gas. Recommendations for span calibration gases, bases on various operating ranges, are tabulated in Table 3-1. Air (20.93% oxygen) can be used as span gas regardless of the ranges used for sampling, although very low ranges may lose accuracy.

SAMPLE GAS

Sample gas should be non-flammable.

TEMPERATURE

Sample temperature at the inlet should be from 50°F to 150°F (10°C to 66°C). A maximum entry temperature of 110°F (43°C) is recommended to prevent cooling of the sample and possible internal condensation. Such condensation could damage some components of the Analyzer Module. This recommendation can be ignored if a thoroughly dry sample is examined.

PRESSURE

Sample exhaust pressure limits are -5 to 10 psig (-345 to 690 hPa-gauge). Normal operation is in the positive range, between 0 and 10 psig (0 and 690 hPa-gauge). Negative gauge pressures are not normally recommended, but may be used in certain special applications.

To prevent over-pressurization, insert a pressure relief valve into the sample inlet line. A check valve should also be placed in the outlet line if the Analyzer Module is connected to a manifold associated with a flare or other apparatus that does not operate at atmospheric pressure.

The outlet port is commonly vented to the atmosphere. Any change in barometric pressure has a directly proportional effect on the indicated percent of oxygen, and should be neutralized through manual or computer correction of data. Note the following example:

Range = 0% to 5% oxygen

Barometric pressure change after calibration = 1%

Analyzer Module measurement = 5% oxygen

Measurement error = 0.01 x 5% oxygen

Fullscale span = 5% oxygen

0.05% oxygen error = 1% of fullscale

The error is more significant for suppressed range 99% to 100%.

An optional barometric pressure compensation board is available to automatically perform this correction.

A general rule regarding calibration gas pressure is that it should be the same as the expected sample gas pressure during routine operation.

The above requirement increases the difficulty of operation at negative gauge pressure. A suction pump can be connected to the outlet port for drawing sample through the Analyzer Module. Such operation necessitates special precautions to ensure accurate readout, including the following:

The need for equilibrium between sample and gas calibration pressures.

Any leakage in the sample handling system will decrease readout accuracy.

FLOW RATE

Recommended sample flow rate is 800 to 1400 ml/min., ± 40 ml/min. Optimum flow rate is 1100 ml/min.

If flow is held to within tolerance and operating pressure remains constant, zero and span drift will meet specified limits.

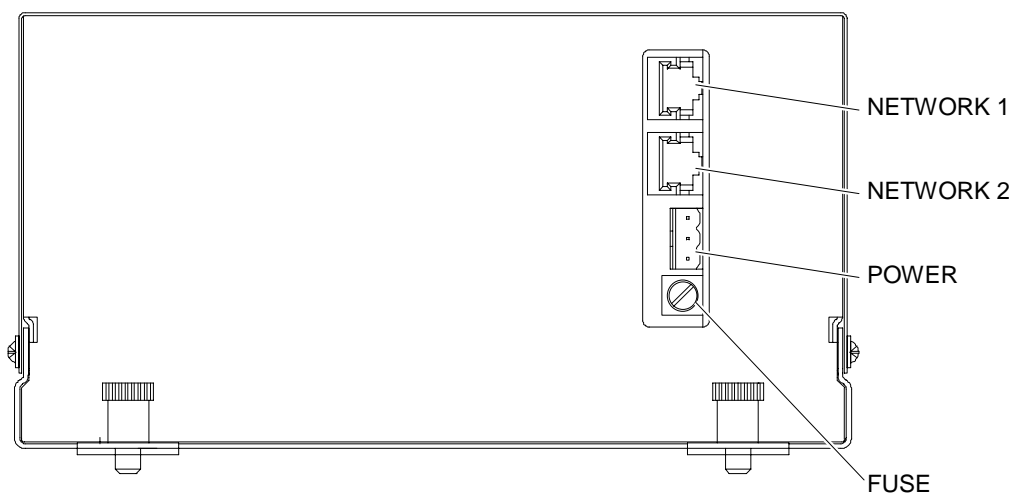
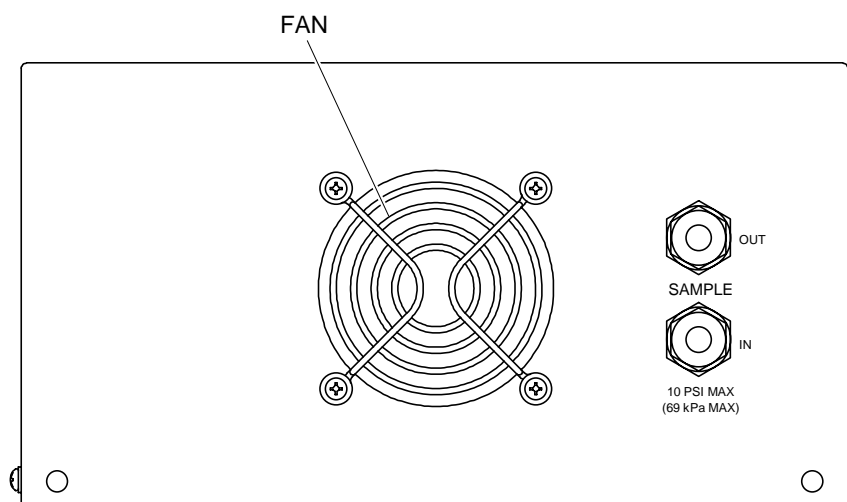

FIGURE 2-2. PMD FRONT PANEL CONNECTIONS



Note: Reference and purge gas connections are applicable only to certain applications.

FIGURE 2-3. PMD BACK PANEL CONNECTIONS

2.4.2 CONNECTIONS

(See Figure 2-3) Connect inlet and outlet lines for sample gas to appropriately labeled fittings on the rear panel. Both connections are 1/4 inch ferrule-type compression fittings.

Zero and span gases use the same inlet and outlet as the sample. Figure 2-4 shows a typical external sample handling manifold for gas selection. Particulates must be filtered down to two microns, gases generally require pressurization, and flow measurement metering **MUST** be present.

2.4.3 LEAK TEST

The Analyzer Module is thoroughly tested at the factory for gas leakage. The user is responsible for testing for leakage only at the inlet and outlet fittings on the rear panel. The user is also responsible for internal leak testing periodically and if any internal pneumatic components are adjusted or replaced (with a test procedure selected by the user).

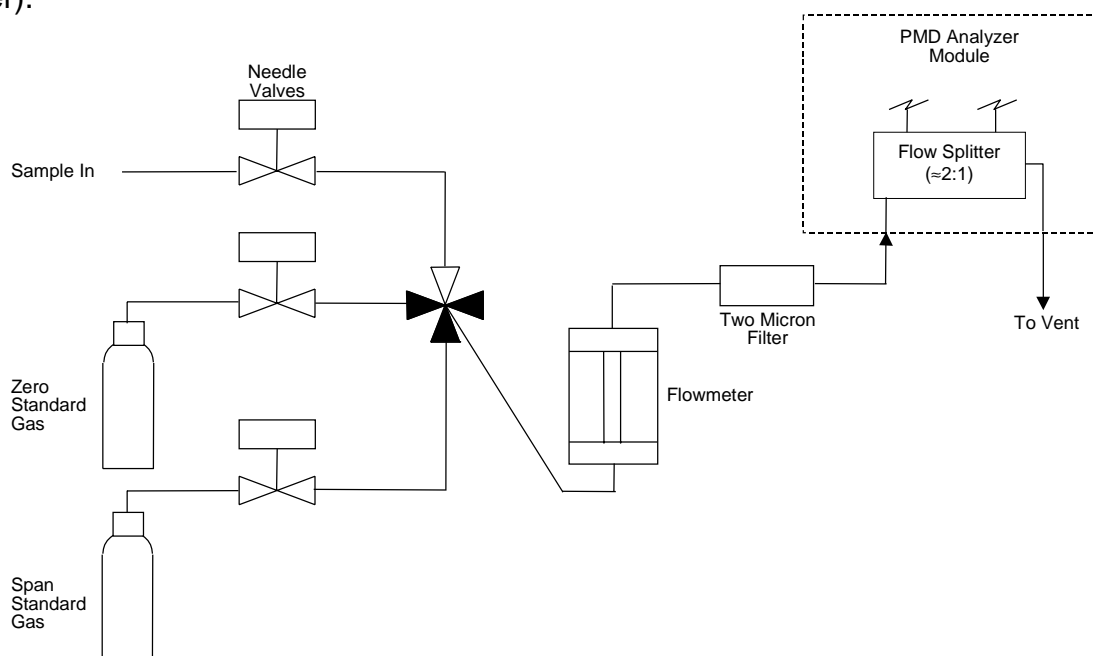

FIGURE 2-4. INTERCONNECTION OF TYPICAL GAS MANIFOLD TO PMD ANALYZER MODULE

2.5 ELECTRICAL CONNECTIONS

Note

Electrical connections must be in compliance with National Electrical Code (ANSI/NFPA 70) and/or any applicable national or electrical codes.

Two electrical connections are required on the Analyzer Module; POWER and

NETWORK. See Figure 2-2. On the Analyzer Module, two NETWORK connections are available, either of which is appropriate for : 1) interconnection with Backplane of the Platform (see Platform instruction manual) or 2) "daisy chaining" with other NGA 2000 components.

Connect Analyzer Module POWER 24 VDC power source, either the Platform or external power source.

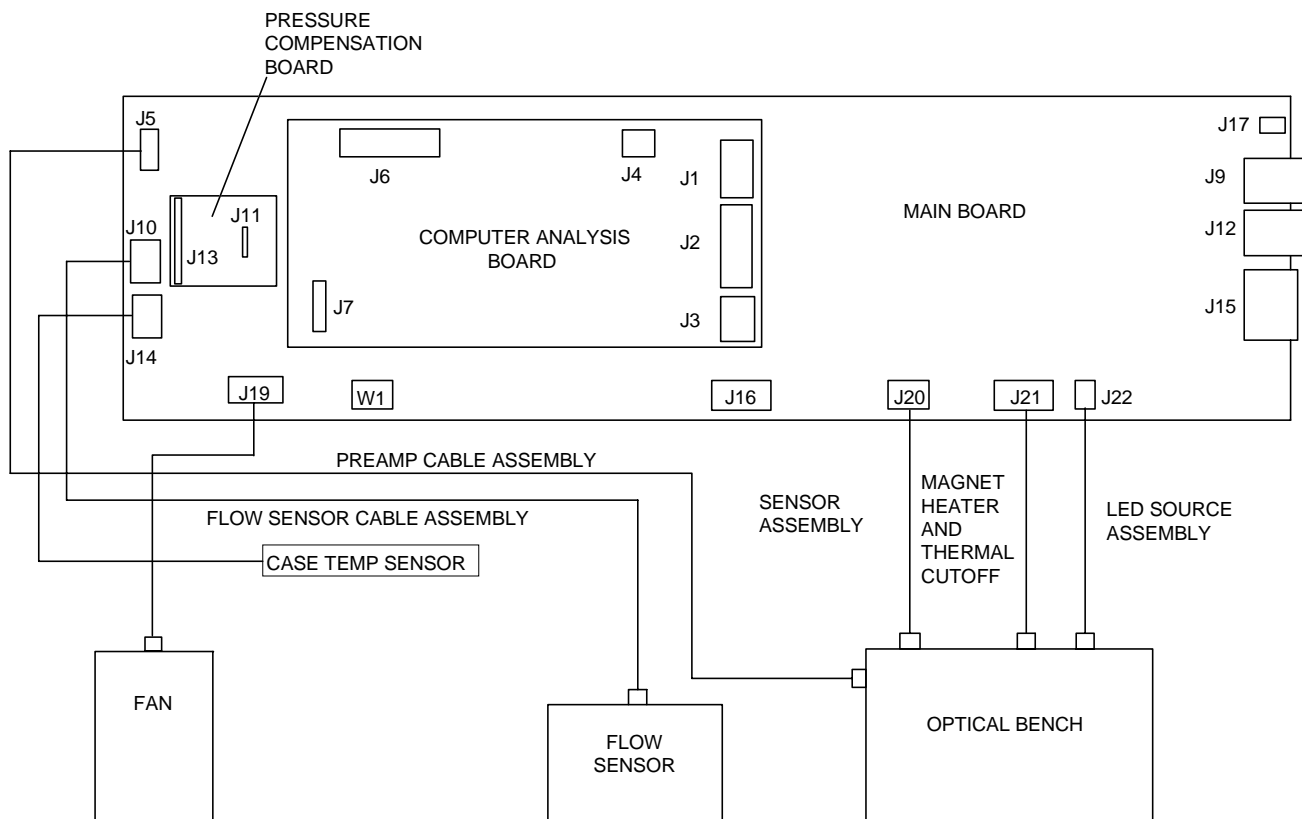
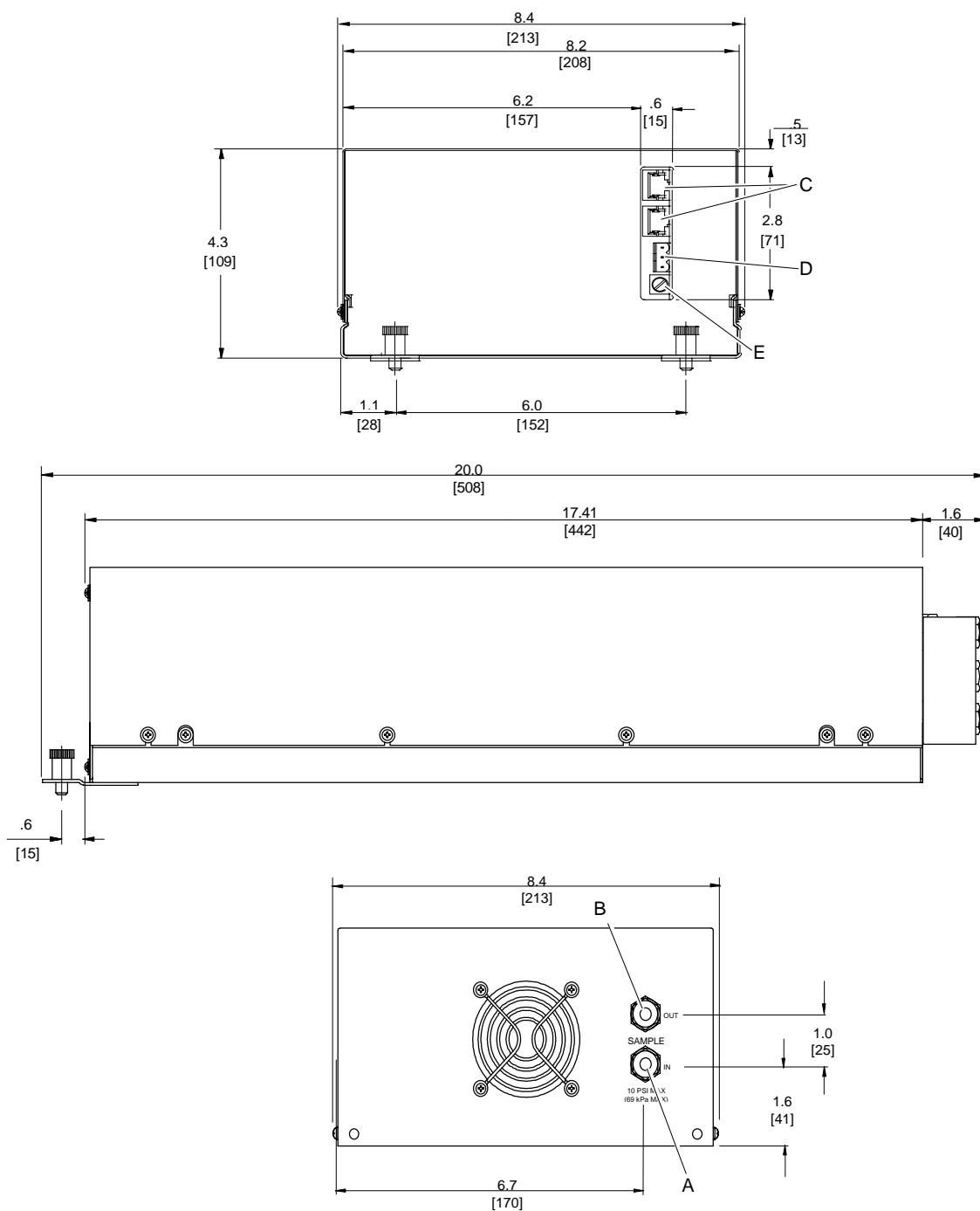

FIGURE 2-5. PMD WIRING DIAGRAM



- E. FUSE.
- D. POWER CABLE TO NETWORK.
- C. NETWORK CABLE CONNECTIONS TO PLATFORM.
- B. SAMPLE OUT: 1/4" O.D. TUBE FITTING.
- A. SAMPLE IN: 1/4" O.D. TUBE FITTING.

5. MODULE TO BE INSTALLED WITHIN $\pm 15^\circ$ OF HORIZONTAL.
4. POWER REQUIREMENTS: 24 VDC 3.5 A.
3. ELECTRICAL INSTALLATION MUST BE IN COMPLIANCE WITH NATIONAL ELECTRICAL CODE (ANSI/NFPA 70) AND/OR ANY APPLICABLE NATIONAL OR LOCAL CODES.
2. MODULE IS NOT WEATHERPROOF.
1. APPROXIMATE WEIGHT: 15 LB (6.8 kg).

DIMENSIONS	
INCH	[mm]

FIGURE 2-6 OUTLINE AND MOUNTING DIMENSIONS

NOTES

3 STARTUP AND OPERATION

3.1 OVERVIEW

Prior to initial startup, the user should perform the leak test procedure outlined in Section 2.

For the remainder of this section Analyzer Module interconnection with a Platform or some interfacing component will be assumed. Display and keypad information shall refer to that which the user can expect to see and do with regard to the front panel of the Platform.

For a complete description of the Platform front panel controls and indicators, see the Platform instruction manual.

3.2 DISPLAYS

Three kinds of Display screens are available to the user:

- Run Mode
- Menu
- Help

3.3 RUN MODE DISPLAY

The Run Mode is the normal mode of operation. In this mode, the Display (see Figure 3-1) will show current gas measurement, the component of interest, the current operations of the softkeys, and a graphic bar representing the displayed concentration as ppm or as a percent of oxygen.

If more than one Analyzer Module is connected to the system, the Run Mode display will show as many as four gas measurements on screen. Alarm messages may also appear on the display (See Table 3-1).

3.4 MENU DISPLAYS

The menu structure enables the user to access data and functions, and put information onto the network.

MESSAGE DISPLAY	DESCRIPTION	TYPE
BAROMETER	System Barometer	WARNING
CASE TEMP	Case Temperature	WARNING
CRUDE NOISE	Calculated Noise	WARNING
CURRENTRNGHI	Current, High Range	WARNING
CURRENTRNGLO	Current, Low Range	WARNING
DET TEM	Detector Temperature	WARNING
FAN FET	Fan Current	WARNING
HEATER FET	Heater Current	WARNING
LED CURRENT	LED Current	WARNING
LIN ERROR	Linearizer Error	WARNING
LOOP CURRENT	PMD Loop Current	WARNING
N15 VOLTS	Power Supply, -15V	WARNING
P15 VOLTS	Power Supply, +15V	WARNING
P24 VOLTS	Power Supply, +24V	WARNING
P5 VOLTS	Power Supply, +5v	WARNING
RAW SIGNAL	Raw Signal	WARNING
SAMP PRES	Sample Pressure	WARNING
SVFLOW	Sample Bypass Flow	WARNING
BICELLA	PMD Photo Sensor	FAILURE
BICELLB	PMD Photo Sensor	FAILURE
SW ERROR	Software Error	FAILURE

TABLE 3-1. PMD ANALYZER MODULE ALARMS

The Main Menu (Figure 3-2) is subdivided into three levels of control based generally on which personnel is likely to use it: Basic Controls, Expert Controls and Setup, and Technical Level Configuration. See Figures 3-3, 3-4, and 3-5. Many layers of the menu structure are described at appropriate places throughout this manual.

From the Run Mode display, press the MENU softkey to enter the Main Menu (Figure 3-2).

See Figures 3-7 through 3-11 for flow charts depicting Menu screens related to this Analyzer Module.

3.5 HELP DISPLAYS

The Help structure is intended to be an on-line "tutorial," context sensitive and topic-interconnected, so that the user can practically operate NGA 2000 without need of an instruction manual (Figure 3-6).

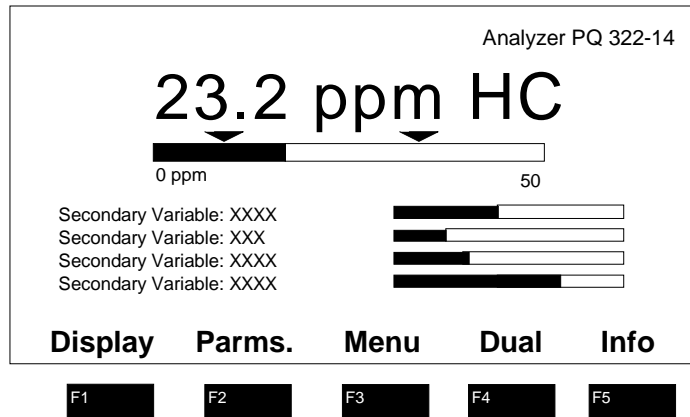

FIGURE 3-1. RUN MODE DISPLAY

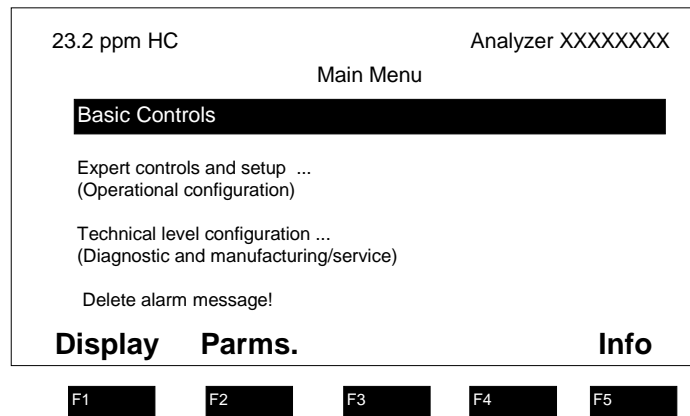

FIGURE 3-2. MAIN MENU DISPLAY

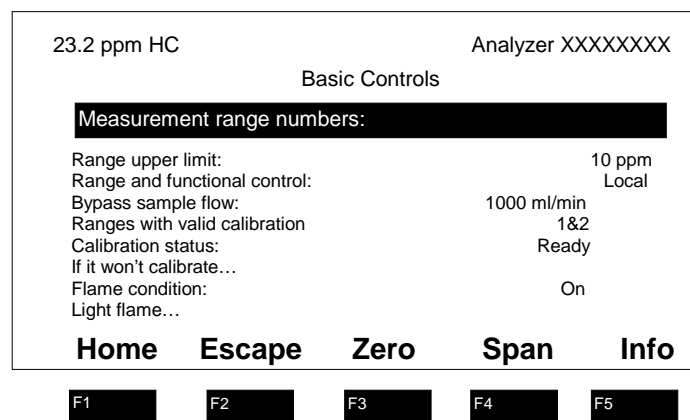

FIGURE 3-3. BASIC CONTROLS MENU

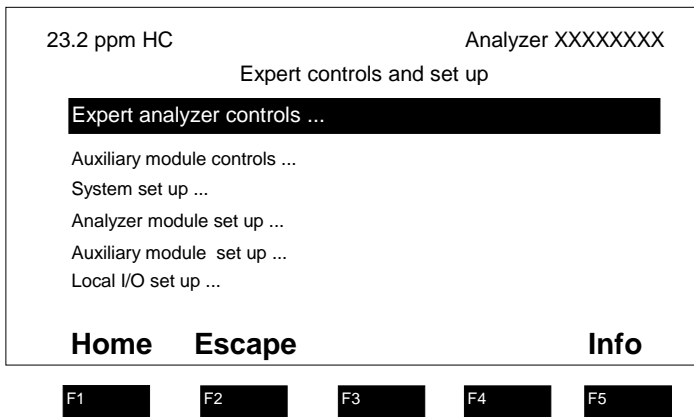

FIGURE 3-4. EXPERT CONTROLS AND SETUP MENU

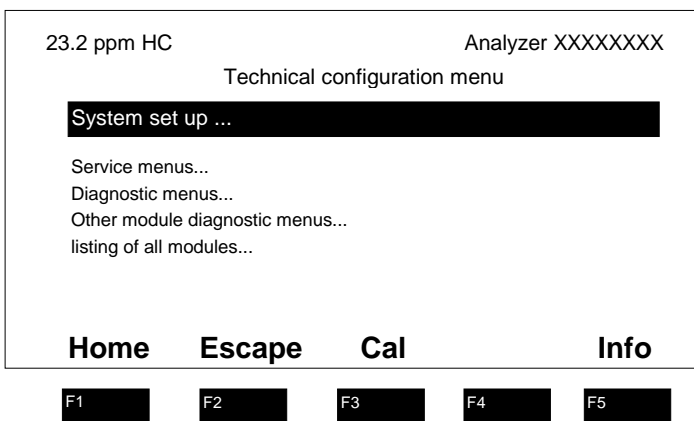

FIGURE 3-5. TECHNICAL LEVEL CONFIGURATION MENU

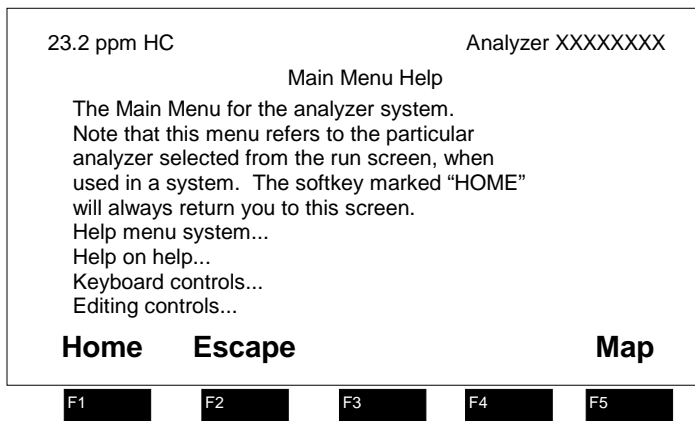

FIGURE 3-6. TYPICAL HELP SCREEN

3.6 STARTUP PROCEDURE

Introduce a suitable on-scale gas (NOT actual sample) into sample inlet.

Apply power to the PMD Analyzer Module. If it is associated with a Platform, do this by plugging in the Platform to a power source. The Platform has no ON/OFF power switch. Once power is supplied to the Platform, the PMD Analyzer Module will be energized.

If the user's system contains only one Analyzer Module, all system components, the Controller Board and the network "self-install" (bind together) during initial startup. If the system contains more than one Analyzer Module, the startup sequence will interrogate the network to locate and identify all components on the network. The user will have to bind appropriate combinations of components after the startup sequence.

After the warm-up period, approximately one hour for PMD Module, all modules are completely functional.

Enter appropriate data in the Calibration Gas List (by making the following display selections: Main Menu, Expert Controls and Setup [enter security code, if necessary], Analyzer Module setup, Calibration Gas List). Also, enter appropriate values in the Calibration Parameters menu (by making the following display selections: Main Menu, Expert Controls and Setup [enter security code, if necessary], Analyzer Module Setup, Calibration Parameters), particularly data related to which ranges are to be zeroed together and how the Analyzer Module is expected to calibrate ranges (separately or otherwise).

The Analyzer Module will not allow the user to increase the upper limit of a range beyond the "maximum range" software setting. To change the "maximum range" value, select the following from the Main Menu: Technical Configuration Menu, Service Menu, Manufacturing Data, Analyzer Module Data. Select Maximum Range, and use the arrow keys to scroll the indicated value. The same applies for "minimum range" settings.

3.7 BINDING

To achieve full coordination between Analyzer Modules and associated I/O Modules, the user must bind those components together in the System Setup portion of the Technical Configuration Menu in software. See Figure 3-10 of this manual and Section 1.5 of the I/O Modules Manual for binding instructions.

3.8 CALIBRATION

Calibration consists of establishing zero and span calibration points. Generally, zero and span calibration should be performed on the range that will be used during sample analysis.

To calibrate the PMD Analyzer Module, introduce zero gas into the SAMPLE INLET, and do the following:

1. If the *Multi-Analyzer Module*, split *Run Mode* display is shown, press the *DISPLAY* softkey until the desired Analyzer's *Run Mode* display is acquired.
2. Press the *MENUS* softkey to enter the *Main Menu*.
3. Press the *ENTER* key to enter the *Basic Controls menu*.
4. Press the *ZERO* softkey to enter the *Analyzer Zero menu*.
5. Press the *ZERO* softkey and wait.
6. Introduce span gas (Table 3-2) into the SAMPLE INLET.
7. Press the *SPAN* softkey to enter the *Analyzer Span menu*, press *SPAN* again and wait.
8. Press the *HOME* softkey to re-enter the *Main Menu*.
9. Press the *DISPLAY* softkey for the *Run Mode* display.

RANGE % OXYGEN	RECOMMENDED ZERO STANDARD GAS	RECOMMENDED SPAN STANDARD GAS
0 to 1	Nitrogen	0.9% O ₂ , balance N ₂
0 to 2.5	Nitrogen	2.3% O ₂ , balance N ₂
0 to 5	Nitrogen	4.5% O ₂ , balance N ₂
0 to 10	Nitrogen	9% O ₂ , balance N ₂
0 to 25	Nitrogen	Air (20.93% O ₂)
0 to 50	Nitrogen	45% O ₂ , balance N ₂
0 to 100	Nitrogen	100% O ₂

TABLE 3-2. CALIBRATION RANGE FOR VARIOUS ZERO BASED OPERATING RANGES

If the user is unable to calibrate the Analyzer Module (i.e., when ZERO or SPAN is initiated, nothing happens), a possible solution relates to the use of an incorrect gas for zeroing or spanning (e.g., using a high concentration gas to zero or a zero gas to span the Analyzer Module). Recalibrating with the appropriate gas(es) WILL NOT correct the problem because the ZERO OFFSET or SPAN FACTOR has been set to an extreme value in the process.

To remedy the problem, do the following:

1. Select the following from the Main Menu: Expert Controls and Setup (enter security code if necessary), Analyzer Module Setup, and Calibration Parameters.
2. Using the down arrow, select Zero Ranges, press ENTER and, using the up/down arrows, toggle to SEPARATE. Do the same for the Span Ranges selection. Do not press ESCAPE at any time unless retention of prior settings is desired.
3. Return to the Main Menu (HOME) and make the following selections: Expert

Controls and Setup (enter security code if necessary), Expert Analyzer Controls, CAL softkey, FACTORS softkey, and Range 1 (2, 3, 4) Factors. (Do steps 4 and 5 for each range.)

4. Select Zero Offset, press ENTER, adjust the value to 525000 with the up/down arrow keys, and press ENTER. Do not press ESCAPE at any time unless retention of prior settings is desired.
5. Select Span Factor, press ENTER, adjust the value to 0.000015 with the up/down arrow keys, and press ENTER. Do not press ESCAPE unless retention of prior settings is desired.
6. Attempt to recalibrate the Analyzer Module according to the procedure outlined at the beginning of Section 3.8. If re-calibration fails, return to the Range Factors menu, readjust factors, and attempt calibration again.

3.9 BACKGROUND GAS COMPENSATION

Any gas having a composition other than 100% oxygen contains background gas, that is, non-oxygen components. Sometimes, the PMD Module response to background gas is significant, depending largely on the span and range used.

If the operator uses zero and span gases that contain the same background gas as the sample, calibration procedures automatically compensate. No adjustments are necessary.

If the background gas in the sample is different from that in the zero and/or span gases, the operator must take into consideration background effects to ensure correct readout. During entry of zero and span gas values in the Calibration Gas List, the instrument is not set to indicate the true oxygen content of the zero and span standard gases. It is set to indicate a slightly different value, relative to background gas, calculated to provide correct readout during subsequent analysis of sample gas.

OXYGEN EQUIVALENT VALUES OF GASES

For computation of background corrections, the analyzer's response to each component of the sample must be known. Table 3-3 lists the percentage oxygen equivalent values for many common gases. For a more comprehensive list of oxygen equivalent values, refer to a resource text such as the Handbook of Chemistry and Physics for tables of magnetic susceptibility of substances. The percentage oxygen equivalent of a gas can be determined by the following equation, assuming both gases are supplied at the same pressure:

$$\% \text{ O}_2 \text{ Equivalent of Gas} = \frac{\text{Analyzer Response to Gas}}{\text{Analyzer Response to O}_2} \times 100\%$$

For example, if the analyzer's response to oxygen is +100%, the response to xenon would be -1.34%.

The oxygen equivalent of a gas mixture is the sum of the contribution of the individual gas components.

Example: Zero Based Range

At lower range limit (i.e., 0% O₂), composition of sample is: 80% CO₂, 20% N₂.

From Table 3-3, the percent oxygen equivalents are: CO₂ -0.623%, N₂ -0.358%.

The percent oxygen equivalent of the mixture =

$$0.8(-0.623) + 0.2(-0.358) = (-0.4984) + (-0.0716) = 0.570\% \text{ O}_2.$$

COMPUTING ADJUSTED VALUES FOR CALIBRATION GAS LIST

Before calibrating the Analyzer Module, values in the Calibration Gas List must be adjusted to correct for magnetic susceptibility of background gas. In the equation that follows, the quantities are defined as follows:

- **BGGst** = oxygen equivalent of background gas in standard gas (Table 3-3).
- **BGGs** = oxygen equivalent of background gas in sample (Table 3-3).
- **OP** = operating pressure. Unless special pressure corrections are to be made, the zero standard, span standard and sample gases must all be admitted at the same pressure.

Use the following equation to compute the adjusted settings for the Calibration Gas List:

$$\text{Adjusted percent oxygen for standard gas} = \frac{(A)[100 + (B-C)] - 100[B-C]}{100}$$

Where:

A = true percent oxygen of standard gas

B = BGGs

C = BGGst

Example:

Background gas in sample is CO₂, oxygen equivalent = -0.623%.

Zero gas is 100% N₂.

Span standard gas is air: 21% O₂, 79% N₂.

Background gas in zero and span standard gases is N₂, oxygen equivalent = 0.358%.

With N₂ zero standard gas flowing, zero gas value in the Calibration Gas List would be 0.265% O₂ (as determined by the following):

$$\frac{0[100+(-0.623-(-0.358))] - 100\{-0.623-(-0.358)\}}{100} = 0.265\% \text{ O}_2$$

With air flowing, span gas value in the Calibration Gas List would be 21.21% oxygen (as determined by the following):

$$\frac{21(100 - 0.265) - 100(-0.265)}{100} = 21.209\% \text{ O}_2 \cong 21.21 \text{ O}_2$$

In two limiting cases, the general equation is reduced to simpler forms.

1. If the span standard gas is 100% oxygen, the adjusted oxygen value is the same as the true value (i.e., 100% O₂).
2. If the zero standard is an oxygen-free zero gas, the adjusted value for setting the ZERO Control = BGGst-BGGs. (If the oxygen-free zero gas is more diamagnetic than the background gas in the sample, this difference is negative. The negative value may be entered in the Calibration Gas List.)

Alternately, the user can avoid these compensation calculations by using zero and span gases which have been specially prepared to contain the expected amounts of background gas. Calibration of the analyzer module will then factor in background gas effects in the same proportions as normal run mode measurement.

GAS	EQUIV. % AS O ₂	GAS	EQUIV. % AS O ₂
Acetylene, C ₂ H ₂	-0.612	Hydrogen Bromide, Hbr	-0.968
Allene, C ₃ H ₄	-0.744	Hydrogen Chloride, HC1	-0.650
Ammonia, NH ₃	-0.479	Hydrogen Fluoride, HF	-0.253
Argon, A	-0.569	Hydrogen Iodide, HI	-1.403
Bromine, Br ₂	-0.83	Hydrogen Sulhide, H ₂ S	-0.751
1,2-Butadiene, C ₄ H ₆	-1.047	Krypton, Kr	-0.853
1,3-Butadiene, C ₄ H ₆	-0.944	Methane, CH ₄	-0.512
n-Butane, C ₄ H ₁₀	-1.481	Neon, Ne	-0.205
iso-Butane, C ₄ H ₁₀	-1.485	Nitric Oxide, NO	+44.2
Butene-1, C ₄ H ₈	-1.205	Nitrogen, N ₂	-0.358
cis Butene-2, C ₄ H ₈	-1.201	Nitrogen Dioxide, NO ₂	+28.7
iso-Butene, C ₄ H ₈	-1.274	Nitrous Oxide, N ₂ O	-0.560
trans Butene-2, C ₄ H ₈	-1.274	n-Octane, C ₈ H ₁₈	-2.840
Carbon Dioxide, CO ₂	-0.623	Oxygen, O ₂	+100.0
Carbon Monoxide, CO	-0.354	n-Pentane, C ₅ H ₁₂	-1.810
Ethane, C ₂ H ₆	-0.789	iso-Pentane, C ₅ H ₁₂	-1.853
Ethylene, C ₂ H ₄	-0.553	neo-Pentane, C ₅ H ₁₂	-1.853
Helium, He	-0.059	Propane, C ₃ H ₈	-1.135
n-Heptane, C ₇ H ₁₆	-2.508	Propylene, C ₃ H ₆	-0.903
n-Hexane, C ₆ H ₁₄	-2.175	Water, H ₂ O	-0.381
cyclo-Hexane, C ₆ H ₁₂	-1.915	Xenon, Xe	-0.340
Hydrogen, H ₂	0.447		

TABLE 3-3. OXYGEN EQUIVALENTS OF COMMON GASES

3.10 BAROMETRIC PRESSURE COMPENSATION

Although normally calibrated for readout in percent oxygen, the PMD Analyzer Module actually responds to oxygen partial pressure. The partial pressure of the oxygen component in a gas mixture is proportional to the total pressure of the mixture. Thus readout is affected by pressure variations.

For instance, assume that an instrument is calibrated for correct readout with a standard gas containing 5% oxygen, admitted at the normal sea level atmospheric pressure of 14.7 psia (1013 hPa). If the operating pressure now drops to one-half of the original value (i.e., to 7.35 psia/506 hPa and the calibration controls are left at the previously established settings, the display reading for the standard gas will drop to 2.5%.

It is therefore necessary to calibrate the instrument at the same pressure that will be used during subsequent operation, and to maintain this pressure during operation.

Alternatively, an optional Barometric Pressure Compensation Board, typically used for suppressed range applications, can perform signal corrections automatically.

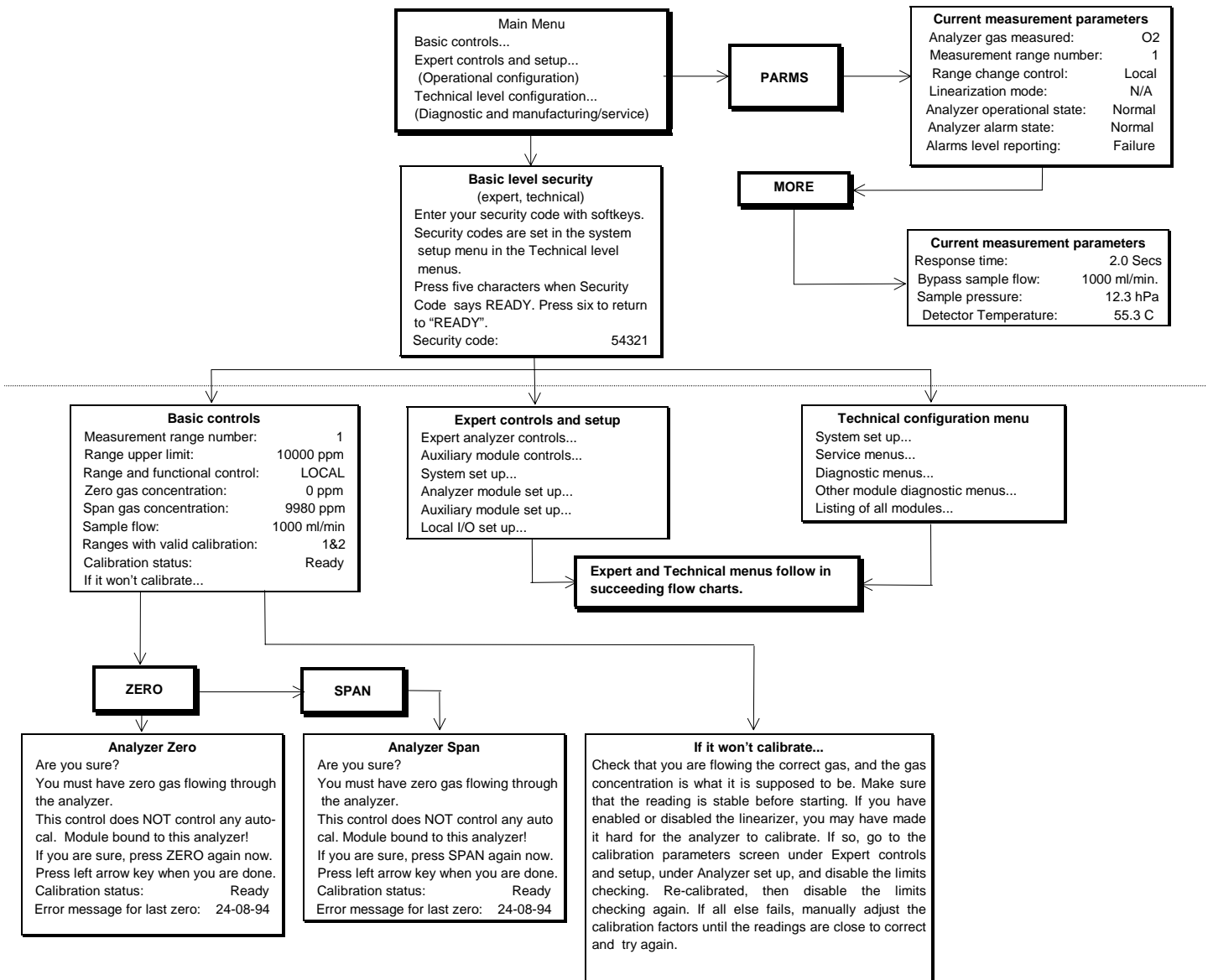

FIGURE 3-7. DISPLAY SCREENS (1 OF 5)

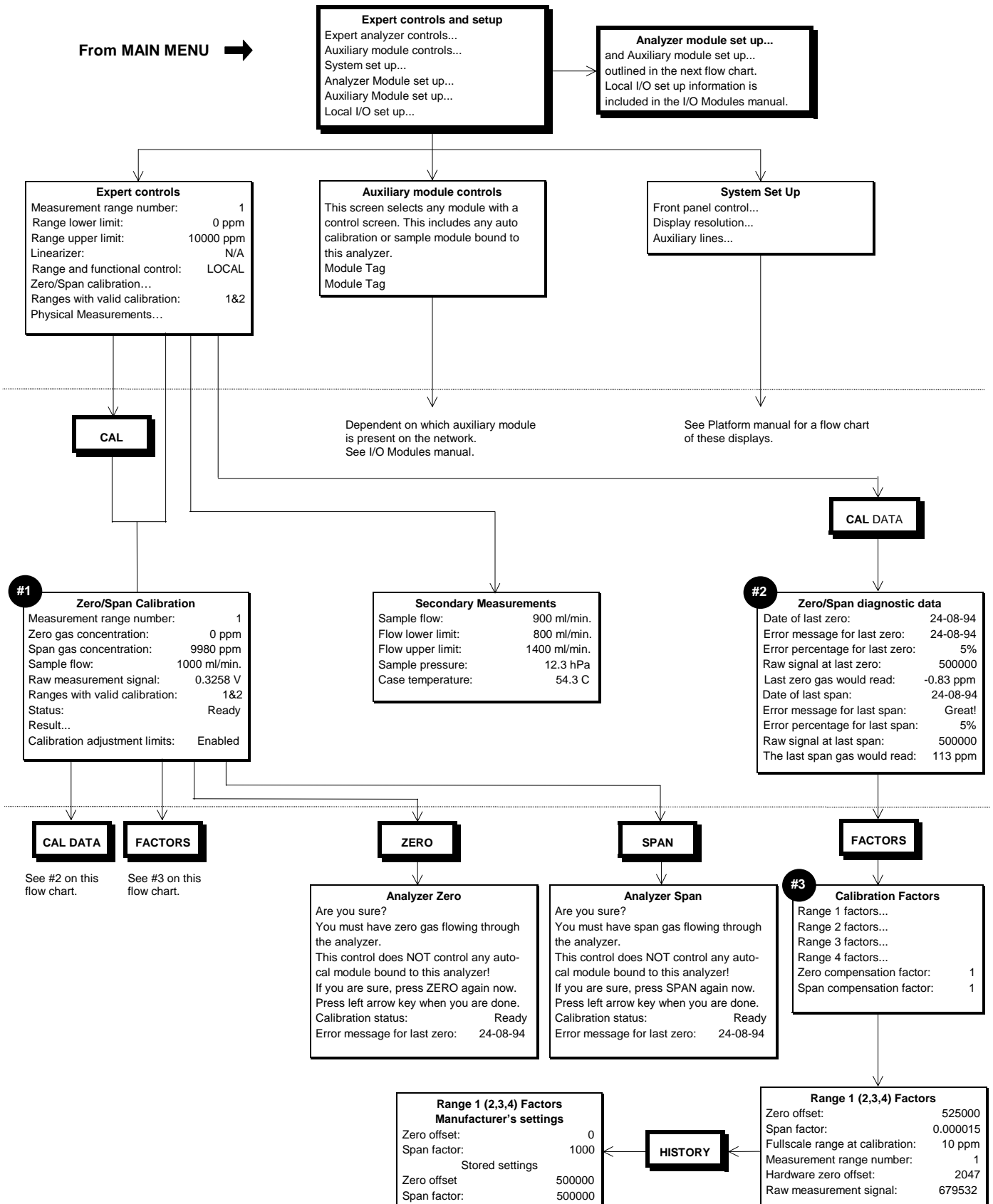

FIGURE 3-8. DISPLAY SCREENS (2 OF 5)

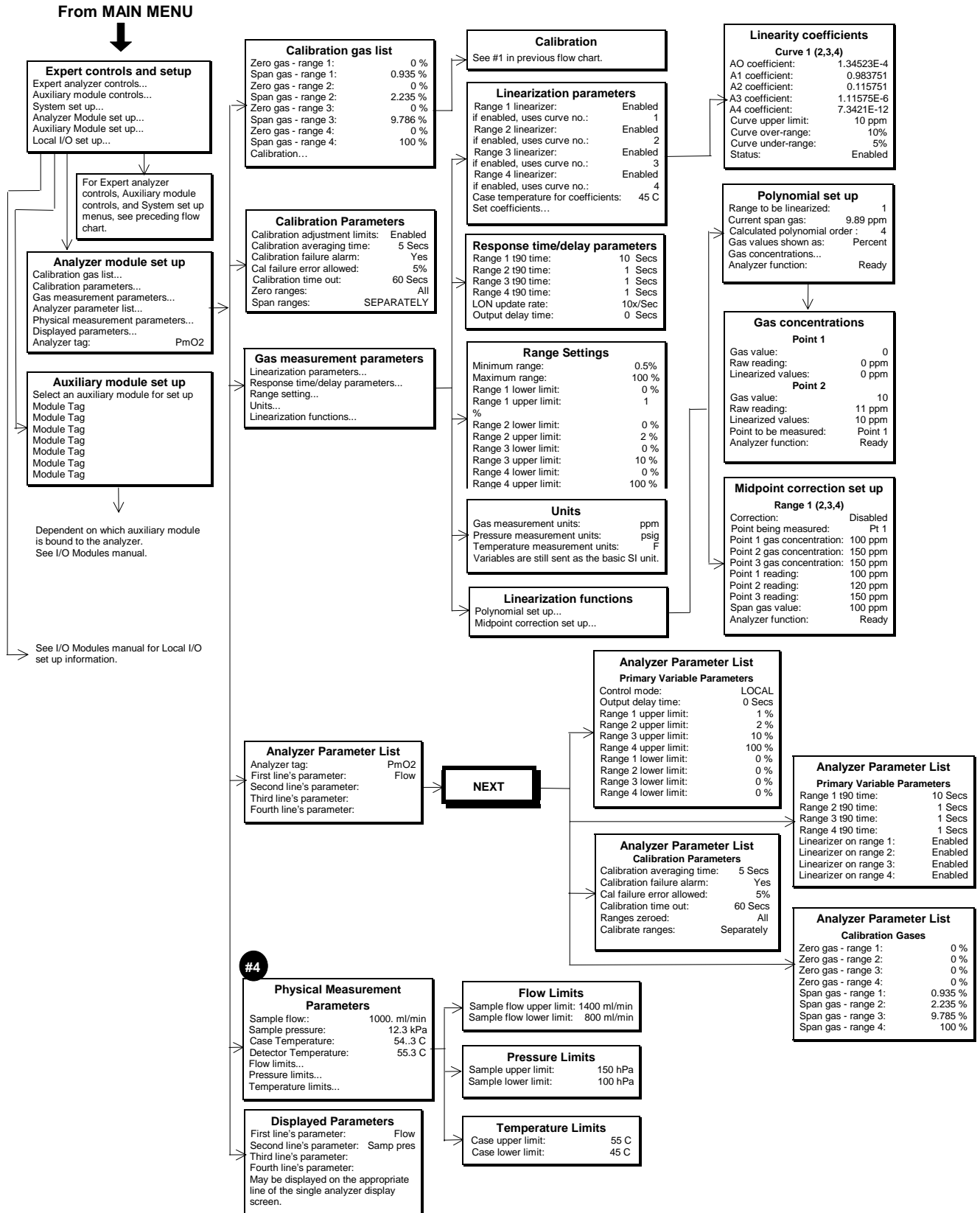

FIGURE 3-9. DISPLAY SCREENS (3 OF 5)

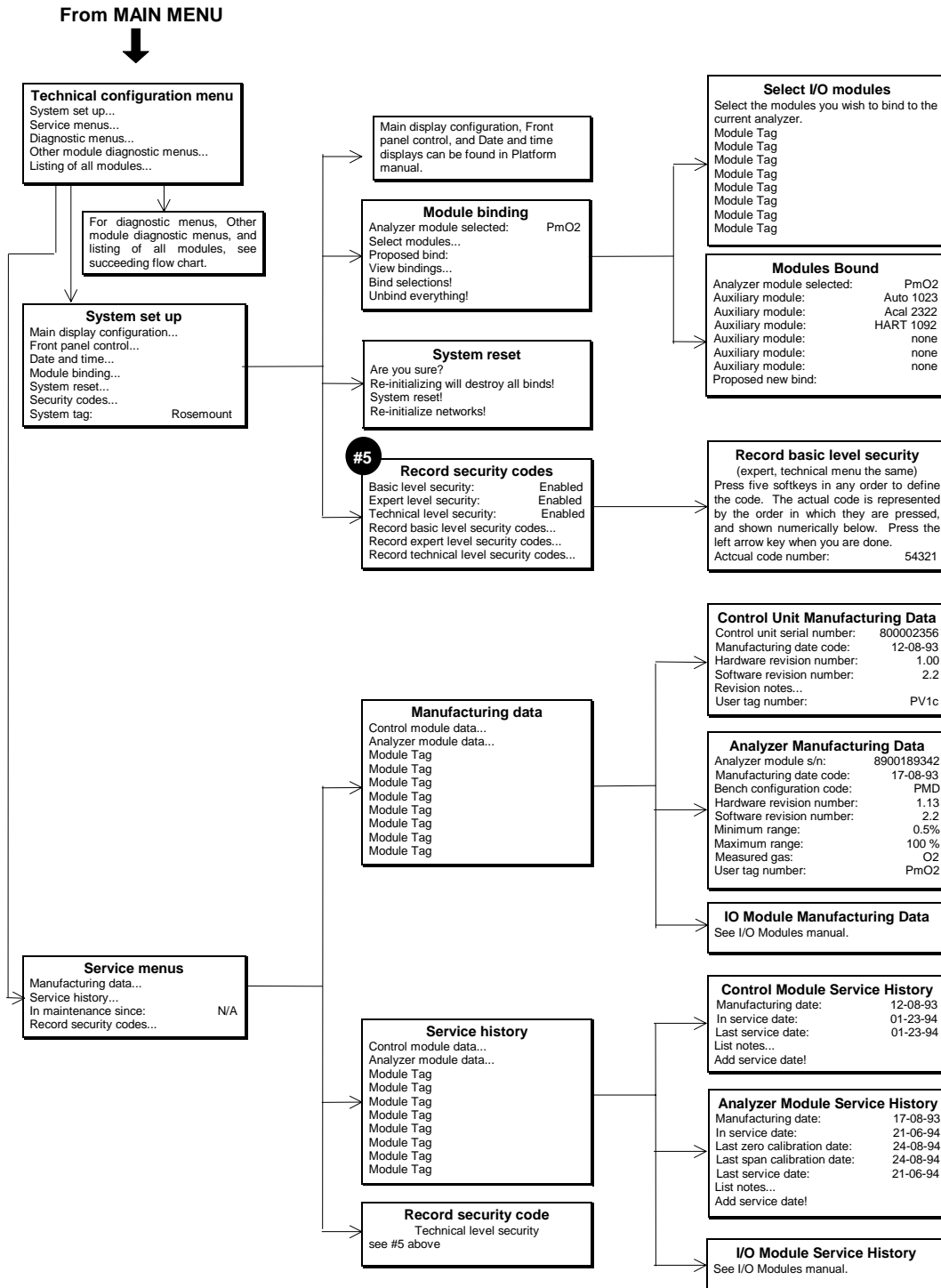

FIGURE 3-10. DISPLAY SCREENS (4 OF 5)

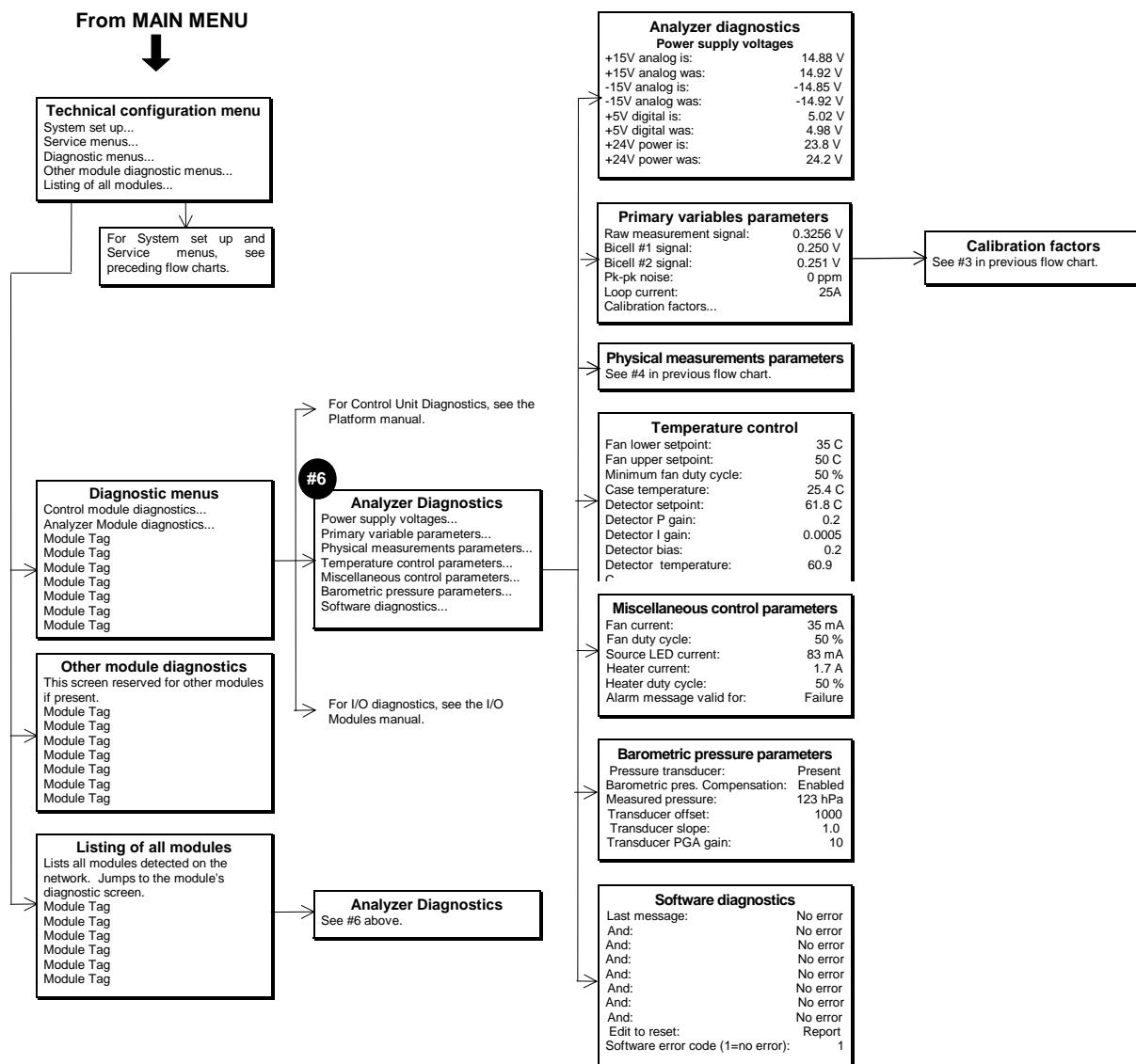

FIGURE 3-11. DISPLAY SCREENS (5 OF 5)

4 MAINTENANCE AND TROUBLESHOOTING



CAUTION: QUALIFIED PERSONNEL

This equipment should not be adjusted or repaired by anyone except properly qualified service personnel.

4.1 OVERVIEW

PMD Analyzer components that may require replacement include:

- All printed circuit board
- Thermal fuse inside Detector
- Case temperature sensor
- Flow sensor
- Power fuse
- Detector
- Module fan

The LED bi-cell assembly source required adjustment (rotation) anytime the Detector is disassembled. Refer to Figures 4-2 for locations of these components.

4.2 PRINTED CIRCUIT BOARD REPLACEMENT

Refer to Figure 4-1 for locations of the Signal, Microprocessor, Power Supply and (optional) Pressure Compensation Boards.

All boards are secured to a side of the analyzer module that folds out while interconnection wiring is still in place. Remove the securing screws and fold out the entire panel.

To remove individual boards on the fold-out panel, label and unplug all interconnection wiring, and remove securing hardware. Reverse this procedure for installation.

4.3 MODULE FAN REPLACEMENT

The Analyzer Module fan assembly is disassembled as shown in Figure 4-2.

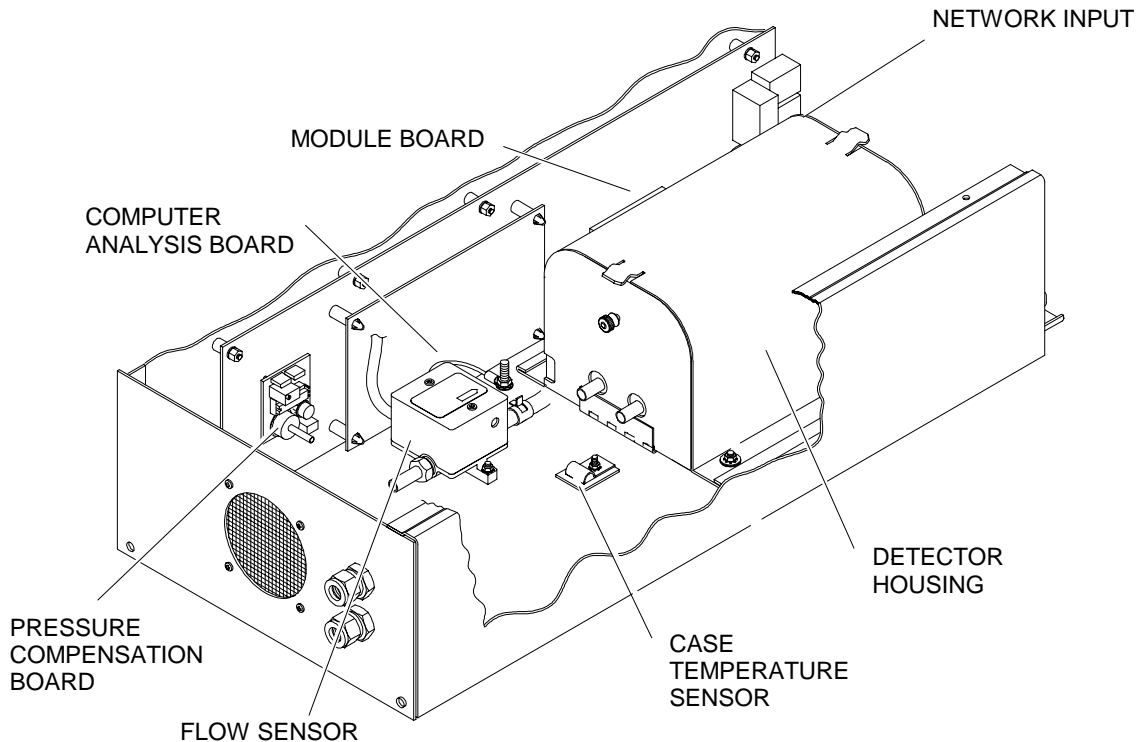

FIGURE 4-1. PMD MODULE - MAJOR COMPONENTS

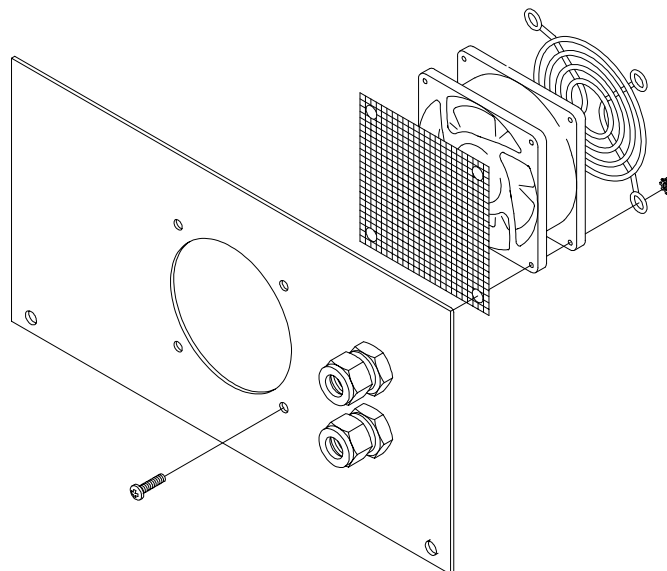

FIGURE 4-2. MODULE FAN ASSEMBLY

4.4 THERMAL FUSE REPLACEMENT

See Figure 4-3 for location of the Detector Thermal Fuse. Remove the Detector Assembly from the detector housing, replace the thermal Fuse. Reassemble in reverse order.

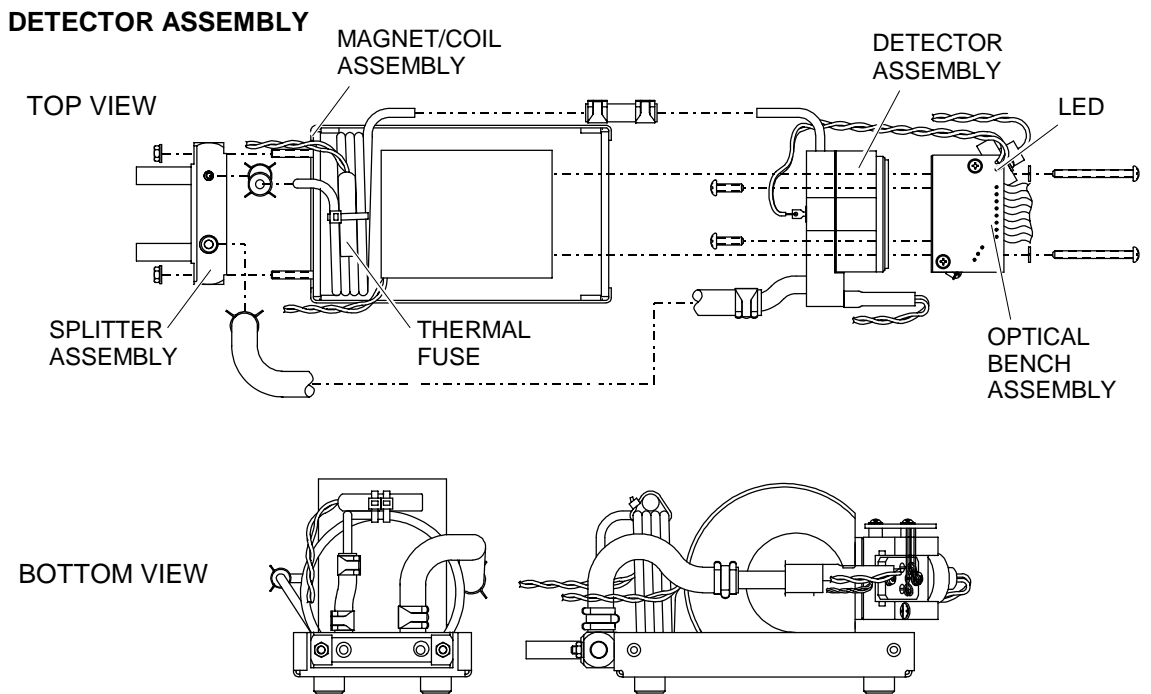
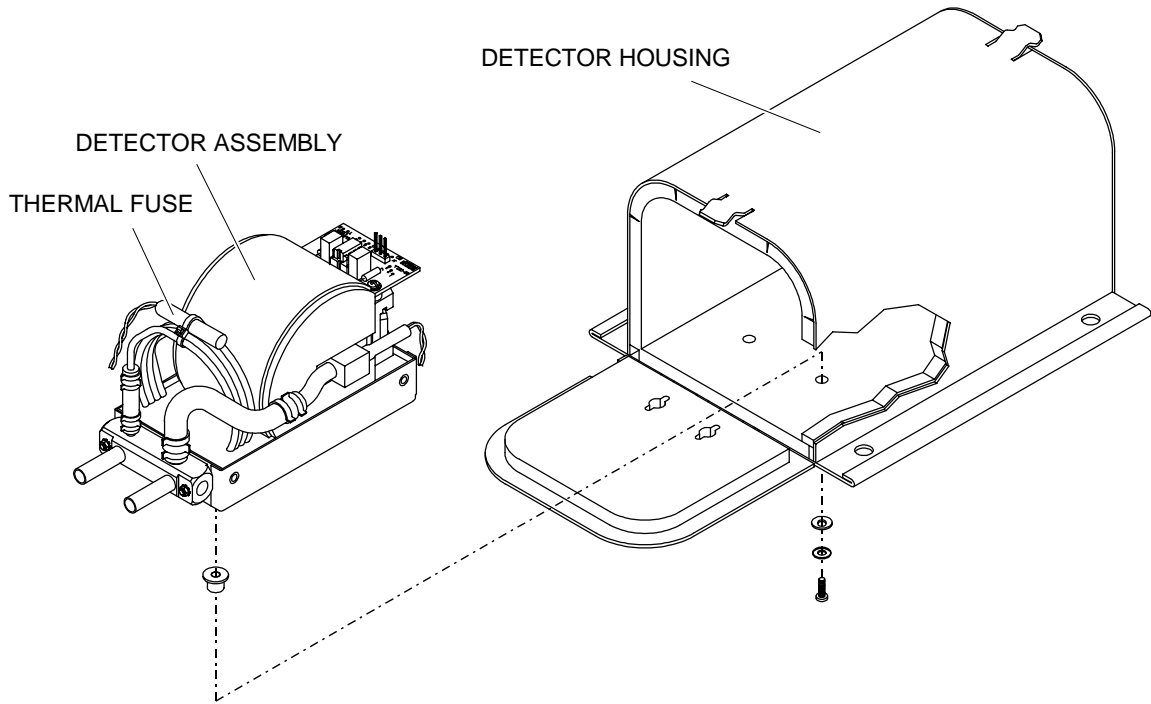

FIGURE 4-3. DETECTOR ASSEMBLY

4.5 FLOW SENSOR REPLACEMENT

See Figure 4-1 for location of Flow Sensor. To replace the sensor, remove connections to sample gas line and disconnect securing hardware. Reassemble in reverse order.

4.6 POWER FUSE REPLACEMENT

The power fuse is located in the Network Input Module and is accessible through the front panel of the PMD Analyzer. To remove the fuse, push and turn the fuseholder cap 1/4 turn counterclockwise. Verify that the replacement fuse is the same type and rating.

5 REPLACEMENT PARTS



WARNING: PARTS INTEGRITY

Tampering with or unauthorized substitution of components may adversely affect safety of this product. Use only factory-approved components for repair.

5.1 REPLACEMENT PARTS

902931	Sensor, Gas Flow
655856	Source/Holder Assembly
902922	Bi-Cell, Optical
655670	Pressure Compensation Board
903347	Fuse, Time-Delay 6A 250 VAC
657860	Module Board
622917	Sensor RTD
656576	Case Temperature Sensor
655893	Fan
898733	Detector Thermal Fuse
655838	Optical Bench Assembly
658083	Detector, Corrosion Resistant (Option)

NOTES

APPENDIX A. IDENTIFICATION MATRIX

Each analyzer is configured per the customer sales order. Below is the PMD sales matrix which lists the various configurations available.

To identify the configuration of an analyzer, locate the analyzer name-rating plate. The 12-position sales matrix identifier number appears on the analyzer name-rating plate.

P	NGA 2000 PARAMAGNETIC DETECTOR					
	Code	Language				
	A	English				
	X	Special				
		Code	Configuration Identifier			
		A10	Calibrated Standard Ranges: 0-5, 0-10, 0-25, 0-100%			
		A15	Calibrated Standard Ranges: 0-1, 0-5, 0-10, 0-25%			
		A20	Calibrated Standard Suppressed Ranges/Barometric Pressure Compensation: 90-100, 95-100, 98-100, 99-100%			
		A21	Same as A20 for elevations from 501 to 1500 ft above sea level			
		A22	Same as A20 for elevations from 1501 to 2500 ft above sea level			
		A23	Same as A20 for elevations from 2501 to 3500 ft above sea level			
		A24	Same as A20 for elevations from 3501 to 4500 ft above sea level			
		A25	Same as A20 for elevations from 4501 to 5500 ft above sea level			
		A26	Same as A20 for elevations from 5501 to 6500 ft above sea level			
		A27	Same as A20 for elevations from 6501 to 7500 ft above sea level			
		X99	Special Calibration Ranges			
			Code	Detector Type		
			A00	Rhodium Plated Current Loop		
			Z00	Titanium Current Loop (Standard)		
			ZZZ	No Selection		
			Z	No Selection		
P	A	A10	Z00	ZZZ	Z	Example

NOTES

GENERAL PRECAUTIONS FOR HANDLING AND STORING HIGH PRESSURE GAS CYLINDERS

*Edited from selected paragraphs of the Compressed
Gas Association's "Handbook of Compressed Gases"
published in 1981*

*Compressed Gas Association
1235 Jefferson Davis Highway
Arlington, Virginia 22202
Used by Permission*

1. Never drop cylinders or permit them to strike each other violently.
2. Cylinders may be stored in the open, but in such cases, should be protected against extremes of weather and, to prevent rusting, from the dampness of the ground. Cylinders should be stored in the shade when located in areas where extreme temperatures are prevalent.
3. The valve protection cap should be left on each cylinder until it has been secured against a wall or bench, or placed in a cylinder stand, and is ready to be used.
4. Avoid dragging, rolling, or sliding cylinders, even for a short distance; they should be moved by using a suitable hand-truck.
5. Never tamper with safety devices in valves or cylinders.
6. Do not store full and empty cylinders together. Serious suckback can occur when an empty cylinder is attached to a pressurized system.
7. No part of cylinder should be subjected to a temperature higher than 125°F (52°C). A flame should never be permitted to come in contact with any part of a compressed gas cylinder.
8. Do not place cylinders where they may become part of an electric circuit. When electric arc welding, precautions must be taken to prevent striking an arc against the cylinder.

(blank)

WARRANTY

Goods and part(s) (excluding consumables) manufactured by Seller are warranted to be free from defects in workmanship and material under normal use and service for a period of twelve (12) months from the date of shipment by Seller. Consumables, glass electrodes, membranes, liquid junctions, electrolyte, o-rings, etc., are warranted to be free from defects in workmanship and material under normal use and service for a period of ninety (90) days from date of shipment by Seller. Goods, part(s) and consumables proven by Seller to be defective in workmanship and/or material shall be replaced or repaired, free of charge, F.O.B. Seller's factory provided that the goods, part(s) or consumables are returned to Seller's designated factory, transportation charges prepaid, within the twelve (12) month period of warranty in the case of goods and part(s), and in the case of consumables, within the ninety (90) day period of warranty. This warranty shall be in effect for replacement or repaired goods, part(s) and the remaining portion of the ninety (90) day warranty in the case of consumables. A defect in goods, part(s) and consumables of the commercial unit shall not operate to condemn such commercial unit when such goods, part(s) and consumables are capable of being renewed, repaired or replaced.

The Seller shall not be liable to the Buyer, or to any other person, for the loss or damage directly or indirectly, arising from the use of the equipment or goods, from breach of any warranty, or from any other cause. All other warranties, expressed or implied are hereby excluded.

IN CONSIDERATION OF THE HEREIN STATED PURCHASE PRICE OF THE GOODS, SELLER GRANTS ONLY THE ABOVE STATED EXPRESS WARRANTY. NO OTHER WARRANTIES ARE GRANTED INCLUDING, BUT NOT LIMITED TO, EXPRESS AND IMPLIED WARRANTIES OR MERCHANTABILITY AND FITNESS FOR A PARTICULAR PURPOSE.

Limitations of Remedy. SELLER SHALL NOT BE LIABLE FOR DAMAGES CAUSED BY DELAY IN PERFORMANCE. THE SOLE AND EXCLUSIVE REMEDY FOR BREACH OF WARRANTY SHALL BE LIMITED TO REPAIR OR REPLACEMENT UNDER THE STANDARD WARRANTY CLAUSE. IN NO CASE, REGARDLESS OF THE FORM OF THE CAUSE OF ACTION, SHALL SELLER'S LIABILITY EXCEED THE PRICE TO BUYER OF THE SPECIFIC GOODS MANUFACTURED BY SELLER GIVING RISE TO THE CAUSE OF ACTION. BUYER AGREES THAT IN NO EVENT SHALL SELLER'S LIABILITY EXTEND TO INCLUDE INCIDENTAL OR CONSEQUENTIAL DAMAGES. CONSEQUENTIAL DAMAGES SHALL INCLUDE, BUT ARE NOT LIMITED TO, LOSS OF ANTICIPATED PROFITS, LOSS OF USE, LOSS OF REVENUE, COST OF CAPITAL AND DAMAGE OR LOSS OF OTHER PROPERTY OR EQUIPMENT. IN NO EVENT SHALL SELLER BE OBLIGATED TO INDEMNIFY BUYER IN ANY MANNER NOR SHALL SELLER BE LIABLE FOR PROPERTY DAMAGE AND/OR THIRD PARTY CLAIMS COVERED BY UMBRELLA INSURANCE AND/OR INDEMNITY COVERAGE PROVIDED TO BUYER, ITS ASSIGNS, AND EACH SUCCESSOR INTEREST TO THE GOODS PROVIDED HEREUNDER.

Force Majeure. Seller shall not be liable for failure to perform due to labor strikes or acts beyond Seller's direct control.

Rosemount Analytical

Rosemount Analytical Inc.

4125 EAST LA PALMA AVENUE • ANAHEIM, CALIFORNIA 92807-1802 • 714-986-7600 • FAX 714-577-8006
FEBRUARY 1997 • 7485189-C • PRINTED IN USA

(blank)

FIELD SERVICE AND REPAIR FACILITIES

Field service and repair facilities are located worldwide.

U.S.A.

To obtain field service on-site or assistance with a service problem, contact (24 hours, 7 days a week):

**National Response Center
1-800-654-7768**

INTERNATIONAL

Contact your local Rosemount Sales and Service office for service support.

FACTORY

For order administration, replacement Parts, application assistance, on-site or factory repair, service or maintenance contract information, contact:

**Rosemount Analytical Inc.
Process Analytical Division
Customer Service Center
1-800-433-6076**

RETURNING PARTS TO THE FACTORY

Before returning parts, contact the Customer Service Center and request a Returned Materials Authorization (RMA) number. Please have the following information when you call: *Model Number, Serial Number, and Purchase Order Number or Sales Order Number.*

Prior authorization by the factory must be obtained before returned materials will be accepted. Unauthorized returns will be returned to the sender, freight collect.

When returning any product or component that has been exposed to a toxic, corrosive or other hazardous material or used in such a hazardous environment, the user must attach an appropriate Material Safety Data Sheet (M.S.D.S.) or a written certification that the material has been decontaminated, disinfected and/or detoxified.

Return to:

**Rosemount Analytical Inc.
4125 East La Palma Avenue
Anaheim, California 92807-1802**

(blank)