

ISSUE	MODIF. ORDER NO.	WEEK	ISSUE	MODIF. ORDER NO.	WEEK	ISSUE	MODIF. ORDER NO.	WEEK
01	SME-6830	1050	02	SME-7436	1237			

1. Summary

The still pipe used with Rosemount 5900 LPG/LNG antenna is not supplied by RTR, but is to be manufactured by the customer according to the RTR drawing D9240041-910 or D7000001-466. Additional information is given in this instruction.

2. Function

The still pipe guides the radar waves to ensure a safe measurement undisturbed by structures in the tank and by the possible boiling of the liquid gas. The still pipe is perforated with holes in one vertical line to equalize the liquid level on the inside and outside of the pipe. One additional hole oriented 90 degrees from the line of equalization holes is used to locate a verification pin which provides a possibility to verify a known distance while the tank is under pressure. Due to the function it is important that the still pipe is manufactured according to one of the two drawings stated below with respect to holes, diameter, orientation etc.

3. Still pipe design

For still-pipe attached to the pipe flange, see installation drawing D7000001-910 and D9240040-983. For still-pipe attached to the bottom, see installation drawing D7000001-466 and D7000001-950. Pipe attached to the flange is to be preferred.

Use a stainless steel pipe with a wall thickness of 2-3 mm and inside diameter of 100 mm or a 4" Sch 10-40 stainless steel pipe. The pipe size must be specified when ordering the Rosemount 5900, since the antenna size is affected (i.e. different transition cones).

The equalization holes can have a diameter of 20 mm or 3/4" and are located in one single row. One additional hole which is oriented 90 degrees from the line of equalization holes is used to locate a verification pin. This hole should also have a diameter of 20 mm or 3/4". The position of the hole can be found on drawing D7000001-466 or D9240041-910.

The orientation of the verification pin hole must be in the same direction, within 5° as one of the bolt holes in the customer flange pressure vessel, see figure 4. The centre of the chosen bolt hole should be marked, since the position of verification pin must be possible to verify from the top of the still pipe. Mark the upper end of the pipe as well. This marking is later used for aligning with the 4 mm marking hole on the closing of the 5900 LPG/LNG antenna.

The joints of the still pipe should be made with an outer sleeve to avoid burrs or irregularities which can cause disturbances on the measuring performance. Max 1 mm gap between pipe ends is allowed due to the cause of disturbances.

The still pipe should be vertical within 0,5° (see figure 1 and 2). If the 4" pipe is installed into a 6" pipe, then it must fit through the top flange opening.

ISSUED BY EMe-PS	WEEK 1047	DOC. TYPE 2	PRODUCT CODE 5900	TITLE 5900 with LPG/LNG antenna Still pipe requirements				
APPROVED BY TT-TK	WEEK 1050	FILE MSWord		DOC NO. D9240041-915	ISSUE 02	PAGE 1/6		
				<small>The copyright/ownership of this document is and will remain ours. The document must not be used without our authorization or brought to the knowledge of a third party. Contravention will be prosecuted. Rosemount Tank Radar AB</small>				

ISSUE	MODIF. ORDER NO.	WEEK	ISSUE	MODIF. ORDER NO.	WEEK	ISSUE	MODIF. ORDER NO.	WEEK
01	SME-6830	1050	02	SME-7436	1237			

Figure 1. Still-pipe attached to the vessel flange

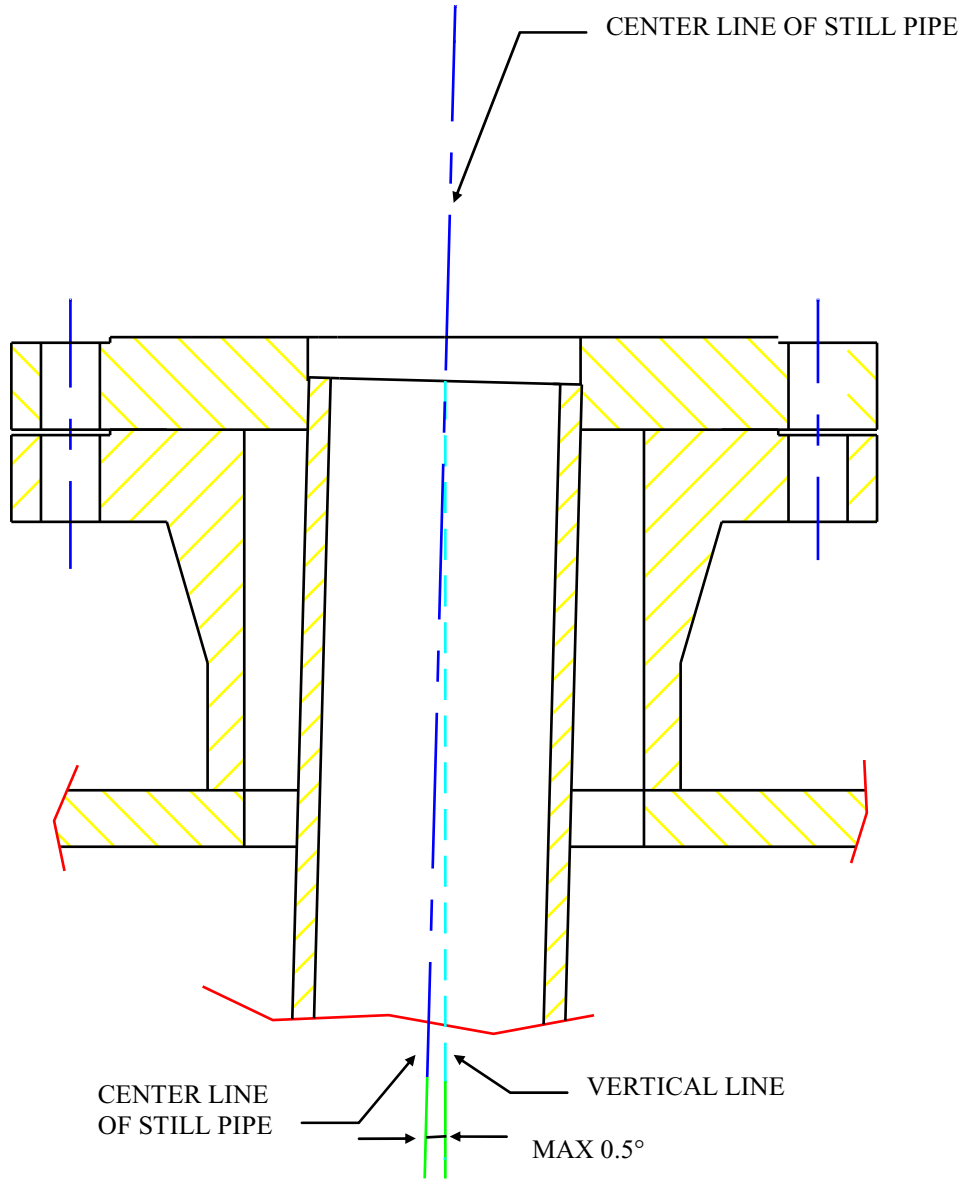

Alignment requirements for still pipe and vessel flange, pipe hung at vessel flange.

ISSUE	MODIF. ORDER NO.	WEEK	ISSUE	MODIF. ORDER NO.	WEEK	ISSUE	MODIF. ORDER NO.	WEEK
01	SME-6830	1050	02	SME-7436	1237			

Figure 2. Still-pipe attached to the vessel bottom.

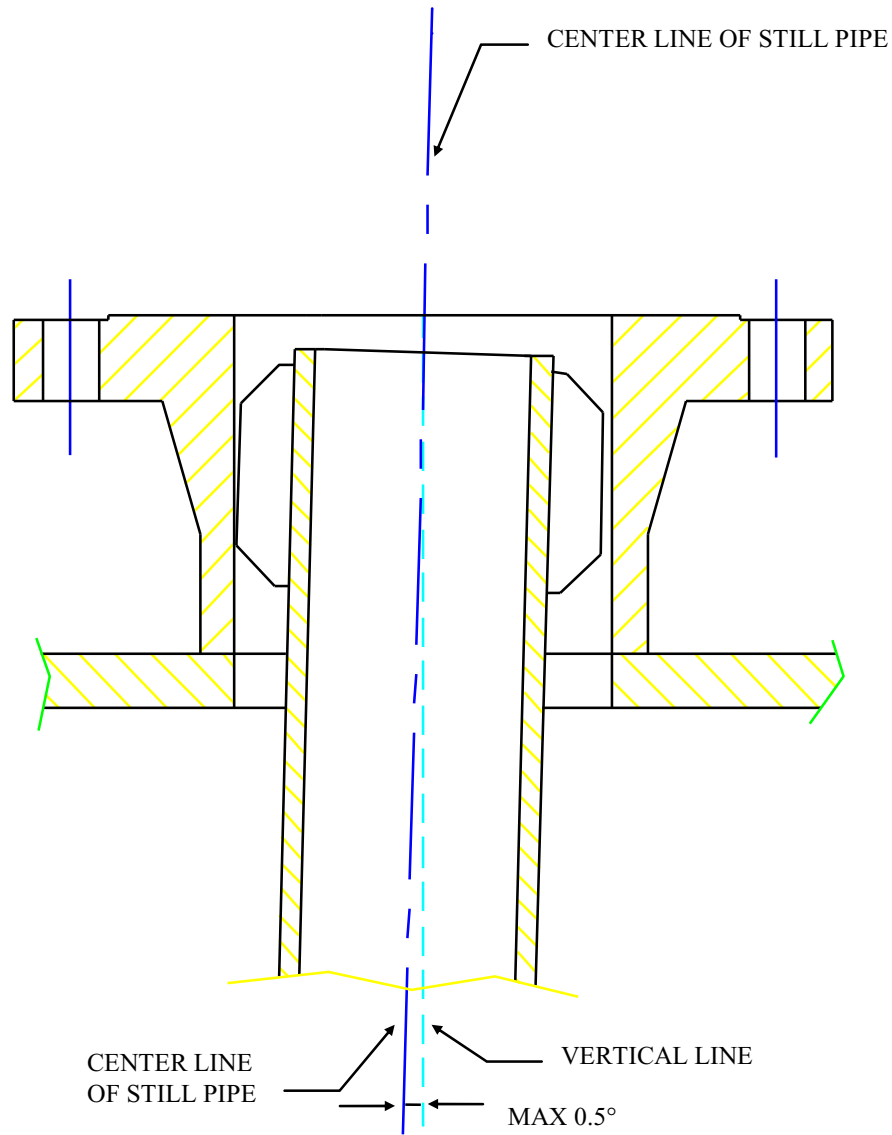

Alignment requirements for still pipe and vessel flange, pipe attached to vessel bottom.

ISSUE	MODIF. ORDER NO.	WEEK	ISSUE	MODIF. ORDER NO.	WEEK	ISSUE	MODIF. ORDER NO.	WEEK
01	SME-6830	1050	02	SME-7436	1237			

Mounting the verification pin

Rosemount delivers a *Reflector kit* and a *Verification pin kit* with each Radar Tank Gauge. These kits must be mounted on before installing the still pipe. The reflector is to be mounted at the end of the pipe (see Section 4). The verification pin consists of a small plate with a pin. The pin is mounted through the verification pin hole in the still pipe and attached to it by a hose clamp (supplied by RTR but most stainless models will do) ensuring that the plate is well aligned by the pipe around the hole (see Figure 3 and 4).

Figure 3. Verification pin assembly

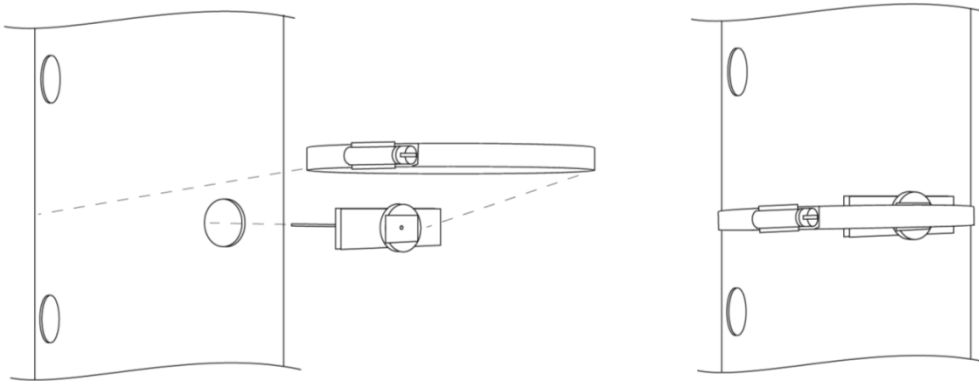
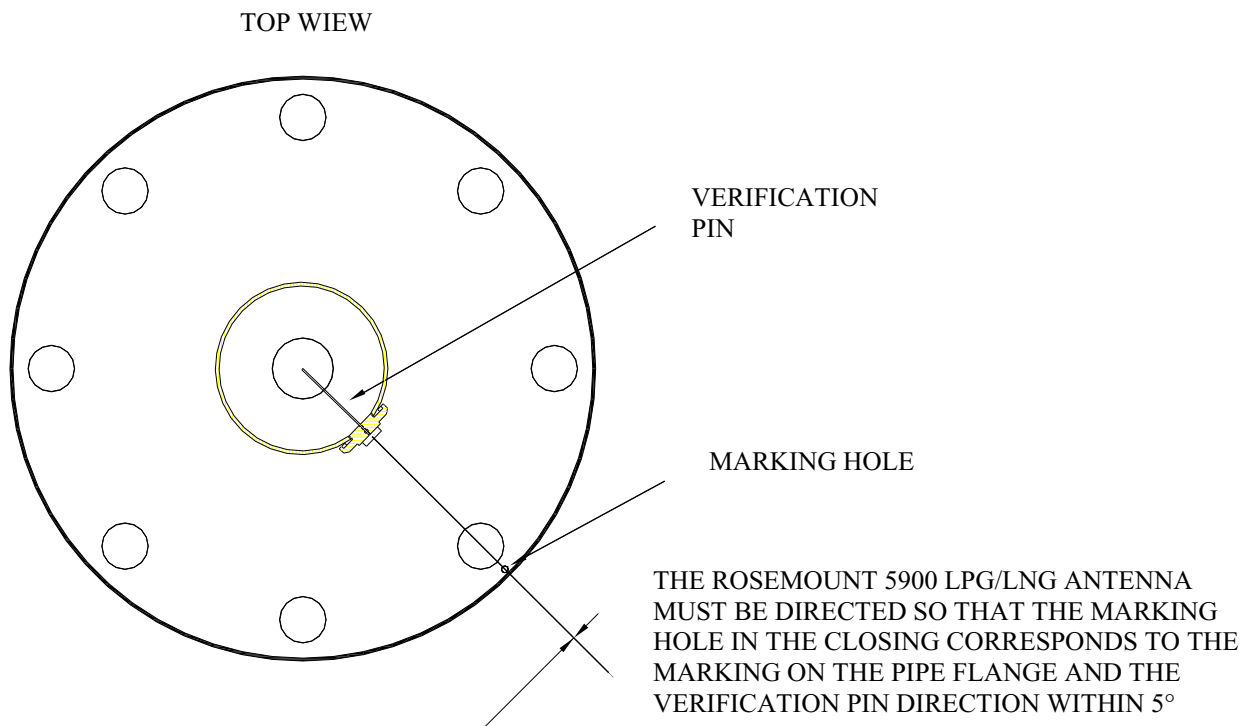

Figure 4. Alignment of the verification pin and marking hole.



ISSUE	MODIF. ORDER NO.	WEEK	ISSUE	MODIF. ORDER NO.	WEEK	ISSUE	MODIF. ORDER NO.	WEEK
01	SME-6830	1050	02	SME-7436	1237			

4. Mounting the reflector

The *Reflector kit* is mounted at the lower end of the still pipe in order to allow a small verification echo from the pipe end and to avoid echoes from the tank bottom.

The reflector kit shall be orientated in a way that the microwaves don't reflect back on any of the feet supporting the still-pipe. At least 45° angle between the reflection and the feet is recommended.

See installation dwg D92400041-910 and D7000001-466.

This instruction shows how to install the Reflector at the pipe end. It is a complement to the installation drawings D9240041-910 and D7000001-466.

The pipe could be:

- 4 inch, schedule 10 – 40 or
- DN 100 for metric pipes → Di=100 mm, t=2-3 mm

There are three different ways to assemble the reflector at the pipe end:

1. Welding at the top of the reflector (above the Ø4,1 holes). Note: Recommended.
2. Screw M4 + Nut (in the Ø4,1 hole). Note: Hole Ø4,1 have to be drilled in the pipe.
3. Rivet Ø4 (in the Ø4,1 hole). Note: Hole Ø4,1 have to be drilled in the pipe.

Figure 5. Mounting at Pipe – 4" schedule 10
Reflector part is mounted directly to the pipe.

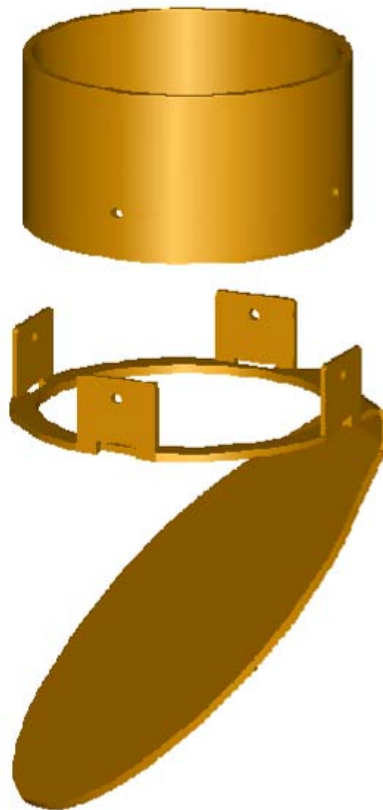

ISSUE	MODIF. ORDER NO.	WEEK	ISSUE	MODIF. ORDER NO.	WEEK	ISSUE	MODIF. ORDER NO.	WEEK
01	SME-6830	1050	02	SME-7436	1237			

Figure 6. Mounting at Pipe – 4” schedule 40
 Reflector is mounted to the pipe with the Ring marked 4” SCH 40.

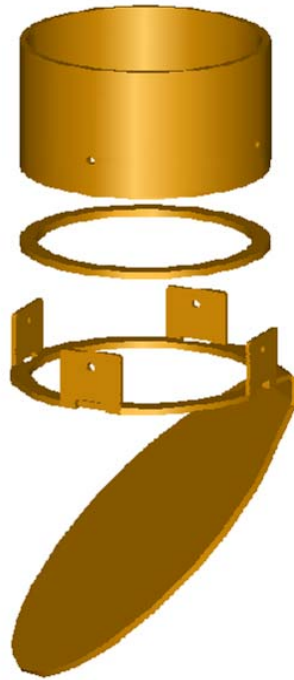

Figure 7. Mounting at Pipe – DN100:
 Reflector is mounted to the pipe with the Ring marked DN 100.

