

August 2016

Type P520L Reamer

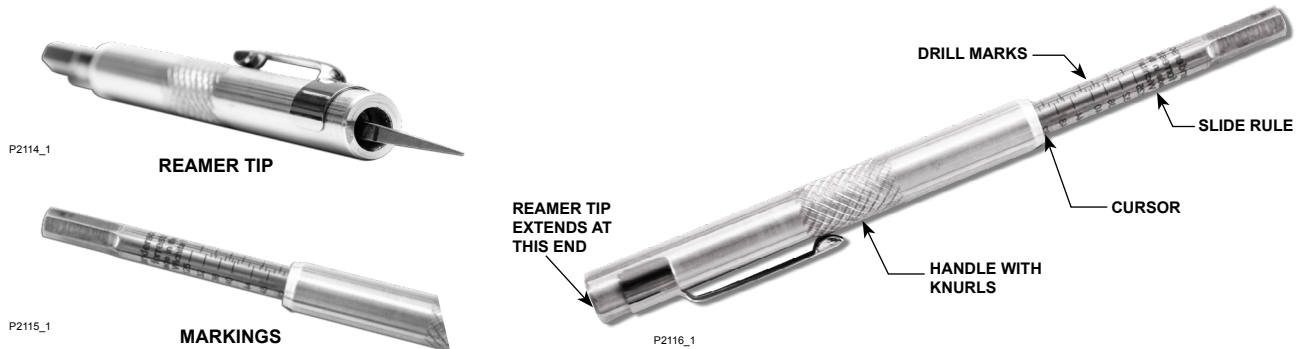

Figure 1. Type P520L Reamer

Introduction

The Type P520L tapered reamer is calibrated for propane vapor by drill size. Refer to the NATIONAL FUEL GAS CODE, NFPA 54-2006, Table F.1 (b) and Table F.1 (c) for BTU/hour for a specific orifice and gas size. Use Type P520L to enlarge or clean out orifices on LP-Gas appliances ranging from drill size no. 52 to 30 (0.0635 to 0.125 in.).

Use the reamer as follows:

The reamer is designed with knurls on the handle for better grip. Make sure reamer is held in vertical position while doing the following steps.

To enlarge orifices:

1. Loosen the reamer by twisting the knurls against the slide rule.
2. Push the slide rule towards the end of the reamer body until the cursor points to the desired orifice or drill size.
3. Once the cursor is aligned with the desired drill size, lock position by twisting the knurl in opposite directions.
4. Hold the orifice with one hand and the reamer with the other.
5. Insert the tip of the reamer into the orifice as far as it can go.
6. Start reaming until the orifice contacts the end of the reamer body.
7. Remove the reamer from the orifice.
8. Unlock the reamer and retract the slide rule to the fully closed position.
9. Lock handle.

To check orifice sizes:

1. Loosen the reamer.
2. Extend the reamer tip fully.
3. Lock the reamer.
4. Insert the reamer tip into the orifice until it sits quite snugly.
5. Unlock the reamer and allow the handle to drop and contact the tip of the orifice.
6. Lock position.
7. Read the indicated drill size
8. Remove the reamer and retract the slide rule to the fully closed position.
9. Lock handle.

CAUTION

Always retract the reamer to the fully closed position and tighten the handle before placing the reamer into pocket. Failure to do so may result in personal injury.

This reamer can also be used on appliance orifices where gas other than propane is used. The following chart shows the BTU Orifice Capacity by Gas and Orifice Sizes. (Tables are from NATIONAL FUEL GAS CODE, NFPA 54-2006, 2006 edition.)

Type P520L

Table F.1 (b). LP-Gases (BTU/hour at Sea Level)

ORIFICE OR DRILL SIZE	PROPANE	BUTANE
0.008	519	589
0.009	656	744
0.010	812	921
0.011	981	1112
0.012	1169	1326
80	1480	1678
79	1708	1936
78	2080	2358
77	2629	2980
76	3249	3684
75	3581	4059
74	4119	4669
73	4678	5303
72	5081	5760
71	5495	6230
70	6375	7227
69	6934	7860
68	7813	8858
67	8320	9433
66	8848	10,031
65	9955	11,286
64	10,535	11,943
63	11,125	12,612
62	11,735	13,304
61	12,367	14,020
60	13,008	14,747
59	13,660	15,486
58	14,333	16,249
57	15,026	17,035
56	17,572	19,921
55	21,939	24,872
54	24,630	27,922
53	28,769	32,615
52	32,805	37,190
51	36,531	41,414
50	39,842	45,168
49	43,361	49,157
48	46,983	53,263
47	50,088	56,783
46	53,296	60,420

Table F.1 (b). LP-Gases (BTU/hour at Sea Level) (continued)

ORIFICE OR DRILL SIZE	PROPANE	BUTANE
45	54,641	61,944
44	60,229	68,280
43	64,369	72,973
42	71,095	80,599
41	74,924	84,940
40	78,029	88,459
39	80,513	91,215
38	83,721	94,912
37	87,860	99,605
36	92,207	104,532
35	98,312	111,454
34	100,175	113,566
33	103,797	117,672
32	109,385	124,007
31	117,043	132,689
30	134,119	152,046
29	150,366	170,466

Notes:

	Propane	Butane
1. BTU per cubic foot	2516	3280
2. Specific gravity	1.52	2.01
3. Pressure at orifice, inches w.c.	11	11
4. Orifice coefficient	0.9	0.9

Table F.1 (c). Multipliers for Utility Gases of Another Specific Gravity

SPECIFIC GRAVITY	MULTIPLIER	SPECIFIC GRAVITY	MULTIPLIER
0.45	1.155	0.95	0.795
0.50	1.095	1.00	0.775
0.55	1.045	1.05	0.756
0.60	1.000	1.10	0.739
0.65	0.961	1.15	0.722
0.70	0.926	1.20	0.707
0.75	0.894	1.25	0.693
0.80	0.866	1.30	0.679
0.85	0.840	1.35	0.667
0.90	0.817	1.40	0.655

- continued -

✉ Webadmin.Regulators@emerson.com

Facebook.com/EmersonProcessManagement

🔍 Fisher.com

LinkedIn.com/company/emerson-process-management

Twitter.com/emersonprocess

**Emerson Process Management
Regulator Technologies**

Americas
McKinney, Texas 75070 USA
T +1 800 558 5853
+1 972 548 3574

Asia Pacific
Singapore 128461, Singapore
T +65 6770 8337

Europe
Bologna 40013, Italy
T +39 051 419 0611

Middle East and Africa
Dubai, United Arab Emirates
T +971 4 811 8100

D450013T012 © 1971, 2016 Emerson Process Management Regulator Technologies, Inc. All rights reserved. 07/16.

The Emerson logo is a trademark and service mark of Emerson Electric Co. All other marks are the property of their prospective owners. Fisher™ is a mark owned by Fisher Controls International LLC, a business of Emerson Process Management.

The contents of this publication are presented for information purposes only, and while effort has been made to ensure their accuracy, they are not to be construed as warranties or guarantees, express or implied, regarding the products or services described herein or their use or applicability. All sales are governed by our terms and conditions, which are available on request. We reserve the right to modify or improve the designs or specifications of our products at any time without notice.

Emerson Process Management Regulator Technologies, Inc does not assume responsibility for the selection, use or maintenance of any product. Responsibility for proper selection, use and maintenance of any Emerson Process Management Regulator Technologies, Inc. product remains solely with the purchaser.

