

Fisher™ FIELDVUE™ DVC6200 Digital Valve Controller

The FIELDVUE DVC6200 digital valve controller is a HART® communicating instrument that converts a two-wire 4-20 mA control signal into a pneumatic output to an actuator. It can easily be retrofitted in place of existing analog positioners on most Fisher and non-Fisher pneumatic actuators.

Features

Reliability

- **Linkage-Less Non-Contact Position Feedback**— The high performance, linkage-less feedback system eliminates physical contact between the valve stem and the DVC6200. There are no wearing parts so cycle life is maximized.
- **Built to Survive**—The field proven DVC6200 instrument has fully encapsulated electronics that resist the effects of vibration, temperature, and corrosive atmospheres. A weather-tight wiring terminal box isolates field wiring connections from other areas of the instrument.

Performance

- **Accurate and Responsive**— The two-stage positioner design provides quick response to large step changes and precise control for small setpoint changes.

Ease of Use

- **Enhanced Safety**— The DVC6200 is a HART communicating device, so information can be accessed anywhere along the loop. This flexibility can reduce exposure to hazardous environments and make it easier to evaluate valves in hard to reach locations.
- **Faster Commissioning**— HART communications allows you to quickly commission loops with a variety of tools, either locally at the valve assembly or remotely.

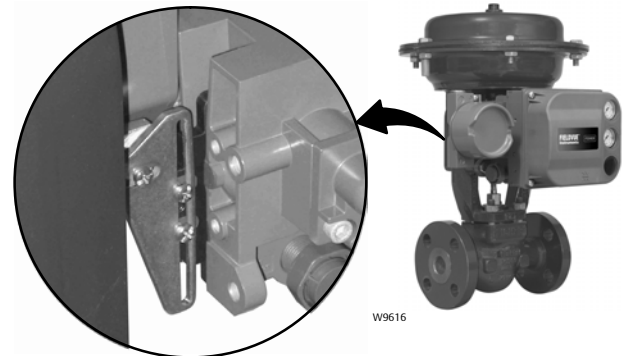

LINKAGE-LESS
FEEDBACK SYSTEM

- **Easy Maintenance**— The DVC6200 digital valve controller is modular in design. Critical working components can be replaced without removing field wiring or pneumatic tubing.

Value

- **Hardware Savings**— When installed in an integrated control system, significant hardware and installation cost savings can be achieved. Valve accessories such as limit switches and position transmitters can be eliminated because this information is available via the HART communication protocol.
- **Increased Uptime**— The self-diagnostic capability of the DVC6200 digital valve controller provides valve performance and health evaluation without shutting down the process or pulling the valve assembly from the line.
- **Improved Maintenance Decisions**— Digital communication provides easy access to the condition of the valve. Sound process and asset management decisions can be made by analysis of valve information through Fisher ValveLink™ software.

Figure 1. Alerts Status Screen

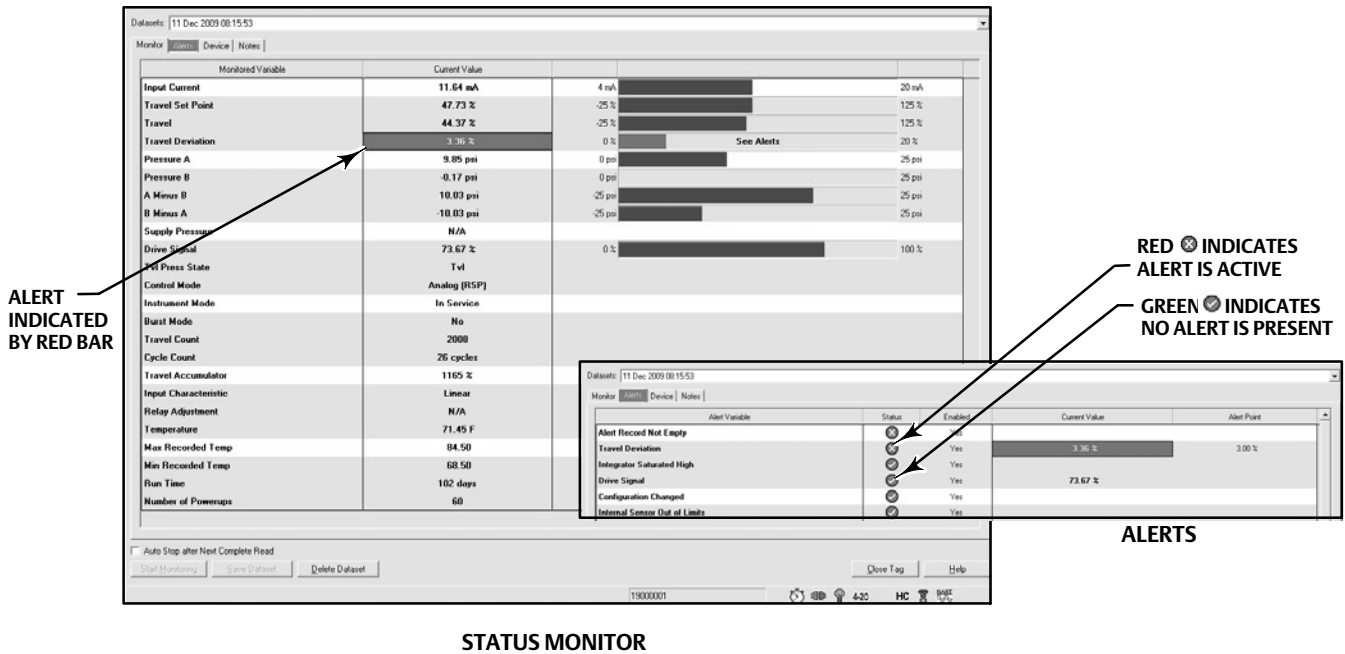

ALERT INDICATED BY RED BAR

RED ⊗ INDICATES ALERT IS ACTIVE

GREEN ⊙ INDICATES NO ALERT IS PRESENT

ALERTS

STATUS MONITOR

Valve Diagnostics

The DVC6200 digital valve controller provides a comprehensive library of valve diagnostic alerts, as shown in figure 1. These alerts are easily accessed with the 475 Field Communicator. When installed as part of a HART communicating system, the DVC6200 delivers prompt notification of current or potential equipment issues directly to the asset management system.

Alerts assist in identification and notification of the following situations:

- Valve travel deviation due to excessive valve friction or galling
- High cycle due to dither or improper tuning

- Total travel movement accumulation beyond a specified point resulting in packing wear
- Valve travel above or below a specified point
- Various instrument mechanical and electrical issues

These alerts are stored in memory on board the DVC6200.

For additional information on FIELDVUE diagnostics and ValveLink software refer to Fisher bulletin 62.1:ValveLink Software ([D102227X012](#)).

Specifications

Available Mounting

- Integral mounting to the Fisher GX Control Valve and Actuator System
- Integral mounting to Fisher rotary actuators
- Sliding-stem linear applications
- Quarter-turn rotary applications

DVC6200 digital valve controllers can also be mounted on other actuators that comply with IEC 60534-6-1, IEC 60534-6-2, VDI/VDE 3845 and NAMUR mounting standards.

Communication Protocol

- HART 5 or ■ HART 7

Input Signal

Point-to-Point

Analog Input Signal: 4-20 mA DC, nominal; split ranging available

Minimum Voltage Available at Instrument Terminals must be 9.5 VDC for analog control, 10 VDC for HART communication

Minimum Control Current: 4.0 mA

Minimum Current w/o Microprocessor Restart: 3.5 mA

Maximum Voltage: 30 VDC

Overcurrent protected

Reverse Polarity protected

Multi-drop

Instrument Power: 11 to 30 VDC at 10 mA

Reverse Polarity protected

Supply Pressure⁽¹⁾

Minimum Recommended: 0.3 bar (5 psig) higher than maximum actuator requirements

Maximum: 10.0 bar (145 psig) or maximum pressure rating of the actuator, whichever is lower

Supply Medium

Air or Natural Gas

Supply medium must be clean, dry, and noncorrosive and meet the requirements of ISA Standard 7.0.01 or ISO 8573-1

Output Signal

Pneumatic signal, up to full supply pressure

Minimum Span: 0.4 bar (6 psig)

Maximum Span: 9.5 bar (140 psig)

Action: ■ Double, ■ Single Direct or ■ Reverse

Steady-State Air Consumption⁽²⁾⁽³⁾

At 1.4 bar (20 psig) supply pressure: Less than 0.38 normal m³/hr (14 scfh)

At 5.5 bar (80 psig) supply pressure: Less than 1.3 normal m³/hr (49 scfh)

Maximum Output Capacity⁽²⁾⁽³⁾

At 1.4 bar (20 psig) supply pressure:

10.0 normal m³/hr (375 scfh)

At 5.5 bar (80 psig) supply pressure:

29.5 normal m³/hr (1100 scfh)

Operating Ambient Temperature Limits⁽¹⁾⁽⁴⁾

-40 to 85°C (-40 to 185°F)

-52 to 85°C (-62 to 185°F) for instruments utilizing the Extreme Temperature option (fluorosilicone elastomers)

Independent Linearity⁽⁵⁾

Typical Value: ±0.50% of output span

Electromagnetic Compatibility

Meets EN 61326-1:2013

Immunity—Industrial locations per Table 2 of the EN 61326-1 standard.

Emissions—Class A

ISM equipment rating: Group 1, Class A

Vibration Testing Method

Tested per ANSI/ISA-S75.13.01 Section 5.3.5.

Input Impedance

An equivalent impedance of 550 ohms may be used.

This value corresponds to 11V @ 20 mA.

Humidity Testing Method

Tested per IEC 61514-2

Electrical Classification

Hazardous Area Approvals

CSA— Intrinsicly Safe, Explosion-proof, Division 2, Dust Ignition-proof

FM— Intrinsicly Safe, Explosion-proof, Non-Incendive, Dust Ignition-proof

ATEX— Intrinsicly Safe, Flameproof, Type n

IECEx— Intrinsicly Safe, Flameproof, Type n

Electrical Housing

CSA— Type 4X, IP66 ATEX— IP66

FM— Type 4X, IP66 IECEx— IP66

-continued-

Specifications (continued)

Other Classifications/Certifications

Natural Gas Certified, Single Seal Device— CSA, FM, ATEX, and IECEx

Lloyds Register— Marine Type Approval

CUTR— Customs Union Technical Regulations (Russia, Kazakhstan, Belarus, and Armenia)

INMETRO— National Institute of Metrology, Quality and Technology (Brazil)

KGS— Korea Gas Safety Corporation (South Korea)

NEPSI— National Supervision and Inspection Centre for Explosion Protection and Safety of Instrumentation (China)

PESO CCOE— Petroleum and Explosives Safety Organisation - Chief Controller of Explosives (India)

TIIS— Technology Institution of Industrial Safety (Japan)

Not all certifications apply to all constructions. Contact your [Emerson sales office](#) or Local Business Partner for classification/certification specific information.

Connections

Supply Pressure: 1/4 NPT internal and integral pad for mounting 67CFR regulator

Output Pressure: 1/4 NPT internal

Tubing: 3/8-inch recommended

Vent: 3/8 NPT internal

Electrical: 1/2 NPT internal or M20⁽⁶⁾

Actuator Compatibility

Stem Travel (Sliding-Stem Linear)

Minimum: 6.35 mm (0.25 inch)

Maximum: 606 mm (23-7/8 inches)

Shaft Rotation (Quarter-Turn Rotary)

Minimum: 45°

Maximum: 90°

Weight

Aluminum: 3.5 kg (7.7 lbs)

Stainless Steel: 8.6 kg (19 lbs)

Construction Materials

Housing, module base and terminal box:

A03600 low copper aluminum alloy (standard),

Stainless Steel (optional)

Cover: Thermoplastic polyester

Elastomers: Nitrile (standard)

Options

- Supply and output pressure gauges or ■ Tire valves
- Integral mounted filter regulator ■ Low-Bleed Relay
- Extreme Temperature ■ Natural Gas Certified, Single Seal Device ■ Remote Mount⁽⁷⁾ ■ Stainless Steel
- Integral 4-20mA Position Transmitter⁽⁸⁾⁽⁹⁾
- Integral Limit Switch⁽¹⁰⁾

Additional Information

For additional information go to [Fisher.com](#) or contact your Emerson sales office or Local Business Partner.

NOTE: Specialized instrument terms are defined in ANSI/ISA Standard 51.1 - Process Instrument Terminology.

1. The pressure/temperature limits in this document and any other applicable code or standard should not be exceeded.
2. Normal m³/hour - Normal cubic meters per hour at 0°C and 1.01325 bar, absolute. Scfh - Standard cubic feet per hour at 60°F and 14.7 psia.
3. Values at 1.4 bar (20 psig) based on a single-acting direct relay; values at 5.5 bar (80 psig) based on double-acting relay.
4. Temperature limits vary based on hazardous area approval.
5. Not applicable for travels less than 19 mm (0.75 inch) or for shaft rotation less than 60 degrees. Also not applicable for digital valve controllers in long-stroke applications.
6. M20 electrical connection only available with ATEX approvals.
7. 4-conductor shielded cable, 18 to 22 AWG minimum wire size, in rigid or flexible metal conduit, is required for connection between base unit and feedback unit.
8. 4-20 mA output, isolated; *Supply Voltage:* 8-30 VDC; *Reference Accuracy:* 1% of travel span.
9. Position transmitter meets the requirements of NAMUR NE43; selectable to show failure low (< 3.6 mA) or failure high (> 22.5 mA). Fail high available only when the positioner is powered.
10. One isolated switch, configurable throughout the calibrated travel range or actuated from a device alert; *Off State:* 0 mA (nominal); *On State:* up to 1 A; *Supply Voltage:* 30 VDC maximum; *Reference Accuracy:* 2% of travel span.

Neither Emerson, Emerson Automation Solutions, nor any of their affiliated entities assumes responsibility for the selection, use or maintenance of any product. Responsibility for proper selection, use, and maintenance of any product remains solely with the purchaser and end user.

Fisher, FIELDVUE, and ValveLink are marks owned by one of the companies in the Emerson Automation Solutions business unit of Emerson Electric Co. Emerson Automation Solutions, Emerson, and the Emerson logo are trademarks and service marks of Emerson Electric Co. HART is a registered trademark of FieldComm Group. All other marks are the property of their respective owners.

The contents of this publication are presented for informational purposes only, and while every effort has been made to ensure their accuracy, they are not to be construed as warranties or guarantees, express or implied, regarding the products or services described herein or their use or applicability. All sales are governed by our terms and conditions, which are available upon request. We reserve the right to modify or improve the designs or specifications of such products at any time without notice.

Emerson Automation Solutions
Marshalltown, Iowa 50158 USA
Sorocaba, 18087 Brazil
Cernay, 68700 France
Dubai, United Arab Emirates
Singapore 128461 Singapore

www.Fisher.com

