

# Fisher™ CVX Steam Conditioning Valve

The Fisher CVX Steam Conditioning Valve is designed to handle the moderate to severe applications in today's cycling power plants as well as provide precise pressure and temperature control for process applications. The CVX incorporates over 30 years of steam conditioning experience and product development. The valve body is designed with the latest finite element analysis (FEA) and computational fluid dynamics (CFD) tools to optimize performance and reliability for demanding steam systems.

The CVX valve design provides an exceptional combination of performance and maintainability. The simplified trim configuration is thermally compensated to handle rapid changes in temperatures, as expected during a turbine trip, without any sticking or binding.

Water atomization and vaporization are key elements in any steam conditioning application. The CVX design incorporates a spraywater manifold of variable geometry AF nozzles that produce an optimized spray pattern over a wide operating range. These nozzles are strategically placed to achieve optimal mixing and quick vaporization at all flowing conditions. Years of research in spray atomization and vaporization were key to optimizing the water injection system. Extensive use of CFD analysis, in addition to field performance feedback, was used to validate spray system enhancements.

## Features

- **Total Steam Control**-- Combines pressure and temperature control in a single valve.
- **Full Pressure Drop Capability**-- Rugged cage-guided design enables handling of full pressure drop of main steam.
- **High Temperature Capability with Available Class V Shutoff**-- Use of the Fisher Bore Seal trim gives capability of Class V shutoff up to 593°C (1100°F). This unique balanced trim is field-proven. See figure 2.
- **Forged Valve Body**-- FEA designed valve body can handle the most demanding applications without thermal stress problems.
- **Thermally Compensated Trim**-- The cage is nitrided for maximum life and is allowed to grow during thermally induced excursions. The plug is continuously guided and employs cobalt-based overlays for guide bands and tight metal-to-metal shutoff against the seat.
- **Easy Maintenance Seat Ring**-- Welded design provides Class V shutoff and long life. Deep Alloy 6 overlay can be refinished multiple times to maintain



tight shutoff. Optional bolted seat rings are also available.

- **Spiral-Wound Gaskets for Excellent Bonnet Sealing Under All Service Conditions**-- Premium gaskets provided with N07750 windings and graphite filler material.
- **Precise Spraywater Injection**-- CFD designed spray manifold determines water injection point and insertion depth to maximize mixing and quick vaporization.
- **High Turndown**-- Standard trim control rangeability is 50:1. Special construction can provide up to 75:1 turndown.
- **Quick Stroking Actuation**-- High performance pneumatic piston actuators with FIELDVUE™ digital valve controllers can achieve full stroke in less than 2 seconds while still maintaining highly accurate step response. Optimized digital valve controllers are available when high stroke speeds are required. Contact your [Emerson sales office](#) or Local Business Partner for assistance.
- **Performance Diagnostics**-- With the self-diagnostic capability, questions can be answered about a valve's performance, without pulling the valve from the line. The present valve/actuator signature (seat load, friction, etc.) can be compared against previously stored signatures to discover performance changes before they cause process control problems.
- **More compact body and trim profile**, creating a lighter valve that requires less support without compromising structural integrity

## Options

- **Startup Trim**-- Protects the working trim and machined surfaces of the valve body during steam blow.
- **Hydro-Plug**-- Provides a convenient way to establish hydrotest boundaries associated with using a split pressure class valve.
- **Split Functionality**-- When piping dictates, the CVX valve can be provided as separate components allowing the pressure control in the valve body and separate temperature reduction downstream in a steam cooler.
- **Commissioning Service**-- Proper installation of flushing trim and hydro-plug fixtures, along with reassembly and calibration of turbine bypass valves, is critical for the valves to be ready for service when needed. Let skilled Emerson Automation Solutions technicians take care of this vital commissioning service to protect this very important plant asset.
- **Diagnostic Services**-- The Emerson Automation Solutions Diagnostic Services Group delivers world class services and innovative technologies for top performance of critical service valves and other production assets.
- **Enhanced low noise diffuser technology**-- Helps eliminate noise generated by recirculated and expanded flow
- **Seat ring diffusers** -- incorporate bolted seat ring with diffuser technology for easy maintenance.

**Physical Specifications**

**End Connection Sizes<sup>(1)</sup>**

- Inlet: NPS 4 - 24
- Outlet: NPS 8 - 48

**End Connection Types**

- Butt weld (all sizes)
- Raised Face Flanges (all sizes)

**Configuration**

Angle Pattern (Flow Down)

**Valve Body Ratings<sup>(2)</sup>**

See table 1

**Maximum Pressure Drop<sup>(1)</sup>**

Valve bodies and trim capable of full ASME rated pressure drops

**Flow Characteristics<sup>(3)</sup>**

Linear

**Flow Direction**

Linear: Flow Down

**Port Diameter and Maximum Travel**

See table 1

**Bonnet Type**

Bolted

**Shutoff Classifications per ANSI/FCI 70-2 and IEC 60534-4**

- Class V (standard)
- Class IV (optional)

1. Standard end connection sizes.  
2. Not all valve sizes are available in all pressure ratings.  
3. Contact your [Emerson sales office](#) or Local Business Partner for special characterized cages.

**Table 1. Port Diameter and Maximum Travel Offerings for Fisher CVX Trim**

SEAT RING TYPE	INLET PRESSURE RATING	PORT DIAMETER		MAXIMUM TRAVEL		MAXIMUM CAPACITY <sup>(1)</sup>	
		mm	Inches	mm	Inches	C <sub>v</sub>	X <sub>t</sub>
Welded Seat	CL150 to CL2500	120	4.70	89	3.5	373	0.65
		159	6.25	102	4	544	0.65
		194	7.62	146	5.75	960	0.65
		234	9.20	178	7	1412	0.65
	CL150 to CL1500	285	11.20	203	8	2078	0.65
		349	13.75	267	10.5	3208	0.65
CL150 to CL900	424	16.70	318	12.5	4627	0.65	
Bolted Seat	CL150 to CL2500	87	3.44	70	2.75	200	0.65
		120	4.70	89	3.5	373	0.65
		159	6.25	102	4	544	0.65
		194	7.62	146	5.75	960	0.65
	CL150 to CL1500	234	9.20	178	7	1412	0.65
		285	11.20	203	8	2078	0.65
	CL150 to CL900	349	13.75	267	10.5	3208	0.65
		424	16.70	318	12.5	4627	0.65

1. Value shown is trim capacity only. Overall valve capacity will be affected by outlet diffuser sizing requirements.

**Material Specifications**

**Body/Bonnet**

- SA105 (Carbon Steel)
- SA182 Grade F22 (2.25Cr-1Mo)
- SA182 Grade F91 (9Cr-1Mo-V)

**Bonnet Bolting**

- SA105 Valve Body — SA193 Grade B7 up to 427°C (800°F)
- SA182 Grade F22 Valve Body — SA193 Grade B16 up to 524°C (975°F), N07718 above 524°C (975°F) to maximum of 566°C (1050°F)
- SA182 Grade F91 Valve Body — N07718 up to 593°C (1100°F)

**Control Plug**

- F22 with Alloy 6 guiding and seating surfaces<sup>(1)</sup>
- F91 with Alloy 6 guiding and seating surfaces<sup>(2)</sup>

**Stem**

- SA479 Type S20910 with SA 105 body
- All others use N07718 stems

**Cage**

- SA182 Grade F22 Nitrided<sup>(1)</sup>
- SA182 F91 Nitrided<sup>(2)</sup>

**Welded Seat (standard)**

- SA105 Valve Body -- Carbon Steel with Alloy 6 Seating Surface
- SA182 Grade F22 Valve Body -- F22 with Alloy 6 Seating Surface
- SA182 Grade F91 Valve Body -- F91 with Alloy 6 Seating Surface

**Bolted Seat (optional)**

- F22 with Alloy 6 seating surface up to 482°C (900°F)
- N06625 with Alloy 6 seating surface above 482°C (900°F)

**Piston Rings**

Alloy 6 with N07750 Expander

**Bore Seal**

N07718

**Gaskets**

N07750/Graphite

**Packing**

Graphite/Flexible Graphite

**Nozzles**

S41000 SST

1. For use with SA105 or F22 valve body.  
2. For use with F91 valve body.

Figure 1. Fisher CVX



**CVX WITH WELDED DIFFUSER**

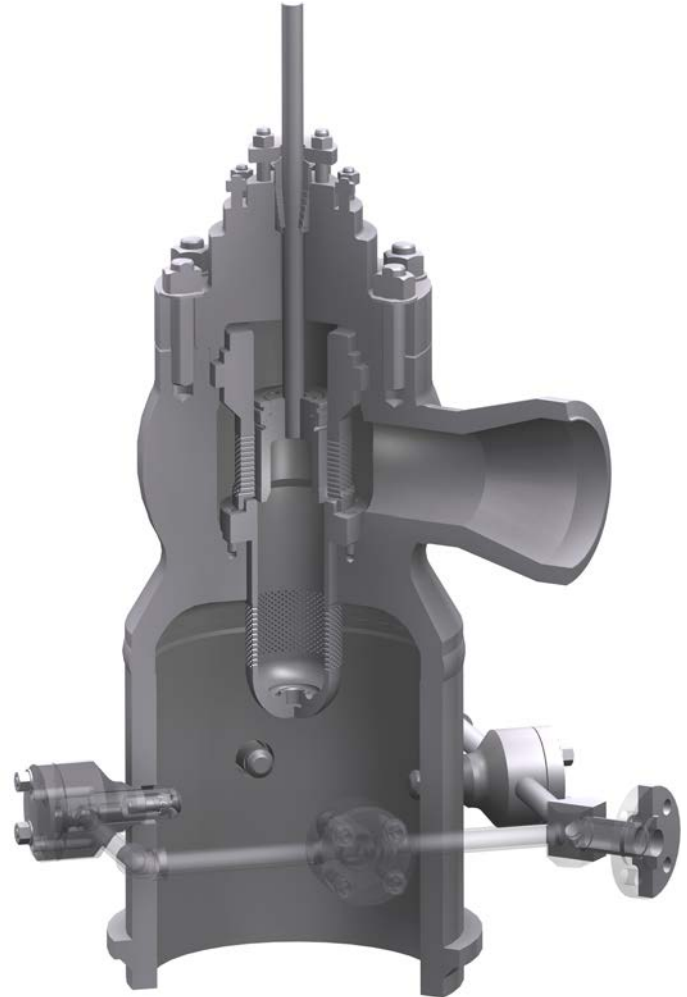

**CVX WITH BOLTED SEAT RING DIFFUSER**

## Ordering Information

### Application Information

When ordering, specify:

1. Steam Flow, PPH (Inlet/Outlet)
2. Inlet Pressure, PSIA
3. Outlet Pressure, PSIA
4. Inlet Temperature, °F
5. Outlet Temperature, °F
6. Water Pressure, PSIA
7. Water Temperature, °F
8. Required Noise Level, dBA
9. Pipeline Size, inches (Inlet/Outlet)
10. Turndown Required

Figure 2. Fisher CVX Bore Seal Trim in Closed Position

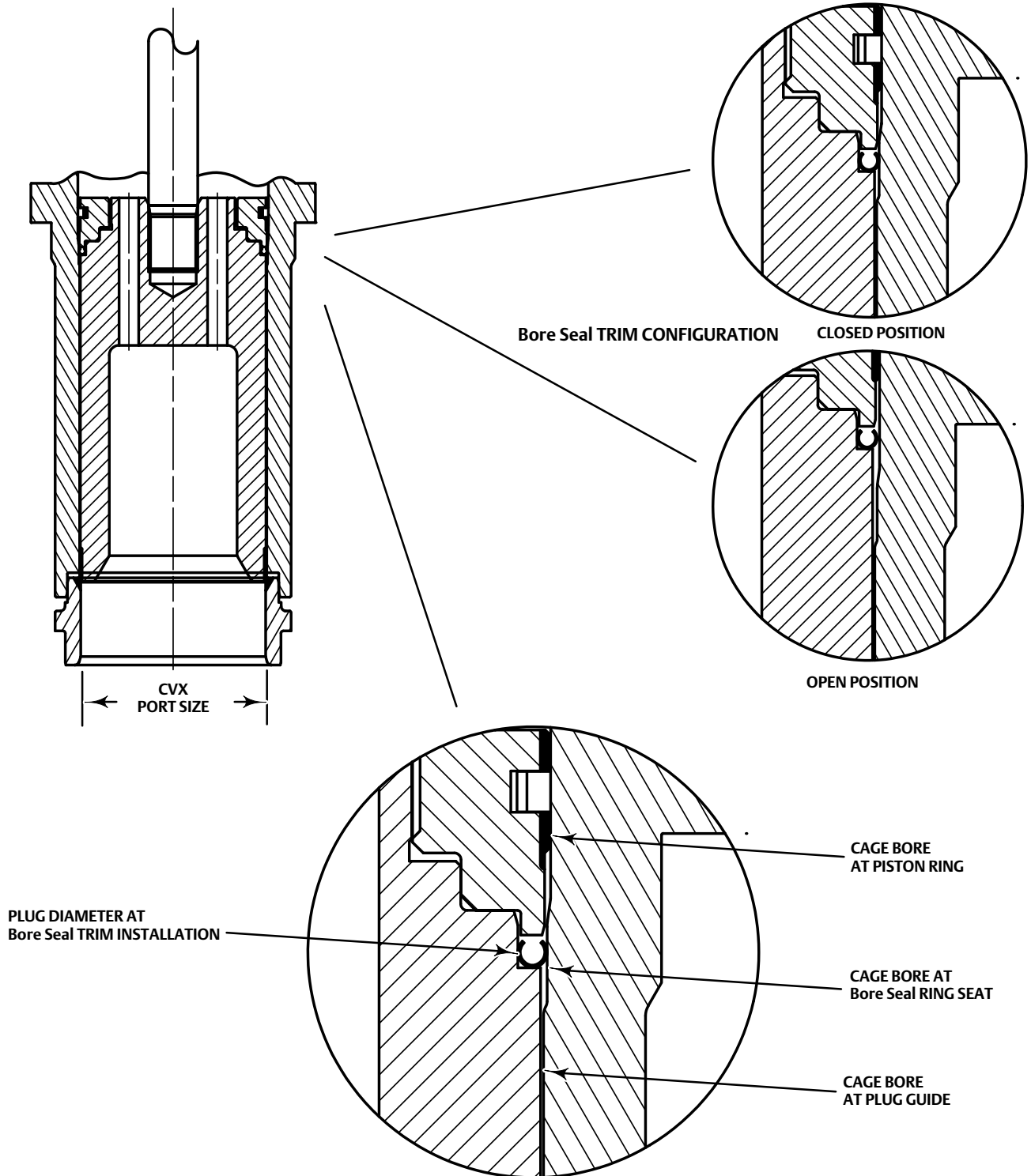

E0921

## Product Bulletin

85.1:CVX  
September 2017

**CVX Valve**  
D101423X012

---

Neither Emerson, Emerson Automation Solutions, nor any of their affiliated entities assumes responsibility for the selection, use or maintenance of any product. Responsibility for proper selection, use, and maintenance of any product remains solely with the purchaser and end user.

Fisher is a mark owned by one of the companies in the Emerson Automation Solutions business division of Emerson Electric Co. Emerson Automation Solutions, Emerson, and the Emerson logo are trademarks and service marks of Emerson Electric Co. All other marks are the property of their respective owners.

The contents of this publication are presented for informational purposes only, and while every effort has been made to ensure their accuracy, they are not to be construed as warranties or guarantees, express or implied, regarding the products or services described herein or their use or applicability. All sales are governed by our terms and conditions, which are available upon request. We reserve the right to modify or improve the designs or specifications of such products at any time without notice.

**Emerson Automation Solutions**  
Marshalltown, Iowa 50158 USA  
Sorocaba, 18087 Brazil  
Cernay 68700 France  
Dubai, United Arab Emirates  
Singapore 128461 Singapore

[www.Fisher.com](http://www.Fisher.com)

