

Fisher™ GX Control Valve and Actuator System

The Fisher GX is a compact, state-of-the-art control valve and actuator system, designed to control a wide range of process liquids, gases, and vapors.

The GX is rugged, reliable, and easy to select. It requires no actuator sizing -- the actuator selection is automatic once the valve body construction is selected.

The optimized design results in reduced complexity and parts count. As a result, the cost of maintenance is reduced.

The GX meets the requirements of both EN and ASME standards. It is available with a complete accessory package, including the Fisher FIELDVUE™ DVC2000 and DVC6200 integrated digital valve controllers.



W8861

Fisher GX Control Valve, Actuator, and
FIELDVUE DVC2000 Digital Valve Controller

Features

- Easy to size and select
- No actuator sizing required--selection is automatic
- Optimized actuator allows for a wide range of air supply
- Engineered for easy maintenance
- Maximum part commonality across sizes
- Replaceable trim
- Low lifetime costs
- Robust, low-profile design
- Compact multi-spring pneumatic actuator
- Available with integrated, easy-to-calibrate DVC2000 or DVC6200 digital valve controller
- Valve body sizes DN 15 to DN 150 (NPS 1/2 through 6)
- Pressure Classes PN 10-40, CL150 and 300
- High capacity design
- Valve body flow passage optimized for flow stability
- Full range of materials, including alloys
- Shutoff capabilities: Class IV, V, and VI
- Rangeability of 50:1 (equal percentage)
- Optional metal bellows seal
- ISO 5210 F7 mounting available for use with electric actuators

Figure 1. Fisher GX Control Valve Assembly with Port-Guided Contoured Plug (Port Sizes 36 to 136 mm)

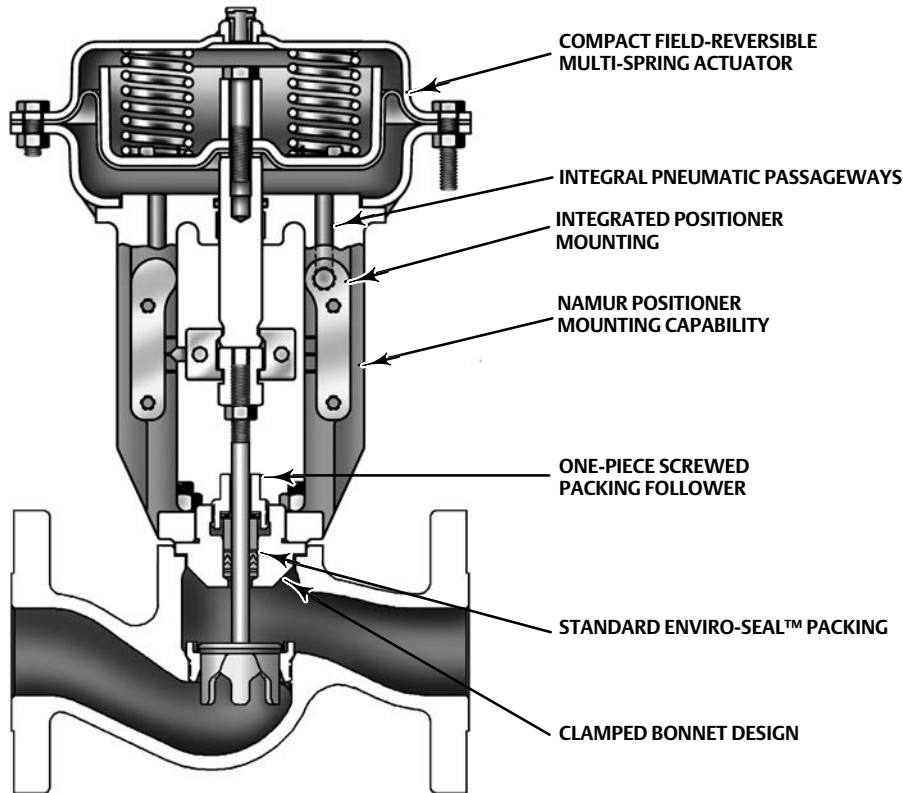

W8568-1A

Optimized valve and actuator system. Product simplicity and ease of selection form the foundation of the GX. Mounted with a digital or analog positioner, the GX provides high performance control across a wide range of process applications.

Compact actuator design. The GX utilizes a compact, multi-spring actuator. The GX design has been optimized to eliminate complicated actuator sizing procedures - once the valve body, port size, and air

supply pressure are selected, the actuator size is fixed.

Modular design. The design architecture has been optimized to maximize the use of common parts across sizes. The actuator stem and stem connector are used across all GX sizes. The GX actuator uses a total of 5 different springs across all valve sizes. These spring sets have been optimized to allow for maximum application coverage. The plug/stem assemblies and ENVIRO-SEAL packing sets are common across several sizes, as well.

Contents

Features	1	The Fisher GX Diaphragm Actuator	16
Principle of Operation	4	GX ISO 5210 Electric Actuator Mounting	17
The Fisher GX Control Valve	6	Bellows Extension Bonnet	17
Fisher GX Control Valve Specifications and Materials of Construction	7	Valve-Actuator Dimensions and Weights	22
GX Cavitrol™ III for DN25 (NPS 1) through DN50 (NPS 2)	15	Fisher GX Actuator Accessories	25
GX Whisper Trim™ III for DN80 (NPS 3) through DN150 (NPS 6)	15	The Fisher FIELDVUE DVC2000 Digital Valve Controller	25
		Optional Positioners and Instruments	26
		Manual Handwheels	27

Figure 2. Fisher GX and DVC2000 Digital Valve Controller

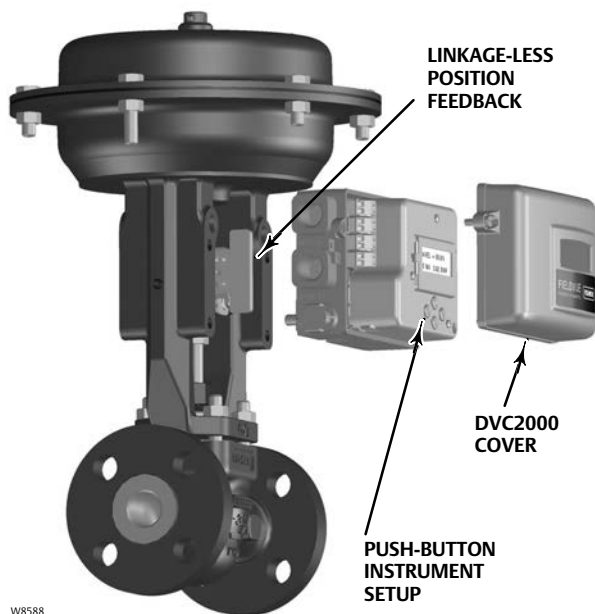

Low lifetime costs. Reduced product complexity, low parts count, and part commonality all contribute to reduced inventory and maintenance costs.

Stable flow control. The flow cavity of the GX valve body has been engineered to provide stable flow and reduce process variability.

Emission Requirements— ENVIRO-SEAL packing systems provide an improved stem seal to help prevent the loss of valuable or hazardous process fluid. The GX comes standard with ENVIRO-SEAL PTFE packing. For applications exceeding 232°C (450°F), ENVIRO-SEAL graphite ULF packing and extension bonnets are available.

Figure 3. Fisher GX Cryogenic Valve



Easy maintenance. The simple screwed seat-ring and one-piece plug and stem design provide easy maintenance. Design simplicity and parts commonality contribute to reduced spares inventory. The integrated DVC2000 and DVC6200 digital valve controllers allow easy instrument removal, without a requirement for tubing disconnection or replacement (fail-down construction).

Long life. Alloy valve constructions and hardened trim materials are available in the GX to increase valve body, bonnet, and trim life.

Cryogenic offering. The GX is available in a low temperature construction (see figure 3). The compact design maintains high performance in low temperature applications, while minimizing overall envelope size.

Long face-to-face offering. The GX is available in ISA-S75.08.07 long face-to-face dimensions for DN25 to 50 (NPS 1 to 2). All GX control valves have integral flanges, providing replacement for separable flange and other long face-to-face valves.

Figure 4. Fisher GX Principle of Operation -- Actuator Air Supply

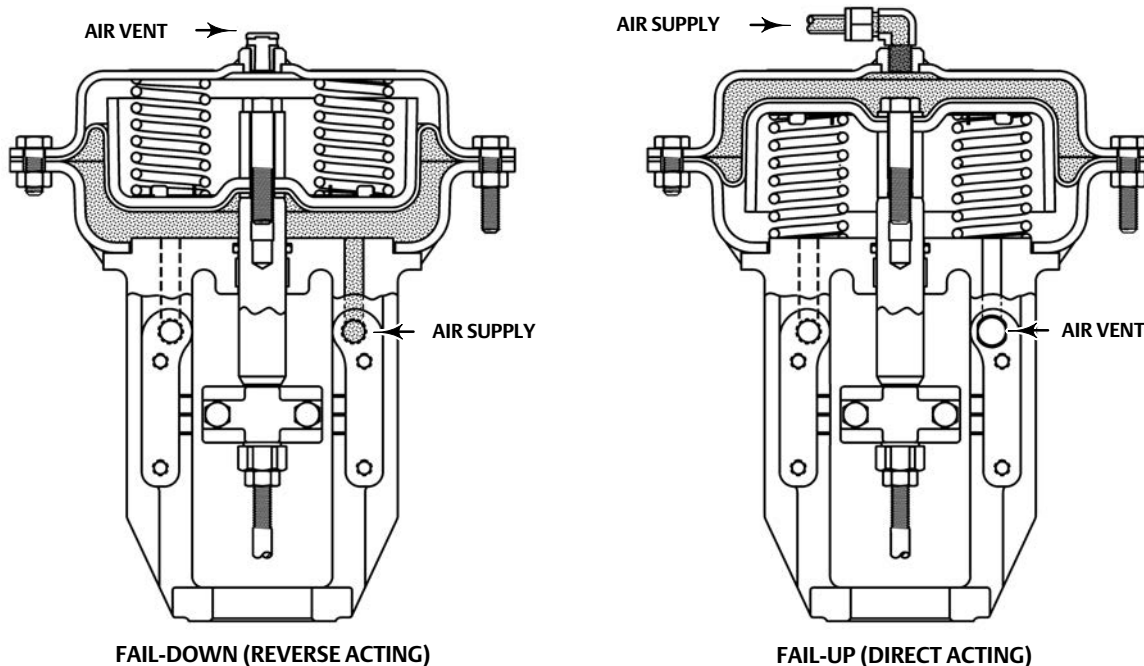

Digital valve controller. The GX is available with the DVC2000 digital valve controller. The DVC2000 is easy to use, compact, and designed for easy mounting. It converts a 4-20 mA input signal into a pneumatic output signal, which feeds the control valve actuator. Instrument setup is performed with a push button and LCD interface. This interface is protected from the environment within a sealed enclosure. The interface supports multiple languages, including German, French, Italian, Spanish, Chinese, Japanese, Portuguese, Russian, Polish, Czech, Arabic, and English.

Intrinsic safety and non-incendive construction is available to CSA, FM, ATEX, and IEC standards. An optional module provides integrated limit switches and a position transmitter.

Integrated mounting. The DVC2000 and DVC6200 digital valve controllers integrally mount to the GX actuator, eliminating the need for mounting brackets. The DVC2000 transmits a pneumatic signal to the actuator casing via an air passage in the yoke leg, causing the valve to stroke (see figure 4). This eliminates the need for positioner-to-actuator tubing in the fail-down configuration.

The DVC2000 and DVC6200 mounting interfaces are identical on both sides of the actuator yoke for valve body sizes DN 15 through DN 100 (NPS 1/2 through 4).

This symmetrical design allows the DVC2000 to be easily moved from one side of the valve to the other without the need to rotate the actuator. The DN 150 (NPS 6) yoke is not symmetrical.

Linkage-less feedback. The DVC2000 and DVC6200 digital valve controllers offer as standard a non-contacting valve position feedback system. This is a true linkage-less design, which uses no levers and no touching parts between the valve stem and the positioner.

Additional Accessory selection. The GX is available with a variety of digital or analog positioners besides the DVC2000 or DVC6200, as well as solenoid and limit switches. The actuator is also compatible with the IEC 60534-6-1 (NAMUR) positioner mounting standard.

Principle of Operation

Integrated Air Supply. When mounted with the DVC2000 digital valve controller, the GX uses an integrated actuator air supply system. In the fail-down construction, air is supplied to the lower actuator casing via a port on the actuator yoke face -- no tubing is required. In the fail-up configuration, air is supplied to the upper casing via tubing.

Figure 5. Fisher GX Control Valve with Typical Soft Seat Trim Construction (DN 25 to 150 and NPS 1 to 6, Port Sizes of 22 - 136mm)

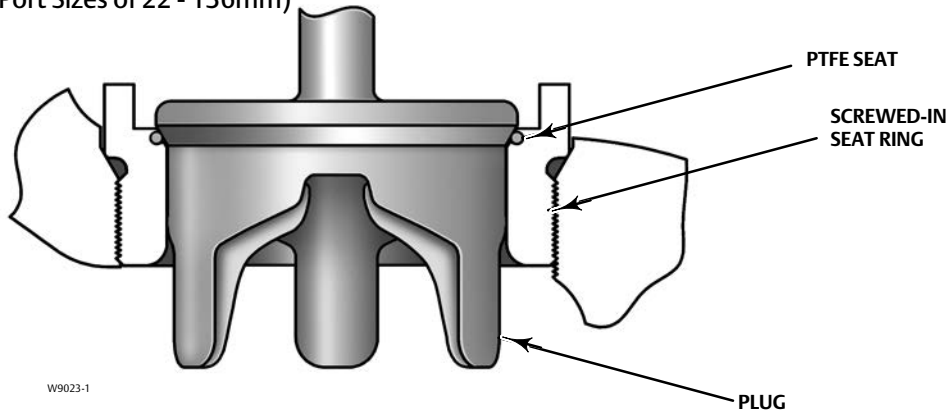

Figure 6. Fisher GX Control Valve with Port-Guided Plug (DN 40 to 150 and NPS 1-1/2 to 6, Port Sizes of 36 - 136mm)

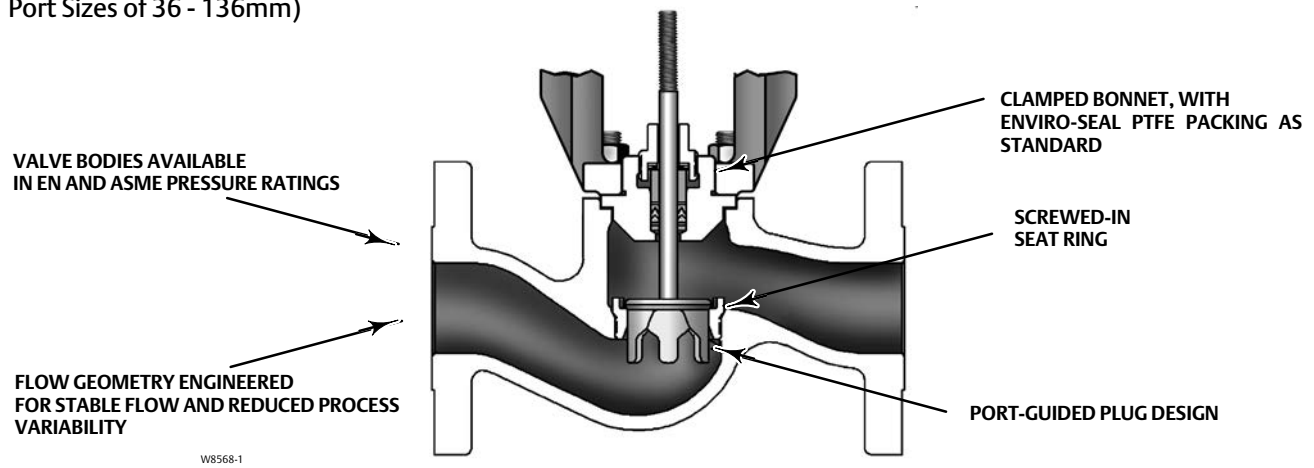

Figure 7. Fisher GX Control Valve with Balanced Trim (DN 80 to 150 and NPS 3 to 6, Port Sizes of 70, 90, and 136 mm Only)

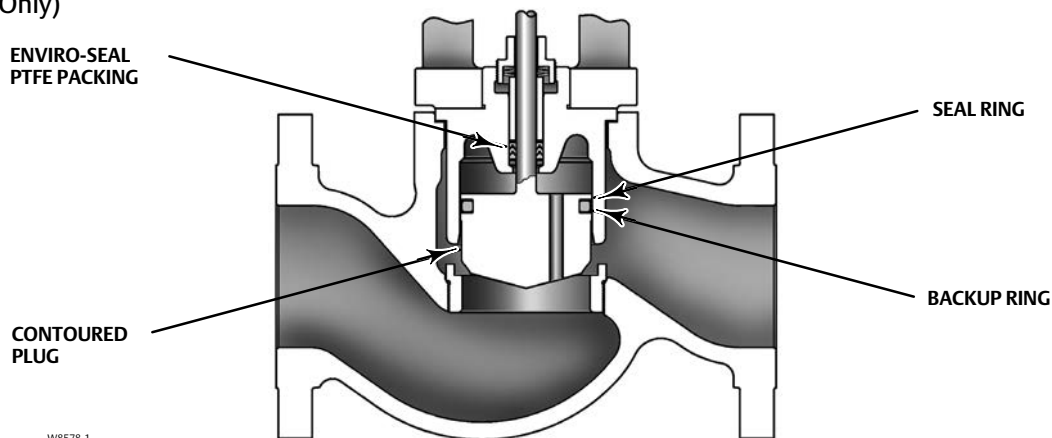
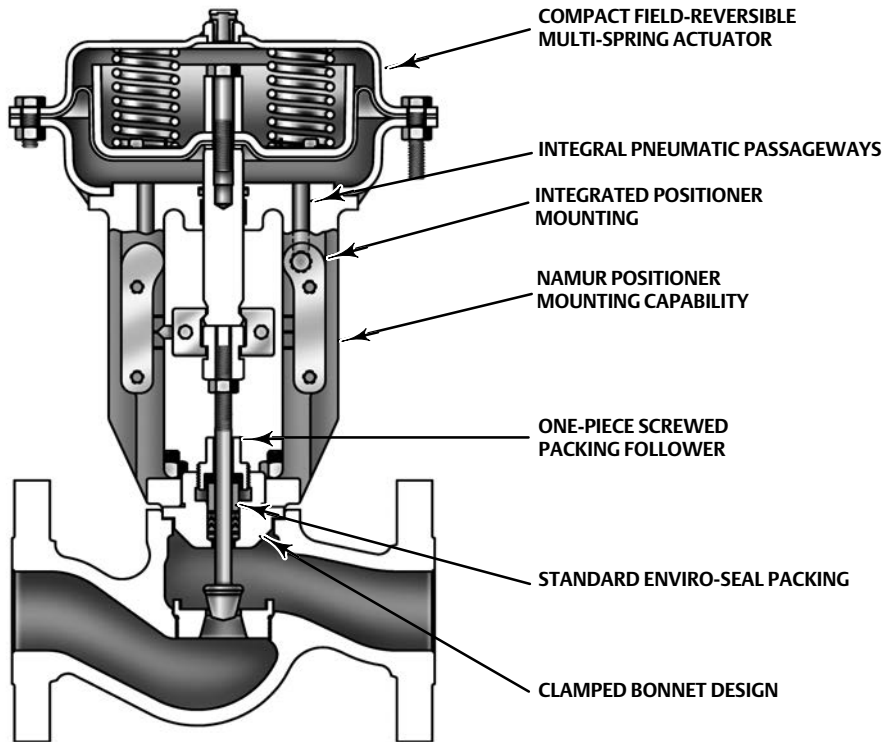

Figure 8. Fisher GX Control Valve Assembly with Stem-Guided Contoured Plug (Size DN 25 and NPS 1)



W8486-3

The Fisher GX Control Valve

The GX is a single port, flow-up globe style valve that offers port-guided (figure 1), stem-guided (figure 8), and balanced trim with a screwed-in seat ring (see table 1 for a description of trim style availability). Each valve size offers an unbalanced plug design, which eliminates dead spaces where fluid polymerization might occur. Although the optimized GX actuator allows for wide usage of unbalanced trim, a balanced plug design is available for higher pressure drop applications in DN80, 100 and 150 (NPS 3, 4, and 6) sizes.

The GX incorporates a clamped bonnet and an easy-to-adjust screwed packing follower (see figure 1).

The plug and stem are a rugged, one-piece welded assembly.

The standard construction incorporates metal-to-metal seating, with a PTFE soft seat option for Class VI shutoff (see figure 5). Class V shutoff is available with metal trim. Hardened trim with stellite overlay is available for erosive service, as well.

Both linear and equal percentage flow characteristics are available in full port and restricted trim. Micro-Flow is available for applications requiring low flow control capability.

Standard valve body materials are carbon steel and stainless steel. Alloy materials are available for valve body sizes DN 15 through DN 100 (NPS 1/2 through 4) for corrosive applications.

Fisher GX Control Valve Specifications and Materials of Construction

See tables 1 and 2.

Table 1. Fisher GX Valve Specifications

Specifications	EN	ASME
Valve Body Size	DN 15, 20, 25, 40, 50, 80, 100, 150	NPS 1/2, 3/4, 1, 1-1/2, 2, 3, 4, 6
Pressure Rating	PN 10 / 16 / 25 / 40 per EN 1092-1	CL150 / 300 per ASME B16.34
End Connections	Flanged raised face per EN 1092-1	Flanged raised face per ASME B16.5
Valve Body/Bonnet Materials	1.0619 steel	ASME SA216 WCC steel
	1.4409 stainless steel	ASME SA351 CF3M stainless steel
	CW2M (sizes DN 25 through DN 100 only)	CW2M (NPS 1 through 4 only)
	ASME SA352 LCC	ASME SA352 LCC
	ASTM A990 CN3MCu/ASME SA351 CN7M (Cast Alloy 20) (sizes DN 25 through DN 100 only)	ASTM A990 CN3MCu/ASME SA351 CN7M (Cast Alloy 20) (NPS 1 through 4 only)
	CD3MN Duplex SST (sizes DN 25 through DN 100 only)	CD3MN Duplex SST (NPS 1 through 4 only)
	CF3 304L SST (sizes DN 25 through DN 100 only)	CF3 304L SST (NPS 1 through 4 only)
		M35-2 (NPS 1 through 4 only)
Face-to-Face Dimensions	Consistent with EN 558-1 Series 1	Consistent with ANSI/ISA 75.08.01
Long Face-to-Face Dimensions		Consistent with ANSI/ISA 75.08.07
Shutoff per IEC 60534-4 and ANSI/FCI 70-2	Metal seat - Class IV (standard)	
	Metal seat - Class V (optional)	
	PTFE seat - Class VI (optional) ⁽¹⁾	
Flow Direction	Flow-up (Cavitrol III trim, Flow down)	
Flow Control Characteristics	Equal Percentage and Linear	
Flow Coefficients	See Fisher Catalog 12	
Trim Style	Port Diameters	Trim Style Description
	4.8 mm	Micro-Flow trim (unbalanced)
	9.5, 14, 22 mm	Stem-Guided with Contoured Plug (unbalanced) or Port-Guided with Cavitrol III trim (unbalanced)
	36, 46 mm	Port-Guided Plug (unbalanced)
	70, 90, 136 mm	Balanced Trim with Contoured plug or Unbalanced Port-Guided Plug
Handwheel	Available as an option	
Travel Stop	Available as an option	
1. For 4.8 to 14 mm ports, Class VI shutoff is achieved without PTFE seat.		

Table 2. Materials (Other Valve Components)

Component	Material	
Packing Follower	S21800 SST screwed follower	
Body/Bonnet Bolting and Nuts	SA193-B7 studs / SA194-2H nuts with NCF2 coating for carbon steel and stainless steel constructions	
	DN 15 through DN 100: S20910 (XM19) for alloy (standard) and stainless steel assemblies (optional) DN 150: SA193-B7M studs / SA194-2HM nuts with NCF2 coating (optional)	
Packing	ENVIRO-SEAL Live-loaded PTFE V-ring (standard) with N07718 Belleville springs	
	ENVIRO-SEAL Live-loaded Graphite ULF (optional) with N07718 Belleville springs	
Bonnet Gasket	DN 15 through DN 150: Graphite laminate	
	DN 15 through DN 100: PTFE encapsulated N10276 (optional) Applicable from -46 to 232°C (-50 to 450°F) (May be preferable when the standard graphite laminate gasket material is not compatible with the process fluid)	
NACE MR0175/ISO15156 ⁽¹⁾ and NACE MR0103 Construction	DN 15 through DN 100	Stainless steel, or carbon steel valve bodies and bonnets
		SA193-B7 studs / SA194-2H nuts with NCF2 coating (S20910 SST optional) body/bonnet bolting
		Standard ENVIRO-SEAL live-loaded PTFE packing
	DN 150	S31603/CoCr-A plug, S20910 stem, and S31603/CoCr-A seat ring SA193-B7M studs / SA194-2HM nuts with NCF2 coating
Balanced Trim (Sizes DN 80, 100, and 150 / NPS 3, 4, and 6)	Back-up Rings	Carbon-Filled PTFE Seal Ring
		Nitrile (Standard) -46 to 82°C (-50 to 180°F)
		Ethylene Propylene [EPDM] (Optional): -46 to 232°C (-50 to 450°F) in steam and hot water; -46 to 121°C (-50 to 250°F) in air (EPDM is not recommended for use in hydrocarbons)
		FKM (fluorocarbon) (Optional): -18 to 204°C (0 to 400°F) (Applicable in a wide variety of solvents, chemicals, and hydrocarbons. Avoid use with steam, ammonia, or hot water over 82°C [180°F])

1. Environmental restrictions may apply.

Table 3. Trim Materials for Port Diameters of 4.8 mm (Micro-Flow trim) (Unbalanced Trim)

Valve Body Construction	Trim Type	Stem	Plug	Seat
Carbon steel (1.0619 / WCC and LCC)	Metal to metal	S31603 strain hardened	R31233	SA351 CF3M
	Hard-faced	S20910	R31233	SA351 CF3M / CoCr-A seat
	Metal to metal	N06022	R31233	CW2M
Stainless steel (1.4409 / CF3M)	Metal to metal	S31603 strain hardened	R31233	SA351 CF3M
	Hard-faced	S20910	R31233	SA351 CF3M / CoCr-A seat
	Metal to metal	N06022	R31233	CW2M
Carbon steel to NACE MR0175/ISO15156 ⁽²⁾ and NACE MR0103 (1.0619 / WCC and LCC)	Hard-faced	S20910	R31233	SA351 CF3M / CoCr-A seat
Stainless steel to NACE MR0175/ISO15156 ⁽²⁾ and NACE MR0103 (1.4409 / CF3M)	Hard-faced	S20910	R31233	SA351 CF3M / CoCr-A seat
CW2M and CN3MCu/CN7M ⁽¹⁾	Metal to metal	N06022	R31233	CW2M
Duplex SST (CD3MN) ⁽¹⁾	Metal to metal	S31803 (Duplex SST)	R31233	CD3MN (Duplex SST)
304L SST (CF3) ⁽¹⁾	Metal to metal	S31803 (Duplex SST)	R31233	CF3 (304L SST)

1. Not available in DN 15 and DN 20 (NPS 1/2 and 3/4) sizes.

2. Environmental restrictions may apply.

Table 4. Trim Materials for Port Diameters of 9.5 and 14 mm (Unbalanced Trim)

Valve Body Construction	Trim Type	Stem	Plug	Seat
Carbon steel (1.0619 / WCC and LCC)	Metal to metal	S31603 strain hardened	S31603	SA351 CF3M
	Hard-faced	S20910	S31603 / CoCr-A seat	SA351 CF3M / CoCr-A seat
	Metal to metal	N06022	N06022	CW2M
Stainless steel (1.4409 / CF3M)	Metal to metal	S31603 strain hardened	S31603	SA351 CF3M
	Hard-faced	S20910	S31603 / CoCr-A seat	SA351 CF3M / CoCr-A seat
	Metal to metal	N06022	N06022	CW2M
Carbon steel to NACE MR0175/ISO15156 ⁽²⁾ and NACE MR0103 (1.0619 / WCC and LCC)	Hard-faced	S20910	S31603 / CoCr-A seat	SA351 CF3M / CoCr-A seat
Stainless steel to NACE MR0175/ISO15156 ⁽²⁾ and NACE MR0103 (1.4409 / CF3M)	Hard-faced	S20910	S31603 / CoCr-A seat	SA351 CF3M / CoCr-A seat
CW2M and CN3MCu/CN7M ⁽¹⁾	Metal to metal	N06022	N06022	CW2M
Duplex SST (CD3MN) ⁽¹⁾	Metal to metal	S31803 (Duplex SST)	S31803 (Duplex SST)	CD3MN (Duplex SST)
304L SST (CF3) ⁽¹⁾	Metal to metal	S31803 (Duplex SST)	S30403 (304L SST)	CF3 (304L SST)
M35-2 ⁽¹⁾	Metal to metal	N05500	N05500	N05500
N7M (Alloy B2) ⁽¹⁾	Metal to metal	N10675 (Alloy B3)	N10675 (Alloy B3)	N7M (Alloy B2)

1. Not available in DN 15 and DN 20 (NPS 1/2 and 3/4) sizes.
2. Environmental restrictions may apply.

Table 5. Trim Materials for Port Diameters of 22, 36, 46, 70, 90, and 136 mm (Unbalanced Trim)

Valve Body Construction	Trim Type	Stem	Plug	Seat
Carbon steel (1.0619 / WCC and LCC)	Metal to metal	S31603 strain hardened	S31603	SA351 CF3M ⁽³⁾
	Soft seat	S31603 strain hardened	S31603	SA351 CF3M / PTFE seat ⁽⁴⁾
	Hard-faced/ Whisper Trim III ⁽²⁾	S20910	S31603 / CoCr-A seat	SA351 CF3M/CoCr-A seat (22 mm) SA351 CF3M/CoCr-A seat and guide (>22 mm)
	Cavitrol III trim	S20910	S31603/CoCr-A seat	S17400 Cage
	Metal to metal	N06022	N06022	CW2M ⁽¹⁾
	Soft seat	N06022	N06022	CW2M / PTFE seat ⁽¹⁾
Stainless steel (1.4409 / CF3M)	Metal to metal	S31603 strain hardened	S31603	SA351 CF3M ⁽³⁾
	Soft seat	S31603 strain hardened	S31603	SA351 CF3M / PTFE seat ⁽⁴⁾
	Hard-faced/ Whisper Trim III ⁽²⁾	S20910	S31603 / CoCr-A seat	SA351 CF3M/CoCr-A seat (22 mm) SA351 CF3M/CoCr-A seat and guide (>22 mm)
	Cavitrol III trim	S20910	S31603/CoCr-A seat and guide	S17400 Cage
	Metal to metal	N06022	N06022	CW2M ⁽¹⁾
	Soft seat	N06022	N06022	CW2M / PTFE seat ⁽¹⁾
Carbon steel to NACE MR0175/ISO15156 ⁽⁵⁾ and NACE MR0103 (1.0619 / WCC and LCC)	Hard-faced	S20910	S31603 / CoCr-A seat	SA351 CF3M/CoCr-A seat (22 mm) SA351 CF3M/CoCr-A seat and guide (>22 mm)
Stainless steel to NACE MR0175/ISO15156 ⁽⁵⁾ and NACE MR0103 (1.4409 / CF3M)	Hard-faced	S20910	S31603 / CoCr-A seat	SA351 CF3M/CoCr-A seat (22 mm) SA351 CF3M/CoCr-A seat and guide (>22 mm)
CW2M and CN3MCu/CN7M ⁽¹⁾	Metal to metal	N06022	N06022	CW2M
	Soft seat	N06022	N06022	CW2M / PTFE seat
Duplex SST (CD3MN) ⁽¹⁾	Metal to metal	S31803 (Duplex SST)	S31803 (Duplex SST)	CD3MN (Duplex SST)
	Soft seat	S31803 (Duplex SST)	S31803 (Duplex SST)	CD3MN (Duplex SST)/ PTFE seat ⁽¹⁾
304L SST (CF3) ⁽¹⁾	Metal to metal	S31803 (Duplex SST)	S30403 (304L SST)	CF3 (304L SST)
	Soft seat	S31803 (Duplex SST)	S30403 (304L SST)	CF3 (304L SST)/ PTFE seat ⁽¹⁾
M35-2 ⁽¹⁾	Metal to metal	N05500	N05500	N05500
N7M (Alloy B2) ⁽¹⁾	Metal to metal	N10675 (Alloy B3)	N10675 (Alloy B3)/ N7M (>22 mm)	N7M (Alloy B2)

1. Not available for DN 150 (NPS 6).
2. Whisper Trim III is only available in 70 and 90 mm ports.
3. DN150 (NPS 6) has CoCr-A seat and guide.
4. DN150 (NPS 6) has CoCr-A guide.
5. Environmental restrictions may apply.

Table 6. Trim Materials for Port Diameters of 70, 90, and 136 mm (Balanced Trim)⁽³⁾

Valve Body Construction	Trim Type	Stem	Plug	Seat
Carbon steel (1.0619 / WCC and LCC) ⁽¹⁾	Metal to metal	S31603 strain hardened	S31603	SA351 CF3M
	Hard-faced/ Whisper Trim III ⁽⁴⁾	S20910	S31603 / CoCr-A seat and guide	SA351 CF3M / CoCr-A seat and guide
	Metal to metal	N06022	N06022	CW2M ⁽²⁾
Stainless steel (1.4409 / CF3M)	Metal to metal	S31603 strain hardened	S31603	SA351 CF3M
	Hard-faced/Whisper Trim III ⁽⁴⁾	S20910	S31603 / CoCr-A seat and guide	SA351 CF3M / CoCr-A seat and guide
	Metal to metal	N06022	N06022	CW2M ⁽²⁾
Carbon steel to NACE MR0175/ISO15156 ⁽⁵⁾ and NACE MR0103 (1.0619 / WCC and LCC)	Hard-faced	S20910	S31603 / CoCr-A seat	SA351 CF3M / CoCr-A seat and guide
Stainless steel to NACE MR0175/ISO15156 ⁽⁵⁾ and NACE MR0103 (1.4409 / CF3M)	Hard-faced	S20910	S31603 / CoCr-A seat	SA351 CF3M / CoCr-A seat and guide
CW2M and CN3MCu/CN7M ⁽²⁾	Metal to metal	N06022	N06022	CW2M
Duplex SST (CD3MN) ⁽²⁾	Metal to metal	S31803 (Duplex SST)	S31803 (Duplex SST)	CD3MN (Duplex SST)
304L SST (CF3) ⁽²⁾	Metal to metal	S31803 (Duplex SST)	S30403 (304L SST)	CF3 (304L SST)

1. The bonnet used in the carbon steel balanced trim construction is made of 1.4409/CF3M stainless steel.
 2. Not available for DN 150 (NPS 6).
 3. Balanced trim not available with M35-2 or N7M trim.
 4. Balanced Whisper Trim III in DN150 (NPS 6) 136 mm port diameter only.
 5. Environmental restrictions may apply.

Table 7. Fisher GX Availability

VALVE SIZE	PORT SIZE	STEM DIAMETER	TRAVEL	ACTUATOR SIZE
	mm	mm	mm	
DN15 (NPS 1/2)	9.5	10	20	Plain
DN20 (NPS 3/4)	14		20	Plain
	9.5		20	Plain
DN25 (NPS 1)	22		20	Plain
	14		20	Plain
	9.5		20	Plain
DN40 (NPS 1-1/2)	36		20	Plain
	22		20	Plain
	14		20	Plain
	46		20	Plain
DN50 (NPS 2)	36		20	Plain
	22		20	Plain
	70	40	Plain	
DN80 (NPS 3)	46	14	20	Plain
	36		20	Plain
	90		40	Plain
DN100 (NPS 4)	70		40	Plain
	46		20	Plain
	136		60	Plain
DN150 (NPS 6)	90	19	40	Plain

Table 8. Allowable Temperature Ranges for Valve Body, Bonnet and Trim⁽¹⁾

VALVE BODY / BONNET MATERIAL	BONNET STYLE	ENVIRO-SEAL PACKING	GASKET	TRIM STYLE	TEMPERATURE			
					°C		°F	
					Min	Max	Min	Max
1.0619/SA216 WCC Steel	Standard	PTFE or Graphite ULF	Graphite laminate or PTFE / N10276	Metal to metal; hard-faced; soft seat	-29	232	-20	450
	Extension		Graphite laminate	Metal to metal; hard-faced	-29	371	-20	700
	Bellows		Graphite laminate or PTFE / N10276	Metal to metal; hard-faced; soft seat	-29	232	-20	450
			Graphite laminate	Metal to metal; hard-faced	-29	371	-50	700
1.4409/SA351 CF3M SST	Standard		Graphite laminate or PTFE / N10276	Metal to metal; hard-faced; soft seat	-46	232	-50	450
	Extension		Graphite laminate	Metal to metal; hard-faced	-46	371	-50	700
	Cryogenic Extension		Graphite laminate	Metal to metal; hard-faced	(2)	371	(2)	700
	Bellows		Graphite laminate or PTFE / N10276	Metal to metal; hard-faced; soft seat	-46	232	-50	450
Graphite laminate			Metal to metal; hard-faced	-46	371	-50	700	
CW2M	Standard		Graphite laminate or PTFE / N10276	Metal to metal; soft seat	-46	232	-50	450
	Bellows		Graphite laminate or PTFE / N10276	Metal to metal; soft seat	-46	232	-50	450
LCC	Standard		Graphite laminate or PTFE / N10276	Metal to metal; hard-faced; soft seat	-46	232	-50	450
	Extension	Graphite laminate	Metal to metal; hard-faced	-46	343	-50	650	
	Bellows	Graphite laminate or PTFE / N10276	Metal to metal; hard-faced; soft seat	-46	232	-50	450	
		Graphite laminate	Metal to metal; hard-faced	-46	343	-50	650	
CN3MCu/CN7M	Standard	PTFE	Graphite laminate or PTFE / N10276	Metal to metal; soft seat	-46	232	-50	450
304L SST (CF3)	Standard		Graphite laminate or PTFE / S30403	Metal to metal; soft seat	-46	232	-50	450
Duplex SST (CD3MN)	Standard		Graphite laminate or PTFE / N10276	Metal to metal; soft seat	-46	232	-50	450
M35-2	Standard		Graphite laminate or PTFE / N04400	Metal to metal	-46	232	-50	450
N7M (Alloy B2)	Standard		Graphite laminate or PTFE / N10276	Metal to metal	-46	232	-50	450

1. Back-up ring materials used in Sizes DN 80, 100, and 150 (NPS 3, 4, and 6) with balanced trim may be limited by temperature and application. See table 2.
2. Consult your [Emerson sales office](#) for minimum temperature limit.

Figure 9. Material Pressure/Temperature Curves

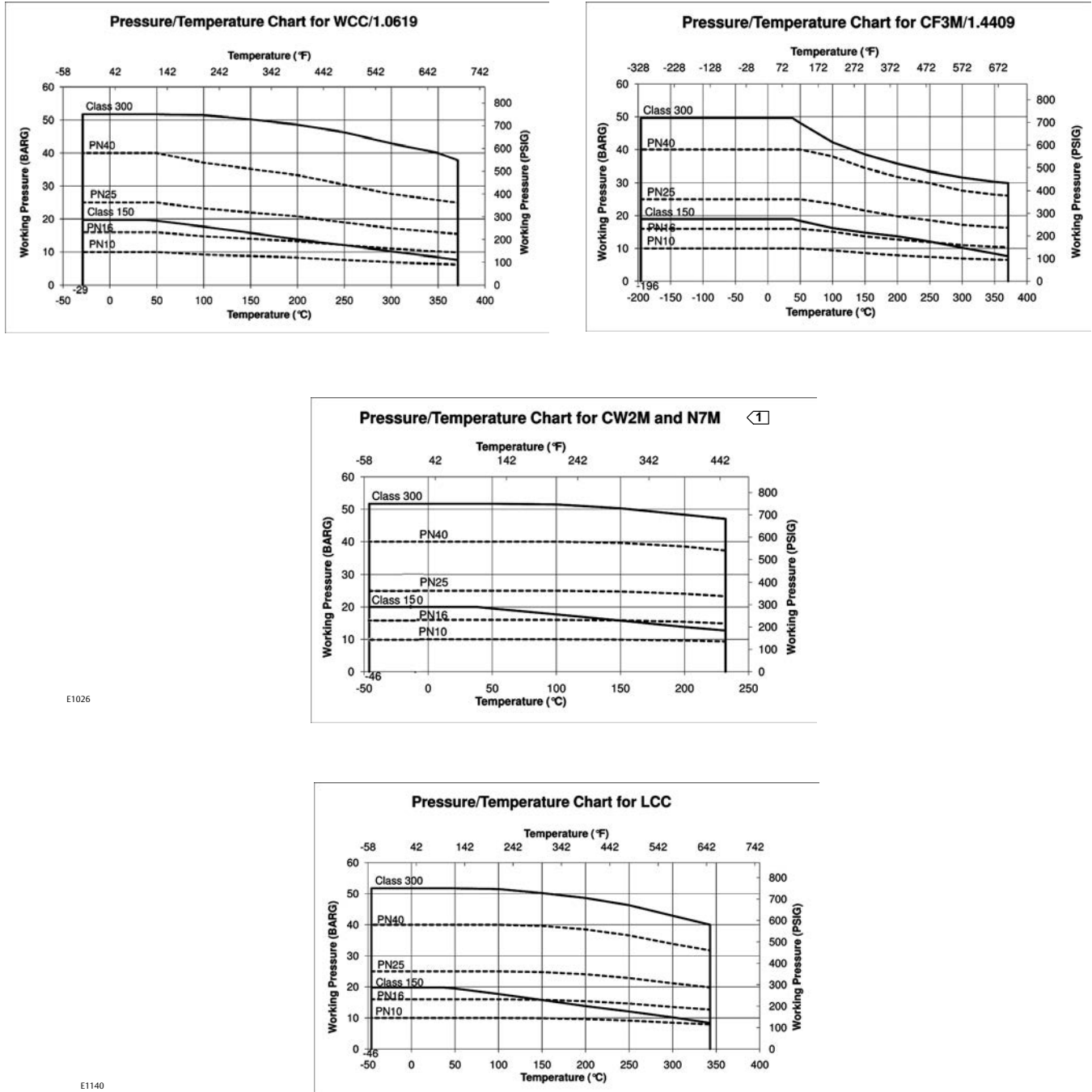

E1026

E1140

1. N7M is only offered with CL150 and CL300 (not PN10, PN16, PN25, or PN40).

Figure 10. Material Pressure/Temperature Curves

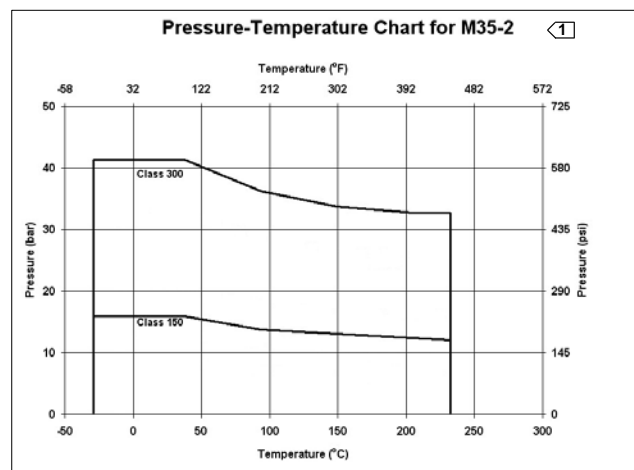
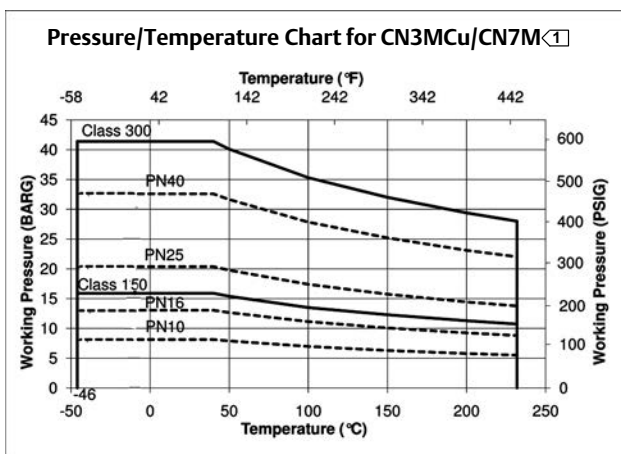
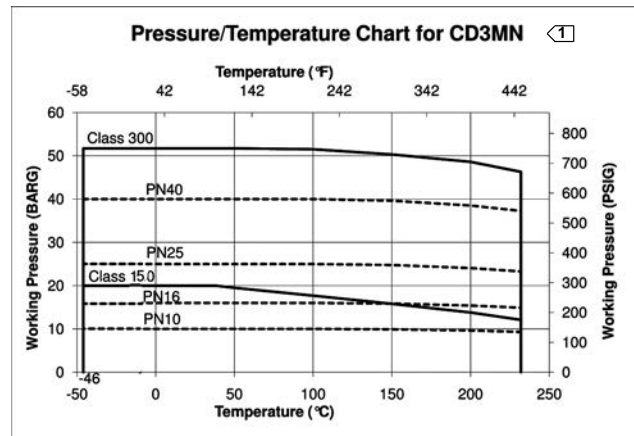
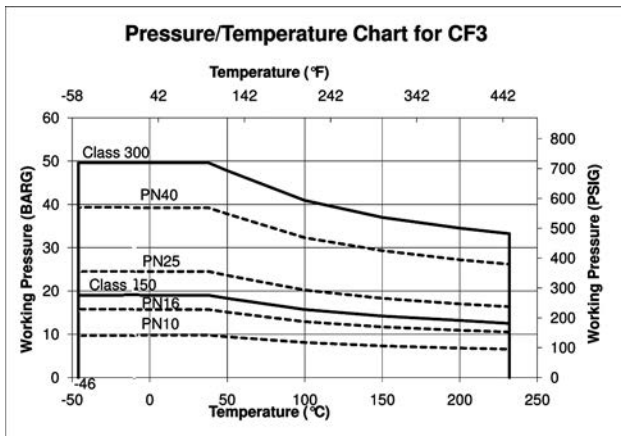

E0901

1. CD3MN, CN3MCu/CN7M, and M35-2 are not listed in EN 12516-1. The PN designations are used only to indicate relative pressure-retaining capabilities.

Figure 11. Fisher GX ENVIRO-SEAL Packing

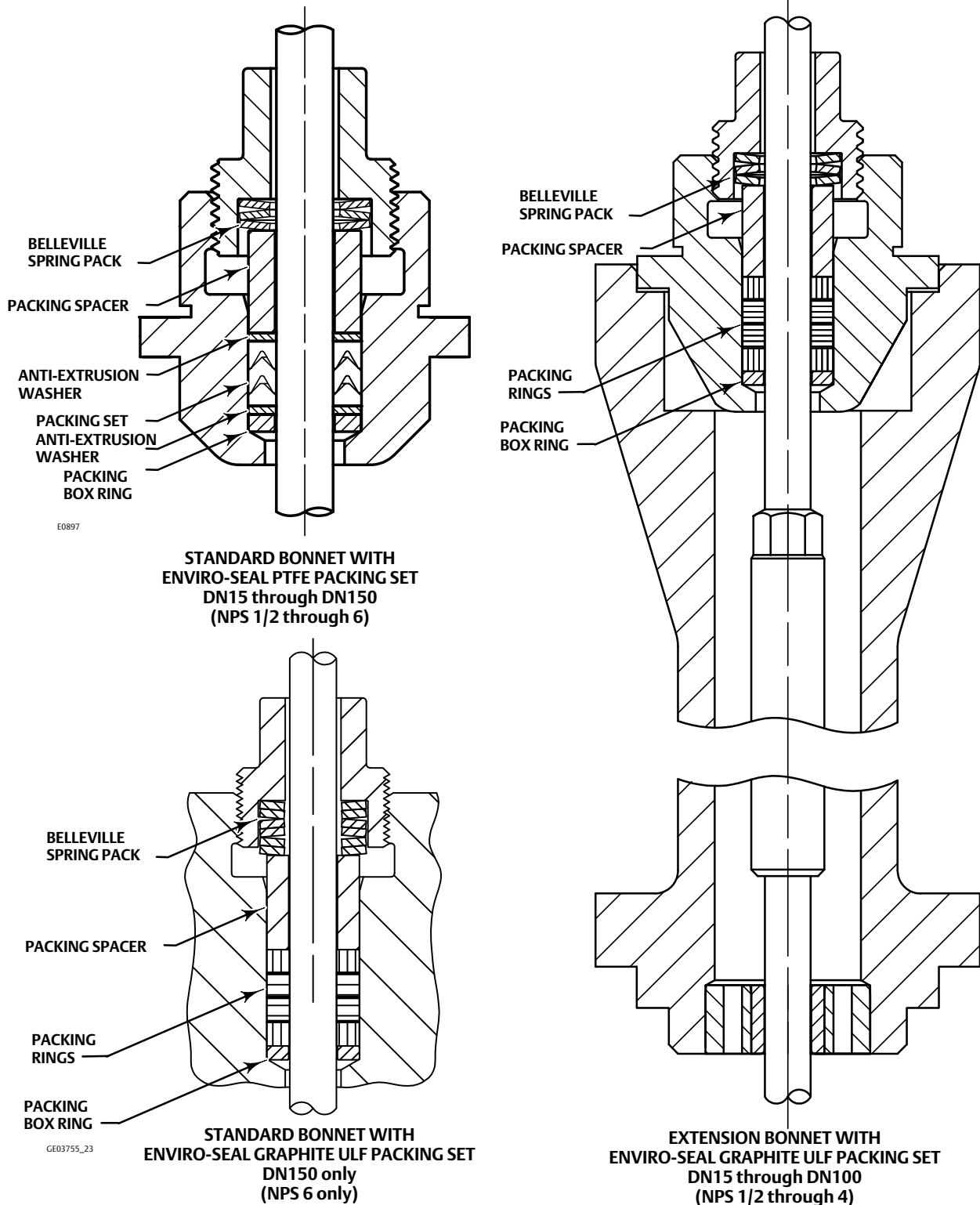

Figure 12. GX Cavitrol III Trim



GX Cavitrol III for DN25 (NPS 1) through DN50 (NPS 2)

Cavitrol III trim lowers hydrodynamic noise and reduces vibration by utilizing proprietary drilled hole shape and spacing to shift the frequency and isolate the cavitation in order to prevent damage. Cavitrol III 1-stage technology is used without altering the integral GX bonnet design.

Features

- Max delta-P of 400 psid
- Flow down
- Class V shutoff – standard

Available Sizes

- NPS 1, 225 Actuator, 20mm travel
- NPS 1-1/2, 750 Actuator, 20mm travel
- NPS 2, 750 Actuator, 20mm travel

Requirements

- Minimum 4 bar supply pressure
- Only available with standard bonnet

Table 9. Materials of Construction for Cavitrol III Trim

Part	Material
Stem	S20910
Plug	S31603 / CoCr-A Seat and Guide
Seat Ring / Cage	S17400

Figure 13. GX Whisper Trim III



GX Whisper Trim III for DN80 (NPS 3) through DN150 (NPS 6)

Whisper Trim III A1 lowers aerodynamic valve noise by utilizing multiple orifices of special shape, size, and spacing. These orifices break up turbulent compressible fluid streams and shift the acoustic energy to a higher frequency range. The result is about 20 dBA noise attenuation.

Features

- Flow up
- Class IV shutoff

Available Sizes

- NPS 3, 750 Actuator, 40mm travel
- NPS 4, 750 Actuator, 40mm travel
- NPS 6, 1200 Actuator, 60mm travel

Table 10. Materials of Construction for Whisper Trim III⁽¹⁾

Part	Material
Stem	S20910
Plug	S31603 / CoCr-A Seat
Seat Ring	S31603 / CoCr-A Seat and Guide
Cage ⁽¹⁾	CF3M

1. NPS 6 uses a separate cage, not integral to the plug stem.

Allowable temperature ranges are shown in table 8.

The Fisher GX Diaphragm Actuator

Figure 14. Fisher GX Actuator

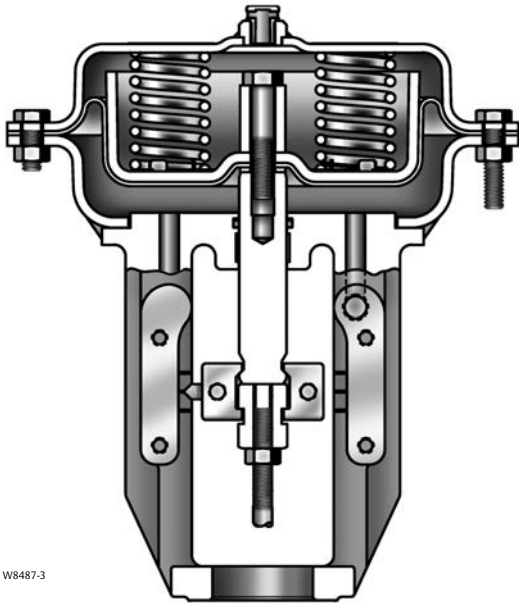

W8487-3

The GX uses a multi-spring, pneumatic diaphragm actuator (see figure 14). It is capable of air supply pressures to 6.0 barg (87 psig), allowing valve shutoff at high pressure drops.

The GX product selection system automatically matches the actuator to the valve, eliminating the need for complex actuator sizing procedures.

The multiple spring design provides the preload, eliminating the need for bench set adjustment. The actuator is available in spring-to-open and fail-down configurations.

The GX actuator can be used for throttling or on-off service.

The GX is available with the integrated DVC2000 digital valve controller. Other digital and analog positioners are available, as well as optional solenoids and limit switches.

Table 11. Actuator Specifications

Description	Pneumatic spring-return diaphragm actuator
Operating Principle	Air-to-open (standard) Air-to-close (optional)
Operating Pressure Ranges	2.0 to 6.0 barg (29 to 87 psig) ⁽¹⁾
Ambient Temperature	-46 to 82°C (-50 to 180°F)
Pressure Connection (Fail-up Construction)	G 1/4 female casing connection
Finish	Powder coat polyester
1. May vary depending on construction (see Fisher bulletin 51.1:GX (51) (D103209X012))	

Table 12. Materials of Construction

Part	Material
Upper and Lower Casings	AISI 1010 stamped carbon steel
Springs	Steel
Diaphragm	Nitrile and nylon
Diaphragm Plate	Size 225 and 750: AISI G10100 stamped carbon steel Size 1200: Cast carbon steel
Yoke	Carbon steel (stainless steel optional for some sizes)
Casing Fasteners	A2-70 stainless steel bolts and nuts
Actuator Rod	Stainless steel
Stem Connector	CF3M
Stem Connector Fasteners	SA193-B7 bolts with NCF2 coating
Stem Bushing	High-density polyethylene (HDPE)
Stem Seal	Nitrile

Actuator Selection

With the GX, actuator selection has never been easier. Once the valve size and port diameter have been determined, the actuator is automatically selected. No spring selection or bench set calculations are required.

The majority of GX constructions (both fail-down and fail-up) are rated to a full pressure class shutoff capability of 51.7 bar (750 psi) for a 4 to 6 bar (58 to 87 psig) actuator air supply. Refer to Fisher bulletin 51.1:GX (S1) ([D103209X012](#)) for additional information.

The GX actuator has been optimized to allow for varying ranges of supply pressure. See table 13.

Table 13. Fisher GX Actuator Supply Pressure Ranges

SUPPLY PRESSURE	RANGE	
	Bar	Psig
Standard	4.0 to 6.0	58 to 87
Optional	3.0 to 4.0	44 to 58
Optional	2.0 to 3.0	29 to 44

GX ISO 5210 Electric Actuator Mounting

Electric actuator mounting is available for any manufacturing models that comply with ISO 5210, Flange type F7. The mounting offering includes a GX yoke, actuator rod adaptor, spacer, and bolting.

CAUTION

The up travel stop must be set in the electric actuator in order to prevent damage to the valve trim.

Thrust limitations apply when sizing electric actuators (see table 14).

A mounting offering can be engineered if not already available for a selected actuator. Electric actuator mounting is not available for DN150, NPS 6 GX valves. For additional information, contact your [Emerson sales office](#) or Local Business Partner

Bellows Extension Bonnet

The GX bellows extension bonnet provides reliable and tight stem sealing for those applications where emissions escaping to the environment cannot be tolerated (see figure 15). The GX bellows is available in SST (1.4571 / 316Ti) or N10276 and covers a full range of valve sizes from DN 15 through DN 100 (NPS 1/2 through 4) (see tables 15 and 16).

The GX bellows system has been designed for 100,000 full-travel cycles at maximum allowable pressure and ambient temperature (20°C [68°F]).

The mechanically-formed metal bellows provides high operating reliability and extended cycle life (see tables 17, 18, and 19 for details).

The GX bellows design incorporates a rugged double- or triple-wall construction for added security. Each bellows is helium tested before leaving the factory.

The GX bellows bonnet comes standard with an ENVIRO-SEAL live-loaded, PTFE packing system as a security backup. A connection is provided above the bellows to allow purging or monitoring the integrity of the replaceable bellows.

Table 14. Fisher GX Maximum Allowable Thrust for use with ISO 5210 Electric Actuators

VALVE SIZE	STEM DIAMETER	TRAVEL	BONNET STYLE	STEM MATERIAL STRENGTH	MAXIMUM THRUST	
	mm	mm			N	lbf
DN15-DN50 (NPS 1/2 to 2)	10	20	Plain	High ⁽¹⁾	17000	3820
				Low ⁽²⁾	7600	1710
			Bellows/Extension	High	11400	2560
				Low	6700	1500
DN80-DN100 (NPS 3 to 4)	14	20, 40	Plain	High	20000	4500
				Low	20000	4500
			Bellows/Extension	High	20000	4500
				Low	14500	3260

1. High strength stem materials consist of S20910, N05500, S31603
2. Low strength stem materials consist of S31803, N10665, N06022

Figure 15. Fisher GX Bellows Bonnet and Selection Process

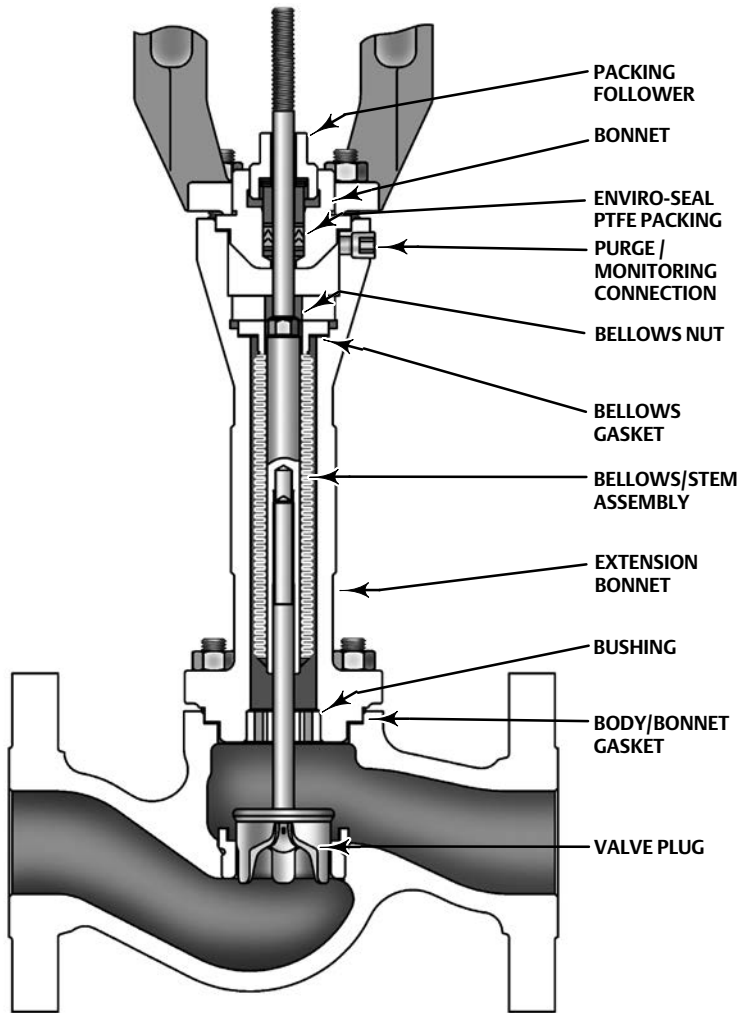

W8958-1

Bellows Selection Process

Follow this process to assist in selecting the appropriate bellows for the application.

Step 1

Size and select the GX control valve that is appropriate for the application. This will identify the:

- Valve body size
- Actuator size
- Orifice size
- Trim style (balanced or unbalanced)
- Valve body material



Step 2

Confirm bellows availability from table 15.



Step 3

Using table 16, select the bellows material combination that is appropriate for the application. Using the temperature limits shown in table 8, confirm the selected construction is appropriate for the application temperatures.



Step 4

Using bulletin 51.1:GX(S1), verify the application pressure drop does not exceed the actuator capability.



Step 5

Using figure 16, check to ensure the maximum process pressure and temperature do not exceed the pressure-temperature rating of the selected bellows.

Table 15. Fisher GX Constructions with Bellows Availability

VALVE BODY SIZES	PORT SIZE (mm)	ACTUATOR SIZES	PLUG TRAVEL	TRIM STYLE
DN15-50 (NPS 1/2 to 2)	4.8 to 46	225 and 750	20 mm	Unbalanced
DN80 (NPS 3)	36 to 46	750	20 mm	Unbalanced
	70	750	20 mm	Balanced
DN100 (NPS 4)	46	750	20 mm	Unbalanced
	90	750	20 mm	Balanced

Table 16. Bellows Materials of Construction

Valve Body / Bonnet	Bellows	Bellows Stem Extension	Trim Materials		Bolting	ENVIRO-SEAL Packing	Gaskets	Lower Bushing	Monitoring Connection Plug
			Plug ⁽¹⁾	Stem Material					
Carbon Steel (1.0619/WCC and LCC)	SST (1.4571/316Ti)	S31603	S31603 or CF3M	S31603	SA193-B7 with NCF2 coating	Live-loaded PTFE	Graphite laminate	S31600 with R31233 insert	S31600
	N10276	S31603	S31603 or CF3M	S31603	SA193-B7 with NCF2 coating	Live-loaded PTFE	Graphite laminate	S31600 with R31233 insert	S31600
	N10276	N06022	N06022 or CW2M	N06022	S20910	Live-loaded PTFE	Graphite laminate	N10276 with R31233 insert	N10276
Stainless Steel (1.4409/CF3M)	SST (1.4571/316Ti)	S31603	S31603 or CF3M	S31603	S20910	Live-loaded PTFE	Graphite laminate	S31600 with R31233 insert	S31600
	N10276	S31603	S31603 or CF3M	S31603	S20910	Live-loaded PTFE	Graphite laminate	S31600 with R31233 insert	S31600
	N10276	N06022	N06022 or CW2M	N06022	S20910	Live-loaded PTFE	Graphite laminate	N10276 with R31233 insert	N10276
CW2M	N10276	N06022	N06022 or CW2M	N06022	S20910	Live-loaded PTFE	Graphite laminate	N10276 with R31233 insert	N10276

1. Plug material for the 4.8 mm port is R31233.

For bellows height dimensions, see table 21.

Cycle Life

Bellows service life is affected by several factors, including process pressure, temperature, and plug travel. Tables 17, 18, 19, and 20 provide estimates of cycle life for several cases.

Table 17. Estimated Bellows Cycle Life at 10.3 bar (150 psig) and 20°C (68°F)

VALVE SIZE	STEM SIZE	BELLOWS MATERIAL	PLYS	BELLOWS PRESSURE	PROCESS TEMPERATURE		ESTIMATED CYCLE LIFE (50% Stroke [25-75% travel])
					°C	°F	
DN15-50 (NPS 1/2 to 2)	10mm	1.4571 (316Ti)	2	10.3 bar (150 psig)	20	68	1,040,000
		N10276	3	10.3 bar (150 psig)	20	68	910,000
DN80-100 (NPS 3 to 4)	14mm	1.4571 (316Ti)	2	10.3 bar (150 psig)	20	68	1,020,000
		N10276	2	10.3 bar (150 psig)	20	68	980,000

Table 18. Estimated Bellows Cycle Life at Bellows Maximum Allowable Pressure and 20°C (68°F)

VALVE SIZE	STEM SIZE	BELLOWS MATERIAL	PLYS	MAXIMUM ALLOWABLE BELLOWS PRESSURE ⁽¹⁾	PROCESS TEMPERATURE		ESTIMATED CYCLE LIFE (50% Stroke [25-75% travel])
					°C	°F	
DN15-50 (NPS 1/2 to 2)	10mm	1.4571 (316Ti)	2	40 bar (580 psig)	20	68	830,000
		N10276	3	51.7 bar (750 psig)	20	68	800,000
DN80-100 (NPS 3 to 4)	14mm	1.4571 (316Ti)	2	45 bar (650 psig)	20	68	800,000
		N10276	2	51.7 bar (750 psig)	20	68	810,000

1. Valve maximum allowable pressure drop may be limited by size and material. See [GX bulletin 51.1:GX\(S1\)](#) for additional information.

Table 19. Estimated Bellows Cycle Life at Bellows Maximum Allowable Pressure and 232°C (450°F)

VALVE SIZE	STEM SIZE	BELLOWS MATERIAL	PLYS	MAXIMUM ALLOWABLE BELLOWS PRESSURE ⁽¹⁾	PROCESS TEMPERATURE		ESTIMATED CYCLE LIFE (50% Stroke [25-75% travel])
					°C	°F	
DN15-50 (NPS 1/2 to 2)	10mm	1.4571 (316Ti)	2	29.8 bar (430 psig)	232	450	410,000
		N10276	3	47.2 bar (685 psig)	232	450	560,000
DN80-100 (NPS 3 to 4)	14mm	1.4571 (316Ti)	2	33.5 bar (485 psig)	232	450	390,000
		N10276	2	47.2 bar (685 psig)	232	450	550,000

1. Valve maximum allowable pressure drop may be limited by size and material. See [GX bulletin 51.1:GX\(S1\)](#) for additional information.

Table 20. Estimated Bellows Cycle Life at Bellows Maximum Allowable Pressure and 371°C (700°F)

VALVE SIZE	STEM SIZE	BELLOWS MATERIAL	PLYS	MAXIMUM ALLOWABLE BELLOWS PRESSURE	PROCESS TEMPERATURE		ESTIMATED CYCLE LIFE (50% Stroke [25-75% travel])
					°C	°F	
DN15-50 (NPS 1/2 to 2)	10mm	1.4571 (316Ti)	2	26.1 bar (380 psig)	371	700	250,000
		N10276	3	39.3 bar (570 psig)	371	700	430,000
DN80-100 (NPS 3 to 4)	14mm	1.4571 (316Ti)	2	29.3 bar (425 psig)	371	700	240,000
		N10276	2	39.3 bar (570 psig)	371	700	430,000

Bellows Pressure - Temperature Ratings

See figure 16.

Figure 16. Bellows Pressure - Temperature Ratings

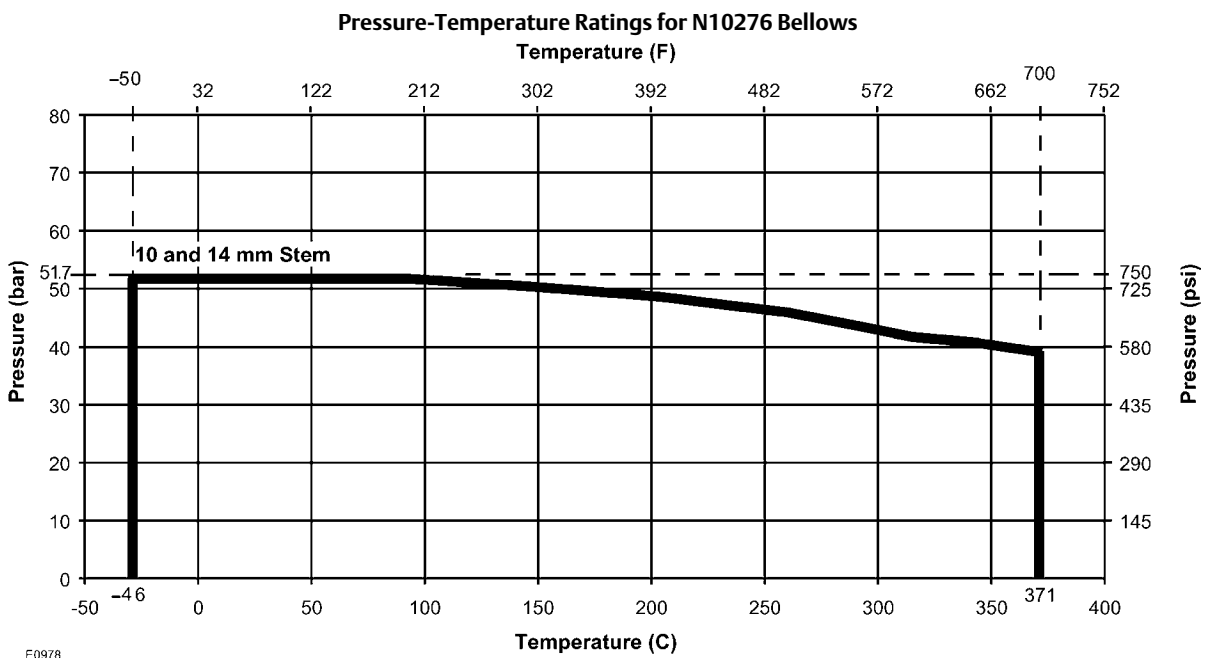
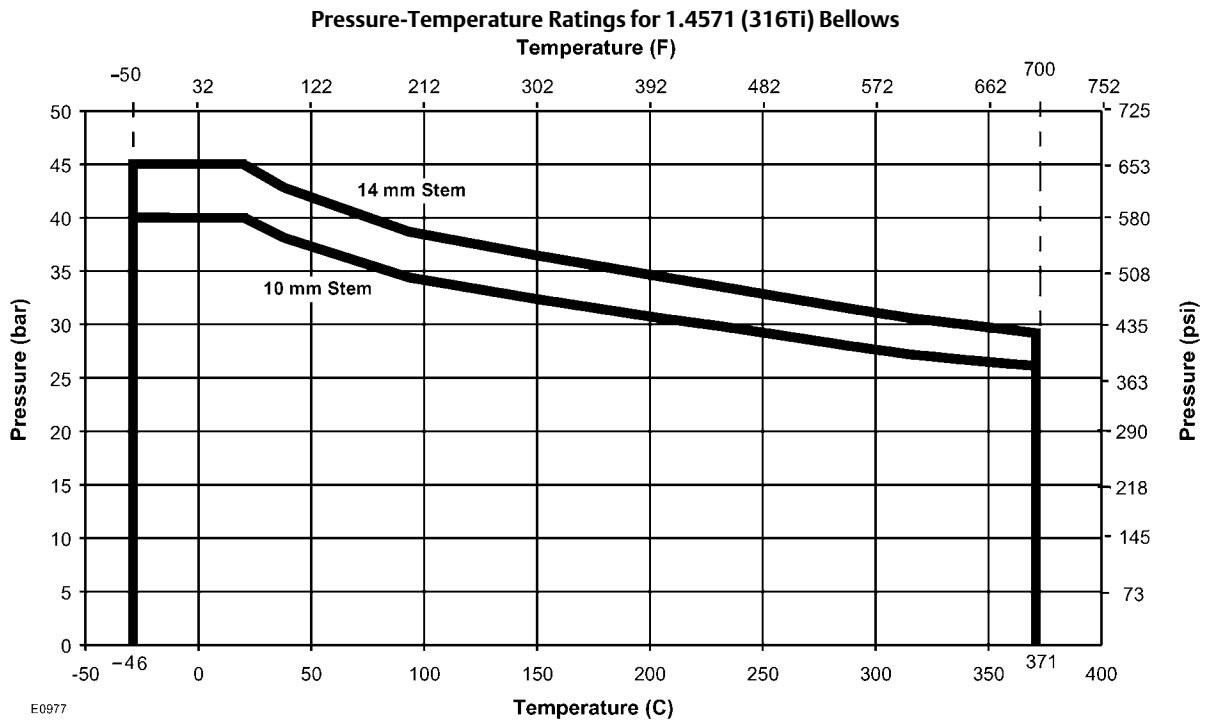

Valve-Actuator Dimensions and Weights

See figure 17 and table 21.

Figure 17. Fisher GX Dimensions (also see table 21)

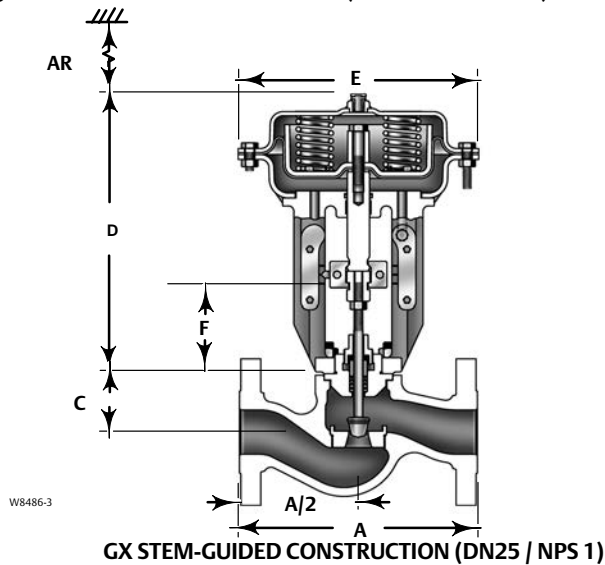
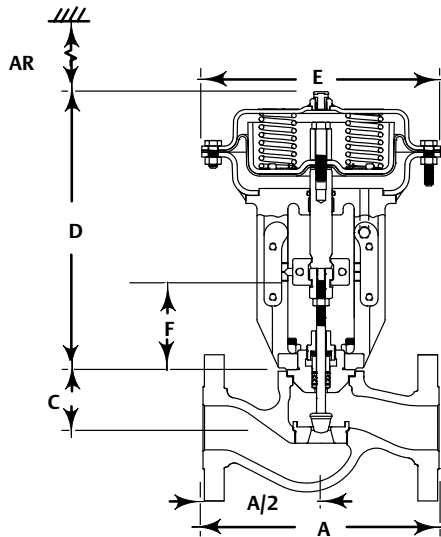

Table 21. Fisher GX Dimensions and Weights

VALVE SIZE	PORT DIA	ACTUATOR SIZE	A			C		D		E Casing Dia	F (AR) Removal Height ⁽³⁾	TOTAL WEIGHT	
			PN10/ 16 & PN25/ 40	CL150	CL300	Standard Bonnet	Extended or Bellows Bonnet	Actuator Height (Standard Bonnet)	Actuator Height (Extended or Bellows Bonnet)			With Standard Bonnet	With Extended or Bellows Bonnet
			mm	mm	mm	mm	mm	mm	mm			kg	kg
DN 15/ NPS 1/2	4.8, 9.5	225	130	184	190	66	304	313	313	270	115	21	25
DN 20/ NPS 3/4	4.8, 9.5, 14	225	150	184	194	66	304	313	313	270	115	22	26
DN 25/ NPS 1	4.8, 9.5, 14, 22	225	160	184	197	58	296	313	313	270	115	22	26
DN 40/ NPS 1-1/2	14, 22, 36	225	200	222	235	62	300	313	313	270	115	25	29
	36	750	200	222	235	62	300	342	342	430	115	52	56
DN 50/ NPS 2	22, 36, 46	225	230	254	267	68	306	313	313	270	115	29	33
	36, 46	750	230	254	267	68	306	342	342	430	115	56	60
DN 80/ NPS 3	36, 46	750	310	298	318	105	373	375	375	430	125	79	88
	70 ⁽¹⁾	750	310	298	318	105	373 ⁽⁴⁾	375	375	430	125	81	90
	70	750	310	298	318	105	373	395	395	430	125	83	92
DN 100/ NPS 4	46	750	350	352	368	121	393	379	375	430	130	98	109
	70	750	350	352	368	121	393	399	395	430	130	101	111
	90 ⁽²⁾	750	350	352	368	121	393 ⁽⁴⁾	379	375	430	130	105	115
	90 ⁽¹⁾	750	350	352	368	121	393	399	395	430	130	101	111
DN 150/ NPS 6	136	1200	480	451	473	189	---	559	---	566	224	235	---
	136 ⁽¹⁾	1200	480	451	473	200	---	559	---	566	210	247	---
	136 ⁽⁵⁾	1200	480	451	473	230	---	589	---	566	240	247	---

1. Balanced trim design.
 2. Balanced trim with reduced-capacity plug.
 3. Clearance required for removing actuator from installed valve body.
 4. Bellows bonnets are available for these constructions. However, extension bonnets are not available with balanced trim due to temperature limitations of the trim seals.
 5. Severe service.

Figure 18. Fisher GX Long Face-to-Face Dimensions (also see table 22)



GE03755_A_3

Table 22. Fisher GX Long Face-to-Face Dimensions and Weights

VALVE SIZE	PORT DIA	ACTUATOR SIZE	A		C		D		E Casing Dia	F (AR) Removal Height ⁽¹⁾	TOTAL WEIGHT	
			Long CL150	Long CL300	Std Bonnet	Extension or Bellows Bonnet	Actuator Height (Standard Bonnet)	Actuator Height (Extension or Bellows Bonnet)			With Standard Bonnet	With Extension or Bellows Bonnet
			mm	mm	mm	mm	mm	mm			kg	kg
DN 25/ NPS 1	4.8	225	216	216	58	296	313	313	270	115	22	26
	9.5	225	216	216	58	296	313	313	270	115	22	26
	14	225	216	216	58	296	313	313	270	115	22	26
	22	225	216	216	58	296	313	313	270	115	22	26
DN 40/ NPS 1-1/2	14	225	241.3	241.3	62	300	313	313	270	115	25	29
	22	225	241.3	241.3	62	300	313	313	270	115	25	29
	36	750	241.3	241.3	62	300	342	342	430	115	52	56
DN 50/ NPS 2	22	225	292.1	292.1	68	306	313	313	270	115	30	34
	36	750	292.1	292.1	68	306	342	342	430	115	57	61
	46	750	292.1	292.1	68	306	342	342	430	115	57	61

1. Clearance required for removing actuator from installed valve body.

Figure 19. Fisher GX Electric Actuator Mounting Dimensions (also see table 23)

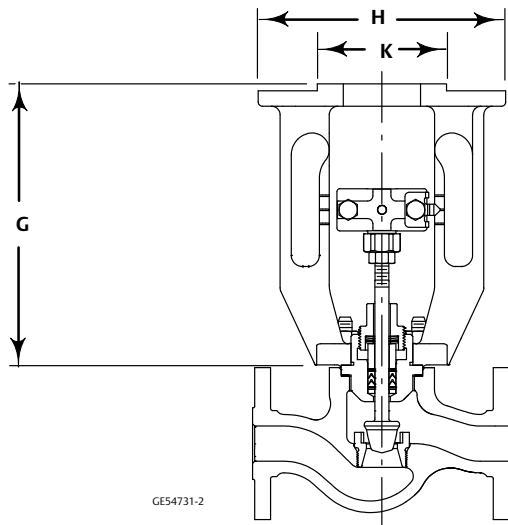

GE54731-2

GX ELECTRIC ACTUATOR MOUNTING

Table 23. Fisher GX Electric Actuator Mounting Dimensions and Weights

VALVE SIZE	PORT DIAMETER	G	H	K	GX ELECTRIC ACTUATOR MOUNTING WEIGHT	
					With Standard Bonnet	With Extension or Bellow Bonnet
	mm	mm	mm	mm	kg	kg
DN 15/ NPS 1/2	4.8, 9.5	202	170	92	12	16
DN 20/ NPS 3/4	4.8, 9.5, 14	202	170	92	13	17
DN 25/ NPS 1	4.8, 9.5, 14, 22	202	170	92	13	17
DN 40/ NPS 1-1/2	14, 22, 36	202	170	92	16	20
	36				15	19
DN 50/ NPS 2	22, 36, 46	202	170	92	20	24
	36, 46				19	23
DN 80/ NPS 3	36, 46	222	170	92	42	51
	70 ⁽¹⁾				44	53
	70				43	52
DN 100/ NPS 4	46	226	170	92	61	72
	70				61	71
	90 ⁽²⁾				65	75
	90 ⁽¹⁾				64	74
90						

1. Balanced trim design.
2. Balanced trim with reduced-capacity plug.
3. Severe service.

Table 24. Positioner Selection Guidelines

Type	Digital I/P(1)	I/P(2)	P/P(3)	Intrinsic Safety(4)	Flameproof / Explosionproof(4)	Non- Incendive(4)
DVC2000	X			X		X
DVC6200	X			X	X	X
3661		X		X		X
3660			X			

1. Digital I/P - microprocessor based electro-pneumatic with HART communication.
 2. I/P - electro-pneumatic
 3. P/P - pneumatic
 4. Refer to Fisher bulletin 9.2:001 ([D103222X012](#)) for instrument hazardous area classification details.

Fisher GX Actuator Accessories

The GX is available with a variety of pneumatic (P/P), electro-pneumatic (I/P), and digital valve positioners, as well as limit switches and solenoids. Table 24 provides the basic features of the positioners offered with the GX actuator.

The Fisher FIELDVUE DVC2000 Digital Valve Controller

The DVC2000 digital valve controller (figure 20) is simple to use, compact, and designed for the GX control valve. It converts a 4-20mA input signal into a pneumatic output signal, which feeds the control valve actuator. Instrument setup is performed with a pushbutton and LCD interface. This interface is protected from the environment within an IP66 enclosure. Multiple languages are supported with the local interface including German, French, Italian, Spanish, Chinese, Japanese, Portuguese, Russian, Polish, Czech, Arabic, and English. Additionally, HART® communication is supported over the 4-20mA loop wiring.

The DVC2000 is designed to be integrally mounted to the GX actuator, avoiding the need for mounting brackets. The DVC2000 mounts directly to an interface pad on the actuator yoke leg with a secure 3-point mounting. An internal passage inside the yoke leg transmits the pneumatic signal to the actuator casing, eliminating the need for external tubing (in the air-to-open configuration).

Figure 20. Fisher FIELDVUE DVC2000 Digital Valve Controller



The high-performance linkage-less position feedback system eliminates physical contact between the valve stem and the digital valve controller or instrument. There are no wearing parts so cycle life is maximized. Additionally, the elimination of levers and linkages reduces the number of mounting parts and the mounting complexity. Digital valve controller or instrument replacement and maintenance is simplified because the feedback parts stay connected to the actuator.

The DVC2000 is available with an optional module which includes two (2) integral limit switches and a stem position transmitter. The limit switches are configurable for open and closed valve indication. The position transmitter provides a 4-20mA signal for valve position feedback verification. As an integral component to the instrument, this option module avoids the need for difficult-to-mount external switches and transmitters.

Designed to meet intrinsic safety and non-incendive requirements, this instrument delivers scalable functionality and high performance in a small package.

Optional Positioners and Instruments

Fisher FIELDVUE DVC6200 Digital Valve Controller

The DVC6200 digital valve controller is a communicating, microprocessor-based current-to-pneumatic instrument. Using HART or FOUNDATION™ fieldbus communication protocol, access to critical instrument, valve, and process conditions is provided. When used with ValveLink™ software, valve diagnostic tests can be run while the valve is in service to advise you of the performance of the entire control valve assembly. Designed to meet a broad range of hazardous area classifications, this instrument offers maximum functionality to improve your process performance. (See figure 21 and table 24.)

Fisher 3660 and 3661 Valve Positioners

The 3660 pneumatic and 3661 electro-pneumatic positioners are rugged, accurate, and feature low steady-state air consumption. Designed to meet intrinsic safety requirements, these positioners offer simple functionality in a small package. (See figure 22 and table 24.)

Figure 21. Fisher FIELDVUE DVC6200 Digital Valve Controller



W9713

Figure 22. Fisher GX Valve with 3660 or 3661 Positioner, NAMUR Mounting (IEC 60534-6-1)



W8590

Manual Handwheels

The GX is available with an optional, side-mounted manual handwheel (see figure 23). These handwheels provide a robust method of manually operating the valve in an emergency or upon loss of instrument air.

The GX handwheel will stroke the valve up to 20mm travel, and is available on the size 225 and 750

actuators. Dimensions are provided in figure 24 and table 25.

When mounted to a fail-up actuator, rotating the handwheel clockwise moves the stem downward. When mounted to a fail-down actuator, turning the handwheel in the clockwise direction causes the stem to move upward. Disengagement of the handwheel to allow automatic operation is accomplished by turning the handwheel in the counter-clockwise direction.

Figure 23. Fisher GX Control Valve and Actuator System with Manual Handwheel

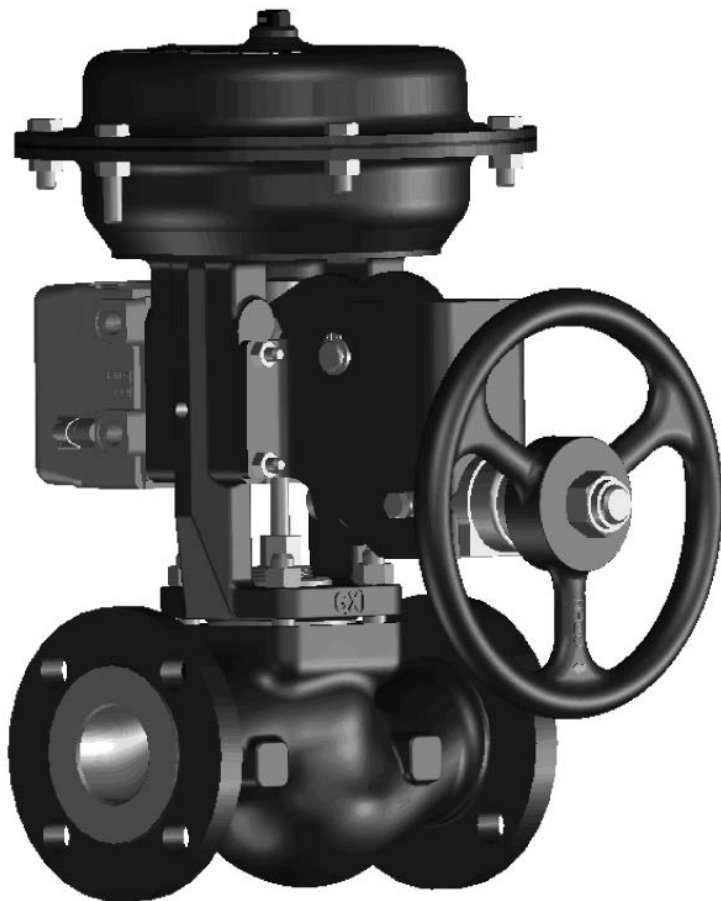

W9025

Product Bulletin

51.1:GX
August 2017

GX Control Valve and Actuator

D103171X012

Figure 24. Fisher GX with Handwheel Dimensions (also see table 25)

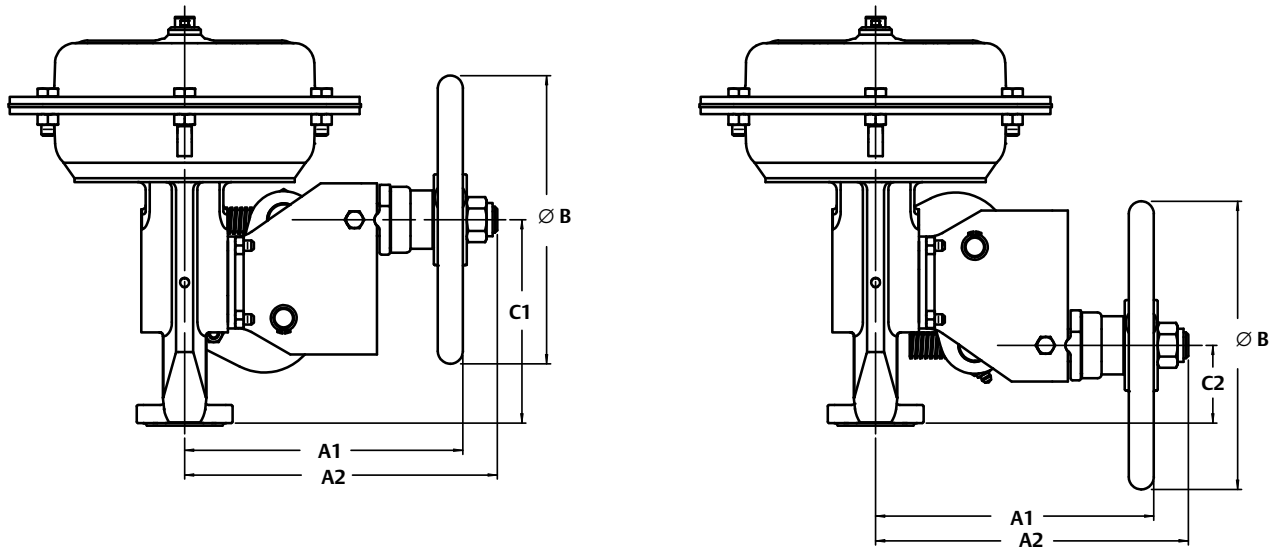

E0975

Table 25. Fisher GX with Handwheel Dimensions and Weights

VALVE SIZE		ACTUATOR SIZE	VALVE TRAVEL	HANDWHEEL WEIGHT	A1	A2	B	C1(1)	C2(2)
EN	ASME NPS								
			mm	kg	mm	mm	mm	mm	mm
DN 15	1/2	225	20	5.6	215	242	223	159	60
DN 20	3/4	225	20	5.6	215	242	223	159	60
DN 25	1	225	20	5.6	215	242	223	159	60
DN 40	1-1/2	225	20	5.6	215	242	223	159	60
		750	20	12.2	293	317	356	159	60
DN 50	2	225	20	5.6	215	242	223	159	60
		750	20	12.2	293	317	356	159	60
DN 80	3	750	20	12.2	293	317	356	169	70
DN 100	4	750	20	12.2	293	317	356	173	74
DN 150	6	1200	Contact your Emerson sales office for information.						

1. C1 is fail-down.
2. C2 is fail-up.

Neither Emerson, Emerson Automation Solutions, nor any of their affiliated entities assumes responsibility for the selection, use or maintenance of any product. Responsibility for proper selection, use, and maintenance of any product remains solely with the purchaser and end user.

Fisher, FIELDVUE, ENVIRO-SEAL, Cavitrol, ValveLink, and Whisper Trim are marks owned by one of the companies in the Emerson Automation Solutions business unit of Emerson Electric Co. Emerson Automation Solutions, Emerson, and the Emerson logo are trademarks and service marks of Emerson Electric Co. All other marks are the property of their respective owners.

The contents of this publication are presented for informational purposes only, and while every effort has been made to ensure their accuracy, they are not to be construed as warranties or guarantees, express or implied, regarding the products or services described herein or their use or applicability. All sales are governed by our terms and conditions, which are available upon request. We reserve the right to modify or improve the designs or specifications of such products at any time without notice.

Emerson Automation Solutions
Marshalltown, Iowa 50158 USA
Sorocaba, 18087 Brazil
Cernay, 68700 France
Dubai, United Arab Emirates
Singapore 128461 Singapore

www.Fisher.com

