

**OPTIONAL FIELD WIRING**  
(REFERENCE ONLY - NOT SUPPLIED)

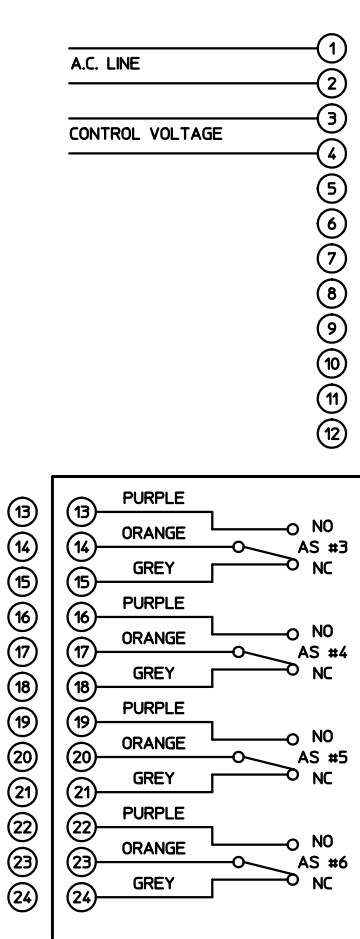

**ACTUATOR WIRING**

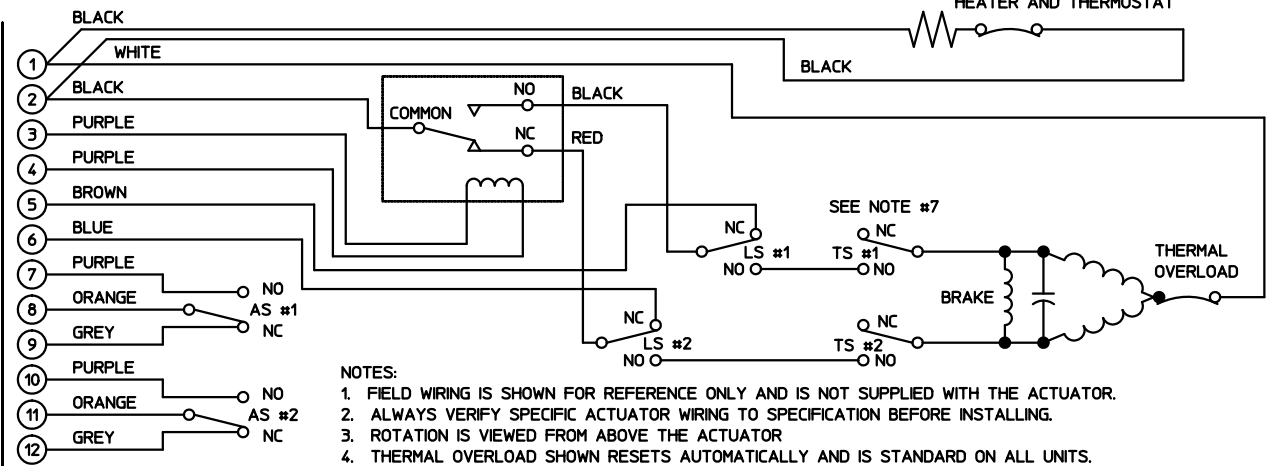

**NOTES:**

1. FIELD WIRING IS SHOWN FOR REFERENCE ONLY AND IS NOT SUPPLIED WITH THE ACTUATOR.
2. ALWAYS VERIFY SPECIFIC ACTUATOR WIRING TO SPECIFICATION BEFORE INSTALLING.
3. ROTATION IS VIEWED FROM ABOVE THE ACTUATOR
4. THERMAL OVERLOAD SHOWN RESETS AUTOMATICALLY AND IS STANDARD ON ALL UNITS.
5. SWITCHES ARE CONFIGURED FROM BOTTOM TO TOP (i.e. SWITCH 1 IS ON THE BOTTOM, SWITCH 2 IS THE NEXT ONE UP, etc.). LIMIT SWITCHES ARE ALWAYS MOUNTED BELOW AUXILIARY SWITCHES.
6. AS DEFINES AUXILIARY SWITCH. AS 1 THROUGH 6 ARE OPTIONAL AND ARE SUPPLIED ONLY IF ORDERED WITH THE ACTUATOR OR AS A KIT.
7. TS #1 AND TS #2 ARE TORQUE SWITCHES AND ARE PROVIDED ONLY ON THE 800 SERIES ACTUATORS.
8. TERMINALS 13-24 WILL BE SUPPLIED ONLY WHEN REQUIRED.
9. CAUTION: ELECTRICAL OPERATION OF THE ACTUATOR MUST BE MADE THROUGH AN INDIVIDUAL SINGLE POLE CONTROL SWITCH IN ORDER TO ISOLATE THE UNUSED MOTOR WINDINGS.
10. LS DEFINES LIMIT SWITCH OR END OF TRAVEL SWITCH.
11. ELECTRICAL BRAKE, HEATER, AND THERMOSTAT ARE OPTIONAL ON SOME EQUIPMENT. CONSULT FACTORY LITERATURE FOR AVAILABLE OPTIONS.
12. THE 200 SERIES ACTUATOR HAS A 6 POLE TERMINAL BLOCK ONLY. THEREFORE, ALL WIRING LISTED FOR TERMINALS 7 AND GREATER ARE PIGTAILED FOR THIS SERIES.



Electric Division, Mansfield, Ohio

**REVERSIBLE, 2 POSITION**  
**ACv/1Ph, 2 WIRE, RELAY CONTROL**

REVISIONS

THIS DOCUMENT IS THE PROPERTY OF BETTIS AND MAY NOT BE USED, REPRODUCED, PUBLISHED, OR DISCLOSED TO OTHERS WITHOUT EXPRESS AUTHORIZATION OF BETTIS

SCALE NONE	JOB NO	FILE	DRAWING NO.
DATE 10/28/98			WD-0012
DR. BY DK			
APPD BY TG	ASSY	REV. 1 □ 2 □ 3 □ 4 □ 5 □ 6 □	
APPD BY		NO. 7 □ 8 □ 9 □ 10 □	