

1.5 to 5 Ton ZPS*K4 and ZPS*K5 Copeland Scroll UltraTech™ Compressors



TABLE OF CONTENTS

<u>Section</u>	<u>Page</u>	<u>Section</u>	<u>Page</u>
Safety		Assembly Line Procedures	
Safety Instructions.....	2	High Potential (Hipot) Testing.....	7
Safety Icon Explanation	2	Service Procedures	
Instructions Pertaining to Risk of Electrical		Unloader Test Procedure with 24 Volts	7
Shock, Fire, or Injury to Persons.....	3	Unloader Test Procedure with Comfort Alert™ or	
Safety Statements.....	3	CoreSense™	7
Introduction		Replacing ZPS*K4 with ZPS*K5 in Service	
How It Works.....	4	Applications	8
Capacity Control.....	4	Figures	
Nomenclature.....	4	ZPS*K4 Modulation Hardware	4
Application Considerations		ZPS*K5 Modulation Hardware	4
Operating Envelope	5	Operating Envelope	9
High Pressure Cut-Out Switch	5	24 Volt Modulation Control Wiring.....	10
Low Pressure Cut-Out Switch	5	Modulation Control Wiring with Comfort Alert	10
Discharge Line Thermostat.....	5	Modulation Control Wiring with CoreSense	11
Crankcase Heat	5	Discharge Thermostat.....	11
Defrost Cycle – ZPS*K4 Applications.....	5	Crankcase Heater Location.....	12
Transient Sound Solution	6	Tables	
Unloader Solenoid Wiring	6	Condensing Temperature Limits	12
Wiring with 24 Volts.....	6	Compressor Refrigerant Charge Limits.....	12
Wiring with Comfort Alert™	6	Solenoid Resistance Values.....	12
Wiring with CoreSense™ Diagnostics	6	Compressor Accessories	13
Part-Load Starting	7		
Application Tests	7		





Safety Instructions

Copeland Scroll™ compressors are manufactured according to the latest U.S. and European Safety Standards. Particular emphasis has been placed on the user's safety. Safety icons are explained below and safety instructions applicable to the products in this bulletin are grouped on Page 3. These instructions should be retained throughout the lifetime of the compressor. **You are strongly advised to follow these safety instructions.**

Safety Icon Explanation

 DANGER	DANGER indicates a hazardous situation which, if not avoided, will result in death or serious injury.
 WARNING	WARNING indicates a hazardous situation which, if not avoided, could result in death or serious injury.
 CAUTION	CAUTION, used with the safety alert symbol, indicates a hazardous situation which, if not avoided, could result in minor or moderate injury.
NOTICE	NOTICE is used to address practices not related to personal injury.
CAUTION	CAUTION, without the safety alert symbol, is used to address practices not related to personal injury.

Instructions Pertaining to Risk of Electrical Shock, Fire, or Injury to Persons

	<p>ELECTRICAL SHOCK HAZARD</p> <ul style="list-style-type: none"> • Disconnect and lock out power before servicing. • Discharge all capacitors before servicing. • Use compressor with grounded system only. • Molded electrical plug must be used in all ZPS*K5 applications. • Refer to original equipment wiring diagrams. • Electrical connections must be made by qualified electrical personnel. • Failure to follow these warnings could result in serious personal injury.
	<p>PRESSURIZED SYSTEM HAZARD</p> <ul style="list-style-type: none"> • System contains refrigerant and oil under pressure. • Remove refrigerant from both the high and low compressor side before removing compressor. • Use appropriate back up wrenches on rotalock fittings when servicing. • Never install a system and leave it unattended when it has no charge, a holding charge, or with the service valves closed without electrically locking out the system. • Use only approved refrigerants and refrigeration oils. • Personal safety equipment must be used. • Failure to follow these warnings could result in serious personal injury.
	<p>BURN HAZARD</p> <ul style="list-style-type: none"> • Do not touch the compressor until it has cooled down. • Ensure that materials and wiring do not touch high temperature areas of the compressor. • Use caution when brazing system components. • Personal safety equipment must be used. • Failure to follow these warnings could result in serious personal injury or property damage.
	<p>COMPRESSOR HANDLING</p> <ul style="list-style-type: none"> • Use the appropriate lifting devices to move compressors. • Personal safety equipment must be used. • Failure to follow these warnings could result in personal injury or property damage.

Safety Statements

- Refrigerant compressors must be employed only for their intended use.
- Only qualified and authorized HVAC or refrigeration personnel are permitted to install, commission and maintain this equipment.
- Electrical connections must be made by qualified electrical personnel.
- All valid standards and codes for installing, servicing, and maintaining electrical and refrigeration equipment must be observed.

Introduction

The ZPS*K4 and ZPS*K5 two step modulated Copeland Scroll™ compressors are ideally suited for residential and light commercial applications where a capacity step reduction and part load efficiency are important. The ZPS*K4 is based upon the very successful ZP*K3 fixed capacity scrolls. The ZPS*K5 compressor family is the second generation of Copeland Scroll UltraTech™. The ZPS*K5 is based on the field proven, fixed capacity ZP*K5 product family and has improved part load and full load performance versus the first generation of Copeland Scroll UltraTech, ZPS*K4.

How It Works

A 24 volt DC solenoid valve inside the compressor provides the means to modulate the compressor. When the solenoid valve is energized the compressor is in full-load and when de-energized the compressor is in part-load. When the solenoid is energized in the ZPS*K4 compressor, a modulation ring moves and closes the modulation ports on the fixed scroll. When the ZPS*K5 solenoid is energized a 3-way solenoid valve provides pressure to a lift ring assembly that is used to open and close the scroll modulation ports.

A single-speed motor continues to run while the scroll modulates between the two capacity steps. Please see **Figures 1 and 2**, which show ZPS*K4 and ZPS*K5 hardware differences respectively.

Capacity Control

The compression process of a scroll compressor is described in **AE4-1331, Figure 9**. At any point in the compression process, there are several pockets within the scroll that are compressing gas. Modulation is achieved by venting a portion of the gas in the first suction pocket back to the low side of the compressor thereby reducing the effective displacement of the compressor. Full capacity is achieved by blocking these ports, thus increasing the displacement to 100%. When the solenoid is energized the compressor is in full-load or 100% of its capacity. When the solenoid is de-energized the compressor is in part-load or approximately 67% of its full load capacity. The loading and unloading of the two step scroll is done “on the fly” without shutting off the motor between steps. The unloaded mode default was chosen for two reasons:

1. It is expected that the majority of run hours will be in the low capacity, unloaded mode.
2. It allows a simple two-stage thermostat to control capacity through the second stage in both cooling and heating.

Nomenclature

The model numbers of the Copeland Scroll UltraTech compressors include the approximate nominal 60 Hz capacity at AHRI operating conditions of 45°F (7.2°C) evaporating temperature and 130°F (54.4°C) condensing temperature. An example would be the ZPS49K5E-PFV which has 49,100 Btu/hr (14.4 kW)

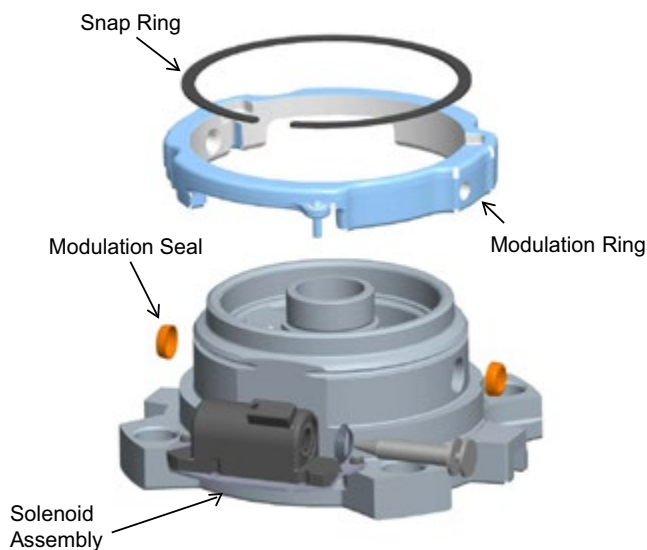

Figure 1 – ZPS*K4

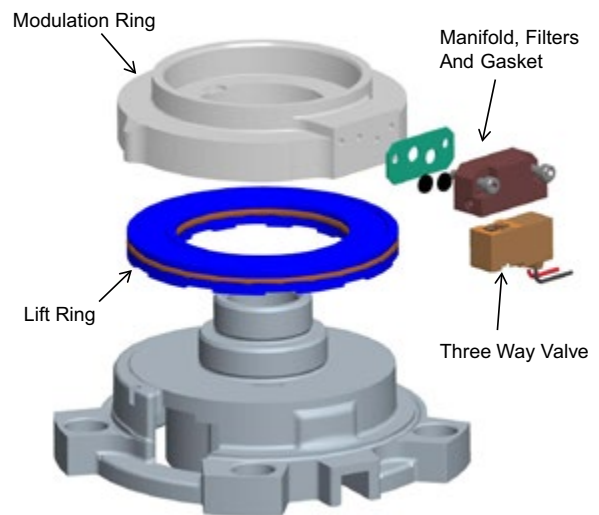

Figure 2 – ZPS*K5

at the above mentioned full load condition. Both full and part load performance data are published throughout the entire operating envelope and can be found in the Online Product Information (OPI) at www.EmersonClimate.com.

APPLICATION CONSIDERATIONS

In most respects the two step modulated scroll will operate like a standard scroll in both the high and low capacity mode. The basic application guidelines in **AE4-1331** should be adhered to for ZPS*K5 compressors, and bulletins **AE4-1331** and **AE4-1365** for ZPS*K4 compressors.

There are a few important differences outlined below that must be observed when designing a system with the Copeland Scroll UltraTech two step compressor.

Operating Envelope

The maximum operating condensing pressure varies for the ZPS*K4 compressors. Please see **Figure 3** and **Table 1** for condensing pressure limits. The maximum condensing limit is the point where the compressor can still run with a low supply voltage of 197 for the -PFV (208-230 volt) and -10% for all other motors. The ZPS compressors can operate at both full and part-load capacity throughout the entire specified operating envelope shown in **Figure 3**. The envelope represents safe operating conditions with 20F° (11K) superheat in the return gas.

High Pressure Control

A high-pressure cut-out is not required for UltraTech applications, but recommended for the highest level of system reliability.

If a high-pressure cut-out control is used the maximum setting should not exceed 650 psig (45 bar). The high pressure cut-out control should have a manual reset for the highest level of system protection. **It is not recommended to use the compressor to test the high pressure switch function during the unit assembly line run test.**

Low Pressure Control

NOTICE

A low pressure cut-out control is required on all ZPS*K4 applications. A low pressure cut-out is recommended on all ZPS*K5 applications for the highest level of system reliability. The low pressure cut-

out should be set no lower than 20 psig (1.4 bar) for heat pumps and 55 psig (3.8 bar) for air-conditioning units.

Discharge Line Thermostat

CAUTION

Compressor top cap temperatures can be very hot. Care must be taken to ensure that wiring or other materials which could be damaged by these temperatures do not come into contact with these potentially hot areas.

A discharge line thermostat is recommended for all air-source heat pump ZPS*K4 applications because those compressors do not have internal discharge temperature protection. The maximum allowable discharge temperature is 275°F (135°C). Mount the discharge thermostat as close as possible to the compressor discharge fitting and insulate well. See **Table 4** for recommended Emerson part numbers. ZPS*K5 compressors have Therm-O-Disc™ technology that will help protect the compressor during high discharge gas temperature conditions. Therefore, a discharge line thermostat is not required for ZPS*K5 applications.

Crankcase Heat

A crankcase heater is recommended on single-phase compressors when the system charge is over the charge limit shown in **Table 2**. A crankcase heater is required for systems containing more than 120% of the compressor refrigerant charge limit listed in **Table 2**. This includes long line length systems where the extra charge will increase the standard factory charge above the 120% limit.

A crankcase heater is required for three-phase compressors when the system charge exceeds the compressor charge limit listed in **Table 2**. Available crankcase heaters are listed in **Table 4**. Refer to **Figure 7** for proper installation of the crankcase heater.

WARNING! Crankcase heaters must be properly grounded.

Defrost Cycle – ZPS*K4 Applications

During a defrost cycle, when the reversing valve abruptly changes the refrigerant flow direction the suction and discharge pressures will go outside of the normal operating envelope. During this transition the scrolls will be unloaded as the system transitions from heating to

cooling and then from cooling back to heating. The sound that the compressor makes during this transition period is normal and the duration of the sound will depend on the coil volume, outdoor ambient temperature, and system charge. The preferred method of mitigating defrost sound is to shut down the compressor for 20 to 30 seconds when the reversing valve changes position going into and coming out of the defrost cycle. This technique allows the system pressures to reach equilibrium without the compressor running.

CAUTION Reversing valve sizing must be within the guidelines of the valve manufacturer. Required pressure drop to ensure valve shifting must be measured throughout the operating range of the unit and compared to the valve manufacturer's data. Low ambient heating conditions with low flow rates and low pressure drop across the valve can result in a valve not shifting. This can result in a condition where the compressor appears to be not pumping (i.e. balanced pressures). It can also result in elevated compressor sound levels.

Defrosting with the compressor in full load, versus part load, will help defrost the outdoor coil in a shorter period of time and will also help the reversing valve shift positions during low outdoor ambient temperatures when flow conditions can be low.

Transient Sound Solution

ZPS*K5 compressors built after January, 2012 (serial number 12A and later) employ the transient sound solution. The transient sound solution is a design improvement that provides improved compressor sound quality during defrost and other transient conditions. De-energizing the ZPS*K5 compressor at the beginning and end of the defrost cycle is no longer necessary to mitigate compressor defrost sound.

Unloader Solenoid Wiring

NOTICE

The current in the ZPS*K5 modulation solenoid circuit must be less than 0.9 mA for the solenoid valve to change from full-load to part-load. If the current is greater than 0.9 mA the solenoid valve can stay in full-load. A time delay relay or another current consuming load in-series with the modulation solenoid could result in current greater than 0.9 mA.

The ZPS*K5 modulation solenoids are purchased from two different suppliers and have different resistance

values (see **Table 3**). The different solenoid coils have the same functionality and will be used in compressor production at the same time. To determine which modulation solenoid is in the compressor, the resistance of the modulation circuit will have to be measured.

Standard Wiring with 24 Volts

A nominal 24-volt direct current coil activates the internal unloader solenoid in the ZPS*K4 and ZPS*K5 compressors. The input control circuit voltage must be 18 to 28 volt AC or DC. The maximum solenoid VA is 20 and 5 for the ZPS*K4 and ZPS*K5 respectively. The external solenoid electrical connection is made with a molded plug assembly, see **Table 4** for the appropriate part number. This plug contains a full wave rectifier to supply direct current to the unloader coil if the control circuit is AC. If the control circuit is DC, the same plug with the full wave rectifier can be used as the full wave rectifier will have no effect on the DC voltage input. When a DC power source is used, the polarity of the DC input to the plug isn't critical. The rectified molded plug can be sourced from some of the same suppliers of the molded electrical plug used to power the compressor motor. A simple wiring diagram is show in **Figure 4**.

Wired with Comfort Alert™

Please read **Forms No. 2006ECT-54** and **2005ECT-191** to understand the functioning of this module. Comfort Alert is a diagnostic tool that is installed separately in the electrical box of the unit. It monitors and analyzes the status of the scroll compressor and detects and communicates any system or compressor problems without using external sensors that would have to be installed into the system. Any faults are translated through a blinking LED that can guide the technician quickly and accurately to the root cause of a problem. A simple wiring diagram with Comfort Alert is shown in **Figure 5**.

In addition to diagnostics, Comfort Alert provides application benefits when used with Copeland Scroll UltraTech. A few of those benefits that are related to the modulation aspect of UltraTech include:

1. A solenoid power saving feature for ZPS*K4 compressors where the solenoid VA load is reduced from 20 to 6VA.
2. Comfort Alert ensures part-load starting by delaying the Y2 signal to the solenoid for 5 seconds after start-up. This is a definite starting

advantage under low voltage conditions.

3. If the internal overload trips in the compressor the Comfort Alert will de-energize the solenoid, preventing an overheat condition of the solenoid coil.
4. The full wave rectifier circuit is incorporated into Comfort Alert, allowing a lower cost molded plug without the full wave rectifier.

Wired with CoreSense™ Diagnostics

CoreSense for UltraTech provides both diagnostics and active protection, in addition to the modulation features offered by Comfort Alert. Please read **AE8-1379** for more information on CoreSense Diagnostics for UltraTech. A simple wiring diagram for CoreSense is shown in **Figure 6**.

Table 4 lists Comfort Alert, CoreSense and molded plug part numbers for various types of applications.

Part-Load Starting

There are a number of benefits associated with starting the UltraTech compressors in part-load. Improved starting is realized during a low voltage and/or flooded start condition whereby stress on the motor, scrolls, and 3-way modulation valve is significantly reduced. Starting in part-load can result in the compressor starting and accelerating to full speed faster, thereby reducing the perception of light dimming. Part-load starting also reduces the inrush current on the 24 volt transformer.

For the highest level of system reliability, part-load starting is recommended for for all ZPS*K4 & ZPS*K5 UltraTech compressors.

APPLICATION TESTS

Refer to the **Application Tests** section of **AE4-1331** for the application tests to run to help ensure a reliable application. Consult with your Emerson Climate Technologies Application Engineer if interpretation of application test results is required.

ASSEMBLY LINE PROCEDURES

Hipot (AC High Potential) Testing



Use caution with high voltage and never hipot when compressor is in a vacuum.

If the 24 volt modulation solenoid circuit is dielectric (hipot) strength tested, the maximum applied voltage should not exceed 1,000 volts RMS for 1 second at 2.0mA maximum leakage current.

Refer to the **Assembly Line Procedures** section of **AE4-1331** for additional guidelines to follow for OEM assembly line processes.

SERVICE PROCEDURES



Use caution when troubleshooting energized circuits.

Unloader Test Procedure with Standard 24 Volt Wiring

If it is suspected that the unloader is not working, the following methods may be used to verify operation.

1. Operate the system and measure compressor amperage. Cycle the unloader on and off at ten second intervals. An increase in compressor amperage should be observed when switching from part-load to full-load and a reduction in compressor amperage should be observed when changing from full-load to part load. The percent change in current depends on the operating conditions and voltage.
2. **Step 2 applies to ZPS*K4 compressors only. For ZPS*K5 compressors proceed to Step 3.** If Step 1 does not give the expected results shut unit off. Apply 18 to 28 VAC to the unloader molded plug leads and listen for a click as the solenoid pulls in. Remove power and listen for another click as the unloader returns to its original position. If clicks can't be heard, proceed to Step 3. If clicks can be heard, put the unit back into operation and repeat Step 1.
3. Shut off power and remove the control circuit molded plug from the compressor and measure the unloader solenoid coil resistance. The solenoid coil should have continuity and not be grounded or have infinite resistance. If the coil resistance is infinite, zero, or grounded, the compressor must be replaced. See **Table 3** for modulation solenoid resistance values.
4. Check the molded plug.
Voltage check: Apply control voltage to the plug wires (18 to 28 VAC). The measured DC voltage

at the connectors in the plug should be around 15 to 27 VDC.

Resistance check: Measure the resistance from the end of one molded plug lead to either of the two female connectors in the plug. One of the connectors should read close to zero ohms while the other should read infinity. Repeat with other wire. The same female connector as before should read zero while the other connector again reads infinity. Reverse polarity on the ohmmeter leads and repeat. The female connector that read infinity previously should now read close to zero ohms.

Replace plug if either of these test methods doesn't show the desired results.

Unloader Test Procedure with Comfort Alert or CoreSense

If it is suspected that the unloader is not working, the following methods may be used to verify operation.

1. Operate the system and measure compressor amperage. Cycle the unloader on and off at ten second intervals by applying and removing Y2 voltage to the module. Wait five seconds after power is applied to Y2 before taking a reading. An increase in compressor amperage should be observed when switching from part-load to full-load and a reduction in compressor amperage should be observed when changing from full-load to part load. The percent change in current depends on the operating conditions and voltage.
2. If Step 1 does not give the expected results remove the solenoid plug from the compressor and with the unit running and the thermostat calling for Y2 to be energized test the voltage output at the plug with a dc voltmeter. The reading should be 4 to 18 VDC for Comfort Alert and 18 to 28 VDC for CoreSense (see **Table 4** for Comfort Alert and CoreSense part numbers). If not, unplug the harness from the module and check voltage at the "DC Sol" pins of the module. The module will not power the unloader solenoid if the compressor is not running or Fault Code 1 or 9 is active.
3. If the correct DC voltage is at the control circuit molded plug measure the unloader coil resistance. The solenoid coil should have continuity and not be grounded or have infinite resistance. If the coil resistance is infinite, zero, or grounded, the compressor must be replaced.

Replacing ZPS*K4 with ZPS*K5 in Service Applications

ZPS*K5 compressors will be used to replace ZPS*K4 in service applications when the ZPS*K4 compressor family is phased out of production in 2013. ZPS*K5 compressors have the same mounting configuration and approximately the same tube location as the K4 compressors.

Special consideration needs to be given to the compressor contactor since some ZPS*K5 compressors have higher RLA and LRA values than the ZPS*K4 compressor that is being replaced. In some cases the system contactor may need to be upsized. The run capacitor may need to be changed to match the specification called for by the new ZPS*K5 compressor. The allowable tolerance on run capacitors is +5 to -0 microfarads. If the ZPS*K4 compressor being replaced has a start capacitor and relay for light dimming effects, the replacement compressor must have a new start capacitor and relay of the correct ratings or no start kit at all. For more information on compressor electrical data please refer to the **Online Product Information** at **EmersonClimate.com**.

Modulation plug part number 529-0138-01 will be shipped with the service compressor to help keep the residual current in the modulation circuit to less than 0.9 mA. This modulation plug has the molex plug that is needed to plug directly into the Comfort Alert, CoreSense, or White-Rodgers Unitary Control Board. If the system doesn't have one of these controls, cut the molex plug off and connect the individual wires to the appropriate termination points per the system wiring diagram.

For more information on service practices refer to **Service Procedures** in **AE4-1331**.

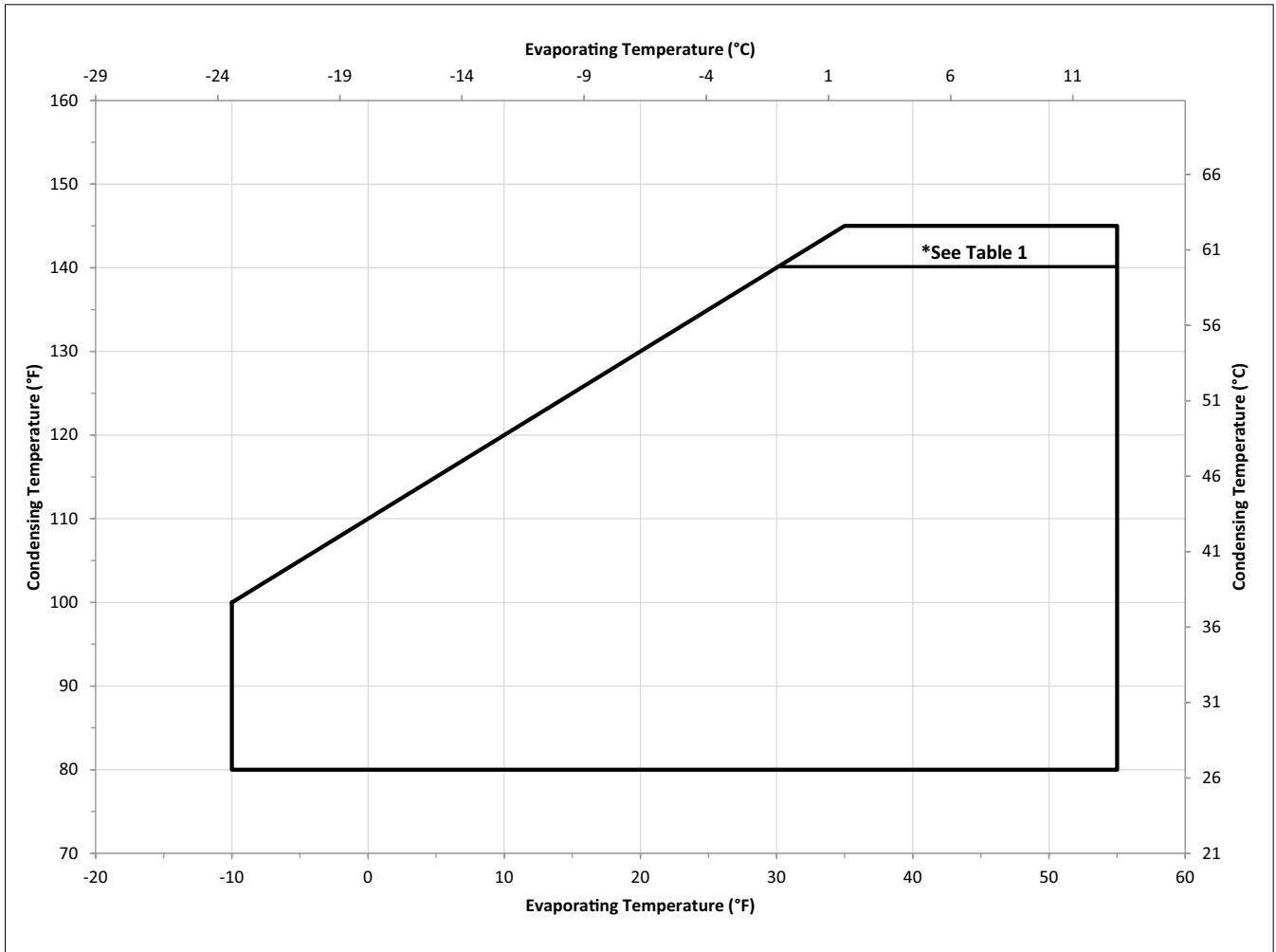

Figure 3
Operating Envelope

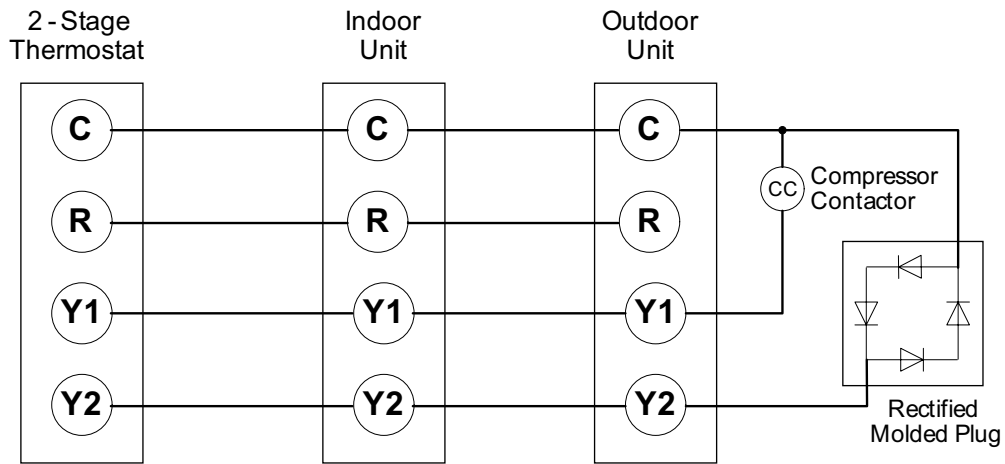

Figure 4
Example of 24 Volt Modulation Control Wiring

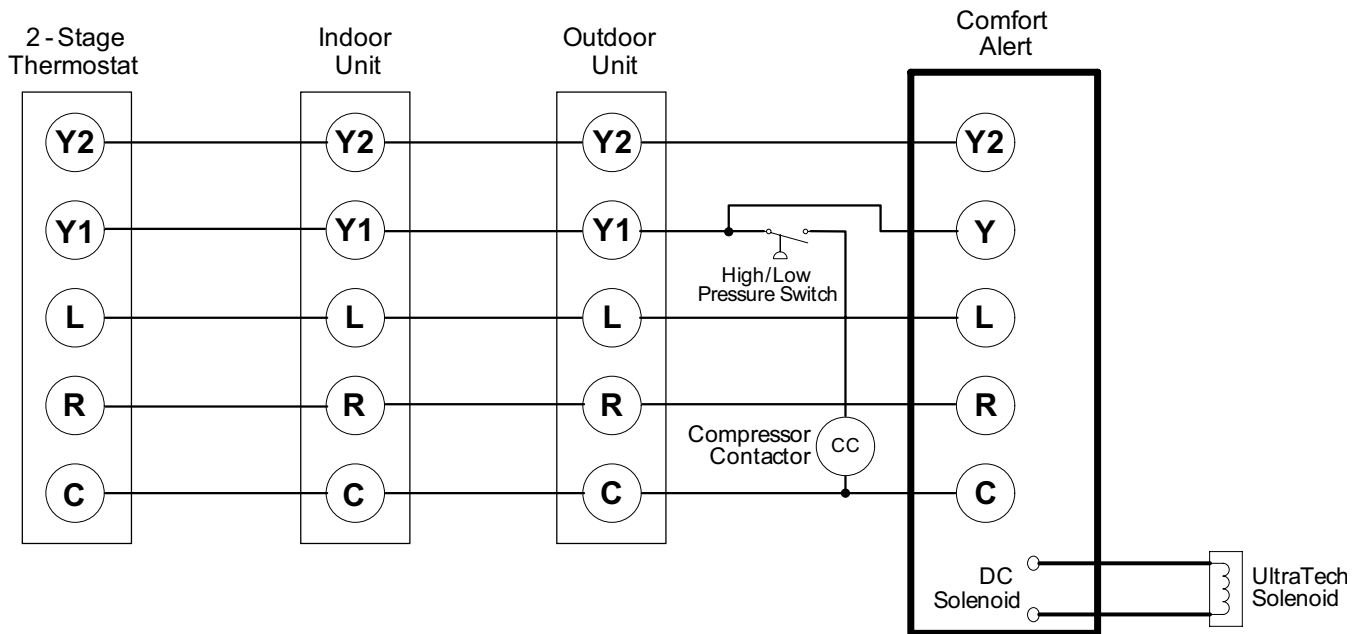

Figure 5
Example of Modulation Control Wiring With Comfort Alert

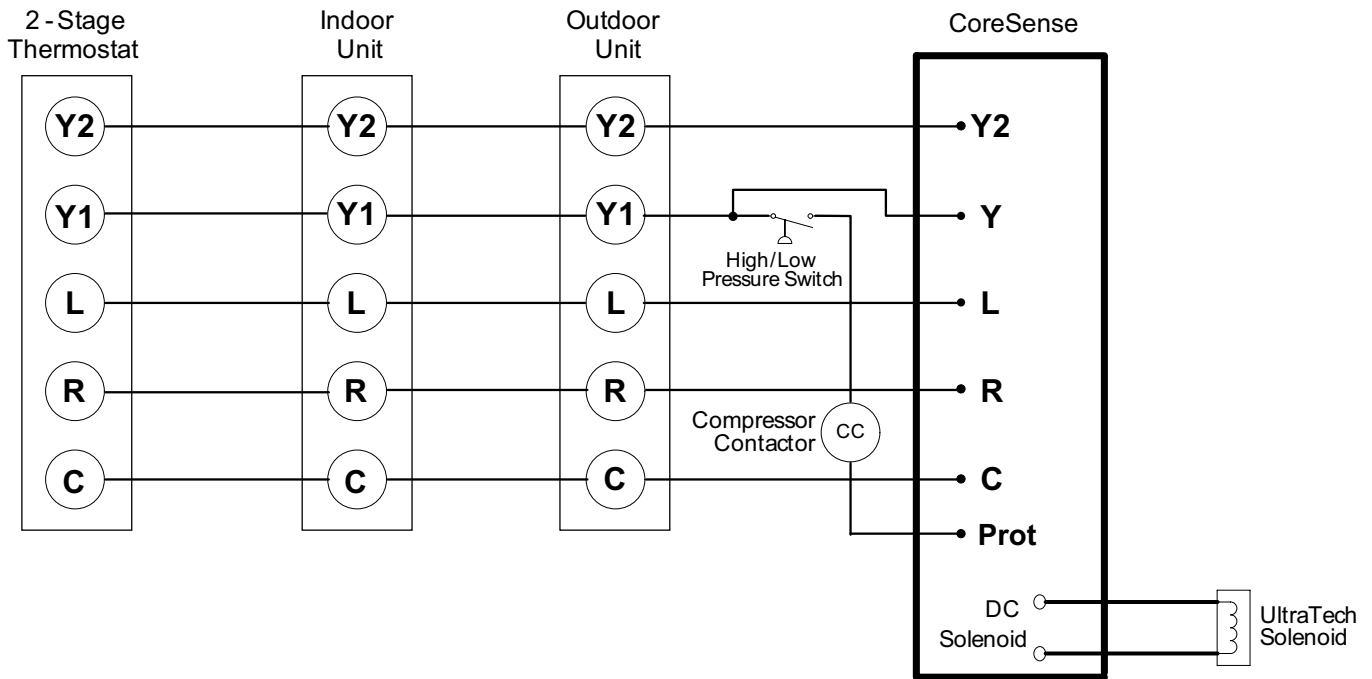
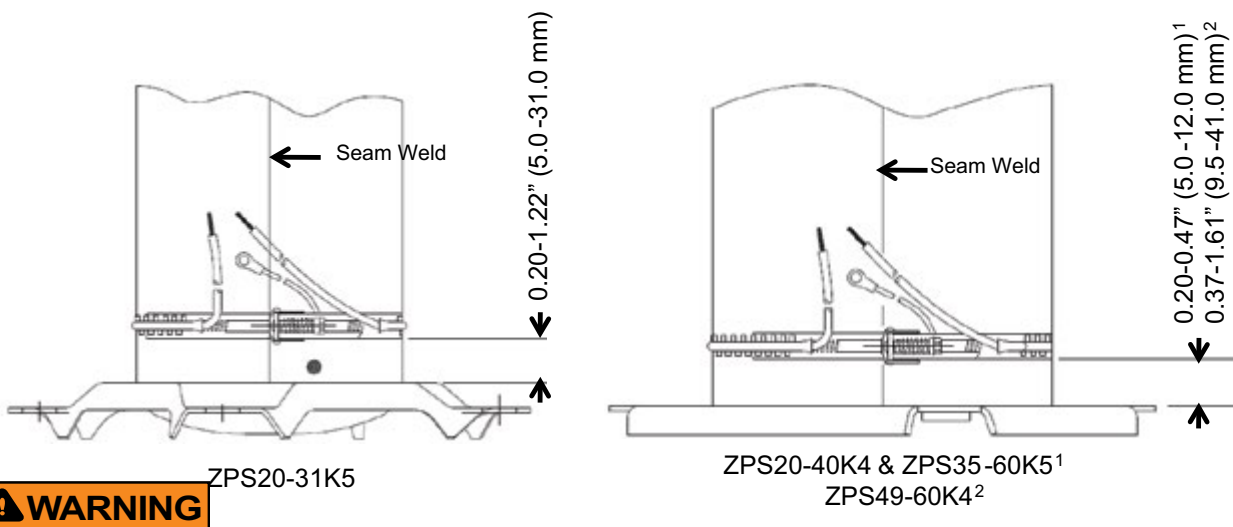

Figure 6
Example of Modulation Control Wiring With CoreSense

Connect the heater so that the connection point straddles the compressor seam weld



Verify the correct crankcase heater voltage for the application and ensure heater is properly grounded.

Figure 7 – Crankcase Heater Location

Table 1

Model	Max Condensing Temp
ZPS20,30,40,49,51K4	140°F/60°C
ZPS26,35,60K4	145°F/63°C
All ZPS*K5	145°F/63°C

Table 2 - Compressor Refrigerant Charge Limits

Model	Frame Size*	Charge Limit		120% x Limit**	
		Pounds	kg	Pounds	kg
ZPS20 - 31K5	53	8	3.6	9.6	4.3
ZPS35 - 60K5	63	10	4.5	12.0	5.4
ZPS20 - 40K4	63	10	4.5	12.0	5.4
ZPS49 - 60K4	70	10	4.5	12.0	5.4

*Approximate Shell Diameter (e.g. 63 = 6.5 Inches)

**Charge Allowance For System

Table 3 – Solenoid Resistance Values

Compressor Family	Compressor Models	Solenoid Resistance	
ZPS*K4	All Models	33.6 Ω	
ZPS*K5	All Models	Source "A"	1640 Ω
		Source "B"	350 Ω

Table 4 – Compressor Accessories

Part Category	Part Description	Part Number	Models	Notes
Mounting	Compressor Mounting Kit	527-0044-15	ZPS20-31K5	30-35 Durometer
	Compressor Mounting Kit	527-0116-00	ZPS20-60K4 ZPS35-60K5	35-45 Durometer
Crankcase Heater	Crankcase Heater, 120V, 40W	018-0094-01	ZPS20-31K5	21" Leads
	Crankcase Heater, 240V, 40W	018-0094-00		21" Leads
	Crankcase Heater, 480V, 40W	018-0094-03		21" Leads
	Crankcase Heater, 575V, 40W	018-0094-04		21" Leads
	Crankcase Heater, 120V, 40W	018-0096-01	ZPS20-40K4 ZPS35-60K5	21" Leads
	Crankcase Heater, 240V, 40W	018-0096-00		21" Leads
	Crankcase Heater, 480V, 40W	018-0096-02		21" Leads
	Crankcase Heater, 575V, 40W	018-0096-03		21" Leads
	Crankcase Heater, 240V, 40W	018-0096-04	ZPS49-60K4	48" Leads
	Crankcase Heater, 480V, 40W	018-0096-05		48" Leads
	Crankcase Heater, 120V, 70W	018-0095-07		48" Leads
	Crankcase Heater, 240V, 70W	018-0095-04		48" Leads
	Crankcase Heater, 480V, 70W	018-0095-05	48" Leads	
	Crankcase Heater, 575V, 70W	018-0095-06	48" Leads	
	Crankcase Heater Junction Box	998-7024-00	ZPS35-60K4	
Crankcase Heater Junction Box	998-7026-00	ZPS20-30K4 ZPS35-60K5		
Electrical	Terminal Cover & Gasket	505-0564-00	ZPS20-40K4	
	Terminal Cover & Gasket	505-0867-00	ZPS49-60K4	
	Flag Terminal Kit	998-0021-00	ZPS20-60K4	
	Grounding Screw	100-0605-00	All Models	10-32 x 8mm Long, Taptite Screw
	Molded Plug	529-0370-00	All Models	Universal Plug, 10 Gauge, 42" Leads
	Molded Plug Retainer Clip	032-0717-00	All Models	Locks the Molded Plug to Fence
	Flexible Metal Conduit Retainer	032-7051-01	All Models	Molded Plug-Conduit Retainer
	Modulation Plug	529-0061-00	All Models	Rectified Plug, OEM Use with ZPSK4 & ZPSK5
	Modulation Plug	529-0062-00	All Models	OEM Use with CoreSense/Comfort Alert and ZPSK4 & ZPSK5
	Modulation Plug	529-0138-01	All Models	OEM & Service, Universal Plug for All Applications
	Run Capacitor	Refer To Online Product Information at www.EmersonClimate.com for Model Specific Requirements		
	Start Capacitor			
Start Relay				
Diagnostics & Protection	SecureStart™	943-0120-00	ZPS20-40K5 ZPS51K5 ZPS20-60K4	1-Phase Only
	CoreSense™ Diagnostics Module	571-0072-00	All Models	1-Phase Applications
	Comfort Alert™ Module	543-0033-01	All Models	1-Phase AC & HP, No Power Saving
	Comfort Alert™ Module	543-0124-00	All Models	1-Phase WSHP, No Power Saving
Suction & Discharge	Comfort Alert™ Module	543-0122-00	All Models	3-Phase, No Power Saving
	Discharge Line Thermostat	998-7022-02	All Models	Conduit Ready, Fits 1/2" Tube
	Discharge Rotalock O-Ring Seal	020-0028-00	All Models	
	Suction Rotalock O-Ring Seal	020-0028-02	All Models	
	Rotalock Service Valve, Disc 1/2"	998-0510-98	All Models	
	Rotalock Service Valve, Suct 3/4"	998-0510-38	ZPS20-31K5 ZPS20-40K4	
	Rotalock Service Valve, Suct 7/8"	998-0510-90	ZPS35-60K5 ZPS49-60K4	
	Disc Rotalock Adapter to 1/2" Sweat	998-0034-18	All Models	
	Suct Rotalock Adapter to 3/4" Sweat	998-0034-07	ZPS20-31K5 ZPS20-40K4	
	Suct Rotalock Adapter to 7/8" Sweat	998-0034-08	ZPS35-60K5 ZPS49-60K4	
	1/2" Disc Stub Adapter to 1"-14 Rotalock	036-0538-00	All Models	Requires 020-0028-00 Seal
	3/4" Suct Stub Adapter to 1-1/4"-12 Rotalock	998-0034-01	ZPS20-31K5 ZPS20-40K4	
7/8" Suct Stub Adapter to 1-1/4"-12 Rotalock	998-0034-02	ZPS35-60K5 ZPS49-60K4		

The contents of this publication are presented for informational purposes only and they are not to be construed as warranties or guarantees, express or implied, regarding the products or services described herein or their use or applicability. Emerson Climate Technologies, Inc. reserves the right to modify the designs or specifications of such products at any time without notice. Emerson Climate Technologies, Inc. does not assume responsibility for the selection, use or maintenance of any product. Responsibility for proper selection, use and maintenance of any Emerson Climate Technologies, Inc. product remains solely with the purchaser and end-user.