

PmPPC7448

PMC Module

■ Embedded Computing for
Business-Critical Continuity™

PowerPC based Processor PMC

- Up to 1.4 GHz PowerPC® processor
- Up to 2GB SDRAM in SO-DIMM packaging
- Marvell Discovery III system controller
- Dual 10/100/1000 Ethernet with P14 access
- 10/100 Ethernet on front bezel
- I²C & four GPIO ports with P14 access
- Carrier Grade Linux and VxWorks board support packages
- Quality assured by over 30 years of design experience and a TL 9000 and ISO 9001:2000 certified quality management system. (FM 26789)

The Emerson Network Power PmPPC7448 PCI Mezzanine Card (PMC) module is a complete processor subsystem in a very compact, industry standard form factor. It is designed to allow communication equipment manufacturers to add modular and upgradeable functionality to their I/O baseboard. It also provides the localized horsepower necessary for applications such as protocol processing, packet processing, data filtering or I/O management.

Using an off-the-shelf processor subsystem improves your time-to-market by allowing you to focus your engineering efforts on the key value-add portions of the system without spending time and effort on the processor design and testing. A modular processor subsystem also lowers your lifetime cost of ownership by providing an easy upgrade path, and protecting you from obsolescence issues.

Considerable engineering effort has gone into ensuring maximum flexibility on the PmPPC7448. The module can be used in both Processor PMC monarch and non-monarch modes, acting as the host for the local PCI bus or as a peripheral on the local PCI bus, depending on the application or baseboard. The SDRAM memory is contained in a SO-DIMM package—the same memory package widely used in laptop computers—so you can take advantage of the rapidly advancing memory capacity.

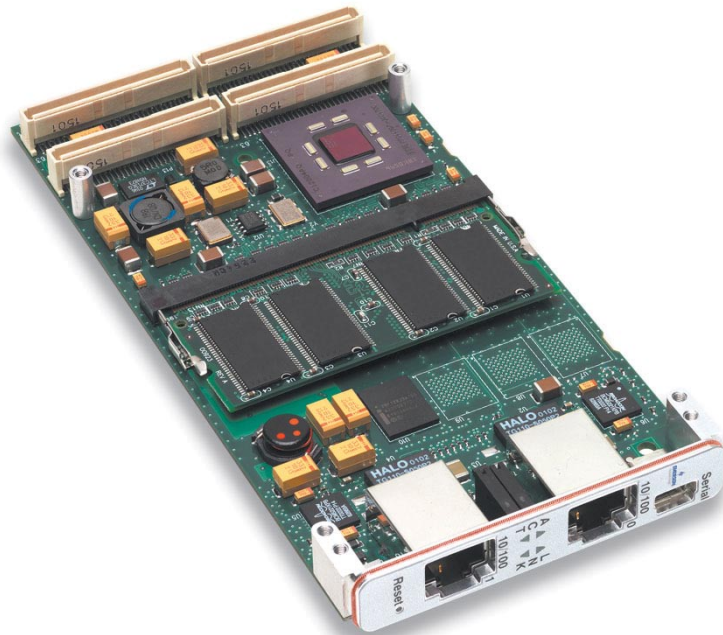

Block Diagram

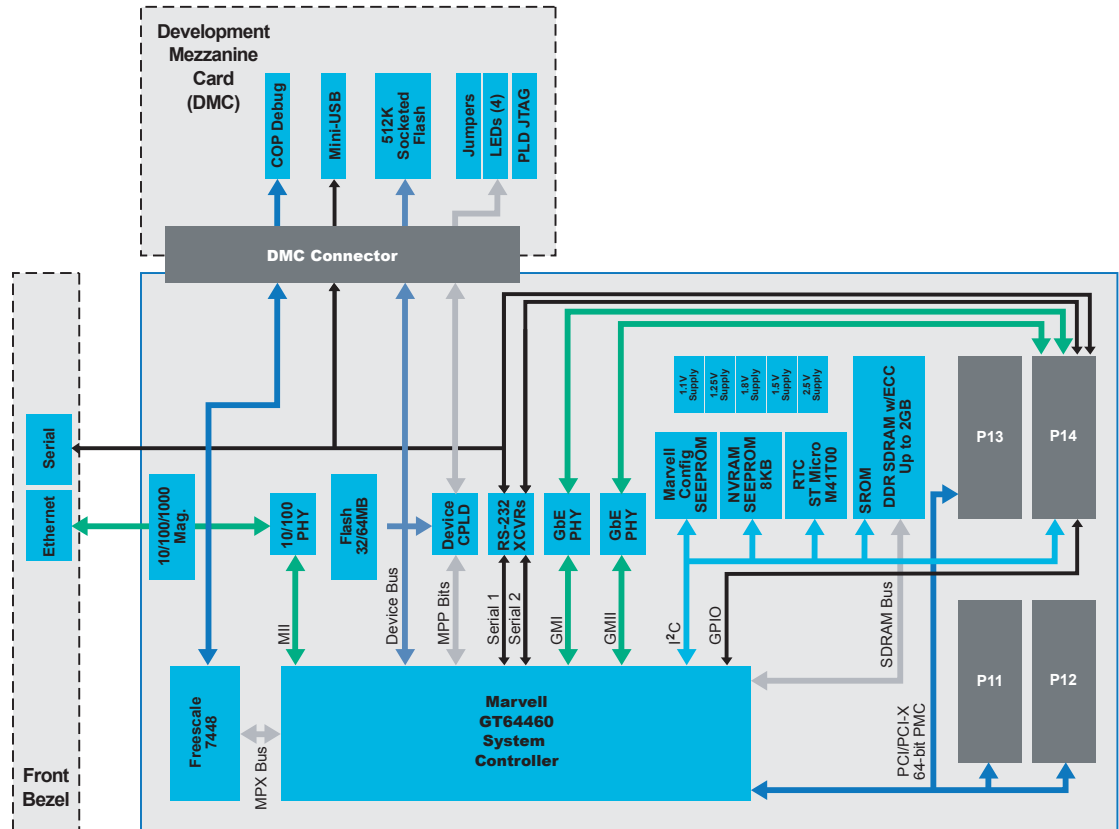

Specifications

PROCESSOR

PowerPC MPC7448 running at up to 1.4 GHz

- 32-bit address bus, 64-bit data bus
- L1 cache
 - ▲ 32K, 32-byte line, 8-way set associative instruction and data cache
 - ▲ Single-cycle cache access
- 1MB on-chip core speed L2 cache with ECC
- AltiVec vector unit
- Up to 166 MHz MPX bus

MEMORY

SDRAM

- 256MB, 512MB, 1GB or 2GB* SDRAM configurations with ECC
- Modular and upgradeable SO-DIMM packaging
- 133 MHz operation

*2GB configuration requires 15mm standoff

Flash

- 32 or 64MB flash configurations
- Flash Architecture NOR

I/O

Ethernet

- Two 10/100/1000BaseT Ethernet ports with access via P14 connector
- Single 10/100BaseTX Ethernet port with front bezel access

Serial Ports

- Two RS-232 asynchronous serial ports
- Both ports available via P14 connector
- One of the ports available via bezel or via optional Development Mezzanine Card (DMC)

I2C

- 2-wire independent bus
- Master or slave mode
- Access via P14 connector for end-user applications

General Purpose Timers

- Four 32-bit counter/timers
- 32-bit watchdog timer

Real-Time Clock

- I²C

General Purpose I/O

- Eight TTL-compatible lines on P14

JTAG/COP

- Available during development via optional DMC

Direct Memory Access (DMA)

- 4-channel DMA support
- High-speed data movement between any module resources without significant CPU intervention

PCI

- 33/66 MHz operation via Marvell Discovery system controller
- 32/64-bit data path
- Monarch and non-monarch mode support (local host or peripheral)
- PCI 2.2
- 133 MHz PCI-X v1.0

LEDs and Switches

- Four user-programmable surface mount LEDs on PMC module for development
- Recessed front panel reset switch

DEVELOPMENT MEZZANINE CARD (DMC)

- Optional plug-on card (side 2) to speed development
 - ▲ RS-232 debug serial port with cable to DB-9 connector
 - ▲ Processor JTAG/COP header for software development
 - ▲ ISP header for FPGA
 - ▲ Four user-programmable surface mount LEDs
 - ▲ Four software-readable configuration jumpers
 - ▲ 32-pin PLCC socket for software development
- Single connector to attach to PMC module

SOFTWARE SUPPORT

- Monitor with power-on self test
- Board support package for Wind River VxWorks
- Board support package for Carrier Grade Linux

PHYSICAL CHARACTERISTICS

- PMC form factor: 149 mm x 74 mm
- Power supply: 3.3Vdc*
- Power dissipation: 18W typical on selected configurations
- Operating range: 0° to 55° C, 5-95% relative humidity (non-condensing)

*The 1.3 GHz configuration includes an option for dual 3.3V and 5V supply operation

SPEC COMPLIANCE

- IEEE 1386
- VITA 32
- PCI 2.2

REGULATORY COMPLIANCE

- UL/CSA/IEC 60950
- ICES-003 (Canada)
- FCC Part 15 (US)
- EN55022
- EN 300 386
- EN55024
- Applicable sections of NEBS Telcordia GR1089 and GR63

SOLUTION SERVICES

Emerson Network Power provides a portfolio of solution services optimized to meet your needs throughout the product lifecycle. Design services help speed time-to-market. Deployment services include global 24x7 technical support. Renewal services enable product longevity and technology refresh.

PowerPC is a trademark of IBM Corp. All other trademarks are the property of their respective owners.

This document identifies products, their specifications, and their characteristics, which may be suitable for certain applications. It does not constitute an offer to sell or a commitment of present or future availability, and should not be relied upon to state the terms and conditions, including warranties and disclaimers thereof, on which Emerson Network Power may sell products. A prospective buyer should exercise its own independent judgment to confirm the suitability of the products for particular applications. Emerson Network Power reserves the right to make changes, without notice, to any products or information herein which will, in its sole discretion, improve reliability, function, or design. Emerson Network Power does not assume any liability arising out of the application or use of any product or circuit described herein; neither does it convey any license under its patent or other intellectual property rights or under others. This disclaimer extends to any prospective buyer, and it includes Emerson Network Power's licensee, licensee's transferees, and licensee's customers and users. Availability of some of the products and services described herein may be restricted in some locations.

Emerson Network Power.
The global leader in enabling
Business-Critical Continuity™.

■ AC Power Systems
■ Connectivity
■ DC Power Systems
■ **Embedded Computing**

■ Embedded Power
■ Integrated Cabinet Solutions
■ Outside Plant
■ Power Switching & Control

■ Precision Cooling
■ Services
■ Site Monitoring
■ Surge & Signal Protection

Emerson Network Power

Offices: Tempe, AZ U.S.A. 1 800 759 1107 or +1 602 438 5720 • Madison, WI U.S.A. 1 800 356 9602 or +1 608 831 5500
Shanghai, China +86 10 85631 122 • Paris, France +33 1 60 92 31 20 • Tokyo, Japan +81 3 5403 2730
Munich, Germany +49 89 9608 2333 • Hong Kong, China +852 2176 3540 • Tel Aviv, Israel +972 3 568 4387

www.EmersonNetworkPower.com/EmbeddedComputing

Emerson, Business-Critical Continuity, Emerson Network Power and the Emerson Network Power logo are trademarks and service marks of Emerson Electric Co.
©2008 Emerson Electric Co.