

PmPPC750f

PMC Module

Embedded Computing for
Business-Critical Continuity™

PowerPC based Processor PMC

- PowerPC® 750FX processor running at 733 MHz
- 128MB, 256MB, 512MB or 1GB ECC SDRAM in SO-DIMM package
- 32/64-bit 33/66 MHz PCI with DMA
- Three 10/100 Ethernet interfaces
- Processor PMC monarch and non-monarch modes
- Two serial I/O ports
- I²C interface
- Quality assured by over 30 years of design experience and a TL 9000 and ISO 9001:2000 certified quality management system. (FM 26789)

The Emerson Network Power PmPPC750f PCI Mezzanine Card (PMC) module is a complete processor subsystem in a very compact, industry standard form factor. It is designed to allow communication equipment manufacturers to add modular and upgradeable compute functionality to their I/O baseboard and provide the localized horsepower necessary for applications such as protocol processing, packet processing, data filtering or I/O management.

Using an off-the-shelf processor subsystem improves your time-to-market by allowing you to focus your engineering efforts on the key value-add portions of the system without spending time and effort on the processor design and testing. A modular processor subsystem also lowers your lifetime cost of ownership by providing an easy upgrade path, and protecting you from obsolescence issues.

Considerable engineering effort has gone into ensuring maximum flexibility on the PmPPC750f. The module can be used in both Processor PMC monarch and non-monarch modes, which means that it can act as the host (monarch) of the local PCI bus or be a peripheral (non-monarch) on the local PCI bus depending on the application or baseboard. We've also implemented the SDRAM memory using SO-DIMM packaging, the same memory package used dominantly in laptop computers.



EMERSON[™]
Network Power

Block Diagram

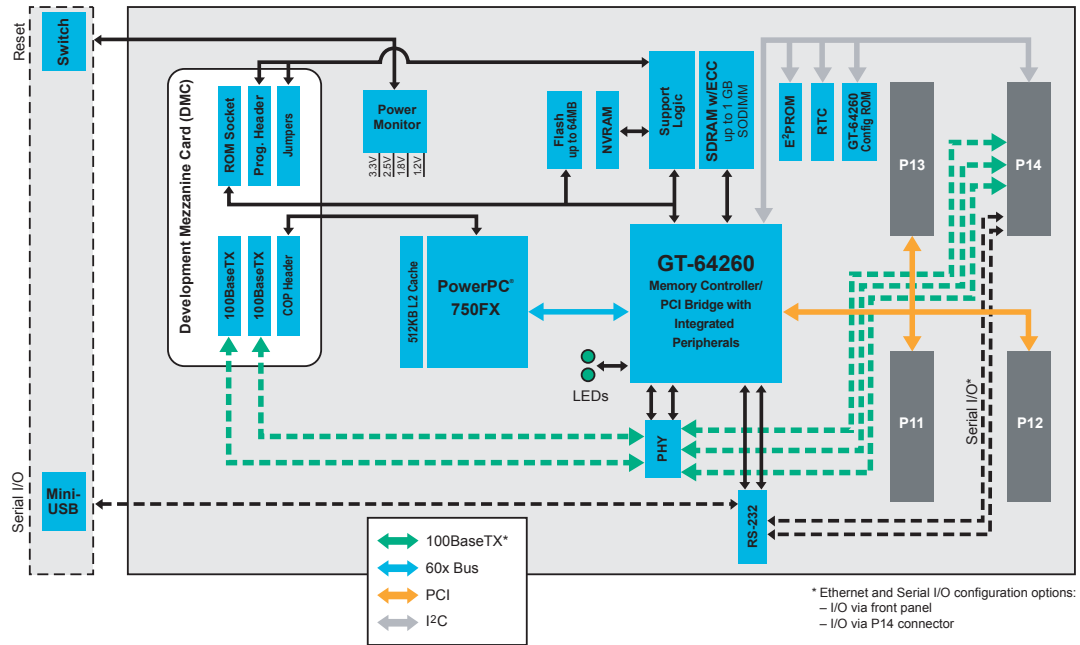

Specifications

PROCESSOR

PowerPC 750FX running at 733 MHz

- 32-bit address bus, 64-bit data bus
- L1 cache
 - ▲ 32K, 32-byte line, 8-way set associative instruction and data cache
 - ▲ Single-cycle cache access
- 512K on-chip core speed L2 cache with ECC
- Floating-Point Unit (FPU)

MEMORY

SDRAM

- 128MB, 256MB, 512MB or 1GB SDRAM configurations with ECC
- Modular and upgradable SO-DIMM packaging
- 133 MHz operation (100 MHz for 1 GB configuration)

Flash

- 16, 32 or 64MB flash configurations
- Organized as two banks – for protected field updateable image
- Flash Architecture NOR

I/O

Ethernet

- Three 10/100Base Fast Ethernet ports with access via P14 connector
- Two of the 10/100BaseTX Ethernet ports available during development via optional Development Mezzanine Card (DMC)

Serial Ports

- Two RS-232 asynchronous serial ports
- Both ports available with access via P14 connector
- One of the ports available via bezel or one of the ports available during development via optional DMC

I²C

- 2-wire independent bus
- Master or slave mode
- Access via P14 connector for end-user applications

General Purpose Timers

- Eight 32-bit counter/timers
- 32-bit watchdog timer

Real-Time Clock

- I²C

DMA

- 8-channel DMA support
- High-speed data movement between any module resources without significant CPU intervention

PCI

- 33/66 MHz operation via Marvell Discovery system controller
- 32/64-bit data path
- Monarch and non-monarch mode support (local host or peripheral)
- PCI 2.2 compliant

LEDs and Switches

- Four development user-programmable surface mount LEDs on PMC module
- Four development user-programmable surface mount LEDs on optional DMC
- Recessed front panel reset based

DEVELOPMENT MEZZANINE CARD (DMC)

- Optional plug-on card (side 2) to speed development
 - ▲ Dual 10/100BaseTX Ethernet ports via two RJ-45 connectors
 - ▲ RS-232 debug serial port with cable to DB-9 connector processor COP header for software development
 - ▲ JTAG header for PCI bridge and on-card logic
 - ▲ Four software-readable configuration jumpers
 - ▲ 32-pin PLCC socket for software development
- Single connector to attach to PMC module

SOFTWARE SUPPORT

- Monitor with power-on self test
- Board support package for VxWorks
- Board support package for Linux
- Board support package for QNX

ACCESSORIES

- DMC
- Serial cable
- User manual

PHYSICAL CHARACTERISTICS

- PMC form factor: 149 mm x 74 mm
- Power supply: 3.3Vdc
- Power dissipation: 9W typical
- Operating range: 0°–55° C, 5–95% relative humidity (non-condensing)

SPEC COMPLIANCE

- IEEE 1356.4
- VITA 32
- PCI 2.2

REGULATORY COMPLIANCE

- UL/CSA 60950
- IEC 950
- Canada ICES-003
- EN55022 FCC Part 15
- NEBS Bellcore GR1089
- NEBS Bellcore GR63
- EN 300386

SOLUTION SERVICES

Emerson Network Power provides a portfolio of solution services optimized to meet your needs throughout the product lifecycle. Design services help speed time-to-market. Deployment services include global 24x7 technical support. Renewal services enable product longevity and technology refresh.

PowerPC is a trademark of IBM Corp. All other trademarks are the property of their respective owners.

This document identifies products, their specifications, and their characteristics, which may be suitable for certain applications. It does not constitute an offer to sell or a commitment of present or future availability, and should not be relied upon to state the terms and conditions, including warranties and disclaimers thereof, on which Emerson Network Power may sell products. A prospective buyer should exercise its own independent judgment to confirm the suitability of the products for particular applications. Emerson Network Power reserves the right to make changes, without notice, to any products or information herein which will, in its sole discretion, improve reliability, function, or design. Emerson Network Power does not assume any liability arising out of the application or use of any product or circuit described herein; neither does it convey any license under its patent or other intellectual property rights or under others. This disclaimer extends to any prospective buyer, and it includes Emerson Network Power's licensee, licensee's transferees, and licensee's customers and users. Availability of some of the products and services described herein may be restricted in some locations.

Emerson Network Power.
The global leader in enabling
Business-Critical Continuity™.

■ AC Power Systems
■ Connectivity
■ DC Power Systems
■ **Embedded Computing**

■ Embedded Power
■ Integrated Cabinet Solutions
■ Outside Plant
■ Power Switching & Control

■ Precision Cooling
■ Services
■ Site Monitoring
■ Surge & Signal Protection

Emerson Network Power

Offices: Tempe, AZ U.S.A. 1 800 759 1107 or +1 602 438 5720 • Madison, WI U.S.A. 1 800 356 9602 or +1 608 831 5500
Shanghai, China +86 10 85631 122 • Paris, France +33 1 60 92 31 20 • Tokyo, Japan +81 3 5403 2730
Munich, Germany +49 89 9608 2333 • Hong Kong, China +852 2176 3540 • Tel Aviv, Israel +972 3 568 4387

www.EmersonNetworkPower.com/EmbeddedComputing

Emerson, Business-Critical Continuity, Emerson Network Power and the Emerson Network Power logo are trademarks and service marks of Emerson Electric Co.
©2008 Emerson Electric Co.