

Rosemount™ 2140 and 2140:SIS Level Detectors

Vibrating Fork



Safety messages

NOTICE

Read this manual before working with the product. For personal and system safety, and for optimum product performance, ensure you thoroughly understand the contents before installing, using, or maintaining this product.

For technical assistance, contacts are listed below:

Customer Central

Technical support, quoting, and order-related questions.

- United States - 1-800-999-9307 (7:00 am to 7:00 pm CST)
- Asia Pacific- 65 777 8211

North American Response Center

Equipment service needs.

- 1-800-654-7768 (24 hours a day — includes Canada)
- Outside of these areas, contact your local Emerson representative.

⚠ WARNING

Failure to follow safe installation and servicing guidelines could result in death or serious injury.

Ensure the level detector is installed by qualified personnel and in accordance with applicable code of practice.

Use the level detector only as specified in this manual. Failure to do so may impair the protection provided by the level detector.

The weight of a level detector with a heavy flange and extended fork length may exceed 37 lb. (18 kg). A risk assessment is required before carrying, lifting, and installing the level detector.

For installations in hazardous locations, the level detector must be installed according to the Rosemount 2140 and 2140:SIS Level Detectors [Product Certifications](#) document.

⚠ WARNING

Explosions could result in death or serious injury.

Verify that the operating atmosphere of the level detector is consistent with the appropriate hazardous locations certifications.

Before connecting a handheld communicator in an explosive atmosphere, ensure that the instruments in the loop are installed in accordance with intrinsically safe or non-incendive field wiring practices.

In explosion-proof/flameproof and non-incendive installations, do not remove the housing covers when power is applied to the level detector.

Both housing covers must be fully engaged to meet flameproof/explosion-proof requirements.

⚠ WARNING

Electrical shock could cause death or serious injury.

Avoid contact with the leads and terminals. High voltage that may be present on leads can cause electrical shock.

Ensure the power to the level detector is off, and the lines to any other external power source are disconnected or not powered while wiring the level detector.

Ensure the wiring is suitable for the electrical current and the insulation is suitable for the voltage, temperature, and environment.

⚠ WARNING

Process leaks could result in death or serious injury.

Ensure the level detector is handled carefully. If the process seal is damaged, gas might escape from the vessel (tank) or pipe.

⚠ WARNING

Any substitution of non-recognized parts may jeopardize safety. Repair (e.g. substitution of components) may also jeopardize safety and is not allowed under any circumstances.

Unauthorized changes to the product are strictly prohibited as they may unintentionally and unpredictably alter performance and jeopardize safety. Unauthorized changes that interfere with the integrity of the welds or flanges, such as making additional perforations, compromise product integrity and safety. Equipment ratings and certifications are no longer valid on any products that have been damaged or modified without the prior written permission of Emerson. Any continued use of product that has been damaged or modified without the written authorization is at the customer's sole risk and expense.

⚠ WARNING

Physical access

Unauthorized personnel may potentially cause significant damage to and/or misconfiguration of end users' equipment. This could be intentional or unintentional and needs to be protected against.

Physical security is an important part of any security program and fundamental to protecting your system. Restrict physical access by unauthorized personnel to protect end users' assets. This is true for all systems used within the facility.

⚠ CAUTION

The products described in this document are NOT designed for nuclear-qualified applications.

Using non-nuclear qualified products in applications that require nuclear-qualified hardware or products may cause inaccurate readings.

For information on Rosemount nuclear-qualified products, contact your local Emerson Sales Representative.

⚠ CAUTION

Hot surfaces

The flange and process seal may be hot at high process temperatures. Allow to cool before servicing.



Contents

Chapter 1	Introduction.....	7
	1.1 Using this manual.....	7
	1.2 NAMUR NE 53 revision.....	8
	1.3 Product certifications.....	8
	1.4 Product recycling/disposal.....	8
Chapter 2	Level detector overview.....	9
	2.1 Measurement principle.....	9
	2.2 Process characteristics.....	9
	2.3 Vessel characteristics.....	9
	2.4 Application examples.....	10
	2.5 Components of the level detector.....	11
Chapter 3	Mechanical installation.....	13
	3.1 Safety messages.....	13
	3.2 Installation considerations.....	14
	3.3 Installation procedures.....	22
	3.4 Adjust display orientation (optional).....	28
Chapter 4	Electrical installation.....	29
	4.1 Prepare the electrical connections.....	29
	4.2 Connect wiring and power up.....	32
Chapter 5	Configuration.....	37
	5.1 Safety messages.....	37
	5.2 Configuration tools.....	38
	5.3 Local Operator Interface (LOI).....	39
	5.4 Confirm correct device driver.....	40
	5.5 Confirm HART [®] revision capability.....	40
	5.6 Configure device using guided setup.....	41
	5.7 Verify the configuration.....	41
	5.8 Multidrop communication.....	43
	5.9 HART burst mode.....	44
	5.10 Security.....	45
Chapter 6	Operation.....	49
	6.1 LCD display screen messages.....	49
	6.2 Set up the LCD display.....	50
	6.3 View measurement data.....	50
	6.4 Check device status.....	51
	6.5 Partial proof testing.....	53

Chapter 7	Service and troubleshooting.....	57
	7.1 Safety messages.....	57
	7.2 Diagnostic messages.....	58
	7.3 Troubleshooting the 4-20 mA/HART Output.....	68
	7.4 Service and troubleshooting tools.....	69
	7.5 Opening the lid (cover).....	76
	7.6 Service support.....	76
Appendix A	Specifications and reference data.....	79
	A.1 General.....	79
	A.2 Functional safety.....	79
	A.3 Performance specifications.....	79
	A.4 Electrical specifications.....	80
	A.5 Environmental specifications.....	81
	A.6 Physical specifications.....	83
	A.7 Dimensional drawings.....	84
Appendix B	Configuration parameters.....	93
	B.1 Manual setup.....	93
	B.2 Alert setup.....	104
Appendix C	Local Operator Interface (LOI) menu trees.....	109
	C.1 LOI menu trees.....	109
Appendix D	Signal processing.....	111

1 Introduction

1.1 Using this manual

The sections in this manual provide detailed information on installing, operating, and maintaining the Rosemount 2140 and 2140:SIS Level Detectors.

The sections are organized as follows:

[Level detector overview](#) provides a description of the Rosemount 2140 and , and their basic principles.

[Mechanical installation](#) contains mechanical installation instructions.

[Electrical installation](#) contains electrical installation instructions.

[Configuration](#) provides instructions on configuration of the level detector.

[Operation](#) contains operation and maintenance techniques.

[Service and troubleshooting](#) provides troubleshooting techniques for the most common operating problems.

[Specifications and reference data](#) contains specifications and dimensional drawings.

[Configuration parameters](#) provides extended information about the configuration parameters.

[Local Operator Interface \(LOI\) menu trees](#) contains complete menu maps as a reference for when using the optional Local Operator Interface.

[Signal processing](#) contains a schematic overview of the signal processing.

1.2 NAMUR NE 53 revision

The Rosemount 2140 meets the NAMUR recommendation NE 53. [Table 1-1](#) provides the information necessary to ensure you have the correct device driver for your device.

Table 1-1: Identification and Compatibility According to NAMUR NE 53

Release date	Device identification		FDI, DD, and DTM identification		Release note (revision level 1 and 2) ⁽¹⁾
	NAMUR hardware revision ⁽¹⁾	NAMUR software revision ⁽¹⁾	HART® universal revision ⁽²⁾	Device revision	
January-2017	1.0.0	1.0.0	5	1	<ul style="list-style-type: none"> Initial release
			7	2	
March-2018	1.0.0	1.1.0	5	1	<ul style="list-style-type: none"> Removed customer upgrade feature Added Media Learn and Remote Proof Test to base model Updated the Partial Proof Test procedure
			7	2	

(1) NAMUR Revision is located on the device label. Differences in level 3 changes represent minor product changes as defined per NE53. Compatibility and functionality are preserved and product can be used interchangeably.

(2) HART Revision 5 and 7 can be switched in field.

Related information

[Confirm correct device driver](#)

1.3 Product certifications

See the Rosemount 2140 [Product Certifications](#) document for detailed information on the existing approvals and certifications.

1.4 Product recycling/disposal

Recycling of equipment and packaging should be taken into consideration and disposed of in accordance with local and national legislation or regulations.

2 Level detector overview

2.1 Measurement principle

The Rosemount 2140 and 2140:SIS are the world's first wired HART® level detector using Emerson's vibrating fork technology.

Using the principle of a tuning fork, a piezo-electric crystal oscillates the forks at their natural frequency. Changes to the oscillation frequency are continuously monitored by electronics as it varies depending on the liquid medium in which the forks are immersed. The denser the liquid, the lower the oscillation frequency.

Whenever a liquid medium in a vessel (tank) or pipe drains down past the forks, it causes a distinct frequency change. This change is detected by the electronics and a dry condition is indicated.

Whenever a liquid medium in a vessel (tank) or pipe rises and contacts the forks, again a distinct frequency change is detected. This time, the electronics will indicate a wet condition.

The wet and dry conditions can be transmitted digitally as a HART signal or as a discrete output using the analog output.

Related information

[Analog output](#)

[Signal processing](#)

2.2 Process characteristics

Emerson's vibrating fork technology is virtually unaffected by turbulence, foam, solids content, coating products, and liquid properties. The natural frequency (1400 Hz) of the fork avoids interference from plant vibration that may cause false detection. This allows for minimum intrusion into the tank or pipe using a short fork.

2.2.1 Liquid-to-sediment detection

The Rosemount 2140 version of the level detector features settings to detect liquid-to-sediment interface, and this works on other solids sediment types (e.g. salts). Liquids as well as wet sediments are detected. All versions of the level detector have a Media Learn function to fine-tune the switching point even if the media characteristics are unknown.

2.3 Vessel characteristics

The level detector should be mounted using its process connection, and in a horizontal or vertical orientation so that the liquid medium can flow freely in the gap between the forks.

A vessel (tank) or pipe can be almost any shape or type, but check that the process conditions are within the operating limits of the level detector.

Avoid installing near agitators and inlet pipes where the forks are likely to be splashed and cause a false detection of a wet condition. False detection events can be minimized by a programmable delay that allows time for the fork to dry.

Never force the level detector into a vessel (tank) or pipe space. Any contact with the opposite wall, or in-tank objects, could damage the forks and other wetted-process parts.

Extended length versions require supports at regular spaced intervals.

2.4 Application examples

Applications for the Rosemount 2140 version of the level detector include overflow prevention (Figure 2-1), high and low level alarms, pump protection, and separation processes (Figure 2-2).

The Rosemount 2140:SIS version is certified to IEC 61508 for safety-critical applications. Applications also include overflow prevention, high and low level alarms, and pump protection.

Figure 2-1: Overflow Prevention

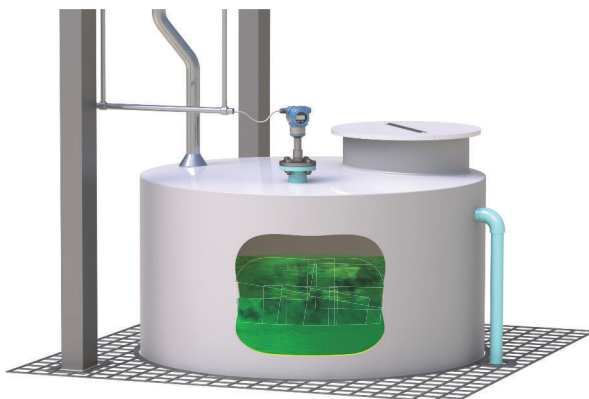
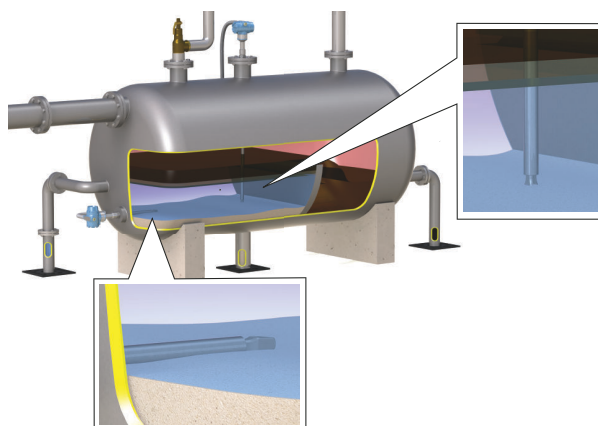

Figure 2-2: High and Low level Alarms and Pump Control



2.5 Components of the level detector

Figure 2-3 shows the components of a Rosemount 2140.

Figure 2-3: Rosemount 2140 Features

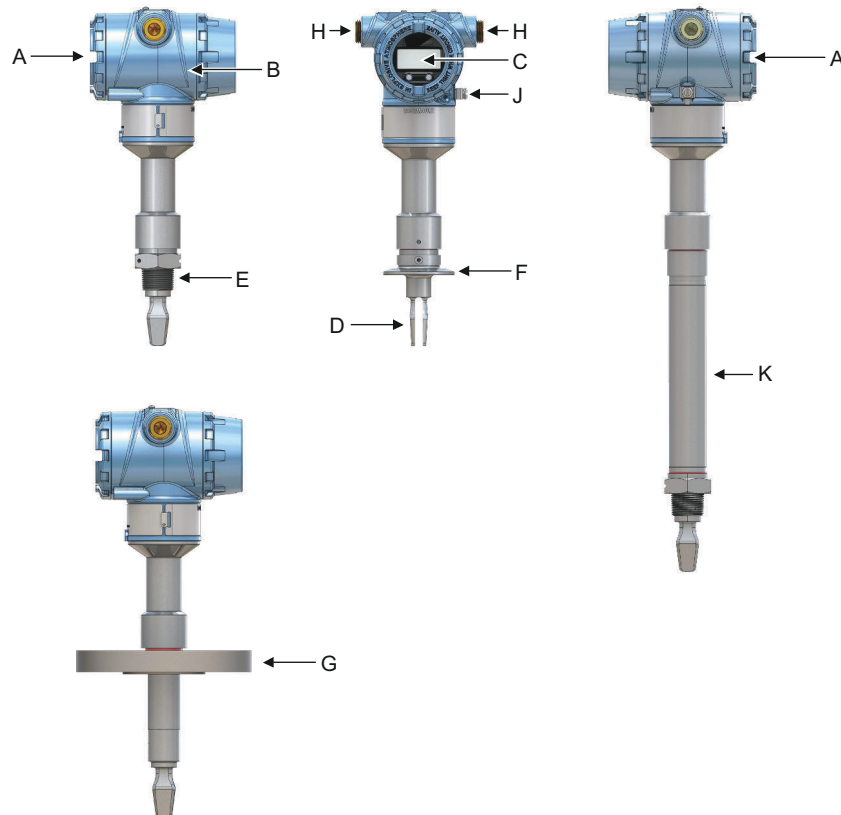

- A. Terminal compartment
- B. Electronics housing
- C. LOI display (optional)
- D. 'Fast drip' forks
- E. Threaded process connection (BSPT (R) or BSPP (G))
- F. Tri Clamp process connection
- G. Flanged process connection
- H. Two cable/conduit entries ($\frac{1}{2}$ -14 ANPT or M20 x 1.5)
- I. External ground screw
- J. Thermal tube (on high temperature version only)

2.5.1 Short fork technology

Using short-fork technology, the device can be used in almost all liquid applications. Extensive research has maximized the operational effectiveness of the fork design, making it suitable for most liquid mediums including coating liquids, aerated liquids, and slurries.

2.5.2 Fork design

The “fast drip” design allows the liquid to be quickly drawn away from the fork tip, making the Rosemount 2140 quicker and more responsive in high density or viscous liquid applications.

Figure 2-4: “Fast drip” forks



3 Mechanical installation

3.1 Safety messages

Instructions and procedures in this section may require special precautions to ensure the safety of the personnel performing the operations. Information that potentially raises safety issues is indicated by a warning symbol () . Refer to the following safety messages before performing an operation preceded by this symbol.

WARNING

Failure to follow safe installation and servicing guidelines could result in death or serious injury.

Ensure the level detector is installed by qualified personnel and in accordance with applicable code of practice.

Use the level detector only as specified in this manual. Failure to do so may impair the protection provided by the level detector.

The weight of a level detector with a heavy flange and extended fork length may exceed 37 lb. (18 kg). A risk assessment is required before carrying, lifting, and installing the level detector.

For installations in hazardous locations, the level detector must be installed according to the Rosemount 2140 and 2140:SIS Level Detectors [Product Certifications](#) document.

Repair, e.g. substitution of components, etc. may jeopardize safety and is under no circumstances allowed.

WARNING

Explosions could result in death or serious injury.

Verify that the operating atmosphere of the level detector is consistent with the appropriate hazardous locations certifications.

Before connecting a handheld communicator in an explosive atmosphere, ensure that the instruments in the loop are installed in accordance with intrinsically safe or non-incendive field wiring practices.

In explosion-proof/flameproof and non-incendive installations, do not remove the housing covers when power is applied to the level detector.

Both housing covers must be fully engaged to meet flameproof/explosion-proof requirements.

⚠ WARNING

Electrical shock could cause death or serious injury.

Avoid contact with the leads and terminals. High voltage that may be present on leads can cause electrical shock.

Ensure the power to the level detector is off, and the lines to any other external power source are disconnected or not powered while wiring the level detector.

Ensure the wiring is suitable for the electrical current and the insulation is suitable for the voltage, temperature, and environment.

⚠ WARNING

Process leaks could result in death or serious injury.

Ensure the level detector is handled carefully. If the process seal is damaged, gas might escape from the vessel (tank) or pipe.

⚠ WARNING

Physical access

Unauthorized personnel may potentially cause significant damage to and/or misconfiguration of end users' equipment. This could be intentional or unintentional and needs to be protected against.

Physical security is an important part of any security program and fundamental to protecting your system. Restrict physical access by unauthorized personnel to protect end users' assets. This is true for all systems used within the facility.

⚠ CAUTION

Hot surfaces

The flange and process seal may be hot at high process temperatures. Allow to cool before servicing.



3.2 Installation considerations

Before installing the level detector, review the safety, environmental, application, and pre-installation sections.

3.2.1 Environmental considerations

The Rosemount 2140 is weatherproof and protected against the ingress of dust, but must be protected from flooding. Avoid installing the level detector near heat sources.

Figure 3-1: Environmental Considerations

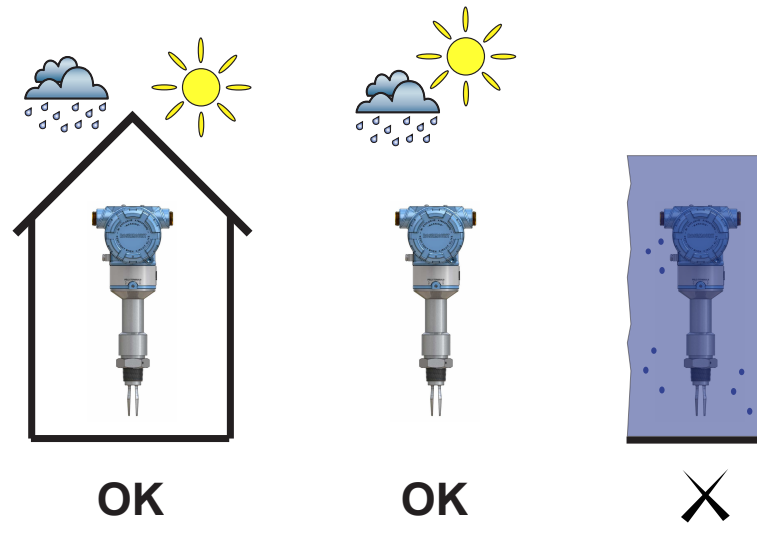

3.2.2 Application considerations

The level detectors can be mounted in an open or closed tank, or a pipe. There is a wide range of threaded, flanged, and hygienic process connection options.

For most liquids, including coating, aerated liquids and slurries, the function is virtually unaffected by flow, turbulence, bubbles, foam, vibration, solid particles, build-up, or properties of the liquid medium.

Avoid process medium build-up on the forks

Avoid situations where a drying and coating process medium may create an excessive build-up or implement preventative maintenance programs to ensure the build-up is not enough to impair performance (see [Figure 3-2](#)).

Always ensure:

- There is sufficient distance between build-up on the tank wall and the fork.
- There is no risk of 'bridging' the level switch forks.

Examples of products that can create 'bridging' of forks and impair performance are dense paper slurries and bitumen.

Figure 3-2: Avoid Product Build-up

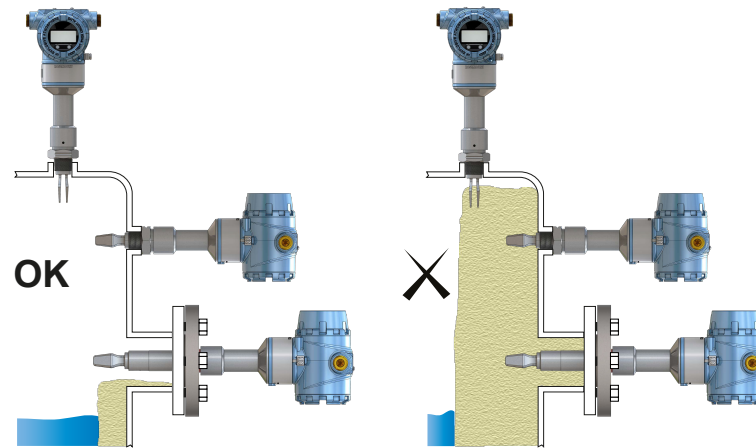

Operating temperature and pressure ranges

Ensure the process is operating within the instrument operating temperature and pressure ranges.

Liquid density requirements

Minimum liquid density is 0.4 SG (400 kg/m³).

Liquid viscosity range

Up to 10000 cP (centiPoise) when operating in the Normal mode.

Up to 1000 cP (centiPoise) when operating in Enhanced mode.

Foams

In almost all cases, the Rosemount 2140 is insensitive to foams (i.e. does not see the foam).

However in rare occasions, some very dense foams may be seen as liquid; known examples of this are found in ice-cream and orange juice manufacturing.

Switching point

The switching point varies with different liquid densities. The switching point (SP) and hysteresis (HY) for water are shown in [Figure 3-3](#).

Figure 3-3: Switching Point in Inches (Millimeters)

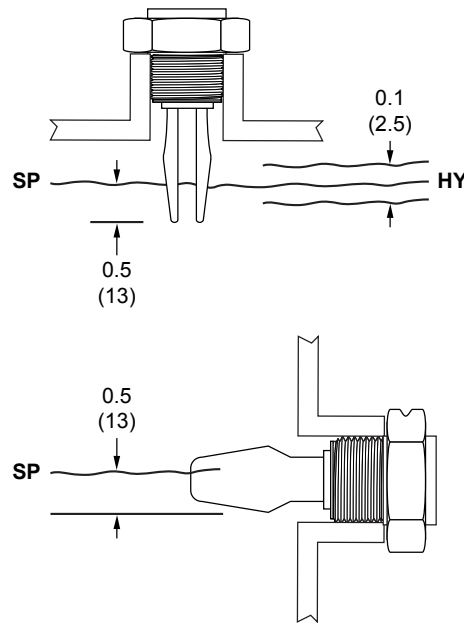

Note

When mounted vertically, a low density medium has a switching point closer to the process connection. A high density medium has a switching point closer to fork tip.

3.2.3 Pre-installation considerations

Measurement accuracy is dependent upon the proper installation of the device. Keep in mind the need for easy access, personnel safety, practical field calibration, and a suitable environment for the device.

Device identification

To identify a version of the level detector, see the label on the housing.

How to handle a level detector

Handle the level detector with great care.

The weight of the level detector with a heavy flange and extended fork length may exceed 37 lb. (18 kg). A risk assessment is required to be done before carrying, lifting, and installing the level detector.

Use both hands to carry the extended length and high temperature versions, and do not hold a level detector by the forks (see [Figure 3-4](#)).

Figure 3-4: Handling

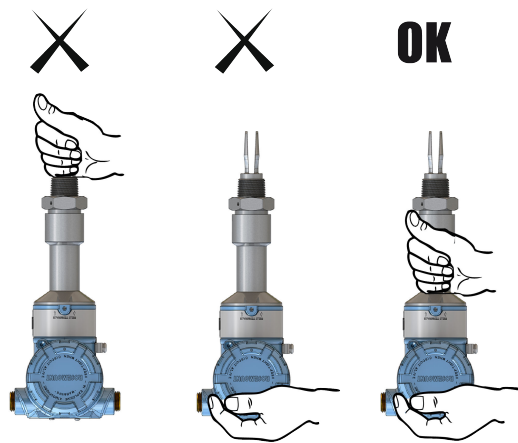

Make no alterations to the level detector

Never make any alterations to the mechanical or electrical features of the level detector (see [Figure 3-5](#)).

Figure 3-5: Make No Alterations

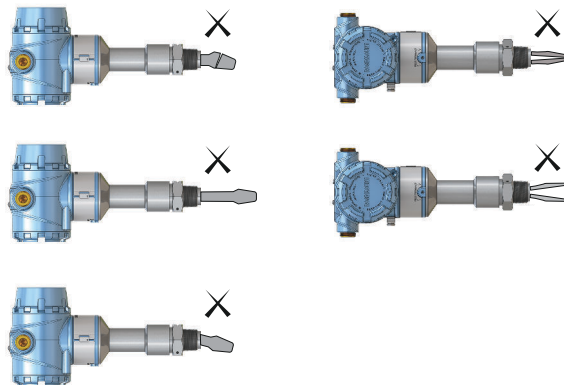

Allow adequate space outside tank or pipe

Mount a level detector so that it is removable and allow both covers to be removed. Ensure there is also enough room for fitting cable glands and cables.

Clearances:

- A clearance of 0.75 in. (19 mm) is required for the standard covers to be removed.
- If an LCD display is installed, provide 3 in. (76.2 mm) of clearance for the extended cover to be removed.

Note

The electronics housing can be rotated for optimal viewing position of an LCD display (if fitted) and to assist with the cabling.

Covers installation

Ensure a proper seal by installing the electronics housing covers so that metal contacts metal. Always use Emerson's O-rings.

Mounting orientation

Mount the Rosemount 2140 at any angle that allows the level of the process medium to rise, fall, or flow through the fork gap.

Related information

[Correct fork alignment](#)

Pipe installation requirements

- The inside pipe diameter (D) must be 1.4 in. (35 mm) or larger.
- Ensure the fork tines intrude at least 0.9 in. (22 mm) into the pipe.
- Keep at least 0.3 in. (7 mm) of clearance between the fork tines and the pipe wall.

Figure 3-6: Pipe Installation

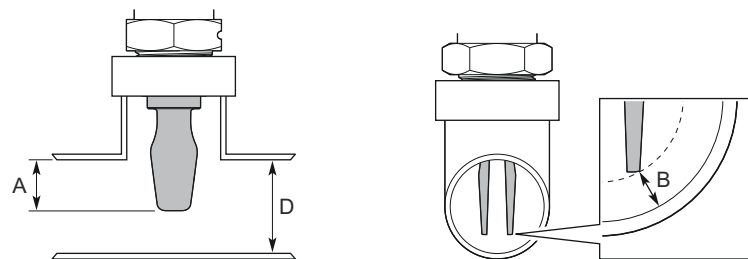

A. Minimum intrusion 0.9 in. (22 mm)

B. Minimum clearance 0.3 in. (7 mm)

Other recommendations

- Avoid:
 - Installing near to liquid entering the tank at the filling-point.
 - Heavy splashing on the forks.Increasing the sensor output delay reduces accidental detection caused by splashing.
- Always ensure:
 - The overall system is tested during commissioning.
 - The installation does not create tank crevices around the forks where a liquid medium may collect. This event can happen with high-viscosity and high-density liquids.
 - The forks do not come into contact with the vessel (tank) or pipe wall, internal fittings, or any other obstructions.
- Extra consideration is needed if the plant vibration is close to the 1400 Hz operating frequency of the fork.

Required supports for extended fork

Supporting the extended fork avoids long fork length vibration.

Figure 3-7: Vertical Installation

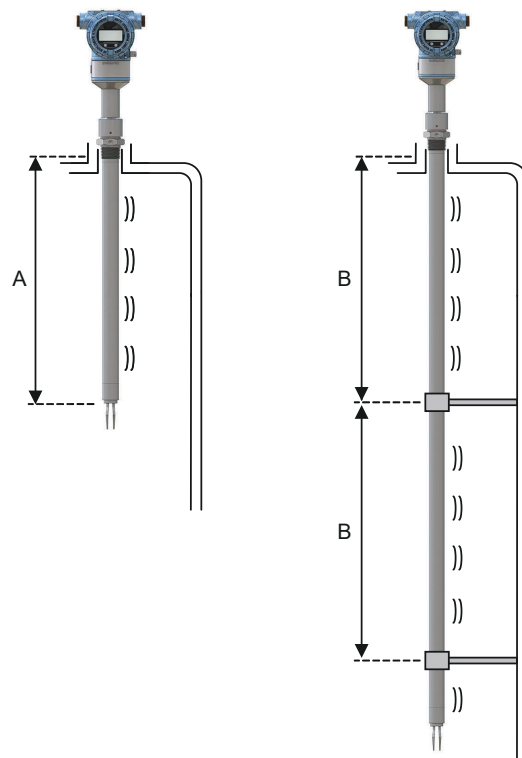

- A. Maximum 3.28 ft. (1.0 m)
- B. 3.28 ft. (1.0 m)

Figure 3-8: Horizontal Installation

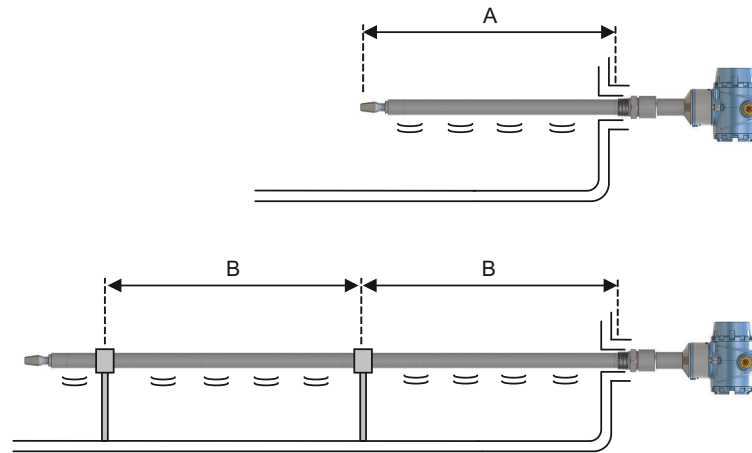

A. Maximum 3.28 ft. (1.0 m)

B. 3.28 ft. (1.0 m)

3.3 Installation procedures

3.3.1 Process connection seals

Figure 3-9: Process Connection Seals

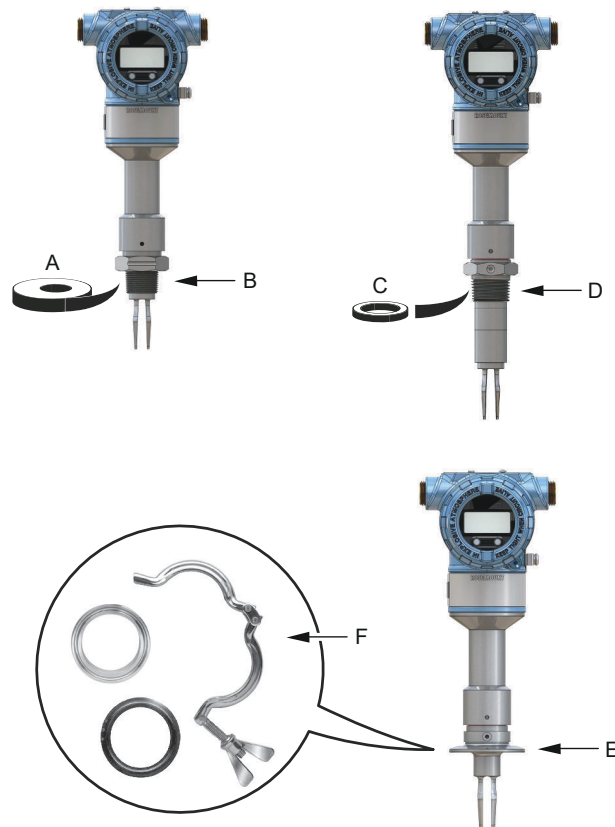

- A. PTFE tape
- B. NPT or BSPT (R) thread
- C. Gasket
- D. BSPP (G) thread
- E. Tri Clamp
- F. The Tri Clamp seal is supplied in an accessory kit

3.3.2 Correct fork alignment

Fork alignment in a vessel (tank) installation

The fork is correctly aligned by positioning the groove or notch as indicated (Figure 3-10).

Figure 3-10: Correct Fork Alignment for Vessel (Tank) Installation

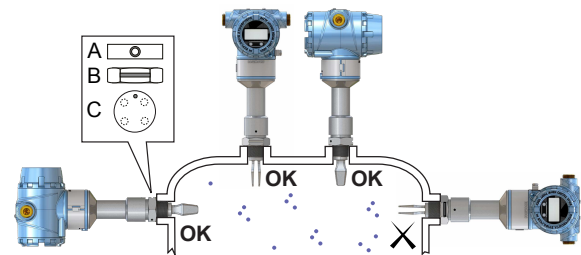

- A. Tri Clamp process connections have a circular notch
- B. Threaded process connections have a groove
- C. Flanged process connections have a circular notch

Fork alignment in a pipe installation

The fork is correctly aligned by positioning the groove or notch as indicated (Figure 3-11).

Figure 3-11: Correct Fork Alignment for Pipe Installation

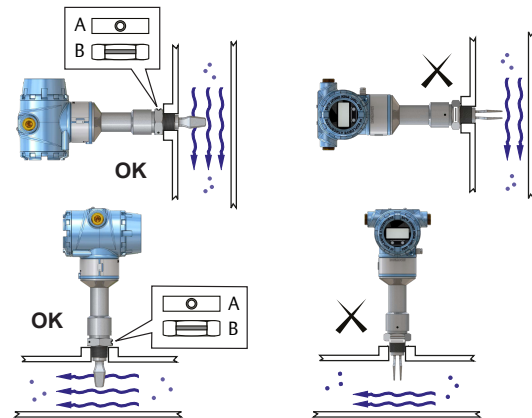

- A. Tri Clamp process connections have a circular notch
- B. Threaded process connections have a groove

3.3.3 Mounting the threaded version

Threaded vessel (tank) or pipework connection

Procedure

1. Seal and protect the threads. Use anti-seize paste or PTFE tape according to site procedures.

A gasket may be used as a sealant for BSPP (G) threaded connections.

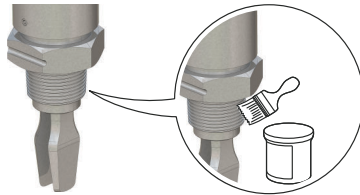

2. Screw the level detector into the process connection.

Note

Tighten using the hexagon nut only.

Figure 3-12: Vertical Installation

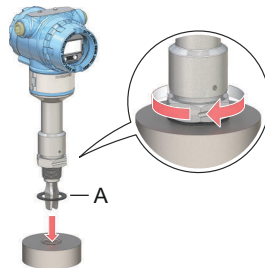

A. Gasket for BSPP (G) threaded connection

Figure 3-13: Horizontal Installation

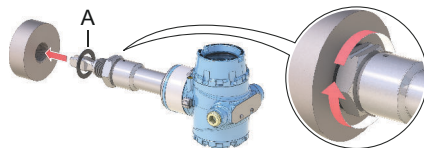

A. Gasket for BSPP (G) threaded connection

Threaded flange connection

Procedure

1. Place the customer-supplied flange and gasket on the vessel (tank) nozzle.

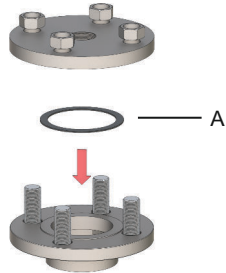

A. Gasket (customer supplied)

2. Tighten the bolts and nuts with sufficient torque for the flange and gasket.

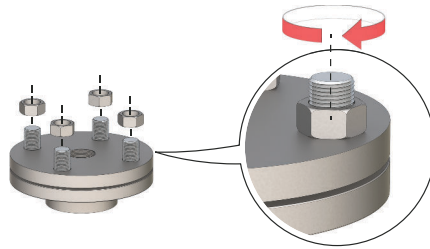

3. Seal and protect the threads. Use anti-seize paste or PTFE tape according to site procedures.

A gasket may be used as a sealant for BSPP (G) threaded connections.

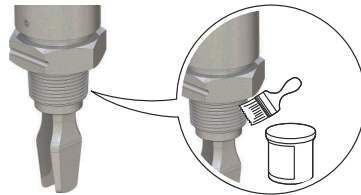

4. Screw the level detector into the flange thread.

Note

Tighten using the hexagon nut only.

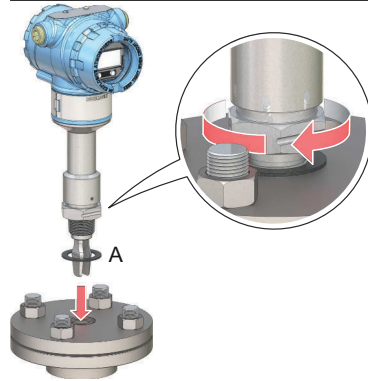

A. Gasket for BSPP (G) threaded connection

3.3.4 Mounting the flanged version

Procedure

1. Lower the level detector into the nozzle.

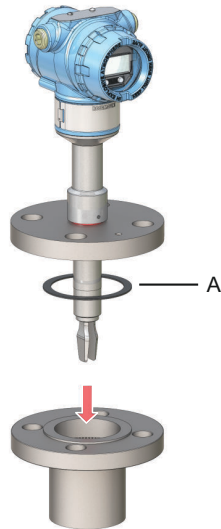

A. Gasket (customer supplied)

2. Tighten the bolts and nuts with sufficient torque for the flange and gasket.

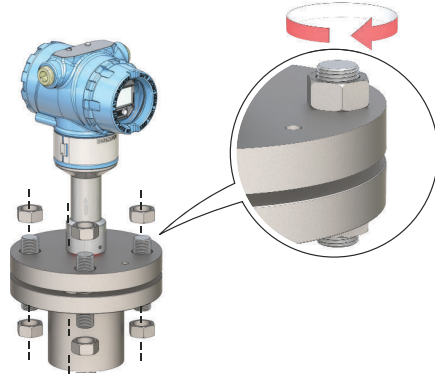

3.3.5 Mounting the Tri Clamp version

Procedure

1. Lower the level detector into the flange face.

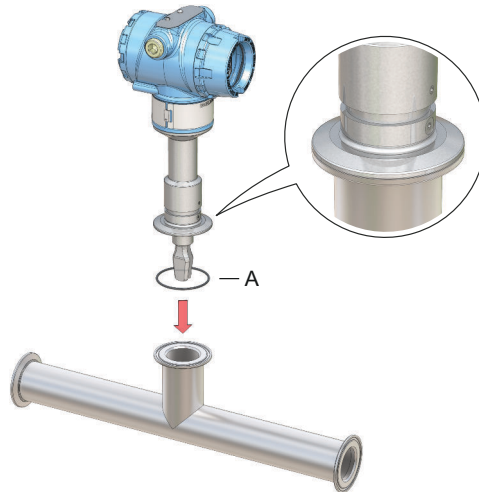

A. Seal (supplied with Tri Clamp)

2. Fit the Tri Clamp.

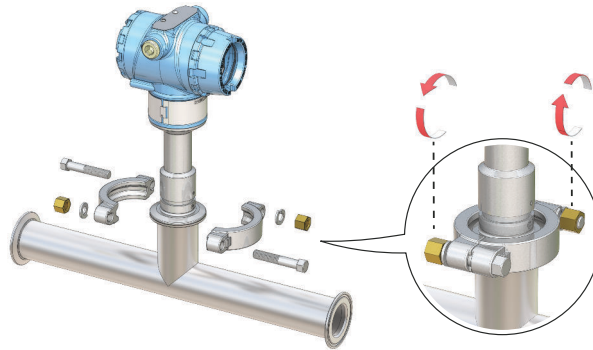

3.4 Adjust display orientation (optional)

To improve field access to wiring or to better view the optional LCD display:

Procedure

1. Loosen the set screw until the level detector housing can rotate smoothly.
Do not unscrew all the way. Rotating the housing, without this screw in place, can damage the internal wiring.
2. First, rotate the housing clockwise to the desired location.
If the desired location cannot be achieved due to thread limit, rotate the housing counterclockwise.
3. Re-tighten the set screw.

Note

Do not attempt to rotate the display beyond the thread limits.

Figure 3-14: Housing Rotation

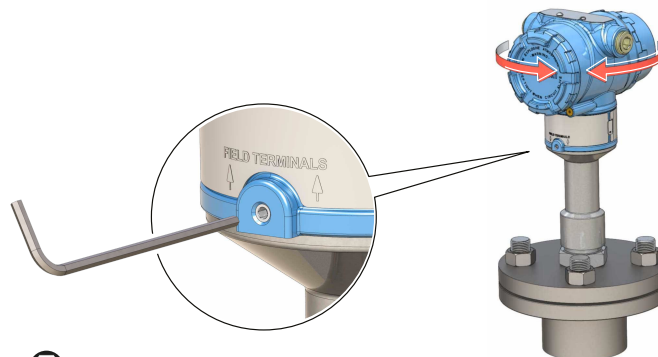

 Torque 30 in-lb (3 Nm)
H3/32 in.

4 Electrical installation

4.1 Prepare the electrical connections

4.1.1 Cable selection

Use 24–14 AWG wiring. Twisted-pairs and shielded wiring is recommended for environments with high EMI (electromagnetic interference). Two wires can be safely connected to each terminal screw.

4.1.2 Cable glands/conduits

For intrinsically safe, explosion-proof/flameproof, and dust-proof installations, only use certified cable glands or conduit entry devices. Ordinary location installations can use suitably rated cable glands or conduit entry devices to maintain the Ingress Protection (IP) rating.

Unused conduit entries must always be sealed with a suitably rated blanking/stopping plug.

Note

Do not run signal wiring in conduit or open trays with power wiring or near heavy electrical equipment.

4.1.3 Power supply

Each level detector operates on 10.5 – 42.4 Vdc (10.5 – 30 Vdc in Intrinsically Safe installations) at the level detector terminals.

4.1.4 Power consumption

Maximum of 1 W, and current maximum is 23 mA.

4.1.5 Hazardous areas

When the device is installed in hazardous areas (classified locations), local regulations and the conditions-of-use specified in applicable certificates must be observed. Review the Rosemount 2140 [Product Certifications](#) document for information.

4.1.6 Load limitations

For HART® communications, a minimum load resistance of 250 Ω is required.

The maximum loop resistance is determined by the voltage level of the external power supply (see [Figure 4-1](#)).

Figure 4-1: Load Limitations

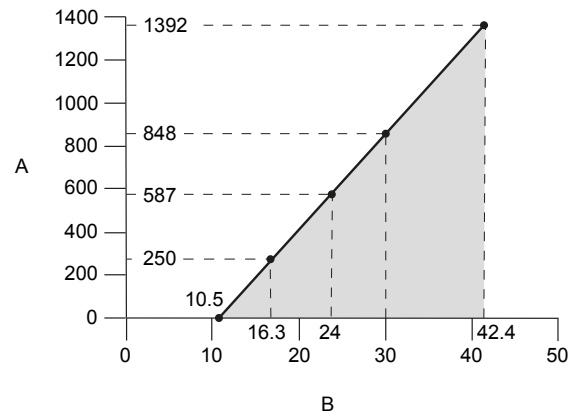

Maximum loop resistance = $43.5 \times (\text{external power supply voltage} - 10.5)$

- A. Loop resistance in Ohms (Ω)
- B. External power supply voltage (Vdc)

4.1.7

Wiring diagram

Figure 4-2: 4-20 mA/HART® Communication

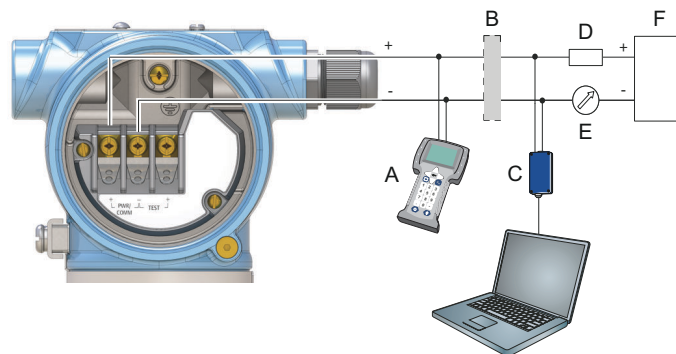

- A. Handheld communicator
- B. Approved IS barrier (for Intrinsically Safe installations only)
- C. HART modem
- D. Load resistance ($\geq 250 \Omega$)
- E. Current meter
- F. Power supply

4.1.8 Grounding

Make sure grounding is done according to national and local electrical codes. Failure to do so may impair the protection provided by the equipment.

Grounding the housing

The most effective grounding method is direct connection to earth ground with minimal impedance. There are two grounding screw connections provided (see [Figure 4-3](#)).

Figure 4-3: Ground Screws

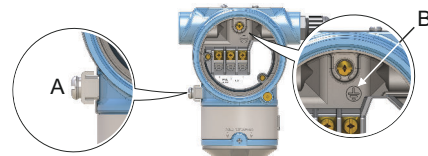

- A. External ground screw
- B. Internal ground screw

Signal cable shield grounding

Make sure the instrument cable shield is:

- Trimmed close and insulated from touching the housing.
- Continuously connected throughout the segment.
- Connected to a good earth ground at the power supply end.

Figure 4-4: Signal Cable Shield Grounding at Power Supply End

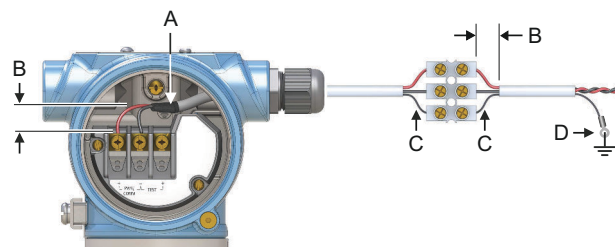

- A. Trim shield and insulate
- B. Minimize distance
- C. Trim shield
- D. Connect shield back to the power supply ground

Transient protection terminal block grounding

The level detector can withstand electrical transients of the energy level usually encountered in static discharges or induced switching transients. However, high-energy transients, such as those induced in wiring from nearby lightning strikes, can damage the level detector.

A transient protection terminal block can be ordered as an installed option (code T1). The lightning bolt symbol in identifies the transient protection terminal block.

Note

The transient protection terminal block does not provide transient protection unless the housing is properly grounded.

4.2 Connect wiring and power up

Procedure

1. ⚠ Verify the power supply is disconnected.
2. Remove the field terminals cover.

In an explosion-proof/flameproof installation, do not remove the level detector covers when power is applied to the unit. Covers are also not to be removed in extreme environmental conditions.

- a) Turn the jam screw clockwise until it is completely threaded into the housing.

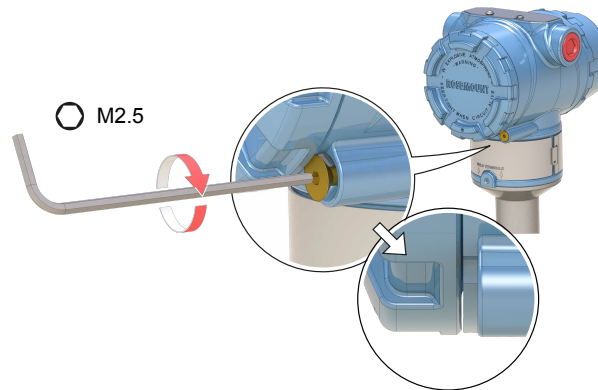

- b) Turn the cover counter-clockwise until it is removed from the housing. Keep the cover O-ring safe. Replace the O-ring if it is worn or damaged.

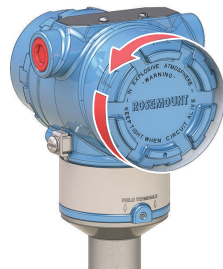

3. Remove the plastic plugs.



4. Pull the cable through the cable gland/conduit.
Identification of thread size and type:

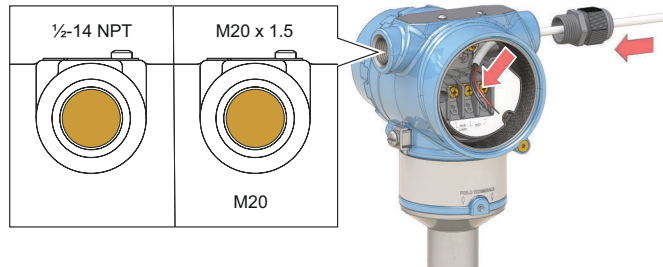

5. Connect the cable wires.

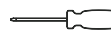
 Torque 7 in-lb (0.8 Nm)

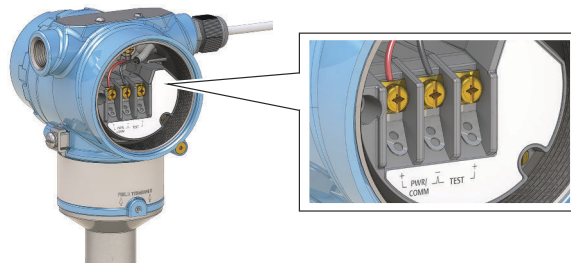

6. Ensure proper grounding.

7. Tighten the cable gland.
Apply PTFE tape or other sealant to the threads.

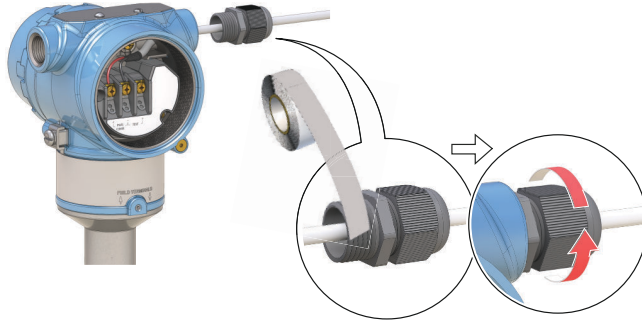

Note

Make sure to arrange the wiring with a drip loop.



8. Plug and seal the unused conduit connection to avoid moisture and dust accumulation inside the housing.
Apply PTFE tape or other sealant to the threads.

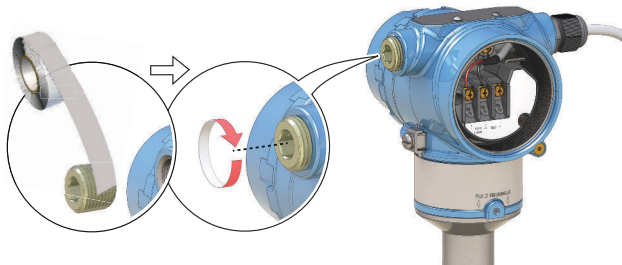

9. Attach and tighten the cover.

- a) Verify the cover jam screw is completely threaded into the housing.

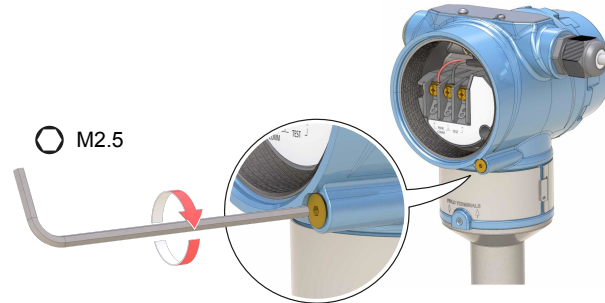

- b) Attach and tighten the cover.

⚠ Make sure the cover is fully engaged. There should be no gap between the cover and the housing.

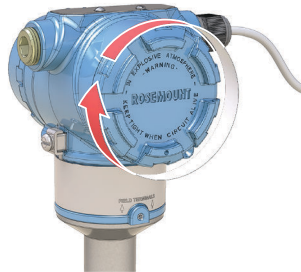

10. ⚠ Required for explosion-proof/flameproof installations only:

- a) Turn the cover jam screw counterclockwise until it contacts the cover.

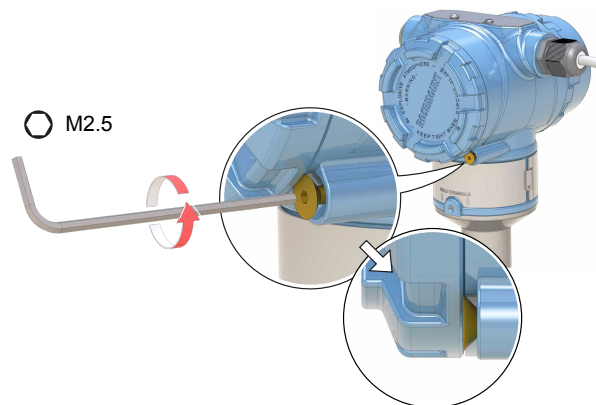

- b) Turn the jam screw an extra ½ turn counterclockwise to secure the cover.

- c) Verify that the cover cannot be removed.

11. Connect the power supply.

5 Configuration

5.1 Safety messages

Instructions and procedures in this section may require special precautions to ensure the safety of the personnel performing the operations. Information that potentially raises safety issues is indicated by a warning symbol () . Refer to the following safety messages before performing an operation preceded by this symbol.

WARNING

Failure to follow safe installation and servicing guidelines could result in death or serious injury.

Ensure the level detector is installed by qualified personnel and in accordance with applicable code of practice.

Use the level detector only as specified in this manual. Failure to do so may impair the protection provided by the level detector.

The weight of a level detector with a heavy flange and extended fork length may exceed 37 lb. (18 kg). A risk assessment is required before carrying, lifting, and installing the level detector.

For installations in hazardous locations, the level detector must be installed according to the Rosemount 2140 and 2140:SIS Level Detectors [Product Certifications](#) document.

Repair, e.g. substitution of components, etc. may jeopardize safety and is under no circumstances allowed.

WARNING

Explosions could result in death or serious injury.

Verify that the operating atmosphere of the level detector is consistent with the appropriate hazardous locations certifications.

Before connecting a handheld communicator in an explosive atmosphere, ensure that the instruments in the loop are installed in accordance with intrinsically safe or non-incendive field wiring practices.

In explosion-proof/flameproof and non-incendive installations, do not remove the housing covers when power is applied to the level detector.

Both housing covers must be fully engaged to meet flameproof/explosion-proof requirements.

⚠ WARNING

Electrical shock could cause death or serious injury.

Avoid contact with the leads and terminals. High voltage that may be present on leads can cause electrical shock.

Ensure the power to the level detector is off, and the lines to any other external power source are disconnected or not powered while wiring the level detector.

Ensure the wiring is suitable for the electrical current and the insulation is suitable for the voltage, temperature, and environment.

⚠ WARNING

Process leaks could result in death or serious injury.

Ensure the level detector is handled carefully. If the process seal is damaged, gas might escape from the vessel (tank) or pipe.

⚠ WARNING

Physical access

Unauthorized personnel may potentially cause significant damage to and/or misconfiguration of end users' equipment. This could be intentional or unintentional and needs to be protected against.

Physical security is an important part of any security program and fundamental to protecting your system. Restrict physical access by unauthorized personnel to protect end users' assets. This is true for all systems used within the facility.

⚠ CAUTION

Hot surfaces

The flange and process seal may be hot at high process temperatures. Allow to cool before servicing.



5.2 Configuration tools

- Field Device Integration (FDI) based systems
- Device Descriptor (DD) based systems
- Device Type Manager (DTM™) based systems
- Local Operator Interface (LOI)

5.3 Local Operator Interface (LOI)

The LOI requires option code M4 to be selected when ordering a level detector.

It uses a character display (Figure 5-1) to indicate the live output state, diagnostic messages, and menus. There are two rows of characters, with 8 on the upper row and 6 on the lower row.

Figure 5-1: Local Operator Interface (LOI) Display

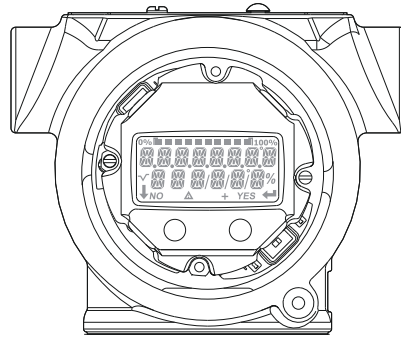

Related information

[Local Operator Interface \(LOI\) menu trees](#)

5.3.1 LOI configuration buttons

To activate the LOI, push any of the configuration buttons. Left and right configuration buttons are located on the LCD display (accessible after removing a housing cover) and duplicated underneath the moveable top-tag.

Figure 5-2: LOI Configuration Buttons

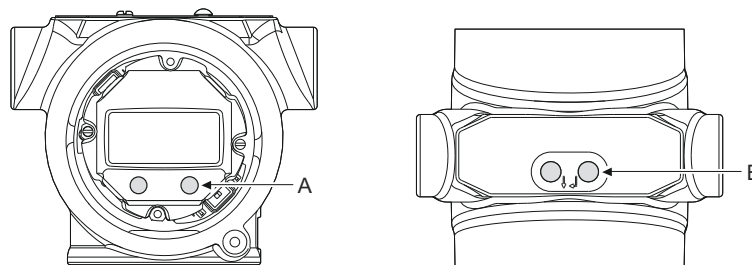



- A. Internal configuration buttons, left and right
- B. External configuration buttons, left and right

5.3.2 LOI button operation

Table 5-1 shows examples of the basic configuration button functionality. Some features in the LOI menu use multiple screens to complete their configuration. Any data entered is saved on a screen-by-screen basis, and the LOI indicates this by flashing “SAVED” on the LCD display each time.

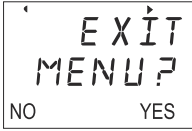
Table 5-1: LOI Button Operation

LOI screen	Button	Function
	Left	NO
	Right	YES
	Left	SCROLL DOWN
	Right	ENTER

5.4 Confirm correct device driver

Procedure

1. Verify that the correct FDI/DD/DTM Package is loaded on your systems to ensure proper communication.
2. Download the latest FDI/DD/DTM Package at Emerson.com/DeviceInstallKits or FieldCommGroup.org.

Related information

[NAMUR NE 53 revision](#)

5.5 Confirm HART[®] revision capability

If using HART-based control or asset management systems, confirm the HART capability of those systems prior to installation of the device. Not all systems are capable of communicating with HART Revision 7 protocol. This device can be configured for either HART Revision 5 or 7.

5.5.1 Switch HART revision

Procedure

1. Select **Configure** → **Manual Setup** → **HART**.
2. Under **Communication Settings**, select **Change HART Revision** and follow the on-screen instructions.

5.5.2 Switch HART revision with a generic menu

If the HART configuration tool is not capable of communicating with a HART Revision 7 device, it will load a generic menu with limited capability.

Procedure

Locate the “Message” field.

- To switch to HART Revision 5, enter **HART5** and 27 spaces in the message field.

- To switch to HART Revision 7, enter **HART7** and 27 spaces in the message field.

5.5.3 Switch HART revision using the LOI

To switch the HART revision mode using the LOI (Local Operator Interface):

Procedure

1. Press any LOI configuration button to activate the menu.
2. Scroll down (↓) and then select **EXTENDED MENU** (↵) .
3. Scroll down (↓) and then select **HART REV** (↵) .
4. To change HART revision, select **HART REV 5** (↵), or scroll down (↓) and then select **HART REV 7** (↵).
5. Exit the menu system by either waiting one minute for the **EXIT MENU?** prompt, or scrolling down menus to find and select **BACK TO MENU** and **EXIT MENU**.

5.6 Configure device using guided setup

The options available in the Guided Setup wizard include all items required for basic operation.

Procedure

1. Select **Configure** → **Guided Setup**.
2. Select **Basic Setup** and follow the on-screen instructions.

5.6.1 Configure using the LOI

The Guided Setup wizard is not available on the LOI (Local Operator Interface). See the appendix [Configuration parameters](#) for the LOI instructions to configure basic parameters, and then return here to verify configuration.

5.7 Verify the configuration

It is recommended that configuration parameters are verified prior to using the level detector live in a process.

5.7.1 Verify configuration using a handheld communicator

[Table 5-2](#) lists the configuration parameters to be reviewed before using the level detector live in a process. From the HOME screen of the handheld communicator, enter the fast key sequences as listed.

Table 5-2: Verifying Configuration (Fast Key Sequences)

Parameter	Fast key sequence	
	HART 7	HART 5
Tag	1, 8, 1, 2	1, 8, 1, 1
Model	1, 8, 1, 3	1, 8, 1, 3
Primary Variable	3, 2, 1, 1	3, 2, 1, 1
Sensor Operating Mode	2, 2, 1, 1, 1	2, 2, 1, 1, 1
Sensor Output Delay	2, 2, 1, 1, 2	2, 2, 1, 1, 2
Media Density	2, 2, 1, 1, 3	2, 2, 1, 1, 3
Sensor Fault Delay	2, 2, 1, 3, 2	2, 2, 1, 3, 2
Current Output Type ⁽¹⁾	2, 2, 2, 1, 1	2, 2, 2, 1, 1
Custom Off Current ⁽²⁾	2, 2, 2, 1, 3	2, 2, 2, 1, 3
Custom On Current ⁽²⁾	2, 2, 2, 1, 4	2, 2, 2, 1, 4
PV URV (Upper Range Value) ⁽³⁾	2, 2, 2, 2, 2	2, 2, 2, 2, 2
PV LRV (Lower Range Value) ⁽³⁾	2, 2, 2, 2, 3	2, 2, 2, 2, 3
High Alarm Level ⁽⁴⁾	2, 2, 2, 5, 3	2, 2, 2, 5, 3
Low Alarm Level ⁽⁴⁾	2, 2, 2, 5, 6	2, 2, 2, 5, 6
High Saturation Level ⁽³⁾⁽⁴⁾	2, 2, 2, 5, 4	2, 2, 2, 5, 4
Low Saturation Level ⁽³⁾⁽⁴⁾	2, 2, 2, 5, 5	2, 2, 2, 5, 5
Alarm Switch Position/Direction	2, 2, 2, 5, 2	2, 2, 2, 5, 2

(1) Only applicable when the Primary Variable is mapped to the Output State variable.

(2) Only applicable when Current Output Type is set to "Custom".

(3) Only applicable when the Primary Variable is mapped to the Sensor Frequency or Scaled Variable variables.

(4) Alarm level and saturation level depend on the Alarm Level switch setting and the ordered Alarm Level option code.

5.7.2 Verify configuration using the LOI

Table 5-3 lists the configuration parameters to be reviewed on the LOI (Local Operator Interface) before using the level detector live in a process.

Procedure

1. Press any LOI configuration button to activate the menu.
2. Select **VIEW CONFIG** (←↓).
3. Scroll down (↓) to review the parameters.
4. Exit the menu system by either waiting one minute for the **EXIT MENU?** prompt, or scrolling down menus to find and select **BACK TO MENU** and **EXIT MENU**.

Table 5-3: Verifying Configuration (LOI)

Parameter	Information
TAG	Free-form text for giving the device an identity
MODEL	e.g. "2140"
T Range	Operating temperature range
IS PV	Primary Variable mapping
S UNIT	Secondary Variable units
T UNIT	Electronics temperature units
OP MODE	Operating mode
DENSITY	Media density
O DLY	Sensor output delay
F DLY	Fault output delay
AOMODE ⁽¹⁾	Analog Output operating mode
OFF MA ⁽¹⁾	Custom mA output for 'off' output state
ON MA ⁽¹⁾	Custom mA output for 'on' output state
S-START	Device test/proof test at start
URV ⁽²⁾	Upper range value for analog output
LRV ⁽²⁾	Lower range value for analog output
DAMPING	Scaled Variable damping
HIALRM ⁽³⁾	High alarm level
LOALRM ⁽³⁾	Low alarm level
HI SAT ⁽²⁾⁽³⁾	High saturation level
LO SAT ⁽²⁾⁽³⁾	Low saturation level
ALARM	Alarm switch position/direction
SECURE	Security switch position

(1) Only visible when the Primary Variable ("PV") is mapped to the Output State variable.

(2) Only visible when the Primary Variable ("PV") is mapped to the Sensor Frequency or Scaled Variable variables.

(3) Alarm level and saturation level depend on the Alarm Level switch setting and the ordered Alarm Level option code.

5.8 Multidrop communication

Multidropping refers to the connection of several devices to a single communications transmission line. Communication between the host device and another device takes place digitally with the analog output of the level detector deactivated. [Figure 5-3](#) shows a typical multidrop network.

Figure 5-3: Typical Multidrop Network

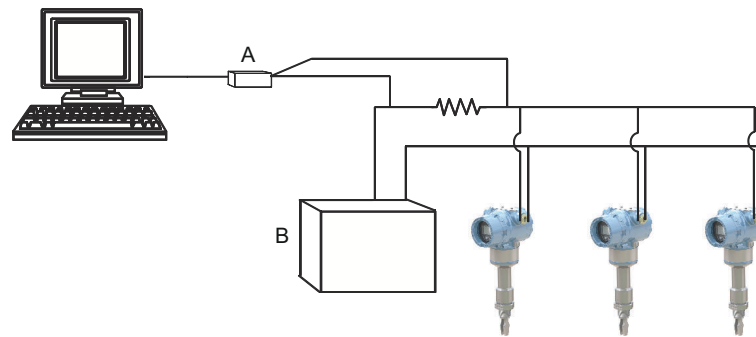

- A. HART modem
- B. Power supply

Multidrop installation requires consideration of the update rate necessary from each device, the combination of different device types, and the length of the transmission line. Communication with devices can be accomplished with HART modems and a host implementing the HART protocol. Each device is identified by a unique address and responds to the commands defined in the HART protocol.

Note

A multidrop device in HART Revision 7 mode has a fixed analog output of 4 mA for all but one device. Only one device is allowed to have an active analog signal.

The level detector is set to address zero (0) at the factory, which allows operation in the standard point-to-point manner with a 4–20 mA output signal.

5.8.1 Establish multidrop communication

To activate multidrop communication, the address must be changed to a number from 1 to 15 for HART Revision 5, or 1 to 63 for HART Revision 7. This change deactivates the 4–20 mA analog output, sending it to 4mA.

It also disables the failure mode alarm signal, which is controlled by the upscale/downscale switch position. Failure signals in multidropped devices are communicated through HART messages.

Procedure

1. Select **Configure** → **Manual Setup** → **HART**.
2. Under **Communication Settings**, select **Change Polling Address** and follow the on-screen instructions.

5.9 HART burst mode

Burst mode is compatible with the analog output signal. Due to the way that HART protocol features simultaneous digital and analog data transmission, the analog value can drive other equipment in the loop while the control system is receiving the digital information.

Burst mode applies only to the transmission of dynamic variables (PV, SV, TV, and QV), and does not affect the way other data is accessed. However, when activated, burst mode can slow down communication of non-dynamic variable data to the host by 50%.

Access to information, other than dynamic variables, is obtained through the normal poll-and-response method of HART communication. The configuration tool or control system may request any of the information that is normally available while the device is in burst mode. Between each message sent by the device, a short pause allows a host (configuration tool or control system) to initiate a request.

5.9.1 Configure burst mode

Prerequisites

Check if the host system supports burst mode and what options are required. The burst from the level detector will be at a continuous rate of once every 0.5 seconds.

Procedure

1. Select **Configure** → **Manual Setup** → **HART**.
2. Under **Burst Mode Configuration**, in the **Burst mode** list, select **Enabled**.
3. In the **Burst command** list, select the desired burst option (e.g. **PV, SV, TV, and QV**).
4. Optional: Select **Configure Additional Messages** to configure **Burst Message 2** and **Burst Message 3**.

5.10 Security

There are four security methods:

- Security switch
- HART lock
- Configuration button lock
- Local Operator Interface (LOI) password

5.10.1 Alarm and security switches

Alarm level switch

Under alarm conditions, the output current is forced to a high or low level beyond the normal 4 mA to 20 mA operating range.

The Alarm Level hardware switch is set to a 'H' or 'L' position to determine if it is the high or low alarm current. [Figure 5-4](#) shows the Alarm Level switch inside the housing.

Security switch

The security switch is set to the Locked position to prevent configuration changes using the optional Local Operator Interface (LOI) or HART® interfaces.

[Figure 5-4](#) shows the security switch inside the housing.

Figure 5-4: Alarm Level and Security Switches

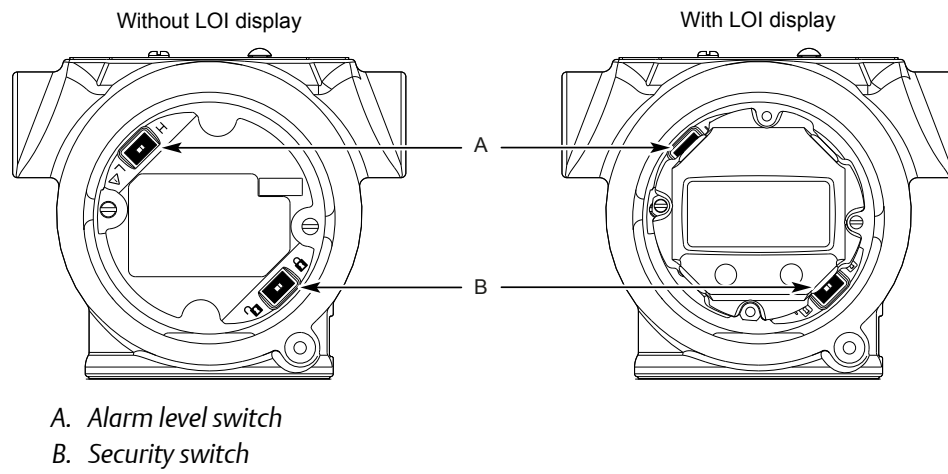

5.10.2 Set the position of the security switch

When the security switch is set to the locked position (🔒), all configuration requests made using HART, LOI, or local configuration buttons are rejected.

Procedure

1. ⚠️ Set process loop to manual and remove power.
2. Remove the housing cover.
3. Use a small screwdriver to slide the security switch to the preferred position.
4. Replace the housing cover.

Note

The cover must be fully engaged with the cover jam screw to comply with explosion-proof requirements.

View the security switch status

The position of the security switch can be checked without removing the housing cover.

Procedure

Select **Service Tools** → **Maintenance** → **Security**.

The **Write protect** box shows the status of the security switch.

View the security switch status using the LOI

The position of the security switch can be checked without removing the housing cover.

Procedure

Press any LOI configuration button to activate the menu.

The display shows **LOCK WRITE** if the security switch is enabled.

5.10.3 Set the HART lock

The HART Lock function prevents HART commands from making changes to the configuration.

Prerequisites

The device must be using HART Revision 7.

Procedure

1. Select **Configure** → **Manual Setup** → **Security**.
2. Under **HART Lock (Software)**, select **Lock/Unlock** and follow the on-screen instructions.

Related information

[Switch HART revision](#)

5.10.4 Set the configuration button lock

The configuration button lock disables all local button functionality.

Procedure

1. Select **Configure** → **Manual Setup** → **Security**.
2. In the **Configuration Buttons** list, select **Disabled** to lock the external local buttons or **Enabled** to unlock.

5.10.5 Local Operator Interface (LOI) lock

A Local Operator Interface (LOI) password can be used to prevent the review and modification of the level detector configuration using the LOI. The password is a 4-digit code that is to be set by the user.

Note

This password protection does not prevent access to the level detector configuration using HART communications.

Set the LOI password

Procedure

1. Select **Configure** → **Manual Setup** → **Security**.
2. Select **Configure Password (LOI Password Protection)** in handheld communicator) and follow the on-screen instructions.

Set the LOI password using the LOI

Procedure

1. Press any LOI configuration button to activate the menu.
2. Scroll down (↓) and then select **EXTENDED MENU** (↵)

3. Scroll down (↓) and then select **PASSWORD** (↵) .
4. Enable the LOI password protection.
5. Enter a 4-digit number as the password.
6. Exit the menu system by either waiting one minute for the **EXIT MENU?** prompt, or scrolling down menus to find and select **BACK TO MENU** and **EXIT MENU**.

6 Operation

6.1 LCD display screen messages

The optional Local Operator Interface (LOI) includes a LCD display that shows output variables and abbreviated diagnostic messages.

Figure 6-1: LOI and LCD Display (Option Code M4)

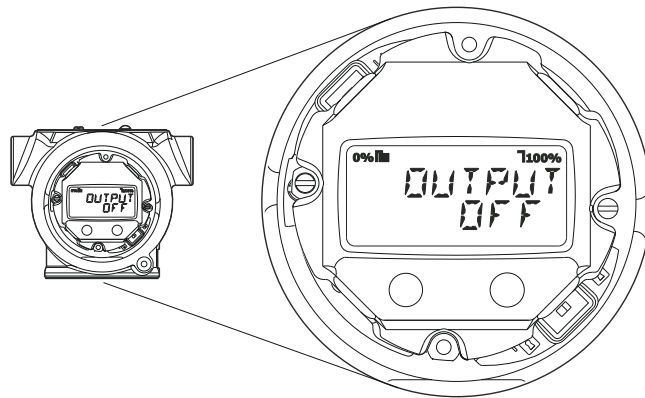

Variable screens

The level detector can display the following variables:

Table 6-1: LCD Display Variables

Parameter	Presentation on display	Description
Output State ⁽¹⁾	OUTPUT	Live output state: 'off' (0.0) or 'on' (1.0).
Sensor State	STATE	Live fork state: 'dry' (0.0) or 'wet' (1.0).
Sensor Frequency	Hz	Live vibration frequency of the fork.
Percent of Range Primary Variable	%RANGE	A live variable value expressed in percent within a range defined by a Lower Range Value (LRV) and an Upper Range Value (URV).
Scaled Variable ⁽²⁾	SCALED	A live variable calculated from a scaling table (as defined by pairs of input/scaled values).
Electronics Temperature	DEG F / DEG C	The live temperature at the electronics.
Supply Voltage	V	The live voltage at the terminals.
Analog Output	MA	The live analog output current.

(1) Default parameter displayed.

(2) Not available for Rosemount 2140: SIS.

6.2 Set up the LCD display

It is possible to specify the variables to be presented on the optional LCD display.

Procedure

1. Select **Configure** → **Manual Setup** → **Display**.
2. Select the desired variables to be displayed on the LCD display.

6.2.1 Set up the LCD display using the LOI

It is possible to specify the variables to be presented on the optional LCD display.

Procedure

1. Press any LOI configuration button to activate the menu.
2. Scroll down (↓) and then select **DISPLAY** (↔).
3. **OUTPUT** is the first variable in this menu.
 - a) Select **OUTPUT** (↔).
 - b) Select **No** or **Yes** to answer the prompt asking if it is to be displayed or not.
4. For all other variables of interest:
 - a) Scroll down (↓) and then select (↔).
 - b) Select **No** or **Yes** to answer the prompt asking if it is to be displayed or not.

The last item, **STARTUP**, enables or disables the startup screens when the level detector is started. By default, this is not enabled. Startup screens include a display test and the **VIEW CONFIG** content.
5. Exit the menu system by either waiting one minute for the **EXIT MENU?** prompt, or scrolling down menus to find and select **BACK TO MENU** and **EXIT MENU**.

6.3 View measurement data

Current measurement data of the primary variables are presented on the **Overview** screen. To view all current measurement values:

Procedure

1. Select **Service Tools** → **Variables**.
2. Select **Variable Summary**, **Mapped Variables**, or **Device Variables**.

6.3.1 Interpret measurement status

A “Good” or “Bad” status next to a value is an indication of the reliability or integrity of the data being received, not an indication of whether or not the value is within the configured upper or lower ranges. A value that triggers an alert, such as a high or low temperature indication, will change the overall status of the device, but the measurement might still be indicated as “Good” if the reliability of the data is good.

6.3.2 View measurement data using the LOI

The optional LOI and LCD is configurable to show a different variable every few seconds.

Related information

[Set up the LCD display using the LOI](#)

6.4 Check device status

The overall device status is presented under the **Overview** screen. The device reports diagnostic alerts when there is a device malfunction.

Procedure





1. Go to the **Overview** screen to view the overall device status.
2. If status is anything other than Good, select the button in the device status image to open a window with Active Alerts.
Active Alerts can also be obtained via **Service Tools** → **Alerts**.

Related information

[Diagnostic messages](#)

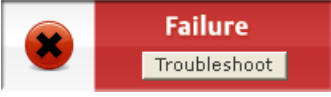
6.4.1 Device status images

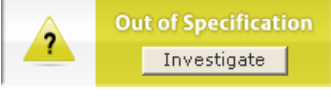
Table 6-2: Presentation of Device Status Images as per NAMUR NE 107 – AMS Device Manager

Device status image	Category	Description	Action
Device: 	Good	No active alert.	N/A
Device: 	Failure	At least one Failure alert is active.	Click the Troubleshoot button to open a window with active alerts together with recommended actions.
Device: 	Function Check	At least one Function Check alert is active (and no Failure alerts).	Click the Investigate button to open a window with active alerts together with recommended actions.
Device: 	Out of Specification	At least one Out of Specification alert is active (and no Failure or Function Check alerts).	
Device: 	Maintenance Required	At least one Maintenance Required alert is active (and no Failure, Function Check, or Out of Specification alerts).	

6.5 Partial proof testing

Partial proof testing simulates sensor changes from dry-to-wet and wet-to-dry when a level detector is already installed, but does not require the actual process to change. Comprehensive proof testing requires the forks to be immersible in a liquid and observing the output changes.

The level detector has partial proof testing support as standard, and it can be triggered locally using the Local Operator Interface (if fitted) or remotely using a HART command e.g. from a DD-based host system.

Initially, the device diagnostics are checked by the level detector before simulating sensor states. Any detected faults will end the proof test immediately, requiring further investigation.

Proof testing then exercises the analog output to produce the electrical currents representing:

- The 'off' and 'on' states (if configured for a switched output).
- Lower and upper range values (if configured for a 4–20 mA output).
- High and low alarms.

When the Primary Variable is mapped to the Scaled Variable⁽¹⁾ or Sensor Frequency device variables, the analogue output is also exercised from the low saturation level to the high saturation level.

For Safety Instrumented System (SIS) applications, the Rosemount 2140:SIS must be tested at regular intervals. This is to detect any failures not automatically detected by the device self-test at start-up and the continuous fork sensor diagnostics when operating in Enhanced mode.

Related information

[Rosemount 2140:SIS Safety Manual](#)

6.5.1 Start the remote partial proof test

Procedure

1. Select **Service Tools** → **Maintenance** → **Test**.
2. Select **Partial Proof-Test** and follow the on-screen instructions.

⁽¹⁾ Available on Rosemount 2140 version of the level detector only.

6.5.2 Start the local partial proof test

By default, the partial proof testing sequence is not started at every power-up. It can be started by an operator using the Local Operator Interface (LOI).

Procedure

In the menu system, select **TEST** → **PROOF TEST** or, when no LOI is not fitted, by using the single external push-button fitted to the top of the level detector (underneath the movable nameplate).

6.5.3 Configure the proof test function

Procedure

1. Select **Configure** → **Manual Setup** → **Operation** → **Proof Test**.
2. Set the **Duration** as desired.
3. In the *Start-up Proof-Test* list, select **Enabled** or **Disabled**.

Configure proof test function using the LOI

Procedure

1. Press any LOI configuration button to activate the menu.
2. Scroll down (↓) and then select **EXTENDED MENU** (↵).
3. Scroll down (↓) and then select **PROOF TEST** (↵).
4. Choose the proof-test parameter to change:
 - a) Select **DURATION** for setting how long the partial proof-test lasts.
 - b) Select **START-UP** for setting if partial proof-testing at start-up is enabled or disabled
5. Exit the menu system by either waiting one minute for the **EXIT MENU?** prompt, or scrolling down menus to find and select **BACK TO MENU** and **EXIT MENU**.

Duration of the proof test routine

The Proof-Test Duration parameter determines the duration of the whole partial proof-testing sequence.

Four steps performed are:

- Low Alarm Current step
 - The analog output current is overridden to the Low Alarm level (as configured).
- Off Current step
 - The analog output current is overridden to the level of the 'off' switched output state (as configured).
- On Current step
 - The analog output current is overridden to the level of the 'on' switched output state (as configured).

- High Alarm Current step
 - The analog output current is overridden to the High Alarm level (as configured).

Note

Setting a value of “0 s” (zero seconds) results in the analog output not being exercised during the proof-test. Only a diagnostic check of the device is performed in this case.

7 Service and troubleshooting

7.1 Safety messages

Instructions and procedures in this section may require special precautions to ensure the safety of the personnel performing the operations. Information that potentially raises safety issues is indicated by a warning symbol () . Refer to the following safety messages before performing an operation preceded by this symbol.

WARNING

Failure to follow safe installation and servicing guidelines could result in death or serious injury.

Ensure the level detector is installed by qualified personnel and in accordance with applicable code of practice.

Use the level detector only as specified in this manual. Failure to do so may impair the protection provided by the level detector.

The weight of a level detector with a heavy flange and extended fork length may exceed 37 lb. (18 kg). A risk assessment is required before carrying, lifting, and installing the level detector.

For installations in hazardous locations, the level detector must be installed according to the Rosemount 2140 and 2140:SIS Level Detectors [Product Certifications](#) document.

Repair, e.g. substitution of components, etc. may jeopardize safety and is under no circumstances allowed.

WARNING

Explosions could result in death or serious injury.

Verify that the operating atmosphere of the level detector is consistent with the appropriate hazardous locations certifications.

Before connecting a handheld communicator in an explosive atmosphere, ensure that the instruments in the loop are installed in accordance with intrinsically safe or non-incendive field wiring practices.

In explosion-proof/flameproof and non-incendive installations, do not remove the housing covers when power is applied to the level detector.

Both housing covers must be fully engaged to meet flameproof/explosion-proof requirements.

⚠ WARNING**Electrical shock could cause death or serious injury.**

Avoid contact with the leads and terminals. High voltage that may be present on leads can cause electrical shock.

Ensure the power to the level detector is off, and the lines to any other external power source are disconnected or not powered while wiring the level detector.

Ensure the wiring is suitable for the electrical current and the insulation is suitable for the voltage, temperature, and environment.

⚠ WARNING**Process leaks could result in death or serious injury.**

Ensure the level detector is handled carefully. If the process seal is damaged, gas might escape from the vessel (tank) or pipe.

⚠ WARNING**Physical access**

Unauthorized personnel may potentially cause significant damage to and/or misconfiguration of end users' equipment. This could be intentional or unintentional and needs to be protected against.

Physical security is an important part of any security program and fundamental to protecting your system. Restrict physical access by unauthorized personnel to protect end users' assets. This is true for all systems used within the facility.

⚠ CAUTION**Hot surfaces**

The flange and process seal may be hot at high process temperatures. Allow to cool before servicing.



7.2 Diagnostic messages

The diagnostic messages in this section are organized according to the four NAMUR NE 107 alert categories. NE 107 is used when operating in HART 7 mode.

For HART5 devices, the descriptions and recommended actions are the same, but the alerts are mapped to the three Plantweb™ alerts categories.

7.2.1 Failure

Electronics board failure

Category	Failure – Fix Now
LOI screen	FAIL BOARD

Cause

A failure has been detected in the electronics circuit board.

Recommended actions

1. Reset the device.
2. If the condition persists, contact your local Emerson representative.

Related information

[Reset the device](#)

Memory error

Category	Failure – Fix Now
LOI screen	MEMORY ERROR

Cause

A fault has been detected in the non-volatile memory of this device.

Recommended actions

1. Reconfirm all configuration items of the device.
2. Reset the device.
3. If the condition persists, contact your local Emerson representative.

Related information

[Reset the device](#)

Sensor error

Category	Failure – Fix Now
LOI screen	SENSOR ERROR

Cause

A fault has been detected in the vibrating fork sensor. This may be due to serious corrosion, coating, physical damage or an internal fault.

Recommended actions

1. Inspect the fork sensor for damage and clean if necessary.
2. If the condition persists, contact your local Emerson representative.

7.2.2 Function check

Analog output fixed

Category	Function Check
LOI screen	ANALOG FIXED

Cause

The analog output is fixed and does not represent the process measurement. This may be caused by other conditions in the device, or because the device has been set to loop test or multidrop mode.

Recommended actions

1. Take action on any other notifications from the device.
2. If the device is in loop test, and should no longer be, disable or momentarily remove power.
3. If the device is in multidrop mode and should not be, re-enable loop current by setting the polling address to 0.

Related information

[Loop testing](#)

[HART polling address](#)

Partial proof test active

Category	Function Check
LOI screen	PROOFTST ACTIVE

Cause

Partial proof test has been activated either on start-up or manually.

Recommended actions

1. Verify that start-up partial proof test is no longer required.
2. Set **Start-up Proof-Test** to **Disabled**.

Related information

[Configure the proof test function](#)

Simulation active

Category	Function Check
LOI screen	[None]

Cause

The device is in simulation mode and may not be reporting actual information.

Recommended actions

1. Verify that simulation is no longer required.
2. Disable simulation mode in **Service Tools**.
3. Perform a device reset.

Related information

[Simulation mode](#)
[Reset the device](#)

7.2.3 Out of specification

Electronics temperature out of limits

Category	Out of Specification – Fix Soon
LOI screen	TEMP OUT LIMITS

Cause

The instrument electronics temperature is outside the operating range of the device.

Recommended actions

1. Check the ambient temperature conditions are within limits.
2. If the condition persists, contact your local Emerson representative.

Related information

[Maximum and minimum operating temperatures](#)

Supply voltage low

Category	Out of Specification – Fix Soon
LOI screen	SUPPLY L

Cause

The supply voltage of this device is getting close to the failure limit.

Recommended actions

1. Check the power supply.
2. If the condition persists, contact your local Emerson representative.

Related information

[Power supply](#)

Power advisory diagnostic

Category	Out of Specification – Fix Soon
LOI screen	POWER ADVISE

Cause

The level detector has detected a deviation of the terminal voltage outside of configured limits. This may indicate degraded electrical or loop integrity.

Recommended actions

1. Check the dc power supply to make sure the power is correct, stable, and has minimal ripple.
2. Check the loop wiring for degradation or improper grounding.
3. Remove the wiring compartment cover (considering hazardous location requirements) to check for presence of water or corrosion.
4. Re-characterize loop and adjust alert thresholds if necessary.
5. If conditions have resumed to normal, select **Reset Alert** to clear the alert.

Related information

[Power advisory](#)

Frequency out of limits

Category	Out of Specification – Fix Soon
LOI screen	FREQ LIMITS

Cause

The sensor frequency is beyond the operating range of the fork sensor.

Recommended actions

1. Check the condition of the fork sensor.
2. Reset the device.
3. If the condition persists, contact your local Emerson representative.

Related information

[Reset the device](#)

Output state alert

Category	Out of Specification – Fix Soon
LOI screen	OUTPUT ALERT

Cause

The output state has gone beyond the configured trip points.

Recommended actions

Verify that the configuration of the trip points is as intended and expected.

Related information

[Alert setup](#)

Sensor state alert

Category	Out of Specification – Fix Soon
LOI screen	SENSOR ALERT

Cause

The sensor state has gone beyond the configured trip points.

Recommended actions

Verify that the configuration of the trip points is as intended and expected.

Related information

[Alert setup](#)

Sensor frequency alert

Category	Out of Specification – Fix Soon
LOI screen	FREQ ALERT

Cause

The sensor frequency has gone beyond the configured trip points.

Recommended actions

Verify that the configuration of the trip points is as intended and expected.

Related information

[Alert setup](#)

Scaled variable alert

Category	Out of Specification – Fix Soon
LOI screen	SCALED ALERT

Cause

The scaled variable has gone beyond the configured trip points.

Recommended actions

Verify that the configuration of the trip points is as intended and expected.

Related information

[Scaled variable](#)
[Alert setup](#)

Terminal voltage alert

Category	Out of Specification – Fix Soon
LOI screen	VOLTAGE ALERT

Cause

The terminal voltage has gone beyond the configured trip points.

Recommended actions

Verify that the configuration of the trip points is as intended and expected.

Related information

[Alert setup](#)

Electronics temperature alert

Category	Out of Specification – Fix Soon
LOI screen	TEMPERAT ALERT

Cause

The electronics temperature has gone beyond the configured trip points.

Recommended actions

Verify that the configuration of the trip points is as intended and expected.

Related information

[Alert setup](#)

Analog output saturated

Category	Out of Specification – Fix Soon
LOI screen	ANALOG SAT

Cause

The analog output is saturated either high or low due to the Primary Variable (PV) either above or below the range values.

Recommended actions

Check the PV applied to ensure it is between the 4-20 mA points.

Related information

[Alarm and saturation levels](#)

7.2.4 Maintenance required

Memory warning

Category	Maintenance Required
LOI screen	MEMORY WARN

Cause

A fault has been detected in the non-volatile memory of this device.

Recommended actions

1. Reconfirm all configuration items of the device.
2. Reset the device.
3. If the condition persists, contact your local Emerson representative.

Related information

[Reset the device](#)

Stuck key

Category	Maintenance Required
LOI screen	STUCK BUTTON

Cause

One of the keys on the LOI is detected as stuck in the active position.

Recommended actions

1. Check the keys for obstructions.
2. Reset the device.
3. If the condition persists, contact your local Emerson representative.

Sensor frequency unstable

Category	Maintenance Required
LOI screen	FREQ UNSTAB

Cause

Frequency Profiling has detected an unstable sensor frequency.

Recommended actions

1. Check the condition of the sensor.
2. Reset the alert.
 - a) Select **Configure** → **Manual Setup** → **Frequency Profiling**.
 - b) Select **Reset Frequency Alert** and follow the on-screen instructions.
3. If the condition persists, contact your local Emerson representative.

Related information

[Frequency profiling](#)

Device display update failure

Category	Maintenance Required
LOI screen	[If display is not updating]

Cause

The device display is not receiving updates from the fork sensor.

Recommended actions

1. Check the connection between the device display and the circuit board.
2. Replace the device display.

7.3 Troubleshooting the 4-20 mA/HART Output

7.3.1 Device milliamp reading is zero

Recommended actions

1. Verify power is applied to signal terminals.
2. Verify power supply voltage is adequate at signal terminals.
3. Check power wires for reversed polarity.
4. Verify device and power supply are properly grounded.
5. Check for open diode across test terminal.

7.3.2 Device is not communicating with handheld communicator

Recommended actions

1. Verify power supply voltage is adequate at signal terminals.
2. Check load resistance (250 ohms minimum).
3. Check that power wires are connected to signal terminals and not test terminals.
4. Verify clean DC Power to level detector (Max AC noise 0.2 volts peak to peak).
5. Verify the output is between 4 and 20 mA or saturation levels.
6. Have handheld communicator poll for all addresses.

7.3.3 Device milliamp reading is too low or high

Recommended actions

1. Check the settings of the 4-20 mA range values.
2. Verify output is not in alarm condition.
3. Check that power wires are connected to the correct signal terminals.
4. Perform Calibrate Analog Out.

7.3.4 Milliamp reading is erratic

Recommended actions

1. Verify power supply voltage is adequate at signal terminals.
2. Check for external electrical interference.
3. Verify device is properly grounded.
4. Verify shield for twisted pair is only grounded at one end.

7.4 Service and troubleshooting tools

7.4.1 Diagnostic information

View diagnostics

Procedure

Select **Service Tools** → **Maintenance** → **Diagnostics**.

Sensor frequency

The vibrating fork frequency is indicated in the read-only Sensor Frequency device variable after sensor compensation has been applied.

Sensor state

This is a read-only variable and indicates the present state of the vibrating fork sensor.

As the vibrating fork sensor becomes immersed in a process liquid, the vibration frequency decreases and the sensor state changes to a 'wet state' at the detection point.

When a process liquid falls away from the fork, the vibration frequency increases and the sensor state changes to a 'dry state' at a detection point.

Sensor status

This is a read-only variable. It indicates if the level detector is operating in a valid or fault state.

The Sensor Status is dependent on the configuration of Sensor State and Sensor Operation Mode.

Sensor status logic

Table 7-1: Normal Mode

Sensor status	Sensor state ⁽¹⁾	Current output operating mode	PV (output state)
Valid	Dry	Wet on	Off (0.0)
Valid	Dry	Dry on	On (1.0)
Valid	Wet	Wet on	On (1.0)
Valid	Wet	Dry on	Off (0.0)

(1) Sensor Fault Delay does not delay the update of Sensor State when the operation mode is Normal.

Note

If the operation mode is Normal, Sensor State cannot indicate Too Dry, Too Wet, or Zero, and the Sensor Status always indicates a Valid state.

Table 7-2: Enhanced Mode, Fault = Wet

Sensor status	Sensor state ⁽¹⁾	Current output operating mode	PV (output state)
Valid	Dry	Wet on	Off (0.0) ⁽²⁾
Valid	Dry	Dry on	On (1.0) ⁽²⁾
Fault	Too Dry	Wet on	On (1.0) ⁽³⁾
Valid	Wet	Wet on	On (1.0) ⁽²⁾
Valid	Wet	Dry on	Off (0.0) ⁽²⁾
Fault	Too Wet	Dry on	On (1.0) ⁽³⁾
Fault	Zero	Wet on	On (1.0) ⁽³⁾

(1) Sensor Fault Delay delays the update of Sensor State when the operation mode is Enhanced.

(2) PV is not changed.

(3) PV is automatically changed to on (1.0).

Table 7-3: Enhanced Mode, Fault = Dry

Sensor status	Sensor state ⁽¹⁾	Current output operating mode	PV (output state)
Valid	Dry	Wet on	Off (0.0) ⁽²⁾
Valid	Dry	Dry on	On (1.0) ⁽²⁾
Fault	Too Dry	Wet on	Off (0.0) ⁽³⁾
Valid	Wet	Wet on	On (1.0) ⁽²⁾
Valid	Wet	Dry on	Off (0.0) ⁽²⁾
Fault	Too Wet	Wet on	Off (0.0) ⁽³⁾
Fault	Zero	Wet on	Off (0.0) ⁽³⁾

(1) Sensor Fault Delay delays the update of Sensor State when the operation mode is Enhanced.

(2) PV is not changed.

(3) PV is automatically changed to off (0.0).

Calibration frequencies and switch points

The switching points for Sensor State transitions are determined from these read-only frequencies:

Table 7-4: Calibration Frequencies and Switch Points

Term	Description
Dry fork frequency	This is the frequency recorded when the Rosemount 2140 was calibrated in dry conditions. The frequency is typically 1260 to 1500 Hz. The default dry fork frequency is established at the point of manufacture. However, it can be re-established by using the dry fork calibration procedure when the level detector is installed in a working environment. The dry fork frequency is also used by the Media Density and Media Learn functions.
Wet for frequency	When performing Media Learn the fork frequency used to derive the Media Density value is recorded as the wet fork frequency.
Dry to too dry	Above this upper limit, a measured frequency is considered to be a fault by being outside of the normal dry fork range. The level detector must be operating in Enhanced Mode if this fault is to be indicated in the Sensor Status variable.
Dry to indeterminate	Above this upper limit, a measured frequency is not yet considered to be a fault but is close to being outside of the normal dry fork range.
Wet to indeterminate	Below this lower limit, a measured frequency is not yet considered to be a fault but is close to being outside of the normal wet fork range.
Wet to too wet	Below this lower limit, a measured frequency is considered to be a fault by being outside of the normal wet fork range. The level detector must be operating in Enhanced Mode if this fault is to be indicated in the Sensor Status variable.
Zero	Below this low limit, a measured frequency is considered to be 0 Hz and a fault. The level detector must be operating in Enhanced Mode if this fault is to be indicated in the Sensor Status variable. Note When the level detector is operating in Normal Mode, a 0 Hz sensor frequency represents a Wet condition (and not a fault). When operating in Enhanced Mode, a 0 Hz sensor frequency represents a fault condition.

7.4.2 Reset the device

The function is used to reset the electronics without re-cycling the power. It preserves the user-configuration.

Procedure

1. Select **Service Tools** → **Maintenance** → **Reset/Restore**.
2. Select **Device Reset** and follow the on-screen instructions.

7.4.3 Reset to factory settings

The function resets the user-configuration to the ex-factory settings.

Procedure

1. Select **Service Tools** → **Maintenance** → **Reset/Restore**.
2. Select **Factory Reset** and follow the on-screen instructions.

7.4.4 Dry fork calibration

This command starts the on-site calibration of the fork sensor in dry process conditions. It should only be performed by authorized persons.

A comparison is made between the live fork sensor frequency measured in dry process conditions and original factory-set Dry Fork Frequency value.

If the difference is greater than Allowable Change In Dry Fork Frequency, the re-calibration is rejected. Check the fork for damage, corrosion, or coating, and clean it if necessary before re-trying.

When the calibration is successful, Dry Fork Frequency is set to the new dry frequency.

Related information

[Allowable change in dry fork frequency](#)

Start the dry fork calibration

Procedure

1. Select **Service Tools** → **Maintenance** → **Calibrate Sensor**.
2. Under **Sensor Calibration**, select **Calibrate Dry Fork** and follow the on-screen instructions to perform the dry fork calibration.

Start the dry fork calibration using the LOI

Procedure

1. Press any LOI configuration button to activate the menu.
2. Scroll down (↓) and then select **EXTENDED** (↵).
3. Select **CALIBRATE** (↵).
4. Select **SENSOR CAL** (↵).
5. Follow on-screen instructions to perform the dry fork calibration.
6. Exit the menu system by either waiting one minute for the **EXIT MENU?** prompt, or scrolling down menus to find and select **BACK TO MENU** and **EXIT MENU**.

Restore factory calibration

This command restores the factory calibration of the fork sensor in dry process conditions. It is accessible after a site calibration has been performed, but should only be performed by authorized persons.

Procedure

1. Select **Service Tools** → **Maintenance** → **Calibrate Sensor**.
2. Under **Reset Sensor Calibration**, select **Restore Factory Calibration** and follow the on-screen instructions.

Restore factory calibration using the LOI

This command restores the factory calibration of the fork sensor in dry process conditions. It is accessible after a site calibration has been performed, but should only be performed by authorized persons.

Procedure

1. Press any LOI configuration button to activate the menu.
2. Scroll down (↓) and then select **EXTENDED MENU** (↵).
3. Select **CALIBRATE** (↵).
4. Scroll down (↓) and then select **PARAMETR RECALL** (↵).
5. Select **DRY RECALL CAL** (↵).
6. Follow on-screen instructions to restore the dry fork calibration to factory settings.
7. Exit the menu system by either waiting one minute for the **EXIT MENU?** prompt, or scrolling down menus to find and select **BACK TO MENU** and **EXIT MENU**.

Sensor calibration status

Sensor Calibration Status indicates:

Status	Description
Factory calibrated	No further calibration is normally required.
Site calibrated	Calibration successfully performed on-site.
Un-calibrated	Calibration is required. Contact the factory.

Related information

[Dry fork calibration](#)

7.4.5 Calibrate analog output

Use this function to calibrate the analog output by comparing the actual output current with the nominal 4 mA and 20 mA currents.

Prerequisites

Calibration is done at factory and the analog output does not normally need to be recalibrated.

A reference meter (ammeter) is required for measuring the actual output current at 4 mA and 20 mA. If a resistor is added to the loop, ensure that the power supply is sufficient to power the level detector to a 20 mA output with that additional loop resistance.

Procedure

1. Select **Service Tools** → **Maintenance** → **Calibrate Analog**.
2. Select **Calibrate** and follow the on-screen instructions.

Calibrate analog output using the LOI

Use this function to calibrate the analog output by comparing the actual output current with the nominal 4 mA and 20 mA currents. Calibration is done at factory and the analog output does not normally need to be recalibrated.

Prerequisites

A reference meter (ammeter) is required for measuring the actual output current at 4 mA and 20 mA. If a resistor is added to the loop, ensure that the power supply is sufficient to power the level detector to a 20 mA output with that additional loop resistance.

Procedure

1. Press any LOI configuration button to activate the menu.
2. Scroll down (↓) and then select **EXTENDED MENU** (↵).
3. Select **CALIBRATE** (↵).
4. Scroll down (↓) and then select **ANALOG TRIM**.
5. Follow on-screen instructions to perform the calibration of 4 mA and 20 mA.
6. Exit the menu system by either waiting one minute for the **EXIT MENU?** prompt, or scrolling down menus to find and select **BACK TO MENU** and **EXIT MENU**.

7.4.6 Loop testing

Note

This test function is separate from the partial proof-test and does affect the actual output current.

It is considered good practice for the 'on' and 'off' current levels, and alarm level, to be verified when installing, repairing, or replacing a level detector.

The loop test verifies the analog output of the level detector, the integrity of the loop, and the operations of any recorders or similar devices installed in the loop.

The host system may provide a current measurement for the 4-20 mA HART output. If not, connect a reference meter (ammeter) to the level detector by either connecting the meter to the test terminals on the terminal block, or shunting level detector power through the meter at some point in the loop.

This loop test simulation temporarily overrides the analog output with a fixed level of current. Options are:

- 4 mA
- 20 mA

- Simulate alarm
- Other (custom mA)

Start a loop test

Procedure

1. Select **Service Tools** → **Simulate**.
2. Select **Loop test** and follow the on-screen instructions.

Start a loop test using a LOI

Procedure

1. Press any LOI configuration button to activate the menu.
2. Scroll down (↓) and then select **TEST** (↵).
3. Scroll down (↓) and then select **LOOP TEST** (↵).
4. Select **SET 4MA**, **SET 20MA**, or **SET CUSTOM**.
5. Follow on-screen instructions to perform the loop test.
6. Exit the menu system by either waiting one minute for the **EXIT MENU?** prompt, or scrolling down menus to find and select **BACK TO MENU** and **EXIT MENU**.

7.4.7 Simulation mode

Simulation mode is only available in HART Revision 7 mode. In HART 7, some device variables can be set to a temporary value for testing purposes. After the simulation is exited, the device variable is automatically returned to a live value.

Table 7-5: Simulation Mode Options

Device variable	Description
Output State	The Output State device variable can be temporarily overridden to be 'off' or 'on'.
Sensor State	The Sensor State device variable can be temporarily overridden to be 'dry' or 'wet'.
Sensor Frequency	The Sensor Frequency device variable can be temporarily overridden with an entered frequency in the range 0 to 3000 Hz.
Scaled Variable (if supported)	The Scaled Variable device variable can be temporarily overridden with an entered value.
Electronics Temperature	The Electronics Temperature device variable can be temporarily overridden with an entered value.
Terminal Voltage	The Terminal Voltage device variable can be temporarily overridden with an entered voltage value.

Note

Simulations are canceled by exiting a screen. They also be cleared by a power re-cycle or device reset.

Start a simulation

Procedure

1. Select **Service Tools** → **Simulate**.
2. Select a device variable to be used for the simulation.
3. Follow on-screen instructions to perform the simulation.

Start a simulation using the LOI

Procedure

1. Press any LOI configuration button to activate the menu.
2. Scroll down (↓) and then select **EXTENDED MENU** (↵).
3. Scroll down (↓) and then select **SIMULATE** (↵).
4. Scroll down (↓) and then select (↵) a device variable.
5. Follow on-screen instructions to perform the simulation.
6. Exit the menu system by either waiting one minute for the **EXIT MENU?** prompt, or scrolling down menus to find and select **BACK TO MENU** and **EXIT MENU**.

7.4.8 Adjust sensor compensation

The frequency of the vibrating fork sensor may be affected by a process temperature being different to the calibrated temperature. Entering a known process temperature can compensate accordingly and provide an improved frequency switching point.

Procedure

1. Select **Service Tools** → **Maintenance** → **Calibrate Sensor**.
2. Under **Sensor Compensation**, enter the known **Process Temperature**.

7.5 Opening the lid (cover)

Before opening the lid for maintenance reasons observe following items:

- Do not remove the lid while circuits are live.
- No dust deposits or whirlings are present.
- No rain can enter into the housing.

7.6 Service support

To expedite the return process outside of the United States, contact the nearest Emerson representative.

Within the United States, call the Emerson Instrument and Valve Response Center using the 1-800-654-RSMT (7768) toll-free number. This center, available 24 hours a day, will assist you with any needed information or materials.

The center will ask for product model and serial numbers, and will provide a Return Material Authorization (RMA) number. The center will also ask for the process material to which the product was last exposed.

⚠ CAUTION

Individuals who handle products exposed to a hazardous substance can avoid injury if they are informed of and understand the hazard. Returned products must include a copy of the required Safety Data Sheet (SDS) for each substance.

Emerson Instrument and Valve Response Center representatives will explain the additional information and procedures necessary to return goods exposed to hazardous substances.

A Specifications and reference data

A.1 General

A.1.1 Measuring technology

Vibrating fork

A.1.2 Applications

Point level detection in liquid process mediums, including coating liquids, aerated liquids, and slurries. Suitable for horizontal and vertical installation.

A.2 Functional safety

The Rosemount 2140:SIS is IEC 61508 certified to:

- Type B low-demand device
- SIL 2 @ HFT = 0
- SIL 3 @ HFT = 1

Related information

[Functional Safety Certificate](#)
[Rosemount 2140:SIS Safety Manual](#)

A.3 Performance specifications

A.3.1 Hysteresis (water)

0.1 in. (2.5 mm)

A.3.2 Switching point (water)

0.5 in. (13 mm) from fork tip if mounted vertically.

0.5 in. (13 mm) from the fork edge if mounted horizontally.

The switching point varies with different liquid densities.

The level detector allows pre-selection of a liquid density range, and has a built-in learning function to make it even easier.

A.3.3 Detection output delay

Optional output delay, programmable from 0 to 3600 seconds, to prevent false detection caused by splashing on the forks. Default delay is 1 second.

A.3.4 Liquid density ranges

There are four field-selectable density options for the level detector to use even more accurate switching points. The default pre-selection is "Standard" and is suitable for most liquids.

- Low (400 to 600 kg/m³)
- Medium (500 to 900 kg/m³)
- Standard (800 to 1300 kg/m³)
- High (1200 to 3000 kg/m³)

A.3.5 Liquid viscosity range

Up to 10000 cP (centiPoise) when operating in the Normal mode.

Up to 1000 cP (centiPoise) when operating in Enhanced mode.

A.4 Electrical specifications

A.4.1 Power supply

10.5 to 42.4 Vdc (with no load)

A.4.2 Output

Digital process variable is superimposed on 4–20 mA signal, available to any host that conforms to HART protocol.

Table A-1: Current Output Availability

Current Output operating types ⁽¹⁾	Rosemount 2140 (profile option code A)	Rosemount 2140:SIS (profile option code F)
8/16 mA HART switched output	Yes	Yes
4/20 mA HART switched output	Yes	Yes
Custom mA HART switched output	Yes	Yes
4–20 mA HART	Yes	No
LEVELTESTER switched output	Yes	Yes

(1) Software selectable.

A.4.3 HART revision

- Revision 5
- Revision 7

The HART revision can be switched in field.

A.4.4 Terminal connection (wire diameter)

Minimum 24 AWG, maximum 14 AWG (0.2 to 2.5 mm²)

A.5 Environmental specifications

A.5.1 Maximum operating pressures

Figure A-1: Operating Pressures

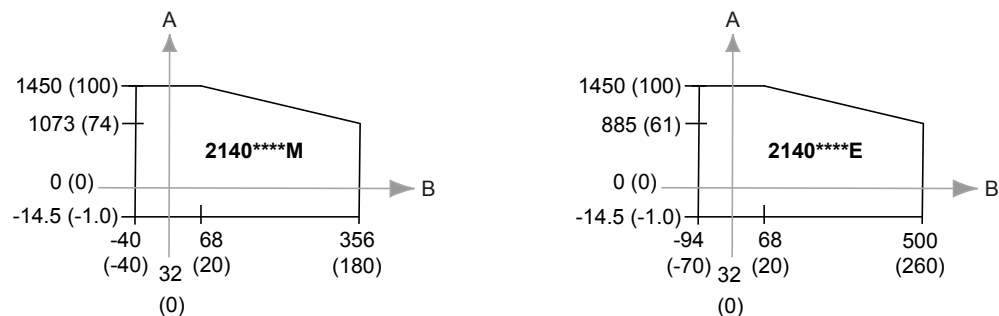

- A. Process pressure, psig (barg)
B. Process temperature, °F (°C)

The final rating depends on the process-wetted connection.

Threaded connection

See [Figure A-1](#).

Tri Clamp connection

435 psig (30 barg)

Flanged connection

The maximum operating pressure is the lower of the process pressure ([Figure A-1](#)) and flange pressure rating (see [Table A-2](#)).

Table A-2: Maximum Flange Pressure Rating

Standard	Class/rating	Stainless steel flanges
ASME B16.5	Class 150	275 psig ⁽¹⁾
ASME B16.5	Class 300	720 psig ⁽¹⁾
ASME B16.5	Class 600	1440 psig ⁽¹⁾
EN1092-1	PN 10/16	16 barg ⁽²⁾
EN1092-1	PN 25/40	40 barg ⁽²⁾
EN1092-1	PN 63	63 barg ⁽²⁾
EN1092-1	PN 100	100 barg ⁽²⁾
JIS B2220	10K	14 barg ⁽³⁾
JIS B2220	20K	34 barg ⁽³⁾
Mobrey A flange	Not applicable	33 bar
Mobrey G flange	Not applicable	21 bar

- (1) At 100 °F (38 °C), the pressure rating decreases with an increasing process temperature.
 (2) At 122 °F (50 °C), the pressure rating decreases with an increasing process temperature.
 (3) At 248 °F (120 °C), the rating decreases with an increasing process temperature.

A.5.2 Maximum and minimum operating temperatures

See [Figure A-2](#) for the maximum and minimum operating temperatures.

Figure A-2: Operating Temperatures

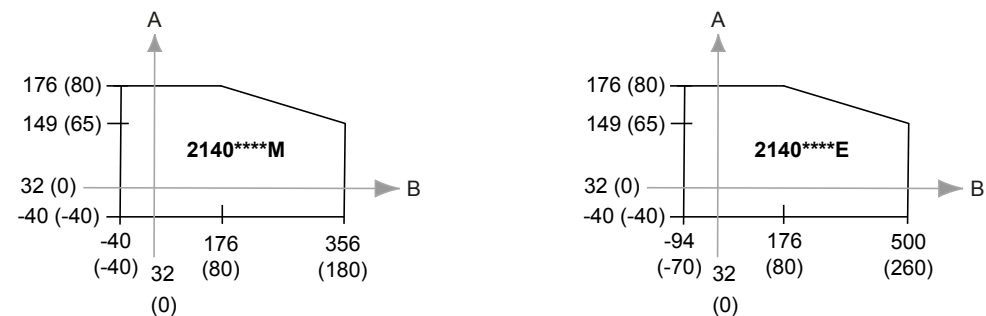

- A. Ambient Temperature, °F (°C)
 B. Process Temperature, °F (°C)

See the Rosemount 2140 [Product Certifications](#) document for operating temperature limits required by approvals.

A.6 Physical specifications

A.6.1 Material selection

Emerson provides a variety of Rosemount products with various product options and configurations including materials of construction that can be expected to perform well in a wide range of applications. The Rosemount product information presented is intended as a guide for the purchaser to make an appropriate selection for the application. It is the purchaser's sole responsibility to make a careful analysis of all process parameters (such as all chemical components, temperature, pressure, flow rate, abrasives, contaminants, etc.), when specifying product, materials, options, and components for the particular application. Emerson is not in a position to evaluate or guarantee the compatibility of the process fluid or other process parameters with the product, options, configuration or materials of construction selected.

A.6.2 Electronics housing

Housing material

Aluminum alloy ASTM B85 A360.0 or stainless steel (316C)

Rotation

Rotatable housing to allow more convenient cable position.

Local display

Optional two-line LCD display with Local Operator Interface (LOI). There are two internal and two external configuration buttons. Includes extended cover with glass window.

Local proof-test button

The level detector comes with a single external button for local proof testing. This single button is replaced by two configuration buttons when the LCD display with LOI option is selected.

Note

Remote proof-testing is available using a HART command.

Conduit plugs/cable glands

The Rosemount 2140 ships with dust caps installed in the conduit entries. One blanking plug is supplied in a plastic bag, ready to be installed. No cables or cable glands are supplied.

Ingress protection

IP66/67 to EN60529, NEMA® 4X (when supplied blanking plug and suitably rated cable glands are used).

A.6.3 Process wetted connections

Connections

Threaded, Tri Clamp, and flanged process connection options.

Materials

- 316/316L stainless steel (1.4401/1.4404 dual-certified)
Mechanically-polished option to better than 0.1 µm for Tri Clamp connections.
- Alloy C (UNS N10002) and Alloy C-276 (UNS N10276)
Available for flanged, and selected threaded process connections (¾-in. and 1-in. BSPT (R), and ¾-in. and 1-in. NPT).
- ECTFE co-polymer coated 316/316L Stainless Steel (1.4401/1.4404 dual certified)
Available only for flanged process connections, but excludes 1-in./DN25/25A flanges.
- Gasket material for ¾-in. and 1-in. BSPP (G) is non-asbestos BS7531 Grade X carbon fiber with rubber binder.
Gaskets are not supplied with flanged process connections.

A.6.4 Customer specified fork length

Table A-3: Extended Fork Lengths

Process connection	Minimum	Maximum ⁽¹⁾
¾-in. threaded	3.8 in. (95 mm)	157.5 in. (4000 mm)
1-in. threaded	3.7 in. (94 mm)	157.5 in. (4000 mm)
2-in. threaded	3.7 in. (94 mm)	157.5 in. (4000 mm)
Flanged	3.5 in. (89 mm)	157.5 in. (4000 mm)
Tri Clamp	4.1 in. (105 mm)	157.5 in. (4000 mm)

(1) The maximum extended length is 157.5 in. (4000 mm), except for ECTFE co-polymer coating and polished process connection options which have a maximum length of 59.1 in. (1500 mm) and 39.4 in. (1000 mm) respectively.

A.7 Dimensional drawings

Refer to the [Type 1 Drawings](#) on the Rosemount 2140 [web page](#) for dimensions of the O-ring seal (BSPP) versions.

Figure A-3: Housing

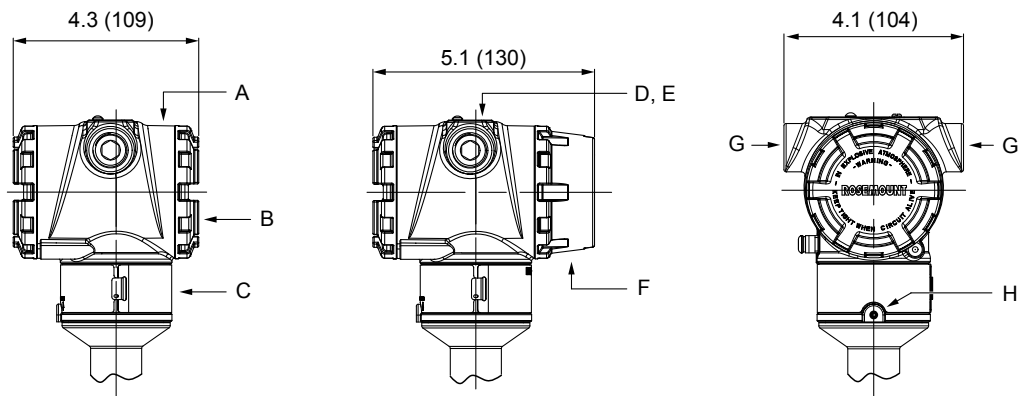

- A. Aluminum or stainless steel housing
- B. No LCD display
- C. Certification plate
- D. Cover plate (with logo, product name, and conduit entry size)
- E. External button(s) under movable plate
- F. LCD display option
- G. Conduit/cable entry M20 x 1.5 or ½-in. ANPT
- H. Housing rotation set screw. Do not unscrew all the way. Rotating the housing, without this screw in place, can damage the internal wiring

Dimensions are in inches (millimeters).

Figure A-4: $\frac{3}{4}$ - and 1-in. Threaded Process Connection (Mid Temperature Range)

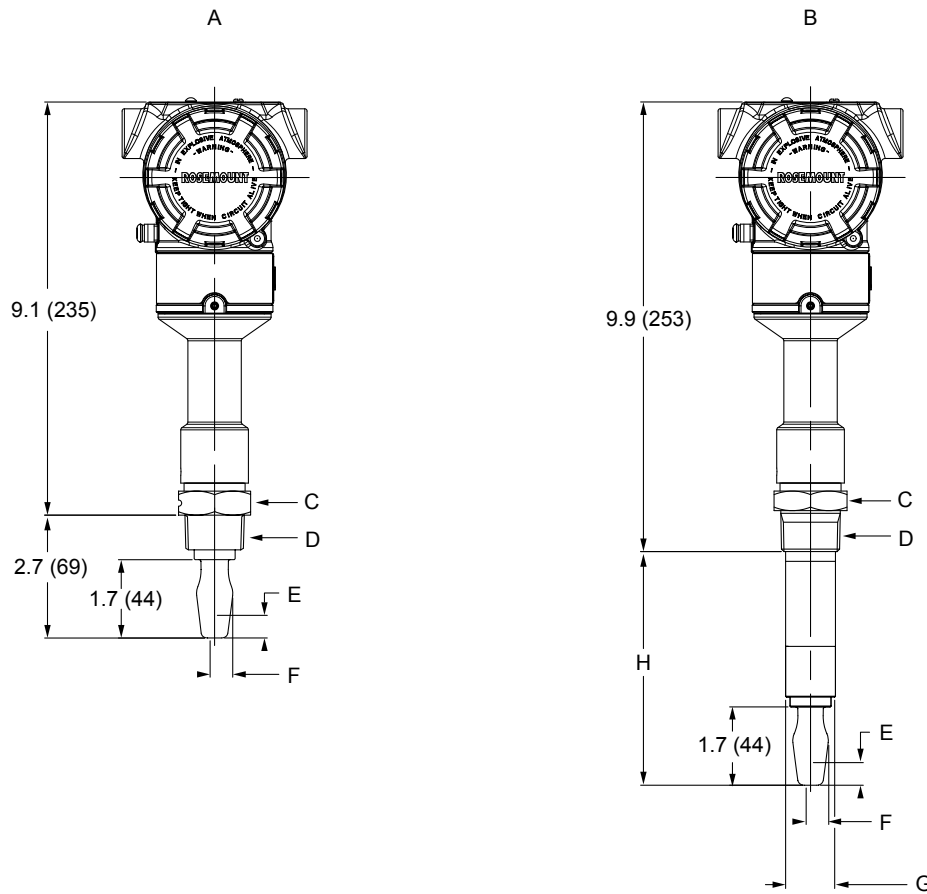

- A. Standard length fork
- B. Extended length fork
- C. 1.6 (40) A/F hexagon
- D. $\frac{3}{4}$ - or 1-in. thread
- E. 0.5 (13) switching point when mounted vertically
- F. 0.5 (13) switching point when mounted horizontally
- G. $\text{\O}1.14$ (29) for 1-in. thread; $\text{\O}0.9$ (23) for $\frac{3}{4}$ -in. thread
- H. Customer specified fork length (see [Table A-3](#))

Dimensions are in inches (millimeters).

Figure A-5: $\frac{3}{4}$ - and 1-in. Threaded Process Connection (High Temperature Range)

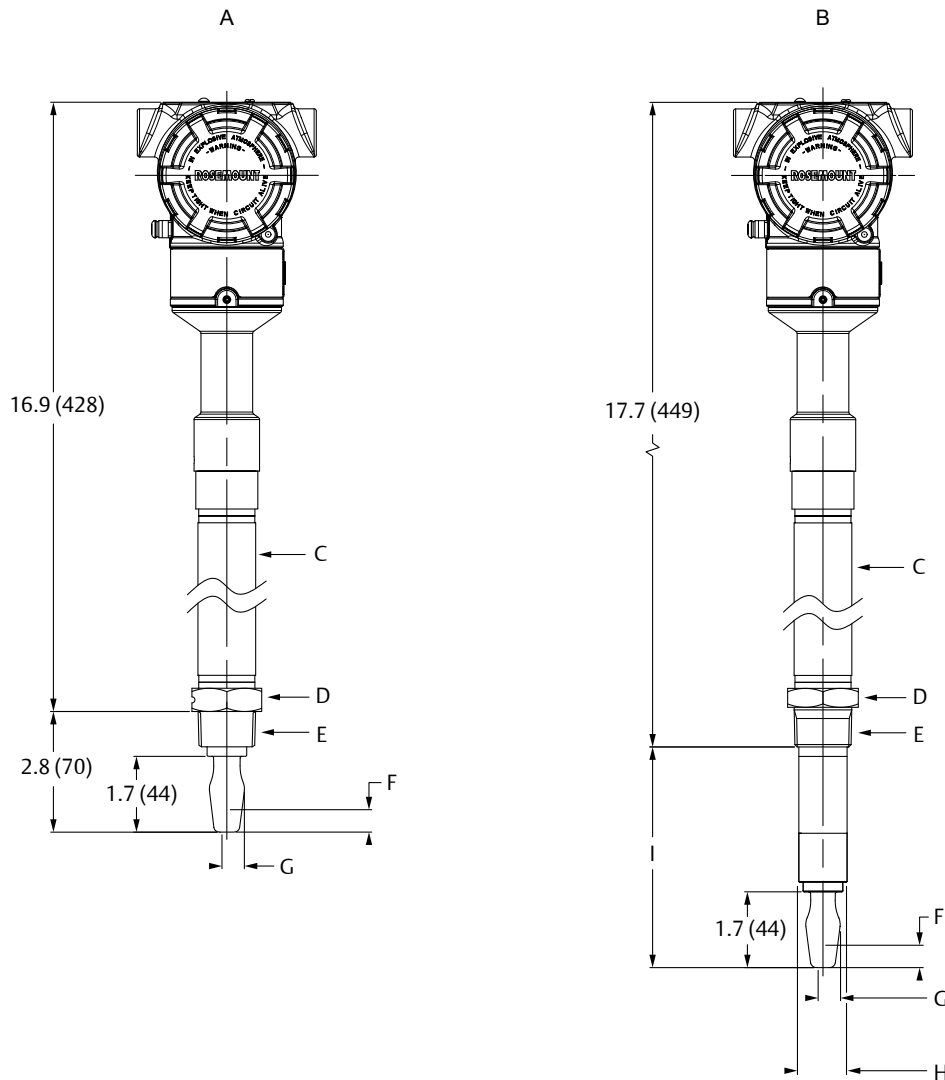

- A. Standard length fork
- B. Extended length fork
- C. Thermal tube
- D. 1.6 (40) A/F hexagon
- E. $\frac{3}{4}$ - or 1-in. thread
- F. 0.5 (13) switching point when mounted vertically
- G. 0.5 (13) switching point when mounted horizontally
- H. $\text{\O}1.14$ (29) for 1-in. thread; $\text{\O}0.9$ (23) for $\frac{3}{4}$ -in. thread
- I. Customer specified fork length (see [Table A-3](#))

Dimensions are in inches (millimeters).

Figure A-6: 2-in. Threaded Process Connection (Mid Temperature Range)

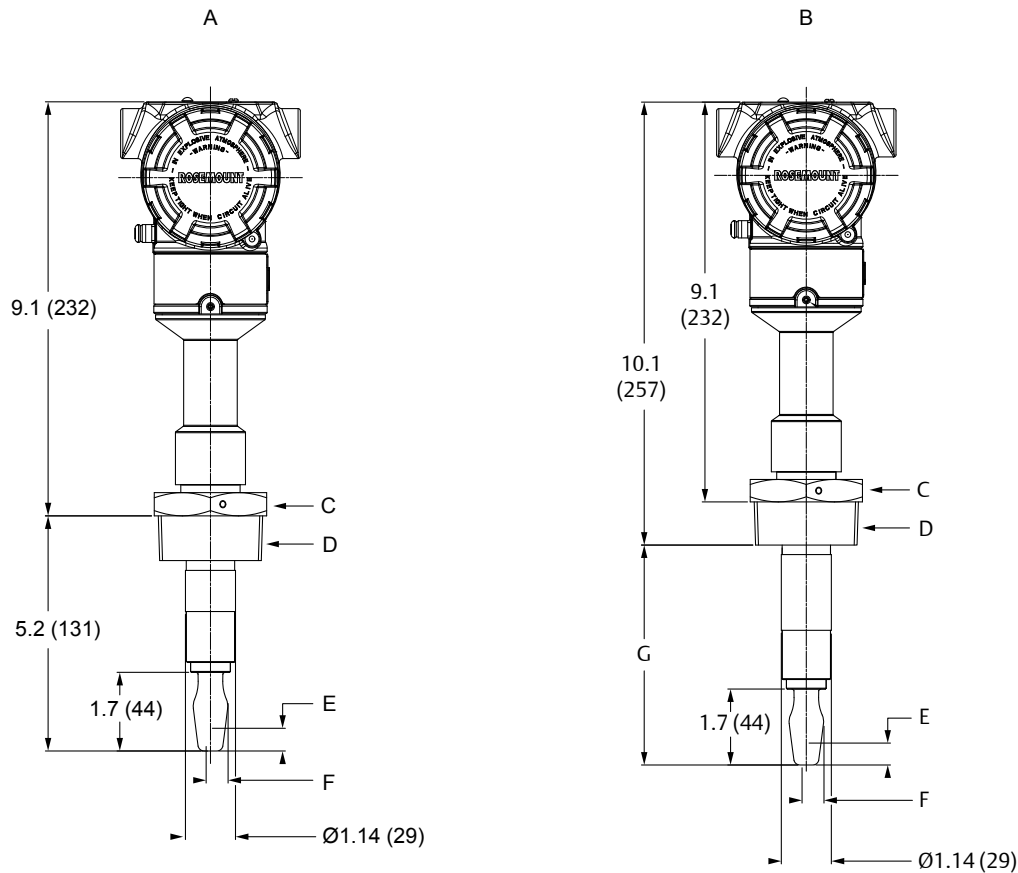

- A. Standard length fork
- B. Extended length fork
- C. 2.6 (65) A/F hexagon
- D. 2-in. thread
- E. 0.5 (13) switching point when mounted vertically
- F. 0.5 (13) switching point when mounted horizontally
- G. Customer specified fork length (see [Table A-3](#))

Dimensions are in inches (millimeters).

Figure A-7: Flanged Process Connection (Mid Temperature Range)

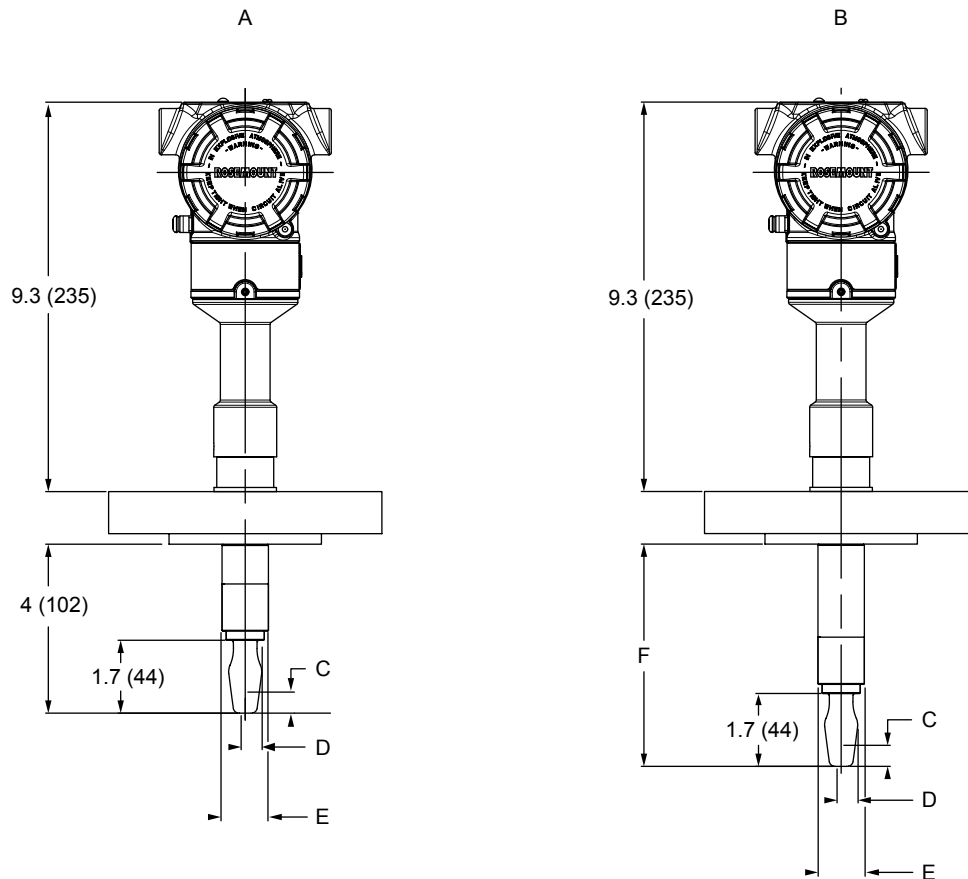

- A. Standard length fork
- B. Extended length fork
- C. 0.5 (13) switching point when mounted vertically
- D. 0.5 (13) switching point when mounted horizontally
- E. $\text{\O}0.9$ (23) for up to 1-in. flange; $\text{\O}0.95$ (24) for up to 1-in. coated flange; $\text{\O}1.14$ (29) for 1½-in. or larger flange
- F. Customer specified fork length (see [Table A-3](#))

Dimensions are in inches (millimeters).

Figure A-8: Flanged Process Connection (High Temperature Range)

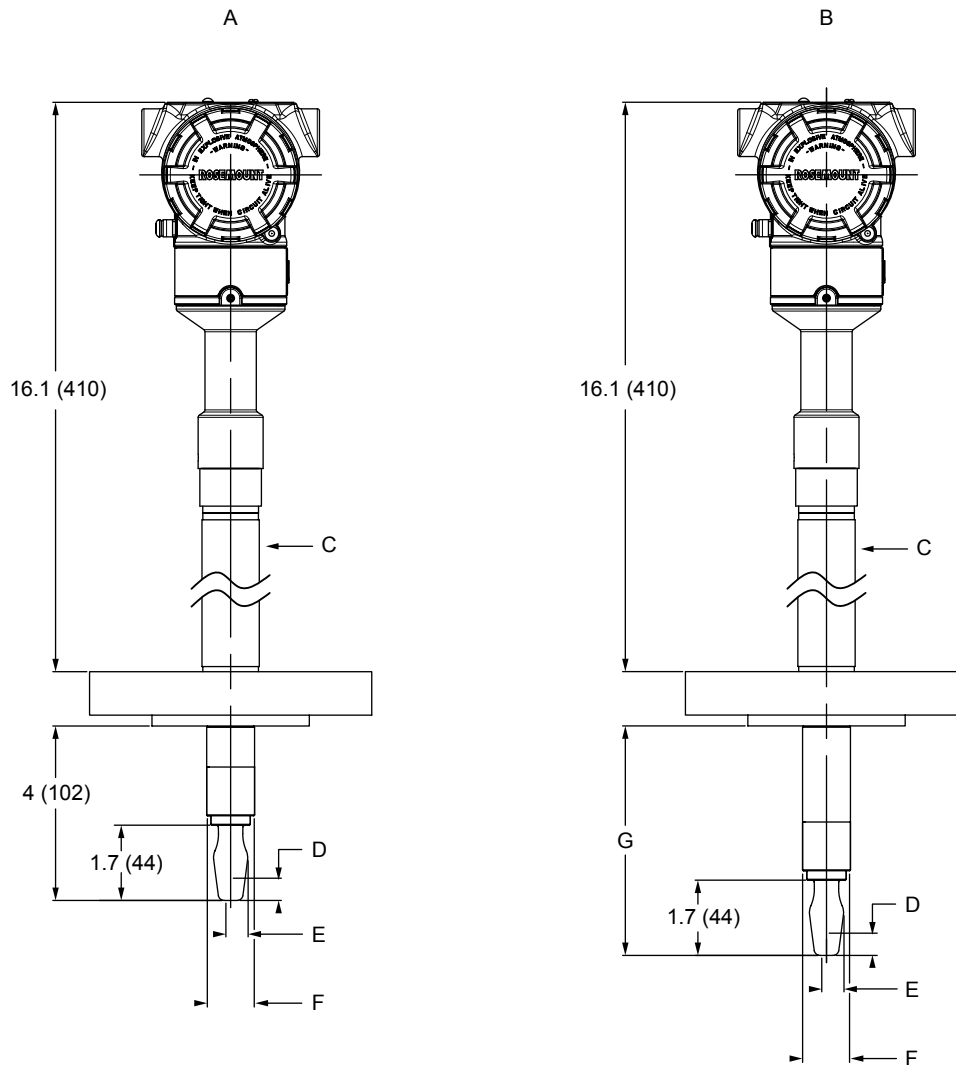

- A. Standard length fork
- B. Extended length fork
- C. Thermal tube
- D. 0.5 (13) switching point when mounted vertically
- E. 0.5 (13) switching point when mounted horizontally
- F. $\text{\O}0.9$ (23) for up to 1-in. flange; $\text{\O}1.14$ (29) for 1½-in. or larger flange
- G. Customer specified fork length (see [Table A-3](#))

Dimensions are in inches (millimeters).

Figure A-9: Tri Clamp Process Connection (Mid Temperature Range)

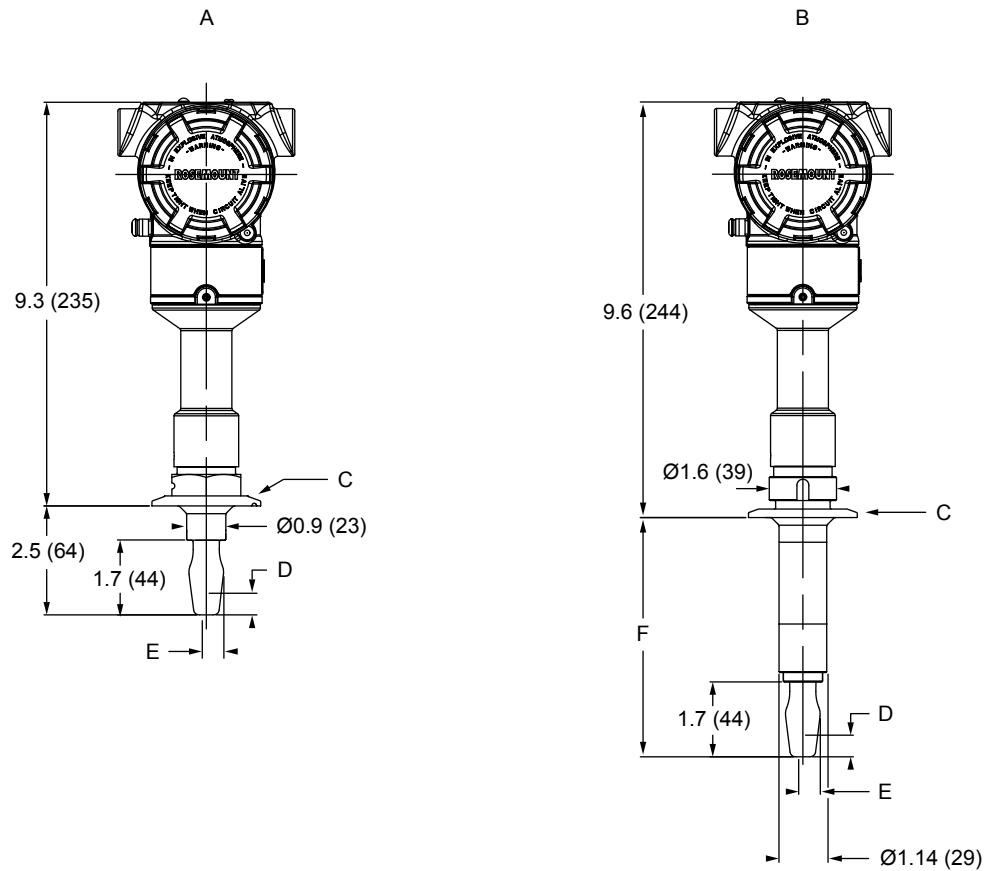

- A. Standard length fork
- B. Extended length fork
- C. 1½- or 2-in. Tri Clamp
- D. 0.5 (13) switching point when mounted vertically
- E. 0.5 (13) switching point when mounted horizontally
- F. Customer specified fork length (see [Table A-3](#))

Dimensions are in inches (millimeters).

Figure A-10: Tri Clamp Process Connection (High Temperature Range)

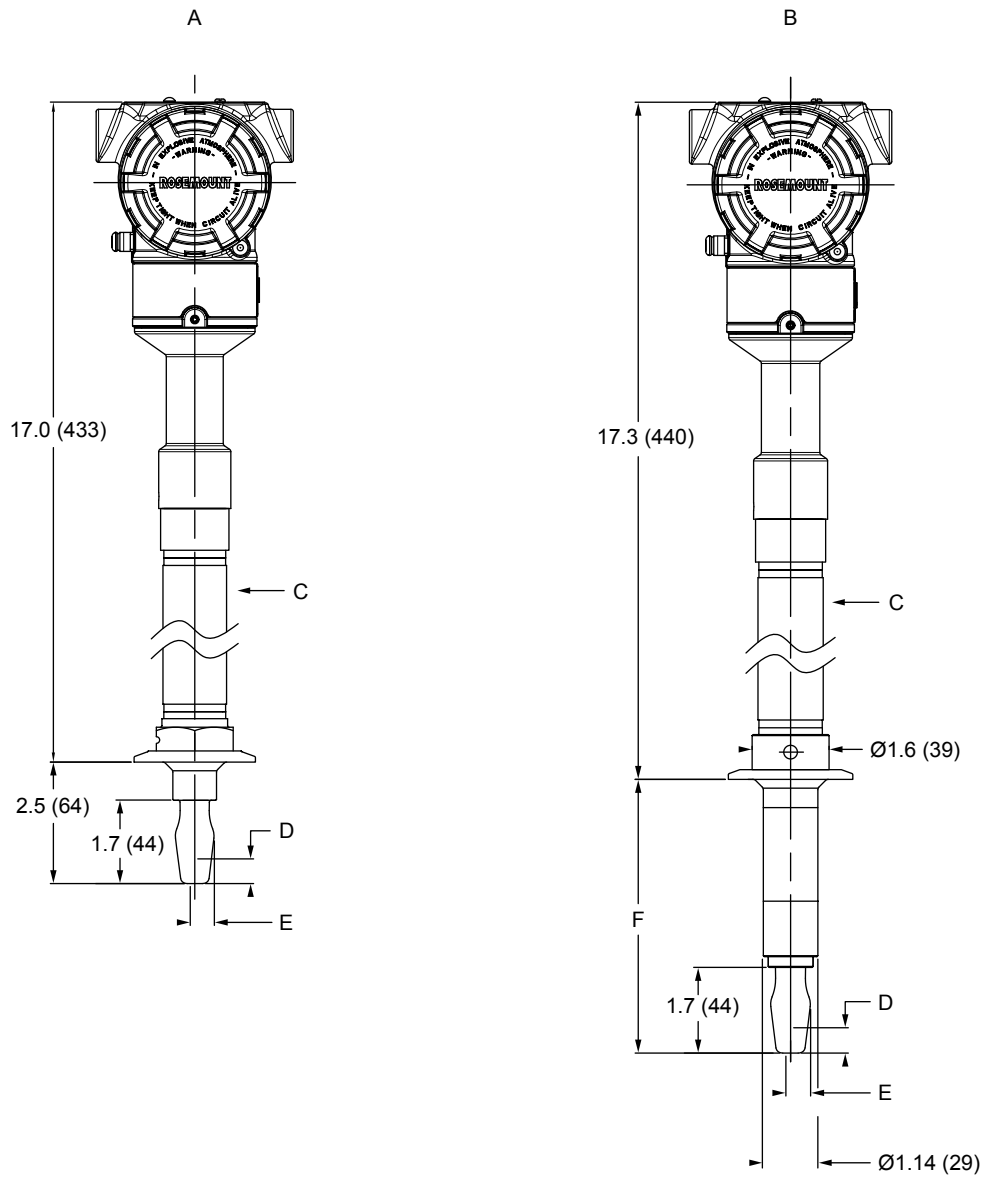

- A. Standard length fork
- B. Extended length fork
- C. Thermal tube
- D. 0.5 (13) switching point when mounted vertically
- E. 0.5 (13) switching point when mounted horizontally
- F. Customer specified fork length (see [Table A-3](#))

Dimensions are in inches (millimeters).

B Configuration parameters

B.1 Manual setup

B.1.1 Operation

Sensor operating mode

The level detector has three sensor operating modes:

Table B-1: Sensor Operating Modes

Option	Description
Normal	Sensor fault detection is not enabled. Do not select this option for SIS applications.
Enhanced, Fault=Wet	The level detector is forced to indicate a wet fork in a fail-safe state.
Enhanced, Fault=Dry	The level detector is forced to indicate a dry fork in a fail-safe state.

Sensor output delay

When there is a detected change in process conditions, from wet-to-dry or dry-to-wet, the Sensor Output Delay variable can action a delay of up to 3600 seconds before the change of state is indicated. The default delay is one second.

Depending on the application, a suitable delay can prevent constant switching of the output state. If, for example, there are waves in a tank, then there may be splashes causing intermittently detected changes in process conditions. The sensor output delay ensures that the fork is dry or wet for a suitable period before switching.

Media density

The media density parameter is used to specify the specific gravity of the process medium.

Table B-2: Media Density Settings

Setting	Range
0.4 – 0.6 SG	400 to 600 kg/m ³
0.5 – 0.9 SG	500 to 900 kg/m ³
0.8 – 1.3 SG	800 to 1300 kg/m ³
1.2 – 3.0 SG ⁽¹⁾	1200 to 3000 kg/m ³

(1) Only available when the Sensor Operating Mode is set to Normal.

Additional options are available when the Sensor Operating Mode is set to Normal:

- Low compacted sediment
- Medium compacted sediment
- High compacted sediment
- Extreme compacted sediment

Calculated switching points for a process media

The measured frequency of the fork, when immersed in process medium, can be affected by liquid density variations. As a result, the dry-to-wet and wet-to-dry switching points are different for all types and varieties of process medium (Figure B-1).

To overcome this, accurate switching points are calculated by the level detector after a suitable density band is selected for the process medium.

Figure B-1: Example of Calculated Switching Points for a Process Media

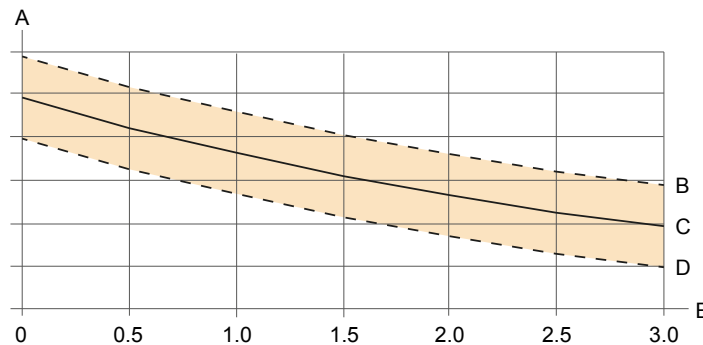

- A. Dry fork frequency
 B. Top limit boundary (allowing for variations in fork manufacture)
 C. Nominal switching point frequencies for this process medium
 D. Bottom limit boundary (allowing for variations in fork manufacture)
 E. Liquid density (SG)

Media learn

Media Learn makes configuring the Media Density variable even easier.

This procedure requires the fork tines to be fully immersed in the process medium for a short period to gather the frequency data, calculate the liquid density, and then auto-select the option for the Media Density variable.

Figure B-2: Fully Immersed Tines for Media Learn

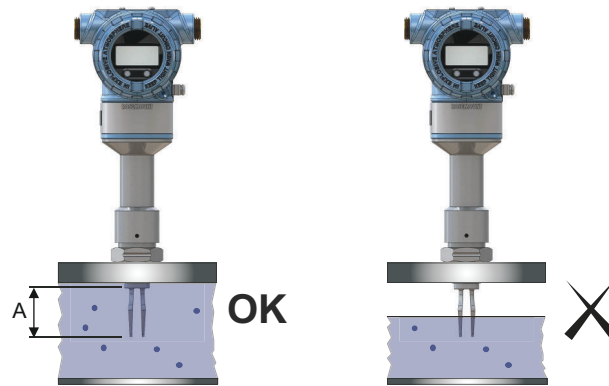

A. Tines fully immersed in process medium

Note

The Media Learn function may have unexpected results in processes with high temperatures.

Proof test

Duration of the proof test routine

The Proof-Test Duration parameter determines the duration of the whole partial proof-testing sequence.

Four steps performed are:

- Low Alarm Current step
 - The analog output current is overridden to the Low Alarm level (as configured).
- Off Current step
 - The analog output current is overridden to the level of the 'off' switched output state (as configured).
- On Current step
 - The analog output current is overridden to the level of the 'on' switched output state (as configured).
- High Alarm Current step
 - The analog output current is overridden to the High Alarm level (as configured).

Note

Setting a value of "0 s" (zero seconds) results in the analog output not being exercised during the proof-test. Only a diagnostic check of the device is performed in this case.

Start-up proof test

Enable or disable partial proof-testing at every power-up.

Allowable change in dry fork frequency

When the level detector is re-calibrated in the field, a comparison is made between the new dry fork frequency and original factory-set Dry Fork Frequency value. If the difference

is greater than the allowable change value, the re-calibration is rejected. Check the fork for damage, corrosion, or coating, and clean the fork if necessary before re-trying.

The default setting is 100 Hz, but can be set to a value in the range 0 to 255 Hz. Setting the value to 0 Hz switches off the allowable change monitoring.

Sensor fault delay

When the level detector is operating in Enhanced Mode and detects a fork sensor fault, Sensor State indicates a fault state after a delay.

The default setting is 5 seconds. It can be set to a value in the range 0 to 3600 seconds.

Note

When the Rosemount 2140 is operating in Normal mode, a fork sensor fault is not detected and Sensor State continues to indicate a valid state.

B.1.2 Analog output

The output current from the Analog Output connection is driven by the Primary Variable (“PV”). By default, the Output State is mapped to the PV.

By default, the Analog Output is configured to switch output currents between two levels (‘on’ or ‘off’). It can be re-configured to output a 4–20 mA signal over a specified range.

Sensor Frequency or Scaled Variable can instead be re-mapped to the PV.

Switched output currents

By default, the Output State device variable is mapped to the PV. In this case, the output current switches between two levels: 4 mA representing the ‘off’ (0.0) state and 20 mA representing ‘on’ (1.0) state.

4–20 mA signal

Depending on how the PV is mapped, e.g. to Sensor Frequency or Scaled Variable device variables, the Analog Output can be re-configured to output the PV as a 4–20 mA signal over a specified range.

Alarm signal

Depending on the alarm switch setting on the electronics board, alarm conditions can be signaled by switching the output current to the high alarm or low alarm current levels.

Current output type

This section is applicable when the PV is mapped to the Output State device variable.

Table B-3: Current Output types

Option	Description
4 and 20 mA (default)	4 mA = 'off' and 20 mA = 'on' switched output states.
8 and 16 mA	8 mA = 'off' and 16 mA = 'on' switched output states
Custom	The output current levels for 'off' and 'on' output states are user-entered under the Custom Off Current and Custom On Current variables. A minimum separation of 1 mA is enforced by the level detector.
LevelTester	This is a compatibility mode.

LevelTester output current

See [Table B-4](#) for output current information.

Table B-4: LevelTester Output Current

Output current	Wet on	Dry on
Wet	18.5±0.5 mA @ 0.5 Hz	6 mA
Dry	9 mA	13.5±0.5 mA @ 0.5 Hz

Current output operating mode

Options to select are:

- Dry on
- Wet on

The Sensor State variable uses these settings of "Dry on" and "Wet on" to associate with when the Output State variable is indicating 'on' (1.0).

Analog output range points

The PV LRV (Lower Range Value) variable is the primary variable represented by 4 mA, and the PV URV (Upper Range Value) variable is the primary variable represented by 20 mA. This primary variable range can be a sub-set of the sensor limits defined by Upper PV Limit and Lower PV Limit variables.

Sensor limits and validation of range points

[Table B-5](#) shows the sensor limits applied when different device variables are mapped to the PV dynamic variable. The limits are used for scaling gauges in a Host system and for validating the Analog Output range points.

Table B-5: Sensor Limits for Device Variables

Device Variable	PV Lower Limit	PV Upper Limit
Output State	0.0	1.0
Sensor State	0.0	1.0
Sensor Frequency	250.0 Hz	1800.0 Hz

Table B-5: Sensor Limits for Device Variables (continued)

Device Variable	PV Lower Limit	PV Upper Limit
Electronics Temperature	-40 °C	85 °C
Terminal Voltage	10.5 V	42.4 V
Scaled Variable	Defined by sensor frequency limits and scaling data.	

By default, the Output State is mapped to the PV. The range points for this are read-only and identical to the associated sensor limits.

Sensor Frequency or Scaled Variable can instead be re-mapped to the PV. The Analog Output range points then automatically change from read-only to editable, but are subject to the sensor limits.

Damping

Note

The section is applicable only when the PV is re-mapped to Scaled Variable device variable.

Damping is an optional parameter. Increasing the damping value can smooth wide variations in the output caused by rapid input changes, but at the cost of decreasing response times.

Settings range from 0.0 to 60.0 seconds. An appropriate setting is a balance of the necessary response time, signal stability, and other requirements of the loop dynamics within your system.

Alarm and saturation levels

Note

This section is not applicable when the level detector is in multi-drop mode.

The level detector continuously performs self-diagnostic routines. When there is a device malfunction that is classed as an alarm condition, the Analog Output current is driven to a fixed alarm level based on the HI or LO alarm switch position and the ordered Alarm Level code (see [Table B-6](#) to [Table B-8](#)).

In normal operation, the Analog Output current is driven in response to Primary Variable (“PV”) changes. When the PV is re-mapped to e.g. the Sensor Frequency device variable, values could potentially go outside sensor limits. As the output current would then be beyond the saturation points, the current is limited to a fixed saturation level based on the alarm switch position and the ordered Alarm Level code (see [Table B-6](#) to [Table B-8](#)).

Table B-6: Rosemount Alarm and Saturation Values (Alarm Level Code C8)

Level	4–20 mA saturation	4–20 mA alarm
Low (LO alarm switch position)	3.9 mA	≤ 3.75 mA
High (HI alarm switch position)	20.8 mA	≥ 21.75 mA

Table B-7: NAMUR-compliant Alarm and Saturation Values (Alarm Level Codes C4/C5)

Level	4–20 mA saturation	4–20 mA alarm
Low (LO alarm switch position)	3.8 mA	≤ 3.6 mA
High (HI alarm switch position)	20.5 mA	≥ 22.5 mA

Table B-8: Custom Alarm and Saturation Values (Alarm Level Code C1)

Level	4–20 mA saturation	4–20 mA alarm
Low (LO alarm switch position)	3.7 mA to 3.9 mA	3.6 mA to 3.8 mA
High (HI alarm switch position)	20.1 mA to 22.9 mA	20.2 mA to 23.0 mA

Failure mode alarm and saturation levels can be custom-configured. The following limitations exist for custom-configurable levels:

- Low alarm level must be less than the low saturation level.
- High alarm level must be higher than the high saturation level.
- Alarm and saturation levels must be separated by at least 0.1 mA.

The configuration tool will provide an error message if the configuration rules are violated.

Note

When set to HART multi-drop mode, all saturation and alarm information is sent digitally; saturation and alarm conditions will not affect the analog output.

B.1.3 Scaled variable

The Scaled Variable function is used to convert the Sensor Frequency variable data into other units. It also allows a user-entered description of the new custom units to be on the LCD display.

When the analog output is re-configured as a 4–20 mA signal output, the new custom units drive the Analog Output.

Scaled variable units

Enter the custom unit description to be displayed.

Scaled variable transfer function

Select the transfer function for the application: Linear or discrete.

Frequency input 1

The first frequency value which will be associated with the first scaled variable value.

Scaled output 1

The first scaled variable value which will be associated with the first frequency value.

Frequency input 2

The second frequency value which will be associated with the second scaled variable value.

Scaled output 2

The second scaled variable value which will be associated with second first frequency value.

Linear offset

The user entered offset which is added or subtracted from the calculated scaled variable output.

B.1.4 Device temperature

The units for the temperature measurements are selectable.

B.1.5 Display

Select variables to show on the optional LCD display. If more than one variable is selected, then the LCD display toggles between the output variables.

The LCD display can also be configured to show configuration information during the device startup. Select **Review Parameters at Startup** to enable this functionality.

B.1.6 HART protocol**Variable mapping**

Up to four device variables can be assigned for the HART protocol. The Primary Variable (PV) represents the 4–20 mA analog output signal. The other three variables (SV, TV, and QV) are digital.

Table B-9: Variable Mapping

Variable	PV		SV, TV, QV
	2140	2140:SIS	
Output State	Yes	Yes	Yes
Sensor State	No	No	Yes
Sensor Frequency	Yes	No	Yes
Scaled Variable	Yes	No	Yes
Electronics Temperature	No	No	Yes
Terminal Voltage	No	No	Yes

Default mapping

PV – Output State

SV – Sensor State

TV – Sensor Frequency

QV – Electronics Temperature

HART polling address

The polling address range is 0 to 63.

When the polling address is 0 (default), the level detector operates in the standard point-to-point mode with full Analog Output functions. For all other addresses, the level detector operates in multi-drop mode with the current output fixed to 4 mA and the Analog Output functions are not available.

HART dynamic variables are accessible digitally using the HART commands in any mode.

Related information

[Multidrop communication](#)

Burst mode

When set to burst mode, the level detector regularly sends out messages instead of waiting for the host to request it. HART5 devices supports one Burst message. HART7 devices support three Burst messages.

Almost all HART host systems today are designed to communicate in poll/response mode, not burst mode. If required, both level detector and host must be configured to operate in burst mode.

Related information

[HART burst mode](#)

B.1.7 Security

Security switch

By default, the security switch on the electronics board is in the unlock position (🔓) to allow configuration of the level detector. After completing the configuring tasks, the security switch should be set to the lock position (🔒).

HART lock

By default, this security is not enabled. The HART lock prevents changes to the configuration data from all sources.

Configuration buttons lock

By default, this security is not enabled. The configuration button lock disables all local button functionality.

LOI password

By default, this security is not enabled. A Local Operator Interface password can be set to disable the review and modification of configuration data.

Related information

[Security](#)

B.1.8 Frequency profiling

There are two frequency profiling functions supported:

- Minimum deviation
- Maximum deviation

Both functions monitor the fork sensor frequency changes.

Figure B-3: Frequency Profile Definition

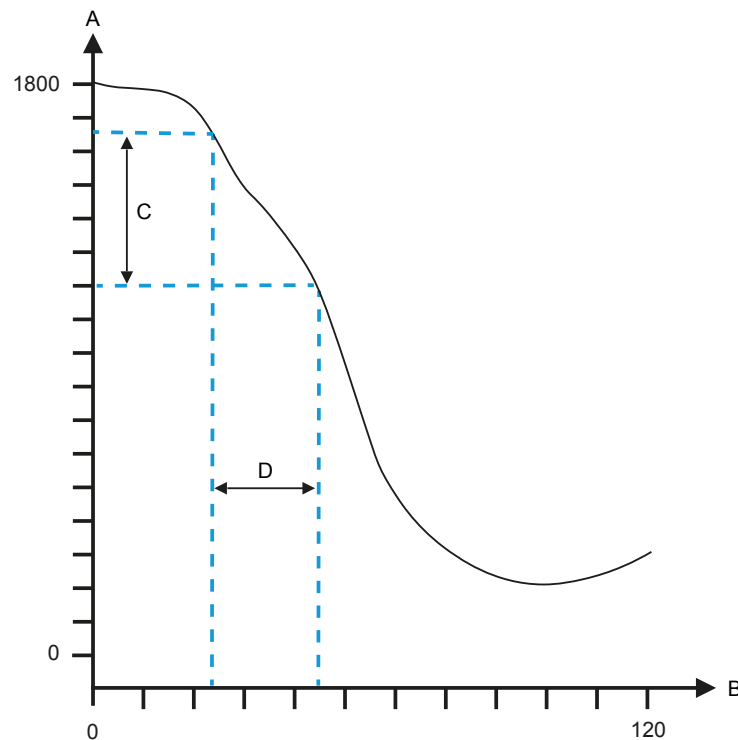

- Fork frequency (Hz)
- Time (seconds)
- Minimum and maximum frequency deviation, Δf
- Minimum and maximum deviation duration, Δt

Minimum deviation frequency

The smallest change in sensor frequency that must occur during the minimum deviation duration in order to prevent an alert from being generated.

Minimum deviation duration

The period of time in which the Sensor Frequency must change by more than the minimum deviation in order to prevent an alert from being generated.

Maximum deviation frequency

The change in sensor frequency occurring during the maximum deviation duration that will cause an alert to be generated.

Maximum Deviation Duration

The period of time during which a change in the sensor frequency greater than the maximum deviation will cause an alert to be generated.

Applications for minimum deviation function

The minimum frequency deviation is designed for use in applications such as:

- The circuit is working properly with a faulty fork sensor, in which the circuit might generate a very stable frequency output within the tolerances of a minimum deviation in the minimum deviation duration.
- The circuit might be locked in a self-resonant frequency unexpectedly where the frequency output might be very stable as well.

Applications for the maximum deviation function

The maximum frequency deviation is designed for use in applications such as:

- The fork sensor or its wires might be half-broken, or in an intermittent working condition, where the vibration frequency might be jumping up and down.
- An alert is to be generated if the process level has been raised or fallen too rapidly, perhaps due to large ripples on the surface or leakage in a vessel (tank).

B.1.9 Device information

Tag

Identifier of up to 8 characters for the device used by host system. The tag is typically a reference number, location, or duty description.

Long tag

Identifier of up to 32 characters for the device used by host system. It is recommended to enter both a short and a long tag (they may be the same).

Date

The date field can be used for any purpose, for example to save the date of the last configuration change.

Descriptor

The 16-character descriptor field can be used for any purpose.

Message

The 32-character message field can be used for any purpose, such as providing details of the last configuration change.

B.2 Alert setup

B.2.1 Process alerts

Process alerts allow the level detector to indicate when a pre-set data point is exceeded. Alerts can be set for the following device variables:

- Output State
- Sensor State
- Sensor Frequency
- Scaled Variable (if supported)
- Electronics Temperature
- Terminal Voltage

An active alert is displayed on the status screen of a host or on the LCD display. When the value returns within range, an alert is reset.

Alert mode

Select “on” to enable the alert, or “off” to switch the alert off.

High alert value

Defines the upper boundary limit for a device variable value.

Note

The high alert value must be higher than the low alert value. Both alert values must also be within the fork sensor limits.

Low alert value

Defines the lower boundary limit for a device variable value.

Related information

[Sensor limits and validation of range points](#)

B.2.2 Power advisory

The optional Power Advisory diagnostic provides a means to detect issues that may jeopardize the integrity of the electrical loop. Some examples are: water entering the wiring compartment and making contact with the terminals, an unstable power supply nearing end of life, or heavy corrosion on the terminals.

This technology is based on the premise that, after the level detector is installed and powered up, the electrical loop has a baseline characteristic that reflects the proper installation. If the terminal voltage of a level detector deviates from the baseline and is outside a pre-set threshold, the level detector can generate a HART alert or analog alarm.

To make use of this diagnostic, first create a baseline characteristic for the electrical loop after a level detector has been installed. The electrical loop is automatically characterized

with the push of a button. This creates a linear relationship for expected terminal voltage values along the operating region from 4–20 mA (see Figure B-4).

Figure B-4: Baseline Operating Region

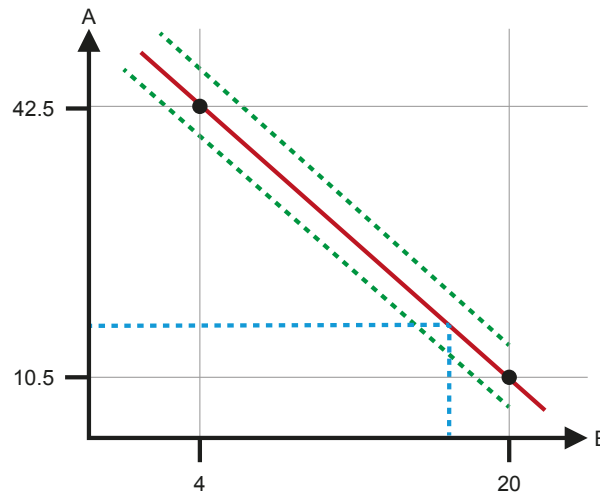

- A. Terminal voltage (Vdc)
- B. Output current (mA)

The level detector is shipped with the Power Advisory function switched off and without any loop characterization performed. After the level detector is installed and powered-up, the loop characterization must be performed for Power Advisory to function.

When initiating a loop characterization, the level detector first checks to see if the loop has sufficient power for proper operation. Next, the output is driven to 4 and 20 mA points to establish a baseline and determine the maximum allowable terminal voltage deviation. After this is complete, enter a sensitivity threshold called Terminal Voltage Deviation Limit. A check is made to make sure this threshold value is valid.

With the loop characterized and Terminal Voltage Deviation Limit is set, the Power Advisory function actively monitors the electrical loop for deviations from the baseline. Now, the level detector generates an alert or alarm whenever the terminal voltage changes (relative to the expected baseline value) and exceeds the Terminal Voltage Deviation Limit.

Note

Power Advisory monitors and detects changes in the terminal voltage from expected values to detect common failures. It is not possible to predict and detect all types of electrical failures on the 4-20 mA analog output. Therefore, Emerson cannot absolutely warrant or guarantee that Power Advisory will accurately detect failures under all circumstances.

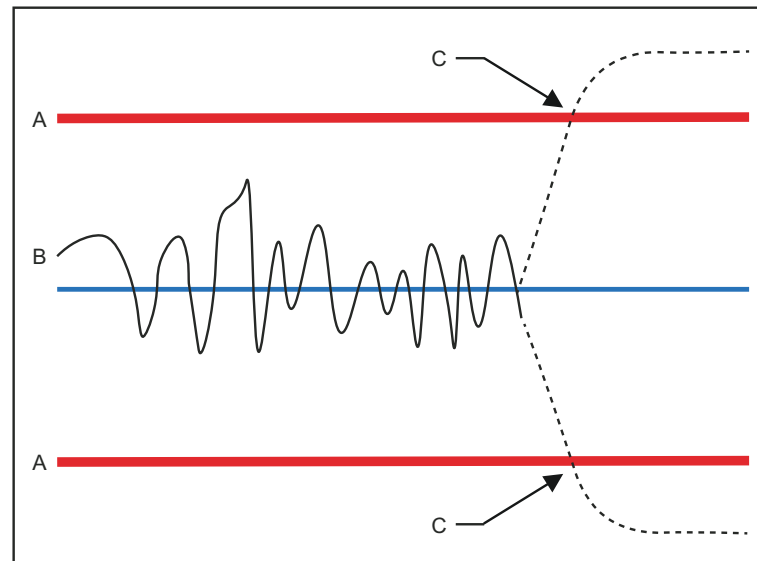
Figure B-5: Voltage Deviation Limit

- A. Voltage deviation limit
- B. Terminal voltage
- C. Alert

NOTICE

Severe changes in the electrical loop may inhibit HART communication or the ability to reach alarm values. Therefore, Emerson cannot absolutely warrant or guarantee that the correct failure alarm level (high or low) can be read by the host system at the time of annunciation.

Terminal voltage

This field shows the current terminal voltage value in volts. The terminal voltage is a dynamic value and is directly related to the mA output value.

Terminal voltage deviation limit +/-

The Terminal Voltage Deviation Limit should be set large enough such that expected voltage changes do not cause false failures.

Resistance

This value is the calculated resistance of the electrical loop (in W) measured during the loop characterization procedure. Changes in the resistance may occur due to changes in the physical condition of the loop installation. Baseline and previous baselines can be compared to see how much resistance has changed over time.

Power supply

This value is the calculated power supply voltage of the electrical loop (in volts) measured during the loop characterization procedure. Changes in this value may occur due to

degraded performance of the power supply. Baseline and previous baselines can be compared to see how much the power supply has changed over time

Characterize loop

Loop characterization must be initiated when the level detector is first installed or when electrical loop characteristics have been intentionally altered. Examples include a modified power supply level or loop resistance of the system, changing the terminal block on the level detector, or adding a Smart Wireless THUM to the level detector.

Note

Power Advisory is not recommended for a level detector operating in multi-drop mode.

Power Advisory action

When the voltage deviation exceeds the set limit, four possible actions can be configured and can be set to “Latched” or “Unlatched”.

When the alert or alarm is unlatched, the alert or alarm will disappear if voltage deviation returns to a normal level. A latched alarm or alert will not disappear when the voltage deviation returns to normal levels. This requires the user to acknowledge and clear the alert or alarm.

The four Power Advisory diagnostic actions are:

- None
- Alert latched
- Alarm unlatched
- Alert unlatched

C Local Operator Interface (LOI) menu trees

C.1 LOI menu trees

Figure C-1: LOI Menu Trees (Part 1)

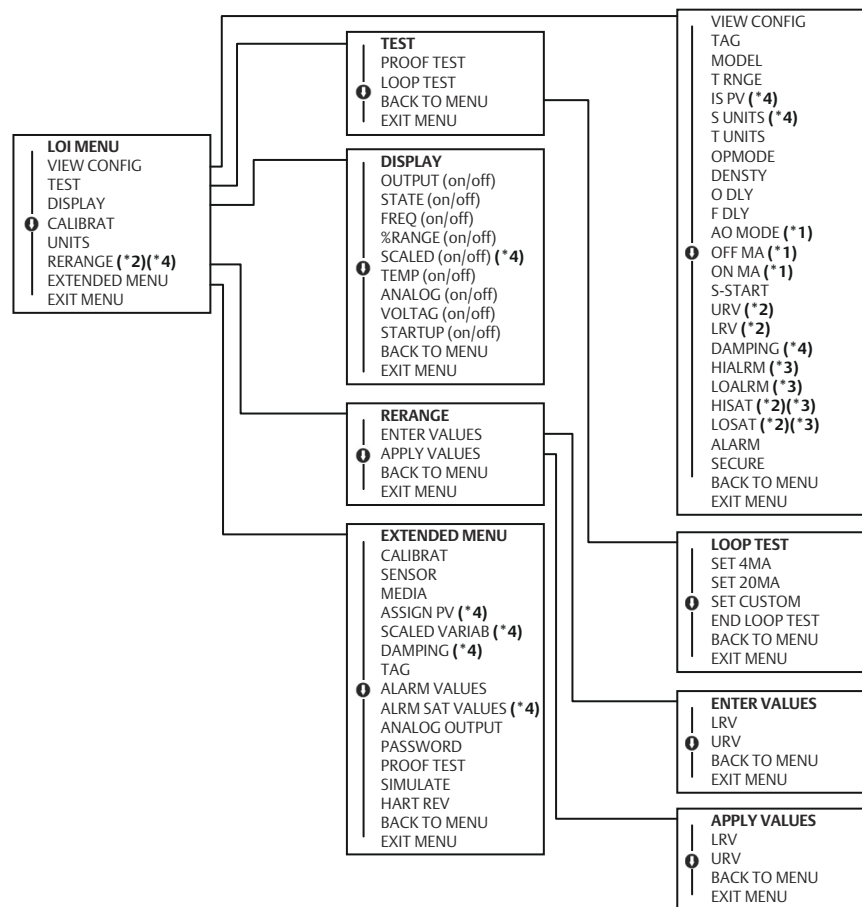

(*1) Only visible when the Primary Variable (“PV”) is mapped to the Output State variable.

(*2) Only visible when the Primary Variable (“PV”) is mapped to the Sensor Frequency or Scaled Variable variables.

(*3) Alarm level and saturation level depend on the Alarm Level switch setting and the ordered Alarm Level option code.

(*4) Not available for Rosemount 2140: SIS.

Figure C-2: LOI Menu Trees (Part 2)

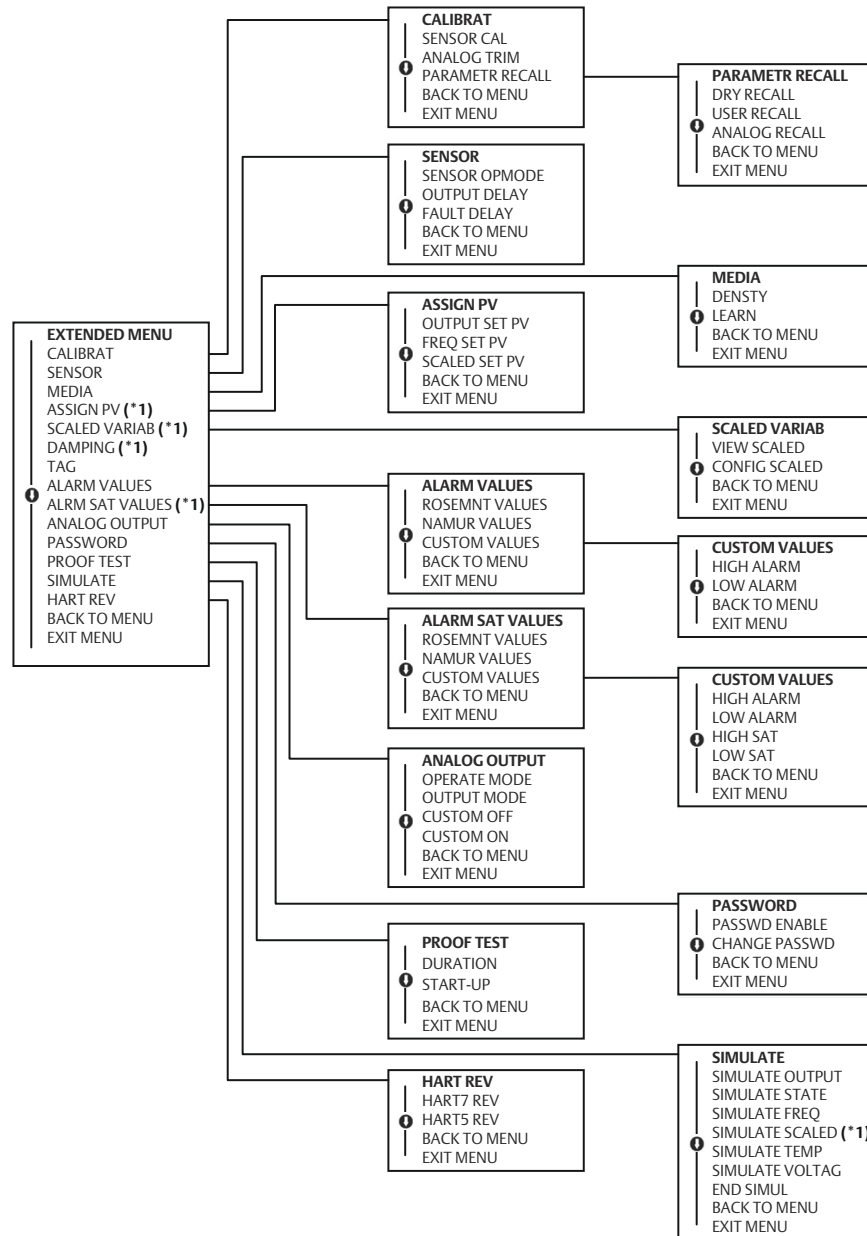

(*1) Not available for Rosemount 2140: SIS.

D Signal processing

Figure D-1 is a schematic overview of the signal processing.

Figure D-1: Flowchart of Signal Processing

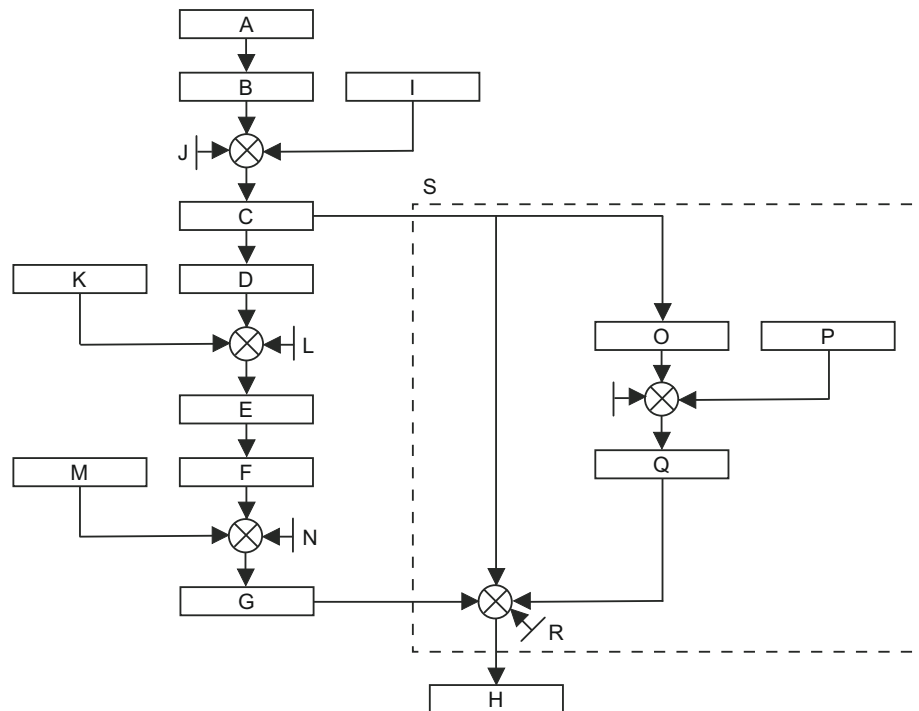

- A. Sensor
- B. Frequency measurement
- C. Sensor frequency
- D. Sensor state determination and validation
- E. Sensor state
- F. Output state determination
- G. Output state
- H. Current output
- I. Frequency simulation
- J. Sensor frequency simulation enabled
- K. Sensor state simulation
- L. Sensor state simulation enabled
- M. Output state simulation
- N. Output state simulation enabled
- O. Scaled variable calculation
- P. Scaled variable simulation
- Q. Scaled variable
- R. PV selection
- S. Rosemount 2140 version only

For more information: [Emerson.com](https://www.emerson.com)

©2022 Emerson. All rights reserved.

Emerson Terms and Conditions of Sale are available upon request. The Emerson logo is a trademark and service mark of Emerson Electric Co. Rosemount is a mark of one of the Emerson family of companies. All other marks are the property of their respective owners.

ROSEMOUNT™

