

Rosemount™ TankMaster™ Floating Roof Monitoring

for tank gauging systems



NOTICE

Read this manual before working with the product. For personal and system safety, and for optimum product performance, ensure you thoroughly understand the contents before installing, using, or maintaining this product. For equipment service or support needs, contact your local Emerson representative.

The products described in this document are NOT designed for nuclear-qualified applications. Using non-nuclear qualified products in applications that require nuclear-qualified hardware or products may cause inaccurate readings. For information on Rosemount nuclear-qualified products, contact your local Emerson Sales Representative.

Spare Parts

Any substitution of non-recognized spare parts may jeopardize safety. Repair, e.g. substitution of components etc, may also jeopardize safety and is under no circumstances allowed.

Rosemount Tank Radar AB will not take any responsibility for faults, accidents, etc caused by non-recognized spare parts or any repair which is not made by Rosemount Tank Radar AB.

⚠ WARNING

Failure to follow safe installation and servicing guidelines could result in death or serious injury.

Ensure only qualified personnel perform the installation.

Use the equipment only as specified in this manual. Failure to do so may impair the protection provided by the equipment.

Do not perform any services other than those contained in this manual unless you are qualified.

To prevent ignition of flammable or combustible atmospheres, disconnect power before servicing.

Substitution of components may impair Intrinsic Safety.

⚠ WARNING

Explosions could result in death or serious injury.

Verify that the operating atmosphere of the transmitter is consistent with the appropriate hazardous locations certifications.

Before connecting a communication device in an explosive atmosphere, be sure that the instruments in the loop are installed in accordance with intrinsically safe or non-incendive field wiring practices.

Do not remove the gauge cover in explosive atmospheres when the circuit is alive.

⚠ WARNING

Electrical shock could cause death or serious injury.

Use extreme caution when making contact with the leads and terminals.

⚠ WARNING

Physical access

Unauthorized personnel may potentially cause significant damage to and/or misconfiguration of end users' equipment. This could be intentional or unintentional and needs to be protected against.

Physical security is an important part of any security program and fundamental in protecting your system. Restrict physical access by unauthorized personnel to protect end users' assets. This is true for all systems used within the facility.

Contents

Chapter 1	Overview.....	5
	1.1 Introduction.....	5
	1.2 System overview.....	5
	1.3 Installation procedure.....	10
Chapter 2	Installation.....	11
	2.1 Installation considerations.....	11
	2.2 Mechanical installation.....	12
Chapter 3	Configuration.....	23
	3.1 Introduction.....	23
	3.2 Floating roof monitoring setup.....	24
Chapter 4	Operation.....	41
	4.1 Open tank view.....	41
	4.2 Configure alarm limits.....	43
	4.3 Alarm disconnect.....	45
	4.4 Roof monitoring group view.....	46
	4.5 Roof monitoring historical data.....	49
	4.6 Roof status.....	52
	4.7 Alarm priority.....	57
Chapter 5	Service and troubleshooting.....	59
	5.1 Troubleshooting.....	59
Appendix A	Commissioning Checklist.....	61

1 Overview

1.1 Introduction

The floating roof monitoring function in Rosemount TankMaster™ detects whether a roof in a storage tank is stuck, sinking, floating higher or lower than normal, covered by water or product, or is tilted.

TankMaster uses three to six tilt gauges to track inclination of a floating tank roof. Roof floating high/low status may be monitored as well. The monitoring function is based on using Rosemount 3308 wireless level transmitters mounted on the tank roof, or shell mounted free propagation radar level gauges measuring distance to the tank roof.

If roof inclination exceeds a maximum alarm limit, TankMaster triggers an alarm. Also, if the tank roof floats higher or lower than normal, it may indicate that the roof is stuck or is about to sink. An alarm is triggered in TankMaster if the floating roof passes high or low alarm limits.

One or two extra transmitters can be used to detect if the roof drain gets plugged or if there is any hydrocarbons (product) present on the tank roof. The drain gauge can be either a Rosemount 3308 wireless transmitter providing an online level value of tank roof drain sump, or a wireless vibrating fork which will act as a high level alarm switch. Hydrocarbons may be detected by any hydrocarbon detection system which can provide a digital output signal to be connected with a Rosemount 702 Wireless Discrete Transmitter.

The roof monitoring function is enabled by an option in the Rosemount TankMaster hardware key. In TankMaster WinSetup a tank must be configured as a **Floating Roof Tank** to allow using the floating roof monitoring function.

Level radars are installed at multiple points, spaced evenly around the perimeter of the roof. The following installation options are available:

- Shell mounted with/without level reference
- Roof mounted

1.1.1 Drain sump monitoring and hydrocarbon detection

A drain gauge and/or a hydrocarbon gauge can be added to the floating roof monitoring system. The drain gauge is installed in the drain sump and detects if the drain clogs and water does not run off. Rosemount 3308 Wireless Guided Wave Radar or Rosemount 2160 Wireless Vibrating Fork can be used for drain sump monitoring.

Installed at the floating roof, the hydrocarbon gauge detects potential hydrocarbons on the roof. Typically, a Rosemount 702 Wireless Discrete Transmitter with Liquid Hydrocarbon Detection is used.

1.2 System overview

The floating roof monitoring function is based on using one of two tilt gauge installation options:

- shell mounted at the top of the tank
- on the tank roof

The shell mounted version is also suitable for fixed roof tanks with inner floating roof.

1.2.1 Shell mounted installation at top of tank

Three to six non-contacting level gauges are installed at the top of the tank. The gauges are mounted on brackets and measure distance to reflector plate on top of the tank roof.

Roof tilt is monitored by comparing distance to the tank roof measured by the different tilt level gauges.

Tank roof floating high/low calculations can be done by comparing distance to floating roof with distance to the product surface measured by a reference level gauge in a still-pipe.

Figure 1-1: Shell mounted tilt gauges installed at the top of the tank

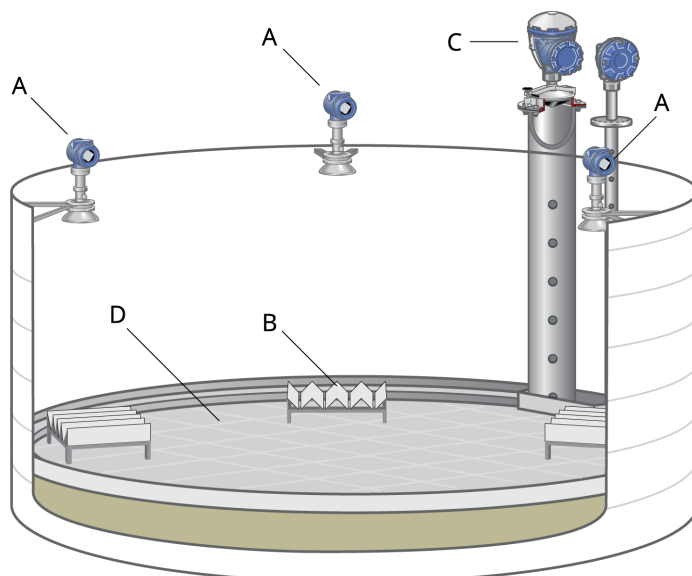

- A. Tilt gauge mounted on top of tank
- B. Reflector
- C. Reference gauge for product level measurements
- D. Floating roof

1.2.2 Installation on tank roof

Three to six tilt gauges are installed on the tank roof. Probes penetrate the tank roof measuring distance from roof to product surface.

By comparing the distance to the product surface measured by each tilt gauge, both roof tilt and buoyancy can be monitored.

Wireless Rosemount 3308 tilt gauges communicate with the host system via a repeater at the top of the tank.

Figure 1-2: Roof mounted wireless Rosemount 3308 transmitters

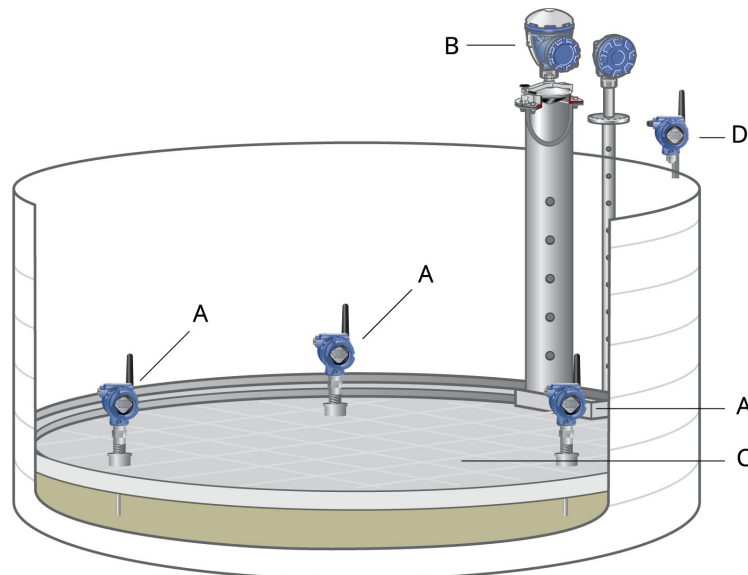

- A. Tilt gauge mounted on tank roof
- B. Radar gauge for product level measurements
- C. Floating roof
- D. Repeater

1.2.3 Floating roof installation characteristics

Figure 1-3: Shell mounted tilt gauges

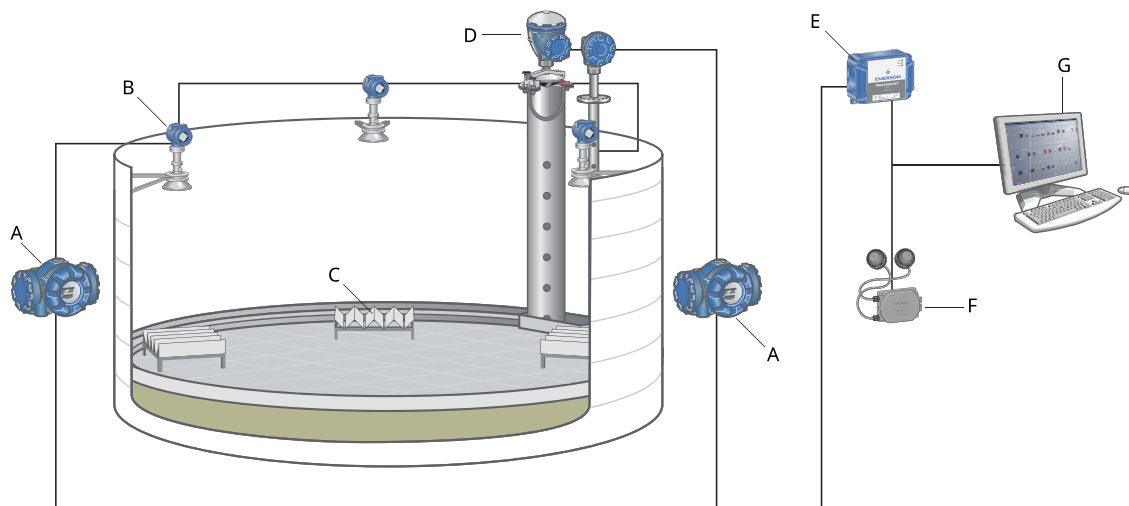

- A. Rosemount 2410 Tank Hub
- B. Tilt gauge
- C. Reflector
- D. Reference level gauge for product level measurements
- E. Rosemount 2460 System Hub
- F. Emerson Wireless Gateway
- G. Rosemount TankMaster host

Figure 1-4: Roof mounted tilt gauges

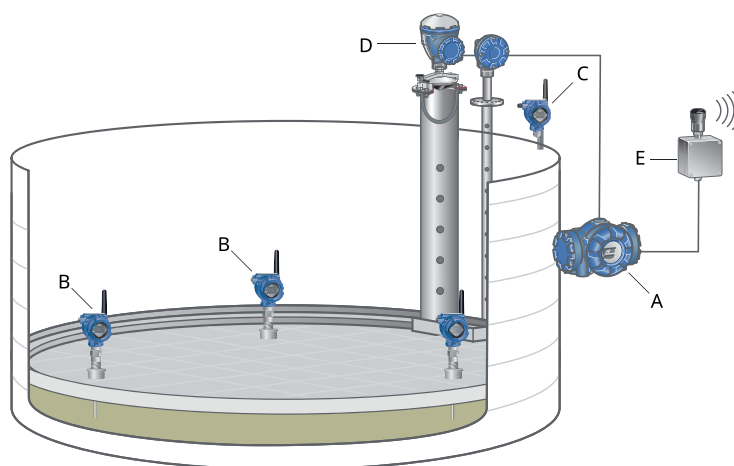

- A. Rosemount 2410 Tank Hub
- B. Tilt gauge
- C. Repeater
- D. Reference level gauge for product level measurements
- E. Emerson Wireless 775 THUM Adapter

Tank installation characteristics

Table 1-1: Floating roof tank installation characteristics

	Shell mounted with/without level reference	Roof mounted
Radar device	Rosemount 5408 or 5900C non contacting radars	Rosemount 3308 Wireless Guided Wave Radars
Number of radar devices	Minimum three, maximum six	Minimum three, maximum six
Installation	Installed at top of tank shell ⁽¹⁾ . Also suitable for fixed roof tanks with inner floating roof.	Directly on floating roof
Level	Measures distance to the floating roof	Measures distance to the liquid
Tilt	Tracks tilt by comparing measured distance from radars to the floating roof	Tracks tilt by comparing measured distance to the liquid
Roof floating	Tracks roof floating high/low by referencing liquid surface ⁽²⁾	Tracks roof floating high/low by measuring distance to the liquid
Possible alerts/alarms	<ul style="list-style-type: none"> • Roof tilt • Roof floating high/low⁽²⁾ • Drain sump full with water⁽³⁾ • Hydrocarbons detected⁽⁴⁾ 	<ul style="list-style-type: none"> • Roof tilt • Roof floating high/low • Drain sump full with water⁽³⁾ • Hydrocarbons detected⁽⁴⁾
Data transmission to control room	Wired connection from level gauge to tank hub. Wired or wireless communication from tank hub to control room.	Wireless communication

(1) Local site license may be required for compliance to frequency spectrum approval.

(2) Requires level reference (inventory level gauge in still-pipe).

(3) Requires drain sump gauge.

(4) Requires hydrocarbon detection gauge.

1.3 Installation procedure

Follow these steps for proper installation of the Rosemount TankMaster Roof Monitoring system:

Procedure

1. Make sure that a site plan is available with tank tags, device tags, and device addresses.
2. Review mounting considerations for the devices.
3. Install the devices.
4. Wire and power up the devices.
5. Configure the devices.
6. Setup the floating roof monitoring function.

Related information

[Installation considerations](#)

[Mechanical installation](#)

[Configuration](#)

2 Installation

2.1 Installation considerations

- Verify that the tank roof is designed to allow tilt gauge installation according to requirements.
- Ensure that roof mounted tilt gauges are installed properly to allow reliable measurements when the roof tilts or sinks.
- Ensure that shell mounted tilt gauges are installed at a sufficient distance from the highest roof position.

Note

Local site license may be required for compliance to frequency spectrum approval.

Related information

[Mechanical installation](#)

2.2 Mechanical installation

The Floating Roof Monitoring system is based on using a number of tilt gauges which measure the distance to the tank roof. There is also an option which is based on installing level gauges on the tank roof in order to monitor the distance between tank roof and product surface. Throughout this manual we will refer to these two versions:

- Shell mounted
- Roof mounted

Related information

[Installation considerations](#)

2.2.1 Installation on tank shell

This option uses three to six tilt gauges mounted on brackets. It is recommended that tilt gauges are mounted on a bracket arm and not a wide plate.

In case there is a level gauge for product level measurements as well, it can be used as a reference for tank roof floating high/low calculations.

Figure 2-1: Floating roof with tilt gauges on top of tank

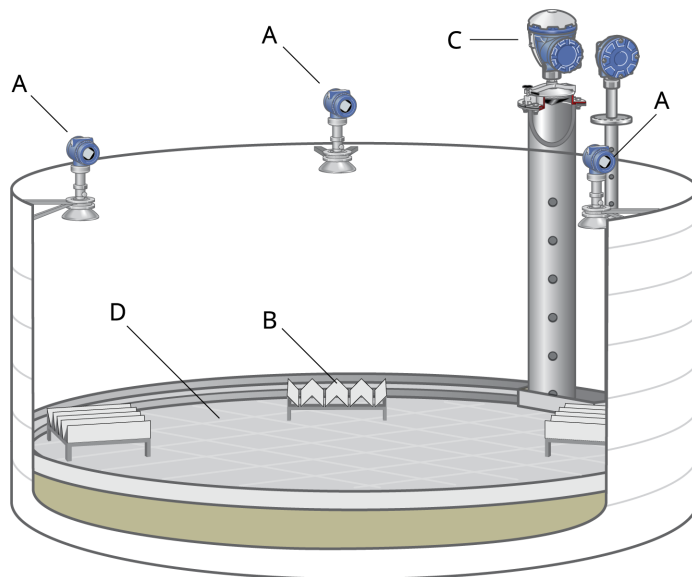

- A. Tilt gauge mounted on top of tank
- B. Reflector
- C. Reference gauge for product level measurements
- D. Floating roof

It is important that each tilt gauge is installed at a position where the roof and reflector can not come into contact with the antenna.

Ensure that the bracket is long enough to fulfill minimum recommendations for distance from wall to tilt gauge.

The tilt gauge should be installed at zero degrees vertical inclination.

Figure 2-2: Installation recommendations

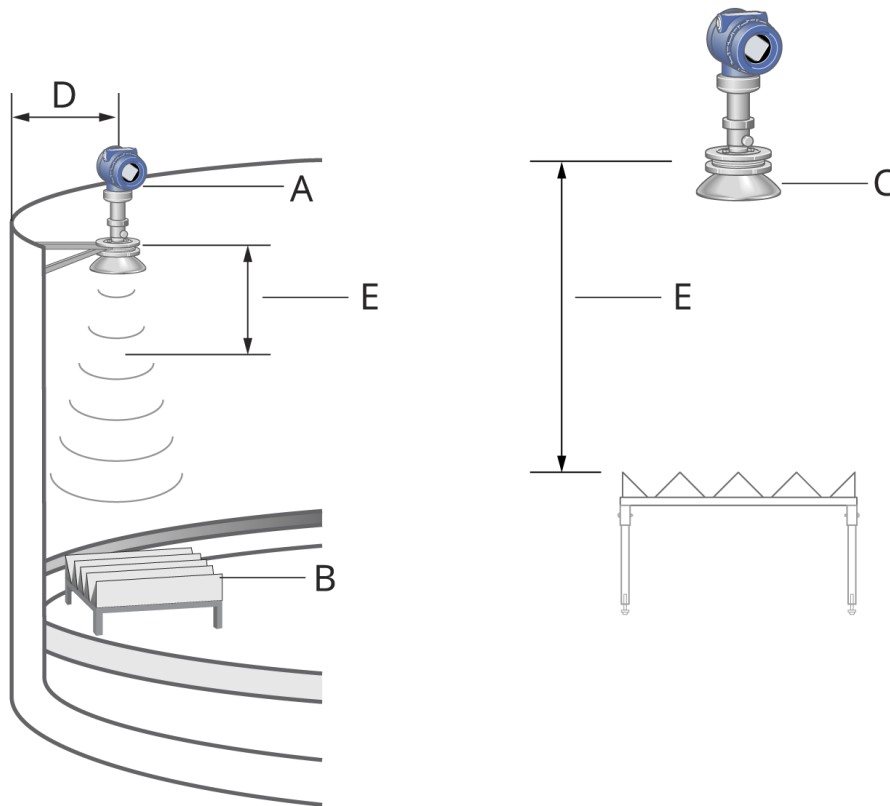

- A. Tilt gauge
- B. Reflector
- C. Antenna
- D. Minimum distance 800 mm (31.5 in.)
- E. Recommended free space 800 mm (31.5 in.). Minimum distance 500 mm (19.7 in.)

Related information

- [Inclination](#)
- [Reflector design](#)
- [Antenna orientation](#)

Reflector design

Shell mounted tilt gauges measure the distance to a reflector(1) placed on the tank roof. Ensure that the reflector meets recommended design specifications in order to prevent contamination build-up. The gap (B) between ridges will ensure that water and snow can drip off the reflector.

Note

Note It is recommended to regularly make visual inspections to verify that each reflector is placed in the right position.

Figure 2-3: Reflector for measuring distance to tank roof

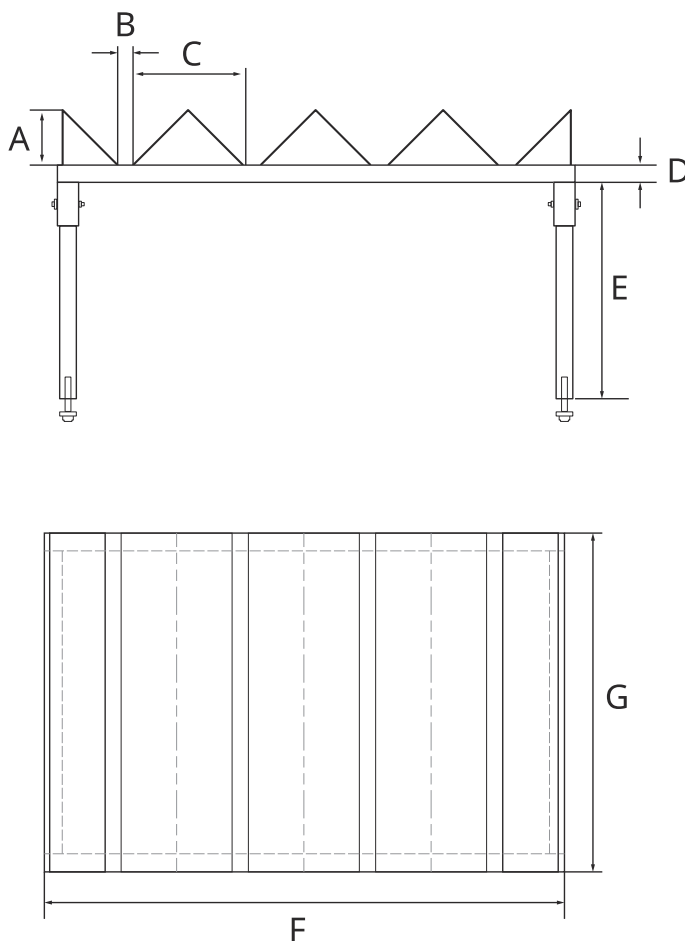

- A. 130 mm (5.12 in.)
- B. 35 mm (1.4 in.)
- C. 260 mm (10.2 in.)
- D. 40 mm (1.6 in.)
- E. 500 mm (19.7 in.)
- F. 1200 mm (47.2 in.)
- G. 780 mm (30.7 in.)

Antenna orientation

Figure 2-4: Antenna orientation with rosemount 5900c transmitter head as reference

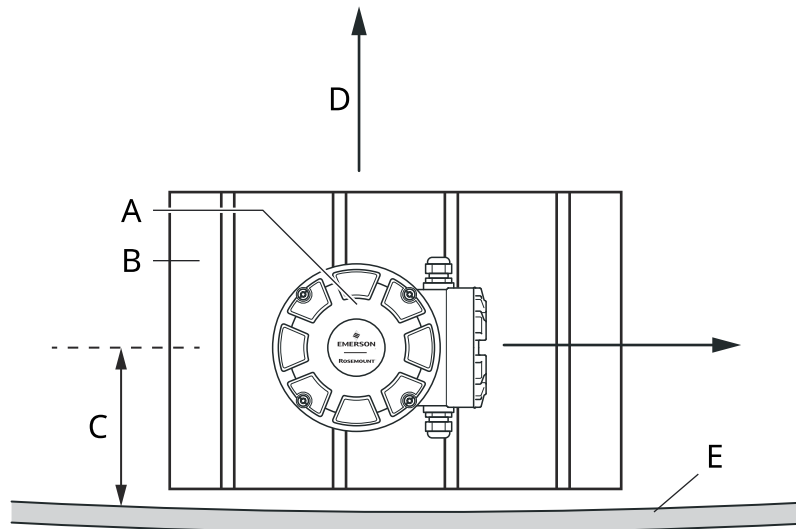

- A. Tilt gauge
- B. Reflector
- C. Minimum 31.5 in. (800 mm)
- D. Center of tank
- E. Tank wall

Figure 2-5: Antenna orientation for Rosemount 5408

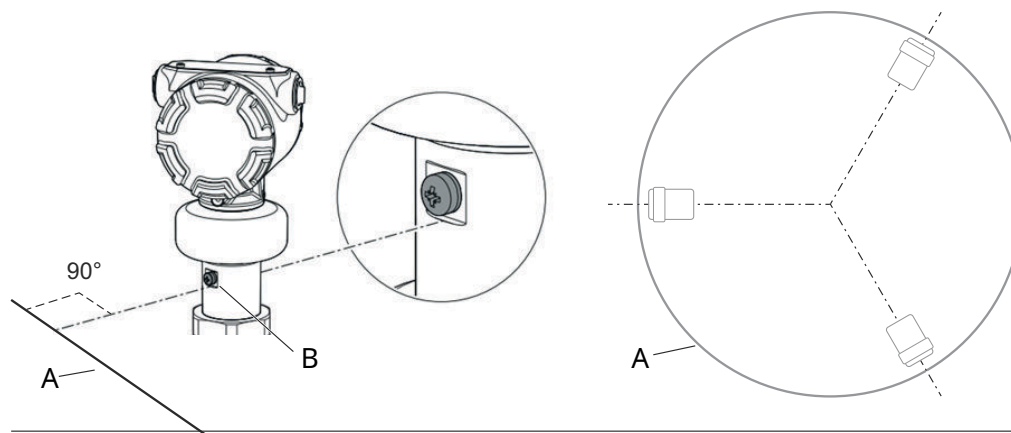

- A. Tank wall
- B. External ground screw

Related information

[Reflector design](#)

Inclination

Make sure that the tilt gauge is vertically aligned with the reflector. This will ensure that maximum signal strength is reflected back to the gauge.

Figure 2-6: Antenna inclination

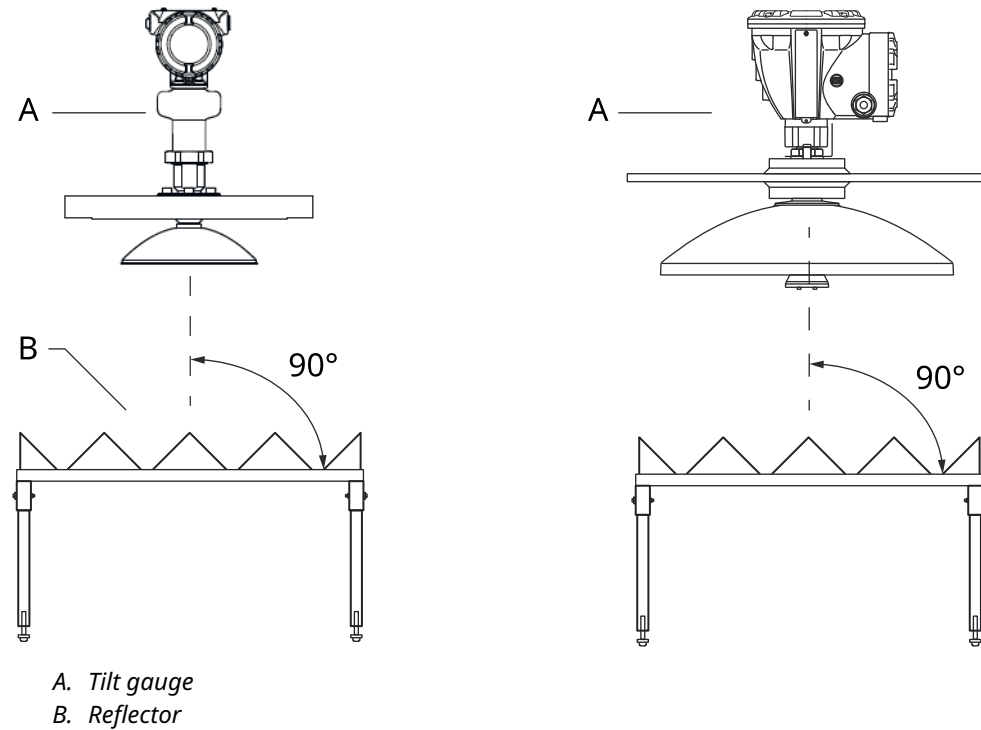

Related information

[Reflector design](#)

2.2.2 Installation on tank roof

Three to six tilt gauges can be installed on the tank roof allowing tilt and roof floating high/low measurements. A repeater at the top of the tank ensures proper communication between the wireless tilt gauges and the gateway.

Note

Make sure that battery power is regularly verified by, for example, using the gateway web interface. Wireless network communication should be verified according to IEC 62591 (WirelessHART®) standards best practice.

Figure 2-7: Tilt gauges on tank roof

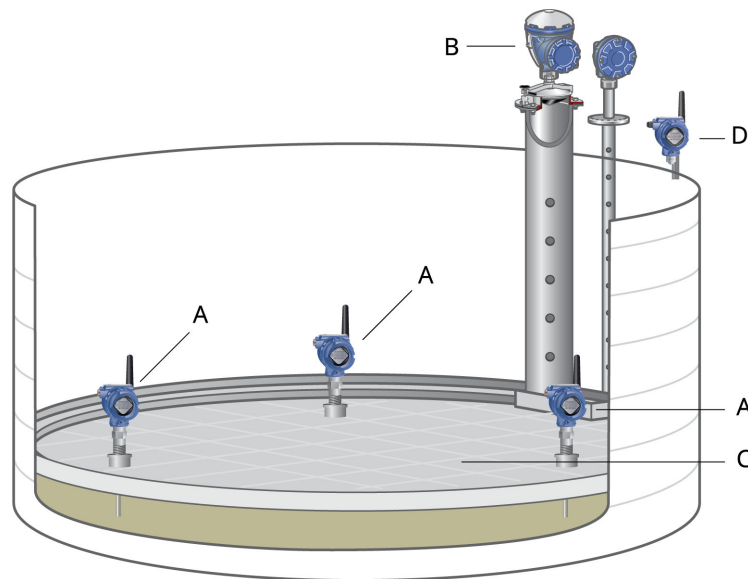

- A. Tilt gauge mounted on tank roof; Rosemount 3308 Wireless Guided Wave Radar transmitter
- B. Reference level gauge for product level measurements
- C. Floating roof
- D. Repeater

Free space

Make sure that there is free space underneath the probe when the roof has landed at the bottom of the tank.

It is recommended that the nozzle is ventilated for pressure equalization. This will ensure that pressure build-up is released in case the roof sinks. A flushing ring connection can be used in case the nozzle is not ventilated.

Figure 2-8: Rosemount 3308 installation on tank roof

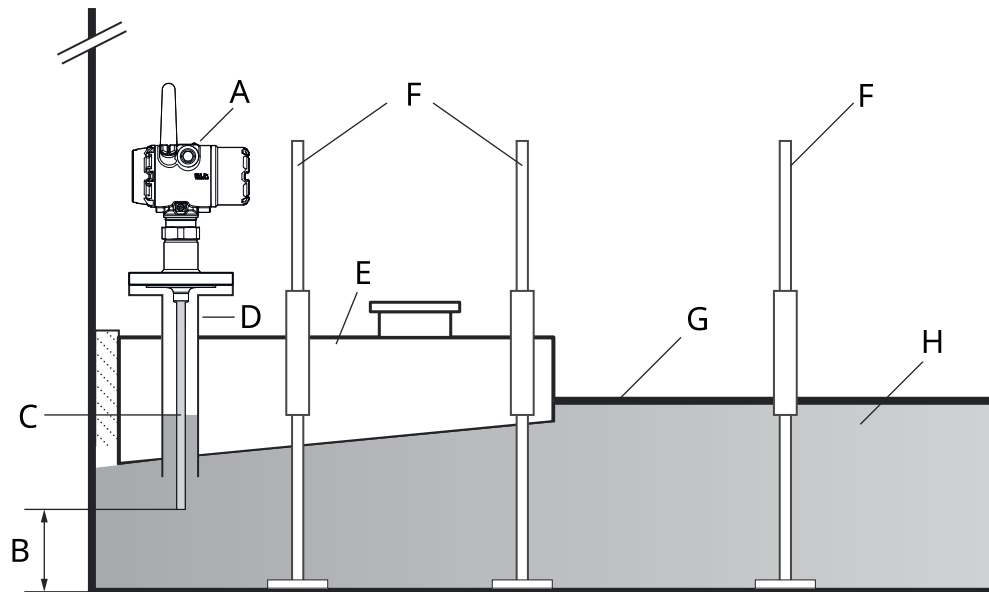

- A. Rosemount 3308 tilt gauge
- B. Free space
- C. Probe
- D. Nozzle
- E. Pontoon
- F. Roof support
- G. Floating roof
- H. Liquid

Geometry

It is important that the nozzle is high enough to ensure that the product surface does not reach the level transmitter's Blind Zone in case the roof tilts or sinks. Make sure that there is sufficient measuring range margin as illustrated in [Figure 2-9](#).

Normal Distance is a configuration parameter that designates the distance between the upper reference point and the product surface when the tank roof floats freely and is horizontal with no tilt. A deviation from Normal Distance indicates that the roof is stuck or sinking.

Prior to putting the Floating Roof Monitoring system in operation, it is recommended to hand dip each tilt gauge nozzle in order to find the exact **Normal Distance**. This value will be needed in the **Floating Roof Monitoring** setup. The hand dip value allows you to verify that the tilt gauge is measuring on the actual product surface.

Note

Make sure all roof monitoring alarm limits are configured inside the measuring range.

Figure 2-9: Blind Zone and measuring range

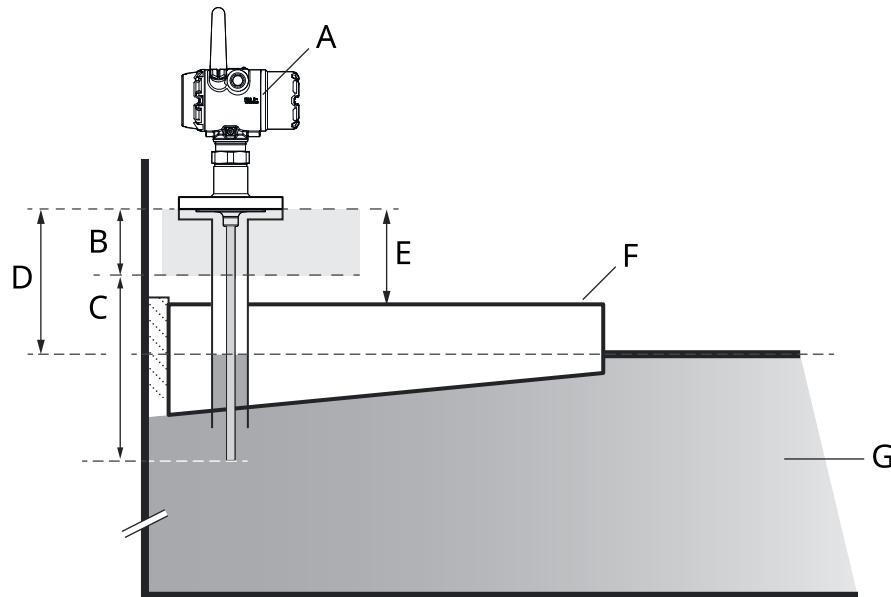

- A. Rosemount 3308 tilt gauge.
 - B. Blind Zone.
 - C. Measuring range.
 - D. Normal distance. This parameter is configured in the **Floating Roof Monitoring Setup** window.
 - E. Minimum nozzle height=200 mm.
 - F. Floating roof.
 - G. Liquid.
-

Related information

[Roof mounted](#)

[Rosemount 3308 Reference Manual](#)

2.2.3 Tilt gauge position

It is recommended that the tilt gauges are installed in such a way that they are spread out evenly around the tank roof as illustrated below. You may use a minimum of three tilt gauges. Up to six tilt gauges may be used if required.

Figure 2-10: Position on tank roof

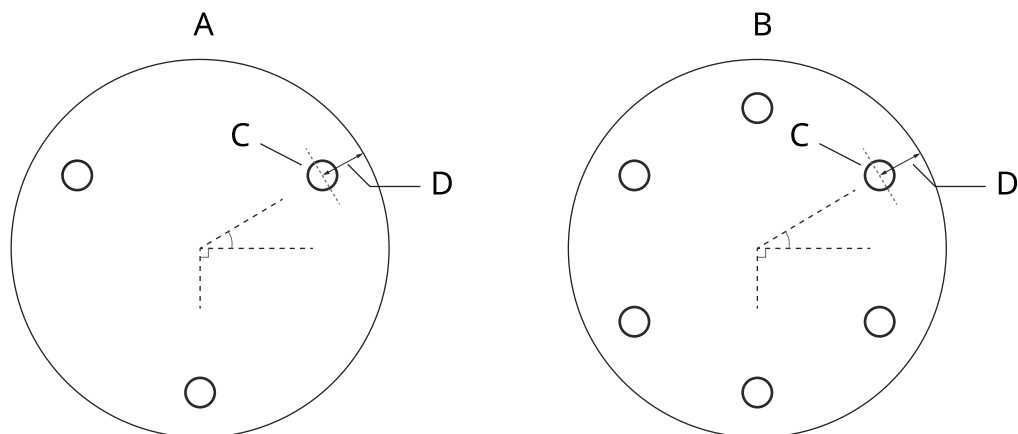

- A. Minimum 3 tilt gauges
- B. Maximum 6 tilt gauges
- C. Tilt gauge
- D. Distance to tank wall

2.2.4 Drain sump monitoring

A Rosemount 3308 Wireless Guided Wave Radar or a Rosemount 2160 Wireless Vibrating Fork can be used for drain sump monitoring.

Figure 2-11: Drain sump gauges

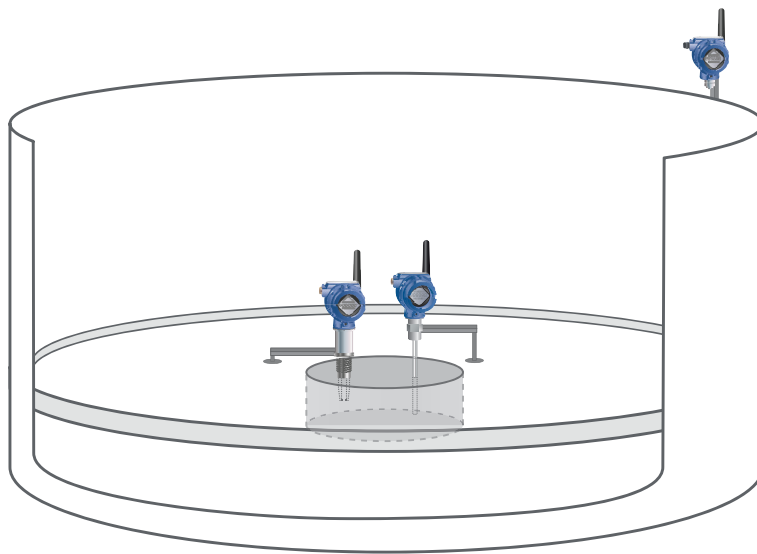

2.2.5 Hydrocarbon detection

A Rosemount 702 Wireless Discrete Transmitter with Liquid Hydrocarbon Detection can be used for detecting hydrocarbons on the roof.

Figure 2-12: Hydrocarbon gauge

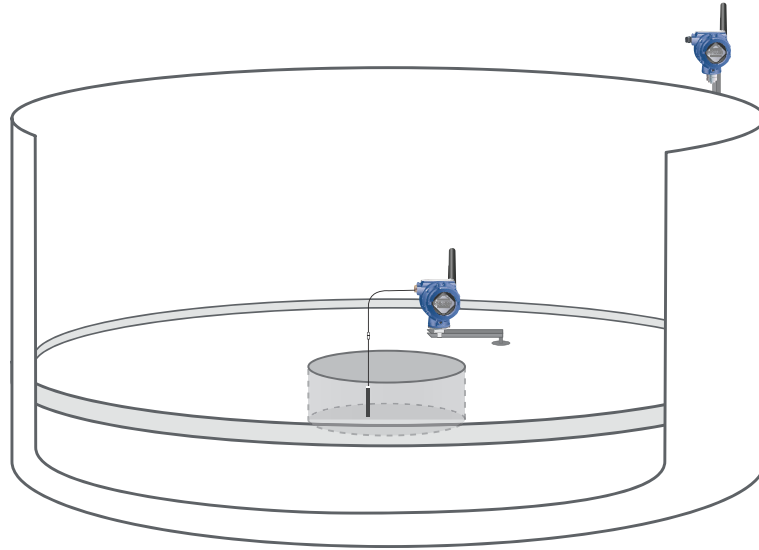

3 Configuration

3.1 Introduction

It is important that configuration is properly prepared by providing the appropriate information that is needed for setting up a Rosemount Tank Gauging system. For example, you will need tank geometry parameters, antenna type for level gauges, Unit Id and Modbus communication addresses.

The purpose of tank configuration is to associate level gauges and other devices to specific tanks. In a Floating Roof Monitoring system you will need to configure reference gauge for level measurements as well as tilt gauges for floating roof monitoring. Drain and Hydrocarbon gauges may also be used and therefore need to be installed prior to setting up the floating roof monitoring system. Tank configuration is part of the standard installation procedure for a Rosemount Tank Gauging system.

Note

Prior to setting up a Rosemount TankMaster Floating Roof Monitoring system, all devices need to be installed, wired, and configured according to the standard procedure.

3.1.1 Inventory calculations

Note that for tilt gauge mounting type Shell mounted with Level Reference and Roof mounted you will need to make sure that inventory calculations are setup. This is required for calculating floating roof status such as **Landed**, **Partially Landed**, and **Roof Floating High/Low**.

Related information

[Rosemount TankMaster WinOpi Reference Manual](#)

3.2 Floating roof monitoring setup

Prior to setting up the Floating Roof Monitoring function, make sure that reference level gauge and tilt gauges are configured according to the standard procedure for Rosemount radar level gauges. Also, in case drain gauge and/or hydrocarbon gauge will be used, you will have to install these devices too and ensure that proper communication is established with the host computer system.

It is important that the roof floats horizontally in its normal position when setting up the roof monitoring function. The roof must float freely and may not be stuck at the tank wall.

3.2.1 TankMaster WinSetup workspace

The WinSetup workspace shows installed tanks and devices. A Floating Roof tank with tilt gauges for roof monitoring will appear as shown in Figure 3-1. Tilt gauges, as well as associated devices such as level gauges and temperature transmitters, will be shown.

Figure 3-1: Associated devices and tilt gauges appear in the WinSetup workspace

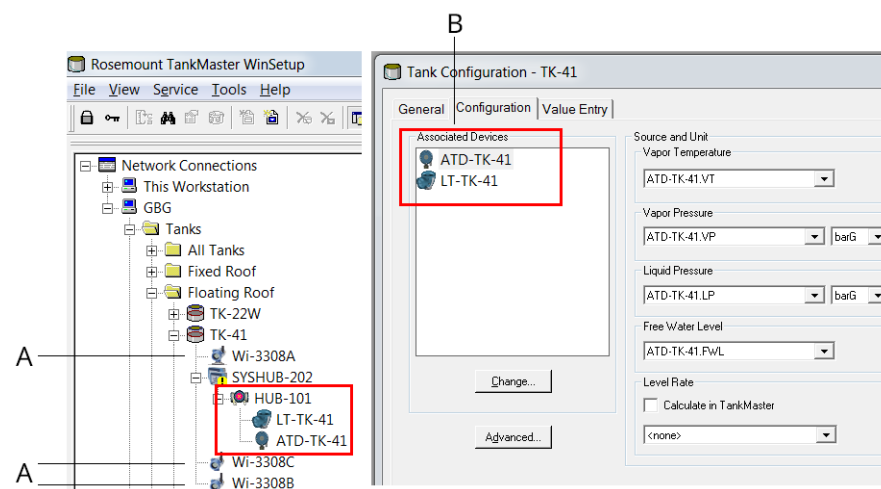

A. Tilt gauges

B. Level gauge and temperature transmitter associated with the tank

3.2.2 To enable floating roof monitoring

The Floating Roof Monitoring function requires hardware key option **Roof Monitoring Setup**.

Procedure

1. Open the **Rosemount TankMaster WinSetup** program.
2. In the **WinSetup** workspace, select the desired tank icon.
3. Click the right mouse button on the tank icon and select **Floating Roof Monitoring**.

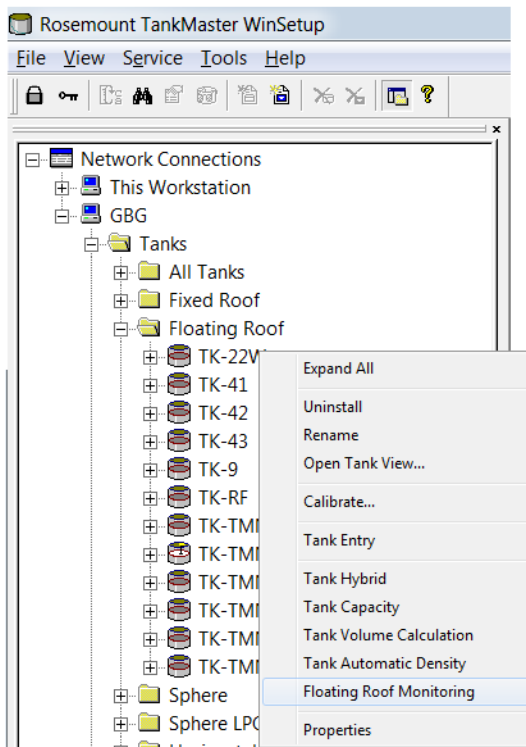

- In the **Floating Roof Monitoring Setup** window, select the **Enable...** check box in the upper left-hand corner.

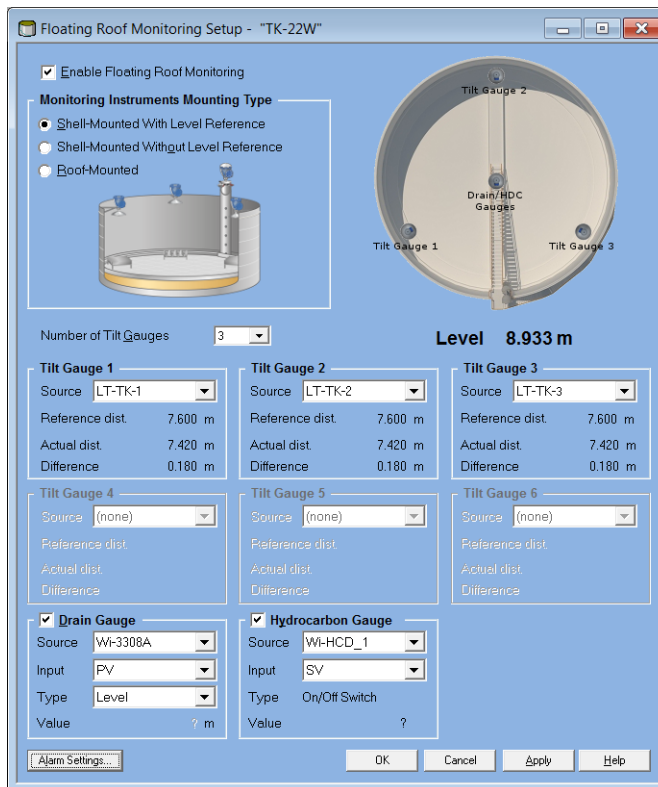

- Select the mounting type that corresponds to your installation. Available options are:
 - shell mounted with reference gauge
 - shell mounted without reference gauge
 - roof mounted
- Configure tilt gauges, drain gauge, and hydrocarbon gauge if available.

The **Floating Roof Monitoring Setup** window lets you enable and configure the monitoring system.

Table 3-1: Floating Roof Monitoring Setup

Mounting type	<ul style="list-style-type: none"> • Shell, with reference level gauge • Shell, without reference level gauge • Roof mounted
Tilt gauge	Number of tilt gauges, tilt gauge source device.
Drain gauge	Source, input, type.
Hydrocarbon gauge	Source, input.
Alarm settings	Roof tilt, Roof floating, Drain sump.

3.2.3 Shell mounted with level reference

This option includes tilt gauges and a level reference gauge. Prior to setting up the Floating Roof Monitoring system, the reference gauge needs to be installed and configured according to the standard procedure for Rosemount radar level gauges.

In case reference gauge tank geometry needs to be adjusted at a later stage, make sure that the floating roof monitoring setup is updated as well.

For the tilt gauges, you should use the same **Tank Reference Height (R)** as the Reference Level gauge. Start by using the following parameter settings for the tilt gauges prior to setting up the floating roof monitoring function.

Table 3-2: Initial tank geometry parameters for tilt gauges

Parameter	Initial value
Tank Reference Height (R)	Same as for the Level Reference Gauge.
Reference Distance (G)	0. This value will be changed later when setting up the floating roof monitoring function.
Minimum Level Distance (C)	0
Calibration Distance	0

Note

These parameters may be changed at a later stage.

Figure 3-2 shows geometry settings configuration for the Rosemount 5900C. Basically the same geometry settings are used for a Rosemount 5408 transmitter.

Figure 3-2: Example of Tank Geometry Settings for Rosemount 5900C

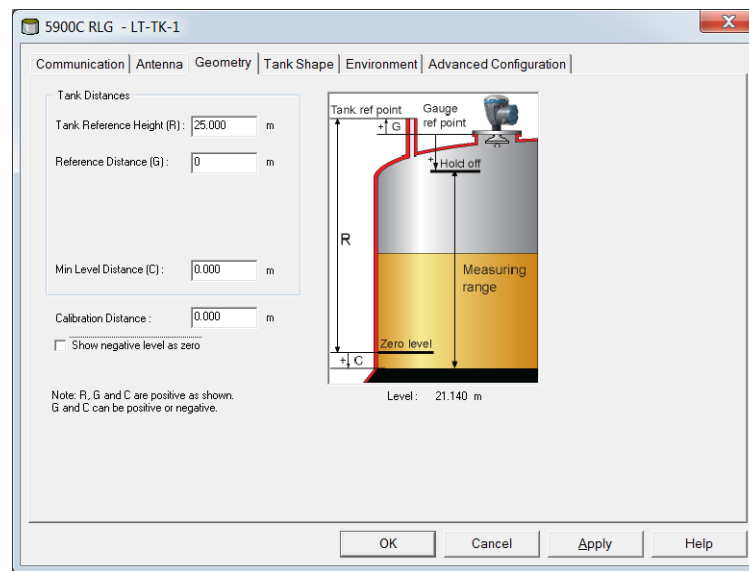

Floating roof monitoring setup

Ensure that Floating Roof Monitoring is enabled. Select the **Shell-Mounted with Level Reference** option.

Figure 3-3: Mounting type

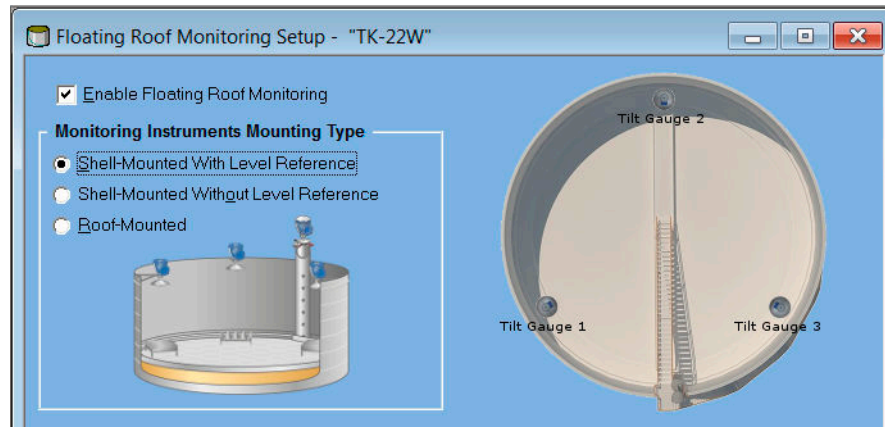

You may use three to six tilt gauges. Prior to setting up the Floating Roof Monitoring function, make sure that the tilt gauges are properly installed and configured. Check that all tilt gauges are available and appear in the **Source** drop-down list.

Since the tilt gauges may be installed at slightly different heights on the tank shell, in most cases the measured distance to the reflector on the tank roof will differ. Make sure that each tilt gauge is calibrated to show **Difference** equal to zero (Reference Distance - Actual Distance = 0).

Figure 3-4: Tilt gauge configuration for shell mounted with level reference gauge

Number of Tilt Gauges		Level	
3		8.933 m	
Tilt Gauge 1			
Source	LT-TK-1		
Reference dist.	7.600 m		
Actual dist.	7.420 m		
Difference	0.180 m		
Tilt Gauge 2			
Source	LT-TK-2		
Reference dist.	7.600 m		
Actual dist.	7.420 m		
Difference	0.180 m		
Tilt Gauge 3			
Source	LT-TK-3		
Reference dist.	7.600 m		
Actual dist.	7.420 m		
Difference	0.180 m		
Tilt Gauge 4			
Source	(none)		
Reference dist.			
Actual dist.			
Difference			
Tilt Gauge 5			
Source	(none)		
Reference dist.			
Actual dist.			
Difference			
Tilt Gauge 6			
Source	(none)		
Reference dist.			
Actual dist.			
Difference			

Related information

[Calibration](#)

Number of tilt gauges

Ensure that number of tilt gauges corresponds to the actual number of tilt gauges installed on the tank roof. You may use up to six tilt gauges.

Source

For each tilt gauge, select the desired gauge from the **Source** drop-down list.

Verify that the selected tilt gauge corresponds to the actual gauge on the tank roof.

Calibration

Each tilt gauge needs to be calibrated prior to using the Floating Roof Monitoring function. This means that **Difference** is set equal to zero (Reference Distance - Actual Distance = 0).

The **Reference Level** gauge measures distance to the product surface. Each shell-mounted tilt gauge measures the distance to a reflector placed on the tank roof. Tilt gauges and reference level gauge may be installed at different heights, in most cases the **Actual Distance** measured by a **tilt gauge** will differ from the **Reference Distance** measured by the **reference gauge**. Roof floating and tilt calculations are based on monitoring the difference between Actual Distance and Reference Distance. As long as the roof floats horizontally in its normal position, the difference between Actual Distance and Reference Distance will remain constant. If the roof gets stuck, sinks, or tilts, the difference will change.

Note

Prior to calibrating, ensure that the roof is floating in its normal stable position in the product liquid. Ensure that it is not stuck on the tank wall. No filling or emptying may occur during the calibration procedure.

Ensure that all gauges that will be used as tilt gauges are installed and available in the Source drop-down list. For each tilt gauge, select the desired source device.

Reference distance is the distance from the Gauge Reference Point of the Reference Level Gauge to the product surface.

Actual distance is the distance from the Tilt Gauge Reference Point to the reflector.

Difference is equal to the difference between **Reference** distance and **Actual** distance.

Related information

[Tilt gauge calibration procedure](#)

Tilt gauge calibration procedure

Configure the tilt gauges so that Difference = 0 when the floating roof is horizontal and floats at its normal position.

Procedure

1. In the **Floating Roof setup** window, check the **Difference** parameter. This value is equal to Reference Distance - Actual Distance.
2. In the TankMaster Winsetup workspace, open the tilt gauge **Properties** window:
 - a) locate the tilt gauge,
 - b) click the right mouse button on the tilt gauge icon,
 - c) select **Properties**.
3. In the **Properties** window, select the **Geometry** tab.
4. In the **Reference Distance (G)** input field, enter the current value for the **Difference** parameter which appears in the **Floating Roof Monitoring Setup** window.
5. Click the **Apply** button.
6. Wait a couple of minutes to allow the level gauge to settle.
7. In the **Floating Roof Monitoring Setup** window, check that Difference=0. If it is not you may need to slightly adjust the Reference Distance (G) again.

Example

An example of how to perform a calibration is illustrated in [Table 3-3](#).

The **Reference Distance (G)** tank geometry parameter (see the **Properties/Geometry** window) is used as a calibration offset in order to ensure that the Actual Distance (**A**) to the reflector (**C**) measured by the tilt gauge equals the distance (**D**) to the product surface measured by the reference level gauge (see [Figure 3-5](#)). This will compensate for different mounting positions of tilt gauges and reference level gauge, and for different position of reflector and product surface.

Table 3-3: Example of Reference Distance (G) calibration for tilt gauge

Configuration Parameters	Description
	<p>Difference = 0.218 Difference = Reference Distance - Actual Distance</p>
	<p>Reference Distance (G) In TankMaster WinSetup, open the Properties/Geometry tab for the tilt gauge and enter 0.218 for Reference Distance (G). Click Apply.</p>
	<p>Difference = 0 After a short settling time, the Reference Distance and Actual Distance should be equal, i.e. Difference = 0.</p>

Figure 3-5: Tank geometry for tilt gauge and reference level gauge



A	Actual distance; distance from tilt gauge to reflector + tilt gauge Reference Distance (G)
B	Tilt gauge
C	Reflector
D	Reference distance; distance from reference level gauge to product surface
E	Reference level gauge
F	Reference point for the level reference gauge
G	Tilt gauge Reference Distance (G) ⁽¹⁾
R	Tank Reference Height (R) ⁽¹⁾

(1) See **Properties** → **Geometry** window for the tilt gauge in TankMaster WinSetup Configuration Software.

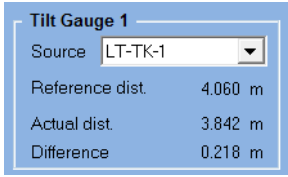
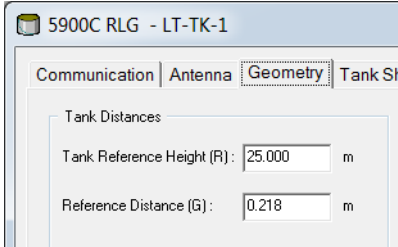
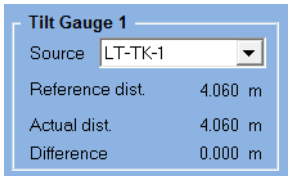
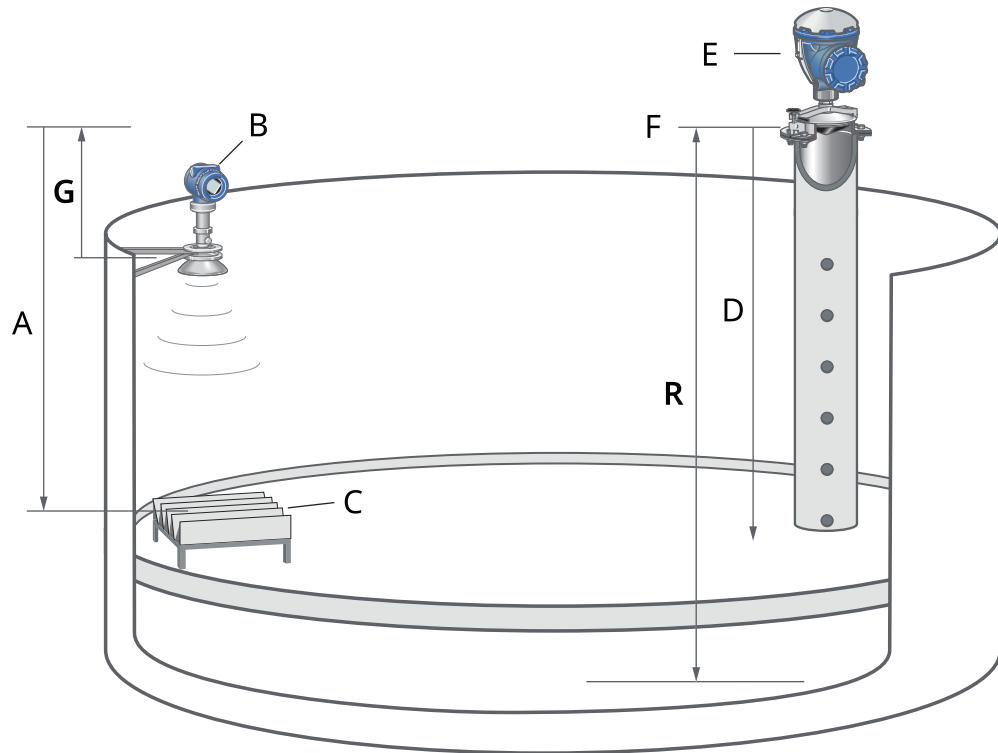
Alarm Setup

The **Alarm Setup** button in the **Floating Roof Monitoring Setup** window lets you configure alarm limits for roof tilt, roof floating high/low, and drain sump.

Related information

[Alarm setup](#)

3.2.4 Shell mounted without level reference

This option supports roof tilt monitoring only. Roof floating high/low can not be calculated since no reference level gauge is available.

Prior to setting up the Floating Roof Monitoring system, the tilt gauges have to be installed and configured according to the standard procedure for Rosemount radar level gauges.

Figure 3-6: Mounting Type

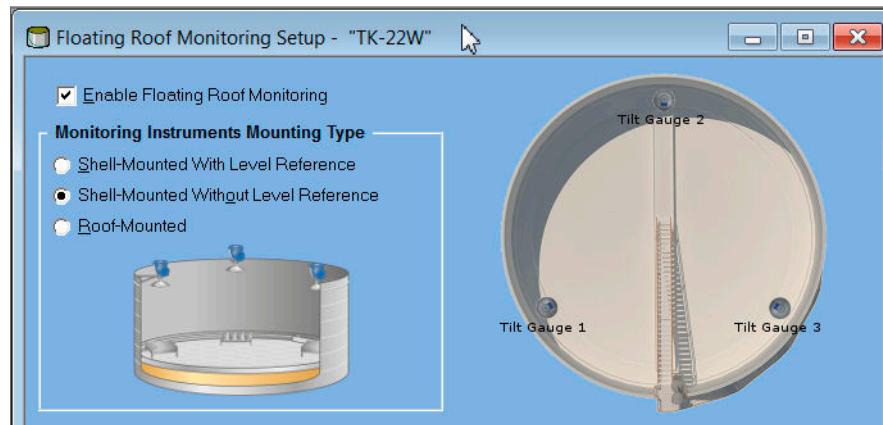

Tilt gauge configuration

You may use three to six tilt gauges. Prior to setting up the Floating Roof Monitoring function, make sure that the tilt gauges are properly installed and configured. Check that all tilt gauges are available and appear in the **Source** drop-down list.

Since the tilt gauges may be installed at slightly different heights on the tank shell, the measured distance to the reflector on the tank roof will differ.

Figure 3-7: Tilt Gauge Configuration for Shell Mounted without Level Reference

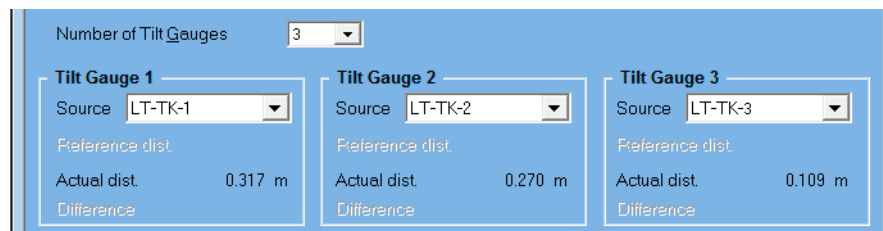

Number of tilt gauges

Ensure that number of tilt gauges corresponds to the actual number of tilt gauges installed on the tank roof. You may use up to six tilt gauges.

Source

For each tilt gauge, select a gauge from the **Source** drop-down list.

Calibration

Make sure that the tilt gauges are calibrated to show the same distance to the reflector in the **Floating Roof Monitoring Setup** window. This distance is presented as the **Actual distance**.

Procedure

1. In TankMaster WinSetup, open the **Floating Roof Monitoring Setup** window.
2. Check that all tilt gauges are up and running and present an **Actual Distance**.

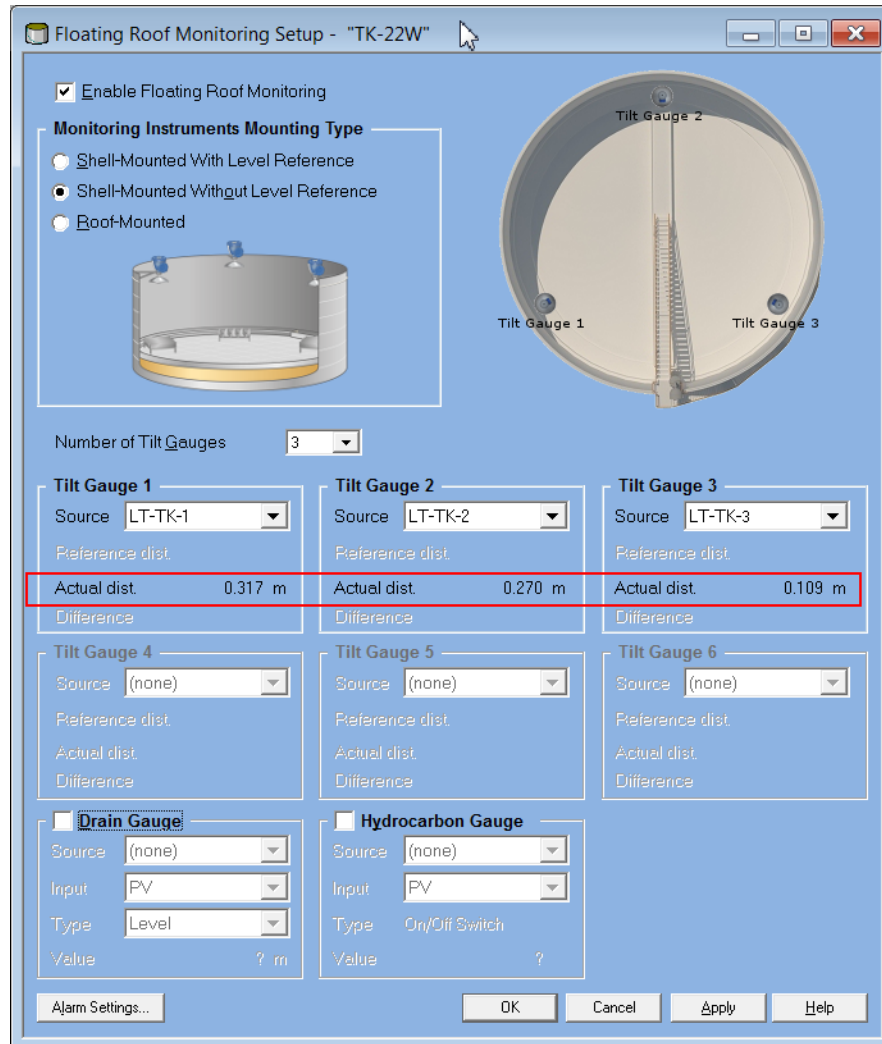

3. Note **Actual Distance** for one of the tilt gauges as a reference.
4. In the **TankMaster WinSetup** workspace, right-click the device icon for the next tilt gauge.
5. Click **Properties** and select the **Geometry** tab.
6. Adjust **Reference Distance (G)** so the tilt gauge presents the same **Actual Distance** as the first one.

7. Repeat this procedure until all tilt gauges are configured.

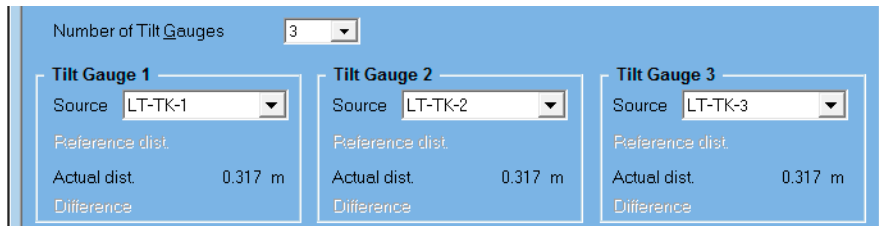

Alarm Setup

The **Alarm Setup** button in the **Floating Roof Monitoring Setup** window lets you configure alarm limits for roof tilt, roof floating high/low, and drain sump.

Related information

[Alarm setup](#)

3.2.5 Roof mounted

Rosemount 3308 transmitters are used as tilt gauges for mounting type Roof Mounted.

Prior to setting up the Floating Roof Monitoring system, the tilt gauges have to be installed and configured according to the standard procedure for Rosemount radar level gauges.

Note

Ensure that Primary Variable (PV)=Distance for all Rosemount 3308 tilt gauges.

Figure 3-8: Configuration of Roof Mounted Tilt Gauges

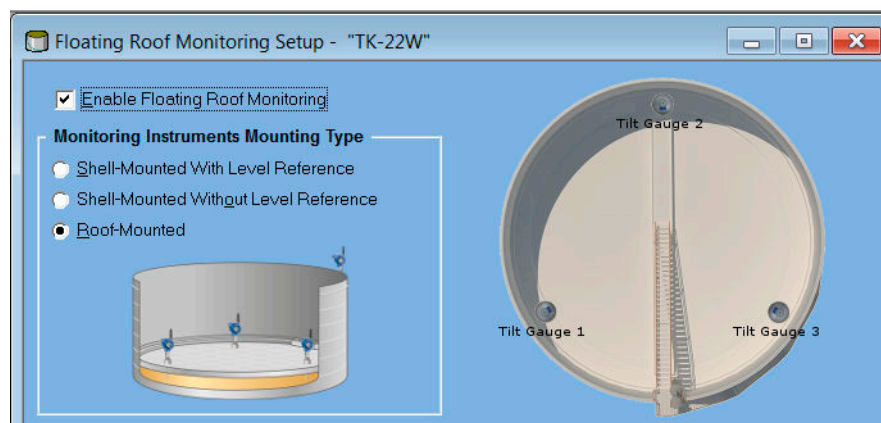

Tilt gauge configuration

You may use three to six tilt gauges. Prior to setting up the Floating Roof Monitoring function, make sure that the tilt gauges are properly installed and configured. Check that all tilt gauges are available and appear in the **Source** drop-down list.

Figure 3-9: Configuration of roof mounted tilt gauges

Number of Tilt Gauges		Level 20.200 m	
3			
Tilt Gauge 1			
Source	Wi-3308A		
Normal dist.	0.000 m		
Actual dist.	0.109 m		
Difference	-0.109 m		
Tilt Gauge 2			
Source	Wi-3308B		
Normal dist.	0.000 m		
Actual dist.	0.269 m		
Difference	-0.269 m		
Tilt Gauge 3			
Source	Wi-3308C		
Normal dist.	0.000 m		
Actual dist.	0.317 m		
Difference	-0.317 m		

Number of tilt gauges

Ensure that number of tilt gauges corresponds to the actual number of tilt gauges installed on the tank roof. You may use up to six tilt gauges.

Source

For each tilt gauge, select a gauge from the **Source** drop-down list. Tilt gauges appear in the TankMaster WinSetup workspace as shown in Figure 3-10.

Figure 3-10: Floating Roof Tank With Tilt Gauges

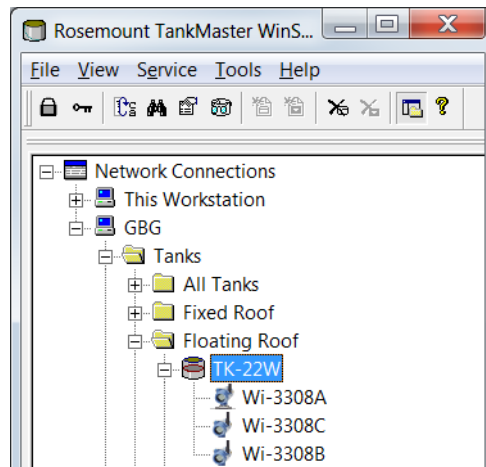

Normal distance

In the **Normal Distance** field, enter the actual distance value shown when the tank roof floats horizontally in its normal position. This value will be used as a reference value for roof buoyancy calculations.

The **Normal Distance** value is the actual distance the tilt gauge measures to the product surface when the roof floats horizontally in its normal position and without being tilted.

Figure 3-11: Calibrating Normal Distance for Roof Mounted Tilt Gauges

Number of Tilt Gauges		Level 20.200 m	
Tilt Gauge 1			
Source	Wi-3308A		
Normal dist.	0.109 m		
Actual dist.	0.109 m		
Difference	0.000 m		
Tilt Gauge 2			
Source	Wi-3308B		
Normal dist.	0.269 m		
Actual dist.	0.269 m		
Difference	0.000 m		
Tilt Gauge 3			
Source	Wi-3308C		
Normal dist.	0.317 m		
Actual dist.	0.317 m		
Difference	0.000 m		

Related information

[Geometry](#)

Alarm Setup

The **Alarm Setup** button in the *Floating Roof Monitoring Setup* window lets you configure alarm limits for roof tilt, roof floating high/low, and drain sump.

Related information

[Alarm setup](#)

3.2.6

Drain gauge

A drain gauge can be configured in the Floating Roof Monitoring system. Typically, a Rosemount 3308 transmitter or a wireless vibrating fork is used. Other suitable devices may be used as well and installed as generic device in TankMaster WinSetup.

Click the check box to enable drain sump measurements. You may choose one of two types of drain gauge as source device:

- level gauge
- On/Off switch

Figure 3-12: Enabling Drain Gauge

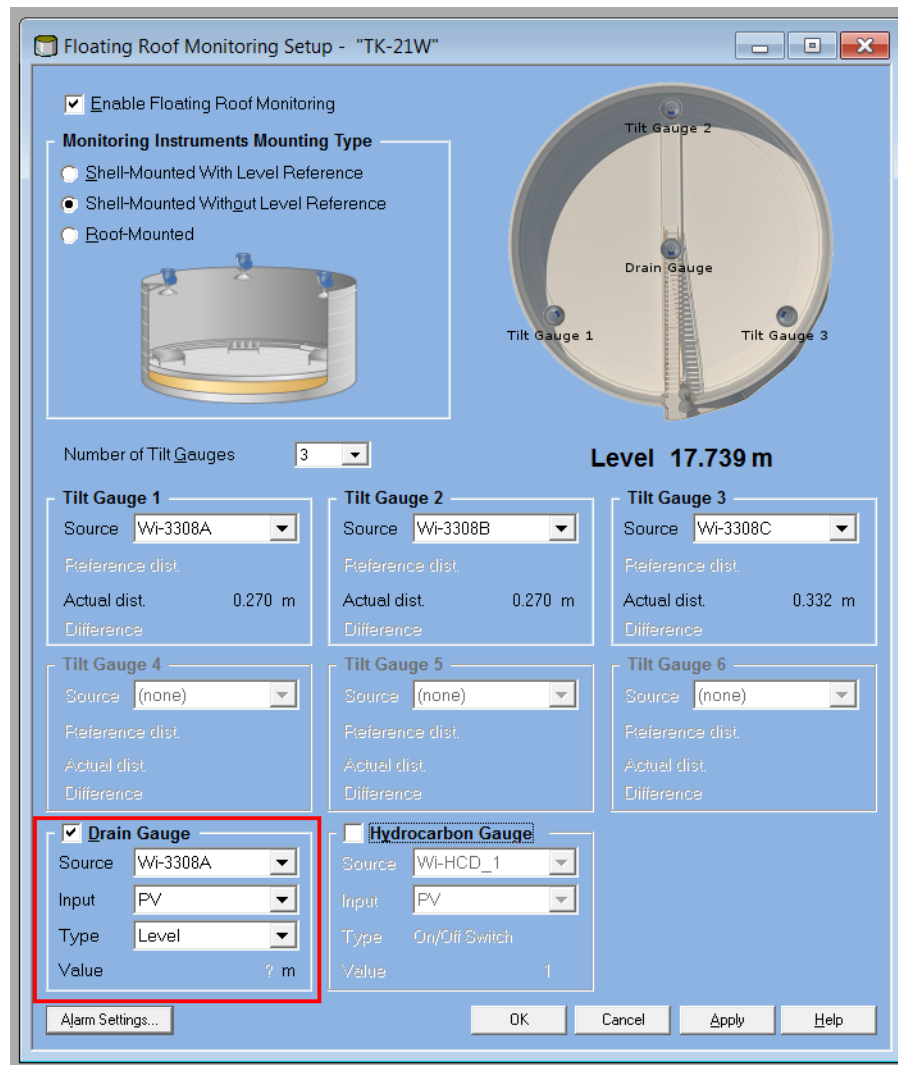

Figure 3-13: Drain Gauge Options

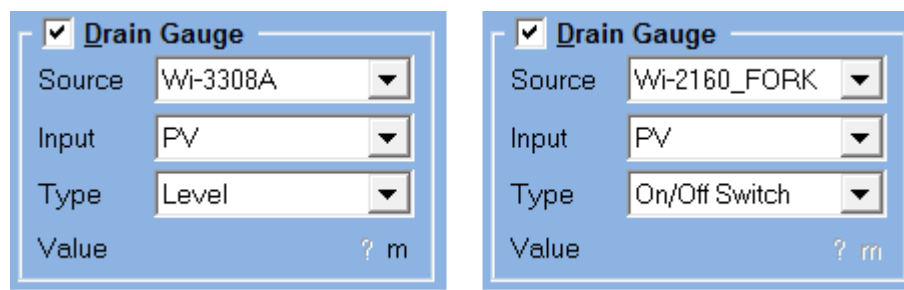

Table 3-4: Drain Gauge Configuration

Parameter	Description
Source	Level gauge or On/Off switch
Input	PV, SV, TV, QV
Type	Level or On/Off

3.2.7 Hydrocarbon gauge

hydrocarbon detecting transmitter can be configured to detect possible product leakage into the sump water from the tank roof drain. The transmitter must support *WirelessHART®* in order to be used in the Floating Roof Monitoring system. Typically, a Rosemount 702 Wireless Discrete Transmitter with Liquid Hydrocarbon Detection may be used.

Figure 3-14: Enabling Hydrocarbon Gauge

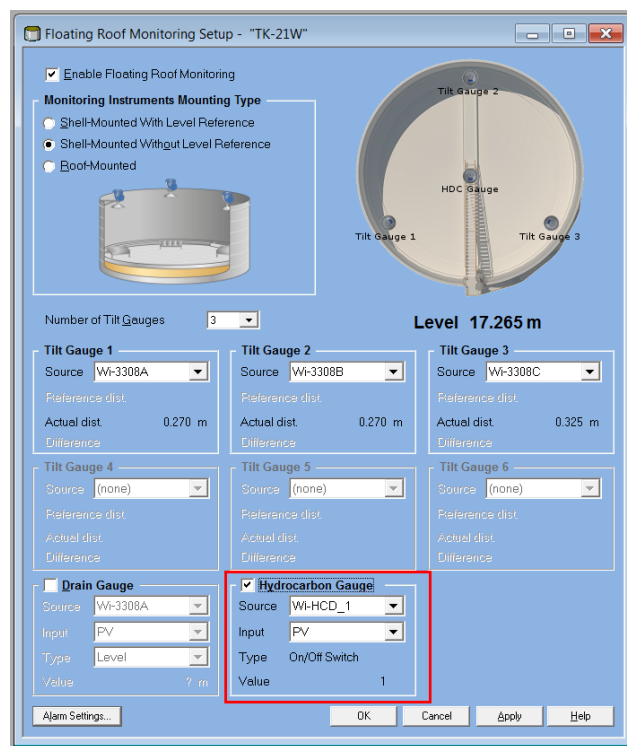

Figure 3-15: Hydrocarbon Gauge Options

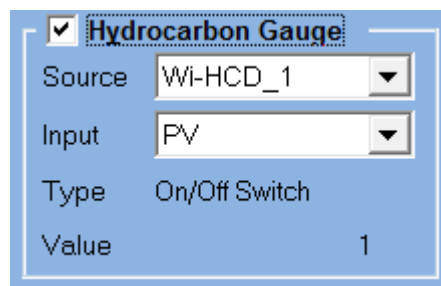

Table 3-5: Hydrocarbon Gauge Configuration

Parameter	Description
Source	Select a wireless device
Input	PV, SV, TV, QV
Type	On/Off switch

3.2.8 Alarm setup

Prerequisites

Requires hardware key option **Roof Monitoring Setup**.

Note

When using roof mounted Rosemount 3308 transmitters, ensure that **Blind Zones** are considered when specifying alarm limits.

Procedure

1. In the **Floating Roof Monitoring Setup** window, click the **Alarm Settings** button.

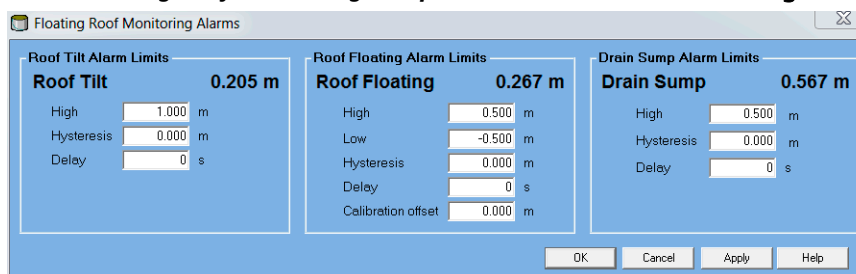

2. Enter the desired alarm limits. Available options may vary depending on mounting type and whether drain and hydrocarbon gauges are installed or not.

Related information

[Geometry](#)

Floating roof monitoring alarms

This is a brief description of available alarms in the **Floating Roof Monitoring Alarms** window.

Roof tilt

This alarm is used for setting the maximum allowed roof tilt. Hysteresis and delay can be used to handle temporary movements that may exceed alarm limit for short periods of time.

Roof floating

This option is available for **Shell-mounted with Level Reference** and for **Roof Mounted** installations.

The **Calibration offset** is added to all tilt gauges measuring on the tank roof. Use this offset to get a **float offset** (buoyancy) equal to zero in normal condition when the roof is freely floating and not tilting.

Drain sump

For drain gauge of level type, such as the Rosemount 3308 level transmitter, you may specify High alarm, Hysteresis, and Delay time.

For drain gauge of On/Off type you may specify Delay time.

Alarm limits

The detailed view of the **Floating Roof Monitoring** window may be helpful as a tool to find out how to set proper alarm limits for roof tilt and roof floating.

As the product level moves up and down, the **History** pane in the **Floating Roof Monitoring** window shows data of maximum roof tilt as well as minimum and maximum deviation of roof floating position. This may give you an idea of the range of roof tilt and floating positions, and provides useful input for specifying appropriate alarm limits.

Ensure that floating roof monitoring alarm limits are within the transmitter's measuring range as shown in [Figure 3-16](#).

Figure 3-16: Alarm Limits and Measuring Range for roof mounted

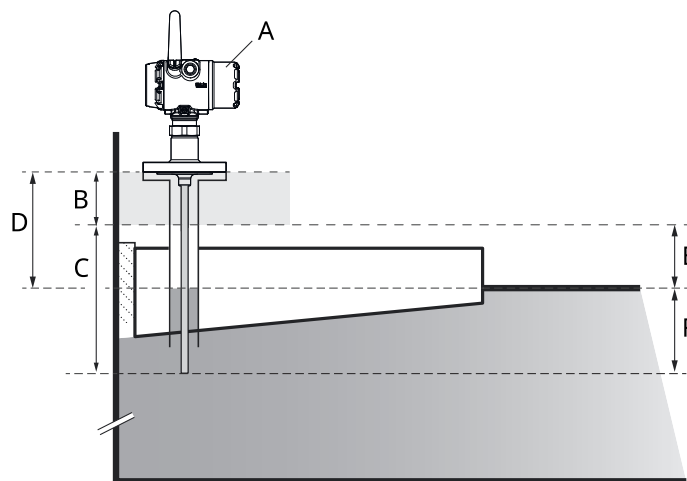

- A. Rosemount 3308 tilt gauge
- B. Blind Zone
- C. Measuring range
- D. Normal distance
- E. Roof Floating **Low** alarm zone
- F. Roof Floating **High** alarm zone

Related information

[Configure alarm limits](#)

[Floating roof alarm limits](#)

4 Operation

4.1 Open tank view

Tanks setup for Floating Roof Monitoring can be monitored in Rosemount TankMaster WinOpi.

Procedure

1. Ensure that Rosemount TankMaster WinOpi is up and running.
2. In the WinOpi workspace, click the right mouse button on the desired tank and select the **Floating Roof Monitoring** option.

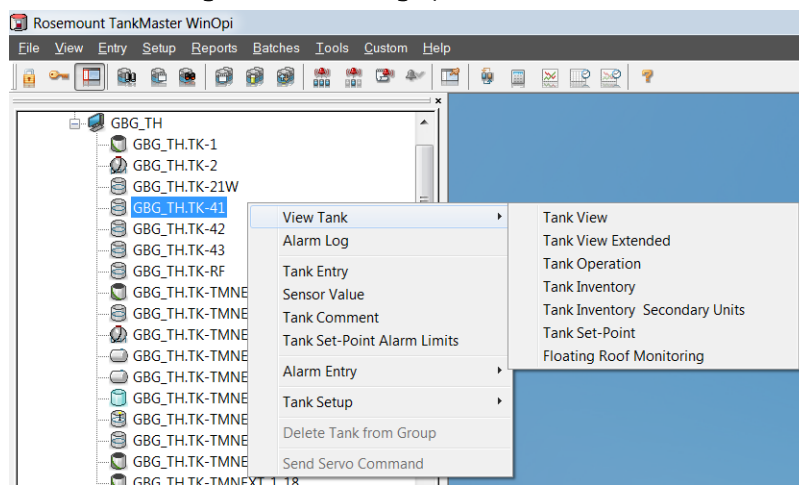

3. The **Floating Roof Monitoring** window presents the current status and measurement data.

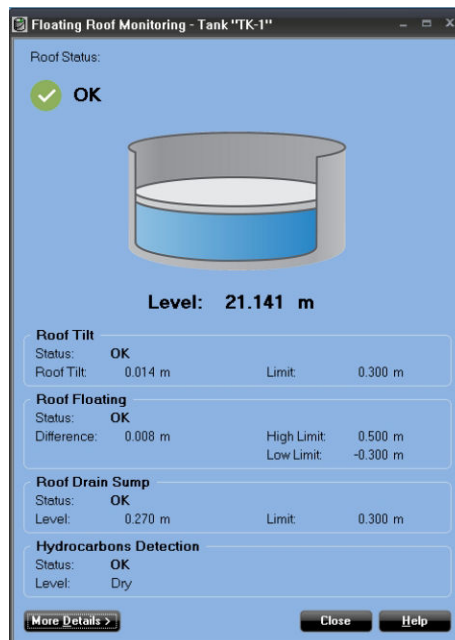

4. Select the **More Details** button to show tilt gauge data and historical data.
5. The **Roof Monitoring** window shows current roof status and historical data.

TK-01 - Roof Monitoring

Roof Status:
X Roof floating high

Level: **12.123 m**

Roof Tilt
Status: **OK**
Roof Tilt: **0.053 m** Limit: 0.100 m

Roof Floating
Status: **Roof floating high**
Difference: **0.123 m Hi** High Limit: 0.100 m
Low Limit: -0.100 m

Roof Drain Sump
Status: **OK**
Level: **0.053 m** High Limit: 0.650 m

Tilt Gauge	Source	Value	Difference
Tilt #1	LT-07	0.263 m	-0.068 m
Tilt #2	LT-08	0.331 m	0.000 m
Tilt #3	LT-09	0.399 m	0.068 m

History
Since **2016-12-05** Time: Level:
Tilt, max: **0.158 m** 2016-12-08 12:35 12.123 m
Floating, max: **0.165 m** 2016-12-21 18:48 6.547 m
Floating, min: **-0.003 m** 2016-12-06 05:31 3.154 m

< Fewer Details Close Help

4.2 Configure alarm limits

This instruction shows how to access alarm limit configuration for floating roof monitoring.

Procedure

1. Ensure that **Rosemount TankMaster WinOpi** program is up and running.
2. In the WinOpi workspace, select the desired tank.
3. Click the right mouse button and select **Alarm Entry** → **Alarm Limits**. The **Alarm Limits** window appears.
4. Click the **Roof Monitoring Alarm Limits** button to configure alarms for tilt, drain, and hydrocarbon gauges.

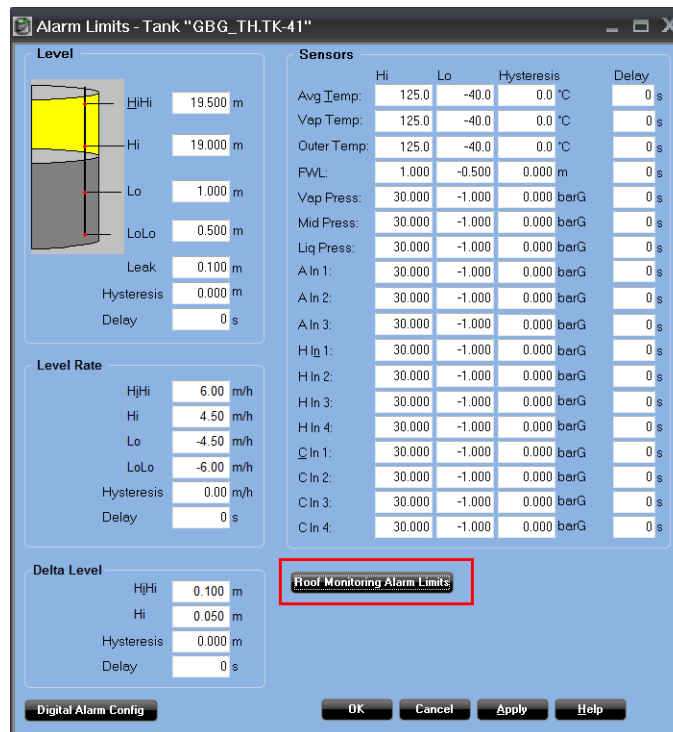

5. The **Floating roof Monitoring Alarms** window lets you configure limits for roof tilt, floating position, and drain sump.

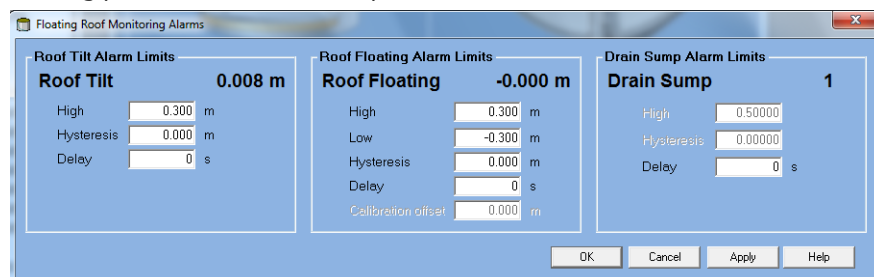

4.2.1 Floating roof alarm limits

Since each tank is unique, you will need to find proper floating roof alarm limits individually for each tank roof. The detailed view of the **Roof Monitoring** window may be helpful as a tool to find out how to set proper alarm limits for roof tilt and roof floating.

As the product level moves up and down, the **History** pane shows maximum roof tilt as well as minimum and maximum deviation of floating position. This may give you an idea of the range of roof tilt and roof floating which can serve as useful input for specifying appropriate alarm limits.

Make sure that alarm limits are configured within the transmitter's measuring range and that the product surface does not reach the **Blind Zone**.

The **Value** column shows the current tilt value.

The **Difference** column shows the deviation between current tilt value and the calibrated value as specified in the **Floating Roof Setup** window.

Figure 4-1: Detailed view in Roof Monitoring window

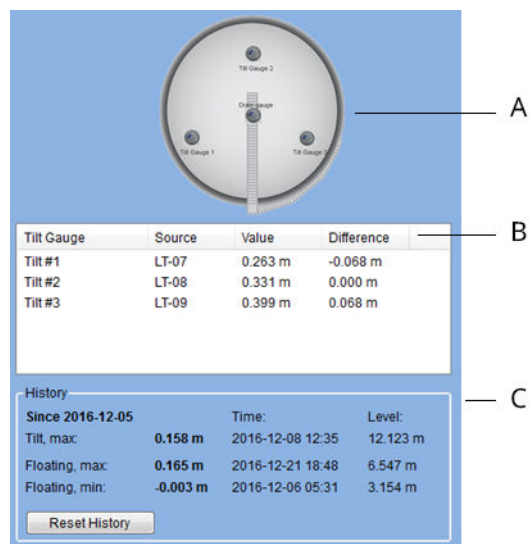

- A. Graphical view of tank and tilt gauge positions.
- B. Current tilt gauge data. Value=distance to product surface. Difference=deviation from Normal Distance.
- C. Historical tilt data.

4.3 Alarm disconnect

The **Alarm Disconnect** window lets you disconnect various tank variable alarms as well as Floating Roof Monitoring alarms such as Roof Tilt, Roof Floating, Drain Sump, and Hydrocarbon Detection alarms.

Procedure

1. In the WinOpi workspace, select the desired tank.
2. Click the right mouse button and select **Alarm Entry** → **Alarm Disconnect**.
3. Check the alarms to be disconnected.

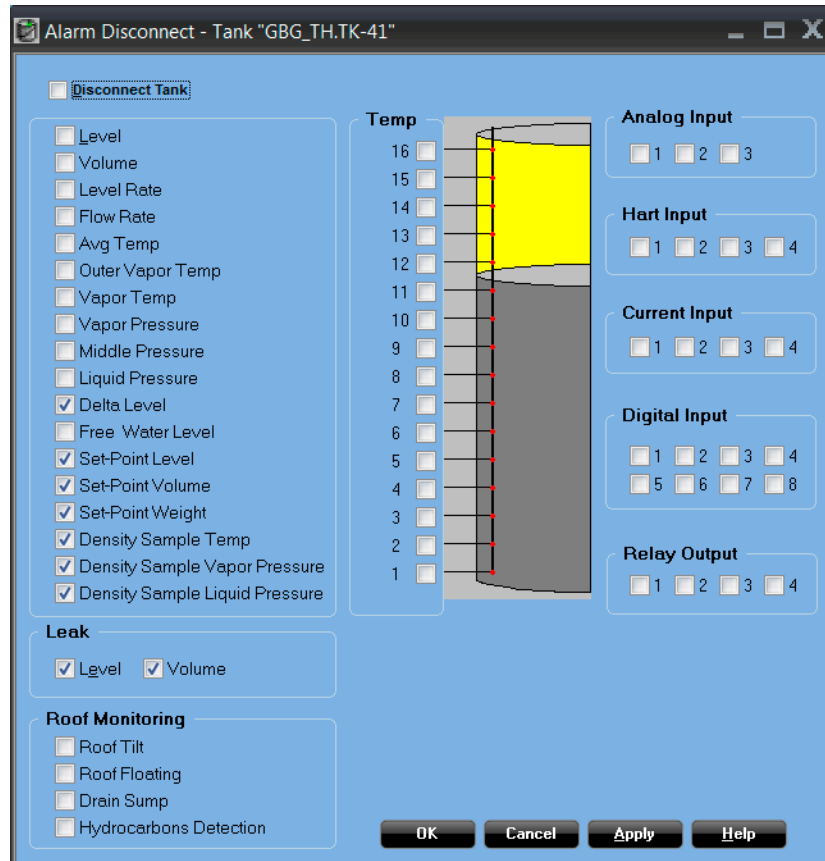

4. Click **Apply** to activate the disconnect function. Click **OK** to close the window.

4.4 Roof monitoring group view

In TankMaster WinOpi it is possible to create a specific group view for all tanks with roof monitoring function enabled. You can design the group view to include any particular floating roof parameters that you are interested in.

Figure 4-2: Group View in TankMaster WinOpi for floating roof monitoring

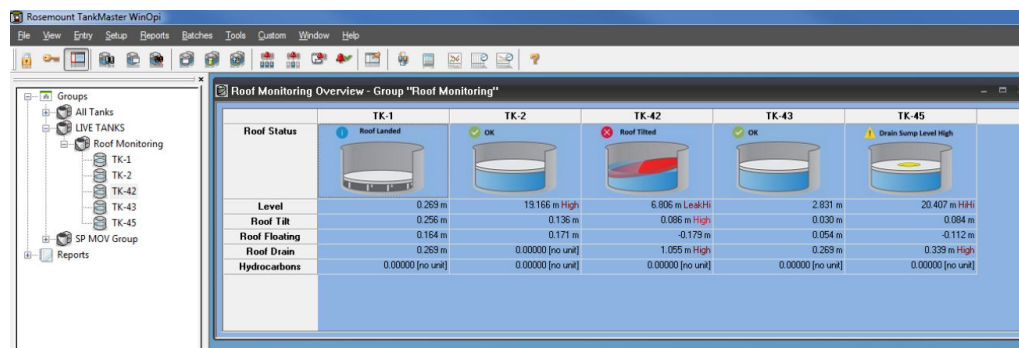
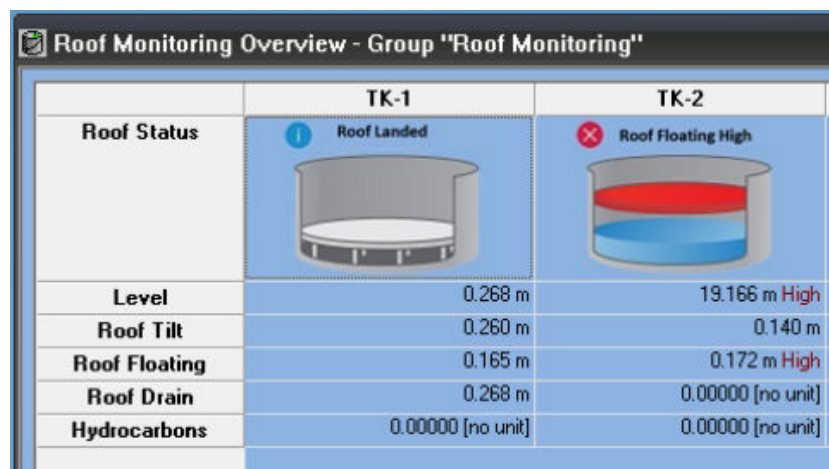

Figure 4-3: Floating Roof Monitoring Overview window



4.4.1 To create a group view

Procedure

1. Open the *Rosemount TankMaster WinOpi* program.
2. Open **Tools** → **Options**.
3. Select the **Group Templates** tab.

- In the left-hand column, select **View Group** and click the **Clone** button.

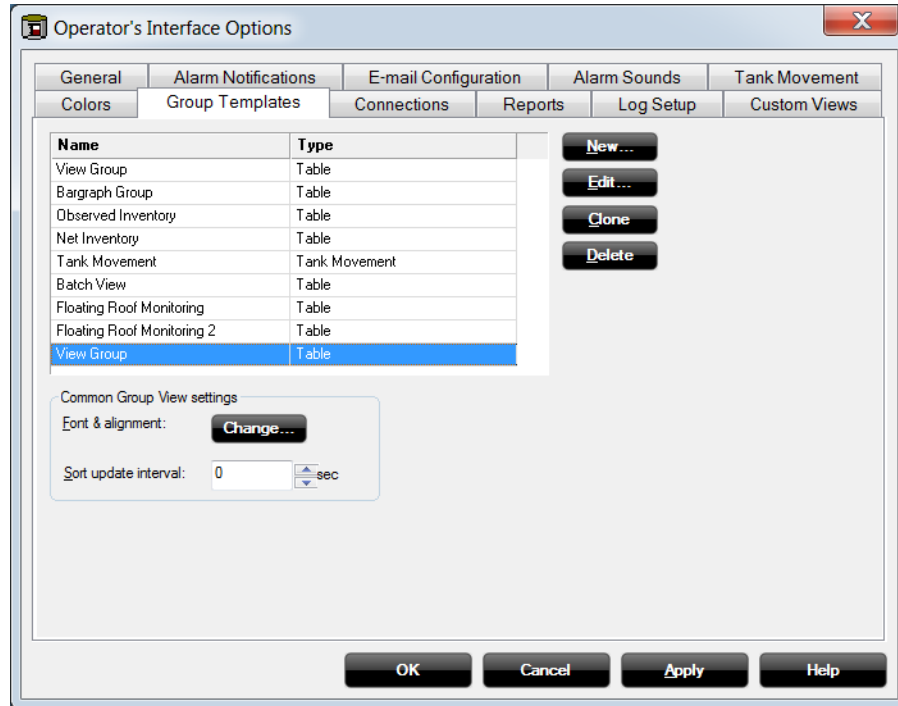

- Select the duplicated group template.
- Click the **Edit** button. Now the **Edit Group Template** window appears.

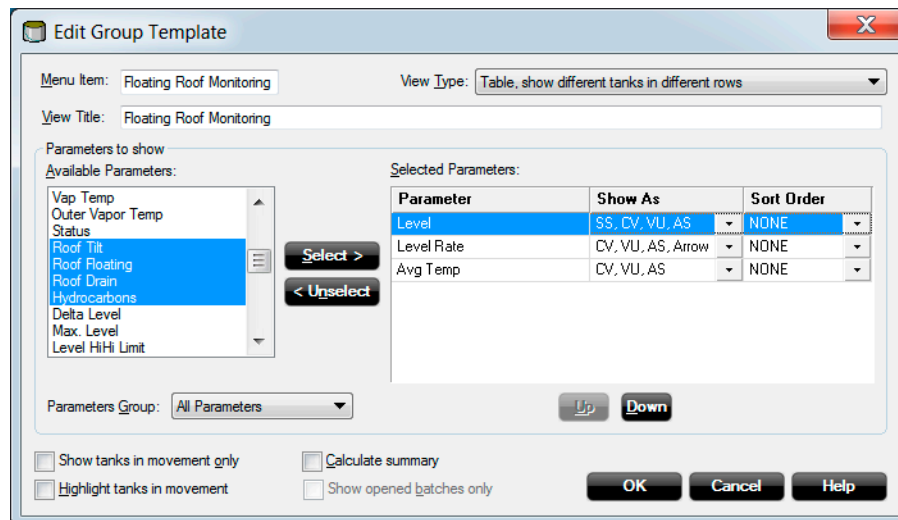

- Under **Menu Item** you may enter a title to appear under the **View** → **Group** menu. Under **View Title** you may type a title for the new group view.
- In the **Available Parameters** pane on the left-hand side, select the desired parameters to add to the new group view. In the above example Roof Tilt, Roof Floating, Roof Drain, and Hydrocarbons are selected. You may select several parameters at the same time by using the **Shift** or the **Ctrl** button and clicking the left mouse button. Available parameters for floating roof monitoring are:

- Roof Tilt

- Roof Floating
- Roof Drain
- Hydrocarbons
- Roof Status

9. Click the **Select** button to move the parameters to the **Selected Parameters** pane.

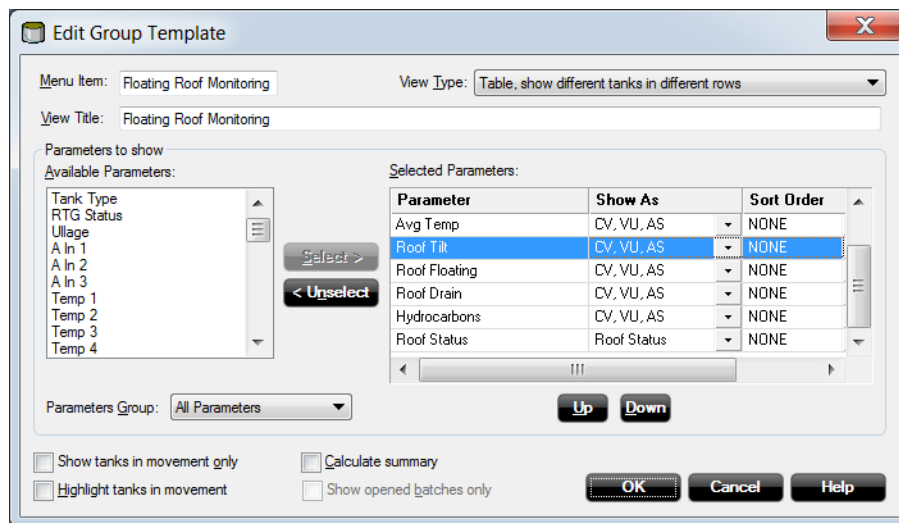

10. Click **OK** to close the **Edit Group Template** window.

11. Click **OK** to close the **Options/Group Templates** window.

4.5 Roof monitoring historical data

The **Historical View** window lets you view roof floating and roof tilt history.

Prior to viewing historical data you will have to specify which parameters and tanks to sample and start the actual data sampling (Sample Setup). You will also have to configure how historical data is presented (View Setup).

The **Sample Setup** button lets you configure what tanks and parameters to be sampled.

The **View Setup** button lets you configure how tank parameters are displayed in the Historical View window.

Figure 4-4: Historical View



4.5.1 Sample setup

The **Sample Setup** window lets you specify which parameters to sample for the **Historical View**. This is a brief overview of sample setup. See the [Rosemount TankMaster WinOpi reference manual](#) for more information.

Figure 4-5: Historical View Sample Setup

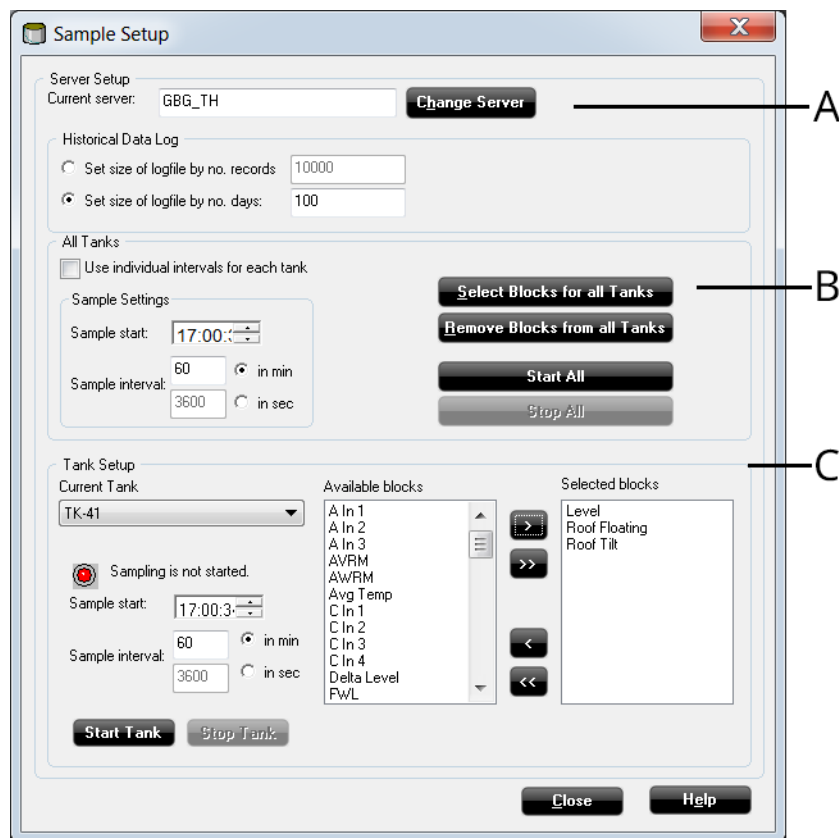

- A. Server Setup
- B. All Tanks
- C. Tank Setup

Server setup

Allows you to select a TankMaster server.

All tanks

Allows you to select blocks and to configure sample interval and start time for all tanks.

Tank setup

Lets you select tank and blocks to be monitored, and to configure sample interval and start time for individual tanks. In addition to the standard blocks, the following blocks are available for floating roof monitoring:

- Roof Floating
- Roof Tilt

- Roof Drain

Starting and stopping data sampling

You may start sampling all tanks at once by pressing the **Start All** button. In case you would like to start the current tank only, press the Start Tank button.

Figure 4-6: Sampling started

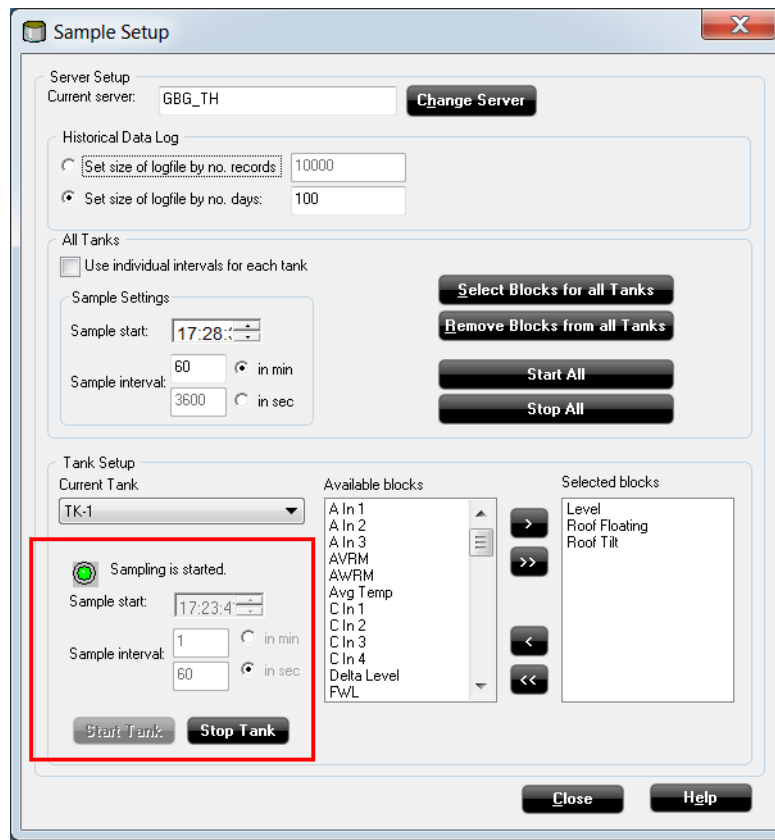

4.5.2 View setup

The **View Setup** window lets you configure how tank parameters are displayed in the **Historical View** window. See the Rosemount TankMaster WinOpi [reference manual](#) for more information on how to set up presentation of historical data.

4.6 Roof status

The **Floating Roof Monitoring** window shows the current status of the floating tank roof. Each condition is presented with an image and text that presents tilt, roof floating high/low, hydrocarbon, and drain sump.

OK

Good. Status is OK.

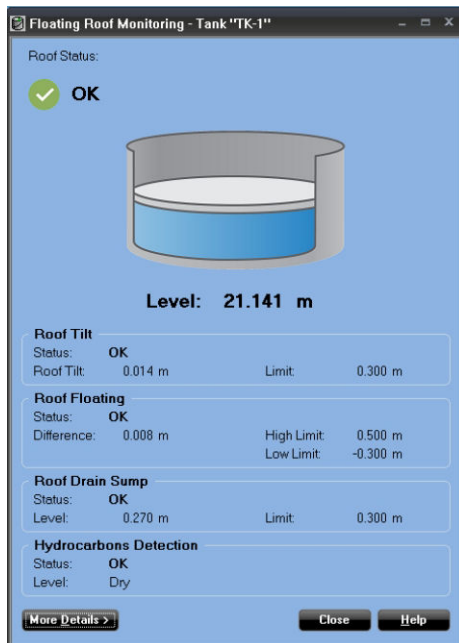

Roof Tilted

Roof tilt exceeds alarm limits. Roof might be stuck or one or several pontoons may be damaged.

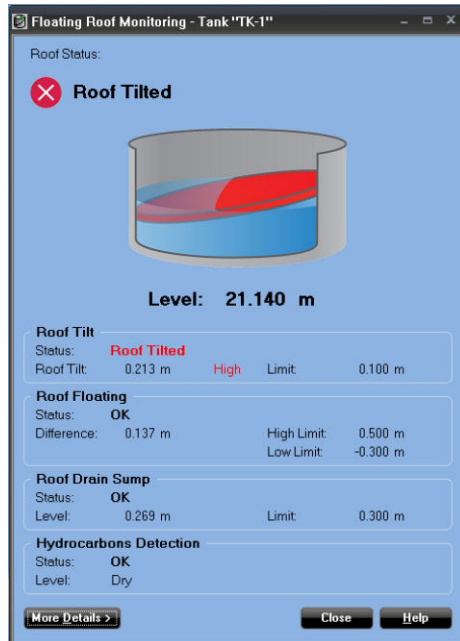

Roof Floating Low

Roof is floating lower than configured alarm limit. There may be product or water on top of the roof, or pontoons may be damaged.

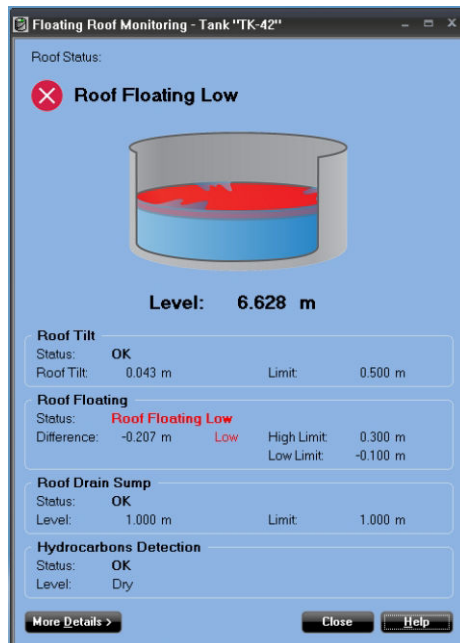

Roof Floating High

Roof is floating higher than configured alarm limit. The roof might be stuck.

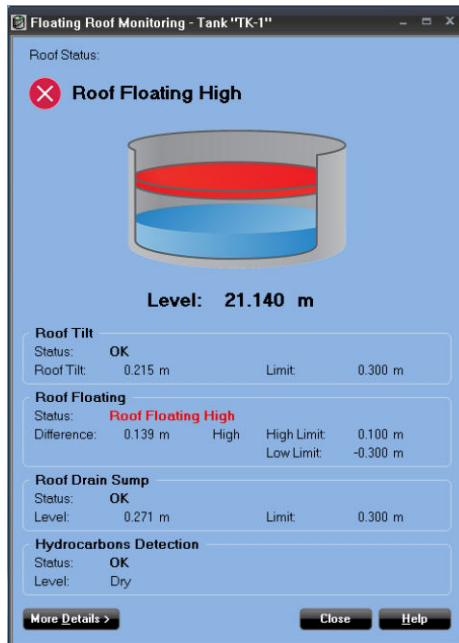

Hydrocarbon Detected

Product may have leaked to tank roof.

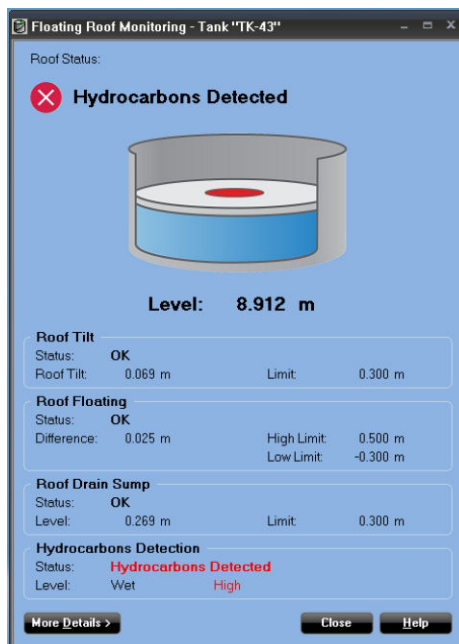

Drain Sump Level High

Drain sump may be clogged.

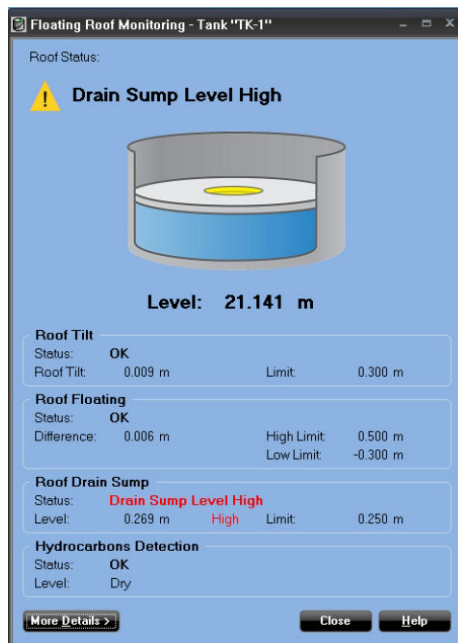

Unknown

Incorrect configuration or invalid data from one or several transmitters.

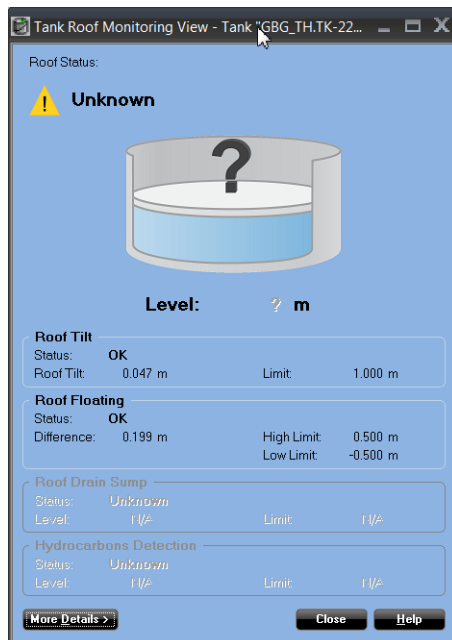

Roof Partially Landed

Roof partially landed.

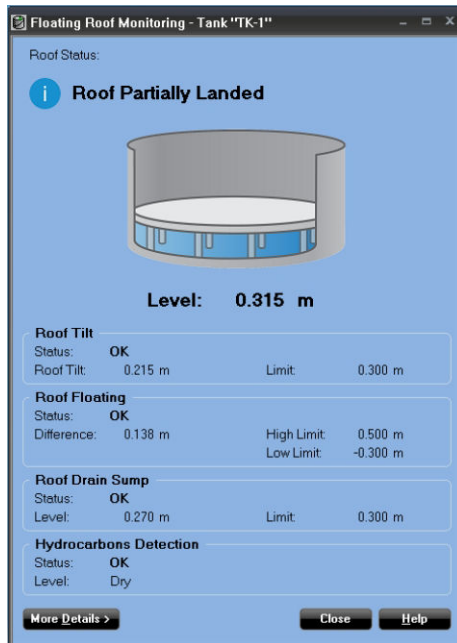

Roof Landed

Roof landed.

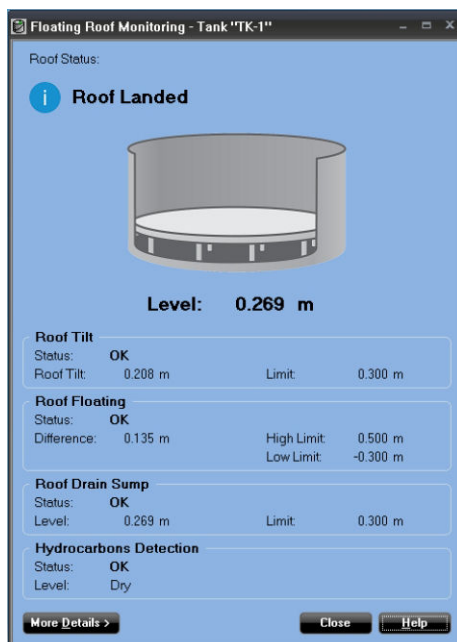

4.7 Alarm priority

The various status options are displayed in an order that depends on their respective priority as listed in [Table 4-1](#).

Table 4-1: Alarm Priority for Floating Roof Status

Priority	Status
1	Roof tilted
2	Roof Floating High/Low
3	Hydrocarbons Detected
4	Drain Sump Full
5	Unknown
6	Roof landed/partially landed
7	OK

5 Service and troubleshooting

5.1 Troubleshooting

This troubleshooting chart covers issues related to floating roof monitoring. For other issues see the reference manual for the respective device.

5.1.1 Alarm is not triggered as expected

Possible cause

Incorrect alarm limit configuration.

Recommended action

Make sure that alarm limits are properly set. You may use detailed view in the **Roof Monitoring** window to use historical data as input to find the appropriate alarm limits.

5.1.2 Roof floating low/high reversed sign

Possible cause

Primary variable (PV) configured as Level for the Rosemount 3308 transmitter.

Recommended action

Configure **Primary Variable** to **Distance** (PV=Distance).

5.1.3 Status unknown

Symptom

Status "Unknown".

Possible cause

- Incorrect inventory setup
- Communication failure
- Invalid level
- Configuration error
- Incorrect configuration or invalid data from one or several transmitters.

Recommended actions

- Check gauge status for tilt gauge, drain gauge, and hydrocarbon gauge
- Check floating roof status in **Tank Inventory** window
- Check Tank Capacity Table (TCT)
- Check Average Temperature
- Check inventory configuration in **Tank Inventory** window

5.1.4 False High/Low alarms for floating roof

Possible cause

Incorrect tank geometry configuration for reference level gauge.

Recommended actions

Make sure that tank geometry is configured with correct values.

Possible cause

Measurement updates from tilt gauges out of sync.

Recommended actions

- Add alarm delay time
- Change alarm limit
- Increase update time for tilt gauges

Possible cause

A reflector is moved out of correct position.

Recommended actions

Make sure that each reflector is properly placed under the tilt gauge.

Possible cause

Tank roof has landed on its support legs.

Recommended actions

Normal function. TankMaster does not automatically disable floating roof high alarm when tank roof has landed.

Possible cause

Hardware error. Wrong transmitter head is mounted on probe after maintenance.

Recommended actions

Make sure that the transmitter head is mounted on the correct probe and roof position.

5.1.5 Wireless network is slow and unstable

Possible cause

- Low battery in one or several wireless devices
- One or several wireless devices off line
- Wireless field network does not comply with IEC 62591 (WirelessHART®) best practice

Recommended actions

- Verify battery status by e.g. using the gateway web interface
- Verify that all wireless devices (including repeaters) are online
- Verify wireless network communication according to IEC 62591 (WirelessHART) standards best practice.

A Commissioning Checklist

This check list may be used as a tool to ensure that you have walked through all steps of the Floating Roof Monitoring setup.

Table A-1: Checklist

Item	Description	See section
1	Verify all mechanical requirements.	<ul style="list-style-type: none"> • Installation on tank shell • Installation on tank roof
2	Make sure that all transmitters are configured: <ul style="list-style-type: none"> • Communication • Tank geometry • Device specific data 	See reference manual for respective transmitter.
3	Verify tilt gauge and reference level gauge measurements. Hand dipping is recommended to ensure that level readings are correct.	N/A
4	Configure alarm limits for floating roof monitoring. Verify that alarm limits are properly setup relating to maximum roof tilt and roof floating high/low.	<ul style="list-style-type: none"> • Alarm setup • Floating roof alarm limits
5	Make sure that maintenance schedule includes verifying wireless network regularly.	<ul style="list-style-type: none"> • IEC 62591 (<i>WirelessHART</i>[®]) • Rosemount Tank Gauging Wireless System Reference Manual

For more information: [Emerson.com/global](https://emerson.com/global)

©2024 Emerson. All rights reserved.

Emerson Terms and Conditions of Sale are available upon request. The Emerson logo is a trademark and service mark of Emerson Electric Co. Rosemount is a mark of one of the Emerson family of companies. All other marks are the property of their respective owners.

ROSEMOUNT™

