

DeltaV Safety Instrumented System (SIS)[™] with IS Electronic Marshalling

- Intrinsically Safe I/O anywhere you need it
- Integrated galvanic isolation per channel
- Optimized process reliability
- Simplified safety lifecycle management
- Flexibility to meet project needs
- Reduces installed cost of system
- Field mounted capable hardware

Introduction

The DeltaV SIS[™] process safety system has a uniquely scalable modular architecture that is based on the CHARMs Smart Logic Solver (CSLS) and the unprecedented flexibility and ease of use of the Emerson Electronic Marshalling solution. Each CSLS provides I/O processing, SIL 3-capable logic solving, and diagnostics in a single logic solver. The CSLS supports up to 96 individually configurable channels, allowing flexibility for implementing safety instrumented functions and is designed specifically for multi-core home run cables or field junction box installation. All communications are completely redundant from the channel (LS IS CHARM) to the CSLS. Integrated HART[®] I/O brings field diagnostics into the CSLS.

The addition of Intrinsically Safe (IS) LS CHARMs provides significant savings in system design, installation cost, and ease of maintenance expected with Electronic Marshalling, with the added safety for field wiring to hazardous areas. The reduced footprint and associated elimination of separate barriers and the associated inter cabinet wiring makes for a more robust installation with significant cost savings.



The DeltaV SIS[™] process safety system has the world's first CSLS, using the power of predictive intelligence to increase the availability of the entire safety instrumented function in combination with the advantages of the Emerson Electronic Marshalling solution, using IS LS CHARMs.

Benefits

Optimized process reliability. Emerson has extended the benefits of the PlantWeb® architecture to SIS, with DeltaV SIS using Intrinsically Safe (IS) LS CHARMs being a key component of the Smart SIS solution. Research shows that more than 90% of all faults in SIS applications occur in field instruments and final elements. The DeltaV SIS process safety system has the world's first Smart Logic Solver using LS IS CHARMs. It communicates with intelligent field devices using the HART protocol to diagnose faults before they cause spurious trips. This approach increases process availability and reduces lifecycle costs.

Flexibility to meet project needs. Whether you have an isolated wellhead or a large emergency shutdown device (ESD) application, the DeltaV SIS system scales to provide you with the safety coverage you need for your SIL 1, 2 and 3 safety functions. Each CSLS provides I/O processing, SIL 3-capable logic solving, and diagnostics. This means that processing power is added as the system expands, and no additional processors will ever be required. Scan rate and memory usage are constant and independent of system size.

Modularity also provides isolation of safety instrumented functions (SIFs). This isolation eliminates single-points of failure for improved availability and safety integrity.

The DeltaV SIS system looks for new hardware every scan, so equipment can be added to a running system in real time. Online addition of new logic solvers will not interrupt your process.

Simplified safety lifecycle management. The DeltaV SIS CSLSs are SIL 3-rated for both simplex and redundant architectures. Redundant pairs of CSLSs can be installed for increased process availability of your SIFs.

Intrinsically Safe I/O anywhere you need it. The DeltaV SIS CSLS provides an unprecedented flexibility in safety system I/O topology. Using standard Ethernet infrastructure hardware you can add safety related I/O anywhere you need it. From a local I/O cabinet to remote enclosures miles away, simply install the CSLS and connect it to the LSN. Each CSLS can read the input signals from any other CSLS on the same LSN every 50 ms, the same as the inputs wired directly to its own LS IS CHARM system.

Integrated galvanic Isolation per channel, each I/O channel has a dedicated LS IS CHARM that provides both signal characterization and galvanic isolation for intrinsically safe applications. IS barriers are integrated

inside the LS IS CHARM to provide single channel fault isolation as well as electrical isolation and energy limiting circuitry that meets IEC Ex ia ratings.

Reduces installed cost of system. DeltaV SIS Electronic Marshalling helps reduce overall system costs by eliminating internal cabinet cross wiring, reducing overall footprint, simplifying SIF design, and reducing Factory Acceptance Test (FAT) activities. Electronic Marshalling provides separation between I&E hardware installation schedules and SIF development. Wiring can begin earlier knowing any late changes can be done without lifting a wire. The ability to read any input on the LSN allows more efficient cabinet designs and accommodates late scope changes to add I/O anywhere. Adding additional SIF capacity does not require re-wiring I/O. Simply read the I/O signals from the proper CSLS, without lifting a wire.

Fully redundant communications. The CSLS architecture is fully redundant. It starts with the two logic solvers on a carrier. The carrier has redundant Safety Network Ports (SNP) for communication with primary and secondary LSN connections. There are two 24V DC input power connections. The carrier connects to the CHARM baseplates providing redundant power and communication buses to the LS IS CHARMs. Everything is redundant down to the individual channel.

Field mounted capable hardware. All components of the CSLS are rated for installation in Class 1/Div 2 or Zone 2 hazardous locations. The extended operating temperature ranges and G3 environment rating allows them to be installed in field mounted junction boxes. This further reducing the footprint required in central equipment rooms, as well as reduces the overall wiring infrastructure of traditional multi-core instrumentation cable.

Plug and Play I/O. The DeltaV SIS CSLS has been designed for ease of use, both in physical installation and its software tools. Components snap together with secure DIN-rail latches and interlocking carrier connectors. Attach a series of 96 I/O channels to a DIN-rail in a matter of minutes. Insert the LS IS CHARMs and auto sense the node to create the I/O definition automatically in your DeltaV SIS configuration database. LS IS CHARMs use a self keying system to automatically set a channel for a specific LS IS CHARM type. Users cannot mistakenly insert a LS IS CHARM into the wrong terminal block.

Field power is provided through a redundant 24V DC bus to each LS IS CHARM. Each LS IS CHARM provides galvanically isolated field power through an internal isolation transformer, eliminating external wiring to barriers.

Product Description

CHARM Smart Logic Solvers

The original CHARM Smart Logic Solver (CSLS) was introduced with DeltaV v12 in 2013. Beginning January 2026, a redesigned Smart Logic Solver Plus (CSLS+) will be available.

While CSLS+ is intended to replace the original CSLS, the initial release has the following limitations:

- Compatible only with firmware revision 2
- Supported only in redundant configurations with another CSLS+
- Intended exclusively for new installations at this time

SIF-based Approach

The DeltaV SIS system design was based on IEC 61511 SIF concept, where every logic solver is a container for a small number of SIFs. Unlike other system architectures, with modular logic solving architecture, the logic solver is no longer a single point of failure for the entire process. If failures were to occur, only the equipment tied to the logic solver would be affected.

The DeltaV SIS SIF-based approach does not mean that all of the safety logic and I/O have to fit into one logic solver. All input data is made available to every logic Solver on the LSN every 50ms the same as the local inputs on every CSLS.

With DeltaV SIS logic solvers, neither the scan rate nor the execution of a SIF is altered by changes or additions to another SIF. DeltaV SIS logic solvers always execute deterministically, every 50 ms, regardless of how much I/O is running on the system.

Redundancy

The redundant logic solvers include two CSLSs installed side-by-side on the CSLS Carrier. The CSLS Carrier has redundant power and communication connections to the baseplates that are wired to the field devices. Each CSLS of the redundant pair has a separate power supply.

No control strategy configuration is required to take advantage of CSLS redundancy because the DeltaV SIS auto-sense capability automatically recognizes the redundant pair of cards.

When redundancy is chosen, the two CSLSs run in parallel at all times. Both read the inputs from the I/O terminals, both execute the logic and both drive the outputs at the I/O terminals. There is no concept of primary and backup or master and slave, which is unlike any other safety system.

The only difference between the two CSLSs is that one communicates with the engineering and operator workstations as well as the dedicated LSN. This CSLS has the Active light illuminated. The other CSLS is communicating only with the LSN.

Logic Solver Switchover

In the event that a failure is detected in one of the CSLSs, the CSLS will automatically go into a failed state. In this condition, there is no impact to the partner CSLS or the physical outputs. The partner CSLS continues to read inputs, execute logic, and drive outputs. The transition from redundant to simplex is completely bumpless.

Both logic solvers in a redundant pair are monitored for integrity alarms at all times, and an integrity error in either CSLS will notify the operator of a failure. Events that can cause integrity alarms include:

- Hardware failure within a logic solver,
- Communications failure between a logic solver and the LSN,
- Communications failure between a redundant pair of logic solvers, and
- Removal of a logic solver from the carrier.

The health and status of both logic solvers and their channels are available in the Diagnostics Explorer.

When one CSLS of a redundant pair of logic solvers is removed online, there is no disturbance to the process. When the missing CSLS is replaced with another, the new CSLS completes its power-up self-tests before the active CSLS cross-loads the current database. In safe areas, failed CSLSs can be replaced under power. In hazardous areas, appropriate installation procedures must be followed.

In the initial release, CSLS+ supports redundancy only when paired with another CSLS+. Mixed redundant pairs (CSLS and CSLS+) will be supported in a future release. The redundancy behavior of CSLS+ is identical to that of the original CSLS.

Online Proof Testing

Online proof testing can be performed on a redundant pair of logic solvers. The desired proof-test interval is set in the configuration. The logic solvers perform the proof test automatically, with a warning provided to the operator before the automatic proof test is started.

Diagnostics

The DeltaV SIS logic solvers execute extensive self-testing on a continuous basis to detect potential faults. Faults detected by logic solver diagnostics can be associated with the logic solver itself or associated with field devices, field wiring, or other conditions not related to hardware.

DeltaV SIS provides standard alarms to annunciate faults detected by logic solvers in the operator interface. No special configuration is required. When a diagnostic alarm occurs, it appears on the alarm banner of the operator interface. The operator is shown the type of alarm (failed, maintenance, etc.), as well as text for the active condition or “multiple conditions” if more than one alert condition is active for the particular alarm.

Sequence of Events Capability

With DeltaV SIS, events are automatically generated as function blocks are executed within a module scan. Events are time stamped with a resolution of <1 ms, and they are recorded in the sequence that they occur in the Event Chronicle. When using standard function blocks such as input blocks, voter blocks, and cause and effect blocks, a standard set of events are automatically generated without special configuration or programming required. For example, I/O failures, trip limits, first-outs, and other similar events are automatically time stamped by function blocks and recorded in the Event Chronicle. When a process variable exceeds the trip limit, DeltaV SIS records the event along with the analog value and the trip condition.

In general, when there is a plant event that triggers an ESD from the SIS, one input will exceed a trip limit on one scan and this will cause outputs to trip and more inputs will then change state. Sequence of Events Recording has been used to find that first input that caused the trip by looking at all of the inputs in the plant. With the DeltaV SIS system, the operator simply filters the Event Chronicle for first-out trips, and the first-out is clearly visible.

If higher resolution is required for some channels then they can be wired to both the DeltaV SIS Logic Solver and also to a DeltaV Discrete Input Card for Sequence of Events, which provides a resolution of 0.25 ms.

Integrated HART

Integrated HART I/O brings field diagnostics into the logic solver. Field device diagnostics information is not just for pass-through to AMS Device Manager; it is available inside the logic solver.

The DeltaV SIS logic solver can also generate HART commands to initiate a partial stroke test in a digital valve controller. The operators can initiate partial stroke tests manually from their operator workstations or they can be scheduled to occur automatically based on the specified test interval. The results from these tests are captured and integrated with the system event history. An alarm can be generated if a partial stroke test fails, alerting maintenance that there is a potential problem with a valve.

DeltaV SIS Electronic Marshalling Hardware Includes:

- CSLS Carrier (DIN rail mounted and supports a redundant pair of CSLSs, redundant 24V DC power connectivity, and redundant Ethernet Safety Network communication Ports).
- CSLS (provides redundant safety logic processing and communication to up to 96 LS IS CHARMS).
- IS CHARM base plate (DIN rail mounted with interleaving power and bus connectors. Supports 12 LS IS CHARMS and their terminal blocks).
- IS CHARM Terminal Block (removable terminal block providing terminal connections to field wiring and physical latch for LS IS CHARM).
- LS IS CHARMS (Logic Solver Characterization Module for each field signal. Provides basic analog to digital conversion and signal isolation to the redundant communication bus).
- Cable Extenders that provide flexibility in carrier mounting.
- I/O bus termination (provides bus terminations for redundant I/O bus).
- Labeling features for base plate and channel identification.

Intrinsically Safe (IS) LS CHARMS are designed to meet IEC EX ia level of safety and are suitable for connecting to field devices installed in Class 1 Division 1 Hazardous Locations or Zone 1/0 Hazardous Areas. The CSLS and LS IS CHARMS are rated for installation in a Class 1 Division 2 Hazardous location, a Zone 2 hazardous area or in the safe area.

The CSLS carrier is mounted to the top of a vertical DIN rail and up to eight IS CHARM Baseplates are mounted below it, snapping easily to the DIN rail as they are connected to each other. The bus termination assembly is attached at the bottom. A standard DIN-rail lock is used to keep the entire assembly in place.

A pair of CSLSs installs on the carrier and communicates over a redundant Ethernet safety network with up to 15 other CSLSs and 1 SZ controller, allowing great flexibility and ease of system expansion. Safety Network Ports are available for copper only.

SZ controllers connect to both the area control network and the LSN to isolate the CSLSs from the process control system. The SZ controllers has replaceable Ethernet Isolation Ports for connection to both LSN and the DeltaV Area Control network. Starting in DeltaV v14.3 a new Keylock Ethernet Isolation Port, in yellow color plastic, which enable the key inhibit unlock switch on the carrier to allow the key to inhibit the unlock command to all CSLSs on the LSN.

Only DeltaV SIS Smart Switches are supported on the LSN.

Each IS baseplate is ordered pre-loaded with 12 IS terminal blocks that are ready to receive field wires from two-, three-, and four-wire devices. Electronic Marshalling eliminates the need to partition the I/O wiring to specific channels based on signal type. Simply connect field signal multi-cores in an orderly fashion as desired. Install the appropriate LS IS CHARM to complete the field circuit and the signal is ready to be used by the CSLS. No cross-wiring required.

All LS IS CHARMS are energy limited devices that prevent the possibility of an explosion, even if wires are accidentally shorted together. In addition, each LS IS CHARM acts as a circuit protection device and field wiring disconnect. Each LS IS CHARM provides surge protection to meet industry standards in the area of EMC. Under extreme overvoltage conditions due to incorrect field wiring, the LS IS CHARM will act as a fuse to protect adjacent channels. Signal faults are thus isolated to the single LS IS CHARM.

LS IS CHARMS can be partially ejected to a locked position that disconnects the field wiring from the system to perform field maintenance actions or to remove power to a field device. Activating the LS IS CHARM latch ejects the LS IS CHARM to the detent position. Closing the latch locks the LS IS CHARM in place and isolates the field wiring for field work.

IS baseplate extenders and cables provide great flexibility to the IS CHARM installation in existing cabinets or in custom enclosures. Cables are redundant, each carrying 24V DC field power, 6.3V DC LS-CHARM power and one of the communication busses.

Bus termination provides added robustness for the communication bus and is installed at the end of the physical bus.

Label features are available to identify channel usage and baseplate identification to help with maintenance.

LS IS CHARMS can be added to any existing baseplate position and autosensed online. Additional CSLSs can be added online.

LS IS CHARM Types

A variety of analog and discrete LS IS CHARMS are available to meet your specific requirements.

- LS IS AI 4-20 mA HART
- LS IS DI NAMUR
- LS IS RTD
- LS IS Thermocouple/mV

All LS IS CHARMS have a bi-color Power/Integrity LED that indicates the health of the LS IS CHARM. The indications provide clear, actionable instruction to the maintenance personnel.

Green Solid: Normal Operation

Green Blink: Normal awaiting configuration

Red Blink: Fault detected on wiring

Red Solid: Internal Fault detected]

Discrete LS-CHARMS have a Yellow LED to indicate the state of the field signal. (On = circuit is energized)

All LS-CHARMS meet ISA 71.04-1985 severity level G3 (harsh) corrosion specifications

I/O Terminal Block Options

LS IS CHARMs are designed to work with the IS Terminal Blocks, which are light blue in color, designating the field wiring as intrinsically safe. LS IS CHARMs are mechanically different and will not install in non-IS terminal blocks, ensuring there is no error in the installation.

There are two different IS Terminal blocks available to meet the wiring needs of field signals.

- IS Standard Terminal Block
- IS Thermocouple / mV Terminal Block

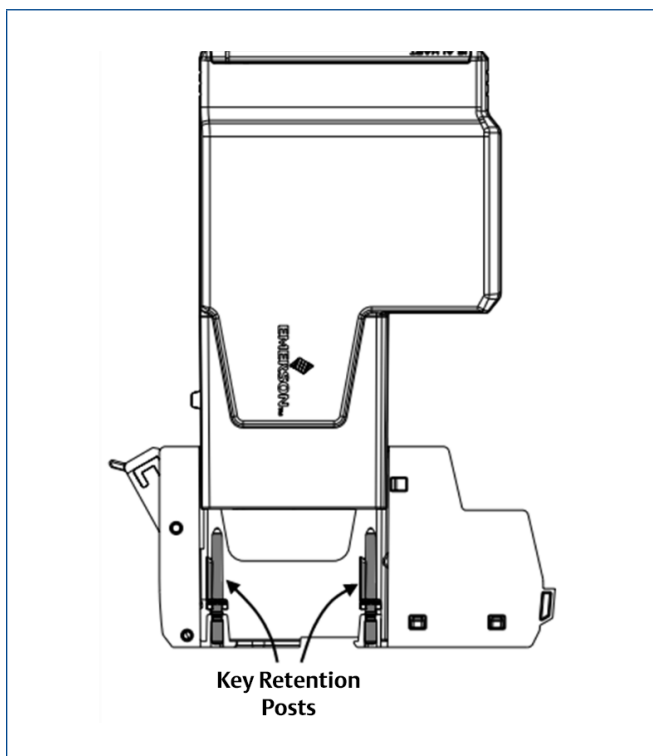

IS CHARM Standard Terminal Block.

The IS Terminal block has four terminals, supporting the traditional discrete and analog two- and four-wire sensor field instrumentation signals as well two-, three-, and four-wire RTD Sensors.

The IS Thermocouple / mV Terminal Block is specially designed for the usage with the LS IS Thermocouple / mV CHARM. The IS Thermocouple / mV Terminal Block and LS IS Thermocouple / mV CHARM can only be ordered as an assembly.

LS IS CHARM Keying Posts

The IS Terminal Blocks contain keying posts that are *automatically* set and locked to the unique position of the installed LS IS CHARM. The keys prevent the insertion of an incorrect LS IS CHARM during maintenance activities. The IS Terminal Blocks are shipped with the keys in a neutral position and are set when an LS IS CHARM is inserted. If needed, the keys can be manually reset to allow a channel to be re-tasked for a different signal type.

The keying mechanism consists of two keying posts that rotate and lock into the IS terminal block base. Each LS IS CHARM type is assigned a unique key setting.

IS CHARM Baseplates

IS CHARM baseplates are mechanically different than non-IS baseplates, ensuring there is no error in the installation of the Terminal Blocks or CHARMs (non-IS). A baseplate separator is needed on the beginning and on the end of any IS CHARM baseplate row, also in between any of the IS CHARM baseplates. You can add IS CHARM baseplates to non-IS CHARM baseplates and any of the other components, like the CSLS carrier, CHARM baseplate extenders and CHARM baseplate terminators.

DeltaV SIS CSLS Capacities

Item	Limit
Maximum number of CSLSs on a single SZ Controller	16
Maximum number of Remote I/O Nodes (CIOCs and/or WIOCs) reporting to a single SZ Controller	4
Maximum number of secure parameters per CSLS	96
Maximum number of CSLS I/O channels on a single SZ Controller: 96 CHARMs I/O channels × 16 CSLS	1536
Maximum number of CSLSs in a single DeltaV SIS system: 100 SZ controllers × 16 CSLS per SZ controller	1600

Hardware Specifications

Common Environmental Specifications (all components)	
Operating Temperature*	-40 to 70°C (-40 to 158°F)
Storage Temperature	-40 to 85°C (-40 to 185°F)
Relative Humidity	5 to 95% , non-condensing
Protection Rating	IP 20
Airborne Contaminants	ISA-S71.04-1985 Airborne Contaminants Class G3 Conformal coating
Shock	10 g ½-sine wave for 11 ms
Vibration	1mm Peak-to-Peak from 2 to 13.2 Hz; 0.7g from 13.2 to 150 Hz

*Operating any electronics at the higher end of its temperature range for long periods of time will shorten its expected lifetime, see **Effects of Heat and Airflow Inside an Enclosure White Paper** for more information.

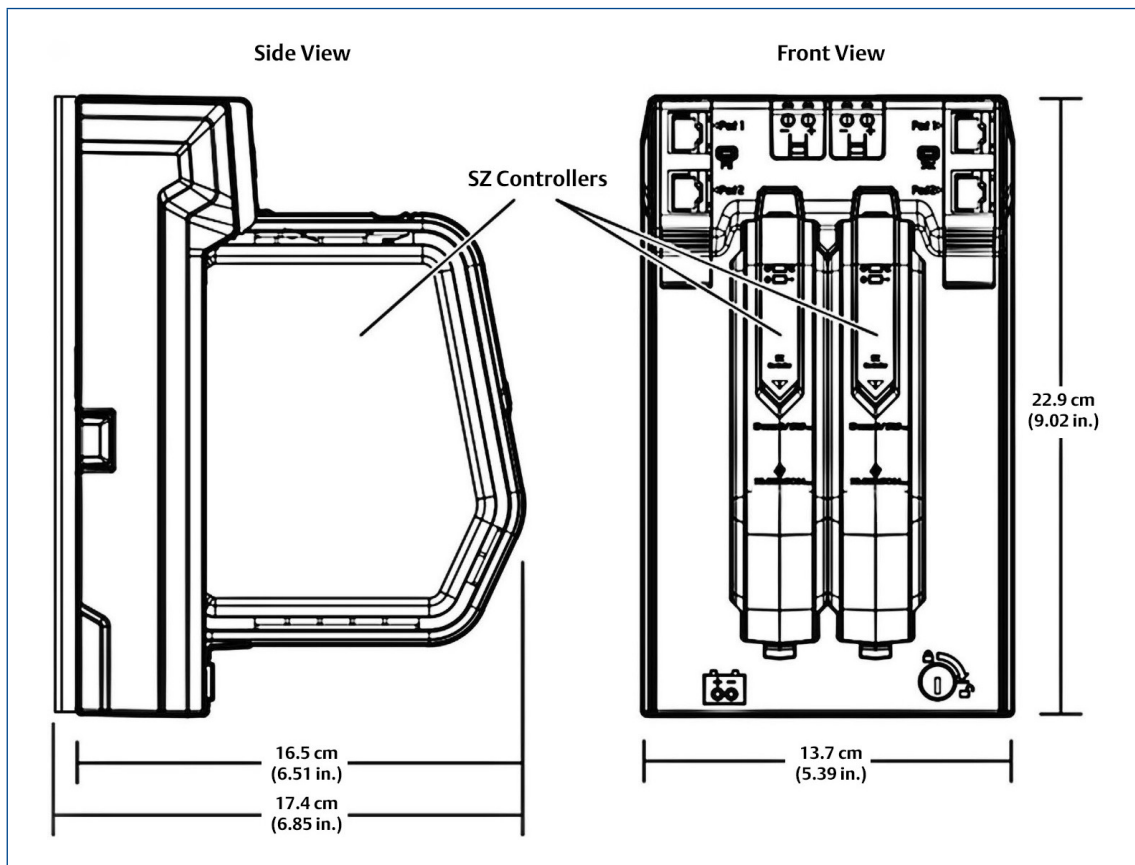

SZ Controller shown on Dual Vertical Safety Carrier.

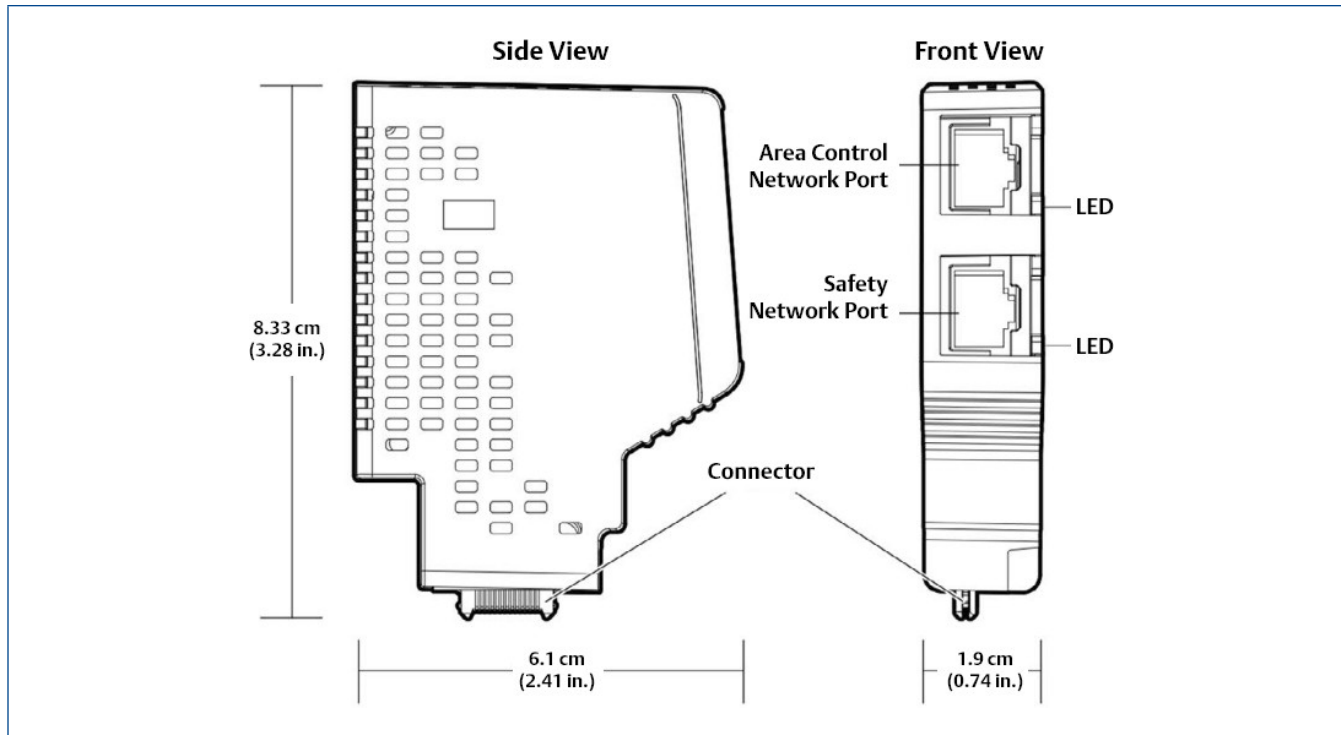

SZ Controller Ethernet Isolation Port or Keylock Ethernet Isolation Port.

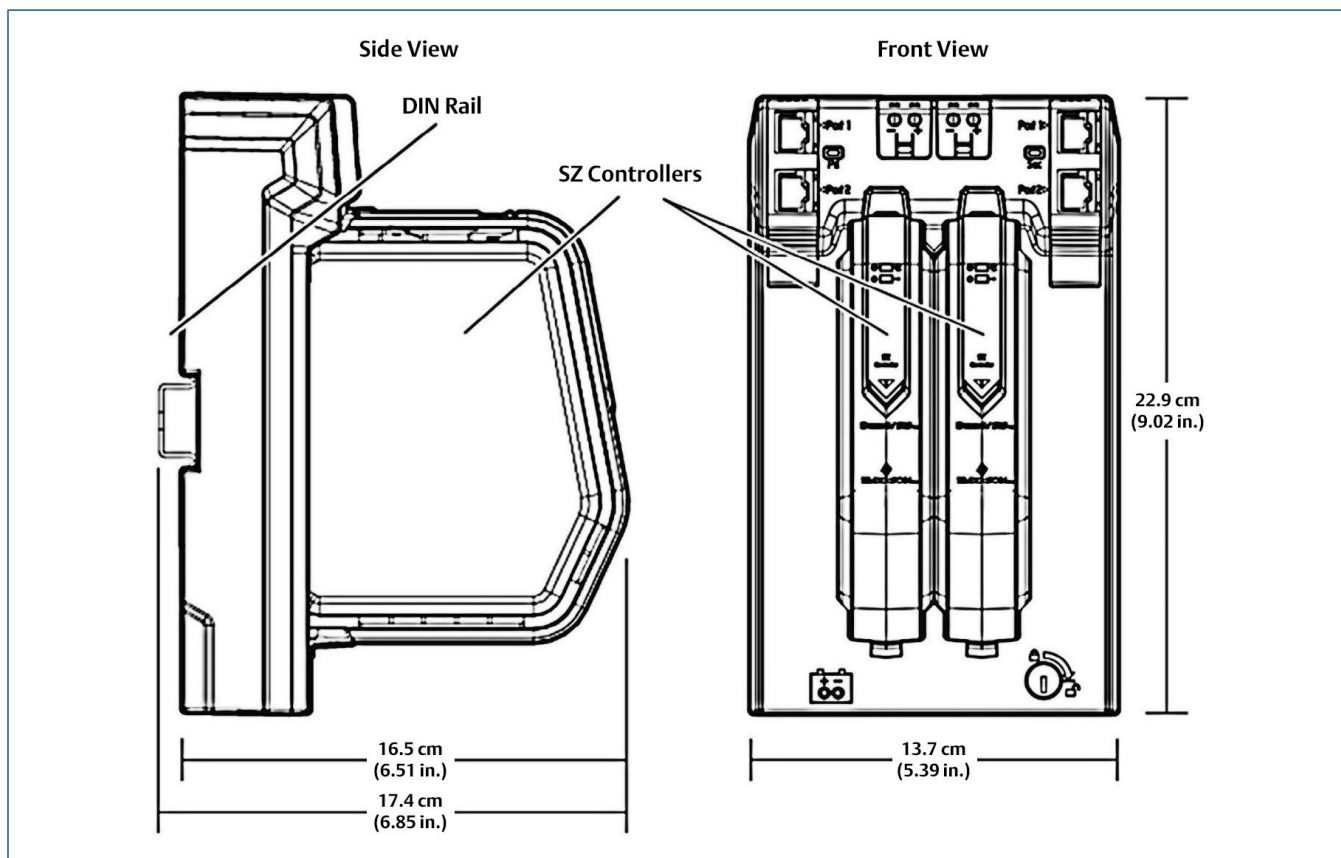

SZ Controller shown on Dual Horizontal Safety Carrier.

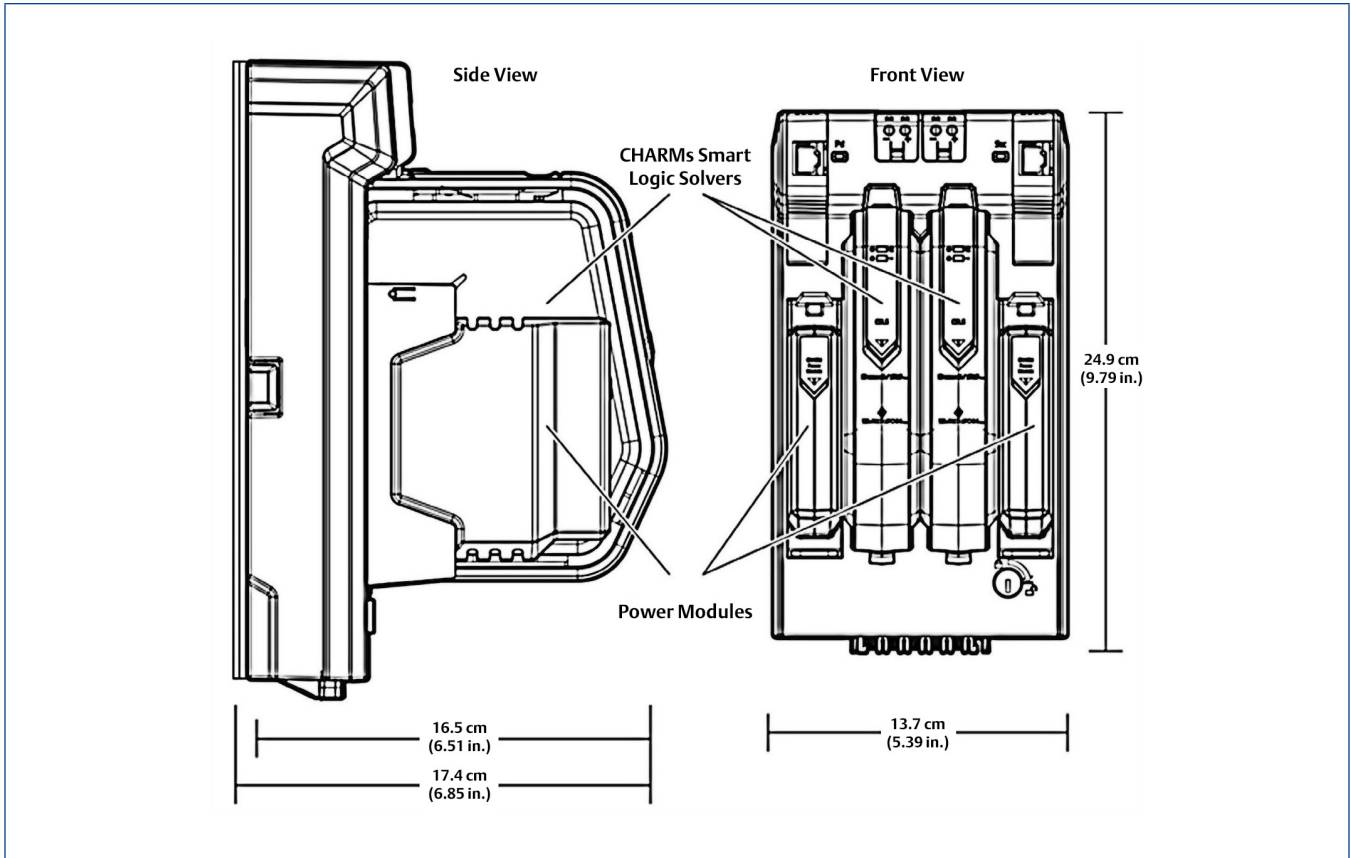

CSLS shown on CSLS Carrier.

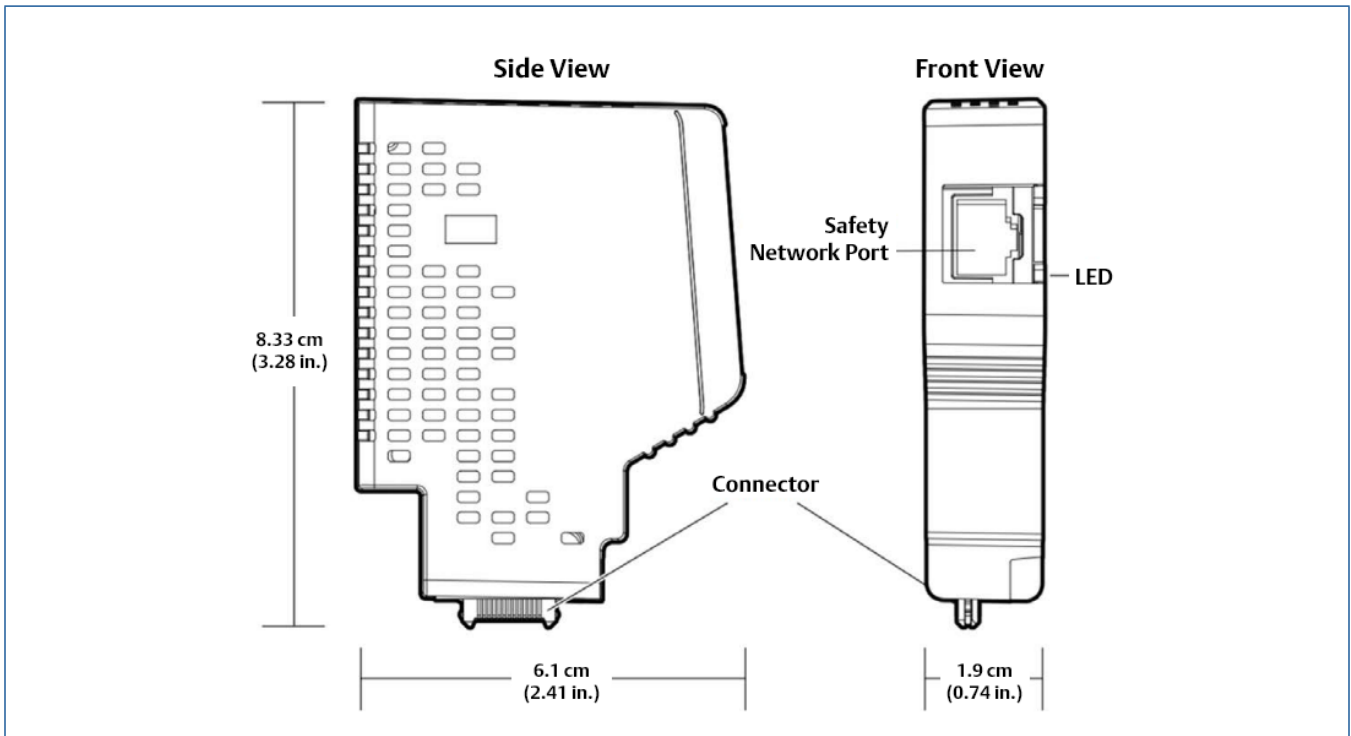

CSLS Safety Network Port.

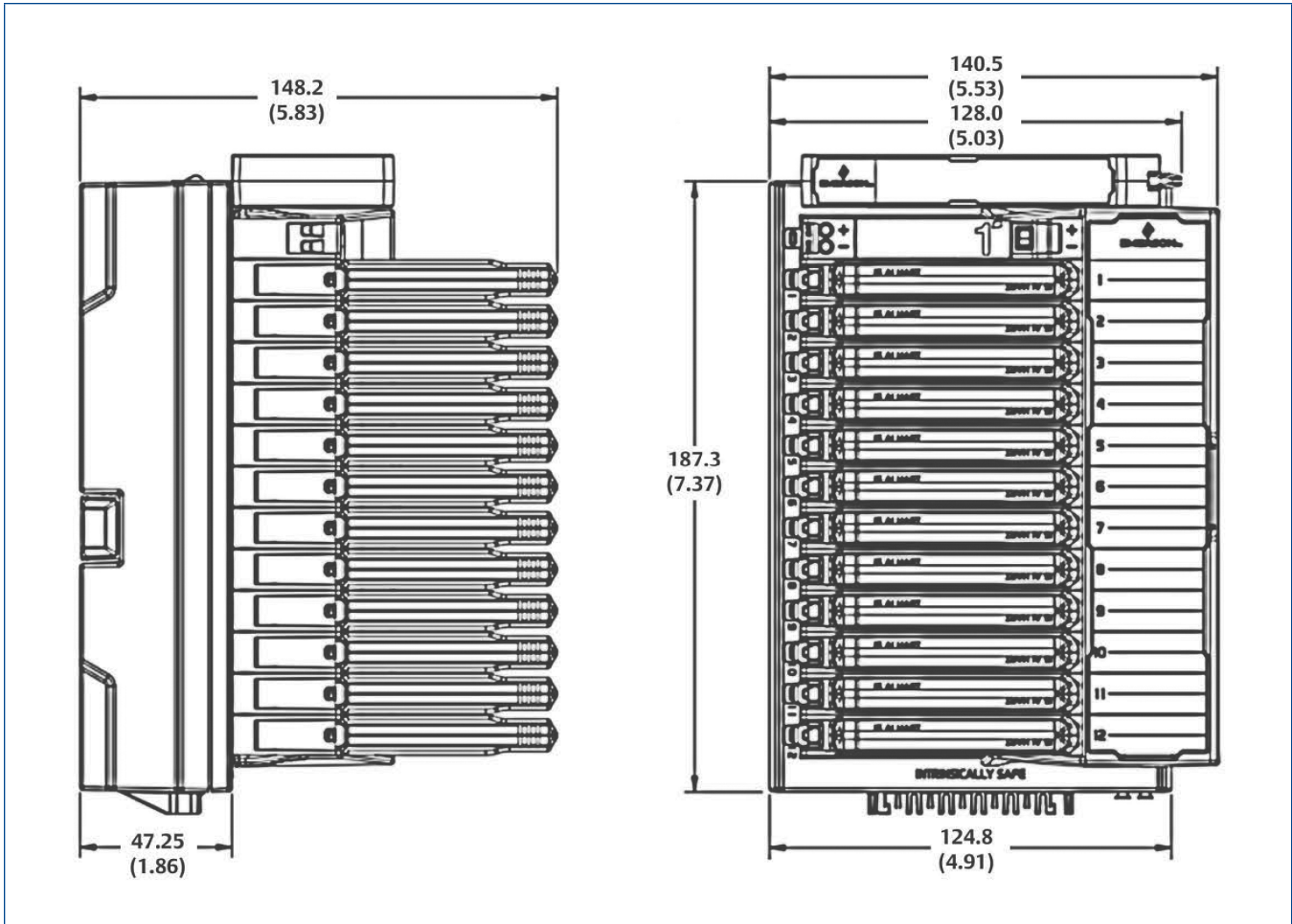

IS CHARM Baseplate with Separator, IS CHARMs and Label Plates in Place.

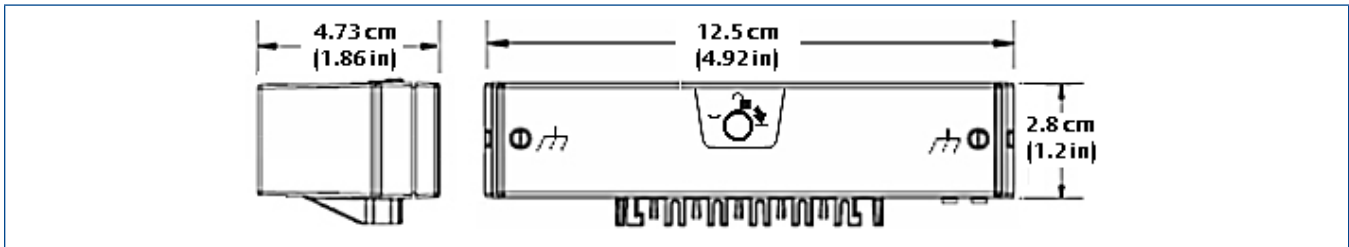

CHARM Baseplate Terminator Top.

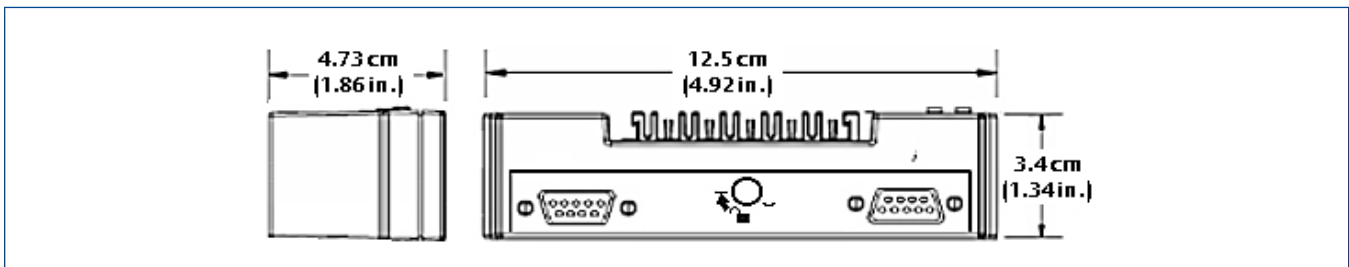

CHARM Baseplate Terminator Bottom.

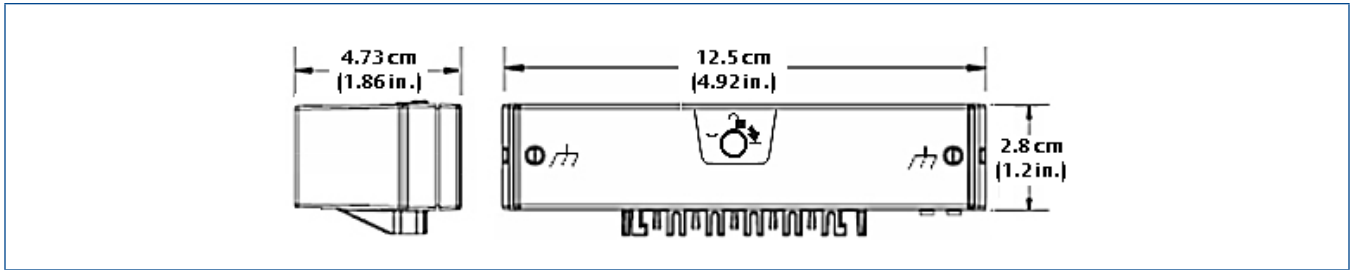

CHARM Baseplate Extender Top.

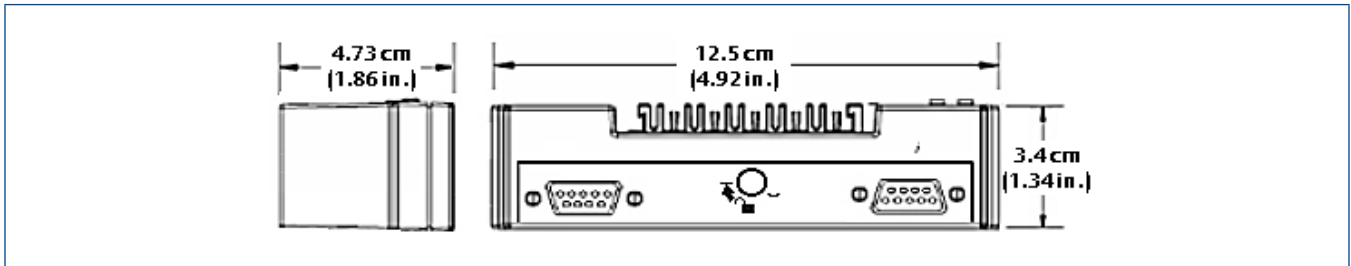

CHARM Baseplate Extender Bottom.

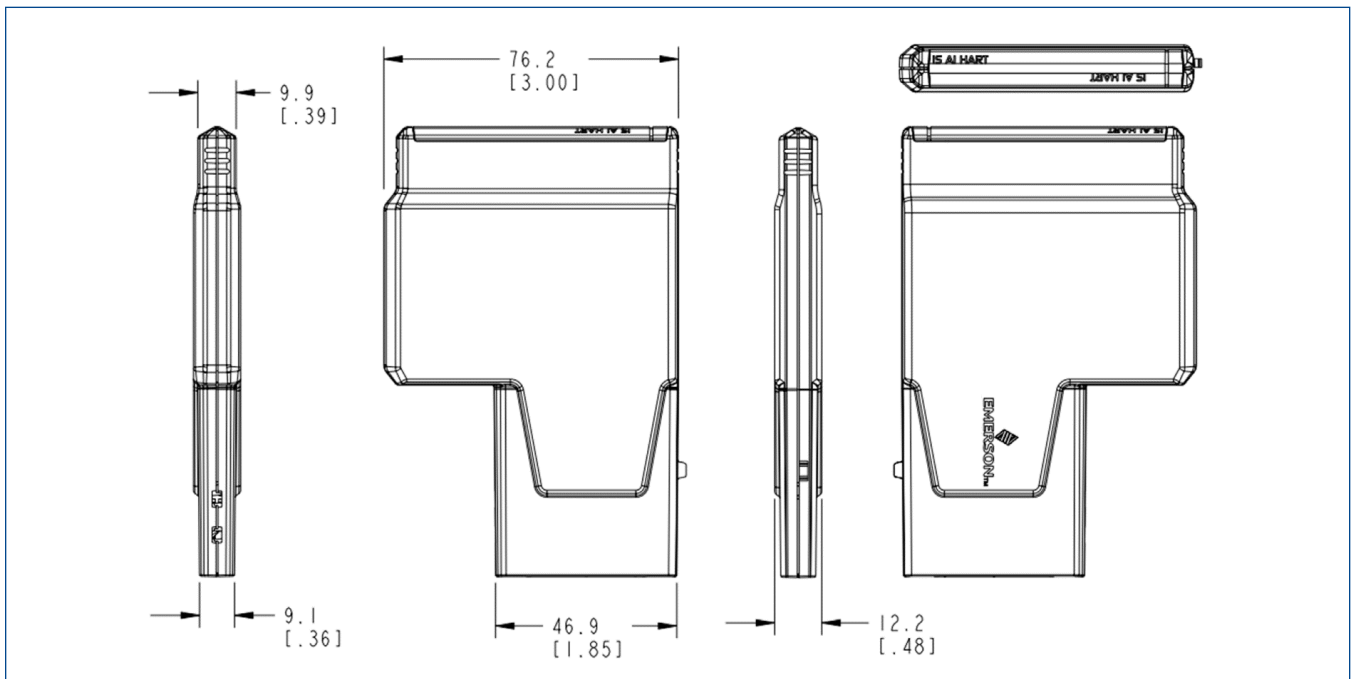

LS IS CHARM.

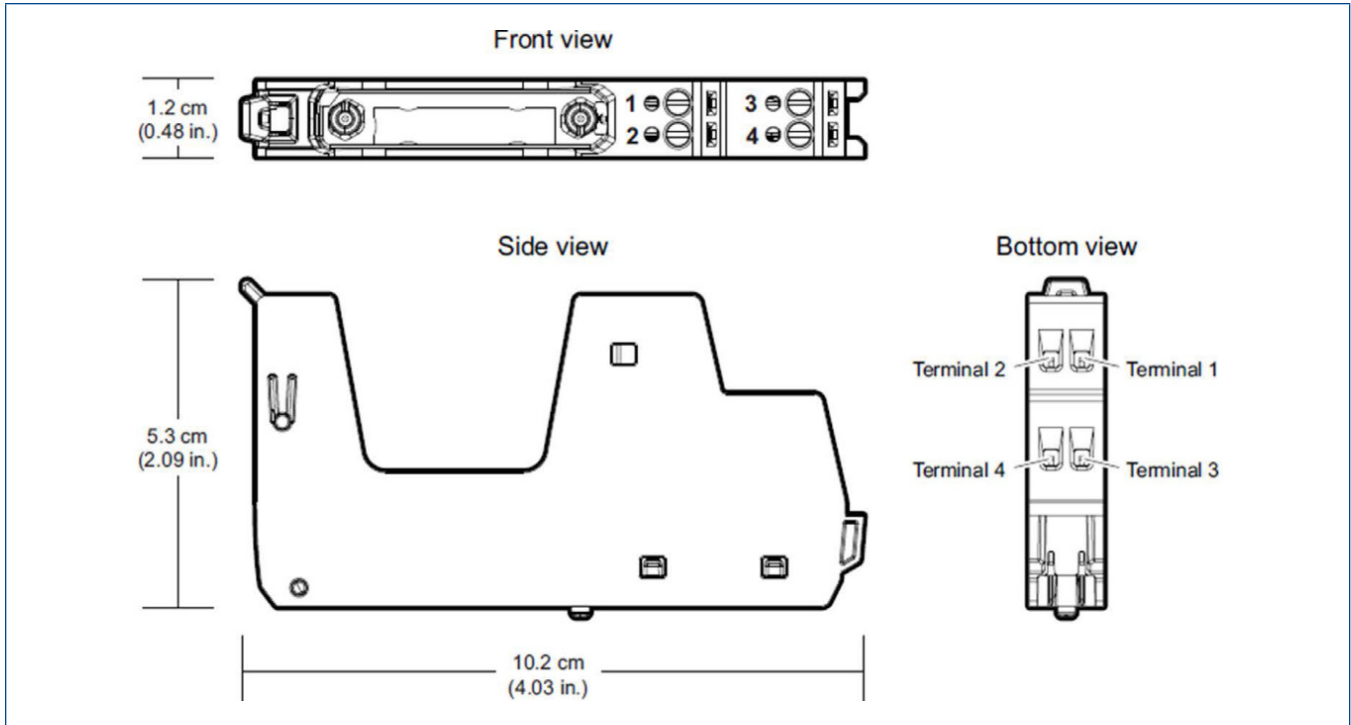

IS CHARM Terminal Block.

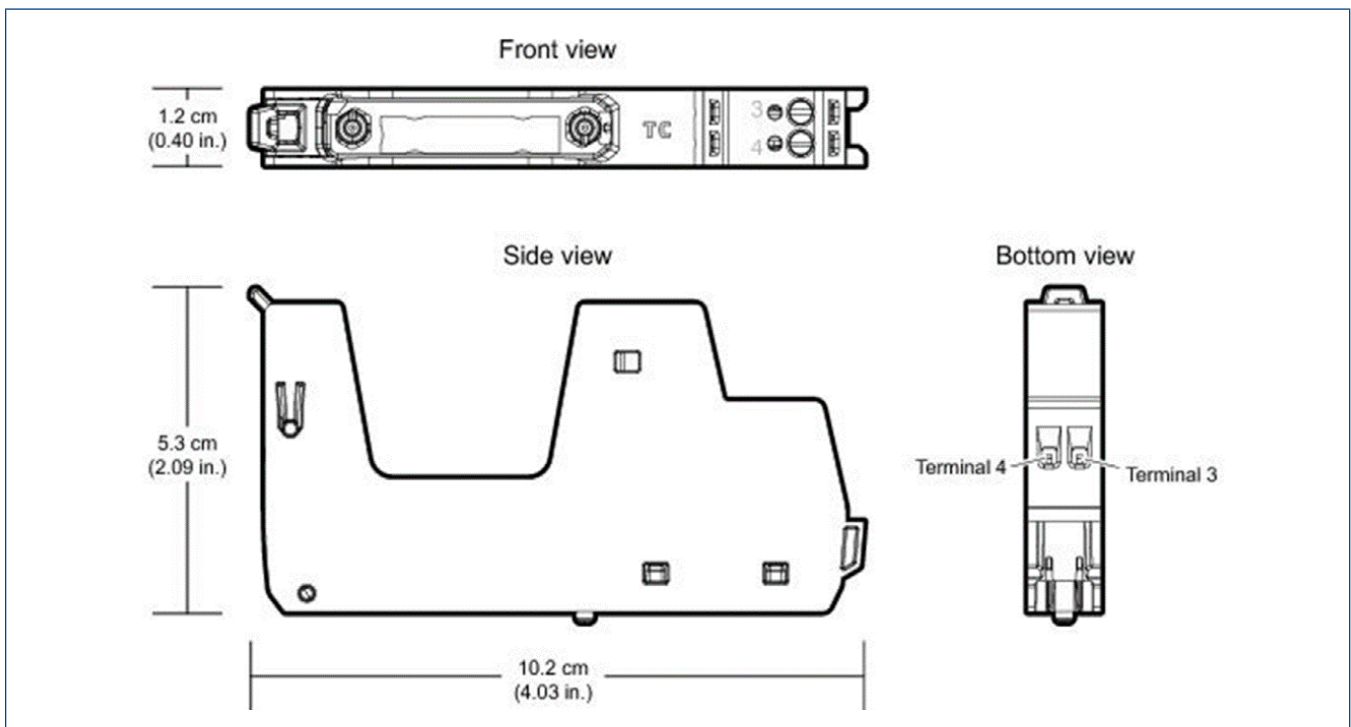

IS CHARM Thermocouple / mV Terminal Block.

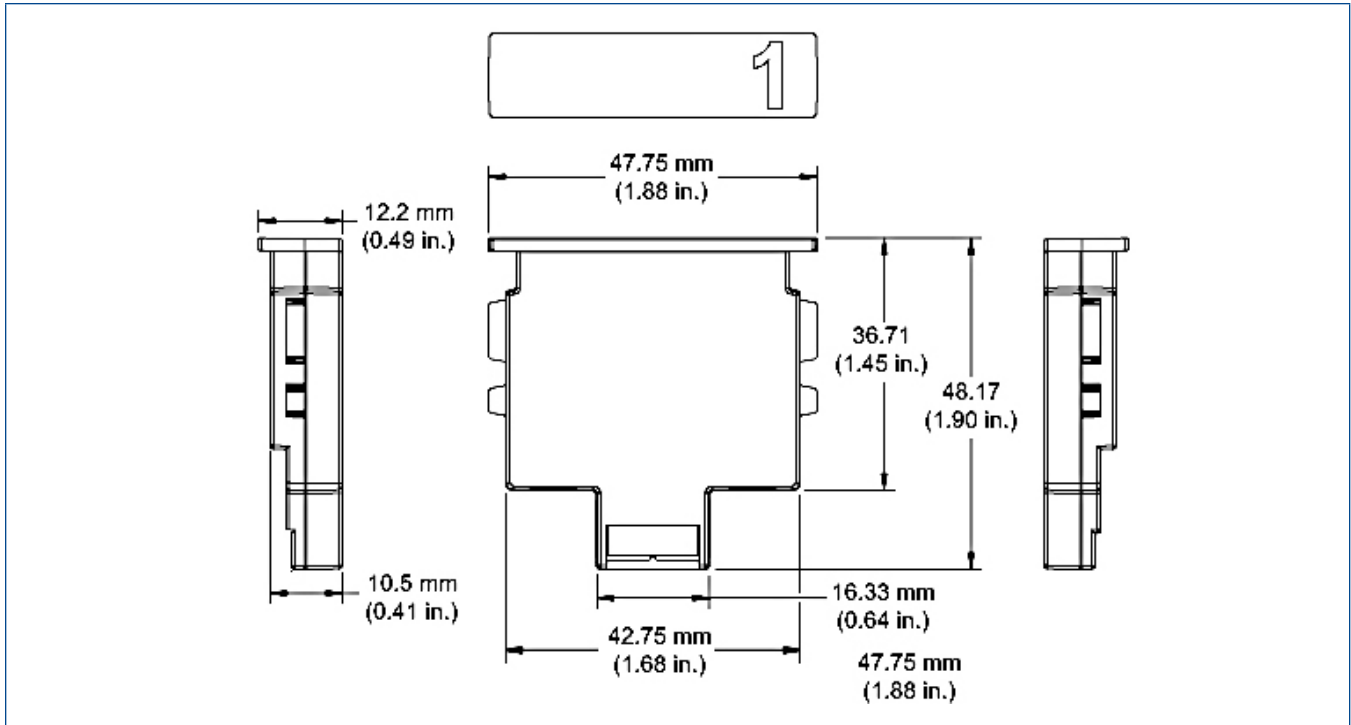

Address Plug.

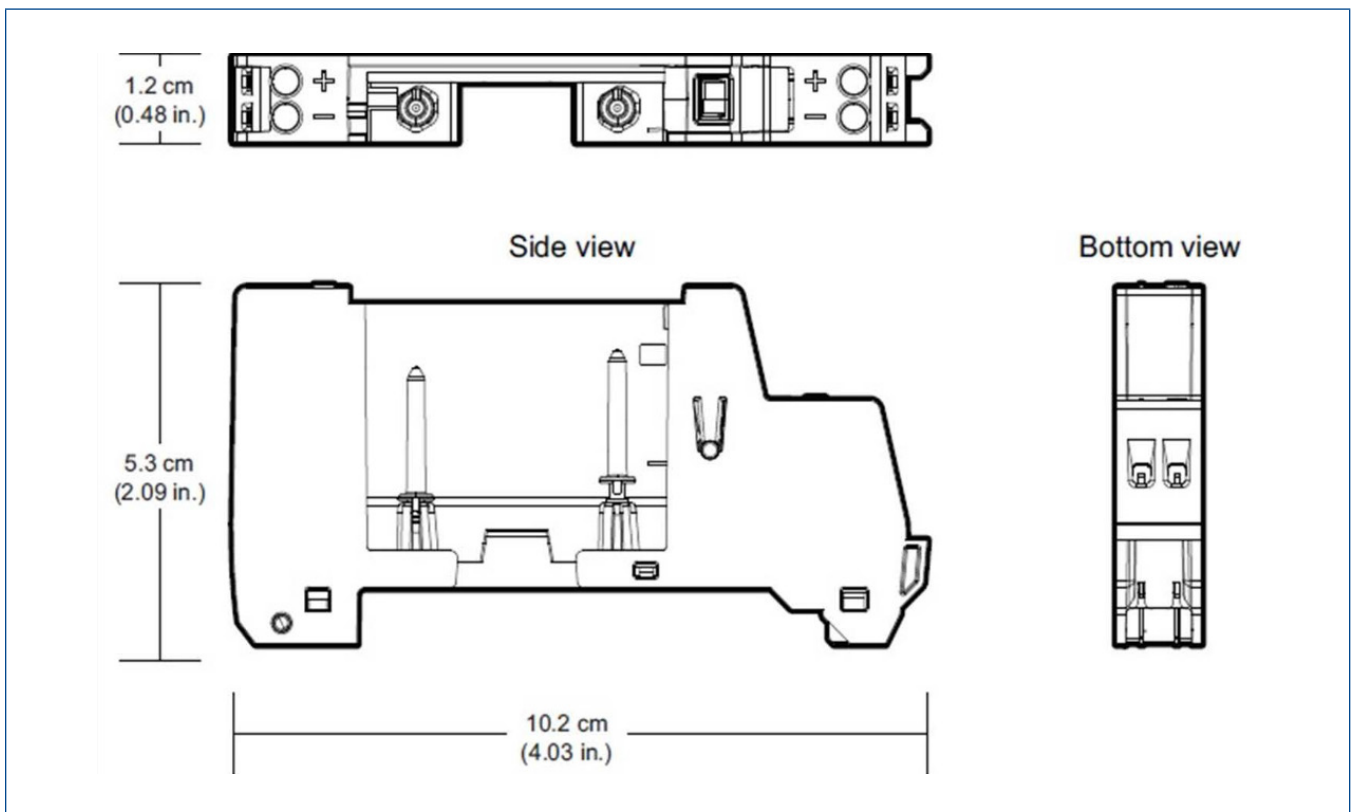

Address Plug Terminal Block for IS Baseplate.

SZ Controller Hardware

Specifications for SZ Controller and Carriers	
Capacity	One (simplex) or two (redundant) SZ Controllers
Input Power	+24V DC \pm 10% at 1 A maximum
Battery Power	+5.0 to +12.6V DC at 30 uA typical
Redundant Ethernet Connections Through Replaceable Ethernet Isolation Ports (EIPs) or Keylock Ethernet Isolation Ports	Copper twisted pair: 10/100BASE-TX with RJ45 connectors; Full duplex operation - 100 m distance
Dual Vertical Safety Carrier Mounting	DIN rail latch to vertical orientated T-type rail
Dual Horizontal Safety Carrier Mounting	DIN rail latch to horizontally orientated T-type rail
Specifications for SZ Controller	
Number of SZs per System	100
Input Power	+24V DC \pm 10% at 325 mA maximum for simplex; 575 mA maximum for redundant
Heat Dissipation (Redundant)	Seven Watts maximum for simplex; 13 Watts maximum for redundant
Fuse Protection (Internal)	Internal non-replaceable fuse
Mounting	One or two slots on the Dual Vertical or Horizontal Safety Carrier
Communication	Redundant Ethernet connections through Dual Vertical or Horizontal Safety Carrier to the: <ul style="list-style-type: none"> a) LSN b) Area Control Network (ACN) or Modbus TCP ports
Network Addressing	Auto Assigned during commissioning
Modbus TCP Addressing	Manual, Slave only
DST Limit	400
Max Data Values Sent	4000/second
Max Data Values Received	500/second
Max Unsolicited Client Nodes	120
BPCS Module Execution Rates	100ms, 200ms, 500ms, 1s, 2s, 5s, 10s, 30s, 60s
LED Indicators	
Green – Power	Indicates DC power is applied.
Red – Error	Indicates an error condition.
Green – Active/Standby	Indicates operating mode of each SZ
Yellow Flashing – Pri./Sec. CN	Indicates valid control network communication

CSLS Hardware

Specifications for CSLS Carrier	
Capacity	One (simplex) or two (redundant) CSLS and One (simplex) or two (redundant) Power Modules
Input Power (Redundant)	+24V DC \pm 10% at 12.5 A maximum
Output Power to SIS CHARMS	+24V DC \pm 10% at 10 A maximum
Redundant Ethernet Connections Through Replaceable Safety	+6.3V DC at 4 A maximum
Network Ports (SNPs)	Copper twisted pair: 10/100BASE-TX with RJ45 connectors; Full duplex operation – 100 m distance
Mounting	DIN rail latch to vertical orientated T-type rail
Specifications for CSLS and CSLS+	
Number of I/O Channels	96 Channels, Individually defined signal types
Number of CSLSs per SZ Controller	16
Number of CSLSs per System	1600
I/O Update Rates	50ms
Power Requirement of CSLS	CSLS+: +24V DC \pm 10% at 200 mA maximum for simplex; 325 mA maximum for redundant (CHARMs are additional) CSLS: +24V DC \pm 10% at 325 mA maximum for simplex; 575 mA maximum for redundant (CHARMs are additional)
Power Requirement of Power Modules	+24V DC \pm 10% at 1.5 Amps maximum simplex and redundant
Power Modules Output to LS-CHARMs	+6.3V DC \pm 3% at 4 Amps maximum
Heat Dissipation per Carrier with Redundant CSLS Pair	18 Watts maximum, which includes: <ul style="list-style-type: none"> ■ 13 Watts for redundant CSLS (7 Watts for simplex) or ■ 8.5 Watts for redundant CSLS+ (5 Watts for simplex) ■ 3 Watts for redundant Power Modules ■ 1 Watt per Safety Network Port
Fuse Protection (Internal)	Internal non-replaceable fuse
Mounting	One or two slots on the CSLS Carrier
Communication	Redundant Ethernet connections through CSLS Carrier SNPs
Network Addressing	Auto Assigned during commissioning
LED Indicators	
Green – Power	Indicates DC power is applied
Red – Error	Indicates an error condition
Green – Active/Standby	Indicates operating mode of each CSLS
Yellow Flashing – Pri./Sec. CN	Indicates valid control network communication

IS CHARMs Baseplate Hardware

Specifications for IS CHARM Baseplate	
Number of Channels per Baseplate	12
Number of Baseplates per CSLS	Eight
Addressing	One Address Plug (One through Eight)
Terminal Blocks	IS Standard Terminal Block (Light Blue) IS Thermocouple / mV Terminal Block (Light Blue)
Shield Connections	One Screw Cage terminal per channel, plus One for cable shield 0.32 – 2.5 mm ² / 22 – 14 AWG Gold-plated connectors for shield continuity
Wire Strip Length	7 – 9 mm / 0.28 – 0.36 in.
Mounting	DIN rail Latch to T-type rail
Specifications for Baseplate Termination, Top and Bottom	
Shield Connections	Two Screw Cage Terminals 0.32 – 2.5 mm ² / 22 – 14 AWG
Wire Strip Length	7 – 9 mm / 0.28 – 0.36 in.
Specifications for Baseplate Extenders, Top and Bottom	
Primary Bus Connection	Nine-pin D-shell, Primary RS-485 communications bus Primary 24V DC field power Primary CHARM power
Secondary Bus Connection	Nine-pin D-shell, Secondary RS-485 communications bus Secondary 24V DC field power Secondary CHARM power
Specifications for Extender Cables	
Maximum Bus Length	A maximum of four extender pairs can be used and only one extender pair can exceed 0.5 meters (1.64 feet).
Available Cable Lengths	2.2 m, 1.1 m, 0.5 m (88 in, 44 in, 18 in)
Specifications for IS Terminal Block	
Number of Connections	Four Screw Cage terminals 0.32 – 2.5 mm ² / 22 – 14 AWG
Strip Length	7 – 9 mm / 0.28 – 0.36 in.
Maximum Current	45 mA at 28V DC max.*
Color	Light Blue
Specifications for IS Thermocouple / mV Terminal Block	
Number of Connections	Two Screw Cage terminals 0.32 – 2.5 mm ² / 22 – 14 AWG
Strip Length	7 – 9 mm / 0.28 – 0.36 in.
Color	Light Blue

Specifications for Address Plug Terminal Block	
Number of Connections	none
Color	Black

*Actual Current draw is determined by type of CHARM and associated field devices.

LS IS Analog Input CHARM

Specifications for LS IS AI 4-20 mA HART CHARM	
Sensor Types	4-20 mA with or without HART Supports two-wire and four-wire device types
Nominal Signal Range (Span)	4-20 mA, (0-20 mA optional)
Full Signal Range	0 to 22 mA
Input Impedance	360 Ω
Field Power (2-wire)	16.0 V(min) at 20 mA
Accuracy Over Temperature Range	0.1% of span (0-60°C) 0.25% of span (over -40 -70°C)
Repeatability	0.05% of span
Resolution	16 bit A/D converter
Calibration	None required
DC/50/60 Hz Common Mode Rejection	N/A
Isolation	Galvanically isolated according to EN 60079-11. Voltage peak value 375V DC.
CHARM Power Req.	60 mA max @ 24V DC \pm 10%
CHARM Heat Dissipation	0.86 W
HART Support	HART v7 pass-through for AMS HART v7 variable and device status available to control
HART Data Update Rates	Typically less than one second but dependent on HART communication loading and the capability of the HART device

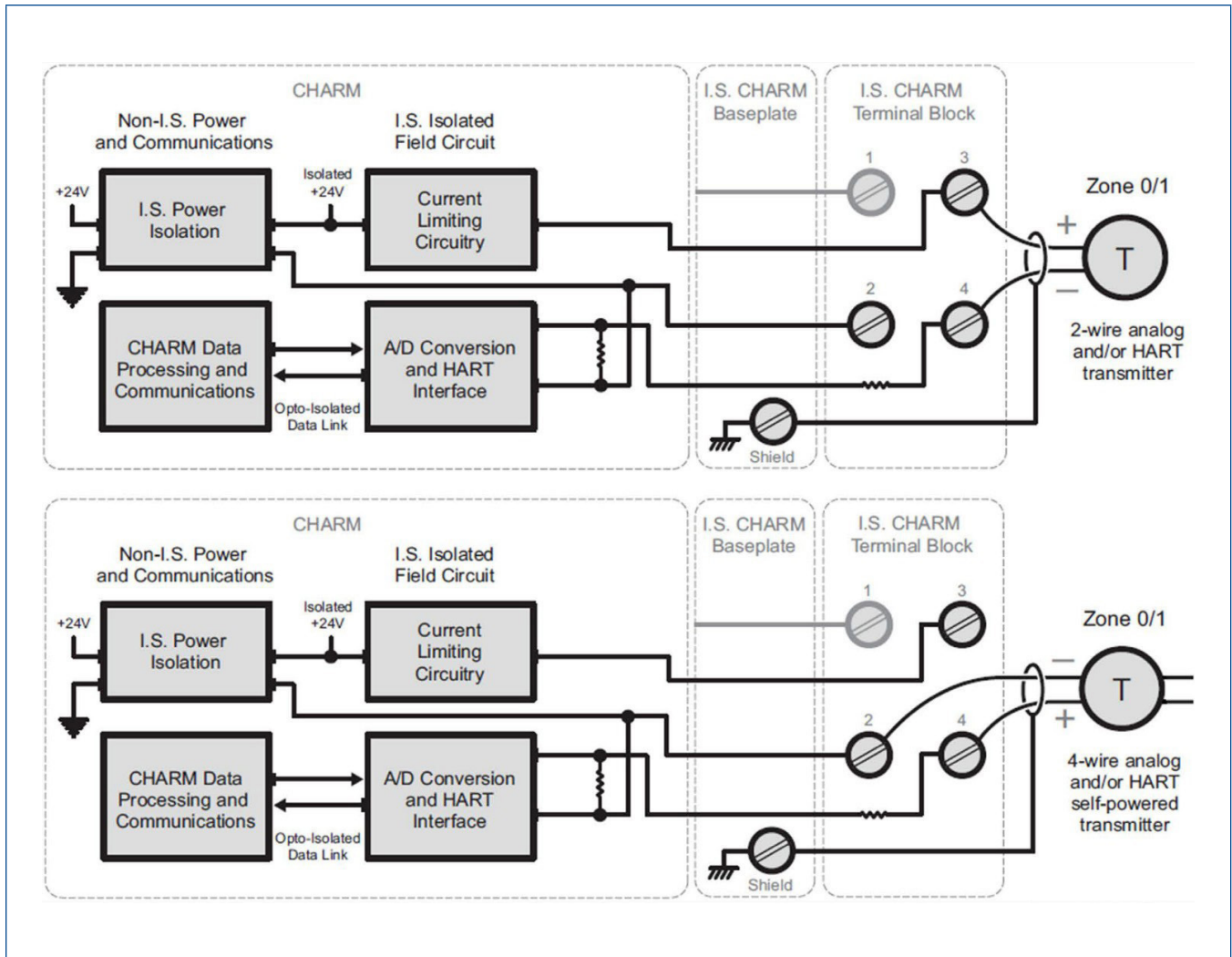

Simplified Circuit and Connection Diagrams for LS IS AI-CHARM 4 to 20 mA HART Two-Wire and Four-Wire transmitters.

LS IS RTD CHARM

Specifications for LS IS RTD Input CHARM	
Sensor Types	RTD input (Types listed in Table)
Sensor Configuration	Two-Wire, three-wire, or four-wire
Full Scale Signal Range	See Table next page
Accuracy	See Table next page
Repeatability	0.05% of span
Resolution	24 bit A/D converter / Depends upon the sensor type
Calibration	None required
Sensor Excitation Current	0.5 mA in Two-Wire and four-wire configurations 0.25 mA in 3-wire
DC/50/60 Hz Common Mode Rejection	90dB typical
Isolation	Galvanically isolated according to EN 60079-11 Voltage peak value 375V DC.
Open Sensor Detection	Yes
CHARM Power Req.	23 mA max @ 24V DC
CHARM Heat Dissipation	0.60 W

RTD, ohms Sensor Type Specifications				
Sensor Type	Operating Range	25° Reference Accuracy (4-wire)	Temperature Drift (4-wire)	Resolution
Pt100	-200 to 850°C	± 0.50°C	± 0.015°C/°C	~0.02° C
Pt200	-200 to 850°C	± 0.40°C	± 0.014°C/°C	~0.02° C
Pt500	-200 to 850°C	± 0.34°C	± 0.014°C/°C	~0.02° C
Pt1000	-200 to 260°C	± 0.14°C	± 0.006°C/°C	~0.01° C
Ni120	-80 to 260°C	± 0.18°C	± 0.003°C/°C	~0.01° C
Ni100	-80 to 260°C	± 0.12°C	± 0.003°C/°C	~0.01° C
Ni200	-80 to 260°C	± 0.11°C	± 0.003°C/°C	~0.01° C
Ni500	-80 to 260°C	± 0.08°C	± 0.003°C/°C	~0.01° C
Ni1000	-80 to 140°C	± 0.06°C	± 0.003°C/°C	~0.01° C
Cu10	-200 to 260°C	± 0.70°C	± 0.020°C/°C	~0.01° C
Resistance/ User Defined*	0 to 2,000 Ω	± 0.50 Ω	± 0.020 Ω/°C	~0.031 Ω

*The Callendar-Van Dusen linearization equation can be used with user defined Pt RTDs. Refer to Recommended I/O Practices in DeltaV Books online for usage information.

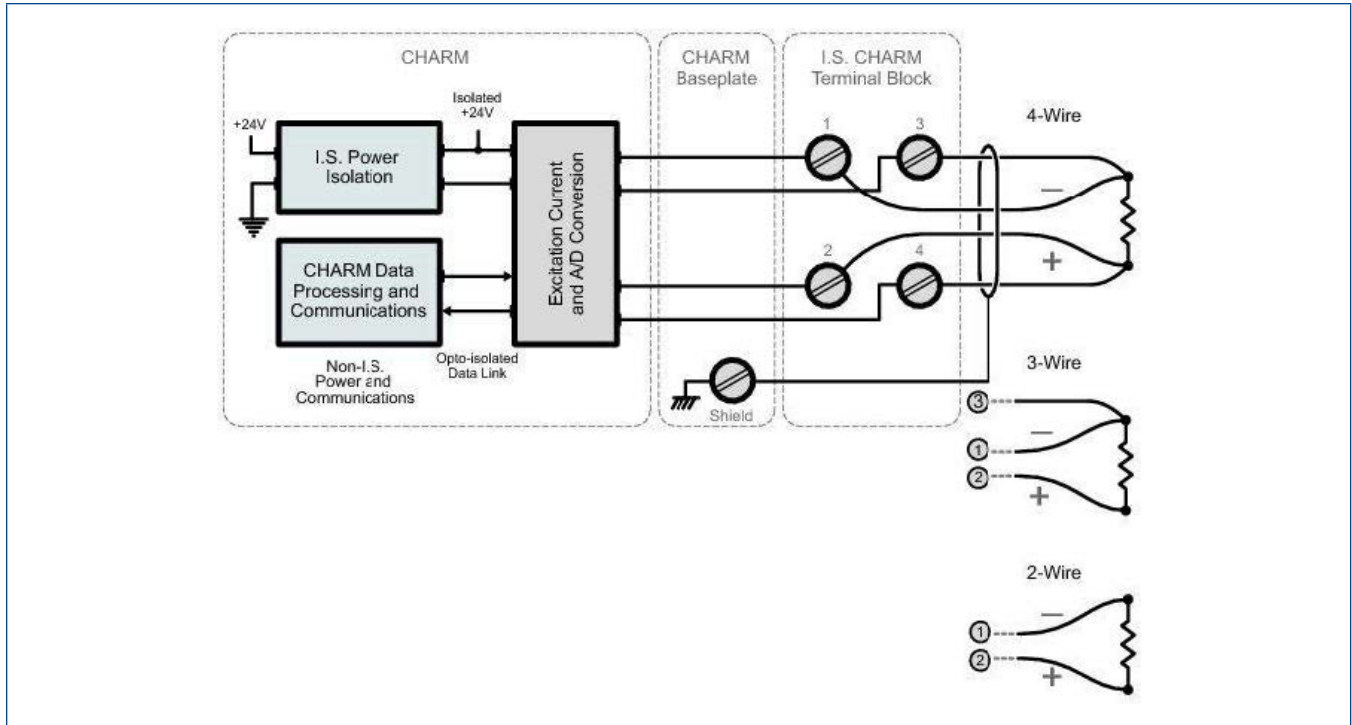

Simplified Circuit and Connection Diagrams for LS IS RTD CHARM.

LS IS Thermocouple / mV CHARM

Specifications for LS IS Thermocouple/mV Input CHARM	
Sensor Types	B, E, J, K, N, R, S, T, uncharacterized Low level voltage source (± 20 mV, ± 50 mV, and ± 100 mV)
<ul style="list-style-type: none"> ■ Thermocouple ■ mV 	
Full Scale Signal Range	See Table next page
Accuracy	See Table next page
Repeatability	0.05% of span
Resolution	24 Bit A/D converter / Depends upon the sensor type
Calibration	None required
Cold Junction Compensation (CJC) Accuracy Range	$\pm 0.7^{\circ}\text{C}$ -40 to 85°C
Temperature Drift	$0.03^{\circ}\text{C}/^{\circ}\text{C}$
Isolation	Galvanically isolated according to EN 60079-11. Voltage peak value 375V DC.
Open Sensor Detection	Yes
CHARM Power Req.	23 mA max @ 24V DC
CHARM Heat Dissipation	0.60 W

Sensor Type Specifications					
Sensor Type	25° Reference Accuracy ¹	Temperature Drift	Nominal Resolution	Full Scale	Operating Range
B	± 2.50°C ± 1.70°C	± 0.07°C/°C ± 0.05°C/°C	~0.024°C	0 to 1820°C	250 to 400°C 400 to 1820°C
E	± 0.60°C	± 0.03°C/°C	~0.018°C	-270 to 1000°C	-200 to 1000°C
J	± 0.70°C	± 0.03°C/°C	~0.022°C	-210 to 1200°C	-200 to 1200°C
K	± 1.20°C	± 0.05°C/°C	~0.025°C	-270 to 1372°C	-200 to 1370°C
N	± 1.10°C	± 0.04°C/°C	~0.024°C	-270 to 1300°C	-200 to 1300°C
R	± 1.70°C	± 0.06°C/°C	~0.028°C	-50 to 1768°C	-50 to 1767°C
S	± 1.90°C	± 0.07°C/°C	~0.028°C	-50 to 1768°C	-50 to 1767°C
T	± 0.70°C	± 0.02°C/°C	~0.01°C	-270 to 400°C	-200 to 400°C
± 100 mV	50 µV	± 2.5 µV/°C	~0.0031mV	-100 to 100 mV	-100 to 100 mV
± 50 mV	40 µV	± 1.7 µV/°C	~0.0015mV	-50 to 50 mV	-50 to 50 mV
± 20 mV	20 µV	± 0.8 µV/°C	~0.0006mV	-20 to 20 mV	-20 to 20 mV

¹Total error is made up of the 25°C reference accuracy value, plus the CIC accuracy value, plus the sensor accuracy value

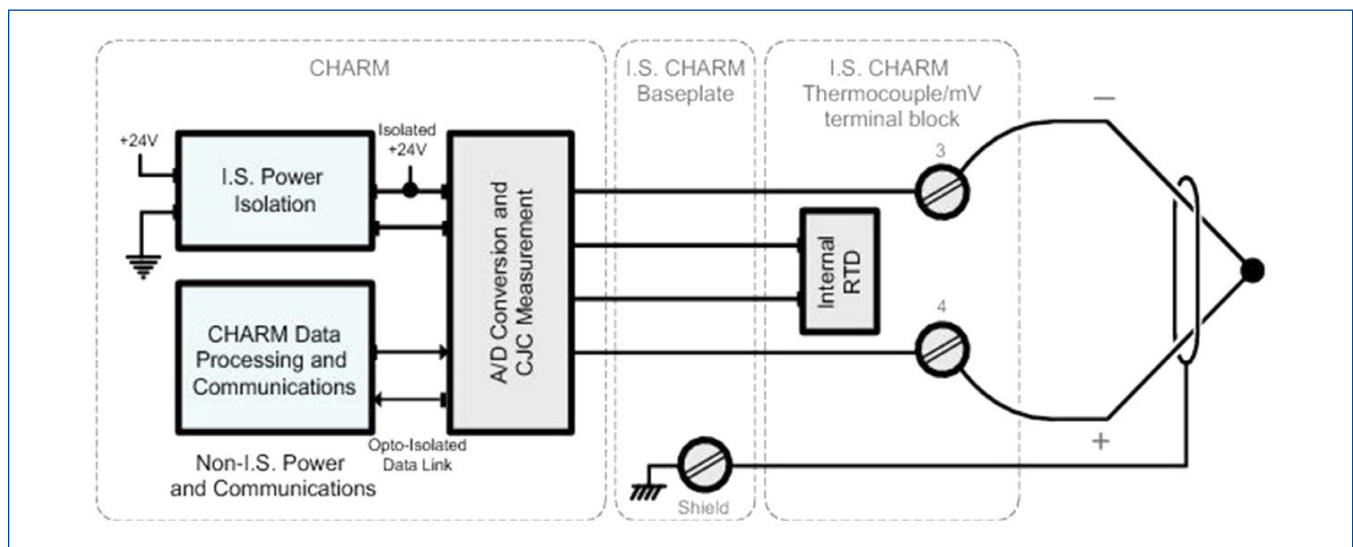

Simplified Circuit and Connection Diagram for LS IS Thermocouple/mV CHARM with IS Thermocouple/mV Terminal Block.

LS IS Discrete Input CHARM

Specifications for LS IS DI NAMUR CHARM	
Sensor Types	NAMUR Sensors, Dry Contacts
Detection Level for On	2.1 mA
Detection Level for Off	< 1.2 mA
Channel Impedance	1kOhm ± 10%
Wetting Voltage	8V DC ± 1V DC
Fault detection capable with NAMUR sensor or with an optional field resistor pack* as shown on Option 2 in diagram below (Option 1 in diagram below is not fault detection capable)	<ul style="list-style-type: none"> ■ Guaranteed short circuit: <100 Ω ■ Guaranteed good status: 360 Ω to 20 kΩ ■ Guaranteed open circuit: > 75 kΩ
Configurable Channel Types: <ul style="list-style-type: none"> ■ Discrete Input 	Dry contact or discrete state sensor changing <2 Hz
Isolation	Galvanically isolated according to EN 60079-11. Voltage peak value 375V DC.
CHARM Power Req.	28 mA max @ 24V DC ±10%
CHARM Heat Dissipation	0.57 W

*VS6904 End of Line Resistance Module can be used for option 2, see **DeltaV SIS Conditioning Components PDS** for more info.

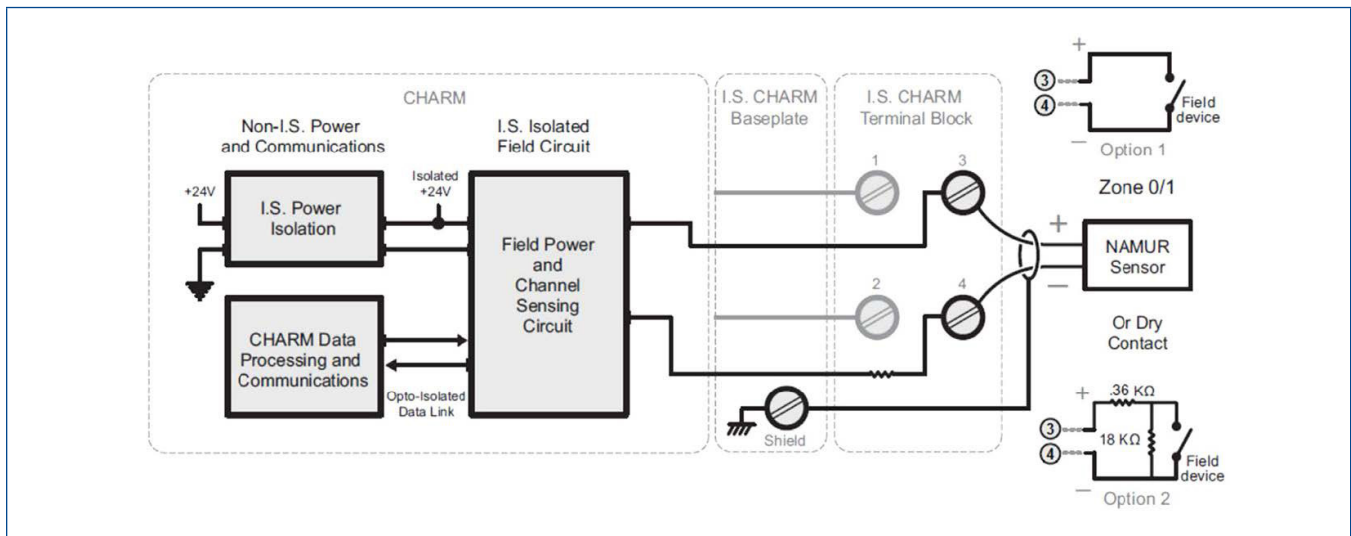

Simplified Circuit and Connection Diagram for LS IS DI NAMUR CHARM.

System Compatibility

DeltaV SIS with IS Electronic Marshalling hardware requires: DeltaV v12.3 or later software.

SZ Controllers with DeltaV v12.3 or later software.

- **CSLS (CSLS):** LS IS CHARMS installed on IS CHARM baseplates can be connected to a CSLS carrier, using a baseplate separator and a special fuse in each of the two power supply lines of the CSLS carrier.
- **Non-IS CHARM Baseplates:** Non-IS CHARM baseplates can be extended with IS CHARM baseplates, using a baseplate separator.
- **IS CHARM Baseplates:** IS CHARM baseplates cannot be extended with non-IS CHARM Baseplates.
- **Baseplate Extender:** IS CHARM baseplates can be connected to CHARM baseplate extenders using baseplate separators.
- **Baseplate Terminator:** IS CHARM baseplates can be connected to CHARM baseplate terminators using baseplate separators.
- **DeltaV SIS Smart Switches:** Refer to installation instructions for rules governing IS wiring.

Certifications

The following certifications are available on DeltaV SIS with IS Electronic Marshalling (see actual certificates for exact certifications for each product):

- **CE**
EMC- EN 61326-1
- **FM**
FM 3600
FM 3610
FM 3611
ANSI/ISA 60079-0
ANSI/ISA 60079-7
ANSI/ISA 60079-11

- **CSA**
CSA C22.2 No. 213
CSA C22.2 No. 61010-1
CSA C22.2 No. 60079-0
CSA C22.2 No. 60079-7
CSA C22.2 No. 60079-11
- **ATEX**
EN60079-0
EN60079-7
EN60079-11
- **IEC-Ex**
IEC60079-0
IEC60079-7
IEC60079-11
- **Marine Certifications:** IACS E10
DNV Marine Certificate
- **Wurldtech:** SZ Controller
Achilles Communications Certification Level 2

Hazardous Area/Location

DeltaV SIS with IS Electronic Marshalling can be installed and used based on the following Standards (see actual certificates for exact product markings for each product):

■ FM (USA)

Installation:

Class I, Division 2, Groups A, B, C, D, T4

Class I, Zone 2 AEx ec IIC T4 Gc

Field Circuits:

Class I, II, III, Division 1, Group A-G, T4

Class I, Zone 2:

AEx ec [ja Ga] IIC T4 Gc

AEx ec [ja IIIC Da] IIC T4 Gc

■ cFM (Canada)

Installation:

Class I, Division 2, Groups A, B, C, D, T4

Class I, Zone 2 Ex ec IIC T4 Gc

Field Circuits:

Class I, II, III, Division 1, Group A-G, T4

Class I, Zone 2:

Ex ec [ja Ga] IIC T4 Gc

Ex ec [ja IIIC Da] IIC T4 Gc

■ ATEX

II 3(1) G Ex ec [ja Ga] IIC T4 Gc

II 3 G (1D) Ex ec [ja IIIC Da] IIC Gc

■ IEC-Ex

II 3(1) G Ex ec [ja Ga] IIC T4 Gc

II 3 G (1D) Ex ec [ja IIIC Da] IIC Gc

Regarding the Installation instructions please refer to the following Documents:

ATEX/IECEx Installation Instructions IS-CHARM Subsystem	12P6523
Control Drawing DeltaV IS-CHARMs Subsystem	12P6122
Control Drawing DeltaV LS IS-CHARMs	12P6123

Ordering Information

SZ Controllers and CSLs	
Description	Model Number
Redundant SZ Controller Assembly (vertical carrier) – Includes 2 SZ Controllers, Dual Vertical Safety Carrier, 2 Ethernet Isolation Ports for twisted copper, 2 Power Plugs	SS3001
Redundant SZ Controller Assembly (horizontal carrier) – Includes 2 SZ Controllers, Dual Horizontal Safety Carrier, 2 Ethernet Isolation Ports for twisted copper, 2 Power Plugs	SS3003
Redundant SZ Controller Assembly (keylock - vertical carrier) – Includes 2 SZ Controllers, Dual Vertical Safety Carrier, 2 Keylock Ethernet Isolation Ports for twisted copper, 2 Power Plugs	SS3002
Redundant SZ Controller Assembly (keylock - horizontal carrier) – Includes 2 SZ Controllers, Dual Horizontal Safety Carrier, 2 Keylock Ethernet Isolation Ports for twisted copper, 2 Power Plugs	SS3004
Redundant CSLs+ Assembly - Copper (Includes CSLs Carrier, 2 CSLs+, 2 Power Modules, 2 single Safety Network Ports for twisted copper, 2 Power Plugs)	SS6511T01*
Redundant CSLs Assembly - Copper (Includes CSLs Carrier, Two CSLs, Two Power Modules, Two single Safety Network Ports for twisted copper, Two Power Plugs)	SS6501T01
Redundant CSLs Carrier Assembly - Copper , (Includes CSLs Carrier, Two single Safety Network Ports for twisted copper, Two Power Plugs)	SS6501T05
Redundant CSLs+ (Includes 2 CSLs+ and 2 Power Modules)	SS6512*
Redundant CSLs (Includes Two CSLs and Two Power Modules)	SS6502
CSLS IS CHARM Baseplates	
Description	Model Number
CSLS IS CHARMS Baseplate Assembly with Standard IS CHARM Terminal Blocks , includes IS CHARMS Baseplate, IS CHARM Address Terminal Block, 12 IS CHARM Standard Terminal blocks and a Baseplate Separation Wall	SS4608T01
CSLS Baseplate Address Plugs	
Description	Model Number
Addressing Plugs , includes Address Plugs One through eight	SS4602
Addressing Plugs , includes Address Plugs One through four	SS4613

*The CSLs+ is currently only supported on new installations with firmware rev. 2.

CSLS Baseplate Extenders, Terminators, & Cables	
Description	Model Number
CSLS Baseplate Terminator, Top (Male), (Includes a Baseplate Identifier and a Baseplate Separation Wall)	SS4604T03
CSLS Baseplate Terminator, Bottom (Female), (Includes a Baseplate Identifier and a Baseplate Separation Wall)	SS4604T04
CSLS Baseplate Extender with Cable Connectors, Top (Male), (Includes a Baseplate Identifier and a Baseplate Separation Wall)	SS4603T05
CSLS Baseplate Extender with Cable Connectors, Bottom (Female), (Includes a Baseplate Identifier and a Baseplate Separation Wall)	SS4603T06
CSLS Baseplate Extenders, Terminators, & Cables	
Description	Model Number
CSLS Baseplate Cables, includes two 18 in (0.5 m) cables	SS4605T02
CSLS Baseplate Cables, includes two 44 in (1.1 m) cables	SS4605T03
CSLS Baseplate Cables, includes two 88 in (2.2 m) cables	SS4605T04
CSLS Baseplate Labeling	
Description	Model Number
CSLS Baseplate Identifiers, Package of nine	SS4606T03
CSLS Baseplate Channel Identifier Labels, Package of eight	SS4606T02

Each vertical DIN rail requires a DIN Rail stop to lock baseplates in position. Order VE4054DRS, which is a box of 5.

LS IS CHARMS	
Description	Model Number
LS IS DI NAMUR	SS4305T01
LS IS AI 4-20 mA HART	SS4307T01
LS IS Thermocouple/mV	SS4309T01
LS IS RTD	SS4310T01

IS CHARMS and IS Terminal Block Assemblies	
Description	Model Number
LS IS Thermocouple/mV CHARM with IS Thermocouple/mV Terminal Block	SS4309T51

Additional Ordering Information for IS CHARM Protection Cover

IS CHARM Protection Cover	
Description	Model Number
IS CHARM Protection Cover; Package of 12	SS6104

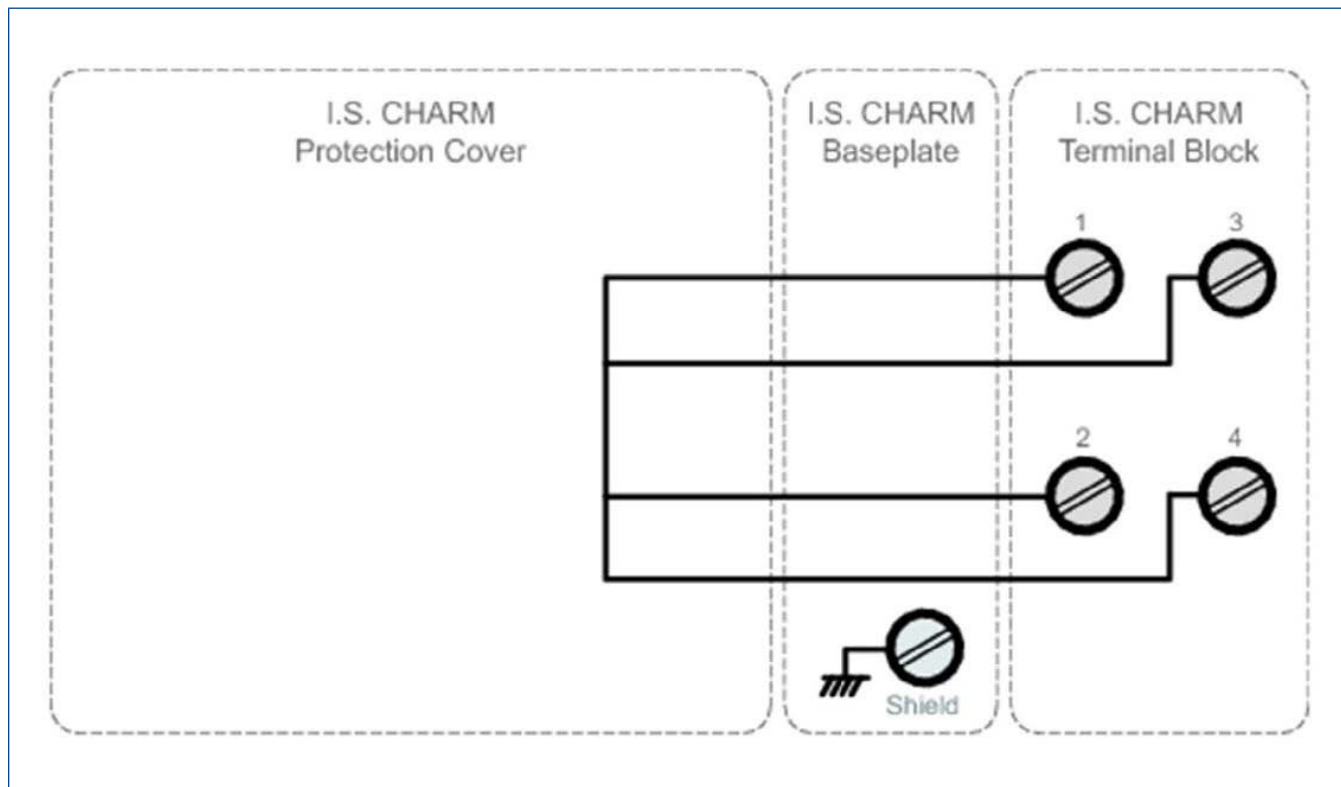

Simplified Circuit and Connection Diagram for IS CHARM Protection Cover.

When the I.S. CHARM Protection Cover is installed, all terminals on the I.S. CHARM Terminal Block are shorted! The shortened Terminals can be connected to Chassis Ground, while allowing the ground to be daisy-chained to the next I.S. CHARM Terminal block, where the next I.S. CHARM Protection Cover got installed.

Prerequisites

DeltaV SIS with IS Electronic Marshalling hardware requires DeltaV SIS v12.3. or later software.

- Only DeltaV SIS Smart Switches are supported on the LSN.
- Keylock Ethernet Isolation Port requires DeltaV SIS v14.3 or later software.

IS CHARM FUSE	
Description	Model Number
Fuse Holder and Fuse Assembly for 24V DC Power Supply of CHARM I/O CARD	SS4610T01*

*Two of these Fuse Assemblies have to be ordered with any SS6501T01 or SS6501T05, when used with IS CHARM baseplates.

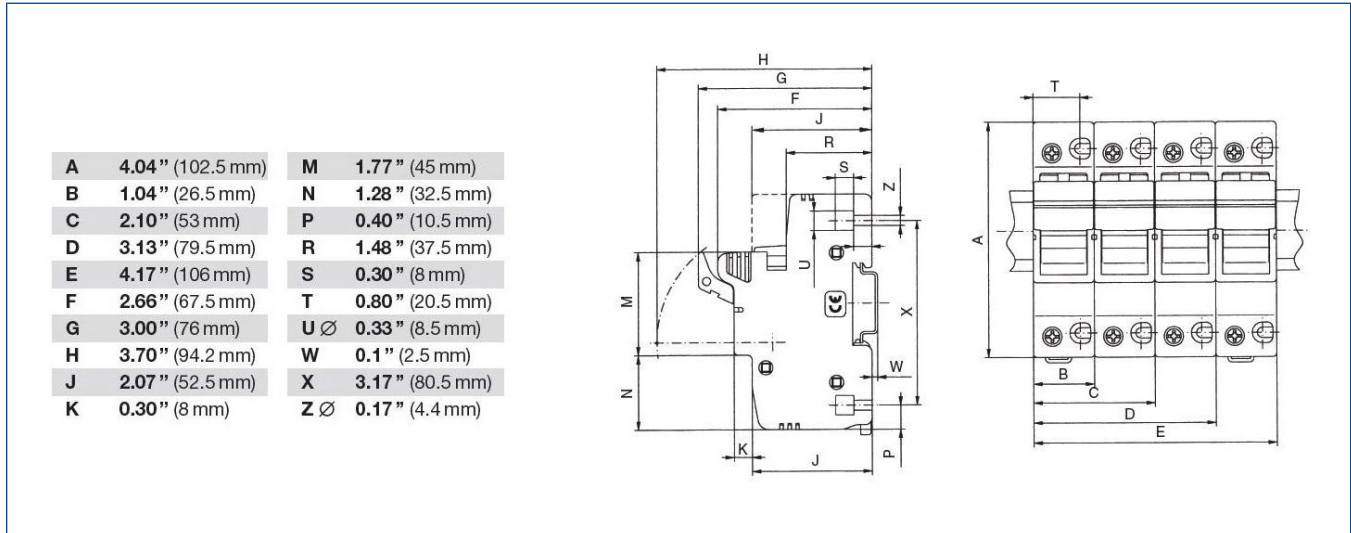

Outside Dimensions of the Fuse Hold.

SZ and CSLS Spare Part Ordering Information

SZ and CSLS Spare Parts	
Description	Model Number
Power Terminal Plug for CSLS, and Dual Vertical and Horizontal Safety Carriers	KJ4005X1-BF1
Ethernet Isolation Port; twisted copper; for Dual Vertical or Horizontal Safety Carriers	KL1604X1-BA1
Keylock Ethernet Isolation Port; twisted copper; for Dual Vertical or Horizontal Safety Carriers	KL1604X1-BB1
Power Module for CSLS Carriers	KL1501X1-BA1
Set of 2 Replacement Keys for Keylock Switch on CSLS and Dual Vertical and Horizontal Safety Carriers	SS6201

LS IS CHARM Labeling Part Ordering Information

LS IS CHARM I/O Labeling Parts	
Description	Model Number
Channel Identifier Labels for CSLS IS CHARM Baseplates; Package of eight	SS4609T01
CSLS IS Charm Baseplate Separation Wall; Package of nine	SS4609T02
Replacement Fuse for SE4610T01 Fuseholder Assembly	KL4510X1-FA1
Replacement Fuseholder for SE4610T01 Fuseholder Assembly	KL4510X1-GA1

©2025, Emerson. All rights reserved.

The Emerson logo is a trademark and service mark of Emerson Electric Co. The DeltaV logo is a mark of one of the Emerson family of companies. All other marks are the property of their respective owners.

The contents of this publication are presented for informational purposes only, and while diligent efforts were made to ensure their accuracy, they are not to be construed as warranties or guarantees, express or implied, regarding the products or services described herein or their use or applicability. All sales are governed by our terms and conditions, which are available on request. We reserve the right to modify or improve the designs or specifications of our products at any time without notice.

Contact Us

www.emerson.com/contactus