

Machinery Health™ System

A6500-UM Universal Measurement Card



Copyright

© 2024, Emerson. All rights reserved.

No part of this publication may be reproduced, transmitted, transcribed, stored in a retrieval system, or translated into any language in any form by any means without the written permission of Emerson.

Disclaimer

This manual is provided for informational purposes. EMERSON MAKES NO WARRANTY OF ANY KIND WITH REGARD TO THIS MATERIAL, INCLUDING, BUT NOT LIMITED TO, THE IMPLIED WARRANTIES OF MERCHANTABILITY AND FITNESS FOR A PARTICULAR PURPOSE. Emerson shall not be liable for errors, omissions, or inconsistencies that may be contained herein or for incidental or consequential damages in connection with the furnishing, performance, or use of this material. Information in this document is subject to change without notice and does not represent a commitment on the part of Emerson. The information in this manual is not all-inclusive and cannot cover all unique situations.

Patents

The product(s) described in this manual are covered under existing and pending patents.

-  Vermerk zur Installation der Messketten in explosionsgefährdeter Umgebung.
Soll die Messkette in explosionsgefährdeter Umgebung installiert werden, so ist auf die Einhaltung der in der Gebrauchsanweisung enthaltenen Installationshinweise zu achten. Sollten dabei sprachliche Schwierigkeiten auftreten, wenden Sie sich bitte an die Herstellerfirma, sie wird Ihnen eine Übersetzung der relevanten Artikel in der Landessprache des Verwendungslandes zukommen lassen.
-  Nota fuq l-installazzjoni tal-ktajjen tal-kejl f'ambjent esploziv
Jekk il-katina tal-kejl suppost li tigi installata f'ambjent esploziv, hu importanti li ssegwi l-istruzzjonijiet pertinenti tal-manwal. Jekk issib xi diffikultà bil-lingwa, jekk joghgbok ikkuntattja lill-manifattur biex tikseb traduzzjoni tal-paragrafi rilevanti fil-lingwa mehtiega.
-  Anmärkning beträffande installation av mätkedjorna i explosionsfarlig miljö.
Ska mätkedjan installeras i explosionsfarlig miljö, måste de anvisningar följas som ges i instruktionsboken beträffande installationen. Skulle därvid språkproblem uppstå, ber vi dig kontakta det tillverkande företaget som då kommer att sända dig en översättning av de relevanta artiklarna på användningslandets språk.
-  Opomba za namestitve merilne verige v eksplozivno ogroženem okolju
Èe se merilna veriga namešèa v eksplozivno ogroženem okolju, je potrebno upoštevati namestitvena opozorila, ki so v Navodilih za uporabo. Èe se pri tem pojavijo jezikovne težave, se posvetujte z izdelovalcem; poslali vam bodo prevod ustreznih èlankov v jeziku države, kjer se naprava uporablja.
-  Záznam k inštalácii meracích reťazcov vo výbušnom prostredí
Ak má byť merací reťazec inštalovaný vo výbušnom prostredí, treba dbať na dodržiavanie pokynov k inštalácii, uvedených v návode na použitie. V prípade, že by sa pritom vyskytli jazykové problémy, obráťte sa prosím na výrobcu, ktorý Vám zašle preklad relevantných èlánkov v jazyku Vašej krajiny.
-  Nota referente à instalação de cadeias de agrimensor em ambientes potencialmente explosivos
Caso a cadeia de agrimensor deva ser instalada em um ambiente potencialmente explosivo, é imprescindível observar e cumprir as indicações de instalação das instruções de serviço. Caso tenha dificuldades idiomáticas, queira entrar em contato com a firma produtora, esta poderá enviar-lhe uma tradução dos capítulos mais importantes no idioma do país onde o produto deverá ser empregado.
-  Wskazówka dotycząca instalacji łańcuchów mierniczych w otoczeniach zagrożonych eksplozją.
Jeżeli łańcuch mierniczy ma być zainstalowany w otoczeniu zagrożonym eksplozją, należy uwzględnić wskazówki dotyczące instalacji, które są zawarte w instrukcji obsługi. Jeżeli w trakcie lektury wystąpią jakiegokolwiek problemy związane ze zrozumieniem tekstu, prosimy zwrócić się do producenta, który chętnie wykona tłumaczenie wybranych części dokumentacji na język danego kraju.



Opmerking m.b.t. installatie van elektrische meet circuits in explosiegevaarlijke omgeving

Dient de installatie van elektrische meet circuits in een explosiegevaarlijke omgeving te geschieden, moet men toezien dat de in de gebruikshandleiding opgenomen installatieinstructies worden nageleefd. Bij taalkundige problemen gelieve contact op te nemen met de fabrikant, deze zal u vervolgens een vertaling in de taal van het gebruiksland doen toekomen.



Pastaba dėl matavimo grandinės įrengimo sprogimo atžvilgiu pavojingoje aplinkoje

Jei matavimo grandinė turi būti įrengta sprogimo atžvilgiu pavojingoje aplinkoje, privaloma laikytis vartotojo instrukcijoje pateiktų įrengimo nurodymų. Jei kiltų sunkumų dėl kalbos, prašome kreiptis į gamintojo įmonę, kuri pateiks Jums reikiamo skyriaus vertimą į vartotojo valstybės kalbą.



Nota sull'installazione delle catene per misurazione in ambienti a rischio di esplosioni

Nel caso in cui si debbano installare le catene per misurazione in ambienti a rischio di esplosioni, è necessario attenersi alle avvertenze per l'installazione contenute nelle istruzioni d'uso. Per difficoltà di carattere linguistico, rivolgetevi alla ditta produttrice. Quest'ultima Vi farà pervenire una traduzione degli articoli rilevanti nella lingua del paese d'impiego.



Megjegyzés a mérőláncok robbanásveszélyes környezetben történő szereléséhez.

Ha a mérőláncot robbanásveszélyes környezetben kell felszerelni, akkor ügyeljen a Használati útmutatóban közölt szerelési utasítások betartására. Amennyiben nyelvi nehézségek merülnek fel, szíveskedjen a gyártó céghez fordulni, amely elküldni Önnek a felhasználó ország nyelvére lefordított, erre vonatkozó cikket.



Remarque concernant l'installation des chaînes de mesure dans un environnement présentant un risque d'explosion

Si la chaîne de mesure doit être installée dans un environnement présentant un risque d'explosion, il est impératif de veiller à respecter les consignes d'installation contenues dans les instructions de service. S'il devait ce faisant surgir des problèmes linguistiques, veuillez vous adresser à la société fabricante: elle vous fera parvenir une traduction des articles significatifs dans la langue du pays de mise en oeuvre.



Huomautus mittausketjun asentamisesta räjähdysalttiissa ympäristössä

Jos mittausketju tulee asentaa räjähdysalttiissa ympäristössä, on käyttöohjeessa annettuja asennusohjeita noudatettava. Jos käyttöohjeessa käytetty kieli aiheuttaa ongelmia, kääntykää valmistajayrityksen puoleen. Se toimittaa käyttöönnne tarvittavat artikkelit käyttömaan viralliselle kielelle käännettynä.



Juhend mõõdukettide ülespanemiseks plahvatusohtlikus piirkonnas.

Kui panna üles mõõdukettid plahvatusohtlikkus piirkonnas, nii tuleb jälgida kasutusjuhendis sisalduvad instalationimärkmeid. Juhul kui tekkivad raskused keelega, siis pöörduge palun tootja poole. Tootja saadab emakeelse tõlge vastavalt artiklile ning maale.



Notas sobre la instalación de cadenas de medición en un entorno potencialmente explosivo.

Si ha de instalar la cadena de medición en un entorno potencialmente explosivo, deberá respetar las indicaciones sobre la instalación, contenidas en el manual de uso. Si surgieran dificultades lingüísticas, póngase en contacto con la empresa fabricante, que le facilitará una traducción del artículo en la lengua del país donde se emplee.



Note on the installation of the measuring chains in an explosive environment

If the measuring chain is supposed to be installed in an explosive environment, it is important to follow the pertinent installation instructions in the manual. Should you encounter difficulties with the language, please contact the manufacturer to obtain a translation of the relevant paragraphs into the language required.



Σημείωση για την εγκατάσταση αλισιδών μέτρησης σε περιβάλλον, στο οποίο υπάρχει κίνδυνος έκρηξης
Εάν η αλισουδα μέτρησης πρόκειται να εγκατασταθεί σε περιβάλλον, στο οποίο υπάρχει κίνδυνος έκρηξης, πρέπει να τηρηθούν οπωσδήποτε οι οδηγίες εγκατάστασης που περιλαμβάνονται στις οδηγίες Χρήσης. Εάν υπάρχουν γλωσσικές δυσκολίες καταούησης, παρακαλούμε να απευθυνθείτε στην κατασκευάστρια εταιρεία, η οποία θα φρουτίσει για την αποστολή μιας μετάφρασης των σχετικών άρθρων στη γλώσσα της Χώρας Χρήσης.



Info vedrørende installation af målekæderne i eksplosionstruede omgivelser

Hvis målekæden skal installeres i eksplosionstruede omgivelser, skal installationsanvisningerne i brugsanvisningen følges. Hvis der i denne forbindelse opstår sproglige problemer, bedes De henvende Dem til produktionsfirmaet, som så vil sørge for, at De modtager en oversættelse af den relevante artikel på Deres sprog.



Poznámka k instalaci měřicích řetězců v prostředí s nebezpečím výbuchu.

Když má být měřicí řetězec (sestavující z čidla a konvertoru) instalován v prostředí s nebezpečím výbuchu, tak je třeba respektovat instalační pokyny, které jsou součástí návodu k upotřebení. Kdyby při tom došlo k jazykovým potížím, tak prosíme kontaktujte výrobní firmu, která Vám relevantní články zašle v jazyku krajiny použití.



Piezīme par mērišanas ķēžu instalēšanu sprādziena bīstamās zonās.

Ja mērišanas ķēde jāuzstāda sprādzienbīstamā zonā, ir jāievēro lietošanas instrukcijā dotie instalēšanas norādījumi. Ja rodas kādas valodas grūtības, lūdzu griezieties pie izgatavotāja firmas, kas Jums nosūtīs nozīmīgāko nodaļu tulkojumus lietotāja valsts valodā.

Emerson
epro GmbH
Jöbkesweg 3
48599 Gronau
Germany
T +49 2562 709 0
F +49 2562 709 401
www.Emerson.com

Contents

Chapter 1	General.....	9
	1.1 Using this manual.....	9
	1.2 Symbols.....	9
	1.3 Liability and guarantee.....	10
	1.4 Incoming goods inspection.....	10
	1.5 Technical support.....	10
	1.6 Storage and transport.....	11
	1.7 Disposal of the device.....	11
	1.8 China RoHS Compliance.....	11
	1.9 CCC Certification – AMS 6500 ATG.....	12
	1.10 Installation awareness.....	12
Chapter 2	Safety instructions.....	14
	2.1 Using the device.....	14
	2.2 Owner's responsibility.....	14
	2.3 Radio interference.....	15
	2.4 ESD safety.....	15
Chapter 3	Application and design.....	16
	3.1 Application.....	16
	3.2 Design.....	17
Chapter 4	Installation.....	20
	4.1 Commissioning.....	20
	4.2 CSA - General safety.....	20
Chapter 5	Hazardous location installation.....	21
Chapter 6	Configuration.....	22
	6.1 General configuration procedure.....	22
	6.1.1 Offline configuration overview.....	22
	6.1.2 Online configuration overview.....	22
	6.2 Start of an offline card configuration.....	23
	6.3 Start of an online card configuration.....	24
	6.4 Dialog New Configuration	25
	6.5 Configuration of an already existing card.....	30
	6.6 Configuration editor and parameters.....	30
	6.6.1 Ribbon command bar.....	31
	6.6.2 Overview.....	35
	6.6.3 Basic.....	36
	6.6.4 Input 1 and Input 2.....	37
	6.6.5 Linearization 1 and Linearization 2.....	43

6.6.6	Digital inputs.....	44
6.6.7	Measurement 1 and Measurement 2.....	47
6.6.8	Analysis 1 and Analysis 2.....	62
6.6.9	Run-up / run-down 1 and Run-up / run-down 2.....	66
6.6.10	Current output 1 and Current output 2.....	66
6.6.11	Alarm limits 1 and Alarm limits 2.....	71
6.6.12	Digital outputs.....	87
6.6.13	Speed.....	88
6.7	Send and reload a configuration.....	114
6.7.1	Send a configuration.....	115
6.7.2	Reload a configuration.....	116
Chapter 7	Online view.....	117
7.1	Static and dynamic measurement applications.....	118
7.1.1	Overview.....	118
7.1.2	Details.....	129
7.1.3	Live data.....	136
7.2	Online view - speed application.....	140
7.2.1	Overview.....	140
7.2.2	Details.....	146
7.2.3	Live data.....	151
7.3	Online commands.....	151
7.3.1	Static and dynamic measurement applications.....	152
7.3.2	Speed applications.....	153
Chapter 8	Functions.....	156
8.1	Channel OK supervision.....	156
8.1.1	Eddy current measuring chains and A6500-LC.....	159
8.1.2	Piezoelectric sensors.....	160
8.1.3	Seismic sensors.....	160
8.1.4	Bearing vibration sensors LF-24 and JVP-05-08.....	161
8.1.5	Dynamic pressure sensor CP 103 with IPC 704 and GSI 127 (voltage input – pressure).....	162
8.1.6	Hall-effect sensor PR 9376 with load resistors.....	162
8.1.7	VR sensors.....	163
8.1.8	Static pressure sensors – Bently Nevada 165855.....	163
8.2	Current outputs.....	164
8.3	Digital in- and outputs.....	165
8.4	Sensor raw signal outputs.....	167
8.5	Key-signal output / input.....	167
8.6	Trigger threshold limit detection.....	167
8.6.1	Manual limit definition.....	167
8.6.2	Automatic limit detection.....	168
8.7	Acceleration measurement.....	168

8.8	Peak and Phase.....	169
8.9	PeakVue.....	171
8.10	Recording of run-ups or run-downs.....	171
8.11	Bypass.....	172
Chapter 9	Applications.....	175
9.1	Single-channel applications.....	175
9.1.1	Single-channel – shaft vibration.....	175
9.1.2	Single-channel – case vibration with seismic sensors.....	177
9.1.3	Single-channel – case vibration with piezoelectric sensors.....	180
9.1.4	Single-channel – shaft position.....	182
9.1.5	Single-channel – shaft position with reduced measuring range.....	186
9.1.6	Single-channel – Rod Drop.....	189
9.1.7	Single-channel – eccentricity S_{pp}	198
9.1.8	Single-channel – eccentricity minimum/maximum.....	201
9.1.9	Single-channel – housing expansion.....	206
9.1.10	Single-channel – speed measurement.....	208
9.1.11	Single-channel – key generation.....	216
9.1.12	Single-channel – dynamic pressure.....	220
9.1.13	Single-channel – cylinder pressure.....	222
9.1.14	Vibration (low frequency) with order analysis.....	224
9.2	Combined channel applications.....	226
9.2.1	Combined channels – shaft vibration S_{max}	226
9.2.2	Combined channels – shaft vibration S_{maxPP}	229
9.2.3	Combined channels – shaft position Cone 1 and Cone 2.....	232
9.2.4	Combined channels – shaft position Double Cone 1.....	240
9.2.5	Combined channels – shaft position Double Cone 2.....	248
9.2.6	Combined channels – shaft position Tandem.....	256
9.2.7	Combined channels – shaft position Min/Max.....	267
9.2.8	Combined channels – absolute shaft expansion.....	271
9.2.9	Combined channels – absolute shaft vibration.....	273
9.2.10	Combined channels – cylinder pressure.....	275
9.2.11	Combined channels – housing expansion Add/Sub.....	277
9.2.12	Combined channels – Rotational direction.....	280
Chapter 10	Functional check and maintenance.....	283
10.1	Functional check.....	283
10.1.1	Card check procedures.....	283
10.1.2	Measure the current output.....	289
10.1.3	Simulation mode.....	290
10.2	Maintenance.....	293
Chapter 11	Replace an Universal Measurement Card.....	294

Chapter 12	Technical data.....	295
	12.1 Power supply.....	295
	12.2 Sensor connection.....	295
	12.3 Digital input.....	299
	12.4 Outputs.....	299
	12.5 Data interface.....	300
	12.6 Mechanical design and environmental conditions.....	301
Chapter 13	Certificates.....	303
Appendix A	Card related system events.....	314
Index	317

1 General

1.1 Using this manual

This manual contains information concerning the use of the device.

Read the operating manual completely prior to starting installation and operating the device. Comply with all safety instructions.

This operating manual applies for A6500-UM Universal Measurement Cards with hardware revisions and software versions listed in [Table 1-1](#).

Table 1-1: Hardware and software revisions

Hardware revision ¹	Firmware version	AMS Machine Studio version
03, 04, 05, 06, 07, 08 ² , 09, and 12 ³	3.3.0.124, 3.4.0.132, 3.5.0.158 or later ⁴	3.8

¹ See type plate for revision level.

² Speed configurations for revision 07 or earlier are not compatible with revision 08 or later. See [Speed](#).

³ Requires AMS Machine Studio version 3.7 or later and one of the listed firmware versions.

⁴ Requires an A6500-CC with firmware version 3.x.

Include the operating manual when transferring the device to third parties.

Note

When requesting technical support, please indicate type and serial number from the type plate.

[Table 1](#) shows a list of documents that are referred to in this operating manual.

Table 1-2: Referenced documents

MHM- 97875	Operating Manual A6500-CC Com Card
MHM- 97878	Operating Manual A6500-LC LVDT Converter
MHM-97877	Operating Manual A6500-xR System Racks
MHM-97879	Operating Manual AMS Machine Studio - General Function

1.2 Symbols

Note



This symbol marks passages that contain important information.

CAUTION

This symbol marks operations that can lead to malfunctions or faulty measurements, but will not damage the device.

⚠ DANGER

A danger indicates actions that can lead to property damage or personal injury.

	According to IEC 61010, this symbol means that this device must be operated with DC voltage.
	According to IEC 61010, this symbol means that the documentation of the device must completely be read and understood before installing and commissioning of the device. Observe all safety related instructions in this document.

1.3 Liability and guarantee

Emerson is not liable for damages that occur due to improper use. Proper use also includes the knowledge of, and compliance with, this document.

Customer changes to the device that have not been expressly approved by Emerson will result in the loss of guarantee.

Due to continuous research and further development, Emerson reserves the right to change technical specifications without notice.

1.4 Incoming goods inspection

Check the content of the shipment to ensure that it is complete; visibly inspect the goods to determine if the device has been damaged during transport. The following parts are included in the scope of delivery and must be contained in the shipment.

- Monitor Card
- Operating manual

If the contents are incomplete, or if you observe any defects, file a complaint with the carrier immediately. Inform the responsible Emerson sales organization so your device can be replaced. In this case, attach a tag with customer name and the observed defect.

1.5 Technical support

You may need to ship this product for return, replacement, or repair to an Emerson Product Service Center. Before shipping this product, contact Emerson Product Support to obtain a Return Materials Authorization (RMA) number and receive additional instructions.

Product Support

Emerson provides a variety of ways to reach your Product Support team to get the answers you need when you need them:

Phone	Toll free 1 800 833 8314 (U.S. and Canada) +1 512 832 3774 (Latin America)
--------------	---

+63 2 8702 1111 (Asia Pacific, Europe, and Middle East)

Email Guardian.GSC@Emerson.com

Web <http://www.emerson.com/en-us/contact-us>

To search for documentation, visit <http://www.emerson.com>.

To view toll free numbers for specific countries, visit <http://www.emerson.com/technicalsupport>.

Note

If the equipment has been exposed to a hazardous substance, a Material Safety Data Sheet (MSDS) must be included with the returned materials. An MSDS is required by law to be available to people exposed to specific hazardous substances.

1.6 Storage and transport

Store and transport the device only in its original packaging. Technical data specifies the environmental conditions for storage and transport.

Related information

[Technical data](#)

[Power supply](#)

[Sensor connection](#)

[Digital input](#)

[Outputs](#)

[Data interface](#)

[Mechanical design and environmental conditions](#)

1.7 Disposal of the device

Provided that no repurchase or disposal agreement exists, recycle the following components at appropriate facilities:

- Recyclable metal
- Plastic elements

Sort the remaining components for disposal, based on their condition. National laws or provisions on waste disposal and protection of the environment apply.

Note

Environmental hazards! Electrical waste and electronic components are subject to treatment as special waste and may only be disposed by approved specialized companies.

1.8 China RoHS Compliance

Our products manufactured later than June 30, 2016, and those which are sold in the People's Republic of China are marked with one of the following two logos to indicate the

Environmental Friendly Use Period in which it can be used safely under normal operating conditions.

Products that do not have the following marking were either manufactured before June 30, 2026, or are not electrical equipment products (EEP).



Circling arrow symbol with "e": The product contains no hazardous substances over the Maximum Concentration Value and it has an indefinite Environmental Friendly Use Period.



Circling arrow symbol with a number: This product contains certain hazardous substances over the Maximum Concentration Value and it can be used safely under normal operating conditions for the number of years indicated in the symbol. The names and contents of hazardous substances can be found in chapter "Certificates".

1.9 CCC Certification – AMS 6500 ATG

With the announcement of the Chinese market regulation authority SAMR (State Administration for Market Regulation), a Compulsory Product Certification (CCC certification) is mandatory for many explosion protection products. This explosion proof ("Ex") product complies to the CCC obligation and is certified (certification number: 2020322304002386).



This China Compulsory Certificate mark (CCC), is a compulsory safety mark for many products imported, sold, or used in the Chinese market and indicates that the product is certified in accordance to GB/T 3836.1-2021, GB/T 3836.3-2021, and GB/T 3836.8-2021. If the product label is too small to contain the CCC certification mark, it is sufficient to have the mark printed on the minimum package and in the attached document.

1.10 Installation awareness

Note

When planning a measurement, follow these guidelines:

- Consider environmental conditions which might have an influence on the measurement such as temperature, humidity, substances aggressive to the sensor, and pollution.
- Always use a stiff and vibration-free sensor holder.
- Define a suitable measuring range, not larger than necessary, in consultation with the operator of the plant.
- Define the trip limit in consultation with the operator of the plant.
- Take measurement deviations into account when defining trip limits.
- Use a sensor that meets the requirements of the defined measuring range.
- Ensure an EMC-compatible installation including the use of proper cables.

- Ensure proper function of the measurement before activating the measurement in the production environment.
-

2 Safety instructions

To ensure safe operation, carefully follow all the instructions in this manual.

The correct and safe use of this device requires that both operating and service personnel understand and comply with general safety guidelines and observe the special safety comments listed in this manual. Where necessary, safety-sensitive points on the device are marked.

⚠ DANGER

Because the device is electrical equipment, only specially trained and authorized personnel may commission, service, and maintain this equipment.

2.1 Using the device

Install and use the device as specified in this document.

If the device is used in a manner not specified by the manufacturer, the functions and protection provided by the device may be impaired.

2.2 Owner's responsibility

If there is a reason to suspect that hazard-free operation, and thus, adequate machine protection is no longer possible, take the device out of operation and safeguard it from unintentional operation. This is the case:

- if the device shows visible damage.
- if the device no longer works.
- after any kind of overload that has exceeded the permissible limits (see technical data of the device for permissible limits).

⚠ DANGER

If device tests have to be completed during operation or if the device has to be replaced or decommissioned, it will impair the machine protection and may cause the machine to shut down. Make sure to deactivate machine protection before starting such work, and reactivate it after work has been completed.

Related information

[Technical data](#)

[Power supply](#)

[Sensor connection](#)

[Digital input](#)

[Outputs](#)

[Data interface](#)

[Mechanical design and environmental conditions](#)

2.3 Radio interference

The device is carefully shielded and tested to be technically immune to radio interference and complies with current standards. However, if you operate this device together with other peripheral devices that are not properly shielded against radio interference, disturbances and radio interferences may occur.

2.4 ESD safety

DANGER

Internal components can be damaged or destroyed due to electrostatic discharge (ESD) during the handling of the device.

Take suitable precautions before handling the device to prevent electrostatic discharges through the electronics. Such measures might include, for example, wearing an ESD bracelet. Transport and storage of electronic components may only be made in ESD-safe packaging.

Handle the device with particular care during dry meteorological conditions with relative humidity below 30% as electrostatic discharges can occur more frequently.

3 Application and design

3.1 Application

The two-channel A6500-UM Universal Measurement Card is a component of the AMS 6500 ATG system. The card is an universal card for measuring of dynamic values, static values, and speed. [Table 3-1](#) lists measuring tasks with corresponding sensor types.

Table 3-1: Overview of measuring applications

Measuring groups	Measuring applications	Sensor
Dynamic	Relative shaft vibration	Eddy current sensor
	Bearing vibration	Electrodynamic (seismic) or piezoelectric sensor
	Absolute shaft vibration	Eddy current and seismic or piezoelectric sensor
	Dynamic pressure	Meggitt model CP 103 with IPC 704 and GSI 127 or PCB model 121A45
Static	Shaft position, expansion	Eddy current sensor
	Housing expansion	Linear displacement transducer with A6500-LC converter
	Valve position	Linear displacement transducer with A6500-LC converter
	Absolute shaft expansion	Eddy current sensor and linear displacement transducer with A6500-LC converter
	Eccentricity	Eddy current sensor
	Rider band wear in reciprocating machines	Eddy current sensor
Speed	Speed	Eddy current sensor, Hall-effect sensor, or VR sensor ¹
	Detection of rotational direction	Eddy current sensor, Hall-effect sensor, or VR sensor ¹
	Generation of key-signals	Eddy current sensor, Hall-effect sensor, or VR sensor ¹

¹ Variable Reluctance Sensor, also known as MPU (magnetic pickup)

The two channels of the card can be configured for separate measurements or linked together, except for speed applications. At speed applications, both channels are used for speed measurements. Combination of speed and other measurements as, for example, dynamic measurements at one card is not possible. The measured values can be monitored for limit violations and output by 0/4 to 20 mA current outputs. Channel OK (COK) and alarm state information are provided by binary outputs. In conjunction with the A6500-CC COM Card data such as measured values, limit values, or status data can be provided as Modbus data or through OPC UA. The Universal Measurement Card is designed for use in the A6500-xR System Racks (A6500-SR, A6500-RR, or A6500-FR). The Com Card is required for the configuration.

Note

The A6500-UM card is equipped with filters such as Butterworth filters (as required by ISO 10816) for the signal processing. Depending on the complexity of the measured input signal, the use of the filters can cause phase shifts.

3.2 Design

The A6500-UM Universal Measurement Card is designed as standard Euro board (100 mm x 160 mm) with an anodized front plate of 6 HP (approximately 30 mm) and is equipped with a 48-pole connector (IEC 60603-2, F 48 M). The card is designed for use in the A6500-xR System Racks. [Figure 3-1](#) shows the side view of the Universal Measurement Card.

Figure 3-1: Side view

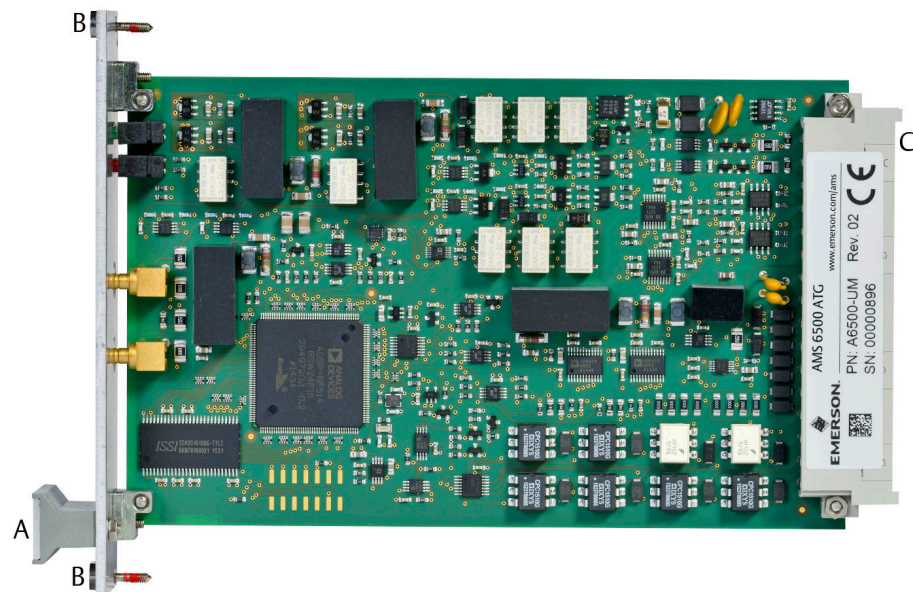

- A. Handle - for pulling the monitor from the rack; labeled with the serial number on a small sticker.
- B. Mounting screws
- C. Connector with type plate with designation (PN), serial number (SN), and hardware revision (Rev.).

[Figure 3-2](#) shows the front plate elements. The elements marked with 1 on the front panel (LEDs, SMB sockets) refers to channel 1 and the elements marked with 2 refer to channel 2.

Figure 3-2: Front view

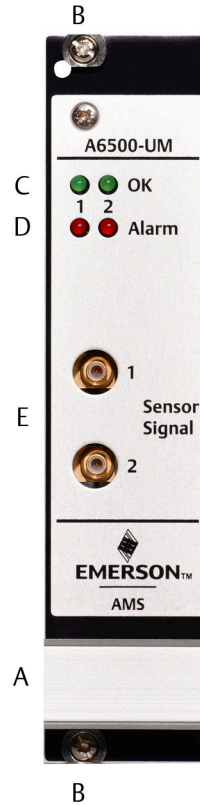

- A. Handle
- B. Mounting screws
- C. green LEDs: Card status indication
- D. red LEDs: Alarm status
- E. Coaxial sockets (SMB socket connectors) for raw sensor signal

Overview blinking pattern LEDs

Table 3-2 provides an overview about the blinking pattern of the two green card status LEDs and the two red alarm status LEDs.

Table 3-2: Blinking pattern LEDs

Event	Blinking pattern
No power supply	All LEDs (Card status and alarm status LEDs) are off.
Start up phase	Synchronously flashing of the card status LEDs (see Channel OK supervision).
Not configured	Alternated flashing of the card status LEDs (see Channel OK supervision).

Table 3-2: Blinking pattern LEDs (continued)

Event	Blinking pattern
Boot loader active	Alternated flashing of the alarm status LEDs (see Channel OK supervision).
Alert alarm	Alarm status LED of the corresponding channel is flashing. With calculation based on two channels both alarm status LEDs are flashing (see Alarm limits 1 and Alarm limits 2).
Danger alarm	Alarm status LED of the corresponding channel is on. With calculation based on two channels both alarm status LEDs are on (see Alarm limits 1 and Alarm limits 2).
Channel not OK	Card status LED of the corresponding channel is off (see Channel OK supervision).
Wrong module type	Alternated flashing of the card status LEDs and alarm status LEDs.
Online command Identify	Circular blinking of all four LEDs (see Static and dynamic measurement applications).

4 Installation

For installation and mounting of A6500-xR System Racks, sensor connection, and wiring see operation manual of the A6500-xR System Racks.

1. Select one slot out of the eleven protection card slots 1 to 11.
2. Wire the slot in accordance to the measuring task (sensor connection, digital inputs and outputs, and so on).
3. Push the card into the prepared slot.
4. At the front plate, secure the card by gently fastening the screws to hand tight.

Note

The AMS 6500 ATG cards are hot-swappable. It is not necessary to switch off the power supply of the system rack for installing or replacing cards.

CAUTION

Any work at the system may impair machine protection.

4.1 Commissioning

Procedure

1. If the card is not configured, create a configuration in AMS Machine Studio and download it to the card (see [Configuration](#)).
2. Ensure proper measurement by checking input and output signals (see [Functional check](#)).

4.2 CSA - General safety

Conditions of acceptability

See chapter "CSA - General safety" of the A6500-xR System Racks operating manual (MHM-97877) for conditions of acceptability.

5 Hazardous location installation

The ex-approval of the A6500-UM Universal Measurement Card is only valid if the Universal Measurement Card is installed in an A6500-xR System Rack. See chapter "Hazardous location installation" of the A6500-xR System Racks operating manual (MHM-97877) for details.

6 Configuration

6.1 General configuration procedure

The configuration can be performed offline, without connection to the card or online, with a connection to the card. In any case, the configuration has to be loaded into the card. The A6500-CC Com Card is required for the configuration procedure. See Com Card operating manual for details.

Requirements:

- A6500-CC Com Card
- USB cable with Type-A and Type-B plug or Ethernet cable
- AMS Machine Studio (configuration software)
- PC or laptop with Microsoft Windows 10

6.1.1 Offline configuration overview

Procedure

1. Start AMS Machine Studio.
2. Enter configuration parameter according to the measuring task.
3. Save the configuration.

When you are able to connect to the system, you can load the saved configuration file to the card (see [Send a saved configuration file to the card](#)).

Send a saved configuration file to the card

Procedure

1. Switch on the power supply of the system if not already on.
2. Connect the laptop to the Com Card of the system by using the USB or Ethernet connection.
3. Start AMS Machine Studio.
4. Select the card to be configured and click **Configure**.
5. Open the saved configuration file (window **File**, menu item **Open**).
6. Send the configuration to the card.
7. Close AMS Machine Studio and disconnect the connection to the Com Card.
After these steps, the Universal Measurement Card is ready for operation.

6.1.2 Online configuration overview

Procedure

1. Switch on the power supply of the system if not already on.

2. Connect the laptop to the Com Card of the system by using the UBS or Ethernet connection.
3. Start AMS Machine Studio.
4. Select the card to be configured and click **Configure**.
5. Enter the configuration parameters according to the measuring task.
6. Send the configuration to the card.
7. Save the configuration (if needed).
8. Close AMS Machine Studio and disconnect the connection to the Com Card.
After these steps, the Universal Measurement Card is ready for operation.

6.2 Start of an offline card configuration

These steps are the same for all measurement applications.

Procedure

1. Select **Workspace** in the left part of the **Home** window then click **Item** (see [Figure 6-1](#)). A list with all available system devices opens.

Figure 6-1: Start new device configuration

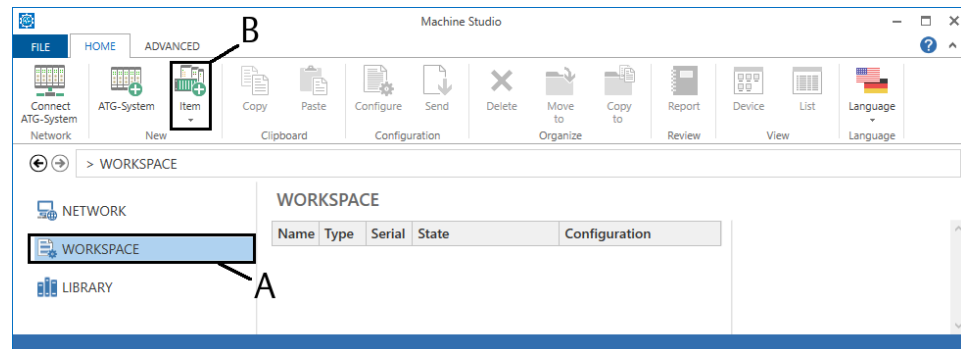

- A. *Workspace*
- B. *Button Item*

2. Select the A6500-UM card from the device list (see [Figure 6-2](#)).

Figure 6-2: Device selection

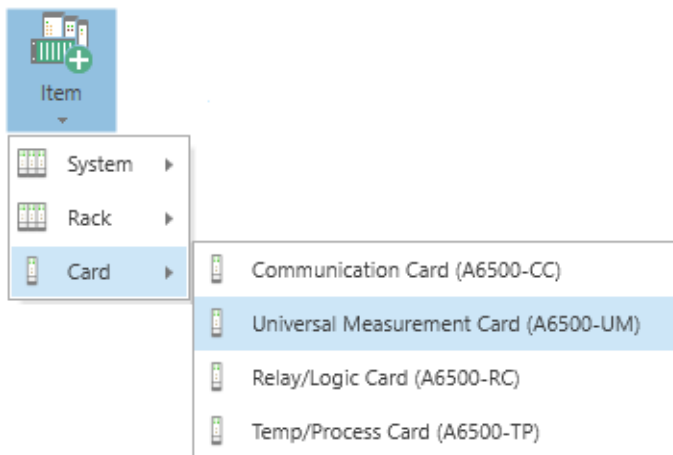

The Universal Measurement Card is added to the list below **Workspace**.

3. Select **Universal Measurement Card (A6500-UM)** from the device list and click **Configure** (see Figure 6-3).

Figure 6-3: Open Editor

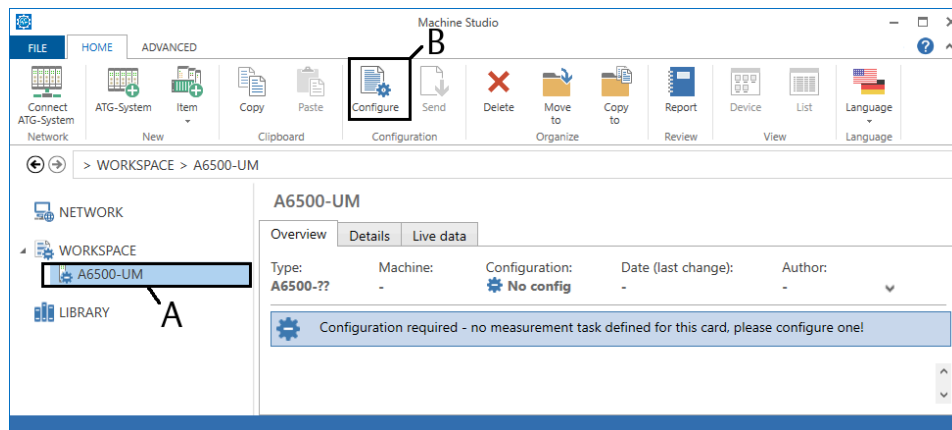

- A. New A6500-UM card.
- B. Button **Configure** to open the configuration editor.

The window for the selection of the measuring application opens.

4. Select an application.
5. Click **Create Configuration** to open the configuration.
See chapter [Configuration editor and parameters](#) for parameter description and settings, depending on the selected measurement application.

6.3 Start of an online card configuration

These steps are the same for all measurement applications

Procedure

1. Select the A6500-UM card from the **Network** list in the left part of the **Home** window, then click **Configure** (see [Figure 6-4](#)).

Figure 6-4: Select a card for online configuration

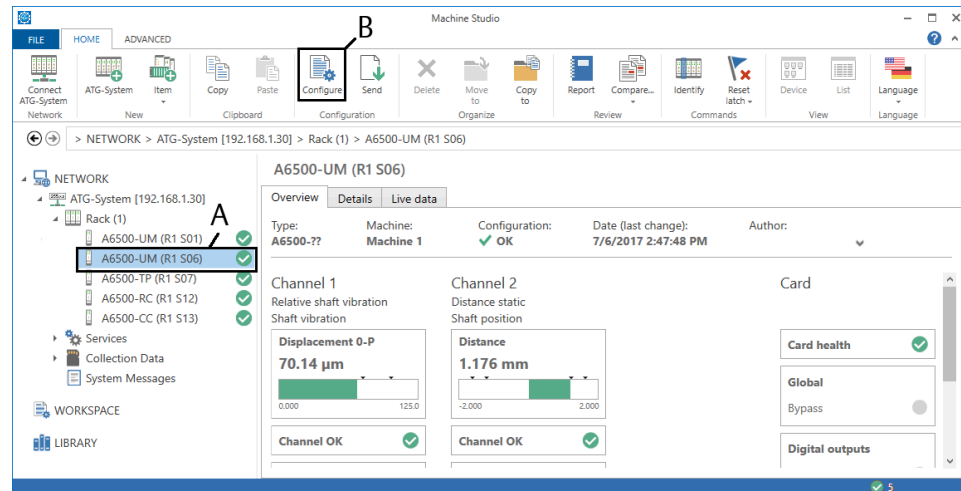

- A. Selected A6500-UM card.*
*B. Button **Configure** for opening the configuration editor.*

The window for the selection of the measuring application opens if an unconfigured card has been selected (see [Dialog New Configuration](#)) otherwise the editor with the configuration of the card directly opens.

2. Select an application. This step and the next step can be skipped if the editor has been directly opened.
3. Click **Create Configuration** to open the configuration.
See chapter [Configuration editor and parameters](#) for parameter description and settings, depending on the selected measurement application.

6.4 Dialog New Configuration

The dialog for the selection of the measuring application opens if an unconfigured A6500-UM card has been selected or **New Configuration** has been clicked at an already detected Universal Measurement Card (see [Figure 6-5](#)).

Figure 6-5: Application selection window

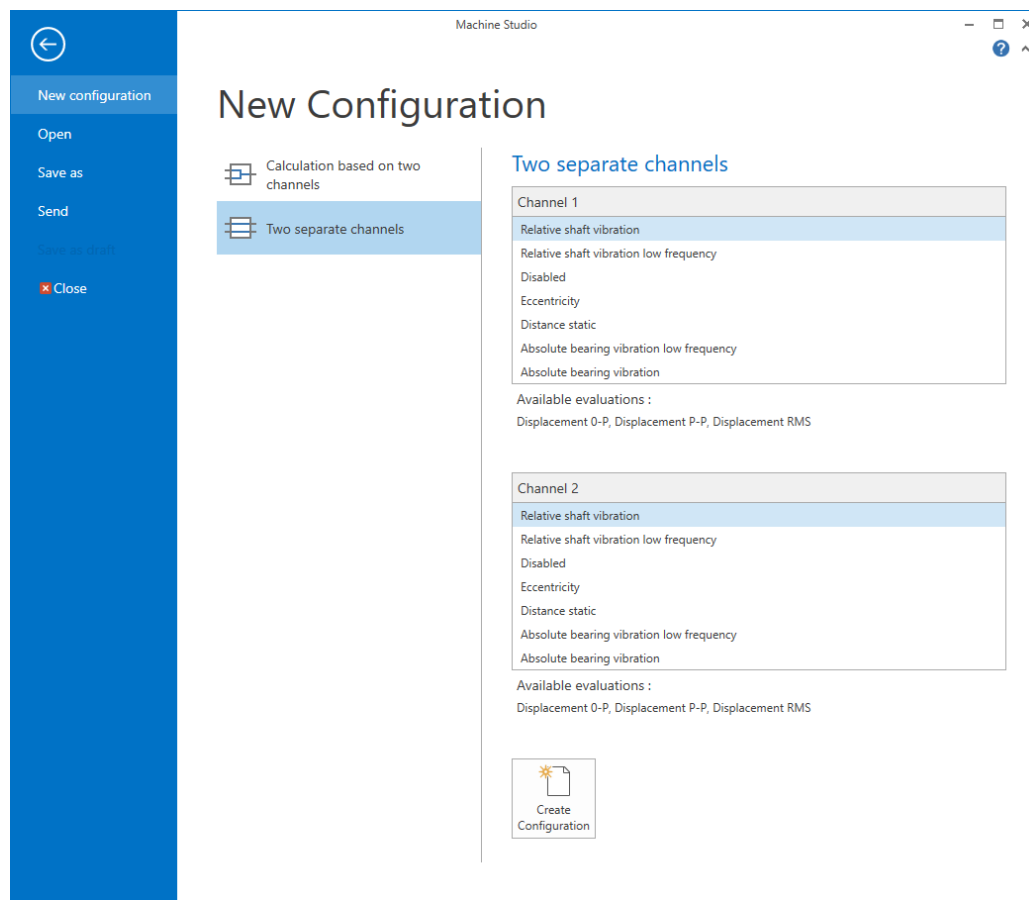

See [Table 6-1](#) and [Table 6-2](#) for the available applications. The applications are divided into the groups:

- **Calculation based on two channels**
The measurement value is calculated from the measurement value of the single channels.
- **Two separate channels**
Each channel can be configured for arbitrary measurements. Select **Disable** if one channel is not used.

See [Applications](#) for a detailed application description.

Table 6-1: Measurement applications - calculation based on two channels

Application	Short description
Absolute Shaft vibration	The first channel measures the absolute bearing vibration with an seismic - or piezoelectric sensor. The second channel measures the relative shaft vibration with an eddy current measuring chain. The measurement value is calculated form these single values.

Table 6-1: Measurement applications - calculation based on two channels (continued)

Application		Short description
Tandem / cone	Relative Shaft Position – Tandem	Measurement with two eddy current measuring chains. Both sensors are mounted at a measuring collar where the collar is between both sensors. The maximum realizable measuring range is nearly double the measuring range compared to a standard position measurement setup.
	Relative Shaft Position – Tandem II	Use this application if you have a Tandem measurement and there are leaps in the intersection point area – when the measurement switches from one sensor to the other. Such leaps can occur with: <ul style="list-style-type: none"> • Large measuring ranges • High changes of the environmental temperature of the measurement • Use of eddy current measuring chains with an extended measuring range Setup and configuration of the Tandem II measurement is identical with the Tandem measurement, except Intersection point auto mode and Intersection point – these parameters are not needed. Overlapping of both measuring ranges is also not necessary. The applications differ in the internal detection of the intersection point.
	Relative Shaft Position – Cone 1 and Cone 2	Measurement with two eddy current measuring chains. One sensor is mounted at a cone and the second one at the shaft. Higher total measuring range compared to a standard position measurement setup because of the cone angle. Difference cone 1 and cone 2: second sensor is mounted at the shaft with a radial setup of 180°.
	Relative Shaft Position – Double cone 1	Measurement with two eddy current measuring chains. Both sensors are mounted at a cone with a radial offset of 180°. Higher total measuring range compared to a standard position measurement setup because of the cone angle.
	Relative Shaft Position – Double cone 2	Measurement with two eddy current measuring chains. Both sensors are mounted at a double cone. Higher total measuring range compared to a standard position measurement setup because of the cone angle.
	Relative Shaft Position – Min/Max	Measurement with two eddy current measuring chains. Value Max: the greater one of the two values will be output Value Min: the lower one of the two values will be output
	Absolute Housing Expansion Add/Sub	Both channels measure with linear displacement transducers in combination with A6500-LC converter the absolute housing position. The measurement value is the addition or subtraction of these values.

Table 6-1: Measurement applications - calculation based on two channels (continued)

Application		Short description
	Absolute Shaft position (difference)	One channel measures the relative shaft position with an eddy current measuring chain and the second channel measures the absolute housing position with a linear displacement transducer in combination with the A6500-LC converter. The measurement value is calculated from these single values.
	Absolute Bearing Vibration – low frequency	Measurement with two seismic- or piezoelectric sensors mounted with a radial offset of 90°. For low frequency ranges. Smax: Measurement value is the geometrical addition of the single channel values. SmaxPP: Measurement value is the highest peak to peak value out of channel 1 or channel 2.
	Absolute Bearing Vibration	Measurement with two seismic- or piezoelectric sensors mounted with a radial offset of 90°. Smax: Measurement value is the geometrical addition of the single channel values. SmaxPP: Measurement value is the highest peak to peak value out of channel 1 or channel 2.
	Relative Shaft Vibration	Measurement with two eddy current measuring chains mounted with a radial offset of 90°. Smax: Measurement value is the geometrical addition of the single channel values. SmaxPP: Measurement value is the highest peak to peak value out of channel 1 or channel 2.
	Relative Shaft Vibration – low frequency	Measurement with two eddy current measuring chains mounted with a radial offset of 90°. For low frequency ranges. Smax: Measurement value is the geometrical addition of the single channel values. SmaxPP: Measurement value is the highest peak to peak value out of channel 1 or channel 2.
	Cylinder pressure	Measurement of cylinder pressure at reciprocating compressors with two chambers with two static pressure sensors. The sensors can be assigned to the crank side of the cylinder or to the head side of the cylinder. The measurement value is calculated from the single sensor signals. This measurement application requires a key-signal.
	Speed	Measurement of machine speed, detection of rotational direction, and key-signal generation at trigger wheels or key marks (no detection of rotational direction) with an eddy current measuring chain, a Hall-effect sensor, or a VR sensor ¹ .

Table 6-1: Measurement applications - calculation based on two channels (continued)

Application	Short description
Redundant speed	Redundant mode of the speed / key-signal measurement. Equip both channels with identical measuring chains respectively identical sensors and create an identical configuration for both channels. The speed or key-pulses will be captured by channel 1 and output on both outputs in parallel. If a channel error is recognized at channel 1 or if more than three pulses in series are missing, the card switched over to the measurement on channel 2. This error will be indicated by the Channel OK output as well as with the accompanying LED of channel 1. For the configuration parameter description see chapter Speed as the parameters are the same for the redundant speed measurement.

1 Variable Reluctance Sensor

Table 6-2: Measurement applications - two separate channels

Application		Short description
Distance static	Distance	Measurement of shaft position, expansion, and general distances with an eddy current sensor. Measurement of housing expansion, valve position, and so on with a linear displacement transducer in combination with the A6500-LC converter.
	Rod Drop Average Mode	Indirect measurement of the rider band (piston ring) wear with a geometrical scaling in reciprocating machines with an eddy current measuring chain.
	Rod Gap	Direct measurement of the rider band (piston ring) wear in reciprocating machines with an eddy current measuring chain.
	Rod Drop Triggered Mode	Indirect measurement of the rider band (piston ring) wear with a geometrical scaling in reciprocating machines with an eddy current measuring chain. The measurement is triggered at a certain position of the piston defined by piston angle and trigger angle. This measurement requires a key signal.
Eccentricity	Eccentricity Peak to Peak	Measurement of the amplitude of the shaft deflection during one rotation with an eddy current measuring chain.
	Eccentricity Minimum/ Maximum	Measurement of the minimum and maximum of the shaft deflection during one rotation with an eddy current measuring chain.
Disabled		Channel is disabled.
Absolute Bearing Vibration		Measurement of the bearing or housing vibration with a seismic- or piezoelectric sensor.

Table 6-2: Measurement applications - two separate channels (continued)

Application	Short description
Absolute Bearing Vibration - low frequency	Measurement of the bearing vibration or housing vibration with a seismic- or piezoelectric sensor. For low frequency ranges.
Relative Shaft Vibration - low frequency	Measurement of the shaft vibration with an eddy current measuring chain. For low frequency ranges.
Relative Shaft Vibration	Measurement of the shaft vibration with an eddy current measuring chain.
Dynamic pressure	Measurement of dynamic pressure with Meggitt model CP 103 with IPC 704 and GSI 127 or PCB model 121A45.
Vibration (low frequency) with order analysis	Measurement of the shaft vibration with an eddy current measuring chain at low frequencies (Lower cutoff frequency range is 0.01 to 0.2 Hz). The analysis function Order analysis including Peak Phase is activated by default for this application.
Cylinder pressure	Measurement of cylinder pressure at reciprocating compressors with a static pressure sensor. This measurement application requires a key-signal.

Procedure

1. Choose an application group and select an application.
2. Click **Create Configuration**.
Based on the selected application, a predefined configuration opens. All of these settings can be changed at a later time.
3. Send this basic configuration to the card before continuing adjusting the parameters to the measuring task (see [Send a configuration](#)).
Now, the card is in the selected application mode. This must be done to continue with some configuration steps as, for example, usage of the automatic trigger threshold limit detection of the speed application.

6.5 Configuration of an already existing card

Procedure

1. Select the card to be reconfigured from the **Network** list.
2. Click **Configure** to open the configuration window.
3. Make the changes to the configuration.
4. Send the configuration to the card (see [Send a configuration](#)).

6.6 Configuration editor and parameters

Figure 6-6 shows an overview of the general configuration editor.

Figure 6-6: Configuration editor

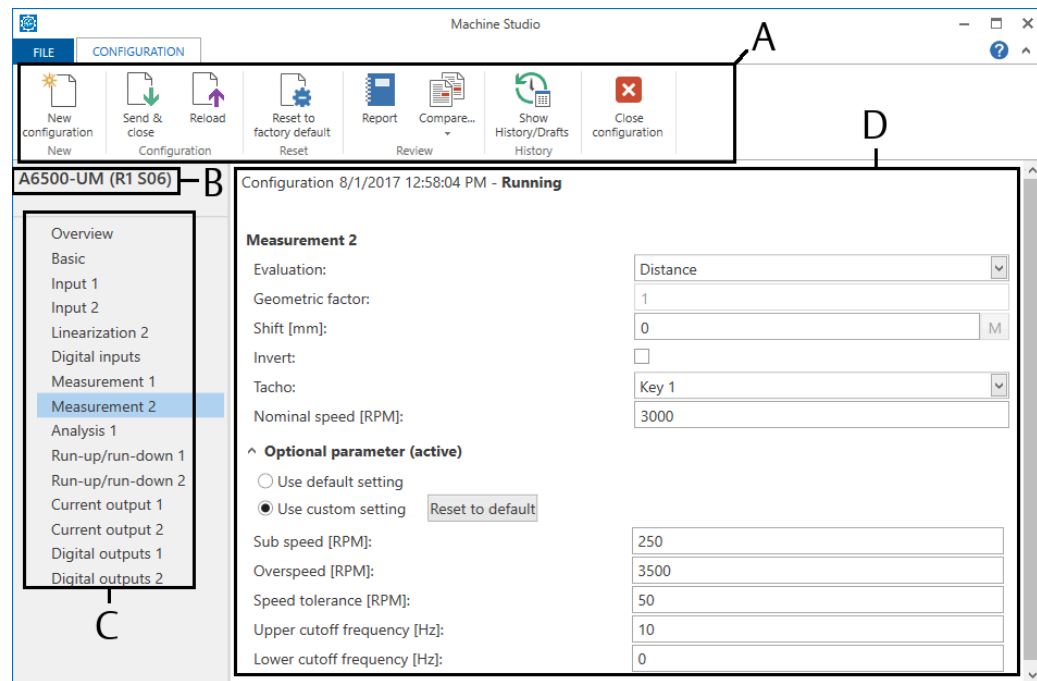

- A. Ribbon command bar
- B. Card name and position within the rack (only visible at connected racks, for example: R1 = Rack 1; S06 = Slot 6)
- C. List of configuration pages
- D. Configuration page

Note

The content of configuration pages, the available parameters, and selectable options depend on the selected measurement application.

6.6.1 Ribbon command bar

New configuration

Figure 6-7: Button "New configuration"

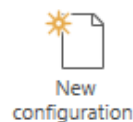

Click **New configuration** to start a new configuration with default parameters.

Send & close

Figure 6-8: Button "Send & close"



Click **Send & close** to send the configuration to the Universal Measurement Card. The configuration editor automatically closes after the sending process. This command requires an online connection to the card. See [Send a configuration](#).

⚠ CAUTION

The machine protection function of the card is disabled during sending of configurations with major changes because of a reboot of the A6500-UM Card.

Reload

Figure 6-9: Button "Reload"



Click **Reload** to reload the configuration from the Universal Measurement Card to the configuration editor.

Reset to factory default

Figure 6-10: Button "Reset to factory default"

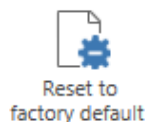

Click **Reset to factory default** to reset the connected Universal Measurement Card to the default parameter settings. After a successful reset the COK LEDs are alternately flashing. Now the card is in the delivery state again. A reset card is marked with the "No configuration" sign in the online view (see [Figure 6-11](#)).

Figure 6-11: No configuration sign



This command requires an online connection to the card.

⚠ CAUTION

The present configuration on the card will be deleted and replaced by the default configuration.

Compare

Figure 6-12: Button "Compare"



Click **Compare** to show differences between the configuration on the card and in the memory of the used Laptop or PC.

Report

Figure 6-13: Button "Report"



Click **Report** to open the report viewer. This report shows all configured parameters and some additional information as, for example, serial number and user information. This report can be exported to different formats as PDF, XPS, and Microsoft Excel or printed.

The logos in the header of the report can be changed.

1. Close the configuration editor.
2. Click tab **File** and then **Settings**.
The window **Settings** opens (see [Figure 6-14](#)).
3. Click the buttons with the dotted line within the **Report settings** area to browse for logos.
Logos with file format "png" or "jpg" can be selected.
4. Click **OK** to confirm your settings.
The window closes.
5. Open the configuration editor and go back to the report.
Now the report contains the selected logos.

Figure 6-14: General settings

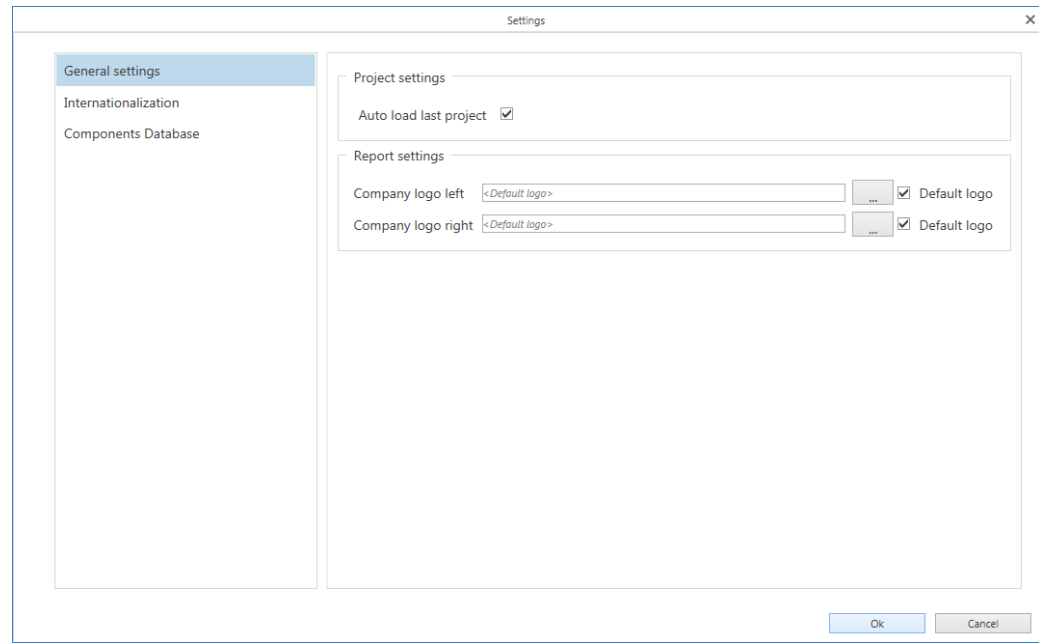

Show History/Drafts

Figure 6-15: Button "Show History/Drafts"



Click **Show History/Drafts** to open the History (see [Figure 6-16](#)).

Figure 6-16: History

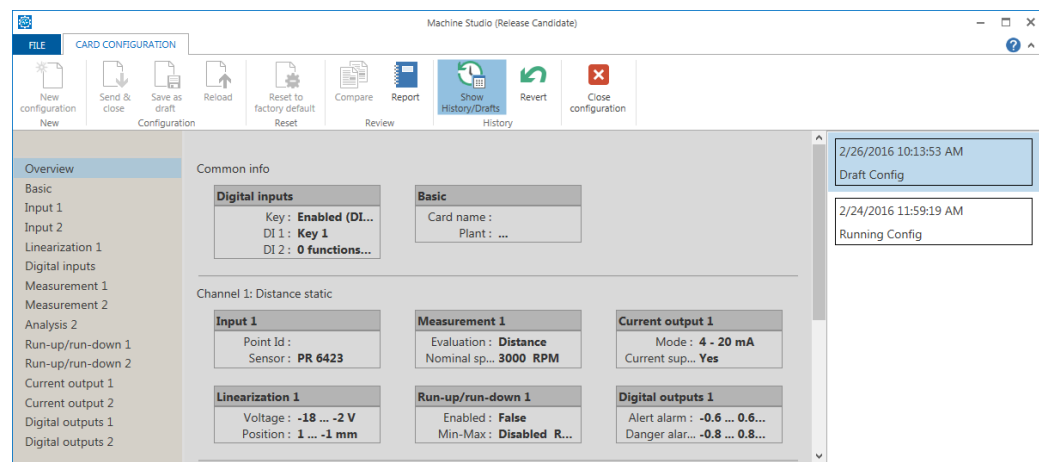

The right part of [Figure 10](#) shows the configuration history. The individual files are marked with date and time and type:

- **Draft Config**
A saved preliminary configuration file which has not yet send onto the card.
- **Running Config**
This configuration file is running on the connected card.
- **Running Config (historic)**
An old configuration file which was running in the past.

The editor area is grayed out. You can see the parameters of the historic files but you can not change them. Parameters can be only changed in the editor. Copying a historic configuration to the editor:

1. Select a draft or historic file from the list by a left mouse click.
The parameter of the selected file are displayed in the grayed out editor area.
2. Click **Revert** (see [Figure 6-17](#)). The selected file is copied to the editor and the history window closes. Click **Show History/Drafts** again, if you want to leave the history without any file copying.

Figure 6-17: Button "Revert"



Revert

Close configuration

Figure 6-18: Button "Close configuration"



Close
configuration

Click **Close** to leave the editor. Changes are automatically saved as a draft configuration. A saved draft can be opened in the history view.

6.6.2 Overview

This page shows an overview of the configuration settings as selected sensors, measurement types, and so on (see [Figure 6-19](#)).

Figure 6-19: Overview

A6500-UM (R1 S06)

Configuration - **Draft***

Overview

- Basic
- Input 1
- Input 2
- Linearization 1
- Digital inputs
- Measurement 1
- Measurement 2
- Analysis 2
- Run-up/run-down 1
- Run-up/run-down 2
- Current output 1
- Current output 2
- Digital output 1
- Digital output 2

Common Info

Digital inputs
Key: **lblDisabled**
DIN1: **Key 1**
DIN2: **0 functions...**

Basic
Card name :
Plant : ...

Channel 1: Distance static

Input 1
Point Id:
Sensor: **PR 6423**

Measurement 1
Evaluation: **Distance**
Nominal sp... **3000 RPM**

Current output 1
Current out... **0 - 20 mA**

Digital output 1
Alert alarm : **-0.6 ... 0.6 m...**
Danger alar... **-0.8 ... 0.8 m...**

Linearization 1
Voltage: **-18 ... -2 V**
Position: **1 ... -1 mm**

Run-up/run-down 1
Enabled: **False**
Min-Max: **Disabled R...**

Channel 2: Relative shaft vibration

Input 2
Point Id:
Sensor: **PR 6423**

Measurement 2
Evaluation: **Displaceme...**
Nominal sp... **3000 RPM**

Current output 2
Current out... **0 - 20 mA**

Digital output 2
Alert alarm : **90 µm**
Danger alar... **120 µm**

Analysis 2
Selected an... **Inactive**

Run-up/run-down 2
Enabled: **False**
Min-Max: **Disabled R...**

For quick access to a single configuration page click the respective field in the overview.

6.6.3 Basic

Enter the basic settings of the configuration (see [Figure 6-20](#)).

Figure 6-20: Basic

A6500-UM (R1 S06)

Configuration 9/17/2020 7:56:34 AM - **Draft**

Overview

- Basic**
- Input 1
- Input 2
- Linearization 2
- Digital inputs
- Measurement 1
- Measurement 2
- Analysis 1
- Run-up/run-down 1
- Run-up/run-down 2
- Current output 1
- Current output 2
- Alarm limits 1
- Alarm limits 2
- Digital outputs

Basic

^ Card

Card name:

User:

Date (last change):

Configuration version:

^ Machine

Machine:

Area:

Plant:

Operation modes:

Operation mode 1 name (default):

Operation mode 2 name:

Operation mode 3 name:

Operation mode 4 name:

The basic settings are divided into the two groups **Card** for card related settings and **Machine** for machine related settings.

Card

Card name	Enter the card name or short description of the measurement.
User	The name of the user who made the last configuration is displayed. The user name of the login data of the operation system is used for this automatic entry. It is not possible to change the content of this field.
Date (last change)	The date and time of the last card configuration is displayed. Time and date of the configuration PC is used. It is not possible to change the content of this field.
Configuration version	The version of AMS Machine Studio used to configure the card is displayed.

Machine

Machine	Enter the machine designation.
Area	Enter a name or short description of the area where the machine is located.
Plant	Enter the plant/factory name.
Operation modes	If your machine has different operating modes, such as a pumped-storage hydro power plant, select the number of different operating modes. Up to four operating modes are configurable. The different operating modes can be activated by digital inputs or Modbus (see Digital inputs). An alarm limit set can be defined per channel for each operating mode (see Alarm limits 1 and Alarm limits 2). This function is available for dynamic measurements. The standard alarm configuration (one Danger alarm and one Alert alarm per dynamic measurement) is active if None is selected.
Operation mode x name	(x = 1 to 4) Enter a name for each operation mode.

6.6.4 Input 1 and Input 2

Define the sensor (see [Figure 6-21](#)). Page **Input 1** is assigned to channel 1 and page **Input 2** is assigned to channel 2. If a dynamic measurement application with calculation based on both channels such as absolute bearing vibration or relative shaft vibration is used, the input configuration of input 1 is also used for input 2. Except **Overwrite sensitivity** and **Point Id**, these parameters can be configured individually for each channel. The available parameters depend on the selected measurement application.

Figure 6-21: Input 1 and Input 2

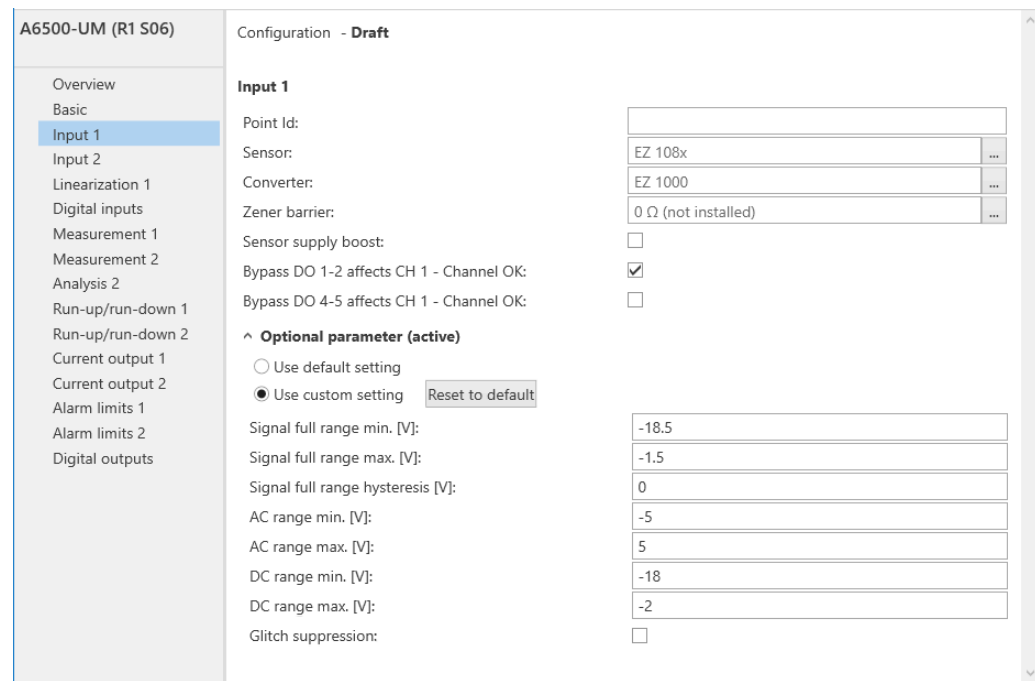



A component data base for sensors, converters, Zener barriers, or target materials is implemented in AMS Machine Studio. To add a missing component:

1. Close the configuration editor.
2. Go to the **File** tab.
3. Click **Settings** to open the settings window.
4. Select **Components Database**.
For further details see operating manual **AMS Machine Studio - General Functions**.
5. Go back to the editor and use the new component for the configuration.

Note

Ensure that the new component meets the connection requirements of the AMS 6500 ATG. See [Sensor connection](#) for details.

- | | |
|------------------|--|
| Point Id | Enter the point ID of the sensor/channel. |
| Sensor | Click selection button  behind the display field to open the sensor selection window. The selectable sensors depend on the chosen measurement application. Select the required sensor type. This is generally the sensor installed at the machine or the sensor stated in the wiring diagram. |
| Converter | For application with eddy current measuring chains or A6500-LC.
Click selection button  behind the display field to open the converter selection window. The selectable converter depends on the chosen |

measurement application. Select the required converter type. This is generally the converter type that is calibrated to the sensor selected before.

Mounting Angle [°]

For seismic (electro-dynamic) sensors.

Enter the mounting angle of the sensor. This parameter is used to compensate angle deviations from the nominal mounting position, respectively, measurement direction. Based on this parameter the required lifting or sinking current for adjustment of the sensor internal measuring element is calculated. Figure 6-22 shows the definition of the angles.

Figure 6-22: Angle definition

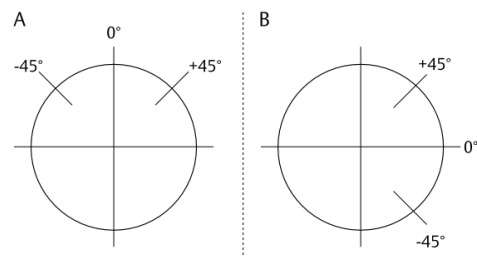

- A. Orientation seismic sensors for vertical measurement direction
- B. Orientation seismic sensors for horizontal measurement direction

Connection type

For piezoelectric and seismic (electrodynamic) sensors. Select the connection type.

- **2-wire**

Choose this option if a two wire sensor is connected. The sensor, depending on the type, is supplied through these two wires. For example, seismic sensors mounted in their nominal measurement direction are not supplied. Seismic sensors mounted out of their nominal direction are supplied through these two wires with a lifting or sinking current. 2-wire piezoelectric sensors are supplied with current through these wires.

- **4-wire**

Choose this option if a sensor is connected with separated supply and signal connections.

Use this setting if the selected sensor can not be supplied by the Universal Measurement Card. In this case, connect only the signal wires and supply the sensor by an external power supply.

Note

Use the 4-wire option when connecting an external function generator to avoid incorrect measurements during tests. See [Card check procedures](#).

Zener barrier For hazardous area installation and VR sensor connection.

Click the selection button  behind the display field to open the Zener barrier selection window, and select a barrier according to the installed barrier from the list.

⚠ DANGER

If a VR sensor is installed, use a suitable Zener barrier to limit the output voltage of the connected VR sensor to avoid damaging the A6500-UM card.

Load resistor For Hall-effect sensor PR 9376.

Click selection button  behind the display field to open the load resistor selection window, and select a load resistor from the list.

A load resistor is an additional circuit component connected to the sensor input to enable channel OK detection at machine standstill, if using PR 9376 Hall-effect sensors. See [Hall-effect sensor PR 9376 with load resistors](#) for further details.

The option **Load resistor 0.5** consists of two 10 kΩ resistors connected to the sensor input as shown on [Figure 6-23](#).

Figure 6-23: Connection of PR 9376 with load resistors

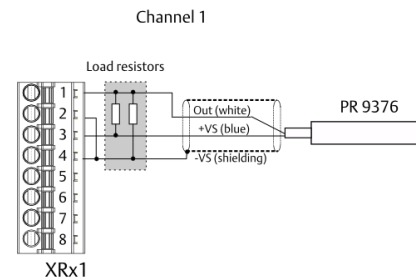

Note

Connect the load resistors as close as possible to the signal input to ensure proper channel OK detection.

The channel OK supervision is deactivated if the option **No load resistor** is selected.

Sensor supply boost

For application with eddy current measuring chains.

Click the checkbox to enable the sensor supply boost. The card generally provides an eddy current sensor supply voltage of -23.25 V DC. The sensor supply voltage is -26.0 V DC, if the box is checked. Activate the boost, for example, if safety barriers are installed or converters which require a higher supply voltage are used.

Channel OK latching

Place a checkmark in the box to activate latching for Channel not OK. If activated, a Channel not OK state is latched unless the state is reset. A

latched Channel not OK state can be reset as soon as the condition for Channel not OK is no longer present. Use a digital input (see [Digital inputs](#)) or a software command (see [Online commands](#)) to reset the latched Channel not OK state.

- Bypass DO 1-2 affects CH 1 - Channel OK** Click the checkbox to enable that a bypassed digital output 1 or 2 affects Channel OK of channel 1. Behavior if a digital output is bypassed:
- Box checked and bypass activated:
The Channel OK (COK) LED of channel 1, on the front is switched off, the assigned digital COK output is opened. All functions related to Channel OK, such as current suppression (**Current output** → **Current suppression**), react accordingly.
 - Box not checked and bypass activated:
An activated bypass does not affect Channel OK of channel 1 and assigned functions.
- Bypass DO 4-5 affects CH 1 - Channel OK** Click the checkbox to enable that a bypassed digital output 4 or 5 affects Channel OK of channel 1. Behavior if a digital output is bypassed:
- Box checked and bypass activated:
The Channel OK (COK) LED of channel 1, on the front is switched off, the assigned digital COK output is opened. All functions related to Channel OK, such as current suppression (**Current output** → **Current suppression**), react accordingly.
 - Box not checked and bypass activated:
An activated bypass does not affect Channel OK of channel 1 and assigned functions.
- Bypass DO 1-2 affects CH 2 - Channel OK and Bypass DO 4-5 affects CH 2 - Channel OK** These settings affects Channel OK of channel 2. See **Bypass DO 1-2 affects CH 1 - Channel OK** and **Bypass DO 4-5 affects CH 1 - Channel OK** for function.
- Bypass affects Channel OK** This option is available for applications with calculation based on two channels. Channel OK of both channels are affected. Click the checkbox to enable that a bypassed digital output affects Channel OK of both channels. Behavior if a digital output is bypassed:
- Box checked and bypass activated:
The Channel OK (COK) LED of channel 1 and channel 2, on the front is switched off, the assigned digital COK outputs are opened. All functions related to Channel OK, such as current suppression (**Current output** → **Current suppression**), react accordingly.
 - Box not checked and bypass activated:
An activated bypass does not affect Channel OK of the channels and assigned functions.

Optional parameter – input

Click the down arrow in front of **Optional parameter** to open additional parameters for the sensor supervision. The available parameters depend on the selected sensor. For a description of the sensor supervision and the default values, see [Channel OK supervision](#).

Use default setting Select this option to use the default setting for the sensor supervision.

Use custom setting Select this option to individually adjust the settings for the sensor supervision.
Click **Reset to default** to reset the settings to the default values.

AC-DC range minimum Enter a lower limit value to define a signal range containing the AC and DC part of the input signal for the sensor supervision. The sensor supervision indicates a not OK status if the AC or DC part of the input voltage is out of the defined OK range.

AC-DC range maximum Enter an upper limit value for the AC-DC range supervision.

AC range minimum Enter a lower limit value to define an AC range for the sensor supervision. The sensor supervision indicates a not OK status if the AC part of the input voltage is out of the defined OK range.

AC range maximum Enter an upper limit value for the AC range supervision.

DC range minimum Enter a lower limit value to define a DC range for the sensor supervision. The sensor supervision indicates a not OK status if the DC part of the input voltage is out of the defined OK range.

DC range maximum Enter an upper limit value for the DC range supervision.

Glitch suppression

⚠ CAUTION

An enabled glitch suppression reduces the sensitivity of the fault detection. Spikes in the sensor signal are no longer detected.

Click the checkbox to enable glitch suppression. This prevents the input channel from improperly losing its OK status due to spikes in the sensor signal. An enabled glitch suppression does not influence the sensor signal used for measurement value calculation and data collection. The glitch suppression function only affects the supervision of the sensor signal.

Such spikes can occur in environments with high electromagnetic fields caused, for example, by electric motors or high voltage cables. It is recommended to shield electromagnetic disturbances with an EMC-compliant installation before using this option. Follow installation instructions in the manual of the used sensor and in the operating manual of the A6500-xR System Racks.

Glitch suppression requires an A6500-UM card with firmware version 3.4.0.131 or higher.

Sensitivity	<p>Available for piezoelectric sensors, piezoelectric pressure sensors, voltage driven piezoelectric sensors, and the sensor Kistler 8209A.</p> <p>Use this entry field to adjust the sensitivity of a piezoelectric sensor without creating a new sensor in the components database. This might be necessary because of possible sensitivity fluctuations that can occur over the time. Enter the current sensitivity of the connected piezoelectric sensor. The sensitivity can be adjusted in a range of $\pm 10\%$ of the default sensitivity of the sensor selected from the components database. The sensitivity of the Kistler 8209A can be adjusted in the range of 5 to 200 mV/pC.</p> <p>If a Kistler sensor is connected, use this parameter to adjust the sensitivity of the charge amplifier.</p> <p>If a dynamic measurement application with calculation based on both channels is used, this parameter is available for both input channels and can be configured individually.</p>
Measuring chain sensitivity	<p>Available for the sensor Kistler 8209A.</p> <p>This field shows the sensitivity of the whole measuring chain consisting of the sensor Kistler 8209A and the charge amplifier 5185A. The sensitivity is calculated from the sensor sensitivity and the charge amplifier sensitivity. The sensitivity of the charge amplifier entered in Sensitivity is used for the calculation.</p>

6.6.5 Linearization 1 and Linearization 2

Use the linearization function for linearization of the static measurement range. Page **Linearization 1** is assigned to channel 1 and page **Linearization 2** is assigned to channel 2 (see [Figure 6-24](#)). Note that the voltages are entered in ascending order. This function is not available for dynamic measurements.

Figure 6-24: Linearization

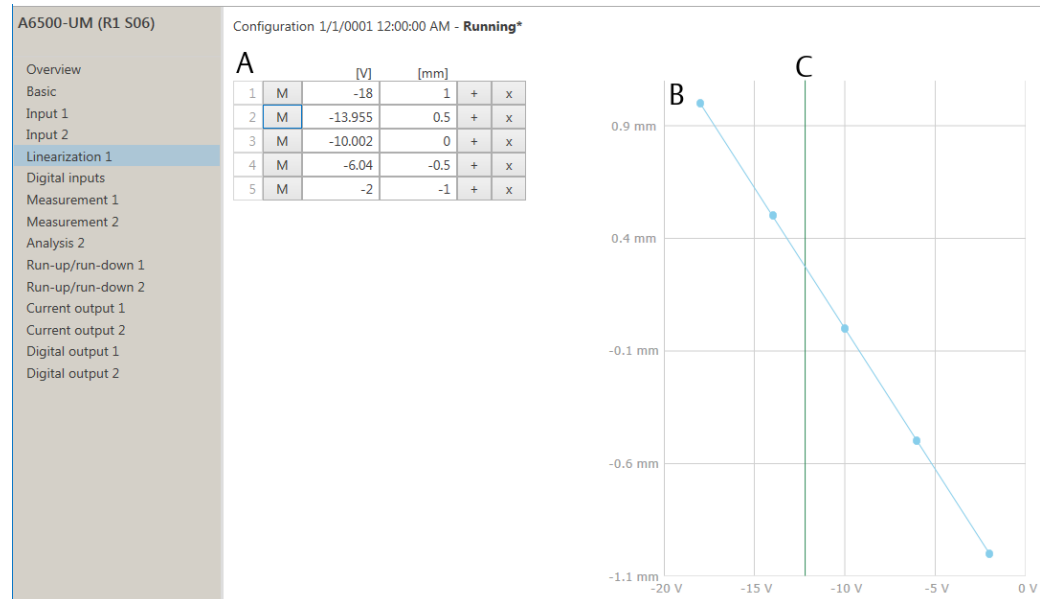

- A. Linearization table with button **M** for measuring the input signal voltage, button **+** for adding rows to the linearization table, and Button **X** for removing rows.
- B. Linearization diagram
- C. The green vertical line indicates the current signal input voltage.

Linearization procedure:

Procedure

1. The default list contains two rows for a two-point linearization. Click on **+** to add the required number of rows. Each row in this table refers to one linearization point. The maximum number of rows is 32. To remove a row click **X** behind the respective row.
2. Enter the positions/displacements in column "[mm]".
3. Adjust precisely this displacement value between sensor and measurement object.
4. Click **M**. The input signal voltage is measured and then entered into the corresponding cell in column "[V]".
The input voltage can be also entered by hand. In this case, use a voltmeter to measure the signal voltage at the sensor output or the signal input of the card. Note the measured voltage and enter it into the corresponding cell.
The newly created linearization point is displayed in the diagram to the right.
5. Repeat [Step 3](#) to [Step 4](#) until all rows are filled.
The current range of the corresponding current output and the online view are scaled on the defined static measuring range.

6.6.6 Digital inputs

Define the function of the five digital inputs. Assign the needed function to an arbitrary digital input or deactivate an input using the selection matrix shown in [Figure 6-25](#). To

control the bypass, limit multiplier, or operation mode function by software switches through the Modbus or OPC UA interface, select **Modbus/OPC UA** for the respective function.

Table 6-3: Software switches

Function	Modbus Holding register	OPC UA Command data point
Limit multiplier	Command.LimitMultiplier	LimitMultiplier
Bypass ¹	Command.Bypass	Bypass
Bypass DO 1-2	Command.BypassDO1To2	BypassDO1To2
Bypass DO 4-5	Command.BypassDO4To5	BypassDO4To5
Operation mode	Command.OperationMode	OperationMode

¹ Applications with calculation based on two channels

The typical reaction time for a software switch is approximately one second. The reaction time is the time between sending the command and the recognition of the command by the Universal Measurement Card. At a high input load, the reaction time might be higher.

Figure 6-25: Configuration of digital inputs

A6500-UM
Configuration - Draft

- Overview
- Basic
- Input 1
- Input 2
- Digital inputs
- Measurement 1
- Measurement 2
- Analysis 1
- Analysis 2
- Run-up/run-down 1
- Run-up/run-down 2
- Current output 1
- Current output 2
- Alarm limits 1
- Alarm limits 2
- Digital outputs

Digital inputs

Function	DI 1	DI 2	DI 3	DI 4	DI 5	Modbus/OPC UA	Off
Identify	<input type="radio"/>	<input type="radio"/>	<input type="radio"/>	<input type="radio"/>	<input type="radio"/>		<input checked="" type="radio"/>
Bypass DO 1-2	<input type="radio"/>	<input type="radio"/>	<input type="radio"/>	<input checked="" type="radio"/>	<input type="radio"/>	<input type="radio"/>	<input type="radio"/>
Bypass DO 4-5	<input type="radio"/>	<input type="radio"/>	<input type="radio"/>	<input type="radio"/>	<input checked="" type="radio"/>	<input type="radio"/>	<input type="radio"/>
Limit multiplier	<input type="radio"/>	<input type="radio"/>	<input type="radio"/>	<input type="radio"/>	<input type="radio"/>	<input type="radio"/>	<input checked="" type="radio"/>
Reset latch CH 1	<input type="radio"/>	<input type="radio"/>	<input type="radio"/>	<input type="radio"/>	<input type="radio"/>		<input checked="" type="radio"/>
Reset latch CH 2	<input type="radio"/>	<input type="radio"/>	<input type="radio"/>	<input type="radio"/>	<input type="radio"/>		<input checked="" type="radio"/>
Reset latch Channel OK 1	<input type="radio"/>	<input type="radio"/>	<input type="radio"/>	<input type="radio"/>	<input type="radio"/>		<input checked="" type="radio"/>
Reset latch Channel OK 2	<input type="radio"/>	<input type="radio"/>	<input type="radio"/>	<input type="radio"/>	<input type="radio"/>		<input checked="" type="radio"/>
Key 1	<input checked="" type="radio"/>						<input type="radio"/>
Key 2		<input type="radio"/>					<input checked="" type="radio"/>
Event trigger	<input type="checkbox"/>	<input type="checkbox"/>	<input type="checkbox"/>	<input type="checkbox"/>	<input type="checkbox"/>		<input checked="" type="checkbox"/>
Operation mode	<input type="checkbox"/>	<input type="checkbox"/>	<input checked="" type="checkbox"/>	<input checked="" type="checkbox"/>	<input type="checkbox"/>	<input type="checkbox"/>	<input type="checkbox"/>

Operation mode	DI 3	DI 4
Operation mode 1	<input type="radio"/>	<input type="radio"/>
Operation mode 2	<input checked="" type="radio"/>	<input type="radio"/>
Operation mode 3	<input type="radio"/>	<input checked="" type="radio"/>
Operation mode 4	<input checked="" type="radio"/>	<input checked="" type="radio"/>

Functions:

Identify Start a LED sequence on the front plate to identify the card in the rack. The sequence runs for approximately 15 seconds and stops automatically.

Bypass DO 1-2 For single channel applications. Disable digital outputs 1 and 2 of the card. The outputs are switched to their initial state. The initial state depends on the configured operation

principle (open- or closed-circuit mode) of the digital outputs. See [Bypass](#).

Whether the Channel OK (digital output 3) is affected or not depends on the setting of **Bypass affects** See [Input 1 and Input 2](#).

⚠ DANGER

These digital outputs are not part of the machine protection while Bypass is activated.

**Bypass DO
4-5**

For single channel applications.
Disable digital outputs 4 and 5 of the card. The outputs are switched to their initial state. The initial state depends on the configured operation principle (open- or closed-circuit mode) of the digital outputs. See [Bypass](#).

Whether the Channel OK of (digital output 6) is affected or not depends on the setting of **Bypass affects** See [Input 1 and Input 2](#).

⚠ DANGER

These digital outputs are not part of the machine protection while Bypass is activated.

Bypass

For double channel applications.
Disable the digital outputs. All outputs are switched to their initial state. The initial state depends on the configured operation principle (open- or closed-circuit mode) of the digital output. See [Bypass](#).

Whether the Channel OK is affected or not depends on the setting of **Bypass affects**. See [Input 1 and Input 2](#).

⚠ DANGER

There is no machine protection while Bypass is activated.

**Limit
multiplier**

Increase configured alarm limits. By activating, the alarm limits and a possibly configured hysteresis are multiplied by the defined factor. The factor is defined on configuration page **Alarm limits**. This function is recommended for dynamic measurements.

**Reset latch
CH 1**

Reset the latched alarms of channel 1. Reset alarms when the measurement value returns to the defined good range again – for example, below the alarm limit.

**Reset latch
CH 2**

Reset the latched alarms of channel 2. Reset alarms when the measurement value returns to the defined good range again – for example, below the alarm limit.

**Reset latch
Channel OK 1**

Reset the latched Channel not OK state of channel 1. The Channel not OK state can be reset as soon as the condition for Channel not OK (see [Channel OK supervision](#)) is no longer present.

Reset latch Channel OK 2	Reset the latched Channel not OK state of channel 2. The Channel not OK state can be reset as soon as the condition for Channel not OK (see Channel OK supervision) is no longer present.
Key 1 and Key 2	Configure the digital input for key-signal input. The key-signal 1 can only be assigned to digital input 1 and key-signal 2 only to digital input 2.
Event trigger	Select a digital input to trigger data capturing. Download the configuration to the A6500-UM card to use the selected trigger for the configuration of collection tasks (see operating manual AMS Machine Studio – General Functions for details).

Note

Digital inputs configured for key-signal input can not be used as an event trigger.

Operation mode	The operating modes configured on Basic (Basic) can be activated by digital inputs or by a software switch. Select one digital input to control two operating modes and two digital outputs to control three or four operating modes. Select Modbus to control the operating modes by software switches through the Modbus or OPC UA interface. After the selection, a table showing the required logical state of the selected digital inputs to activate a certain operating mode appears. See operating manual AMS Machine Studio – General Functions for the use of the Modbus and OPC UA interface. Alarm limit sets assigned to the activated operating mode also become active. See Alarm limits 1 and Alarm limits 2 .
-----------------------	--

6.6.7 Measurement 1 and Measurement 2

Define the data acquisition of the measurement (see [Figure 6-26](#)). In applications where the measurement value is calculated based on two channels, one **Measurement** page is available; otherwise, the measurement settings are available for both channels. Page **Measurement 1** is assigned to channel 1, and page **Measurement 2** is assigned to channel 2. The available parameters depend on the selected measurement application.

Figure 6-26: Measurement 1 and Measurement 2

Evaluation Available for dynamic measurements and static measurements with combined channels.
Select the signal evaluation form the list. The evaluation options depend on the selected measurement application and sensor. For more information see chapter [Applications](#).

Geometric factor Available for **Rod drop average mode** and **Rod drop triggered mode**.
Enter the geometrical factor depending on the machine geometric. See [Processing type "Rod Drop Average Mode"](#) or [Processing type "Rod Drop Triggered Mode"](#) for calculating this factor.

Note
The factor extends the measuring range. To use this range for further configuration send the configuration to the card before continuing.

Measuring range Available for dynamic measurements.
Enter the needed measuring range. The measuring range must be within the maximum permissible measuring range of the used sensor. The corresponding current output is scaled on this range. The online view is scaled accordingly.

Tacho Define the control of the measurement data acquisition. Choose between speed-controlled (option **Key**) or time-controlled (option **Time**).

- **Key 1 or Key 2**
Select **Key 1** if a key-signal is connected to digital input 1 or **Key 2** if a key-signal is connected to digital input 2.
The data acquisition is controlled using the connected key-signal. This setting is required for all analysis functions. The data acquisition automatically switches to time controlled in the following conditions:

- at a loss of the key-signal
- at a speed below the defined sub speed limit (see [Figure 6-32](#))
- at a speed above the defined over speed limit (see [Figure 6-32](#))

If the key-signal is available again or if the speed is again within the OK range (between sub speed limit and over speed limit), the control switches back to speed controlled.

- **Time**

Select **Time** if a key-signal is not connected or not needed for the measurement.

The data acquisition is controlled by the card. The analysis functions can not be used. Some optional parameters are not available. For dynamic measurements, a time window for the data acquisition can be defined. See [Optional parameter – measurement](#).

Begin and End

Available for static measurements with combined channels or eccentricity.

Enter the beginning and the end of the combined measurement range.

Shift

Available for static measurements or eccentricity.

Use this function to correct slight measuring deviations from the desired mechanical shaft zero position. Such deviations may occur after tightening the sensor. Enter the value different from zero for the shift or click **M** behind the entry field to measure the value different from zero.

1. Ensure that the shaft is at the mechanical zero position and there is an online connection to the AMS 6500 ATG.
2. Enter the displayed measuring value, in case of a negative deviation with sign or click **M** to measure the value.
3. Send the configuration to the A6500-UM.
The online display shows 0 mm.

Use the parameter **Shift affects the measuring range** to define the influence of the shift on measuring range and current output.

Shift affects the measuring range

Place a checkmark in the box to shift the measuring value and the measuring range. The current output is not affected as the measuring range is synchronously shifted with the measuring value. See [Figure 6-27](#).

Remove the checkmark from the box to shift the measuring value without shifting the measuring range. The current output is affected. Use this setting to correct small deviations caused by the mechanical sensor adjustment. See [Figure 6-28](#).

Figure 6-27: Shift example – measuring range affected

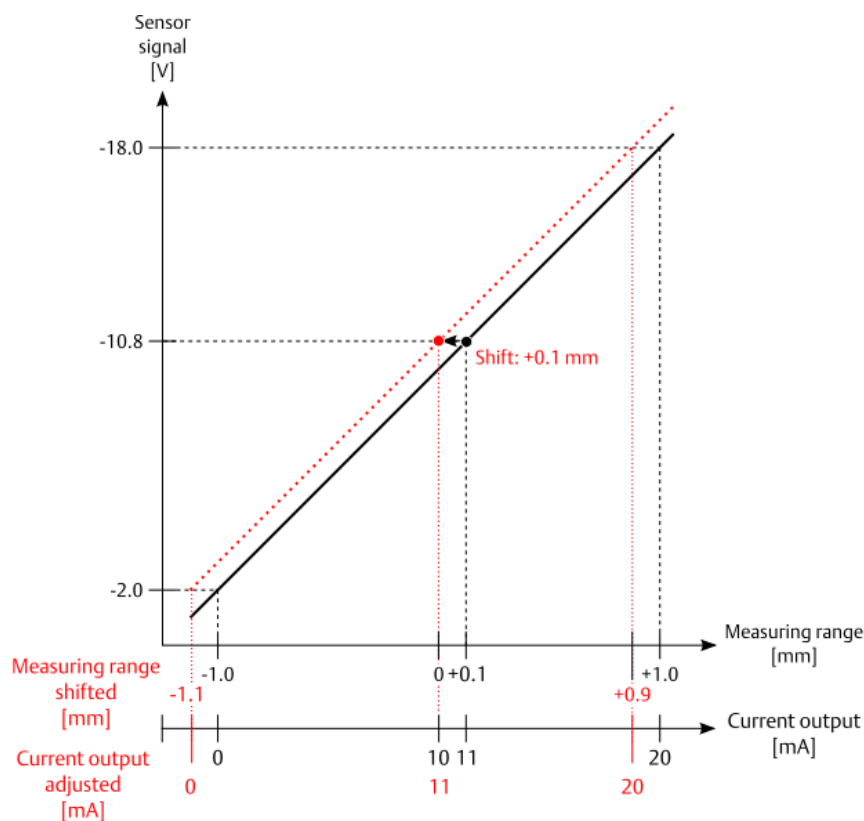

Shift example with 0.1 mm deviation from the desired zero position.

Before the shift:

- Online display in AMS Machine Studio shows 0.1 mm.
- Desired position 0.0 mm
- Measuring range is -1.0 to +1.0 mm.
- Current output shows 11 mA

After the shift of 0.1 mm:

- Online display in AMS Machine Studio shows 0.0 mm.
- Measuring range is shifted to -1.1 to +0.9 mm.
- Current output is adjusted to the measuring range shift. Current output still shows 11 mA.

Figure 6-28: Shift example - current output affected

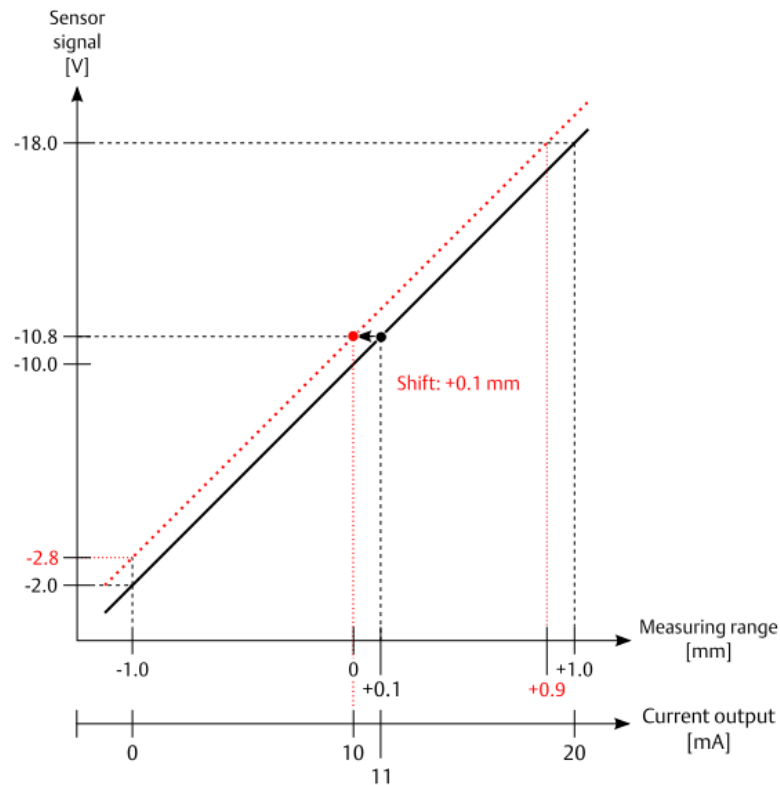

Shift example with 0.1 mm deviation from the desired zero position.

Before the shift:

- Online display in AMS Machine Studio shows 0.1 mm.
- Desired position 0.0 mm
- Measuring range is -1.0 to +1.0 mm.
- Current output shows 11 mA

After the shift of 0.1 mm:

- Online display in AMS Machine Studio shows 0.0 mm.
- Measuring range is still displayed as -1.0 to +1.0 mm.

Note

The measuring range are reduced by the shift value. The usable range is -1.0 to +0.9 mm

- Current output is set from 11 mA to 10 mA.

Note

After the shift, ensure that configured alarm limits are still within the usable measuring range.

Invert [mm]	<p>Available for static measurements.</p> <p>Place a checkmark in the box to invert the measuring range. The measurement value is calculated and output in an inverse proportion to the distance sensor – measurement object that means the greatest distance is defined as the measuring range beginning, and the smallest as the end of the measuring range. This inversion affects also the limit values, current outputs and the display of the measurement value in the online view.</p> <p>Signal inversion is useful, for example, at the measurement of the shaft expansion. Here the sensor can only be mounted in such a way that it measures in the negative direction although the positive direction is needed.</p>
Intersection point auto mode	<p>For static measurements with evaluation Tandem, not available for Tandem II.</p> <p>Place a checkmark in the box to activate the automatic detection of the intersection point. If this function has been activated, the card checks the sensor signal and sets the intersection point when the DC voltage of both sensor signals are equal. The function constantly checks the DC voltage and readjusts the intersection point if required.</p> <hr/> <p>Note</p> <p>Emerson recommends to deactivate the Intersection point auto mode after commissioning.</p> <hr/>
Intersection point [mm]	<p>For static measurements with evaluation Tandem, not available for Tandem II.</p> <p>Enter the intersection point if the automatic detection is not enabled. Click M behind the entry field to measure the intersection point or enter the value manually. For further information, see Measuring range definition.</p> <p>The currently active intersection point is shown in the Details tab of the online view (see Details).</p>
Ramp angle [°]	<p>Available for static measurements with cone evaluation.</p> <p>Enter the ramp angle of the cone used for the measurement. See Combined channel applications for description of measurements using a cone.</p>
Nominal speed [rpm]	<p>Available for all applications except Eccentricity.</p> <p>Enter the nominal speed of the machine. This parameter is only available with connected key-signal and selected Key 1 or Key 2 (see Figure 6-32).</p>
Piston angle	<p>Available for application Rod drop triggered mode and Cylinder pressure.</p> <p>Enter the piston angle, in the direction of rotation, to define the angle between key sensor and key mark when the piston is at top dead center (TDC).</p>

Figure 6-29: Definition piston angle

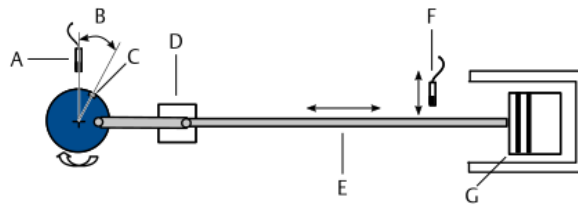

- A. Key sensor
- B. Piston angle
- C. Key mark
- D. Crosshead
- E. Piston rod
- F. Eddy current sensor for the rod drop measurement
- G. Piston

Trigger angular degree

Available for application **Rod drop triggered mode**.

Enter the trigger angle, in the direction of rotation, to define the trigger point for the measurement. The trigger angle is the angle between the top dead center and the position where you want to measure the rod drop. Find a point on the stroke where the influence of rod mechanical runout (crosshead-to-cylinder misalignment), rod deflection, and load changes are minimized. Emerson recommends to find this point through field testing during commissioning of the application "Rod drop triggered mode".

Note

Once the measurement has put into operation, do not change the configuration of the channel that provides the key-signal for the triggering. Changes to the key-signal may cause a trigger point deviation that affects the measuring accuracy.

Figure 6-30: Definition trigger angle

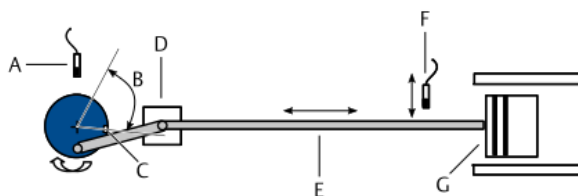

- A. Key sensor
- B. Trigger angle
- C. Key mark
- D. Crosshead
- E. Piston rod
- F. Eddy current sensor for the rod drop measurement
- G. Piston

**Sensor 1
damping**

Available for **Absolute shaft vibration**.

The damping factor will be entered automatically based on the selected bearing vibration sensor. If the sensor used for the measurement is not contained in the sensor library, or a higher calculation accuracy is required, enter the damping factor stated in the sensor's calibration report.

**Sensor 1
natural
frequency**

Available for **Absolute shaft vibration**.

The natural frequency will be entered automatically based on the selected bearing vibration sensor. If the sensor used for the measurement is not contained in the sensor library, or a higher calculation accuracy is required, enter the natural frequency stated in the sensor's calibration report.

Cylinder pressure

Define the cylinder pressure measurement. [Figure 6-31](#) provides an overview about a reciprocating compressor to help identifying the requested mechanical data.

Figure 6-31: Overview reciprocating compressor parts

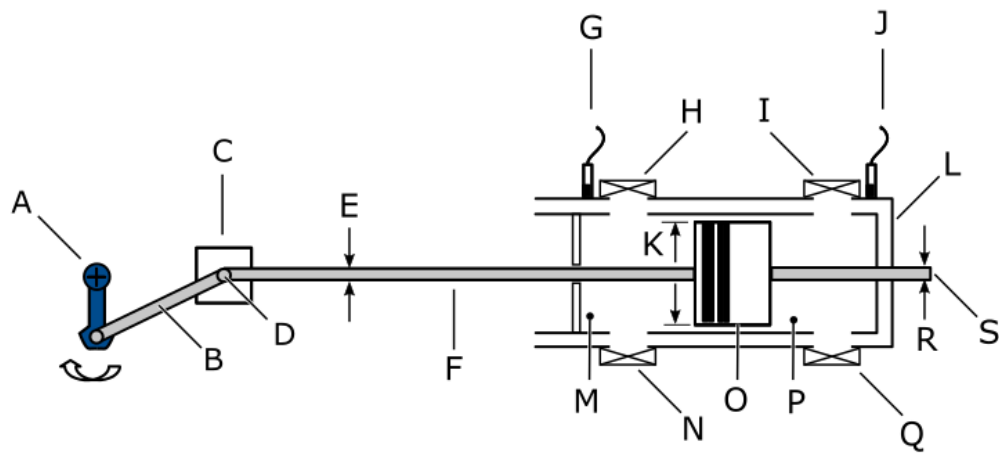

- A. Crank
- B. Connection rod
- C. Crosshead
- D. Crosshead pin
- E. Piston rod diameter (Rod diameter crank side)
- F. Piston rod
- G. Sensor crank side (chamber 1)
- H. Inlet chamber 1
- I. Inlet chamber 2
- J. Sensor head side (chamber 2)
- K. Piston diameter
- L. Cylinder
- M. Chamber 1
- N. Outlet crank side
- O. Piston
- P. Chamber 2
- Q. Outlet head side
- R. Tail rod diameter (Rod diameter head side, not always available)
- S. Piston rod head side (not always available)

Point Id	See Measurement 1 and Measurement 2 .
Evaluation	Select a signal evaluation. With the two channel calculation application Cylinder pressure the evaluations Discharge pressure , Suction pressure , Minimum/Maximum pressure , and Compression ratio can be selected per chamber.
Discharge pressure	Pressure inside the cylinder at top dead center position.
Suction pressure	Pressure inside the cylinder at bottom dead center position.

	Maximum pressure	Maximum pressure inside the cylinder over one cycle.
	Minimum pressure	Minimum pressure inside the cylinder over one cycle.
	Compression ratio	Ratio between Discharge pressure and Suction pressure .
	Peak rod compression	Peak combined rod load in compressing direction.
	Peak rod tension	Peak combined rod load in tension direction.
	Degree of rod reversal	Smallest distance between the points of zero force (combined rod load) represents the degrees of rod reversal.
Chamber		Select a chamber where the sensor is installed, if the compressor has more than one chamber. This parameter is available for single channel measurements. <ul style="list-style-type: none"> • Crank side (chamber 1) • Head side (chamber 2)
Input 1		Assign a chamber to input 1. Select the chamber where the sensor is installed that must be assigned to input 1. This parameter is available for the two channel application.
Input 2		The chamber that is not assigned to input 1 is automatically assigned to input 2. This parameter is available for the two channel application.
Measuring range		Enter the measuring range. The range is defined from 0 to the entered value. This range is used to scale the current output. Defined alarm limits must be within this range.
Piston angle		See Measurement 1 and Measurement 2 .
Tacho		See Measurement 1 and Measurement 2 .
Nominal speed		See Measurement 1 and Measurement 2 .
Stroke length		Enter the length of the crank.
Connection rod length		Enter the length of the connection rod.
Piston weight		Enter the weight of the piston.
Crosshead weight		Enter the weight of the cross head.
Piston diameter		Enter the diameter of the piston.
Piston rod diameter		Enter the diameter of the rod on the crank shaft side.

Tail rod diameter	Enter the diameter of the rod on the cylinder head side.
Ambient pressure	Enter the ambient pressure of the location where the compressor is installed.
Rod load	Select the position where the force is determined. <ul style="list-style-type: none">• At crosshead pin• At piston rod

Optional parameter – measurement

Click the down arrow in front of **Optional parameter** to open additional parameters for the data acquisition. The following parameters are available:

Use default setting	Select this option for usage of the default settings.
Use custom setting	Select this option to individually adjust the settings to the measuring task. To reset the settings to the default values click Reset to default .
Sub speed [rpm]	Available if Key 1 or Key 2 is selected, except eccentricity . Enter the lower speed limit which causes the measurement to switch from speed controlled to time controlled (see Figure 6-32).
Overspeed [rpm]	Available if Key 1 or Key 2 is selected, except eccentricity . Enter upper speed limit which causes the measurement to switch from speed controlled to time controlled (see Figure 6-32).
Speed tolerance [rpm]	Available if Key 1 or Key 2 is selected, except eccentricity . Use this field to define the stationary speed range for the data acquisition. <ul style="list-style-type: none">• Upper limit stationary range is the nominal speed plus the speed tolerance.• Lower limit stationary range is the nominal speed minus the speed tolerance.

[Figure 6-32](#) shows these ranges and limits

Figure 6-32: Diagram speed control ranges

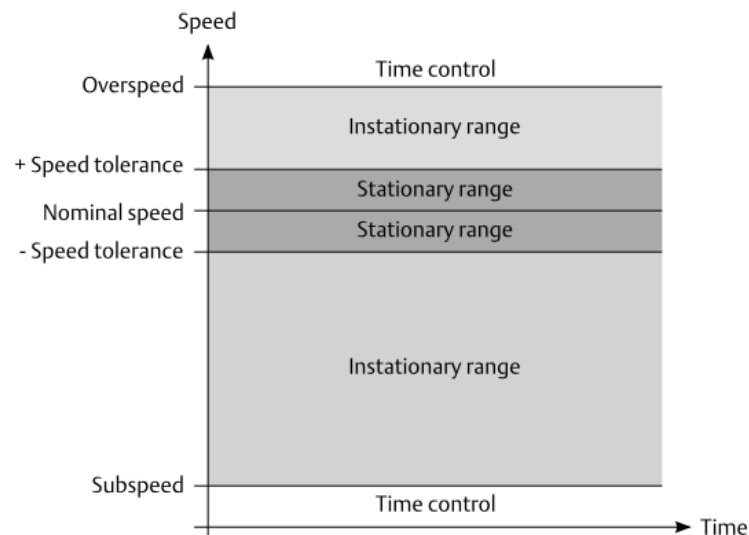

Rotations per cycle stationary	<p>Available if Key 1 or Key 2 is selected for dynamic measurements.</p> <p>Enter the number of shaft rotations per measurement cycle if the shaft speed is within the stationary range (see Figure 6-32). This parameter has an influence on the measurement cycle time. It defines how many rotations are used for the measurement and thereby the length of the measurement.</p>
Rotations per cycle instationary	<p>Available if Key 1 or Key 2 is selected for dynamic measurements.</p> <p>Enter the number of shaft rotations per measurement cycle if the shaft speed is within the instationary range (see Figure 6-32). To reduce the measurement cycle time at speeds below nominal speed, Emerson recommends entering only half of the number of rotations per cycle defined for the stationary range.</p>
Start speed [rpm]	<p>Available if Key 1 or Key 2 is selected for Eccentricity.</p> <p>Enter the beginning of the speed range for the eccentricity measurement. The lowest permissible value is 1 rpm.</p>
End speed [rpm]	<p>Available if Key 1 or Key 2 is selected for Eccentricity.</p> <p>Enter the end of the speed range for the eccentricity measurement. The measured eccentricity is valid as long as the detected speed is within the defined speed limits.</p>
Out of speed range suppression mode	<p>Available if Key 1 or Key 2 is selected for Eccentricity.</p> <p>Select a suppression mode to define the output behavior when the current speed is out of the speed range set by Start speed and End speed.</p> <ul style="list-style-type: none"> • [Evaluation¹] evaluation and current output

¹ Peak Peak, Minimum, or Maximum

The A6500-UM card behaves as follows when the speed is out of the configured range:

- The signal evaluation is stopped
- The measurement value is set to **0** if **Evaluation** → **Peak Peak** is selected or to the value entered for **Begin** if **Evaluation** → **Minimum** or **Maximum** is selected.
- The related data points of the Modbus interface, the OPC UA interface, and the measurement value displays are set to **0** if **Evaluation** → **Peak Peak** is selected or to the value entered for **Begin** if **Evaluation** → **Minimum** or **Maximum** is selected.
- The current output is set to the configured value (see Table 6-4).

Table 6-4: Current output value

Measurement value	Current output mode	Current output value
0 ¹ or value entered for Begin ²	0 to 20 mA	0 mA
	4 to 20 mA	4 mA
	20 to 4 mA	20 mA
	20 to 0 mA	20 mA

¹ *Evaluation* → *Peak Peak*

² *Evaluation* → *Minimum* or *Maximum*

As soon as the speed is within the defined range again, the suppression is deactivated.

- **[Evaluation²] evaluation alarms only**

The alarm outputs are switched to their initial state (no alarm) when the speed is out of the configured range. All other functions such as the current output or the display of the measured value are not affected.

As soon as the speed is within the defined range again, the suppression is deactivated.

Upper cutoff frequency [Hz] Enter the upper limit of the frequency range for the measurement. This value defines the -3 dB point of the low-pass filter. The permissible range for entering the upper cut off frequency depends on the select measurement application.

Lower cutoff frequency [Hz] Enter the lower limit of the frequency range for the measurement. This value defines the -3 dB point of the high-pass filter. The permissible range for entering the lower cut off frequency depends on the select measurement application.

Time window Available for dynamic measurement applications, if **Tacho** → **Time** is selectable.

² *Peak Peak, Minimum, or Maximum*

Select a time window to increase the update rate of the measurement. The selectable time windows depend on the selected measurement application and the configured evaluation. See [Table 6-5](#) for applications and evaluations for which time windows can be selected.

A higher update rate results in a shorter reaction time. See [Figure 6-33](#) for an example with a selected time window of 0.5 seconds at a default time window of 2.0 seconds.

Note

To avoid measurement fluctuations ensure that the selected time window fits to the entered **Lower cutoff frequency**. For example, the 0.5 seconds time window requires a minimum lower cutoff frequency of 2 Hz.

A warning note is issued if the selected time window does not fit to the lower cutoff frequency. Increase the lower cutoff frequency, except when the **Absolute shaft vibration** measurement application is used. There is no possibility to change the lower cutoff frequency. The **Absolute shaft vibration** warning note recommends to increase the time window.

Note

The default time window is used if the control automatically switches from speed controlled to time controlled due to exceeding the entered **Overspeed** limit or falling below the entered **Sub speed** limit. See [Table 6-5](#) for default values depending on the selection of measurement application and evaluation.

Table 6-5: Default value depending on measurement application

Measurement application		Evaluation(s)	Default value
Calculation based on two channels	Absolute shaft vibration	All	1.6 s
	Relative shaft vibration	All	2.0 s
	Relative shaft vibration – low frequency	All	5.0 s
	Absolute bearing vibration	Acceleration	1.0 s
		Velocity, Displacement, Voltage Input	2.0 s
	Absolute bearing vibration – low frequency	Acceleration	5.0 s
		Displacement, Voltage Input	5.5 s
Velocity		10.0 s	
Two separate channels	Relative shaft vibration	All	2.0 s

Table 6-5: Default value depending on measurement application
(continued)

Measurement application		Evaluation(s)	Default value
	Relative shaft vibration – low frequency	All	5.0 s
	Absolute bearing vibration	Acceleration, Voltage Input	1.0 s
		Velocity, Displacement	2.0 s
	Absolute bearing vibration – low frequency	Acceleration, Voltage Input	5.0 s
		Displacement	5.5 s
		Velocity	10.0 s
Dynamic pressure	All	1.0 s	
Vibration (low frequency) with order analysis	All	20.0 s	

Figure 6-33: Time window – example

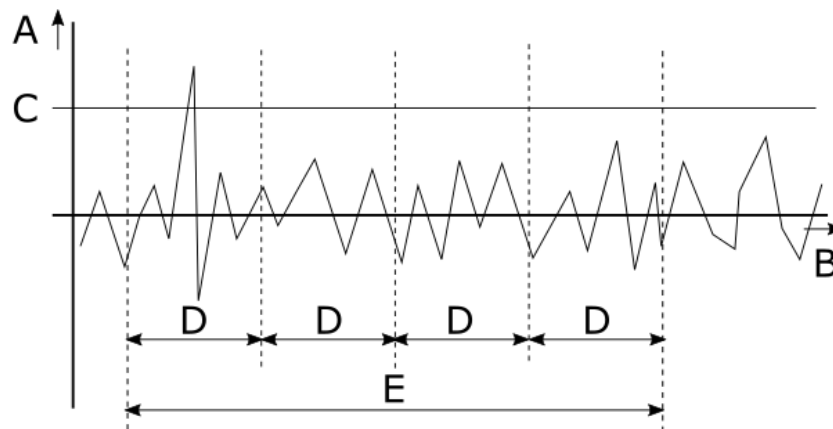

- A. Measurement value
- B. Time
- C. Limit value
- D. Selected **Time window** of 0.5 seconds
- E. Default **Time window** of 2.0 seconds

6.6.8 Analysis 1 and Analysis 2

These configuration pages are available for dynamic measurements (see [Figure 6-34](#)). Page **Analysis 1** is assigned to channel 1 and page **Analysis 2** is assigned to channel 2. The waveform signals of the single channels are analyzed at dynamic applications with calculations based on both channels.

Figure 6-34: Analysis 1 and Analysis 2

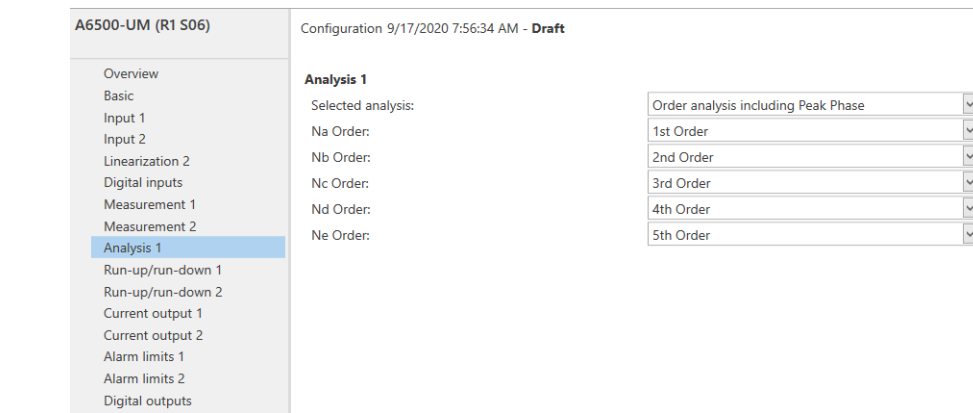

Selected analysis

Select the needed analysis option from the option list:

- **Inactive**
Select this option if no analysis is required.
- **Order analysis including PeakPhase**
Select this option if an order analysis is required. Define five orders (Na, Nb, Nc, Nd, and Ne) for the analysis through the corresponding list fields. One-third order, half order, or 1st to 20th order can be chosen. The order analysis is also necessary for Peak and Phase. Define alert and danger alarm limits for peak and phase on the **Alarm limits** page.
- **Band analysis (not available for application Vibration (low frequency) with order analysis)**
Select this option if band analysis is required. Up to eight frequency bands can be defined by limit input fields ... **frequency range min [Hz]** and ... **frequency range max [Hz]**. Define alert and danger alarm limits for the defined bands on the **Alarm limits** page.
The spectral part of the input signal with the highest amplitude is used for the processing.
- **PeakVue analysis (for absolute bearing vibration application)**
Select this option if PeakVue is required for this channel. Define alert and danger alarm limits for the PeakVue value on the **Alarm limits** page.
- **Interval band by frequency analysis (not available for application Vibration (low frequency) with order analysis)**

Select this option to measure the power spectral density within defined frequency bands. Up to eight frequency bands can be defined by limit input fields ... **frequency range min [Hz]** and ... **frequency range max [Hz]**. Define alert and danger alarm limits for the defined bands on the **Alarm limits** page.

Note

With AMS Machine Studio version 3.6, **Energy in band analysis** is renamed **Interval band by frequency analysis**.

- **Interval band by orders analysis** (not available for application **Vibration (low frequency) with order analysis**)

Select this option to measure the power spectral density within bands defined by orders. Up to eight bands can be defined by order selection lists ... **order range min** and ... **order range max**. Bands can be overlapping or consisting of only one order. Define alert and danger alarm limits for the defined bands on the **Alarm limits** page.

Note

A key-signal is required for **Interval band by orders analysis**.

Speed range min and Speed range max Enter a speed range for the interval band by orders analysis. The calculation is stopped if the measured speed is out of the configured speed range. An invalid analysis is indicated with the **Analysis** widget, see [Analysis](#).

- **Not 1st order analysis** (available for single channel applications)

Select this option to calculate the measuring value in peak-to-peak, 0-to-peak, or RMS evaluation based on the input signal without the 1st order in a speed range of 60 RPM to 18000 RPM.

The permissible speed range for **Not 1st order analysis** depends on the configured application.

Table 6-6: Permissible speed range

Application	Permissible speed range [rpm]
Absolute bearing vibration with acceleration measurement	600 to 18000
Absolute bearing vibration with velocity measurement	300 to 18000
Absolute bearing vibration (low frequency) with acceleration measurement	60 to 18000
Absolute bearing vibration (low frequency) with velocity measurement	60 to 18000
Relative shaft vibration	60 to 18000
Relative shaft vibration (low frequency)	60 to 18000

Note

A key-signal is required for **Not 1st order analysis**.

The calculation is stopped if the measured speed is out of the permissible speed range.

Integration

Integration Available:

- For the combined channel applications **Absolute bearing vibration** and **Absolute bearing vibration (low frequency)**
- For the two separate channels applications **Absolute bearing vibration** and **Absolute bearing vibration (low frequency)**
- If **Band analysis**, **Interval band by frequency analysis**, or **Interval band by orders analysis** is selected for **Selected analysis**
- If a sensor with acceleration units is selected (**Input** → **Sensor**)

Place a checkmark in the box to activate the integration of an acceleration input signal to a velocity signal used for the band analyses **Band analysis**, **Interval band by frequency analysis**, or **Interval band by orders analysis**.

Measuring range

Measuring range Available for **Band analysis**, **PeakVue analysis**, **Interval band by frequency analysis**, **Not 1st order analysis**, and **Interval band by orders analysis**.

Enter the measuring range for the selected analysis.

PeakVue analysis

The following additional parameters appear if **PeakVue analysis** is selected:

Select Filter Choose a filter to define a frequency range for the PeakVue analysis.

Show PeakVue Live Data Check this box to display the PeakVue time waveform instead of the general time waveform in the online view. With this box checked, the Modbus registers for the time data contain the PeakVue time waveform instead of the general time waveform.

See [PeakVue](#) for further information.

Not 1st order analysis

The following additional parameters appear if **Not 1st order analysis** is selected:

Evaluation Select the signal evaluation.

- **Peak-Peak**
The calculated value is proportional to the vibration signal in peak-to-peak evaluation.
- **Zero-Peak**
The calculated value is proportional to the vibration signal in 0-to-peak evaluation.
- **RMS**
The calculated value is proportional to the vibration signal in RMS³ evaluation.

- Acceleration mode** Select the acceleration mode to define the bandwidth for the filter.
- Select **Low** for machines with slowly changing machine speed. See [Table 6-7](#) for speed ranges and corresponding maximum accelerations. The suppression of the 1st order is more precise than the suppression with option **High** as the bandwidth is approximately 3 Hz.
 - Select **High** for machines with fast changing machine speed. See [Table 6-7](#) for speed ranges and corresponding maximum accelerations. The bandwidth is approximately 5 Hz.

Note

The calculated value of the **Not 1st order analysis** is valid for accelerations up to the maximum acceleration values (column **Acceleration [rpm/second]**) within the corresponding speed ranges (column **Speed range [rpm]**) listed in [Table 6-7](#).

Table 6-7: Speed ranges and corresponding maximum acceleration values

Acceleration mode	Speed range [rpm]	Acceleration [rpm/second]
Low	60 to 150	0.6
	150 to 360	2.4
	360 to 900	6.0
	900 to 1800	12.6
	1800 to 2700	22.2
	2700 to 3600	31.2
	3600 to 5400	43.8
	5400 to 7500	60.0
	7500 to 12000	90.0
	12000 to 18000	144.0
High	60 to 150	6.0
	150 to 360	24.0
	360 to 900	60.0
	900 to 1800	126.0
	1800 to 2700	222.0
	2700 to 3600	312.0
	3600 to 5400	438.0
	5400 to 7500	600.0
	7500 to 12000	900.0

Table 6-7: Speed ranges and corresponding maximum acceleration values (continued)

Acceleration mode	Speed range [rpm]	Acceleration [rpm/second]
	12000 to 18000	1440.0

6.6.9 Run-up / run-down 1 and Run-up / run-down 2

Define the recording of machine run-ups or run-downs (see [Figure 6-35](#)). Applications whereat the measurement value is calculated based on both channels, one **Run-up / run-down** page is available. Otherwise, the measurement settings are available for both channels. Page **Run-up / run-down 1** is assigned to channel 1 and page **Run-up / run-down 2** is assigned to channel 2. See [Recording of run-ups or run-downs](#) for a description of this function.

Figure 6-35: Run-up / Run-down

A6500-UM (R1 S06) Configuration 11/4/2020 11:41:52 AM - **Running**

Run-up/run-down 1

Enabled:

Speed limit min [RPM]:

Speed limit max [RPM]:

Overview
Basic
Input 1
Input 2
Linearization 2
Digital inputs
Measurement 1
Measurement 2
Analysis 1
Run-up/run-down 1
Run-up/run-down 2
Current output 1
Current output 2
Alarm limits 1
Alarm limits 2
Digital outputs

- Enabled** Place a checkmark in the box to activate the run-up or run-down recording.
- Speed limit min and Speed limit max** Enter the speed at which to start and stop the recording.

6.6.10 Current output 1 and Current output 2

Use the parameters on this page for the configuration of the current outputs (see [Figure 6-36](#)). At applications with two separate channels, **Current output 1** is assigned to the current output of channel 1 and **Current output 2** is assigned to the current output of channel 2. At applications with calculations based on both channels, both current outputs can be freely assigned to the calculated measuring value or to a single channel value. The available parameters depend on the selected measurement application.

Figure 6-36: Current output 1 and Current output 2

The screenshot shows the configuration page for 'Current output 1' in a device labeled 'A6500-UM (R1 S06)'. The page is titled 'Configuration - Draft'. On the left is a navigation menu with options like Overview, Basic, Input 1, Input 2, Digital inputs, Measurement, Analysis 1, Analysis 2, Run-up/run-down, Current output 1 (selected), Current output 2, Alarm limits 1, Alarm limits 2, and Digital outputs. The main content area is for 'Current output 1' and includes the following settings:

- Evaluation:** Displacement Smax (dropdown menu)
- Mode:** 4 - 20 mA (dropdown menu)
- Optional parameter (active):**
 - Use default setting
 - Use custom setting (with a 'Reset to default' button)
- Current suppression:**
- Current delay [s]:** 0 (text input)
- Range min. [µm]:** 0 (text input)
- Range max. [µm]:** 625 (text input)
- Break points:**
- Break point 1 value [%]:** 25 (text input)
- Break point 1 scale [%]:** 25 (text input)
- Break point 2 value [%]:** 75 (text input)
- Break point 2 scale [%]:** 75 (text input)

The selected current range is scaled on the defined measuring range (see [Current outputs](#)).

Evaluation Available for applications with calculation based on two channels. The selectable evaluations depend on the selected application and measurement. See [Table 6-8](#) to [Table 6-11](#) for details. The current output is assigned to the selection.

The listed selectable evaluations can be different when using a customized **Voltage input** as signal input.

Mode Select the required output current range:

- 0 to 20 mA
- 4 to 20 mA
Activation of the current suppression function is possible.
- 20 to 4 mA
Activation of the current suppression function is possible.
- 20 to 0 mA

By using the life zero range 4 to 20 mA, externally connected devices can be able to detect wire breaks or system failures. A drop of the output current below 4 mA indicates a malfunction or wire break.

Table 6-8: Overview evaluations – Relative shaft vibration

Relative Shaft Vibration and Relative Shaft Vibration (Low Frequency)	
Evaluation	Behavior
Displacement Smax or Smax P-P	The current output is assigned to the measuring value calculated from both channels.
CH 1 - Displacement 0-P	The current output is assigned to the 0-Peak displacement value of channel 1.

Table 6-8: Overview evaluations – Relative shaft vibration (continued)

Relative Shaft Vibration and Relative Shaft Vibration (Low Frequency)	
Evaluation	Behavior
CH 1 - Displacement P-P	The current output is assigned to the Peak-Peak displacement value of channel 1.
CH 1 - Displacement RMS	The current output is assigned to the RMS displacement value of channel 1.
CH 2 - Displacement 0-P	The current output is assigned to the 0-Peak displacement value of channel 2.
CH 2 - Displacement P-P	The current output is assigned to the Peak-Peak displacement value of channel 2.
CH 2 - Displacement RMS	The current output is assigned to the RMS displacement value of channel 2.
Off	The current output is switched off. The output is set to 0 mA.

Table 6-9: Overview evaluation – Absolute Shaft Vibration

Absolute Shaft Vibration	
Evaluation	Behavior
Displacement 0-P	The current output is assigned to the measuring value calculated from both channels.
CH 1 - Displacement 0-P	The current output is assigned to the 0-Peak displacement value of channel 1.
CH 2 - Displacement 0-P	The current output is assigned to the 0-Peak displacement value of channel 2.
Off	The current output is switched off. The output is set to 0 mA.

Table 6-10: Overview evaluations – Absolute bearing vibration

Absolute Bearing Vibration and Absolute Bearing Vibration (Low Frequency)			
Accelerometer		Velocity sensor	
Evaluation	Behavior	Evaluation	Behavior
Acceleration/Velocity Smax or Smax P-P	The current output is assigned to the measuring value calculated from both channels.	Velocity/Displacement Smax or Smax P-P	The current output is assigned to the measuring value calculated from both channels.
CH 1 - Acceleration/Velocity 0-P	The current output is assigned to the 0-Peak acceleration or velocity value of channel 1.	CH 1 - Velocity/Displacement 0-P	The current output is assigned to the 0-Peak velocity or displacement value of channel 1.

Table 6-10: Overview evaluations – Absolute bearing vibration (continued)

Absolute Bearing Vibration and Absolute Bearing Vibration (Low Frequency)			
Accelerometer		Velocity sensor	
Evaluation	Behavior	Evaluation	Behavior
CH 1 - Acceleration/ Velocity P-P	The current output is assigned to the Peak-Peak acceleration or velocity value of channel 1.	CH 1 - Velocity/ Displacement P-P	The current output is assigned to the Peak-Peak velocity or displacement value of channel 1.
CH 1 - Acceleration/ Velocity RMS	The current output is assigned to the RMS acceleration or velocity value of channel 1.	CH 1 - Velocity/ Displacement RMS	The current output is assigned to the RMS velocity or displacement value of channel 1.
CH 2 - Acceleration/ Velocity 0-P	The current output is assigned to the 0-Peak acceleration or velocity value of channel 2.	CH 2 - Velocity/ Displacement 0-P	The current output is assigned to the 0-Peak velocity or displacement value of channel 2.
CH 2 - Acceleration/ Velocity P-P	The current output is assigned to the Peak-Peak acceleration or velocity value of channel 2.	CH 2 - Velocity/ Displacement P-P	The current output is assigned to the Peak-Peak velocity or displacement value of channel 2.
CH 2 - Acceleration/ Velocity RMS	The current output is assigned to the RMS acceleration or velocity value of channel 2.	CH 2 - Velocity/ Displacement RMS	The current output is assigned to the RMS velocity or displacement value of channel 2.
Off	The current output is switched off. The output is set to 0 mA	Off	The current output is switched off. The output is set to 0 mA.

Table 6-11: Overview evaluations – Tandem/Cone

Tandem/Cone	
Evaluation	Behavior
Tandem, Cone 1, Cone 2, Double cone 1, Double cone 2, Addition, Subtraction, or Absolute difference	The current output is assigned to the measuring value calculated from both channels.
Min	The current output is assigned to the currently smallest measurement value out of both channels.
Max	The current output is assigned to the currently greatest measurement value out of both channels.
CH 1 - Displacement	The current output is assigned to the displacement value of channel 1.

Table 6-11: Overview evaluations – Tandem/Cone (continued)

Tandem/Cone	
Evaluation	Behavior
CH 2 - Displacement	The current output is assigned to the displacement value of channel 2.
Off	The current output is switched off. The output is set to 0 mA.

Optional parameter - current output

Click the down arrow in front of **Optional parameter** to open additional parameters for the current output.

- Use default setting** Select this option to use the default settings.
- Use custom setting** Select this option to individually adjust the settings to the measuring task.
 To reset the settings to the default values, click **Reset to default** behind this option.
- Current suppression** Available for ranges 4 to 20 mA and 20 to 4 mA.
 Place a checkmark in the box to activate the current suppression. The function is active if the box is marked. In case of a fault, the current is set to 0 mA.
- Current delay [s]** Enter a time between 0 and 20 seconds for easing the reaction of the output current. 0 seconds means no easing.
 The time causes a slow change in the current at fast changes of the measurement value. With a time of 20 seconds and a sudden change of the measurement value from 100% to 0% it will take approximately 20 seconds until the current has dropped by 63% (left diagram in [Figure 6-37](#)). The right diagram in [Figure 6-37](#) shows the change curve for a sudden change of the measurement value from 0 to 100%.

Figure 6-37: Diagram current output easing

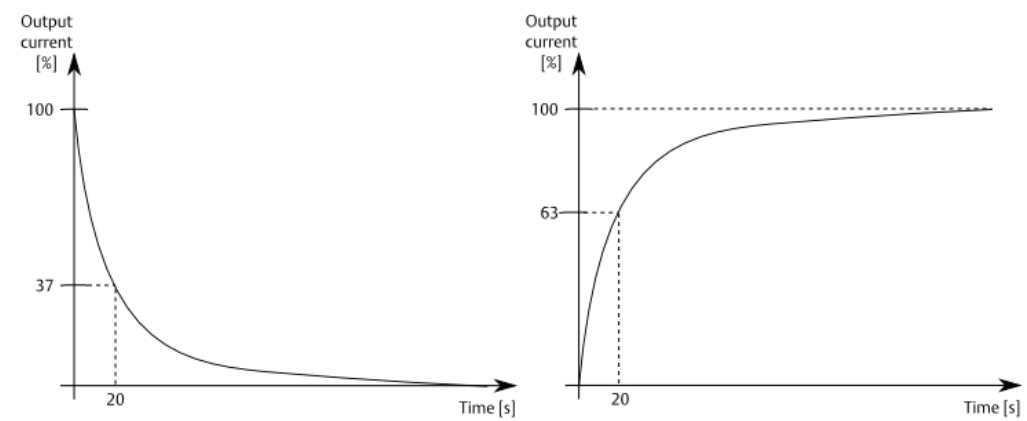

Range min. and Range max. Use these parameters for scaling the current output on a reduced measuring range. Enter the range minimum and range maximum of the needed measuring range.

Break points Use this function to divide the linear current output curve in an output curve with up to three linear parts with different gradients. Place a checkmark in the box to activate the break point function. After activation, four parameters for defining the break points appear:

- Break point 1 value [%]
- Break point 1 scale [%]
- Break point 2 value [%]
- Break point 2 scale [%]

The break points are defined in percent of the configured current output range and measuring range.

Figure 6-38 shows a break point example with a first break point at value 1 = 25% and scale 1 = 57% and the second break point at value 2 = scale 2 = 75%.

Figure 6-38: Example diagram break point

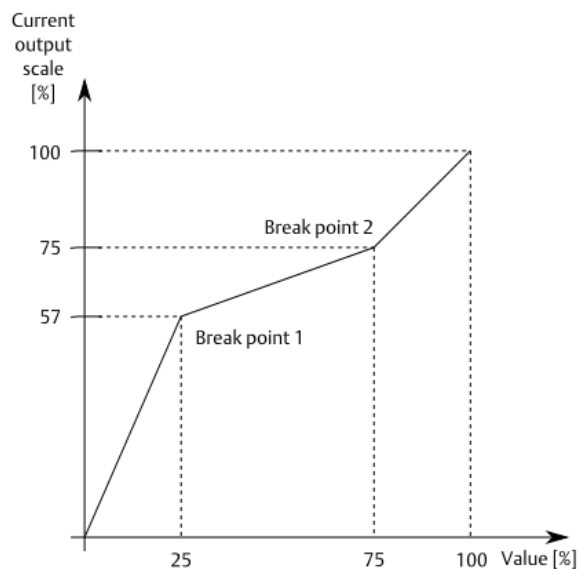

6.6.11 Alarm limits 1 and Alarm limits 2

Use the parameters on this page to configure the alarm limits (see Figure 6-39). Page **Alarm limits 1** is assigned to the alarm limits of channel 1 and page **Alarm limits 2** is assigned to the alarm limits of channel 2.

At applications with calculation based on both channels, the alarm limits of both pages are assigned to the calculated measuring value and not to a separate channel value. The alarms of **Alarm limits 2** are disabled by default to avoid an unintentional entering of different alarm limits for the same value.

The alarm status LED 1 is assigned to **Alarm limits 1** and the alarm status LED 2 is assigned to **Alarm limits 2**. The LEDs indicate the logical alarm state not the physical state of an assigned digital output. An assigned alarm status LED is on in case of a danger alarm and flashing in case of an alert alarm.

See [Digital outputs](#) for the assignment of the configured alarms to the digital outputs.

The unit within the square brackets behind the parameters depends on the configured measuring task and used sensors. The available parameters depend on the selected measurement application.

Figure 6-39: Alarm limits 1 and Alarm limits 2

<p>A6500-UM</p> <ul style="list-style-type: none"> Overview Basic Input 1 Input 2 Linearization 2 Digital inputs Measurement 1 Measurement 2 Analysis 1 Run-up/run-down 1 Run-up/run-down 2 Current output 1 Current output 2 Alarm limits 1 <li style="background-color: #e0e0e0;">Alarm limits 2 Digital outputs 	<p>Configuration - Draft</p> <p>Alarm limits 2</p> <p>^ Distance (active)</p> <p>Enabled: <input checked="" type="checkbox"/></p> <p>Upper danger alarm [mm]: <input type="text" value="1.2"/></p> <p>Upper alert alarm [mm]: <input type="text" value="0.4"/></p> <p>Lower alert alarm [mm]: <input type="text" value="-0.4"/></p> <p>Lower danger alarm [mm]: <input type="text" value="-1.2"/></p> <p>Alarm hysteresis [mm]: <input type="text" value="0"/></p> <p>Danger delay [s]: <input type="text" value="0"/></p> <p>Alert delay [s]: <input type="text" value="0"/></p> <p>Latching: <input type="checkbox"/></p> <p>Limit suppression: <input checked="" type="checkbox"/></p> <p>Limit multiplier: <input type="text" value="1"/></p> <p>∨ Gap voltage</p>
--	--

Alarm limits for different functions such as gap voltage supervision or analysis can be configured. Enabled alarm limits are marked with **(active)** behind the function.

Figure 6-40: Alarm limits for different functions

<p>A6500-UM (R1 S06)</p> <ul style="list-style-type: none"> Overview Basic Input 1 Input 2 Linearization 2 Digital inputs Measurement 1 	<p>Configuration 9/21/2020 11:28:34 AM - Draft</p> <p>Alarm limits 1</p> <ul style="list-style-type: none"> ∨ Displacement P-P (active) ∨ Gap voltage ∨ Not 1st order analysis (active)
--	--

Click the down arrow in front of the function name to open the parameters for entering the alarm limits.

Enable Place a checkmark in the box to enable the alarm limits.

Note

If **Enabled** is unchecked in a configuration with already configured alarm limits and then sent to the card, the configured alarm limits are lost. If the configuration of the alarm limits is then opened, the input fields

	<p>contain alarm limits that have been calculated on the basis of the input channel and the measurement configuration and might be different to the alarm limits entered before.</p> <hr/>
Evaluation	<p>Available for the application "Relative Shaft Position - Min/Max". Select the evaluation for the Min/Max application from the list.</p> <ul style="list-style-type: none"> • Min The alarm values are assigned to the currently smallest measurement value out of both channels. • Max The alarm values are assigned to the currently greatest measurement value out of both channels.
Upper danger alarm [unit] and Upper alert alarm [unit]	<p>Available for static measurements. Enter the upper danger alarm and upper alert alarm limit. The effective direction of these alarms is increasing, which means the alarm is triggered if the measurement value exceeds the defined limit.</p> <hr/> <p>Note The alert limit must be lower than the danger limit.</p> <hr/>
Lower alert alarm [unit] and Lower danger alarm [unit]	<p>Available for static measurements. Enter the lower alert alarm and lower danger alarm limit. The effective direction of these alarms is decreasing, which means the alarm is triggered if the measurement value falls below the defined limit.</p> <hr/> <p>Note The alert limit must be higher than the danger limit.</p> <hr/>
Danger alarm [unit] and Alert alarm [unit]	<p>Available for dynamic measurements. Enter the danger alarm and alert alarm limit. The effective direction of these alarms is increasing, which means the alarm is triggered if the measurement value exceeds the defined limit.</p> <hr/> <p>Note The alert limit must be lower than the danger limit.</p> <hr/>
Alarm limit sets	<p>Available for dynamic measurements. Up to four alarm limit sets consisting of danger alarm, alert alarm, and hysteresis can be used. Activate the configured alarm limits sets through digital inputs or through the Modbus or OPC UA interface (see Digital inputs).</p> <hr/> <p>Note The standard alarm limit set is available if None is selected for Basic → Operation modes.</p> <hr/> <p>Depending on the configuration, a table with up to four alarm limit sets is available.</p>

Figure 6-41: Alarm limit sets

Alarm limits 1

^ Displacement 0-P (active)

Enabled:

Alarm limit sets for operation modes:

#	Operation mode	Danger alarm	Alert alarm	Hysteresis	Unit
1	Operation mode 1 (default)	500	375	0	µm
2	Operation mode 2	525	425	0	µm
3	Operation mode 3	550	475	0	µm
4	Operation mode 4	575	525	0	µm

Danger delay [s]:

Alert delay [s]:

Latching:

Limit suppression:

Limit multiplier:

- Operation mode** Name of each alarm limit set. Change the name on page **Basic**.
- Danger alarm** Enter the danger alarm limit for each alarm limit set. The effective direction of this alarm is increasing, which means the alarm is triggered if the measurement value exceeds the defined limit.
- Alert alarm** Enter the alert alarm limit for each alarm limit set. The effective direction of this alarm is increasing, which means the alarm is triggered if the measurement value exceeds the defined limit.
- Hysteresis** Enter the alarm hysteresis for each alarm limit set. The hysteresis determines criteria for an alarm to be reset after a measurement value has exceeded a limit. See [Figure 6-42](#).

Note
An activated limit multiplier always affects the currently activated alarm limit set.

Alarm hysteresis [unit] Enter the alarm hysteresis. The hysteresis determines criteria for an alarm to be reset after a measurement value has exceeded a limit. This value refers to all alert and danger alarms configured on this page. The left diagram in [Figure 6-42](#) shows the behavior of a hysteresis at upper alarm limits of static measurements and alarm limits of dynamic measurements. The right diagram in [Figure 6-42](#) shows the hysteresis behavior at lower alarm limits of static measurements.

Figure 6-42: Hysteresis

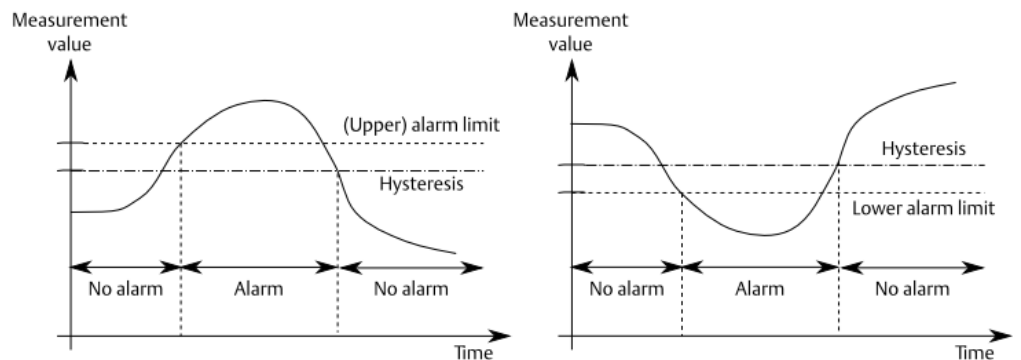

Danger delay [s] Define a trip delay for the danger alarm. The entered value is the time between the detection of the danger alarm status and the output of the alarm. The set value refers to the danger alarm.

Alert delay [s] Define a trip delay for the alert alarm. The entered value is the time between the detection of the alert alarm status and the output of the alarm. The set value refers to the alert alarm.

Note

If a configuration is opened, which was created with an older version of AMS Machine Studio containing only one delay for both alarms, then this delay is entered into both **Danger delay** and **Alert delay**.

Latching Activate this function to lock alarms. Locked alarms can be reset after a limit exceeding, when the measuring value is within the "No alarm" range again. A configured hysteresis is taken into account when defining the "No alarm" range. See [Figure 6-42](#). To reset the lock on alarms:

- In AMS Machine Studio, connect to this system and select **Reset latch** from the **Home** ribbon.
- Through the Modbus communication.
- By a digital input configured for reset latch.

Limit suppression Activate this function to suppress the alarm limits as soon as Channel OK is no longer present because of sensor failures. All other conditions (card malfunctions and activated bypass) that could lead to the suppression of the alarms remain unaffected by this parameter.

Note

Limit values suppressed means that the alarm outputs (digital outputs) are in their initial state (no "Alarm").

At single channel measurement and calculation of the measurement value, function limit value suppression is carried out depending on the status of the relevant channel. If the measurement value is calculated by combining both channels and monitored on limit value exceeding, only the error message of both channels will cause the alarm limit suppression.

Limit multiplier

Enter a value which will be multiplied with the configured alarm limits.

$$\text{Alarm limit}_{\text{raised}} = \text{Alarm limit} * \text{Limit multiplier}$$

This function raises the alarm limits of all alarms configured on this page. This input field is only used for defining the multiplier. The function is not active yet. Activate the limit multiplier through a digital input configured for this function.

Use this function, for example, to avoid false alarms during passing through critical speeds at machine run-up.

Alarm limits changed by an activated limit multiplier are also changed in the Modbus registers (**TV Danger Alarm** and **TV Alert Alarm**) and the online display (alarm limit indications on the bar graph assigned to the measurement value).

Note

When activated, a possibly configured hysteresis is also multiplied by the defined factor.

Limits for Peak and phase

The input fields for the alert alarm and danger alarm limits are available if **Order analysis** is selected for parameter **Selected analysis** on configuration page **Analysis**. See [Peak and Phase](#) for further description.

Click the down arrow in front of **Peak Phase** to open the alarm limit entry fields.

[Table 6-12](#) shows the default assignment of the peak and phase alarms to the digital outputs. For assignment to the digital outputs see [Digital outputs](#).

Table 6-12: Peak and Phase - Output assignment

Channel	Peak	Phase	Digital output
1	Peak danger alarm 1	Phase danger alarm 1	1
	Peak alert alarm 1	Phase alert alarm 1	2
	Peak danger alarm 2	Phase danger alarm 2	1
	Peak alert alarm 2	Phase alert alarm 2	2
	Channel OK		3
2	Peak danger alarm 1	Phase danger alarm 1	4
	Peak alert alarm 1	Phase alert alarm 1	5
	Peak danger alarm 2	Phase danger alarm 2	4
	Peak alert alarm 2	Phase alert alarm 2	5
	Channel OK		6

Enable

Place a checkmark in the box to enable the alarm limits.

Note

If **Enabled** is unchecked in a configuration with already configured alarm limits and then sent to the card, the configured alarm limits are lost. If the configuration of the alarm limits is then opened, the input fields contain alarm limits that have been calculated on the basis of the input channel and the measurement configuration and might be different to the alarm limits entered before.

Limit suppression	Activate this function to suppress the "Peak and Phase" alarm limits as soon as Channel Ok is no longer present because of sensor failures. All other conditions (card malfunctions, activated bypass, and so on) that could lead to the suppression of the alarms, remain unaffected by this parameter.
Order selection 1 and Order selection 2	Use this list field to select the order to be supervised. The selectable order depends on the settings of parameter Nx Order (x=a, b, c, d, and e) on configuration page Analysis .
Peak alert alarm 1 [μm] and Peak alert alarm 2 [μm]	Enter the limit value for the peak alert alarm. The effective direction of the alarm is increasing, which means that if the amplitude of the selected order (for example "Na") exceeds the limit value, the alarm will be triggered.
Peak danger alarm 1 [μm] and Peak danger alarm 2 [μm]	Enter the limit value for the peak danger alarm. The effective direction of the alarm is increasing, which means that if the amplitude of the selected order (for example "Na") exceeds the limit value, the alarm will be triggered.
Peak hysteresis 1 [μm] and Peak hysteresis 2 [μm]	Enter the hysteresis for the peak alert alarm and peak danger alarm. The hysteresis determines how much the measuring result must have fallen below the limit value after a limit value exceeding to reset the alarm.
Phase alert alarm 1 [$^{\circ}$] and Phase alert alarm 2 [$^{\circ}$]	Enter the limit value for the phase deviation alert alarm. The effective direction of the alarm is increasing, which means that if the positive or negative phase difference between the phase baseline and the actual measured phase of the selected order (for example "Na") is higher than the defined limit value, the alarm will be triggered.
Phase danger alarm 1 [$^{\circ}$] and Phase danger alarm 2 [$^{\circ}$]	Enter the limit value for the phase deviation danger alarm. The effective direction of the alarm is increasing, which means that if the positive or negative phase difference between the phase baseline and the actual measured phase of the selected order (for example "Na") is higher than the defined limit value, the alarm will be triggered.
Phase hysteresis 1 [$^{\circ}$] and Phase hysteresis 2 [$^{\circ}$]	Enter the hysteresis for the phase alert alarm and phase danger alarm. The hysteresis determines how much the phase difference must have fallen below the limit value after a limit value exceeding to reset the alarm.

Phase baseline 1 [°] and **Phase baseline 2 [°]** Automatically entered by the base line configuration tool (see [Peak and Phase](#)). The required value can also be entered manually. In this case, get the phase information of the baseline vector, for example, from an analysis system.

Limits for Band Analysis

The input fields for the band alert and danger limits are available, if **Band analysis** is selected for parameter **Selected analysis** on configuration page **Analysis**.

Click the down arrow in front of **Band Limits** to open the alarm limit entry fields.

[Table 6-13](#) shows the default assignment of the band alarms to the digital outputs. For assignment to the digital outputs see [Digital outputs](#).

Table 6-13: Band alarms - Output assignment

Channel	Band alarm	Digital output
1	Band 1 danger limit	1
	Band 1 alert limit	2
	Band 2 danger limit	1
	Band 2 alert limit	2
	Band 3 danger limit	1
	Band 3 alert limit	2
	Band 4 danger limit	1
	Band 4 alert limit	2
	Band 5 danger limit	1
	Band 5 alert limit	2
	Band 6 danger limit	1
	Band 6 alert limit	2
	Band 7 danger limit	1
	Band 7 alert limit	2
	Band 8 danger limit	1
	Band 8 alert limit	2
	Channel OK	3
2	Band 1 danger limit	4
	Band 1 alert limit	5
	Band 2 danger limit	4
	Band 2 alert limit	5
	Band 3 danger limit	4
	Band 3 alert limit	5
	Band 4 danger limit	4

Table 6-13: Band alarms - Output assignment (continued)

Channel	Band alarm	Digital output
	Band 4 alert limit	5
	Band 5 danger limit	4
	Band 5 alert limit	5
	Band 6 danger limit	4
	Band 6 alert limit	5
	Band 7 danger limit	4
	Band 7 alert limit	5
	Band 8 danger limit	4
	Band 8 alert limit	5
	Channel OK	6

Enable Place a checkmark in the box to enable the alarm limits.

Note

If **Enabled** is unchecked in a configuration with already configured alarm limits and then sent to the card, the configured alarm limits are lost. If the configuration of the alarm limits is then opened, the input fields contain alarm limits that have been calculated on the basis of the input channel and the measurement configuration and might be different to the alarm limits entered before.

Limit suppression Activate this function to suppress the "Band Limits" alarm limits as soon as Channel Ok is no longer present because of sensor failures. All other conditions (card malfunctions and activated bypass) that could lead to the suppression of the alarms remain unaffected by this parameter.

Band x alert limit (x = 1 to 8)
Enter the limit value for the band alert limit. The effective direction of the alarm is increasing, which means that if the measurement value within the selected band (for example "Band 1") exceeds the limit value, the alarm will be triggered.

Band x danger limit (x = 1 to 8)
Enter the limit value for the band danger limit. The effective direction of the alarm is increasing, which means that if the measurement value within the selected band (for example "Band 1") exceeds the limit value, the alarm will be triggered.

Limits for PeakVue analysis

The input fields for the PeakVue analysis alert and danger limits are available, if **PeakVue analysis** is selected for parameter **Selected analysis** on configuration page **Analysis**.

Click the down arrow in front of **PeakVue analysis** to open the alarm limit entry fields.

Enable	Place a checkmark in the box to enable the alarm limits.
	<p>Note</p> <p>If Enabled is unchecked in a configuration with already configured alarm limits and then sent to the card, the configured alarm limits are lost. If the configuration of the alarm limits is then opened, the input fields contain alarm limits that have been calculated on the basis of the input channel and the measurement configuration and might be different to the alarm limits entered before.</p>
Limit suppression	Activate this function to suppress the alarm limits as soon as Channel OK is no longer present because of sensor failures. All other conditions (card malfunctions and activated bypass) that could lead to the suppression of the alarms remain unaffected by this parameter.
Danger alarm	Enter the limit value for the PeakVue danger limit. The effective direction of the alarm is increasing, which means that if the measurement value exceeds the limit value, the alarm will be triggered.
Alert alarm	Enter the limit value for the PeakVue alert limit. The effective direction of the alarm is increasing, which means that if the measurement value exceeds the limit value, the alarm will be triggered.

Limits for Interval band by frequency analysis

The input fields for the interval band alert and danger limits are available, if **Interval band by frequency analysis** is selected for parameter **Selected analysis** on configuration page **Analysis**.

Click the down arrow in front of **Interval band by frequency analysis** to open the alarm limit entry fields.

[Table 6-14](#) shows the default assignment of the interval band alarms to the digital outputs. For assignment to the digital outputs see [Digital outputs](#).

Table 6-14: Interval band by frequency analysis alarms - Output assignment

Channel	Interval band by frequency analysis alarm	Digital output
1	Band 1 danger limit	1
	Band 1 alert limit	2
	Band 2 danger limit	1
	Band 2 alert limit	2
	Band 3 danger limit	1
	Band 3 alert limit	2
	Band 4 danger limit	1
	Band 4 alert limit	2
	Band 5 danger limit	1
	Band 5 alert limit	2

Table 6-14: Interval band by frequency analysis alarms - Output assignment
(continued)

Channel	Interval band by frequency analysis alarm	Digital output
	Band 6 danger limit	1
	Band 6 alert limit	2
	Band 7 danger limit	1
	Band 7 alert limit	2
	Band 8 danger limit	1
	Band 8 alert limit	2
	Channel OK	3
2	Band 1 danger limit	4
	Band 1 alert limit	5
	Band 2 danger limit	4
	Band 2 alert limit	5
	Band 3 danger limit	4
	Band 3 alert limit	5
	Band 4 danger limit	4
	Band 4 alert limit	5
	Band 5 danger limit	4
	Band 5 alert limit	5
	Band 6 danger limit	4
	Band 6 alert limit	5
	Band 7 danger limit	4
	Band 7 alert limit	5
	Band 8 danger limit	4
	Band 8 alert limit	5
	Channel OK	6

Enable

Place a checkmark in the box to enable the alarm limits.

Note

If **Enabled** is unchecked in a configuration with already configured alarm limits and then sent to the card, the configured alarm limits are lost. If the configuration of the alarm limits is then opened, the input fields contain alarm limits that have been calculated on the basis of the input channel and the measurement configuration and might be different to the alarm limits entered before.

Limit suppression	Activate this function to suppress the alarm limits as soon as Channel OK is no longer present because of sensor failures. All other conditions (card malfunctions and activated bypass) that could lead to the suppression of the alarms remain unaffected by this parameter.
Band x alert limit	(x = 1 to 8) Enter the limit value for the interval band alert limit. The effective direction of the alarm is increasing, which means that if the measurement value within the selected band (for example "Band 1") exceeds the limit value, the alarm will be triggered.
Band x danger limit	(x = 1 to 8) Enter the limit value for the interval band danger limit. The effective direction of the alarm is increasing, which means that if the measurement value within the selected band (for example "Band 1") exceeds the limit value, the alarm will be triggered.

Limits for Interval band by orders analysis

The input fields for the **Interval band by orders analysis** alert and danger limits are available if **Analysis** → **Select analysis** → **Interval band by orders analysis** is selected.

Click the down arrow in front of **Interval band by orders analysis** to open the alarm limit entry fields.

[Table 6-15](#) shows the default assignment of the **Interval band by orders analysis** alarms to the digital outputs. For assignment of the digital outputs see [Digital outputs](#).

Table 6-15: Interval band by orders analysis alarms – output assignment

Channel	Interval band by orders alarm	Digital output
1	Order band 1 danger limit	1
	Order band 1 alert limit	2
	Order band 2 danger limit	1
	Order band 2 alert limit	2
	Order band 3 danger limit	1
	Order band 3 alert limit	2
	Order band 4 danger limit	1
	Order band 4 alert limit	2
	Order band 5 danger limit	1
	Order band 5 alert limit	2
	Order band 6 danger limit	1
	Order band 6 alert limit	2
	Order band 7 danger limit	1
	Order band 7 alert limit	2
	Order band 8 danger limit	1

Table 6-15: Interval band by orders analysis alarms – output assignment (continued)

Channel	Interval band by orders alarm	Digital output
	Order band 8 alert limit	2
	Channel OK	3
2	Order band 1 danger limit	4
	Order band 1 alert limit	5
	Order band 2 danger limit	4
	Order band 2 alert limit	5
	Order band 3 danger limit	4
	Order band 3 alert limit	5
	Order band 4 danger limit	4
	Order band 4 alert limit	5
	Order band 5 danger limit	4
	Order band 5 alert limit	5
	Order band 6 danger limit	4
	Order band 6 alert limit	5
	Order band 7 danger limit	4
	Order band 7 alert limit	5
	Order band 8 danger limit	4
	Order band 8 alert limit	5
	Channel OK	6

Enable Place a checkmark in the box to enable the alarm limits.

Note

If **Enabled** is unchecked in a configuration with already configured alarm limits and then sent to the card, the configured alarm limits are lost. If the configuration of the alarm limits is then opened, the input fields contain alarm limits that have been calculated on the basis of the input channel and the measurement configuration and might be different to the alarm limits entered before.

Limit suppression Activate this function to suppress the alarm limits as soon as Channel OK is no longer present because of sensor failures or the measured speed is out of the defined speed range (see [Speed range min and Speed range max](#)). All other conditions (card malfunctions and activated bypass) that could lead to the suppression of the alarms remain unaffected by this parameter.

Band x danger limit (x = 1 to 8)
Enter the limit value for the band danger limit. The effective direction of the alarm is increasing, which means that the alarm is triggered if the

	measurement value within the selected band (for example "Band 1") exceeds the limit value.
Band x alert limit	(x = 1 to 8) Enter the limit value for the alert limit. The effective direction of the alarm is increasing, which means that the alarm is triggered if the measurement value within the selected band (for example "Band 1") exceeds the limit value.

Limits for Not 1st order analysis

The input fields for alert and danger limits are available if **Analysis** → **Select analysis** → **Not 1st order analysis** is selected.

Click the down arrow in front of **Not 1st order analysis** to open the alarm limit entry fields. For assignment to the digital outputs see [Digital outputs](#).

Enable	Place a checkmark in the box to enable the alarm limits.
---------------	--

Note

If **Enabled** is unchecked in a configuration with already configured alarm limits and then sent to the card, the configured alarm limits are lost. If the configuration of the alarm limits is then opened, the input fields contain alarm limits that have been calculated on the basis of the input channel and the measurement configuration and might be different to the alarm limits entered before.

Limit suppression	Activate this function to suppress the alarm limits as soon as Channel OK is no longer present because of sensor failures. All other conditions (card malfunctions and activated bypass) that could lead to the suppression of the alarms remain unaffected by this parameter.
Danger alarm	Enter the danger alarm limit. The effective direction of this alarm is increasing, which means the alarm is triggered if the measurement value exceeds the defined limit.
Alert alarm	Enter the alert alarm limit. The effective direction of this alarm is increasing, which means the alarm is triggered if the measurement value exceeds the defined limit.

Gap voltage

The input fields for the alert alarm and danger alarm limits are available for channels with a connected eddy current measuring chain. Click the down arrow in front of **Gap voltage** to open the alarm limit entry fields.

For assignment to the digital outputs, see [Digital outputs](#).

Use the gap voltage limits to supervise the DC part of the sensor signal of an eddy current measuring chain. The DC part is proportional to the distance between the measuring object such as a machine shaft and the eddy current sensor.

With vibration measurements, use the gap voltage supervision to get a notification when the eddy current sensor gets loose or the machine shaft moves more as expected in radial direction.

Figure 6-44: Gap voltage example – distance static signal

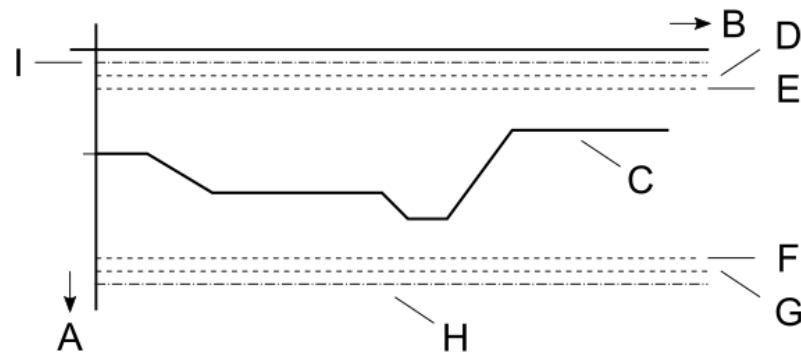

- A. Sensor voltage
- B. Time
- C. DC part of the sensor signal (distance static signal)
- D. Upper gap voltage danger alarm
- E. Upper gap voltage alert alarm
- F. Lower gap voltage alert alarm
- G. Lower gap voltage danger alarm
- H. Lower Channel OK limit
- I. Upper Channel OK limit

Enable

Place a checkmark in the box to enable the alarm limits.

Note

If **Enabled** is unchecked in a configuration with already configured alarm limits and then sent to the card, the configured alarm limits are lost. If the configuration of the alarm limits is then opened, the input fields contain alarm limits that have been calculated on the basis of the input channel and the measurement configuration and might be different to the alarm limits entered before.

Upper gap voltage danger alarm

Enter the upper danger alarm limit. The effective direction of this alarm is increasing, which means the alarm is triggered if the measurement value exceeds the defined limit.

Upper gap voltage alert alarm

Enter the upper alert alarm limit. The effective direction of this alarm is increasing, which means the alarm is triggered if the measurement value exceeds the defined limit.

Note

The upper alert limit must be lower than the upper danger limit.

Lower gap voltage alert alarm

Enter the lower alert alarm limit. The effective direction of this alarm is decreasing, which means the alarm is triggered if the measurement value falls below the defined limit.

Note

The lower alert limit must be higher than the lower danger limit.

Lower gap voltage danger alarm Enter the lower danger alarm limit. The effective direction of this alarm is decreasing, which means the alarm is triggered if the measurement value falls below the defined limit.

Alarm hysteresis Enter an alarm hysteresis. The hysteresis determines criteria for an alarm to be reset after a measurement value has exceeded a limit. The entry applies to all four limits defined above. See [Figure 6-42](#).

6.6.12 Digital outputs

Assign limits configured on the pages **Alarm limits 1** and **Alarm limits 2** to the digital outputs.

Figure 6-45: Digital output

A6500-UM (R1 S06)		Configuration 11/4/2020 11:41:52 AM - Running			
Overview		Digital outputs			
Name	Description	Type	Sources (OR)	Circuit mode	
DO 1	Danger	Danger	<input checked="" type="checkbox"/> CH 1 - Displacement 0-P <input type="checkbox"/> CH 2 - Distance	Normally open	
DO 2	Alert	Alert	<input checked="" type="checkbox"/> CH 1 - Displacement 0-P <input type="checkbox"/> CH 2 - Distance	Normally open	
DO 3	COK	Channel OK	CH 1 - OK		
DO 4	Danger	Danger	<input type="checkbox"/> CH 1 - Displacement 0-P <input checked="" type="checkbox"/> CH 2 - Distance	Normally open	
DO 5	Alert	Alert	<input type="checkbox"/> CH 1 - Displacement 0-P <input checked="" type="checkbox"/> CH 2 - Distance	Normally open	
DO 6	COK	Channel OK	CH 2 - OK		

Name Name of the digital output.

Description Enter a description for the digital output or use the default entry.

Type Indicates the type of the digital output.

Sources (OR) Assign a source to the digital output. Place a checkmark in the box next to source to select it. The available sources depend on the selected measurement application and the configuration of the alarm limits ([Alarm limits 1](#) and [Alarm limits 2](#)). All sources, selected for one digital output, are in OR combination. That means that the digital output switches if the defined limit of at least one of the assigned sources is exceeded.

Circuit mode Select the operating principle of the digital output.

- **Normally open**
With activated alarms, the output is conductive and an externally connected relay is activated.
- **Normally closed**
With activated alarms, the output is disabled and an externally connected relay is deactivated.

6.6.13 Speed

This chapter describes the parameters of the configuration for the speed and redundant speed application. Only the configuration pages **Digital inputs**, **Measurement 1**, **Measurement 2**, **Current output 1**, **Current output 2**, and **Digital outputs** are described. For description of the other configuration pages see chapters [Overview](#), [Basic](#), and [Input 1 and Input 2](#).

Note

A6500-UM cards with hardware revision 08 or later do not accept a speed configuration created for an A6500-UM card with a hardware revision 07 or earlier. Create a new speed configuration for A6500-UM cards with hardware revision 08 or later.

Speed - Digital inputs

Define the function of the five digital inputs. Assign the needed function to an arbitrary digital input or deactivate an input by the selection matrix shown in [Figure 6-46](#). To control the bypass by software switches through the Modbus or OPC UA interface select **Modbus** for the respective bypass.

Table 6-16: Software switches – Speed

Function	Modbus register	OPC UA data point
Bypass DO 1-2 or Bypass ¹	SWI 2	SW_INPUT_2
Bypass DO 4-5	SWI 3	SW_INPUT_3

¹ Application: Redundant speed

The typical reaction time for a software switch is approximately one second. The reaction time is the time between sending the command and the recognition of the command by the Universal Measurement Card. At a high input load, the reaction time might be higher.

Figure 6-46: Configuration of digital inputs – speed application

Function	DI 1	DI 2	DI 3	DI 4	DI 5	Modbus	Off
Identify	<input type="radio"/>	<input type="radio"/>	<input type="radio"/>	<input type="radio"/>	<input type="radio"/>		<input checked="" type="radio"/>
Bypass DO 1-2	<input type="radio"/>	<input checked="" type="radio"/>	<input type="radio"/>	<input type="radio"/>	<input type="radio"/>	<input type="radio"/>	<input type="radio"/>
Bypass DO 4-5	<input type="radio"/>	<input type="radio"/>	<input checked="" type="radio"/>	<input type="radio"/>	<input type="radio"/>	<input type="radio"/>	<input type="radio"/>
Reset min/max channel 1	<input type="radio"/>	<input type="radio"/>	<input type="radio"/>	<input type="radio"/>	<input type="radio"/>		<input checked="" type="radio"/>
Reset min/max channel 2	<input type="radio"/>	<input type="radio"/>	<input type="radio"/>	<input type="radio"/>	<input type="radio"/>		<input checked="" type="radio"/>
Reset rotation direction	<input type="radio"/>	<input type="radio"/>	<input type="radio"/>	<input type="radio"/>	<input checked="" type="radio"/>		<input type="radio"/>
Activate test value 1	<input type="radio"/>	<input type="radio"/>	<input type="radio"/>	<input checked="" type="radio"/>	<input type="radio"/>		<input type="radio"/>
Activate test value 2	<input checked="" type="radio"/>	<input type="radio"/>	<input type="radio"/>	<input type="radio"/>	<input type="radio"/>		<input type="radio"/>
Reset latch DO 1	<input type="radio"/>	<input type="radio"/>	<input checked="" type="radio"/>	<input type="radio"/>	<input type="radio"/>		<input type="radio"/>
Reset latch DO 2	<input type="radio"/>	<input type="radio"/>	<input checked="" type="radio"/>	<input type="radio"/>	<input type="radio"/>		<input type="radio"/>
Reset latch DO 4	<input type="radio"/>	<input type="radio"/>	<input checked="" type="radio"/>	<input type="radio"/>	<input type="radio"/>		<input type="radio"/>
Reset latch DO 5	<input type="radio"/>	<input type="radio"/>	<input checked="" type="radio"/>	<input type="radio"/>	<input type="radio"/>		<input type="radio"/>
Event trigger	<input type="radio"/>	<input type="radio"/>	<input type="radio"/>	<input type="radio"/>	<input checked="" type="radio"/>		<input type="radio"/>

Functions:

Identify

Starts a LED sequence on the front plate to identify the card in the rack. The sequence runs for approximately 15 seconds and stops automatically.

Bypass

Redundant speed application.

Disable the digital outputs. All outputs are switched to their initial state. The initial state depends on the configured operation principle (open- or closed-circuit mode) of the digital outputs. See [Bypass](#).

Whether the Channel OK is affected or not depends on the setting of **Bypass**. See [Speed - Digital outputs](#).

⚠ DANGER

There is no machine protection while activated.

Bypass DO 1-2

Single speed channel application.

Disable digital outputs 1 and 2 of the card. The outputs are switched to their initial state. The initial state depends on the configured operation principle (open- or closed-circuit mode) of the digital outputs. See [Bypass](#).

Whether the Channel OK (digital output 3) is affected or not depends on the setting of **Bypass**. See [Input 1 and Input 2](#).

⚠ DANGER

These digital outputs are not part of the machine protection while Bypass is activated.

Bypass DO 4-5

Single speed channel application.

Disable digital outputs 4 and 5 of the card. The outputs are switched to their initial state. The initial state depends on the configured operation principle (open- or closed-circuit mode) of the digital outputs. See [Bypass](#).

Whether the Channel OK (digital output 6) is affected or not depends on the setting of **Bypass**. See [Input 1 and Input 2](#).

⚠ DANGER

These digital outputs are not part of the machine protection while Bypass is activated.

Reset min/max measurement 1

Reset of the minimum and maximum speed value measured by channel 1.

Reset min/max measurement 2

Reset of the minimum and maximum speed value measured by channel 2.

Reset rotation direction

Reset of the detected rotational direction.

Activate test value 1	Activation of the configured test value for channel 1. The test value is configured on page Measurement 1 .
Activate test value 2	Activation of the configured test value for channel 2. The test value is configured on page Measurement 2 .
Reset latch DO 1	Reset of latched alarms of digital output 1. ⁴
Reset latch DO 2	Reset of latched alarms of digital output 2 ⁴ .
Reset latch DO 4	Reset of latched alarms of digital output 4 ⁴ .
Reset latch DO 5	Reset of latched alarms of digital output 5 ⁴ .
Event trigger	Digital inputs can be used to trigger data capturing. Place a checkmark in the box to activate triggering for the associated digital input. Download the configuration to the A6500-UM card to use the trigger for the configuration of collection tasks (see operating manual AMS Machine Studio - General Functions for details).

Speed - Measurement 1 and Measurement 2

Define the data acquisition of the measurement (see [Figure 6-47](#)). Page **Measurement 1** is assigned to channel 1 and page **Measurement 2** is assigned to channel 2.

⁴ The requirement for resetting of alarms is that the measurement value is back in the defined good range again – for example, below the alarm limit.

Figure 6-47: Measurement 1 and Measurement 2 - speed application

A6500-UM (R1 S01)		Configuration 7/10/2017 10:41:45 AM - Running		
<ul style="list-style-type: none"> Basic Input 1 Input 2 Digital inputs Measurement 1 Measurement 2 Current output 1 Current output 2 Digital outputs 	Measurement 1			
	Channel off:	<input type="checkbox"/>		
	Measure mode:	<input type="text" value="n times per rotation"/>	▼	
	Glitch suppression:	<input checked="" type="checkbox"/>		
	Maximum speed [RPM]:	<input type="text" value="3500"/>		
	Symmetry [%]:	<input type="text" value="50"/>		
	Input mode:	<input type="text" value="Dynamic (fast)"/>	▼	
	Upper trigger threshold limit [V]:	<input type="text" value="-13"/>	Set	
	Lower trigger threshold limit [V]:	<input type="text" value="-15"/>		
	Offset tracking:	<input type="checkbox"/>		
	Number of teeth:	<input type="text" value="1"/>		
	^ Optional parameter (active)			
		<input type="radio"/> Use default setting		
		<input checked="" type="radio"/> Use custom setting	<input type="button" value="Reset to default"/>	
	Input edge:	<input type="text" value="positive edge"/>	▼	
	Averaging:	<input checked="" type="checkbox"/>		
	Gap threshold limit [V]:	<input type="text" value="-1.8"/>		
	Acceleration damping time [s]:	<input type="text" value="0.1"/>		
	Standstill time [s]:	<input type="text" value="10"/>		
	Transmission ratio numerator:	<input type="text" value="1"/>		
	Transmission ratio denominator:	<input type="text" value="1"/>		
	Preferred rotation direction:	<input type="text" value="normal"/>	▼	
	Reset rotation direction:	<input type="text" value="low"/>	▼	
	Pulse out:	<input checked="" type="checkbox"/>		
	Advanced synchronization:	<input checked="" type="checkbox"/>		
Pulse out function:	<input type="text" value="n times per rotation"/>	▼		
Pulse out inversion:	<input type="text" value="normal"/>	▼		
Display range minimum (speed) [RPM]:	<input type="text" value="0"/>			
Display range maximum (speed) [RPM]:	<input type="text" value="3500"/>			
Display range minimum (acceleration) [RPM/s]:	<input type="text" value="-10000"/>			
Display range maximum (acceleration) [RPM/s]:	<input type="text" value="10000"/>			
Activate test value:	<input checked="" type="checkbox"/>			
Test value target:	<input type="text" value="Speed"/>	▼		
Test value [RPM]:	<input type="text" value="3000"/>			
Timeout [s]:	<input type="text" value="10"/>			
Affect current out:	<input type="checkbox"/>			

Channel off Place a checkmark in the box to deactivate the channel. The channel is not used if the box is marked.

Measure mode Select the measuring mode from the list field. The following options are available:

- **once per rotation**
The measurements of one or more complete shaft revolution are arithmetically averaged and output as measurement value. So the refresh time of the measurement value corresponds to the time for the complete shaft revolutions (example for one revolution: 20 ms at 3000 rpm).

- **n times per rotation**

The refresh time depends on the selected input mode **Dynamic** or **Static** and on the actual speed. At input mode **Dynamic**, the measuring result is refreshed every 5 to 10 ms. At input mode **Static**, the measuring result is refreshed every 104 to 216 ms. An advantage of this partial gear measuring mode is the short refresh time of ≤ 10 ms than 20 ms (at 3000 rpm) in measuring mode **once per rotation**. A disadvantage of the partial gear measuring mode is a possibly more unstable indication of the measurement value. This is caused by varying measuring results during a rotation because of shaft vibrations and mechanical deviations of tooth gaps and sizes. At higher speeds, the measure mode is automatically switched to **once per rotation**.

- **n times per rotation variable**

The refresh time depends on the nominal speed. The refresh time is between the duration of one shaft rotation at nominal speed and twice this time.

Example: At a nominal speed of 3000 rpm, the refresh time is 20 ms. Depending on the current speed, the measuring result will be refreshed every 20 to 40 ms. Consequently, at nominal speed the measurement value will be refreshed approximately once per rotation.

An advantage compared to the mode “once per rotation” is that at slow speeds the maximum refresh time is at max twice the duration of a shaft rotation at nominal speed. Disadvantage compared to the measurement method **n times per rotation** is the higher refresh time.

At higher speeds, the measure mode is automatically switched to **once per rotation**.

Glitch suppression

Place a checkmark in the box to activate the glitch suppression (general input filter). It suppresses signal disturbances which could cause faulty speed detection.

Maximum speed [RPM]

Enter the maximum machine speed.

Symmetry [%]

Enter the pulse width ratio of the input signal. This parameter is required, and is used together with the maximum speed (parameter **Maximum speed [rpm]**) for adjusting the noise pulse filter. The filter has the widest passband at a symmetry setting of 1%.

Define the pulse width ratio with the pulse output (key-signal output).

Note

Ensure that **n times per rotation** has been chosen for Parameter **n times per rotation** otherwise the pulse signal is not tooth synchronous.

1. Measure the pulse output signal at arbitrary speeds with an oscilloscope at the key-signal output of the used channel (channel 1: XRx1.6 and channel 2: XRx2.6; GND: select one of the GNDs of

the slot (for example: XR_x1.GND - see also A6500-xR System Racks operation manual).

Emerson recommends checking the pulse width ratio at nominal speed and adjusting it if necessary as the pulse width at nominal speed is crucial for the noise pulse filter.

2. Calculate the symmetry. Use the period portion which is smaller than 50% for the definition of the symmetry as the entry range of the parameter is limited to 1 to 50%. This could be either pulse width or pulse pause (see [Figure 6-48](#)).

$$\text{Symmetry} = \frac{\text{Period portion}_{\leq 50\%} * 100\%}{\text{Pulse width} + \text{Pulse pause}}$$

Example with Period portion_{≤50%} (Pulse width) = 4 ms and Pulse width + Pulse pause (period duration) = 20 ms:

$$\text{Symmetry} = \frac{4 \text{ ms} * 100\%}{20 \text{ ms}} = 20\%$$

3. Enter the calculated symmetry.

Note

Permissible tolerance: -20% of the entered symmetry value. Wider respectively longer pulses cause higher symmetry values than the entered symmetry value. These pulses are not filtered. Smaller respectively shorter pulses cause symmetry values lower than the entered value. Pulses with a symmetry value below the entered value minus 20% may be identified as noise pulses.

Example: With an entered symmetry of 20%, the actual symmetry may not be below 16%, measured at the pulse output, at nominal speed. All pulses with a symmetry above the limit of 16% are used for speed calculation respectively detection of rotational direction. Pulses below this limit of 16% may be identified as noise pulses and then filtered out. Above this limit, the symmetry of the input signal may vary.

Figure 6-48: Diagram symmetry - pulse output

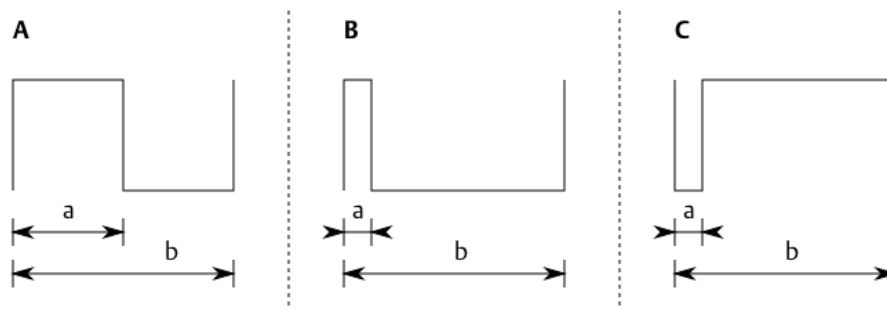

- A. Symmetry 50%
Pulse width (a) = Pulse pause (b-a)
 $b = \text{Pulse width} + \text{Pulse pause}$
- B. Symmetry 20%
 $a = \text{Period portion} < 50\%$
 $b = \text{Pulse width} + \text{Pulse pause}$
- C. Symmetry 20%
 $a = \text{Period portion} < 50\%$
 $b = \text{Pulse width} + \text{Pulse pause}$
The symmetry value based always on the period portion <50%.

- At machine standstill, determine the expected pulse width ratio by means of the trigger wheel dimensions. The symmetry declaration is based either on the tooth width or on the gap width depending on which width is less than 50% related to the pitch.

Calculate the symmetry with the following formula. [Figure 6-49](#) and [Figure 6-50](#) show symmetry examples based on a trigger wheel with rectangular tooth profile and with chamfered flanks.

Tooth width $\leq 50\%$:

$$\text{Symmetry} = \frac{\text{Tooth width}_{\leq 50\%} * 100\%}{\text{Tooth width}_{\leq 50\%} + \text{Gap width}}$$

Gap width $\leq 50\%$:

$$\text{Symmetry} = \frac{\text{Gap width}_{\leq 50\%} * 100\%}{\text{Gap width}_{\leq 50\%} + \text{Tooth width}}$$

Example with Tooth width $\leq 50\% = 9 \text{ mm}$ and Tooth width + Gap width = 45 mm:

$$\text{Symmetry} = \frac{9 \text{ mm} * 100\%}{45 \text{ mm}} = 20\%$$

Note

The symmetry should be set to 1% if the calculated symmetry is less than 10%. The noise pulse filter has the widest passband at this setting. This is valid, independently if the symmetry has been calculated by means of the pulse output signal or based on the trigger wheel dimensions.

2. Check a symmetry calculated with trigger wheel dimensions with an oscilloscope at running machine by means of the pulse output.
-

Figure 6-49: Diagram symmetry - trigger wheel with rectangular tooth profile

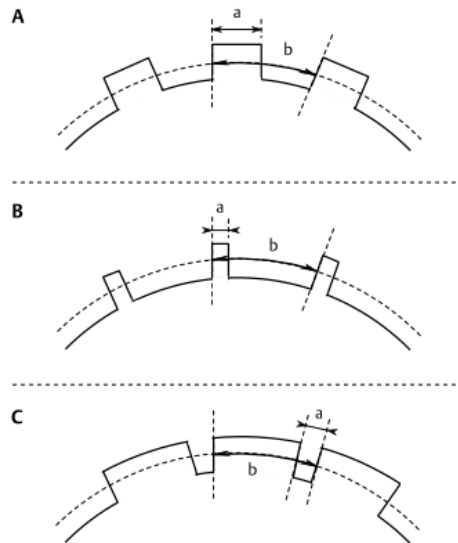

- A. Symmetry 50%
Tooth width (a) = Gap width (b-a)
 $b = \text{Tooth width} + \text{Gap width}$
 - B. Symmetry 20%
Tooth width (a) < Gap width (b-a)
 $b = \text{Tooth width} + \text{Gap width}$
 - C. Symmetry 20%
Gap width (a) < Tooth width (b-a)
 $b = \text{Tooth width} + \text{Gap width}$
-

Figure 6-50: Diagram symmetry - trigger wheel with chamfered flanks

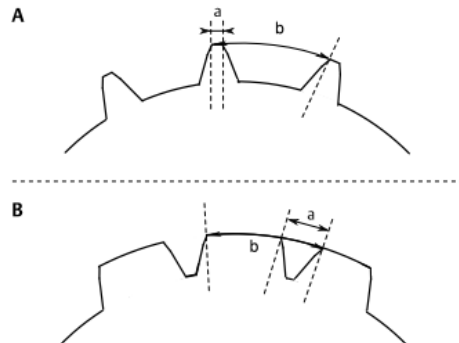

- A. Symmetry 10%
Tooth width (a) < Gap width (b-a)
b = Tooth width + Gap width
- B. Symmetry 30%
Gap width (a) < Tooth width (b-a)
b = Tooth width + Gap width

When using a key mark, calculate the symmetry with the following formula from the shaft radius and the width of the notch or key-mark (see [Figure 6-51](#)).

Figure 6-51: Shaft with key-mark

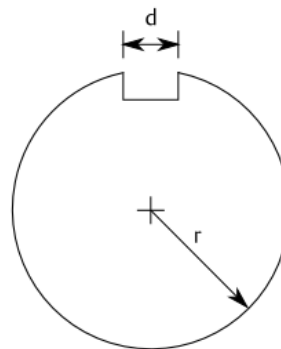

r = shaft radius

d = width of the key-mark

$$\text{Symmetry} = \frac{d}{2 * r * \pi} * 100\%$$

Example with shaft radius = 125 mm and width of the key-mark = 16 mm:

$$\text{Symmetry} = \frac{16 \text{ mm}}{2 * 125 \text{ mm} * \pi} * 100\% = 2.04\%$$

Round the result down to the next smaller number as only integer values can be entered.

Input mode	Choose the input mode. <ul style="list-style-type: none">• Static (slow) High reaction time, maximum 500 ms. The advantage of this mode are adjustable trigger thresholds (levels).• Dynamic (fast) Short reaction time, maximum 30 ms. In this mode, the card works with fixed trigger thresholds that can not be changed. Ensure that the input signal amplitude is never lower than 6.0 V, otherwise the measurement will not work.
Upper trigger threshold limit [V] and Lower trigger threshold limit [V]	Enter the upper and lower threshold limits for detection of the signal pulses from the trigger wheel or trigger mark. These entry fields are only active if Static (slow) is chosen for "Input mode". The limits can be manually defined or automatically detected by clicking Set .

Note
Set is disabled if a Hall-effect sensor is selected (**Input** → **Sensor**)

For details see [Trigger threshold limit detection](#). [Figure 6-52](#) shows an example signal of an eddy current measuring chain with an output voltage range of -2 to -18 V.

Figure 6-52: Speed- example sensor signal with limits

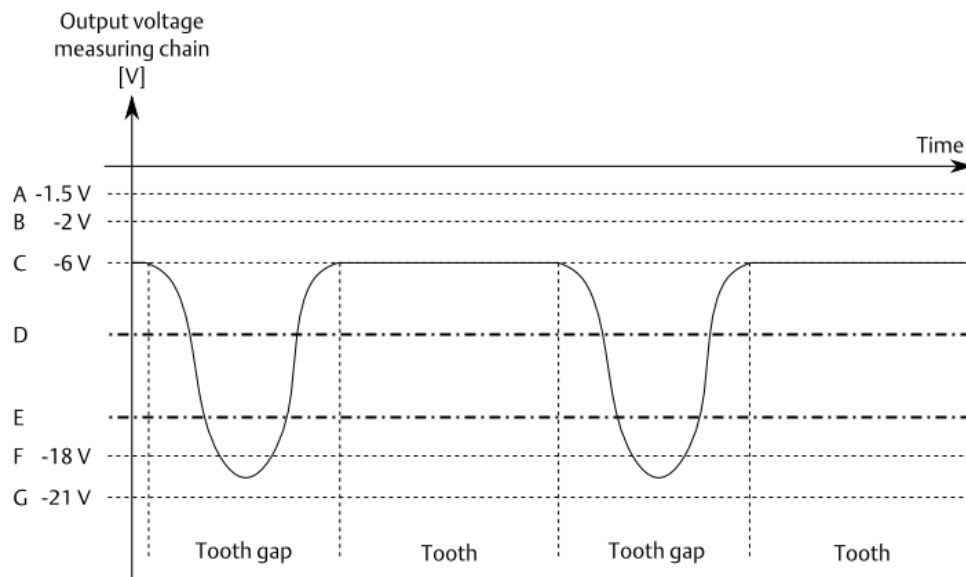

- A. Upper channel OK limit
- B. Gap threshold limit and initial value linear range
- C. Sensor adjustment voltage
- D. Upper trigger threshold limit
- E. Lower trigger threshold limit
- F. End value linear range
- G. Maximum output voltage (non linear range)

Offset tracking Check this box to activate the function "Offset tracking".

Note

Offset tracking has no function if **Dynamic (fast)** is selected for parameter **Input mode**.

Function "Offset tracking" allows the trigger thresholds to adapt depending on changes of the DC signal component caused by, for example, radial shaft displacements. Figure 6-53 shows the principle of this tracking function. Until the time X, the trigger threshold limits are within the range of the input signal. As of time X, the DC component of the input signal increases on the level marked with "C" and as a consequence the signal will leave range of the trigger thresholds "B". Now, a detection of input pulses would not be possible. With the activated offset tracking, the trigger thresholds will be adapted corresponding to the change of the input signal "D".

Figure 6-53: Offset tracking

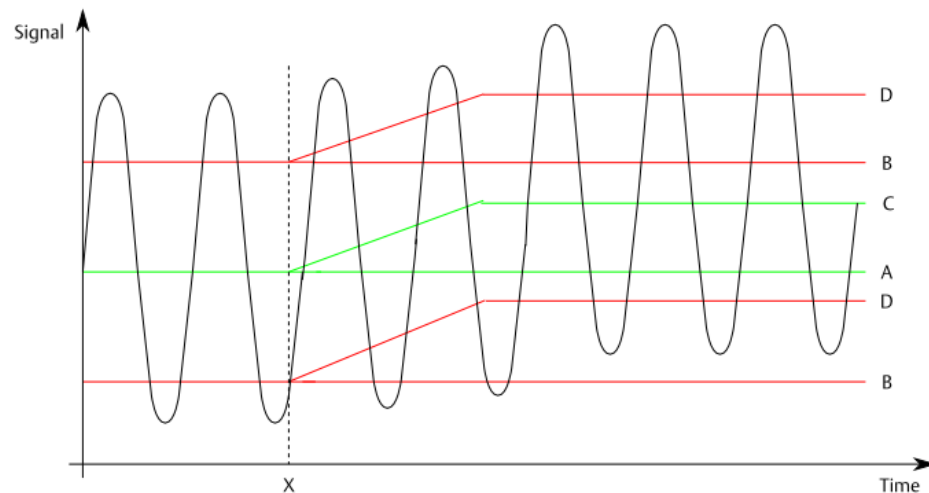

Number of teeth Enter the number of teeth of the trigger wheel. If only one trigger mark (groove or tooth) is available, enter "1". This parameter is used together with the signal frequency for calculating the speed.

Optional parameter - speed measurement

Click the down arrow in front of **Optional parameter** to show additional parameters for the measurement configuration.

Use default setting Select this option to use the default settings.

Use custom setting Select this option to individually adjust the settings to the measuring task.

To reset the settings to the default values, click **Reset to default**.

Input edge Choose the trigger point for the input signal from the selection list.

- Positive edge
- Negative edge

The trigger point defines the start point of the pulse detection on input signal. This parameter can be used to compensate signal disturbances like jitter effects on the input signal. If there is, for example, a jitter on the positive edge of the sensor input signal, choose **Negative edge** to compensate. Changing from positive to negative edge causes an inversion of the pulse output signal (key-signal). Use the parameter **Pulse out inversion** if the inversion must be compensated.

Averaging Place a checkmark in the box to activate the easing of the calculated speed. This function does not affect the reaction time of the measurement. Emerson recommends activating the averaging.

Gap threshold limit [V]	<p>Enter the gap threshold limit. This parameter serves the supervision of the minimal distance between eddy current measuring chain and measuring target (tooth, shaft surface or key mark). Define a gap threshold limit equal to the initial value of the measuring chain output voltage range. When falling below this limit value, a gap warning will be output.</p> <p>Example: If the initial voltage is -2 V enter a gap threshold limit of approximately -2 V (see Figure 6-52).</p> <p>When the gap limit is exceeded again, after it was under run before, the gap warning will be canceled.</p> <p>No function if Hall-effect sensors (for example: PR 9376) are used.</p>
Acceleration damping time [s]	<p>Use this parameter for easing the acceleration value. Enter a damping time in the range 0 to 5 seconds. "0" means no damping. Because of the short measuring time, the indications of acceleration values may vary. The damping time defines the value that it takes for the system to reach 63 % of the asymptotic end value. After a delay of 5 x Acceleration damping time the asymptotic end value will be reached. This parameter influences current outputs assigned to the acceleration value and digital outputs assigned to function "Acceleration". For stable measurements enter a time constants >0.1 second and select for parameter Measure mode, once per rotation.</p>
Standstill time [s]	<p>The standstill time defines how many seconds have to elapse after the last pulse was detected at the signal input before standstill is indicated. The configured standstill time must be longer than the time between two measured pulses with the machine running. Message "Standstill" will be reset as soon as the next pulse is detected at the signal input.</p>
Transmission ratio numerator and Transmission ratio denominator	<p>If a gear is used, enter the corresponding gear transmission ratio as numerator and denominator. Enter the numerator of the gear ratio in Transmission ratio numerator and the denominator in Transmission ratio denominator. For a gear ratio of 1:1, set both parameters to 1. These parameters are related to the calculated speed and thus also to the current output.</p> <hr/> <p>Note The entered transmission ratio has no influence on the key-signal.</p> <hr/>
Preferred rotation direction	<p>Use this list field to define the indication of the detected rotation direction.</p> <ul style="list-style-type: none">• normal• inverse <p>The arrangement of the sensors at the trigger wheel determines which of the rotation directions is considered by the monitor to be "normal" and which one as "inverse". If the normal rotation direction does not correspond to the indication of the nominal direction, the indication can be inverted by choosing inverse. For</p>

sensor arrangement, see chapter [Radial arrangement of the sensors](#).

Reset rotation direction

Use this list field to define the logical state of a digital output assigned to the function "Rotational direction" after a reset of the detected rotation direction or at machine standstill.

- **low**
Function output in initial state.
- **high**
Function output activated.

When the shaft starts turning again the rotation direction will be shown according to the detected direction.

Pulse out

Place a checkmark in the box to activate the pulse output (key signal) for this channel.

Advanced synchronization

Place a checkmark in the box to activate the key signal generation for the advanced synchronization. This key signal contains one extended pulse within one second of the key signal (see [Figure 6-54](#)). This extended pulse is used for the advanced synchronization of the data collection (see [AMS Machine Studio - General Functions operating manual](#)).

Note

A key signal with extended pulses can not be generated if:

- The parameter **Number of teeth** is set to a value greater than 1 and the parameter **Pulse out function** is set to **once per rotation**.
- The parameter **Pulse out inversion** is set to **inverse**.

Check the online view **Details** on the availability of the advanced synchronization.

Figure 6-54: Key signal with extended pulses

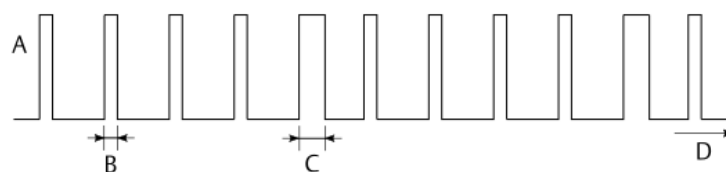

- A. Key signal
- B. Pulse with constant duration, approximately 120 μ s
- C. Extended pulse (once within one second)
- D. Time

Pulse out function

Use this list field to define the type of the output pulse.

- **once per rotation**

One output pulse per shaft rotation, independently if a toothed trigger wheel, a single tooth, or key-mark is used for the measurement.

- **n times per rotation**

One output pulse per detected tooth (tooth synchronous).

Pulse out inversion Use this parameter to invert the output pulse. [Figure 6-55](#) shows the function of this parameter. Select between **normal** and **inverse**.

Figure 6-55: Pulse output inversion

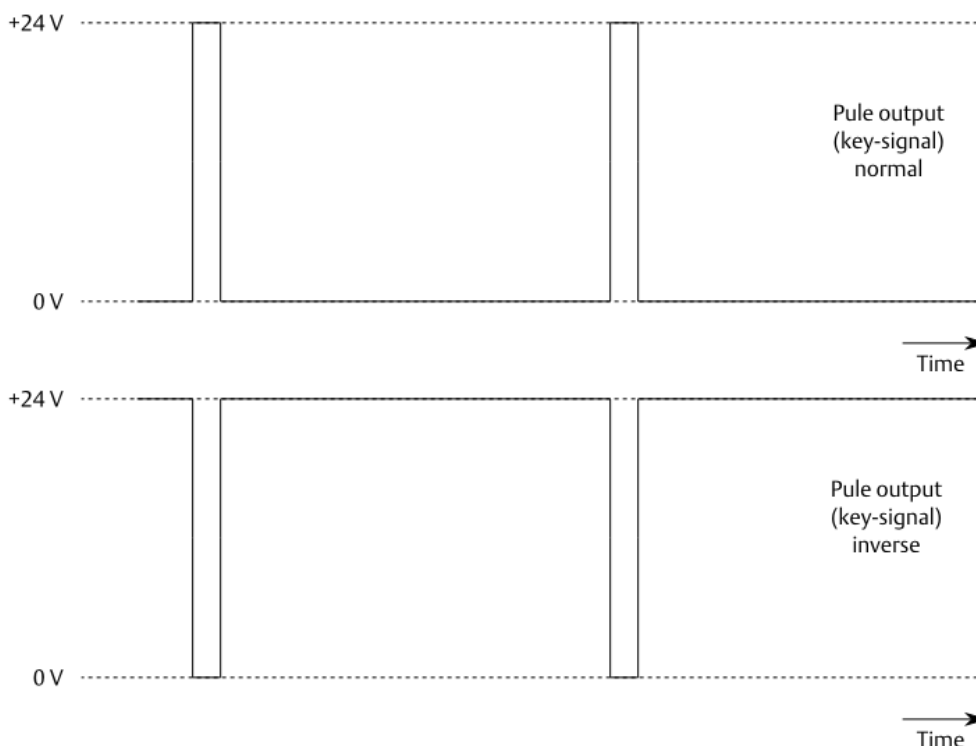

Display range minimum (speed) [RPM] and Display range maximum (speed) [RPM] Enter the speed range for the online display.

Display range minimum (acceleration) [RPM/s] and Display range maximum (acceleration) [RPM/s] Enter the speed acceleration range for the online display.

Activate test value Place a checkmark in this box to enable the test function. Before the test value becomes active it must be activated through a digital input (see [Speed - Digital inputs](#)) or through the software commands **Activate test value 1** for channel 1

or **Activate test value 2** for channel 2 in the ribbon command bar on page **Home**.

Test value target

Select the signal type of the test value.

- **Speed**
- **Acceleration**

Test value

Enter the test value in RPM or RPM/s depending on the signal type selected for parameter **Test value target**.

Timeout [s]

Define the duration of the active test value. After expiration of this time the test value will be deactivated and the card continues with the measurement.

Affect current out

Place a checkmark in this box to output the test value through the corresponding current output during the test.

Speed - Current output 1 and Current output 2

Define the function of the current outputs (see [Figure 6-56](#)). The current output 1 and the configuration page **Current output 1** are assigned to input channel 1 and the current output 2 and page **Current output 2** are assigned to input channel 2. For description of the optional parameters see [Current output 1 and Current output 2](#).

Figure 6-56: Current output 1 and Current output 2 - speed application

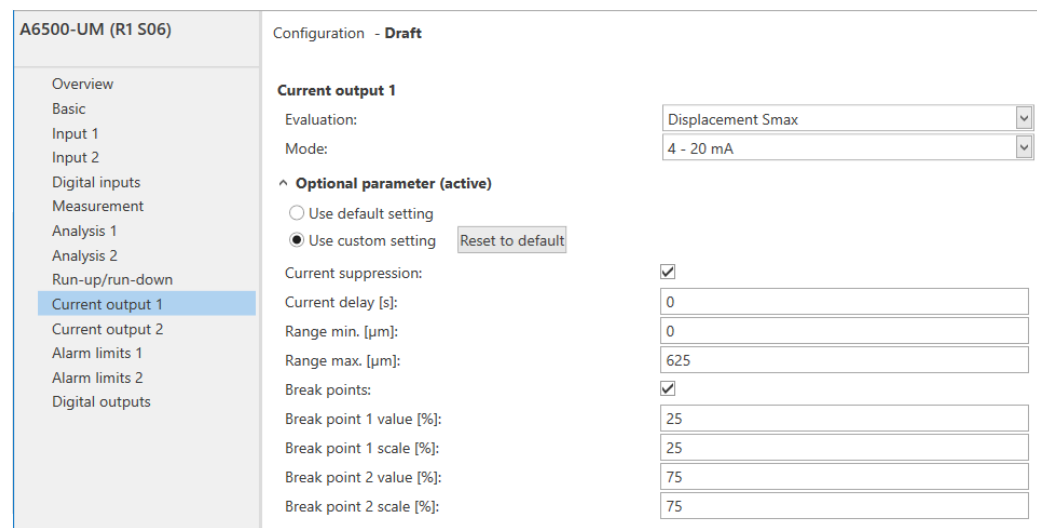

Evaluation Assign the current output to a signal evaluation.

- **Speed**
The current output is assigned to the measured speed value.
- **Acceleration**
The current output is assigned to the detected rotational acceleration.
- **Gap voltage**

The current output is assigned to the measured gap voltage. This evaluation is available with a connected eddy current sensor.

- **Off**
The current output is deactivated.

- Mode** Select the required output current range:
- 0 to 20 mA
 - 4 to 20 mA
Activation of the current suppression function is possible.
 - 20 to 4 mA
Activation of the current suppression function is possible.
 - 20 to 0 mA

Speed - Digital outputs

Define the function of the four digital outputs. Select the required settings from the selection table (see Figure 6-57 and Table 6-17). The digital outputs 3 and 6 are assigned to the Channel OK function – output 3 to channel 1 and output 6 to channel 2.

Figure 6-57: Configuration of digital outputs - speed application

Output	Data source	Function	Limit 1	Limit 2	Hysteresis	Circuit mode	LED 1	LED 2
DO 1	Ch 1 Speed	>= Limit	-	3100	10	Normally open	●	○
DO 2	Ch 1 GapWarning	Normal	-	-	-	Normally open	○	○
DO 3								
DO 4	Ch 2 Speed	>= Limit	-	3100	10	Normally open	○	●
DO 5	Ch 1 Standstill	Normal	-	-	-	Normally open	○	○
DO 6								
Channel not OK			-	-			○	○

Limit suppression
 Bypass affects Channel OK

Data source

Table 6-17: Table data source and function

Data source	Select function	Description
Speed channel 1	No function (Off)	Digital output has no function and is in the initial state.
	>= Limit	The switching characteristic of the output is increasing. The output will be set, if the speed value (RPM) has exceeded the limit value for this output. If the speed falls below the limit (limit value minus hysteresis) again, the output will be reset.
	>= Limit (Latch)	The switching characteristic of the output is increasing. The output will be set, if the speed value (RPM) has exceeded the limit value for this output. If the speed falls below the limit (limit value minus hysteresis) again, the output will only be reset after a Reset-Latch command was given.

Table 6-17: Table data source and function (continued)

Data source	Select function	Description
	<= Limit	The switching characteristic of the output is falling. The output will be set, if the speed value (RPM) has fallen below the limit value for this output. If the speed exceeds the limit (limit value plus hysteresis) again, the output will be reset.
	<= Limit (Latch)	The switching characteristic of the output is falling. The output will be set, if the speed value (RPM) has fallen below the limit value for this output. If the speed exceeds the limit (limit value plus hysteresis) again, the output will only be reset, after a Reset-Latch command was given.
	Window Inside	<p>The output is set, if the speed value (RPM) is outside the window defined by Limit 1 and Limit 2. If the speed exceeds the limits (limit values plus hysteresis) again – speed is inside the window, the output is reset.</p> <p>Figure 6-58: Window inside</p> <p>A. Limit 1 plus hysteresis B. Limit 2 plus hysteresis</p>
	Window Inside (Latch)	The output is set, if the speed value (RPM) is outside the window defined by Limit 1 and Limit 2 (see Figure 6-58). If the speed exceeds the limits (limit values plus hysteresis) again – speed is inside the window, the output is not automatically reset. Use the command Reset latch to reset the output.

Table 6-17: Table data source and function (continued)

Data source	Select function	Description
	Window Outside	<p>The output is set, if the speed value (RPM) is inside the window defined by Limit 1 and Limit 2. If the speed exceeds the limits (limit values plus hysteresis) again – speed is outside the window, the output is reset.</p> <hr/> <p>Figure 6-59: Window outside</p> <p>A. Limit 2 plus hysteresis B. Limit 1 plus hysteresis</p> <hr/>
	Window Outside (Latch)	<p>The output is set, if the speed value (RPM) is inside the window defined by Limit 1 and Limit 2 (see Figure 6-59). If the speed exceeds the limits (limit values plus hysteresis) again – speed is outside the window, the output is not automatically reset. Use the command Reset latch to reset the output.</p>
	< Limit, no zero speed	See Function < Limit, no zero speed .
Acceleration channel 1 ¹	No function (Off)	Digital output has no function and is in the initial state.
	>= Limit	<p>The switching characteristic of the output is increasing. The output will be set, if the acceleration value (RPM/s) has exceeded the limit value for this output. If the acceleration falls below the limit (limit value minus hysteresis) again, the output will be reset.</p>
	>= Limit (Latch)	<p>The switching characteristic of the output is increasing. The output will be set, if the acceleration value (RPM/s) has exceeded the limit value for this output. If the acceleration falls below the limit (limit value minus hysteresis) again, the output will only be reset after a Reset-Latch command was given.</p>

Table 6-17: Table data source and function (continued)

Data source	Select function	Description
	<= Limit	The switching characteristic of the output is falling. The output will be set, if the acceleration value (RPM/s) has fallen below the limit value for this output. If the acceleration exceeds the limit (limit value plus hysteresis) again, the output will be reset.
	<= Limit (Latch)	The switching characteristic of the output is falling. The output will be set, if the acceleration value (RPM/s) has fallen below the limit value for this output. If the acceleration exceeds the limit (limit value plus hysteresis) again, the output will only be reset, after a Reset-Latch command was given.
	Window Inside	See Speed channel 1 for description.
	Window Inside (Latch)	
	Window Outside	
Window Outside (Latch)		
Standstill channel 1	Normal	The output will be set if there are no pulses within the defined standstill time (see parameter Measurement → Standstill time [s]). the indication will be cancelled as soon as a pulse is detected at the input again. Digital output is activated and an assigned LED is switched on while a detected standstill.
	Inverse	Digital output is deactivated and an assigned LED is switched off while a detected standstill.
Gap Warning channel 1	Normal	The output will be set if the gap voltage exceeds the defined limit (see parameter Measurement → Gap threshold limit [V]). The warning will be cancelled as soon as the gap voltage is below the limit. Digital output is activated and an assigned LED is switched on during the gap warning.
	Inverse	Digital output is deactivated and an assigned LED is switched off during the gap warning.
Speed channel 2	See Speed channel 1 for description.	
Acceleration channel 2	See Acceleration channel 1 for description.	
Standstill channel 2	See Standstill channel 1 for description.	
Gap Warning channel 2	See Gap warning channel 1 for description.	
Diff. - Channel 1/2	No function (Off)	Digital output has no function and is in the initial state.

Table 6-17: Table data source and function (continued)

Data source	Select function	Description
	>= Limit	Configure both channels of the card for speed measurement to use this function. The Universal Measurement Card measures the speeds of both channels. When the speed difference between the channels exceeds the limit value an alarm will be output. Independently of which has the higher speed value The switching characteristic of the output is increasing. The output will be set, as soon as the difference between the speed values exceeds the limit. If the difference falls below the difference value (limit value minus hysteresis) again, the output will be reset.
	>= Limit (Latch)	The switching characteristic of the output is increasing. The output will be set, as soon as the difference between the speed values exceeds the limit. If the difference falls below the limit (limit value minus hysteresis) again, the output will only be reset after a Reset-Latch command was given.
	<= Limit	The switching characteristic of the output is falling. The output will be set, if the speed difference has fallen below the limit value for this output. If the difference exceeds the limit (limit value plus hysteresis) again, the output will be reset.
	<= Limit (Latch)	The switching characteristic of the output is falling. The output will be set, if the difference has fallen below the limit value for this output. If the difference exceeds the limit (limit value plus hysteresis) again, the output will only be reset, after a Reset-Latch command was given.
	Window Inside	See Speed channel 1 for description.
	Window Inside (Latch)	
	Window Outside	
	Window Outside (Latch)	
	RotDirection - Channel 1/2	Normal
Inverse		Digital output is deactivated and an assigned LED is switched off during a rotation against the preferred direction.

¹ See *Alarm behavior if data source "Acceleration" has been selected*

Limit Enter the limit value if required for the selected function. This entry field is only available if a function is selected which needs a limit.

Hysteresis Enter a hysteresis for the limit of the selected function. Entering a hysteresis is optional. This entry field is available if a function is

selected which needs a limit. The function of the hysteresis is described in [Alarm limits 1](#) and [Alarm limits 2](#).

- Circuit Mode** Select the operation principle for the corresponding digital output.
- **Normally open**
At an activated output, the output is conducting and an external connected relay will be switched.
 - **Normally closed**
At an activated output, the output is open and an external connected relay deactivated.
- LED 1 and LED 2** Assign the alarm LEDs of the card front to a digital output.
- Limit suppression** See [Alarm limits 1](#) and [Alarm limits 2](#).
- Bypass affects Channel OK** Click the checkbox to enable that a bypassed channel affects Channel OK. Behavior if a channel is bypassed:
- Box checked and bypass activated:
The Channel OK (COK) LED, assigned to the bypassed channel, on the front is switched off, the assigned digital COK output is opened. All functions related to Channel OK such as current suppression (**Current output** → **Current suppression**) react accordingly.
 - Box not checked and bypass activate:
An activated bypass does not affect Channel OK and assigned functions.

Alarm behavior if data source "Acceleration" has been selected

The following graph shows the behavior of the alarm functionality if data source **Acceleration** has been selected. As the acceleration can be in a positive or in a negative direction, the respective alarm limits can also be set as positive and negative values. See [Figure 6-60](#).

Figure 6-60: Alarm behavior acceleration

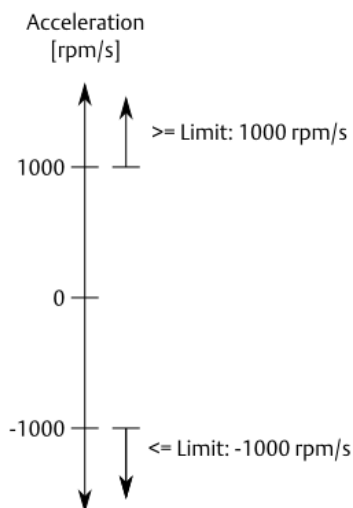

>= Limit (acceleration): positive alarm limit values

<= Limit (deceleration): negative alarm limit values

Function < Limit, no zero speed

If the decreasing speed falls below the defined limit and there is no zero speed detected, then the output is activated. The output is deactivated if zero speed is detected, or the speed is higher than the defined limit value plus hysteresis. Table 6-18 and Figure 6-61 show this behavior with an example limit value of 1 rpm and a hysteresis of 0.1 rpm.

Table 6-18: Operation sequence with limit value 1 rpm and 0.1 rpm hysteresis

Speed [rpm]	Direction (increasing/ decreasing)	Output (active, non-active)
1.000	decreasing	non-active
0.999	decreasing	active
0.000	decreasing	active
zero speed	-----	non-active
not zero speed	increasing	active
0.000	increasing	active
1.099	increasing	active
1.100	increasing	non-active

Figure 6-61: Example diagram “Operation sequence with limit value 1 rpm”

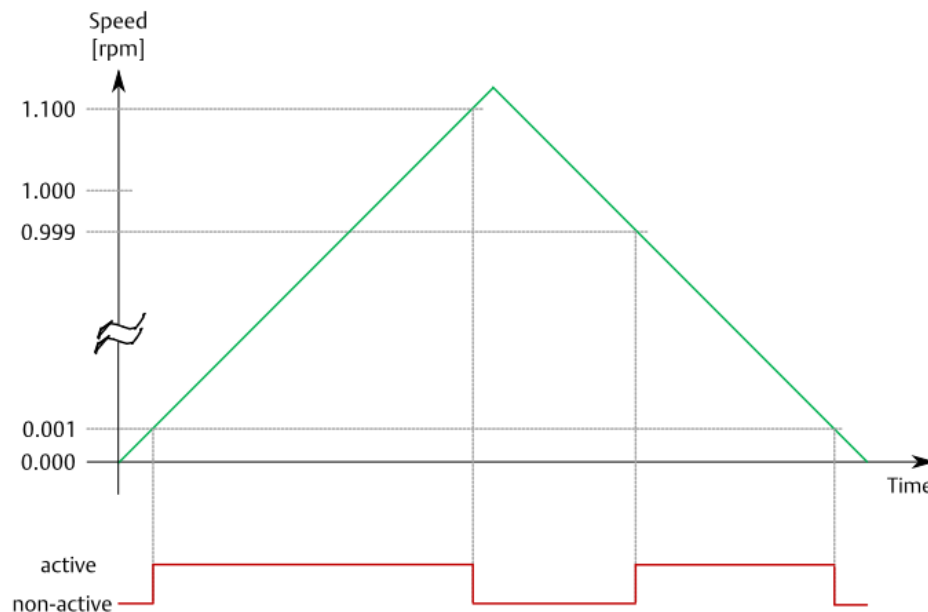

Speed – Speed diff. trigger 1 and 2

Define a differential speed trigger to trigger collection tasks depending on the machine's speed behavior. See AMS Machine Studio – General Functions for further information about collection tasks. Page **Speed diff. trigger 1** is assigned to channel 1 and page **Speed diff. trigger 2** is assigned to channel 2.

Figure 6-62: Speed diff. trigger 1 and Speed diff. trigger 2

A6500-UM (R1 S01)		Configuration 10/10/2019 8:38:33 AM - Running	
<ul style="list-style-type: none"> Basic Input 1 Input 2 Digital inputs Measurement 1 Measurement 2 Current output 1 Current output 2 Digital outputs Speed diff. trigger 1 Speed diff. trigger 2 	Speed diff. trigger 1		
	Max. Trigger Range [RPM]:	<input type="text" value="3200"/>	
	Min. Trigger Range [RPM]:	<input type="text" value="2800"/>	
	Inc. Delta [RPM]:	<input type="text" value="50"/>	
	Dec. Delta [RPM]:	<input type="text" value="50"/>	

A definable speed difference is used to trigger collection tasks. A certain speed range is defined within speed differences are evaluated. The lower limit of this speed range is also the starting point for the difference calculation. Speeds outside of the defined speed range are not used to trigger collection tasks. Speed differences can be calculated in both directions:

- **Positive delta RPM**

The collection task is triggered if the difference between the basic speed and the current speed is greater than the configured positive speed difference (**Inc. Delta**). The

starting point for the difference calculation is the point where the speed exceeds the trigger range minimum limit – first basic speed. After the triggered data collection has finished, the trigger event becomes the new basic speed. This basic speed point is used for the next difference calculation. See [Figure 6-63](#).

The collection task is also triggered when the increasing speed exceeds the trigger range minimum limit.

- **Negative delta RPM**

The collection task is triggered if the difference between the current speed and the basic speed is greater than the configured negative speed difference (**Dec. Delta**). The starting point is the last detected basic speed. After the triggered data collection has finished, the trigger event becomes the new basic speed. This basic speed point is used for the next difference calculation. See [Figure 6-64](#).

The collection task is also triggered when the decreasing speed underruns the trigger range maximum limit.

Note

Because of external influences such as the start behavior of the AMS 6500 ATG, the starting point speed (basic speed) can be slightly different to the expected speed.

Figure 6-63: Positive delta RPM

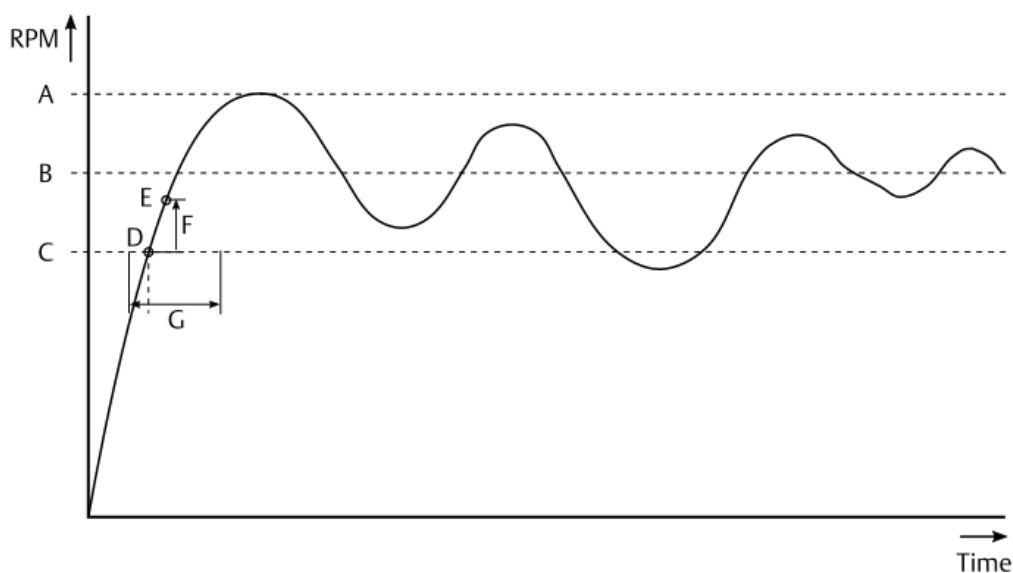

- A. Trigger range – maximum
 - B. Nominal speed
 - C. Trigger range – minimum
 - D. Basic speed (= trigger range minimum after the first start of the system)
 - E. Trigger event and new basic speed
 - F. Positive delta RPM
 - G. Length of the data block with pre- and post time
-

Figure 6-64: Negative delta RPM

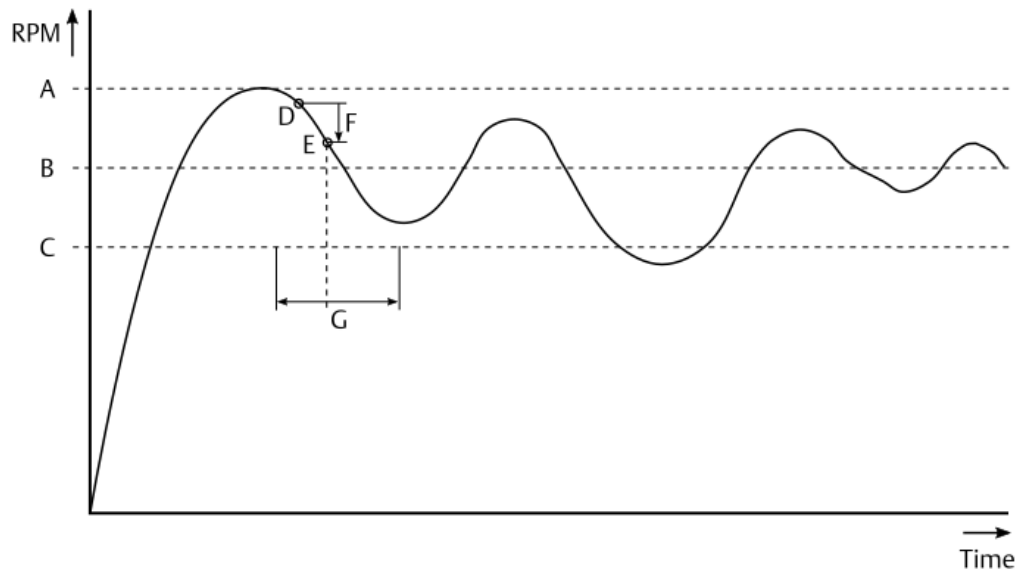

- A. Trigger range – maximum
- B. Nominal speed
- C. Trigger range – minimum
- D. Basic speed
- E. Trigger event and new basic speed
- F. Negative delta RPM
- G. Length of the data block with pre- and post time

Figure 6-65: Delta rpm around trigger range minimum

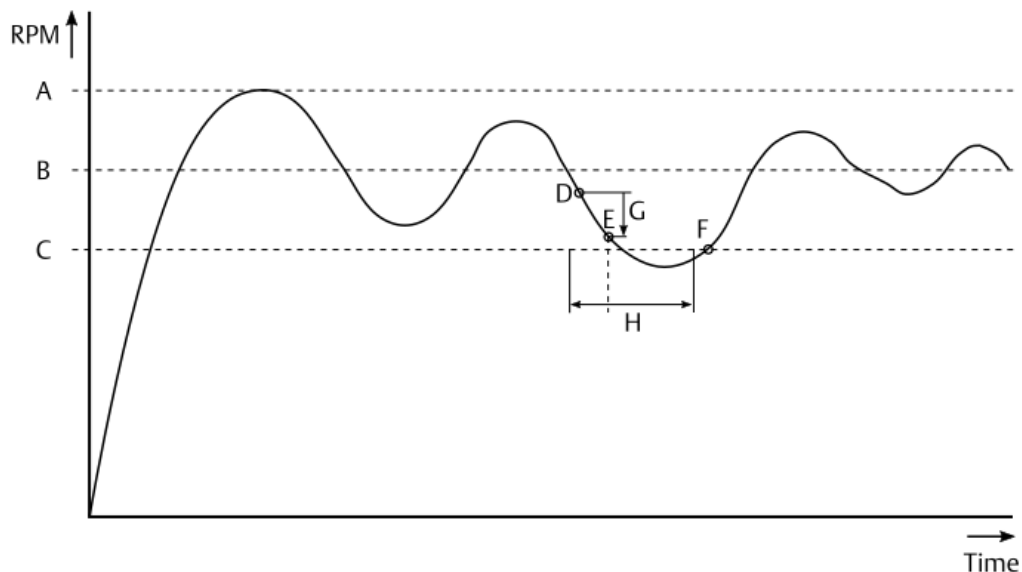

- A. Trigger range – maximum
- B. Nominal speed
- C. Trigger range – minimum
- D. Basic speed
- E. Trigger event
- F. New basic speed (= trigger range minimum)
- G. Negative delta RPM
- H. Length of the data block with pre- and post time

Min. Trigger Range	Enter the minimum limit for the speed range that defines the trigger range.
Max. Trigger Range	Enter the maximum limit for the speed range that defines the trigger range. Only speeds within this range are used to trigger collection tasks.
Inc. Delta	Enter a speed difference to define the positive delta RPM trigger event. The trigger point is the basic speed plus the entered difference. The minimum entry is 1 rpm.
Dec. Delta	Enter a speed difference to define the negative delta RPM trigger event. The trigger point is the basic speed minus the entered difference. The minimum entry is 1 rpm.

6.7 Send and reload a configuration

6.7.1 Send a configuration

⚠ CAUTION

The machine protection function of the card is disabled during sending of configurations with major changes, because of a reboot of the A6500-UM Card.

Note

Modbus requests are answered with **Server Device Busy (0x06)** when sending a configuration.

Whether or not a reboot is required will depend on the changes to the configuration. The following changes do not require a reboot of the card:

- Names and texts
- Alarm limits
- Alarm related settings such as delay, latching, and alarm hysteresis.

Procedure

1. Ensure that there is an online connection between the A6500-UM Card and AMS Machine Studio running on a PC or laptop.
AMS Machine Studio will automatically establish an online connection to the cards of the AMS 6500 ATG system as soon as there is a physical connection through the USB port of the A6500-CC Com Card of the system. At TCP/IP connection click **Connect ATG** on the ribbon command bar of page **Home** to establish a connection.
2. Click **Send & close** in the ribbon command bar to send the configuration to the card.

A confirmation dialog opens in accordance to the boot requirement:

Figure 6-66: Confirmation – overwrite configuration without reboot

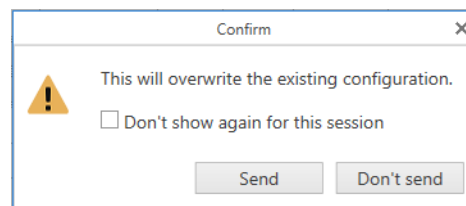

Click **Send** to overwrite the existing configuration without reboot.

Place a checkmark in the box **Don't show again for this session** to send further configurations without confirming the dialog. This selection is reset when AMS Machine Studio is closed.

Figure 6-67: Confirmation – overwrite configuration and reboot required

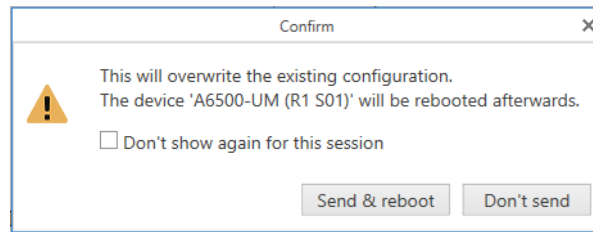

Click **Send & reboot** to overwrite the existing configuration and to reboot the A6500-UM Card afterwards. The machine protection function of the card is disabled during the process.

Place a checkmark in the box **Don't show again for this session** to send further configurations and reboot the card without confirming the dialog. This selection is reset when AMS Machine Studio is closed.

The configuration editor automatically closes afterwards.

A successful sent configuration will be indicated by a message in the upper right corner of the software window. This message window automatically disappears. Otherwise close it by clicking on the cross.

The Modbus registers are automatically updated according to the sent configuration unless the AMS 6500 ATG is not protected by a password. The successful update is also indicated by a message in the upper right corner (see [Figure 6-68](#)).

Figure 6-68: Modbus synchronization

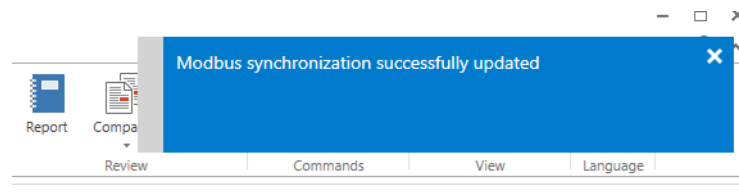

The card is ready to use when the **OK** LED on the card front of the configured channel shows a green steady light.

6.7.2 Reload a configuration

Once an online connection has been established, the configuration of all cards of a AMS 6500 ATG system are automatically loaded to AMS Machine Studio. Click **Reload** in the ribbon command bar if the configuration of the card must be loaded again.

7 Online view

After connection to an A6500-xR System Rack, the online view of the connected rack appears on the main page of AMS Machine Studio. [Figure 7-1](#) shows this view.

Figure 7-1: Overview online view

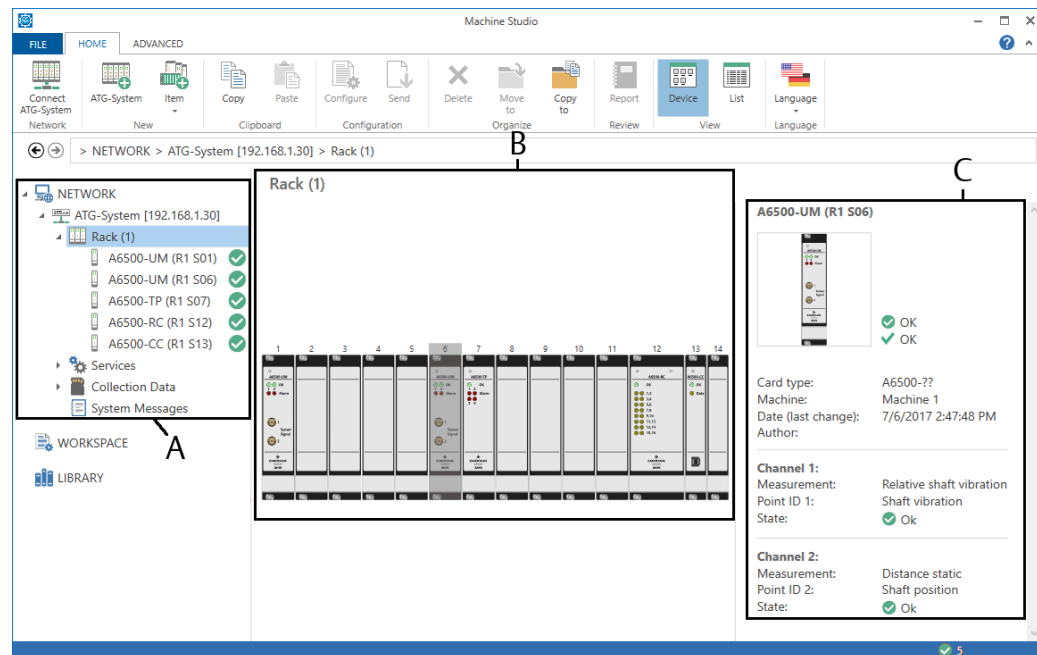

- A. Connected devices
- B. Main window with rack view
- C. A few details of the selected card from the rack overview

Select an A6500-UM card in the device tree or double click a A6500-UM card shown in the rack view to open the online view of the card. The online view has three pages. **Overview**, **Details**, and **Live data**. Machine name, plant name, area, serial number, module type, firmware version, date of last change to the configuration, and the author of the last configuration are shown at the top of each online view page. There are two small additional icons, **Not in sync** and **No configuration**. These icons appears on card symbol in the **Network** list if the card is not in sync or has no configuration.

Not in sync

Figure 7-2: Not in sync



An Universal Measurement Card not in sync is marked with this symbol. An Universal Measurement Card is "not in sync" if there is a draft configuration that has been not yet

send to the card. For example, a digital output configuration of an A6500-UM card has been changed and this change has been saved as draft.

1. Click the Universal Measurement Card not in sync in the listed of connected devices below **Network** to select the card. The row will be colored blue.
2. Click **Configure** in the ribbon command bar to open the editor.
3. Check the configuration.
4. Click **Send & close** to synchronize the card.

The configuration of the Universal Measurement Card is sent. The "not in sync" sign disappears after successful sending of the configuration.

No configuration

Figure 7-3: No configuration



An Universal Measurement Card without a configuration is marked with this symbol. This card state is also indicated by slowly alternate flashing of the green OK LEDs on the front plate.

Note

Use online view to find the cause of any unexpected behavior of the card.

7.1 Static and dynamic measurement applications

7.1.1 Overview

The content of the page **Overview** depends on the configured measurement application. [Figure 7-4](#) shows the overview page for a single channel application. For single channel applications, **Overview** displays information for each active channel. For combined channel applications, **Overview** displays the result of the channel combination (see [Figure 7-5](#)).

Figure 7-4: Overview – single channel application

A6500-UM (R1 S06)

Overview **Details** Live data

Type: A6500-UM	Machine: -	Configuration: ✓ OK	Date (last change): 10/27/2020 1:02:29 PM	Author:
Serial: 00000650	Firmware: 2.4.0.61 Beta	Hardware: 1	Plant: -	Area: -

Channel 1

Relative shaft vibration



Channel OK

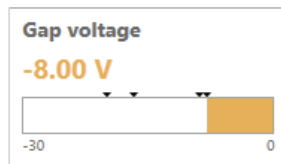

Limit suppression

Displacement 0-P

Gap voltage

Current suppression

Current output 1

Channel 2

Distance static

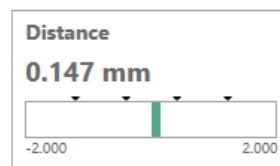

Channel OK

Limit suppression

Distance

Current suppression

Current output 2

Card

Card health

Global

Bypass DO 1-2

Bypass DO 4-5

DO 1 - Danger

DO 2 - Alert

CH 1 - Displacement 0...

CH 1 - Gap voltage

DO 3 - COK

DO 4 - Danger

DO 5 - Alert

DO 6 - COK

Figure 7-5: Overview – combined channel application

A6500-UM (R1 S06)

Overview **Details** Live data

Type: A6500-UM	Machine: -	Configuration: ✓ OK	Date (last change): 10/27/2020 12:55:47 PM
Serial: 00000650	Firmware: 2.4.0.61 Beta	Hardware: 1	Plant: -

Channel combined
Relative Shaft Vibration

Displacement Smax
62.58 μm

Displacement Smax
62.58 μm

Channel OK ✓

Limit suppression

Displ. Smax (1)

Displ. Smax (2)

Current suppression

Current output 1

Current output 2

Card

Card health ✓

Global

Bypass

DO 1 - Danger

DO 2 - Alert

CH 1&2 - Displaceme...

CH 1 - Gap voltage

DO 3 - COK

DO 4 - Danger

DO 5 - Alert

DO 6 - COK

Measurement value

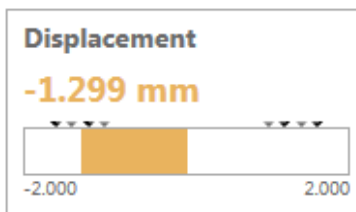

This graphic object displays the current value. The value is displayed as a numerical value and as a horizontal bar graph with measuring range, alarm limit indication (little black arrows), and hysteresis indication (little gray arrows). The bar graph changes color depending on the alarm state. The object is marked with CO (Current Output) if there are no digital outputs configured for that channel. Then the graphic object is assigned to the current output.

- Green: no alarm
- Yellow: alert alarm limit has been exceeded
- Red: danger alarm limit has been exceeded



For combined channel applications, two measurement value objects are displayed if both digital output channels are configured. Both are assigned to the combined value

Channel OK

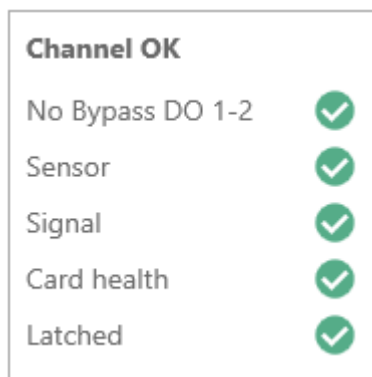
Figure 7-6: Channel OK



This graphic object shows the channel state.

- A fault-free channel is indicated by a checkmark within a green solid circle .
- A faulty channel is marked with a yellow warning triangle .

Click on **Channel OK** to expand the object and get more information about the channel state (see [Table 7-1](#)).

Table 7-1: Flags Channel OK











Flag	Meaning		Action
No bypass		Bypass is not active.	---
		Bypass is active.	Open GND connection at the corresponding digital input.
Sensor		No fault detected.	---
		Sensor fault detected.	Check the sensor including wiring and connections

Table 7-1: Flags Channel OK (continued)

Flag	Meaning		Action
Signal		No fault detected.	---
		Overload, the sensor signal is out of the valid voltage range (see Overload).	Check whether the installed sensor meets the requirements of the measuring task.
Card health		No fault detected.	---
		Card fault detected.	For more details see graphic object Card health .
Latched ¹		No latching active	
		Channel not OK state latched	If the other channel states (bypass, sensor, signal, and card health) are OK reset the Channel not OK state.
		Latching is deactivated for example during the start-up phase of the A6500-UM card	

¹ Visible if *Input* → *Channel OK latching* is activated.

Status flags

Figure 7-7: Status flags

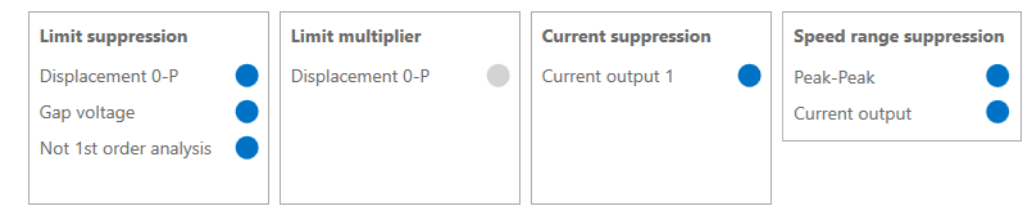

These graphic objects indicate the state of several status flags. Configured alarm groups such as **Distance**, **Gap voltage**, or **Band analysis** with enabled suppression or multiplier are listed in the related graphic objects. The number of flags depends on the card configuration.

- **Limit multiplier**
Each alarm group with an enabled limit multiplier is listed. The solid circle is blue if the assigned limit multiplier is active, otherwise the circle is gray.
- **Limit suppression**
Each alarm group with an enabled limit suppression is listed. The solid circle is blue if the assigned limit suppression is active, otherwise the circle is gray.
- **Current suppression**

The solid circle is blue if the assigned current suppression is active, otherwise the circle is gray.

- **Speed range suppression**

Depending on the selected **Out of speed range suppression mode** solid circles for evaluation alarms and the current output are shown. The solid circle is blue if the corresponding suppression is active because of a speed outside the configured range, otherwise the circle is gray.

Analysis

Figure 7-8: Analysis

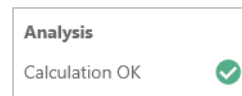

The checkmark within a green solid circle shows a valid calculation. Condition for a valid **Interval band by orders analysis** calculation:

- Speed is within the defined speed range (see [Speed range min](#) and [Speed range max](#))
- Speed has not changed by more than $\pm 2\%$ (unstable speed)
Interval bands are calculated anew if the speed is stable again.

An invalid calculation is indicated by a yellow warning triangle.



Alarm limits are suppressed if the calculation is not valid.

Card health

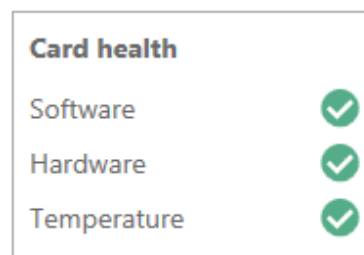
Figure 7-9: Card health









This graphic object indicates the card health.

- A fault free card is indicated by a checkmark within a green solid circle .
- A faulty card is marked with a yellow warning triangle .

Click on **Card health** to expand details about the card health. [Table 7-2](#) explains these flags.

Table 7-2: Card health flags

Flag	Meaning	Action	
Software		No fault detected.	---
		An issue with the firmware has been detected by the internal watchdog.	Restart the card by pulling and plugging it. If the issue still exists, replace the card.
Hardware		No fault detected.	---
		An issue with hardware parts on the card has been detected by the internal supervision function.	Replace the card.
Temperature		Not over temperature.	---
		The temperature, measured by the internal temperature sensor has exceeded the alert limit of 70°C.	Take appropriate measures to reduce the environmental temperature.
		The temperature, measured by the internal temperature sensor has exceeded the shut down limit of 80°C.	Emerson recommends to replace the card as parts might be stressed or damaged because of the high temperature. Take appropriate measures to reduce the environmental temperature.

Global flags

Figure 7-10: Global flags

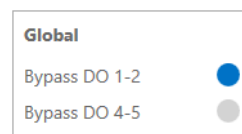

This graphic object shows the state of the global flags.

- **Bypass DO 1-2 and Bypass DO 4-5**
Indicates if the bypass for the digital outputs DO 1 and DO 2 or DO 4 and DO 5 is active. The solid circle is blue if the bypass of the corresponding digital outputs is active, otherwise the circle is gray.
- **Bypass**
Indicates if the bypass for applications with calculation based on two channels is activated. The solid circle is blue if the bypass is active, otherwise the circle is gray.

Digital outputs

Figure 7-11: Digital outputs

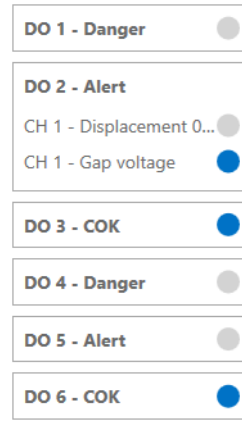

This graphic object shows the logical state of the digital outputs. Click on a digital output (DO) to see the state of the assigned alarms. The solid circle is blue if the configured condition is true, otherwise the circle is gray.

Bands

This graphic object is available if **Band Analysis** is selected on configuration page **Analysis** and alarm limits are enabled for **Band Analysis**. Click on the row **Bands** to expand the object. The amplitude of the configured frequency bands are displays as an horizontal bar graph diagram ([Figure 7-12](#)).

Figure 7-12: Overview - Bands

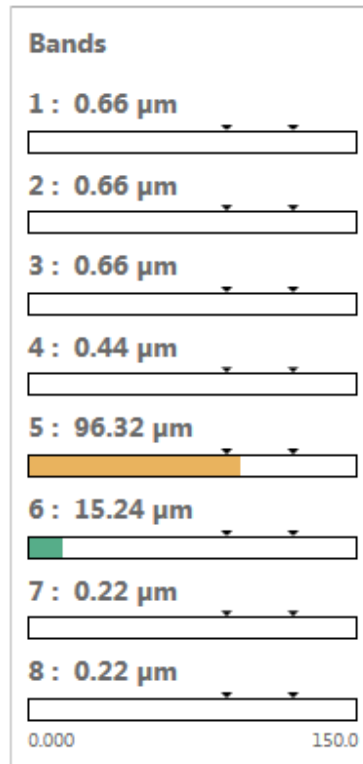

Interval band by frequency analysis

This graphic object is available if **Interval band by frequency analysis** is selected on configuration page **Analysis** and alarm limits are enabled for **Interval band by frequency analysis**. Click on the row **Interval b. (Freq.)** to expand the object. The calculated value within the configured frequency bands are displays as an horizontal bar graph diagram (Figure 7-13).

Figure 7-13: Overview – Interval band by frequency analysis

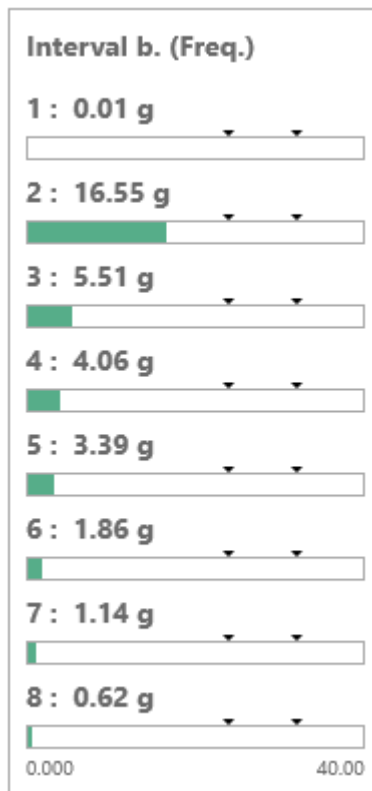

Interval band by orders analysis

This graphic object is available if **Interval band by orders analysis** is selected on configuration page **Analysis** and alarm limits are enabled for **Interval band by orders analysis**. Click on the row **Interval b. (orders)** to expand the object. The calculated value within the configured order bands are displays as an horizontal bar graph diagram (Figure 7-14).

Figure 7-14: Overview – Interval band by orders analysis

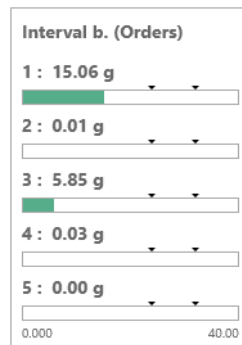

PeakPhase

This graphic object is available if **Order Analysis including PeakPhase** has been selected on configuration page **Analysis** and alarm limits are enabled for **Order Analysis including PeakPhase**. The amplitude and phase of the selected orders for PeakPhase are displayed as a polar chart (see [Figure 7-15](#)).

Figure 7-15: Overview – PeakPhase

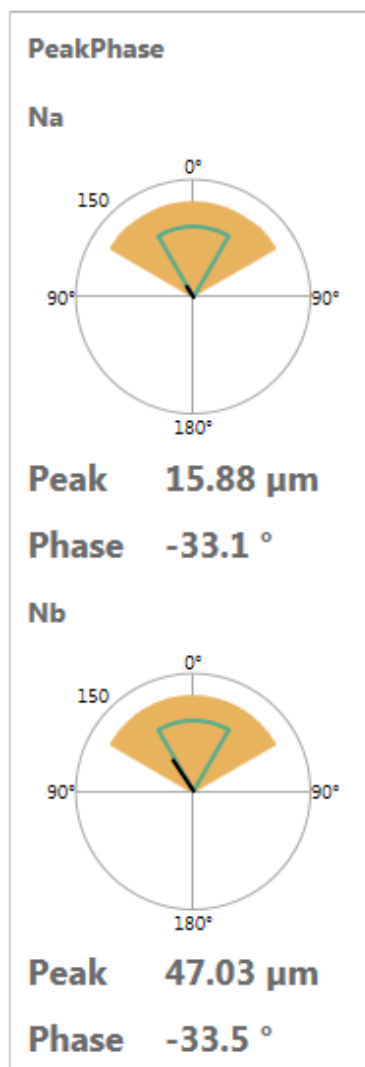

Measurement value – PeakVue analysis

This graphic object is available if **Analysis** → **PeakVue analysis** is selected and **Alarm limits** → **PeakVue analysis** → **Enabled** is activated. The current value of the measurement **PeakVue analysis** including measuring range and alarm limit markings is displayed. The bar graph changes color depending on the alarm state:

- Green: no alarm
- Yellow: alert alarm limit has been exceeded

- Red: danger alarm limit has been exceeded

Figure 7-16: Measurement value – PeakVue analysis



Measurement value – Not 1st order

This graphic object is available if **Analysis** → **Not 1st order analysis** is selected and **Alarm limits** → **Not 1st order analysis** → **Enabled** is activated. The current value of the measurement **Not 1st order** including measuring range and alarm limit markings is displayed. The bar graph changes color depending on the alarm state:

- Green: no alarm
- Yellow: alert alarm limit has been exceeded
- Red: danger alarm limit has been exceeded

Figure 7-17: Measurement value – Not 1st order



7.1.2

Details

The content of the page **Details** depends on the configured measurement application. [Figure 7-18](#) shows the page for a single channel application. For single channel applications, **Details** displays information for each active channel. For combined channel applications, **Details** displays the result of the channel combination (see [Figure 7-19](#)). For the already described graphic objects on this page see [Overview](#).

Figure 7-18: Details – single channel application

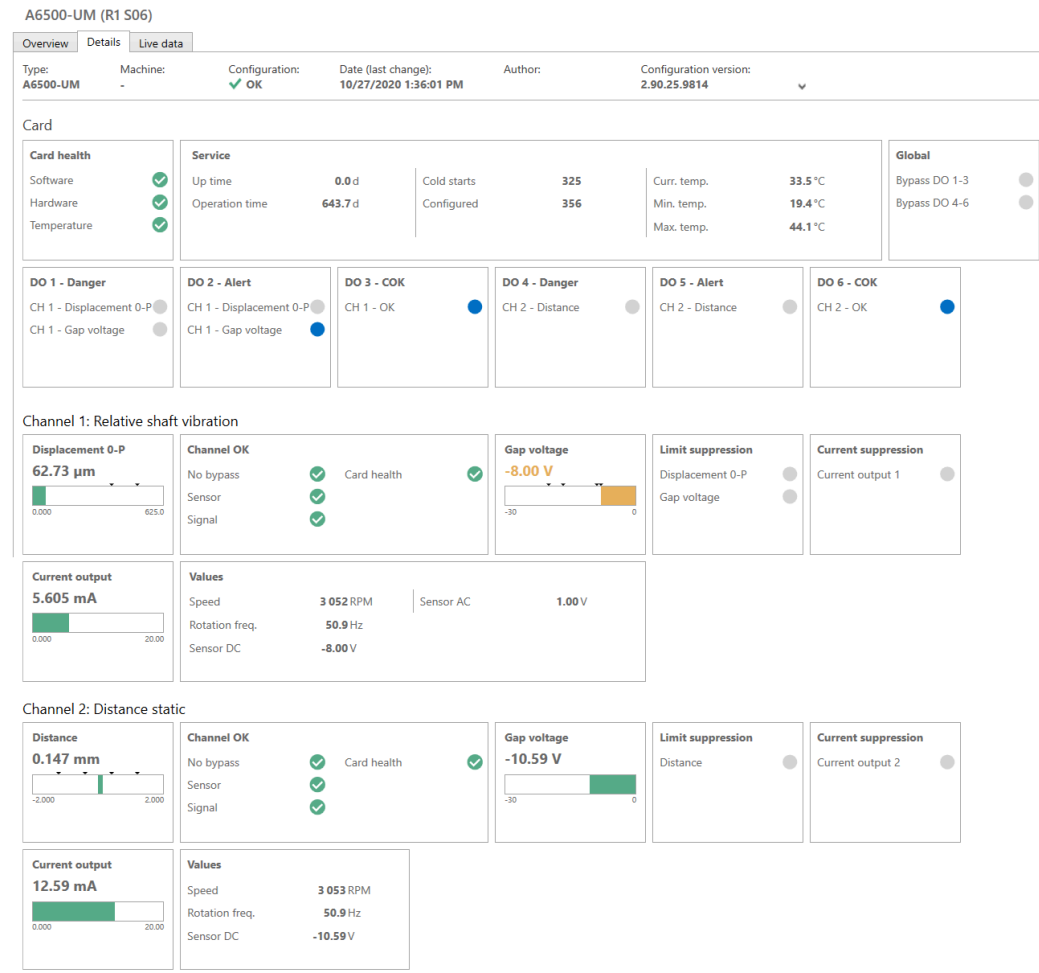

Figure 7-19: Details – combined channel application

A6500-UM (R1 S06)

Overview Details **Live data**

Type: A6500-UM Machine: - Configuration: **OK** Date (last change): 10/27/2020 2:27:01 PM Author: Configuration version: 2.90.25.9814

Card

Card health Software <input checked="" type="checkbox"/> Hardware <input checked="" type="checkbox"/> Temperature <input checked="" type="checkbox"/>	Service Up time 0.8 d Operation time 644.5 d Cold starts 325 Configured 357 Curr. temp. 33.5°C Min. temp. 19.4°C Max. temp. 44.1°C
---	---

Global Bypass <input type="checkbox"/>	DO 1 - Danger CH 1&2 - Displacemen... <input type="checkbox"/> CH 1 - Gap voltage <input type="checkbox"/>	DO 2 - Alert CH 1&2 - Displacemen... <input type="checkbox"/> CH 1 - Gap voltage <input type="checkbox"/>	DO 3 - COK CH 1 - OK <input checked="" type="checkbox"/>	DO 4 - Danger [no sources configured] <input type="checkbox"/>
DO 5 - Alert [no sources configured] <input type="checkbox"/>	DO 6 - COK CH 2 - OK <input checked="" type="checkbox"/>			

Channel combined: Relative Shaft Vibration

Displ. Smax (1) 62.77 µm 0.000 625.0	Displ. Smax (2) 62.77 µm 0.000 625.0	Limit suppression Displ. Smax (1) <input type="checkbox"/>	Current suppression Current output 1 <input type="checkbox"/> Current output 2 <input type="checkbox"/>	Current output 1 5.606 mA 0.000 20.00
Current output 2 5.606 mA 0.000 20.00	Values Speed 3 048 RPM Sensor 1 AC 1.00 V Rotation freq. 50.8 Hz Sensor 2 DC -10.59 V Sensor 1 DC -10.01 V Sensor 2 AC 0.00 V			

Channel 1

Channel OK No bypass <input checked="" type="checkbox"/> Sensor <input checked="" type="checkbox"/> Signal <input checked="" type="checkbox"/>	Card health <input checked="" type="checkbox"/>	Gap voltage -10.00 V -30 0	Limit suppression Gap voltage <input type="checkbox"/>
--	---	--	--

Channel 2

Channel OK No bypass <input checked="" type="checkbox"/> Sensor <input checked="" type="checkbox"/> Signal <input checked="" type="checkbox"/>	Card health <input checked="" type="checkbox"/>	Gap voltage -10.59 V -30 0
--	---	--

Service data

Figure 7-20: Service

Service					
Up time	0.0 d	Cold starts	38	Curr. temp.	34.0 °C
Operation time	37.5 d	Ok	87	Min. temp.	20.8 °C
				Max. temp.	38.0 °C

This graphic object contains service data:

- **Up time**
Days in operation since the last power on. This counter is reset at each power on and with every new configuration.
- **Operation time**
Days in operation since the first power on.
- **Cold starts**
Number of cold starts. This counter increments each time the card powers on.
- **Configured**
Number configurations sent to this card.
- **Curr. temp.**
Current temperature of the card measured by the card internal sensor.
- **Min. temp.** and **Max. temp.**
Minimum and maximum temperature of the card measured by the card internal sensor.

Current values

Figure 7-21: Values

Values			
Speed	2 964 RPM	Sensor AC	1.20 V
Rotation freq.	49.4 Hz		
Sensor DC	-9.99 V		

This graphic object contains the currently measured DC and AC voltage of the sensor signal. These values are, within the limits of accuracy, identical with the sensor raw signal

at the "Sensor Signal" sockets at the card front. Speed and rotation frequency are displayed as well if a key signal has been connected to the card.

Analog Output

Figure 7-22: Current output

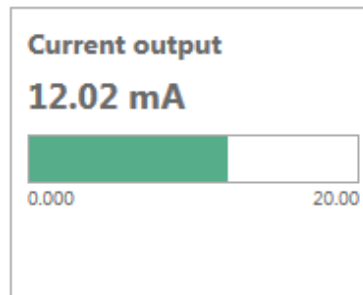

This graphic object shows the current value of the current output.

Orders, Orders Ref., and Bands

The visibility of these graphic objects depends on the configured analysis function.

The objects **Orders** and **Orders Ref.** are appears if the analysis function **Order Analysis including PeakPhase** is selected. The object **Orders** shows the calculated amplitude and phase of the selected orders. **Orders Ref.** shows the amplitude and phase of the base line vector of the PeakPhase function (see Figure 7-23).

Figure 7-23: Details – PeakPhase

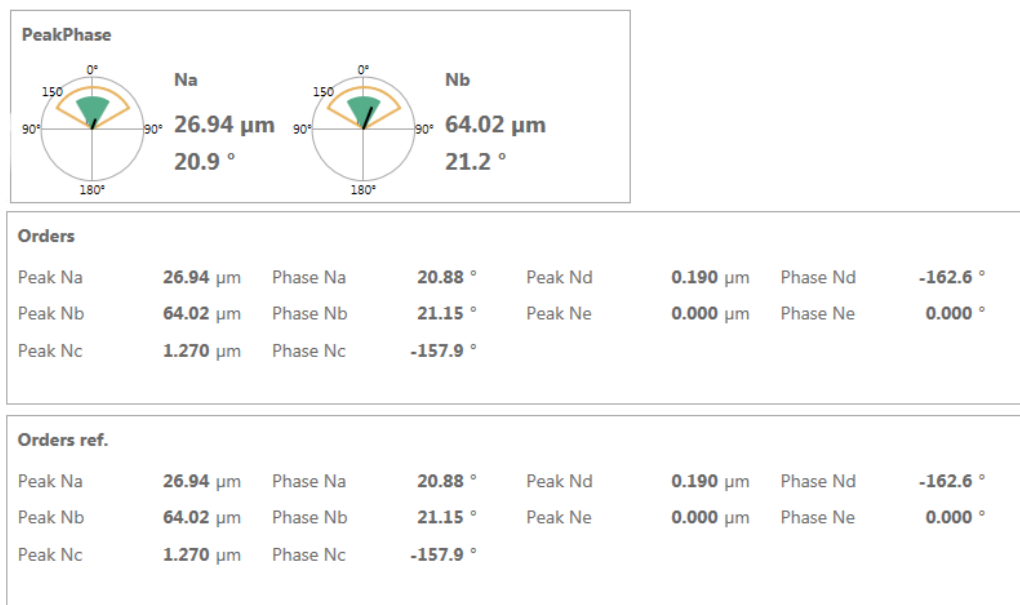

Bands appears if **Band Analysis** is selected. The object shows the amplitudes within the defined bands (Figure 7-24).

Figure 7-24: Details – Bands

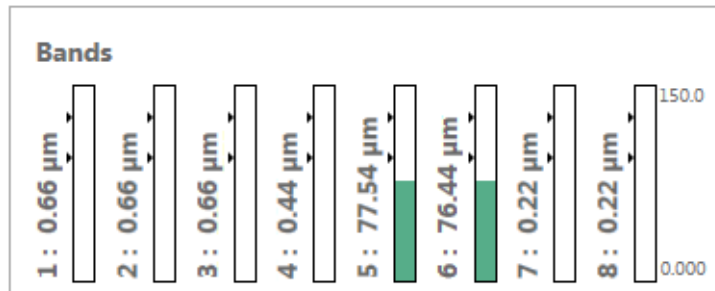

Interval b. (Freq.) appears if **Interval band by frequency analysis** is selected. The object shows the calculated value within the configured frequency bands (Figure 7-24). The displayed unit depends on the selected sensor and whether integration is active or not.

Figure 7-25: Details – Interval b. (Freq.)

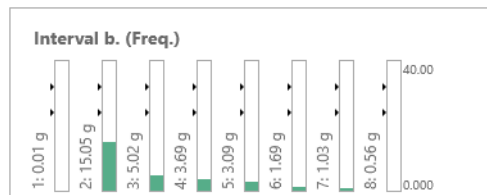

Interval b. (orders) appears if **Interval band by orders analysis** is selected. The object shows the calculated value within the configured order bands (Figure 7-26). The displayed unit depends on the selected sensor and whether integration is active or not.

Figure 7-26: Details – Interval b. (orders)

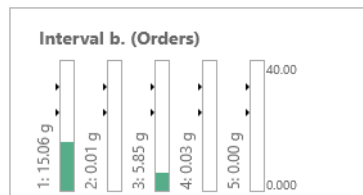

Cylinder pressure

The graphic objects **Chamber 1**, **Chamber 2** and **Rod load** contain the calculated measurement values of all available evaluations.

Figure 7-27: Cylinder pressure values

Head side (chamber 2)			
Suction pressure	740.5 kPa	Maximum pressure	740.6 kPa
Discharge pressure	740.5 kPa	Maximum pressure angle	85.9 °
Compression ratio	1.0	Minimum pressure	740.4 kPa
		Minimum pressure angle	309.8 °

Rod load	
Peak rod compression	7 105 kN
Peak rod tension	-2 842 kN
Peak rod compression angle	181.7 °
Peak rod tension angle	355.4 °
Deg. of rod rev.	94.6 °

Intersection point

The graphic object **Values** of the measurement application **Tandem** contains the currently active intersection point (see [Figure 7-28](#)).

Figure 7-28: Intersection point

Values			
Speed	2 965 RPM	Sensor 1 DC	-9.99 V
Rotation freq.	49.4 Hz	Sensor 2 DC	-9.99 V
Intersection point	0.00 mm		

Operation mode

The graphic object **Operation mode** indicates the currently active alarm limit set (see [Alarm limits 1](#) and [Alarm limits 2](#)). An activated alarm limit set is marked with a blue solid circle. Deactivated alarm limit sets are marked with a gray solid circle.

Figure 7-29: Operation mode

Operation mode	
Operation mode 1	<input type="radio"/>
Operation mode 2	<input checked="" type="radio"/>
Operation mode 3	<input type="radio"/>
Operation mode 4	<input type="radio"/>

Measure result OK

This object is available for the **Distance static** application using the **Rod drop triggered mode** and **Cylinder pressure** applications, and for dynamic measurements using **Not 1st order analysis**. **Rod drop triggered mode**, **Cylinder pressure**, and **Not 1st order analysis**

require a key signal for the measurement. The displayed measurement value is only valid if a valid key signal was available during the measurement.

A measurement with a valid key signal is indicated by a checkmark within a green solid circle.

A measurement with an invalid key signal is indicated by a yellow warning triangle.

Figure 7-30: Measure Result OK

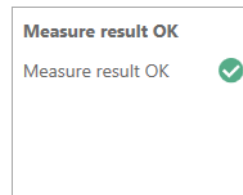

Gap voltage

This object is available for channels with a connected eddy current measuring chain. The DC part of the input signal including voltage range and alarm limit markings, if configured, is displayed. The bar graph changes color depending on the alarm state:

- Green: no alarm
- Yellow: alert alarm limit has been exceeded
- Red: danger alarm limit has been exceeded

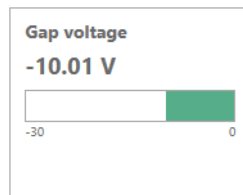

7.1.3 Live data

The content of the **Live data** page depends on the configured measurement application. [Figure 7-31](#) shows the page for a single channel application. For single channel applications, **Live data** displays information for each active channel. For combined channel applications, **Live data** displays the result of the channel combination (see [Figure 7-32](#)).

Time data consisting of time waveform, frequency spectrum, and phase is displayed for all dynamic measurements. **Live data** of combined channels with dynamic measurement displays time data of each single channel.

Use the control elements in the upper right corner of each diagram to change the diagram view. [Table 7-3](#) explains the control elements. Right-click on the diagram to reset the view.

Table 7-3: Diagram control elements





Control element	Function
	<p>Zoom</p> <p>Use this function to enlarge an interesting part of the diagram. Click the zoom icon to activate the zoom function. The button is colored light blue if zoom is activated, otherwise the button is gray.</p> <p>Place the mouse cursor close to the area of interest, left-click and hold. Move the mouse to frame the area of interest. Release the mouse button to enlarge the selected area.</p>
	<p>Move</p> <p>Use this function to move the entire view. Click the move icon to activate the function. The button is colored light blue if move is activated, otherwise the button is gray.</p> <p>Left-click an arbitrary point in the diagram and hold. Move the view to the desired position, and release the mouse button to place the view at that point.</p>
	<p>Zoom in</p> <p>Use this function to stepwise enlarge the diagram view. Click the zoom in icon to activate the function. The button is colored light blue if zoom in is activated, otherwise the button is gray.</p> <p>Left-click an arbitrary point in the diagram view. At every click, the diagram view is enlarged.</p>
	<p>Zoom out</p> <p>Use this function to stepwise reduce the diagram view. Click the zoom out icon to activate the function. The button is colored light blue if zoom out is activated, otherwise the button is gray.</p> <p>Left-click an arbitrary point in the diagram view. At every click, the diagram view is reduced.</p>

Figure 7-31: Live data - single channel application

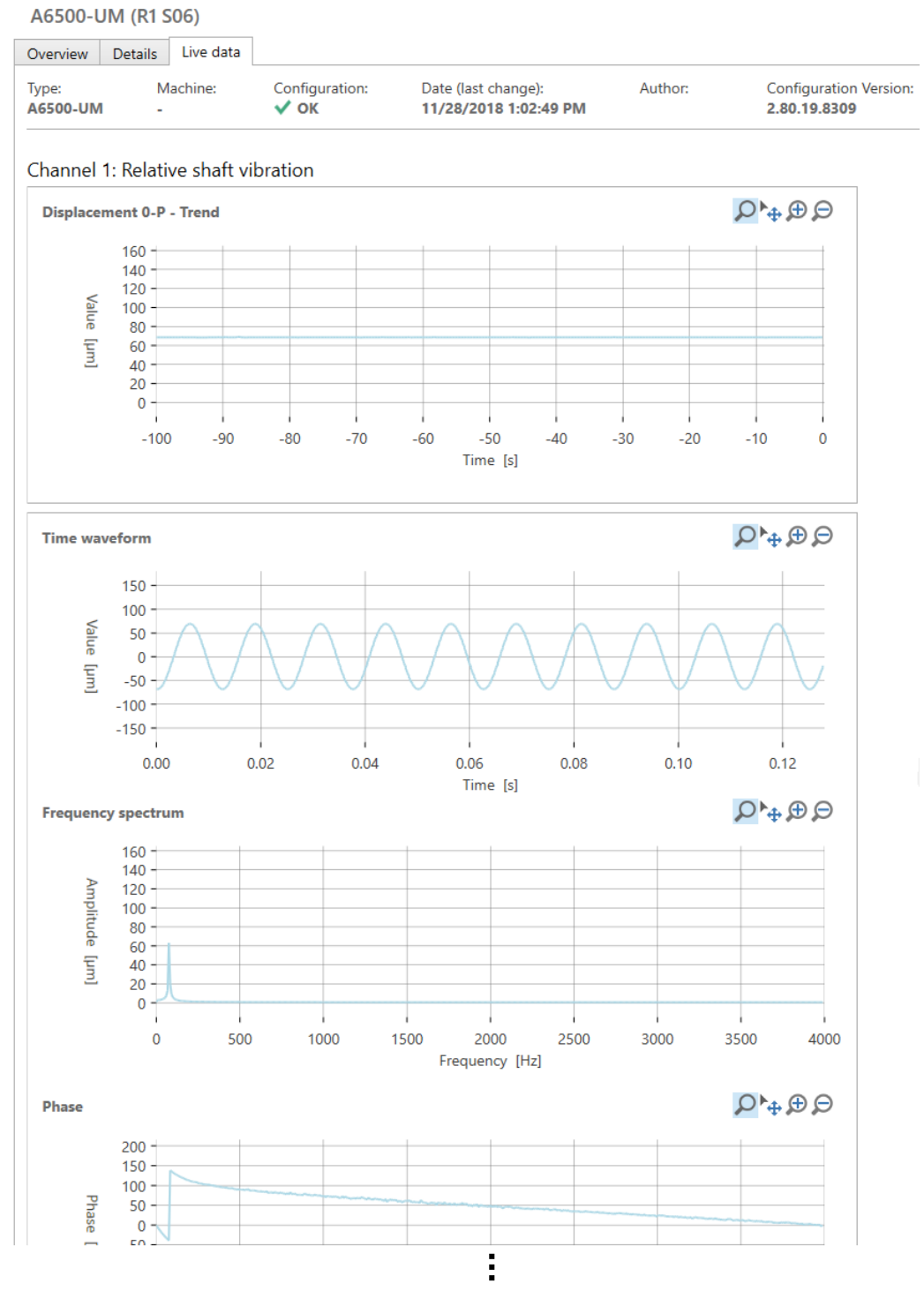
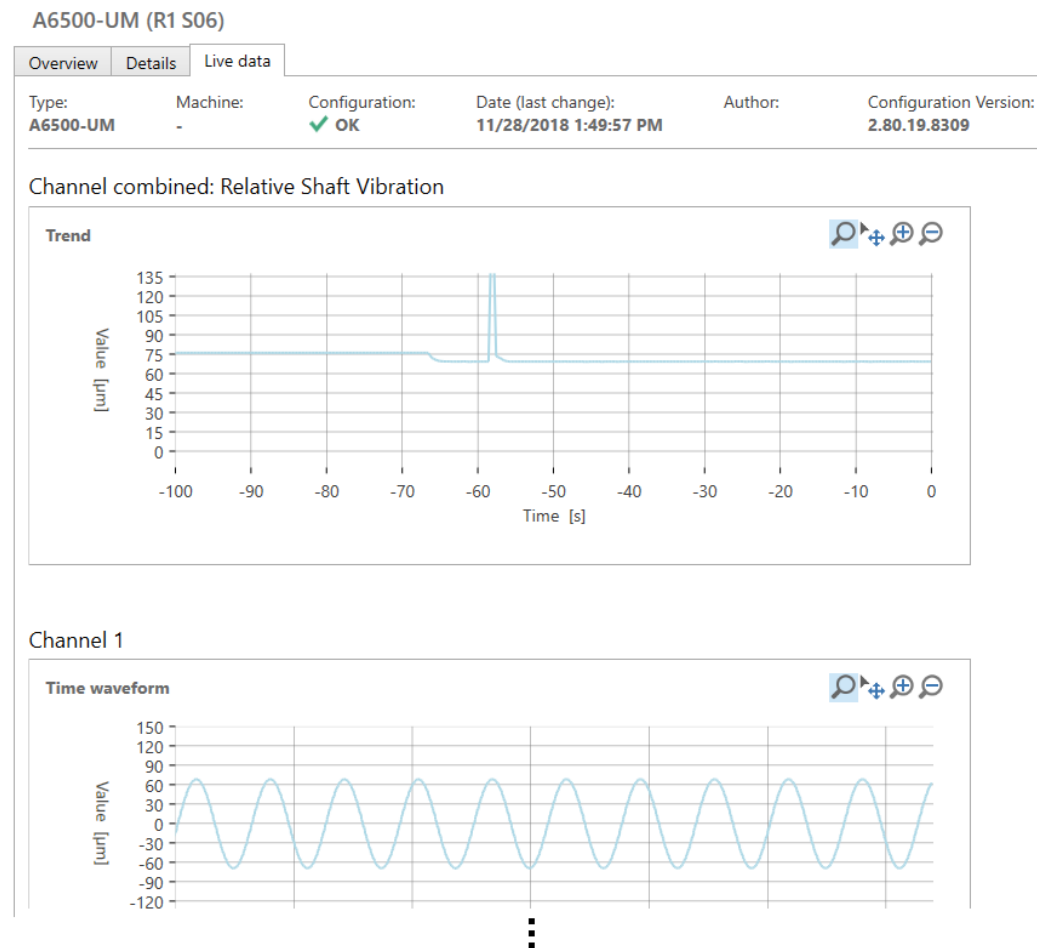

Figure 7-32: Live data - combined channel application



The time waveforms of the single channels are also displayed below the combined trend waveform.

Trend diagrams, time waveforms, phase diagrams, and PeakVue waveforms display depending on the selected measurement application.

Note

Time data cannot be read through the USB interface. That means live data of the A6500-UM card cannot be displayed if the card is connected through the USB interface.

Run-up or run-down

A recorded run-up or run-down, stored in the A6500-UM card, is displayed on the **Live data** page. This chart is available when the recording of run-ups and run-downs is enabled in the configuration (see [Run-up / run-down 1](#) and [Run-up / run-down 2](#)).

Figure 7-33: Run-up or run-down recording

Channel 2: Distance static

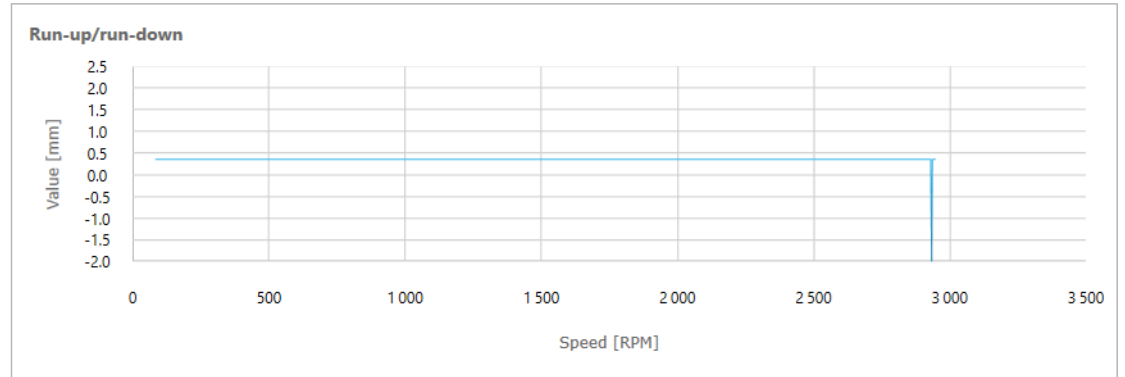

7.2 Online view - speed application

7.2.1 Overview

The content of the page **Overview** depends on the configured speed application. [Figure 7-34](#) shows the overview page for a single channel speed application. For single channel applications information display for each active channel. [Figure 7-35](#) shows the overview page for a redundant speed application.

Figure 7-35: Overview - redundant speed application

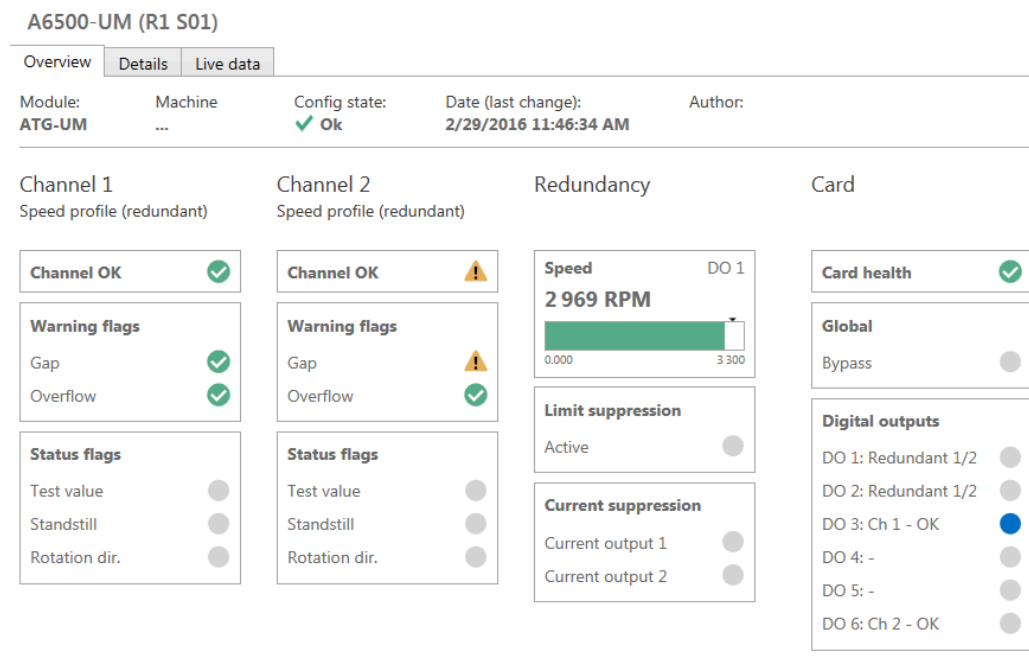

Channel OK

Figure 7-36: Channel OK



This graphic object shows the channel state.

- A fault free channel is indicated with a check mark within a green solid circle.
- A faulty channel is marked with a yellow warning triangle.

Click on **Channel OK** to expand details about the channel state (see [Table 7-4](#)).

Table 7-4: Speed - flags Channel OK





Flag	Meaning	Action
No Bypass	 Bypass is not active	---
	 Bypass is active	Open GND connection at the corresponding digital input.
Sensor	 No fault detected.	---
	 Sensor fault detected	Check the sensor including wiring and connections.

Table 7-4: Speed - flags Channel OK (continued)

Flag	Meaning		Action
Signal	✓	No fault detected.	---
	⚠	Overload, the sensor signal is out of the valid voltage range.	Check whether the installed sensor meets the requirements of the measuring task.
Card health	✓	No fault detected.	---
	⚠	Card fault detected.	For more details see graphic object "Card health".

Measurement value

Figure 7-37: Measurement value

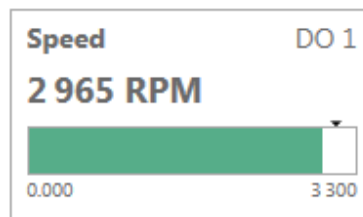

This graphic object displays the current speed or acceleration value. Which value is displayed depends on the selected evaluation for the current output (see configuration page **Current output**, parameter **Evaluation**). The value is displayed as a numerical value and as a horizontal bar graph with measuring range and alarm limit indication. The bar graph changes color depending on the configured limits.

- Green: no alarm
- Red: danger alarm limit has been exceeded

For each digital output configured with a limit value function a measurement value object is displayed. A short form of the assigned digital output is shown in the upper right corner of the object, for example, "DO 1" is for digital output 1.

Warning flags

Figure 7-38: Warning flags

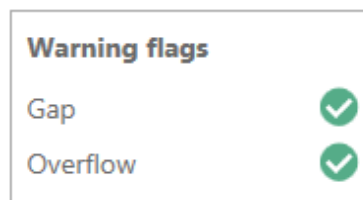

This graphic object indicates the state of several warning flags.

- **Gap warning**
A gap warning is indicated with a yellow warning mark. A gap warning is indicated if the DC part of the sensor voltage is below the configured gap threshold limit (page **Measurement**, parameter **Gap threshold limit**). In this case, check the distance between sensor and trigger wheel. The circle is gray if the DC part of the sensor voltage is above the gap threshold limit - no gap warning.
- **Overflow**
An overflow is indicated with a yellow warning mark. An overflow is indicated if the displayed speed is greater than or equal to 999999 rpm.

Status flags

Figure 7-39: Status flags



This graphic object indicates the state of several status flags. The number of flags depends on the card configuration.

- **Test value**
The solid circle is blue if the test value is active, otherwise the circle is gray.
- **Standstill**
The solid circle is blue if a standstill has been detected, otherwise the circle is gray.
- **Rotation dir.**
The solid circle is blue if a rotation against the preferred direction of rotation has been detected, otherwise the circle is gray. See parameter "Preferred rotation direction" on configuration page "Measurement" for the configured preferred direction.

Limit suppression

Figure 7-40: Limit suppression



This graphic object indicates the state of the limit suppression.

The solid circle is blue if the limit suppression is active, otherwise the circle is gray.

Current suppression

Figure 7-41: Current suppression

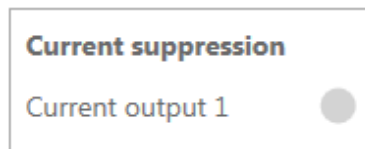

This graphic object indicates the state of the current suppression function.
The solid circle is blue if the current suppression is active, otherwise the circle is gray.

Card health

Figure 7-42: Card health



This graphic object indicates the card health.

- A fault free card is indicated with a check mark within a green solid circle.
- A faulty card is marked with a yellow warning triangle.

Click on the row **Card health** to expand the object and get more information about the card health. [Table 7-5](#) explains these flags.

Table 7-5: Speed - card health flags

Flag	Meaning	Action	
Software		No fault detected.	---
		An issue with the firmware has been detected by the internal watchdog.	Restart the card by pulling and plugging it. If the issue still exists, replace the card.
Hardware		No fault detected.	---
		An issue with hardware parts on the card has been detected by the internal supervision function.	Replace the card.
Temperature		No over temperature.	---
		The temperature, measured by the internal temperature sensor has exceeded the alert limit of 70°C.	Take appropriate measures to reduce the environmental temperature.

Table 7-5: Speed - card health flags (continued)

Flag	Meaning	Action
	 The temperature, measured by the internal temperature sensor has exceeded the shut down limit of 80°C.	We recommend to replace the card as parts might be stressed or damaged because of the high temperature. Take appropriate measures to reduce the environmental temperature.

Global flags

Figure 7-43: Global

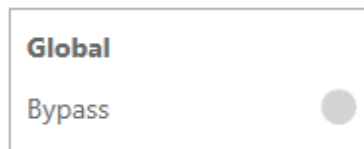

This graphic object shows the state of the global flags.

- **Bypass**
Indicates if the bypass for one channel or for both channels is activated. The solid circle is blue if at least the bypass of one channel is active, otherwise the circle is gray.

Digital outputs

This graphic object shows the logical state of the digital outputs. The solid circle is blue if the configured condition is true, otherwise the circle is gray.

7.2.2 Details

The content of the page **Details** depends on the configured speed application. [Figure 7-44](#) shows the page for a single channel speed application. [Figure 7-45](#) shows the page for a redundant speed application. For the already described graphic objects on this page see [Overview](#).

Figure 7-44: Details - single channel speed application

A6500-UM (R1 S01)

Overview **Details** Live data

Module: **ATG-UM** Machine: ... Config state: **✓ Ok** Date (last change): **2/29/2016 1:54:09 PM** Author: ...

Card

Card health	Service	Global
Software ✓	Up time 0.1 d Cold starts 43 Curr. temp. 34.6 °C	Bypass <input type="radio"/>
Hardware ✓	Operation time 50.1 d Ok 28 Min. temp. 20.9 °C	
Temperature ✓	Max. temp. 37.4 °C	

Digital outputs

DO 1: Ch 1 <input type="radio"/>	DO 4: - <input type="radio"/>
DO 2: Ch 1 <input type="radio"/>	DO 5: - <input type="radio"/>
DO 3: Ch 1 - OK <input checked="" type="radio"/>	DO 6: Ch 2 - OK <input type="radio"/>

Channel 1: Speed

Speed DO 1 2967 RPM 	Acceleration -4.548 RPM/s 	Channel OK	Limit
		No bypass ✓ Card health ✓	Suppression <input type="radio"/>
		Sensor ✓	
		Signal ✓	

Current suppression	Current output	Warning flags	Status flags
Current output 1 <input type="radio"/>	18.39 mA 	Gap ✓	Test value <input type="radio"/>
		Overflow ✓	Standstill <input type="radio"/>
			Rotation dir. <input type="radio"/>

Status values

Speed	2966 RPM	Test value	2966 RPM	Sens. sig. min.	-4.626 V
min.	0.000 RPM	Rotation freq.	49.43 Hz	Sens. sig. max.	-2.602 V
max.	2978 RPM	Acc.	-4.023 RPM/s		

Figure 7-45: Details - redundant speed application

A6500-UM (R1 S01)

Overview Details **Live data**

Module: ATG-UM Machine: ... Config state: **Ok** Date (last change): 2/29/2016 2:10:50 PM Author: ...

Card

Card health Software Hardware Temperature	Service Up time 0.0 d Cold starts 43 Curr. temp. 33.3 °C Operation time 50.1 d Ok 30 Min. temp. 20.9 °C Max. temp. 37.4 °C	Global Bypass
---	---	-------------------------

Digital outputs

DO 1: Redundant 1/2	DO 4: -
DO 2: Redundant 1/2	DO 5: -
DO 3: Ch 1 - OK	DO 6: Ch 2 - OK

Channel 1: Speed profile (redundant)

Speed 2 969 RPM 	Acceleration 3.312 RPM/s 	Channel OK No bypass Card health Sensor Signal	Warning flags Gap Overflow
Status flags Test value Standstill Rotation dir.	Status values Speed 2 969 RPM Rotation freq. 49.48 Hz Sens. sig. max. -2.601 V min. 0.000 RPM Acc. 3.312 RPM/s max. 2 978 RPM Sens. sig. min. -4.626 V		

Channel 2: Speed profile (redundant)

Speed 0.000 RPM 	Acceleration 0.000 RPM/s 	Channel OK No bypass Card health Sensor Signal	Warning flags Gap Overflow
Status flags Test value Standstill Rotation dir.	Status values Speed 0.000 RPM Rotation freq. 0.000 Hz Sens. sig. max. -0.003 V min. 0.000 RPM Acc. 0.000 RPM/s max. 0.000 RPM Sens. sig. min. -0.006 V		

Redundancy

Speed DO 1 2 970 RPM 	Limit digital output 1 Suppression	Current suppression Current output 1 Current output 2	Current output 1 18.40 mA
Current output 2 18.40 mA 	Status values Speed 2 970 RPM Acc. 11.78 RPM/s Test value 2 970 RPM Rotation freq. 49.50 Hz		

Service data

Figure 7-46: Service

Service					
Up time	0.1 d	Cold starts	43	Curr. temp.	34.6 °C
Operation time	50.1 d	Ok	28	Min. temp.	20.9 °C
				Max. temp.	37.4 °C

This graphic object contains service data:

- **Up time**
Days in operation since the last power on. This counter is reset at each power on.
- **Operation time**
Days in operation.
- **Cold starts**
Number of cold starts. This counter increments each time the card powers on.
- **Configured**
Number of configurations sent to this card.
- **Curr. temp.**
Current temperature measured by the card internal sensor.
- **Min. temp.** and **Max. temp.**
Minimum and maximum temperature measured by the card internal sensor.

Status values

Figure 7-47: Status values

Status values					
Speed	2 966 RPM	Test value	2 966 RPM	Sens. sig. min.	-4.626 V
min.	0.000 RPM	Rotation freq.	49.43 Hz	Sens. sig. max.	-2.602 V
max.	2 978 RPM	Acc.	-4.023 RPM _r		

This graphic object contains several measurement and signal information.

- **Speed [RPM]**
Currently measured speed.
- **min. [RPM]**
Measured minimum speed. Use the buttons **Reset min/max measurement 1** for channel 1 or **Reset min/max measurement 2** for channel 2 in the ribbon command bar to reset this value.

- **max. [RPM]**
Measured maximum speed. Use the buttons **Reset min/max measurement 1** for channel 1 or **Reset min/max measurement 2** for channel 2 in the ribbon command bar to reset this value.
- **Rotation frequency**
 - Currently measured rotation frequency.
- **Acc. [RPM/s]**
Currently measured acceleration value.
- **Sens. sig. min. [V]**
Measured minimum sensor signal.
- **Sens. sig. max. [V]**
Measured maximum sensor signal.
Both defined trigger threshold limits must be within these minimum and maximum sensor signals if on configuration page **Measurement** the parameter **Input mode** has been set to **Static (slow)**.

Analog Output

Figure 7-48: Current output

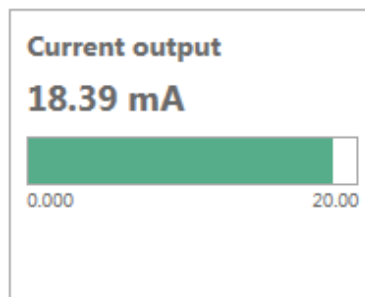

This graphics object shows the current value of the current output.

Next trigger values

Figure 7-49: Next trigger values

Next trigger values	
Inc. trigger	2 906.4 RPM
Dec. trigger	2 806.4 RPM

This object indicates the next trigger values in positive (Inc. trigger) and negative (Dec. trigger) direction used to trigger assigned collection tasks. The trigger values are displayed with one decimal digit to be as precise as possible, as the values could be slightly different to the expected values based on the configured speed delta.

7.2.3 Live data

The page **Live data** shows speed trend, time waveform, frequency spectrum, and phase for channel 1 and channel 2 (if used). See [Figure 7-50](#).

See [Table 7-3](#) for description of the control elements.

Figure 7-50: Live data - speed application



Note

Time data cannot be read through the USB interface. That means live data of the A6500-UM card cannot be displayed if the card is connected through the USB interface.

7.3 Online commands

After an A6500-UM card is configured and operating, you can issue commands to the card from the online view. The commands that are available depend on the card's configuration. In AMS Machine Studio, when the online view of an A6500-UM card is open, the ribbon displays options specific to the Universal Measurement Card. For description of

all other buttons of the ribbon command bar see operating manual "AMS Machine Studio - General Functions" (MHM-97879).

Note

The usage of commands requires an online connection to the card.

- See [Static and dynamic measurement applications](#) for commands related to static and dynamic measurements.
- See [Speed applications](#) for commands related to speed applications.

7.3.1 Static and dynamic measurement applications

In AMS Machine Studio the following commands are available for an Universal Measurement Card configured for static and dynamic applications. [Figure 7-51](#) shows the available command buttons.

Figure 7-51: Command buttons – static and dynamic applications

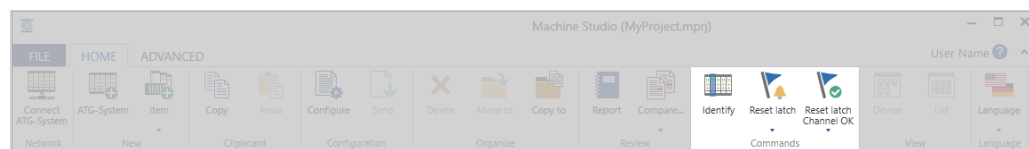

Identify

Figure 7-52: Identify



Click **Identify** to identify the card within the rack. This command starts a LED sequence on the front plate of the card. It runs for approximately 15 seconds and stops automatically.

Reset latch

Figure 7-53: Reset latch

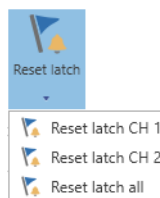

Click **Reset latch** to open a selection list with different options for resetting latched alarms:

- **Reset latch CH 1**
Click this option to reset latched alarms of channel 1.
- **Reset latch CH 2**

Click this option to reset latched alarms of channel 2..

- **Reset latch all**

Click this option to reset all latched alarms at once.

Reset latch – Channel OK

Figure 7-54: Reset latch – Channel OK

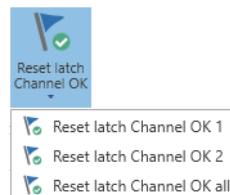

Click **Reset latch Channel OK** to open a list with options for resetting latched Channel not OK states:

- **Reset latch Channel OK 1**

Click **Reset latch Channel OK 1** to reset the latched Channel not OK state of channel 1.

- **Reset latch Channel OK 2**

Click **Reset latch Channel OK 2** to reset the latched Channel not OK state of channel 2.

- **Reset latch Channel OK all**

Click **Reset latch Channel OK all** to reset all latched Channel not OK states at once.

7.3.2 Speed applications

In AMS Machine Studio, the following commands are available only for a Universal Measurement Card configured for speed applications. [Figure 7-55](#) shows the available command buttons for the speed measurement applications.

Figure 7-55: Command buttons – speed application

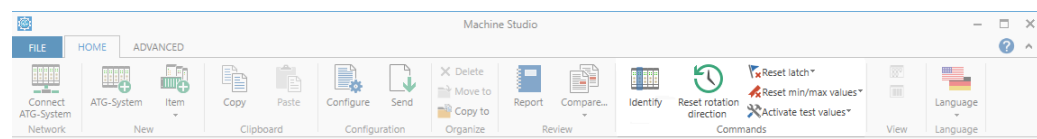

Identify

Figure 7-56: Identify



Click **Identify** to identify the card within the rack. This command starts a LED sequence on the front plate of the card. It runs for approximately 15 seconds and stops automatically.

Reset latch

Figure 7-57: Reset latch



Click **Reset latch** to open a selection list with commands for selective reset of the digital output 1, 2 and 4, 5. The command **Reset latch all** resets all latched outputs at once.

Reset min/max values

Figure 7-58: Reset min/max values

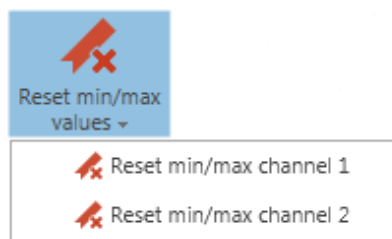

Click **Reset min/max values** to open a selection list with commands for channel selective reset of stored minimum or maximum values. This command resets the following status values:

- Minimum measured speed
- Maximum measured speed
- Minimum measures sensor signal
- Maximum measured sensor signal

Activate test values

Figure 7-59: Activate test

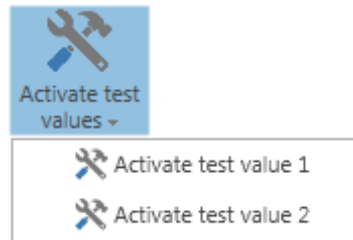

Click **Activate test values** to open a selection list with commands for channel selective activation of configured test values. See configuration page **Measurement** for test values.

Deactivate test values

Figure 7-60: Deactivate test values

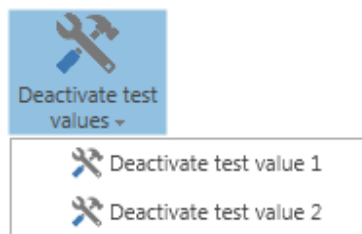

Click **Deactivate test values** to open a selection list with commands for channel selective deactivation of configured test values.

Reset rotation direction

Figure 7-61: Reset rotation direction



Click **Reset rotation direction** to set the current indication to the configured state (see parameter **Reset rotation direction** on page **Measurement**).

8 Functions

8.1 Channel OK supervision

The condition supervision function checks the functionality of card and input signals. This function ensures that invalid measurements are indicated and, if necessary, alarms are deactivated. The indication takes place through:

- One digital output per card channel.
- One green OK LED per channel on the front plate.
- Setting the current output to 0 mA, provided that the corresponding current output is configured for current output range of 4 to 20 mA and current suppression has been activated.
- Modbus and OPC UA interfaces
- Online view of the card in AMS Machine Studio.

Functional disturbances are divided into two groups. Disturbances that affect the monitor are allocated to the group of card errors. Measuring chain disturbances are allocated to the group of channel errors.

Card errors:

- Firmware errors
- Internal card errors
- Exceeding temperature danger limit

Channel errors:

- Sensor errors
- Signal errors (overload of the signal input)

The detection of the sensor status by the channel OK supervision depends on the connected and configured sensor type.

Overload

An overload error is indicated if the input amplifier is overdriven. In that case, the amplitude of the dynamic input signal (AC portion of the signal) exceeds the permissible input range of the signal input (see [Figure 8-1](#)). If the amplitude of the dynamic signal returns to the permissible range, after a waiting time (approximately 15 seconds), the overload message (online view: "Signal" indication in box "Channel OK") will be reset.

Figure 8-1: Diagram overload

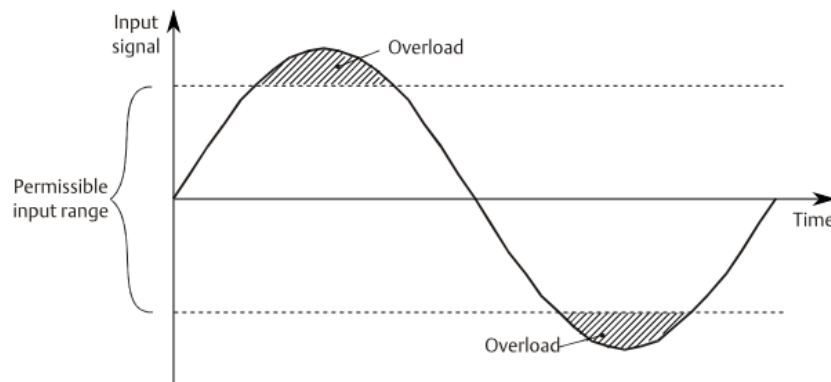

The permissible range depends on the configured sensor. [Table 8-1](#) shows these ranges.

Table 8-1: Permissible dynamic input range

Sensor	Permissible AC voltage range [V peak-to-peak]
Eddy current sensor with CON 011, CON 021, CON 031, or CON 041	10.0
Seismic sensor (PR 9268/ ...)	10.0
Piezoelectric sensor (PR 9270-Ex, PR 9270V-Ex, PR 9272 HT, or other ICP® types)	10.0
Low frequency seismic sensor LF-24	8.0
Low frequency seismic sensor JVP-05-08	10.0
Dynamic pressure sensor CP 103 with IPC 704 and GSI 127 (voltage input – pressure)	10.0
Static pressure sensor	9.0

Channel OK LEDs

Table 8-2: Channel OK LEDs

Status Channel OK LEDs	Card based (both channels)			Channel based		
	Description	Current output 4 to 20 mA and suppression	Digital output	Description	Current output 4 to 20 mA and suppression	Digital output
Off ¹	Card error ²	0 mA	Disabled	Channel error ³	0 mA	Disabled
	Temperature danger ²	0 mA	Disabled	Overload	No influence	Disabled
Steady light	OK status	No influence	Conductive	OK status	No influence	Conductive
Slow flashing ¹	Normal start phase	0 mA	Disabled	Wait after channel error ³	0 mA	Disabled

Table 8-2: Channel OK LEDs *(continued)*

Status Channel OK LEDs	Card based (both channels)			Channel based		
	Description	Current output 4 to 20 mA and suppression	Digital output	Description	Current output 4 to 20 mA and suppression	Digital output
				Wait after overload	No influence	Disabled
Fast flashing ¹	Temperature alert	No influence	Conductive			
	Wait after card error ³	0 mA	Disabled			
Alternate flashing	Card not configured	0 mA	Disabled			

¹ More precise information concerning the cause is available in the online view.

² Alert and danger are suppressed (initial state of the alarm outputs).

³ If limit suppression is active, then the alarm outputs (alert and danger) are in their initial state.

Note

Alternate flashing of the alarm LEDs indicates that the card is in the boot loader. If the card sticks in this condition - still alternate flashing for longer than 10 seconds set the card to the factory default (see [Ribbon command bar](#)) and configure the card anew.

Influence on combined channel measurements if one channel fails.

- Channel OK LED of the failed channel is switched off.
- Digital output assigned to Channel OK is switched.
- The alarm outputs are switched to their initial state if "limit suppression" has been activated.
- The current outputs are set to 0 mA if the current output is configured for output range of 4 to 20 mA and current suppression has been activated.

Latching of Channel OK

The Channel not OK state can be latched. Activate latching for each input channel separately, see [Channel OK latching](#). With latching activated, the Channel not OK state, independently of the cause for the Channel not OK, is latched unless the state is reset. Channel not OK during the normal start phase of the card is not latched. A latched Channel not OK state can be reset as soon as the condition for Channel not OK is no longer present. Use one of the following interfaces for the reset:

- Digital inputs (see [Digital inputs](#))
- AMS Machine Studio (see [Online commands](#))

The Channel OK state depends on the configuration of the card. [Table 8-3](#) shows the Channel OK state depending on:

- Settings for **Channel OK latching**
- Settings for **Bypass affects Channel OK**

- Channel errors (signal or sensor errors)

Table 8-3: Channel OK state depending on channel errors and bypass settings

Settings		Channel OK state							
		Channel error				No channel error			
Channel OK Latching	Bypass affects Channel OK	During reboot / delay	After reboot / running	Bypass active	Bypass reset	During reboot / delay	After reboot / running	Bypass active	Bypass reset
Off	On	Off	Off	Off	Off	Off	On	Off	On
On	On	Off	Off	Off	Off (Latched)	Off	On	Off	Off (Latched)
Off	Off	Off	Off	Off	Off	Off	On	On	On
On	Off	Off	Off	Off	Off (Latched)	Off	On	On	On

8.1.1 Eddy current measuring chains and A6500-LC

The DC part of the channel's input voltage is monitored. If the input voltage exceeds the upper value specified for the converter operating range by +0.5 V or if it falls below the lower value by -0.5 V, a channel error message is generated (see Figure 8-2). If the input voltage returns to the good range the channel error message is reset after a wait time of approximately 15 seconds.

Figure 8-2: Diagram sensor supervision - example range -2 to -18 V

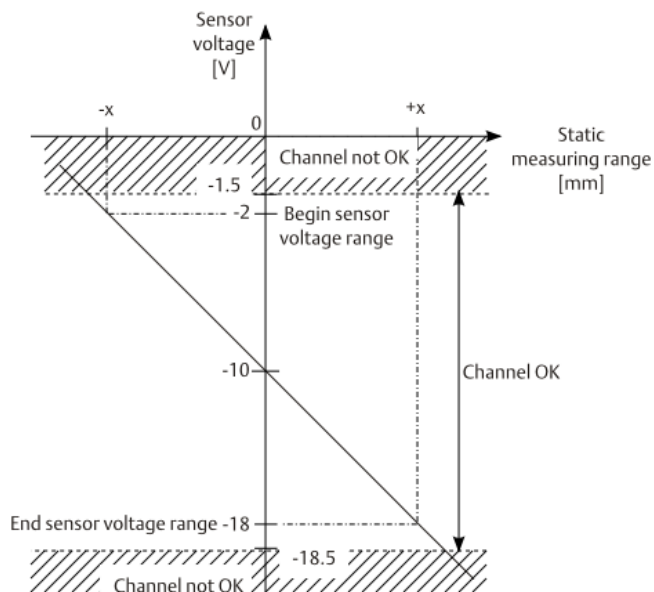

8.1.2 Piezoelectric sensors

The signal input voltage range of the measurement circuit is monitored. If the measured voltage is higher than 23.0 V or lower than 1.0 V, a channel error is generated (see [Figure 8-3](#)). If the measured voltage value returns to the good range, the channel error message is reset after a waiting time of approximately 15 seconds.

Figure 8-3: Diagram piezoelectric sensor supervision

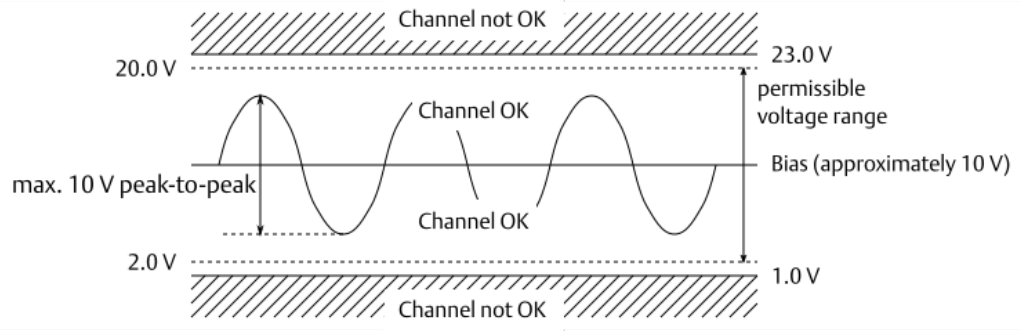

8.1.3 Seismic sensors

The signal input voltage range of the measurement circuit is monitored. If the measured voltage is higher than +15 V or lower than -10 V a channel error is generated (see [Figure 8-4](#)). If the measured voltage value returns to the good range, the channel error message is reset after a waiting time of approximately 15 seconds.

Figure 8-4: Diagram seismic sensor supervision

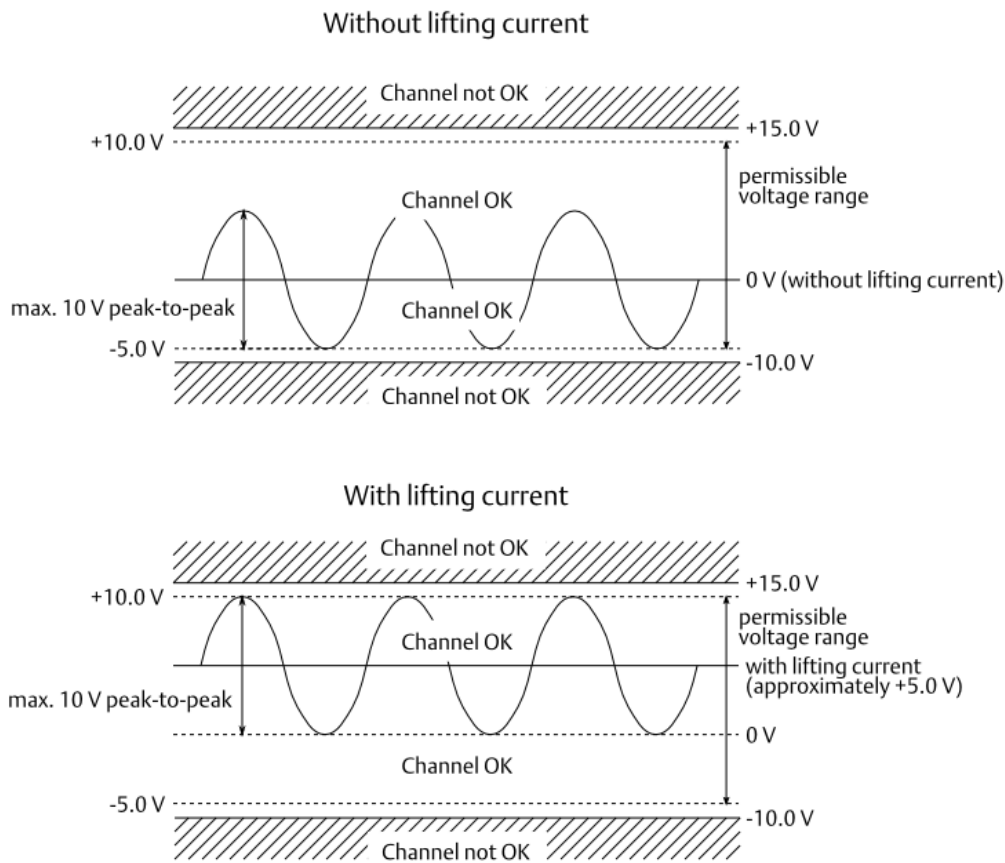

8.1.4 Bearing vibration sensors LF-24 and JVP-05-08

The signal input voltage range of the measurement circuit is monitored. If the measured voltage is higher than +11.0 V or lower than -11.0 V, a channel error is generated (see [Figure 8-5](#)). If the measured voltage value returns to the good range, the channel error message is reset after a waiting time of approximately 15 seconds.

Figure 8-5: Diagram LF-24 and JVP-05-06 supervision

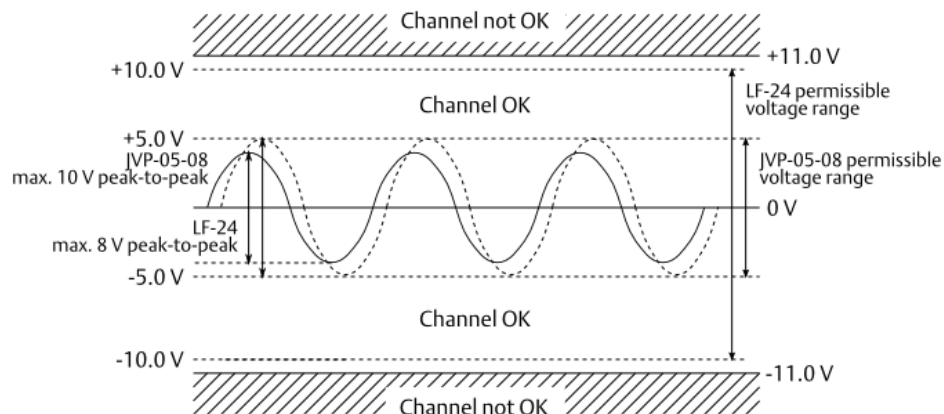

8.1.5 Dynamic pressure sensor CP 103 with IPC 704 and GSI 127 (voltage input – pressure)

The DC and AC part of the signal voltage of the measurement circuit is monitored. If the DC part of the measured voltage is higher than +8.5 V or lower than +5.5 V or the AC part of the signal voltage is higher than 10.0 V peak-to-peak, a channel error is generated (see Figure 8-6). If the measured voltage returns to the good range, the channel error message is reset after a waiting time of approximately 15 seconds. The permissible voltage range for the input signal is 2.0 to 20.0 V.

Figure 8-6: Diagram dynamic pressure sensor supervision

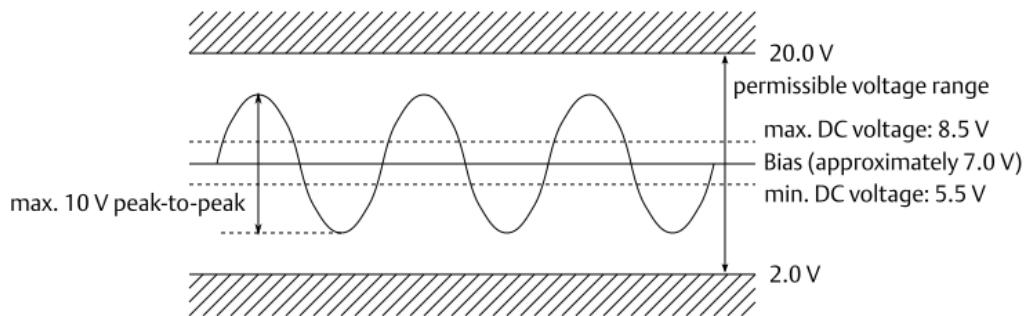

8.1.6 Hall-effect sensor PR 9376 with load resistors

The channel OK supervision of PR 9376 Hall-effect sensors require additional load resistors. See [Input 1 and Input 2](#), parameter **Load resistor** for details. Because of the load resistors the channel OK supervision can detect an open sensor input, caused, for example, by a broken sensor cable or a not connected sensor. Short circuits in the sensor wiring cannot be detected.

The signal input voltage range of the measurement circuit is monitored.

- Channel OK is switched off if the input voltage is within the range of 5.0 V to 18.5 V.

- Channel OK is switched on if the input voltage is out of the range of 5.0 V to 18.5 V.

If the measured voltage returns to the good range, the channel error message is reset after a waiting time of approximately 15 seconds.

Figure 8-7: Diagram PR 9376 supervision

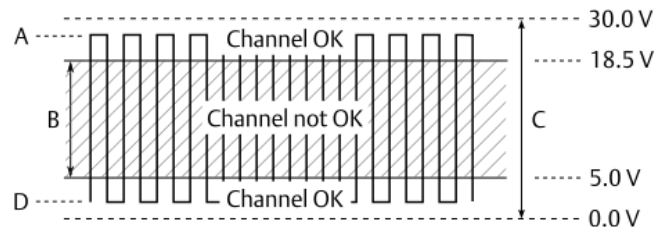

- A. Approximately 27.0 V; PR 9376 with load resistors faces a gap
- B. Channel not OK range: 5.0 V to 18.5 V
- C. Sensor supply voltage range: 0 V to 30 V
- D. Approximately 2.0 V; PR 9376 with load resistors faces a tooth

8.1.7 VR sensors

The channel supervision of VR sensors checks whether a VR sensor is connected or not by using a low sensing current⁵.

Custom VR sensor

The default sensing current may be too low for an accurate channel OK supervision of a connected VR sensor with an impedance of less than 150 Ω.

Activate **Increase sensing current** in the components database entry to stabilize the Channel OK supervision.

Increasing of the sensing current is available for VR sensors manually added to the components database.

8.1.8 Static pressure sensors – Bently Nevada 165855

The DC and AC part of the signal voltage is monitored. If the DC part of the measured voltage is higher than 10.5 V or lower than 0.4 V, a channel error is generated (see [Figure 8-8](#)). If the measured voltage returns to the good range, the channel error message is reset after a waiting time of approximately 15 seconds.

Add a 20 kΩ resistor to the sensor signal input to detect an open signal circuit. See operation manual A6500-xR System Racks for details.

⁵ Requires an A6500-UM card with hardware revision 08 or higher. No Channel OK supervision with hardware revisions lower than 08 – the supervision function continuously indicates Channel OK.

Figure 8-8: Diagram static pressure sensor supervision

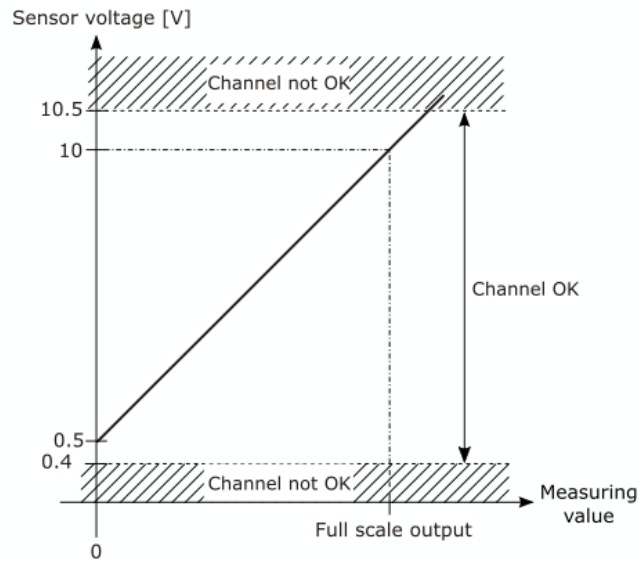

8.2 Current outputs

Depending on the configuration, the two analog outputs supply currents between 0 to 20 mA or 4 to 20 mA scaled on the configured measuring range. Figure 8-9 shows the current output depending on the configured measuring range. For current output range 4 to 20 mA, you can set the current, in case of fault, to 0 mA (current suppression).

Figure 8-9: Current output diagram

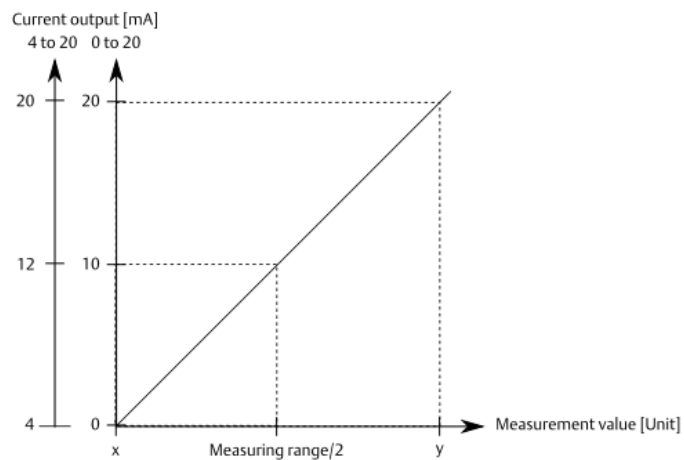

8.3 Digital in- and outputs

Digital inputs

The Universal Measurement Card has five low-active digital inputs.

Depending on the configured measurement mode, the functions listed in [Table 8-4](#) can be assigned to the inputs.

Table 8-4: Digital input functions

Measurement mode	
Dynamic and Static	Speed
Reset latch out 1 (both outputs of channel 1)	Identify
Reset latch out 2 (both outputs of channel 2)	Bypass
Reset latch all	Bypass DO 1-2
Identify	Bypass DO 4-5
Bypass	Reset min max measurement 1
Bypass DO 1-2 ¹	Reset min max measurement 2
Bypass DO 4-5	Reset rotational direction
Limit level multiplier	Activate test value 1
Key (only input DIN1 or input DIN2)	Activate test value 2
Operation mode	Reset latch DO 1
Event trigger	Reset latch DO 2
	Reset latch DO 4
	Reset latch DO 5
	Event trigger

¹ DO: Digital Output

Low-active: A function, assigned to the respective digital input is active if the input is switched to ground (GND). The function is not active if the input is open or switched to +24V DC.

For wiring and further information, see the A6500-xR System Racks operating manual.

Digital outputs

The Universal Measurement Card has six galvanically separated digital outputs - three per channel. One output per channel is assigned to the Channel OK supervision. The operation principle (open-circuit mode or closed-circuit mode), except of the Channel OK outputs, is changeable by the parameter **Circuit mode** on configuration page **Digital output**. The function of the remaining outputs depends on the configured measurement mode (see [Table 8-5](#)).

Table 8-5: Digital output functions

Digital output	Measurement mode		
	Dynamic	Static	Speed
Out 1	Danger channel 1	Positive or negative danger channel 1	\geq Limit channel 1 \geq Limit channel 2
Out 2	Alert channel 1	Positive or negative alert channel 1	\geq Limit latch channel 1 \geq Limit latch channel 2 \leq Limit channel 1 \leq Limit channel 2 \leq Limit latch channel 1 \leq Limit latch channel 2 < Limit, no zero speed channel 1 < Limit, no zero speed channel 2 Standstill channel 1 Standstill channel 2 Gap warning channel 1 Gap warning channel 2 Difference channel 1 / channel 2 Rotational direction
Out 3	Channel OK channel 1	Channel OK channel 1	Channel OK channel 1
Out 4	Danger channel 2	Positive or negative danger channel 2	\geq Limit channel 1 \geq Limit channel 2
Out 5	Alert channel 2	Positive or negative alert channel 2	\geq Limit latch channel 1 \geq Limit latch channel 2 \leq Limit channel 1 \leq Limit channel 2 \leq Limit latch channel 1 \leq Limit latch channel 2 < Limit, no zero speed channel 1 < Limit, no zero speed channel 2 Standstill channel 1 Standstill channel 2 Gap warning channel 1 Gap warning channel 2 Difference channel 1 / channel 2 Rotational direction
Out 6	Channel OK channel 2	Channel OK channel 2	Channel OK channel 2

For wiring and further information see A6500-xR System Racks operation manual.

8.4 Sensor raw signal outputs

The sensor signal of each channel is taken directly at the sensor signal input and then connected to the sensor signal connector at the card front (SMB sockets) and through the connector at the card rear to the assigned 9-pole D-Sub connector of the A6500-xR System Rack. Both raw signal outputs, the SMB socket at the card front and the assigned 9-pole D-Sub connector of the System Rack, can be used simultaneously.

- The sensor raw signal outputs are decoupled and reactionless to the sensor signal input but not galvanically separated from it.
- The SMB socket and the connection to the 9-pole D-Sub connector are decoupled from each other but not galvanically separate.

A short circuit at the SMB socket, for example, neither affects the sensor input signal nor the assigned sensor raw signal output of the System Rack.

8.5 Key-signal output / input

An Universal Measurement Card in Speed mode can provide key-signals to, for example, other Universal Measurement Cards or prediction systems. Each channel of a card in Speed mode can provide a key signal.

For wiring and further information see the A6500-xR System Racks operation manual.

8.6 Trigger threshold limit detection

Only necessary if you have chosen **Static (slow)** for parameter **Input mode**.

There are two possibilities for defining the trigger threshold limits:

8.6.1 Manual limit definition

You need an oscilloscope for the manual definition of the trigger thresholds.

1. Measure with the oscilloscope at low machine speed (turning gear operation) the input signal preferably at the sensor signal sockets at the card front or at the output terminals of the eddy current converter, of the Hall-effect sensor, or VR sensor.
2. Note the measured signal amplitude and, for eddy current sensors also the DC level which refers to the sensor adjustment. Use the following formulas to calculate the threshold limits.

Eddy current sensor

Use these formulas if the sensor signal is negative and contains a DC offset.

$$UTT = \frac{-3 * U_{Amplitude}}{8} + U_{Adjust}$$

$$LTT = \frac{-5 * U_{Amplitude}}{8} + U_{Adjust}$$

Hall-effect sensor or VR sensor

Use these formulas if the sensor signal is positive and does not contain a DC offset.

$$LTT = \frac{3 * U_{Amplitude}}{8}$$

$$UTT = \frac{5 * U_{Amplitude}}{8}$$

Hall-effect sensor with DC offset

Use these formulas if the sensor signal is positive and contains a DC offset.

$$LTT = \frac{3 * U_{Amplitude}}{8} + U_{Adjust}$$

$$UTT = \frac{5 * U_{Amplitude}}{8} + U_{Adjust}$$

UTT = upper trigger threshold

LTT = lower trigger threshold

$U_{Amplitude}$ = amplitude of the input signal (peak-to-peak)

U_{Adjust} = sensor adjustment level over a tooth (DC offset)

Experience has shown that values 3/8 and 5/8 of the signal amplitude provide suitable trigger thresholds.

3. Enter the calculated thresholds into the corresponding field ("Upper trigger threshold limit [V]" and "Lower trigger threshold [V]").
4. Send the configuration into the card.

8.6.2 Automatic limit detection

Prerequisite:

- The machine must be in turning gear mode (at low speed)
- Online connection between configuration software and Universal Measurement Card
- Connected eddy current sensor or VR sensor

1. Click **Set** behind the input field of parameter "Upper trigger threshold limit [V]". Both threshold limits will be detected automatically and entered into the input fields.

Note

The voltage level difference between the minimum and maximum input signal voltage must be higher than 2 V otherwise the automatic threshold limit detection will not work.

2. Send the configuration to the card.

8.7 Acceleration measurement

The A6500-UM measures the rotational acceleration in [RPM/s]. The measured acceleration can be supervised on limit exceeding. [Figure 8-10](#) shows a diagram of the acceleration measurement. In this diagram, Speed 1 changes to the new value Speed 2.

The red, broken line shows the speed change (ΔSpeed) within a shorter time (Δt_2) with a higher acceleration as the black solid line (Δt_1). With this speed course, it takes more time to reach Speed 2, which means lower acceleration.

Figure 8-10: Diagram acceleration measurement

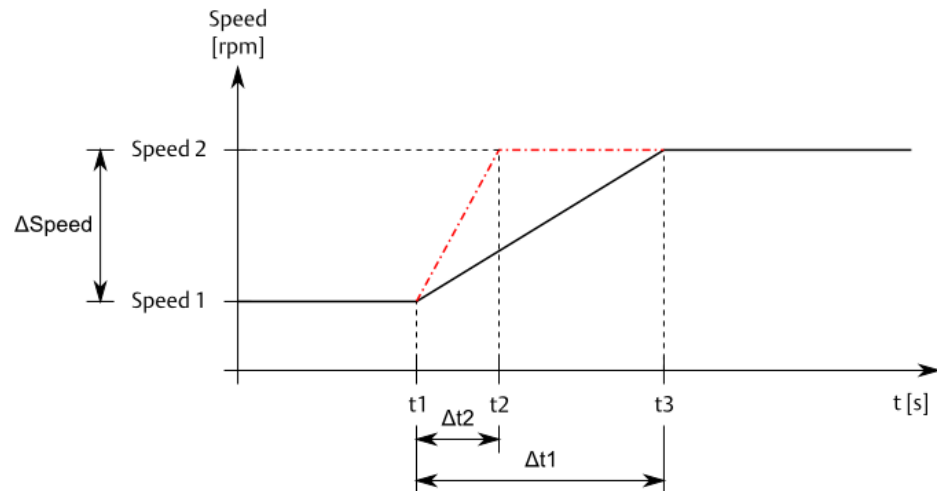

8.8 Peak and Phase

Use this function to supervise peak and phase of two selectable harmonics for each channel. The required order analysis for calculation of peak and phase is made by the integrated analysis function of the Universal Measurement Card. Define alarm limits for the supervision of the peak and phase values.

Conditions for Phase and Peak measurement

- Ensure that a Key-signal is available (for example, provided by a A6500-UM Universal Measurement Card in Speed mode).
- Activate the order analysis function (configuration page **Analysis**, choose **Order Analysis including PeakPhase** for parameter **Selected analysis**).
- The amplitude for the peak alarm is always in 0 - peak regardless of the selected signal evaluation (configuration page **Measurement**, parameter **Evaluation**).
- The peak and phase alarming will only be active if the machine speed is at normal speed \pm speed tolerance. If the machine speed is outside these limits, the alarming function will be disabled. (configuration page **Measurement**, parameter **Nominal speed** and optional parameter **Speed tolerance**).

Phase baseline definition for phase alarms

The phase alarm function supervises a phase deviation from a phase baseline. This phase baseline is the phase (α) of the vibration vector (A) at normal machine conditions (normal speed). A fault event can change the phase of the vibration vector without considerable change of the amplitude (see vector B on [Figure 8-11](#)).

Figure 8-11: Change vector

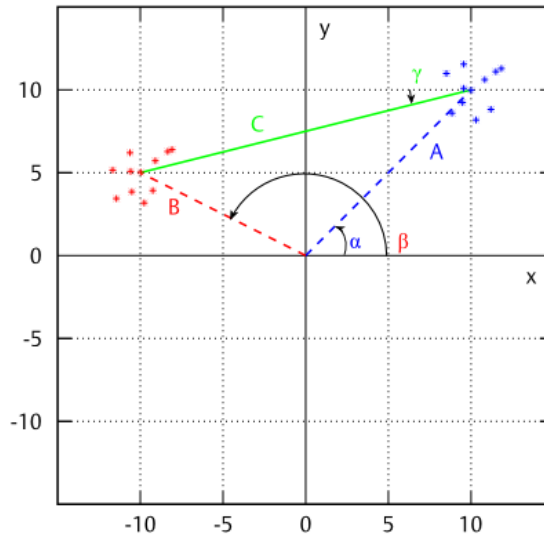

- A. Baseline (initial vibration vector at normal machine condition)
- B. Machine vibration vector after a fault event
- C. Change vector

Prerequisite:

- The machine must running at nominal speed.
- A key-signal is required.
- The Universal Measuring Card is configured for Peak Phase.
- Online connection between AMS Machine Studio and the Universal Measurement Card.
 1. Click **M** behind the parameter **Phase Baseline 1 [°]** or **Phase Baseline 2 [°]**.
AMS Machine Studio detects the current phase and copies it to the **Phase Baseline** filed (see [Figure 8-12](#)).
 2. Send the configuration to the card.

Figure 8-12: Parameter "Phase baseline"

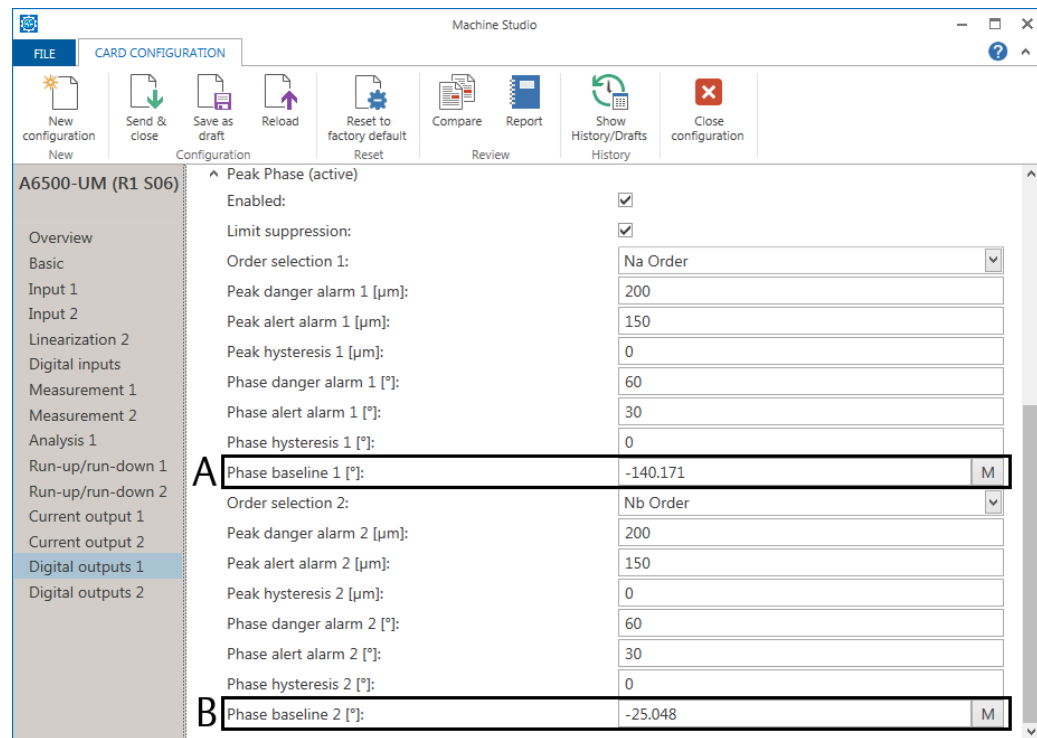

- A. Parameter **Phase baseline 1** for the first selected order.
- B. Parameter **Phase baseline 2** for the second selected order.

8.9 PeakVue

PeakVue (Peak values) is a method to detect impact-like events such as bearing defects. This function can be activated for bearing vibration measurements.

PeakVue performs a kind of oversampling of the AC part of the sensor raw signal within a defined frequency range. Besides the DC filtering, the AC part of the sensor signal is unaffected. This sampling process generates a PeakVue waveform that can be displayed on the online view in AMS Machine Studio or read through the Modbus communication. The detected amplitudes can be supervised by configurable alert alarm and danger alarm limits.

The PeakVue time waveform can be displayed instead of the general time waveform in the online view (see [Analysis 1](#) and [Analysis 2](#), parameter **Show PeakVue Live Data**).

8.10 Recording of run-ups or run-downs

The function records the measurement value over the speed. A run-up is registered, if the minimum speed limit, parameter **Speed limit min** defined on configuration page **Run-up / run-down**, was exceeded, and then (without time limit) the maximum speed limit, parameter **Speed limit max**. For a run-down, these values must be underrun in reverse

direction (Figure 8-13). Only the last completed run-up or run-down values are stored and displayed on the Live Data page of the online view. AMS Machine Studio discards run-ups or run-downs that were started but interrupted.

Figure 8-13: Diagram run-up and run-down

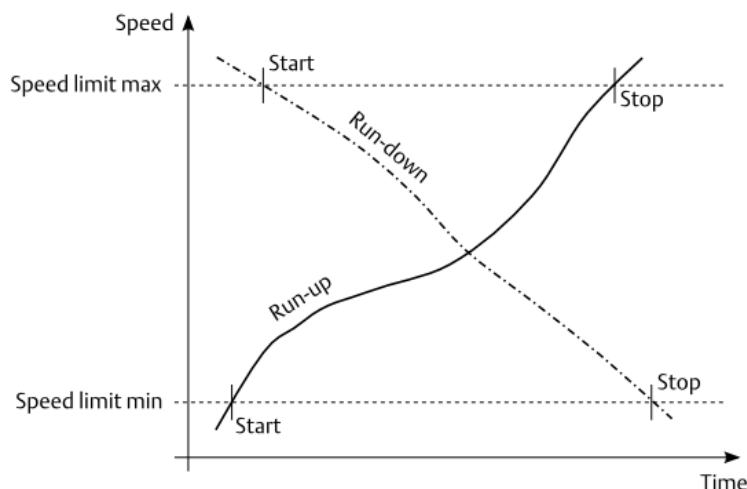

8.11 Bypass

The four digital outputs DO 1, DO 2, DO 4, and DO 5 of the A6500-UM card can be bypassed. Different interfaces are available to activate a bypass:

- Digital inputs (see [Digital inputs](#))
- Software inputs (Modbus and OPC UA, see [Digital inputs](#))
- AMS Machine Studio (see [Bypass – online commands](#))

⚠ DANGER

Bypassed digital outputs are not part of the machine protection.

The source of the bypass activation is displayed in the online view of AMS Machine Studio if the bypassed card is selected.

Figure 8-14: Notification about an active bypass

⚠ Bypass DO 1-2 enabled by Machine Studio - digital outputs 1 and 2 will not be triggered!
 Bypass DO 1-2 affects Channel OK of CH 1
 Suppression active - digital and analog outputs may be affected!

With an activated bypass the related outputs are switched to their initial state. The initial state depends on the configured operation principle (normally open- or normally closed-circuit mode) of the digital outputs.

Whether the Channel OK outputs (digital output 3 or digital output 6) are affected or not depends on the configuration of the digital outputs 3 and 6 (see [Input 1 and Input 2](#),

Bypass ... affects ...). All functions related to Channel OK such as current suppression (**Current output** → **Current suppression**) react accordingly.

The bypass activation with AMS Machine Studio is prioritized over the digital inputs and the software inputs.

The alarm states provided through the Modbus or OPC UA interface are also affected by the bypass. The online display of the measuring value is grayed out but still indicating the current value. An active bypass is indicated by:

- Modbus registers and OPC UA data points:

Table 8-6: Bypass indication

Function	Modbus register	OPC UA data point
Bypass DO 1-2 or Bypass ¹	BypassCH1	
Bypass DO 4-5	BypassCH2	

¹ Applications with calculation based on two channels

- Online display
 - Channel OK LEDs
- If **Bypass ... affects CH ... - Channel OK** is activated.

Table 8-7 shows the influence of an activated bypass on the digital outputs and the LEDs of the card front.

Table 8-7: Overview bypass influence

Bypass active	Digital outputs				LEDs	
	1 and 2	3	4 and 5	6	OK	Alarm
Bypass DO 1-2 and COK Bypassed ¹	Initial state	Open	No influence	No influence	Off	Off
Bypass DO 1-2 ²	Initial state	Closed	No influence	No influence	On	Off
Bypass DO 4-5 and COK Bypassed ¹	No influence	No influence	Initial state	Open	Off	Off
Bypass DO 4-5 ²	No influence	No influence	Initial state	Closed	On	Off
Bypass all DOs and COK Bypassed ¹	Initial state	Open	Initial state	Open	Off	Off
Bypass all DOs ²	Initial state	Closed	Initial state	Closed	On	Off

¹ Input → **Bypass DO ... affects CH ... - Channel OK** activated

² Input → **Bypass DO ... affects CH ... - Channel OK** not activated

Bypass – online commands

Control the bypass function through AMS Machine Studio.

1. Ensure that there is an online connection to the AMS 6500 ATG system.
2. Select the A6500-UM Universal Card to be bypassed from the device tree.
3. Press **Ctrl+Alt+M** to enable the maintenance mode.
The bypass buttons appear.
4. With single channel applications click **Bypass DO 1-2** or **Bypass DO 4-5** to open options to control the bypass of the digital outputs per channel. With combined channel applications click **Bypass** to control the bypass of all digital outputs. These settings overwrite digital inputs configured to activated bypass and software switches (Modbus and OPC UA) assigned to the bypass function.

Figure 8-15: Bypass control

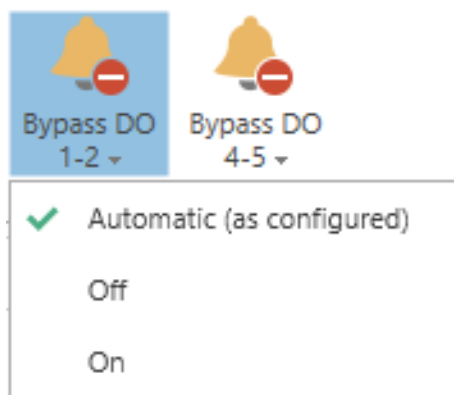

Automatic (as configured)	The bypass function works as configured. Default setting.
Off	The bypass for the digital outputs 1 and 2 (button Bypass DO 1-2), 4 and 5 (button Bypass DO 4-5) or all digital outputs (button Bypass) is not active.
On	The bypass for the digital outputs 1 and 2, 4 and 5, or 1, 2, 4, and 5 is active.

9 Applications

9.1 Single-channel applications

9.1.1 Single-channel – shaft vibration

In this mode, both channels of the A6500-UM Universal Measurement Card are operating independently of each other. One or both channels of the card can be used to measure relative shaft vibration. See [Table 9-1](#) for signal evaluation details ("µm" is used for the following example).

Table 9-1: Signal evaluation

Sensor type	Signal evaluation	Unit	Description
Eddy current	0-to-peak	µm or mil	Measurement value is proportional to shaft vibration displacement in 0-to-peak evaluation
	peak-to-peak		Measurement value is proportional to shaft vibration displacement in peak-to-peak evaluation
	RMS ¹		Measurement value is proportional to shaft vibration displacement in RMS ¹ evaluation

¹ Root Mean Square

[Figure 9-1](#) shows a sensor arrangement example with an eddy current sensor mounted into the bearing to measure the vibration of the shaft in radial direction.

Figure 9-1: Sensor arrangement example – single-channel shaft vibration

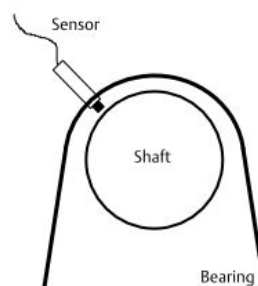

Sensor adjustment

Emerson recommends eddy current measuring chains consisting of the listed sensors and converters (see [Table 9-2](#)).

Table 9-2: Recommended sensors and converter

Sensors and converters
Sensors

Table 9-2: Recommended sensors and converter (continued)

Sensors and converters
EZ 105x-xx-xx-xxx ¹
EZ 108x-xx-xx-xxx ¹
PR 6422/xxx-xxx ¹
PR 6423/xxx-xxx ¹
PR 6424/xxx-xxx
PR 6425/xxx-xxx
Converters
EZ 1000
CON 011
CON 021
CON 031
CON 041

¹ Standard for shaft vibration measurement

The sensor must be set to the center of its static measuring range by measuring the converter output voltage.

Note

When adjusting the center position, consider the lifting of the shaft caused by the oil film thickness. Applies to machines with sleeve bearings.

1. Switch on the power supply of the A6500-xR System Rack in which the Universal Measurement Card is installed.
2. Measure the output voltage of the measuring chain on the terminals OUT and ⊥ (GND) on the converter with a DC voltmeter.
3. Adjust the distance between sensor and shaft so that the measured converter output voltage is in the center of the voltage range (for example, -2 ... -18 V) approximately -10 V.
4. Fix the sensor in that position.

See operation manual of the used sensor for further installation details.

Card configuration

Note

See [General configuration procedure](#) for description of the general configuration process.

The measured vibration value can be supervised on limit violation and output through:

- Current outputs.
- Modbus communication of the A6500-CC Com Card.
- OPC UA communication of the A6500-CC Com Card.

Digital alarm outputs can be used for indication of limit violation.

Select the appropriate application from the "New Configuration window".

1. Click **Two separate channels** to open the two channel application list.
2. Select **Relative shaft vibration** for the appropriate channel.
3. Enter the parameters.

See [Table 9-3](#) for an example configuration of a single channel shaft vibration measurement with an eddy current measuring chain consisting of a PR 6423/xxx-xxx and a CON 011 with converter output voltage range -2 to -18 V. Only significant parameters are listed.

Table 9-3: Shaft vibration – example configuration

Configuration page	Parameter	Value
Input 1	Sensor	PR 6423
	Converter	CON 011 -2/-18 V
Measurement 1	Tacho	Key 1
	Evaluation	Displacement P-P
	Measuring range [μm]	125
	Nominal speed [RPM]	3000
Current output 1	Current output	4 - 20 mA
	Current suppression ¹	Box checked
Alarm limits 1	Enabled	Box checked
	Danger alarm [μm]	110
	Alert alarm [μm]	95
	Alarm hysteresis [μm]	5
	Latching	Box not checked
	Limit suppression	Box checked

¹ Optional Parameter

4. Click **Send & close** to send the configuration to the card.

9.1.2 Single-channel – case vibration with seismic sensors

In this mode, both channels of the A6500-UM Universal Measurement Card are operating independently of each other. One or both channels of the card can be used to measure absolute case vibration with seismic sensors. The unit depends on sensor type and signal integration (see [Table 9-4](#)). Metric units are used for the following example.

Table 9-4: Signal evaluation

Sensor type	Signal evaluation	Signal integration	Unit	Description
Seismic (electro dynamic)	Velocity RMS	inactive	mm/s or inch/s	Measurement value is proportional to case vibration velocity
	Velocity 0-to-peak			
	Velocity peak-to-peak			
	Displacement RMS	active	μm or mil	Measurement value is proportional to case vibration displacement
	Displacement 0-to-peak			
	Displacement peak-to-peak			

Single-channel – case vibration with seismic sensors shows a sensor arrangement example with a seismic sensor mounted on top of a bearing.

Figure 9-2: Sensor arrangement example – single channel bearing vibration with a seismic sensor

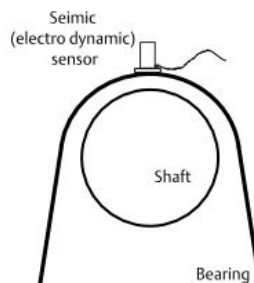

Sensor adjustment

Emerson recommends the listed seismic sensors (see [Table 9-5](#)).

Table 9-5: Seismic sensors

Sensors	Measurement direction
PR 9268/2xx-xxx	vertical
PR 9268/3xx-xxx	horizontal
PR 9268/6xx-xxx	vertical
PR 9268/7xx-xxx	horizontal

The mounting direction depends on the sensor type used. See operation manual of the sensor for further installation details.

Card configuration

Note

See [General configuration procedure](#) for description of the general configuration process.

The measured vibration value can be supervised on limit violation and output through:

- Current outputs.
- Modbus communication of the A6500-CC Com Card.
- OPC UA communication of the A6500-CC Com Card.

Digital alarm outputs can be used for indication of limit violation.

Select the appropriate application from the "New Configuration window".

1. Click **Two separate channels** to open the two channel application list.
2. Select **Absolute bearing vibration** for the appropriate channel.
3. Enter the parameters.

See [Table 9-6](#) for an example configuration of a single channel bearing vibration measurement with the seismic sensor type PR 9268/20x-xxx. Only significant parameters are listed.

Table 9-6: Bearing vibration with seismic sensors - example configuration

Configuration page	Parameter	Value
Input 1	Sensor	PR 9268/200
	Mounting angle [°]	0
	Connection type	2-wire
Measurement 1	Tacho	Key 1
	Evaluation	Displacement P-P
	Measuring range [µm]	200
	Nominal speed [RPM]	3000
Current output 1	Current output	4 - 20 mA
	Current suppression (Optional parameter)	Box checked
Alarm limits 1	Enabled	Box checked
	Danger alarm [µm]	160
	Alert alarm [µm]	120
	Alarm hysteresis [µm]	2
	Latching	Box not checked
	Limit suppression	Box checked

4. Click **Send & close** to send the configuration to the card.

9.1.3 Single-channel – case vibration with piezoelectric sensors

In this mode, both channels of the A6500-UM Universal Measurement Card are operating independently of each other. One or both channels of the card can be used for measurement of the absolute case vibration with piezoelectric sensors. The unit depends on sensor type and signal integration (see [Table 9-7](#)). Metric units are used for the following example.

Table 9-7: Signal evaluation

Sensor type	Signal evaluation	Signal integration	Unit	Description
Acceleration	Acceleration peak-to-peak	inactive	g	Measurement value is proportional to case vibration acceleration
	Acceleration 0-to-peak			
	Acceleration RMS			
	Velocity peak-to-peak	active	mm/s or inch/s	Measurement value is proportional to case vibration velocity
	Velocity 0-to-peak			
	Velocity RMS			
Velocity	Velocity peak-to-peak	inactive	mm/s or inch/s	Measurement value is proportional to case vibration velocity
	Velocity 0-to-peak			
	Velocity RMS			
	Displacement peak-to-peak	active	µm or mil	Measurement value is proportional to case vibration displacement
	Displacement 0-to-peak			
	Displacement RMS			

[Figure 9-3](#) shows a sensor arrangement example with a piezoelectric sensor mounted on top of a bearing.

Figure 9-3: Sensor arrangement example – single channel bearing vibration with a piezoelectric sensor

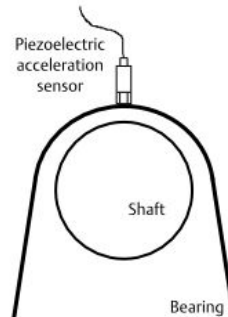

Sensor adjustment

Emerson recommends the listed piezoelectric sensors (see [Table 9-8](#)).

Table 9-8: Piezoelectric sensors

Sensors
A0322
PR 9270-Ex
PR 9270V-Ex

Piezoelectric sensors can be generally mounted in any measurement direction. See operation manual of the sensor used for further installation details.

Card configuration

Note

See [General configuration procedure](#) for description of the general configuration process.

The measured vibration value can be supervised on limit violation and output through:

- Current outputs.
- Modbus communication of the A6500-CC Com Card.
- OPC UA communication of the A6500-CC Com Card.

Digital alarm outputs can be used for indication of limit violation.

Select the appropriate application from the "New Configuration window".

1. Click **Two separate channels** to open the two channel application list.
2. Select **Absolute bearing vibration** for the appropriate channel.
3. Enter the parameters.
See [Table 9-9](#) for an example configuration of a single channel bearing vibration measurement with a piezoelectric acceleration sensor. Only significant parameters are listed.

Table 9-9: Bearing vibration with piezoelectric sensors – example configuration

Configuration page	Parameter	Value
Input 1	Sensor	PR 9270-Ex
	Connection type	2-wire
Measurement 1	Tacho	Key 1
	Evaluation	Acceleration 0-P
	Measuring range [g]	5
	Nominal speed	3000
Current output 1	Current output	4 - 20 mA
	Current suppression ¹	Box checked
Alarm limits 1	Enabled	Box checked
	Danger alarm [g]	3
	Alert alarm [g]	2
	Alarm hysteresis [g]	0.2
	Latching	Box not checked
	Suppression	Box checked

¹ Optional parameter

- Send the configuration to the card. Click **Send & close**.

9.1.4 Single-channel – shaft position

In this mode, both channels of the A6500-UM Universal Measurement Card are operating independently of each other. One or both channels of the card can be used for measurement of the relative shaft position, distance, expansion, and so on in the unit "mm" or "mil" ("mm" is used for the following example).

Figure 9-4 shows a sensor arrangement example with an eddy current sensor measuring the shaft position at a shaft collar.

Figure 9-4: Sensor arrangement example – single-channel position measurement

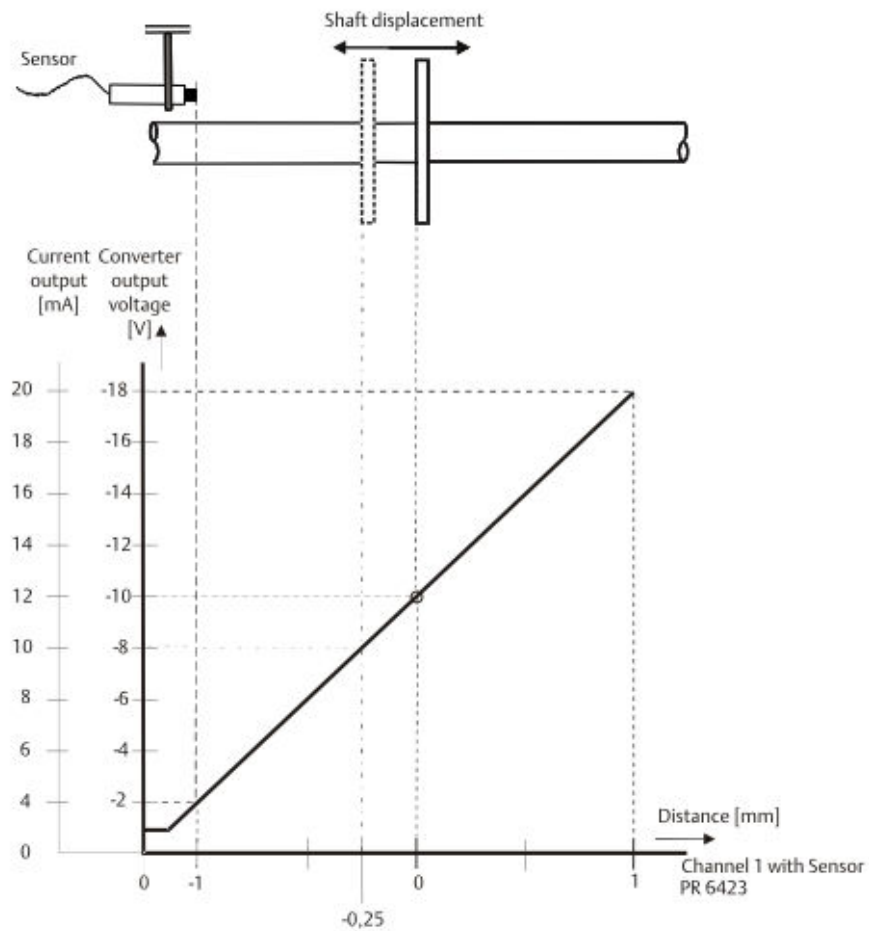

Sensor adjustment

Note

The position of the shaft must be known when adjusting the sensor.

Emerson recommends eddy current measuring chains consisting of the listed sensors and converters (see [Table 9-10](#)).

Table 9-10: Recommended sensors and converters

Sensors and converters
Sensors
EZ 105x-xx-xx-xxx
EZ 108x-xx-xx-xxx
PR 6422/xxx-xxx
PR 6423/xxx-xxx
PR 6424/xxx-xxx

Table 9-10: Recommended sensors and converters (continued)

Sensors and converters
PR 6425/xxx-xxx
PR 6426/xxx-xxx
Converters
EZ 1000
CON 011
CON 021
CON 031
CON 041

The sensor must be set to the center of its static measuring range or another defined position by measuring the converter output voltage.

1. Define the needed measuring range.

Figure 9-5 shows a needed unsymmetrical measuring range of $-x/4$ mm to $+x/1.33$ mm within the sensor measuring range of 0 to x mm.

Figure 9-5: Example position measuring

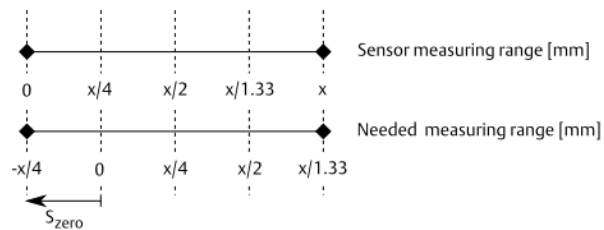

S_{zero} : Distance between the beginning of measuring range and zero position of the range or other defined shaft position.

2. Calculate the sensor adjustment voltage depending on the needed measuring range.

For adjusting the distance between measurement object (shaft collar) and sensor at zero position of the shaft or other defined position the related converter output voltage must be defined.

$$U_{zero} = \frac{(U_{SensorEnd} - U_{SensorStart}) * S_{zero}}{S_{MeasuringRange}} + U_{SensorStart}$$

Example with sensor measuring range of 0 to 2 mm, converter output voltage range of -2 V to -18 V DC and needed measuring range of -0.5 mm to +1.5 mm:

$$U_{zero} = \frac{((-2 V) - (-18 V)) * 0.5 mm}{2 mm} + (-2 V) = -6 V$$

3. Switch on the power supply of the system rack in which the Universal Measurement Card is installed.
4. Measure the output voltage of the measuring chain on the terminals OUT and \perp (GND) of the converter with a DC voltmeter.
5. Adjust the distance between sensor and measurement object so that the connected DC voltmeter displays the calculated adjustment voltage (U_{zero}).
6. Fix the sensor in that position. Ensure that the adjusted distance does not change during fixing the sensor.

See operation manual of the sensor used for further installation details.

Card configuration

Note

See [General configuration procedure](#) for description of the general configuration process.

The measured position value can be supervised on limit violation and output through:

- Current outputs.
- Modbus communication of the A6500-CC COM Card.
- OPC UA communication of the A6500-CC COM Card.

Digital alarm outputs can be used for indication of limit violation.

Select the appropriate application from the "New Configuration window".

1. Click **Two separate channels** to open the two channel application list.
2. Select **Distance static** for the appropriate channel.
3. Enter the parameters.

See [Table 9-11](#) for an example configuration of a single channel shaft position measurement with an eddy current measuring chain consisting of a PR 6423/xxx-xxx and a CON 011 with converter output voltage range -2 V to -18 V. Only significant parameters are listed.

Table 9-11: Shaft position – example configuration

Configuration page	Parameter	Value
Input 1	Sensor	PR 6423
	Converter	CON 011 -2/-18V
Linearization 1	Line 1 [V] / [mm]	-18 / 1
	Line 2 [V] / [mm]	-2 / -1
Measurement 1	Evaluation	Distance
	Tacho	Key 1
	Nominal speed [RPM]	3000
Current output 1	Current output	4 - 20 mA
	Current suppression ¹	Box checked

Table 9-11: Shaft position – example configuration (continued)

Configuration page	Parameter	Value
Alarm limits 1	Enabled	Box checked
	Upper danger alarm [mm]	0.6
	Upper alert alarm [mm]	0.4
	Lower alert alarm [mm]	-0.4
	Lower danger alarm [mm]	-0.6
	Alarm hysteresis [mm]	0.1
	Suppression	Box checked

¹ Optional parameter

- Send the configuration to the card. Click **Send & close**.

9.1.5 Single-channel – shaft position with reduced measuring range

This application example describes the configuration of the A6500-UM Universal Measurement Card in single channel - shaft position mode for position measurement with reduced measuring range. A PR 6424 eddy current sensor with a measuring range of ± 2 mm, and a converter type CON 011 with a converter output voltage of -2 to -18 V are used. The measuring range is limited to ± 1.5 mm. The ratio between sensor displacement and sensor voltage is specified through the linearization. Unit "mm" or "mil" ("mm" is used for the following example).

Figure 9-6 shows a diagram of the limited measuring range and the corresponding converter output voltage.

Figure 9-6: Position measurement with reduced range

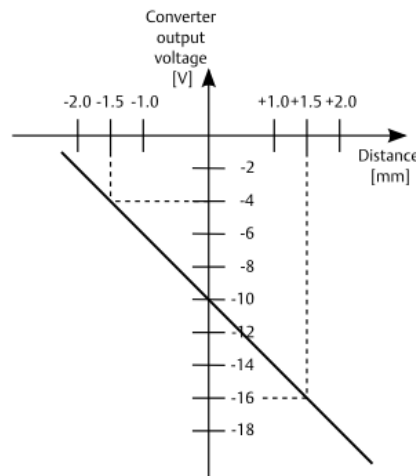

Sensor adjustment

Note

The position of the shaft must be known when adjusting the sensor.

Emerson recommends eddy current measuring chains consisting of the listed sensors and converters (see [Table 9-12](#)).

Table 9-12: Recommended sensors and converters

Sensors and converters
Sensors
EZ 105x-xx-xx-xxx
EZ 108x-xx-xx-xxx
PR 6422/xxx-xxx
PR 6423/xxx-xxx
PR 6424/xxx-xxx
PR 6425/xxx-xxx
PR 6426/xxx-xxx
Converters
EZ 1000
CON 011
CON 021
CON 031
CON 041

The sensor must be set to the center of its static measuring range or another defined position by measuring the converter output voltage.

See chapter [Sensor adjustment](#) for range definition and sensor adjustment.

Card configuration

Note

See [General configuration procedure](#) for description of the general configuration process.

The measured position value can be supervised on limit violation and output through:

- Current outputs.
- Modbus communication of the A6500-CC Com Card.
- OPC UA communication of the A6500-CC Com Card.

Digital alarm outputs can be used for indication of limit violation.

Select the appropriate application from the "New Configuration window".

1. Click **Two separate channels** to open the two channel application list.

2. Select **Distance static** for the appropriate channel.
3. Enter the parameters.
See [Table 9-13](#) for an example configuration of a single channel shaft position measurement with an eddy current measuring chain consisting of a PR 6424/xxx-xxx and a CON 011 with converter output voltage range -2 V to -18 V. Only significant parameters are listed. This example does not show an alarm limit configuration.

Table 9-13: Shaft position with reduced measuring range – example configuration

Configuration page	Parameter	Value
Input 1	Sensor	PR 6424
	Converter	CON 011 -2/-18V
Linearization 1	Line 1 [V] / [mm]	-16 / 1.5
	Line 2 [V] / [mm]	-10 / 0
	Line 3 [V] / [mm]	-4 / -1.5
Measurement 1	Evaluation	Distance
	Tacho	Key 1
	Nominal speed [RPM]	3000
Current output 1	Current output	4 - 20 mA
	Current suppression ¹	Box checked

¹ Optional parameter

Linearization

Ensure that there is an online connection between AMS Machine Studio and the measurement card.

- a. Add the required number of lines (interpolation point) to the table by clicking on the + button. The new line is added under the line. The maximum number of lines is 32. Delete a line by clicking the X button.
 - b. Enter the displacement value in the right column [mm] of the table.
 - c. Adjust precisely this displacement value between sensor and measurement object.
 - d. Click the **M** button. This triggers a voltage measurement and the voltage value measured for this displacement value appears in the input field [V]. At the same time, the newly created interpolation point is displayed in the graphic to the right.
 - e. Repeat steps [3.b](#) to [3.d](#) until all interpolation points are defined.
4. Click **Send & close** to send the configuration to the card.

9.1.6 Single-channel – Rod Drop

In this mode, both channels of the A6500-UM Universal Measurement Card are operating independently of each other. One or both channels of the card can be used for measurement of the rider band (piston ring) wear in reciprocating compressors, according to API 670, by measuring the gap between an eddy current sensor and the piston rod. Emerson recommends a key signal from a A6500-UM card in key mode.

Three different processing types are available: **Rod Drop Average Mode**, **Rod Drop Triggered Mode**, and **Rod Gap**. In AMS Machine Studio, you can choose the mode with parameter **Measurement** → **Evaluation**. Both channels operate independently of each other and calculate their own measuring value. This value can be monitored on limit value exceeding and output through the current output of the corresponding channel.

Compensating of thermal influences

During start up of a reciprocating compressor, machine parts could change their size and position due to, for example, heat influences (see [Figure 9-7](#)). This normal machine behavior could cause a measuring value offset (distance change between sensor and piston rod). Compensate this offset with the parameter **Measurement** → **Shift**.

Figure 9-7: Thermal growth of piston

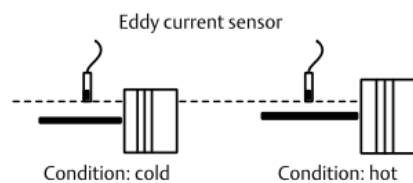

Follow the steps below to compensate the thermal influence.

Prerequisite:

- This process requires an online connection to the A6500-UM card.
- The machine should be in normal state – after start up.
 1. Open the configuration page **Measurement** of the respective channel.
 2. Click **M** to measure the current distance. The measured value will be displayed in the parameter entry field. The shift value can be also entered manually (see [Figure 9-8](#)).

Figure 9-8: Shift

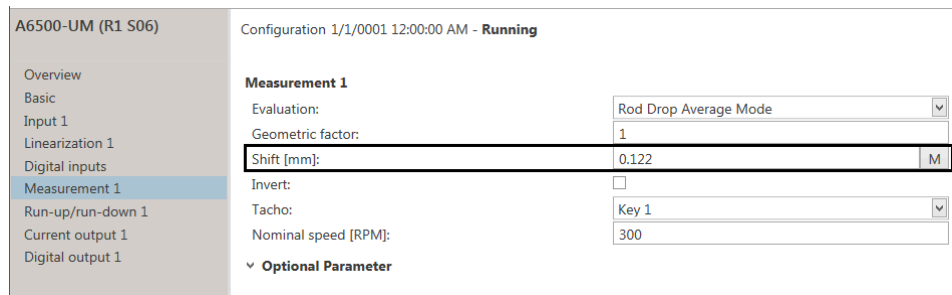

3. Click **Send & close** to send the configuration to the card.

The shift value is subtracted from the actual measured value.

Example: After start-up of the machine, the online display shows 0.122 mm. With the shift function, this value will be measured and copied to the parameter **Shift**. After sending the change to the card, the online display will show 0.00 mm.

Note

The current output of the respective channel will be adjusted accordingly.

Data acquisition

The control of the data acquisition is defined on the **Measurement** configuration page . There are two available control modes for the **Tacho** parameter:

- **Key 1 and Key 2**

The key mode requires a key signal from a A6500-UM card in key mode. The sample rate will be automatically adapted to the rotational speed. This is the recommended data acquisition mode for **Rod Drop Average Mode** and **Rod Drop Triggered Mode**. If the speed is below sub speed (**Measurement** → **Sub speed [RPM]**), the data acquisition control automatically switches to the **Time** mode. The **Time** mode uses a sample rate to support low speed processing. In all other cases, a loss of the key signal or higher speeds than overspeed (**Measurement** → **Overspeed [RPM]**), the card measures at a suitable sampling rate.

- **Time**

In **Time** mode, the measurement card works with a fixed sampling rate. The block length is adapted to support measurements from 60 to 600 RPM.

Processing type "Rod Drop Average Mode"

Rod Drop Average Mode is designed for indirect measurement of the piston gap with geometrical scaling depending on machine geometry. This measurement requires the input of a geometrical factor (**Measurement** → **Geometric factor**). Use the following formula to calculate the geometric factor:

$$\text{Geometric Factor} = 1 + \frac{D_2}{D_1}$$

Figure 9-9 shows the measurement and the definition of the variables D_1 and D_2 .

Figure 9-9: Sensor arrangement and geometric factor – Rod Drop Average Mode

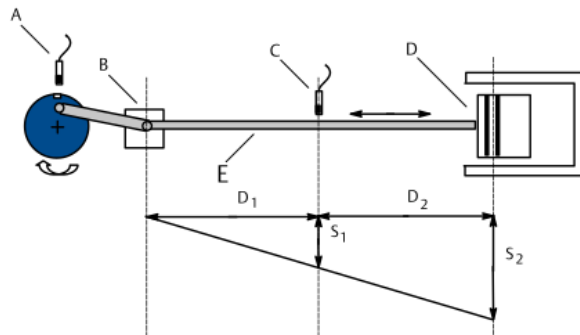

- A. Key sensor (connected to A6500-UM in key mode)
- B. Crosshead
- C. Eddy current sensor for the rod drop measurement
- D. Piston
- E. Piston rod

The measuring range depends on the geometric factor:

$$\text{Measuring Range}_{\text{adjusted}} = \text{Measuring Range} * \text{Geometric Factor}$$

Example with measuring range of ± 1 mm:

$$\text{Measuring Range}_{\text{adjusted}} = \pm 1 \text{ mm} * 2 = \pm 2 \text{ mm}$$

The current output will be adjusted accordingly.

Sensor adjustment

Emerson recommends eddy current measuring chains consisting of the sensors and converters listed in Table 9-14.

Table 9-14: Recommended sensors and converters

Sensors and converters
Sensors
EZ 105x-xx-xx-xxx
EZ 108x-xx-xx-xxx
PR 6422/xxx-xxx
PR 6423/xxx-xxx
PR 6424/xxx-xxx
PR 6425/xxx-xxx
PR 6426/xxx-xxx

Table 9-14: Recommended sensors and converters (continued)

Sensors and converters
Converters
EZ 1000
CON 011
CON 021
CON 031
CON 041

At the sensor position used to define the geometrical factor (see [Processing type "Rod Drop Average Mode"](#)), set the sensor for the rod drop measurement to the center of its static measuring range by measuring the converter output voltage.

1. Power on the System Rack in which the Universal Measurement Card is installed.
2. Measure the output voltage of the measuring chain on the terminals OUT and \perp (GND) of the converter with a DC voltmeter.
3. Adjust the distance between sensor and measurement object (piston rod) so that the measured converter output voltage is in the middle of the voltage range (for example: converter output range -2 to -18 V \rightarrow -10 V).
4. Fix the sensor in that position. Ensure that the adjusted distance does not change during fixing the sensor.

Note

If the sensor cannot be adjusted precisely to the middle of the measuring range, correct this deviation with the shift function (see chapter [Compensating of thermal influences](#)).

See operation manual of the sensor used for further installation details.

Card configuration

Note

See [General configuration procedure](#) for description of the general configuration process.

The measured values can be supervised on limit violation and output through:

- Current outputs.
- Modbus communication of the A6500-CC COM Card.
- OPC UA communication of the A6500-CC COM Card.

Digital alarm outputs can be used for indication of limit violation.

Select the appropriate application from the "New Configuration" window.

1. Click **Two separate channels** to open the two channel application list.
2. Select **Distance static** for the appropriate channel.
3. Enter the parameters.

See [Table 9-15](#) for an example configuration of a single channel Rod Drop Average Mode measurement with an eddy current measuring chain consisting of a PR 6423/

xxx-xxx and a CON 011 with converter output voltage range -2 V to -18 V. Only significant parameters are listed.

Table 9-15: Rod Drop Average Mode – parameter of example configuration

Configuration page	Parameter	Value
Input 1	Sensor	PR 6423
	Converter	CON 011 -2/-18 V
Measurement 1	Evaluation	Rod Drop Average Mode
	Geometric factor ¹	2
	Shift [mm]	0
	Tacho	Key 1
	Nominal speed [RPM]	300
Current output 1	Current output	4 - 20 mA
	Current suppression ²	Box checked
	Range min. [mm] ²	-2
	Range max. [mm] ²	2
Alarm limits 1	Enabled	Box checked
	Upper danger alarm [mm]	1.6
	Upper alert alarm [mm]	1.2
	Lower alert alarm [mm]	-1.2
	Lower danger alarm [mm]	-1.6
	Alarm hysteresis [mm]	0.1
	Latching	Box not checked
	Limit suppression	Box checked

¹ Send the configuration to the card before continuing.

² Optional Parameter

4. Click **Send & close** to send the configuration to the card.

Processing type "Rod Drop Triggered Mode"

Rod Drop Triggered Mode is designed for indirect measurement of the piston gap with geometrical scaling depending on the machine geometry and on the piston position. This measurement requires the input of a geometrical factor (**Measurement** → **Geometric factor**), of a piston angle (**Measurement** → **Piston angular degree**), and a trigger angle (**Measurement** → **Trigger angular degree** to trigger the measurement at a certain position of the piston. A key sensor is required for the detection of the trigger point. See [Single-channel – key generation](#) for information about the key generation.

Use the following formula to calculate the geometric factor:

$$\text{Geometric Factor} = 1 + \frac{D_2}{D_1}$$

Figure 9-10 explains the measurement and the definition of the variables D_1 and D_2 .

Figure 9-10: Sensor arrangement, geometric factor, and piston angle

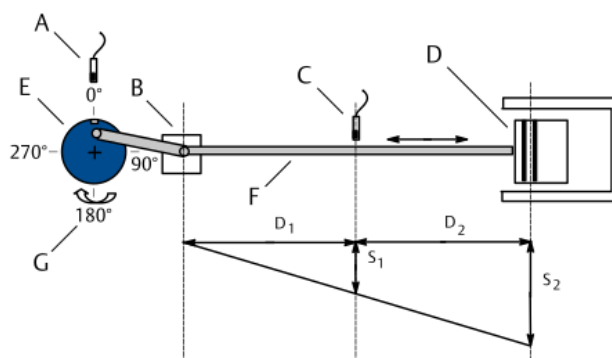

- A. Key sensor (connected to A6500-UM in key mode)
- B. Crosshead
- C. Eddy current sensor for the rod drop measurement
- D. Piston
- E. Driving shaft
- F. Piston rod
- G. Piston angle

The measuring range depends on the geometric factor:

$$\text{Measuring Range}_{\text{adjusted}} = \text{Measuring Range} * \text{Geometric Factor}$$

Example with measuring range of ± 1 mm:

$$\text{Measuring Range}_{\text{adjusted}} = \pm 1 \text{ mm} * 2 = \pm 2 \text{ mm}$$

The current output is adjusted accordingly.

The measurement of the gap between sensor and piston rod is triggered if a certain position of the driving shaft is reached defined by the entered piston angle and trigger angle. The accuracy of the trigger point depends on the speed of the driving shaft:

Table 9-16: Trigger accuracy

Speed range	Accuracy
0 to 4000 RPM	$\pm 1^\circ$
4001 to 8000 RPM	$\pm 2^\circ$
8001 to 20000 RPM	$\pm 5^\circ$
20001 to 40000 RPM	$\pm 10^\circ$

Sensor adjustment

See [Sensor adjustment](#).

Card configuration

Note

See [General configuration procedure](#) for description of the general configuration process.

The measured values can be supervised on limit violation and output through:

- Current output
- Modbus communication of the A6500-CC Com Card
- OPC UA communication of the A6500-CC Com Card

Digital alarm outputs can be used for indication of limit violation. Select the appropriate application from the **New Configuration** dialog.

1. Click **Two separate channels** to open the two channel application list.
2. Select **Distance static** for the appropriate channel.
3. Enter the parameters.

See [Table 9-17](#) for an example configuration of a single channel Rod Drop – Trigger Mode measurement with an eddy current measuring chain consisting of a PR 6423/xxx-xxx and a CON 011 with converter output voltage range -2 V to -18 V. Only significant parameters are listed.

Table 9-17: Rod Drop Triggered Mode – example configuration

Configuration page	Parameter	Value
Input 1	Sensor	PR 6423
	Converter	CON 011 -2/-18 V
Measurement 1	Evaluation	Rod Drop Triggered Mode
	Geometric factor ¹	2
	Shift [mm]	0
	Tacho	Key 1
	Nominal speed [RPM]	300
	Piston angle [°]	45
	Trigger angular degree [°] ²	90
Current output 1	Current output	4 - 20 mA
	Current suppression ³	Box checked
	Range min. [mm] ³	-2
	Range max. [mm] ³	2
Alarm limits 1	Enabled	Box checked
	Upper danger alarm [mm]	1.6
	Upper alert alarm [mm]	1.2

Table 9-17: Rod Drop Triggered Mode – example configuration (continued)

Configuration page	Parameter	Value
	Lower alert alarm [mm]	-1.2
	Lower danger alarm [mm]	-1.6
	Latching	Box not checked
	Limit suppression	Box checked

- 1 Send the configuration to the card before continuing.
- 2 Find a point on the stroke where the influence of rod mechanical runout (crosshead-to-cylinder misalignment), rod deflection, and load changes are minimized. Emerson recommends to find this point through field testing during commissioning of the application.
- 3 Optional parameter

4. Click **Send & close** to send the configuration to the card.

Processing type "Rod Gap"

Rod Gap is for direct measurement of piston gap - distance between sensor and piston rod. [Figure 9-11](#) shows the setup of the measurement.

Figure 9-11: Sensor arrangement – Rod Gap

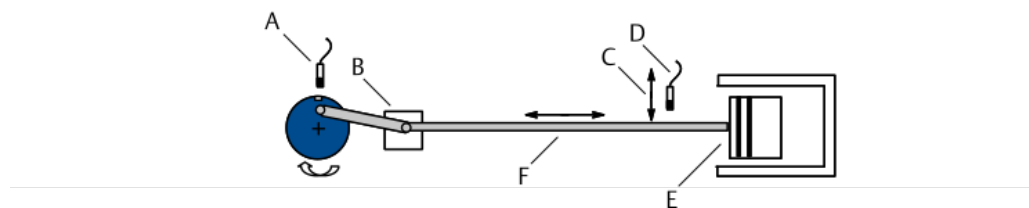

- A. Key sensor (connect to A6500-UM in key mode)
- B. Crosshead
- C. Gap
- D. Eddy current sensor for the rod gap measurement
- E. Piston
- F. Piston rod

Sensor adjustment

Emerson recommends eddy current measuring chains consisting of the listed sensors and converters (see [Table 9-18](#)).

Table 9-18: Recommended sensors and converters

Sensors and converters
Sensors
EZ 105x-xx-xx-xxx
EZ 108x-xx-xx-xxx

Table 9-18: Recommended sensors and converters (continued)

Sensors and converters
PR 6422/xxx-xxx
PR 6423/xxx-xxx
PR 6424/xxx-xxx
PR 6425/xxx-xxx
PR 6426/xxx-xxx
Converter
EZ 1000
CON 011
CON 021
CON 031
CON 041

The sensor must be set to the center of its static measuring range by measuring the converter output voltage.

1. Switch on the power supply of the system rack in which the Universal Measurement Card is installed.
2. Measure the output voltage of the measuring chain on the terminals OUT and \perp (GND) of the converter with a DC voltmeter.
3. Adjust the distance between sensor and measurement object (piston rod) so that the measured converter output voltage is in the middle of the voltage range (for example: converter output range -2 to -18 V \rightarrow -10 V).
4. Fix the sensor in that position. Ensure that the adjusted distance does not change during fixing the sensor.

Note

If the sensor cannot be adjusted precisely to the middle of the measuring range, correct this deviation with the shift function (see chapter [Compensating of thermal influences](#)).

See operation manual of the sensor used for further installation details.

Card configuration

Note

See [General configuration procedure](#) for description of the general configuration process.

The measured values can be supervised on limit violation and output through:

- Current outputs.
- Modbus communication of the A6500-CC Com Card.
- OPC UA communication of the A6500-CC Com Card.

Digital alarm outputs can be used for indication of limit violation.

Select the appropriate application from the "New Configuration" window.

1. Click **Two separate channels** to open the two channel application list.
2. Select **Distance static** for the appropriate channel.
3. Enter the parameters.

See [Table 9-19](#) for an example configuration of a single channel Rod Gap measurement with an eddy current measuring chain consisting of a PR 6423/xxx-xxx and a CON 011 with converter output voltage range -2 V to -18 V. Only significant parameters are listed.

Table 9-19: Rod Gap – example configuration

Configuration page	Parameter	Value
Input 1	Sensor	PR 6423
	Converter	CON 011 -2/-18 V
Linearization 1	Line 1 [V]/[mm]	-18 / 1
	Line 2 [V]/[mm]	-2 / -1
Measurement 1	Evaluation	Rod Gap
	Shift [mm]	0
	Tacho	Key 1
	Nominal speed [RPM]	300
Current output 2	Current output	4 - 20 mA
	Current suppression ¹	Box checked
Digital output 1	Enabled	Box checked
	Upper danger alarm [mm]	0.7
	Upper alert alarm [mm]	0.5
	Lower alert alarm [mm]	-0.5
	Lower danger alarm [mm]	-0.7
	Alarm hysteresis [mm]	0.1
	Latching	Box not checked
	Limit suppression	Box checked

¹ Optional parameter

4. Click **Send & close** to send the configuration to the card.

9.1.7 Single-channel – eccentricity S_{pp}

In eccentricity S_{pp} mode, both channels of the A6500-UM Universal Measurement Card are operating independently of each other. One or both channels of the card can be used to measure shaft eccentricity within a definable speed range. See [Table 9-20](#) for signal evaluation details (" μm " is used for the following example).

Table 9-20: Signal evaluation

Sensor type	Signal evaluation	Unit	Description
Eddy current	peak-to-peak	μm or mil	Measurement value is proportional to radial shaft displacement in peak-to-peak evaluation

The eccentricity of the shaft is the maximum amplitude of a shaft deflection (peak-to-peak value) in the sensor direction at low machine speed, during at least one shaft rotation. [Figure 9-12](#) illustrates the signal evaluation.

Figure 9-12: Diagram signals evaluation eccentricity S_{pp}

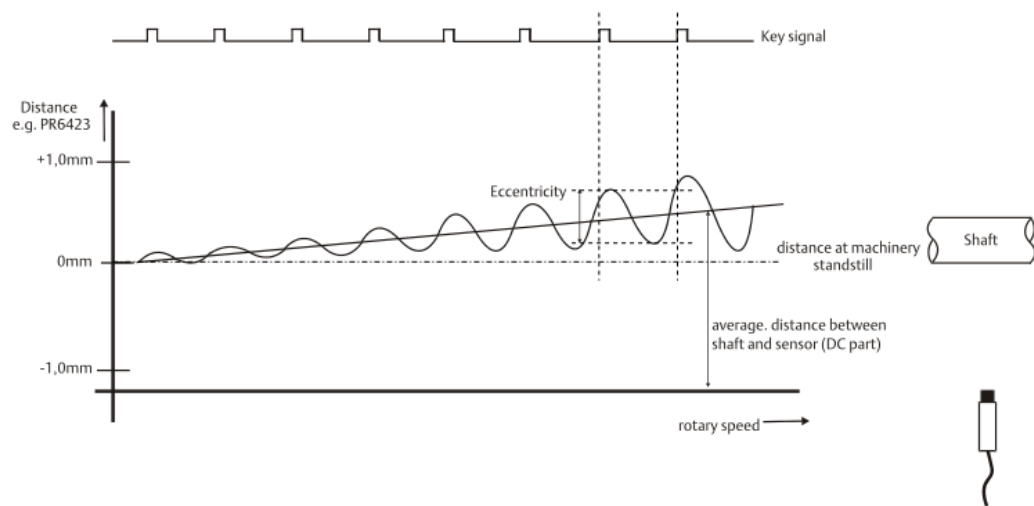

Note

The eccentricity measurement requires a key signal.

[Figure 9-13](#) shows a sensor arrangement example with an eddy current sensor mounted into the bearing to measure the eccentricity.

Figure 9-13: Sensor arrangement example – eccentricity S_{pp}

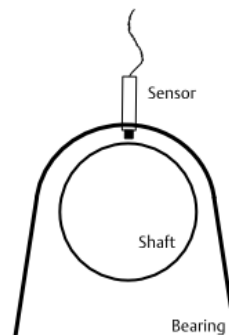

Sensor adjustment

Emerson recommends eddy current measuring chains consisting of the listed sensors and converters (see [Table 9-21](#)).

Table 9-21: Recommended sensors and converters

Sensors and converters
Sensors
EZ 105x-xx-xx-xxx
EZ 108x-xx-xx-xxx
PR 6422/xxx-xxx ¹
PR 6423/xxx-xxx ¹
PR 6424/xxx-xxx
PR 6425/xxx-xxx
Converters
EZ 1000
CON 011
CON 021
CON 031
CON 041

¹ Standard for eccentricity measurement

The sensor must be set to the center of its static measuring range by measuring the converter output voltage.

Note

When adjusting the center position, consider the lifting of the shaft caused by the oil film thickness on machines with sleeve bearings.

1. Switch on the power supply of the system rack in which the Universal Measurement Card is installed.
2. Measure the output voltage of the measuring chain on the terminals OUT and \perp (GND) on the converter with a DC voltmeter.
3. Adjust the distance between sensor and shaft so that the measured converter output voltage is in the center of the voltage range (for example, -2 to -18 V) approximately -10 V.
4. Fix the sensor in that position.

See operation manual of the sensor used for further installation details.

Card configuration

Note

See [General configuration procedure](#) for description of the general configuration process.

The measured vibration value can be supervised on limit violation and output through:

- Current outputs.
- Modbus communication of the A6500-CC Com Card.
- OPC UA communication of the A6500-CC Com Card.

Digital alarm outputs can be used for indication of limit violation.

Select the appropriate application from the "New Configuration" window.

1. Click **Two separate channels** to open the two channel application list.
2. Select **Eccentricity** for the appropriate channel.
3. Enter the parameters.

See [Table 9-22](#) for an example configuration of a single channel eccentricity measurement with an eddy current measuring chain consisting of a PR 6423/xxx-xxx and a CON 011 with converter output voltage range -2 V to -18 V. Only significant parameters are listed.

Table 9-22: Eccentricity – example configuration

Configuration page	Parameter	Value
Input 1	Sensor	PR 6423
	Converter	CON 011 -2/-18 V
Measurement 1	Evaluation	Peak-Peak
	Tacho	Key 1
	Start speed [RPM] ¹	5
	End speed [RPM] ¹	300
Current output 1	Current output	4 - 20 mA
	Current suppression ¹	Box checked
Alarm limits 1	Enabled	Box checked
	Danger alarm [µm]	110
	Alert alarm [µm]	95
	Alarm hysteresis [µm]	5
	Latching	Box not checked
	Limit suppression	Box checked

¹ Optional parameter

4. Click **Send & close** to send the configuration to the card.

9.1.8 Single-channel – eccentricity minimum/maximum

In this mode, both channels of the A6500-UM Universal Measurement Card are operating independently of each other. One or both channels of the card can be used for

measurement of the minimum or maximum shaft eccentricity within a definable speed range. See [Table 9-23](#) for signal evaluation details (" μm " is used for the following example).

Table 9-23: Signal evaluation

Sensor type	Signal evaluation	Unit	Description
Eddy current	Minimum	μm or mil	Measurement value is proportional to the lowest radial shaft displacement based on the configured beginning of the measuring range.
	Maximum	μm or mil	Measurement value is proportional to the greatest radial shaft displacement.

In this mode, the greatest and smallest distance between a freely selectable reference point (initial value measuring range) and the shaft surface is measured and output as minimum or maximum value at low machine speed, during at least one shaft rotation. [Figure 9-14](#) illustrates the signal evaluation.

Figure 9-14: Diagram signals evaluation eccentricity minimum/maximum

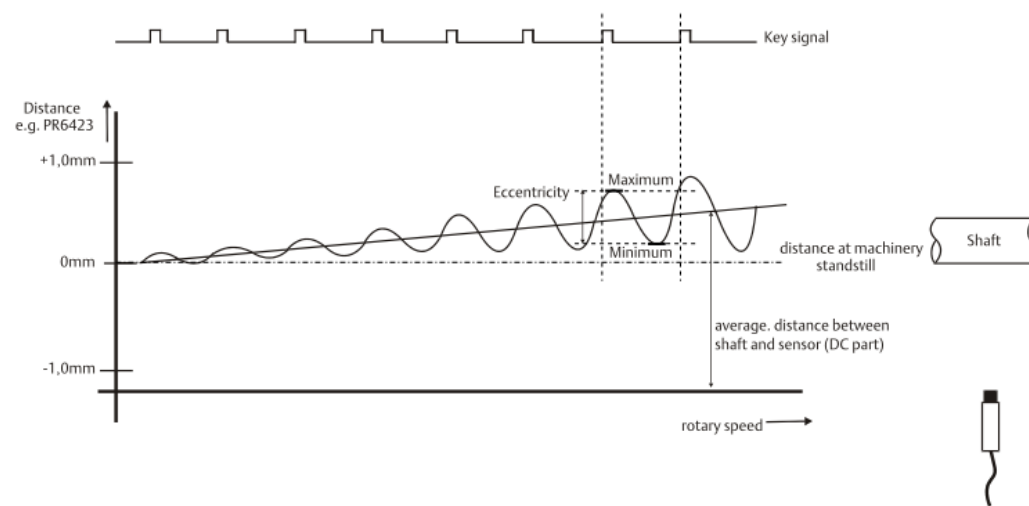

Note

The eccentricity measurement requires a key signal.

[Figure 9-15](#) shows a sensor arrangement example with an eddy current sensor mounted into the bearing to measure the eccentricity.

Figure 9-15: Sensor arrangement example – eccentricity minimum/maximum

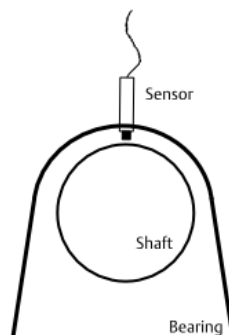

Sensor adjustment

Emerson recommends eddy current measuring chains consisting of the listed sensors and converters (see [Table 9-24](#)).

Table 9-24: Recommended sensors and converters

Sensors and converters
Sensors
EZ 105x-xx-xx-xxx ¹
EZ 108x-xx-xx-xxx ¹
PR 6422/xxx-xxx ¹
PR 6423/xxx-xxx ¹
PR 6424/xxx-xxx
PR 6425/xxx-xxx
Converters
EZ 1000
CON 011
CON 021
CON 031
CON 041

¹ Standard for eccentricity measurement

The sensor position defines the reference point for the minimum or maximum measurement. Set the sensor to the respective position within its static measuring range by measuring the converter output voltage (see [Measuring range](#) for example).

Note

When adjusting the sensor position, consider the lifting of the shaft caused by the oil film thickness. Applies to machines with sleeve bearings.

1. Switch on the power supply of the system rack in which the Universal Measurement Card is installed.
2. Measure the output voltage of the measuring chain on the terminals OUT and \perp (GND) on the converter with a DC voltmeter.
3. Adjust the distance between sensor and shaft so that the measured converter output voltage is equal to the reference point (for example, -6.0 V at -2 to -18 V output range).
4. Fix the sensor in that position.

See operation manual of the sensor used for further installation details.

Measuring range

Use the parameter **Shift** to define the reference point of the measuring range within the sensor measuring range. The measuring range beginning is defined as the smallest distance from the sensor to the measurement object.

Reference point adjustment.

1. Ensure that there is an online connection to the Universal Measurement Card.
2. Click button **M** behind the entry field of parameter **Shift**.
The card measures the current voltage and enters the respective distance value into the entry field.

Minimum

- The minimum distance between sensor and shaft during one shaft rotation is supervised.
- The effective direction is from the maximum distance to the minimum distance.
- The alert alarm limit must be higher than the danger alarm limit.

The upper diagram on [Figure 9-16](#) shows a -6.0 V reference point at a measuring range of 0 μm to 500 μm for channel evaluation **Minimum**.

Maximum

- The maximum distance between sensor and shaft during one shaft rotation is supervised.
- The effective direction is from the minimum distance to the maximum distance.
- The alert alarm limit must be lower than the danger alarm limit.

The lower diagram on [Figure 9-16](#) shows a -6.0 V reference point at a measuring range of 0 μm to 500 μm for channel evaluation **Maximum**.

Figure 9-16: Diagram measuring range evaluation minimum and maximum

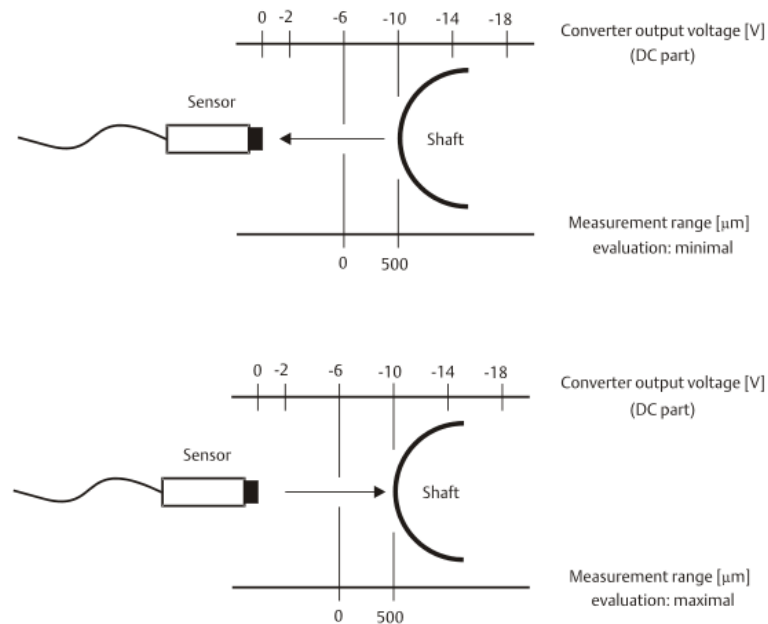

Card configuration

Note

See [General configuration procedure](#) for description of the general configuration process.

The measured minimum or maximum eccentricity value can be supervised on limit violation and output through:

- Current outputs.
- Modbus communication of the A6500-CC Com Card.
- OPC UA communication of the A6500-CC Com Card.

Digital alarm outputs can be used for indication of limit violation.

Select the appropriate application from the "New Configuration" window.

1. Click **Two separate channels** to open the two channel application list.
2. Select **Eccentricity** for the appropriate channel.
3. Enter the parameters.

See [Table 9-25](#) for an example configuration of a single channel eccentricity minimum measurement with an eddy current measuring chain consisting of a PR 6423/xxx-xxx and a CON 011 with converter output voltage range -2 V to -18 V. Reference point at -6.0 V (500 µm) Only significant parameters are listed.

Table 9-25: Eccentricity minimum/maximum – example configuration

Configuration page	Parameter	Value
Input 1	Sensor	PR 6423

Table 9-25: Eccentricity minimum/maximum – example configuration
(continued)

Configuration page	Parameter	Value
	Converter	CON 011 -2/-18 V
Measurement 1	Evaluation	Minimum
	Begin [μm]	0
	End [μm]	500
	Shift [μm]	-500
	Tacho	Key 1
	Start speed [RPM] ¹	5
	End speed [RPM] ¹	300
Current output 1	Mode	4 - 20 mA
	Current suppression ¹	Box checked
Alarm limits 1	Enabled	Box checked
	Danger alarm [μm]	100
	Alert alarm [μm]	150
	Alarm hysteresis [μm]	5
	Latching	Box not checked
	Limit suppression	Box checked

¹ Optional parameter

- Click **Send & close** to send the configuration to the card.

9.1.9 Single-channel – housing expansion

In this mode, both channels of the A6500-UM Universal Measurement Card are operating independently of each other. One or both channels of the card can be used for distance measurements as, for example, absolute housing expansion, valve position, and so on in the unit "mm" or "mil" ("mm" is used for the following example).

Note

Connection of PR 9350/xx linear displacement transducers or similar sensors to the A6500-UM always requires the A6500-LC converter.

Figure 9-17 shows an example with an PR 9350/02 linear displacement transducer measuring the housing expansion in a symmetrical measuring range of +/- 20 mm and an unsymmetrical range of -10 to +30 mm.

Figure 9-17: Sensor arrangement example – single-channel housing expansion

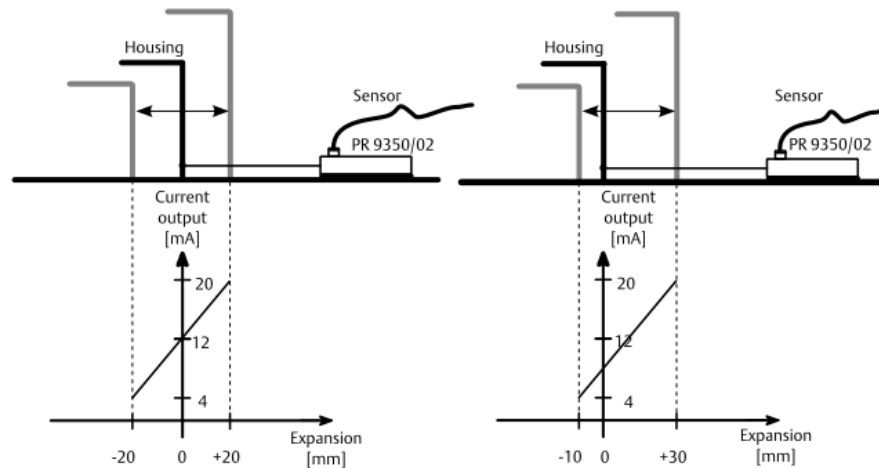

Sensor adjustment

Note

The position of the measuring object, for example, of the housing must be known when adjusting the sensor.

Connection of a PR 9350/xx linear displacement transducer to the A6500-UM always requires the A6500-LC converter.

Follow the commissioning instructions in the A6500-LC operating manual (MHM-97878).

See operation manual of the sensor used for further installation details.

Card configuration

Note

See [General configuration procedure](#) for description of the general configuration process.

The measured expansion value can be supervised on limit violation and output through:

- Current outputs.
- Modbus communication of the A6500-CC COM Card.
- OPC UA communication of the A6500-CC COM Card.

Digital alarm outputs can be used for indication of limit violation.

Select the appropriate application from the "New Configuration" window.

1. Click **Two separate channels** to open the two channel application list.
2. Select **Distance static** for the appropriate channel.
3. Enter the parameters.

See [Table 9-26](#) for an example configuration of a single channel housing expansion measurement with a PR 9350/02 linear displacement transducer. Only significant parameters are listed.

Table 9-26: Housing expansion – example configuration

Configuration page	Parameter	Value
Input 1	Sensor	PR 9350/02
	Converter	A6500-LC 4V/(100mV/V)
Linearization 1	Line 1 [V] / [mm]	5.4 / -25
	Line 2 [V] / [mm]	14.6 / +25
Measurement 1	Evaluation	Distance
	Tacho	Key 1
	Nominal speed [RPM]	3000
Current output 1	Current output	4 - 20 mA
	Current Suppression ¹	Box checked
Alarm limits 1	Enabled	Box checked
	Upper danger alarm [mm]	20
	Upper alert alarm [mm]	15
	Lower alert alarm [mm]	-15
	Lower danger alarm [mm]	-20
	Alarm hysteresis [mm]	1
	Suppression	Box checked

¹ Optional parameter

- Click **Send & close** to send the configuration to the card.

9.1.10 Single-channel – speed measurement

In this mode, both channels of the A6500-UM Universal Measurement Card are operating independently of each other. One or both channels of the card can be used for measurement of the shaft speed in unit "rpm".

Mechanical requirements for speed measurement

A reliable speed measurement requires a trigger wheel with a definite mechanical design which depends on the sensor used.

Using eddy current measuring chains for speed measurement

Boundary conditions for the following trigger wheel recommendations:

- Eddy current measuring chains with sensors PR 6422, PR 6423, and PR 6424
- Measuring chains are calibrated on the respective material of the trigger wheel (standard calibration material is 42 Cr Mo 4)
- No Ex-application (influence of safety barriers is described in the operating manual of the signal converter)

Trigger wheel with rectangular tooth profile (recommended)

Emerson recommends trigger wheels with rectangular tooth profile as this types generates, together with eddy current sensors, the highest output amplitude. High output amplitudes ensure proper speeds detection. [Figure 9-18](#) shows such tooth profile.

Figure 9-18: Rectangular tooth profile

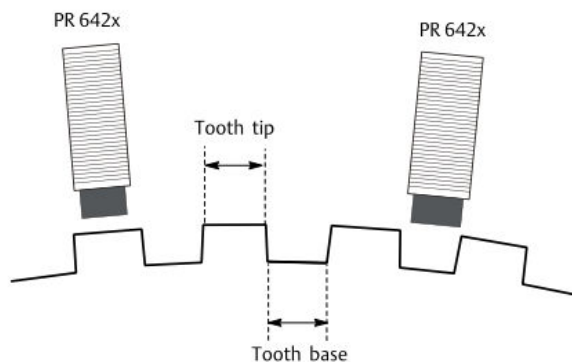

Further mechanical requirements:

Tooth depth

Choose the tooth depth greater than the measuring range of the eddy current sensor used so that the sensor can not detect the tooth base. This results in a higher signal amplitude and a better signal-noise ratio.

A standard value for the tooth depth is approximately twice the sensor measuring range. For example, the tooth depth should be approximately 4 mm if sensor PR 6423 with 2 mm measuring range is used (see [Figure 9-19](#)).

Figure 9-19: Tooth depth



Trigger wheel width

Use a trigger wheel with a width larger than $D+2 \cdot X$ plus the expected axial displacement (see [Figure 9-20](#)).

⚠ CAUTION

An insufficient width of the trigger wheel may lead to reduction of signal amplitude or loss of speed signal.

[Table 9-27](#) shows the distance X depending on the sensor type.

Table 9-27: Distance X depending on sensor type

Sensor type	Sensor head diameter D [mm]	Distance X [mm]
PR 6422	5.2	5

Table 9-27: Distance X depending on sensor type (continued)

Sensor type	Sensor head diameter D [mm]	Distance X [mm]
PR 6423	8	3
PR 6424	16	3

Example for the minimum width if using a PR 6423 and 2 mm axial displacement:

$$\text{Width}_{\min} = D + 2 * X + \text{Axial displacement}$$

$$\text{Width}_{\min} = 8 \text{ mm} + 2 * 3 \text{ mm} + 2 \text{ mm} = 16 \text{ mm}$$

Figure 9-20: Trigger wheel width

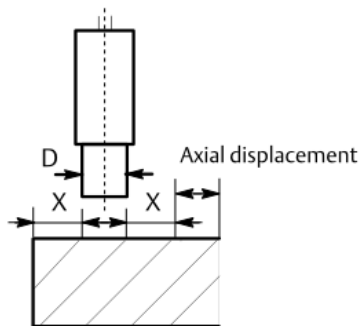

Module

Select a suitable eddy current sensor with the trigger wheel module (gear parameter). Use the following formula to calculate the module (gear parameter).

$$\text{Module} = \frac{P}{\pi}$$

Pitch P is the distance between the tooth centers on the pitch circle (see [Figure 9-21](#)). Recommended modules for individual sensor types:

- PR 6422: module ≥ 4
- PR 6423: module ≥ 6
- PR 6424: module ≥ 10

Figure 9-21: Pitch P at rectangular tooth

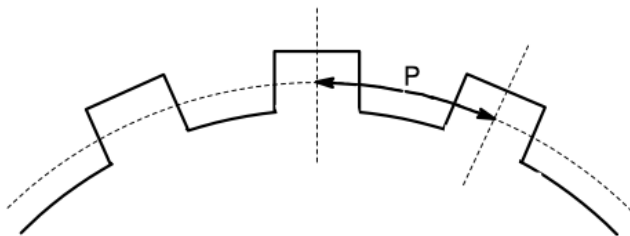

Trigger wheel with chamfered flanks (gear wheel)

Mechanical requirements for using eddy current measuring chains with sensors PR 6422, PR 6423, or PR 6424:

- The width of the wheel should meet the requirements as described in chapter [Trigger wheel with rectangular tooth profile \(recommended\)](#) - Trigger wheel width.
- Recommended width of the toothtip:
 - PR 6422: 4 mm
 - PR 6423: 6 mm
 - PR 6424: 12 mm
- Module if using trigger wheels with normal tothing:
 - PR 6422: module ≥ 8
 - PR 6423: module ≥ 12
 - PR 6424: module ≥ 24

Use the following formula to calculate the module (gear parameter).

$$\text{Module} = \frac{P}{\pi}$$

Pitch P is the distance between the tooth centers on the pitch circle (see [Figure 9-22](#)).

Figure 9-22: Pitch P and width of tooth tip

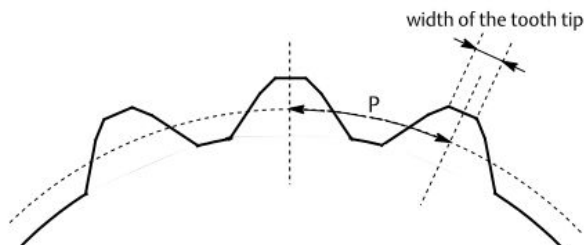

PR 9376 Hall effect sensor

Trigger wheel material must be a magnetically soft iron or steel (for example: ST 37).

[Figure 9-23](#) shows the minimum required dimensions of a trigger wheel.

Figure 9-23: PR 9376 - trigger wheel dimensions

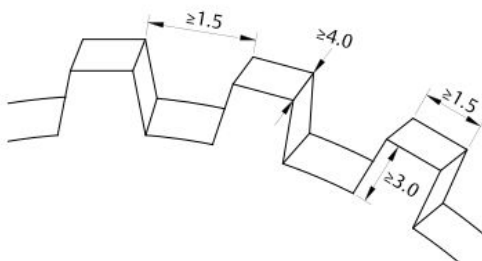

All dimensions in mm.

For further information see sensor manual.

VR sensor (variable reluctance sensor)

For trigger wheel requirements, see associated sensor documentation.

Speed sensor adjustment

To achieve a sufficient signal amplitude, mount the sensor as close as possible to the trigger wheel by observing the following minimum distance:

$$\text{Distance} = \text{Initial gap}_{\text{Sensor}} + \text{Radial clearance}_{\text{Trigger wheel}}$$

For initial gap of the sensor, see calibration protocol of the sensor used. A typical gap value for the PR 6422 is approximately 0.25 mm and for the PR 6423 approximately 0.55 mm.

Note

When adjusting the distance, consider the lifting of the trigger wheel caused by the oil film thickness. Applies to machines with sleeve bearings.

Figure 9-24: Distance between sensor and tooth

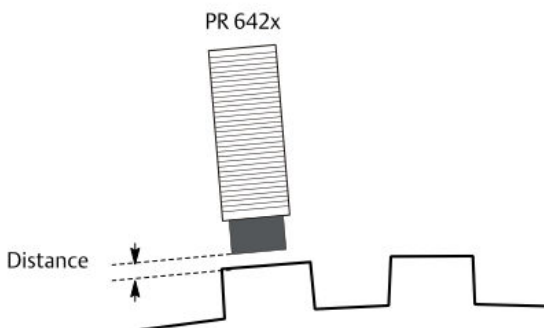

Radial clearance (radial vibration amplitude)

Consider the radial vibration amplitude of the trigger wheel. The influence of the radial vibration should be kept as small as possible. A guiding value for the maximum radial vibration is about 1/10 of the sensor measuring range.

Example: At a sensor measuring range of 2 mm, the maximum permissible radial vibration amplitude is 200 μm. A sensitivity of 8 V/mm of the eddy current measuring chain results in a disturbance voltage amplitude of 1.6 V.

Sensor adjustment voltage

Use the formula for calculating the sensor adjustment voltage.

$$U_{\text{Adjust min}} = U_{\text{Start}} + \frac{\text{Distance} * (U_{\text{End}} - U_{\text{Start}})}{\text{MR}_{\text{Sensor}}}$$

$U_{\text{Adjust min}}$: minimum required adjustment level

U_{Start} : start value of the voltage range of the eddy current measuring chain

U_{End} : end value of the voltage range of the eddy current measuring chain

$\text{MR}_{\text{Sensor}}$: Measuring range of the eddy current measuring chain

Distance: Radial clearance plus any other possibly available radial trigger wheel displacements as for example wheel lifting at sleeve bearings

Example with eddy current measuring chain (measuring range 2 mm, output voltage range -2 to -18 V), radial clearance 0.2 mm, and trigger wheel lifting 0.2 mm:

$$U_{\text{Adjust min}} = -2 \text{ V} + \frac{0.4 \text{ mm} * (-18 \text{ V} - (-2 \text{ V}))}{2 \text{ mm}} = -5.2 \text{ V}$$

At an initial gap of 0.55 mm of a PR 6423 corresponds -5.2 V to a distance of 0.95 mm between sensor and trigger wheel. At a maximum output voltage (including non linear range) of -21 V results in a maximum signal amplitude of approximately 16 V (see [Figure 9-25](#)).

Figure 9-25: Sensor adjustment example

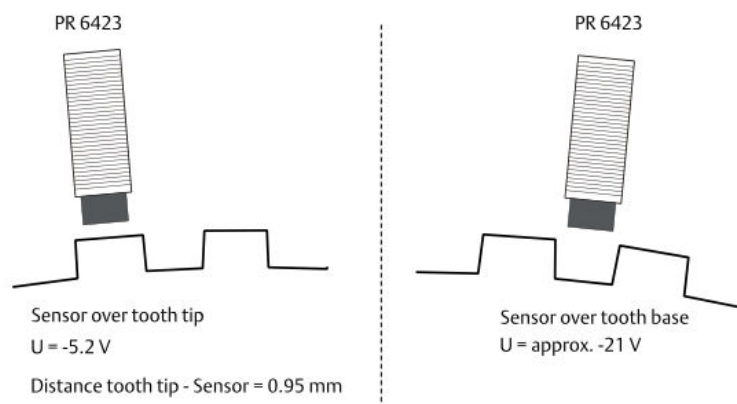

Adjustment

1. Switch on the power supply of the System Rack in which the Universal Measurement Card is installed.

2. Measure the output voltage of the measuring chain on the terminals OUT and \perp (GND) on the converter with a DC voltmeter.
3. Ensure that the sensor is completely facing a tooth of the trigger wheel.
4. Adjust the distance between sensor and tooth tip so that the connected DC voltmeter displays the calculated adjustment voltage ($U_{\text{Adjust min}}$).
5. Fix the sensor in that position. Ensure that the adjusted distance does not change during fixing the sensor.

Note

After the sensor adjustment, check the signal at the sensor signal sockets of the A6500-UM Card (see [Sensor raw signal outputs](#)) with an oscilloscope to ensure a sufficient signal amplitude. The trigger wheel must turn for this check.

- Minimum signal amplitude if **Input mode** → **Static (slow)** has been chosen: never lower than 2.0 V.
- Minimum signal amplitude if **Input mode** → **Dynamic (fast)** has been chosen: never lower than 6.0 V.

Note

If it is not possible to electrically adjust the sensor in front of a tooth then adjust the sensor mechanically by using a mechanical distance gauge.

⚠ CAUTION

Take great care if adjusting the sensor with the distance gauge still in position. The sensor may be damaged while tightening the sensor screw.

PR 9376 Hall-effect sensor

For adjustment of Hall-effect sensors see sensor manual.

Note

Adjust the sensor to its operating distance with a thickness-gauge and in a voltage-free condition. Mounting the sensor with connected supply voltage can lead to misadjustment of the trigger thresholds. If the sensor seems to be misadjusted, disconnect it from the supply voltage briefly. After power-on, the sensor will “learn” the new trigger levels.

Note

After the sensor adjustment, check the signal at the sensor signal sockets of the A6500-UM Card (see [Sensor raw signal outputs](#)) with an oscilloscope to ensure a sufficient signal amplitude. The trigger wheel must turn for this check.

- Minimum signal amplitude if **Input mode** → **Static (slow)** has been chosen: never lower than 2.0 V.
- Minimum signal amplitude if **Input mode** → **Dynamic (fast)** has been chosen: never lower than 6.0 V.

VR sensor (variable reluctance sensor)

For adjustment of VR sensors see associated sensor documentation.

Note

After the sensor adjustment, check the signal at the sensor signal sockets of the A6500-UM Card (see [Sensor raw signal outputs](#)) with an oscilloscope to ensure a sufficient signal amplitude. The trigger wheel must turn for this check.

- Minimum signal amplitude if **Input mode** → **Static (slow)** has been chosen: never lower than 2.0 V.
 - Minimum signal amplitude if **Input mode** → **Dynamic (fast)** has been chosen: never lower than 6.0 V.
-

Trigger level definition

Note

The application uses fixed trigger levels in the dynamic speed mode.

See [Trigger threshold limit detection](#).

Card configuration

Note

See [General configuration procedure](#) for description of the general configuration process.

The measured position value can be supervised on limit violation and output through:

- Current outputs.
- Modbus communication of the A6500-CC Com Card.
- OPC UA communication of the A6500-CC Com Card.

Digital alarm outputs can be used for indication of limit violation.

Select the appropriate application from the "New Configuration" window.

1. Click **Calculation based on two channels** to open the application list.
2. Select **Speed**.
3. Enter the parameters.

See [Table 9-28](#) for an example configuration of a single channel speed measurement with an eddy current measuring chain consisting of a PR 6423/xxx-xxx and a CON 011 with converter output voltage range -2 V to -18 V. Only significant parameters are listed.

Table 9-28: Speed – example configuration

Configuration page	Parameter	Value
Input 1	Sensor	PR 6423
	Converter	CON 011 -2/-18V
Measurement 1	Channel off	Box not checked
	Measure mode	n times per rotation
	Glitch suppression	Box checked
	Maximum speed [RPM]	3500

Table 9-28: Speed – example configuration (continued)

Configuration page	Parameter	Value
	Symmetry [%]	50
	Input mode	Dynamic (fast)
	Number of teeth	32
	Gap threshold limit [V] ¹	-2 V
Current output 1	Evaluation	Speed
	Current output	4 - 20 mA
	Current suppression ¹	Box checked
Digital outputs	Out 1 (Ch 1 - Speed / >= Limit)	3000
	Out 2 (Ch 1 - Speed / >= Limit)	2800
	Out 4 (Ch 1 - Standstill / Normal)	---
	Out 5 (Ch 1 - GapWarning / Normal)	---
	Limit suppression	Box checked

¹ Optional parameter

- Click **Send & close** to send the configuration to the card.

9.1.11 Single-channel – key generation

In this mode, both channels of the A6500-UM Universal Measurement Card are operating independently of each other. One or both channels of the card can be used for generation of a key signal once per rotation.

See A6500-xR System Racks operation manual for providing the key signal to other devices.

Mechanical requirements for the key signal generation

For the key signal generation with one pulse per rotation, one mark on the shaft or on a wheel is required. The mark may be a groove or a tooth. The size of the mark depends on the sensor used.

Eddy current measuring chains

Groove requirements:

- The width of the trigger mark in radial direction (w_M) must be at least twice the diameter of the sensor head and not less than 1% of the shaft circumference.
- The length of the trigger mark in axial direction (l_M) must be at least twice the head diameter of the sensor plus the maximum axial shaft displacement at the position of the trigger mark.
- The depth of a trigger mark must be at least 1 mm (see [Figure 9-26](#)).

Figure 9-26: Groove as trigger mark

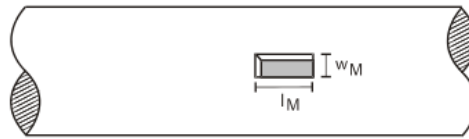

Tooth requirements:

See [Using eddy current measuring chains for speed measurement](#) for tooth requirements.

Glued trigger mark

If no trigger mark is available, place a piece of copper foil on the shaft as a trigger mark. Use an eddy current sensor for measuring at such a mark (preferably PR 6423).

Requirements:

- The environmental temperature does not exceed 60°C
- Thickness of the copper foil approximately 30 μm .
- The width of the foil in radial direction should be 2 x sensor head diameter.
- The length of the foil in axial direction has to be 2 x sensor head diameter plus the maximum axial shaft displacement at this position.
- The corners should be rounded off.

With this arrangement, pulses with an amplitude of about 10 V can be generated.

1. Ensure that the gluing spot is smoothed, cleaned, and degreased thoroughly with an acetone-based cleaner.
2. Mark the position of the foil on the shaft.
3. Spread an adhesive (for example, Loctite 480 - follow the instructions of the used adhesive) underneath the foil.
4. Place the foil on the prepared shaft surface.
5. Cover the foil with a piece of Teflon and place a piece of rubber or similar of sufficient size on it.
6. Then place it under a tension belt to press it down and allow the adhesive to dry.
7. After the drying process remove tension belt, rubber, and Teflon piece.

PR 9376 Hall-effect sensors

Groove requirements:

- The width of the trigger mark in radial direction must be at least 12 mm.
- The length of the trigger mark in axial direction must be at least 12 mm plus the maximum axial shaft displacement at the position of the trigger mark.
- The depth of a trigger mark must be at least 3 mm (see [Figure 9-27](#)).

Figure 9-27: Dimensions groove and sensor adjustment

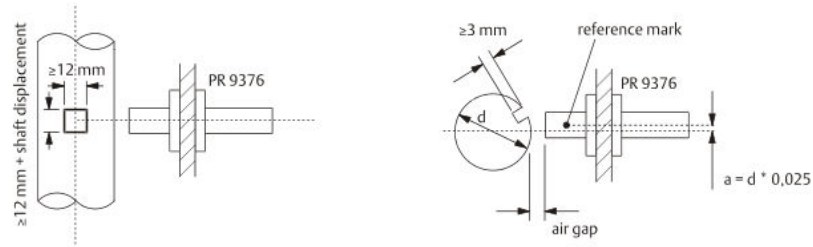

Tooth requirements:

- The width of the tooth in radial direction must be at least 1.5 mm.
- The length of the tooth in axial direction must be at least 4 mm plus the maximum axial shaft displacement at the position of the trigger mark.
- The height of the tooth must be at least 3 mm (see [Figure 9-28](#)).

Figure 9-28: Dimensions tooth and sensor adjustment

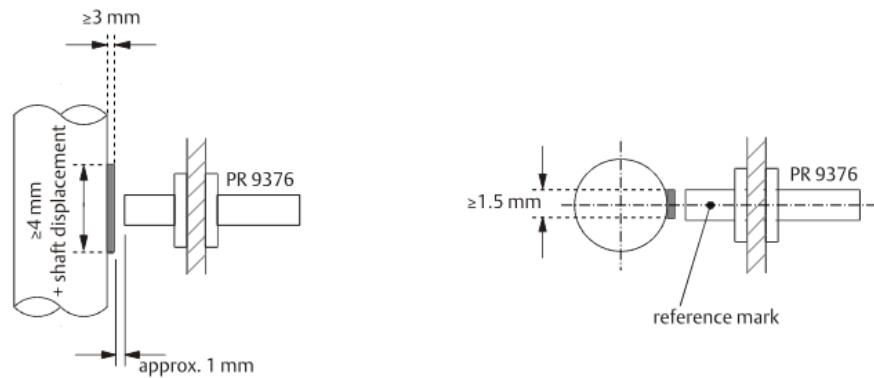

VR sensor (variable reluctance sensor)

For trigger wheel requirements, see associated sensor documentation.

Sensor adjustment

Independent of the sensor type used, adjust the distance between sensor head and trigger target (trigger wheel or shaft with groove) at the highest point of the trigger target. The highest point must be precisely centrally in front of the sensor head.

Eddy current measuring chains

See [Speed sensor adjustment](#) for sensor adjustment.

PR 9376 Hall-effect sensors

1. Ensure that the sensor supply is switched off.
2. Adjust the PR 9376 sensor to a distance (air gap) of approximately 1 mm between sensor head and highest point of the trigger mark.

3. Ensure that the reference mark of the sensor shows in axial direction of the shaft, see [Figure 9-27](#) and [Figure 9-28](#)
4. Fix the sensor in that position.
5. Switch on the sensor supply voltage.

Note

Adjust the sensor to its operating distance by means of a thickness-gauge and in a voltage-free condition! Calibration of the sensor with connected supply voltage can lead to misadjustment of the trigger thresholds. If the sensor seems to be misadjusted, it has to be disconnected from the supply voltage for a short moment. After power-on the sensor will “learn” the new trigger levels.

VR sensor (variable reluctance sensor)

For adjustment of VR sensors, see associated sensor documentation.

Trigger level definition

See [Trigger level definition](#) for the trigger level definition.

Card configuration

Note

See [General configuration procedure](#) for description of the general configuration process.

Select the appropriate application from the "New Configuration window".

1. Click **Calculation based on two channels** to open the application list.
2. Select **Speed**.
3. Enter the parameters.

See [Table 9-29](#) for an example configuration of a single channel key generation with an eddy current measuring chain consisting of a PR 6423/xxx-xxx and a CON 011 with converter output voltage range -2 V to -18 V. Only significant parameters are listed.

Table 9-29: Key – example configuration

Configuration page	Parameter	Value
Input 1	Sensor	PR 6423
	Converter	CON 011 -2/-18V
Measurement 1	Channel off	Box not checked
	Measure mode	once per rotation
	Glitch suppression	Box checked
	Maximum speed [RPM]	3500
	Symmetry [%]	1
	Input mode	Dynamic (fast)
	Number of teeth	1

Table 9-29: Key – example configuration (continued)

Configuration page	Parameter	Value
	Gap threshold limit [V] ¹	-2 V
	Pulse out ¹	Box checked
	Pulse out function ¹	once per rotation
	Pulse out inversion ¹	normal

¹ Optional parameter

4. Click **Send & close** to send the configuration to the card

9.1.12 Single-channel – dynamic pressure

In this mode, both channels of the A6500-UM Universal Measuring Card are operating independently of each other. One or both channels of the card can be used to measure dynamic pressure, such as occurring at gas turbines. See [Table 9-30](#) for signal evaluation details.

Table 9-30: Signal evaluation

Sensor type	Signal evaluation	Unit	Description
Piezoelectric pressure sensors like Meggitt CP103 / IPC 704 / GSI 127 or IMI 121A45.	0-to-peak	mbar or psi	The measurement value is proportional to the dynamic pressure measured by a piezoelectric pressure sensor in 0-to-peak evaluation.
	peak-to-peak		The measurement value is proportional to the dynamic pressure measured by a piezoelectric pressure sensor in peak-to-peak evaluation.
	RMS ¹		The measurement value is proportional to the dynamic pressure measured by a piezoelectric pressure sensor in RMS ¹ evaluation.

¹ Root Mean Square

Figure 9-29: Sensor arrangement example – single-channel dynamic pressure

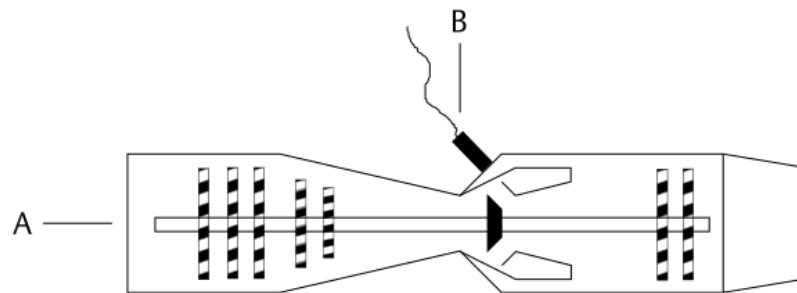

- A. Gas turbine
- B. Dynamic pressure sensor

Sensor adjustment

See respective sensor manuals for adjustment instructions.

Card configuration

Note

See [General configuration procedure](#) for a description of the general configuration process.

The measured pressure value can be supervised on limit violation and output through:

- Current outputs
- Modbus communication
- OPC UA communication

Digital alarm outputs can be used for indication of limit violation.

Procedure

1. Select the application in the **New Configuration** dialog.
 - a) Click **Two separate channels** to open the two channel application list.
 - b) Select **Dynamic pressure** for the appropriate channel.
 - c) Click **Create Configuration**.

2. Enter parameters.

See [Table 9-31](#) for an example configuration of a single channel dynamic pressure measurement with a measuring chain consisting of sensor Meggitt CP 103, charge amplifier IPC 704, and galvanic separator GSI 127. Only the significant parameters for the measurements are listed.

Table 9-31: Dynamic pressure – example configuration

Configuration page	Parameter	Value
Input 1	Sensor	CP 103 / IPC 704 / GSI 127

Table 9-31: Dynamic pressure – example configuration (continued)

Configuration page	Parameter	Value
Measurement 1	Evaluation	Dynamic Pressure RMS
	Measuring range [mbar]	150
	Tacho	Key 1
	Nominal speed [rpm]	3000
Current output 1	Current output	4 -20 mA
	Current suppression ¹	Box checked
Alarm limits 1	Danger alarm [mbar]	100
	Alert alarm [mbar]	80
	Alarm hysteresis [mbar]	5
	Latching	Box not checked
	Limit suppression	Box checked

¹ Optional parameter

3. Click **Send & close** to send the configuration to the card.

9.1.13 Single-channel – cylinder pressure

In this mode, both channels of the A6500-UM Universal Measurement Card are operating independently of each other. One or both channels of the card can be used to measure pressure and forces at reciprocating compressors. See [Table 9-32](#) for signal evaluation details. Each evaluation requires a key-signal.

Table 9-32: Signal evaluation

Sensor type	Signal evaluation	Unit	Description
Static pressure sensor	Discharge pressure	kPa or psi(g)	Pressure inside the Cylinder at top dead center position.
	Suction pressure		Pressure inside the cylinder at bottom dead center position.
	Maximum/minimum pressure		Minimum/maximum pressure inside the cylinder over one cycle.
	Compression ratio		Ratio between Discharge pressure and Suction pressure .
	Peak rod compression	kN	Peak combined rod load in compressing direction.
	Peak rod tension		Peak combined rod load in tension direction.

Table 9-32: Signal evaluation (continued)

Sensor type	Signal evaluation	Unit	Description
	Degree of rod reversal	°	Smallest distance between the points of zero force (combined road load) represents the degrees of rod reversal.

The static pressure sensor is typically installed into a pressure indicator port of the reciprocating compressor to be supervised.

Sensor adjustment

See respective sensor manual for adjustment instructions.

Card configuration

Note

See [General configuration procedure](#) for a description of the general configuration process.

The measured value can be supervised on limit violation and output through:

- Current outputs
- Modbus communication
- OPC UA communication

Digital alarm outputs can be used for indication of limit violation.

Procedure

1. Select the application in the **New Configuration** dialog.
 - a) Click **Two separate channels** to open the two channel application list.
 - b) Select **Cylinder pressure** for the appropriate channel.
 - c) Click **Create Configuration**.

2. Enter parameters.

See [Table 9-33](#) for an example configuration of a single channel cylinder pressure measurement with a static pressure sensor installed close to the suction valve. The compressor is a single chamber compressor. Only the significant parameters for the measurements are listed. The measuring range is defined by the selected sensor.

Table 9-33: Cylinder pressure – example configuration

Configuration page	Parameter	Value
Input 1	Sensor	Bently 165855-x1
Measurement 1	Evaluation	Suction pressure
	Chamber	Head side (chamber 2)
	Measuring range [kPa]	600

Table 9-33: Cylinder pressure – example configuration (continued)

Configuration page	Parameter	Value
	Piston angle [°]	45
	Tacho	Key 1
	Nominal speed [rpm]	270
	Stroke length [mm]	290
	Connection rod length [mm]	770
	Piston weight [kg]	145
	Crosshead weight [kg]	195
	Piston diameter [mm]	302
	Piston rod diameter [mm]	95
	Tail rod diameter [mm]	95
	Ambient pressure [kPa]	101.325
	Rod load	At crosshead pin
Current output 1	Current output	4 -20 mA
	Current suppression ¹	Box checked

¹ Optional parameter

- Click **Send & close** to send the configuration to the card.

9.1.14 Vibration (low frequency) with order analysis

In this mode, both channels of the A6500-UM Universal Measurement Card are operating independently of each other. One or both channels can be used to measure the radial shaft displacement at low machine speed. The lower cutoff frequency can be set in a range of 0.01 to 0.2 Hz. For this application, the analysis function **Order analysis including Peak Phase** (see [Analysis 1](#) and [Analysis 2](#)) is activated by default. See [Table 9-34](#) for signal evaluation details.

Table 9-34: Signal evaluation

Sensor type	Signal evaluation	Unit	Description
Eddy current	0-to-peak	µm or mil	The measurement value is proportional to the radial shaft displacement at low machine speed in 0-to-peak evaluation.
	peak-to-peak		The measurement value is proportional to the radial shaft displacement at low machine speed in peak-to-peak evaluation.

Table 9-34: Signal evaluation (continued)

Sensor type	Signal evaluation	Unit	Description
	RMS ¹		The measurement value is proportional to the radial shaft displacement at low machine speed in RMS ¹ evaluation.

¹ Root Mean Square

Note

A key signal is recommended for this measurement application.

Sensor adjustment

See [Sensor adjustment](#).

Card configuration

Note

See [General configuration procedure](#) for description of the general configuration process.

The value of measured low frequency movement of the shaft in radial direction can be supervised on limit violations and output through:

- Current outputs
- Modbus communication
- OPC UA communication

Digital alarm outputs can be used for indication of limit violation. Limits can be defined for peak and phase, and for overall values.

Procedure

1. Select the application in the **New Configuration** dialog.
 - a) Click **Two separate channels** to open the two channel application list.
 - b) Select **Vibration (low frequency) with order analysis** for the appropriate channel.
 - c) Click **Create Configuration**.

2. Enter parameters.

See [Table 9-35](#) for an example configuration of a single channel shaft bending measurement with an eddy current measuring chain consisting of a PR 6423/xxx-xxx and a CON 011 with a converter output voltage range of -2 V to -18 V. Only significant parameters are listed.

Table 9-35: Vibration (low frequency) with order analysis – example configuration

Configuration page	Parameter	Value
Input 1	Sensor	PR 6423

Table 9-35: Vibration (low frequency) with order analysis – example configuration (continued)

Configuration page	Parameter	Value
	Converter	CON 011 -2/-18 V
Measurement 1	Tacho	Key 1
	Evaluation	Displacement P-P
	Measuring range [μm]	125
	Nominal speed [RPM]	3000
Current output 1	Current output	4 - 20 mA
	Current suppression ¹	Box checked
Analysis 1	Select analysis	Order analysis including Peak Phase ²
	Na Order	1st Order
	Nb Order	2nd Order
	Nc Order	3rd Order
	Nd Order	4th Order
	Ne Order	5th Order
Alarm limits 1	Enabled	Box checked
	Danger alarm [μm]	110
	Alert alarm [μm]	95
	Alarm hysteresis [μm]	5
	Latching	Box not checked
	Limit suppression	Box checked
	Peak Phase Enabled	Box not checked

¹ Optional Parameter

² Selected by default.

3. Click **Send & close** to send the configuration to the card.

9.2 Combined channel applications

9.2.1 Combined channels – shaft vibration S_{max}

In this mode both channels of the A6500-UM Universal Measurement Card are combined for measure and calculate the relative shaft vibration S_{max} .

The measurement requires two eddy current measuring chains of the same type, which are mounted with a radial offset of 90°. Through geometrical addition of the momentary vibration values of channel 1 (S_1) and channel 2 (S_2), the maximum value of the resulting shaft vibration in 0-to-peak is calculated with the following formula:

$$S_{\max} = \sqrt{S_1^2 + S_2^2}$$

Figure 9-30 shows a sensor arrangement example with two eddy current sensors mounted into the bearing.

Figure 9-30: Sensor arrangement example – shaft vibration S_{\max}

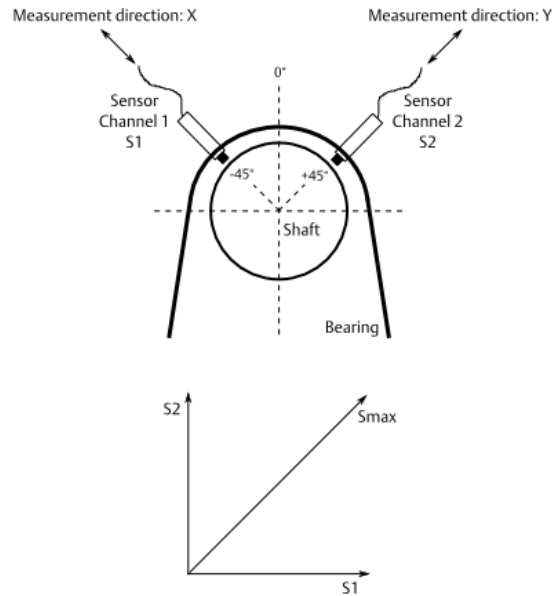

Sensor adjustment

Emerson recommends eddy current measuring chains consisting of the listed sensors and converters (see [Table 9-36](#)).

Table 9-36: Recommended sensors and converters

Sensors and converters
Sensors
EZ 105x-xx-xx-xxx ¹
EZ 108x-xx-xx-xxx ¹
PR 6422/xxx-xxx ¹
PR 6423/xxx-xxx ¹
PR 6424/xxx-xxx
PR 6425/xxx-xxx
Converters
EZ 1000
CON 011
CON 021

Table 9-36: Recommended sensors and converters (continued)

Sensors and converters
CON 031
CON 041

¹ Standard for shaft vibration measurement

The sensor must be set to the center of its static measuring range by measuring the converter output voltage.

Note

When adjusting the center position, consider the lifting of the shaft caused by the oil film thickness. Applies to machines with sleeve bearings.

1. Switch on the power supply of the System Rack in which the Universal Measurement Card is installed.
2. Measure the output voltage of the measuring chain with a DC voltmeter on the terminals OUT and ⊥ (GND) of the converter.
3. Adjust the distance between sensor and shaft so that the measured converter output voltage is in the center of the voltage range (for example, -2 to -18 V) approximately -10 V.
4. Fix the sensor in that position.

Repeat these steps for the second channel.

See operation manual of the sensor used for further installation details.

Card configuration

Note

See [General configuration procedure](#) for description of the general configuration process.

The measured vibration value can be supervised on limit violation and output through:

- Current outputs.
- Modbus communication of the A6500-CC Com Card.
- OPC UA communication of the A6500-CC Com Card.

Digital alarm outputs can be used for indication of limit violation.

Select the appropriate application from the "New Configuration" window.

1. Click **Calculation based on two channels** to open the application list.
2. Select **Relative Shaft Vibration**.
3. Enter the parameters.

See [Table 9-37](#) for an example configuration of a shaft vibration S_{max} measurement with two eddy current measuring chains consisting of a PR 6423/xxx-xxx and a CON 011 with a converter output voltage range of -2 V to -18 V. Only significant parameters are listed.

Table 9-37: Shaft vibration S_{max} – example configuration

Configuration page	Parameter	Value
Input 1	Sensor	PR 6423
	Converter	CON 011 -2/-18V
Input 2	Sensor	PR 6423
	Converter	CON 011 -2/-18V
Measurement	Evaluation	Smax
	Measuring range [μm]	150
	Tacho	Key 1
	Nominal speed [RPM]	3000
Current output 1	Current output	4 -20 mA
	Current suppression ¹	Box checked
Current output 1	Current output	4 -20 mA
	Current suppression ¹	Box checked
Alarm limits 1	Enabled	Box checked
	Danger alarm [μm]	120
	Alert alarm [μm]	90
	Alarm hysteresis [μm]	1.5
	Limit suppression	Box checked
Alarm limits 2	Enabled	Box not checked

¹ Optional parameter

- Click **Send & close** to send the configuration to the card.

9.2.2 Combined channels – shaft vibration S_{maxPP}

In this mode both channels of the A6500-UM Universal Measurement Card are combined for measure and calculate the greater shaft vibration amplitude out of two channels.

The measurement requires two eddy current measuring chains of the same type, which are mounted with a radial offset of 90°. The result of the channel combination is the higher measurement value of channel 1 (S_1) and channel 2 (S_2) in X and Y measurement direction in peak-to-peak. Formula:

$$S_{maxPP} = \max(S_1, S_2)$$

Figure 9-31 shows a sensor arrangement example with two eddy current sensors mounted into the bearing.

Figure 9-31: Sensor arrangement example – shaft vibration $S_{\max PP}$

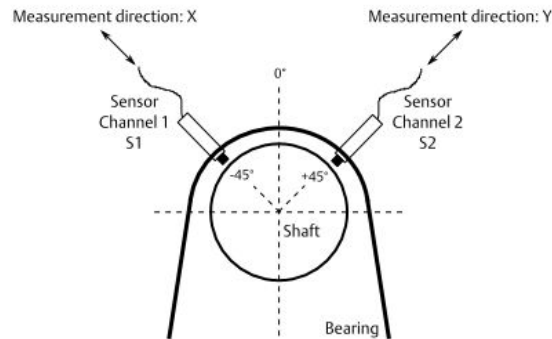

Sensor adjustment

Emerson recommends eddy current measuring chains consisting of the listed sensors and converters (see [Table 9-38](#)).

Table 9-38: Recommended sensors and converters

Sensors and converters
Sensors
EZ 105x-xx-xx-xxx ¹
EZ 108x-xx-xx-xxx ¹
PR 6422/xxx-xxx ¹
PR 6423/xxx-xxx ¹
PR 6424/xxx-xxx
PR 6425/xxx-xxx
Converters
EZ 1000
CON 011
CON 021
CON 031
CON 041

¹ Standard for shaft vibration measurement

The sensor must be set to the center of its static measuring range by measuring the converter output voltage.

Note

When adjusting the center position, consider the lifting of the shaft caused by the oil film thickness. Applies to machines with sleeve bearings.

1. Switch on the power supply of the system rack in which the Universal Measurement Card is installed.

2. Measure the output voltage of the measuring chain with a DC voltmeter on the terminals OUT and \perp (GND) of the converter .
3. Adjust the distance between sensor and shaft so that the measured converter output voltage is in the center of the voltage range (for example, -2 to -18 V) approximately -10 V.
4. Fix the sensor in that position.

Repeat these steps for the second channel.

See operation manual of the sensor used for further installation details.

Card configuration

Note

See [General configuration procedure](#) for description of the general configuration process.

The measured vibration value can be supervised on limit violation and output through:

- Current outputs.
- Modbus communication of the A6500-CC Com Card.
- OPC UA communication of the A6500-CC Com Card.

Digital alarm outputs can be used for indication of limit violation.

Select the appropriate application from the "New Configuration" window.

1. Click **Calculation based on two channels** to open the application list.
2. Select **Relative Shaft Vibration**.
3. Enter the parameters.

See [Table 9-39](#) for an example configuration of a shaft vibration $S_{\max PP}$ measurement with two eddy current measuring chains consisting of a PR 6423/xxx-xxx and a CON 011 with a converter output voltage range of -2 V to -18 V. Only significant parameters are listed.

Table 9-39: Shaft vibration $S_{\max PP}$ – example configuration

Configuration page	Parameter	Value
Input 1	Sensor	PR 6423
	Converter	CON 011 -2/-18V
Input 2	Sensor	PR 6423
	Converter	CON 011 -2/-18V
Measurement	Evaluation	SmaxPP
	Measuring range [μm]	150
	Tacho	Key 1
	Nominal speed [RPM]	3000
Current output 1	Current output	4 -20 mA
	Current suppression ¹	Box checked

Table 9-39: Shaft vibration $S_{\max PP}$ – example configuration (continued)

Configuration page	Parameter	Value
Current output 1	Current output	4 -20 mA
	Current suppression ¹	Box checked
Alarm limits 1	Enabled	Box checked
	Danger alarm [μm]	120
	Alert alarm [μm]	90
	Alarm hysteresis [μm]	1.5
	Limit suppression	Box checked
Alarm limits 2	Enabled	Box not checked

¹ Optional parameter

- Click **Send & close** to send the configuration to the card.

9.2.3 Combined channels – shaft position Cone 1 and Cone 2

In this mode both channels of the A6500-UM Universal Measurement Card are combined for measuring and calculation of the relative shaft position, distance, expansion, and so on in the unit "mm" or "mil" ("mm" is used for the following example).

The Cone measurement works with a measurement sensor (channel 1) that measures the axial shaft axial movement on a conical measuring collar. A reference sensor (channel 2) is used to compensate the influence of the radial shaft movement, also measured by the measurement sensor. With this measuring arrangement, shaft displacements, greater than the actual measuring range of the sensor, can be measured.

These two cone measurement types (Cone 1 and Cone 2) differ by the arrangement of the sensors.

- At Cone 1, the reference sensor is arranged at the straight part of the shaft close to the cone in the same radial measuring direction (see [Figure 9-32](#)).
- At Cone 2, the reference sensor is arranged at the straight part of the shaft close to the cone in the opposite radial measuring direction (see [Figure 9-32](#)).

Measurement sensor and reference sensor are not required to have the same measuring range. They may be of different type. Configuration of the Universal Measurement Card and the sensor adjustment is the same for both types.

Figure 9-32: Differences Cone 1 and Cone 2

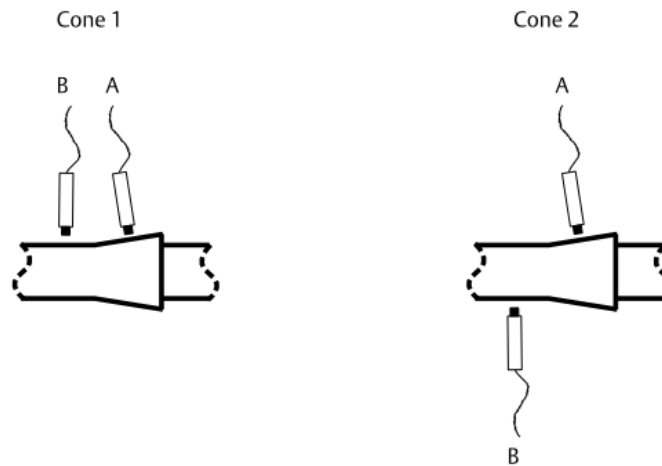

- A. Measurement sensor
- B. Reference sensor

Mechanical prerequisites

- The ramp angle of the cone must be within the range of $\geq 1^\circ$ to $\leq 45^\circ$.
- The ramp must have a uniform slope.
- The cone surface must be large enough that the sensor head with measurement surface extended by 45° (free space) can watch the angle of inclination over the entire displacement zone of the shaft (see [Sensor adjustment](#)).
- The sensors must be vertical to the measurement surface.
- For cone measurement, both sensors always remain in the operating range.

Measuring range definition

The maximum measuring range depends on the used sensor and cone angle:

$$\text{Range}_{\max} = \frac{\text{Measuring Range}_{\text{Sensor}}}{\sin \alpha}$$

α = cone angle

Example with cone angle of 9° and sensor measuring range of 4 mm:

$$\text{Range}_{\max} = \frac{4 \text{ mm}}{\sin 9} = 25.57 \text{ mm}$$

The usually small ramp angle of the cone results in a maximum measuring range, which is often greater than the maximum static measuring range of the used sensor (see [Figure 9-33](#)).

The used measuring range must be within the calculated maximum measuring range. Place the used measuring range so within the maximum range that there is a little distance

between the begin of the maximum range and the begin of the used measuring range. This enables shifting of the used measuring range for zero point correction in both directions.

Figure 9-33: Sensor arrangement and measurement example

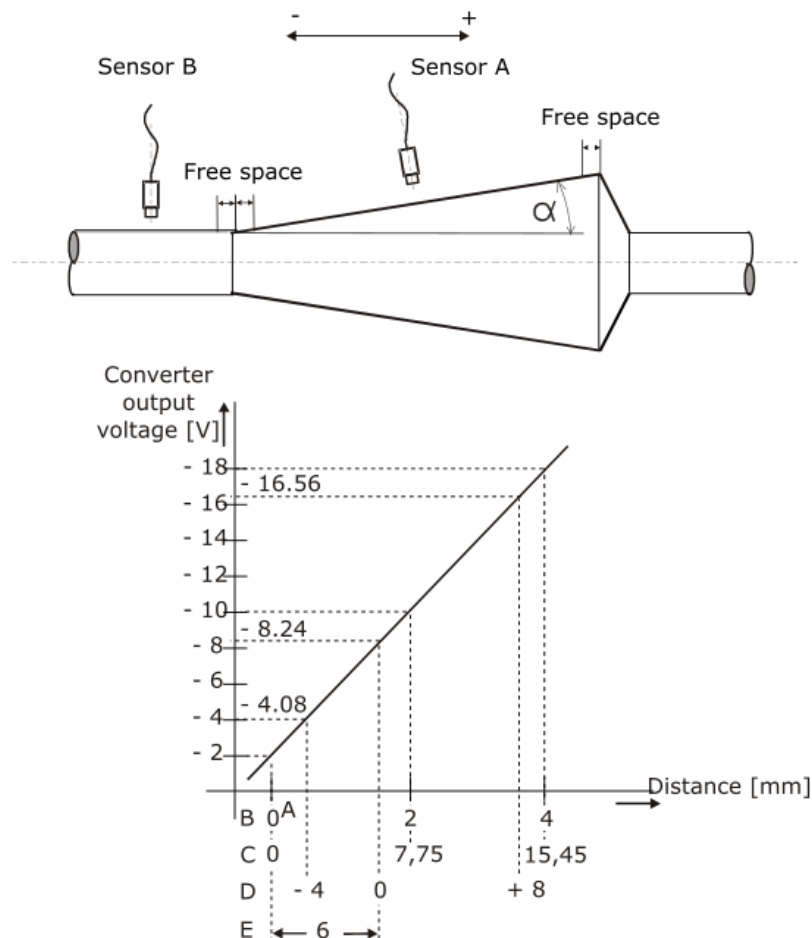

- A. Begin measuring range
- B. Measuring range PR 6424 0 to 4 mm (Sensor A)
- C. Maximum range with cone angle of 15°
- D. Used measuring range
- E. S_{zero} for the example measuring range

Table 9-40 shows the required minimum distance between sensor and the end or beginning of mechanical measuring range. For proper measurement ensure that the sensor does not move into these areas.

Table 9-40: Free space

Sensors	Minimum free space [mm]
PR 6422	6.3
PR 6423	11.0

Table 9-40: Free space (continued)

Sensors	Minimum free space [mm]
PR 6424	16.5
PR 6425	20.0
PR 6426	80.0

Sensor adjustment

Note

The position of the shaft must be known when adjusting the sensor.

Emerson recommends eddy current measuring chains consisting of the listed sensors and converter (see [Table 9-41](#)).

Table 9-41: Recommended sensors and converters

Sensors and converters
Sensors
EZ 105x-xx-xx-xxx
EZ 108x-xx-xx-xxx
PR 6422/xxx-xxx
PR 6423/xxx-xxx
PR 6424/xxx-xxx
PR 6425/xxx-xxx
PR 6426/xxx-xxx
Converters
EZ 1000
CON 011
CON 021
CON 031
CON 041

Note

If the sensors are mounted close together, the measuring chains can influence each other. In this case one measuring chain must be detuned. See respective converter operation manual.

Used values for example:

- Cone angle: 15°
- Sensor measuring range of PR 6424: 4 mm
- Converter output voltage range: -2 to -18 V
- S_{zero} : 6 mm

- Maximum sensor displacement: 15.45 mm (at cone angle = 15° and sensor PR 6424).
- Required measuring range: 12 mm in the range -4 mm to +8 mm.

Measurement sensor A

1. Define the needed measuring range.

Figure 9-34 shows an example measuring range of -4 mm to +8 mm within the maximum measuring range of approximately 15 mm.

Figure 9-34: Measuring range diagram with example values

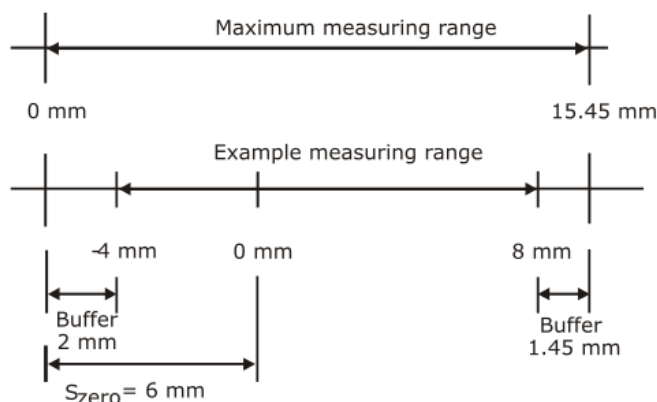

S_{zero} : Distance between the beginning of measuring range and zero position of the range or other defined shaft position.

The zero point is specified with parameter **Shift** in configuration page **Measurement**. In order for sufficient “space” to be available for a possible zero point correction, the measuring range beginning should not start directly on the lower voltage value (-2 V). This would be the case if -4 mm were entered as “Shift” parameter. A useful value for the offset is 6 mm. Thus, a buffer of 2 mm remains for a downward zero point offset. Because the desired measuring range is 12 mm and the maximum sensor displacement is 15.45 mm, a buffer of 1.45 mm remains for an upward zero point offset.

2. Calculate the sensor adjustment voltage depending on the needed measuring range.

For adjustment of the measurement sensor (Sensor A) the zero point voltage must be determined with the following formula. The zero point voltage of the reference sensor (Sensor B) is -10 V.

$$U_{zero} = \frac{(U_{SensorEnd} - U_{SensorStart}) * \sin \alpha * S_{zero}}{S_{MeasuringRange}} + U_{SensorStart}$$

Example:

$$U_{zero} = \frac{((-18 \text{ V}) - (-2 \text{ V})) * \sin 15 * 6 \text{ mm}}{4 \text{ mm}} + (-2 \text{ V}) = -8.21 \text{ V}$$

At the zero position of the shaft, the distance between measuring sensor and measuring object must be set so that the converter output voltage is -8.21 V.

3. Switch on the power supply of the system rack in which the Universal Measurement Card is installed.
4. Measure the output voltage of the measuring chain on the terminals OUT and \perp (GND) of the converter with a DC voltmeter.
5. Adjust the distance between sensor and measurement object so that the connected DC voltmeter displays the calculated adjustment voltage (U_{zero}).
6. Fix the sensor in that position. Ensure that the adjusted distance does not change during fixing the sensor.

Reference sensor B

Note

When adjusting the sensor, consider the lifting of the shaft caused by the oil film thickness. Applies to machines with sleeve bearings.

1. Switch on the power supply of the System Rack in which the Universal Measurement Card is installed.
2. Measure the output voltage of the measuring chain with a DC voltmeter on the terminals OUT and \perp (GND) of the converter.
3. Adjust the distance between the sensor and the measurement object (shaft) so that at zero position and radial mid-position of the shaft the measured converter output voltage is in the middle of the voltage range (for example, CON 011: -2 to -18 V, voltage at mid range: -10 V).
4. Fix the sensor in that position. Ensure that the adjusted distance does not change during fixing the sensor.

See operation manual of the used sensor for further installation details.

Card configuration

Creating the configuration:

Note

See [General configuration procedure](#) for description of the general configuration process.

The measured position value can be supervised on limit violation and output through:

- Current outputs.
- Modbus communication of the A6500-CC Com Card.
- OPC UA communication of the A6500-CC Com Card.

Digital alarm outputs can be used for indication of limit violation.

Select the appropriate application from the "New Configuration" window.

1. Click **Calculation based on two channels** to open the application list.
2. Select **Tandem/Cone**.
3. Enter the parameters.

See [Table 9-42](#) for an example configuration of a shaft position measurement with an eddy current measuring chain consisting of a measurement sensor PR 6424/xxx-

xxx and a CON 011 with a converter output voltage range of -2 V to -18 V and a reference sensor PR 6423/xxx-xxx and a CON 011 with a converter output voltage range of -2 V to -18 V. Only significant parameters are listed.

Table 9-42: Shaft position, Cone measurement – example configuration

Configuration page	Parameter	Value
Input 1	Sensor	PR 6424
	Converter	CON 011 -2/-18V
Input 2	Sensor	PR 6423
	Converter	CON 011 -2/-18V
Linearization 1	Line 1 [V] / [mm]	-18 / 4
	Line 2 [V] / [mm]	-2 / 0
Linearization 2	Line 1 [V] / [mm]	-18 / 1
	Line 2 [V] / [mm]	-2 / -1
Measurement	Evaluation	Cone 1
	Begin [mm]	-4
	End [mm]	8
	Shift [mm]	6
	Ramp angle [°]	15
	Tacho	Time
Current output 1	Current output	4 - 20 mA
	Current suppression ¹	Box checked
Current output 1	Current output	4 - 20 mA
	Current suppression ¹	Box checked
Alarm limits 1	Enabled	Box checked
	Upper danger alarm [mm]	6.8
	Upper alert alarm [mm]	5.6
	Lower alert alarm [mm]	-1.6
	Lower danger alarm [mm]	-2.8
	Alarm hysteresis [mm]	0.1
	Limit suppression	Box checked
Alarm limits 2	Enabled	Box not checked

¹ Optional parameter

4. Click **Send & close** to send the configuration to the card.

Zero point correction

If the converter output voltage cannot be set precisely on the zero point voltage or another defined voltage use the parameter **Shift** on page **Measurement** for correction.

1. Complete the following formula with S_{zero} and measured value shown by the online view.

$$S_{zero\ corrected} = S_{zero} + Value_{displayed}$$

Example with $Value_{Display}$ is 0.03 mm and S_{zero} is 6 mm (see parameter: Shift):

$$S_{zero\ correction} = 6.0\text{ mm} + 0.03\text{ mm} = 6.03\text{ mm}$$

2. Enter the new calculated value for the parameter **Shift**.
3. Send the configuration to the card.
4. Now, the online view shows 0.00 mm.

Note

The current output will be adjusted accordingly.

Measuring range check

Check the measuring range after completing sensor adjustment and configuration. This can be done by shifting the measuring object (if possible) or the common sensor holder through the measuring range. For reference, the converter output voltage related to the position value of sensor A can be calculated with the following formula. For example values see [Table 9-43](#).

$$U_{OutputVoltage} = U_{SensorStart} + \frac{(U_{SensorEnd} - U_{SensorStart}) * \sin \alpha * n}{S_{MeasuringRange}}$$

n: Position

Example:

- Cone angle (α): 15°
- Sensor measuring range ($S_{MeasuringRange}$): 4 mm
- Converter output voltage range: -2 V ($U_{SensorStart}$) to -18 V ($U_{SensorEnd}$)
- n: 0 to 15 mm
- Configured measuring range: -4 to +8 mm

$$U_{OutputVoltage} = -2\text{ V} + \frac{(-18\text{ V} - (-2\text{ V})) * \sin 15 * n}{4\text{ mm}}$$

Table 9-43: Measuring range check - Cone measurement

n [mm]	$U_{OutputVoltage}$ [V]	Online view [mm] ¹
0	-2.00	
1	-3.04	

Table 9-43: Measuring range check - Cone measurement (continued)

n [mm]	U _{OutputVoltage} [V]	Online view [mm] ¹
2	-4.07	-4
3	-5.11	-3
4	-6.14	-2
5	-7.18	-1
6	-8.21	0
7	-9.25	1
8	-10.28	2
9	-11.32	3
10	-12.35	4
11	-13.39	5
12	-14.42	6
13	-15.46	7
14	-16.49	8
15	-17.53	

¹ Without zero point correction

1. Measure the converter output voltage of the measurement sensor (sensor A) on terminals OUT and GND. Use a DC voltmeter.
2. Set the calculated converter output voltages as shown in Table 9-43 when passing through the measuring range.
3. Compare the displayed value with the values shown in Table 9-43. For example, -4.07 V corresponds to -4 mm. The converter output voltage of the reference sensor channel (sensor B) must be -10 V.

9.2.4 Combined channels – shaft position Double Cone 1

In this mode both channels of the A6500-UM Universal Measurement Card are combined for measure and calculate the relative shaft position, distance, expansion, and so on in the unit "mm" or "mil" ("mm" is used for the following example).

The Double Cone 1 measurement measures the axial shaft movement with two sensors that are arranged with a 180° offset at a conical measuring collar. The radial movement of the shaft is compensated by this sensor arrangement. With this measuring arrangement, shaft displacements, greater than the actual measuring range of the sensor, can be measured.

Both measuring chains must be of same type and must have the same channel configuration.

Mechanical prerequisites

- The ramp angle of the cone must be within the range of $\geq 1^\circ$ to $\leq 45^\circ$.
- The ramp must have a uniform slope.
- The cone surface must be large enough that the sensor head with measurement surface extended by 45° (free space) can watch the angle of inclination over the entire displacement zone of the shaft (see [Figure 9-35](#)).
- The sensors must be vertical to the measurement surface.
- For cone measurement, both sensors always remain in the operating range.

Measuring range definition

The maximum measuring range depends on the sensor used and cone angle:

$$\text{Range}_{\max} = \frac{\text{Measuring Range}_{\text{Sensor}}}{\sin \alpha}$$

α = cone angle

Example with cone angle of 9° and sensor measuring range of 4 mm:

$$\text{Range}_{\max} = \frac{4 \text{ mm}}{\sin 9} = 25.57 \text{ mm}$$

The usually small ramp angle of the cone results in a maximum measuring range which is often greater than the maximum static measuring range of the used sensor (see [Figure 9-35](#)).

The used measuring range must be within the calculated maximum measuring range. Place the measuring range used so that within the maximum range there is a small distance between the beginning of the maximum range and the beginning of the measuring range used. This enables shifting of the used measuring range for zero point correction in both directions.

Figure 9-35: Sensor arrangement Double Cone 1 and measurement example

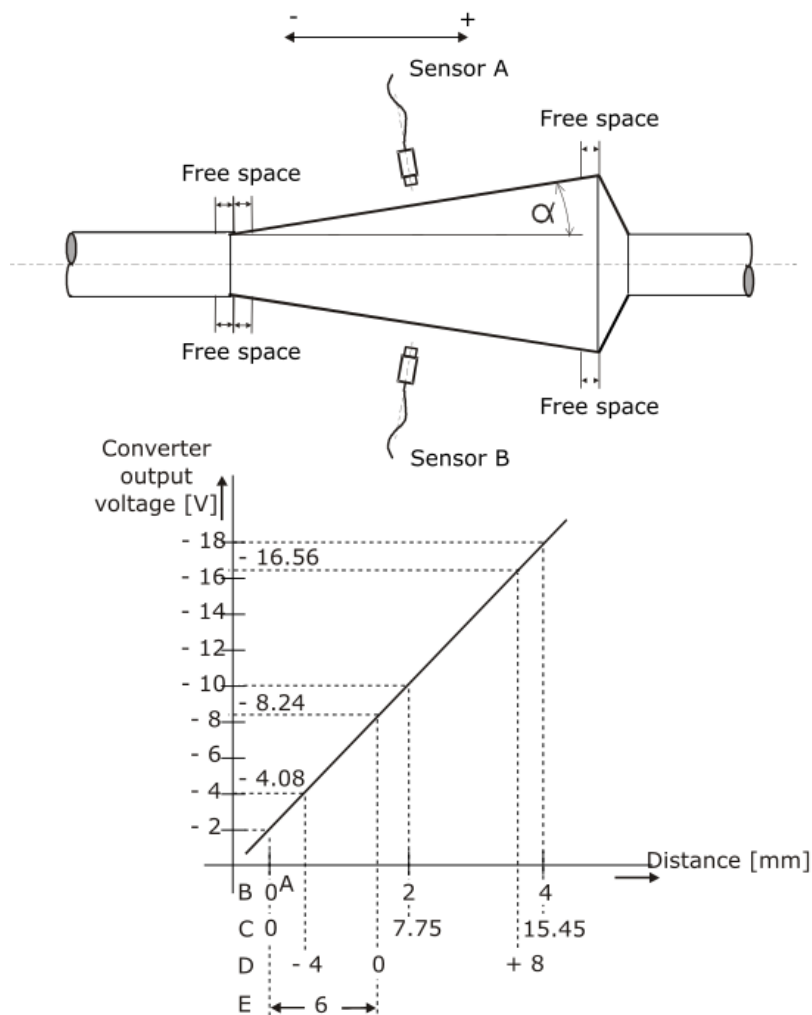

- A. Begin measuring range
- B. Measuring range PR 6424 0 to 4 mm (Sensor A)
- C. Maximum range with cone angle of 15°
- D. Measuring range used
- E. S_{zero} for the example measuring range (zero point definition)

Table 9-44 shows the required minimum distance between sensor and end or beginning of mechanical measuring range. For proper measurement ensure that the sensor does not move into these areas.

Table 9-44: Free space

Sensors	Minimum free space [mm]
PR 6422	6.3
PR 6423	11.0
PR 6424	16.5

Table 9-44: Free space (continued)

Sensors	Minimum free space [mm]
PR 6425	20.0
PR 6426	80.0

Sensor adjustment

Note

The position of the shaft must be known when adjusting the sensor.

Emerson recommends eddy current measuring chains consisting of the listed sensors and converters (see [Table 9-45](#)).

Table 9-45: Recommended sensors and converters

Sensors and converters
Sensors
EZ 105x-xx-xx-xxx
EZ 108x-xx-xx-xxx
PR 6422/xxx-xxx
PR 6423/xxx-xxx
PR 6424/xxx-xxx
PR 6425/xxx-xxx
PR 6426/xxx-xxx
Converters
EZ 1000
CON 011
CON 021
CON 031
CON 041

Note

If the sensors are mounted close together, the measuring chains can influence each other. In this case one measuring chain must be detuned. See respective converter operation manual.

Used values for example:

- Cone angle: 15°
- Sensor measuring range of PR 6424: 4 mm
- Converter output voltage range: -2 to -18 V
- S_{zero} : 6 mm
- Maximum sensor displacement: 15.45 mm (at cone angle = 15° and sensor PR 6424).

- Required measuring range: 12 mm in the range of -4 mm to +8 mm.
 1. Define the needed measuring range.
Figure 9-36 shows an example measuring range of -4 mm to +8 mm within the maximum measuring range of approximately 15 mm.

Figure 9-36: Measuring range diagram with example values

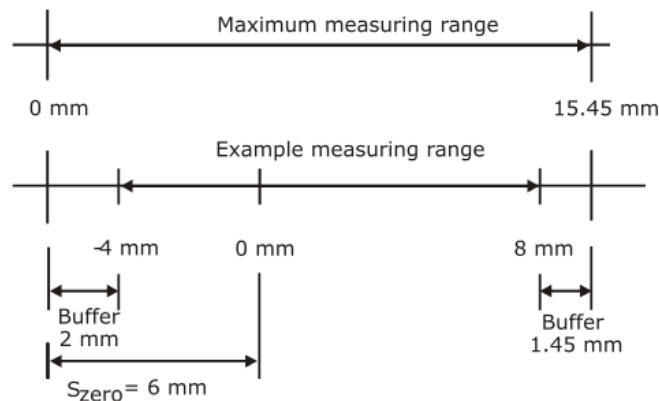

S_{zero} : Distance between beginning of measuring range and zero position of the range or other defined shaft position.

The zero point is specified with parameter **Shift** on configuration page **Measurement**. In order for sufficient “space” to be available for a possible zero point correction, the measuring range beginning should not start directly on the lower voltage value (-2 V). This would be the case if -4 mm were entered as **Shift** parameter. A useful value for the offset is 6 mm. Thus, a buffer of 2 mm remains for a downward zero point offset. Because the desired measuring range is 12 mm and the maximum sensor displacement is 15.45 mm, a buffer of 1.45 mm remains for an upward zero point offset.

2. Calculate the sensor adjustment voltage depending on the needed measuring range.
For adjustment of both sensors (sensor A and sensor B) the zero point voltage must be determined with the following formula.

$$U_{zero} = \frac{(U_{SensorEnd} - U_{SensorStart}) * \sin \alpha * S_{zero}}{S_{MeasuringRange}} + U_{SensorStart}$$

Example:

$$U_{zero} = \frac{(-18 \text{ V} - (-2 \text{ V})) * \sin 15 * 6 \text{ mm}}{4 \text{ mm}} + (-2 \text{ V}) = -8.21 \text{ V}$$

At the zero position of the shaft, the distance between each sensor and the measuring object must be set so that the converter output voltage is -8.21 V.

3. Switch on the power supply of the system rack in which the Universal Measurement Card is installed.

4. Measure the output voltage of the measuring chain with a DC voltmeter on the terminals OUT and \perp (GND) of the converter.
5. Adjust the distance between sensor and measurement object so that the connected DC voltmeter displays the calculated adjustment voltage (U_{zero}).
6. Fix the sensor in that position. Ensure that the adjusted distance does not change during fixing the sensor.

Repeat these steps for the second sensor.

See operation manual of the sensor used for further installation details.

Card configuration

Creating the configuration:

Note

See [General configuration procedure](#) for description of the general configuration process.

The measured position value can be supervised on limit violation and output through:

- Current outputs.
- Modbus communication of the A6500-CC Com Card.
- OPC UA communication of the A6500-CC Com Card.

Digital alarm outputs can be used for indication of limit violation.

Select the appropriate application from the "New Configuration" window.

1. Click **Calculation based on two channels** to open the application list.
2. Select **Tandem/Cone**.
3. Enter the parameters.

See [Table 9-46](#) for an example configuration of a shaft position measurement with two eddy current measuring chains consisting of a PR 6424/xxx-xxx and a CON 011 with a converter output voltage range of -2 V to -18 V. Only significant parameters are listed.

Table 9-46: Shaft position, Double Cone 1 measurement – example configuration

Configuration page	Parameter	Value
Input 1	Sensor	PR 6424
	Converter	CON 011 -2/-18V
Input 2	Sensor	PR 6424
	Converter	CON 011 -2/-18V
Linearization 1	Line 1 [V] / [mm]	-18 / 4
	Line 2 [V] / [mm]	-2 / 0
Linearization 2	Line 1 [V] / [mm]	-18 / 4
	Line 2 [V] / [mm]	-2 / 0

Table 9-46: Shaft position, Double Cone 1 measurement – example configuration (continued)

Configuration page	Parameter	Value
Measurement	Evaluation	Double cone 1
	Begin [mm]	-4
	End [mm]	8
	Shift [mm]	6
	Ramp angle [°]	15
	Tacho	Time
Current output 1	Current output	4 -20 mA
	Current suppression ¹	Box checked
Current output 1	Current output	4 -20 mA
	Current suppression ¹	Box checked
Alarm limits 1	Enabled	Box checked
	Upper danger alarm [mm]	6.8
	Upper alert alarm [mm]	5.6
	Lower alert alarm [mm]	-1.6
	Lower danger alarm [mm]	-2.8
	Alarm hysteresis [mm]	0.1
	Limit suppression	Box checked
Alarm limits 2	Enabled	Box not checked

¹ Optional parameter

- Click **Send & close** to send the configuration to the card.

Zero point correction

If the converter output voltage cannot be set precisely on the zero point voltage or a another defined voltage use the parameter **Shift** on configuration page **Measurement** for correction.

- Complete following formula with S_{zero} and measured value shown by the online display.

$$S_{zero\ corrected} = S_{zero} + Value_{displayed}$$

Example with $Value_{Display}$ is 0.03 mm and S_{zero} is 6 mm (see parameter: Offset):

$$S_{zero\ corrected} = 6.0\text{ mm} + 0.03\text{ mm} = 6.03\text{ mm}$$

- Enter the new calculated value for the parameter **Shift**.
- Send the configuration to the card.

- The online display shows 0.00 mm.

Note

The current output will be adjusted accordingly.

Measuring range check

Check the measuring range after completing sensor adjustment and configuration. This can be done by shifting the measuring object (if possible) or the common sensor holder through the measuring range. For reference, the converter output voltage of both measuring chains related to the position value can be calculated with the following formula.

$$U_{\text{OutputVoltage}} = U_{\text{SensorStart}} + \frac{(U_{\text{SensorEnd}} - U_{\text{SensorStart}}) * \sin \alpha * n}{S_{\text{MeasuringRange}}}$$

n: Position

Example:

- Cone angle (α): 15°
- Sensor measuring range ($S_{\text{MeasuringRange}}$): 4 mm
- Converter output voltage range: -2 V ($U_{\text{SensorStart}}$) to -18 V ($U_{\text{SensorEnd}}$)
- n: 0 to 15 mm
- Configured measuring range: -4 to +8 mm

$$U_{\text{OutputVoltage}} = -2 \text{ V} + \frac{(-18 \text{ V} - (-2 \text{ V})) * \sin 15 * n}{4 \text{ mm}}$$

Table 9-47: Measuring range check - Double Cone 1 measurement

n [mm]	$U_{\text{OutputVoltage}}$ [V], (Sensor A)	$U_{\text{OutputVoltage}}$ [V], (Sensor B)	Online view [mm] ¹
0	-2.00	-2.00	
1	-3.04	-3.04	
2	-4.07	-4.07	-4
3	-5.11	-5.11	-3
4	-6.14	-6.14	-2
5	-7.18	-7.18	-1
6	-8.21	-8.21	0
7	-9.25	-9.25	1
8	-10.28	-10.28	2
9	-11.32	-11.32	3
10	-12.35	-12.35	4

Table 9-47: Measuring range check - Double Cone 1 measurement (continued)

n [mm]	U _{OutputVoltage} [V], (Sensor A)	U _{OutputVoltage} [V], (Sensor B)	Online view [mm] ¹
11	-13.39	-13.39	5
12	-14.42	-14.42	6
13	-15.46	-15.46	7
14	-16.49	-16.49	8
15	-17.53	-17.53	

¹ Without zero point correction

1. Measure the converter output voltage of both measuring chains (sensor A and sensor B) on terminals OUT and GND. Use a DC voltmeter.
2. Set the calculated converter output voltages as shown in [Table 9-47](#) when passing through the measuring range.
3. Compare the displayed value with the values shown in [Table 9-47](#). For example, sensor A: -5.11 V and sensor B: -5.11 corresponds to -3 mm.

9.2.5 Combined channels – shaft position Double Cone 2

In this mode both channels of the A6500-UM Universal Measurement Card are combined for measure and calculate the relative shaft position, distance, expansion, and so on in the unit "mm" or "mil" ("mm" is used for the following example).

The Double Cone 2 measurement measures the axial shaft movement with two sensors that are arranged at a dual-side conical measuring collar. The radial movement of the shaft is compensated by this sensor arrangement. With this measuring arrangement, shaft displacements, greater than the actual measuring range of the sensor, can be measured.

Both measuring chains must be of same type and must have the same channel configuration.

Mechanical prerequisites

- The ramp angle of the dual-side cone must be within the range of $\geq 1^\circ$ to $\leq 45^\circ$. Same angle at both sides.
- The ramp must have a uniform slope.
- The cone surface must be large enough that the sensor head with measurement surface extended by 45° (free space) can watch the angle of inclination over the entire displacement zone of the shaft (see [Sensor adjustment](#)).
- The sensors must be vertical to the measurement surface.
- For cone measurement, both sensors always remain in the operating range.

Measuring range definition

The maximum measuring range depends on the sensor used and cone angle:

$$\text{Range}_{\max} = \frac{\text{Measuring Range}_{\text{Sensor}}}{\sin \alpha}$$

α = cone angle

Example with cone angle of 9° and sensor measuring range of 4 mm:

$$\text{Range}_{\max} = \frac{4 \text{ mm}}{\sin 9} = 25.57 \text{ mm}$$

The usually small ramp angle of the cone results in a maximum measuring range, which is often greater than the maximum static measuring range of the sensor used (see [Figure 9-37](#)).

The measuring range used must be within the calculated maximum measuring range. Place the measuring range used so that within the maximum range there is a little distance between the beginning of the maximum range and the beginning of the measuring range used. This enables shifting of the used measuring range for zero point correction in both directions.

Figure 9-37: Sensor arrangement Double Cone 2 and measurement example

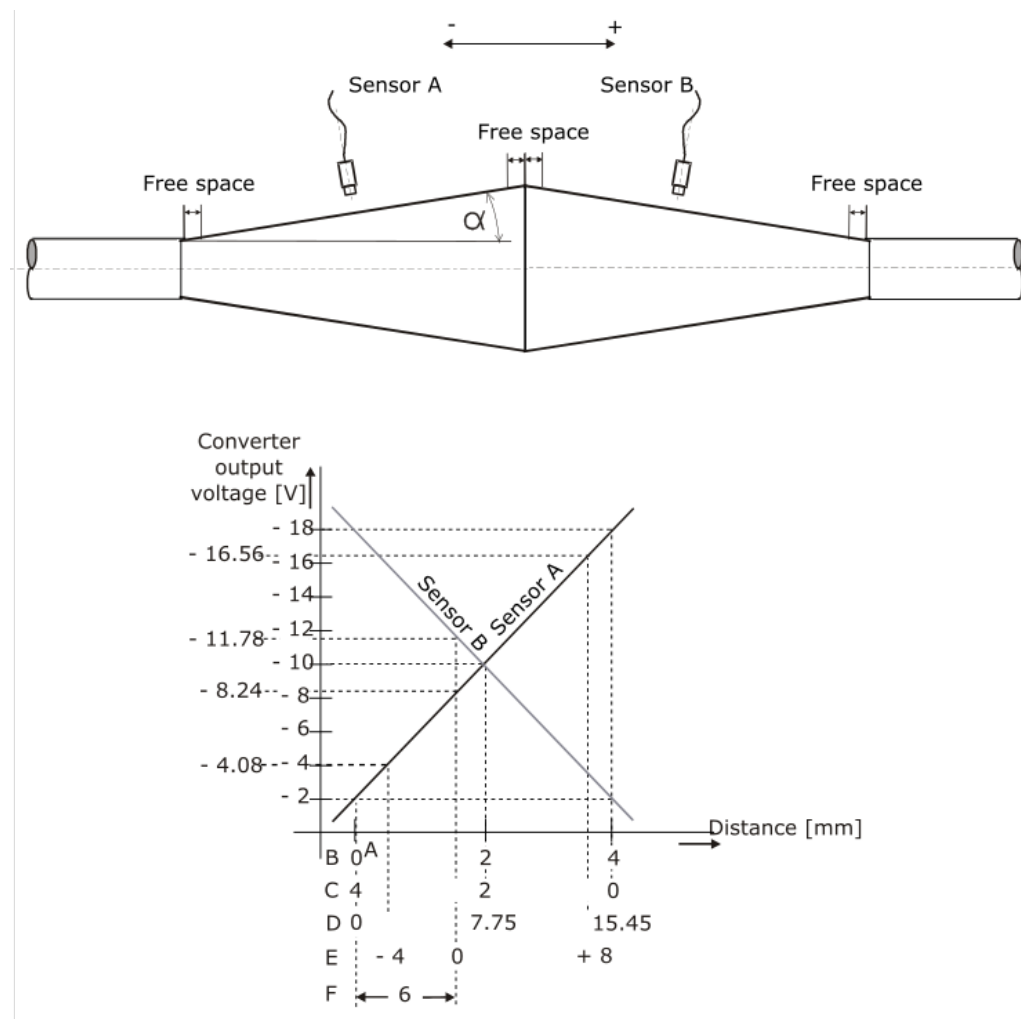

- A. Begin measuring range
- B. Measuring range PR 6424 0 to 4 mm (Sensor A)
- C. Measuring range PR 6424 0 to 4 mm (Sensor B)
- D. Maximum range with cone angle of 15°
- E. Measuring range used
- F. S_{zero} for the example measuring range (zero point definition)

Table 9-48 shows the required minimum distance between the sensor and end or beginning of the mechanical measuring range. For proper measurement ensure that the sensor does not move into these areas.

Table 9-48: Free space

Sensors	Minimum free space [mm]
PR 6422	6.3
PR 6423	11.0

Table 9-48: Free space (continued)

Sensors	Minimum free space [mm]
PR 6424	16.5
PR 6425	20.0
PR 6426	80.0

Sensor adjustment

Note

The position of the shaft must be known when adjusting the sensor.

Emerson recommends eddy current measuring chains consisting of the listed sensors and converters (see [Table 9-49](#)).

Table 9-49: Recommended sensors and converters

Sensors and converters
Sensors
EZ 105x-xx-xx-xxx
EZ 108x-xx-xx-xxx
PR 6422/xxx-xxx
PR 6423/xxx-xxx
PR 6424/xxx-xxx
PR 6425/xxx-xxx
PR 6426/xxx-xxx
Converters
EZ 1000
CON 011
CON 021
CON 031
CON 041

Note

If the sensors are mounted close together, the measuring chains can influence each other. In this case one measuring chain must be detuned. See respective converter operation manual.

Used values for example:

- Cone angle: 15°
- Sensor measuring range of PR 6424: 4 mm
- Converter output voltage range: -2 to -18 V
- S_{zero} : 6 mm

- Maximum sensor displacement: 15.45 mm (at cone angle = 15° and sensor PR 6424).
 - Required measuring range: 12 mm in the range of -4 mm to +8 mm.
1. Define the needed measuring range.

Figure 9-38 shows an example measuring range of -4 mm to +8 mm within the maximum measuring range of approximately 15 mm.

Figure 9-38: Measuring range diagram with example values

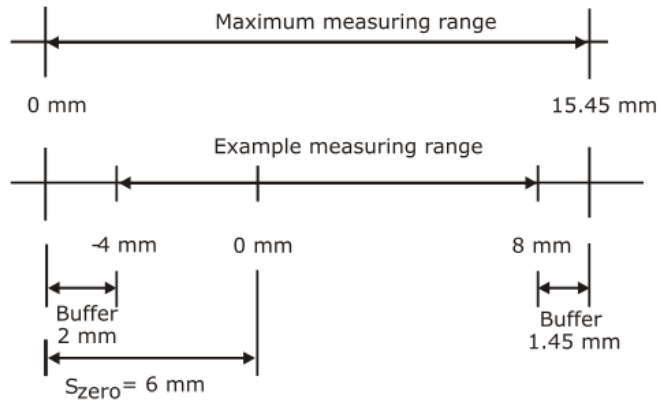

S_{zero} : Distance between beginning of measuring range and zero position of the range or other defined shaft position.

The zero point is specified with parameter **Shift** on configuration page **Measurement**. In order for sufficient “space” to be available for a possible zero point correction, the measuring range beginning should not start directly on the lower voltage value (-2 V). This would be the case if -4 mm were entered as **Shift** parameter. A useful value for the offset is 6 mm. Thus, a buffer of 2 mm remains for a downward zero point offset. Because the desired measuring range is 12 mm and the maximum sensor displacement is 15.45 mm, a buffer of 1.45 mm remains for an upward zero point offset.

2. Calculate the sensor adjustment voltage depending on the needed measuring range.
For adjustment of both sensors (sensor A and sensor B) the zero point voltage must be determined with the following formulas.

Sensor A:

$$U_{zero A} = \frac{(U_{SensorEnd A} - U_{SensorStart A}) * \sin \alpha * S_{zero}}{S_{MeasuringRange}} + U_{SensorStart A}$$

Example:

$$U_{zero A} = \frac{(-18 V - (-2 V)) * \sin 15 * 6 mm}{4 mm} + (-2 V) = -8.21 V$$

Sensor B:

$$U_{\text{zero B}} = U_{\text{SensorEnd B}} - \frac{(U_{\text{SensorEnd B}} - U_{\text{SensorStart B}}) * \sin \alpha * S_{\text{zero}}}{S_{\text{MeasuringRange}}}$$

Example:

$$U_{\text{zero B}} = -18 \text{ V} - \frac{(-18 \text{ V} - (-2 \text{ V})) * \sin 15^\circ * 6 \text{ mm}}{4 \text{ mm}} = -11.79 \text{ V}$$

At the zero position of the shaft, the distance between sensor A and the measuring object must be set so that the converter output voltage is -8.21 V. The distance between sensor B and the measuring object must be set so that the converter output is -11.79 V.

3. Switch on the power supply of the system rack in which the Universal Measurement Card is installed.
4. Measure the output voltage of the measuring chains with a DC voltmeter on the terminals OUT and \perp (GND) of the converter.
5. Adjust the distance between sensors and measurement object so that the connected DC voltmeter displays the calculated adjustment voltages ($U_{\text{zero A}}$ and $U_{\text{zero B}}$).
6. Fix the sensors in that position. Ensure that the adjusted distance does not change during fixing the sensor.

See operation manual of the sensor used for further installation details.

Card configuration

Creating the configuration:

Note

See [General configuration procedure](#) for description of the general configuration process.

The measured position value can be supervised on limit violation and output through:

- Current outputs.
- Modbus communication of the A6500-CC COM Card.
- OPC UA communication of the A6500-CC COM Card.

Digital alarm outputs can be used for indication of limit violation.

Select the appropriate application from the "New Configuration" window.

1. Click **Calculation based on two channels** to open the application list.
2. Select **Tandem/Cone**.
3. Enter the parameters.

See [Table 9-50](#) for an example configuration of a shaft position measurement with two eddy current measuring chains consisting of a PR 6424/xxx-xxx and a CON 011 with a converter output voltage range of -2 V to -18 V. Only significant parameters are listed.

Table 9-50: Shaft position, Double Cone 2 measurement – example configuration

Configuration page	Parameter	Value
Input 1	Sensor	PR 6424
	Converter	CON 011 -2/-18V
Input 2	Sensor	PR 6423
	Converter	CON 011 -2/-18V
Linearization 1	Line 1 [V] / [mm]	-18 / 4
	Line 2 [V] / [mm]	-2 / 0
Linearization 2	Line 1 [V] / [mm]	-18 / 4
	Line 2 [V] / [mm]	-2 / 0
Measurement	Evaluation	Double cone 2
	Begin [mm]	-4
	End [mm]	8
	Shift [mm]	6
	Ramp angle [°]	15
	Tacho	Time
Current output 1	Current output	4 -20 mA
	Current suppression ¹	Box checked
Current output 1	Current output	4 -20 mA
	Current suppression ¹	Box checked
Alarm limits 1	Enabled	Box checked
	Upper danger alarm [mm]	6.8
	Upper alert alarm [mm]	5.6
	Lower alert alarm [mm]	-1.6
	Lower danger alarm [mm]	-2.8
	Alarm hysteresis [mm]	0.1
	Limit suppression	Box checked
Alarm limits 2	Enabled	Box not checked

¹ Optional parameter

- Click **Send & close** to send the configuration to the card.

Zero point correction

If the converter output voltage cannot be set precisely on the zero point voltage or a another defined voltage use the parameter **Shift** on configuration page **Measurement** for correction.

1. Complete following formula with S_{zero} and measured value shown by the online display.

$$S_{\text{zero corrected}} = S_{\text{zero}} + \text{Value}_{\text{displayed}}$$

Example with $\text{Value}_{\text{Display}}$ is 0.03 mm and S_{zero} is 6 mm (see parameter: Shift):

$$S_{\text{zero corrected}} = 6.0 \text{ mm} + 0.03 = 6.03 \text{ mm}$$

2. Enter the new calculated value for the parameter **Shift**.
3. Send the configuration to the card.
4. The online display shows 0.00 mm.

Note

The current output will be adjusted accordingly.

Measuring range check

Check the measuring range after completing sensor adjustment and configuration. This can be done by shifting the measuring object (if possible) or the common sensor holder through the measuring range. For reference, the converter output voltage of both measuring chains related to the position value can be calculated with the following formulas (see Table 9-51) for values.

Sensor A

$$U_{\text{OutputVoltage A}} = U_{\text{SensorStart A}} + \frac{(U_{\text{SensorEnd A}} - U_{\text{SensorStart A}}) * \sin \alpha * n}{S_{\text{MeasuringRange}}}$$

Sensor B

$$U_{\text{OutputVoltage B}} = U_{\text{SensorEnd B}} - \frac{(U_{\text{SensorEnd B}} - U_{\text{SensorStart B}}) * \sin \alpha * n}{S_{\text{MeasuringRange}}}$$

n: Position

Example:

- Cone angle (Alpha): 15°
- Sensor measuring range ($S_{\text{MeasuringRange}}$, sensor A and sensor B): 4 mm
- Converter output voltage range: -2 V ($U_{\text{SensorStart}}$) to -18 V ($U_{\text{SensorEnd}}$)
- n: 0 to 15 mm
- Configured measuring range: -4 to +8 mm

$$U_{\text{OutputVoltage A}} = -2 \text{ V} + \frac{(-18 \text{ V} - (-2 \text{ V})) * \sin 15 * n}{4 \text{ mm}}$$

$$U_{\text{OutputVoltage B}} = -18 \text{ V} - \frac{(-18 \text{ V} - (-2 \text{ V})) * \sin 15 * n}{4 \text{ mm}}$$

Table 9-51: Measuring range check - Double Cone 2 measurement

n [mm]	U _{OutputVoltage} [V], (Sensor A)	U _{OutputVoltage} [V], (Sensor B)	Online Display [mm] ¹
0	-2.00	-18.00	
1	-3.04	-16.96	
2	-4.07	-15.93	-4
3	-5.11	-14.89	-3
4	-6.14	-13.86	-2
5	-7.18	-12.82	-1
6	-8.21	-11.79	0
7	-9.25	-10.75	1
8	-10.28	-9.72	2
9	-11.32	-8.68	3
10	-12.35	-7.65	4
11	-13.39	-6.61	5
12	-14.42	-5.58	6
13	-15.46	-4.54	7
14	-16.49	-3.51	8
15	-17.53	-2.47	

¹ Without zero point correction

1. Measure the converter output voltage of both measuring chains (sensor A and sensor B) on terminals OUT and GND. Use a DC voltmeter.
2. Set the calculated converter output voltages as shown in [Table 9-51](#) when passing through the measuring range.
3. Compare the displayed value with the values shown in [Table 9-51](#). For example, sensor A: -5.11 V and sensor B: -14.89 V corresponds to -3 mm.

9.2.6 Combined channels – shaft position Tandem

In this mode both channels of the A6500-UM Universal Measurement Card are combined for measure and calculate the relative shaft position, distance, expansion, and so on in the unit "mm" or "mil" ("mm" is used for the following example).

The Tandem measurement measures the axial shaft movement with two sensors that are arranged at a measuring collar. This measuring arrangement permits an overall measuring range that corresponds to the sum of the single-channel measuring ranges minus approximately 10%.

Both measuring chains must be of same type and must have the same channel configuration.

This description is also valid for **Tandem II**, with the difference that the intersection point must not be configured. The intersection point related parameters are disabled. Also ensure that there is no measuring range overlap when configuring **Tandem II**. See [Switching from Tandem to Tandem II](#). An overlapping measuring range causes a measuring value offset at the intersection point.

Mechanical prerequisites

- Sensor holder with dovetail guide for common movement of both sensors and single movement of one sensor.
- Measuring collar with sufficient height for the selected eddy current sensors. See sensor operation manual for requirements.
- The sensors must be vertical to the measurement collar.
- Sensor A measures the negative or lower part of the measuring range and sensor B the positive or upper part.

Measuring range definition

As the maximum measuring range consists of the two individual measuring ranges an intersection point is required. At this point the measurement changes from one channel (sensor) to the other one. The intersection point is detected automatically by the Universal Measurement Card when passing through the measuring range. Both curves of sensor A and sensor B must overlap for the detecting of this point (see [Figure 9-39](#)). The required overlapping causes a common measuring range which is reduced by approximately 10% compared to the sum of the single measuring ranges.⁶

⁶ Ensure that there is no overlap at the intersection point when configuring a **Tandem II** measurement.

Figure 9-39: Sensor arrangement Tandem and measurement example

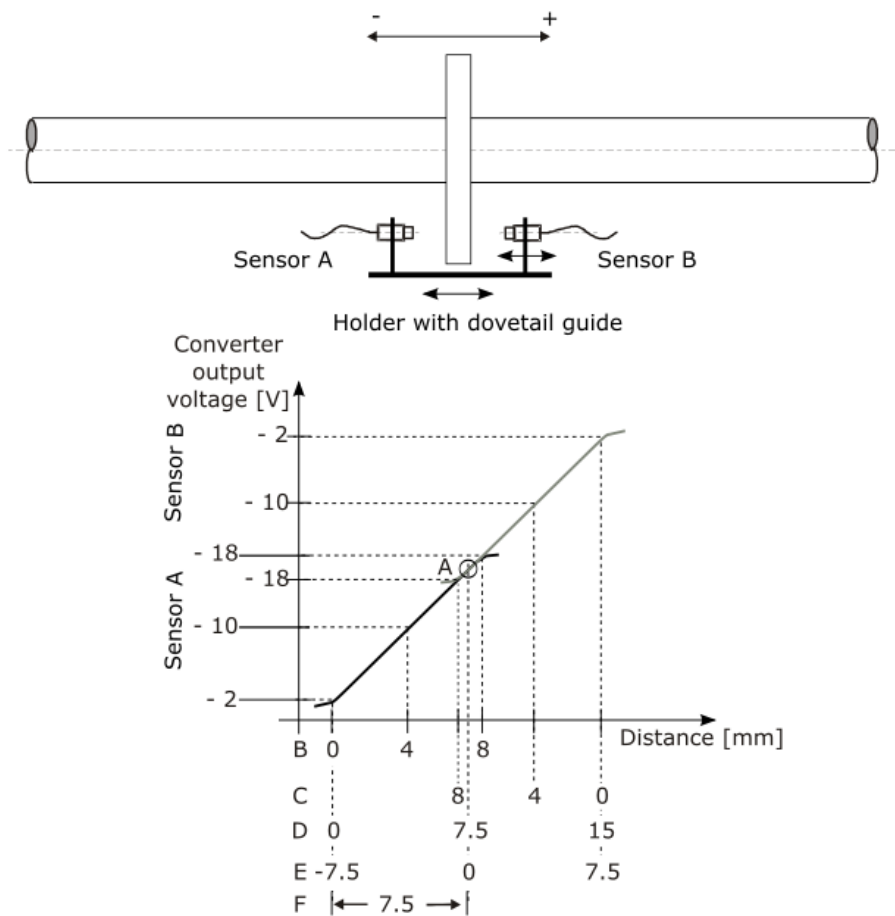

- A. Intersection point
- B. Measuring range PR 6426 0 to 8 mm (Sensor A)
- C. Measuring range PR 6426 0 to 8 mm (Sensor B)
- D. Maximum range with single measuring range overlapping
- E. Measuring range used
- F. S_{zero} for the example measuring range (zero point definition)

The zero point of the measuring range is specified with parameter **Shift** on configuration page **Measurement**. If the measuring range has the form 0 to X, 0 mm is entered for the shift. For a measuring range of -X to 0 to +X the distance from the measuring range beginning to the center point of the measuring range must be entered.

Sensor adjustment

Note

The position of the shaft must be known when adjusting the sensor.

Emerson recommends eddy current measuring chains consisting of the listed sensors and converters (see [Table 9-52](#)).

Table 9-52: Recommended sensors and converters

Sensors and converters
Sensors
EZ 105x-xx-xx-xxx
EZ 108x-xx-xx-xxx
PR 6422/xxx-xxx
PR 6423/xxx-xxx
PR 6424/xxx-xxx
PR 6425/xxx-xxx
PR 6426/xxx-xxx
Converters
EZ 1000
CON 011
CON 021
CON 031
CON 041

Note

If the sensors are mounted close together, the measuring chains can influence each other. Emerson recommends the use of one detuned measuring chain for the Tandem measurement. See respective converter operation manual.

Used values for example:

- Sensor measuring range of PR 6426: 8 mm
- Converter output voltage range: -2 to -18 V
- S_{zero} : 7.5 mm
- Maximum sensor displacement: 15.00 mm.
- Required measuring range: 15 mm in the range of -7.5 mm to +7.5 mm.

1. Define the needed measuring range.

[Figure 9-40](#) shows an example measuring range of -7.5 mm to +7.5 mm within the maximum measuring range of 15 mm.

Figure 9-40: Measuring range diagram with example values

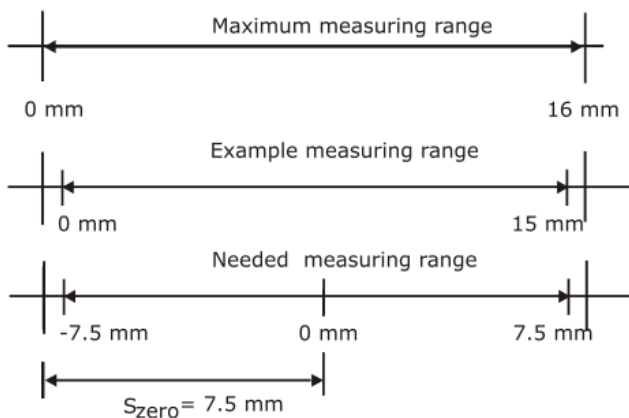

S_{zero} : Distance between beginning of measuring range and zero position of the range or other defined shaft position.

The zero point is specified with parameter **Shift** on configuration page **Measurement**.

2. Switch on the power supply of the system rack in which the Universal Measurement Card is installed.
3. Measure the output voltage of the measuring chains with a DC voltmeter on the terminals OUT and \perp (GND) of the converter.
4. Move the common sensor holder relative to the measuring collar so that the output voltage of the measuring chain with fixed sensor corresponds as precisely as possible to the value of the upper sensor voltage, minus the overlap⁷ (for example: $-18\text{ V} - (-1\text{ V}) = -17\text{ V}$) and fix the common holder in this position. Ensure that the adjusted distance does not change during fixing the sensor.
5. Move the adjustable sensor on the holder so that the output voltage of the associated converter likewise corresponds as precisely as possible to the value of the upper sensor voltage, minus the overlap⁷ for example $-18\text{ V} - (-1\text{ V}) = -17\text{ V}$). Fix the sensors in this position on the holder. Ensure that the adjusted distance does not change during fixing the sensor.

See operation manual of the sensor used for further installation details.

Figure 9-41 shows a voltage output curve after incorrect sensor adjustment. The intersection point can not be detected as there is no overlapping⁷ of the converter output voltage curves.

⁷ Ensure that there is no overlap at the intersection point when configuring a **Tandem II** measurement.

Figure 9-41: Sensor adjustment error

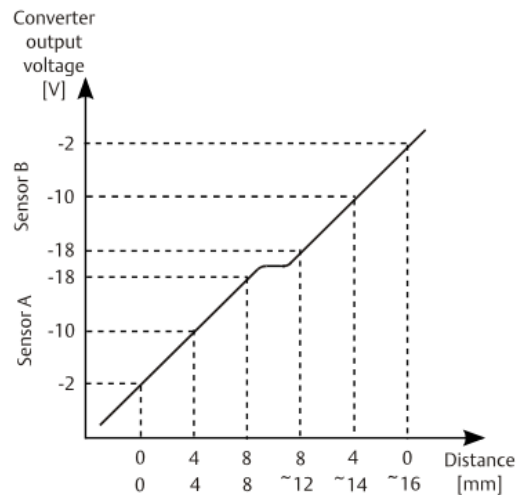

The currently used intersection point is indicated on the **Details** page of the online view (see [Figure 9-42](#)).

Figure 9-42: Details - Intersection point

Values			
Speed	2 989 RPM	Sensor 1 DC	-9.99 V
Rotation freq.	49.8 Hz	Sensor 2 DC	-21.31 V
Intersection point	1.87 mm		

Card configuration

Creating the configuration:

Note

See [General configuration procedure](#) for description of the general configuration process.

The intersection point, where the curve switches from one sensor to the other sensor, is determined with the intersection point automatic. For this, the entire measuring range must be passed from the lower value to the higher value (by moving the common holder). The monitor identifies the value, where both channels have the same maximum as the intersection point. We recommend to deactivate the Intersection point auto mode after commissioning.

The measured position value can be supervised on limit violation and output through:

- Current outputs.
- Modbus communication of the A6500-CC Com Card.
- OPC UA communication of the A6500-CC Com Card.

Digital alarm outputs can be used for indication of limit violation.

Select the appropriate application from the "New Configuration" window.

1. Click **Calculation based on two channels** to open the application list.
2. Select **Tandem/Cone**.
3. Enter the parameters.

See [Table 9-53](#) for an example configuration of a shaft position measurement with two eddy current measuring chains consisting of a PR 6426/xxx-xxx and a CON 011 with a converter output voltage range of -2 V to -18 V. Only significant parameters are listed.

Table 9-53: Shaft position, Tandem measurement – example configuration

Configuration page	Parameter	Value
Input 1	Sensor	PR 6426
	Converter	CON 011 -2/-18V
Input 2	Sensor	PR 6426
	Converter	CON 011 -2/-18V
Linearization 1	Line 1 [V] / [mm]	-18 / 8
	Line 2 [V] / [mm]	-2 / 0
Linearization 2	Line 1 [V] / [mm]	-18 / 8
	Line 2 [V] / [mm]	-2 / 0
Measurement	Evaluation	Tandem
	Begin [mm]	-7.5
	End [mm]	7.5
	Shift [mm]	7.5
	Intersection point auto mode	Box checked (uncheck after commissioning)
	Tacho	Time
Current output 1	Current output	4 - 20 mA
	Current suppression ¹	Box checked
Current output 2	Current output	4 - 20 mA
	Current suppression ¹	Box checked
Alarm limits 1	Enabled	Box checked
	Upper danger alarm [mm]	6.0
	Upper alert alarm [mm]	4.5
	Lower alert alarm [mm]	-4.5
	Lower danger alarm [mm]	-6.0
	Alarm hysteresis [mm]	0.1
	Limit suppression	Box checked

Table 9-53: Shaft position, Tandem measurement – example configuration
(continued)

Configuration page	Parameter	Value
Alarm limits 2	Enabled	Box not checked

¹ Optional parameter

- Click **Send & close** to send the configuration to the card.

Zero point correction

If the converter output voltage cannot be set precisely on the zero point voltage or a another defined voltage use the parameter **Shift** on configuration page **Measurement** for correction.

- Complete following formula with S_{zero} and measured value shown by the online display.

$$S_{zero\ corrected} = S_{zero} + Value_{displayed}$$

Example with $Value_{Display}$ is 0.03 mm and S_{zero} is 7.5 mm (see parameter: Shift):

$$S_{zero\ corrected} = 7.5\text{ mm} + 0.03\text{ mm} = 7.53\text{ mm}$$

- Enter the new calculated value for the parameter **Shift**.
- Send the configuration to the card.
- The online view shows 0.00 mm.

Note

The current output will be adjusted accordingly.

Measuring range check

Check the measuring range after completing sensor adjustment and configuration. This can be done by shifting the measuring object (if possible) or the common sensor holder through the measuring range. For reference, the converter output voltage of both measuring chains related to the position value can be calculated with the following formulas (see Table 9-54 for example values).

Sensor A

$$U_{OutputVoltage\ A} = U_{SensorStart\ A} - n_A * Sensitivity$$

Sensor B

$$U_{OutputVoltage\ B} = U_{SensorStart\ B} - n_B * Sensitivity$$

n_A : Position sensor A

n_B : Position sensor B

Example:

- Sensitivity PR 6426: 2 V/mm
- Converter output voltage range: -2 V ($U_{\text{SensorStart}}$) to -18 V ($U_{\text{SensorEnd}}$)
- Sensor measuring range: 0 to 8 mm $\rightarrow n_A = n_B = 0$ to 8 mm
- Configured measuring range: -7.5 to +7.5 mm

$$U_{\text{OutputVoltage A}} = -2 \text{ V} - n_A * 2 \frac{\text{V}}{\text{mm}}$$

$$U_{\text{OutputVoltage B}} = -2 \text{ V} - n_B * 2 \frac{\text{V}}{\text{mm}}$$

Table 9-54: Measuring range check - Tandem measurement

n_A [mm]	n_B [mm]	$U_{\text{OutputVoltage A}}$ [V], (Sensor A)	$U_{\text{OutputVoltage B}}$ [V], (Sensor B)	Online Display [mm] ¹
0		-2.00	x	-7.5
1		-4.00	x	-6.5
2		-6.00	x	-5.5
3		-8.00	x	-4.5
4		-10.00	x	-3.5
5		-12.00	x	-2.5
6		-14.00	x	-1.5
7	8 ²	-16.00	-18.00 ²	-0.5
7.5	7.5	-17.00	-17.00	0
8 ²	7	-18.00 ²	-16.00	0.5
	6	x	-14.00	1.5
	5	x	-12.00	2.5
	4	x	-10.00	3.5
	3	x	-8.00	4.5
	2	x	-6.00	5.5
	1	x	-4.00	6.5
	0	x	-2.00	7.5

¹ Without zero point correction

² Measuring range overlapping, not with **Tandem II**

x: Sensor is not in the working range (example: -2 to -18 V)

1. Measure the converter output voltage of both measuring chains (sensor A and sensor B) on terminals OUT and GND. Use a DC voltmeter.
2. Set the calculated converter output voltages as shown in [Table 9-54](#) when passing through the measuring range.

3. Compare the displayed value with the values shown in [Table 9-54](#). For example, sensor A: -8.00 V and sensor B: x corresponds to -4.5 mm.

Switching from Tandem to Tandem II

Make the following changes to the configuration when switching the evaluation from **Tandem** to **Tandem II** without changing the adjustment of the sensors.

1. Adjust the linearization of the sensors to remove the measuring range overlapping.

Note

Ensure that there is no measuring range overlapping as the overlapping which is necessary for the **Tandem** evaluation causes measuring errors at the **Tandem II** evaluation.

- a. Select **Linearization 1**.

The linearization values of the sensor connected to input 1 are listed. The example in [Figure 9-43](#) shows a two point linearization of an eddy current measuring chain with an output voltage range of -4 V to -20 V scaled on a distance range of 0 to 24 mm.

Figure 9-43: Linearization 1 – Tandem



[Table 9-55](#) lists distances and voltages around the intersection point corresponding to the linearization in [Figure 9-43](#). The intersection point is at -17.40 V for both input channels. The voltage range from -18.07 V to -20.08 V, corresponding to 21 mm to 24 mm, is the overlapping range of both sensors. This overlapping range must be removed if switching to **Tandem II**.

Table 9-55: Tandem measurement – Voltages around the intersection point

Distance measuring chain 1 [mm]	Distance measuring chain 2 [mm]	$U_{\text{Input 1}}$ [V]	$U_{\text{Input 2}}$ [V]	Measuring range [mm]
0		-4.00		-20
1		-4.67		-19
2		-5.34		-18
...	

Table 9-55: Tandem measurement – Voltages around the intersection point (continued)

Distance measuring chain 1 [mm]	Distance measuring chain 2 [mm]	U _{Input 1} [V]	U _{Input 2} [V]	Measuring range [mm]
14		-13.38		-6
15		-14.05		-5
16	24	-14.72	-20,08	-4
17	23	-15.39	-19,41	-3
18	22	-16.06	-18,74	-3
19	21	-16.73	-18,07	-1
20 ¹	20 ¹	-17.40 ¹	-17.40 ¹	0 ¹
21	19	-18,07	-16.73	1
22	18	-18,74	-16.06	2
23	17	-19,41	-15.39	3
24	16	-20,08	-14.72	4
	15		-14.05	5
	14		-13.38	6

	2		-5.34	18
	1		-4.67	19
	0		-4.00	20

¹ Intersection point

- b. Change the linearization table. Enter the voltage and distance of the intersection point for the first linearization point. See example in [Figure 9-44](#). If the table contains more points adjust them accordingly.

Figure 9-44: Linearization 1 – Tandem II

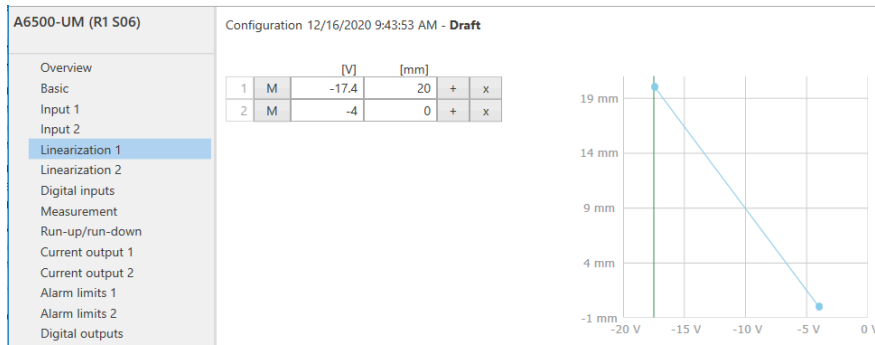

- c. Repeat this change for **Linearization 2**.
2. Change **Measurement** → **Evaluation** to **Tandem II**
3. Send the changes to the A6500-UM.

9.2.7 Combined channels – shaft position Min/Max

In this mode the measured position values of both channels of the A6500-UM Universal Measurement Card are compared.

- Value Max: the greater one of the two values will be output
- Value Min: the lower one of the two values will be output

Both measuring chains must be of same type and must have the same channel configuration. Unit "mm" or "mil" ("mm" is used for the following example).

Figure 9-45 shows a sensor arrangement example with an eddy current sensor measuring the shaft position at a shaft collar.

Figure 9-45: Sensor arrangement Min/Max and measurement example

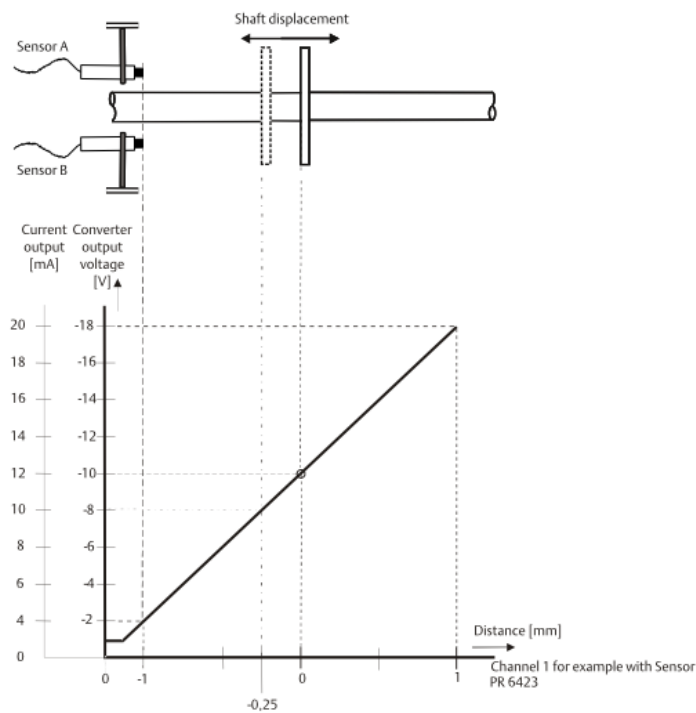

Sensor adjustment

Note

The position of the shaft must be known when adjusting the sensor.

Emerson recommends eddy current measuring chains consisting of the listed sensors and converters (see Table 9-56).

Table 9-56: Recommended sensors and converters

Sensors and converters
Sensors
EZ 105x-xx-xx-xxx
EZ 108x-xx-xx-xxx
PR 6422/xxx-xxx
PR 6423/xxx-xxx
PR 6424/xxx-xxx
PR 6425/xxx-xxx
PR 6426/xxx-xxx
Converters
EZ 1000
CON 011
CON 021
CON 031
CON 041

The sensor must be set to the center of its static measuring range or another defined position by measuring the converter output voltage. This position must be the same for both channels.

1. Define the needed measuring range.

Figure 9-46 shows a needed unsymmetrical measuring range of $-x/4$ mm to $+x/1.33$ mm within the sensor measuring range of 0 to x mm.

Figure 9-46: Example position measuring

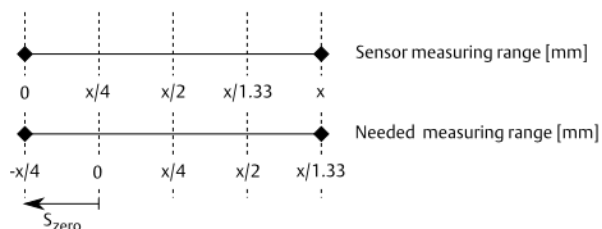

s_{zero} : Distance between beginning of measuring range and zero position of the range or other defined shaft position.

2. Calculate the sensor adjustment voltage depending on the needed measuring range.
For adjusting the distance between measurement object (shaft collar) and sensor at zero position of the shaft or other defined position the related converter output voltage must be defined.

$$U_{\text{zero}} = \frac{(U_{\text{SensorEnd}} - U_{\text{SensorStart}}) * S_{\text{zero}}}{S_{\text{MeasuringRange}}} + U_{\text{SensorStart}}$$

Example with sensor measuring range of 0 to 2 mm, converter output voltage range of -2 V to -18 V DC and needed measuring range of -0.5 mm to +1.5 mm:

$$U_{\text{zero}} = \frac{(-18 \text{ V} - (-2 \text{ V})) * 0.5 \text{ mm}}{2 \text{ mm}} + (-2 \text{ V}) = -6 \text{ V}$$

3. Switch on the power supply of the System Rack in which the Universal Measurement Card is installed.
4. Measure the output voltage of the measuring chain with a DC voltmeter on the terminals OUT and ⊥ (GND) of the converter.
5. Adjust the distance between sensor and measurement object so that the connected DC voltmeter displays the calculated adjustment voltage (U_{zero}).
6. Fix the sensor in this position. Ensure that the adjusted distance does not change during fixing the sensor.

Repeat steps 3 to 6 for the other channel.

See operation manual of the sensor used for further installation details.

Card configuration

Note

See [General configuration procedure](#) for description of the general configuration process.

The measured position value can be supervised on limit violation and output through:

- Current outputs.
- Modbus communication of the A6500-CC Com Card.
- OPC UA communication of the A6500-CC Com Card.

Digital alarm outputs can be used for indication of limit violation.

Select the appropriate application from the "New Configuration" window.

1. Click **Calculation based on two channels** to open the application list.
2. Select **Tandem/Cone**.
3. Enter the parameters.

See [Table 9-57](#) for an example configuration of a shaft position Min/Max measurement with two eddy current measuring chain consisting of a PR 6423/xxx-xxx and a CON 011 with a converter output voltage range of -2 V to -18 V. Only significant parameters are listed.

Table 9-57: Shaft position Min/Max – example configuration

Configuration page	Parameter	Value
Input 1	Sensor	PR 6423
	Converter	CON 011 -2/-18V

Table 9-57: Shaft position Min/Max – example configuration (continued)

Configuration page	Parameter	Value
Input 2	Sensor	PR 6423
	Converter	CON 011 -2/-18V
Linearization 1	Line 1 [V] / [mm]	-18 / 1.5
	Line 2 [V] / [mm]	-2 / -0.5
Linearization 2	Line 1 [V] / [mm]	-18 / 1.5
	Line 2 [V] / [mm]	-2 / -0.5
Measurement	Evaluation	Min/Max
	Begin [mm]	-0.5
	End [mm]	1.5
	Shift [mm]	0
	Tacho	Time
Current output 1	Evaluation	Min
	Current output	4 - 20 mA
	Current suppression ¹	Box checked
Current output 2	Evaluation	Max
	Current output	4 -20 mA
	Current suppression ¹	Box checked
Alarm limits 1	Enabled	Box checked
	Evaluation	Min
	Upper danger alarm [mm]	1.3
	Upper alert alarm [mm]	1.1
	Lower alert alarm [mm]	-0.1
	Lower danger alarm [mm]	-0.3
	Alarm hysteresis [mm]	0.1
	Limit suppression	Box checked
Alarm limits 2	Enabled	Box checked
	Evaluation	Max
	Upper danger alarm [mm]	1.3
	Upper alert alarm [mm]	1.1
	Lower alert alarm [mm]	-0.1
	Lower danger alarm [mm]	-0.3
	Alarm hysteresis [mm]	0.1
	Limit suppression	Box checked

1 Optional parameter

4. Click **Send & close** to send the configuration to the card.

9.2.8 Combined channels – absolute shaft expansion

In this mode both channels of the A6500-UM Universal Measurement Card are combined for measuring and calculating the absolute shaft expansion, in the unit "mm" or "mil" ("mm" is used for the following example). The absolute shaft expansion is the absolute housing expansion subtracted from the relative shaft expansion.

Absolute shaft expansion = Relative shaft expansion - Absolute housing expansion

Figure 9-47 shows the setup of the absolute shaft expansion measurement. An A6500-LC converter is required for the connection of linear displacement transducers to the Universal Measurement Card.

Figure 9-47: Sensor arrangement example – absolute shaft expansion measurement

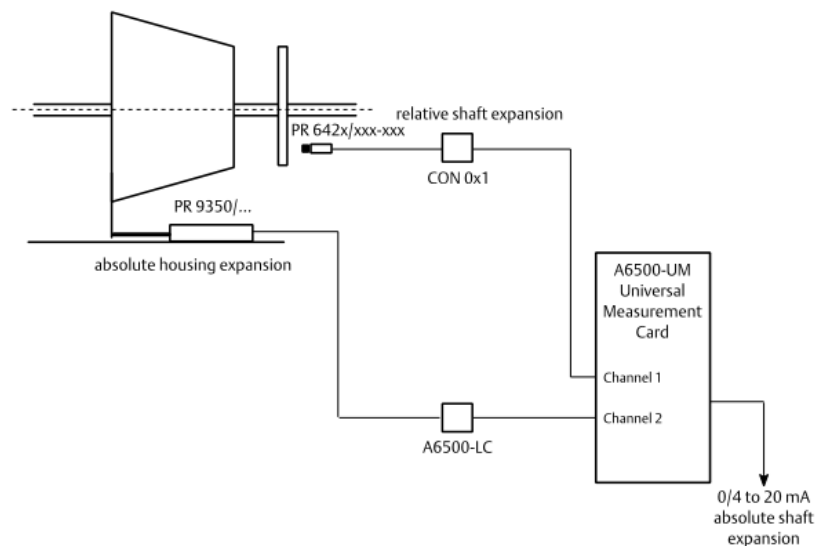

Sensor adjustment

For adjustment of eddy current sensors see chapter [Sensor adjustment](#). Follow the commissioning instructions in the A6500-LC operating manual (MHM-97878) for the adjustment of linear displacement transducers.

Card configuration

Note

See [General configuration procedure](#) for description of the general configuration process.

The measured position value can be supervised on limit violation and output through:

- Current outputs.
- Modbus communication of the A6500-CC Com Card.

- OPC UA communication of the A6500-CC Com Card.

Digital alarm outputs can be used for indication of limit violation.

Select the appropriate application from the "New Configuration" window.

1. Click **Calculation based on two channels** to open the application list.
2. Select **Absolute shaft expansion**.
3. Enter the parameters.

See [Table 9-58](#) for an example configuration of an absolute shaft expansion measurement with an eddy current measuring chain consisting of a PR 6426/xxx-xxx and a CON 011 with a converter output voltage range of -2 V to -18 V and a PR 9350/02 linear displacement transducer with an A6500-LC with an output voltage range of 2 V to 18 V. Only significant parameters are listed.

Table 9-58: Absolute shaft expansion – example configuration

Configuration page	Parameter	Value
Input 1	Sensor	PR 6426
	Converter	CON 011 -2/-18V
Input 2	Sensor	PR 9350/02
	Converter	A6500-LC 2/18V
Linearization 1	Line 1 [V] / [mm]	-18 / 6
	Line 2 [V] / [mm]	-2 / -2
Linearization 2	Line 1 [V] / [mm]	12.7 / 10
	Line 2 [V] / [mm]	7.3 / -10
Measurement	Evaluation	Absolute difference
	Begin [mm]	-6.0
	End [mm]	6.0
	Shift [mm]	0
	Tacho	Time
Current output 1	Current output	4 - 20 mA
	Current suppression ¹	Box checked
Current output 2	Current output	4 - 20 mA
	Current suppression ¹	Box checked
Alarm limits 1	Enabled	Box checked
	Upper danger alarm [mm]	5.0
	Upper alert alarm [mm]	4.0
	Lower alert alarm [mm]	-4.0
	Lower danger alarm [mm]	-5.0
	Alarm hysteresis [mm]	0.1

Table 9-58: Absolute shaft expansion – example configuration (continued)

Configuration page	Parameter	Value
	Limit suppression	Box checked
Alarm limits 2	Enabled	Box not checked

¹ Optional parameter

- Click **Send & close** to send the configuration to the card.

9.2.9 Combined channels – absolute shaft vibration

In this mode both channels of the A6500-UM Universal Measurement Card are combined to measure and calculate the absolute shaft vibration, unit " μm " or "mil" (" μm " is used for the following example). Signal evaluation in **Displacement 0-P**, **Displacement P-P**, or **Displacement RMS**. The absolute shaft vibration is the absolute bearing vibration subtracted from the relative shaft vibration.

Absolute shaft vibration = Relative shaft vibration - Absolute bearing vibration.

Use eddy current measuring chains to measure the relative shaft vibration and seismic or piezoelectric sensors to measure the absolute bearing vibration.

Note

Ensure that both sensors, the eddy current sensor for the relative shaft vibration and the sensor for the absolute bearing vibration, are mounted in the same measurement direction at the same measurement location. Emerson recommends a common holder for both sensors.

Figure 9-48 shows the setup of the absolute shaft vibration measurement.

Figure 9-48: Sensor arrangement example – absolute shaft vibration measurement

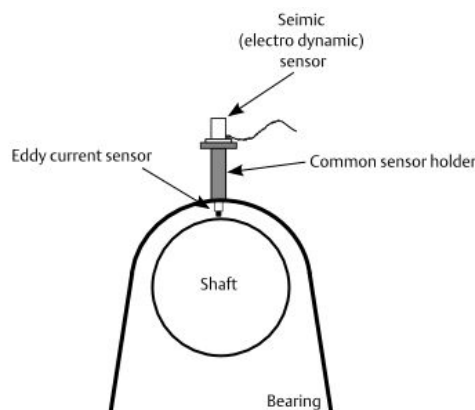

Sensor adjustment

For adjustment of eddy current sensors for shaft vibration measurement see chapter [Sensor adjustment](#). For installation details of the used bearing vibration sensor see the respective sensor manual.

1. Connect the bearing vibration sensor to channel 1.
2. Connect the eddy current sensor to channel 2.

Card configuration

Note

See [General configuration procedure](#) for description of the general configuration process.

The measured absolute shaft vibration value can be supervised on limit violation and output through:

- Current outputs.
- Modbus communication of the A6500-CC Com Card.
- OPC UA communication of the A6500-CC Com Card.

Digital alarm outputs can be used for indication of limit violation.

Select the appropriate application from the "New Configuration" window.

1. Click **Calculation based on two channels** to open the application list.
2. Select **Absolute shaft vibration**.
3. Enter the parameters.

See [Table 9-59](#) for an example configuration of an absolute shaft vibration measurement with a PR 9268/20x-xxx seismic bearing vibration sensor connected to channel 1 and an eddy current measuring chain consisting of a PR 6423/xxx-xxx and a CON 011 with a converter output voltage range of -2 V to -18 V connected to channel 2 .

Table 9-59: Absolute shaft vibration – parameter of example configuration

Configuration page	Parameter	Value
Input 1	Sensor	PR 9268/20x-xxx
	Mounting angle	0°
	Connection type	2-wire
Input 2	Sensor	PR 6423
	Converter	CON 011 -2/-18 V
Measurement	Evaluation	Displacement 0-P
	Measuring range [µm]	100
	Tacho	Key 1
	Nominal speed	3000
	Sensor 1 damping	0.56
	Sensor 1 natural frequency	4.5
Current output 1	Current output	4 - 20 mA
	Current suppression ¹	Box checked
Current output 2	Current output	4 - 20 mA

Table 9-59: Absolute shaft vibration – parameter of example configuration
(continued)

Configuration page	Parameter	Value
	Current suppression ¹	Box checked
Alarm limits 1	Enabled	Box checked
	Danger alarm [μm]	80
	Alert alarm [μm]	60
	Alarm hysteresis [μm]	5
	Limit suppression	Box checked
Alarm limits 2	Enabled	Box not checked

¹ Optional parameter

- Click **Send & close** to send the configuration to the card.

9.2.10 Combined channels – cylinder pressure

In this mode, both channels of the A6500-UM Universal Measurement Card are combined to measure and calculate pressure and forces at reciprocating compressors. The static pressure sensor connected to **Input 1** is considered to measure at the crank side of the cylinder and the static pressure sensor connected to **Input 2** is considered to measure at the head side of the cylinder. See [Table 9-60](#) for signal evaluation details. Each evaluation requires a key-signal.

Table 9-60: Signal evaluation

Sensor type	Signal evaluation	Unit	Description
Static pressure sensor	Discharge pressure chamber 1/ chamber 2	kPa or psi(g)	Pressure inside the Cylinder at top dead center position.
	Suction pressure chamber 1/ chamber 2		Pressure inside the cylinder at bottom dead center position.
	Maximum/ minimum pressure chamber 1/ chamber 2		Minimum/maximum pressure inside the cylinder over one cycle.
	Compression ratio chamber 1/ chamber 2		Ratio between Discharge pressure and Suction pressure .

Table 9-60: Signal evaluation (continued)

Sensor type	Signal evaluation	Unit	Description
	Peak rod compression	kN	Peak combined rod load in compressing direction.
	Peak rod tension		Peak combined rod load in tension direction.
	Degree of rod reversal	°	Smallest distance between the points of zero force (combined rod load) represents the degrees of rod reversal.

The static pressure sensors are typically installed into pressure indicator ports of the reciprocating compressor to be supervised.

Sensor adjustment

See respective sensor manual for adjustment instructions.

Card configuration

Note

See [General configuration procedure](#) for a description of the general configuration process.

The measured value can be supervised on limit violation and output through:

- Current outputs
- Modbus communication
- OPC UA communication

Digital alarm outputs can be used for indication of limit violation.

Procedure

1. Select the application in the **New Configuration** dialog.
 - a) Click **Calculation based on two channels** to open the application list.
 - b) Select **Cylinder pressure** for the appropriate channel.
 - c) Click **Create Configuration**.

2. Enter parameters.

See [Table 9-61](#) for an example configuration of a cylinder pressure measurement with calculation based on two channels with static pressure sensors installed close to the suction valve. The compressor is a double chamber compressor. Only the significant parameters for the measurements are listed. The measuring range is defined by the selected sensors.

Table 9-61: Cylinder pressure – example configuration

Configuration page	Parameter	Value
Input 1	Sensor	Bently 165855-x1
Measurement 1	Evaluation	Suction pressure chamber 1
	Input 1	Crank side (chamber 1)
	Input 2	Head side (chamber 2)
	Measuring range [kPa]	600
	Piston angle [°]	45
	Tacho	Key 1
	Nominal speed [rpm]	270
	Stroke length [mm]	290
	Connection rod length [mm]	770
	Piston weight [kg]	145
	Crosshead weight [kg]	195
	Piston diameter [mm]	302
	Piston rod diameter [mm]	95
	Tail rod diameter [mm]	95
	Ambient pressure [kPa]	101.325
Rod load	At crosshead pin	
Current output 1	Current output	4 -20 mA
	Current suppression ¹	Box checked

¹ Optional parameter

3. Click **Send & close** to send the configuration to the card.

9.2.11 Combined channels – housing expansion Add/Sub

In this mode both channels of the A6500-UM Universal Measurement Card are combined for measuring and calculation distance measurements as, for example, absolute housing expansion, valve position, and so on. The measurement value is formed by adding or subtracting the single-channel values. Unit "mm" or "mil" ("mm" is used for the following example).

Note

Connection of PR 9350/xx linear displacement transducers or similar sensors to the A6500-UM requires always the A6500-LC converter.

Figure 9-49 shows an example with two PR 9350/02 linear displacement transducers measuring the housing expansion whereat channel 2 is subtracted from channel 1.

Figure 9-49: Sensor arrangement example – combined channel housing expansion Add/Sub

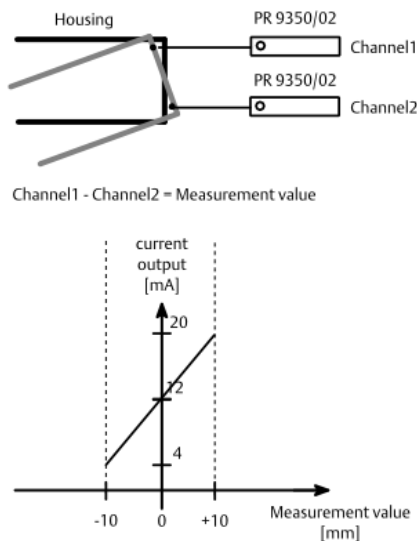

Sensor adjustment

Note

The position of the measuring object, for example, of the housing must be known when adjusting the sensor.

Connection of a PR 9350/xx linear displacement transducer to the A6500-UM always requires the A6500-LC converter.

Follow the commissioning instructions in the A6500-LC operating manual (MHM-97878).

See operation manual of the sensor used for further installation details.

Card configuration

Note

See [General configuration procedure](#) for description of the general configuration process.

The calculated expansion value can be supervised on limit violation and output through:

- Current outputs.
- Modbus communication of the A6500-CC Com Card.
- OPC UA communication of the A6500-CC Com Card.

Digital alarm outputs can be used for indication of limit violation.

Select the appropriate application from the "New Configuration" window.

1. Click "Calculation based on two channels" to open the application list.
2. Select "Tandem/Cone".
3. Enter the parameters.

See [Table 9-62](#) for an example configuration of a housing expansion measurement with two PR 9350/02 linear displacement transducers. The measurement value is formed by subtraction of value channel 2 from value channel 1.

Table 9-62: Housing expansion Add/Sub – example configuration

Configuration page	Parameter	Value
Input 1	Sensor	PR 9350/02
	Converter	A6500-LC 2/18V
Input 2	Sensor	PR 9350/02
	Converter	A6500-LC 2/18V
Linearization 1	Line 1 [V]/[mm]	2 / 25
	Line 2 [V]/[mm]	18 / -25
Linearization 2	Line 1 [V]/[mm]	2 / 25
	Line 2 [V]/[mm]	18 / -25
Measurement	Evaluation	Sub
	Begin [mm]	-10
	End [mm]	10
	Shift [mm]	0
	Tacho	Key 1
	Nominal speed	3000
Current output 1	Current output	4 - 20 mA
	Current suppression ¹	Box checked
Current output 2	Current output	4 - 20 mA
	Current suppression ¹	Box checked
Alarm limits 1	Enabled	Box checked
	Upper danger alarm [mm]	7
	Upper alert alarm [mm]	5
	Lower alert alarm [mm]	-5
	Lower danger alarm [mm]	-7
	Alarm hysteresis [mm]	0.5
	Limit suppression	Box checked
Alarm limits 2	Enabled	Box not checked

¹ Optional parameter

- Click "Send & close" to send the configuration to the card.

9.2.12 Combined channels – Rotational direction

In this mode both channels of the A6500-UM Universal Measurement Card are combined for a two channel speed measurement and detection of the rotational direction.

For mechanical requirements, sensor adjustment, and trigger level definition see [Single-channel – speed measurement](#). Use these instructions for both channels.

Radial arrangement of the sensors

For rotational direction detection arrange the sensor so at the trigger wheel, that there is a phase shift between the signals of channel 1 and channel 2. The optimum phase shift is 180°. The pulse edge of the input signal of channel 2 must be as precise as possible in the middle of the pulse of the input signal of channel 1. Emerson recommends a sensor holder with the possibility to adjust one sensor radially to correct the phase shift. Use the following formula to calculate the mounting position of the sensor of channel 2 depending on the mounting position of the sensor of channel 1.

$$\text{Sensor position channel 2} = \text{Sensor position channel 1} + (n + 0.5) * P$$

n: number of teeth between the sensors

with

$$P = \frac{2\pi R}{n}$$

r: trigger wheel radius plus distance to sensor

n: number of teeth of the trigger wheel

[Figure 9-50](#) shows the arrangement of both sensors.

Figure 9-50: Rotational direction detection – sensor arrangement

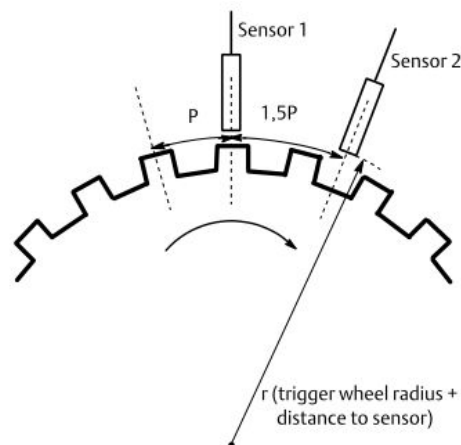

Card configuration

Note

See [General configuration procedure](#) for description of the general configuration process.

The detected rotational direction can be supervised and output through:

- Modbus communication of the A6500-CC Com Card.
- OPC UA communication of the A6500-CC Com Card.

Digital alarm outputs can be used for indication of the rotational direction.

Select the appropriate application from the **New Configuration** window.

1. Click **Calculation based on two channels** to open the application list.
2. Select **Speed (redundant)**.
3. Enter the parameters.

See [Table 9-63](#) for an example configuration of a detection of the rotational direction with two eddy current measuring chains consisting of a PR 6423/xxx-xxx and a CON 011 with a converter output voltage range of -2 V to -18 V. Only significant parameters are listed.

Table 9-63: Detection of rotational direction – example configuration

Configuration page	Parameter	Value
Input 1	Sensor	PR 6423
	Converter	CON 011 -2/-18V
Input 2	Sensor	PR 6423
	Converter	CON 011 -2/-18V
Measurement 1 and Measurement 2	Channel off	Box not checked
	Measure mode	n times per rotation
	Glitch suppression	Box checked
	Maximum speed [RPM]	3500
	Symmetry [%]	50
	Input mode	Dynamic (fast)
	Number of teeth	32
	Gap threshold limit [V] (Optional parameter)	-2 V
	Preferred rotation direction ¹	normal
Reset rotation direction ¹	low	
Current output 1 and current output 2	Evaluation	Speed
	Current output	4 - 20 mA
	Current suppression ¹	Box checked
Digital outputs	Out 1 (Ch 1 - Speed / >= Limit)	3000

Table 9-63: Detection of rotational direction – example configuration
(continued)

Configuration page	Parameter	Value
	Out 2 (Rotational - Ch 1/2 / Normal)	---
	Out 4 (Ch 2 - Speed / >= Limit)	---
	Out 5 (Ch 1 - Standstill / Normal)	---
	Limit suppression	Box checked

¹ *Optional parameter*

4. Click **Send & close** to send the configuration to the card.

10 Functional check and maintenance

10.1 Functional check

⚠ CAUTION

Any work at the system may impair machine protection

10.1.1 Card check procedures

Check the card and configuration by simulating a sensor signal with a function generator. See operation manual of the used function generator for signal connection and adjustment details. [Figure 10-1](#) shows the connection of a function generator to channel 1 of a card slot. Use this setup to simulate signals of:

- Eddy current measuring chains
- Piezoelectric sensors in 4-wire mode
- Seismic sensors in 4-wire mode
- Hall-effect sensors
- A6500-LC

Figure 10-1: Function generator connection example

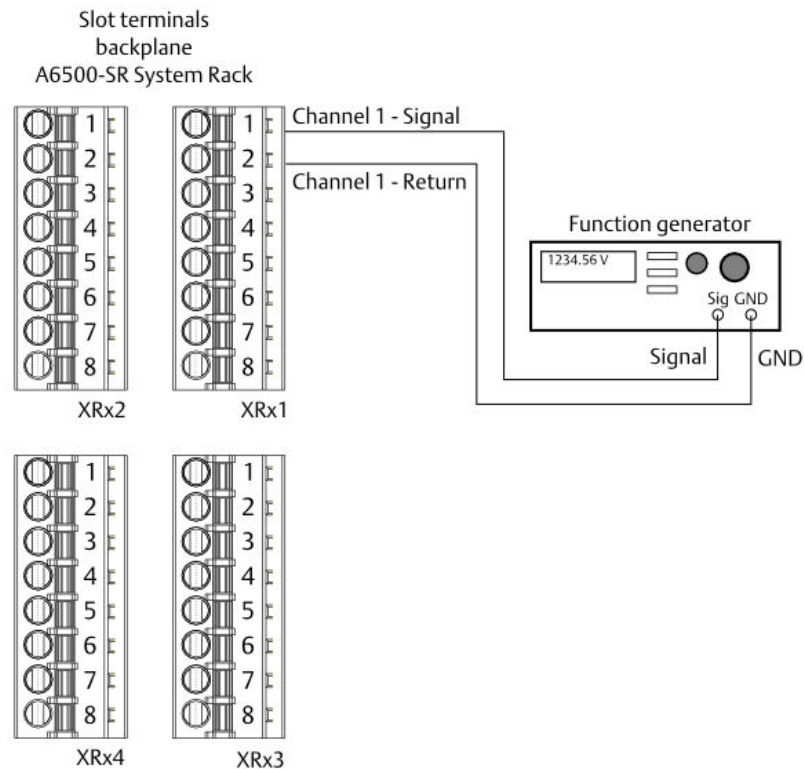

x = slot number 1 to 11

Note

To avoid system disturbances, ensure that:

- the output of the function generator is galvanically separated from protective ground.
- the generated signal does not exceed the specified electrical data of the sensor input (see [Sensor connection](#)).

Simulation of a relative shaft vibration signal - eddy current measuring chain

Signals of eddy current measuring chains consists of a DC and AC part. The DC part refers to the distance between shaft and sensor and is for shaft vibration measurement approximately the middle of the static range, for example -10V. The AC part refers to the shaft vibration signal.

Procedure

1. If a sensor is already connected to the channel to be tested disconnect this sensor.
2. Connect a function generator to the sensor input.

For terminal description see A6500-xR System Racks manual.

3. Generate a signal with the function generator appropriate to the configured measuring task.
 - a) Calculate the necessary signal amplitude with the following formula:

$$U_p = \text{Measurement value} * \text{Sensitivity}$$

Example

Example for vibration value 100 μm and sensitivity 8 mV/ μm :

$$U_p = 100 \mu\text{m} * 8 \frac{\text{mV}}{\mu\text{m}} = 800 \text{ mV}$$

- b) Generate a sinusoidal signal with a DC part of -10V, the calculated signal amplitude, and a frequency in the configured frequency range.

Example

DC part: -10 V, amplitude (AC part): 800 mV, frequency: 80 Hz

4. In AMS Machine Studio, check the vibration value displayed in the online view. The value displayed in the online view must agree with the simulated value. Note the configured signals evaluation, for example: zero-peak.
5. Vary the amplitude within the configured measuring range to check alarm limits and current output if configured. Corresponding digital alarm outputs must switch if the simulated signal exceeds the limits. The current output must show a current according to the displayed measurement value.
6. Reconnect the sensor after the test.

Simulation of an absolute bearing vibration signal - piezoelectric sensor

Signals of piezoelectric sensors consist of a DC and AC part. The DC part is the bias voltage and the AC part refers to the vibration signal.

Procedure

1. If a sensor is already connected to the channel to be tested disconnect this sensor.
2. Connect a function generator to the sensor input.
For terminal description see A6500-xR System Racks manual.
3. Generate a signal with the function generator appropriate to the configured measuring task.
 - a) Calculate the necessary signal amplitude with the following formula:

$$U_p = \text{Measurement value} * \text{Sensitivity}$$

Example

Vibration value 5 g and sensitivity 100 mV/g:

$$U_p = 5 g * 100 \frac{mV}{g} = 500 mV$$

- b) Generate a sinusoidal signal with a DC part of +10V, the calculated signal amplitude, and a frequency in the configured frequency range.

Example

DC part: +10 V, amplitude (AC part): 500 mV, frequency: 80 Hz

- In AMS Machine Studio, check the vibration value displayed in the online view. The value displayed in the online view must agree with the simulated value. Note the configured signals evaluation, for example: zero-peak.
- Vary the amplitude within the configured measuring range to check alarm limits and current output if configured. Corresponding digital alarm outputs must switch if the simulated signal exceeds the limits. The current output must show a current according to the displayed measurement value.
- Reconnect the sensor after the test.

Simulation of an absolute bearing vibration signal - seismic sensor

Signals of seismic sensors consist of an AC part, which is related to the bearing vibration signal.

Procedure

- If a sensor is already connected to the channel to be tested disconnect this sensor.
- Connect a function generator to the sensor input.
For terminal description see A6500-xR System Racks manual.
- Generate a signal with the function generator appropriate to the configured measuring task.
 - Calculate the necessary signal amplitude with the following formula:

$$U_p = \text{Measurement value} * \text{Sensitivity} * \sqrt{2}$$

Example

Vibration value 10 mm/s and sensitivity 28.5 mV/mm/s:

$$U_p = 10 \frac{mm}{s} * 28.5 \frac{mVs}{mm} * \sqrt{2} = 403 mV$$

- b) Generate a sinusoidal signal with the calculated signal amplitude and a frequency in the configured frequency range.

Example

Amplitude (AC part): 403 mV, frequency: 80 Hz

4. In AMS Machine Studio, check the vibration value displayed in the online view. The value displayed in the online view must agree with the simulated value. Note the configured signals evaluation, for example: rms.
5. Vary the amplitude within the configured measuring range to check alarm limits and current output if configured. Corresponding digital alarm outputs must switch if the simulated signal exceeds the limits. The current output must show a current according to the displayed measurement value.
6. Reconnect the sensor after the test.

Simulation of a shaft position signal - eddy current measuring chain

Signals of eddy current measuring chains consists of a DC and AC part. Only the DC part of the sensor signal is used for the shaft position measurement.

Procedure

1. If a sensor is already connected to the channel to be tested disconnect this sensor.
2. Connect a function generator to the sensor input.
For terminal description see A6500-xR System Racks manual.
3. Generate a signal with the function generator appropriate to the configured measuring task.
 - a) Calculate the necessary DC voltage signal with the following formula:

$$U = U_{\text{zero}} - \text{Measurement value} * \text{Sensitivity}$$

Example

Position value -0.5 mm, voltage zero point of the measuring range $U_{\text{zero}} = -10$ V and sensitivity 8 V/mm:

$$U = -10 \text{ V} - (-0.5 \text{ mm}) * 8 \frac{\text{V}}{\text{mm}} = -6 \text{ V}$$

- b) Generate a DC voltage signal with the calculated voltage level.

Example

DC voltage: -6 V

4. In AMS Machine Studio, check the position value displayed in the online view. The value displayed in the online view must agree with the simulated value.
5. Vary the DC voltage level within the configured measuring range to check alarm limits and current output if configured. Corresponding digital alarm outputs must switch if the simulated signal exceeds the limits. The current output must show a current according to the displayed measurement value.
6. Reconnect the sensor after the test.

Simulation of a case/housing expansion - A6500-LC with fixed sensitivity

The output signal of the A6500-LC is a positive DC voltage related to the linear expansion/ position of the measuring object. If the A6500-LC is calibrated to the sensor use the sensitivity stated in the calibration sheet otherwise use the fix sensitivity stated in the A6500-LC operation manual.

Procedure

1. Disconnect the A6500-LC from the channel to be tested.
2. Connect a function generator to the sensor input.
For terminal description see A6500-xR System Racks manual.
3. Generate a signal with the function generator appropriate to the configured measuring task.
 - a) Calculate the necessary DC voltage signal with the following formula:

$$U = \text{Measurement value} * \text{Sensitivity} + U_{\text{zero}}$$

Example

Position value -25.0 mm, voltage zero point of the measuring range $U_{\text{zero}} = 10 \text{ V}$ and sensitivity 0.216 V/mm (output voltage range divided by measuring range):

$$U = -25 \text{ mm} * 0.216 \frac{\text{V}}{\text{mm}} + 10 \text{ V} = 4.6 \text{ V}$$

- b) Generate a DC voltage signal with the calculated voltage level.

Example

DC voltage: 4.6 V

4. In AMS Machine Studio, check the position value displayed in the online view. The value displayed in the online view must agree with the simulated value.
5. Vary the DC voltage level within the configured measuring range to check alarm limits and current output if configured.
Corresponding digital alarm outputs must switch if the simulated signal exceeds the limits. The current output must show a current according to the displayed measurement value.
6. Reconnect the sensor after the test.

Simulation of speed - eddy current measurement chain or Hall-effect sensors

Procedure

1. Disconnect any sensor from the channel to be tested.
2. Connect a function generator to the sensor input.

For terminal description see A6500-xR System Racks manual.

3. Generate a signal with the function generator appropriate to the configured measuring task.
 - a) Calculate the necessary signal frequency with the following formula:

$$\text{Frequency} = \frac{\text{Speed} * \text{Number of teeth}}{60 \text{ s}}$$

Example

Speed 3000 rpm, and number of teeth 32

$$\text{Frequency} = \frac{3000 \text{ rpm} * 32}{60 \text{ s}} = 1600 \text{ Hz}$$

- b) Generate a signal with the calculated frequency and an amplitude that exceeds the configured trigger levels. Figure 10-2 shows a signal example. Use positive voltages if simulating a Hall-effect sensor.

Figure 10-2: Function generator signal

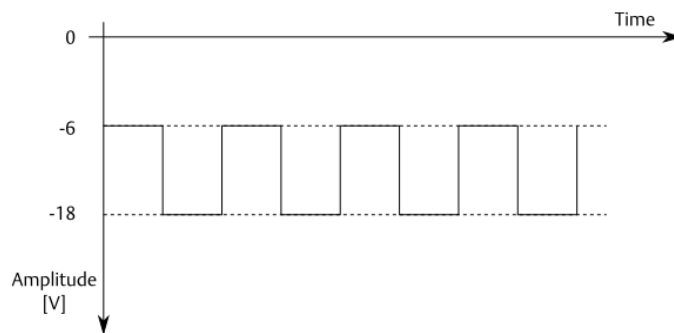

4. Check the speed value displayed in the online view of the configuration software. The value displayed in the online view must agree with the simulated value.
5. Vary the signal frequency within the configured measuring range to check alarm limits and current output, if configured. Corresponding digital alarm outputs must switch if the simulated signal exceeds the limits. The current output must show a current according to the displayed measurement value.
6. Reconnect the sensor after the test.

10.1.2 Measure the current output

Procedure

1. Measure with a DC ammeter the current at the corresponding current output terminals of the backplane. For connection terminals see A6500-xR System Racks operation manual.

2. Compare the measured current value with the value displayed in the online view of Machinery Studio (see [Details](#)).

The measured current must corresponds to the current value displayed in the online view.

10.1.3 Simulation mode

Use the simulation mode to check the behavior of digital outputs and current outputs by simulating measurement values. The simulation also affects the Modbus registers and the OPC UA items. The simulation mode can be used for several A6500-UM Universal Cards in parallel, so this mode can be also used to check the configured logic of an A6500-RC Relay Card.

Up to three AMS Machine Studio installations can simultaneously connect from different locations to one system rack. The simulation mode of one A6500-UM card can only be used by one connected AMS Machine Studio. It is not possible to start the simulation mode for an A6500-UM card by a second AMS Machine Studio connected to the system rack while a simulation is already active.

⚠ CAUTION

Any work on the system may impair machine protection.

⚠ CAUTION

Active simulation values replace measurement values and affect configured digital outputs, current outputs, Modbus registers, and OPC UA items. Take measures such as bypassing alarm outputs to avoid an unintentional switching off of the supervised equipment.

Figure 10-3: Simulation dialog

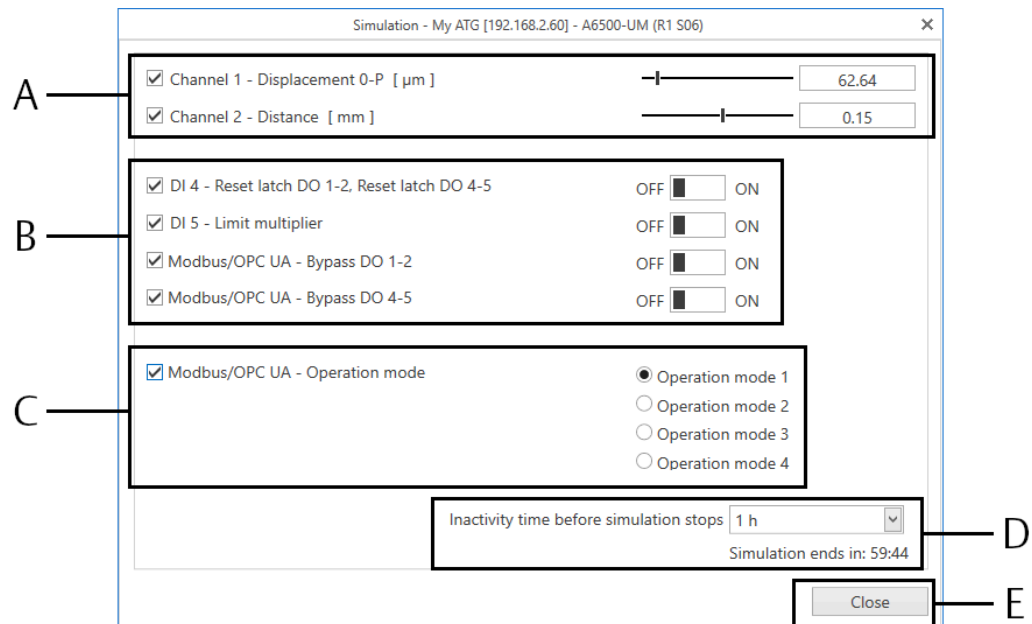

- A. Sliders to adjust the simulated measuring values
- B. Slide switches to simulate the digital inputs
- C. Selection buttons to simulate the operation mode
- D. Drop-down list to select an inactivity time
- E. Button to close the simulation

Measurement value	Place a checkmark in the box to enable the measurement value to be simulated. The calculated value is simulated at applications with calculations of both channels. The measurement value of the single channel is simulated at applications with separate channels. Move the slider assigned to the measurement value to be simulated or enter a value to set the desired measurement value, for example a value above a configured limit to check the alarm outputs. The initial value is the current measurement value.
Digital inputs	Place a checkmark in the box to enable the simulation of the assigned digital input. Only configured digital inputs are listed. The assigned slide switch indicates the current state of the digital input (Off or On). Click the slide switch to change the state of the digital input.
Software switches	Place a checkmark in the box to enable the simulation of the software switches. Only configured software switches are listed. The assigned slide switches indicate the current state of the software switch (Off or On). Click the slide switch to change the state of the software switch.
Operation mode	Place a checkmark in the box to enable the simulation of the operation mode. This option is available if operation modes are configured. Click one of the listed operation modes to activate it.

Inactivity time before simulation stops Select a time after that the simulation mode is automatically stopped. This time is reset if an element to be simulated (measurement value or digital input) is changed.

An active simulation does not change the configuration of the card. Digital outputs with activated **Limit suppression** and current outputs with activated **Current suppression** remain in their initial state if Channel OK is switched off.

Note

Do not change the configuration of the card while the simulation mode is active.

Prerequisites

Ensure that there is an online connection to the AMS 6500 ATG system.

Procedure

1. Select the A6500-UM Universal Card to be checked with the simulation mode from the device tree.
2. Press **Ctrl+Alt+M** to enable the maintenance mode.
The simulation button appears.
3. Click **Simulation** to open the simulation dialog of the selected card.

Figure 10-4: Simulation



4. Place a checkmark in the boxes assigned to the values and digital inputs to be simulated.
5. Move the slider to simulate a measurement value or enter a specific value in the entry field.
The change takes effect immediately.
6. Click the slide switches to change the state of the digital inputs.
The changes take effect immediately.
7. Select an inactivity time to automatically stop the simulation.
8. Check the behavior of the digital outputs and analog outputs.
9. Click **Close** to close the simulation dialog.
The simulation is stopped and the real values and states are used for driving the outputs again.

Note

The simulation is automatically stopped when the connection between AMS Machine Studio and the A6500-CC card is interrupted or AMS Machine Studio is closed.

10.2 Maintenance

The A6500-UM Universal Measurement Card does not require any maintenance during normal operation.

11 Replace an Universal Measurement Card

Follow the steps listed below if an A6500-UM Universal Measurement Card needs to be replaced, for example, due to a defect.

⚠ CAUTION

Any work at the system may impair machine protection.

Procedure

1. Save the card configuration, if possible.
 - a) Connect the configuration device (PC/Laptop) through USB or Ethernet connection to the A6500-CC Com Card.
 - b) Start the AMS Machine Studio configuration software. If connected through USB, the software automatically connects to the AMS 6500 ATG rack and opens the rack view. If connected through Ethernet, click **Connect ATG-System** to establish the connection.
 - c) Double-click the card to be replaced. The online view of the card opens.
 - d) Click **Configure** to open the configuration of the card.
 - e) Save the configuration file. Go to **File** and select **Save as**.
 - f) Go back to the editor and close it.
Do not close AMS Machine Studio.
2. At the System Rack, unfasten both screws at the front plate of the card to be replaced (see [Figure 3-2](#)).
3. Remove the card from the slot.
4. Install the new card.
5. Fasten the screws at the front plate to secure the card in the slot.
The card will be automatically detected by AMS Machine Studio if the System Rack is still powered.
6. Load the configuration from the memory of the configuration device into the card. If, due to a defect, there was no possibility of reading the configuration from the card to be replaced, use a back-up configuration file or create a new configuration.
 - a) Select the replaced card in the rack view. Double-click the new card to open the online view.
 - b) Click **Configure** to open the configuration of the card.
 - c) Open the saved configuration file. Go to **File** and select **Open**.
 - d) Click **Send & close** to send the configuration to the new card.

Now, the new card is ready for operation.

12 Technical data

Only specifications with indicated tolerances or limit values are binding. Data without tolerances or without error limits are informative data and not guaranteed. Technical modifications, especially of the software, are subject to changes without notice. If not specified otherwise, all data refer to an environmental temperature of +25°C.

12.1 Power supply

Nominal voltage	+24 V DC	redundant supply voltage inputs protected against polarity reversal
Permissible voltage range	+19 V to +32 V DC	in case of a single failure, supply voltage must not exceed the level of IEC 60204-1 or IEC 61131-2 (SELV/PELV)
Overvoltage protection	> +33 V DC	card shuts down at overvoltage condition
Power consumption	6 W	Test condition: All current outputs at full load, eddy current converter (10 mA) respectively Hall-effect sensors (25 mA) connected to sensor supply, all outputs active (exterior load currents of digital outputs and pulse outputs must be considered separately)

12.2 Sensor connection

Sensor input		
Number of inputs	2	independently configurable for different sensor types nonreactive
Sensor supply XR _x 1: 3,4 and XR _x 2: 3,4	0 to +30V or	depending on connected sensor type, see below for details
	0 to -30 V or	
	+/- 15 V	
Rated current XR _x 1: 3,4 and XR _x 2: 3,4	35 mA	
Rated power XR _x 1: 3,4 and XR _x 2: 3,4	1.05 W	
Sensor supply XR _x 1: 1,2 and XR _x 2: 1,2	0 to +30V or	depending on connected sensor type, see below for details
	0 to -30 V or	

Sensor input		
	+/- 15 V	
Rated current XR _x 1: 1,2 and XR _x 2: 1,2	0.3 mA	
Rated power XR _x 1: 1,2 and XR _x 2: 1,2	0.9 mW	
Resolution	24 bit ADC	
Accuracy	±1% of full scale	For definition of full scale see different sensor adaption input ranges
Noise floor	-90 dB	at shorted inputs
Impedance	>100 kΩ	
Temperature drift	±0.5% of full scale	within operating temperature range of -20°C to +70°C

Sensor raw signal		
One output per sensor input, nonreactive, and short circuit proof		
Voltage		according to sensor signal
Rated current	2 mA	
Rated power	60 mW	
Accuracy	±1% of full scale	for connected devices with input impedance >100kΩ
Phase shift	<5° <15°	frequencies up to 2000 Hz frequencies up to 18750 Hz
Temperature drift	±1% of full scale	within operating temperature range of -20°C to +70°C
Frequency range	0 to 18750 Hz	attenuation <1dB

Sensor adaption eddy current measuring chain		
Input signal and raw signal voltage range	-1 V to -22 V	
Frequency range	0 to 18750 Hz	attenuation <0.1 dB
Supply voltage	-23.25 V/-26.0 V DC	selectable short circuit proof
Maximum supply load	35 mA	
Supply accuracy	±1%	
Supply load variation	±1%	for loads 0 to 100%
Supply temperature drift	±1%	within operating temperature range of -20°C to +70°C
Connection	XR _x 1.1 and XR _x 1.2	sensor signal, channel 1

Sensor adaption eddy current measuring chain		
	XR _x .2.1 and XR _x 2.2	sensor signal, channel 2
	XR _x 1.3 and XR _x 1.4	converter supply, channel 1
	XR _x 2.3 and XR _x 2.4	converter supply, channel 2

Sensor adaption piezoelectric sensor and piezoelectric dynamic pressure sensor with integrated charge amplifier		
Input signal and raw signal voltage range	+1 V to +23 V	
Frequency range	0 to 18750 Hz	attenuation <0.1 dB
Supply constant current	0 to 8mA	adjustable selectable as 2-wire or 4-wire connection
Supply gain accuracy	±3.5%	
Supply offset accuracy	+100µA/-0µA	
Supply voltage reserve	+25 V	
Supply temperature drift	±50µA	within operating temperature range of -20°C to +70°C
Connection	XR _x 1.1 and XR _x 1.2	sensor supply and signal, channel 1
	XR _x 2.1 and XR _x 2.2	sensor supply and signal, channel 2

Sensor adaption dynamic pressure sensor with external charge amplifier, externally supplied		
Input signal and raw signal voltage range	+1 V to +23 V	
Frequency range	0 to 18750 Hz	attenuation <0.1 dB
Connection	XR _x 1.1 and XR _x 1.2	Sensor signal, channel 1
	XR _x 2.1 and XR _x 2.2	Sensor signal, channel 2

Sensor adaption seismic (electro dynamic) sensor		
Input signal and raw signal voltage range	-10 V to +15 V	
Frequency range	0 to 2000 Hz	attenuation <0.1 dB
Supply lifting current	0 to 8 mA	adjustable selectable as 2-wire or 4-wire connection
Supply gain accuracy	±3.5%	
Supply offset accuracy	+100 µA/-0 µA	
Supply voltage reserve	+12 V	

Sensor adaption seismic (electro dynamic) sensor		
Supply temperature drift	±50 µA	within operating temperature range of -20°C to +70°C
Connection	XRx1.1 and XRx1.2	sensor supply ¹ and signal, channel 1
	XRx2.1 and XRx2.2	sensor supply ¹ and signal, channel 2

¹ If sinking or lifting current is required.

Sensor adaption LF (low frequency bearing vibration) sensor		
Input signal and raw signal voltage range	-11 V to +11 V	
Frequency range	0 to 1000 Hz	attenuation <0.1 dB
Supply voltage	±15 V DC	short circuit proof
Maximum supply load	35 mA	
Supply accuracy	-5%	
Supply load variation	-12%	for loads 0 to 100%
Supply temperature drift	±3%	within operating temperature range of -20°C to +70°C
Connection	XRx1.1 and XRx1.2	sensor signal, channel 1
	XRx1.3 and XRx1.4	sensor supply, channel 1
	XRx1.5	GND
	XRx2.1 and XRx2.2	sensor signal, channel 2
	XRx2.3 and XRx2.4	sensor supply, channel 2
	XRx2.5	GND

Sensor adaption Hall-effect / A6500-LC		
Input signal and raw signal voltage range	+1 V to +22 V	
Extended input range	0V to +30V	Only valid for speed measurement, sensor raw signal will clip.
Frequency range	0 to 18750 Hz	attenuation <0.1 dB
Supply voltage	+30 V	short circuit proof
Maximum supply load	35 mA	
Supply accuracy	-10%	
Supply load variation	-12%	for loads 0 to 100%
Supply temperature drift	±3%	within operating temperature range of -20°C to +70°C

Sensor adaption Hall-effect / A6500-LC		
Connection	XRx1.1 and XRx1.2	sensor signal, channel 1
	XRx1.3 and XRx1.4	sensor supply, channel 1
	XRx2.1 and XRx2.2	sensor signal, channel 2
	XRx2.3 and XRx2.4	sensor supply, channel 2

Sensor adaption VR sensors		
Input signal range and raw signal voltage range	-22 V to +22V	clipping limit range for the sensor raw signal -15 V to +15 V
Maximum sensor input range	-30 V to +30V	sensors with higher nominal voltages must be connected through a Zener barrier to protect the input
Frequency range	0 to 18750 Hz	attenuation <0.1 dB
Sensor impedance	110 Ω to 10 kΩ	sensor health detection may be reduced if the sensor impedance is out of this range
Connection	XRx1.1 and XRx1.2	sensor signal, channel 1
	XRx2.1 and XRx2.2	sensor signal, channel 2

12.3 Digital input

Number of inputs	5	
Logic low level	0 V to 3 V	active
Logic high level	13 V to 32 V, open	not active
Load	<1 mA	
Rated current	1 mA	
Rated power	24 mW	
Inputs for key-signals	2	two of the five inputs (DI 1 and DI 2) can be used for key-signal inputs
Key-signal frequency range	0 to 2000 Hz	at duty cycle 20 to 80%

12.4 Outputs

Current output		
Number of current outputs	2	
Range	0/4 to 20 mA	
Accuracy	± 1% of full scale	

Current output		
Maximum load	<500 Ω	
Rated voltage	10 V	
Rated power	0.2 W	
Temperature drift	±1% of full scale	within operating temperature range of -20°C to +70°C

Digital output		
Number of digital outputs	6	solid state relay
Type	normally open	equivalent to SPST Protected against polarity reversal
Voltage capability	19 V to 32 V DC	
Maximum load	100 mA	
Rated current	100 mA	
Rated power	2.4 W	
Turn-on / turn-off time	<5 ms	at 20kΩ load (without alarm detection time as configured delays, filter settings, and so on)

Pulse output		
Number of pulse outputs	2	
Type	normally open	opto-decoupled collector-emitter output protected against polarity reversal
Voltage capability	19 V to 32 V DC	
Maximum load	30 mA	
Frequency range	0 to 2000 Hz	at 50% duty cycle
Additional pull-up voltage	19 V to 32 V DC	short circuit proof
Fan-out	21	key-signal inputs of A6500-UM at pull-up voltage of 24 V DC

12.5 Data interface

Communication bus	RS 485	according to EIA485 standard
Bus termination	exterior	bus termination according to EIA485 can be provided externally

12.6 Mechanical design and environmental conditions

Mechanical design		
Rack slot	3RU/6HP	
Material front panel	aluminum, clear anodized	
Board dimensions	100x160 mm	euro-card format conform to IEC 60297
Board coating	Airborne contaminants resistance	ISA-S71.04-1985 airborne contaminants class G3, Conformal Coating
	Material: HumiSeal® 1B31 EPA	according to IPC-CC-830B and IPC-A 610
Card connector I/O	type F48 male	according to IEC 60603-2
front connector sensor raw signal	SMB	jack receptacle
Status indication	LED (3mm)	two green OK LEDs and two red Alarm LEDs at front panel
Weight	approximately 200 g	without packaging
Overall dimensions		see Figure 12-1

Environmental conditions		
Protection class	IP20	according to IEC 60529 rack mounted, otherwise IP00
Approval class for general safety	Class 2253 01	industrial automation products
	Class 2253 81	industrial automation products - (certified to U.S. standards)
Allowed degree of pollution	Category 2	according to IEC 61010-1
Operating temperature	-20°C to +70°C	with forced cooling ¹
	-20°C to +55°C	without forced cooling
Storage temperature	-40°C to +85°C	
Relative humidity	5 to 95%	noncondensing
Shock	150 m/s ²	according to IEC 60068-2-27, 4000 shocks per axis
Vibration	0.15 mm	10 to 55 Hz
	20 m/s ²	55 to 150 Hz according to IEC 60068-2-6, float sinus, three axis
Operating altitude	<2000 m	above sea level
Environmental Area	Indoor use only	

Environmental conditions		
External devices		in case of a single failure, externally connected devices must not exceed the level of IEC 60204-1 or IEC 61131-2

¹ An airflow of $\geq 440 \text{ m}^3/\text{h}$ is required.

Figure 12-1: Dimensions

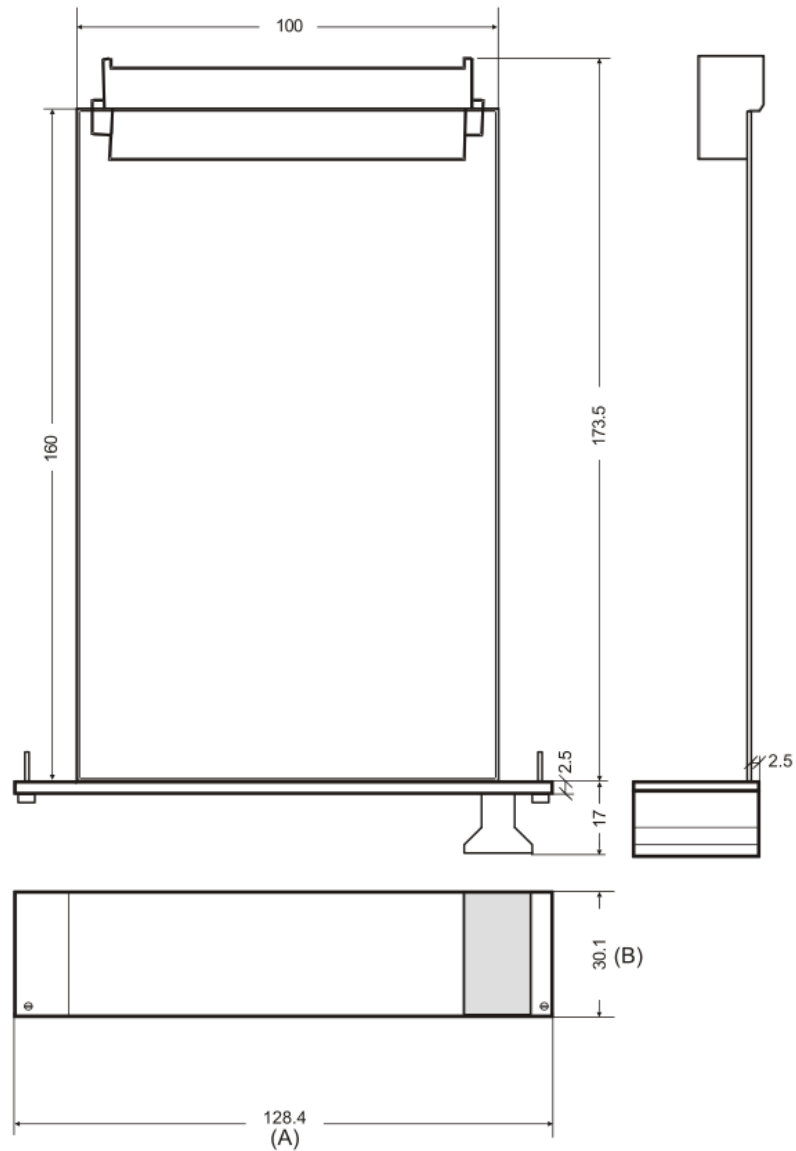

- A. 3 RU
- B. 6 HP

All dimensions in mm

13 Certificates



EU-Declaration of Conformity (Translation)

We: epro GmbH, Jöbkesweg 3, 48599 Gronau
declare under our sole responsibility that following product(s):

Product designation:	AMS 6500 ATG
Product description:	Protection system for rotating equipment with integrated prediction capabilities
Part numbers	A6500-CC A6500-UM A6500-TP A6500-RC A6500-SR A6500-RR A6500-FR

are in conformity with the terms of the directives mentioned below including any amendment valid at the date of declaration:

2014/30/EU	Electromagnetic compatibility
2014/34/EU	Equipment and protective system intended for use in potentially explosive atmospheres
2011/65/EU	The restriction of the use of certain hazardous substances in electrical and electronic equipment

Following harmonized standards have been applied:

2014/30/EU	EN 61326-1	Electrical equipment for measurement, control and laboratory use. EMC requirements. Part 1: General requirements
2014/34/EU	EN 60079-0	Explosive atmospheres - Part 0: Equipment - General requirements
	EN 60079-7	Explosive atmospheres - Part 7: Equipment protection by increased safety "e"
2011/65/EU	EN 63000	Technical documentation for the assessment of electrical and electronic products with respect to the restriction of hazardous substances

For the type examination according to EN 60079-0 and EN 60079-7 the following notified body has been involved;

DEKRA EXAM GmbH
Type examination certificate BVS 16 ATEX E 016 U

Authorized person for technical documentation:
Bruno Hecker, Jöbkesweg 3, 48599 Gronau

Gronau, 06 May 2022
Place, Date

Managing Director

Quality



EU-Konformitätserklärung (Original)



Wir: epro GmbH, Jöbkesweg 3, 48599 Gronau
erklären in alleiniger Verantwortung, dass folgende Produkte:

Produktbezeichnung: AMS 6500 ATG
Produktbeschreibung: Schutzsystem für rotierende Maschinen mit integrierten Diagnosemöglichkeiten
Artikelnummern: A6500-CC
A6500-UM
A6500-TP
A6500-RC
A6500-SR
A6500-RR
A6500-FR

den Bestimmungen der unten genannten Richtlinien, einschließlich deren zum Zeitpunkt der Erklärung geltenden Änderungen, entsprechen:

2014/30/EU	Elektromagnetische Verträglichkeit
2014/34/EU	Geräte und Schutzsysteme zur bestimmungsgemäßen Verwendung in explosionsgefährdeten Bereichen
2011/65/EU	Beschränkung der Verwendung bestimmter gefährlicher Stoffe in Elektro- und Elektronikgeräten

Folgende harmonisierte Normen wurden angewandt:

2014/30/EU	EN 61326-1	Elektrische Mess-, Steuer-, Regel- und Laborgeräte – EMV Anforderungen - Teil 1: Allgemeine Anforderungen
2014/34/EU	EN 60079-0	Explosionsgefährdete Bereiche - Teil 0: Betriebsmittel – Allgemeine Anforderungen
	EN 60079-7	Explosionsgefährdete Bereiche - Teil 7: Geräteschutz durch erhöhte Sicherheit "e"
2011/65/EU	EN 63000	Technische Dokumentation zur Beurteilung von Elektro- und Elektronikgeräten hinsichtlich der Beschränkung gefährlicher Stoffe

Für die Baumusterprüfung nach EN 60079-0 und EN 60079-7 ist folgende Benannte Stelle eingeschaltet worden:

DEKRA EXAM GmbH
Baumusterprüfnummer BVS 16 ATEX E 016 U

Bevollmächtigter für die Technische Dokumentation:

Bruno Hecker, Jöbkesweg 3, 48599 Gronau

Gronau, 06. Mai 2022
Ort, Datum

Geschäftsführung

Qualitätsmanagement



UKCA-Declaration of Conformity

We, the manufacturer: epro GmbH, Jöbkesweg 3, 48599 Gronau, Germany
declare under our sole responsibility that following product(s):

Product designation:	AMS 6500 ATG
Product description:	Protection system for rotating equipment with integrated prediction capabilities
Part numbers	A6500-CC A6500-UM A6500-TP A6500-RC A6500-SR A6500-RR

are in conformity with the terms of the directives mentioned below including any amendment valid at the date of declaration:

S.I. 2016 No. 1091	Electromagnetic Compatibility Regulations 2016
S.I. 2016 No. 1107	Equipment and Protective Systems Intended for use in Potentially Explosive Atmospheres Regulations 2016
S.I. 2012 No. 3032	The restriction of the use of certain hazardous substances in electrical and electronic equipment

Following standards have been applied:

S.I. 2016 No. 1091	EN 61326-1	Electrical equipment for measurement, control and laboratory use. EMC requirements. Part 1. General requirements
S.I. 2016 No. 1107	EN 60079-0	Explosive atmospheres -Part 0: Equipment- General requirements
	EN 60079-7	Explosive atmospheres - Part 7: Equipment protection by increased safety "e"
S.I. 2012 No. 3032	EN IEC 63000	Technical documentation for the assessment of electrical and electronic products with respect to the restriction of hazardous substances

For the type examination according to EN 60079-0 and EN 60079-7 the following notified body has been involved:

DEKRA Testing and Certification GmbH
Type examination certificate BVS 16 ATEX E 016 X

Authorized person for technical documentation:

Bruno Hecker, Jöbkesweg 3, 48599 Gronau, Germany

Authorized Representative:

Emerson Process Management Limited,
company No 00671801
Meridian East,
Leicester
LE19 1UX, United Kingdom
Regulatory Compliance Department
email: ukproductcompliance@emerson.com
Phone: +44 11 6282 23 64

M. Fränzer
Managing Director

B. Hecker
Quality

Place, Date: Gronau, 13 September 2022



Emerson Process Management
1100 W. Louis Henna Blvd.
Round Rock, TX 78681

Statement Regarding the China RoHS Compliance of Emerson Product – A6500-UM

Please refer to Table 1 for the names and contents of the toxic or hazardous substances or elements contained in Emerson products.

Table 1: Names and Contents of Toxic or Hazardous Substances or Elements
表1：有毒有害物质或元素的名称及含量

部件名称 Part Name	有毒有害物质或元素 Toxic or hazardous Substances and Elements						
	铅 Lead (Pb)	汞 Mercury (Hg)	镉 Cadmium (Cd)	六价铬 Hexavalent Chromium (Cr (VI))	多溴联苯 Polybrominated biphenyls (PBB)	多溴二苯醚 Polybrominated diphenyl ethers (PBDE)	
印刷电路板组装 PC BD ASSY	X	0	0	0	0	0	
面板 FACEPLATE	0	0	0	0	0	0	
印刷电路板组装支持 PC BD ASSY SUPPORT	0	0	0	0	0	0	
<p>0 表示该有毒有害物质在该部件所有均质材料中的含量均在GB/T 26572规定的限量要求以下 0: Indicates that this toxic or hazardous substance contained in all of the homogeneous materials for this part is below the limit requirement in GB/T 26572.</p> <p>X 表示该有毒有害物质至少在该部件的某一均质材料中的含量超出GB/T 26572规定的限量要求。 X: Indicates that this toxic or hazardous substance contained in at least one of the homogeneous materials used for this part is above the limit requirement in GB/T 26572</p> <p>环保期限 (EFUP) 的产品及其部件是每个列出的符号，除非另有标明。使用期限只适用于产品在产品手册中规定的条件下工作 The Environmentally Friendly Period (EFUP) for the product and its parts are per the symbol listed, unless otherwise marked. Use Period is valid only when the product is operated under the conditions defined in the product manual.</p>							

James McFerrin
Environmental Compliance Manager PSG
T 512.832.3271 E james.mcferrin@emerson.com



Emerson Process Management
1100 W. Louis Henna Blvd.
Round Rock, TX 78681

Statement Regarding the China RoHS Compliance of Emerson Product – A6500-TP

Please refer to Table 1 for the names and contents of the toxic or hazardous substances or elements contained in Emerson products.

Table 1: Names and Contents of Toxic or Hazardous Substances or Elements

表1：有毒有害物质或元素的名称及含量

部件名称 Part Name	有毒有害物质或元素 Toxic or hazardous Substances and Elements						
	铅 Lead (Pb)	汞 Mercury (Hg)	镉 Cadmium (Cd)	六价铬 Hexavalent Chromium (Cr (VI))	多溴联苯 Polybrominated biphenyls (PBB)	多溴二苯醚 Polybrominated diphenyl ethers (PBDE)	
印刷电路板组装 PC BD ASSY	X	0	0	0	0	0	
面板 FACEPLATE	0	0	0	0	0	0	
印刷电路板组装支持 PC BD ASSY SUPPORT	0	0	0	0	0	0	
<p>0 表示该有毒有害物质在该部件所有均质材料中的含量均在GB/T 26572规定的限量要求以下 0: Indicates that this toxic or hazardous substance contained in all of the homogeneous materials for this part is below the limit requirement in GB/T 26572.</p> <p>X 表示该有毒有害物质至少在该部件的某一均质材料中的含量超出GB/T 26572规定的限量要求。 X: Indicates that this toxic or hazardous substance contained in at least one of the homogeneous materials used for this part is above the limit requirement in GB/T 26572</p> <p>环保期限 (EFUP) 的产品及其部件是每个列出的符号，除非另有标明。使用期限只适用于产品在产品手册中规定的条件下工作 The Environmentally Friendly Period (EFUP) for the product and its parts are per the symbol listed, unless otherwise marked. Use Period is valid only when the product is operated under the conditions defined in the product manual.</p>							

James McFerrin
Environmental Compliance Manager PSG
T 512.832.3271 E james.mcferrin@emerson.com



Emerson Process Management
1100 W. Louis Henna Blvd.
Round Rock, TX 78681

Statement Regarding the China RoHS Compliance of Emerson Product – A6500-RC

Please refer to Table 1 for the names and contents of the toxic or hazardous substances or elements contained in Emerson products.

Table 1: Names and Contents of Toxic or Hazardous Substances or Elements

表1：有毒有害物质或元素的名称及含量

部件名称 Part Name	有毒有害物质或元素 Toxic or hazardous Substances and Elements						
	铅 Lead (Pb)	汞 Mercury (Hg)	镉 Cadmium (Cd)	六价铬 Hexavalent Chromium (Cr (VI))	多溴联苯 Polybrominated biphenyls (PBB)	多溴二苯醚 Polybrominated diphenyl ethers (PBDE)	
印刷电路板组装 PC BD ASSY	X	0	0	0	0	0	
面板 FACEPLATE	0	0	0	0	0	0	
印刷电路板组装支持 PC BD ASSY SUPPORT	0	0	0	0	0	0	
<p>0 表示该有毒有害物质在该部件所有均质材料中的含量均在GB/T 26572规定的限量要求以下 0: Indicates that this toxic or hazardous substance contained in all of the homogeneous materials for this part is below the limit requirement in GB/T 26572.</p> <p>X 表示该有毒有害物质至少在该部件的某一均质材料中的含量超出GB/T 26572规定的限量要求。 X: Indicates that this toxic or hazardous substance contained in at least one of the homogeneous materials used for this part is above the limit requirement in GB/T 26572</p> <p>环保期限 (EFUP) 的产品及其部件是每个列出的符号，除非另有标明，使用期限只适用于产品在产品手册中规定的条件下工作 The Environmentally Friendly Period (EFUP) for the product and its parts are per the symbol listed, unless otherwise marked. Use Period is valid only when the product is operated under the conditions defined in the product manual.</p>							

James McFerrin
Environmental Compliance Manager PSG
T 512.832.3271 E james.mcferrin@emerson.com



Emerson Process Management
1100 W. Louis Henna Blvd.
Round Rock, TX 78681

Statement Regarding the China RoHS Compliance of Emerson Product – A6500-CC

Please refer to Table 1 for the names and contents of the toxic or hazardous substances or elements contained in Emerson products.

Table 1: Names and Contents of Toxic or Hazardous Substances or Elements

表1：有毒有害物质或元素的名称及含量

部件名称 Part Name	有毒有害物质或元素 Toxic or hazardous Substances and Elements						
	铅 Lead (Pb)	汞 Mercury (Hg)	镉 Cadmium (Cd)	六价铬 Hexavalent Chromium (Cr (VI))	多溴联苯 Polybrominated biphenyls (PBB)	多溴二苯醚 Polybrominated diphenyl ethers (PBDE)	
印刷电路板组装 PC BD ASSY	X	0	0	0	0	0	
面板 FACEPLATE	0	0	0	0	0	0	
印刷电路板组装支持 PC BD ASSY SUPPORT	0	0	0	0	0	0	
0 表示该有毒有害物质在该部件所有均质材料中的含量均在GB/T 26572规定的限量要求以下 0: Indicates that this toxic or hazardous substance contained in all of the homogeneous materials for this part is below the limit requirement in GB/T 26572.							
X 表示该有毒有害物质至少在该部件的某一均质材料中的含量超出GB/T 26572规定的限量要求。 X: Indicates that this toxic or hazardous substance contained in at least one of the homogeneous materials used for this part is above the limit requirement in GB/T 26572.							
环保期限 (EFUP) 的产品及其部件是每个列出的符号，除非另有标明。使用期限只适用于产品在产品手册中规定的条件下工作 The Environmentally Friendly Period (EFUP) for the product and its parts are per the symbol listed, unless otherwise marked. Use Period is valid only when the product is operated under the conditions defined in the product manual.							

James McFerrin
Environmental Compliance Manager PSG
T 512.832.3271 E james.mcferrin@emerson.com



Emerson Process Management
1100 W. Louis Henna Blvd.
Round Rock, TX 78681

Statement Regarding the China RoHS Compliance of Emerson Product – A6500-SR

Please refer to Table 1 for the names and contents of the toxic or hazardous substances or elements contained in Emerson products.

Table 1: Names and Contents of Toxic or Hazardous Substances or Elements

表1：有毒有害物质或元素的名称及含量

部件名称 Part Name	有毒有害物质或元素 Toxic or hazardous Substances and Elements						
	铅 Lead (Pb)	汞 Mercury (Hg)	镉 Cadmium (Cd)	六价铬 Hexavalent Chromium (Cr (VI))	多溴联苯 Polybrominated biphenyls (PBB)	多溴二苯醚 Polybrominated diphenyl ethers (PBDE)	
印刷电路板组装 PC BD ASSY	X	0	0	0	0	0	
围堰 ENCLOSURE	0	0	0	0	0	0	
硬件 HARDWARE	0	0	0	0	0	0	
印刷电路板组装支持 PC BD ASSY SUPPORT	0	0	0	0	0	0	
0 表示该有毒有害物质在该部件所有均质材料中的含量均在GB/T 26572规定的限量要求以下 0: Indicates that this toxic or hazardous substance contained in all of the homogeneous materials for this part is below the limit requirement in GB/T 26572.							
X 表示该有毒有害物质至少在该部件的某一均质材料中的含量超出GB/T 26572规定的限量要求。 X: Indicates that this toxic or hazardous substance contained in at least one of the homogeneous materials used for this part is above the limit requirement in GB/T 26572.							
环保期限 (EFUP) 的产品及其部件是每个列出的符号，除非另有标明。使用期限只适用于产品在产品手册中规定的条件下工作 The Environmentally Friendly Period (EFUP) for the product and its parts are per the symbol listed, unless otherwise marked. Use Period is valid only when the product is operated under the conditions defined in the product manual.							

James McFerrin
Environmental Compliance Manager PSG
T 512 832 3271 E james.mcferrin@emerson.com



Emerson Process Management
1100 W. Louis Henna Blvd.
Round Rock, TX 78681

Statement Regarding the China RoHS Compliance of Emerson Product – A6500-RR

Please refer to Table 1 for the names and contents of the toxic or hazardous substances or elements contained in Emerson products.

Table 1: Names and Contents of Toxic or Hazardous Substances or Elements

表1：有毒有害物质或元素的名称及含量

部件名称 Part Name	有毒有害物质或元素 Toxic or hazardous Substances and Elements						
	铅 Lead (Pb)	汞 Mercury (Hg)	镉 Cadmium (Cd)	六价铬 Hexavalent Chromium (Cr (VI))	多溴联苯 Polybrominated biphenyls (PBB)	多溴二苯醚 Polybrominated diphenyl ethers (PBDE)	
印刷电路板组装 PC BD ASSY	X	0	0	0	0	0	
围堵 ENCLOSURE	0	0	0	0	0	0	
硬件 HARDWARE	0	0	0	0	0	0	
印刷电路板组装支持 PC BD ASSY SUPPORT	0	0	0	0	0	0	
<p>0 表示该有毒有害物质在该部件所有均质材料中的含量均在GB/T 26572规定的限量要求以下 0: Indicates that this toxic or hazardous substance contained in all of the homogeneous materials for this part is below the limit requirement in GB/T 26572.</p> <p>X 表示该有毒有害物质至少在该部件的某一均质材料中的含量超出GB/T 26572规定的限量要求。 X: Indicates that this toxic or hazardous substance contained in at least one of the homogeneous materials used for this part is above the limit requirement in GB/T 26572</p> <p>环保期限（EFUP）的产品及其部件是每个列出的符号，除非另有标明，使用期限只适用于产品在产品手册中规定的条件下工作 The Environmentally Friendly Period (EFUP) for the product and its parts are per the symbol listed, unless otherwise marked. Use Period is valid only when the product is operated under the conditions defined in the product manual.</p>							

James McFerrin
Environmental Compliance Manager PSG
T 512 832 3271 E james.mcferrin@emerson.com



Emerson Automation Solutions
1100 W. Louis Henna Blvd.
Round Rock, TX 78681

Statement Regarding the China RoHS Compliance of Emerson Product - A6500-FR

Please refer to Table 1 for the names and contents of the toxic or hazardous substances or elements contained in Emerson products.

Table 1: Names and Contents of Toxic or Hazardous Substances or Elements

表1：有毒有害物质或元素的名称及含量

部件名称 Part Name	有毒有害物质或元素 Toxic or hazardous Substances and Elements						
	铅 Lead (Pb)	汞 Mercury (Hg)	镉 Cadmium (Cd)	六价铬 Hexavalent Chromium (Cr (VI))	多溴联苯 Polybrominated biphenyls (PBB)	多溴二苯醚 Polybrominated diphenyl ethers (PBDE)	
印刷电路板组装 PC BD ASSY	X	0	0	0	0	0	
硬件 HARDWARE	0	0	0	0	0	0	
<p>0 表示该有毒有害物质在该部件所有均质材料中的含量均在GB/T 26572规定的限量要求以下 0: Indicates that this toxic or hazardous substance contained in all of the homogeneous materials for this part is below the limit requirement in GB/T 26572.</p> <p>X 表示该有毒有害物质至少在该部件的某一均质材料中的含量超出GB/T 26572规定的限量要求。 X: Indicates that this toxic or hazardous substance contained in at least one of the homogeneous materials used for this part is above the limit requirement in GB/T 26572</p> <p>环保期限 (EFUP) 的产品及其部件是每个列出的符号，除非另有标明。使用期限只适用于产品在产品手册中规定的条件下工作 The Environmentally Friendly Period (EFUP) for the product and its parts are per the symbol listed, unless otherwise marked. Use Period is valid only when the product is operated under the conditions defined in the product manual.</p>							

James McFerrin
Environmental Compliance Manager
Systems and Solutions
T 512 832 3271 E james.mcferrin@emerson.com



Emerson Automation Solutions
1100 W. Louis Henna Blvd.
Round Rock, TX 78681

Statement Regarding the China RoHS Compliance of Emerson Product - A6500-PE

Please refer to Table 1 for the names and contents of the toxic or hazardous substances or elements contained in Emerson products.

Table 1: Names and Contents of Toxic or Hazardous Substances or Elements

表1：有毒有害物质或元素的名称及含量

部件名称 Part Name	有毒有害物质或元素 Toxic or hazardous Substances and Elements						
	铅 Lead (Pb)	汞 Mercury (Hg)	镉 Cadmium (Cd)	六价铬 Hexavalent Chromium (Cr (VI))	多溴联苯 Polybrominated biphenyls (PBB)	多溴二苯醚 Polybrominated diphenyl ethers (PBDE)	
印刷电路板组装 C PC BD ASSY C	X	O	O	O	O	O	
印刷电路板组装 PC BD ASSY	X	O	O	O	O	O	
硬件 HARDWARE	O	O	O	O	O	O	
<p>O 表示该有毒有害物质在该部件所有均质材料中的含量均在GB/T 26572规定的限量要求以下 O: Indicates that this toxic or hazardous substance contained in all of the homogeneous materials for this part is below the limit requirement in GB/T 26572.</p> <p>X 表示该有毒有害物质至少在该部件的某一均质材料中的含量超出GB/T 26572规定的限量要求。 X: Indicates that this toxic or hazardous substance contained in at least one of the homogeneous materials used for this part is above the limit requirement in GB/T 26572</p> <p>环保期限 (EFUP) 的产品及其部件是每个列出的符号，除非另有标明。使用期限只适用于产品在产品手册中规定的条件下工作 The Environmentally Friendly Period (EFUP) for the product and its parts are per the symbol listed, unless otherwise marked. Use Period is valid only when the product is operated under the conditions defined in the product manual.</p>							

James McFerrin
Environmental Compliance Manager
Systems and Solutions
T 512 832 3271 E james.mcferrin@emerson.com

A Card related system events

The possible system events provided by the A6500-UM card are listed in [Table A-1](#). See column **Cross reference / Note** for further event related information. See Machine Studio – General Functions manual for a common description of the system events.

Table A-1: Card events

Event	Cross reference / Note
Alert alarm entered	Alarm limits 1 and Alarm limits 2
Alert alarm left	
Danger alarm entered	
Danger alarm left	
Channel OK entered	Channel OK supervision
Channel OK left	
Reset Latch Channel OK x entered ¹	Channel OK LEDs
Reset Latch Channel OK x left ¹	
Digital output x ² on	Digital outputs , Digital outputs
Digital output x ² off	
Limit suppression for 'Main evaluation (1)' entered	Alarm limits 1 and Alarm limits 2
Limit suppression for 'Main evaluation (1)' left	
Limit suppression for 'Main evaluation (2)' entered	
Limit suppression for 'Main evaluation (2)' left	
Limit suppression for 'Main evaluation' entered	
Limit suppression for 'Main evaluation' left	
Limit suppression for 'Analysis' entered	Limits for Peak and phase , Limits for Band Analysis , Limits for PeakVue analysis , Limits for Interval band by frequency analysis , Limits for Not 1st order analysis
Limit suppression for 'Analysis' left	
Speed range suppression for 'Main evaluation' entered	Optional parameter – measurement , see Out of speed range suppression mode
Speed range suppression for 'Main evaluation' left	
Speed range suppression for 'Main evaluation' and 'Current output' entered	
Speed range suppression for 'Main evaluation' and 'Current output' left	
Sensor OK left	Channel OK supervision
Sensor OK entered	
Sensor DC voltage OK left	Optional parameter – input , Channel OK supervision

Table A-1: Card events (continued)

Event	Cross reference / Note
Sensor DC voltage OK entered	
Sensor AC voltage OK left	
Sensor AC voltage OK entered	
Sensor AC voltage OK (delayed) left	
Sensor AC voltage OK (delayed) entered	
Temperature danger alarm entered	Table 7-2
Temperature danger alarm left	
Temperature alert alarm entered	
Temperature alert alarm left	
Card starts up	-/-
Card started up successfully	-/-
Warm start finished	Software initialized start of the card is completed.
Card reboots	-/-
Card configuration error	Try to send the configuration again, if this does not solve the problem, contact support, see Technical support .
Bus address assigned successfully	-/-
Bus address assigned failed	-/-
Connection to A6500-CC established	-/-
Connection to A6500-CC lost	-/-
Mismatched checksum detected (package re-sent)	If the event appears only once, then resending solved the issue. If the event appears more often, contact support, see Technical support .
Card configured and rebooted	Send a configuration
Card configured	
Reset min/max entered	Reset min/max values
Reset min/max left	
EEPROM error	Card health
ADC error	
Simulation mode activated	Simulation mode
Simulation mode deactivated	
Software switch activated	
Software switch deactivated	

Table A-1: Card events (continued)

Event	Cross reference / Note
Reset Latch CH 1 entered	Digital inputs
Reset Latch CH 1 left	
Reset Latch CH 2 entered	
Reset Latch CH 2 left	
Key triggered mode CH 1 entered	Measurement 1 and Measurement 2
Key triggered mode CH 1 left	
Collection Task event occurred	Digital inputs
Testvalue activated	Optional parameter - speed measurement
Testvalue deactivated	
Switched to secondary channel of 'Speed redundant'	Table 6-1, see application Redundant speed
Switched to primary channel of 'Speed redundant'	
Card bypass activated	Bypass
Card bypass deactivated	
Bypass DO 1-3 activated	
Bypass DO 1-3 deactivated	
Bypass DO 4-6 activated	
Bypass DO 4-6 deactivated	
Reset rotation direction entered	Reset rotation direction
Reset rotation direction left	
Operation mode value out of range	Basic
Reset Latch DO x ³ entered	Reset latch
Reset Latch DO x ³ left	
Key triggered mode CH 2 entered	Measurement 1 and Measurement 2
Key triggered mode CH 2 left	

1 x = 1 or 2

2 x = 1 to 6

3 x = 1, 2, 4, and 5

Index

A

A6500-CC 22
A6500-xR 20
Absolute bearing vibration
 low frequency 30
 Piezoelectric sensor 180
 Seismic sensors 177
Absolute shaft expansion 271
Absolute shaft vibration 26, 273
Acceleration 100, 168
Alarm limits 71
Analysis 62, 123
Application 16

B

Band
 Online view
 Details 133
Band analysis
 Limit 78
Basic 36
Bypass 172

C

Card health 123
Card replacement 294
CCC Certification 12
Channel OK 121
Channel OK (COK)
 LEDs 157, 158
Check 283
Close editor 35
Commissioning 20
Cone 27
Cone 1 232
Cone 2 232
CSA 20
Current output 66, 164, 289
Current suppression 122
Cylinder pressure 28, 30, 54, 134, 222, 223, 275, 276

D

Digital input 44, 165
Digital output 165
Digital outputs 87, 125
Disposal 11
Distance static 29
Double cone 1 240

Double cone 2 248
Dynamic pressure 30, 162, 220

E

Eccentricity
 Minimum / Maximum 201
 peak-to-peak 198
ESD 15

F

Front view 17
Function generator 283

G

Gap voltage
 Alarm limits 84
Global flags 124

H

hot-swappable 20
Housing expansion
 Add / Sub 277

I

Input 37
Installation 20
Intersection point 52, 135, 257
Interval band by frequency analysis
 Limit 80
Interval band by orders 123, 127
Interval band by orders analysis 63

K

Key
 Mechanical requirements 216
 Sensor adjustment 218

L

Limit multiplier 122
Limit suppression 122
Linearization 43

M

Maintenance 293
Measurement 47
Measurement application 16, 26

N

Network 25
New 31
New Configuration 25
Not 1st order 129
Not 1st order analysis
 Alarm limits 84

O

Online command
 Speed 153
 Static and dynamic measurements 152
Online view
 Details
 Measure result OK 135
 Operation mode 135
 Speed 140
 Static and dynamic measurements 118
Order analysis 62
Overload 156
Overview 35

P

Peak and phase
 Limit 76
Peak and Phase
 Online View
 Details 133
Peakvue 79
PeakVue 62, 171
PR9376
 Load resistor 40
Print configuration 33

R

Relative shaft vibration
 low frequency 30
 Smax 226
 Smax Peak-to-Peak 229
Reload 32
Reset to factory default 32
Ribbon command bar 31
Rod drop
 Average Mode 189, 190
 Triggered Mode 189
Rod Drop

Rod Drop (*continued*)
 Average Mode 29
 Triggered Mode 29, 193, 195
Rod gap 189
Rod Gap 29, 196
Rotational direction 100
Run-up / run-down 66, 171

S

Save & Send 32
Sensor raw signal 167
Shaft position
 Min / Max 267
Shaft position, single channel 182
Show History/Draft 34
Side view 17
Simulation mode 290
Speed
 Current output 103
 Digital input 88
 Digital output 104
 Measurement 90
 Mechanical requirements 208
 Redundant 29
 Rotational direction 280
 Sensor adjustment 212
Speed difference trigger 111
Speed range suppression 122
Static pressure sensor 163

T

Tandem 27, 256
Tandem II 256
Technical data 295
Technical support 10
Trigger threshold 97, 167, 215, 219

V

Vibration - low frequency with order analysis 30, 224
VR sensor 212, 218, 219
VR Sensor, Channel OK supervision 163

W

Workspace 23

Z

Zener barrier 40

Emerson
12001 Technology Drive
Eden Prairie, MN 55344 USA
T 1(952)828-3000
www.Emerson.com

Emerson
835 Innovation Drive
Knoxville, TN 37932 USA
T +1 865-675-2400
F +1 865-218-1401
www.Emerson.com

Emerson
Jöbkesweg 3
48599 Gronau
Germany
T +49 2562 709 0
F +49 2562 709 401
www.Emerson.com/ams

©2024, Emerson. All rights reserved.

The contents of this publication are presented for informational purposes only, and while diligent efforts were made to ensure their accuracy, they are not to be construed as warranties or guarantees, express or implied, regarding the products or services described herein or their use or applicability. All sales are governed by our terms and conditions, which are available on request. We reserve the right to modify or improve the designs or specifications of our products at any time without notice.

The Emerson logo is a trademark and service mark of Emerson Electric Co. The AMS logo is a mark of one of the Emerson family of companies. All other marks are the property of their respective owners.

