



ROXAR SAND MONITOR

ROXAR PIG DETECTOR

The Roxar Acoustic products portfolio
Non-intrusive monitoring & measurement



Emerson Process Management and its portfolio of Roxar Flow Measurement solutions is a pioneer in the development of acoustic non-intrusive technology for PIG detection and sand monitoring. Starting in the early 1990's, we have built up a wealth of expertise which is demonstrated by the following:

.....

- » Thousands of non-intrusive acoustic devices installed across the world, often in some of the most challenging environments both onshore and offshore.
- » A commitment to providing support and service through our Global Service organisation ensuring that our flow measurement operate at peak performance.
- » Continuous product development and improvement.
- » Complete and seamless integration with our leading topside, subsea and downhole meters and instrumentation – a one stop supplier.

Roxar Sand monitor (SAM)

The Roxar Sand monitor (SAM) is a non-intrusive sand monitoring system that identifies in real-time sand production in any water, oil, gas or multiphase flow lines for onshore and offshore locations. It offers a cost effective means for operators to optimise production by enabling the determination of maximum sand-free rates or maximum acceptable sand production rates.

Decreasing production costs is becoming more and more important as reservoirs are maturing. As a result, sand production needs to be closely measured and monitored in order to avoid serious damages. If not properly controlled, sand production can have a damaging impact on the integrity of the production system. One consequence of this optimisation can be increased sand production which again can lead to serious damage to production equipment, such as valves, chokes and pipe bends. If not controlled, high sand production can have a damaging impact on the integrity of the production system.

Sand monitors are valuable for production system integrity. They:

- » Allow the monitoring and prediction of erosion in process equipment in order to ensure safe production and reduced down time.
- » Enable optimised production through the determination of Maximum Sand Free Rate (MSFR) or Acceptable Sand Rates (ASR).
- » Allow for improved production processes in order to prevent pipelines or separators filling with sand.
- » Enable the monitoring of sand screen integrity.

The Roxar Sand monitor is an acoustic type device. Benefits include:

- » Real-time measurement of sand production in any water, oil, gas or multiphase flow line for onshore and offshore locations.
- » The quantification of sand accumulating in the system by calculating grams per second passing through. This supports Acceptable Sand Rates (ASR), with onsite sand calibration measured against actual conditions in grams per second.
- » The ability to detect sand noise without calibration.
- » No mechanical moving parts resulting in low maintenance.
- » It is a compact and low weight device.
- » The non-intrusive design benefits include:
 - No wetted parts
 - No pipe pressure drop
 - Easy to install
 - No shutdown required for installation
 - And easy to retrofit for existing installations



The building blocks behind the Roxar Sand monitor

The Roxar Sand monitor design consists of several parts;

- » A monitor consisting of a transducer and housing clamped on to the pipe.
- » The basic safe area electronics consisting of a Calculation & Interface Unit (CIU) and a safety barrier.
- » SW - software

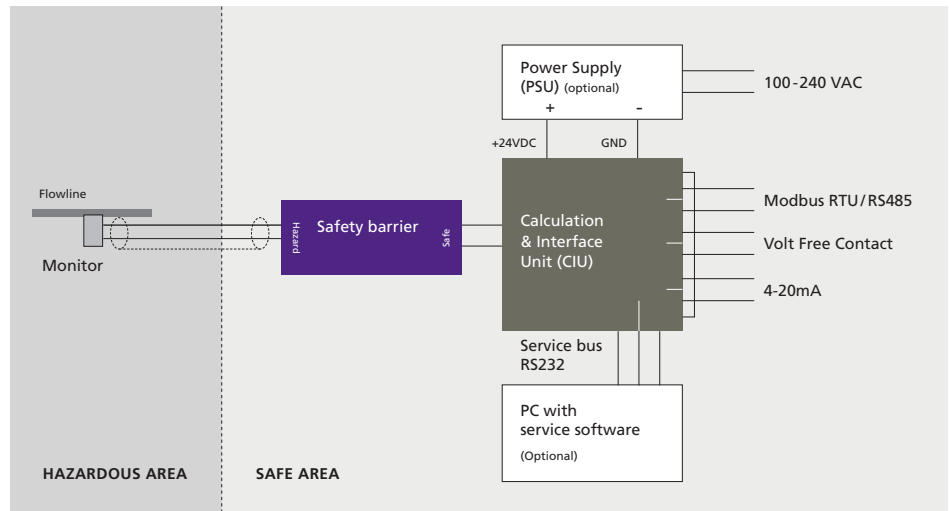

SAM working principle

Roxar Sand monitors are non-intrusive devices that utilise the acoustic noise generated by sand particles to derive a sand production measurement. It utilises the fact that the sand, while transported with the flow, impacts the pipe wall due to inertia in pipe bends and creates noise. This noise is then processed and used to identify and calculate real-time sand production in any water, oil, gas or multiphase pipeline flows. The sensor picks up noise that propagates in the pipe wall and converts it to a digital signal that is transmitted on the sensor power cable to the Calculation Interface Unit (CIU) which calculates the sand production rate based on the sensor signal and built-in algorithms. Detector readings for up to 90 days are stored in an internal flash memory based on 10 second average intervals.

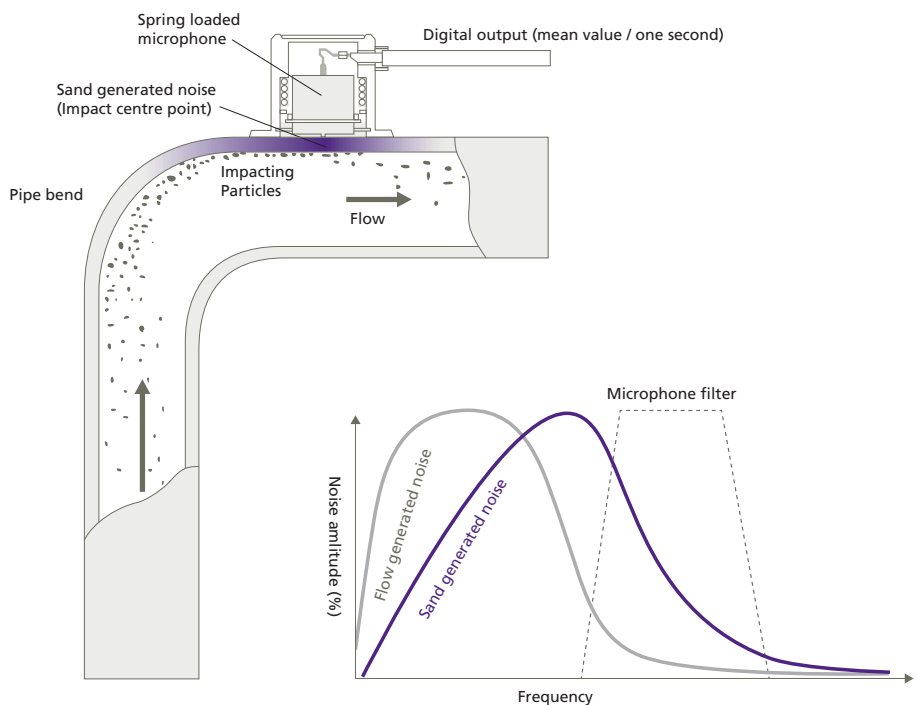

Roxar Pig detector (PDS)

The Roxar Pig detector (PDS) is a non-intrusive, bi-directional unit that detects the high frequency acoustic emissions generated by all types of PIGs as they move through the pipe. The detector is truly passive, with no moving parts or active emission sources.

PIG detectors are valuable for pipeline integrity applications. They:

- » Enable control over the travel of the PIG through the PIG loop.
- » Generate information if the PIG successfully passed problem areas.
- » Enable operators to gain knowledge of the location of large obstacles within the PIG loop.

The Roxar Pig detector is an acoustic type device which has a number of benefits:

- » Any type of PIG can be detected in both directions.
- » It generates accurate timings at which a PIG passes a given point.
- » There are no mechanical moving parts resulting in low maintenance.
- » It provides indications on the amount of pipeline debris pushed ahead by a PIG.
- » It is a compact and low weight device
- » Non-intrusive design benefits include:
 - No wetted parts
 - No pipe pressure drop
 - Easy to install (no tappings or welding required)
 - No shutdown required for installation
- » It is easy to retrofit for existing installations with no need for modifications to the piping or PIG.

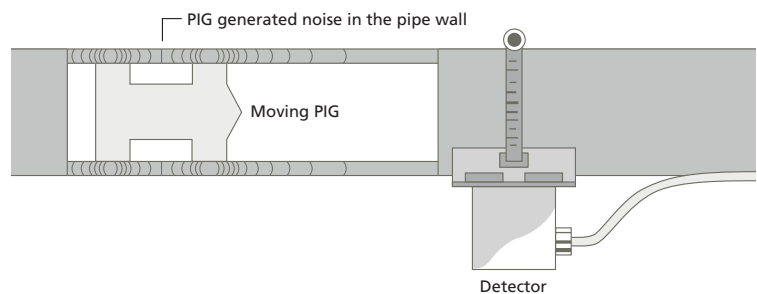
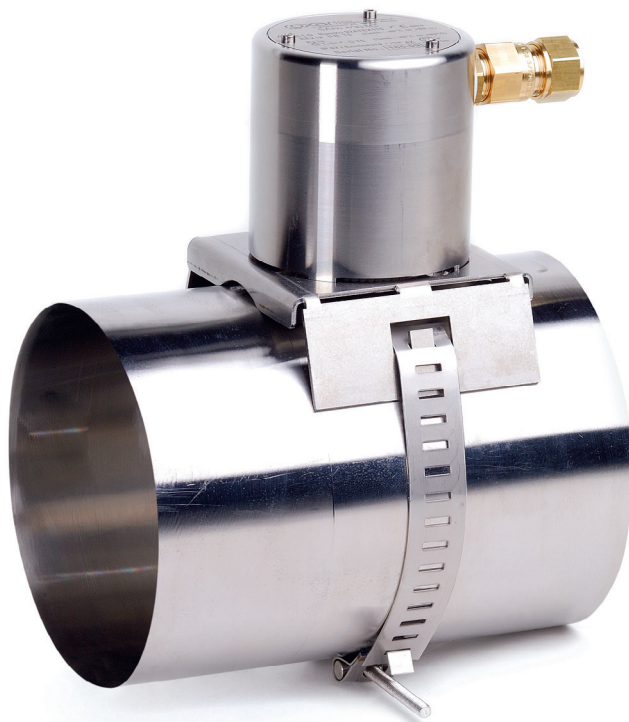

The building blocks behind the Roxar Pig detector

The Roxar Pig detector design consists of several parts;

- » A detector consisting of a transducer and housing clamped on to the pipe.
- » The basic safe area electronics consisting of a Calculation & Interface Unit (CIU) and a safety barrier.
- » Service software.

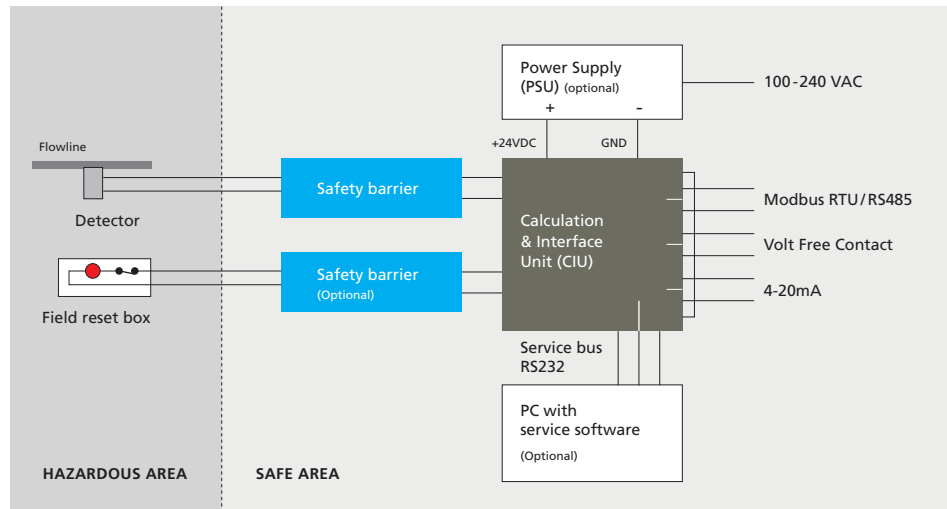

PDS working principle

When a PIG travels through the pipe, the friction between the PIG and the pipe will generate a characteristic noise. This noise contains information that can be interpreted to gain more knowledge on the situation inside the pipe. By designing the Roxar Pig detector around an acoustic emission transducer this noise is detected and can be transformed into valuable information.

PIGs in general generate sufficient noise to allow detection at velocities at a minimum 0.05 m/s depending on PIG material. Noise within the ultrasonic frequency band of the sensor will be largely dominated by that induced by passing PIGs. Contributions from other external sources are negligible which again minimises the risk for spurious and false readings.

The Calculation and Interface Unit (CIU) receives a digitised noise signal from the detector once every second.

- » When a PIG is approaching the detector, the noise generated by the PIG rises above the Average Noise Level (ANL) and when increasing above a defined limit the CIU gives a 'PIG Approach' signal.

- » When the PIG has passed the detector the noise level will drop back to normal level. When the noise level drops below a defined limit the CIU generates a 'PIG Passed' signal.

The defined limits can be set to suit the typical noise level for any type of PIG, as the example in the illustration below demonstrates.

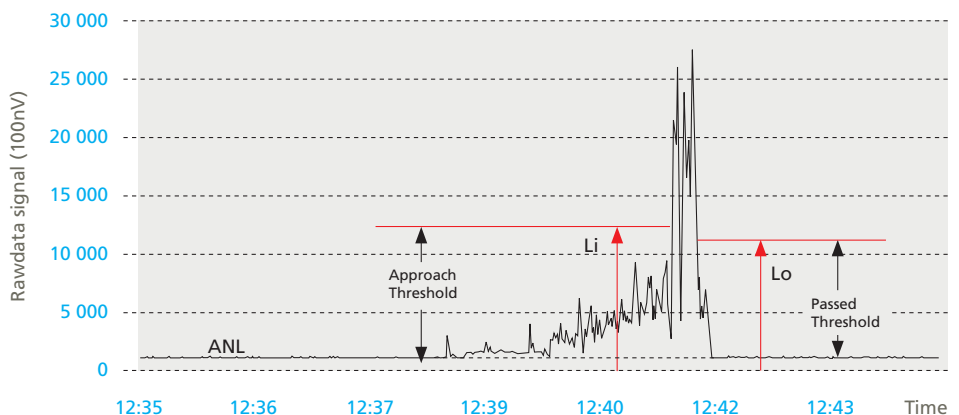

Technical specifications

Common for both models

Operating

- » **Ambient temperature:**
-40 °C to 80 °C
- » **Data storage:**
Up to 90 days based on
10 s averaging interval

Electrical specifications

- » **Detector / monitor supply voltage:**
24 VDC (powered through CIU)
- » **CIU supply voltage:**
24 VDC
- » **Power consumption:**
Power consumption varies between
1.2 to 2.5W depending of which
barrier is used

Mechanical

- » **Detector / monitor dimensions:**
88 mm (OD) x 100 mm
- » **Detector / monitor weight:**
3.0 kg
- » **Ingress protection:**
IP66-67
- » **CIU dimensions:**
23 mm + 6 mm x 99 mm x 113 mm
(WxLxH)
- » **CIU weight:**
0.2 kg
- » **Safety barrier dimensions:**
12.6 mm x 105 mm x 90 mm (WxLxH)

Installation / location

- » **Detector / monitor:**
Fixed on pipe exterior in Ex ia /
Zone 0, 1 or 2
- » **CIU, Safety Barrier, etc:**
DIN-rail mountable in Safe area
or optional in field enclosure

Standard compliance

- » EN 10204 3.1



Roxar Sand monitor

Uncertainty:

+/- 5% (with sand injection calibration).

Repeatability:

The sensors have repeatability better than 1%, meaning that the sensor signal will read the same values with less than 1% deviation for fixed noise reference signals generated by a calibrated noise generator. The reference signals range from zero to maximum sensor reading of 2 mill (100nV).

Flow velocity:

Minimum 1 m/s.

Sand particle detection limit:

In liquid $\geq 25 \mu\text{m}$.

In gas ≥ 15 to $25 \mu\text{m}$.

Depending on flow rate, viscosity etc.

Roxar Pig detector

Uncertainty:

Up to +/- 2 sec. depending on flow regimes and calibration level.

Repeatability:

The sensors have repeatability better than 1%, meaning that the sensor signal will read the same values with less than 1% deviation for fixed noise reference signals generated by a calibrated noise generator. The reference signals range from zero to maximum sensor reading of 2 mill (100nV).

Flow velocity:

Minimum 0.05 m/s
depending on PIG material.

PIG detection limit:

Cleaning PIG (e.g. steel):
minimum 0.05 m/s.

Sealing PIG (e.g. foam):
> 0.5 m/s.

Configuration and service SW

The data from the acoustic sensors can be sent directly from the Calculation Interface Unit (CIU) to the Distributed Control System (DCS) by digital or analogue IO without having to connect to a PC. Another way to configure, extract and analyse information from the sensors is by using the Roxar service software which is part of every delivery of a Roxar Sand monitor or Roxar Pig detector. The CIU software is an .exe file which makes a direct connection from a windows-based computer to the CIU.



Safe area electronics

Calculation & Interface Unit

The Calculation & Interface Unit (CIU) is the data handling module of the acoustic sensor. It receives the information from the detector/monitor and outputs the engineering values. The CIU has several communication interface options, both digital and analogue. Each CIU features 8 LED indicators, showing the present operational status.

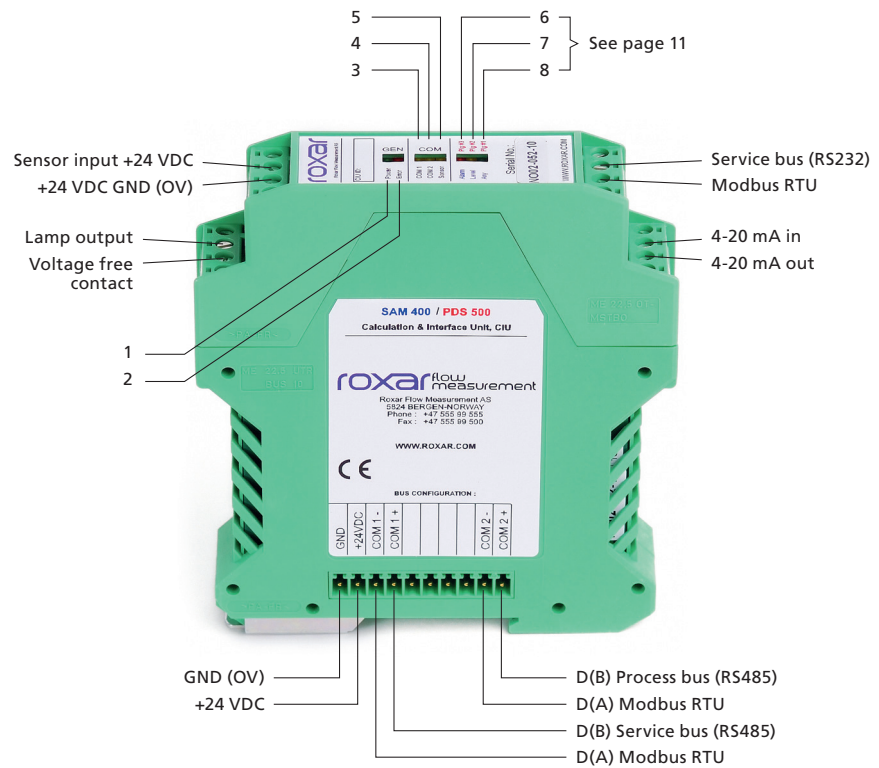

CIU input and output

CIU INPUT	CIU OUTPUTS			
	Lamp output	Voltage free contact	Analogue 4-20mA	Modbus RTU
<p>■ SAM: In order for the Roxar Sand monitor to give out sand rates, input on velocity is needed. This can be done by either connecting the CIU to DCS using the Modbus RTU protocol or an analogue interface using a 4-20 mA current signal.</p> <p>■ PDS: No input required.</p>	<p>■ SAM: Not used for the Roxar Sand monitor.</p> <p>■ PDS: Output which is connected to the Roxar field reset box in order to give indication of PIG passed and reset of such.</p>	<p>■ COMMON: The voltage free contact option is a MOSFET/OptoMOS switch that is normally open or closed (configurable). It operates with a maximum load current of 100 mA. Maximum load voltage across the switch is 350 VAC.</p> <p>■ SAM: The voltage free contact can be configured to indicate sand alarm or technical error.</p> <p>■ PDS: The voltage free contact switch is activated each time a 'PIG Passed' signal is generated. It can be configured to indicate technical errors.</p>	<p>■ COMMON: The Analogue 4-20 mA option is a passive current output, implying that external DC voltage must be applied to the current output terminals of the CIU. An internal D/A converter regulates the current flow through the terminals, according to specified settings.</p> <p>■ SAM: Analogue output for sand rate (g/s) or sensor raw signal [100 nV].</p> <p>■ PDS: The current can either represent the detector raw signal, or a 'PIG passed' signal.</p>	<p>■ COMMON: The CIUs can be addressed directly by the DCS using standard Modbus RTU protocol or a standard serial COM port through an RS485/RS232 converter.</p> <p>The Modbus RTU option is a standard Modbus RTU communication protocol where the CIU is a Modbus slave unit with a unique ID. An RS485 to RS232 converter might be needed in order to interface with a standard serial COM port.</p>

LED configuration

Common for both models

	1 ●	2 ●	3 ●	4 ●	5 ●
	Power	Tecnical error	Com1	Com2	Sensor
LED description	When power (24VDC) is switched on to the module, the 'Power' LED is lit.	When the 'Error' LED is lit, there is an error in the system. This may indicate communication failure (no contact with sensor), flash memory error, or that the program is not running properly.	The 'COM1' LED will flash when data is being received or transmitted on the Modbus RS485 Service bus or on the RS232 configuration port.	The 'COM2' LED will flash when data is being received or transmitted on the Modbus RS485 Process bus.	When communication with the sensor is established, the 'Sensor' LED will flash once every second. After power-up, or if the sensor is connected after start-up of the CIU, it can take up to 10 seconds before the first data packet is received.

Roxar Sand monitor

	6 ●	7 ●	8 ●
	Sand mass exceeded	Sand rate alarm exceeded	Sand production
LED description	When the sand production rises above an alarm level, this register holds the accumulated sand production since this event occurred. If the mass reaches a pre-set value in kg, a sand alarm goes of. If the sand production drops below a pre-set alarm bound limit before this happens, the accumulation is stopped, and if the sand production stays below this level for a given 'time to alarm reset' the accumulator is cleared. The sand mass is given in 0.01 kg.	Sand Alarm.	This register contains the last calculated value for sand production in gram/second. The sand production rate is given in 0.01g/s (i.e. average value since last polling).

Roxar Pig detector

	6 ●	7 ●	8 ●
	PIG no. 3	PIG no. 2	PIG no. 1
	<ul style="list-style-type: none"> » Before the first PIG has passed, none of the LEDs will be lit. » After the passage of the first PIG, only the first (green) LED will be lit. » After the passage of the second PIG, only the second (yellow) LED will be lit. » After the passage of the third PIG, only the third (red) LED will be lit. » After the passage of the fourth PIG, only the first (green) LED will be lit. And so on.... 		

Safety barrier

The detector is usually powered through a Zener barrier. In order to maintain its safety integrity, the sensor cable screening is shunted to IS earth, via the DIN rail on which the barrier is mounted. The sensor cable shield is normally connected to IS-earth. The IS-earth is left floating out in the hazardous area.

The cable armour should be connected to detector housing and connected to Protective Earth (PE) in the safe area. If an intrinsically safe earth (IS earth) is not available on the site, the Zener barrier may be replaced by a galvanic isolated current repeater.

Installation requirements

Common for both models

The detector unit is non-intrusive and can be installed on production pipe work of any diameter between 2" and 48". Note that the Ex classification marking must be visible for inspection also after installation.

The figure to the right shows the assembly and envelope for the different versions available, Standard Temperature (ST) and High Temperature (HT) of a Roxar acoustic sensor. Dependent on specific models of acoustic sensors (PDS or SAM), some special installation requirements may apply – detailed on this page for the different models. Specific General Arrangement (GA) drawings for the different models and versions can be provided upon request. Please contact Emerson/Roxar sales representatives for such inquiries.

Assembly and envelope for the different versions of a the Roxar acoustic sensor. >

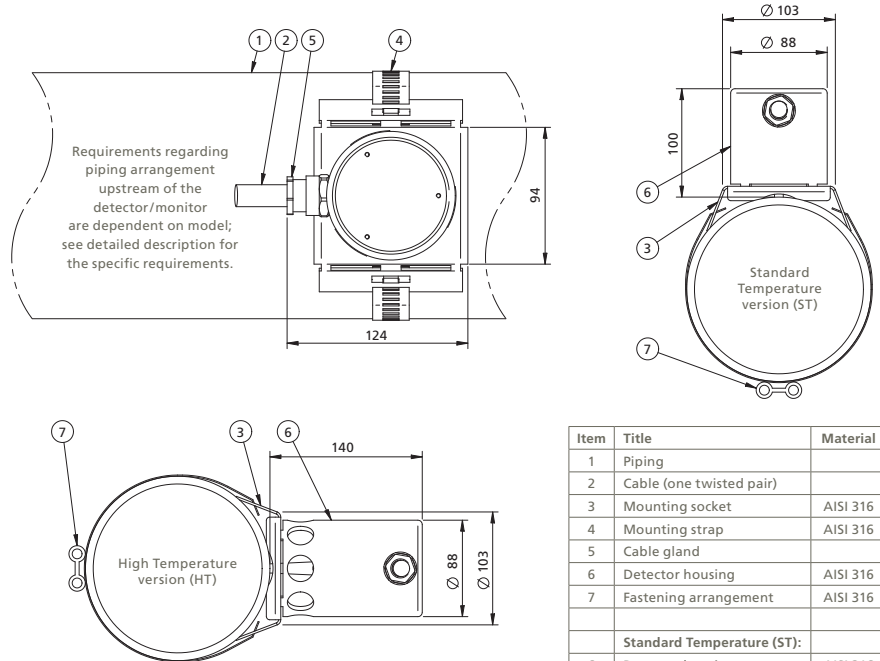

Item	Title	Material
1	Piping	
2	Cable (one twisted pair)	
3	Mounting socket	AISI 316
4	Mounting strap	AISI 316
5	Cable gland	
6	Detector housing	AISI 316
7	Fastening arrangement	AISI 316
Standard Temperature (ST):		
6	Detector housing	AISI 316
High Temperature (HT):		
6	HT Detector housing	AISI 316

Roxar Sand monitor

In order to achieve the best sensitivity the Roxar Sand monitor should be installed downstream from and as close as possible to a 90° bend and not further away than 75 cm. This is because of the need for the pipe geometry and particle inertia work to increase the concentration and force of the particle impact – and thereby the sand response, allowing for high quality measurements.

Care should be taken to avoid installation near known sources of unwanted noise – for example choke valves or cyclonic de-sanding equipment. Excessive levels of unwanted noise may compromise the measurement principle in the worst case scenario.

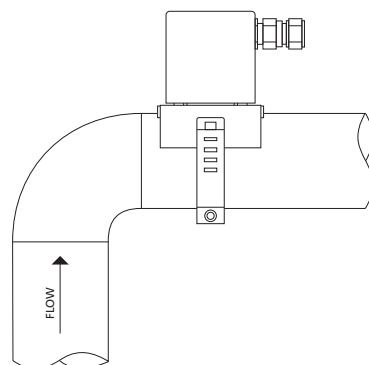

Roxar Pig detector

The Roxar Pig detector is mounted in a straight pipeline section, normally after the PIG launcher and before the PIG receiver. Excessive levels of unwanted noise may in the worst case compromise the measurement principle. Care should be taken to avoid installation near valves or too close to the Pig receiver/launcher.

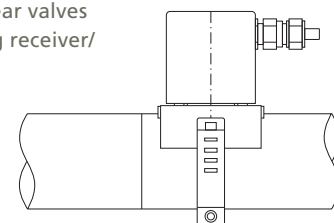

Installation considerations

Common for both models

The Roxar Acoustic sensors come in two different versions – Standard Temperature (ST) and High Temperature (HT). In both cases, certain installation and environmental considerations must be taken into account.



Safe use



Safe use, but not recommended (risk for non-safety-critical sensor damage).



Unsafe use (outside certified temperature envelope).

T_a

Ambient temperature:
The temperature of air or other media in a designated area surrounding the equipment.

T_p

Surface temperature:
of pipe on which equipment is mounted.

Standard Temperature version (ST):

For the Standard Temperature version (ST), there are no requirements as to how the detector is installed on the pipe. The only installation requirement for the Standard Temperature version (ST) is that there is space between the detector housing and pipe insulation. This is to allow the heat to dissipate from the detector and the pipe so that the detector's temperature is kept as low as possible.

	T6	T5	T4		T3	T2
T _a max	T _p max 80 °C	T _p max 95 °C	T _p max 115 °C	T _p max 130 °C	T _p max 195 °C	T _p max 290 °C
40 °C	●	●	●	●	●	●
50 °C	●	●	●	●	●	●
60 °C	●	●	●	●	●	●
70 °C	●	●	●	●	●	●
80 °C	●	●	●	●	●	●

High Temperature version (HT):

The High Temperature version (HT) has an extended waveguide 'nose' in the front end in order to retract the sensor electronics further away from the hot pipe surface. The High Temperature version (HT) of the detector housing is supplied with vent holes in order to provide a more efficient heat evacuation. The high temperature version shall **always** be mounted horizontally on the pipe.

	T6	T5	T4	T3		T2	
T _a max	T _p max 80 °C	T _p max 95 °C	T _p max 130 °C	T _p max 170 °C	T _p max 195 °C	T _p max 240 °C	T _p max 290 °C
40 °C	●	●	●	●	●	●	●
50 °C	●	●	●	●	●	●	●
60 °C	●	●	●	●	●	●	●
70 °C	●	●	●	●	●	●	●
80 °C	●	●	●	●	●	●	●

Model code numbering system

SAM01 - ST - 012 - A - A1 - 01 - 0A - 2 - 02A

1 2 3 4 5 6 7 8 9

1 Base model

Indicates which type and version of the acoustic family of products available:

- SAM01** The Roxar Sand monitor
- PDS01** The Roxar Pig detector

2 Functional properties

Indicates which versions of the sensor that is available:

- ST** Standard Temperature ¹⁾ version (ST);
-40 °C to +115 °C
- HT** High Temperature ¹⁾ version (HT);
-40 °C to +290 °C

3 Size

Indicates which types of mounting fixtures are available:

- 012** Mounting fixtures from 2" to 12" pipe size
- 024** Mounting fixtures from 12" to 24" pipe size
- 036** Mounting fixtures from 24" to 36" pipe size
- 048** Mounting fixtures from 36" to 48" pipe size

Mounting fixtures contains of the following items:

- » Mounting socket
- » Mounting strap
- » Fastening arrangement

4 Main material

Indicates which type of materials available for detector housing:

- A** Stainless steel 31600/03

5 Approvals

Following hazardous area classification is available.

- » ST version: II 1 G Ex ia IIB T4-T6 Ga / Class I Division 1 Gr C, D T4-T6
- » HT version: II 1 G Ex ia IIB T2-T6 Ga / Class I Division 1 Gr C, D T2-T6v

The Roxar Sand monitor and the Roxar Pig detector holds the following Ex certificates:

- A2** 02ATEX110X:
- A3** IECEx NEM 09.0016X
- A4** CSA 1299771 (CSAus)
- A5** INMETRO UL-BR 14.0947X
- A6** EAC RU C-RO.MIO62.B.00827

6 Electro mechanical interface

Indicates which types and versions of electro mechanical interfaces to the detector housing are available:

- 01** Cable gland Tranberg E 805/1/M20 brass
- 02** Adaptor M20/1/2" NPTF incl.
Cable gland Hawke 501/453UNIV
O 1/2" NPT nickel plated
- 03** Cable gland Hawke 501/453UNIV
O M20 nickel plated
- 04** Adaptor M20/1/2" NPTF incl.
Cable gland Hawke 501/453UNIV
O 1/2" NPT SS316
- 05** Cable gland Hawke 501/453UNIV
O M20 SS316

7 Communication interface

Indicates which types of options are available for communication interface; outputs from the CIU:

- 0A** Roxar standard Modbus RTU / Analogue 4-20 mA / Voltage Free Contact

8 Supply voltage

Indicates which types of supply voltage are available:

- 1** 24 VDC

9 Product specific options

Indicates which types of product specific options are available:

- 01A** Zener barrier (IS) with rail kit parts ³⁾
- 02A** Zener barrier (IS) without rail kit parts
- 01B** Galvanic isolator barrier (Non ISE) with rail kit parts ³⁾
- 02B** Galvanic isolator barrier (Non ISE) without rail kit parts

Rail kit consists of the following parts:

- » DIN rail; 316 – 0.5m / CU – 0.2m
- » Terminal blocks
- » Fuse
- » 10 pin connector (Phoenix)
- » Delivery does not incl. wires

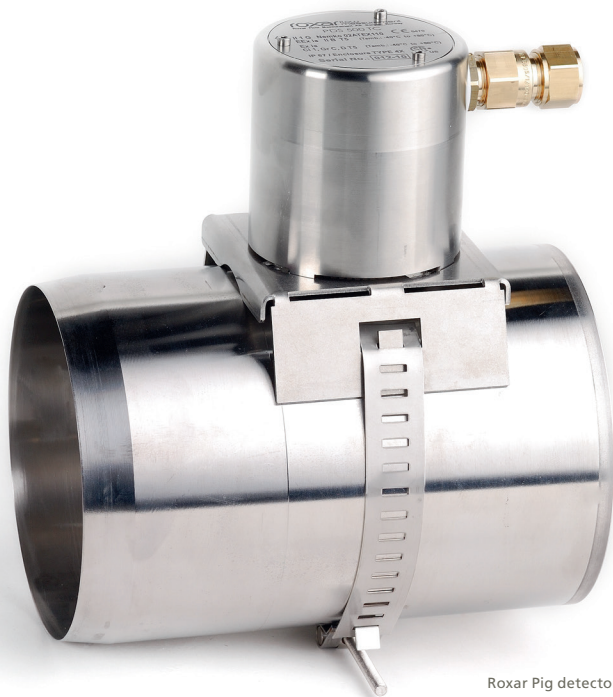

Roxar Pig detector.

- 1)** Temperature is related to Pipe surface temperature and must be seen in relation with ambient temperature.
- 2)** Requires separate power supply unit in order to convert from 100-240 VAC to 24 VDC the input voltage needed for the sensor.
- 3)** To be supplied as loose items.

Additional services or options

In addition to the product described in model codes, Roxar can supply standard additional options, services and spare parts as separate order lines. Options might be mandatory, based on the model codes selected.

Additional deliverables

Indicates which types of additional deliverables options are available:

PSU Power supply unit ⁴⁾

Model: Phoenix MINI.

Input voltage: 100-240 VAC 50/60 HZ.

Output voltage: 24 VDC.

Mounting: DIN-rail mountable.

Location: Safe area or optional field enclosure.

CONV Converter RS232/RS485 ⁵⁾

Model: Phoenix PSM-ME-RS232/RS485-P.

Mounting: DIN-rail mountable.

Location: Safe area or optional field enclosure.

Converter can be supplied in order to allow connection of the RS485 differential signal to a standard serial COM port on a PC.

FRB Field Reset Box for Roxar Pig detector ⁶⁾

Material: 316.

Ingress protection: IP66.

No. of cable entries: 1.

Supply voltage: 24 VDC (supplied through the CIU).

Electro Mechanical interface:

Cable gland as per Item 6 in Model Code.

FRB1: Field reset box – Ex ia

FRB2: Field reset box – Ex de

The box consists of a lamp in series with a reset switch. The lamp will turn on when a 'PIG Passed' signal is generated. The lamp will stay on until the lamp circuit is broken with the reset switch.

TAG Roxar standard customer tag plate ⁷⁾

FC Field cable ⁸⁾

Specifications: BFOU(i) 1x2x0,75

PAINT SH Painting of Sensor Housing

Specifications: NORSOK M501, RAL 7035 (light grey) - available only for Standard Temperature

PAINT FR Painting of Field Reset Box

Specifications: NORSOK M501, RAL 7035 (light grey)

Additional services

FPI Final Production Inspection

This is held in Roxar's premises and includes witness of product testing as described in Roxar's standard FAT procedure and signing of standard FAT report. The Final Product Inspection does not include product training, review of documentation (except the FAT report) or Third Party Inspection costs.

Spare parts

SST Sensor Standard Temperature

SHT Sensor High Temperature

DHST Detector Housing Standard Temperature

DHHT Detector Housing High Temperature

MSA Metal Strap Assembly ⁹⁾

RAILKIT Rail Kit Parts

DS Detector Socket

CGST Coupling Grease Standard Temperature

CGHT Coupling Grease High Temperature

ZB Zener Barrier

GIB Galvanic Isolator Barrier

PSU Power supply unit ⁴⁾

CIU Calculation and Interface Unit (CIU)

CONV Converter RS232/RS485 ⁵⁾

FRB1 Field reset box – Ex ia for Roxar Pig detector

FRB1 Field reset box – Ex de for Roxar Pig detector

Documentation

Indicates which types of documentation options are available:

- STDDOC** Roxar standard documentation package
- MC** Including material certificates ¹¹⁾
- CDF** Including customer defined front pages and drawing frames ^{11) 12)}
- HCXX** Hard Copies- xx- fill in correct number of requested Hard Copies (example 02 for 2 hard copies)

Post delivery service

To get the most out of your equipment, Roxar can provide a full range of post delivery services including:

Class room training

Typically a two day course for a minimum of 4 participants at a Roxar world area service centre.

Installation & commissioning support

To ensure the optimum set up for

equipment performance.

Technical services agreements

Longer term service agreements with regular maintenance, 24/7 helpdesk support, data analysis, spare parts etc. to support ongoing operations and secure long term performance.

For more details and to request a quotation for post delivery services please contact your local sales representative or e-mail gsc.roxar@emerson.com.

- 4) Only applicable if 24VDC voltage input is not available.
- 5) One converter is recommended for more than 1 unit, and for every 8 units.
- 6) Ex de version does not require any safety barrier, while Ex ia require zener barrier. Hazardous area certificates are limited to ATEX and IECEx.
- 7) Plate 60x15x1 mm with 6 mm hole in one end, material: SS316, text size H: 3.5 mm and W: 2.2 mm.
- 8) Requested amount of meter to be added to the code.
- 9) The metal assembly strap is for up to 12" pipe. If the pipe is larger, please add the correct amount of straps.
- 10) Only available as option when STDDOC has been previously supplied.
- 11) Additional deliveries to the Roxar standard documentation package.
- 12) Customer input required as part of PO. Only one review cycle is included for the filled in front pages and drawing frames. No other document review is included.



Roxar Sand Monitor.

Non-standard options

Common for both models



Roxar can facilitate the delivery of other options than the standard ones stated on the previous pages. The selection of either of the options described in this chapter will result in a non-standard delivery and hence will be subjected to cost and delivery time impact. Please contact Emerson/Roxar sales representatives for further details regarding these options.

Installation & support

Roxar Global Service is a worldwide service organisation. Roxar Global Service employs more than 100 service staff across a network of offices in Europe, the Americas, Africa, CIS, Asia, Australia and the Middle East – all with a wide array of industry experience. Safety is always a key focus, as proven by our outstanding track record over the years.

We maintain an Emergency Preparedness Program in order to always be available to support regular as well as non-regular calls from our field personnel.

From installation through to a field's decommissioning, we believe in helping you get maximum value from the technology solutions we deliver and enhancing your customer experience.

In order to secure a smooth and successful start-up, it is recommended that Roxar designated personnel are called out on the final commissioning of the Roxar acoustic sensors. Installation and commissioning of one Roxar Sand detector is estimated to take one day. Installing more than one detector at a time will save some time for logistics and hence reduce the overall time needed.

For further information please contact gsc.roxar@emerson.com.

Ex d / de enclosures

If installation of safe area components in hazardous area is required, Roxar offers both a SS316 and an aluminium Ex d / de explosion proof enclosure for installation in the field.

Coating of equipment

For additional surface protection and increased visibility, the equipment can be coated.

Fieldwatch software

Roxar Fieldwatch is a server-based software that collects, validates and stores all the data from all sand management devices and other Roxar equipment. The operator can access, validate, interpret, and analyse all data from all Roxar meters at the same time. Full sand system status overview enables rapid response and decision making. Configuration and maintenance to all Roxar instruments can be done from one uniform software platform.

Subsea versions

Both the Roxar Pig detector and Roxar Sand monitor are available in subsea versions.

Roxar Sand monitor

The Roxar Sand monitoring system

Emerson believes that a sand monitoring strategy is key to operator's success in managing a well. Numerous technologies are available in the market, but Emerson by its Roxar division is the only company in the world that can offer you both intrusive and non-intrusive types of sand monitoring equipment. Roxar non-intrusive devices like the acoustic technology are known to have instant information about the quantity of sand in operator systems. On the other hand, intrusive devices are known for offering trending capabilities to project how your pipelines will be affected by sand in the future.

The Roxar Sand monitoring solutions portfolio is the most complete package by one vendor in the world today. They include:

- » Intrusive Sand Erosion insertion probes for the long time trending of erosion of the total system.
- » Intrusive Corrosion monitors to measure metal loss in pipeline due to either corrosion or erosion.
- » A Field Signature Method (FSM) to permanently monitor critical areas of a pipe in regards to metal loss due to either corrosion or erosion.
- » Non-intrusive Sand acoustic monitor for real time measurement and adjustment.
- » Fieldwatch – the software platform to analyse, trend and interpret your data from all sand management devices.

Portable systems

As an option, Roxar also offers a portable Sand monitor system, providing flexibility for well testing and other applications where it is a benefit to move the monitor to different locations in the field.

4-phase flow rates

The Roxar Sand monitor can be integrated with the Roxar Multiphase meter. The Roxar Multiphase meter measures in real-time the different parameters related to multiphase flow. When the two meters are combined, an accurate measurement of water, gas, oil and sand flow rates can be given, prior to separation. The consequence being that this solution can be installed directly on top of the well in order to provide early live measurements which enable quick response times when flow is changing for the worse.

Sand calibration

As an additional option, Roxar offers to fine-tune the Roxar Sand monitor by performing a sand calibration. The purpose of the sand calibration is to remove the unwanted noise that affects the sensors' measurements. In order for this to be possible a controlled sand injection system must be present in the vicinity of the Roxar Sand monitor. The calibration can be done, due to the fact that zero reading of the detector is of a constant value, regardless of flow velocity, temperature, pressure or other pipeline variables. Flow noise and particle noise, on the other hand, both increase as the flow velocity increases. During calibration, the monitor is told exactly how these parameters are related in order to filter away unwanted noise and enabling better sand measurement.

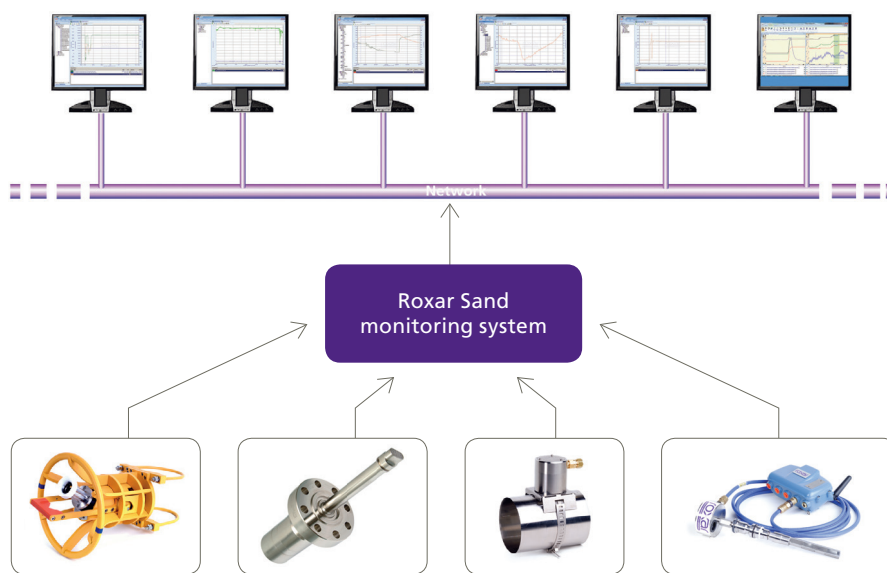

WWW.ROXAR.COM | INFO.ROXAR@EMERSON.COM |

