

# Thai Oil's Refinery Cogeneration Site Saves \$1M Using AMS™ Suite: Real-Time Optimizer



## RESULTS

- \$1M savings from energy reduction
- Equipment selection advice
- Project payback of less than 3 months

## APPLICATION

Cogeneration facility supplying steam and power to supplement the internal generation on the refinery, to adjacent facilities and to the national grid.

## CUSTOMER

Thai Oil Public Co. Ltd. - Sriracha Refinery, Thailand.

## CHALLENGE

Thai Oil is the owner and operator of a 220 TBD refinery at Sriracha. It is also a part-owner of an adjacent 115 MW co-generation 3-on-1 combined cycle facility. The refinery produces a proportion of the internal demands for steam and electricity. The co-generation plant meets the balance of the refinery demands, while also producing surplus electricity to the Electricity Generating Authority of Thailand, and also steam and electricity to affiliates Thai Carbon Product, Thai Lube Base and Thai Paraxylene.

The refinery and adjacent facilities require steam at a number of pressure levels. Steam is provided by the co-generation heat-recovery boilers and five dual gas / oil fired conventional boilers within the refinery. This is distributed to the users via a series of inter-connected headers. There are also several refinery process units that provide fixed quantities of steam via heat-recovery units.

Steam is let-down between pressure levels using steam turbine generators and by desuperheaters. Electricity is also generated by three co-generation natural gas fired turbines and by two package diesel generators in the refinery.

As part of Thai Oil's automation vision to deliver underlying performance improvements, cost savings and reliable operation, an optimization system was identified to also meet the following objectives:

- Reduce overall energy consumption.
- Obtain the most cost-effective method of meeting the site's power and steam demands.



*“Selecting Emerson’s optimization technology has proven to be of great importance to us and is instrumental in saving us around \$1 million each year.”*

**Ampon Singsakda,**  
Technical Coordinator

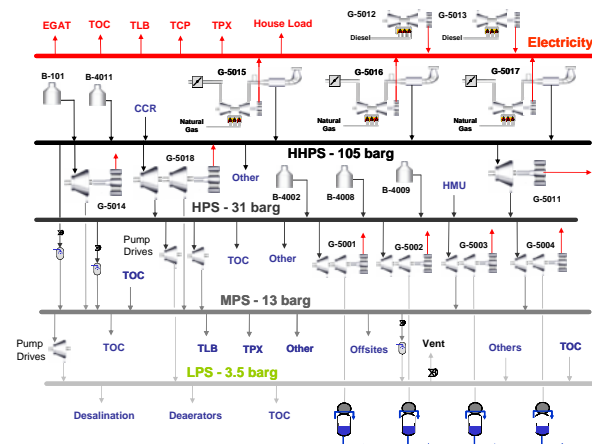

Thai Oil Utilities complex.



For more information:  
[www.assetweb.com](http://www.assetweb.com)



### SOLUTION

AMS Suite: Real-Time Optimizer was selected to provide a continuous open-loop real-time optimization system to improve the economic operation, minimize utility operating costs, and to optimize distribution of load and supply under current operating constraints.

The AMS Optimizer delivers operational benefits by balancing steam generation and turbine operation to minimize overall fuel consumption.

The AMS Optimizer provides operational recommendations for the optimal setpoints and constraints which include recommendations on equipment changes. Optimal setpoints for operator implementation include:

- Gas turbine power
- Steam turbine throttle and extraction flows
- Boiler steam loads

Key constraints include:

- Steam and electricity demands
- Heat recovery boiler limits
- Boiler fuel limits
- Steam turbine generation limits

The cost function minimized by the AMS Optimizer includes:

- Natural gas fired by the gas turbines
- Fuel gas fired by the boilers
- Fuel oil fired by the boilers
- Boiler feed water for the steam generation equipment

The AMS Optimizer also informs the operators when it is appropriate to start-up additional electrical generation equipment, or switch between steam and electric machinery drives when there is excess steam generation across the headers.

### RESOURCES

#### Presentation (Emerson Exchange)

[www.PMO.Assetweb.com/casestudies/thaioil.ppt](http://www.PMO.Assetweb.com/casestudies/thaioil.ppt)

#### Emerson Process Management Asset Optimization Division

North America:

12603 SW Freeway, Suite 400  
Stafford, TX 77477  
T +1 281-207-2800  
F +1 281-207-2814

Europe:

Startforth Road,  
Riverside Park  
Middlesbrough, TS2 1PT, U.K.  
T +44 1642 773000  
F +44 1642 773077

[www.assetweb.com/pmo](http://www.assetweb.com/pmo)



AMS Suite: Real-Time Optimizer powers PlantWeb by optimizing operations in real-time, based on changing plant conditions and business constraints.

***“We are delighted that Emerson has provided a system that fulfils our requirement to predict optimum operating conditions for the overall utility plant operations.”***

**Ampon Singsakda,**  
Technical Coordinator

©2006, Emerson Process Management.

The contents of this publication are presented for informational purposes only, and while every effort has been made to ensure their accuracy, they are not to be construed as warranties or guarantees, express or implied, regarding the products or services described herein or their use or applicability. All sales are governed by our terms and conditions, which are available on request. We reserve the right to modify or improve the designs or specifications of our products at any time without notice.

All rights reserved. AMS is a mark of one of the Emerson Process Management group of companies. The Emerson logo is a trademark and service mark of Emerson Electric Company. All other marks are the property of their respective owners.

