

# Config600™ Configuration Software User Manual

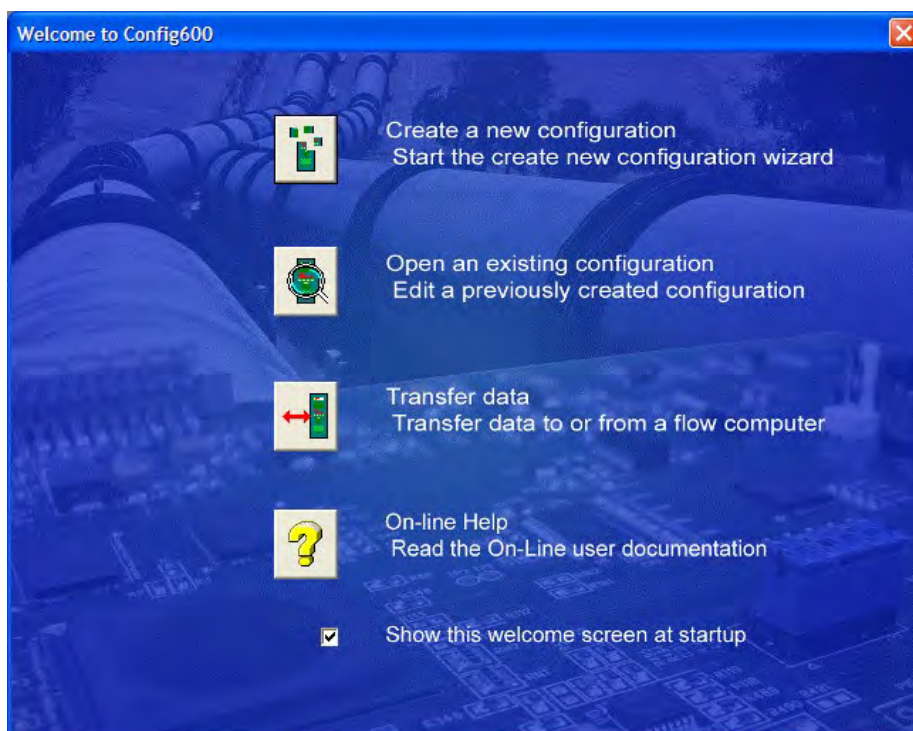



## System Training

A well-trained workforce is critical to the success of your operation. Knowing how to correctly install, configure, program, calibrate, and trouble-shoot your Emerson equipment provides your engineers and technicians with the skills and confidence to optimize your investment. Energy and Transportation Solutions offers a variety of ways for your personnel to acquire essential system expertise. Our full-time professional instructors can conduct classroom training at several of our corporate offices, at your site, or even at your regional Emerson office. You can also receive the same quality training via our live, interactive Emerson Virtual Classroom and save on travel costs. For our complete schedule and further information, contact the Energy and Transportation Solutions Training Department at 800-338-8158 or e-mail us at [Education@Emerson.com](mailto:Education@Emerson.com).



# Contents

<b>Chapter 1 – Introduction</b>	<b>1-1</b>
1.1 Configuration Updates.....	1-1
1.2 Scope of Manual .....	1-2
1.3 Software Basics .....	1-3
1.4 Installing Config600 .....	1-5
1.5 Accessing Config600.....	1-8
1.6 Activating Config600.....	1-9
1.7 Additional Technical Information .....	1-11
<b>Chapter 2 – PCSetup Editor</b>	<b>2-1</b>
2.1 Create a New Configuration .....	2-1
2.1.1 Name the Configuration (Step 1 of 6).....	2-2
2.1.2 Select Measurement Units (Step 2 of 6).....	2-3
2.1.3 Specify Modules (Step 3 of 6).....	2-4
2.1.4 Specify Stations (Step 4 of 6).....	2-5
2.1.5 Define Streams (Step 5 of 6).....	2-8
2.1.6 Select Communications (Step 6 of 6).....	2-16
2.2 Analyse a Configuration (System Graphic).....	2-17
2.3 Open an Existing Configuration (PCSetup Editor).....	2-23
2.3.1 Navigating the PCSetup Editor .....	2-25
2.3.2 The Icon Bar.....	2-27
2.4 The Menu Bar.....	2-27
2.5 Managing Configurations.....	2-29
2.5.1 Save a Configuration .....	2-29
2.5.2 Regenerate a Configuration.....	2-29
2.6 Display Editor.....	2-30
2.7 Config Transfer Utility.....	2-30
2.8 Config Organiser Utility.....	2-30
<b>Chapter 3 – System Setup</b>	<b>3-1</b>
3.1 Versions.....	3-2
3.2 Units.....	3-3
3.2.1 Supported Units .....	3-4
3.3 Reports.....	3-6
3.3.1 General Reports.....	3-7
3.3.2 Base Time Reports.....	3-8
3.3.3 Default Reports.....	3-9
3.3.4 Report History.....	3-9
3.3.5 Adding a General Report to a Configuration.....	3-9
3.3.6 User Reports .....	3-11
3.3.7 Adding a Base Time Report to a Configuration.....	3-11
3.3.8 Managing Configuration Reports.....	3-13
3.4 Totalisations .....	3-14
3.5 Time.....	3-16
<b>Chapter 4 – I/O and Comms Configuration</b>	<b>4-1</b>
4.1 Discrete (Digital) Inputs (DI) .....	4-2
4.1.1 Assigning Discrete (Digital) Inputs.....	4-2
4.1.2 Editing Discrete (Digital) Inputs.....	4-3
4.1.3 Adding Discrete (Digital) Inputs.....	4-4
4.2 Discrete (Digital) Outputs (DO) .....	4-5
4.2.1 Assigning Discrete (Digital) Outputs .....	4-5

4.3	Analog Inputs (AI).....	4-6
4.3.1	Assigning Analog Inputs (AI).....	4-6
4.3.2	Editing Analog Inputs (AI).....	4-7
4.3.3	Adding a New I/O Point.....	4-15
4.4	Analog Outputs (AO).....	4-15
4.4.1	Editing Analog Outputs.....	4-15
4.5	Density Inputs.....	4-17
4.5.1	Assigning Density Input.....	4-17
4.5.2	Editing Density Inputs.....	4-18
4.6	Turbine Inputs.....	4-19
4.6.1	Assigning Turbine Inputs.....	4-19
4.6.2	Editing Turbine Inputs.....	4-21
4.7	Pulse Outputs.....	4-21
4.7.1	Assigning Pulse Outputs.....	4-22
4.8	HART Modules.....	4-22
4.8.1	Editing HART Settings.....	4-23
4.9	PID Loop Settings.....	4-23
4.9.1	Assigning PID Loops.....	4-24
4.9.2	Proportional Plus Integral and Derivative Action.....	4-28
4.10	Communications Port.....	4-30
4.10.1	Editing a Communications Task.....	4-30
4.10.2	Setting Up Peer-to-peer Options.....	4-35

**Chapter 5 – Station Configuration** **5-1**

---

5.1	Station Flowrate Limits.....	5-2
5.2	Station Averaging Temperature & Pressure.....	5-4
5.3	Station Secondary Units Setup.....	5-6
5.4	Station Flow Switching.....	5-8
5.5	Station Gas Composition.....	5-10
5.6	Sampling.....	5-15
5.7	Prover Configuration Screens.....	5-18
5.7.1	Flow Balance Setup.....	5-18
5.7.2	Prover – Ball (Bi-Directional) (Liquid Only).....	5-20
5.7.3	Prover – Compact (Liquid Only).....	5-32
5.7.4	Prover – Master Meter (Gas and Liquid).....	5-45

**Chapter 6 – Stream Configuration** **6-1**

---

6.1	Initial Configurations.....	6-2
6.2	Common Stream Settings.....	6-4
6.2.1	General Settings.....	6-4
6.2.2	Flowrate.....	6-5
6.2.3	Stream Secondary Units Setup.....	6-7
6.2.4	Stream Flow Switching Setup.....	6-10
6.2.5	Gas Component Flow Weighted Averaging (GC FWA).....	6-11
6.2.6	Density Measurement.....	6-13
6.2.7	Block Valves.....	6-16
6.2.8	Time & Flow Weighted Averaging Methods.....	6-18
6.3	Gas – Coriolis.....	6-22
6.3.1	AGA8 (Compressibility).....	6-23
6.3.2	Gas CV (ISO6976 or GPA2172/ASTM D3588).....	6-25
6.3.3	Gas CV (AGA5).....	6-30
6.3.4	Stream Gas Composition.....	6-31
6.3.5	Gas Properties.....	6-36
6.3.6	Ethylene.....	6-39
6.3.7	Linearisation.....	6-40
6.3.8	Sampling.....	6-42
6.3.9	Coriolis.....	6-45
6.3.10	Local Units.....	6-49
6.4	Gas – DP.....	6-50
6.4.1	Downstream/Upstream Correction.....	6-50

6.4.2	Pipe Correction.....	6-53
6.4.3	AGA8 (Compressibility).....	6-56
6.4.4	ISO5167 (Mass Flowrate).....	6-59
6.4.5	ISOTR9464.....	6-62
6.4.6	V-Cone (Mass Flowrate).....	6-64
6.4.7	Annubar (Mass Flowrate).....	6-66
6.4.8	Pure Gas Air.....	6-68
6.4.9	Gas CV (ISO6976 or GPA2172/ASTM D3588).....	6-69
6.4.10	SGERG (Compressibility).....	6-74
6.4.11	NX19 (Compressibility).....	6-77
6.4.12	PTZ (Compressibility).....	6-78
6.4.13	AGA3 (Volume or Mass Flowrate).....	6-80
6.4.14	Stream Gas Composition.....	6-82
6.4.15	Z Steam (Compressibility).....	6-86
6.4.16	GOST CV.....	6-88
6.4.17	GOST Flow.....	6-89
6.4.18	Gas Properties.....	6-92
6.4.19	DP Cell Input Conditioning.....	6-95
6.5	Gas – Turbine.....	6-112
6.5.1	AGA8 (Compressibility).....	6-112
6.5.2	Gas CV (ISO6976 or GPA2172/ASTM D3588).....	6-115
6.5.3	AGA7 (Gross Volume Flowrate).....	6-119
6.5.4	Stream Gas Composition.....	6-122
6.5.5	Gas Properties.....	6-126
6.5.6	Local Units.....	6-129
6.5.7	Linearisation.....	6-129
6.5.8	Sampling.....	6-132
6.6	Gas – Ultrasonic.....	6-135
6.6.1	AGA8 (Compressibility).....	6-136
6.6.2	Gas CV (ISO6976 or GPA2172/ASTM D3588).....	6-138
6.6.3	AGA7 (Gross Volume Flowrate).....	6-143
6.6.4	Stream Gas Composition (Gas Ultrasonic).....	6-145
6.6.5	Gas Properties (Gas Ultrasonic).....	6-149
6.6.6	Local Units.....	6-152
6.6.7	Linearisation.....	6-153
6.6.8	Sampling.....	6-155
6.6.9	Ultrasonic Flow Setup.....	6-158
6.6.10	Ultrasonic Control.....	6-162
6.6.11	QSonc Interface.....	6-163
6.6.12	SICK Control.....	6-164
6.7	Liquid – Coriolis.....	6-167
6.7.1	Local Units.....	6-167
6.7.2	Linearisation.....	6-168
6.7.3	Sampling.....	6-171
6.7.4	Observed Density Correction.....	6-173
6.7.5	Standard Density Correction.....	6-182
6.7.6	Base Sediment and Water (BSW).....	6-188
6.7.7	Coriolis.....	6-189
6.8	Liquid – Turbine.....	6-192
6.8.1	Local Units.....	6-192
6.8.2	Linearisation.....	6-193
6.8.3	Sampling.....	6-196
6.8.4	Observed Density Correction.....	6-199
6.8.5	Standard Density Correction.....	6-207
6.8.6	Base Sediment and Water (BSW).....	6-213
6.9	Liquid - Ultrasonic.....	6-215
6.9.1	Local Units.....	6-215
6.9.2	Sampling.....	6-216
6.9.3	Linearisation.....	6-219
6.9.4	Observed Density Correction.....	6-222
6.9.5	Standard Density Correction.....	6-230
6.9.6	Base Sediment and Water (BSW).....	6-236
6.9.7	Daniel Liquid Ultrasonic.....	6-238

6.10	Modes of Operation .....	6-241
6.10.1	Density Failure Modes.....	6-242

**Chapter 7 – Advanced Setup Configuration 7-1**

---

7.1	Conversions/Constants.....	7-1
7.1.1	Editing Conversions/Constants.....	7-1
7.2	Totals Descriptions .....	7-2
7.2.1	Editing Totals Descriptors.....	7-3
7.3	Alarms.....	7-3
7.3.1	Editing Alarms .....	7-4
7.3.2	Alarm and Event Descriptions .....	7-6
7.4	Security.....	7-14
7.4.1	Editing Security.....	7-14
7.4.2	Editing/Deleting Passwords.....	7-16
7.4.3	Data Item Security.....	7-17
7.4.4	PCSetup Editor Login.....	7-19
7.5	Displays/Webserver.....	7-20
7.5.1	Editing Displays/Webserver .....	7-21
7.6	Calc Explorer.....	7-22
7.6.1	Calc Explorer Options .....	7-23
7.6.2	Adding an Item.....	7-24
7.6.3	Adding All Inputs.....	7-26
7.6.4	Adding All Outputs.....	7-27
7.6.5	Deleting Items.....	7-28
7.6.6	Saving as Bitmaps.....	7-29

**Chapter 8 – System Editor 8-1**

---

8.1	Accessing the System Editor.....	8-2
8.2	The S600+ Database .....	8-3
8.2.1	Objects .....	8-4
8.2.2	Tables.....	8-5
8.3	Navigating the System Editor.....	8-5
8.3.1	Finding Objects.....	8-6
8.3.2	The System Editor Icon Bar .....	8-6
8.3.3	Special Edit.....	8-7
8.3.4	Edit Dialog.....	8-8
8.3.5	Asterisks/No Asterisks.....	8-9
8.4	General Guidelines .....	8-10

**Chapter 9 – Config Transfer 9-1**

---

9.1	Connecting to the S600+ .....	9-2
9.1.1	Connecting via Serial Cable.....	9-2
9.1.2	Connecting via TCP/IP .....	9-2
9.1.3	Enabling the PC Setup Link .....	9-2
9.1.4	Checksum Security.....	9-3
9.2	Accessing Config Transfer .....	9-3
9.3	Communications Settings for Transfer .....	9-4
9.3.1	Setting Communication Parameters .....	9-4
9.4	Send Configuration.....	9-6
9.4.1	Sending a Configuration.....	9-6
9.4.2	Manually Adding a Configuration File to be Transferred.....	9-7
9.5	Receive Configuration.....	9-8
9.5.1	Receiving a Configuration.....	9-8
9.6	Log Transfers.....	9-9
9.6.1	Logging a Transfer .....	9-9
9.7	CFX Licensing.....	9-10
9.7.1	Transferring a License.....	9-10
9.7.2	Removing a License .....	9-12



<b>Chapter 10 – Remote Front Panel</b>	<b>10-1</b>
10.1 Configuring Your PC without a Native Serial Comm Port.....	10-1
10.1.1 Changing the Port on Your USB Communications Port.....	10-2
10.2 Configuring Your PC with a Native Serial Comm Port.....	10-3
10.3 Configuring the S600+ to Use the Remote Front Panel.....	10-4
10.4 Accessing the Remote Front Panel.....	10-7
10.4.1 Remote Front Panel Startup Menu.....	10-7
10.4.2 Disabling the Remote Front Panel.....	10-8
10.4.3 Restoring the Remote Front Panel.....	10-9
<b>Chapter 11 – Remote Archive Uploader</b>	<b>11-1</b>
11.1 Accessing the Remote Archive Uploader.....	11-2
11.2 Automatic Archive Polling .....	11-2
11.2.1 Configure Automatic Polling .....	11-2
11.2.2 Add or Edit an Automatic Poll.....	11-4
11.2.3 Enable Automatic Polling.....	11-6
11.3 Manual Archive Polling .....	11-6
11.3.1 Configuring Config600 Communications .....	11-7
11.3.2 Reload Tree .....	11-8
11.3.3 Upload All Reports / Upload New Reports .....	11-10
11.4 Viewing Reports.....	11-11
11.4.1 Report Archive.....	11-11
11.5 Saving .....	11-12
11.5.1 Directory Settings (File Locations).....	11-12
11.5.2 File Settings .....	11-13
11.5.3 Save As.....	11-14
11.5.4 Folder Formats .....	11-15
11.5.5 Data Integrity .....	11-17
11.6 Printing the Report.....	11-18
11.6.1 Print.....	11-18
11.6.2 Print Preview.....	11-18
11.6.3 Print Setup .....	11-19
11.7 Abort Transfer.....	11-20
<b>Chapter 12 – Report Editor</b>	<b>12-1</b>
12.1 Accessing the Report Editor.....	12-2
12.1.1 Via PCSetup.....	12-2
12.1.2 Via Report Editor.....	12-3
12.1.3 Report Names .....	12-5
12.2 Using the Report Editor.....	12-6
12.2.1 Adding a Data Point.....	12-7
12.2.2 Editing a Data Point.....	12-9
12.2.3 Adding Report Lines .....	12-9
12.2.4 Deleting Report Lines.....	12-10
<b>Chapter 13 – Display Editor</b>	<b>13-1</b>
13.1 Accessing the Display Editor.....	13-1
13.2 Navigating the Display Editor.....	13-2
13.3 Editing the Display Editor.....	13-3
13.3.1 Insert Menu.....	13-5
13.3.2 Insert/Append Page.....	13-5
13.3.3 Edit Line .....	13-5
13.3.4 Translate.....	13-7
13.3.5 Save.....	13-8
13.3.6 Menu/Page Clipboard .....	13-8

13.4	Regenerating Displays .....	13-8
------	-----------------------------	------

**Chapter 14 – Modbus Editor** **14-1**

---

14.1	Supported Function Codes.....	14-1
14.2	Accessing the Modbus Editor .....	14-2
14.3	Using the Modbus Editor.....	14-2
14.4	Map Properties.....	14-3
14.4.1	Insert a Data Point.....	14-5
14.4.2	Quick Insert.....	14-6
14.4.3	Insert Special.....	14-6
14.4.4	Insert Special.....	14-7
14.4.5	Delete a Data Point.....	14-8
14.4.6	Edit Modbus Format .....	14-8
14.4.7	Insert a Message.....	14-10
14.4.8	Insert a Slave.....	14-12
14.5	Regenerating Maps.....	14-13

**Chapter 15 – LogiCalc Editor** **15-1**

---

15.1	Accessing the LogiCalc Editor .....	15-2
15.1.1	LogiCalc Tips.....	15-4
15.1.2	Starting a LogiCalc .....	15-5
15.2	Creating a LogiCalc .....	15-5
15.2.1	Variables.....	15-6
15.2.2	LogiCalc Loops.....	15-7
15.2.3	LogiCalc Constants.....	15-8
15.2.4	Connecting to Data Items .....	15-9
15.2.5	If/Then/Endif .....	15-11
15.2.6	Special Functions.....	15-12
15.2.7	Saving and Compiling a LogiCalc.....	15-13
15.2.8	Running a LogiCalc in Simulation Mode.....	15-14
15.3	Installing a LogiCalc on the S600+ .....	15-15
15.3.1	Remotely Debugging a LogiCalc.....	15-16
15.4	LogiCalc Examples .....	15-16
15.4.1	Perform PTZ Calculations.....	15-17
15.4.2	Convert Temperature Units.....	15-18
15.4.3	Convert Density Units to Kgm3.....	15-18
15.4.4	Convert Density Units from Kgm3.....	15-19
15.4.5	Perform PTZ Calculations and Convert Units.....	15-20
15.4.6	Perform PTZ Calculations on All Streams.....	15-22
15.5	LogiCalc Lanuage Specifications.....	15-23
15.5.1	LogiCalc Statements.....	15-23
15.5.2	Built-In Functions .....	15-26
15.5.3	Alarms.....	15-28

**Appendix A – Glossary** **A-1**

---

**Appendix B – Proving** **B-1**

---

B.1	Bi-Directional (Ball) Prover – Liquid Only .....	B-2
B.1.1	Inputs/Outputs .....	B-3
B.1.2	Communications .....	B-3
B.1.3	Pulse Measurement.....	B-4
B.1.4	Sphere Switch Interface .....	B-5
B.1.5	Valve Interface.....	B-10
B.1.6	Prove Sequence and Control .....	B-11
B.1.7	Prover Run Control Stages .....	B-22
B.1.8	Prove/Stream Data.....	B-31
B.1.9	Prove Reports.....	B-32

B.1.10	Proving Calculations .....	B-34
B.2	Compact Prover – Liquid Only .....	B-42
B.2.1	Inputs/Outputs .....	B-43
B.2.2	Communications .....	B-43
B.2.3	Pulse Measurement.....	B-44
B.2.4	Proving Control Signal Timing .....	B-45
B.2.5	Prove Sequence and Control .....	B-46
B.2.6	Prover Run Control Stages .....	B-56
B.2.7	Run Stage Abort Index.....	B-62
B.2.8	Run Stage Calculation Index.....	B-63
B.2.9	Prove/Stream Data.....	B-63
B.2.10	Prove Reports.....	B-65
B.2.11	Proving Calculations .....	B-66
B.3	Master Meter Prover – Gas and Liquid.....	B-75
B.3.1	Master Meter/Stream combinations.....	B-77
B.3.2	Inputs/Outputs .....	B-78
B.3.3	Communications .....	B-78
B.3.4	Pulse Measurement.....	B-78
B.3.5	Prove Sequence and Control .....	B-79
B.3.6	Prover Run Control Stages .....	B-88
B.3.7	Prove/Stream Data.....	B-94
B.3.8	Prove Reports.....	B-95
B.3.9	Proving Calculations .....	B-97

**Appendix C – Batching** **C-1**

C.1	Batching Overview.....	C-2
C.1.1	Product Table.....	C-2
C.1.2	Station Batch Setup.....	C-8
C.1.3	Product Interface Detection.....	C-15
C.1.4	Slops Handling Examples.....	C-18
C.2	Batch Sequence and Control.....	C-19
C.2.1	Batch Sequence Stages.....	C-20
C.2.2	Retrospective Batch Totals .....	C-29
C.2.3	Batch Alarms .....	C-30
C.2.4	Batch Ticket .....	C-30
C.3	Batch Recalculation .....	C-32
C.3.1	Displays.....	C-32
C.3.2	Batch Ticket .....	C-36
C.3.3	Recalculating Batches.....	C-38
C.4	Flow Switching.....	C-47
C.4.1	Station Flow Switching Setup.....	C-47
C.4.2	Stream Flow Switching Setup.....	C-49
C.4.3	Flow Switching Algorithms.....	C-50
C.4.4	Alarms.....	C-53
C.5	Batch Stack.....	C-53
C.5.1	Configuring the Batch Stack Through the PCSetup Editor.....	C-54
C.5.2	Configuring the Batch Stack with the System Editor.....	C-56
C.5.3	Configuring the Batch Stack through the Front Panel Display .....	C-58
C.5.4	Slot Edit Commands (Front Panel Display).....	C-59
C.5.5	Configuring the Batch Stack from the Webserver.....	C-64
C.5.6	Slot Edit Commands (Webserver).....	C-65
C.6	Basic Batching Setup .....	C-69

**Appendix D – Field Calibration** **D-1**

D.1	Analogue Input Calibration.....	D-1
D.1.1	Calibration Control Requirements .....	D-2
D.1.2	Linear Two-point ADC Device Calibration.....	D-3
D.1.3	Non-linear Three-point Curve-fit ADC Device Calibration.....	D-6
D.1.4	Non-linear Three-point Curve Calibration Control Mechanism.....	D-7
D.1.5	Offset PRT Device Calibration.....	D-8

D.1.6	Linear Two-point Device PRT Calibration.....	D-8
D.1.7	Non-linear Three-point Curve-Fit PRT Device Calibration.....	D-9
D.2	Analogue Output Calibration.....	D-10
D.2.1	Calibration Control Requirements.....	D-10
D.2.2	DAC Device Calibration.....	D-11

**Appendix E – S600+ Database Objects and Fields E-1**

---

E.1	Database Objects.....	E-2
E.1.1	ADC.....	E-2
E.1.2	ALARM.....	E-3
E.1.3	ALARMHIST.....	E-3
E.1.4	ARRTXT.....	E-3
E.1.5	CALCALMITEM.....	E-4
E.1.6	CALCTAB.....	E-5
E.1.7	CONFTAB.....	E-6
E.1.8	CUMTOT.....	E-6
E.1.9	DACOUT.....	E-6
E.1.10	DIGIO.....	E-6
E.1.11	DOSETUP.....	E-7
E.1.12	DPCELL.....	E-7
E.1.13	EVENTHIST.....	E-8
E.1.14	FREQT.....	E-8
E.1.15	HART.....	E-8
E.1.16	HARTTAB.....	E-10
E.1.17	IOASSIGN.....	E-10
E.1.18	KPINT.....	E-10
E.1.19	KPINTARR.....	E-10
E.1.20	KPREAL.....	E-12
E.1.21	KPREALARR.....	E-12
E.1.22	KPSTRING.....	E-13
E.1.23	LOG.....	E-13
E.1.24	MULTI.....	E-14
E.1.25	PID.....	E-14
E.1.26	PIP.....	E-14
E.1.27	POP.....	E-14
E.1.28	PRDTOT.....	E-14
E.1.29	PRT.....	E-15
E.1.30	PRV_CTL.....	E-16
E.1.31	REP00 – REP39.....	E-17
E.1.32	SECURITY.....	E-17
E.1.33	SYSOBJ.....	E-17
E.1.34	TASK.....	E-17
E.1.35	TOTTAB.....	E-17
E.2	Database Fields.....	E-18
E.2.1	Alarm Text Tables.....	E-19
E.2.2	Batching/Totalisation.....	E-19
E.2.3	DIGIO Setup Table.....	E-19
E.2.4	DP Stack Type.....	E-19
E.2.5	DP Live/Check Mode Selection.....	E-19
E.2.6	DP Cut Off Mode.....	E-19
E.2.7	Event History Type.....	E-19
E.2.8	HART Poll Format.....	E-20
E.2.9	HART Master Mode.....	E-20
E.2.10	I/O (P144) PID Type.....	E-20
E.2.11	Prover (P154) Dual Chronometry Switch Pair.....	E-20
E.2.12	Prover (P154) Type.....	E-21
E.2.13	Password Tables.....	E-21
E.2.14	Truth Tables.....	E-21
E.2.15	Turbine Meter Setup Tables.....	E-21
E.3	Mode Tables.....	E-21
E.3.1	ADC/PRT/HART Modes (MODE TAB PLANTI/O).....	E-21

E.3.2	CALC/ALM Auto Switch Modes .....	E-22
E.3.3	CALC/ALM modes (MODE TAB CALC) .....	E-22
E.3.4	Density Transducer Modes (MODE TAB DENS IP).....	E-22
E.3.5	DP Modes (MODE TAB DP STACK).....	E-22
E.3.6	HART Modes (MODE TAB PLANTI/O) .....	E-23

**Appendix F – Peer-to-Peer Link Communications** **F-1**

F.1	Peer-to-Peer Link Input Functionality .....	F-1
F.2	Enabling the Peer-to-Peer Link .....	F-3
F.2.1	Configuring the Peer-to-Peer Link .....	F-4
F.3	Critical Data.....	F-9
F.3.1	Passing an Object from the Duty to the Standby S600+.....	F-14
F.3.2	Period Object Transfer.....	F-16
F.4	Automatic Failover.....	F-17
F.4.1	Configuring the S600+ for Automatic Failover.....	F-19
F.5	External / Custom Failover Modes.....	F-25
F.6	Displays .....	F-26
F.6.1	Control Displays.....	F-26
F.6.2	Feed-back Displays .....	F-27
F.6.3	Option Displays.....	F-28
F.7	Downloading and Verifying the Peer to Peer Link .....	F-28

**Appendix G – Firewall** **G-1**

G.1	Rules File.....	G-1
G.1.1	*Filter Keyword .....	G-2
G.1.2	Default Policies .....	G-2
G.1.3	User Defined Chains.....	G-2
G.2	Adding Rules to the Chain.....	G-3
G.2.1	Applying a Rule to a Range of IPs.....	G-3
G.2.2	Inverting a Rule.....	G-3
G.2.3	After Checking the Rules .....	G-3
G.2.4	Committing the Rules.....	G-3
G.3	Operational Behaviour.....	G-3

**Appendix H – CFX Reporting** **H-1**

H.1	Adding CFX Report Functionality to a Configuration File.....	H-1
H.2	Enabling CFX at the Stream Level.....	H-3
H.3	Changing CFX Settings from Config600.....	H-4
H.4	Regenerating the CFX Report Template.....	H-5
H.5	Generating a CFX Report from the Web Browser .....	H-5
H.6	Understanding the CFX File Structure.....	H-8

**Appendix I – Network Printing** **I-1**

I.1	Overview.....	I-1
I.1.1	Supported Printers.....	I-2
I.1.2	Supported Paper Sizes .....	I-2
I.2	Configuring Printers from PCSetup.....	I-2
I.3	Configuring Printers from the S600+.....	I-4
I.3.1	Configuring at Runtime.....	I-4
I.3.2	Printer Options.....	I-4

I.4	Printing Retries.....	I-5
I.5	Editing Report Line Lengths .....	I-5
I.6	Network Printing Alarms .....	I-8

**Appendix J – Sampling** **J-1**

---

J.1	Overview.....	J-1
J.2	Input / Outputs .....	J-1
J.2.1	Sampler Output.....	J-2
J.2.2	Sampler Can Select Output.....	J-2
J.3	Sampling Options .....	J-2
J.3.1	Sampler Method.....	J-2
J.3.2	Sampler Mode .....	J-3
J.3.3	Can Fill Indicator.....	J-4
J.3.4	Auto Disable.....	J-4
J.3.5	Auto Restart .....	J-4
J.4	Sampling Sequence.....	J-5
J.5	Sampling Alarms .....	J-10
J.6	Sampling Displays .....	J-11
J.7	Sampling – System Editor.....	J-13

**Appendix K – Gas Composition** **K-1**

---

K.1	Station/Stream Combinations .....	K-2
K.2	Gas Composition Modes.....	K-4
K.2.1	CHROMAT Mode.....	K-4
K.2.2	KEYPAD Mode .....	K-4
K.2.3	DOWNLOAD Mode.....	K-5
K.2.4	USER Mode .....	K-6
K.2.5	Mode Selection.....	K-6
K.3	Chromat Telemetry .....	K-8
K.3.1	Telemetry Inputs .....	K-8
K.3.2	Telemetry Outputs.....	K-9
K.3.3	EURO Stages.....	K-11
K.3.4	USA Stages.....	K-16
K.3.5	Siemens Stages.....	K-20
K.3.6	Generic Stages .....	K-21
K.4	Composition Processing .....	K-23
K.4.1	Component Ordering .....	K-23
K.4.2	High/Low Limits.....	K-25
K.4.3	Deviation.....	K-26
K.4.4	Normalisation.....	K-26
K.4.5	Additional .....	K-27
K.4.6	Splits.....	K-27
K.4.7	Critical Alarms .....	K-30
K.4.8	Non-Critical Alarms.....	K-30
K.4.9	Timeouts.....	K-31
K.5	Auxiliary Data.....	K-31
K.5.1	EURO (2551 / 2350 EURO) + USA (2251 / 2350 USA).....	K-32
K.5.2	SIEMENS + GENERIC.....	K-32
K.5.3	Station to Stream Copying .....	K-32
K.6	Dual GC Handling.....	K-33
K.6.1	CHROMAT A.....	K-33
K.6.2	CHROMAT B.....	K-33
K.6.3	CHROMAT AUTO .....	K-34
K.7	Displays.....	K-34
K.7.1	Default Displays .....	K-34
K.8	Alarms.....	K-35
K.8.1	Default Alarms .....	K-35
K.9	Reports.....	K-36
K.9.1	CHR TELEMETRY .....	K-36
K.9.2	CHR D/LOAD .....	K-38

K.10	Modbus Maps.....	K-40
K.11	User Customisation – How Tos.....	K-41
K.11.1	SIEMENS GC.....	K-42
K.11.2	GENERIC GC.....	K-42
K.11.3	Multi-dropped GCs .....	K-42
K.11.4	Mole Select – Keypad Fail Switchback.....	K-42
K.11.5	Download Flag.....	K-42

**Index**

**Index-1**

---

*[This page is intentionally left blank.]*



# Chapter 1 – Introduction

## In This Chapter

1.1	Configuration Updates .....	1-1
1.2	Scope of Manual.....	1-2
1.3	Software Basics.....	1-3
1.4	Installing Config600.....	1-5
1.5	Accessing Config600.....	1-8
1.6	Activating Config600 .....	1-9
1.7	Additional Technical Information.....	1-11

This manual describes how to use the Config600™ configuration software suite of editors (referred to as “Config600”) to configure the FloBoss™ S600+ Flow Computer (referred to as “S600+”). The software runs on a personal computer (PC) running Microsoft® Windows® 7 Professional (32-bit or 64-bit) or Windows® 10 (32-bit or 64-bit). Refer to the technical specification *Config600™ Configuration Software (Config600)*.

This manual discusses configuring S600+ options, including calculations; input/output (I/O); communications; Proportional, Integral, and Derivative (PID) loops; stations; streams; displays; Modbus maps; LogiCalc programming; and reports.

Use this manual in conjunction with the *FloBoss S600+ Flow Manager Instruction Manual* (part D301150X412).

---

**⚠ Caution** When implementing control using this product, observe best industry practices as suggested by applicable and appropriate environmental, health, and safety organizations.

---

This chapter details the structure of this manual and provides an overview of the Config600 software.

## 1.1 Configuration Updates

The S600+ CPU module has also been enhanced and now contains an upgraded version of firmware. You can download existing configurations from earlier versions of Config600 without change. However, if you use the latest version of Config600 to modify an old configuration, the configuration file upgrades and will work **only** with version 8 and above. That means you can no longer use old versions of Config600 to edit that configuration.

When you open an older configuration in the current version of Config600, the following dialog box displays:



Figure 1-1. Config Upgrade dialog

If you click **OK** to upgrade, you cannot then use this configuration on an S600+ which has firmware less than version 06.07. If you need to use this configuration on older S600+ flow computers, click Close (X) to end this process. We suggest you then re-create this configuration using the most current version of Config600 or create a copy of the old configuration.

## 1.2 Scope of Manual

This manual contains the following chapters:

Chapter	Description
Chapter 1 Introduction	Defines the scope of the document, provides an overview of the Config600 software, and details how to install the software.
Chapter 2 PCSetup Editor	Describes the PCSetup Editor interface, the configuration generator, how to save configurations, and the System Graphic utility.
Chapter 3 System Setup Configuration	Describes the System Setup screens (Versions, Units, Reports, and Totalisation) in the PCSetup Editor, and the configuration wizard.
Chapter 4 I/O and Comms Configuration	Describes the Input/Output (I/O) assignment screens, the PID loop settings screens, and the communication task settings screen in the PCSetup Editor.
Chapter 5 Station Configuration	Describes the Station Settings screens in the PCSetup Editor.
Chapter 6 Stream Configuration	Describes the Stream Settings screens in the PCSetup Editor.
Chapter 7 Advanced Setup Configuration	Describes the Advanced Setup screens (Conversions, Totals Descriptors, Alarms, Security, and Displays/Webserver) in the PCSetup Editor and the Calc Explorer utility.
Chapter 8 System Editor	Describes the advanced configuration editor, the System Editor (which includes Station Mapping). <b>Note:</b> This utility is available <b>only</b> with Config600 Pro.
Chapter 9 Config Transfer	Describes the configuration transfer utility. Use this utility to send new or modified files to the S600+ over either a dedicated serial port or a TCP/IP connection. Config Transfer also enables you to retrieve configuration files from the host PC to the S600+.

**PRO**

Chapter	Description
Chapter 10 Remote Front Panel	Describes how to set up the Remote Front Panel to configure your S600+ and perform certain functions from your PC. <b>Note:</b> The Remote Front Panel requires part S600+EXT (the licence key for Remote Front Panel)
Chapter 11 Remote Archive Uploader	Describes how to automatically upload all reports and alarms in the historical archive in the S600+ flow computer.
Chapter 12 Report Editor	Describes the report format editor.
Chapter 13 Display Editor	Describes the editor you use to customize the front panel and webserver displays of the S600+.
Chapter 14 Modbus Editor	Describes the Modbus map editor.
Chapter 15 LogiCalc Editor	Describes the editing tool for the LogiCalc programming language. <b>Note:</b> This tool is available <b>only</b> with Config600 Pro.
Appendix A: Glossary	Provides definitions of acronyms and terms.
Appendix B: Proving	Provides a description of the three proving methods Config600 supports: bi-directional (and uni-directional), compact, and master meter.
Appendix C: Batching	Describes the type of batch method you can use for non-permanent flows or “start-stop” batching.
Appendix D: Field Calibration	Describes hardware calibration you perform after production to determine the relationship between analogue converter counts and current.
Appendix E: S600+ Database Objects and Fields	Provides an alphabetic listing of the database objects you can access through the Connect Wizard (which is part of the Report Editor, Modbus Editor, LogiCalc Editor, Display Editor, and System Editor).
Appendix F: Peer-to-Peer Communications	Describes the bi-directional communications link between the A and B computers allowing the duty S600+ to update the standby S600+ with any operator changes made locally at the duty S600+ keypad or through the supervisory system.
Appendix G: Firewall	Provides information detailing the S600+ firewall to keep out unwanted incoming network connections.
Appendix H: CFX	Provides information on creating Common File eXchange (CFX) reports.
Appendix I: Network Printing	Provides information on network printing options for the S600+.
Index	Provides an alphabetic listing of items and topics contained in this manual.

PRO

## 1.3 Software Basics

Config600 software is a Microsoft Windows-based suite of tools that enables you to configure and communicate with the S600+ using a host PC. The software has three versions:

- **Config600 Lite**, which provides a basic set of tools designed to help you modify existing configurations.
- **Config600 Lite Plus**, which adds a tool to create configurations to Config600 Lite.

- **Config600 Pro**, which provides a more powerful set of tools to help you create and manage configurations.

---

**Note:** If you are new to the S600+, review *Chapter 2, PCSetup Editor*. This section describes the basic steps involved in configuring your S600+ for your application. You can then use the PCSetup Editor (available in Config600 Pro) to edit existing configurations.

---

Table 1-1 compares the tools available in each version.

Table 1-1. Config600 Tools

Tool	Config600 Lite	Config600 Lite Plus	Config600 Pro
PCSetup	X	X	X
Config Transfer	X	X	X
Report Editor	X	X	X
Modbus Editor	X	X	X
Display Editor	X	X	X
LogiCalc Editor			X
System Editor			X
Config Generator		X	X
Remote Archive Uploader <sup>1</sup>	X	X	X
Remote Front Panel <sup>1</sup>	X	X	X
Version History	X	X	X

<sup>1</sup>Remote Archive Uploader and Remote Front Panel are extended functions of Config600 which you must license separately to use. Contact your sales representative for further information.

Using the PCSetup Editor in Config600, you define the initial S600+ configuration settings for gas, liquid, or prover applications. These initial configurations include system setup, Input/Output (I/O) setup, stations, and streams. You save these configurations to a configuration folder on the host PC. Using the Config Transfer utility, you send (“download”) the configuration to the S600+ through a serial or Ethernet communications port. The download also stores the sent configuration permanently in the S600+’s memory.

With Config600 Pro software, you can:

- Use the **Config Generator Wizard** to create new configurations.
- Use the **Config Transfer** utility to send or receive the configuration to the S600+ through a serial or Ethernet communications port. The exchange also stores the send configuration permanently in the S600+’s memory.
- Use the **Display Editor** to configure front panel/webserver displays.
- Use the **LogiCalc Editor** to configure LogiCalc applications.
- Use the **Modbus Editor** to configure Modbus communications.
- Use the **PCSetup Editor** to define the initial S600+ configuration settings for gas, liquid, or prover applications. These initial configurations include system setup, Input/Output setup, stations, and streams. You save these configurations to a configuration directory on the host PC.

- Use the **Remote Archive Uploader** to automatically upload all reports in the historical archive in the S600+ and manually upload other types of files.
- Use the **Remote Front Panel** to configure the S600+ to run from the PC.
- Use the **Report Editor** to generate system reports.
- Use the **System Editor** to configure the S600+ database.
- Use the **Version History** text file to view a change history document that explains changes and updates to the Config600 and S600+.

---

**Note:** To get help on a specific screen, press **F1** or click Help. You can also modify the size of the Config600 editor window by clicking and dragging the lower right corner of the window. When configuration panes have scroll bars, modify the window size to make sure you can view all the configuration settings.

---

## 1.4 Installing Config600

---

Remote Automation Solutions distributes Config600 software either on a CD-ROM or as a downloadable zipped file. You can install Config600 software on a PC running Microsoft® Windows® 7 Professional (32-bit or 64-bit) or Windows® 10 (32-bit or 64-bit).

---

**Note:** Refer to the product data sheets *S600+* and *Config600* (available <https://www.emerson.com/en-us/catalog/emerson-floboss-s600>) for complete product requirements and specifications.

---

To install Config600:

1. Place the Config600 installation CD-ROM in your PC's CD or DVD drive. The installation should begin automatically.
2. If the CD-ROM does not run automatically, click **Start > Run**. When the Run dialog box opens, click **Browse**, navigate to the CD-ROM drive, and select setup.exe. Click **Open**. The system completes the file location. Click **OK** in the Run dialog box.

---

**Note:** If you are using a zipped executable file, download the file to a temporary location (the installation program installs the file in (C:\Users\<<USERNAME>>\Config600 3.4). Unzip the file and click **setup.exe**.

---

The Installation Wizard screen displays, and determines whether you have previously installed Config600.

3. If this is a new installation, the Config600 Welcome screen displays, followed by a License Agreement screen.

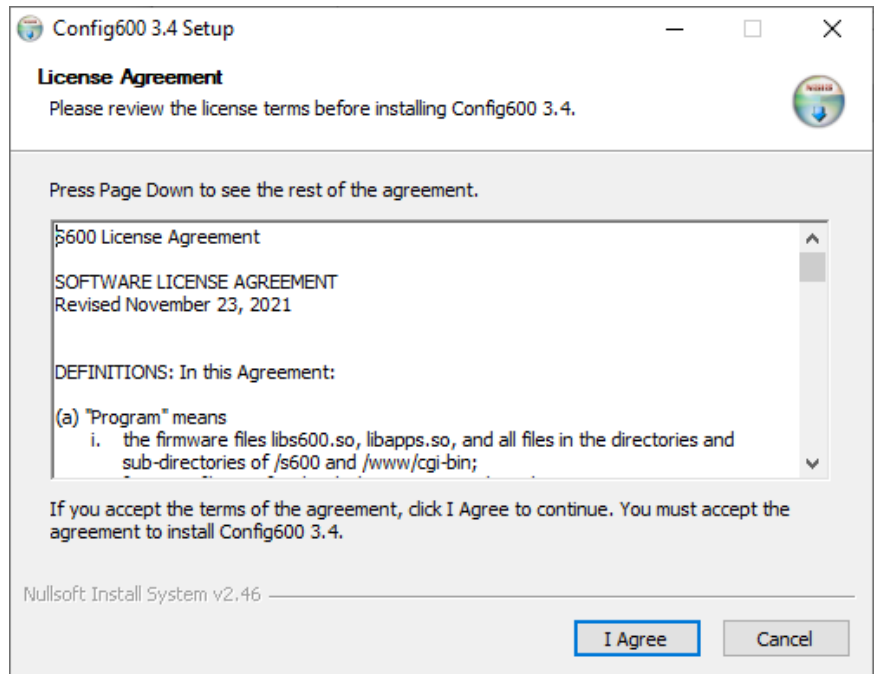

Figure 1-2. License Agreement

4. Review the license agreement and click **I Agree** to continue. A Choose Components screen displays.

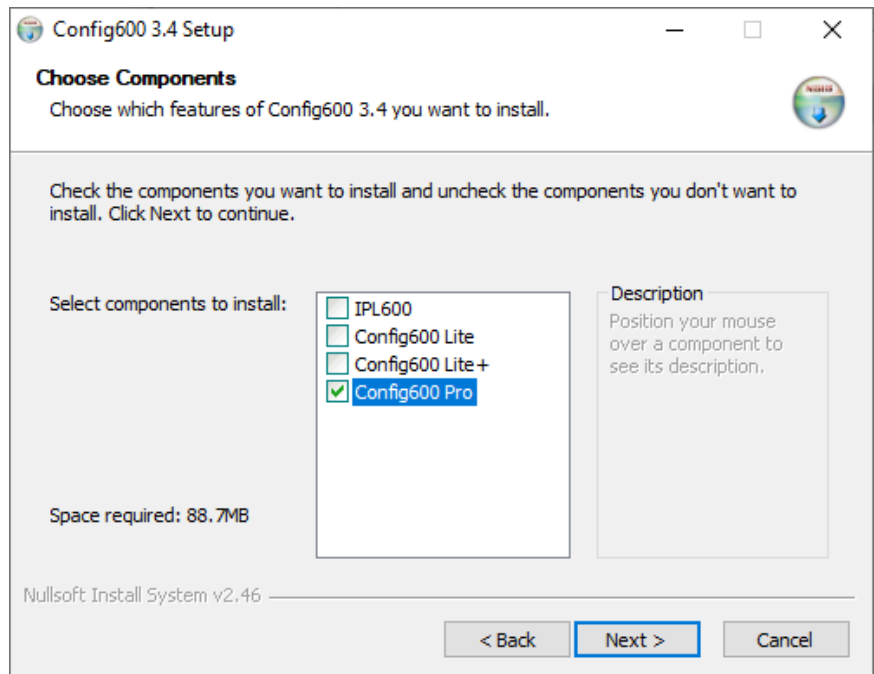

Figure 1-3. Choose Components

---

**Note:** Config600 Pro activation codes/licences are issued **only** to those who successfully complete the RA901 Advanced Config600 training course.

---

5. Select to install the version of Config600 you have purchased and click **Next**. The installation wizard identifies the default destination folder (C:\Users\<<USERNAME>>\Config600 3.4).

**Note:** Attendance at the Config600 Pro training class is **required** to use Config600 Pro.

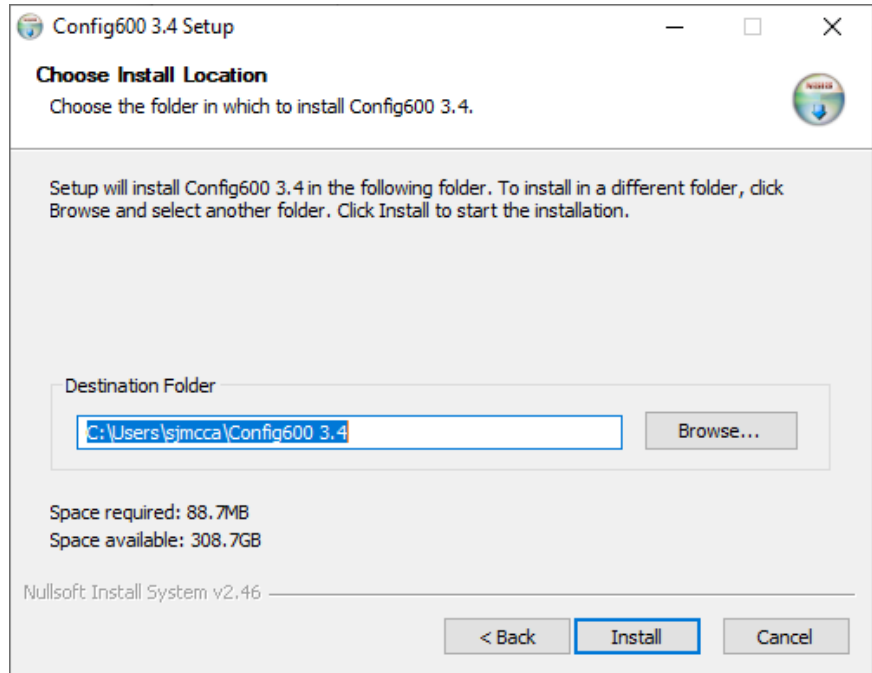

*Figure 1-4. Install Location*

6. Click **Browse** to select an alternative installation folder.
7. Click **Install**. As the installation proceeds, the installation wizard displays a screen showing the progress of the installation.

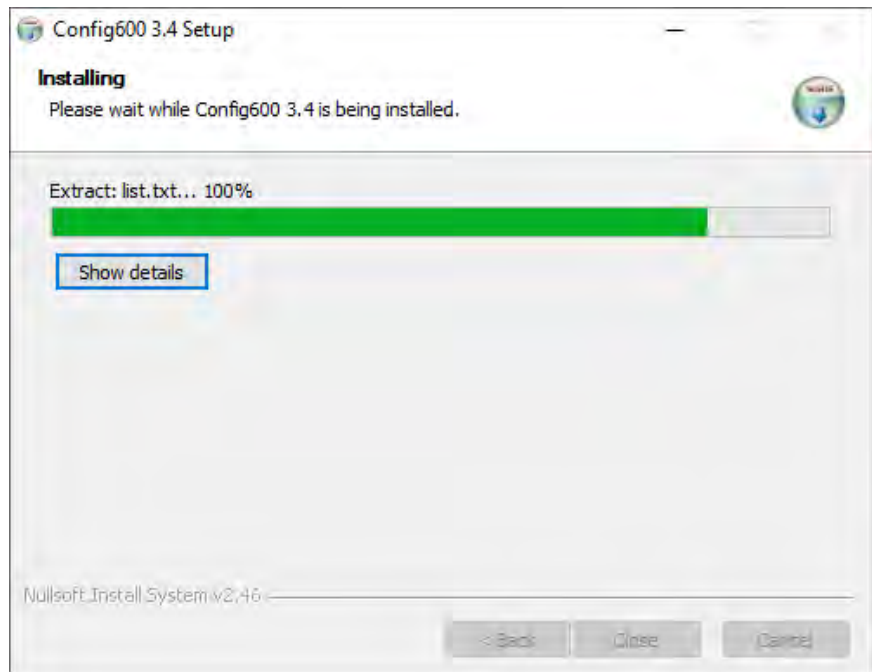

*Figure 1-5. Installation Progress*

8. When the installation completes, the wizard displays a completion screen.

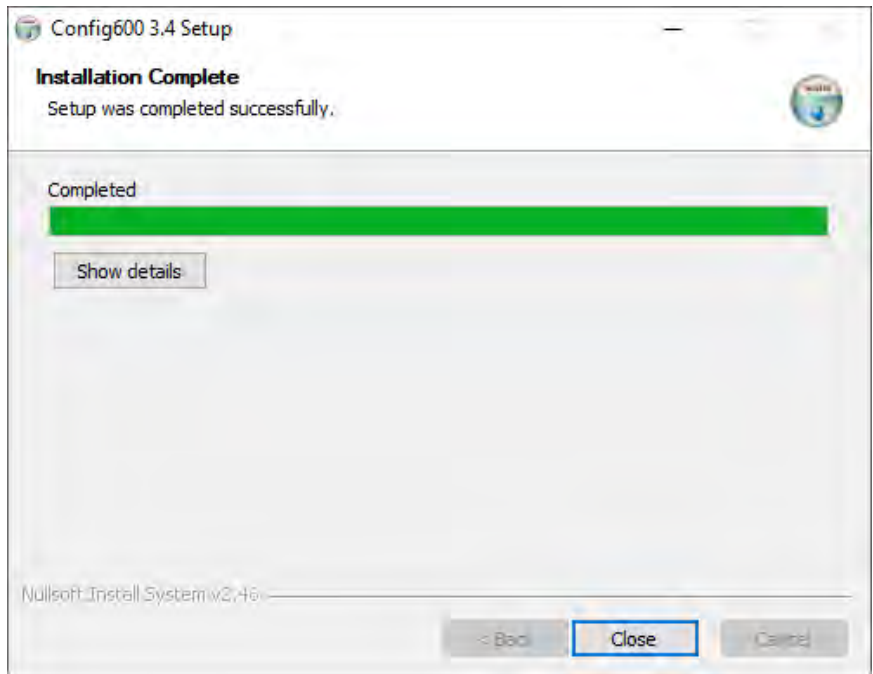

Figure 1-6. Installation Complete

9. Click **Close** to end the installation.

---

**Note:** You may need to restart your PC to complete the installation.

---

## 1.5 Accessing Config600

---



After you successfully install the Config600 software, you can access the application suite either of two ways.

- Create application-specific shortcut icons your desktop.
- Select **Start > All Programs > Config600 3.4** and select an application from the menu.

---

**Note:** If you have installed the Lite or Lite Plus version, that option appears in the selection menu.

---



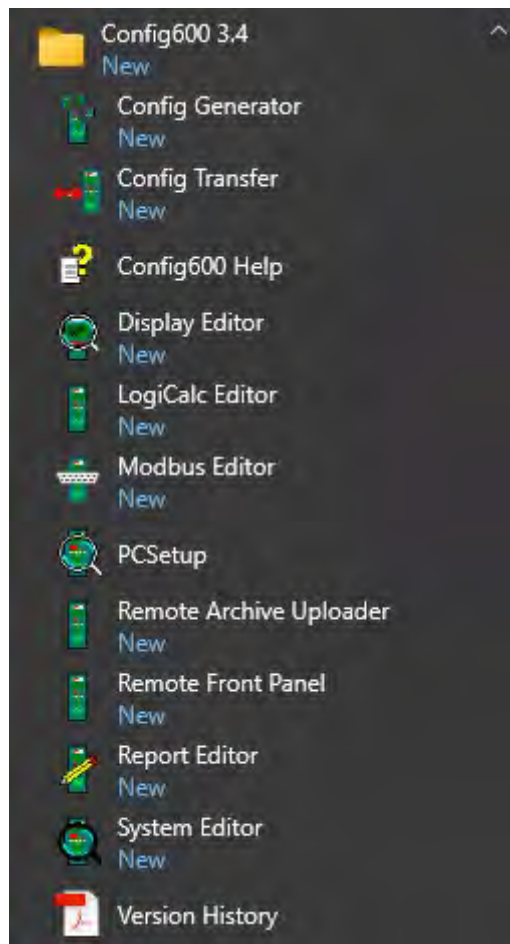

Figure 1-7. Config600 Menu

Which method you choose depends on personal preference. Proceed to *Chapter 2, PCSetup Editor*, for further information on the PCSetup utility.

## 1.6 Activating Config600

---

After you successfully install the software, you must next activate it. The activation screen (see *Figure 1-8*) displays when you attempt to open any of the Config600 component tools:

---

**Note:**

- Remote Archive Uploader can be used for a 30-day trial period after which an activation license **must** be obtained.
  - There is no trial period available for Lite / Lite+ / Pro – an activation license **must** be obtained before use.
-

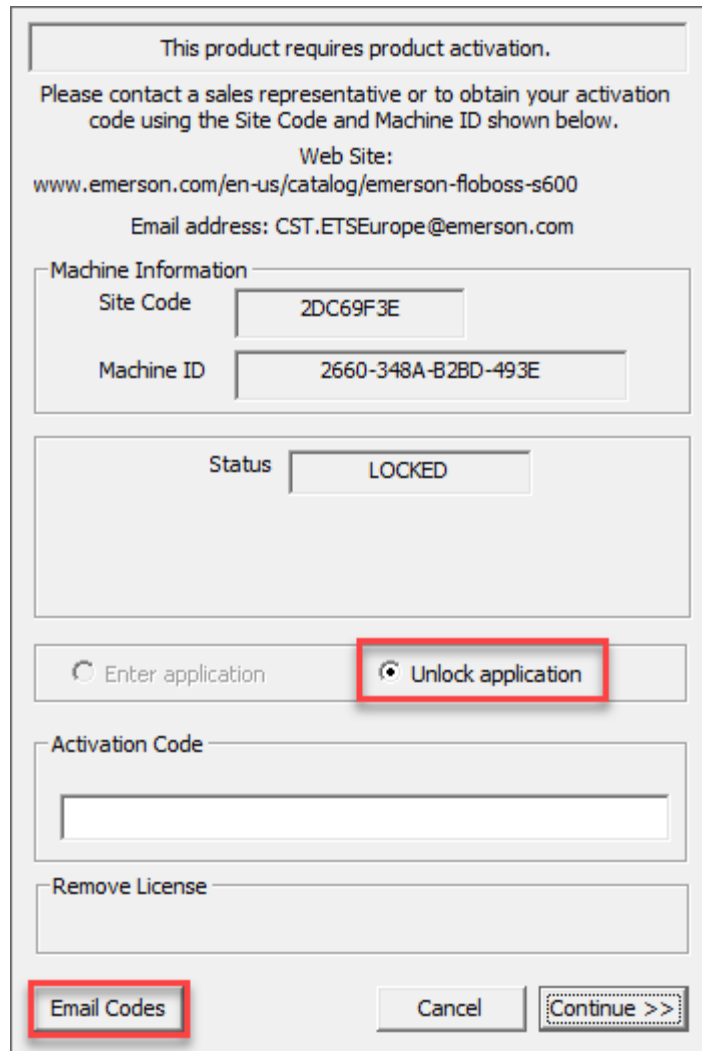

Figure 1-8. Config600 Activation Screen

Click **Email Codes** to send a request to *CST.ETSEurope@Emerson.com* for an activation code. The email automatically captures your Site Code and Machine ID.

---

**Note:** Each installation of Config600 is unique. Each copy of Config600 you install requires its **own** activation code.

---

Once you obtain an activation code, select **Unlock application**, enter the code in the Activation Code field, and click **Continue**. The Config600 utility you select opens.

---

**Note:** Config600 Pro activation codes/licences are issued **only** to those who successfully complete the RA901 Advanced Config600 training course.

---

**Re-installing Config600**

If you need to move your copy of Config600 to a new PC, un-install the software using PCSetup. The process generates a code you send to *CST.ETSEurope@Emerson.com*. You still need to provide the unique site code and machine ID.

Use the authorization code you receive in return to re-activate Config600.

**Changing the PC Clock** If you **manually** reset the clock on your PC, it is possible that Config600 may stop working and require you to re-authorize the software. This is not a problem if you allow the PC software to automatically accommodate changes for daylight saving time.

## 1.7 Additional Technical Information

Refer to the following technical documentation (available at [www.Emerson.com/EnergyandTransportation](http://www.Emerson.com/EnergyandTransportation)) for additional and most-current information.

*Table 1-2. Additional Technical Information*

<b>Document Name</b>	<b>Form Number</b>	<b>Part Number</b>
FloBoss™ S600+ Flow Computer Instruction Manual	A6115	D301150X412
FloBoss™ S600+ Flow Computer Product Data Sheet	S600+	D301151X012
Config600™ Configuration Software Product Data Sheet	Config600	D301164X012
FloBoss™ S600+ Field Upgrade Guide	A6299	D301668X412

*[This page is intentionally left blank.]*

## Chapter 2 – PCSetup Editor

### In This Chapter

2.1	Create a New Configuration.....	2-1
2.1.1	Name the Configuration (Step 1 of 6).....	2-2
2.1.2	Select Measurement Units (Step 2 of 6).....	2-3
2.1.3	Specify I/O (Step 3 of 6).....	2-4
2.1.4	Specify Stations (Step 4 of 6).....	2-5
2.1.5	Define Streams (Step 5 of 6).....	2-8
2.1.6	Select Communications (Step 6 of 6).....	2-16
2.2	Analyse a Configuration (System Graphic).....	2-17
2.3	Open an Existing Configuration (PCSetup Editor).....	2-23
2.3.1	Navigating the PCSetup Editor.....	2-25
2.3.2	The Icon Bar.....	2-27
2.4	The Menu Bar.....	2-27
2.5	Managing Configurations.....	2-29
2.5.1	Save a Configuration.....	2-29
2.5.2	Regenerate a Configuration.....	2-29
2.6	Display Editor.....	2-30
2.7	Config Transfer Utility.....	2-30
2.8	Config Organiser Utility.....	2-30

When you start Config600 Pro, the Welcome to Config600 screen displays (see *Figure 2-1*). Using this screen, you can create a new S600+ configuration, open an existing configuration, transfer data between a PC and the S600+, access on-line help, or control whether the Welcome screen displays when you start the software.

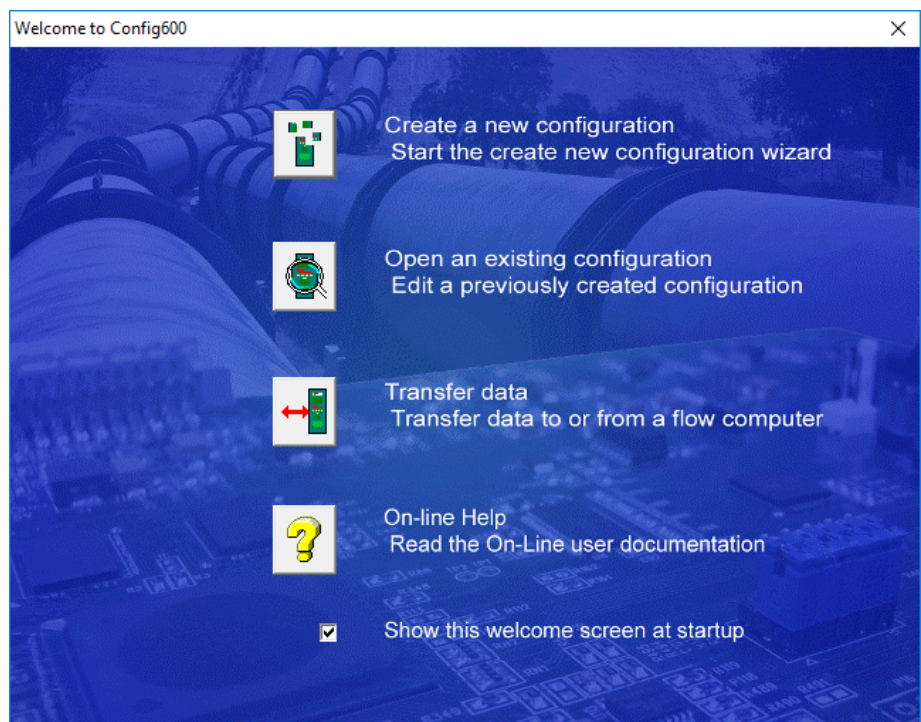

*Figure 2-1. Config600 Welcome*

### 2.1 Create a New Configuration

The Configuration Wizard provides several ways for you to create a new configuration:



- Click the New icon on the PCSetup Editor’s toolbar. 
- Click **Start > All Programs > Config600 3.3 > Config Generator**.
- Click the icon next to the **Create a new configuration option** from the PCSetup Editor’s Welcome to Config600 Screen (**View > Startup Screen**).

---

**Note:** You can also start the Configuration Generator by selecting **File > New** from the PCSetup screen. The Configuration Generator is included in both the Config600 Pro and Config600 Lite Plus software suites.

---

The Configuration Generator is a wizard-based software assistant that asks a series of questions to simplify the six-step process of creating a new S600+ configuration file. The wizard also validates your selections to prevent errors. Once you finish, the wizard saves the configuration settings to a file. You can modify the configuration and then send the configuration to the S600+.

### 2.1.1 Name the Configuration (Step 1 of 6)

---

**Note:** All screens in this section are examples intended to show all possible options and do not represent actual configurations.

---

Use the first screen in the wizard (*Figure 2-2*) to provide a name and brief description for the configuration file.

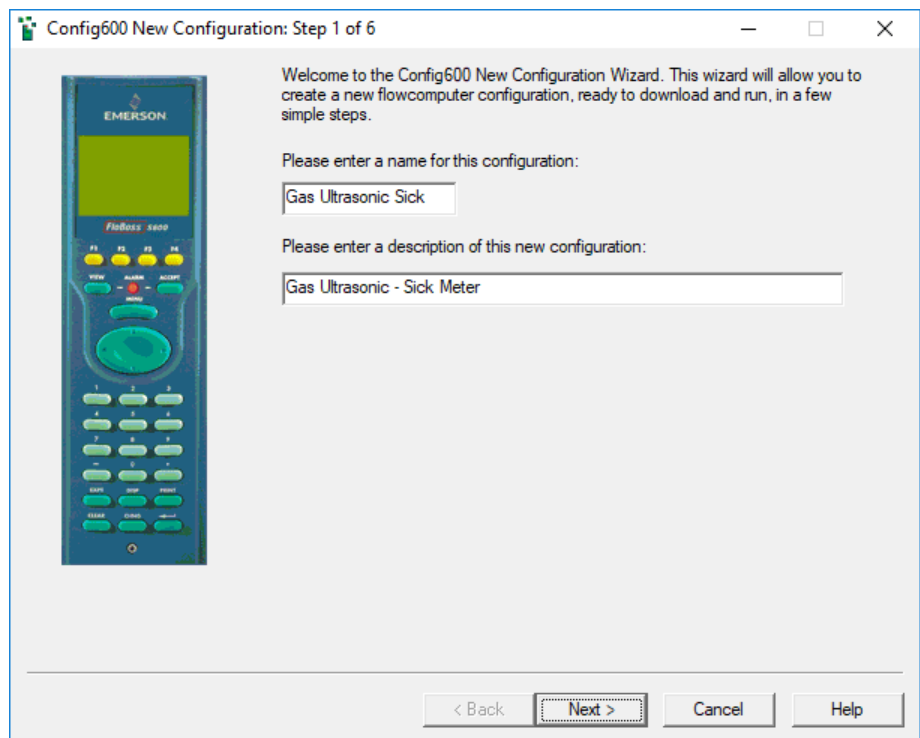

*Figure 2-2. Configuration Generator, Step 1*

1. Enter a name for the configuration. Keep the name short (up to 20 alphanumeric characters) for easy identification.

---

**Note:** This step is mandatory.

---

2. Enter a description for the configuration.

---

**Note:** The Configuration Generator displays the name you give the file on the running configuration. This **optional** description is for your information only.

---

3. Click **Next**.

## 2.1.2 Select Measurement Units (Step 2 of 6)

Use the second screen in the wizard (*Figure 2-3*) to set the units of measurement for the configuration.

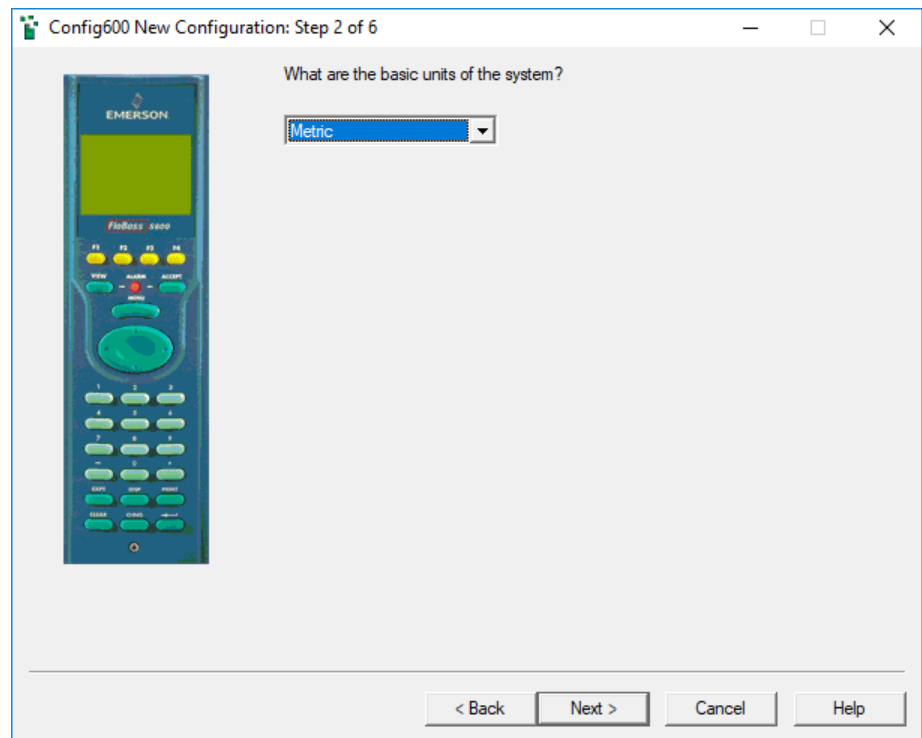

*Figure 2-3. Configuration Generator, Step 2*

1. Select the units of measurement the S600+ uses. Valid values are **Metric** or **Imperial**. The default is **Metric**. Click ▼ to display more values.

---

**Caution** This choice affects how Config600 handles a number of options, including the default ADC and PRT modes, maintenance mode interlock, alarm latch mode, and others.

---

**Note:** You can modify this initial setting after you complete the wizard.

---

2. Click **Next**.

### 2.1.3 Specify Modules (Step 3 of 6)

Use the third screen in the wizard (*Figure 2-4*) to indicate the number of I/O, optional HART, and optional prover modules installed in the S600+ for this configuration.

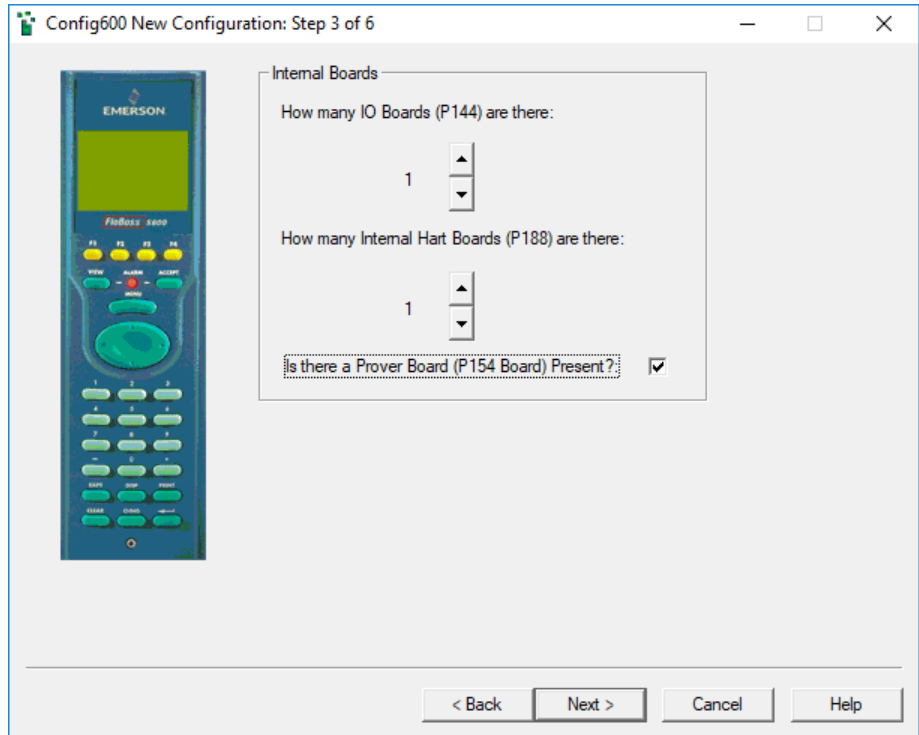

Figure 2-4. Configuration Generator, Step 3

1. Click ▼ and ▲ to indicate the number and kinds of modules physically installed in the S600+. The S600+ chassis can house up to three modules:

Module	Description
<b>I/O Module (P144)</b>	Each I/O module can handle up to two streams and include both analog and digital I/O. <b>Note:</b> You must include at least <b>one</b> I/O module in <b>each</b> configuration.
<b>HART Module (P188)</b>	This module enables the S600+ to communicate with HART® devices using the HART protocol. Each HART module has 12 channels, and each channel can accept up to eight devices. However, you cannot have more than 50 devices attached to any one HART module.
<b>Prover Module (P154)</b>	The Prover module provides the functions required for liquid prover applications. It is mandatory if you select a prover as part of this configuration. <b>Note:</b> You can include only <b>one</b> Prover module in <b>any</b> configuration.

2. Click **Next**.



## 2.1.4 Specify Stations (Step 4 of 6)

Use the fourth screen in the wizard (*Figure 2-5*) to indicate the number (up to two) and type (gas or liquid) of stations in the configuration. The wizard defaults to one gas station.

You can define a maximum of two provers (ball, compact, or master meter), one for each station.

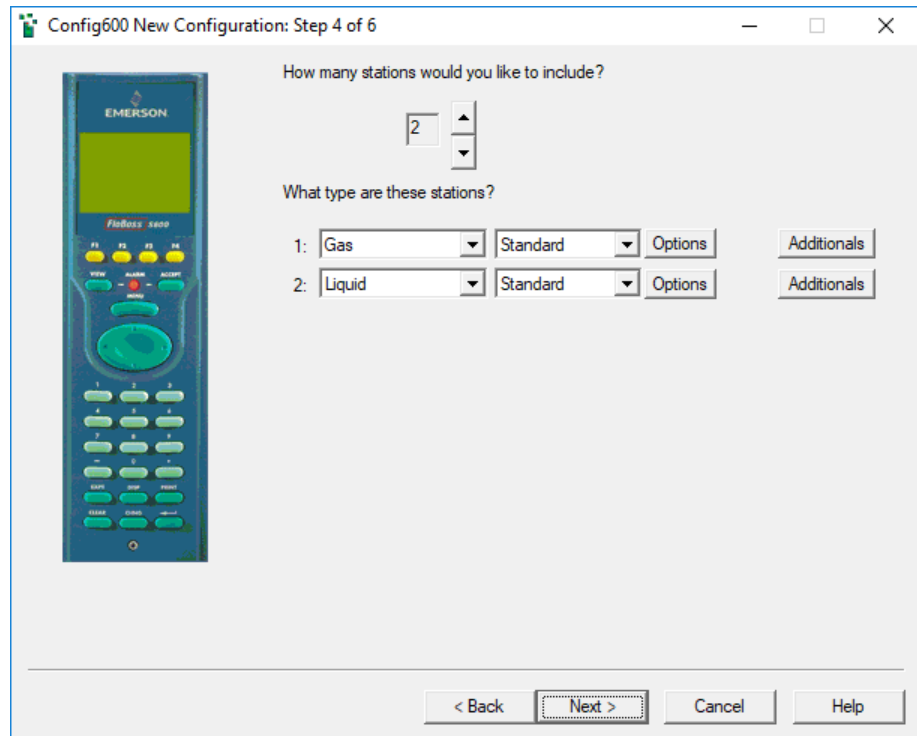

*Figure 2-5. Configuration Generator, Step 4*

1. Indicate the number of stations (to a maximum of two) for this configuration. Click ▼ or ▲ to add or delete stations.
2. Indicate whether the station handles **Gas** or **Liquid**. Click ▼ to display additional values. The default value is **Gas**.
3. Click **Options** to display a list of default values for each type of station. The station options for gas and liquid differ.

---

**Note:** As you modify these options, Config600 displays a summary of the options you select.

---

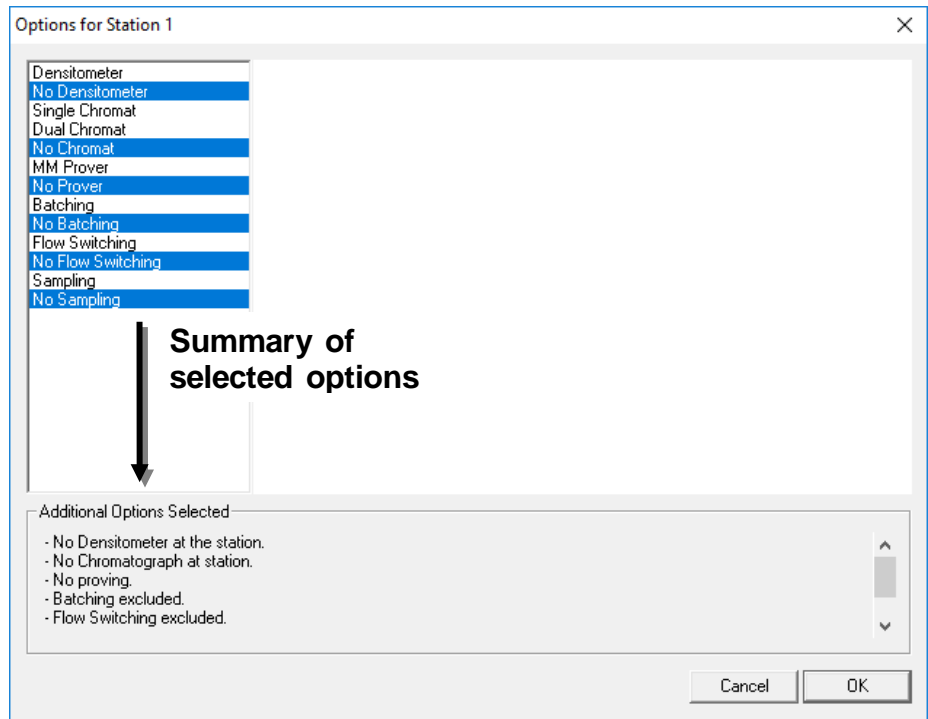

Figure 2-6. Gas Station Options Summary

- For a **Gas** station, select the appropriate options. Config600 initially highlights default values.

Option	Description
<b>Densitometer/ No Densitometer</b>	Performs calculations using densitometer input at the station.
<b>Single Chromat/ Dual Chromat/ No Chromat</b>	Performs calculations using chromatograph input(s) at the station.
<b>MM Prover/ No Prover</b>	Uses a Master Meter Prover. <b>Note:</b> <ul style="list-style-type: none"> <li>This option requires an associated metering stream.</li> <li>Only MM volume v Stream volume is supported.</li> </ul>
<b>Batching/ No Batching</b>	Performs station batch handling. Enable batch reports and totals.
<b>Flow Switching/ No Flow Switching</b>	Balances the station flow by opening and closing streams.
<b>Sampling/ No Sampling</b>	Performs single or twin can sampling.

**Note:** As you select options, the Additional Options Selected frame (at bottom of the Options screen) summarizes your selections (see *Figure 2-7*).

Summary of selected options

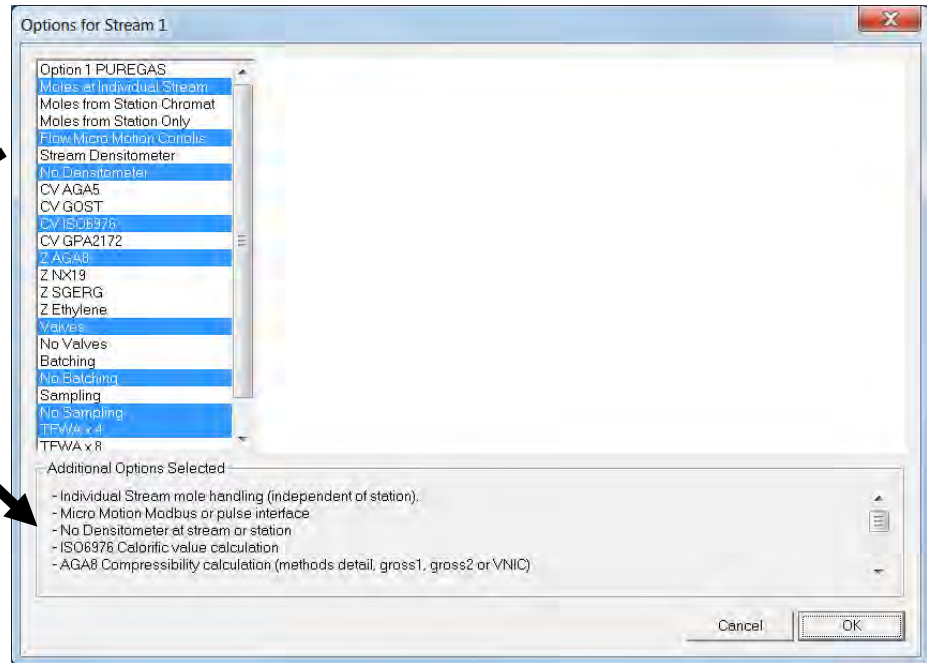

Figure 2-7. Gas Station Options Summarized

- For a **Liquid** station, select the appropriate options. Config600 initially highlights default values.

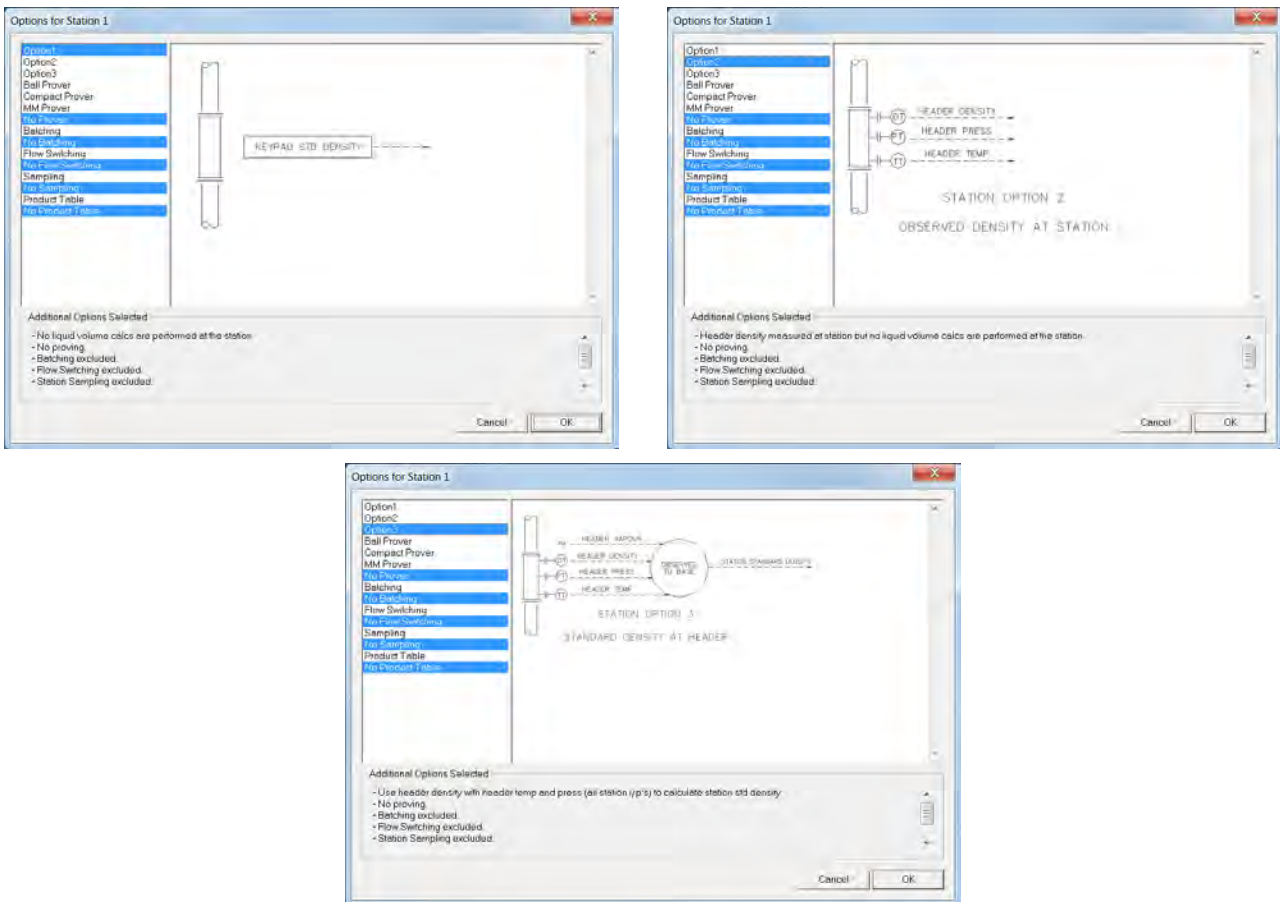

Figure 2-8. Liquid Station Options Summary screens

Option	Description
<b>Option1</b>	Performs no liquid volume calculations at the station. Station standard density is available as a keypad input.
<b>Option2</b>	Measures header density but performs no liquid volume calculations at the station.
<b>Option3</b>	Calculates station standard density using header density with header temperature and pressure at all station inputs.
<b>Ball Prover</b>	Uses a bi-directional or uni-directional prover. <b>Note:</b> Ball provers are also known as “pipe provers.”
<b>Compact Prover</b>	Uses a Daniels® Compact Prover™
<b>MM Prover</b>	Uses a master meter prover. <b>Note:</b> <ul style="list-style-type: none"> <li>▪ This option requires an associated metering stream.</li> <li>▪ The following combinations are supported: MM volume v Stream volume, MM volume v Stream Mass and MM Mass v Stream Mass.</li> </ul>
<b>No Prover</b>	Indicates this station does not perform prover runs.
<b>Batching</b> <b>No Batching</b>	Indicates if the station performs batch handling. Enable batch reports and totals.
<b>Flow Switching</b> <b>No Flow Switching</b>	Indicates if the station balances station flow by opening and closing streams.
<b>Sampling</b> <b>No Sampling</b>	Indicates if the station performs no sampling or twin can sampling.
<b>Product Table</b> <b>No Product Table</b>	Permits multiple product selection for pipeline batching applications. Select <b>No Product Table</b> to use a single product for continuous flow metering.

**Note:** As you select options, the graphic in the screen changes and the Additional Options Selected frame (at the bottom of the Options screen) summarizes your selections.

4. Click **Additional**s to include any optional calculations in the configuration. Config600 opens a text box you use to record the additional calculations.
5. Click **OK** when you finish adding optional calculations.
6. Click **Next**.

### 2.1.5 Define Streams (Step 5 of 6)

Use the fifth screen in the wizard (*Figure 2-9*) to associate streams and stations. You indicate the number of streams, the type of stream (gas, liquid, or RTU), link the stream to a station, and select stream options.

**Notes:**

- For station summation of stream flowrates to work correctly, all stations must have at least one stream configured.
- Although you can define up to 10 streams, a standard S600+ chassis can hold only three I/O modules. Each I/O module only has two dual-pulse inputs (2 turbines), so a standard S600+ can support only six dual-pulse turbine streams. However, it could support up to 10 single-pulse or 10 single-cell gas DPs.

Config600 uses the options you selected up to this point to determine operational values, including stream flow rate, density, flow weighted averages, and other specific values, for each type of stream (gas, liquid, or RTU).

**Note:** The **Graphic Preview** button that appears on this screen provides a graphic representation of your configuration.

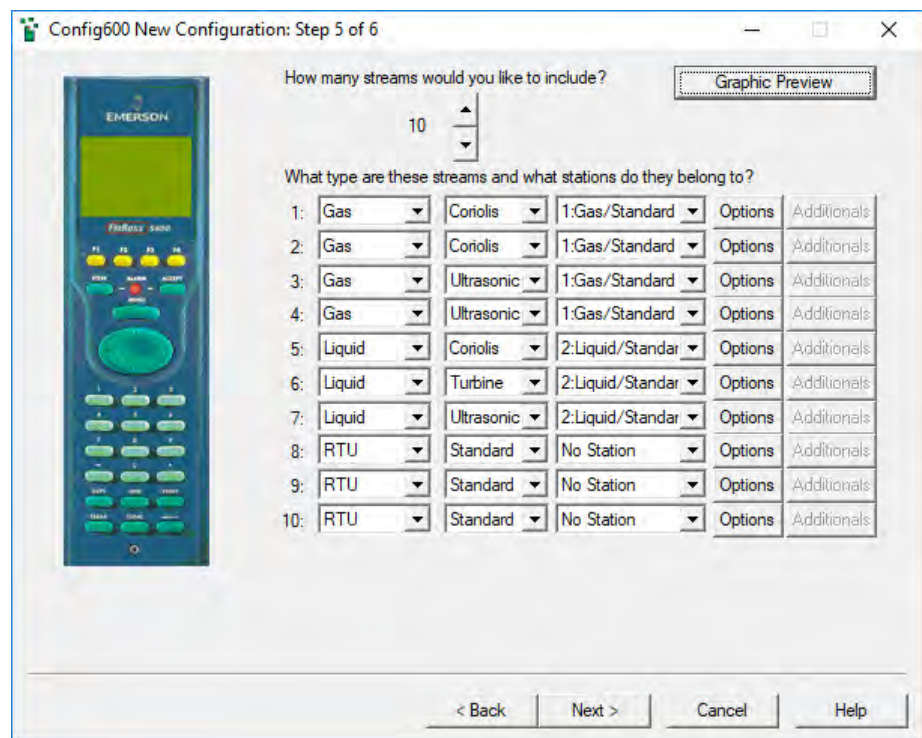

Figure 2-9. Configuration Generator, Step 5

1. Click ▲ or ▼ to add and delete streams (up to six dual-pulse or ten single-pulse). The screen initially displays only one stream.

**Note:** If you are configuring a bi-directional or compact prover application and require remote streams, then set the number of streams to 0. If you are configuring a master meter prover application and require remote streams, then you **must** configure at least one stream. Select **Next**. You will then be prompted to select the number of remote streams you require (up to 10).

2. Click ▼ to select a type (gas, liquid, or RTU) for each stream.

**Note:** So that S600+ flow computers can share information, you **must** group similar types of streams together (that is, gas with gas and liquid with liquid) and assign streams to stations. Config600 displays a warning message at the bottom of the screen and disables **Next** and **Graphic Preview**. Until you resolve these errors you cannot complete the configuration.

3. Click ▼ to select a meter to associate with each stream type.

Stream Type	Options
Gas	Coriolis, DP, Turbine, Ultrasonic
Liquid	Coriolis, Turbine, Ultrasonic
RTU	Standard ( <b>only</b> option)

4. Click ▼ to select a station for each stream-and-meter combination.

**Notes:**

- The RTU stream type essentially collects data for additional I/O handling and has no metering function. Consequently, you cannot associate an RTU stream with a specific metering station. **No Station** is the appropriate selection.
- If you defined two stations on screen 4, the wizard reflects those definitions in the choices at this step on screen 5.

5. Click **Options** to select the processing options for the first stream (in this example, **gas**). Config600 displays an Options summary screen with default values.

**Note:** The Options summary screens are different for gas, liquid, and RTU streams.

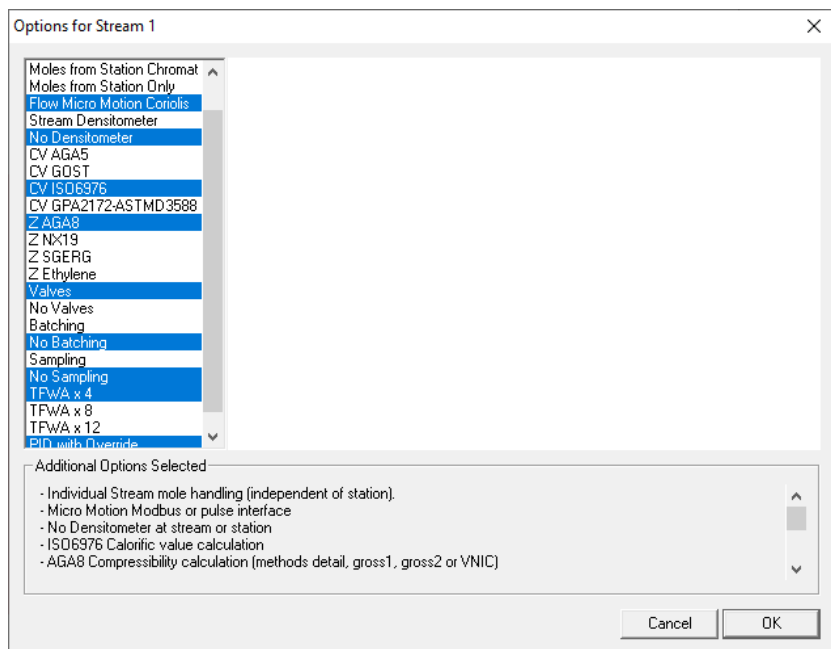

Figure 2-10. Gas Stream Options Summary

- For a **Gas** stream, select the appropriate options:

**Note:** The Options summary screens are different for **each** gas combination. This is a **general** list of **all** options; some options may not be available for your selected configuration.

Option	Description
<b>Option 1 GOST</b>	Determines GOST DP using SGERG calculations.
<b>Option 2 GOST</b>	Determines GOST DP using VNIC calculations.
<b>Option 3 PUREGAS</b>	Determines DP using standard PUREGAS calculations.
<b>Station Densitometer</b>	Measures density at station and transfers density to dependent stream. You must configure a station.
<b>Stream Densitometer</b>	Measures density at stream.
<b>No Densitometer</b>	Does not measure density at stream or station. This is a <b>default</b> .
<b>Moles from Station Chromat</b>	Uses selectively distributed (from station) analysis data telemetered from the chromatograph to streams with matching cycle number. Uses individual keypad sets.
<b>Moles from Station Only</b>	Uses station's in-use moles directly (that is, the station's common set). Does not use local stream moles.
<b>Moles at Individual Stream</b>	Uses stream moles directly (independently of local). This is the <b>default</b> .
<b>Flowrate AGA3 Volume</b>	Determines volume flowrate using AGA3 calculations.
<b>Flowrate AGA3 Mass</b>	Determines mass flowrate using AGA3 calculations.
<b>Flowrate ISO5167</b>	Determines flowrate using ISO5167 calculations. This is a <b>default</b> .
<b>Flowrate ISO5167 Wet Gas</b>	Determines flowrate using ISO5167 calculations for wet gas.
<b>Flowrate Annubar</b>	Determines flowrate using Annubar calculations.
<b>Flowrate VCone</b>	Determines flowrate using McCrometer V-Cone <sup>®</sup> calculations.
<b>Flowrate VCone Wet Gas</b>	Determines flowrate using McCrometer V-Cone calculations for wet gas.
<b>Flowrate Daniel</b>	Receives flowrate from a Daniel Junior or Senior sonic meter (4 path).
<b>Flowrate Rosemount 8 path</b>	Receives flowrate from a Rosemount 8 path ultrasonic meter.
<b>Flowrate QSonic</b>	Receives flowrate from a QSonic meter.
<b>Flowrate SICK</b>	Receives flowrate from a SICK meter.
<b>Flowrate SICK 8 path</b>	Receives flowrate from an 8 path SICK meter (FlowSic600-XT).
<b>CV AGA5</b>	Performs the AGA5 calorific calculation.
<b>CV GOST</b>	Performs the GOST calorific calculation.
<b>CV ISO6976</b>	Performs the ISO6976 calorific calculation. This is the <b>default</b> .
<b>CV GPA2172-ASTM D3588</b>	Performs the GPA2172-ASTM D3588 calorific calculation.

<b>Option</b>	<b>Description</b>
<b>Z AGA8</b>	Performs the AGA8 compressibility calculation using DETAIL, GROSS 0, GROSS 1, GROSS 2, or VNIC methods. This is the <b>default</b> .
<b>Z NX19</b>	Performs the NX19 compressibility calculation.
<b>Z SGERG</b>	Performs the SGERG compressibility calculation.
<b>Z PUREGAS</b>	Performs the pure gas compressibility calculation.
<b>Z Ethylene</b>	Performs ethylene and propylene compressibility calculation.
<b>Z Steam</b>	Performs compressibility calculation using steam tables.
<b>JT ISOTR9464</b>	Calculates the Joule-Thompson coefficient according to ISO/PDTR 9464 2005 section 5.1.5.4.4.
<b>Valves</b> <b>No Valves</b>	Indicates whether the stream monitors and optionally drives valves. <b>No Valves</b> is the <b>default</b> .
<b>Batching</b> <b>No Batching</b>	Indicates whether the stream performs batch monitoring and control. You need to configure batch reporting to include batch totals objects. <b>No Batching</b> is the <b>default</b> .
<b>Sampling</b> <b>No Sampling</b>	Indicates whether the stream performs twin can sampling. <b>No Sampling</b> is the <b>default</b> .
<b>TFWA x 4</b>	Indicates whether the stream calculates four time- and flow-weighted averages. This is the <b>default</b> .
<b>TFWA x 8</b>	Indicates whether the stream calculates eight time- and flow-weighted averages.
<b>TFWA x 12</b>	Indicates whether the stream calculates twelve time- and flow-weighted averages.
<b>PID with Overrides</b>	Indicates a single or dual PID control loop with override.

---

**Note:** As you select options, the Additional Options Selected frame (at the bottom of the Options screen) summarises your selections (this screen shows a variety of options). You may need to scroll down the summary to view all the summarised values.

---



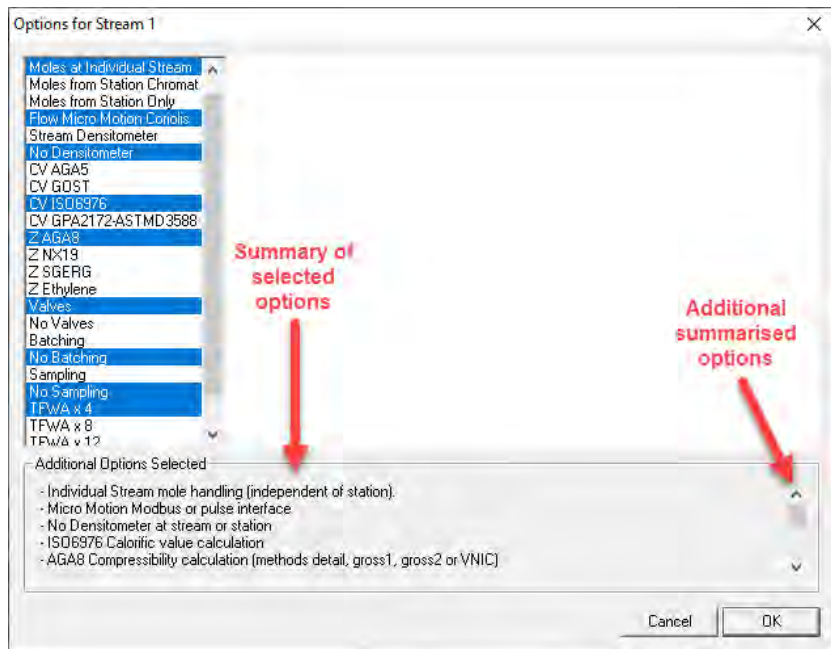
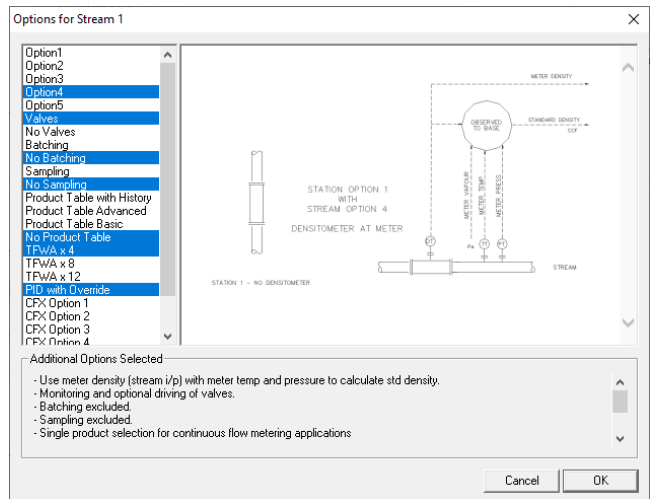
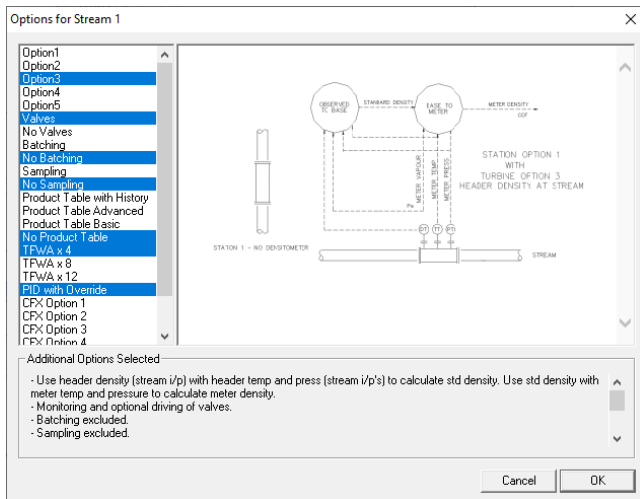
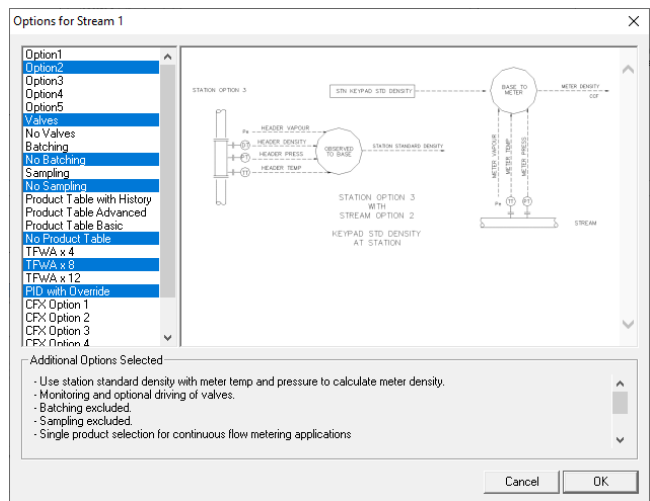
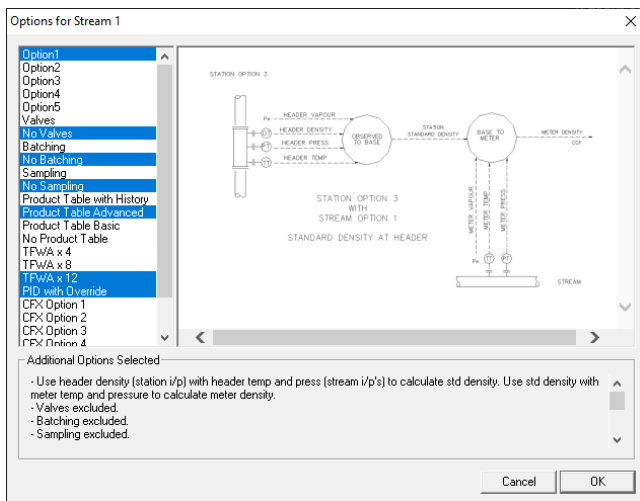

Figure 2-11. Gas Stream Options Summarized



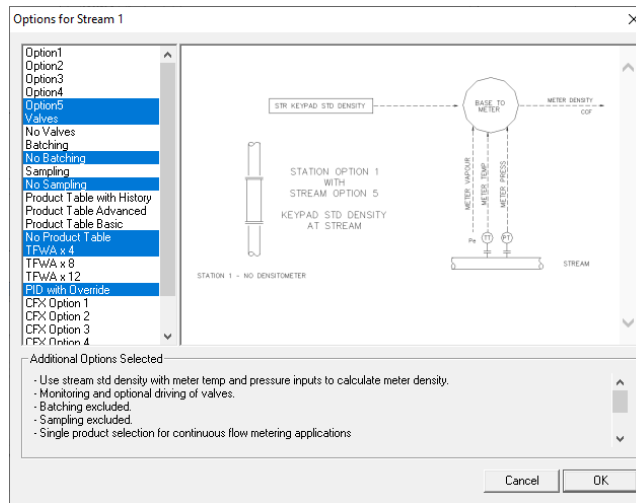

Figure 2-12. Liquid Stream Options Summary

- For a **Liquid** stream, select the appropriate options:

Option	Description
<b>Option1</b>	Calculates standard density using header density (from station input) with header temperature and pressure (from stream inputs). Calculates meter density using standard density with meter temperature and pressure.
<b>Option2</b>	Calculates meter density using station standard density and meter temperature and pressure.
<b>Option3</b>	Calculates standard density using header density (from stream inputs) with header temperature and pressure (from stream inputs). Calculates meter density using standard density with meter temperature and pressure.
<b>Option4</b>	Calculates standard using meter density (from stream inputs) with meter temperature and pressure.
<b>Option5</b>	Calculates meter density using stream standard density with meter temperature and pressure inputs. This is the <b>default</b> .
<b>Valves</b>	Indicates whether the stream monitors and optionally drives valves. <b>Valves</b> is the <b>default</b> .
<b>No Valves</b>	
<b>Batching</b>	Indicates whether the stream performs batch monitoring and control and configures batch reporting to include batch totals objects. <b>No Batching</b> is the <b>default</b> .
<b>No Batching</b>	
<b>Sampling</b>	Indicates whether the stream performs twin can sampling. <b>No Sampling</b> is the <b>default</b> .
<b>No Sampling</b>	
<b>Product Table with History</b>	Selects meter factor history and multiple products for batching applications with product-specific meter factor and K-factor curves for each product. <b>Note:</b> You <b>must</b> select Product Table with History in order to use the Prover MF Deviation Check stage.
<b>Product Table Advanced</b>	Selects multiple products (manual only) for pipeline batching applications with product-specific meter factor and K-factor curves for each product.
<b>Product Table Basic</b>	Selects multiple products (manual only) for

Option	Description
	pipeline batching applications with non-product-specific meter factor and K-factor curves.
<b>No Product Table</b>	Selects a single product for continuous flow metering applications. This is the <b>default</b> .
<b>TFWA x 4</b>	Indicates whether the stream calculates four time- and flow-weighted averages. This is the <b>default</b> .
<b>TFWA x 8</b>	Indicates whether the stream calculates eight time- and flow-weighted averages.
<b>TFWA x 12</b>	Indicates whether the stream calculates twelve time- and flow-weighted averages.
<b>PID with Override</b>	Indicates a single or dual PID control loop with override.

**Note:** As you select options, the graphic in the centre of the page changes (as shown in *Figure 2-12*), and the Additional Options Selected frame (at the bottom of the Options screen) summarises your selections. You may need to scroll down the summary to view all the summarised values (see *Figure 2-13*).

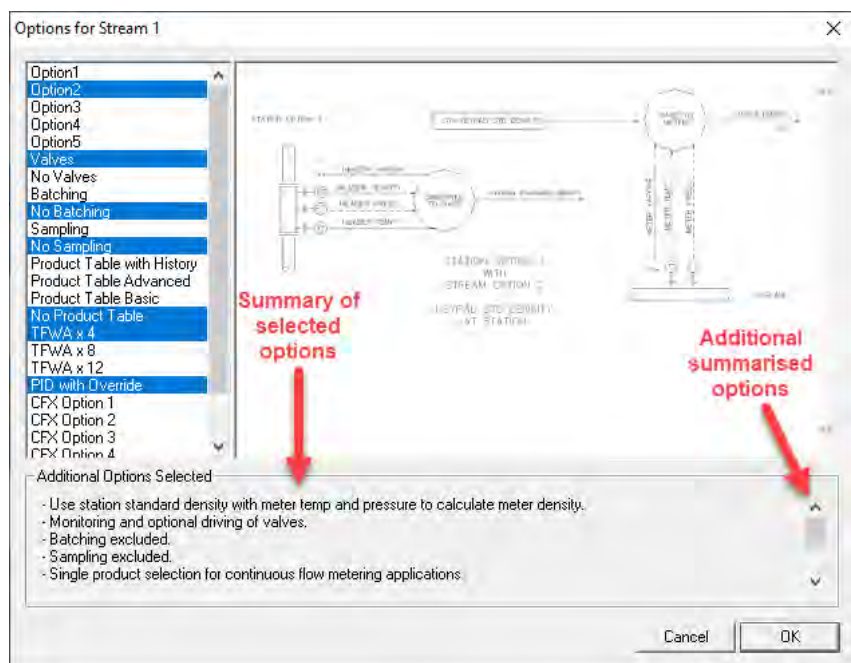

*Figure 2-13. Liquid Stream Options Summarized*

- For an **RTU** stream, the **only** valid station/stream combination is **Standard** and **No Station**.

**6. Click Next.**

**Note:** As you select options, Config600 checks to make sure your selections are valid and displays appropriate messages at the bottom of the screen (see *Figure 2-9*). If an **error** message displays, Config600 also greys out the **Next** button to prevent you from finalising an invalid configuration. You must resolve the configuration error **before** you can finalise your configuration in Step 6.

## 2.1.6 Select Communications (Step 6 of 6)

Use the sixth screen in the wizard (*Figure 2-14*) to indicate the external communications for the S600+. The selections depend on the defined stream and station types.

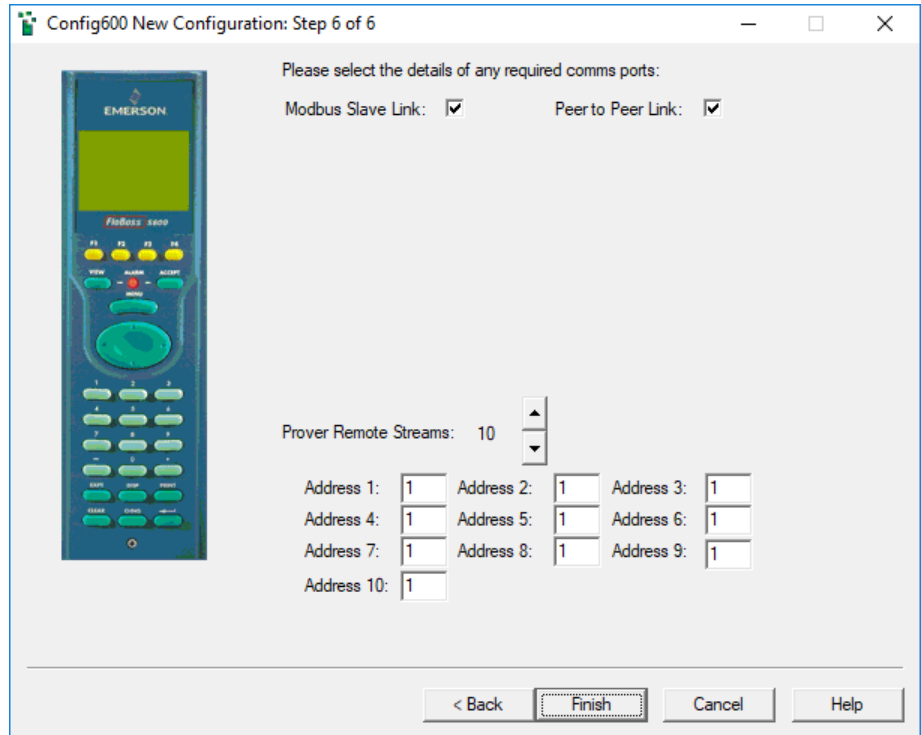

*Figure 2-14. Configuration Generator, Step 6*

1. Select the check boxes to include an optional Modbus slave link and Peer to Peer link in the configuration.

---

**Note:** The wizard displays only those options relevant to the configuration you have defined in the previous five screens. Valid port options (based on the configuration) include Modbus Slave, Peer to Peer, Chromatograph, Ultrasonic, Coriolis, and Prover.

---

2. Indicate the addresses for up to 10 prover remote streams.

**Notes:**

- This option appears if you define a single liquid station with a prover option (in Step 4) and **no** streams (in Step 5). Alternately, if you define a master meter (MM) prover in Step 4, that selection requires you to define one stream for data (Step 5).
  - If you define stream 1 and stream 2 in the same S600+, enter the **same** Modbus address for each stream. If the streams are in separate S600+s, enter **unique** addresses.
  - Prover remote streams enable you to define Modbus links to other S600+s. You can then use the station prover defined in this configuration to prove up to 10 other S600+s.
-

- Click **Finish** to complete the configuration process. (This may take several seconds to complete.) As the wizard creates the configuration and saves it to the Configs folder, a dialog box displays indicating progress:

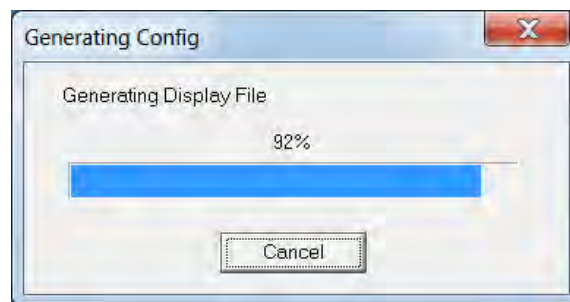

Figure 2-15. Generating Config dialog box

**Note:** The configuration generator can only create a new configuration where **all** of the metering streams are in the same unit as the prover or where **all** the metering streams are in different S600+ flow computers than the prover application. If you need to create a configuration where **some** metering streams are in a different S600+ and **some** streams are in the S600+ that houses the prover application, contact technical support.

- When the process completes, the S600 PCSetup screen redisplay, showing a graphic representation of your configuration. (Figure 2-16 is an example graphic):

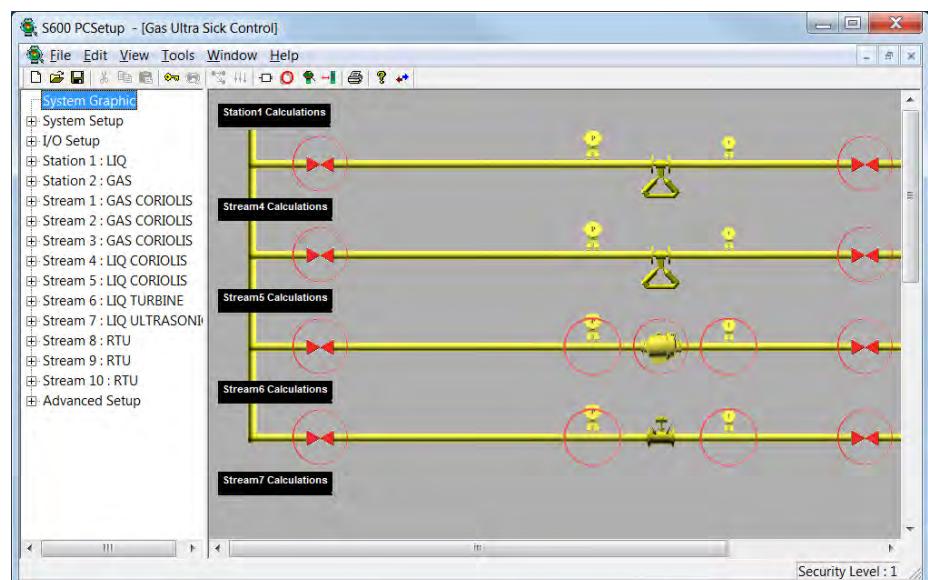

Figure 2-16. Example System Graphic

## 2.2 Analyse a Configuration (System Graphic)

**System Graphic** is the top-most option in the hierarchy menu located on the left side of the S600 PCSetup screen. This is also the default view whenever you open a configuration (see *Section 2.3, Open an Existing Configuration*).

The System Graphic provides a graphically based analysis of the configuration file you've created or selected. Using the graphic, you can quickly review station or stream settings or correct any errors in the configuration.

**Note:** For further information on selecting and assigning input options, refer to *Chapter 5, Station Configuration* or *Chapter 6, Stream Configuration*.



Figure 2-17. System Graphic (Stations and Streams)

In the figure above, note the black rectangles labeled *Station1 Calculations* and *Stream1 Calculations*. When you move the cursor over one of these blocks, Config600 expands that block to show all the values defined for that stream or station:

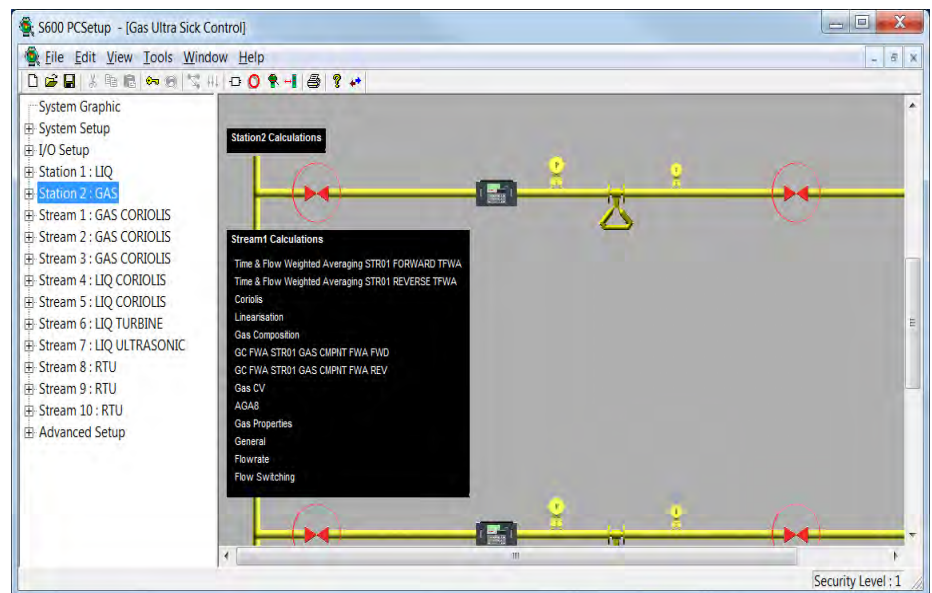

Figure 2-18. Stream Values (expanded)

If necessary, you can click on a value in the expanded block (such as *Gas Properties*) to display the Config600 screen that defines those values:

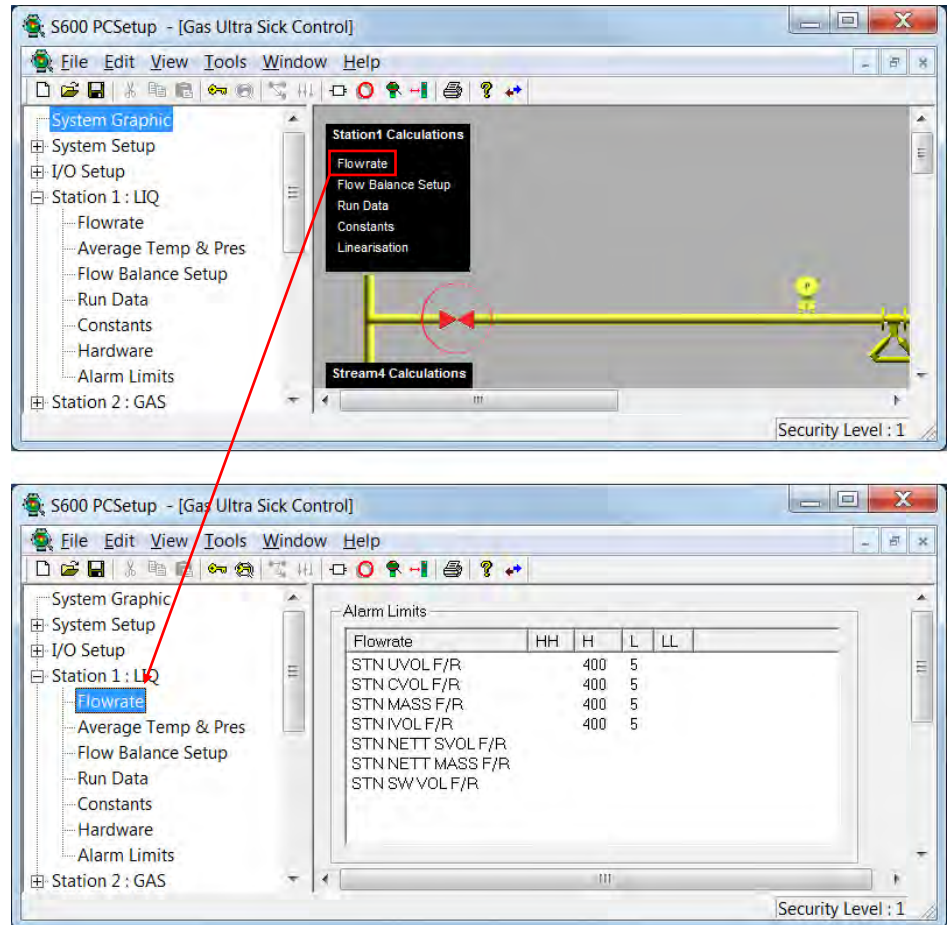

Figure 2-19. Value selection (expanded)

Red circles in the System Graphic alert you to unassigned inputs. When you click on a red circle, Config600 displays a screen within the system hierarchy you can use to assign those inputs.

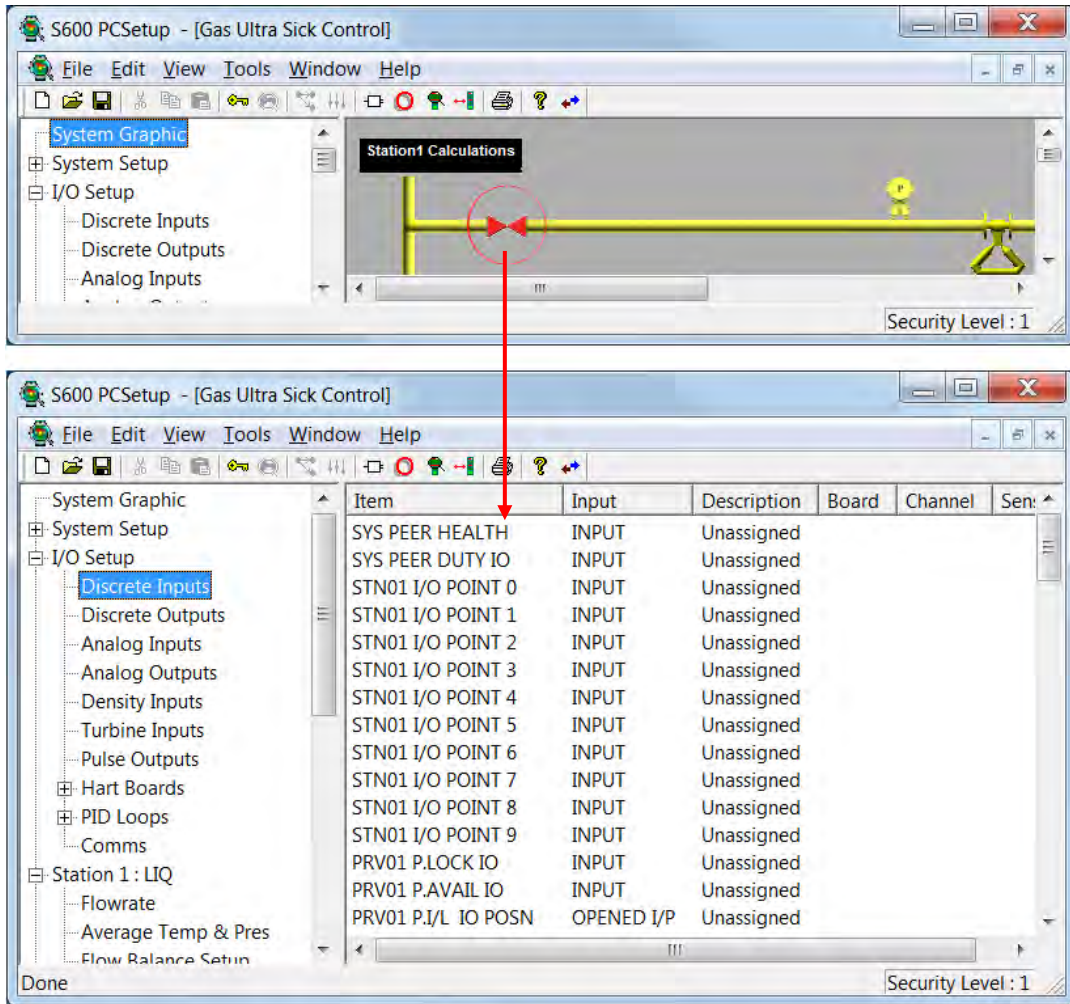

Figure 2-20. Input Values (expanded)

Once you assign inputs, you can reselect **System Graphic**. Config600 removes the red alerting circles (as in the case of the analogue meters):



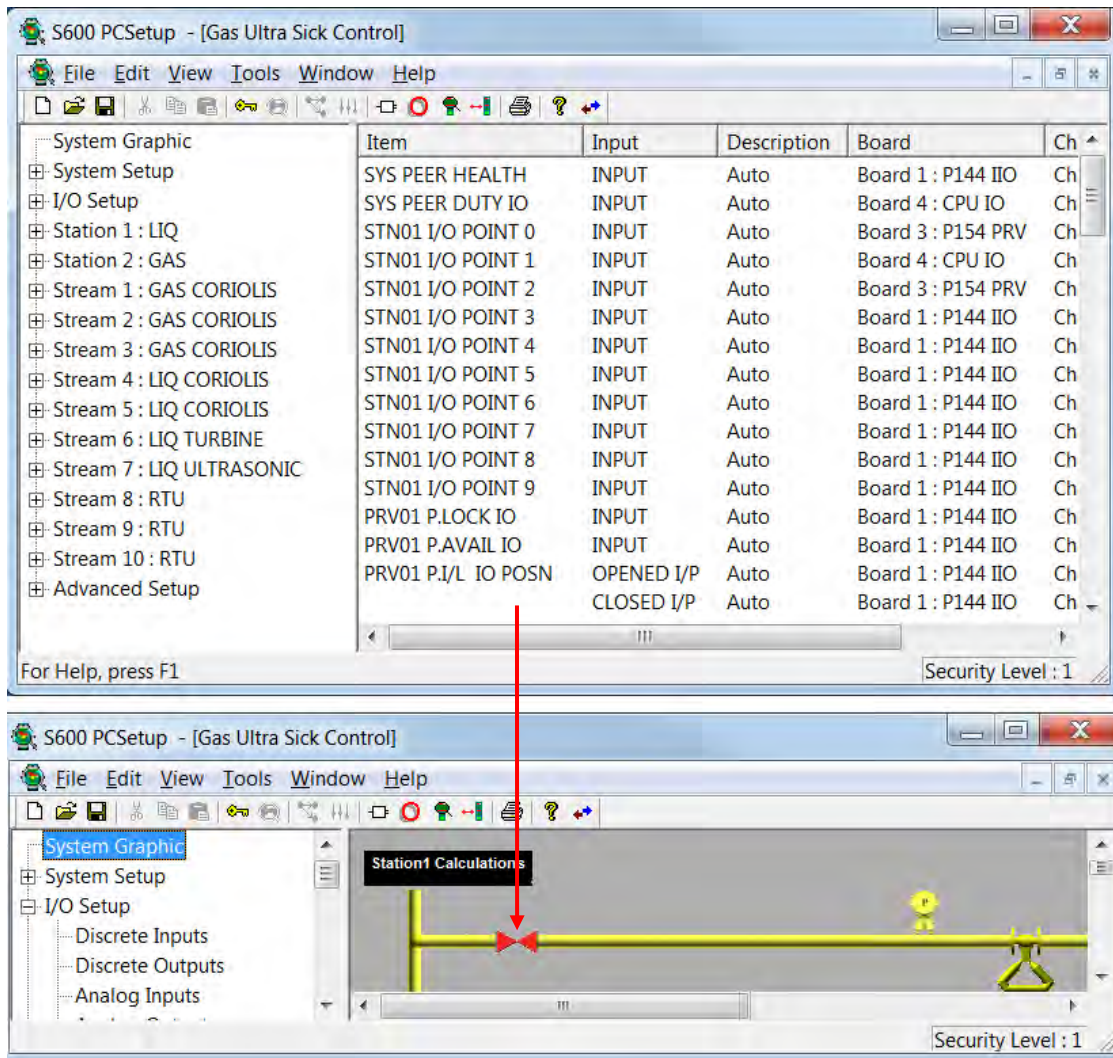

Figure 2-21. Input Values (assigned)

In addition to alerting you to inputs you may need to assign, the System Graphic also provides other icons you can select. When you move the cursor over a selectable icon, the cursor changes to the image of a hand. For example, double-clicking the communication icon accesses the Communications screen:

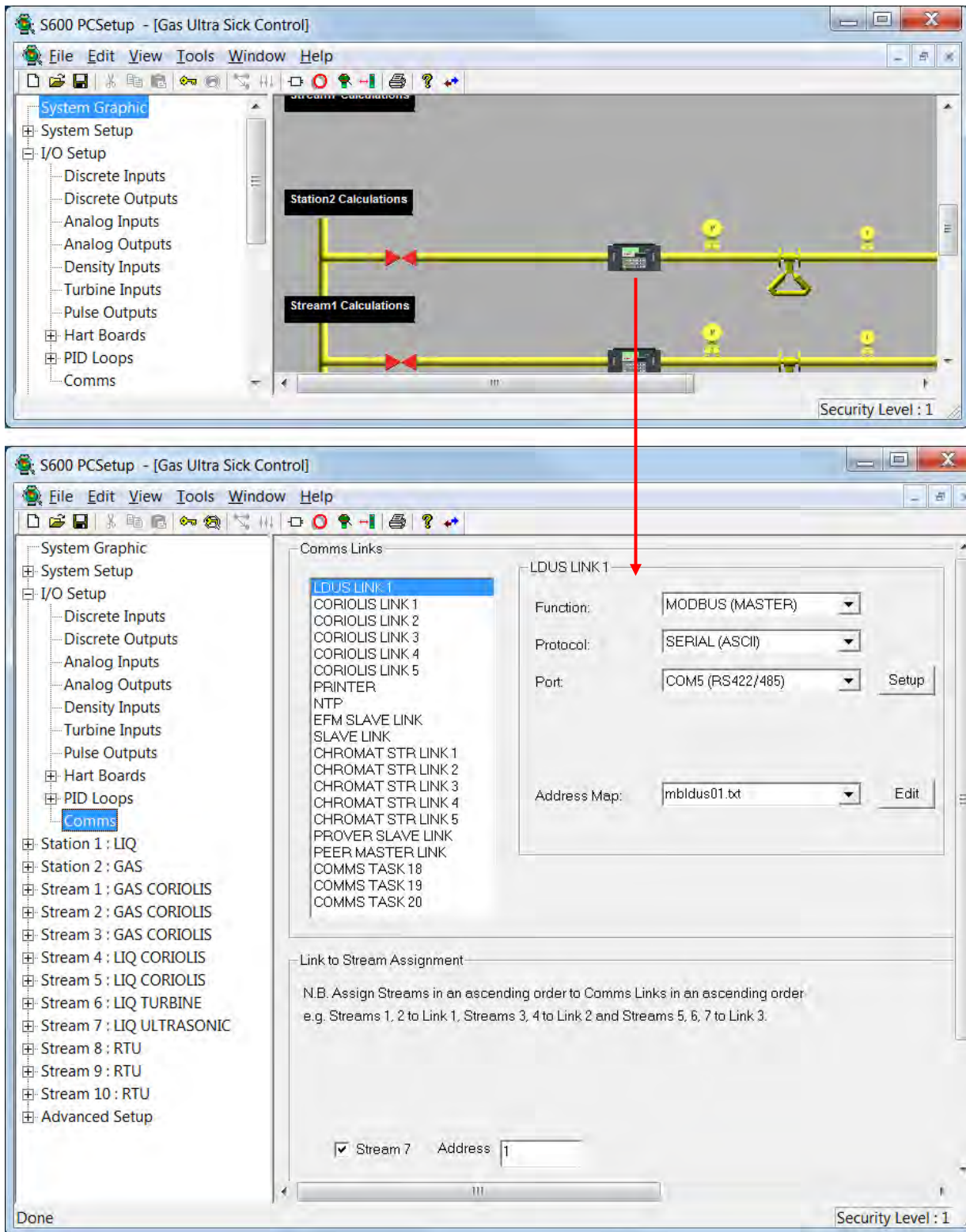

Figure 2-22. Selectable icons

Once you are familiar with system components, you can use the System Graphic to review and modify the components of your configuration file.

## 2.3 Open an Existing Configuration (PCSetup Editor)

Using the Configuration wizard you can quickly create a basic configuration file. You can then use the PCSetup Editor to edit and customize the basic settings in an existing configuration file to meet an application's specific requirements.

**Note:** While you **cannot** edit a configuration file that resides and is active (online) on the S600+, it is possible to change the configuration using the Front Panel or Webserver.

Editing a configuration includes changing the default values and setting alternative I/O configurations, screen definitions, report formats, and external communications links. You can:

- Change measurement units.
- Configure reports.
- Assign and re-assign I/O.
- Configure communications links.
- Enable/disable alarms.
- Change cold start values (such as densitometer constants).
- Change descriptors.
- Configure existing calculations.
- Change passwords.

**Note:** You **cannot** add new calculations to a configuration using the PCSetup Editor.

To edit an existing configuration file:

1. Open a configuration file in one of several ways:



- Click the Open icon on the PCSetup Editor's toolbar.
- Click **File > Open** in the PCSetup Editor.



- Click the icon next to the **Open an existing configuration** option on the Welcome to Config600 screen (*Figure 2-1*) to open a previously created configuration file.

The Select Config screen displays:

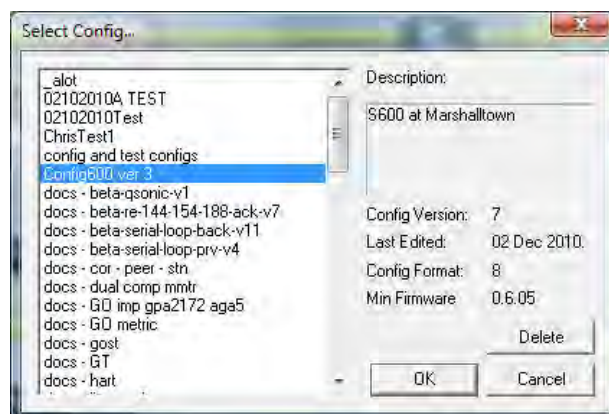

Figure 2-23. Select Config...

2. Click the name of a configuration file in the left-hand pane. Note that the **OK** and **Delete** buttons in the right-hand pane become active, and the software completes the following fields:

Field	Description
<b>Description</b>	Displays the description you assigned to this configuration in Step 1 of the configuration wizard.
<b>Config Version</b>	Indicates the number of times the configuration file has been edited and saved since its creation. The system increments this number only when you save a configuration.
<b>Last Edited</b>	Indicates the date the configuration was last saved.
<b>Config Format</b>	Identifies the template version number used to generate the configuration file.
<b>Min Firmware</b>	Identifies the minimum version of firmware that supports the configuration file.
<b>OK</b>	Click to open the selected configuration file.
<b>Cancel</b>	Click to cancel the action and close this window.
<b>Delete</b>	Click to delete this configuration from the Config folder.

3. Click **OK**. The system opens a configuration-specific S600 PCSetup screen (note the change in the heading for the screen), displaying a graphic representation of that configuration:

---

**Note:** If the existing configuration folder contains an exback file (generated when the backup command is utilised on the FloBoss S600+ and the configuration uploaded to a PC), then a popup window appears asking if the data from the exback file should be synchronised with the data in PCSetup. For more details refer to *Appendix L – Backup Functionality*.

---

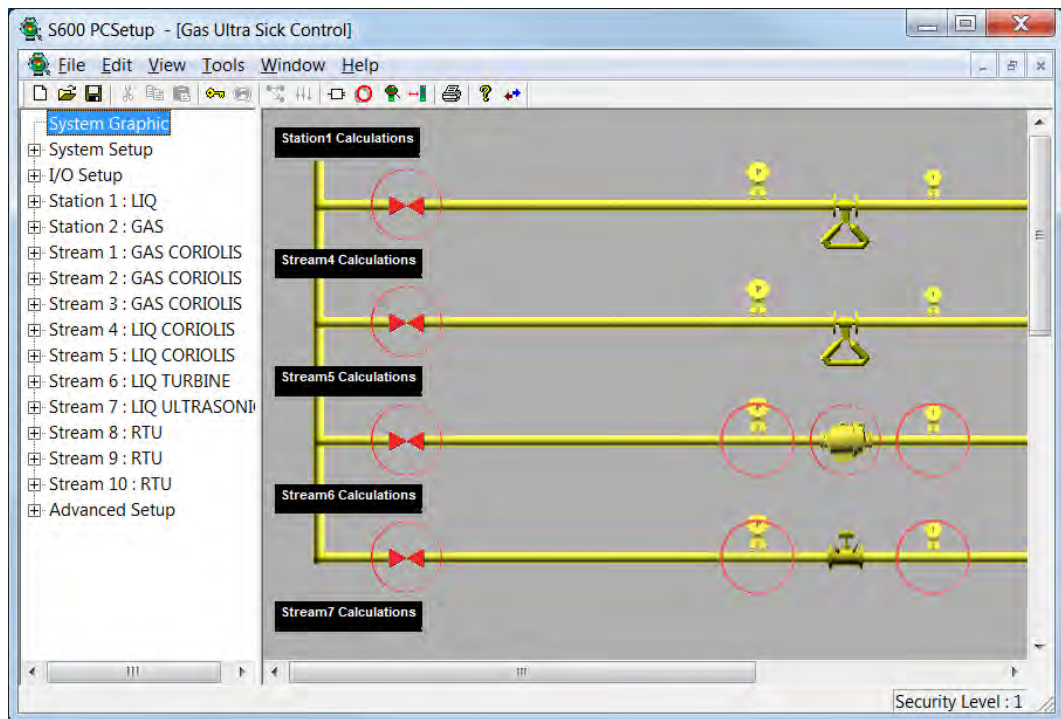

Figure 2-24. Configuration-specific System Graphic

Refer to *Section 2.2* for further information on using the System Graphic.

---

**Note:** By default, PCSetup logs you in at Security Level 1 (as shown in the lower right-hand corner of the screen). Level 1 has the greatest access to software features and functions; level 9 has the most restrictions. Refer to *Security in Chapter 7, Advanced Setup Configuration*, for further information on defining security levels.

---

### 2.3.1 Navigating the PCSetup Editor

The PCSetup Editor window consists of two panes: a hierarchy menu in the left-hand pane and various configuration screens that appear in the right-hand pane. *Figure 2-25* shows a sample screen.

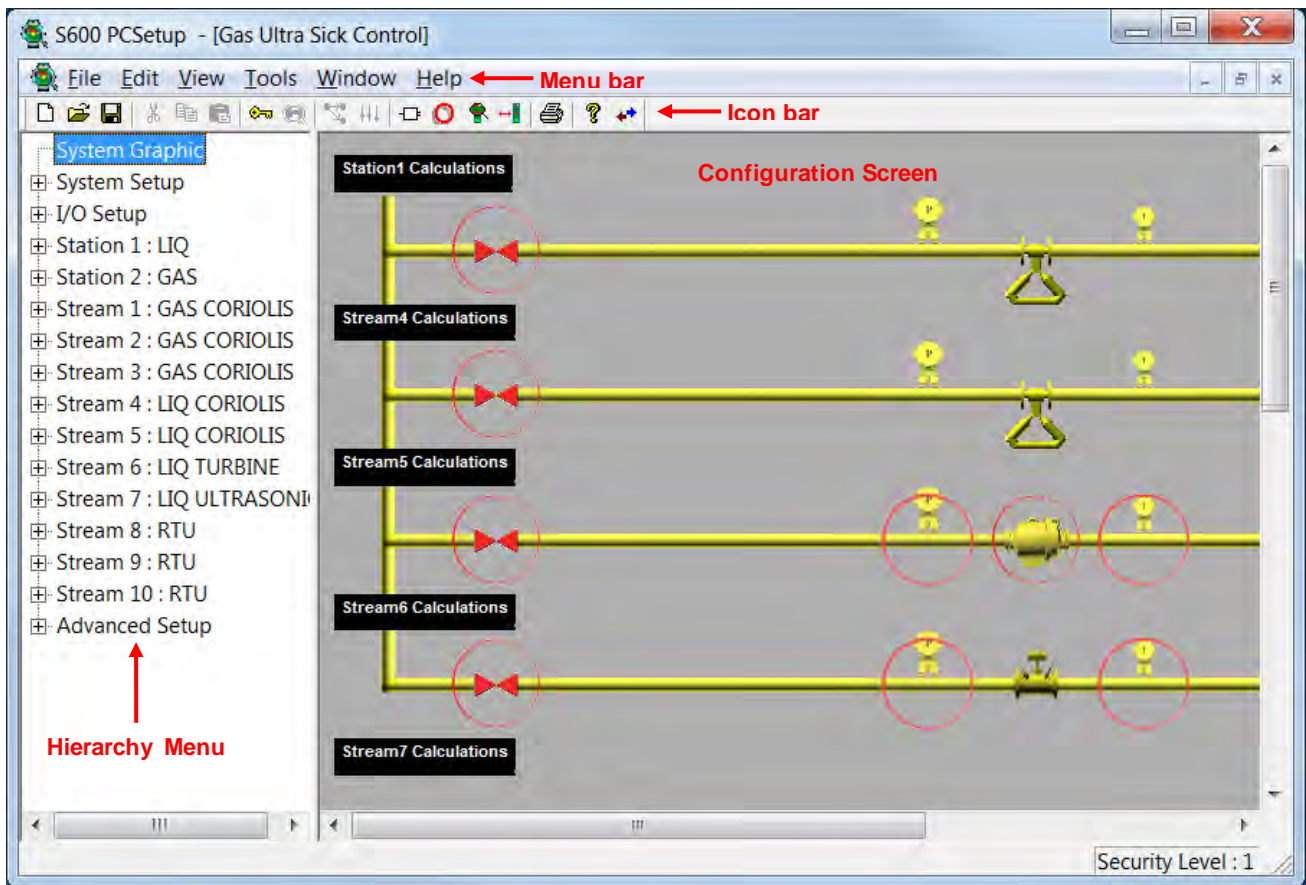

Figure 2-25. PCSetup Editor

Located on the left-hand side of the screen, the hierarchy menu displays the major configuration components: System Graphic, System Setup, I/O Setup, Station(s), Stream(s), and Advanced Setup. Clicking on an item in the hierarchy menu displays a sub-menu. Each sub-menu has an associated configuration screen.

Refer to the following for information on each configuration component:

- System Graphic: *Section 2.2 of Chapter 2*
- System Setup Configuration: *Chapter 3.*
- I/O and Communications: *Chapter 4.*
- Stations: *Chapter 5.*
- Streams: *Chapter 6.*
- Advanced Setup: *Chapter 7.*















The configuration screens on the right-hand side of the screen contain parameter fields, check boxes, and buttons. Fields allow you to type characters and numbers or to select from drop-down lists. Check boxes enable you to select specific options. Buttons link to dialog boxes that allow you to configure a data point or parameter.

Located at the top of the PCSetup Editor screen, the menu bar and icon bar have the customary Windows-based software options, plus additional menu selections and icons specific to Config600.

## 2.3.2 The Icon Bar

The icon bar, located immediately below the menu bar at the top of the screen, provides icons for the following actions or shortcuts:

Table 2-1. Config600 Icon Bar

Icon	Meaning
	New Configuration. Click this icon to open the Config600 Configuration Generation screen sequence. <b>Note:</b> This applies <b>only</b> to the Config600 Pro software.
	Open Configuration. Click this icon to open the Select Config dialog box.
	Save Configuration. Click this icon to save the current configuration with the current configuration file name.
	Cut, Copy and Paste. These clipboard icons are available if not greyed out. Click Cut to remove the selection from the clipboard. Click Copy to store the selection to the clipboard. Click Paste to insert the contents of the clipboard at the cursor's location.
	Login. Click this icon to open the Login dialog box. <b>Note:</b> This applies <b>only</b> if Level 1 security has been enabled.
	Edit Security. Click this icon to open the Edit Security dialog box.
	Assignment. Click this icon to open the Edit Assignments dialog box for the selected data point.
	Settings. Click this icon to open the Edit Settings dialog box for the selected data point.
	Calc Explorer. Click this icon to open the Calc Explorer utility, and examine calculation relationships between system components.
	Config Organiser. Click this icon to display a Config Organiser and add, clone, delete, rename, or reorder components of a configuration.
	Displays. Click this icon to open the Display Editor (see <i>Chapter 13, Display Editor</i> ).
	Config Transfer. Click this icon to open the Config Transfer utility. (see <i>Chapter 9</i> ).
	Print. Click this icon to open the Print dialog box. Use this icon to print the relevant pane selection to a host printer.
	About Config600. Click this icon to open the About Config600 dialog box that displays copyright and version information.

## 2.4 The Menu Bar

The menu bar, located immediately above the icon bar at the top of the screen, provides the following actions or shortcuts:

Table 2-2. Config600 Menu Bar

Menu	Meaning
<b>File Menu</b>	Use these menu options to print, open, close, and save configuration files.
<b>New</b>	Creates a new configuration file.
<b>Open</b>	Opens an existing configuration file.
<b>Close</b>	Closes an open configuration file.

Menu	Meaning
	<b>Save</b> Saves the selected configuration file.
	<b>Save As</b> Saves the selected configuration file with a different name.
	<b>Login</b> Login to the PCSetup Editor.
	<b>Print</b> Prints the screen currently shown in Config600.
	<b>Print Preview</b> Opens the selected configuration file in the print preview window.
	<b>Print Setup</b> Opens the Windows Print Setup window to configure your default printer.
	<b>Recent File</b> Opens or view recently edited configuration files.
	<b>Regenerate</b> Regenerates the selected configuration file to overwrites all modifications to displays and Modbus maps with the standard displays and Modbus maps as generated at the build time of the configuration. <b>Note:</b> To regenerate a report, delete the report and add the report using <b>PCSetup Editor &gt; System Setup &gt; Reports.</b>
	<b>Exit</b> Closes the PCSetup Editor.
<b>Edit Menu</b>	Use these menu options to open the Config Organiser, Assignment, and Settings screens.
	<b>Undo, Cut, Copy, &amp; Paste</b> These functions are disabled in the PCSetup Editor.
	<b>Config Organiser</b> Launches the Config Organiser to arrange the priority of configurations so a certain I/O is read before another, rename or clone I/O modules, streams or stations, and delete I/O modules.
	<b>Security</b> Restricts access to authorised system users and determines which data items system users can enter or modify.
	<b>Assignment</b> Opens the Edit Assignments dialog box for the selected data point.
	<b>Settings</b> Opens the Edit Settings dialog box for the selected data point.
<b>View Menu</b>	Use these menu options to view the Tool bar, Status bar, change the frame sizes, and open the Startup Screen.
	<b>Tool Bar</b> Views or hides the Tool Bar.
	<b>Status Bar</b> Views or hides the Status Bar.
	<b>Split</b> Changes the frame sizes.
	<b>Startup Screen</b> Launches the initial Startup Screen.
<b>Tools Menu</b>	Use this menu to open the Display Editor or the Config Transfer utility.
	<b>Edit Displays</b> Opens the Display Editor.
	<b>Transfer</b> Opens the Config Transfer utility.
<b>Windows Menu</b>	Use these menu options to configure how your screens display, clone a configuration, arrange icons, and view or select open configurations.
	<b>New Window</b> Opens a second instance of the configuration file in a new window to view a different screen.
	<b>Cascade</b> Displays all open configuration windows in a Cascade view.
	<b>Tile</b> Displays all open configuration windows in a Tile view.
	<b>Arrange Icons</b> Arranges icons according to a grid pattern.
	<b>Open Configurations</b> Opens active configurations.
<b>Help Menu</b>	Use these menu options to access the online help system and view the About PCSetup information screen.



Menu	Meaning
<b>Contents</b>	Accesses the online help system.
<b>About PCSetup</b>	Displays the About PCSetup dialog box, which contains information about the software (including the version number).

## 2.5 Managing Configurations

This section discusses how to save and regenerate a configuration.

### 2.5.1 Save a Configuration

To avoid losing any work as you develop your configuration, it is a good practice to save the configuration file after you make any changes.

Config600 creates a separate folder in your computer's Config600 folder for each unique configuration. At your request, Config600 saves the configuration files in your computer's Configs folder using the file extension ".cfg" for the master configuration file. Other components have individual sub-folders:

- **Reports:** Contains the report format files.
- **Modbus:** Contains the Modbus configuration files.
- **Logicalcs:** Contains the custom written files that allow user-defined functions.
- **Extras:** Stores user-defined look-up tables and configuration backup files.
- **Logs:** Stores a copy of the backup synchronization file and the auto-generated log file created when the wizard selections are made.

To save the configuration file, select **File > Save** or **File > Save As** while in any screen in the PCSetup Editor. To save the configuration file with a new name, select **File > Save As** and then select "<new>" from the list of file names.

### 2.5.2 Regenerate a Configuration

In the PCSetup Editor, you can edit displays, reports, or Modbus maps using the Display, Report, or Modbus editors. Use the PCSetup Editor to edit assignments, values, and modes of data points. Config600 saves any file modifications in the Config folder and overwrites any previous modifications.

---

**Note:** To regenerate reports, delete the report and add the report using **PCSetup Editor > System Setup > Reports**.

---

The **File > Regenerate** command overwrites all modifications to displays and Modbus maps with the standard displays and Modbus maps as generated at the build time of the configuration. Modifications to the settings and assignments in the configuration file (extension .cfg) are reflected in the regenerated files.

Use the Regenerate command to force configuration setting modifications to the displays and Modbus maps.



**Caution**

**Regenerating a configuration file results in the loss of any custom displays or Modbus maps.**

---

## 2.6 Display Editor

---



Click the Edit Displays icon on the PCSetup tool bar to open the Display Editor. Use it to customize the appearance of displays on the front panel of the S600+. Refer to *Chapter 13, Display Editor*, for complete instructions on using this utility.

---

**Note:** You can also access this utility either by selecting **Tools > Display Editor** from the PCSetup menu bar or by selecting **Start > Config600 3.3 > Display Editor**.

---

## 2.7 Config Transfer Utility

---



Click the Config Transfer icon on the PCSetup tool bar to open the Config Transfer utility. Use it to send new or modified configuration files to the S600+ using either a dedicated serial port or a TCP/IP connection. Config Transfer also enables you to retrieve configuration files from the host PC to the S600+. Refer to *Chapter 9, Config Transfer*, for complete instructions on using this utility.

---

**Note:** You can also access this utility either by selecting **Tools > Transfer** from the PCSetup menu bar or by selecting **Start > Config600 3.3 > Config Transfer**.

---

## 2.8 Config Organiser Utility

---



Use the Config Organiser to arrange the priority of configurations so a certain I/O is read before another, rename or clone I/O modules, streams or stations, and delete I/O modules.



**Caution**

**ALWAYS create a backup of your configuration file before using the Config Organiser. The Config Organiser does not automatically update any LogiCalcs, displays, reports, or Modbus maps.**

---

1. To open the Config Organiser, either:
  - Click the **Config Organiser** icon on the PCSetup Editor's tool bar.
  - Select **Edit > Config Organiser** from the PCSetup Editor's menu bar.

The Config Organiser screen displays:

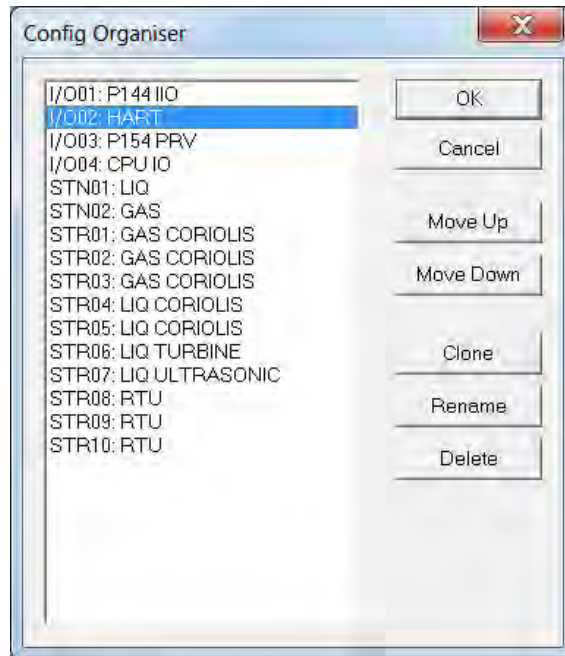

Figure 2-26. Config Organiser

2. Click a button to manage the displayed configuration files

Button	Description
<b>Move Up</b>	Selects an I/O module and moves it to a higher priority in the configuration so a certain I/O is read before another.
<b>Move Down</b>	Selects an I/O module and moves it to a lower priority in the configuration so a certain I/O is read before another.
<b>Clone</b>	Duplicates an I/O module, stream, or station file within the configuration.
<b>Rename</b>	Renames an I/O module, stream, or station to rename that file within the configuration.
<b>Delete</b>	Deletes an I/O module from the configuration.
<b>OK</b>	Applies the indicated changes to the configuration file. <b>Note:</b> Config600 displays a verification dialog box. You must answer Yes to finalise your changes.
<b>Cancel</b>	Cancels the action and closes this window.

*[This page is intentionally left blank.]*

# Chapter 3 – System Setup

## In This Chapter

3.1	Versions.....	3-2
3.2	Units .....	3-3
	3.2.1 Supported Units.....	3-4
3.3	Reports .....	3-6
	3.3.1 General Reports.....	3-7
	3.3.2 Base Time Reports.....	3-8
	3.3.3 Default Reports.....	3-9
	3.3.4 Report History.....	3-9
	3.3.5 Adding a General Report to a Configuration.....	3-9
	3.3.6 User Reports .....	3-11
	3.3.7 Adding a Base Time Report to a Configuration.....	3-11
	3.3.8 Managing Configuration Reports.....	3-13
3.4	Totalisations.....	3-14
3.5	Time .....	3-16

System Setup is the second option in the hierarchy pane on the S600 PCSetup screen. System settings include company details, units of measurement, required reports, and totals. While you define these during the initial configuration process, you can use the System Setup option to edit these values when necessary.

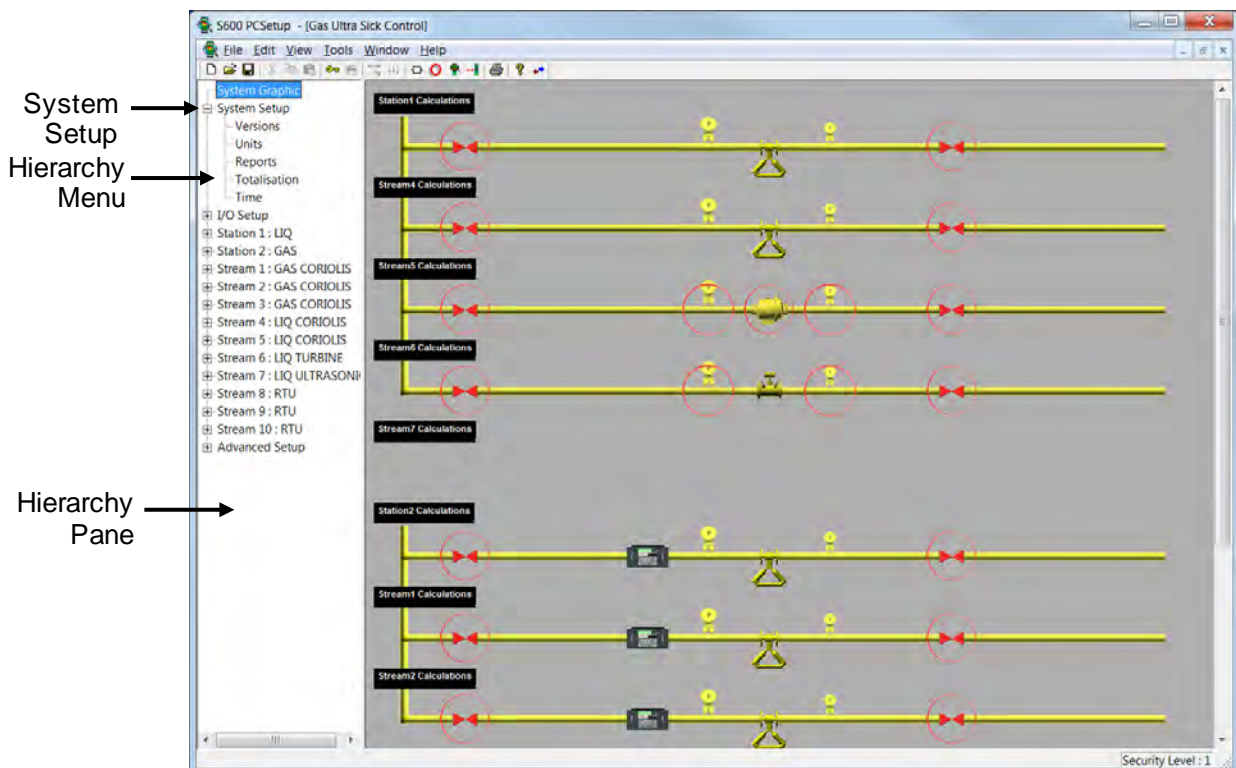

Figure 3-1. System Setup screen

When you double-click **System Setup**, the hierarchy opens to display the sub-options: Versions, Units, Reports, Totalisations, and Time.

### 3.1 Versions

Versions include details of your company and the flow computer being used. Config600 uses this information in webserver access windows.

**Config Format 8** As shown in *Figure 3-2*, Version 3.3 of Config600 uses Config Format 8 for its configuration files. Config Format 8 is designed to work with Release 5.0 of the CPU module (P152).

**Note:** Older configuration files (for release 4.0 or earlier of the CPU module) use Config Format 7. We cannot guarantee that configurations you create using Config Format 8 will work with older releases (4.0 or earlier) of the CPU module.

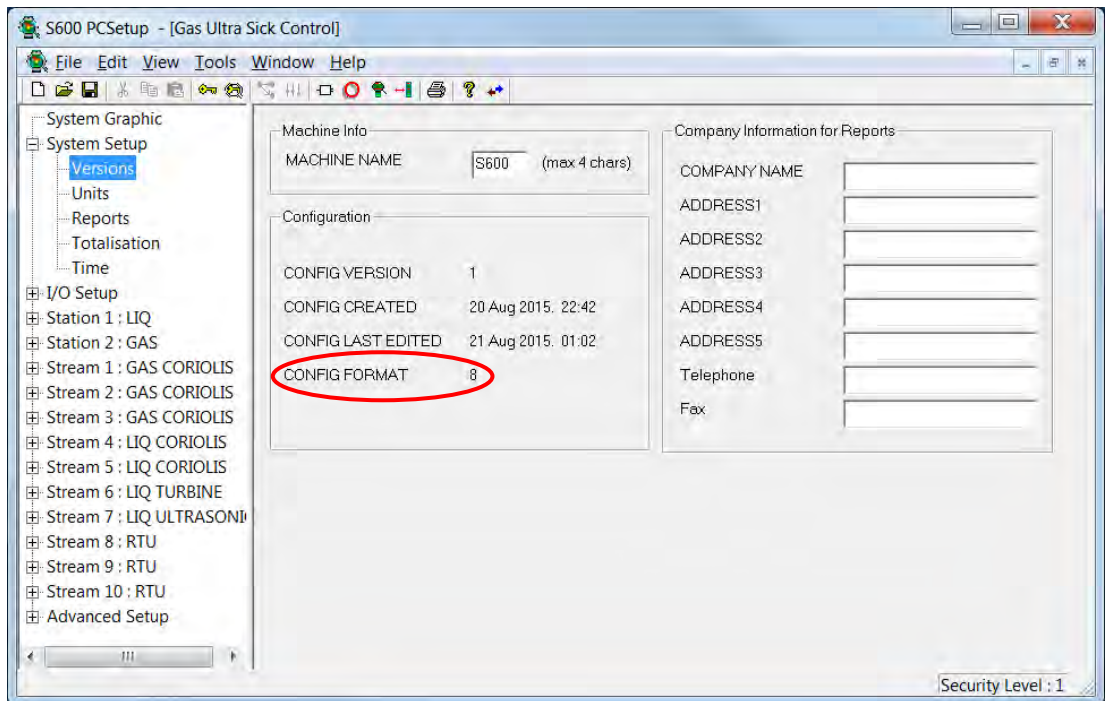

Figure 3-2. Versions screen

When you click **Versions**, Config600 displays a configuration screen in the right-hand pane. Unless otherwise indicated, you can edit the following fields:

Field	Description
<b>Machine Name</b>	Provides a tag number or stream name, up to four characters in length. Config600 uses this tag (such as "S600") on all printed alarms and events.
<b>Company Name</b>	Provides a short description (up to ten alphanumeric characters) for the company.
<b>Address 1 through Address 5</b>	Provides up to five 30-alphanumeric character fields you use to enter your company's address.
<b>Telephone</b>	Provides up to 30 alphanumeric characters for your company's telephone number.
<b>Fax</b>	Provides up to 30 alphanumeric characters for your company's fax number.
<b>Config Version</b>	This <b>read-only</b> field shows the number of times this configuration has been saved since it was created.

Field	Description
<b>Config Created</b>	This <b>read-only</b> field shows the date and time the configuration was originally created.
<b>Config Last Edited</b>	This <b>read-only</b> field displays the date and time the configuration was last saved.
<b>Config Format</b>	This <b>read-only</b> field shows the version number of the template used to create the configuration. <b>Note:</b> Configuration templates are based on the CPU version. Earlier versions (4 or prior) of the CPU module use configuration templates version 7 or earlier; the version 5 CPU module uses the version 8 configuration template. Configurations based on earlier templates function with the new CPU module. However, configurations developed for the new CPU do not work with older CPUs.

**Note:** If you change any values on this screen and try to exit, Config600 displays a dialog box asking to save those changes to your configuration file.

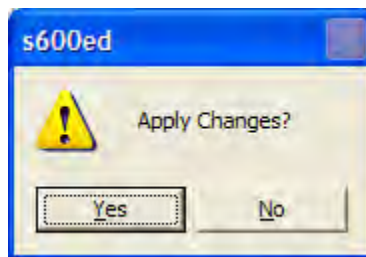

Click **Yes** to apply the changes to your configuration file.

## 3.2 Units

Using the Units options, you define the default standard units of measurement used throughout the configuration. Config600 performs all calculations using units, which conform to the appropriate international standards. However, should the requirements of your application vary, you can change the displayed units of measurement. When you change unit values, the PCSetup Editor automatically performs unit conversions.

You can also override a number of units (such as K-factor) at the stream level.

**Note:** Click **Conversions/Constants** to switch between the Units screen and the Conversions/Constants option in Advanced Setup.

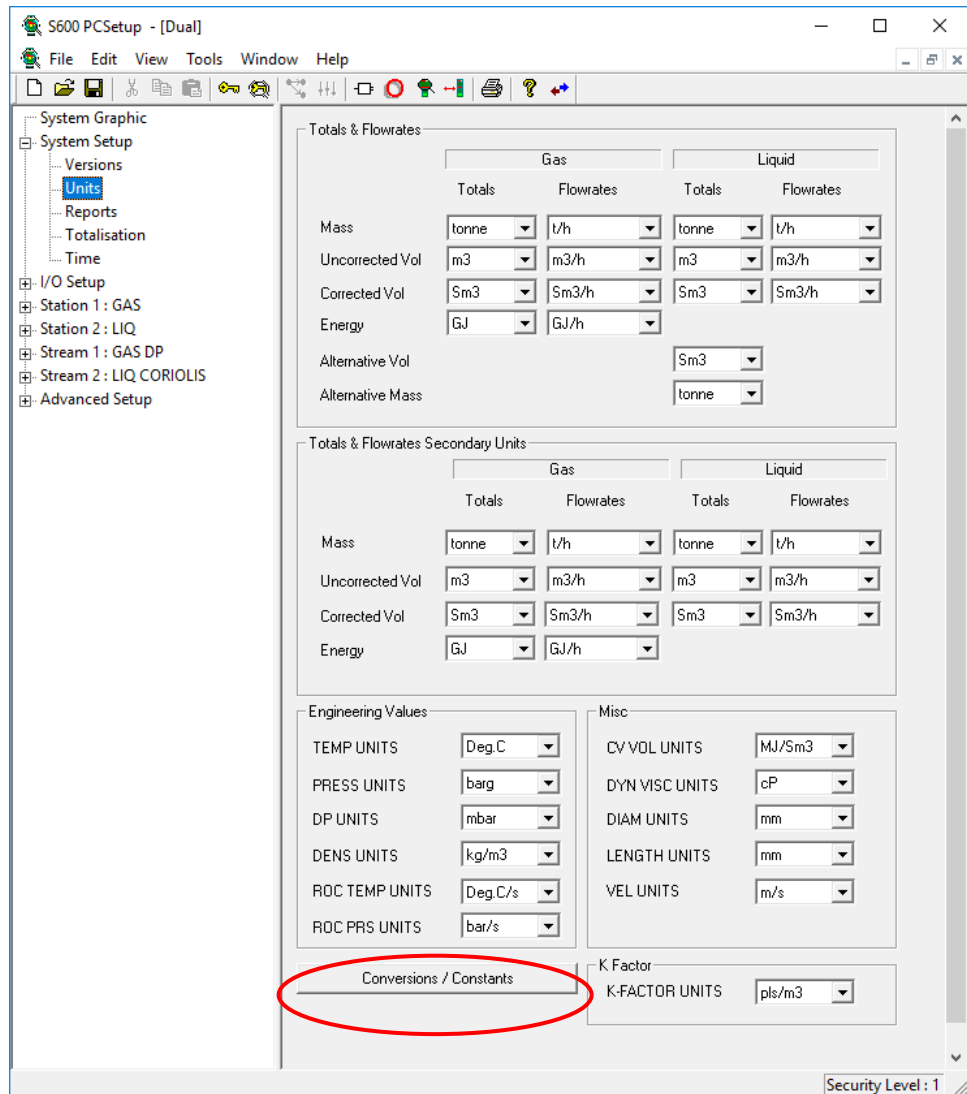
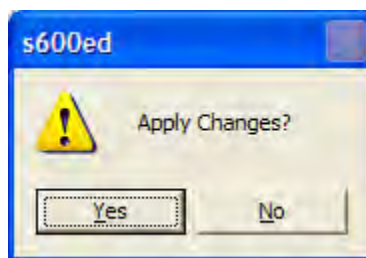

Figure 3-3. Units screen

Each process quantity has a predefined list of selectable units. Click ▼ to select the units preferred for your application. Config600 removes any units not used in this configuration.

**Note:** If you change any values on this screen and try to exit, Config600 displays a dialog box asking to save those changes to your configuration file.



Click **Yes** to apply the changes to your configuration file.

### 3.2.1 Supported Units



Table 3-1 lists the standard units of measurement Config600 supports.

Table 3-1. Standard Measurement Units

Unit Category	Supported Units
<b>Mass</b>	kg, lbs, M.lbs, MM.lbs, tonne, UK.ton, US.ton
<b>Mass Flow Rate</b>	kg/d, kg/h, kg/m, kg/s, lbs/d, lbs/h, M.lbs/d, M.lbs/h, MM.lbs/d, MM.lbs/h, t/d, t/h, UK.t/d, UK.t/h, US.t/d, US.t/h
<b>Uncorrected Vol</b>	bbl, CF, kL, km <sup>3</sup> , L, m <sup>3</sup> , MCF, MMCF, US gal
<b>Uncorrected Vol Flow Rate</b>	bbl/d, bbl/h, CF/d, CF/h, kL/d, kL/h, km <sup>3</sup> /d, km <sup>3</sup> /h, L/d, L/h, L/m, m <sup>3</sup> /d, m <sup>3</sup> /h, MCF/d, MCF/h, MMCF/d, MMCF/h, US.gal/d, US.gal/h
<b>Corrected Vol</b>	MMSCF, MSCF, SbbL, SCF, SkL, Skm <sup>3</sup> , SL, Sm <sup>3</sup> , US.Sgal
<b>Corrected Vol Flow Rate</b>	MMSCF/d, MMSCF/h, MSCF/d, MSCF/h, SbbL/d, SbbL/h, SCF/d, SCF/h, SkL/d, SkL/h, Skm <sup>3</sup> /d, Skm <sup>3</sup> /h, SL/d, SL/h, SL/m, Sm <sup>3</sup> /d, Sm <sup>3</sup> /h, US.Sgal/d, US.Sgal/hr
<b>Energy</b>	Btu, Gcal, GJ, Kkcal, KJ, kW.h, mcal, MJ, MMBtu, MMMBtu, TJ
<b>Energy Flow Rate</b>	Btu/h, Gcal/d, Gcal/h, GJ/d, GJ/h, Kcal/d, Kcal/h, KJ/d, KJ/h, kW.h/d, kW.h/h, MBtu/d, Mcal/d, Mcal/h, MJ/d, MJ/h, MMBtu/d, MMBtu/h, MMMBtu/d, MMMBtu/h, TJ/d, TJ/h
<b>Liquid Alternative Vol</b>	MMSCF, MSCF, SbbL, SCF, SkL, Skm <sup>3</sup> , SL, Sm <sup>3</sup> , US.Sgal
	<b>Notes:</b>
	<ul style="list-style-type: none"> <li>▪ Only used in batching configurations.</li> <li>▪ The conversion between units also compensates for the difference in metric and imperial 'standard' conditions (i.e. m<sup>3</sup> @ 15°C / 0 barg is converted to bbl @ 60F / 0 psig) as per the Aramco standard.</li> </ul>
<b>Liquid Alternative Mass</b>	kg, lbs, M.lbs, MM.lbs, tonne, UK.ton, US.ton
	<b>Note:</b> Only used in batching configurations.
<b>TEMP UNITS (Temperature)</b>	Deg.C, Deg.F, K
<b>PRESS UNITS (Pressure)</b>	bara, barg, kgf/cm <sup>2</sup> a, kgf/cm <sup>2</sup> g, kPa.a, kPa.g, mmH <sub>2</sub> O, mmHg, Mpa.a, MPag, psia, psig
<b>DP UNITS (Differential Pressure)</b>	bar, inH <sub>2</sub> O, Kg/cm <sup>2</sup> , kPa, mbar, Mpa, psi
<b>DENS UNITS (Density)</b>	API, gm/cc, kg/L, kg.m <sup>3</sup> , kg/Sm <sup>3</sup> , lbs/bbl, lbs/CF, SG
<b>ROC TEMP UNITS (Rate of Change, Temperature)</b>	Deg.C/s, Deg.F/s, Deg.K/s
<b>ROC PRESSURE UNITS (Rate of Change, Pressure)</b>	bar/s, kPa/s, psi/s
<b>CV VOL Units (Calorific Value)</b>	BTU/lb, BTU/SCF, GJ/kg, GJ/Sm <sup>3</sup> , kcal/m <sup>3</sup> , kW.h/m <sup>3</sup> , MJ/kg, MJ/Sm <sup>3</sup>
<b>DYN VISC UNITS (Dynamic Viscosity)</b>	cP, lbm/ft.s, mPa.s, Pa.s, uPa.s

Unit Category	Supported Units
<b>DIAM UNITS (Diameter)</b>	cm, ft, in, m, mm, yd
<b>LENGTH UNITS</b>	cm, ft, in, m, mm, yd
<b>VEL UNITS (Velocity)</b>	ft/s , m/s
<b>K factor</b>	pls/bbl, pls/CF, pls/kg, pls/L, pls/lbs, pls/M.lbs, pls/MM.lbs, pls/m3, pls/tonne, pls/US.gal, pls/US.ton

### 3.3 Reports

Click the Reports option to display a screen identifying the reports currently associated with your configuration (*Figure 3-4*). Config600 provides two report categories, General and Base Time.

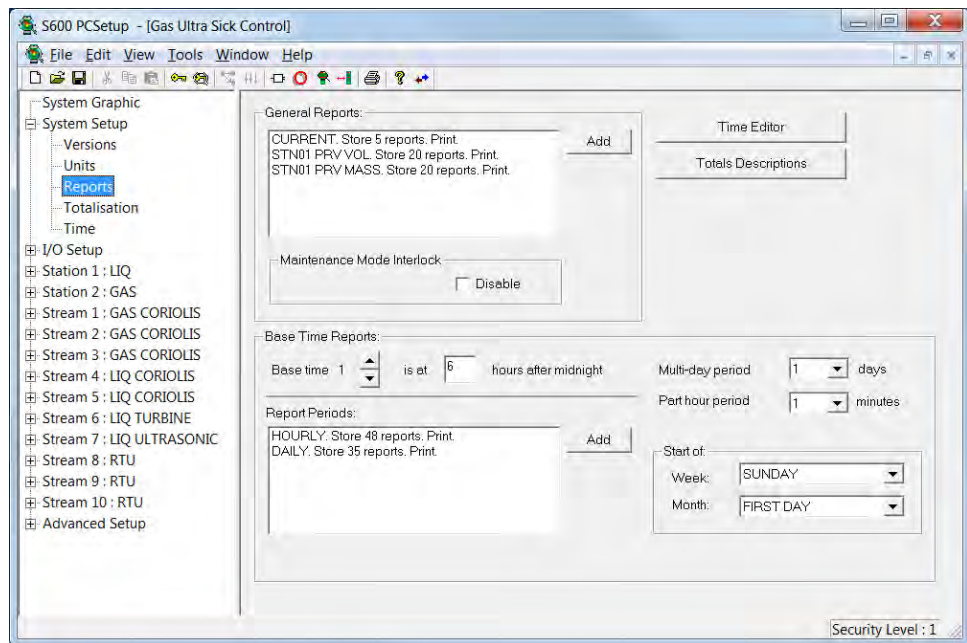

Figure 3-4. Reports screen

Field	Description
<b>General Reports</b>	Displays the general reports available for selection.
<b>Add</b>	Click to add a new report.
<b>Configure</b>	Click to configure the selected report.
<b>Edit</b>	Click to edit the selected report using the Report Editor.
<b>Delete</b>	Click to delete the selected report.
<b>Maintenance Mode Interlock</b>	Enables the system to access turbine mode, DP mode, and densitometer information regardless of the Maintenance Mode status. By default, Config600 selects this option for imperial-based configurations but <b>does not</b> select this option for metric configurations.
<b>Time Editor</b>	Click to display the <b>System Setup &gt; Time</b> screen you use to configure time and data parameters for the selected report.
<b>Totals Descriptions</b>	Click to display the the <b>Advanced Setup &gt; Total Descriptions</b> screen you use to configure descriptions for the selected report.

Field	Description
<b>Base Time</b>	Click ▲ or ▼ to select the base time for which you want to add a report. <b>Note:</b> Although you can define three sets of base time reports, Config600 reserves the Hourly and Daily reports in base time 2 for Electronic Flow Management (EFM) reports (if an EFM Modbus module link is included in the software). You can overwrite these values, but it may eliminate your ability to generate EFM reports.
<b>Hours after midnight</b>	Sets the beginning hour for the specified base time. <b>6</b> is the default hour.
<b>Multi-day periods</b>	Selects how many days a report should cover. Click ▼ to display valid values. <b>1</b> is the default. <b>Note:</b> Once you set this value, the system uses this as a fixed period across all three Base Times. For example, you cannot then change a period of 10 days to a period of 5 days for Base Time 2.
<b>Part hour period</b>	Indicates how many minutes apart you want reports to generate. Click ▼ to display valid values. <b>1</b> is the default. <b>Note:</b> Once you set this value, the system uses this as a fixed period across all three Base Times. For example, you cannot then change a period of 10 minutes to a period of 5 minutes for Base Time 2.
<b>Report Periods</b>	Displays the current report periods associated with the report you select in the General Reports pane. <b>Add</b> Click to add a new report period. <b>Configure</b> Click to configure the selected report period. <b>Note:</b> This button does not display until you select a report period. <b>Edit</b> Click to edit the report period you selected in the Reports Editor. <b>Note:</b> This button does not display until you select a report period. <b>Delete</b> Click to delete the selected report. <b>Note:</b> This button does not display until you select a report period.
<b>Start of</b>	Indicates when the report period starts.
<b>Week</b>	Indicates the weekday on which the report period starts. Click ▼ to display valid values. The default is <b>Sunday</b> .
<b>Month</b>	Indicates the day of the month on which the report period starts. Valid values are <b>Last Day</b> and <b>First Day</b> . The default is <b>First Day</b> .

### 3.3.1 General Reports

General reports, which generate as a result of some exception event, include:

Report Name	Definition
<b>Batch</b>	Shows totals at the start and end of the batch.

<b>Current</b>	Shows the current flow rate and cumulative totals. <b>Note:</b> You can request this report from the S600+ front panel or webserver.
<b>Maint</b>	Shows totals as you enter and exit maintenance mode.
<b>STN01 Prv Vol and STN02 Prv Vol</b>	Reserved for prover configurations; summarises trial runs and final volume data for a prove run.
<b>STN01 Prv Mass and STN02 Prv Mass</b>	Reserved for prover configurations; summarises trial runs and final mass data for a prove run.
<b>CHR D/Load</b>	Generates when the chromatograph download data changes or when a timeout or mode change occurs.
<b>CHR Telemetry</b>	Generates on the receipt of a new analysis from the chromatograph.
<b>Batch Ticket</b>	Shows totals and batch details at the start and end of the batch. It also generates if a batch recalculation occurs. <b>Note:</b> This report replaces the Batch report.
<b>Basetime x Tab Daily</b>	Provides the daily data (from the basetime x hourly reports) in a tabular format. Available for basetimes 1, 2, and 3.
<b>Basetime x Tab Monthly</b>	Provides the monthly data (from the basetime x daily reports) in a tabular format. Available for basetimes 1, 2, and 3.
<b>User-defined</b>	9 reports with content you define.

**Note:** If you import older configuration files into Config600, the Compact Hourly report option may appear on this listing. This report, a system-generated base time Hourly report, is available but no longer supported.

### 3.3.2 Base Time Reports

Base time reports provide system data as of a particular hour (base time) you define. Base time reports include:

<b>Time</b>	<b>Definition</b>
<b>Hourly</b>	Shows throughput for the previous hour.
<b>2 Hourly</b>	Shows throughput for the previous two hours.
<b>3 Hourly</b>	Shows throughput for the previous three hours.
<b>4 Hourly</b>	Shows throughput for the previous four hours.
<b>6 Hourly</b>	Shows throughput for the previous six hours.
<b>8 Hourly</b>	Shows throughput for the previous eight hours.
<b>12 Hourly</b>	Shows throughput for the previous twelve hours.
<b>Daily</b>	Shows throughput for the previous day.
<b>Weekly</b>	Shows throughput for the previous week.
<b>Monthly</b>	Shows throughput for the previous month.
<b>Batch Hourly</b>	Shows, for each hour during a batch, the batch hourly total and the batch total. <b>Note:</b> Config600 generates this report only during batches. If a batch finishes midway through an hour, Config600 <b>does not</b> generate the batch hourly value for that hour but <b>does</b> generate the end-of-batch value that contains totals for that batch.
<b>Multi Day</b>	Shows throughput for the previous multi-day period, as

Time	Definition
	defined in the Multi-day period field. <b>Note:</b> Once you set this value, the system uses this as a fixed period across all three Base Times. For example, you cannot then change a period of 10 days to a period of 5 days for Base Time 2.
<b>Part Hour</b>	Shows throughput for previous part-hour period, as defined in the Part hour period field. <b>Note:</b> Once you set this value, the system uses this as a fixed period across all three Base Times. For example, you cannot then change a period of 10 minutes to a period of 5 minutes for Base Time 2.

---

**Note:** Although Config600 provides up to three base time categories for reports, Config600 reserves base time 2 for Electronic Flow Measurement (EFM) reports, which typically do not print. Refer to *Chapter 14, Modbus Editor*, for further information.

---

### 3.3.3 Default Reports

Config600 provides five default reports:

- **General Reports:** Current (set to print and store five instances).
- **Base Time 1 Reports:**
  - **Hourly** (set to print and store 24 instances of this report).
  - **Daily** (set to print and store 35 instances of this report).
- **Base Time 2 Reports (reserved for EFM reports):**
  - **Hourly** (set to store 840 instances of this report).
  - **Daily** (set to store 35 instances of this report).

### 3.3.4 Report History

The S600+ saves all periodic reports in circular buffers. For example, you decide to save five instances of that report. After saving those five reports and generating reports 6 and 7, the S600+ then overwrites the data for reports 1 and 2. How many reports you can save is a function of the available memory on the S600+. Refer to *Section 3.3.5, Adding a General Report to a Configuration* for information on the total number of reports you can save.

---

**Note:** If necessary, you can use the Report Editor to change the report format. Any data existing in Config600 is available for inclusion on a report, and you can change a report's format at any time.

---

### 3.3.5 Adding a General Report to a Configuration

---

**Note:** Refer to *Appendix H, CFX Reporting*, for more information on CFX reports.

---

Use this procedure to add a General report to your configuration file.

1. Click **Add** in the General Reports pane. The Archive Configuration dialog box displays:

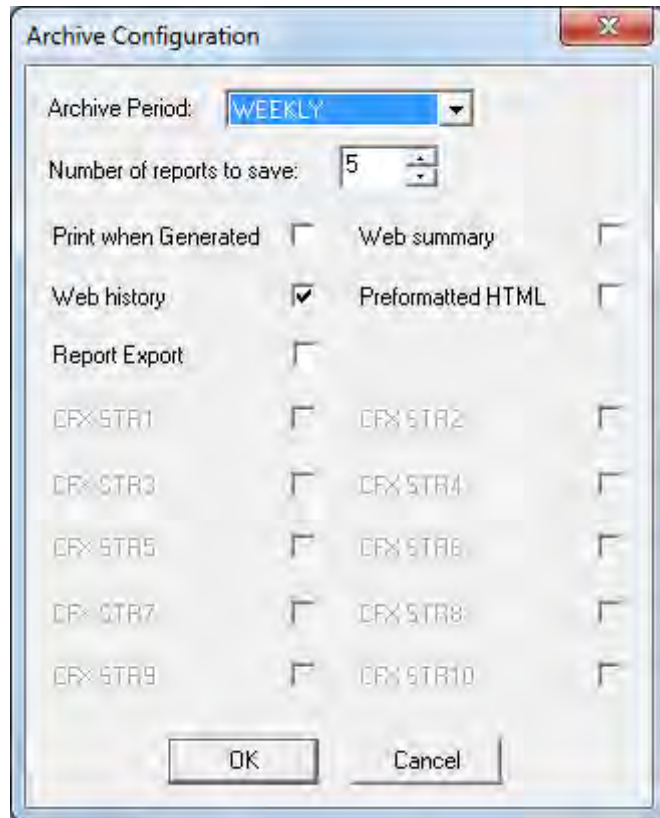

Figure 3-5. Archive Configuration dialog box

2. Complete the following values:

Field	Description
<b>Archive Period</b>	Indicates the General reports available for selection. Click ▼ to display the reports for selection. <b>Note:</b> When you select a report from this list and add it to the configuration file, Config600 removes that report name from this listing.
<b>Number of reports to save</b>	Indicates the number of instances of this report to save. Click ▲ or ▼ to increase or decrease the displayed value. <b>Note:</b> The total number of reports you can save is a function of the available storage on the S600+ after you create a configuration file and cold start it. Config600 also uses a “report buffer” to store reports. If you select <b>5</b> , Config600 overwrites the first iteration of the generated report with the sixth.
<b>Print when Generated</b>	Indicates whether Config600 prints the report after generating it.
<b>Web history</b>	Indicates whether the selected report appears as an option in the Reports display on the S600+ Webserver.
<b>Report Export</b>	Exports the report formatted as either a text file or a CSV file to a location you specify.
<b>Web summary</b>	Indicates whether Config600 includes report data “live” as part of the webserver menu bar.
<b>Preformatted HTML</b>	Indicates whether Config600 uses its native HTML formatting when displaying webserver-based reports or

Field	Description
	uses your HTML formatting. Select this option to use your HTML formatting for reports. <b>Note:</b> This is an advanced option. Contact Technical Support for further information.

- Click **OK** when you are finished. The Archive Configuration dialog box closes. Config600 adds your report to the General Reports listing.

### 3.3.6 User Reports

S600+ also provides 9 user-defined reports (USER31 through USER39) in the General Reports category. Use these reports when you have developed special programs (such as a LogiCalc) to trigger report conditions or desire to use them on the webserver. You can also use these reports to add your own displays on the Webserver menu bar.

---

**Note:** The disable form feed function **is not** available with user reports.

---

### 3.3.7 Adding a Base Time Report to a Configuration

Use this procedure to add a base time report to your configuration file.

- Click ▲ or ▼ in the Base Time Reports pane of the Report screen to select the base time for which you want to add a report.

---

**Note:** Although you can define three sets of base time reports, Config600 reserves the Hourly and Daily reports in base time 2 for Electronic Flow Management (EFM) reports (if an EFM Modbus module link is included in the software). You can overwrite these values, but it may eliminate your ability to generate EFM reports.

---

- Complete the **hours after midnight** field to indicate the beginning hour for the selected base time.

- Click **Add** in the General Reports pane. The Archive Configuration dialog box displays:

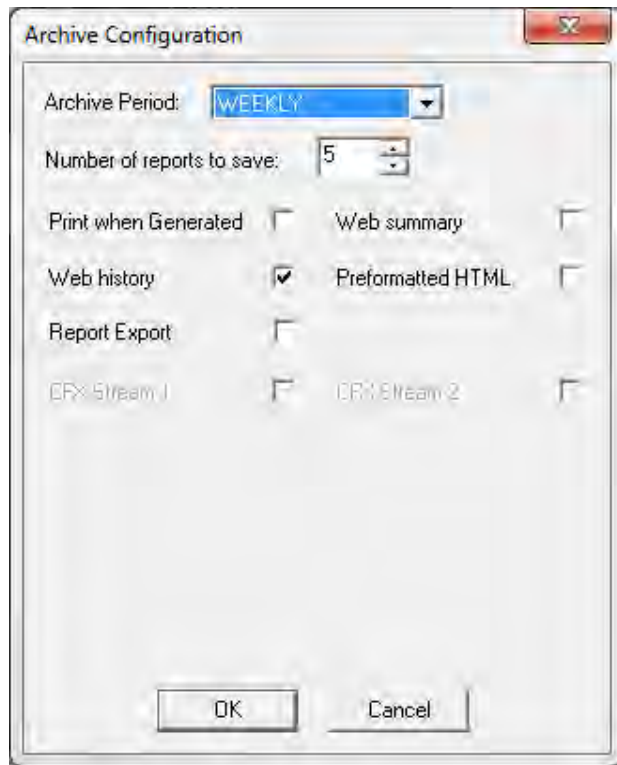

Figure 3-6. Archive Configuration

- Complete the following values:

Field	Description
<b>Archive Period</b>	Displays the base time reports available for selection. Click ▼ to display the reports you can select. <b>Note:</b> When you select a report from this list and add it to the configuration file, Config600 removes that report name from this listing.
<b>Number of reports to save</b>	Indicates the number of instances of this report to save. <b>Note:</b> The total number of reports you can save is a function of the available storage on the S600. Config600 also uses a “report buffer” to store reports. For example, if you select 5, Config600 overwrites the first iteration of the generated report with the sixth.
<b>Print when Generated</b>	Indicates whether Config600 prints the report after generating it.
<b>Web history</b>	Indicates whether the selected report appears as an option in the Reports display on the Config600 webserver.
<b>Report Export</b>	Exports the report formatted as either a text file or a CSV file to a location you specify.
<b>Web summary</b>	Indicates whether Config600 includes report data “live” as part of the webserver menu bar.
<b>Preformatted HTML</b>	Indicates whether Config600 uses its native HTML formatting when displaying webserver-based reports or your HTML formatting. Select this box to use your HTML formatting for reports. <b>Note:</b> This is an advanced option. Contact Technical Support for further information.



Field	Description
<b>CFX Stream X</b>	Indicates whether Config600 generates a CFX report for this stream. For more information on CFX reports, refer to <i>Appendix H, CFX Reporting</i> .

- Click **OK** when you finish. The Archive Configuration dialog box closes. Config600 adds your report to the Base Time Reports listing.
- Complete the following fields if you added these reports:

Report	Field
<b>Daily</b>	Indicates the beginning day of the week. Click ▲ or ▼ to select a day. The default is <b>Sunday</b> .
<b>Monthly</b>	Indicates whether the month “starts” on the last day of the current month (Last Day or March 31) or the first day of the next month (First Day or April 1). Click ▲ or ▼ to select a value. The default is <b>First Day</b> .

### 3.3.8 Managing Configuration Reports

At any time you can manage—edit, delete, or reconfigure—the reports you have added to your configuration file. Click on a report and Config600 displays three additional buttons.

- Click **Configure** to display the Archive Configuration dialog box.
- Click **Edit** to access the Report Editor (*Chapter 10*).
- Click **Delete** to remove the defined report from the configuration file.

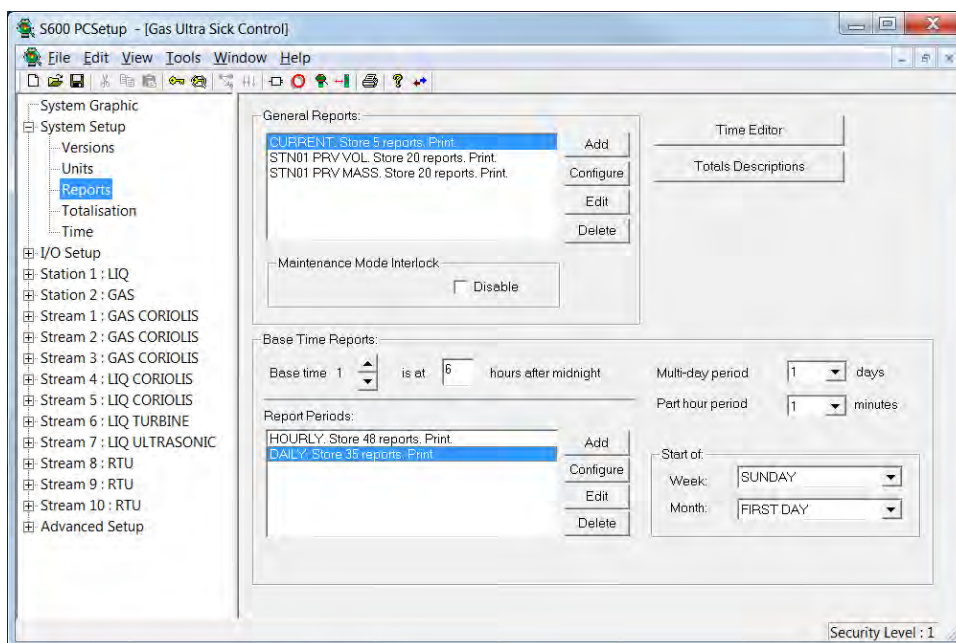
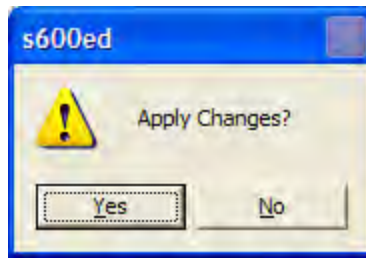

Figure 3-7. Managing Configurations

**Note:** If you change any values on this screen and try to exit, Config600 displays a dialog box asking to save those changes to your configuration file.



Click **Yes** to apply the changes to your configuration file.

### 3.4 Totalisations

Click the **Totalisation** option on the hierarchy to display the Totalisation screen (*Figure 3-8*). Use this screen to manage how the system displays totals.

The Totalisation screen has three components: a Totals Resolutions pane, a Total Rollover Digit field, and an Increment Cumulatives in Maintenance Mode check box. Edit the Totals Resolution values using a dialog (*Figure 3-9*). For example, if you set the Rollover value to 7 and the Decimal Place value to 3, rollover occurs at 9,999,999.999. Similarly, if you set Rollover to 4 and Decimal Place to 2, rollover occurs at 9,999.99.

**Notes:**

- The main calculation routines always use full double-precision accuracy for all totalisers and maintain accuracy internally, even if you select a restricted number of decimal places for display and reporting.
- Base Sediment and Water volumes use Standard Volume Units. This is true even when they are computed as gross volumes.

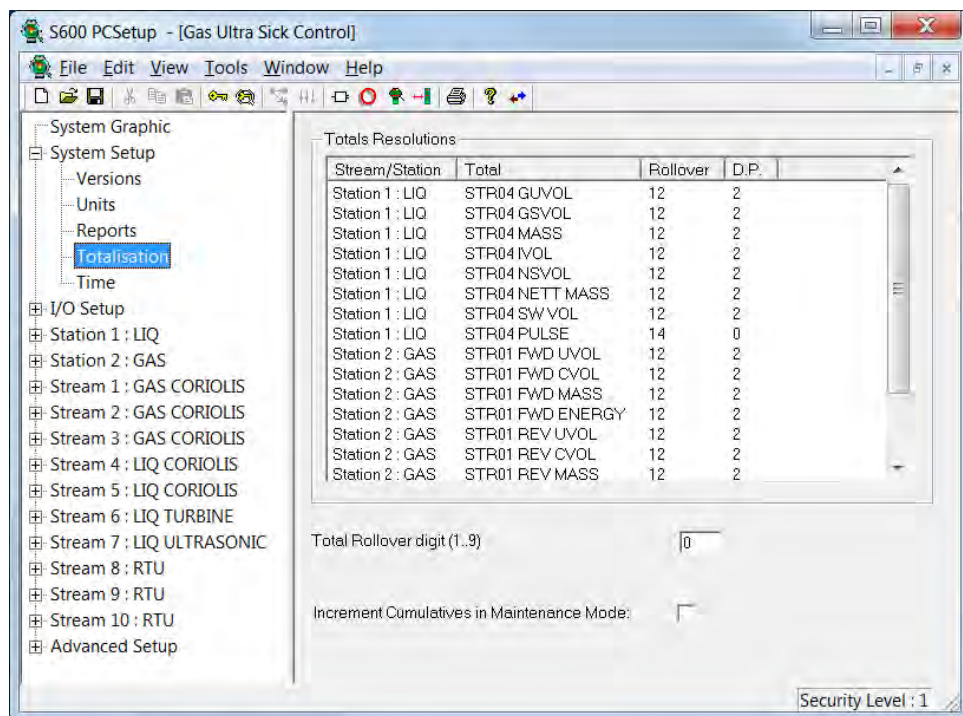

Figure 3-8. Totalisation

To edit totals:

1. Double-click a **Station/Stream** line in the Totals Resolution pane. The Totals Detail dialog displays:

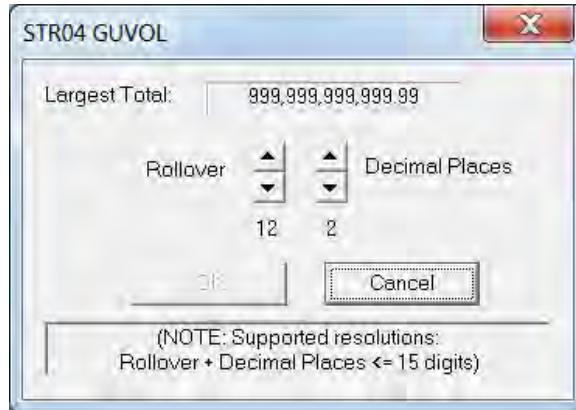

Figure 3-9. Totals Detail dialog

2. Complete the following values:

Field	Description
<b>Largest Total</b>	This <b>read-only</b> field shows the total's current format. The system changes this display as you modify the Rollover and Decimal Places values. <b>Note:</b> No total can have more than 15 digits.
<b>Rollover</b>	Indicates the maximum number of digits in the total before it rolls over to zero. Valid values are <b>3</b> to <b>15</b> . The default is <b>12</b> . Click ▲ or ▼ to increase or decrease the total number of digits. <b>Note:</b> Set this value to ensure that when a stream flows at its maximum possible flow rate, this limit would not cause the total to roll over to zero within a 24-hour period. Typically, leave the value at its default of 12 digits.
<b>Decimal Places</b>	Indicates the number of decimal places in the total. Valid values are <b>0</b> to <b>5</b> . The default is <b>2</b> . Click ▲ or ▼ to increase or decrease the total number of decimal places.

3. Complete the **Total Rollover digit** field (see Figure 3-8) to indicate the value at which rollover occurs. For example, if you either leave this field at **0** (default) or set it to **9**, rollover occurs at 9,999. If you set this field to **3**, rollover occurs at 3,999, and so on.
4. Select the **Increment Cumulatives in Maintenance Mode** check box (see Figure 3-8. *Totalisation*) to enable the S600+ to increment all totals in maintenance mode. Otherwise the S600+ increments only Maintenance Mode totals when in maintenance mode.

---

**Note:** If you change any values on this screen and try to exit, Config600 displays a dialog asking to save those changes to your configuration file.

---

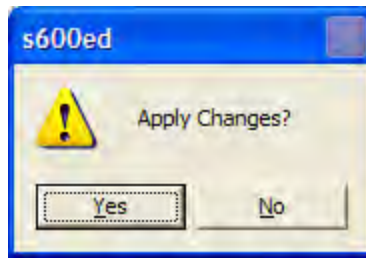

Click **Yes** to apply the changes to your configuration file.

### 3.5 Time

Click the Time option on the hierarchy to display the Date/Time Parameters screen (*Figure 3-10*) and to manage how the system formats dates and displays time. The FloBoss S600+ provides two methods for time synchronisation: via NTP (refer to section 4.10 Communications Port) and via a supervisory system.

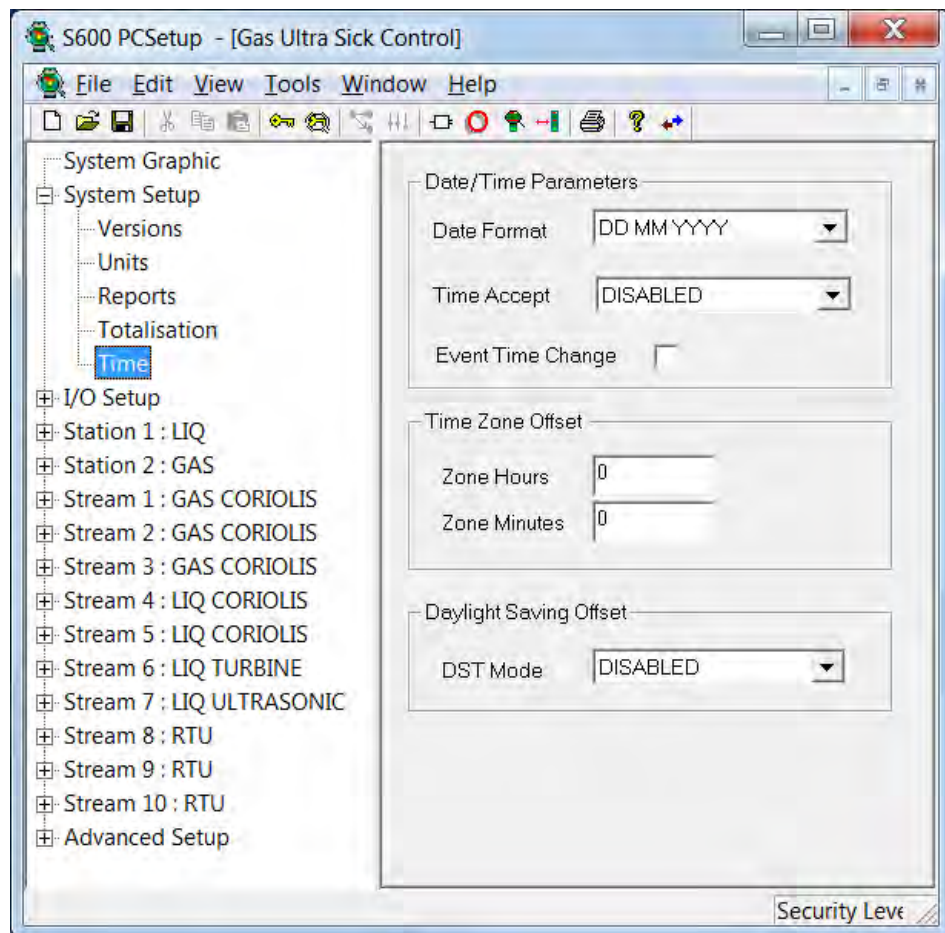

*Figure 3-10. Date/Time Parameters*

1. Review the **Date Format**, which S600+ uses when displaying dates throughout the system. Click ▼ to display available format options. The default format is **DD MM YYYY**.
2. Review the **Time Accept** value, which S600+ uses to perform time synchronisation procedures for a supervisory system. Valid values are:

- **Disabled**

No time synchronisation is performed via the supervisory computer. The default is **Disabled**.

- **Automatic**

Time synchronisation is automatically performed whenever there is a change in the time or date downloaded from the supervisory computer. This requires the configuration of the SYSTEM KPINTARR TIME AND DATE (DLOAD fields) in the supervisory Modbus Map. When a change is seen in any of these fields (DLOAD YEAR, DLOAD MONTH, DLOAD DAY, DLOAD HOUR, DLOAD MINUTE, DLOAD SECOND), the FloBoss S600+ immediately sets its internal clock to these values.

It is also possible to configure the FloBoss S600+ to synchronize the time when requested to do so by the supervisory computer. This method allows the supervisory computer to download the new time / date before it is needed (at least 30 seconds in advance) and the synchronization is then triggered when required. This triggering is done by using the SYSTEM KPINT DLOAD TIME ACCEPT parameter. When this field is set to 1 the FloBoss S600+ immediately sets its internal clock to the values previously defined in the DLOAD YEAR, DLOAD MONTH, DLOAD DAY, DLOAD HOUR, DLOAD MINUTE, DLOAD SECOND fields.

To compensate for any delays in the communications link, a DLOAD OFFSET value is provided (in seconds). If this is non-zero then the value is added to the required time (For example if the DLOAD SECOND is set to 30 and the DLOAD OFFSET is set to 10, then the FloBoss S600+ will set its seconds value to 40).

More information on time synchronisation via Modbus can be located in document “How To 61” (which can be obtained by contacting Technical Support).

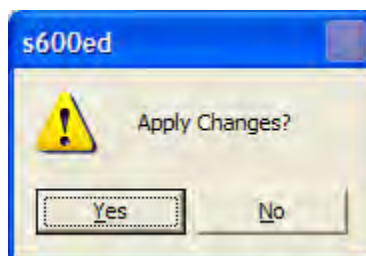

3. Select the **Event Time Change** option to raise an event whenever you change the system time using Modbus.
4. Enter the **Zone Hours** and **Zone Minutes** in the Time Zone Offset pane to set the local time. Local time in each time zone is GMT plus the current time zone offset (hours/minutes) for the location.

---

**Note:** If time synchronization is being performed by a public NTP server, then the Zone Hours / Zone Minutes fields need to be updated to reflect the time difference from UTC. This ensures the flow computer time is correct for its location. (Public NTP servers send their time as UTC and the configured Zone Hours / Zone Minutes are added or subtracted).

---

5. Click ▼ in the **DST Mode** field to select the type of Daylight Savings Time to use. Valid values are:
  - **Disabled**  
Uses Daylight Savings Time as set on your computer.
  - **Europe**  
Calculates DST as outlined in COM(2000)302 final, 2000/0140(COD), “Directive of the European Parliament and of the Council on Summer Time Arrangements.”
    - For the purposes of this Directive “summer time period” shall mean the period of the year during which clocks are put forward by 60 minutes compared with the rest of the year.
    - From 2002 onwards, the summer time period shall begin, in every Member State, at 1:00 a.m., Greenwich Mean Time, on the last Sunday in March.
    - From 2002 onwards, the summer time period shall end, in every Member State, at 1:00 a.m., Greenwich Mean Time, on the last Sunday in October.
6. It is possible to provide a Daylight Saving Time status flag which indicates Winter Time (value = 0) or Summer Time (value = 1). This is only possible by use of the System Editor. Please contact Technical support for a ‘How To’ document if this feature is required.

---

**Note:** System Editor is available only with the Config600 Pro software.

---

7. Click **Yes** to apply the changes to your configuration file.

## Chapter 4 – I/O and Comms Configuration

### In This Chapter

4.1	Discrete (Digital) Inputs (DI).....	4-2
4.1.1	Assigning Discrete (Digital) Outputs.....	4-2
4.1.2	Editing Discrete (Digital) Outputs.....	4-3
4.1.3	Adding Discrete (Digital) Outputs .....	4-4
4.2	Discrete (Digital) Outputs (DO).....	4-5
4.2.1	Assigning Discrete (Digital) Outputs.....	4-5
4.3	Analog Inputs (AI).....	4-6
4.3.1	Assigning Analog Inputs (AI) .....	4-6
4.3.2	Editing Analog Inputs (AI) .....	4-7
4.3.3	Adding a New I/O Point .....	4-15
4.4	Analog Outputs (AO).....	4-15
4.4.1	Editing Analog Outputs.....	4-15
4.5	Density Inputs .....	4-17
4.5.1	Assigning Density Input.....	4-17
4.5.2	Editing Density Inputs.....	4-18
4.6	Turbine Inputs.....	4-19
4.6.1	Assigning Turbine Inputs .....	4-19
4.6.2	Editing Turbine Inputs .....	4-21
4.7	Pulse Outputs .....	4-21
4.7.1	Assigning Pulse Outputs.....	4-22
4.8	HART Modules.....	4-22
4.8.1	Editing HART Settings.....	4-23
4.9	PID Loop Settings.....	4-23
4.9.1	Assigning PID Loops.....	4-24
4.9.2	Proportional Plus Integral and Derivative Action .....	4-28
4.10	Communications Port .....	4-30
4.10.1	Editing a Communications Task.....	4-30
4.10.2	Setting Up Peer-to-peer Options.....	4-35

The configuration process assigns default I/O channels to all input and output data items—including analog input and digital (discrete) input signals, turbine inputs, Highway Addressable Remote Transducer (HART®) transmitters, and communication tasks—the S600+ uses.

Using the I/O Setup option in PCSetup Editor, you can change an assigned channel, unassign channels, and modify settings for your configured channels. You can also modify the communication tasks, including allocating communications links and defining serial port settings. Refer to *Figure 4-1* for a sample screen. Note that some items have already been assigned values.

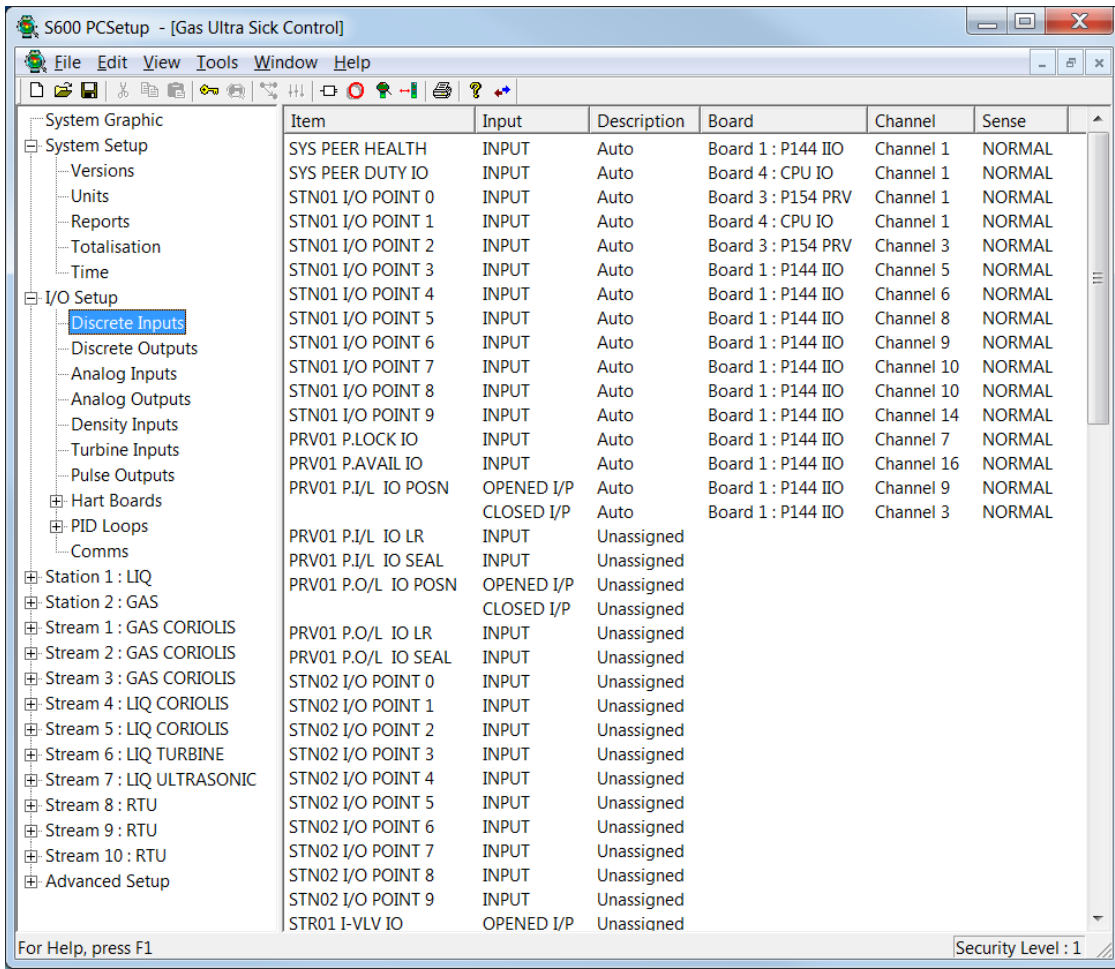

Figure 4-1. Typical I/O Setup Screen (Discrete Inputs Shown)

## 4.1 Discrete (Digital) Inputs (DI)

You can assign each of the data items to a specific digital input channel on an available I/O module. You can also configure additional user-defined inputs for extra signals, if required.

Each I/O module (P144 I/O) you install provides up to 16 digital input channels. Each Prover module (P154 PRV) you install provides up to 32 digital input channels. The CPU module (CPU I/O) provides one digital input channel.

### 4.1.1 Assigning Discrete (Digital) Inputs

To assign or reassign digital input data items:

1. Select **Digital Inputs** from the hierarchy menu.
2. Double-click the digital input you desire to edit. The Digital Input Selection dialog box displays.

**Note:** You can also click the Assignment icon  on the toolbar to display the dialog box.



3. Select the **I/O Board** to assign the digital input or select **Unassigned** to deselect the input. Config600 completes the I/O Channel field with available channels:

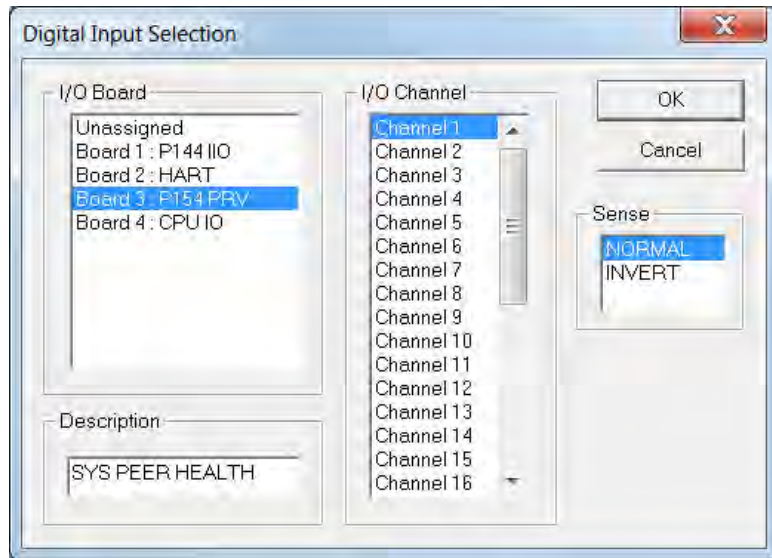

Figure 4-2. Digital Input Selection dialog box

4. Select an **I/O Channel**.
5. Select the **Sense** for the digital input bit. The default is **Normal**. **Invert** reverses the signal's state.
6. Click **OK** to apply the new assignment. The PCSetup screen displays showing your new assignment.

---

**Note:** The PCSetup Editor displays a warning message if you assign the I/O channel to more than one digital input. Use **caution:** the PCSetup Editor displays a message but **does not** prevent you from assigning the input more than once.

---

## 4.1.2 Editing Discrete (Digital) Inputs

To edit the description for a digital input data item:

1. Right-click the data item. The system displays a shortcut menu.

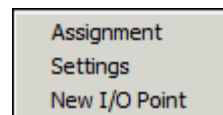

---

**Note:** You can also click the Settings icon  on the toolbar after highlighting the data item to display the menu. However, if this option is not available for this item, the system greys out this icon.

---

2. Select **Settings** on the menu. The Edit Descriptions dialog box displays:



Figure 4-3. Edit Description dialog box

3. Edit the current description or enter a new description.

---

**Note:** The S600+ does not pass this value to the Config600 configuration or display. Use this process **only** to customize or clarify the value on this screen.

---

4. Click **OK** to confirm the change. The PCSetup screen displays showing the edited label.

### 4.1.3 Adding Discrete (Digital) Inputs

To add an additional data item:

---

**Note:** When you add a digital I/O point, the point is an object that is capable of using 16 digital inputs to derive its value. This means that a single object can have a value between 0 and 65535 as its decimal equivalent. This value shows as 16 bits in the Digital Inputs list.

---

1. Right-click in the right pane. A shortcut menu displays.

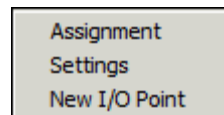

2. Select **New I/O Point** from the shortcut menu. The Digital Input Selection dialog box displays:

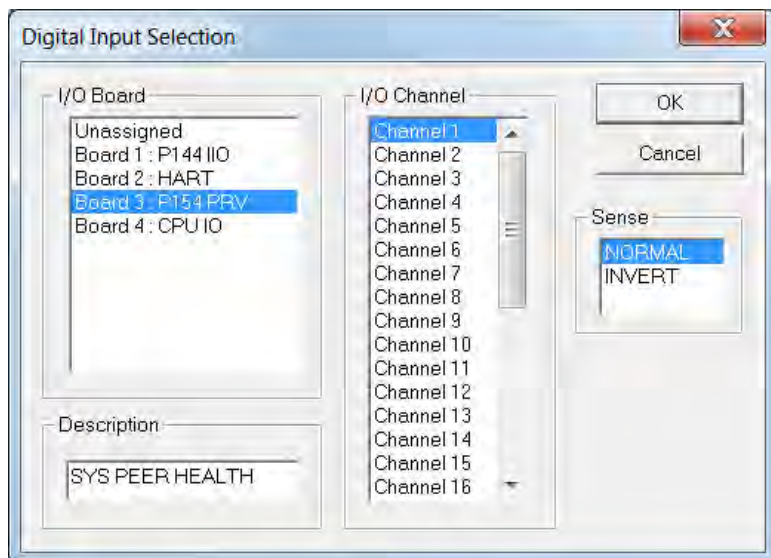

Figure 4-4. Digital Input Selection (New I/O Point)

**Note:** The Description field on this screen contains **USER**, indicating that this I/O point is user-defined.

3. Select the **I/O Board** to assign the digital input (or select **Unassigned** to deselect the input).
4. Select an I/O Channel.
5. Select the **Sense** for the digital input bit. The default is **Normal**. **Invert** reverses the signal's state.
6. Click **OK** to apply the new assignment. The PCSetup screen displays showing your new assignment.

## 4.2 Discrete (Digital) Outputs (DO)

You can assign each digital output channel to an individual data item. Additionally, the S600+ allows you to assign data items to more than one output, making a repeat signal available, if necessary.

Up to 12 digital output channels are available on each installed I/O (P144) module, and up to 12 digital output channels are available on each installed Prover (P154) module.

### 4.2.1 Assigning Discrete (Digital) Outputs

To assign or reassign a digital output data item:

1. Select **Digital Outputs** from the hierarchy menu.
2. Double-click on a digital output item to edit. The Digital Output Selection dialog box displays.
3. Select the **Item** to assign the digital output or select Unassigned to deselect the output. Config600 completes the Output field with applicable values (such as Output or Open):

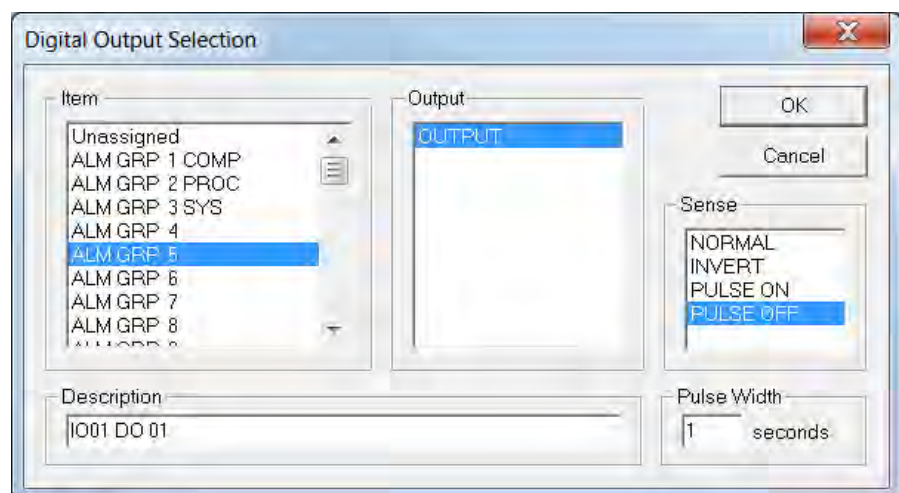

Figure 4-5. Digital Output Selection dialog box

4. Select an **Output** channel.
5. Select the **Sense** for the digital output. Valid values are **Normal**, **Invert**, **Pulse On**, or **Pulse Off**. The default is **Normal**.

**Note:** If you select either Pulse On or Pulse Off, you must also provide a pulse width (a minimum of 1 second) in the **Pulse Width** field.

6. Click **OK** to confirm the reassignment. The PCSetup screen displays showing the reassigned values.

### 4.3 Analog Inputs (AI)

You can assign each displayed data item to a specific Analog or PRT (Platinum Resistance Thermometer)/RTD (Resistance Temperature Detector) input channel on the I/O module (P144) or the HART module (P188).

Each installed I/O module provides up to 12 analog input channels and three PRT/RTD input channels. The Prover module (P154) does not have any available analog or PRT/RTD input channels. The HART module supports up to 50 transmitters.

**Note:** If the densitometer also acts as the temperature element for the meter, you assign both the Meter Temperature and Densitometer Temperature to the same analog input. If the prover has only one temperature element, you assign both inlet and outlet temperature to the same analog input. This also applies to the pressure transmitter.

#### 4.3.1 Assigning Analog Inputs (AI)

To assign or reassign an Analog Input data item:

1. Select **Analog Inputs** from the hierarchy menu.
2. Double-click an Analog Input to edit. The Analog Input Assignment dialog box displays.

**Note:** You can also click the Assignment icon  on the toolbar to display the dialog box.

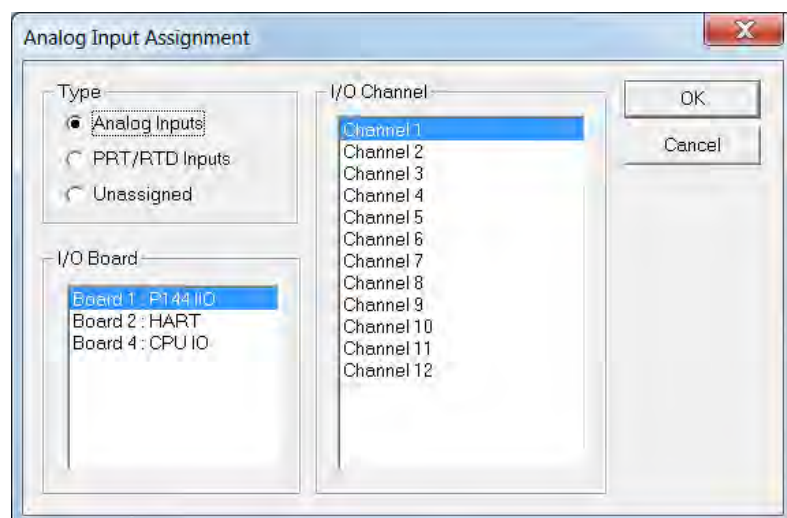

Figure 4-6. Analog Input Assignment dialog box

3. Select an input **Type**. Valid values are **Analog Inputs**, **PRT/RTD Inputs**, or **Unassigned**. The default is **Unassigned**.
4. Select an **I/O Channel** to assign the Analog Input.

---

**Note:** This field lists **only** compatible channels which have either not yet been assigned to a particular unit type or that have already been assigned to inputs of the same unit type. For example, to reassign a pressure input, you can **only** reassign it to an input that is either currently unassigned or already assigned to a pressure input. The HART transmitter and the S600+ must use **matching** measurement units.

---

5. Click **OK** to apply the new assignment. The PCSetup screen displays showing the new assignment.

### 4.3.2 Editing Analog Inputs (AI)

To edit operational settings for an analog input, a PRT/RTD, or a HART input data item:

1. Right-click the desired data item. The system displays a shortcut menu.
2. Select **Settings** on the menu. An input-specific dialog box displays:

---

**Note:** You can also click the Settings icon  on the toolbar after highlighting the data item to display the menu.

---

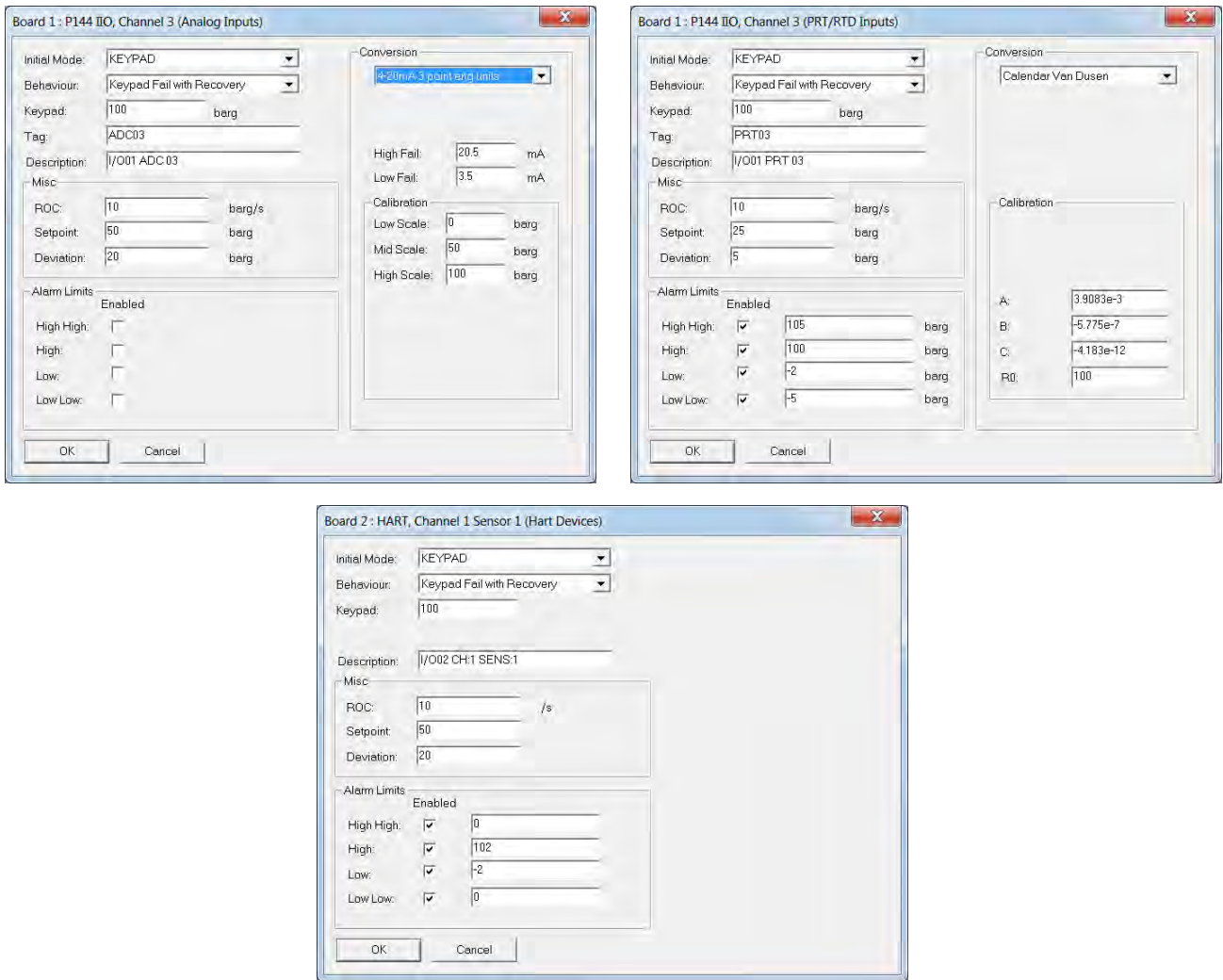

Figure 4-7. Analog Input, PRT/RTD, and HART dialog boxes

3. Select an **Initial Mode** of operation. Valid values are:

Field	Description
<b>Measured</b>	Use the derived calculated value from the incoming signal.
<b>Keypad</b>	Use the keypad value in place of the calculated value. <b>Note:</b> This is the default value.
<b>Last Good</b>	Use the last valid value received from the incoming signal.
<b>Average</b>	Use the rolling average of the last two “good” readings from the incoming signal. <b>Note:</b> Analog inputs are considered valid if the measured current is within Centigrade HI and LO fail limits. PRT/RTD inputs are considered valid while no integrity fail alarms are present. HART inputs are considered valid when no errors are present in the good comms and second status byte indicates the device is healthy.
<b>Weighted</b>	Use the rolling time/flow weight average of the signal. <b>Note:</b> This mode is valid only if you configure this input in a time/flow weighted average calculation table. Refer to <i>Chapter 6, Section 6.2.8, Time &amp; Flow Weighted Averaging</i> .

4. Select a **Behaviour** value. Valid values are:

Field	Description
<b>Disabled</b>	If the input has failed, continue to use this value.
<b>Keypad Fail with Recovery</b>	If the input has failed, change the value to use the Keypad value. When the input has recovered, the system reverts to its previous mode. This mode displays as KEYPAD-F on failure.
<b>Average Fail with Recovery</b>	If the input has failed, change the value to use the average value. When the input has recovered, the system reverts to its previous mode. This mode displays as AVERAGE-F on failure.
<b>Last Good Fail with Recovery</b>	If the input has failed, change the value to use the last valid value. When the input has recovered, the system reverts to its previous mode. This mode displays as LASTGOOD-F on failure.
<b>Keypad Fail no Recovery</b>	If the input has failed, change the value to use the Keypad value. When the input has recovered, the system remains in Keypad mode until manually changed. This mode displays as KEYPAD-F on failure.
<b>Average Fail no Recovery</b>	If the input has failed, change the value to use the Average value. When the input has recovered, the system remains in Average mode until manually changed. This mode displays as AVERAGE-F on failure.
<b>Last Good Fail no Recovery</b>	If the input has failed, change the value to use the Lastgood value. When the input has recovered, the system remains in Lastgood mode until manually changed. This mode displays as LASTGOOD-F on failure.
<b>Weighted Fail no Recovery</b>	If the input has failed, change the value to use the Time / Flow weighted value. When the input has recovered, the system remains in Average mode until manually changed. This mode displays as WEIGHTED-F on failure
<b>Weighted Fail with Recovery</b>	If the input has failed, change the value to use the Time / Flow weighted value. When the input has recovered, the system reverts to its previous mode until manually changed. This mode displays as WEIGHTED-F on failure.

5. Enter a **Keypad** value. The system uses this value either if the Initial Mode is set to **Keypad** or the input has failed and the Behaviour value is set to **Keypad Fail** (with or without recovery).
6. Enter an item **Tag** of up to 12 alphanumeric characters. The system uses this on the front panel of the S600+.
7. Enter an item **Description** of up to 20 alphanumeric characters. The system uses this description on reports, alarm printouts, and displays.
8. Enter a Rate of Change (**ROC**) value. If, in one second, the input variable changes by an amount greater than this value **and** you have enabled alarms (**Advanced Setup > Alarms**), Config600 alarms the operator.
9. Enter values for **Setpoint** and **Deviation**. Config600 uses these values if the operator is required to know when the input variable

has changed. The Setpoint field provides a check value, and the Deviation field indicates the allowed variance.

---

**Note:** Config600 can raise an alarm **only** if you have previously enabled Alarms in Advanced Setup.

---

- 10. Define Alarm Limits.** If you enable an alarm, set a threshold value for that alarm.

On the High and High High alarms, Config600 raises the alarm if the in-use value rises above the entered threshold value. On the Low and Low Low alarms, Config600 raises an alarm if the in-use value falls below the entered threshold value.

- 11. Select a Conversion value:**

- If **analog**, click ▼ to select a valid Conversion value:

<b>Value</b>	<b>Description</b>
<b>0–20mA</b>	Use if you apply a current input directly to the I/O board.
<b>4–20mA</b>	Use if you apply a current input directly to the I/O board.
<b>0–5V</b>	Use if you apply a voltage signal directly to the I/O board or if you place a current loop across a 250-ohm resistor and apply the derived voltage to the I/O board.
<b>1–5V</b>	Use if you apply a voltage signal directly to the I/O board or if you place a current loop across a 250-ohm resistor and apply the derived voltage to the I/O board.
<b>0–20mA 2 point eng units</b>	Use if you apply a current input directly to the I/O board with on-line calibration when the transmitter has a straight-line response but an offset is required. <b>Note:</b> This option enables you to enter Low Scale, High Scale, and Offset values on the S600+ front panel.
<b>4–20mA 2 point eng units</b>	Use if you apply a current input directly to the I/O board with on-line calibration when the transmitter has a straight-line response but an offset is required. <b>Note:</b> This option enables you to enter Low Scale, High Scale, and Offset values on the S600+ front panel.
<b>0–5V 2 point eng units</b>	Use if you apply a voltage signal directly to the I/O board or when you place a current loop across a 250-ohm resistor and apply the derived voltage to the I/O board with on-line calibration when the transmitter has a straight-line response but an offset is required. <b>Note:</b> This option enables you to enter Low Scale, High Scale, and Offset values on the S600+ front panel.
<b>1–5V 2 point eng units</b>	Use if you apply a voltage signal directly to the I/O board or when you place a current loop across a 250-ohm resistor and apply the derived voltage to the I/O board with on-line calibration when the transmitter has a straight-line response but an offset is required. <b>Note:</b> This option enables you to enter Low Scale, High Scale, and Offset values on the S600+ front panel.



Value	Description
0–20mA 3 point eng units	Use if you apply a current input directly to the I/O board with on-line calibration when the transmitter <b>does not</b> have a straight-line response. <b>Note:</b> This option enables you to perform a three-point field calibration on the S600+ front panel or webserver.
4–20mA 3 point eng units	Use if you apply a current input directly to the I/O board with on-line calibration when the transmitter <b>does not</b> have a straight-line response. <b>Note:</b> This option enables you to perform a three-point field calibration on the S600+ front panel or webserver.
0–5V 3 point eng units	Use if you apply a voltage signal directly to the I/O board <b>or</b> if you place a current loop across a 250-ohm resistor and apply the derived voltage to the I/O board with on-line calibration when the transmitter <b>does not</b> have a straight-line response. <b>Note:</b> This option enables you to perform a three-point field calibration on the S600+ front panel or webserver.
1–5V 3 point eng units	Use if you apply a voltage signal directly to the I/O board <b>or</b> if you place a current loop across a 250-ohm resistor and apply the derived voltage to the I/O board with on-line calibration when the transmitter <b>does not</b> have a straight-line response. <b>Note:</b> This option enables you to perform a three-point field calibration on the S600+ front panel or webserver.
0–20mA 2 point mA	Use if you apply a current input directly to the I/O board with on-line calibration when the transmitter has a straight-line response but an offset is required. <b>Note:</b> This option enables you to enter Low mA, High mA, and Offset values on the S600+ front panel.
4–20mA 2 point mA	Use if you apply a current input directly to the I/O board with on-line calibration when the transmitter has a straight-line response but an offset is required. <b>Note:</b> This option enables you to enter Low mA, High mA, and Offset values on the S600+ front panel.
0–5V 2 point mA	Use if you apply a voltage signal directly to the I/O board <b>or</b> when you place a current loop across a 250-ohm resistor and apply the derived voltage to the I/O board with on-line calibration when the transmitter has a straight-line response but an offset is required. <b>Note:</b> This option enables you to enter Low mA, High mA, and Offset values on the S600+ front panel.
1–5V 2 point mA	Use if you apply a voltage signal directly to the I/O board <b>or</b> when you place a current loop across a 250-ohm resistor and apply the derived voltage to the I/O board with on-line calibration when the transmitter has a straight-line response but an offset is required. <b>Note:</b> This option enables you to enter Low mA, High mA, and Offset values on the S600+ front panel.
0–20mA 3 point mA	Use if you apply a current input directly to the I/O board with on-line calibration when the transmitter <b>does not</b> have a straight-line response. <b>Note:</b> This option enables you to perform a three-point field calibration on the S600+ front panel or webserver.

Value	Description
4–20mA 3 point mA	Use if you apply a current input directly to the I/O board with on-line calibration when the transmitter <b>does not</b> have a straight-line response. <b>Note:</b> This option enables you to perform a three-point field calibration on the S600+ front panel or webserver.
0–5V 3 point mA	Use if you apply a voltage signal directly to the I/O board <b>or</b> if you place a current loop across a 250-ohm resistor and apply the derived voltage to the I/O board with on-line calibration when the transmitter <b>does not</b> have a straight-line response. <b>Note:</b> This option enables you to perform a three-point field calibration on the S600+ front panel or webserver.
1–5V 3 point mA	Use if you apply a voltage signal directly to the I/O board <b>or</b> if you place a current loop across a 250-ohm resistor and apply the derived voltage to the I/O board with on-line calibration when the transmitter <b>does not</b> have a straight-line response. <b>Note:</b> This option enables you to perform a three-point field calibration on the S600+ front panel or webserver.

**Note:** Refer to *Appendix D, Field Calibration* for additional information.

- If PRT/RTD, click ▼ to select a valid Conversion value:

Value	Description
DIN	Converts the incoming resistance reading into temperature using the standard DIN 43760 (using the 385 curve).
American	Converts the incoming reading into temperature using the standard IPTS-68 (using the 392 curve).
DIN Offset	Converts the incoming resistance reading into temperature using the standard DIN 43760 (using the 385 curve). Used for on-line calibration where the offset is added to the measured temperature. <b>Note:</b> This option enables you to enter an offset value on the S600+ front panel or webserver.
American Offset	Converts the incoming reading into temperature using the standard IPTS-68 (using the 392 curve). Used for on-line calibration where the offset is added to the measured temperature. <b>Note:</b> This option enables you to enter an offset value on the S600+ front panel or webserver.
Linear Cal	Converts the incoming resistance reading to temperature using the American two-point calibration constants. <b>Note:</b> This option enables you to perform a two-point field calibration on the S600+ front panel or webserver.
Non Linear Cal	Converts the incoming resistance reading to temperature using the American three-point calibration constants. <b>Note:</b> This option enables you to perform a three-point field calibration on the S600+ front panel or webserver.

Value	Description
<b>Calendar Van Dusen</b>	<p>Converts incoming resistance to temperature using the Calendar Van Dusen A, B, C, and R0 constants. Use this option to select other tables (such as IEC) by entering the A, B, C, or R0 constants.</p> <p><b>Note:</b> Select the Calendar Van Dusen option to support other temperature curves (such as DIN 43760 1980 or IEC 60751 2008) when using constants from those standards.</p>

12. Complete any conversion-specific fields for the **analog** conversion value you selected:

**Note:** Conversion settings in this section **may require that you change jumper** (bit link) **settings** on the appropriate I/O board. Refer to the *FloBoss S600+ Flow Computer Instruction Manual* (Form A6115) for further details.

Value	Description
<b>High Scale</b>	<p>Indicates, in mA or V (depending on the selected conversion option), the high-range scaling value (5 V or 20 mA).</p> <p><b>Note:</b> This field <b>does not</b> display for on-line calibration.</p>
<b>Mid Scale</b>	<p>Indicates, in mA or V (depending on the selected conversion option), the middle-range scaling value (5 V or 20 mA).</p> <p><b>Note:</b> This field <b>does not</b> display for on-line calibration.</p>
<b>Low Scale</b>	<p>Indicates, in mA or V (depending on the selected conversion option), the low-range scaling value (0 V, 1 V, 0 mA, or 4 mA).</p> <p><b>Note:</b> This field <b>does not</b> display for on-line calibration.</p>
<b>High Fail</b>	<p>In current modes, indicates the direct reading of the Analog Input at which the transmitter has failed. In voltage modes, indicates (in mA) the current required to pass through a 250-ohm conditioning resistor to achieve the required fail voltage.</p>
<b>Low Fail</b>	<p>Indicates, in mA or V (depending on the selected conversion option), the mid-range scaling value (5 V or 20 mA).</p>

13. Complete any required calibration-specific fields for the conversion factor you selected.

- If **Analog**:

Value	Description
<b>Low Scale</b>	<p>Indicates, in mA or V (depending on the selected conversion option), the low-range scaling value (0 V, 1 V, 0 mA, or 4 mA).</p> <p><b>Note:</b> This field <b>does not</b> display for on-line calibration.</p>
<b>Mid Scale</b>	<p>Indicates, in mA or V (depending on the selected conversion option), the mid-range scaling value (5 V or 20 mA).</p> <p><b>Note:</b> This field <b>does not</b> display for on-line calibration.</p>

<b>Value</b>	<b>Description</b>
<b>High Scale</b>	Indicates, in mA or V (depending on the selected conversion option), the high-range scaling value (5 V or 20 mA). <b>Note:</b> This field <b>does not</b> display for on-line calibration.

▪ **If PRT/RTD:**

<b>Value</b>	<b>Description</b>
<b>Low Scale</b>	Indicates, in degrees Centigrade, the low value for calibration. <b>Note:</b> This field displays <b>only</b> if you select the Linear Cal or Non Linear Cal conversion options.
<b>Mid Scale</b>	Indicates, in degrees Centigrade, the mid value for calibration. <b>Note:</b> This field displays <b>only</b> if you selected the Non Linear Cal conversion option.
<b>High Scale</b>	Indicates, in degrees Centigrade, the high value for calibration. <b>Note:</b> This field displays <b>only</b> if you selected the Linear Cal or Non Linear Cal conversion options.
<b>A</b>	Provides the A constant value for the Calendar Van Dusen conversion. <b>Note:</b> This field displays <b>only</b> if you selected the Calendar Van Dusen conversion option.
<b>B</b>	Provides the B constant value for the Calendar Van Dusen conversion. <b>Note:</b> This field displays <b>only</b> if you selected the Calendar Van Dusen conversion option.
<b>C</b>	Provides the C constant value for the Calendar Van Dusen conversion. <b>Note:</b> This field displays <b>only</b> if you selected the Calendar Van Dusen conversion option.
<b>R0</b>	Provides the R0 constant value for the Calendar Van Dusen conversion. <b>Note:</b> This field displays <b>only</b> if you selected the Calendar Van Dusen conversion option.

**14.** Complete any Alarm Limit values:

<b>Value</b>	<b>Description</b>
<b>High High</b>	Select the checkbox and enter a value to which the input value must rise to generate a High High alarm.
<b>High</b>	Select the checkbox and enter a value to which the input value must rise to generate a High alarm.
<b>Low</b>	Select the checkbox and enter a value to which the input value must lower to generate a Low alarm.
<b>Low Low</b>	Select the checkbox and enter a value to which the input value must lower to generate a Low Low alarm.

**15.** Click **OK** to apply the edits. The PCSetup screen displays.

### 4.3.3 Adding a New I/O Point

To add either a new analog input or a new PRT/RTD I/O point:

1. Right-click in the right-hand pane of the PCSetup screen. The system displays a shortcut menu.
2. Select **New I/O Point** on the shortcut menu. The system displays the Analog Input Assignment dialog box.

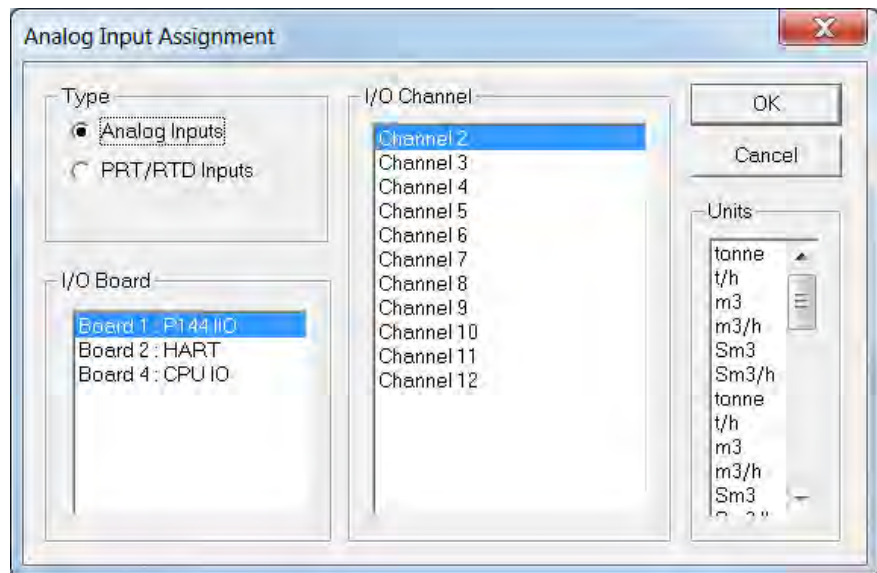

Figure 4-8. Analog Input Assignment dialog box

3. Complete the **Type**, **I/O Board**, **I/O Channel**, and **Units** fields as described in *Editing Analog Inputs*.

---

**Note:** Config600 highlights the default values for each field. You can accept or change those defaults as necessary.

---

4. Select the type of Units.
5. Click **OK** to apply the new I/O point to your configuration. The system redisplay the PCSetup screen with your new I/O point.

## 4.4 Analog Outputs (AO)

You can assign each analog output channel to an individual data item. You can also assign individual data items to more than one output, which allows you to create a repeat signal.

Each installed I/O module (P144) provides up to four analog output channels. Neither the Prover module (P154) nor the HART module (P188) provide any analog output channels.

### 4.4.1 Editing Analog Outputs

To edit an analog output data item:

1. Select **Analog Outputs** from the hierarchy menu. The system displays all currently defined analog outputs in the right-hand pane.

2. Double-click an analog output to edit. The Analog Output Assignment dialog box displays.
3. Select the **Item Type** to assign the Analog Output (or select Unassigned to deselect the output). Config600 completes the Item field with available data items:

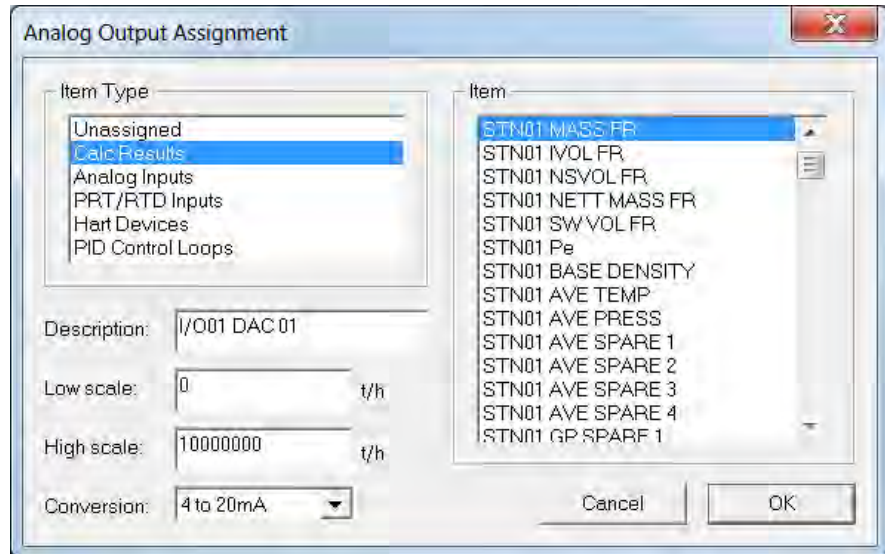

Figure 4-9. Analog Output Items

4. Select an item in the Item field to assign to the item type.
5. Define the output scales by entering values in the **Low scale** and **High scale** fields. S600+ uses these values when converting the raw value into a scaled analog output value. The default value for the Low scale is **0**; the default value for the High scale is **10000000**. To invert the output, set the High scale lower than the Low scale.

---

**Note:** Config600 changes the units associated with these fields (kg/m<sup>3</sup>, t/h, m<sup>3</sup>/h, pls/m<sup>3</sup>, and such) based on the data item you select.

---

6. Select a **Conversion** factor for the Low scale and High scale values. Valid options are **0 to 20mA** or **4 to 20mA**. The default is **4 to 20mA**. For example, if you select the 4 to 20mA option, Config600 equates the Low scale value to 4 mA and the High scale value to 20mA.
7. Click **OK** to apply your selections. The system redisplay the PCSetup screen with your new assignments.

---

**Note:** Refer to *Appendix D, Field Calibration*, for additional information.

---

## 4.5 Density Inputs

Config600 supports either single or twin densitometers, which you assign to each station or stream as you develop a configuration. You can assign each densitometer frequency to a specific density input channel on the I/O module.

Each installed I/O module (P144) provides three available density input channels. Each installed Prover module (P154) provides two channels.

### Notes:

- If the densitometer also acts as the temperature element for the meter, assign the meter temperature, densitometer temperature, and pressure transmitter to the same analog input.
- Using the Streams option in the PCSetup Editor, you can switch a frequency input to an analog signal. See *Chapter 6, Stream Configuration*.

### 4.5.1 Assigning Density Input

To assign or reassign a density input data item:

1. Select **Density Inputs** from the hierarchy menu. The system displays all currently defined density inputs in the right-hand pane.
2. Double-click a **Density Input** to edit. The Assign Input dialog box displays.

**Note:** You can also click the Assignment icon  on the toolbar to display the dialog box.

3. Select the **I/O Board** to assign the density input (or select Unassigned to deselect the input). Config600 lists available channels in the I/O Channel field:

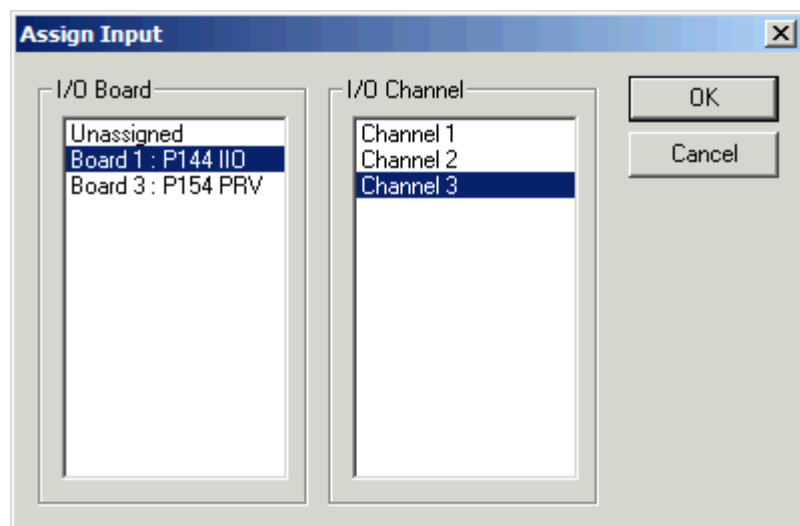

Figure 4-10. I/O Channels for Density Input

4. Select the **I/O Channel** for the density input.
5. Click **OK** to apply the assignment. The system redisplay the PCSetup screen with your new I/O assignment.

**Notes:**

- Before displaying the PCSetup screen, Config600 may display a reminder for you to enable the alarms for the new assignment.
- When you assign a densitometer input, the station or stream density configuration page displays.

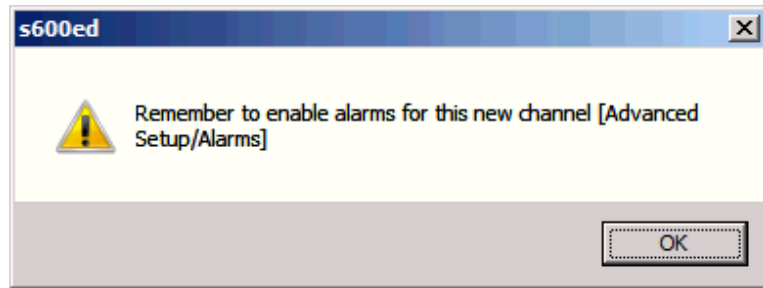

Figure 4-11. Alarm Reminder

### 4.5.2 Editing Density Inputs

To edit the description for a density data item:

1. Select **Density Inputs** from the hierarchy menu. The system displays all currently defined density inputs in the right-hand pane.
2. Right-click a data item to edit. The system displays a shortcut menu.
3. Select **Settings** on the shortcut menu. The system displays the Edit Description dialog box:

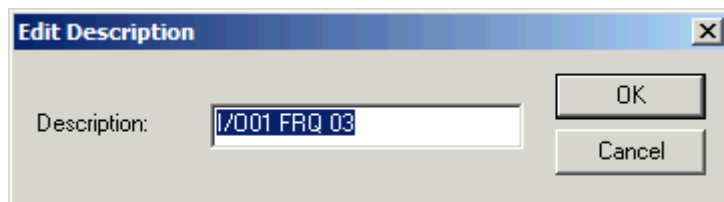

Figure 4-12. Edit Description dialog box

4. Edit the current item description, using no more than 20 alphanumeric characters.
5. Click **OK** to apply the new item description. The system redisplay the PCSetup screen with your new item description.



## 4.6 Turbine Inputs

A turbine or positive displacement meter provides inputs to the system in the form of single-pulse or dual-pulse data. You assign the turbine pulse inputs to an I/O channel on the I/O board.

Each installed I/O module (P144) or Prover module (P154) provides up to four pulse input channels. You can define these channels as:

- Four single-pulse inputs.
- Two dual-pulse inputs.
- Two single-pulse and one dual-pulse inputs.



**Caution**

The S600+ cannot count pulses unless the I/O module (P144) or Prover module (P154) is fitted with a dual-pulse P148 mezzanine board.

### 4.6.1 Assigning Turbine Inputs

To assign or reassign turbine input data items:

1. Select **Turbine Inputs** from the hierarchy menu. The system displays all currently defined turbine inputs in the right-hand pane.
2. Double-click a turbine input to edit. The Pulse Input Assignment dialog box displays.

**Note:** You can also click the Assignment icon  on the toolbar to display the dialog box.

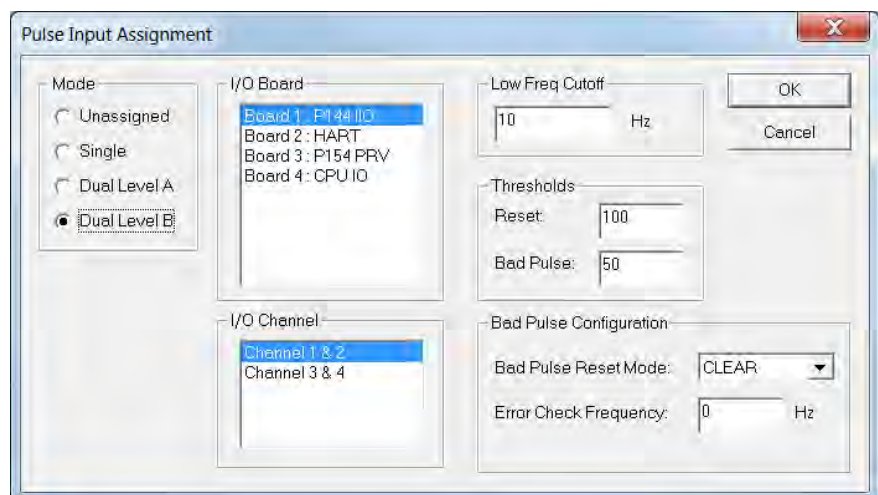

Figure 4-13. Pulse Input Assignment dialog box

3. Select a pulse mode:

Field	Description
<b>Unassigned</b>	Select to un-assign a pulse input.
<b>Single</b>	Select if only one pulse train is available from the meter.
<b>Dual Level A</b>	Select if the meter provides dual pulses at the same frequency but out of phase. <b>Note:</b> This option conforms to Level A interpolation in accordance with ISO 6551 (IP252/76).

Field	Description
Dual Level B	Select if the meter provides dual pulses at the same frequency but out of phase. <b>Note:</b> This option conforms to Level B interpolation in accordance with ISO 6551 (IP252/76).

4. Select the **I/O board** for the pulse turbine input.
5. Select an **I/O channel** to use.
  - For dual-pulse input on the I/O (P144) module, select channels 1 & 2 **or** 3 & 4.
  - For dual-pulse input on the Prover (P154) module, select channels 2 & 3 **or** 4 & 5 (Config600 reserves channel 1 for the raw input value from an internal or external raw pulse output).
  - Four channels (1, 2, 3, and 4 for I/O modules **or** 2, 3, 4, and 5 for Prover modules) are available for single-pulse inputs.
6. Complete the **Low Frequency Cutoff** field using a Hertz value. If the S600+ receives pulse frequencies below this value, it sets the flow rate and input frequency to zero.

---

**Note:** Totalisation still occurs in Liquid Turbine applications, but does not occur in Gas Turbine applications when the frequency is below the Low Frequency Cutoff value.

---

7. Complete the fields in the **Thresholds** pane (which displays **only** if you selected Dual Level A or B as a pulse mode).

Field	Description
Reset	Determines the number of consecutive valid pulses the system must receive after the occurrence of the bad pulse alarm before it clears the bad pulse alarm. The default value is <b>200000</b> . <b>Note:</b> Config600 ignores all bad pulses that occur below the value you enter in the Error Check Frequency field.
Bad Pulse	Indicates the number of bad pulses that need to accumulate in the bad pulse buffer before the system raises the bad pulse alarm. The <b>default</b> is <b>50</b> .

8. Complete the fields in the **Bad Pulse Configuration** pane (which displays **only** if you selected Dual Level A or B as a pulse mode).

Field	Description
Bad Pulse Reset Mode	Defines how the system manages the bad pulse buffer. Valid values are <b>Clear</b> (clear the buffer when the input frequency is below the error check frequency) or <b>Set</b> (do not clear the buffer). The <b>default</b> value is <b>Clear</b> .
Error Check Frequency	Sets a threshold input frequency value. While Config600 detects and records pulses below this value, it does not include them in bad pulse checking.

9. Click **OK** to apply the assignments. The PCSetup screen displays showing your new values.

## 4.6.2 Editing Turbine Inputs

To edit the description for a pulse input data item:

1. Select **Turbine Inputs** from the hierarchy menu. The system displays all defined turbine Inputs.
2. Right-click a data item to edit. The system displays a shortcut menu.
3. Select **Settings** on the shortcut menu. The system displays the Edit Description dialog box:

**Note:** You can also click the Settings icon  on the toolbar after highlighting the data item to display the menu.

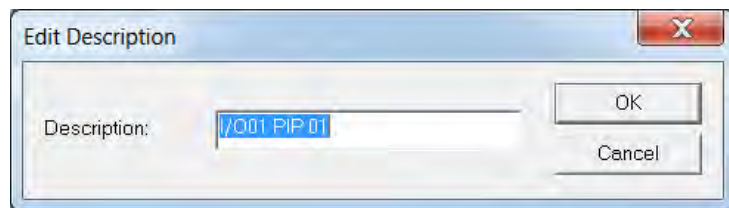

Figure 4-14. Edit Description dialog box

4. Edit the current item **Description**, using no more than 25 alphanumeric characters.
5. Click **OK** to apply the new item Description. The system redisplay the PCSetup screen with your new item Description.

## 4.7 Pulse Outputs

Use pulse outputs to derive cumulative totals for display on a counter, a totaliser, or DCS system. You can assign each pulse output to a specific pulse output channel on the I/O board.

Each installed I/O (P144) module provides five pulse output channels, and each installed Prover (P154) module provides four channels.

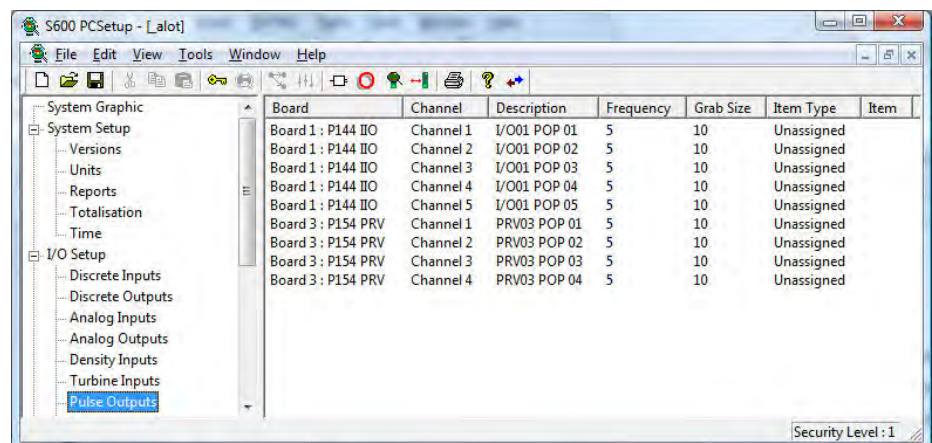

Figure 4-15. Pulse Output Items

### 4.7.1 Assigning Pulse Outputs

To assign or reassign Pulse Output data items:

1. Select **Pulse Outputs** from the hierarchy menu. The system displays all defined pulse output data items.
2. Double-click a pulse output to edit. The Pulse Output Assignment dialog box displays.

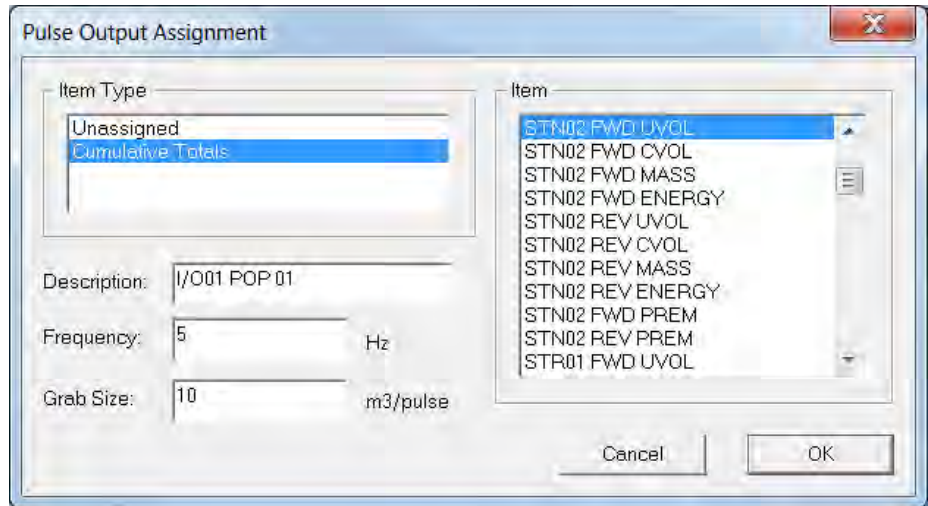

Figure 4-16. Pulse Output Items

3. Select **Cumulative Totals** in the Item Type pane. Config600 completes the Item field with available items.
4. Select an **Item** in the Item pane to associate with the Pulse Output.
5. Edit the **Description** associated with the item and item type. Config600 uses this value only on screen displays and reports.
6. Complete the **Frequency** field using a Hertz value to indicate the output's pulse width. For example, a frequency of 5 Hz equates to a 200 millisecond pulse width with a 50/50 duty cycle. The default value is **5**.
7. Complete the **Grab Size** field to indicate the number of units per pulse (the type of unit being dependent on the application) Config600 accumulates before sending a pulse. For example, use a Grab Size value of 10m<sup>3</sup> to measure increments in the Cumulative Volume Totals for each outputted pulse. The default is **10**.
8. Click **OK** to apply the new assignment. The PCSetup screen displays showing the new assignment.

## 4.8 HART Modules

Each Highway Addressable Remote Transducer (HART) module supports 12 channels with up to 8 transmitters per channel. However, the S600+ has an overall restriction of 50 transmitters.

**Note:** You cannot add a HART module definition to an existing configuration file. If you add a HART module to your S600+, you must create an entirely **new** configuration file. Be sure to assign the I/O module (P144) to address 1 and the HART module (P188) to address 2.

The S600+ supports 12 channels, with up to 8 sensors multidropped from each channel. Since each sensor takes approximately 0.5 second of scan time, the more sensors you add to each channel, the slower the I/O update time becomes for that channel. Also, the HART module reads only the HART digital signal, not the channel's analogue value. If you require both, you must physically wire the HART signal to an ADC and HART channel.

By default, the S600+ acts as the primary HART master. Ensure there is no other primary master connected to the channel. For dual master support or instructions on how to set the S600+ to secondary master, contact Technical Support.

### 4.8.1 Editing HART Settings

To edit or reassign settings for the HART data items:

1. Select **HART Boards** from the hierarchy menu. The system displays the HART Board configuration screen:

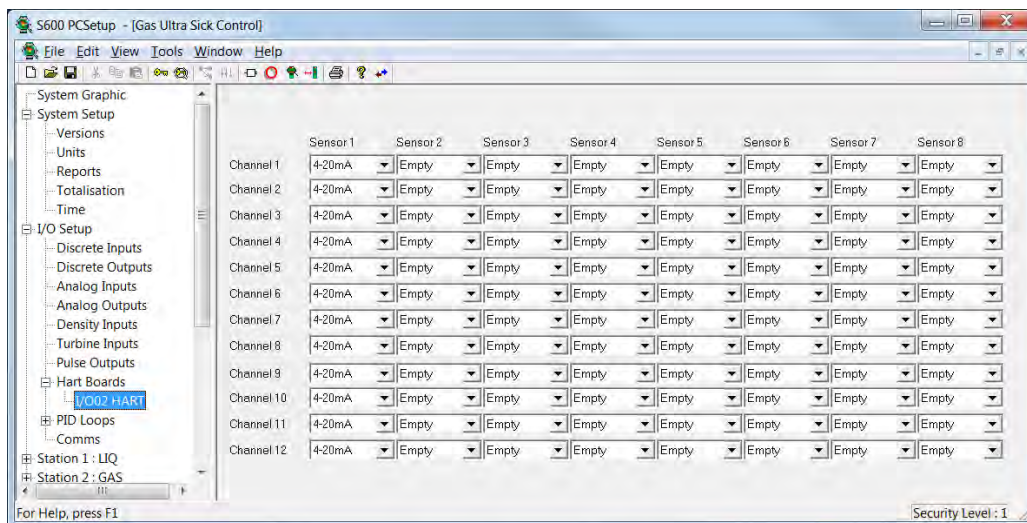

Figure 4-17. HART Module Configuration screen

2. Complete the screen based on the number of sensors associated with each channel on the S600+. Click ▼ to display valid values.

## 4.9 PID Loop Settings

The PID control task provides primary control with secondary override control (that is, **two** control loops, each with its own parameters). You can either select the output according to criteria you can enter or allow a status input to the task to select the output.

You can configure an individual PID task for each station and stream, subject to the I/O providing sufficient analog outputs.

Typically, a liquid application has flowrate primary control which changes to pressure control if the pressure falls too low. A gas application has a primary pressure control which is overridden by flow control if the flowrate becomes too high.

### 4.9.1 Assigning PID Loops

To assign or reassign PID data items:

1. Select **PID Loops** from the hierarchy menu. The system hides the setup fields until you assign an analog output to the PID loop (see *Figure 4-18*).

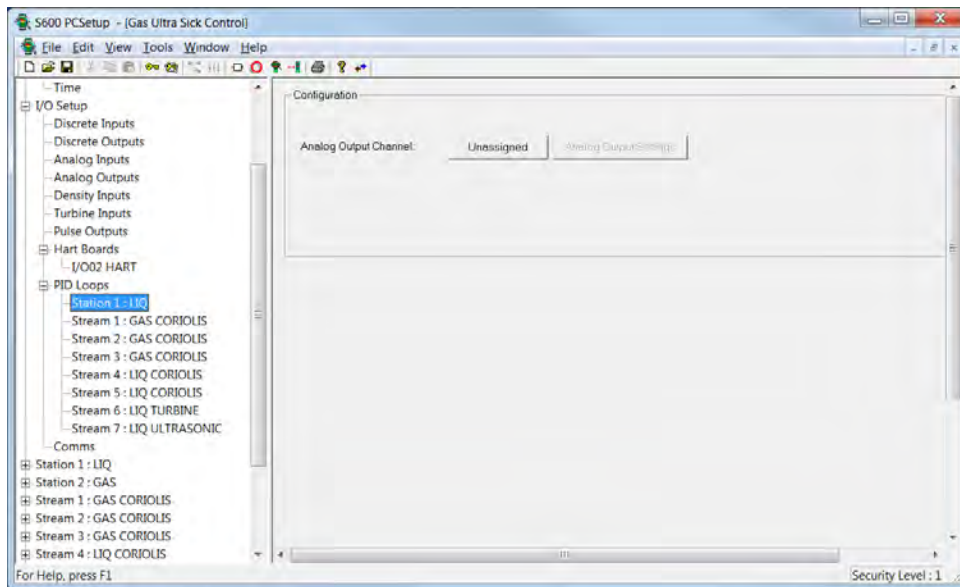

Figure 4-18. PID Loop Enabled screen

2. Select **Unassigned** (or select the Analog Outputs from the hierarchy menu) to identify the Analog Output values you desire to associate with each PID control loop.

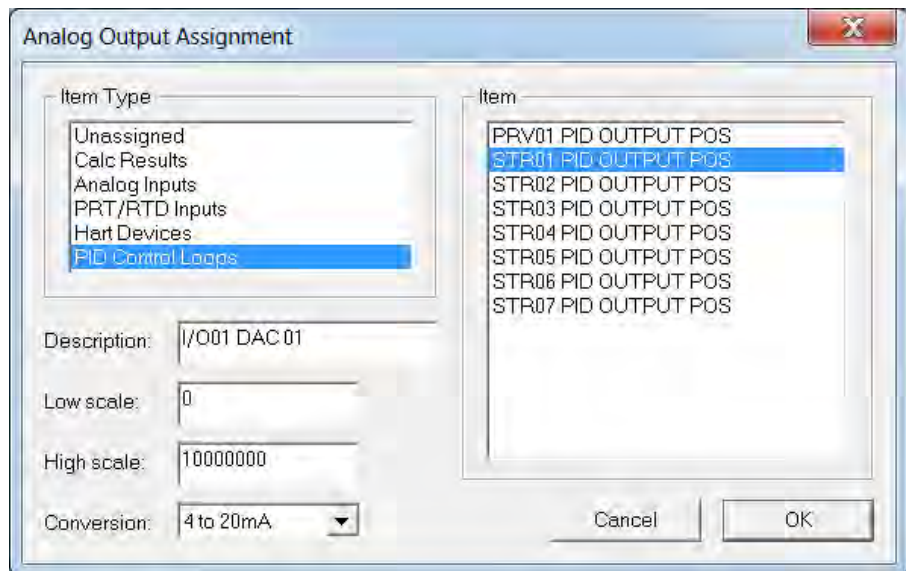

Figure 4-19. Analog Output Assignment screen

3. Select **PID Loops** from the hierarchy menu. The system expands the hierarchy to display the control loops defined for each I/O module.
4. Select a **control loop**. Config600 displays the common data items for this loop.

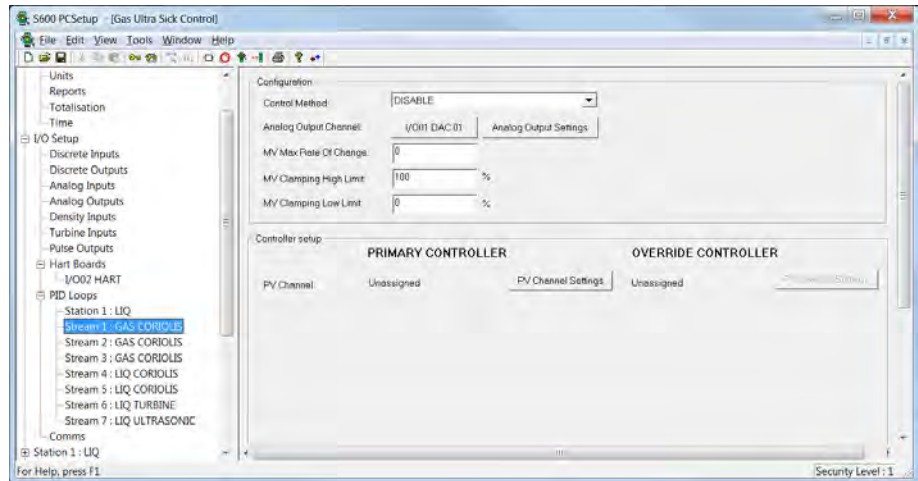

Figure 4-20. PID Loop Output Assigned screen

5. Assign the Primary Controlled Process Variable to enable the primary controller.
6. Click **PV Channel Settings**. A Select Object dialog box displays. Use it to assign the Analog Output value associated with this PID control loop.

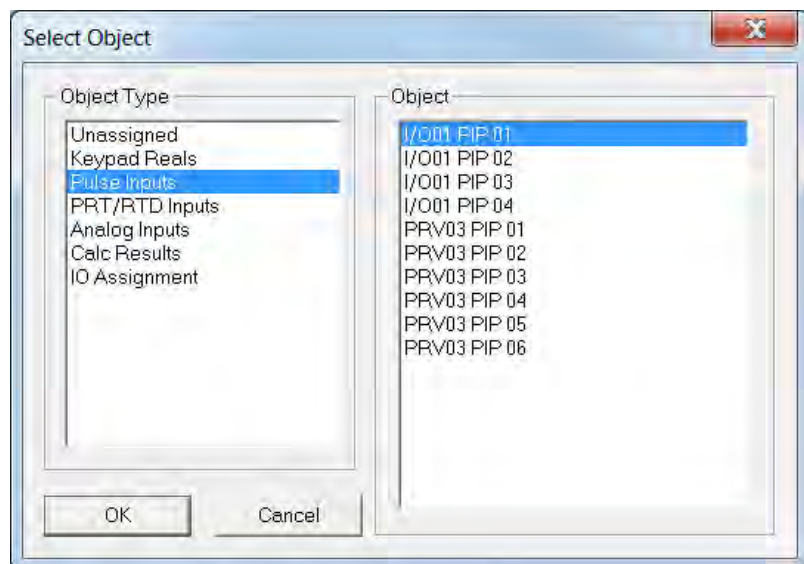

Figure 4-21. PID Loop Output Assigned screen

7. Assign – if required – the Override Controller process variable. Config600 expands the screen content.

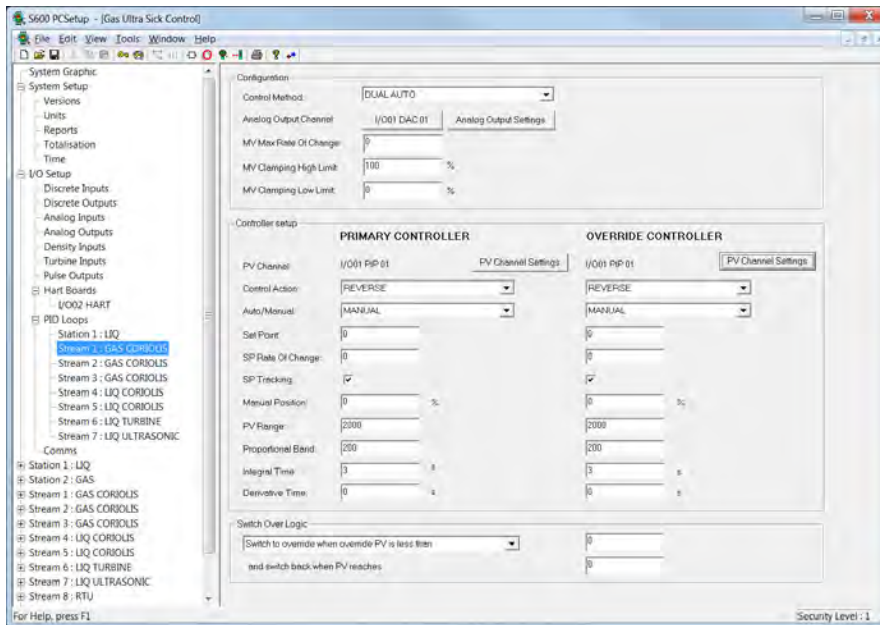

Figure 4-22. PID Loop PV Assigned screen

8. Select the Control Method for the PID loop. Click ▼ to display all valid process variable values.

Field	Description
<b>Disable</b>	The PID algorithm does not execute and the output does not update
<b>Dual Auto</b>	Selects Primary control with Secondary override according to the settings defined in Switch Over Logic field.
<b>Primary Only</b>	Uses the primary control settings with no switching to secondary control.
<b>Secondary Only</b>	Uses the second control settings; does not switch to primary control.
<b>User Logic</b>	Uses a KPINT status input to select either primary or secondary control. The status can be set by an operator, a digital input, user logic in a LogiCalc, or downloaded from a supervisory computer.

9. Complete the **Auto/Manual** field. Valid values are **Manual** (the system forces the output to the Manual Position value) or **Auto** (the system uses the calculated value from the PID algorithm to drive the analog output). The default value is **Manual**.
10. Indicate an **MV Max Rate Of Change** as a percentage of the output per second. This value controls the Manipulated Variable output's maximum rate of change (ROC). The default is **60** (60% of output). For example, entering **20** in this field limits a full range (0 to 100) change to a minimum of 5 seconds.

**Note:** Enter **0** in the MV Max Rate of Change field to override the field.

11. Indicate an **MV Clamping High Limit** as a percentage of the output. This value limits the Manipulated Variable output's maximum value. The default is **100**.



12. Indicate an **MV Clamping Low Limit** as a percentage of the output. This value limits the Manipulated Variable output's minimum value. The default is **0**.
13. **PV Channel** shows the measured input selected for the PID loop.

---

**Note:** The system grays out the Override Controller PV Channel Settings button until you assign the Primary Controller PV Channel.

---

14. Complete the **Control Action** field on the PID Loop screen. The system uses this value to determine whether to increase or decrease the output when the process variable exceeds the SP (Setpoint) value. Valid values are **Reverse** (reduce the output when the process variable is greater than the Setpoint value) or **Forward** (increase the output when the process variable is greater than the Setpoint value). The default is **Reverse**.
15. Define a **Set Point** value, which the system—when in Auto mode—attempts to achieve by controlling the output. This is an initial value that you can change through the S600+ front panel. It must be in the same units as the Process Variable.
16. Complete the **SP Rate Of Change** field. The default is **0**.

Config600 uses this value to control the rate of change (ROC) of the setpoint. The value defines the maximum rate of change, causing the setpoint to change as a percentage of the setpoint range incrementally to the new entered Set Point value. Use this value as a component of flow profiling, for example, at the start of a batch.

---

**Note:** Enter **0** to override the SP Rate of Change field.

---



**Warning** If you override this parameter, then the rate of change at the output occurs as fast as the unit can react to a new setpoint value being entered. This results in a step change of the output value rather than a smooth transition from one point to another.

---

17. Select the **SP Tracking** checkbox to enable setpoint tracking. This field works in conjunction with the value you enter in the Auto/Manual field:
  - With SP Tracking **enabled and** in Auto mode, the system sets the value in the Manual Position field equal to the current output value.
  - With SP Tracking **enabled and** in Manual mode, the system sets the value in the SP (Setpoint) field equal to the process variable.
  - With SP Tracking **disabled and** in Auto mode, the value in the Manual Position field remains unchanged.
  - With SP Tracking **disabled and** in Manual mode, the SP value remains unchanged and the system sets the integral action field to the value required to maintain the current position.

18. Complete the **Manual Position** field. This value represents the output value when the Auto/Manual mode is set to Manual.
19. Complete the **PV Range** field to identify the range for the process variable measuring instrument. The value must be in the same units as the Process Variable.
20. Complete the **Prop Band** (Proportional Bandwidth) field. This value is a tuning parameter expressed as a percentage of the PV Range. It makes a change to the output proportional to the current error.
21. Complete the **Integral Time** field. This value, expressed in seconds, is a tuning parameter. It makes a change to the output based on the sum of previous errors.

---

**Note:** If the Integral Time is **0**, the system sets the integral action to zero.

---

22. Complete the **Derivative Time** field. This value, expressed in seconds, is a tuning parameter. It makes a change to the output based on the rate of change of the error.

---

**Note:** If the Derivative Action Time is **0**, the system sets the derivative action to zero.

---

23. The Dual Auto Control Method uses **Switch Over Logic** criteria to decide whether to use the output produced by the **primary** control loop or the output produced by the **secondary** override control loop. The test compares the override process variable with an entered limit, and can test for either lower (such as too low pressure) or higher (such as too high flowrate).

- **Switch to override when override PV is less than** the entered value (to the right of this selection on the screen), and **switch back when PV reaches** the entered value (to the right of this selection on the screen).
- **Switch to override when override PV is greater than** the entered value (to the right of this selection on the screen), and **switch back when PV reaches** the entered value (to the right of this selection on the screen).

---

**Note:** The Switch Over Logic option displays **only** if you select **Dual Action** in the Control Method field.

---

24. Click the hierarchy menu when finished. Config600 displays an Apply Changes dialog box.
25. Click **Yes** to apply the changes to the configuration file. The PCSetup screen redisplay.

## 4.9.2 Proportional Plus Integral and Derivative Action

The method for PID control is to calculate an error that is the difference between the current measured value of the process variable (usually flowrate or pressure) and a setpoint value required for the

variable, and to convert the error to a correction which can be applied to the output to reduce the error to zero.

Forward/Reverse action describes the direction in which correction is applied to decrease the error. For flowrate control using a flow control valve, when the process variable is greater than the setpoint, the output needs to be reduced to close the valve slightly, and this is defined as Reverse action. For pressure control in the same situation, the output would need to be increased and this is defined as Forward acting.

The three components each provide a different type of correction to the output and adjustment of the terms effectively changes the amount of damping applied; the proportional component applies to the current error, the integral component applies to the sum of previous errors over a period and the derivative component applies to the rate of change of the error.

**PID Controller** The PID controller output is calculated from the sum of the proportional, integral, and derivative actions:

$$\text{Output} = P + I + D$$

Each term depends on the Error and Gain:

- If the control action is **Forward**:

$$\text{Error} = \text{Process Variable} - \text{Setpoint}$$

- If the control action is **Reverse**:

$$\text{Error} = \text{Setpoint} - \text{Process Variable}$$

- If the proportional gain is applied to all three terms:

$$\text{Gain} = 1 / \text{PV Range} \times 100 / \text{Proportional Band} \times 100$$

- If the algorithm is processes at regular intervals:

$$\text{Delta Time} = \text{Current Time} - \text{Previous Time}$$

**Proportional Action (P)** The degree of proportional action (P) is directly proportional to the error and is calculated from the formula:

$$P = \text{Error} \times \text{Gain}$$

A high proportional action produces a large change in the output for a given change in the error, a low proportional action produces a small change in the output, that is the action is less sensitive. If the proportional gain is too high the system becomes unstable.

A suitable initial value for flowrate control is 200%.

### **Integral Action (I)**

The degree of integral action (I) is calculated from the formula:

$$I (\text{new}) = I (\text{previous}) + (\text{Error} \times \text{Gain} \times \text{Delta Time}) / \text{Integral Action Time}$$

Integral action provides a cumulative offset that eliminates the residual error.

A suitable initial value for flowrate control is 3.0 seconds.

**Derivative**

**Action (D)** The degree of derivative action (D) is calculated from the formula:

$$D = (\text{Error} - (2 \times \text{Old Error}) + \text{Very Old Error}) \times \text{Gain} \times \text{Derivative Action Time} / \text{Delta Time}$$

Derivative action responds to rate of change in successive errors. The action is sensitive and anything greater than a small value of the derivative action time can make the system unstable.

A suitable initial value for flowrate control is 0.01 seconds.

## 4.10 Communications Port

---

During the creation of a configuration, you specify the communications ports. Once the configuration has been created, you must configure the “tasks” for the communications port(s).

A communication “task” defines the communications links to any devices connected to the S600+. The task defines the communications or network port and communication parameters for the port. You can define up to 20 communications tasks for the S600+ and assign each task a specific function (such as Modbus Master, Modbus Slave, or Printer). Each task must be allocated to a dedicated communications port. If you configure a serial port, the task allows you to configure the settings for the COM ports to the external devices.

The S600+ supports Modbus, Modbus Enron (Modbus with EFM Extensions), Modbus encapsulated in TCP/IP, Modbus/TCP, and Printing over Ethernet.

---

**Notes:**

- EFM is Electronic Flow Metering or Measurement.
  - For Modbus encapsulated in TCP/IP and Modbus/TCP, the maximum number of RTU’s that can be connected to a single Port (501, 502, etc.) is 2.
- 

S600+ supports:

- Slave and master peer-to-peer
- Q.Sonic
- Slave and master functionality in Modbus
- Slave and master functionality in Modbus Enron (EFM)
- Slave and master functionality in Modbus encapsulated in TCP/IP
- Slave functionality in Modbus/TCP
- Master TCP/IP communication
- Printer
- Network Time Protocol (NTP)

### 4.10.1 Editing a Communications Task

To edit a communication task:

1. Select **Comms** from the hierarchy menu. The system displays the Communication Task configuration screen:

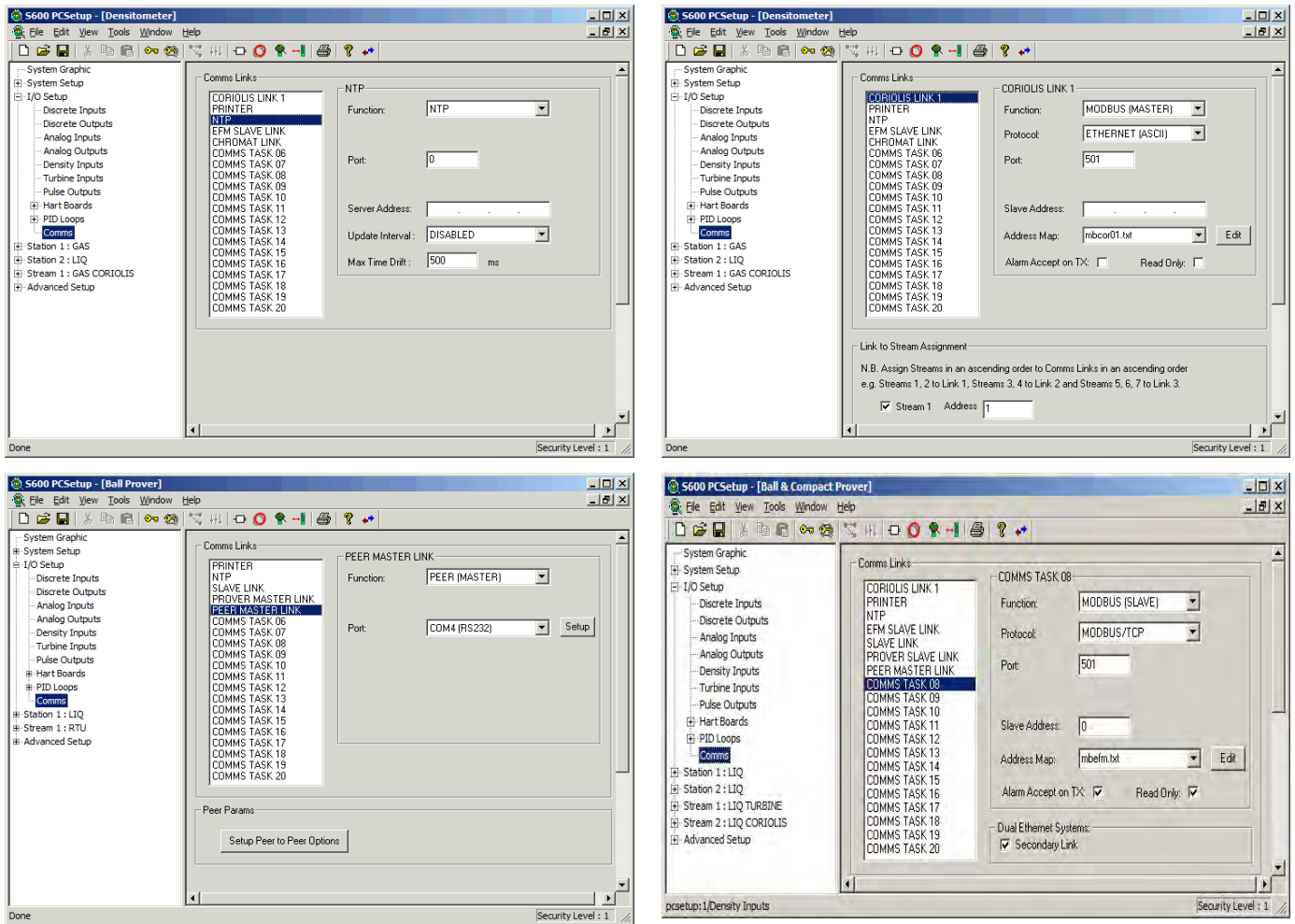

Figure 4-23. Example Communication Task Configurations

2. Select a value in the **Comms Links** field. Config600 displays the values associated with that Comm Link type in the right-hand side of the screen. The title of that values pane also changes to reflect the selected Comm Link type.
3. Complete the values for the selected Comms Link:

**Note:** Not all fields display for each Comm Link option.

Field	Description
Function	Indicates all valid communication port functions. Click ▼ to display all valid functions.

Field	Description
<b>Protocol</b>	<p>Select a protocol, if appropriate. Click ▼ to display all valid protocols, which include Serial (ASCII), Serial (RTU), Ethernet (ASCII), Ethernet (RTU), Modbus/TCP, Printer Serial, and Printer Ethernet.</p> <p><b>Note:</b></p> <ul style="list-style-type: none"> <li>▪ RTU (Remote Transmission Unit) is the preferred protocol for increased performance.</li> <li>▪ <b>Before</b> you change the Protocol field from <b>Serial</b> [Serial (ASCII), Serial (RTU), or Printer Serial] to <b>Ethernet</b> [Ethernet (ASCII), Ethernet (RTU), Modbus/TCP, or Printer Ethernet], set the Port field to <b>NONE</b> to ensure the serial port is available for future use.</li> </ul>
<b>Port</b>	<p>Sets the primary port for the communication task. If available, click ▼ to display all valid ports. Click <b>Setup</b> (if present) to display a Port Setup dialog that you use to define communication options (baud rate, data bits, stop bits, and parity values) for the port you select. The port depends on the type of Comms link you select.</p> <p><b>Notes:</b></p> <ul style="list-style-type: none"> <li>▪ When set to <b>0</b>, the NTP uses any available port when communicating with a public NTP server.</li> <li>▪ For Modbus encapsulated in TCP/IP and Modbus/TCP, the maximum number of RTU's that can be connected to a single Port (501, 502, etc.) is 2.</li> </ul>
<b>Setup</b>	<p>Click to display a Port Setup dialog box that you use to define communication options for the selected port type.</p> <p><b>Note:</b> The Comm Link type dictates which fields selectively appear on this dialog box.</p>
<b>Baud Rate</b>	<p>Indicates the serial transfer rate. Click ▼ to display all valid values. The default value is <b>38400</b>.</p>
<b>Data Bits</b>	<p>Indicates the number of data bits the port uses. Click ▼ to display all valid values. The default value is <b>8</b>.</p>
<b>Stop Bits</b>	<p>Indicates the number of stop bits the port uses. Click ▼ to display all valid values. The default value is <b>1</b>.</p>
<b>Parity</b>	<p>Indicates the type of parity used to detect data corruption during transmission. Click ▼ to display all valid values. The default value is <b>None</b>.</p>
<b>Hardware Handshake</b>	<p>Sets RTS/CTS Handshaking. When you select this checkbox, the ready to send (RTS) line fluctuates between on and off.</p>

Field	Description
	<p><b>RTS On Delay</b> Sets, in milliseconds, the amount of time Config600 waits after turning on the ready to send (RTS) signal before beginning transmission. The default is <b>0</b>. You can change this value to optimise communications. The default value should be sufficient for dial-up modems and EIA-232 (RS-232) connections. For older radios, you may need to set this value to 0.2 seconds. For newer radios, 0.02 seconds should be sufficient.</p>
	<p><b>RTS Off Delay</b> Sets, in milliseconds, the amount of time Config600 waits after transmitting a message before turning off the ready to send (RTS) signal. The default is <b>0</b>. You can change this value to optimise communications. The default value should be sufficient for dial-up modems and EIA-232 (RS-232) connections. For radios, a value of 0.01 may be appropriate.</p> <p><b>Note:</b> These variables may change per your situation. These are general values that you need to assess for each circumstance.</p>
<b>Address Map</b>	<p>Identifies the Modbus file Config600 uses to map data.</p> <p>Click <b>Edit</b> (if present) to open the Modbus Editor and edit the file (see <i>Chapter 14, Modbus Editor</i> for more information).</p>
<b>IP Address</b>	<p>If you select the <b>Modbus (Master)</b> function <b>and</b> the Ethernet or Modbus protocols, enter a Slave IP Address in addition to identifying the port.</p>
<b>Server Address</b>	<p>Indicates the TC/IP address of the NTP server used for time synchronisation.</p> <p><b>Note:</b> This option displays <b>only</b> when you select NTP.</p>
<b>Slave Address</b>	<p>If you select the <b>Modbus (Slave)</b> function, you must also complete the <b>Slave Address</b> field. This is a switch, not an IP address. Enter either a valid Modbus address between <b>1</b> and <b>247</b> or enter <b>0</b>. If you enter <b>0</b>, then the Modbus task uses the value entered on the S600+ (refer to <i>Chapter 7, Startup</i>, in the <i>FloBoss S600+ Flow Manager Instruction Manual</i>, Form A6115). This is useful when multiple streams with identical configurations require unique slave addresses.</p>

Field	Description
<b>Update Interval</b>	Indicates how frequently the S600+ connects with the NTP server and checks for time drift. Valid values are <b>Disabled</b> (the default), <b>Daily</b> , or <b>Weekly</b> . Click ▼ to display all values. This update occurs between 10 and 50 seconds past the minute. <b>Note:</b> This option displays <b>only</b> if you select NTP.
<b>Max Time Drift</b>	Defines (in milliseconds) the threshold at which the the S600+ resets its internal clock. This threshold is the maximum point of difference between the NTP server and the S600+. For example, if the difference between the NTP server and the S600+ check exceeds this value, the S600+ clock adjusts. Any resynchronisations appear in the event log. The time difference is in module (+/- Max time drift). <b>Note:</b> This option displays <b>only</b> when you select NTP.
<b>Alarm Accept on TX</b>	Allows the S600+ to automatically acknowledge and accept alarms locally when they are transmitted on the Modbus link. With this option enabled, the S600+ accepts <b>all</b> alarms when polled for <b>any</b> data.
<b>Read Only</b>	Prevents the Modbus link from writing data to the S600+.
<b>Secondary Link</b>	If you select the <b>Modbus (Slave)</b> function <b>and</b> the Ethernet (RTU) or Modbus/TCP protocol, select Secondary Link in Dual Ethernet Systems to indicate that the slave unit is on the secondary Ethernet port. <b>Note:</b> Modbus (Master) is not supported on the second network card.
<b>Setup Peer to Peer Options</b>	Click to display the Peer Params Setup dialog, which you use to select options for peer-to-peer networking. <b>Note:</b> This option displays <b>only</b> when you select the Peer Master Link or Peer Slave Link.
<b>Link to Stream Assignment</b>	Assign streams in an ascending order to Comm Links in an ascending order. For example, Streams 1 and 2 to Link 1; Streams 3 and 4 to Link 2; and Streams 5, 6, and 7 to Link 3. <b>Note:</b> This option displays <b>only</b> when you select the GDUS Link 1 or Coriolis Link 1.
	<b>Stream</b> Select the stream to which to link the stream.
	<b>Address</b> Enter the address to which to link the stream.

**Notes:**

- If you select the Modbus (Master) function **and** the Ethernet or Modbus protocols, you must provide a slave IP address in addition to identifying the port.
- If you select the Modbus (Slave) function **and** the Ethernet or Modbus protocol, a **Secondary Link** check box appears at the bottom of the screen below the Address Map field. Select this option to indicate that the slave unit is on the secondary Ethernet port.



- If you select the Printer function for multiple tasks, all the tasks can have the Printer function.
- 

4. Once you are done configuring communications, click on the hierarchy menu. Config600 displays an Apply Changes dialog box.
5. Click **Yes** to apply the changes to the configuration file. The PCSetup screen redisplay.

### **4.10.2 Setting Up Peer-to-peer Options**

To set up peer-to-peer communication options, refer to *Appendix F, Peer-to-peer Link Communications*.

*[This page is intentionally left blank.]*

## Chapter 5 – Station Configuration

### In This Chapter

5.1	Station Flowrate Limits.....	5-2
5.2	Station Averaging Temperature & Pressure.....	5-4
5.3	Station Secondary Units Setup.....	5-6
5.4	Station Flow Switching.....	5-8
5.5	Station Gas Composition.....	5-10
5.6	Sampling .....	5-15
5.7	Prover Configuration Screens .....	5-18
5.7.1	Flow Balance Setup.....	5-18
5.7.2	Prover – Ball (Bi-Directional) (Liquid Only).....	5-20
5.7.3	Prover – Compact (Liquid Only).....	5-32
5.7.4	Prover – Master Meter (Gas and Liquid).....	5-45

Use Stations to provide functions, such as station totals, batching, flow switching, and proving. They may also provide a common point for chromatograph information, sampler output, header density measurement and the corresponding liquid volume correction calculations.

Streams can work stand alone, but you may also assign a stream to a station together with other streams. For example, stations can provide proving functions to streams you configure in other S600+ computers.

If you assigned streams to stations during the initial configuration process, then up to two stations appear as choices in the hierarchy menu in the left pane. The stations can be gas or liquid or one of each.

#### Notes:

- For station summation of stream flowrates to work correctly, all stations must have at least one stream configured.
- Some station settings affect stream settings.

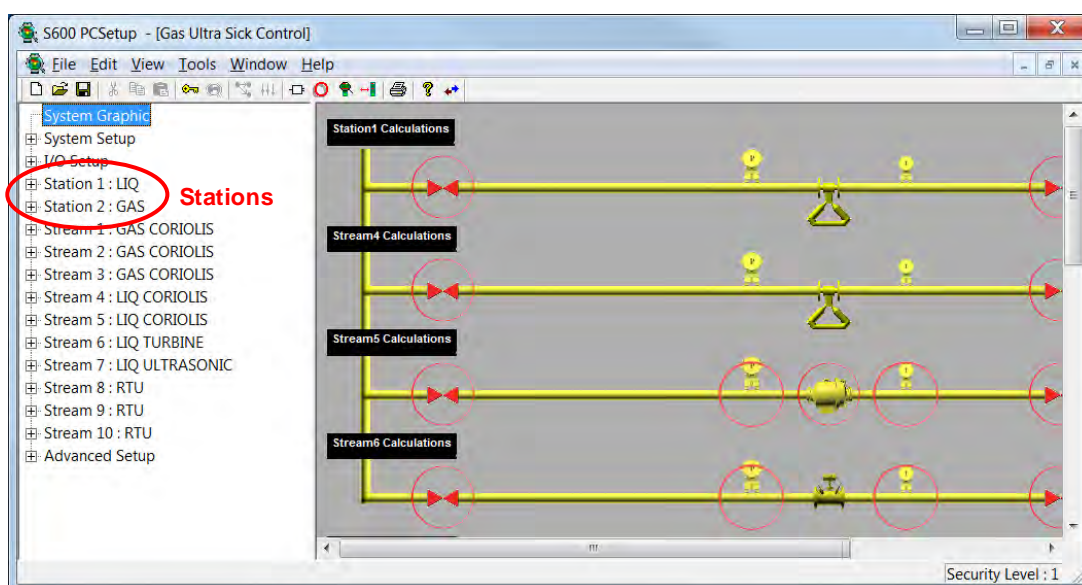

Figure 5-1. Stations on the Hierarchy Menu

Station settings for the S600+ allow the configuration to be organised according to the application’s operational requirements. The initial configuration process assigns default values to the station settings. Using the PCSetup Editor, you can define alarm limits for a maximum of two stations in each configuration file.

To edit the station settings, select the required station from the left pane (hierarchy menu) in the PCSetup Editor.

---

**Note:** You can also access and edit station settings through the System Editor and the System Graphic.

---

Station settings include:

---

<b>Common Station Settings</b>	<ul style="list-style-type: none"> <li>▪ Flow Rate Limits</li> <li>▪ Station Averaging</li> <li>▪ Secondary Units Station Setup</li> </ul>
<b>Gas Station Settings</b>	<ul style="list-style-type: none"> <li>▪ Flow Switching (Station)</li> <li>▪ Batching (Refer to Batching)</li> <li>▪ Density Measurement (Refer to Stream Configuration)</li> <li>▪ Chromatograph Data</li> </ul>
<b>Liquid Station Settings</b>	<ul style="list-style-type: none"> <li>▪ Product Table (Refer to Batching)</li> <li>▪ Batching (Refer to Batching)</li> <li>▪ Proving (Refer to Proving)</li> <li>▪ Flow Switching (Station)</li> <li>▪ Density Measurement (Refer to Stream Configuration)</li> <li>▪ Sampling</li> <li>▪ Liquid Volume Correction</li> <li>▪ Flow Balance Setup</li> </ul>

---

## 5.1 Station Flowrate Limits

---

Flowrate settings define the alarm setpoints for each type of flowrate. You can enable up to four types of alarms for each flowrate. The settings enable or disable the alarms, and are system-activated when the calculated result for the relevant flowrate is not within the limits you specify.

### Editing Flowrate Alarms

To edit or activate flowrate alarm settings:

1. Select the **Flowrate** component from the hierarchy menu. The system displays the associated settings in the right-hand pane.

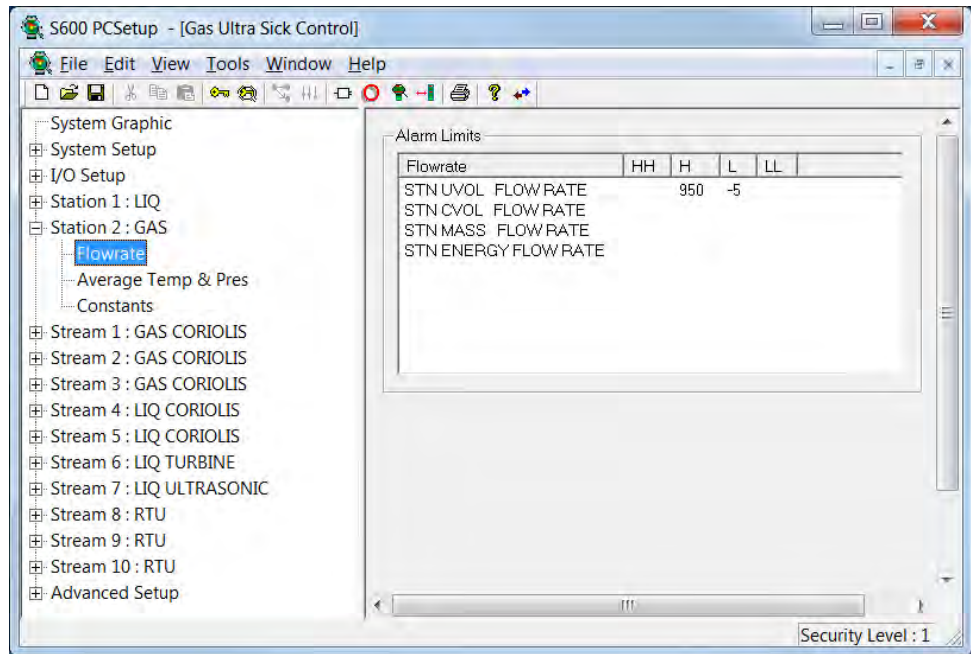

Figure 5-2. Flowrate Options

2. Double-click the required flowrate object. The system displays a Calculation Result dialog box.

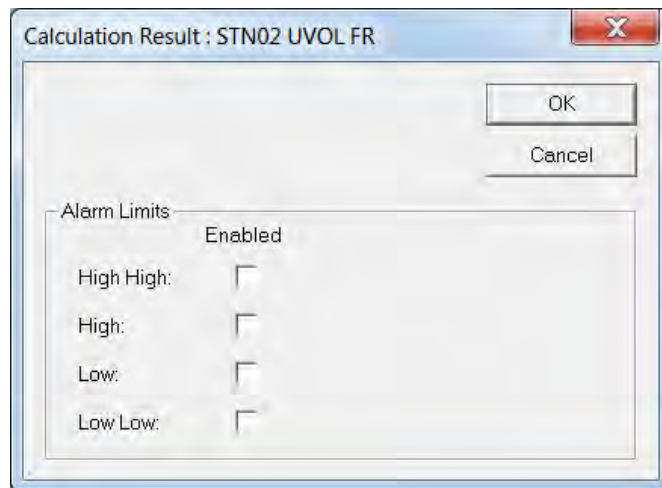

Figure 5-3. Calculation Result dialog box

3. Select one or more alarms to enable. The system adds limit fields and default values to the dialog box.

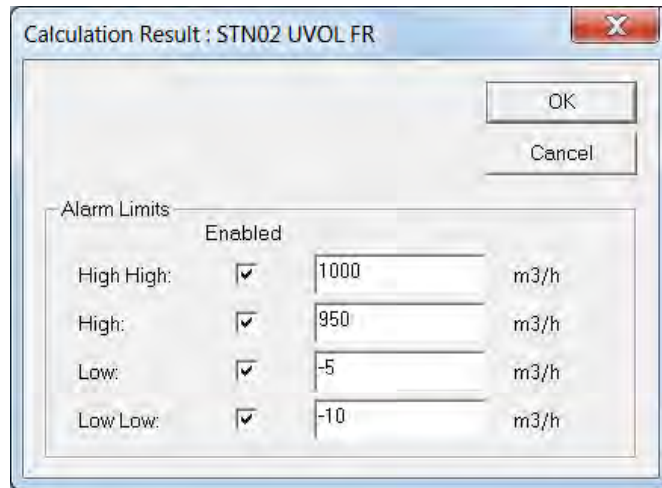

Figure 5-4. Calculation Result (with limits)

4. Review and modify the limits for any alarms you have enabled.
5. Click **OK** to apply the changes to the configuration file. The PCSetup screen displays your changes.

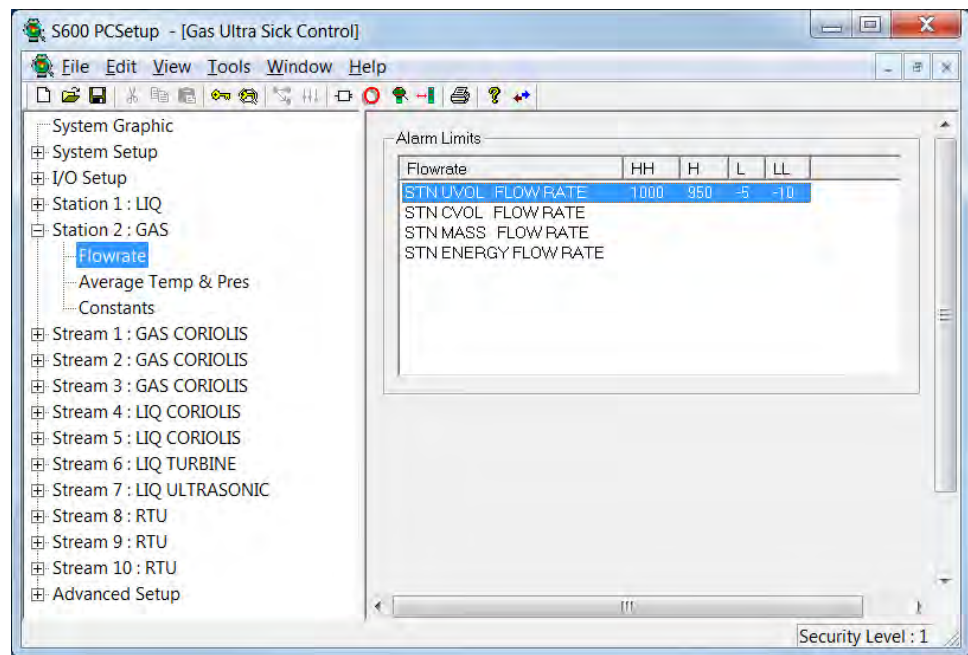

Figure 5-5. Flowrate Alarms with Limits

## 5.2 Station Averaging Temperature & Pressure

Use the Station Averaging settings to set the alarm limits of the average temperature and pressure and define how the S600+ performs averaging.

1. Select the **Average Temp & Pres** component from the hierarchy menu. The system displays the associated settings in the right-hand pane.

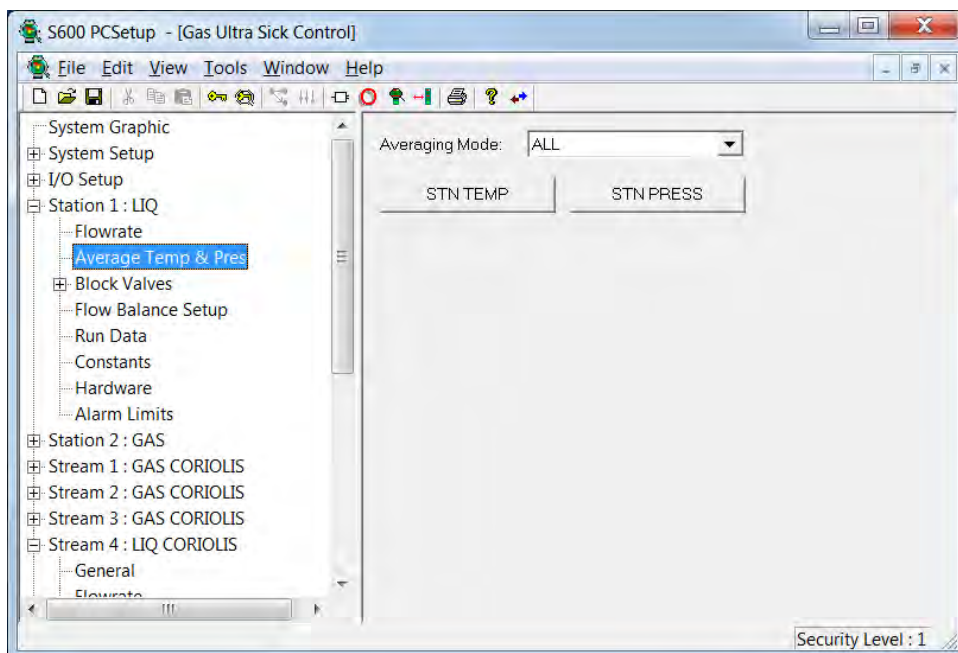

Figure 5-6. Average Temp & Pressure

2. Select an averaging mode. Click ▼ to display all valid options:

Value	Description
All	Average the pressure and temperature of all streams, regardless of status.
All Online	Average the pressure and temperature of only those streams currently on-line.
1st Online	Use the pressure and temperature of the first stream on-line as the average station pressure and temperature.

3. Click **STN TEMP** or **STN PRESS** to display a Calculation Result dialog box.

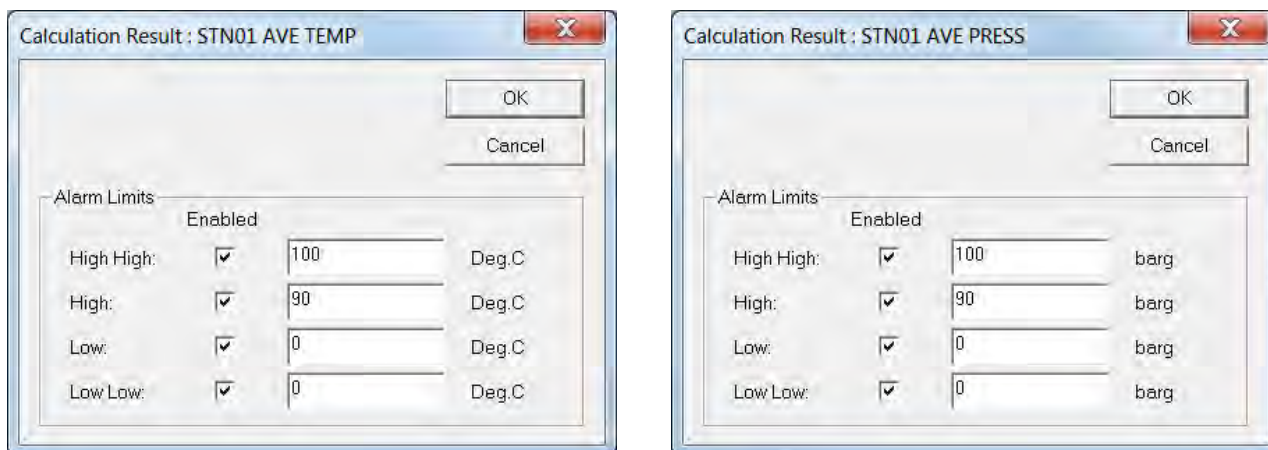

Figure 5-7. Calculation Result dialog box for Temp & Pressure

4. Select the appropriate alarms to enable and indicate the specific values (temperatures and pressure in pre-defined units) for each alarm.
5. Click **OK** to apply the changes. The PCSetup screen displays.

### 5.3 Station Secondary Units Setup

The station secondary units setup allows for the configuration of selected flow rates and totals in different units as selected in the unit's section.

1. Select the **Secondary Units STN Setup** component from the hierarchy menu. The system displays the associated settings in the right-hand pane.

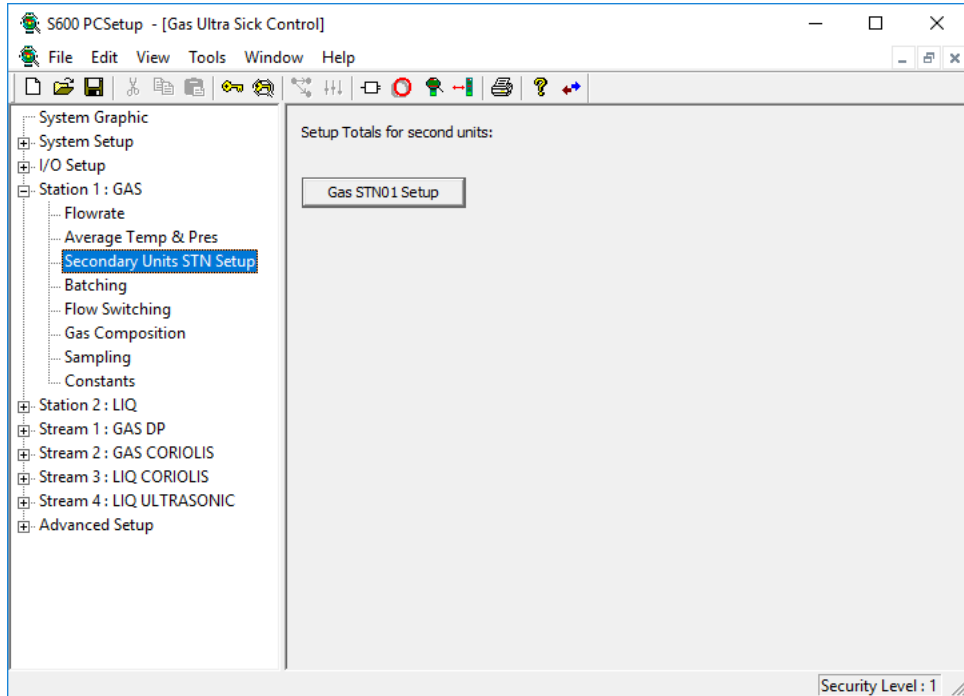

Figure 5-8. Secondary Units STN Setup

2. Select the **Gas STN Setup** or **Liquid STN Setup** button to display the Dual Units Setup dialog.

**Note:** The dialog box consists of two screens (Cumulative Totals and Periodic Totals). You can switch between each screen by selecting the **To Periodic Totals/To Cumulative Totals** button.



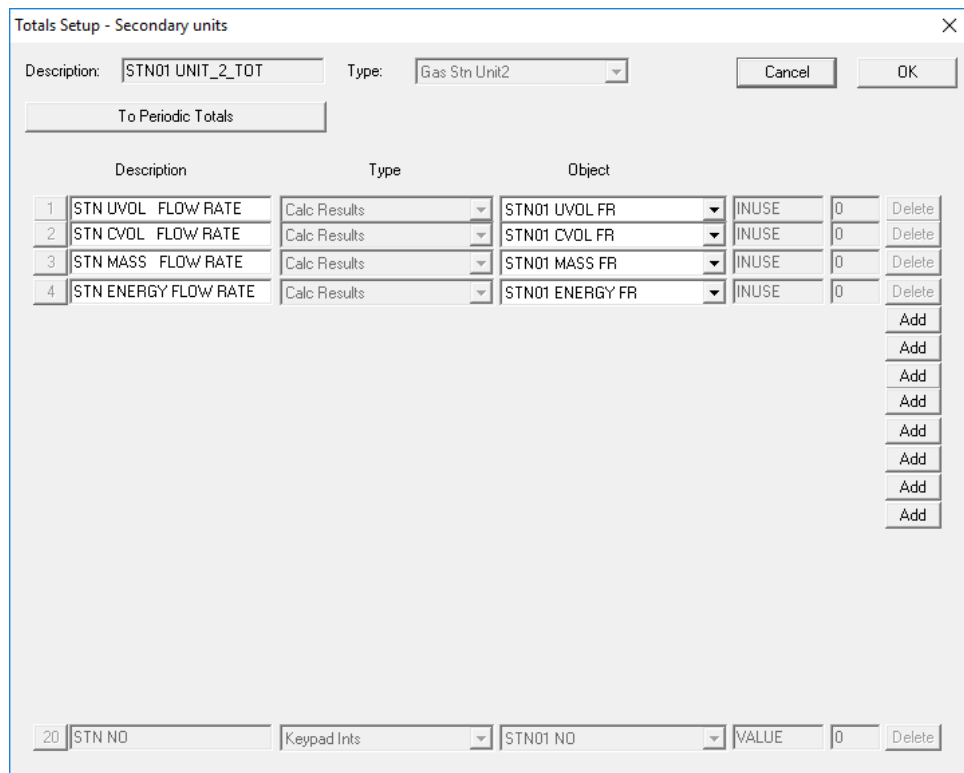

Figure 5-9. Dual Units Setup – Cumulative Totals dialog box

3. The Cumulative Totals screen consists of the following:
- The first 4 slots are pre-defined and indicate the available flow rates.
  - You can configure the next 8 slots as station cumulative totals.
  - The last slot is pre-defined and indicates which station is linked to the selected Dual Units Setup instance.

To add a cumulative total, click on the **Add** button, and the first available cumulative total appears. Use the ▼ button to change the cumulative total for each slot.

**Note:** You should **only** configure Station Cumulative Totals.

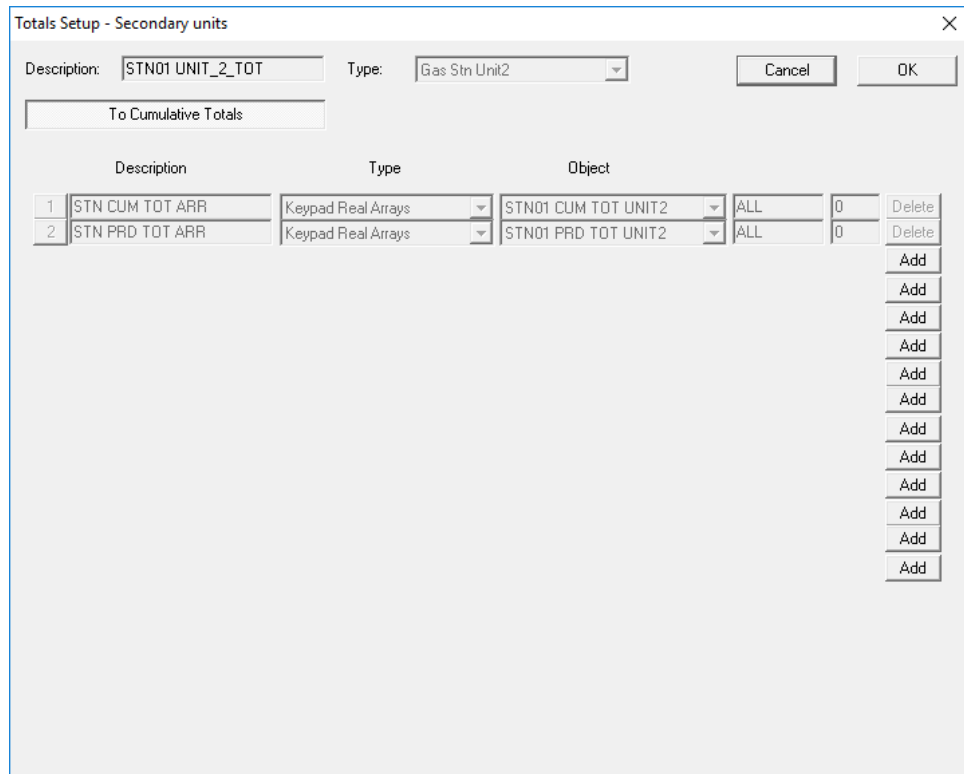

Figure 5-10. Dual Units Setup – Periodic Totals dialog box

4. Click the the **To Periodic Totals** button to view the Periodic Totals screen. The Periodic Totals screen consists of the following:
  - Pre-defined Slot 1 is **read-only** and indicates the converted flow rates and cumulative totals.
  - Pre-defined Slot 2 is **read-only** and indicates the converted periodic totals.
  - You can configure the next 12 slots as periodic totals.

To add a periodic total, click on the **Add** button. Use the ▼ button to select the required periodic total.

**Note:** You should **only** configure Periodic Totals belonging to the selected station.

5. Click **OK** to apply the changes. The PCSetup screen displays.

## 5.4 Station Flow Switching

Flow Switching settings define the method and parameters that determine which streams should open and close. You can set up flow switching for a station and then disable it until you need this option.

1. Select **Flow Switching** from the hierarchy menu. The Flow Switching screen displays.

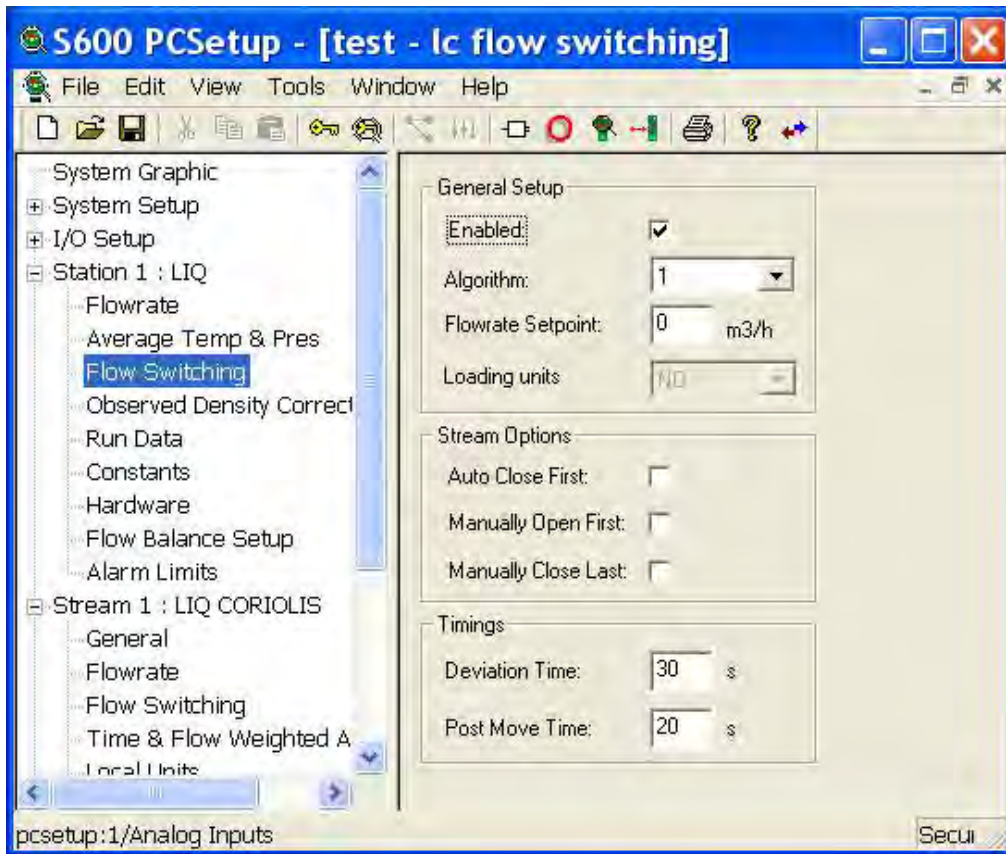

Figure 5-11. Flow Switching screen

2. Complete the following fields.

Field	Description
<b>Enabled</b>	Disables flow switching for the station. The default is checked (flow switching is <b>enabled</b> ).
<b>Algorithm</b>	Sets the algorithm to open and close streams. The default is 1. <b>Note:</b> Refer to <i>Appendix C, Batching</i> , for algorithm descriptions.
<b>Flowrate Setpoint</b>	Sets, if applicable, the required station flowrate.
<b>Loading Units</b>	Identifies whether the measured flowrate is Mass (=1) or Volume (=0) units. The default is Volume.
<b>Auto Close First</b>	Identifies whether to close highest priority stream first (checked) or to close lowest priority stream first. <b>Note:</b> This does not apply to Algorithm 1.
<b>Manually Open First</b>	Select to open the first stream manually.
<b>Manually Close Last</b>	Select to close the last stream manually.
<b>Deviation Time</b>	Sets the minimum time the flowrate must be above or below the limit before automatically opening or closing a stream.
<b>Post Move Time</b>	Sets a delay time after opening or closing a valve before moving to the monitor flow stage.

3. Click in the hierarchy menu when you finish defining settings. A confirmation dialog box displays.

- Click **Yes** to apply your changes. The PCSetup screen displays.

## 5.5 Station Gas Composition

Station Gas Composition settings define the processing and port telemetry parameters for stations receiving data from the gas chromatograph controller. The chromatograph controller measures the individual component concentrations found in the line gas. The chromatograph controller settings also allow you to define alarms. The system activates these alarms when the calculated results for the chromatograph data are not within specified limits.

- Select **Gas Composition** from the hierarchy menu. The Gas Composition screen displays.

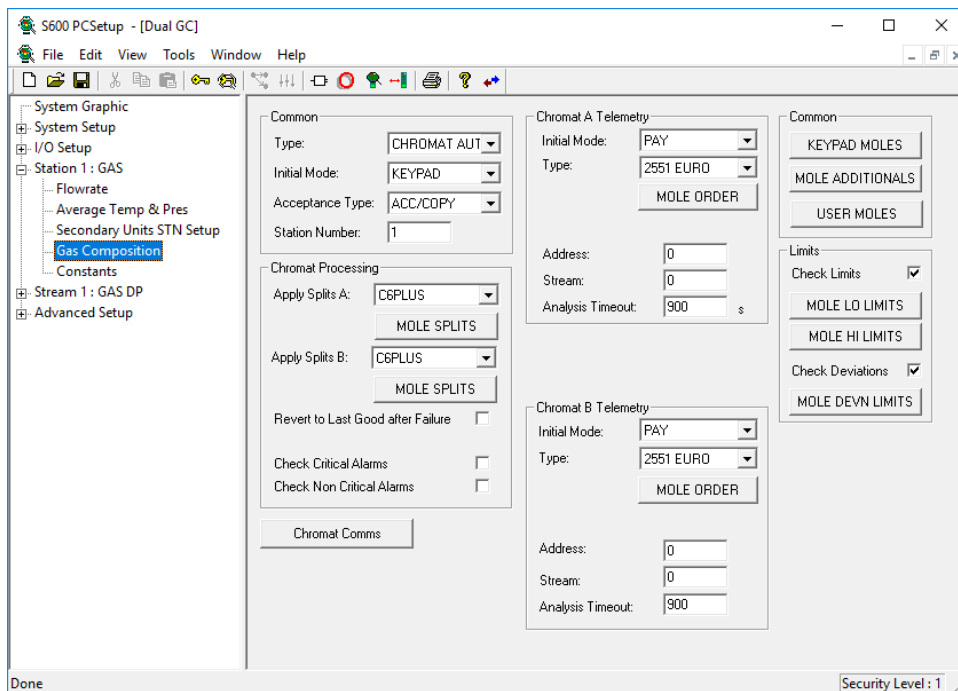

Figure 5-12. Station Gas Composition screen

- Complete the following fields.

Field	Description
<b>Type</b>	Indicates the chromatograph configuration. Click ▼ to display all valid values.
<b>KP ONLY</b>	Not controller-connected; uses information entered via keypad. This is the <b>default</b> . <b>Note:</b> If you select <b>KP ONLY</b> , the system hides a number of fields on this screen.
<b>CHROMAT A</b>	Controller connected; uses data from Chromatograph A. If a fault is detected on Chromatograph A, then the system uses data from Chromatograph B (if healthy) or keypad data / last good data as fallback.

Field	Description
	<p><b>CHROMAT B</b> Controller connected; uses data from Chromatograph B. If a fault is detected on Chromatograph B, then the system uses data from Chromatograph A (if healthy) or keypad data / last good data as fallback.</p>
	<p><b>CHROMAT AUTO</b> Controller connected; uses data from both Chromatographs based on the new analysis flag (GC A → GC B → GC A → GC B). If a fault is detected on one of the Chromatographs, then the data from the other is used. If a fault is detected on both Chromatographs, then the keypad data / last good data is used as fallback.</p>
<b>Initial Mode</b>	<p>Indicates the operational mode for the in-use composition data. Click ▼ to display all valid values.</p>
	<p><b>KEYPAD</b> Use data entered via keypad. This is the <b>default</b>.</p>
	<p><b>CHROMAT</b> Use live data from the chromatograph controller.</p>
	<p><b>DOWNLOAD</b> Download gas composition data directly to each stream. Used only if connected to a remote supervisory computer.</p>
	<p><b>USER</b> Use customised program for gas composition in S600+.</p>
	<p><b>KEYPAD_F</b> Start by using keypad-entered data then switch to chromatograph data when a good analysis is received.</p>
<b>Acceptance Type</b>	<p>Indicates how the S600+ manages in-use data. Click ▼ to display all valid values.</p>
	<p><b>ACC/COPY</b> Copy and normalise keypad data to in-use data only after it is accepted. This is the <b>default</b>.</p>
	<p><b>ACC/NORM</b> Copy normalised keypad data to in-use data after it is accepted.</p>
	<p><b>AUTO/NORM</b> Automatically copy normalised keypad data to in-use data.</p>
<b>Station Number</b>	<p>Sets the station associated with this stream. The default is 1.</p>
<b>Apply Splits</b>	<p>Indicates the type of analyser connected to the S600+. For a C6+ analyser, use the C6Plus option. Click ▼ to display all valid values. The default is <b>NO SPLITS</b>. If you select any value other than <b>NO SPLITS</b>, the system displays the <b>MOLE SPLITS</b> button. Use it to define the specific percentage splits for the gases.</p> <p><b>Note:</b> This field displays <b>only</b> if you selected <b>CHROMAT A</b>, <b>CHROMAT B</b>, or <b>CHROMAT AUTO</b> as the chromatograph configuration type.</p>
<b>Revert to Last Good after Failure</b>	<p>Continues using the last good composition in the event of failure. Otherwise, the system reverts to keypad data.</p>

<b>Field</b>	<b>Description</b>
<b>Check Critical Alarms</b>	<p>Marks the received composition as failed if any critical alarm is set (such as the pre-amp fail on the Danalyzer for a Daniel 2551 Controller).</p> <p><b>Note:</b> This field displays <b>only</b> if you selected <b>CHROMAT A</b>, <b>CHROMAT B</b>, or <b>CHROMAT AUTO</b> as the chromatograph configuration type.</p>
<b>Check Non Critical Alarms</b>	<p>Marks the received composition as failed if any non-critical alarm is set (such as the pre-amp fail on the Danalyzer for a Daniel 2551 Controller).</p> <p><b>Note:</b> This field displays <b>only</b> if you selected <b>CHROMAT A</b>, <b>CHROMAT B</b>, or <b>CHROMAT AUTO</b> as the chromatograph configuration type.</p>
<b>CHROMAT COMMS</b>	Click to display the Comm screen in I/O Setup.
<b>Initial Mode</b>	<p>Identifies the chromatograph and any fallback controllers. Currently, the only valid value is <b>PAY</b>, which indicates one chromatograph and no fallback controller.</p> <p><b>Note:</b> This field displays <b>only</b> if you selected <b>CHROMAT A</b>, <b>CHROMAT B</b>, or <b>CHROMAT AUTO</b> as the chromatograph configuration type.</p>
<b>Type</b>	<p>Indicates the type of chromatograph controller. Click ▼ to display all valid values.</p> <p><b>Note:</b> This field displays <b>only</b> if you selected <b>CHROMAT A</b>, <b>CHROMAT B</b>, or <b>CHROMAT AUTO</b> as the chromatograph configuration type.</p>
<b>2551 EURO</b>	S600+ is connected to a Daniel 2551 (European) controller. This is the <b>default</b> .
<b>2350 EURO</b>	S600+ is connected to a Daniel 2350 (European) controller set in SIM_2251 mode.
<b>2350 USA</b>	S600+ is connected to a Daniel 2350 (USA) controller set in SIM_2251 mode.
<b>2251 USA</b>	S600+ is connected to a Daniel 2251 controller.
<b>Generic</b>	S600+ is connected to another type of controller.
<b>Siemens</b>	S600+ is connected to a Siemens Advance Maxum via a Siemens Network Access Unit (NAU).

Field	Description
<b>MOLE ORDER</b>	<p>Click this button to display a dialog box on which you indicate the order in which the gas composition information comes into the S600+ via telemetry. <b>0</b> indicates any component which is <b>not</b> included in the Modbus map.</p> <p><b>Note:</b></p> <ul style="list-style-type: none"> <li>▪ The Modbus map you create must be compatible with the controller to which the S600+ is connected. Refer to <i>Chapter 14, Modbus Editor</i>, for further information.</li> <li>▪ This field displays <b>only</b> if you selected <b>CHROMAT A</b>, <b>CHROMAT B</b>, or <b>CHROMAT AUTO</b> as the chromatograph configuration type.</li> <li>▪ This is applicable <b>only</b> if you select <b>Siemens</b> or <b>Generic</b> in the Type field.</li> </ul>
<b>Address</b>	<p>Configures multi-drop chromatograph support. <b>Do not change unless advised to do so.</b></p> <p><b>Note:</b> This field displays <b>only</b> if you selected <b>CHROMAT A</b>, <b>CHROMAT B</b>, or <b>CHROMAT AUTO</b> as the chromatograph configuration type.</p>
<b>Stream</b>	<p>Sets the chromat analysis stream assigned to this metering stream. The default is <b>0</b>.</p> <p><b>Note:</b> This field displays <b>only</b> if you selected <b>CHROMAT A</b>, <b>CHROMAT B</b>, or <b>CHROMAT AUTO</b> as the chromatograph configuration type. If you need to support more than one stream, contact Technical Support.</p>
<b>Analysis Timeout</b>	<p>Sets the maximum number of seconds the S600+ waits to receive a new composition from the chromatograph controller before raising an alarm. The default is <b>900</b>.</p> <p><b>Note:</b> This field displays <b>only</b> if you selected <b>CHROMAT A</b>, <b>CHROMAT B</b>, or <b>CHROMAT AUTO</b> as the chromatograph configuration type.</p>
<b>Download Timeout</b>	<p>Sets the maximum number of minutes the S600+ waits to receive a new composition from the supervisory computer before raising a <b>DL Timeout Alarm</b>. The default is <b>15</b>.</p> <p><b>Note:</b></p> <ul style="list-style-type: none"> <li>▪ A value of <b>0</b> disables the timeout.</li> <li>▪ This field displays <b>only</b> if you select <b>KP ONLY</b> in the Type field.</li> </ul>
<b>KEYPAD MOLES</b>	<p>Click to display a dialog box you use to define mole percentage values for each gas component.</p> <p><b>Note:</b> The system assumes the keypad composition adds to 100% (normalised) when the Acceptance Type is ACC/COPY. If you select <b>ACC/NORM</b> or <b>AUTO/NORM</b>, the system automatically normalises the keypad composition.</p>

<b>Field</b>	<b>Description</b>
<b>MOLE ADDITIONAL</b>	<p>Click to display a dialog box you use to define mole percentage values for gas components not analysed by the Danalyzer. The system assumes any additional components to be normalised values, so the analyser components are re-normalised to (100 – sum of additional components).</p> <p><b>Note:</b> This field displays <b>only</b> if you selected <b>CHROMAT A</b>, <b>CHROMAT B</b>, or <b>CHROMAT AUTO</b> as the chromatograph configuration type.</p>
<b>USER MOLES</b>	<p>Click to display a dialog box you use to define mole percentage values for each gas component. The system assumes user moles to be normalised.</p> <p><b>Note:</b> The S600+ uses these values <b>only</b> if you set the Initial Mode to <b>USER</b>. A Modbus download from another computer may overwrite these values on a running configuration.</p>
<b>Check Limits</b>	<p>Enables limit checking on each gas component. When you select this check box, the <b>MOLE LO LIMITS</b> and <b>MOLE HI LIMITS</b> buttons display.</p>
<b>MOLE LO LIMITS</b>	<p>Click to display a dialog box you use to define low mole percentage limit values for each gas component. Enter <b>0</b> in any field to prevent the test for the selected component.</p> <p><b>Note:</b></p> <ul style="list-style-type: none"> <li>▪ The system uses the values you enter through these buttons <b>only</b> if you select the Check Limits check box. The system applies this test to the keypad, downloaded, user, additional, and new analysis components. When enabled, the system applies the limit check against the high and low limits. Limits are considered valid if the limit is greater than zero (0). The system also applies the check to the Total field. If you <b>disable</b> the limit check, the keypad, downloaded, and user Total field must lie within 0.1% and 150%. A sum of the new analysis must be within 99.5% and 100.5%.</li> <li>▪ This field displays <b>only</b> if you place a check mark in the Check Limits field.</li> </ul>
<b>MOLE HI LIMITS</b>	<p>Click to display a dialog box you use to define high mole percentage limit values for each gas component. Enter <b>0</b> in any field to prevent the test for the selected component.</p> <p><b>Note:</b> See note in description of Mole Lo Limits field.</p>
<b>Check Deviations</b>	<p>Enables checking on the deviation from the last good analysis for each component. When you select this check box, the <b>MOLE DEVN LIMITS</b> button displays.</p> <p><b>Note:</b> This field displays <b>only</b> if you selected <b>CHROMAT A</b>, <b>CHROMAT B</b>, or <b>CHROMAT AUTO</b> as the chromatograph configuration type.</p>
<b>MOLE DEVN LIMITS</b>	<p>Displays a dialog box you use to define the maximum deviation allowed for each gas component. Enter <b>0</b> in any field to prevent the test for the selected component.</p> <p><b>Note:</b> This field displays <b>only</b> if you place a check mark in the Check Deviations field.</p>



3. Click in the hierarchy menu when you finish defining settings. A confirmation dialog box displays.
4. Click **Yes** to apply your changes. The PCSetup screen displays.

## 5.6 Sampling

---

Sampling defines the method and interval period for sampling product from a flowing pipeline. By default, Config600 supports one sampler per stream. Config600 uses the following stages during the sampling process:

Stage	Description
0	Idle
1	Monitor
2	Digout n
3	Min Intvl
4	Post Pulse
5	Stopped Manually
6	Stopped Can Full
7	Stopped Low Flow
8	Initial Time
9	Check Flow Switch
10	Stopped Flow Switch
11	Stopped Press Switch
12	Stopped Initialise
13	Can Switch Over

1. Select **Sampling** from the hierarchy menu. The system displays the associated settings in the right-hand pane.

---

**Note:** Batch auto-resets the sampler at the start of the batch.

---

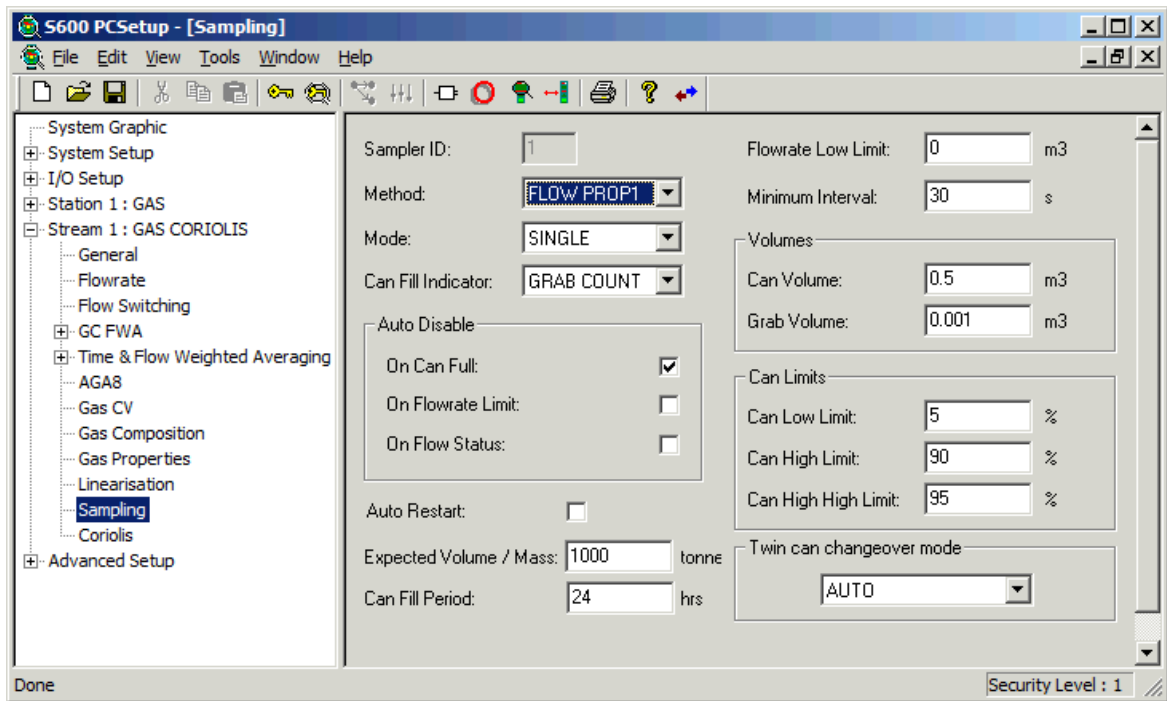

Figure 5-13. Station Sampling

2. Complete the following fields:

Field	Description								
<b>Sampler ID</b>	Provides an identifying label for the sampler. Each stream or station must have a unique sampler ID. This value, which must be greater than 0, is for identification purposes only and is not used in any calculation.								
<b>Method</b>	Identifies a sampling method. Click ▼ to display valid values. <table border="1" style="width: 100%; margin-top: 5px;"> <tbody> <tr> <td><b>Time Prop</b></td> <td>Divides the value in the Can Fill Period field by the number of grabs needed to fill the can (derived from the Can Volume and Grab Volume values) to determine a time interval per pulse. This is the <b>default</b>.</td> </tr> <tr> <td><b>Flow Prop1</b></td> <td>Divides the value in the Expected Volume/Mass field by the number of grabs needed to fill the can (derived from the Can Volume and Grab Volume values) to determine a volume throughput per pulse.</td> </tr> <tr> <td><b>Flow Prop2</b></td> <td>Uses the value in the Expected Volume/Mass field as the volume throughput per pulse.</td> </tr> <tr> <td><b>Flow Prop3</b></td> <td>Uses the value in the Expected Volume/Mass field as the volume throughput per pulse, but supports low pressure digital input and pump prime output.</td> </tr> </tbody> </table>	<b>Time Prop</b>	Divides the value in the Can Fill Period field by the number of grabs needed to fill the can (derived from the Can Volume and Grab Volume values) to determine a time interval per pulse. This is the <b>default</b> .	<b>Flow Prop1</b>	Divides the value in the Expected Volume/Mass field by the number of grabs needed to fill the can (derived from the Can Volume and Grab Volume values) to determine a volume throughput per pulse.	<b>Flow Prop2</b>	Uses the value in the Expected Volume/Mass field as the volume throughput per pulse.	<b>Flow Prop3</b>	Uses the value in the Expected Volume/Mass field as the volume throughput per pulse, but supports low pressure digital input and pump prime output.
<b>Time Prop</b>	Divides the value in the Can Fill Period field by the number of grabs needed to fill the can (derived from the Can Volume and Grab Volume values) to determine a time interval per pulse. This is the <b>default</b> .								
<b>Flow Prop1</b>	Divides the value in the Expected Volume/Mass field by the number of grabs needed to fill the can (derived from the Can Volume and Grab Volume values) to determine a volume throughput per pulse.								
<b>Flow Prop2</b>	Uses the value in the Expected Volume/Mass field as the volume throughput per pulse.								
<b>Flow Prop3</b>	Uses the value in the Expected Volume/Mass field as the volume throughput per pulse, but supports low pressure digital input and pump prime output.								
<b>Mode</b>	Indicates the sampling mode. Valid values are <b>Single</b> (acquire sample in one can) or <b>Dual</b> (acquire sample in two cans). The default value is Single. <b>Note:</b> If you select <b>Dual</b> , the sampler switches to a second can when the current can is full (according to the twin can changeover mode).								

Field	Description
<b>Can Fill Indicator</b>	Determines when the sampling can is full. Click ▼ to display valid values.
	<b>Grab Count</b> Uses the number of pulses output to the sample to determine when the can is full. This is the default.
	<b>Dig I/P</b> Uses a digital input to determine when the can is full.
	<b>Analog I/P</b> Uses an analog input to determine when the can is full.
<b>Auto Disable</b>	Indicates the event at which the system automatically disables the sampling process. Select one of the check boxes to identify the event.
	<b>On Can Full</b> Disables the sampling process when the can is full.
	<b>On Flowrate Limit</b> Disables the sampling process when the flowrate is less than the value of the Flowrate Low Limit.
	<b>On Flow Status</b> Disables the sampling process when the flow status value is not on-line.
<b>Auto Restart</b>	Automatically restarts the sampling process following an automatic disabling.
<b>Expected Volume / Mass</b>	Indicates, in cubic meters, the flow volume or mass during which the samples are to be taken. This is the value the Flow Prop1 and Flow Prop2 sampling methods use for their calculations. The default is <b>1000</b> .
<b>Can Fill Period</b>	Indicates, in hours, the amount of time required to fill the sampling can. This is the value the Time Prop sampling method uses for its calculations. The default is <b>24</b> . <b>Note:</b> This field is required for the TIME PROP sampling method.
<b>Flowrate Low Limit</b>	Indicates, in cubic meters, the flowrate limit for the Auto Disable on Flowrate option. The default is <b>0</b> . <b>Note:</b> This field is required if you select the On Flowrate Limit check box for Auto Disable.
<b>Minimum Interval</b>	Indicates, in seconds, the minimum amount of time between grabs. This is the value the Time Prop sampling method uses for its calculations. The default is <b>30</b> . <b>Note:</b> If the sample exceeds this limit, the system sets the overspeed alarm and increments the overspeed counter.
<b>Can Volume</b>	Indicates, in cubic meters, the volume of the sampling can. The default is <b>0.5</b> .
<b>Grab Volume</b>	Indicates, in cubic meters, the volume of the sampling grab. The default is <b>0.001</b> .
<b>Can Low Limit</b>	Indicates the low alarm value as a percentage of the can volume. The default is <b>5</b> .
<b>Can High Limit</b>	Indicates the high alarm value as a percentage of the can volume. The default is <b>90</b> .
<b>Can High High Limit</b>	Indicates the high high alarm value as a percentage of the can volume. The default is <b>95</b> .
<b>Twin can changeover mode</b>	Indicates whether the system automatically changes to a second sampling can. Click ▼ to display valid values.

3. Click the hierarchy menu when finished. A confirmation dialog box displays.
4. Click **Yes** to apply your changes. The PCSetup screen displays.

## 5.7 Prover Configuration Screens

---

This section provides an overview of the four S600+-supported proving methods—bi-directional, uni-directional, compact, and master meter—and their specifications and applications.

---

**Note:** Refer to *Appendix B, Proving*, for additional information.

---

The uni-directional prover differs from the bi-directional prover only in the run control sequence described in *Prover Run Control Stages*.

**Station Based** With release 3.0 of Config600 software, proving is a **station-based** function. Each S600+ can support two stations, and you can assign up to 10 streams (depending on the complexity of the configured streams) to each station. The provers do not need to be the same type. However, the S600+ supports only one Prover (P154) module, which means that you can perform only one prove sequence at a time.

You can configure the streams to be proved either internally (within the same S600+) or externally in other S600+ flow computers (using a Modbus communication link to transfer process data to the prover). The S600+ does not provide an option supporting both internal and external streams in one configuration.

You select the prover type when building the configuration with the PCSetup Wizard.

**Local or Remote** The software also allows you to prove streams that are “local” (that is, part of the same configuration) or prove streams that are “remote” (in a separate configuration or separate S600+) to the prover.

However, you cannot mix the two (for example, have a prover config with three metering streams and prove a remote, separate stream). If you require this feature, contact technical support.

### 5.7.1 Flow Balance Setup

Use flow balancing in conjunction with proving to regulate the flow through the meters to maintain a set flowrate through the prover.

The objective is to distribute the flow evenly across available streams. If the overall flowrate through the skid increases, flow balancing can open another meter run, or if the flow reduces the flow balancing, it can close a meter run to maintain an optimum flowrate through each meter.

You can open and close meter runs by configuring the streams to open and close valves.

1. Select **Flow Balance Setup** from the hierarchy menu. The system displays Flow Balance settings in the right-hand pane.

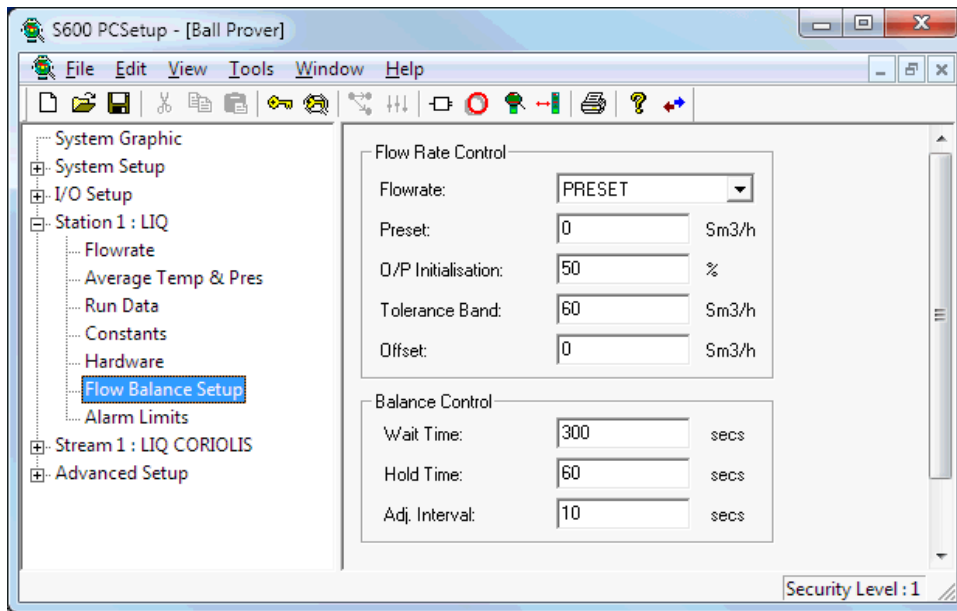

Figure 5-14. Flow Balance Setup screen

2. Complete the following fields:

Field	Description
<b>Flow Rate</b>	Select the source of the proof flowrate. Valid values are <b>Preset</b> (sets the proof flowrate to the Preset data field value plus the Offset data field value) or <b>Snapshot</b> (sets the proof flowrate to a snapshot of the stream under prove flowrate plus the Offset data field value). The default is <b>Preset</b> .
<b>Preset</b>	Sets the proof flowrate.
<b>O/P Initialisation</b>	Sets the initial manual mode output position for the prover flow control valve. The default value is <b>50</b> .
<b>Tolerance Band</b>	Sets the tolerance for the deviation of the prover flowrate and its setpoint during the prove. The prove aborts if this value is exceeded. The default value is <b>60</b> .
<b>Offset</b>	Sets a flowrate to be added to the proof flowrate to offset the change in flowrate between the prover and the stream under prove. The default value is <b>0</b> .
<b>Wait Time</b>	Sets, in seconds, how long the S600+ waits for the proof flowrate to achieve before moving to the hold stability stage. The default value is <b>300</b> .
<b>Hold Time</b>	Sets, in seconds, how long the S600+ holds the proof flowrate before starting prover runs. The default value is 60. <b>Note:</b> S600+ aborts the prover sequence if stability is lost during the stability Hold Time.
<b>Adj. Interval</b>	Sets a time interval between making successive adjustments to the non-proving streams flowrate.

Field	Description
<b>PID Loop</b>	<p>Sets the PID loop you use to control the flowrate at the prover. Click ▼ to display valid options. The default is None.</p> <p><b>Notes:</b></p> <ul style="list-style-type: none"> <li>▪ This field displays <b>only</b> if you have configured a PID Control calctable or used the PRV01 CNTRL 1 and PRV01 CNTRL 2 by changing type to PID Control.</li> <li>▪ You define flowrate band settings for each stream on the Flowrate screen.</li> </ul>

## 5.7.2 Prover – Ball (Bi-Directional) (Liquid Only)

Two components enable you to control the prove:

- **Prove sequence** – Station-based function which sets up the prove environment.
- **Run control** – Prover-based function that drives the 4-way valve, counts pulses, and performs the K-factor calculations.

Following a successful prove, the system verifies the stream normal flow rate value:

- If the normal flow rate is set to a value greater than zero (**Aramco-style linearisation**), the run control waits for a predefined amount of time for you to reject the current prove results. If a prove is rejected, the proving report is annotated as "ABORTED". If the time-out elapses, the prove sequence downloads the prove results to the stream being proved and the data is automatically used in the subsequent calculations.
- If the normal flow rate is zero (**non-Aramco-style linearisation**), the prove sequence downloads the prove results to the stream being proved but does not use the data until it is accepted either locally at the S600+ or via a supervisory computer.

When the prove runs complete, you can either re-run the prove or terminate, at which point (if so configured) the sequence restores the valves to their pre-prove state.

---

**Notes:**

- The prove sequence downloads both a K-factor and a meter factor. Applications typically use the original K-factor from the meter calibration report and update the meter factor, which may be either a fixed value or derived from a linearisation process. Alternatively, the meter factor can remain unchanged, and the K-factor (fixed or linearised) updated.
- The meter factor deviation tests and the historical meter factor database are only supported for "local" streams (part of the same configuration with the prover) if you configure the stream normal flow rate to a value greater than zero.
- You define a ticket as Official or Unofficial when you configure a prove. This selection applies to both the Aramco-style and non-Aramco-style linearisation.

Following an **Official** prove, the prove sequence is determined by the Aramco / non-Aramco style linearisation selection.

Following the **Unofficial** prove, the prove sequence does not download the prove results to the stream being proved. This is typically used to determine an approximate K-Factor / Meter Factor before an official prove takes place or when maintenance activities are being performed on the site.

The Official/Unofficial selection displays in the report header.

**Run Data** Run Data settings allow you to define the prover stability check variables, the number of prove runs from which the system can calculate a K-factor/meter factor, and the tolerances allowed on the K-factor/meter factor. Once the S600+ completes a prove and calculates these values, you can select a new K-factor or meter factor to replace the current K-factor or meter factor.

To edit the prover run data settings:

1. Select **Run Data** from the hierarchy menu. The Run Data screen displays.

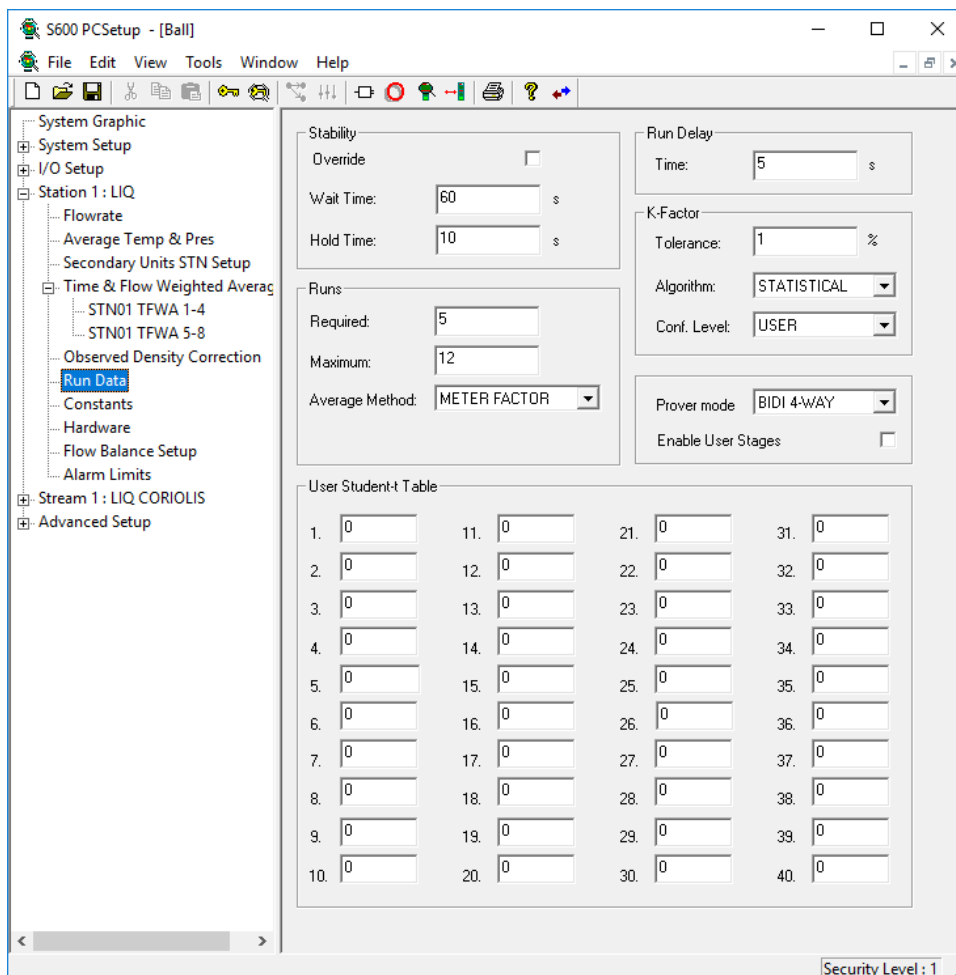

Figure 5-15. Run Data screen (Ball Prover)

2. Complete the following fields.

Field	Description
<b>Override</b>	Disables temperature and pressure stability checking. The default is unchecked (stability checking is <b>enabled</b> ). <b>Note:</b> If you <b>do not</b> enable this option, you <b>must</b> complete the Wait Time and Hold Time fields.
<b>Wait Time</b>	Sets, in seconds, how long the S600+ waits for stability before moving to the hold stability prover stage. The default is <b>60</b> .
<b>Hold Time</b>	Sets, in seconds, how long the S600+ holds stability before starting prover runs. The default is <b>10</b> . <b>Note:</b> The S600+ aborts the prover run if stability is lost during the stability hold time.
<b>Required</b>	Sets the required number of consecutive runs which must be within the defined tolerance limits (typically, 5). The default is <b>5</b> . <b>Note:</b> It is possible that the number of required runs cannot be achieved before the maximum number of runs reached. In this situation, the user can either wait for the prove to abort (once the maximum number of runs has been reached) or perform a manual abort.
<b>Maximum</b>	Sets the maximum number of runs to perform before aborting the sequence (up to 12 for the S600+). The default is <b>12</b> .
<b>Average Method</b>	Indicates the value to determine the repeatability and to indicate whether the final K-factor and meter factor are taken as the average of the run values, or are recalculated. Click ▼ to display valid values.
	<b>METER FACTOR</b> Use the run Meter Factors for repeatability and the average Meter Factor as the final value. The default is <b>METER FACTOR</b> .
	<b>K-FACTOR</b> Use the run K-factors for repeatability and the average K-factor as the final value.
	<b>PULSES</b> Use the run pulse counts for repeatability. This option also signifies to recalculate the final K-factor and Meter Factor using the average pulse count and other average values. See API Ch.12 Section 2 part 3.
<b>Time</b>	Sets, in seconds, the amount of time either between forward and reverse prover runs or between full prover runs. The default is <b>5</b> .
<b>Tolerance</b>	Sets, as a percentage, the maximum deviation allowed before a run is unacceptable. The default is <b>1</b> .
<b>Algorithm</b>	Indicates the algorithm the system uses to calculate the K-factor tolerance. Click ▼ to display valid values.
	<b>API I</b> API method: max deviation from (Average – Run) / Average. This is the <b>default</b> .
	<b>MX-MN/AVG</b> (Max – Min) / Average
	<b>MX-MN/MX+MN2</b> (Max – Min) / ((Max + Min) / 2)
	<b>MX-MN/MN</b> (Max – Min) / Min



Field	Description
	<b>MX-MN/MX*MN</b> (Max – Min) / (Max * Min)
	<b>MX-AV/AV</b> (Max – Average) / Average
	<b>AV-MN/AV</b> (Average – Min) / Average
	<b>STATISTICAL</b> Calculates the statistical k-factor deviation using a Student-t table distribution.
<b>Conf. Level</b>	Sets the confidence level for a two-sided Student-t table used in statistical proving. Click ▼ to display valid values. For more information, see <i>Appendix B, Proving</i> . <b>Note:</b> This field displays <b>only</b> if you select <b>STATISTICAL</b> in the Algorithm field.
<b>Prover mode</b>	Indicates the prover mode. Click ▼ to display valid values. <b>BIDI 4-WAY</b> Bi-directional prover mode. This is the <b>default</b> . <b>UNI ROTORK</b> Uni-directional prover using a ROTORK valve. <b>UNI TYPE 2</b> Uni-directional prover with no valve driving and assumes an external valve controller.
<b>Enable User Stages</b>	Enables Logicalc user stages. The default is unchecked (user stages are <b>disabled</b> ).
<b>User Student-t Table</b>	Indicates the Student-t table values for degrees of freedom 1-40. For more information, see <i>Appendix B, Proving</i> . <b>Note:</b> These fields display <b>only</b> if you select <b>STATISTICAL</b> in the Algorithm field <b>and</b> <b>USER</b> in the Confidence Level field.

3. Click in the hierarchy menu when you finish defining settings. A confirmation dialog box displays.
4. Click **Yes** to apply your changes. The PCSetup screen displays.

**Constants** The Constants screen has two major areas. One area (consisting of the Stability R.O.C, Stability Bands, and Base Volume panes) defines stability checking parameters. The other area (consisting of the Reference, Setup, and Misc panes) provides set-up information for the prover, including reference conditions and physical properties.

1. Select **Constants** from the hierarchy menu. The Constants screen displays.

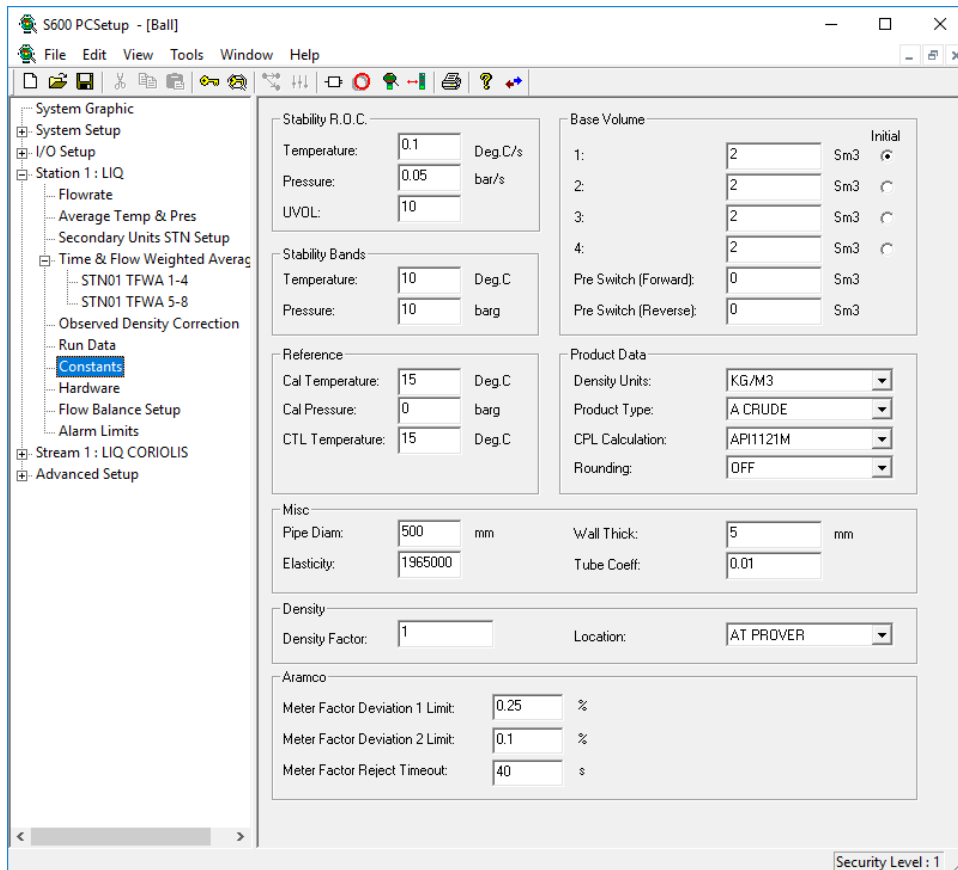

Figure 5-16. Constants screen (Ball Prover)

2. Complete the following fields.

Field	Description
<b>Temperature (Stability R.O.C.)</b>	Sets, in seconds, the Rate of Change (ROC) threshold limit for temperature, which the S600+ uses to check the ROC between the inlet, the outlet, and the meter. The default is <b>0.1</b> .
<b>Pressure (Stability R.O.C.)</b>	Sets, in seconds, the Rate of Change (ROC) threshold limit for pressure, which the S600+ uses to check the ROC between the inlet, the outlet, and the meter. The default is <b>0.5</b> .
<b>UVOL</b>	Sets, in seconds, the Rate of Change (ROC) threshold limit for the stream uncorrected volume (UVOL) flowrate. The default is <b>10</b> .
<b>Temperature (Stability Bands)</b>	Sets the maximum temperature difference between the inlet, the outlet, and the meter. The default is <b>10</b> .
<b>Pressure (Stability Bands)</b>	Sets the maximum pressure difference between the inlet, the outlet, and the meter. The default is <b>10</b> .
<b>Base Volume 1 through 4</b>	Sets the calibration volume (base volume) between the relevant sphere switches. <b>Note:</b> <ul style="list-style-type: none"> <li>Click <b>Initial</b> to identify the required base volume. <b>These values are critical to the calculations.</b></li> <li>The base volume should be entered as twice the calibrated volume (i.e., the round-trip volume).</li> </ul> Valid values are:

Field	Description
<b>1</b>	Defines the calibration volume between sphere switches 1 and 3. The default is <b>1</b> .
<b>2</b>	Defines the calibration volume between sphere switches 2 and 4.
<b>3</b>	Defines the calibration volume between sphere switches 1 and 4.
<b>4</b>	Defines the calibration volume between sphere switches 2 and 3.
<b>Pre Switch (Forward)</b>	Sets the forward pre-run volume (that is, the volume before switch 1). The default is <b>0</b> . <b>Note:</b> Set this field to zero (0) to disable timeouts.
<b>Pre Switch (Reverse)</b>	Sets the reverse pre-run volume (that is, the volume before switch 1). The default is <b>0</b> . <b>Note:</b> Set this field to zero (0) to disable timeouts.
<b>Cal Temperature</b>	Sets the reference temperature value for calculations (typically 15°C in Europe). The default is <b>15</b> .
<b>Cal Pressure</b>	Sets the reference pressure value for calculations (typically 0 barg in Europe). The default is <b>0</b> .
<b>CTL Temperature</b>	Sets the reference temperature for the correction of the temperature of the liquid factor. The default is <b>15</b> .
<b>Density Units</b>	Indicates the density units Config600 uses for the density correction calculations. Click ▼ to display all valid values.
<b>DEG.API</b>	Use degrees API.
<b>KG/M3</b>	Use kilograms per cubic meter. This is the <b>default</b> .
<b>S.G.</b>	Use specific gravity.
<b>CH. 11 2004/7 CUST</b>	Use API MPMS Chapter 11.1 2004, Addendum 1, 2007 Imperial Units.
<b>CH. 11 2004/7 METRIC</b>	Use API MPMS Chapter 11.1 2004, Addendum 1, 2007 Metric Units.
<b>NORSOK I-105</b>	Use Norsok I-105 Appendix D density corrections.
<b>Product Type</b>	Indicates the type of petroleum product involved in the calculation. Click ▼ to display all valid values.
<b>TABLE LOOKUP</b>	S600+ reads values from a file in the Config600 3.0/Config/Project Name/extras directory and transfers that data into the S600+ with the configuration file. The default files hold values for the ASTM-IP Petroleum Measurement Tables 1952 Tables 5 and 6.

Field	Description
<b>A CRUDE</b>	<p>If Density Table Units = KG/M3 and reference temperature = 15 Deg C, Petroleum Measurement Tables 1980 Tables 53A and 54A.</p> <p>If Density Table Units = KG/M3 and reference temperature = 20 Deg C, Petroleum Measurement Tables 1988 Tables 59A and 60A.</p> <p>If Density Table Units = SG, Petroleum Measurement Tables 1980 Tables 23A and 24A.</p> <p>If Density Table Units = DEG API, Petroleum Measurement Tables 1980 Tables 5A and 6A.</p> <p>If Density Table Units = CH.11 2004/7, Cust API MPMS Chapter 11 2004.</p> <p>If Density Table Units = CH.11 2004/7, Metric API MPMS Chapter 11 2004.</p> <p>This is the <b>default</b>.</p>
<b>B REFINED</b>	<p>If Density Table Units = KG/M3 and reference temperature = 15 Deg C, Petroleum Measurement Tables 1980 Tables 53B and 54B.</p> <p>If Density Table Units = KG/M3 and reference temperature = 20 Deg C, Petroleum Measurement Tables 1988 Tables 59B and 60B.</p> <p>If Density Table Units = SG, Petroleum Measurement Tables 1980 Tables 23B and 24B.</p> <p>If Density Table Units = DEG API, Petroleum Measurement Tables 1980 Tables 5B and 6B.</p> <p>If Density Table Units = CH.11 2004/7, Cust API MPMS Chapter 11 2004.</p> <p>If Density Table Units = CH.11 2004/7, Metric API MPMS Chapter 11 2004.</p>

Field	Description
<b>C SPECIAL</b>	<p>If Density Table Units = KG/M3, Petroleum Measurement Tables 1980 Table 54C.</p> <p>If Density Table Units = SG, Petroleum Measurement Tables 1980 Tables 23C and 24C.</p> <p>If Density Table Units = DEG API, Petroleum Measurement Tables 1980 Tables 5C and 6C.</p> <p>If Density Table Units = CH.11 2004/7, Cust API MPMS Chapter 11 2004.</p> <p>If Density Table Units = CH.11 2004/7, Metric API MPMS Chapter 11 2004.</p> <p><b>Note:</b> Table 53C is not implemented as the assumption is made that the base density is already known. This is because Table 53C allows for a keypad entry of Alpha, and if this is known then the base density would be known.</p>
<b>D LUBE OILS</b>	<p>If Density Table Units = KG/M3 and reference temperature = 15 Deg C, Petroleum Measurement Tables 1982 Tables 53D and 54D.</p> <p>If Density Table Units = KG/M3 and reference temperature = 20 Deg C, Petroleum Measurement Tables 1988 Tables 59D and 60D.</p> <p>If Density Table Units = SG, Petroleum Measurement Tables 1982 Tables 23D and 24D.</p> <p>If Density Table Units = DEG API, Petroleum Measurement Tables 1982 Tables 5D and 6D.</p> <p>If Density Table Units = CH.11 2004/7, Cust API MPMS Chapter 11 2004.</p> <p>If Density Table Units = CH.11 2004/7, Metric API MPMS Chapter 11 2004.</p>
<b>LIGHT 1986</b>	<p>ASTM-IP-API Petroleum Measurement Tables for Light Hydrocarbon Liquids 1986 Tables 53 and 54.</p>
<b>ASTM IP 1952</b>	<p>ASTM-IP Petroleum Measurement Tables 1952 Tables 23, 24, 53 and 54.</p>

Field	Description
<b>USER K0K1</b>	If Density Table = KG/M3, Petroleum Measurement Tables 1980 Tables 53A and 54A with user entered values for K0 and K1. If Density Table = SG, Petroleum Measurement Tables 1980 Tables 23A and 24A with user entered values for K0 and K1. If Density Table = DEG API, Petroleum Measurement Tables 1980 Tables 5A and 6A with user entered values for K0 and K1.
<b>LIGHT TP25</b>	GPA TP-25 1998 (API Tables 23E and 24E).
<b>AROMATICS D1555-95</b>	ASTM D1555-95 Table Lookup.
<b>LIGHT TP27</b>	GPA TP-27 2007 (API Tables 23E, 24E, 53E, 54E, 59E and 60E).
<b>AROMATICS D1555M-00</b>	ASTM D1555M-00 Table Lookup.
<b>AROMATICS D1555-04A</b>	ASTM D1555-04a Calculation.
<b>AROMATICS D1555-08</b>	ASTM D1555M-08 Calculation.
<b>STO5.9 08 B1 UGC</b>	Gazprom STO-5.9 2008 Addendum B.1 Unstable Gas Condensate.
<b>STO5.9 08 B2 SLH</b>	Gazprom STO-5.9 2008 Addendum B.2 Stable Liquid Hydrocarbon.
<b>STO5.9 08 B3 WFLH</b>	Gazprom STO-5.9 2008 Addendum B.3 Wide Fraction Liquid Hydrocarbon.
<b>CPL Calculation</b>	Indicates the specific CPL calculation the S600+ uses to calculate the liquid pressure correction factor. Click ▼ to display all valid values. <b>Note:</b> This field does <b>not</b> display if you select Density Table Units CH.11 2004 CUST or CH.11 2004 METRIC or a Gazprom Product Type because these standards also specify the CPL calculation.
<b>OFF</b>	No CPL calculation. CPL value is set to 1.0.
<b>API1121</b>	API MPMS Ch. 11.2.1 1984.
<b>API1121M</b>	API MPMS Ch. 11.2.1M 1984. The default is API1121M.
<b>API1122</b>	API MPMS Ch. 11.2.2 1986.
<b>API1122M</b>	API MPMS Ch. 11.2.2M 1986. This is the <b>default</b> .
<b>CONSTANT</b>	Use a value you enter.
<b>DOWNER</b>	Paper entitled Generation of New Compressibility Tables for International Use presented by L. Downer 1979.
<b>Rounding</b>	Enables or disables calculation rounding. Click ▼ to display valid values.
<b>OFF</b>	Rounding is disabled. The default is <b>OFF</b> .

Field	Description
	<b>NATIVE</b> Rounding to the rules specified in the selected calculation standard.
	<b>API Ch. 12.2 Part 2</b> Rounding to API MPMS Ch.12.2 Part 2 – Measurement Tickets 1995.
	<b>API Ch. 12.2 Part 3</b> Rounding to API MPMS Ch.12.2 Part 3 – Proving Reports 1998.
	<b>Flocheck</b> Rounding to Emerson Flocheck verification software package.
	<b>ASTM D1250-04 Ch. 11</b> API MPMS Ch. 11.1 2004 (ASTM D1250-04) method to round to the Petroleum Measurement Tables 1980 Tables.
<b>Pipe Diam</b>	Sets the internal pipe diameter of the prover loop. The default is <b>500</b> .
<b>Elasticity</b>	Sets the value for Young's modulus of elasticity (expansion coefficient of tube steel), typically 2100000. The default is <b>10000</b> .
<b>Wall Thick</b>	Sets the wall thickness of the prover loop. The default is <b>5</b> .
<b>Tube Coeff</b>	Sets the tube temperature expansion coefficient, typically 0.000033. The default is <b>0.01</b> .
<b>Density Factor</b>	Used in conjunction with METER (DF) to correct meter density to prover density. The default is <b>1</b> .
<b>Location</b>	Used by volume v mass proving to select the location of the prover density used to convert prover volume to mass. Click ▼ to display valid values.
	<b>AT PROVER</b> Read density at the prover. This is the <b>default</b> value.
	<b>METER (C2)</b> Use Meter Density * CTLp * CPLp / (CTLm * CPLm), defined for proving a Micro Motion Coriolis meter.
	<b>METER (DF)</b> Use Meter Density * Density Factor
	<b>KNOWN PRODUCT</b> Enter a value.
<b>Meter Factor Deviation 1 Limit</b>	Sets the maximum allowed deviation from the initial base meter factor. The <b>default</b> value is <b>0.25%</b> . The system uses this value while performing the proved meter factor deviation checks. Refer to <i>Appendix B, Proving</i> for further information.
	<b>Note:</b> This stage is performed <b>only</b> if you configure the meter normal flow to a value greater than zero ( <b>Aramco-style linearisation</b> ).
<b>Meter Factor Deviation 2 Limit</b>	Sets the maximum allowed deviation from the initial base meter factor. The <b>default</b> value is <b>0.1%</b> . The system uses this value while performing the proved meter factor deviation checks. Refer to <i>Appendix B, Proving</i> for further information.
	<b>Note:</b> This stage is performed <b>only</b> if you configure the meter normal flow to a value greater than zero ( <b>Aramco-style linearisation</b> ).

Field	Description
<b>Meter Factor Reject Timeout</b>	<p>Following a successful prove, this value specifies the time period before the current prove results are automatically accepted and totals are adjusted based on the current prove results. During this time period, the current prove results can be manually <b>ACCEPTED</b> (totals will be adjusted) or <b>ACCEPTED NO ADJUST</b> (no totals adjustment). The <b>default</b> is <b>40</b> seconds. Refer to <i>Appendix B, Proving</i> for further information.</p> <p><b>Note:</b> This stage is performed <b>only</b> if you configure the meter normal flow to a value greater than zero (<b>Aramco-style linearisation</b>).</p>

3. Click in the hierarchy menu when you finish defining settings. A confirmation dialog box displays.
4. Click **Yes** to apply your changes. The PCSetup screen displays.

**Hardware** Hardware settings relate to the Prover (P154) module. You use these settings to define how the S600+ processes the raw pulse inputs to the prover. Typically, when the pulse count is low (less than 10,000 pulses per round trip), the S600+ uses either “Phase Locked Loop” or “Dual Chronometry” processing. This effectively divides each pulse into smaller parts to maintain accuracy.

1. Select **Hardware** from the hierarchy menu. The Hardware screen displays.

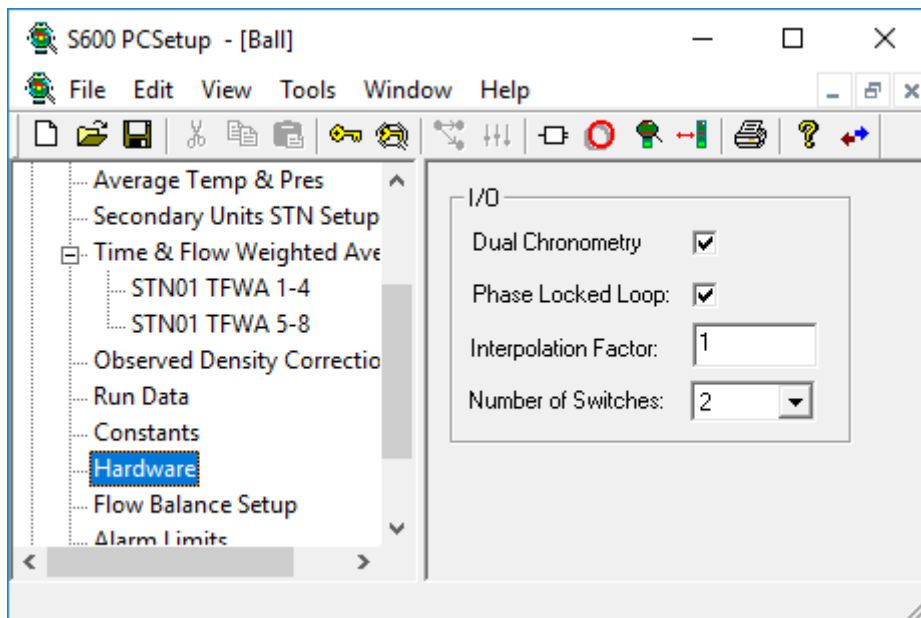

Figure 5-17. Hardware screen (Ball Prover)



## 2. Complete the following fields.

Field	Description
<b>Dual Chronometry</b>	Enables dual chronometry. Dual chronometry determines meter pulses by counting a series of whole meter pulses and then multiplying that value by the ratio of the time between the detector switches and the time required to accumulate the pulses. The default is unchecked ( <b>disabled</b> ).
<b>Phase Locked Loop</b>	Enables the phase locked loop. A phased locked loop multiplies the number of actual turbine pulses by a value (the Interpolation Factor) for greater accuracy. The default is unchecked ( <b>disabled</b> ). <b>Note:</b> <ul style="list-style-type: none"> <li>If you select this check box, you must <b>also</b> provide an Interpolation Factor value.</li> <li>If you select this check box, and are not using a physical PIM module, the raw pulses need to be wired into the PIMLOOP input on the P154 prover board (inputs 8 and 20). Dual Chronometry and PLL can be used independently or together.</li> </ul>
<b>Interpolation Factor</b>	Sets the interpolation factor value for the phase locked loops option, typically associated with the Pulse Interpolation Module (PIM). The default is <b>1</b> . If using a physical PIM module, the scaling factors should be set to 1 as the multiplication of the pulses is done in the PIM. <b>Note:</b> <ul style="list-style-type: none"> <li>This field displays <b>only</b> if you select the Phase Locked Loop option.</li> <li>If no physical PIM is used, the interpolation factor should be set between 0 and 1 where 1 indicates no interpolation (this value is used as a divider). For example, a value of 0.1 will cause the actual pulse count to be divided by 0.1 (in effect multiplying the value by 10).</li> </ul>
<b>Number of Switches</b>	Indicates the number of switches in the prover. Click ▼ to display valid values. Valid values are 1, 2, and 4; the default is <b>2</b> . <b>Note:</b> The base volume you use is determined by the number of switches you select. <ul style="list-style-type: none"> <li>If you select 1, use Base Volume 1.</li> <li>If you select 2, use Base Volume 1.</li> <li>If you select 4, the base volume will determine which switches to use.</li> </ul> For more information, refer to <i>Appendix B. 1.4.1, Number of Switches and Base Volume</i> .

3. Click in the hierarchy menu when you finish defining settings. A confirmation dialog box displays.

4. Click **Yes** to apply your changes. The PCSetup screen displays.

**Alarm Limits** The Alarm Limits screen sets the prover alarms. For a description of the alarms, refer to *Alarm Descriptions* in *Chapter 7, Advanced Setup Configuration*.

1. Select **Alarm Limits** from the hierarchy menu. The Alarm Limits screen displays.

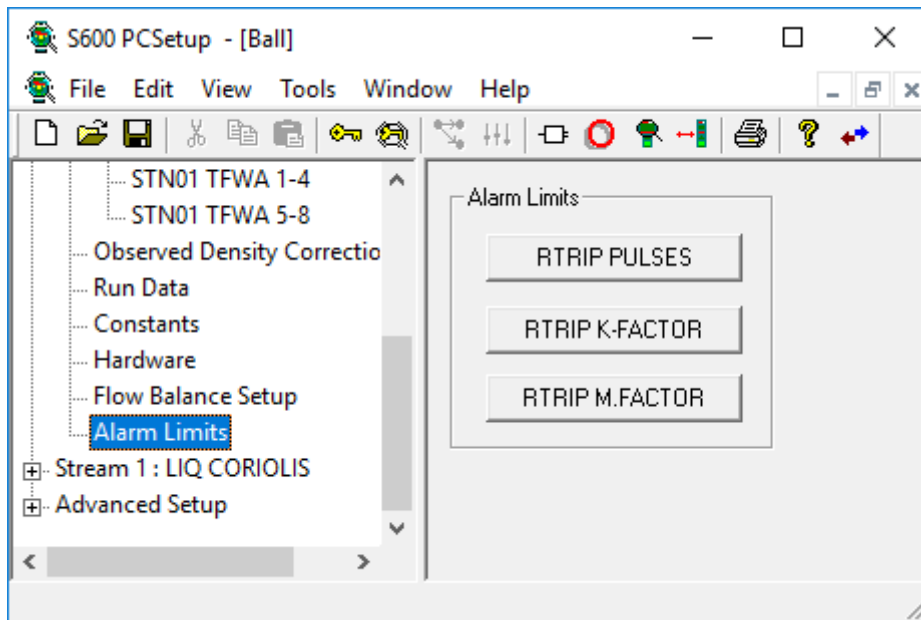

Figure 5-18. Alarm Limits screen (Ball Prover)

2. Click any of the following buttons to set alarm limits.

Button	Description
<b>RTRIP PULSES</b>	Click to display a Calculation Result dialog box you use to define the specific alarm limits for round trip (RTRIP) pulses. <b>Note:</b> In a bi-directional (BIDI) prover, this value reflects the sum of forward and reverse pulses.
<b>RTRIP K-FACTOR</b>	Click to display a Calculation Result dialog box you use to define the specific alarm limits for round trip K-factors. <b>Note:</b> In a uni-directional prover, this value reflects the forward pulses.
<b>RTRIP M.FACTOR</b>	Click to display a Calculation Result dialog box you use to define the specific alarm limits for round trip Meter Factors. <b>Note:</b> In a uni-directional prover, this value reflects the forward pulses.

3. Click in the hierarchy menu when you finish defining settings. A confirmation dialog box displays.
4. Click **Yes** to apply your changes. The PCSetup screen displays.

### 5.7.3 Prover – Compact (Liquid Only)

Two components enable you to control the prove:

- **Prove sequence** – Station-based function which sets up the prove environment.
- **Run control** – Prover-based function that drives the prover hardware, counts pulses, and performs the K-factor calculations.

Following a successful prove, the system verifies the stream normal flow rate value:

- If the normal flow rate is set to a value greater than zero (**Aramco-style linearisation**), the run control waits for a predefined amount of time for you to reject the current prove results. If a prove is rejected, the proving report is annotated as "ABORTED". If the time-out elapses, the prove sequence downloads the prove results to the stream being proved and the data is automatically used in the subsequent calculations.
- If the normal flow rate is zero (**non-Aramco-style linearisation**), the prove sequence downloads the prove results to the stream being proved but does not use the data until it is accepted either locally at the S600+ or via a supervisory computer.

When the prove runs complete, you can either re-run the prove or terminate, at which point (if so configured) the sequence restores the valves to their pre-prove state.

The compact prover has a small volume chamber so a proof run consists of repeated proof passes (a default of 5, a maximum of 39). The S600+ does not create a proof report, although you can add this option through a user stage. Contact Technical Support.

---

**Notes:**

- The prove sequence downloads both a K-factor and a meter factor. Applications typically use the original K-factor from the meter calibration report and update the meter factor, which may be either a fixed value or derived from a linearisation process. Alternatively, the meter factor can remain unchanged and the K-factor (fixed or linearised) updated.
- The meter factor deviation tests and the historical meter factor database are only supported for "local" streams (part of the same configuration with the prover), if you configure the stream normal flow rate to a value greater than zero.
- You define a ticket as Official or Unofficial when you configure a prove. This selection applies to both the Aramco-style and non-Aramco-style linearisation.

Following an **Official** prove, the prove sequence is determined by the Aramco / non-Aramco style linearisation selection.

Following the **Unofficial** prove, the prove sequence does not download the prove results to the stream being proved. This is typically used to determine an approximate K-Factor / Meter Factor before an official prove takes place or when maintenance activities are being performed on the site.

The Official/Unofficial selection displays in the report header.

---

**Run Data** Run Data settings allow you to define the prover stability check variables, the number of prove runs from which the system can calculate a K-factor/meter factor, and the tolerances allowed on a K-factor/meter factor. Once the S600+ completes a prove and calculates

these values, you can select a new K-factor or meter factor to replace the current K-factor or meter factor.

To edit the prover run data settings:

1. Select **Run Data** from the hierarchy menu. The Run Data screen displays.

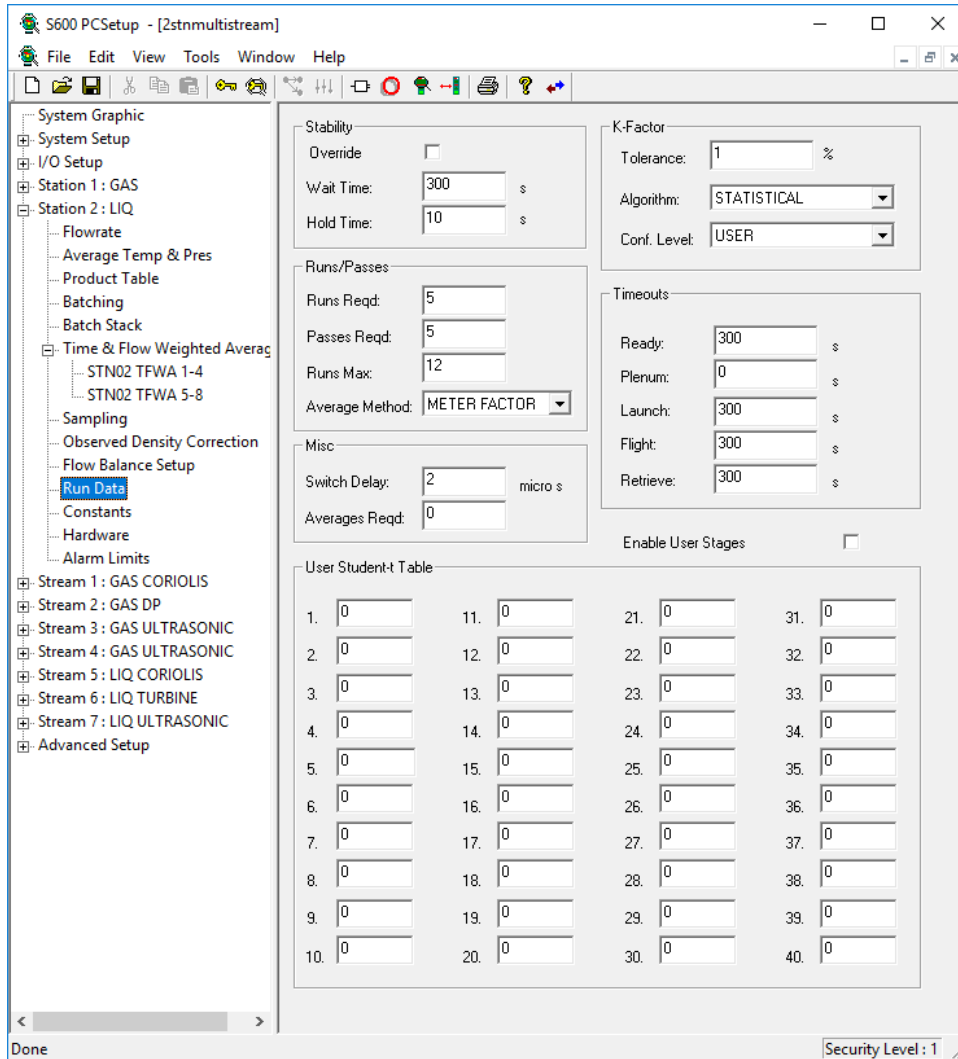

Figure 5-19. Run Data screen (Compact Prover)

2. Complete the following fields.

Field	Description
<b>Override</b>	Disables temperature and pressure stability checking. The default is unchecked (stability checking is <b>enabled</b> ). <b>Note:</b> If you <b>do not</b> select this option, you <b>must</b> complete the Wait Time and Hold Time fields.
<b>Wait Time</b>	Sets, in seconds, how long the S600+ waits for stability before moving to the hold stability prover stage. The default is <b>300</b> .
<b>Hold Time</b>	Sets, in seconds, how long the S600+ holds stability before starting prover runs. The default is <b>10</b> .
<b>Runs Reqd</b>	Sets the required number of consecutive runs which must be within the defined tolerance limits (typically, 5). The default is <b>5</b> . <b>Note:</b> It is possible that the number of required runs cannot be achieved before the maximum number of runs reached. In this situation, the user can either wait for the prove to abort (once the maximum number of runs has been reached) or perform a manual abort.
<b>Passes Reqd</b>	Sets the number of passes per prover run, to a maximum of 5. The default is <b>5</b> .
<b>Runs Max</b>	Sets the maximum number of runs to perform before aborting the sequence (up to 12 for the S600+). The default is <b>12</b> .
<b>Average Method</b>	Indicates the value to determine the repeatability and to indicate whether the final K-factor and meter factor are taken as the average of the run values, or are recalculated. Click ▼ to display valid values. <b>METER FACTOR</b> Use the run Meter Factors for repeatability and the average meter factor as the final value. This is the <b>default</b> . <b>K-FACTOR</b> Use the run K-factors for repeatability and the average K-factor as the final value. <b>PULSES</b> Use the run pulse counts for repeatability. This option also signifies to recalculate the final K-factor and Meter Factor using the average pulse count and other average values. API Ch.12 Section 2 part 3.
<b>Switch Delay</b>	Sets, in microseconds, the amount of time the S600+ waits before checking for switch 2. The default is <b>2</b> . <b>Note:</b> This parameter helps eliminate bounce on single-switch prover applications.
<b>Averages Reqd</b>	Sets the required number of pre-run average samples. The default is <b>0</b> .
<b>Tolerance</b>	Sets, as a percentage, the maximum deviation allowed before a run is unacceptable. The default is <b>1</b> .
<b>Algorithm</b>	Indicates the algorithm the system uses to calculate the K-factor tolerance. Click ▼ to display valid values. <b>API 1</b> API method: max deviation from (Average – Run) / Average. This is the <b>default</b> . <b>MX-MN/AVG</b> (Max – Min) / Average

Field	Description
<b>MX-MN/MX+MN2</b>	$(\text{Max} - \text{Min}) / ((\text{Max} + \text{Min}) / 2)$
<b>MX-MN/MN</b>	$(\text{Max} - \text{Min}) / \text{Min}$
<b>MX-MN/MX*MN</b>	$(\text{Max} - \text{Min}) / (\text{Max} * \text{Min})$
<b>MX-AV/AV</b>	$(\text{Max} - \text{Average}) / \text{Average}$
<b>AV-MN/AV</b>	$(\text{Average} - \text{Min}) / \text{Average}$
<b>STATISTICAL</b>	Calculates the statistical K-factor deviation using a Student-t table distribution.
<b>Conf. Level</b>	Sets the confidence level for a two-sided Student-t table used in statistical proving. Click ▼ to display valid values. For more information, see <i>Appendix B, Proving</i> . <b>Note:</b> This field displays only if you select <b>STATISTICAL</b> in the Algorithm field.
<b>Ready</b>	Sets, in seconds, the maximum time the S600+ waits for the ready signal. The default is <b>300</b> .
<b>Plenum</b>	Sets, in seconds, the maximum time the S600+ allows for plenum control. The default is <b>0</b> . <b>Note:</b> To <b>disable</b> plenum control, set this value to zero (0).
<b>Launch</b>	Sets, in seconds, the maximum time the S600+ waits for switch 1 after the launch command. The default is <b>300</b> .
<b>Flight</b>	Sets, in seconds, the maximum time the S600+ waits for switches 1 and 2 after the launch command. The default is <b>300</b> .
<b>Retrieve</b>	Sets, in seconds, the maximum time the S600+ waits for an upstream signal. The default is <b>300</b> .
<b>Enable User Stages</b>	Enables Logicalc user stages. The default is unchecked (user stages are <b>disabled</b> ).
<b>User Student-t Table</b>	Indicates the Student-t table values for degrees of freedom 1-40. For more information, see <i>Appendix B, Proving</i> . <b>Note:</b> These fields display <b>only</b> if you select <b>STATISTICAL</b> in the Algorithm field <b>and</b> <b>USER</b> in the Confidence Level field.

3. Click in the hierarchy menu when you finish defining settings. A confirmation dialog box displays.
4. Click **Yes** to apply your changes. The PCSetup screen displays.

**Constants** The Constants screen has two major areas. One area (consisting of the Stability R.O.C, Stability Bands, and Base Volume panes) defines stability checking parameters. The other area (consisting of the Reference, Setup, Plenum, and Misc panes) provides set-up information for the prover, including reference conditions and physical properties.

1. Select **Constants** from the hierarchy menu. The Constants screen displays.

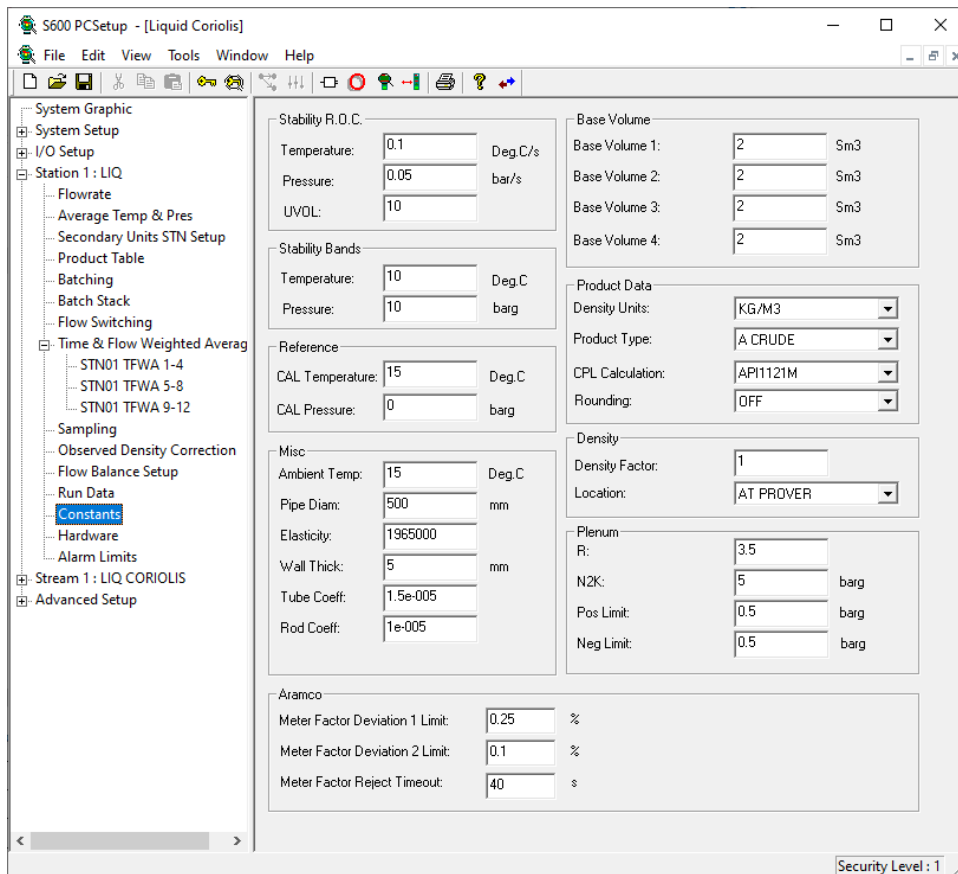

Figure 5-20. Constants screen (Compact Prover)

2. Complete the following fields.

Field	Description
<b>Temperature (Stability R.O.C.)</b>	Sets the Rate of Change (ROC) threshold limit for temperature, which the S600+ uses to check the ROC between the inlet, the outlet, and the meter. The default is <b>0.1</b> .
<b>Pressure (Stability R.O.C.)</b>	Sets the Rate of Change (ROC) threshold limit for pressure, which the S600+ uses to check the ROC between the inlet, the outlet, and the meter. The default is <b>0.05</b> .
<b>UVOL (Stability R.O.C.)</b>	Sets the Rate of Change (ROC) threshold limit for the stream uncorrected volume (UVOL) flowrate. The default is <b>10</b> .
<b>Temperature (Stability Bands)</b>	Sets the maximum temperature difference between the inlet, the outlet, and the meter. The default is <b>10</b> .
<b>Pressure (Stability Bands)</b>	Sets the maximum pressure difference between the inlet, the outlet, and the meter. The default is <b>10</b> .
<b>CAL Temperature</b>	Sets the prover calibration temperature used by the base volume correction calculation (CTSp). The default is <b>15</b> .
<b>CAL Pressure</b>	Sets the prover calibration pressure used by the base volume correction calculation (CPSp). The default is <b>15</b> .

<b>Field</b>	<b>Description</b>
<b>Ambient Temp</b>	Sets the ambient temperature used by the CTSp correction factor calculation. The default is <b>15</b> .
<b>Pipe Diam</b>	Sets the internal pipe diameter of the prover loop. The default is <b>500</b> .
<b>Elasticity</b>	Sets the value for Young's modulus of elasticity (expansion coefficient of tube steel), typically 2100000. The default is <b>10000</b> .
<b>Wall Thick</b>	Sets the wall thickness of the prover loop. The default is <b>5</b> .
<b>Tube Coeff</b>	Sets the tube temperature expansion coefficient. The default is <b>1.5e-005</b> .
<b>Rod Coeff</b>	Sets the coefficient of linear expansion for the invar rod. The default is <b>1e-005</b> .
<b>Base Volume 1, 2, 3, 4</b>	Sets the calibrated cylinder volume between detector switch activation (base volume). The default is <b>1</b> .
<b>Density Units</b>	Indicates the density units the S600+ uses for the density correction calculations. Click ▼ to display valid values.
	<b>DEG.API</b> Use degrees API.
	<b>KG/M3</b> Use kilograms per cubic meter. The default is <b>KG/M3</b> .
	<b>S.G.</b> Use specific gravity.
	<b>CH. 11 2004/7 CUST</b> Use API MPMS Chapter 11.1 2004, Addendum 1, 2007 Imperial Units.
	<b>CH. 11 2004/7 METRIC</b> Use API MPMS Chapter 11.1 2004, Addendum 1, 2007 Metric Units.
	<b>NORSOK I-105</b> Use Norsok I-105 Appendix D density corrections.
<b>Product Type</b>	Indicates the type of petroleum product involved in the calculation. Click ▼ to display valid values. The default is <b>A CRUDE</b> .
	<b>TABLE LOOKUP</b> S600+ reads values from a file in the Config600 3.0/Config/Project Name/extras directory and transfers that data into the S600+ with the configuration file. The default files hold values for the ASTM-IP Petroleum Measurement Tables 1952 Tables 5 and 6.



Field	Description
<b>A CRUDE</b>	<p>If Density Table Units = KG/M3 and reference temperature = 15 Deg C, Petroleum Measurement Tables 1980 Tables 53A and 54A.</p> <p>If Density Table Units = KG/M3 and reference temperature = 20 Deg C, Petroleum Measurement Tables 1988 Tables 59A and 60A.</p> <p>If Density Table Units = SG, Petroleum Measurement Tables 1980 Tables 23A and 24A.</p> <p>If Density Table Units = DEG API, Petroleum Measurement Tables 1980 Tables 5A and 6A.</p> <p>If Density Table Units = CH.11 2004/7, Cust API MPMS Chapter 11 2004.</p> <p>If Density Table Units = CH.11 2004/7, Metric API MPMS Chapter 11 2004.</p>
<b>B REFINED</b>	<p>If Density Table Units = KG/M3 and reference temperature = 15 Deg C, Petroleum Measurement Tables 1980 Tables 53B and 54B.</p> <p>If Density Table Units = KG/M3 and reference temperature = 20 Deg C, Petroleum Measurement Tables 1988 Tables 59B and 60B.</p> <p>If Density Table Units = SG, Petroleum Measurement Tables 1980 Tables 23B and 24B.</p> <p>If Density Table Units = DEG API, Petroleum Measurement Tables 1980 Tables 5B and 6B.</p> <p>If Density Table Units = CH.11 2004/7, Cust API MPMS Chapter 11 2004.</p> <p>If Density Table Units = CH.11 2004/7, Metric API MPMS Chapter 11 2004.</p>

Field	Description
<b>C SPECIAL</b>	<p>If Density Table Units = KG/M3, Petroleum Measurement Tables 1980 Table 54C.</p> <p>If Density Table Units = SG, Petroleum Measurement Tables 1980 Tables 23C and 24C.</p> <p>If Density Table Units = DEG API, Petroleum Measurement Tables 1980 Tables 5C and 6C.</p> <p>If Density Table Units = CH.11 2004/7, Cust API MPMS Chapter 11 2004.</p> <p>If Density Table Units = CH.11 2004/7, Metric API MPMS Chapter 11 2004.</p> <p><b>Note:</b> Table 53C is not implemented as the assumption is made that the base density is already known. This is because Table 53C allows for a keypad entry of Alpha, and if this is known then the base density would be known.</p>
<b>D LUBE OILS</b>	<p>If Density Table Units = KG/M3 and reference temperature = 15 Deg C, Petroleum Measurement Tables 1982 Tables 53D and 54D.</p> <p>If Density Table Units = KG/M3 and reference temperature = 20 Deg C, Petroleum Measurement Tables 1988 Tables 59D and 60D.</p> <p>If Density Table Units = SG, Petroleum Measurement Tables 1982 Tables 23D and 24D.</p> <p>If Density Table Units = DEG API, Petroleum Measurement Tables 1982 Tables 5D and 6D.</p> <p>If Density Table Units = CH.11 2004/7, Cust API MPMS Chapter 11 2004.</p> <p>If Density Table Units = CH.11 2004/7, Metric API MPMS Chapter 11 2004.</p>
<b>LIGHT 1986</b>	<p>ASTM-IP-API Petroleum Measurement Tables for Light Hydrocarbon Liquids 1986 Tables 53 and 54.</p>
<b>ASTM IP 1952</b>	<p>ASTM-IP Petroleum Measurement Tables 1952 Tables 23, 24, 53 and 54.</p>

Field	Description
<b>USER K0K1</b>	If Density Table = KG/M3, Petroleum Measurement Tables 1980 Tables 53A and 54A with user entered values for K0 and K1. If Density Table = SG, Petroleum Measurement Tables 1980 Tables 23A and 24A with user entered values for K0 and K1. If Density Table = DEG API, Petroleum Measurement Tables 1980 Tables 5A and 6A with user entered values for K0 and K1.
<b>LIGHT TP25</b>	GPA TP-25 1998 (API Tables 23E and 24E).
<b>AROMATICS D1555-95</b>	ASTM D1555-95 Table Lookup.
<b>LIGHT TP27</b>	GPA TP-27 2007 (API Tables 23E, 24E, 53E, 54E, 59E and 60E).
<b>AROMATICS D1555M-00</b>	ASTM D1555M-00 Table Lookup.
<b>AROMATICS D1555-04A</b>	ASTM D1555-04a Calculation.
<b>AROMATICS D1555-08</b>	ASTM D1555M-08 Calculation.
<b>STO5.9 08 B1 UGC</b>	Gazprom STO-5.9 2008 Addendum B.1 Unstable Gas Condensate.
<b>STO5.9 08 B2 SLH</b>	Gazprom STO-5.9 2008 Addendum B.2 Stable Liquid Hydrocarbon.
<b>STO5.9 08 B3 WFLH</b>	Gazprom STO-5.9 2008 Addendum B.3 Wide Fraction Liquid Hydrocarbon.
<b>CPL Calculation</b>	Indicates the specific correction for the pressure of the liquid (CPL) value the S600+ Uses. Click ▼ to display valid values. The default is <b>API1121M</b> .
<b>OFF</b>	No CPL calculation. CPL value is set to 1.0.
<b>API1121</b>	API MPMS Ch. 11.2.1 1984.
<b>API1121M</b>	API MPMS Ch. 11.2.1M 1984.
<b>API1122</b>	API MPMS Ch. 11.2.2 1986.
<b>API1122M</b>	API MPMS Ch. 11.2.2M 1986.
<b>CONSTANT</b>	Use a value you enter.
<b>DOWNER</b>	Paper entitled Generation of New Compressibility Tables for International Use presented by L. Downer 1979.
<b>Rounding</b>	Enables or disables calculation rounding. Click ▼ to display valid values. The default is <b>OFF</b> .
<b>OFF</b>	Rounding is disabled.
<b>NATIVE</b>	Rounding to the rules specified in the selected calculation standard.
<b>API Ch.12.2 Part 2</b>	Rounding to API MPMS Ch.12.2 Part 2 – Measurement Tickets 1995.
<b>API Ch.12.2 Part 3</b>	Rounding to API MPMS Ch.12.2 Part 3 – Proving Reports 1998.
<b>Flocheck</b>	Rounding to Emerson Flocheck verification software package.

Field	Description
	<b>ASTM D1250-04 Ch. 11</b> API MPMS Ch. 11.1 2004 (ASTM D1250-04) method to round to the Petroleum Measurement Tables 1980 Table.
<b>Density Factor</b>	Used in conjunction with METER (DF) to correct meter density to prover density. The default is <b>1</b> .
<b>Location</b>	Used by volume v mass proving to select the location of the prover density used to convert prover volume to mass. Click ▼ to display valid values. The default value is <b>AT PROVER</b> . <b>AT PROVER</b> Read density at the prover. <b>METER (C2)</b> Use Meter Density * CTLp * CPLp / (CTLm * CPLm), defined for proving a Micro Motion Coriolis meter. <b>METER (DF)</b> Use Meter Density * Density Factor <b>KNOWN PRODUCT</b> Enter a value.
<b>R</b>	Sets the R constant value used in the plenum control algorithm. The default is <b>3.5</b> .
<b>N2K</b>	Sets the N2K constant value used in the plenum control algorithm. The default is <b>5</b> .
<b>Pos Limit</b>	Sets the positive plenum pressure tolerance. The default is <b>0.5</b> .
<b>Neg Limit</b>	Sets the negative plenum pressure tolerance. The default is <b>0.5</b> .
<b>Meter Factor Deviation 1 Limit</b>	Sets the maximum allowed deviation from the initial base meter factor. The <b>default</b> value is <b>0.25%</b> . The system uses this value while performing the proved meter factor deviation checks. Refer to <i>Appendix B, Proving</i> for further information. <b>Note:</b> This stage is performed <b>only</b> if you configure the meter normal flow to a value greater than zero ( <b>Aramco-style linearisation</b> ).
<b>Meter Factor Deviation 2 Limit</b>	Sets the maximum allowed deviation from the initial base meter factor. The <b>default</b> value is <b>0.1%</b> . The system uses this value while performing the proved meter factor deviation checks. Refer to <i>Appendix B, Proving</i> for further information. <b>Note:</b> This stage is performed <b>only</b> if you configure the meter normal flow to a value greater than zero ( <b>Aramco-style linearisation</b> ).
<b>Meter Factor Reject Timeout</b>	Following a successful prove, this value specifies the time period before the current prove results are automatically accepted and totals are adjusted based on the current prove results. During this time period, the current prove results can be manually <b>ACCEPTED</b> (totals will be adjusted) or <b>ACCEPTED NO ADJUST</b> (no totals adjustment). The <b>default</b> is <b>40</b> seconds. Refer to <i>Appendix B, Proving</i> for further information. <b>Note:</b> This stage is performed <b>only</b> if you configure the meter normal flow to a value greater than zero ( <b>Aramco-style linearisation</b> ).

3. Click in the hierarchy menu when you finish defining settings. A confirmation dialog box displays.
4. Click **Yes** to apply your changes. The PCSetup screen displays.

**Hardware** Hardware settings relate to the Prover (P154) module. You use these settings to define how the S600+ processes the raw pulse inputs to the prover. Typically, when the pulse count is low (less than 10,000 pulses per round trip), the S600+ uses either “Phase Locked Loop” or “Dual Chronometry” processing. This effectively divides each pulse into smaller parts to ensure accuracy is maintained.

1. Select **Hardware** from the hierarchy menu. The Hardware screen displays.

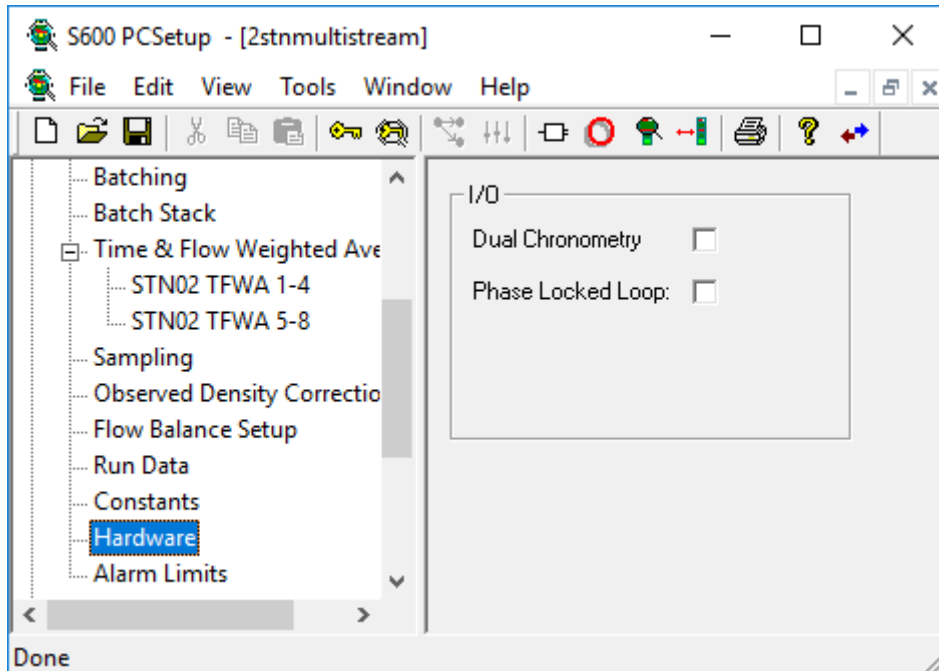

Figure 5-21. Hardware screen (Compact Prover)

2. Complete the following fields.

Field	Description
<b>Dual Chronometry</b>	Enables dual chronometry. Dual chronometry determines meter pulses by counting a series of whole meter pulses and then multiplying that value by the ratio of the time between the detector switches and the time required to accumulate the pulses. The default is unchecked ( <b>disabled</b> ).
<b>Phase Locked Loop</b>	Enables phase locked loops. A phased locked loop multiplies the number of actual turbine pulses by a value (the Interpolation Factor) for greater accuracy. The default is unchecked ( <b>disabled</b> ). <b>Note:</b> <ul style="list-style-type: none"> <li>▪ If you select this check box, you must <b>also</b> provide an Interpolation Factor value.</li> <li>▪ If you select this check box and are not using a physical PIM module, the raw pulses need to be wired into the PIMLOOP input on the P154 prover board (inputs 8 and 20).</li> </ul> Dual Chronometry and PLL can be used independently or together.

Field	Description
<b>Interpolation Factor</b>	<p>Sets the interpolation factor value for the phase locked loops option, typically associated with the Pulse Interpolation Module (PIM). The default is 1.</p> <p>If using a physical PIM module, the scaling factors should be set to 1 as the multiplication of the pulses is done in the PIM.</p> <p><b>Note:</b></p> <ul style="list-style-type: none"> <li>This field displays <b>only</b> if you select the Phase Locked Loop option.</li> <li>If no physical PIM is used, the interpolation factor should be set between 0 and 1 where 1 indicates no interpolation (this value is used as a divider). For example, a value of 0.1 will cause the actual pulse count to be divided by 0.1 (in effect multiplying the value by 10).</li> </ul>

- Click in the hierarchy menu when you finish defining settings. A confirmation dialog box displays.
- Click **Yes** to apply your changes. The PCSetup screen displays.

**Alarm Limits**

The Alarm Limits screen sets the prover alarms. For a description of the alarms, refer to “Alarm Descriptions” in *Chapter 7, Advanced Setup Configuration*.

- Select **Alarm Limits** from the hierarchy menu. The Alarm Limits screen displays.

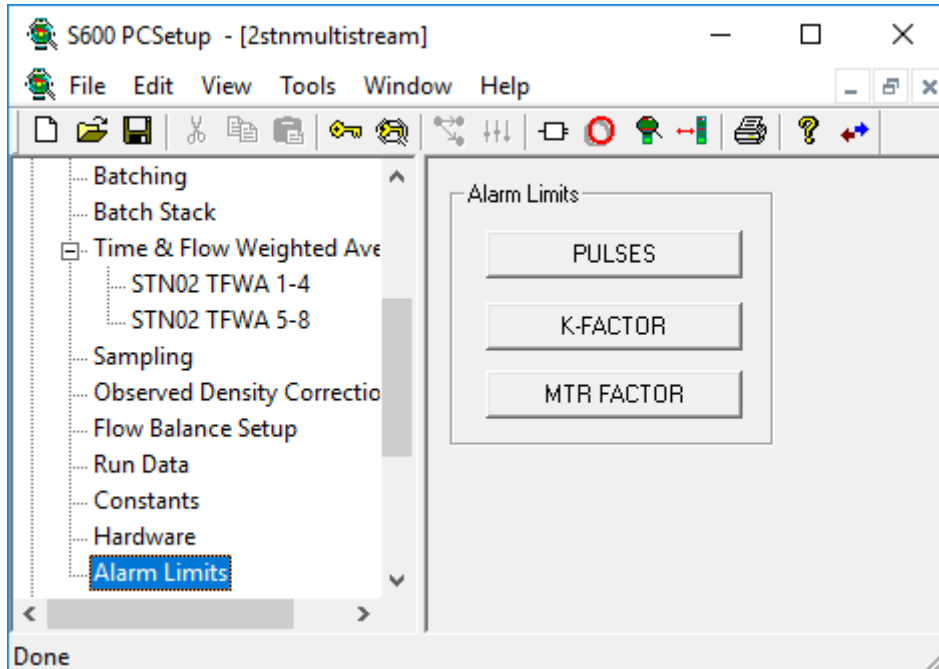

Figure 5-22. Alarm Limits screen (Compact Prover)

- Click any of the following buttons to set alarm limits:

Button	Description
<b>PULSES</b>	Click to display a Calculation Result dialog box you use to define the specific alarm limits for pulses. <b>Note:</b> This value reflects the cumulative pulses over a run, which consists of multiple passes. You set the number of passes in the Run Data screen.
<b>K FACTOR</b>	Click to display a Calculation Result dialog box you use to define the specific alarm limits for K-factors.
<b>MTR FACTOR</b>	Click to display a Calculation Result dialog box you use to define the specific alarm limits for Meter Factors.

- Click in the hierarchy menu when you finish defining alarm limits. A confirmation dialog box displays.
- Click **Yes** to apply your changes. The PCSetup screen displays.

#### 5.7.4 Prover – Master Meter (Gas and Liquid)

The primary function of the Master Meter is to provide an accurate “meter factor” value for the proving stream. The S600+ then uses this value to calibrate all other meters.

The proving stream receives pulses from its meter and generates a pulse train output, which represents the number of pulses received. The Master Meter counts these pulses during a proof run and also counts the pulses from its own meter (the master). When the proof run completes, the S600+ calculates a meter factor for the stream, based on the Master Meter’s meter factor and the ratio of the correct stream output pulse count to the Master Meter’s turbine pulse count.



**Caution**

**It is extremely unlikely that any one S600+ configuration would contain all the settings discussed in this section. For that reason, several sample configurations demonstrate the settings.**

Two components enable you to control the prove:

- **Prove sequence** – Station-based function which sets up the prove environment.
- **Run control** – Prover-based function that drives the prover hardware, counts pulses, and performs the K-factor calculations.

Following a successful prove, the system verifies the stream normal flow rate value:

- If the normal flow rate is set to a value greater than zero (**Aramco-style linearisation**), the run control waits for a predefined amount of time for you to reject the current prove results. If a prove is rejected, the proving report is annotated as "ABORTED". If the time-out elapses, the prove sequence downloads the prove results to the stream being proved and the data is automatically used in the subsequent calculations.

- If the normal flow rate is zero (**non-Aramco-style linearisation**), the prove sequence downloads the prove results to the stream being proved but does not use the data until it is accepted either locally at the S600+ or via a supervisory computer.

When the prove runs complete, you can either re-run the prove or terminate, at which point (if so configured) the sequence restores the valves to their pre-prove state.

---

**Notes:**

- Aramco-style linearisation is **only** applicable to Liquid Master Meter proving. Gas Master Meter proving always uses the non-Aramco style linearisation.
- The prove sequence downloads both a K-factor and a meter factor. Applications typically use the original K-factor from the meter calibration report and update the meter factor, which may be either a fixed value or derived from a linearisation process. Alternatively the meter factor can remain unchanged and the K-factor (fixed or linearised) updated.
- The meter factor deviation tests and the historical meter factor database are **only** applicable to Liquid Master Meter proving.
- The meter factor deviation tests and the historical meter factor database are **only** supported for "local" streams (part of the same configuration with the prover) if you configure the stream normal flow rate to a value greater than zero and have selected "Product Table with History" in PC Setup.
- You define a ticket as Official or Unofficial when you configure a prove. This selection applies to both the Aramco-style and non-Aramco-style linearisation.

Following an **Official** prove, the prove sequence is determined by the Aramco / non-Aramco style linearisation selection.

Following the **Unofficial** prove, the prove sequence does not download the prove results to the stream being proved. This is typically used to determine an approximate K-Factor / Meter Factor before an official prove takes place or when maintenance activities are being performed on the site.

The Official/Unofficial selection displays in the report header.

- For a list of supported Master Meter/Stream combinations, refer to *Appendix B.3.1 Master Meter/Stream Combinations*.
- 

**Run Data** Run Data settings allow you to define the prover stability check variables, the number of prove runs from which the system can calculate a K-factor/meter factor, and the tolerances allowed on a K-factor/meter factor. Once the S600+ completes a prove and calculates these values, you can select a new K-factor or meter factor to replace the current K-factor or meter factor.



To edit the prover run data settings:

1. Select **Run Data** from the hierarchy menu. The Run Data screen displays.

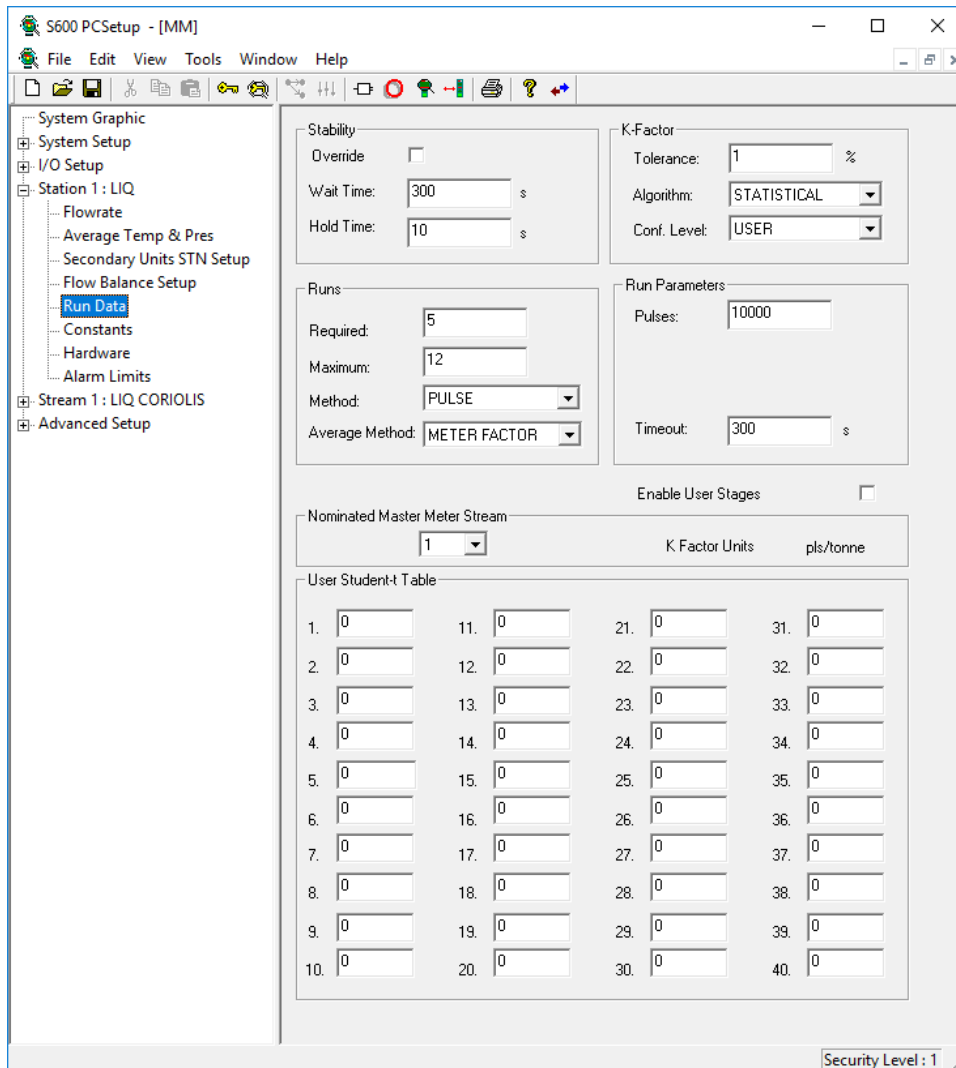

Figure 5-23. Run Data (MMeter Prover)

2. Complete the following fields.

Field	Description								
<b>Override</b>	Disables temperature and pressure stability checking. The default is unchecked (stability checking is <b>enabled</b> ). <b>Note:</b> If you <b>do not</b> select this option, you <b>must</b> complete the Wait Time and Hold Time fields.								
<b>Wait Time</b>	Sets, in seconds, how long the S600+ waits for stability before moving to the hold stability prover stage. The default is <b>60</b> .								
<b>Hold Time</b>	Sets, in seconds, how long the S600+ holds stability before starting prover runs. The default is <b>10</b> . <b>Note:</b> The S600+ aborts the prover run if stability is lost during the stability hold time.								
<b>Required</b>	Sets the required number of consecutive runs which must be within the defined tolerance limits (typically, 5). The default is <b>5</b> . <b>Note:</b> It is possible that the number of required runs cannot be achieved before the maximum number of runs reached. In this situation, the user can either wait for the prove to abort (once the maximum number of runs has been reached) or perform a manual abort.								
<b>Maximum</b>	Sets the maximum number of runs to perform before aborting the sequence (up to 12 for the S600+). The default is <b>12</b> .								
<b>Method</b>	Indicates the method used to define a run. Click ▼ to display valid values. <table border="1" style="width: 100%; border-collapse: collapse;"> <tbody> <tr> <td style="width: 15%;"><b>PULSE</b></td> <td>Run completes when the pulse count equals the value defined in the Pulses field. This is the <b>default</b>.</td> </tr> <tr> <td><b>VOLUME</b></td> <td>Run completes when the flowed volume equals the value defined in the Volume field.</td> </tr> <tr> <td><b>TIME</b></td> <td>Run completes when the time elapsed equals the value defined in the Timeout field.</td> </tr> <tr> <td><b>MASS</b></td> <td>Run completes when the flowed mass equals the value defined in the mass field.</td> </tr> </tbody> </table>	<b>PULSE</b>	Run completes when the pulse count equals the value defined in the Pulses field. This is the <b>default</b> .	<b>VOLUME</b>	Run completes when the flowed volume equals the value defined in the Volume field.	<b>TIME</b>	Run completes when the time elapsed equals the value defined in the Timeout field.	<b>MASS</b>	Run completes when the flowed mass equals the value defined in the mass field.
<b>PULSE</b>	Run completes when the pulse count equals the value defined in the Pulses field. This is the <b>default</b> .								
<b>VOLUME</b>	Run completes when the flowed volume equals the value defined in the Volume field.								
<b>TIME</b>	Run completes when the time elapsed equals the value defined in the Timeout field.								
<b>MASS</b>	Run completes when the flowed mass equals the value defined in the mass field.								
<b>Average Method</b>	Indicates the value to determine the repeatability and to indicate whether the final K-factor and meter factor are taken as the average of the run values, or are re-calculated. Click ▼ to display valid values. <table border="1" style="width: 100%; border-collapse: collapse;"> <tbody> <tr> <td style="width: 15%;"><b>METER FACTOR</b></td> <td>Use the run Meter Factors for repeatability and the average meter factor as the final value. This is the <b>default</b>.</td> </tr> <tr> <td><b>K-FACTOR</b></td> <td>Use the run K-factors for repeatability and the average K-factor as the final value.</td> </tr> <tr> <td><b>PULSES</b></td> <td>Use the run pulse counts for repeatability. This option also signifies to recalculate the final K-factor and meter factor using the average pulse count and other average values. API Ch.12 Section 2 part 3.</td> </tr> </tbody> </table>	<b>METER FACTOR</b>	Use the run Meter Factors for repeatability and the average meter factor as the final value. This is the <b>default</b> .	<b>K-FACTOR</b>	Use the run K-factors for repeatability and the average K-factor as the final value.	<b>PULSES</b>	Use the run pulse counts for repeatability. This option also signifies to recalculate the final K-factor and meter factor using the average pulse count and other average values. API Ch.12 Section 2 part 3.		
<b>METER FACTOR</b>	Use the run Meter Factors for repeatability and the average meter factor as the final value. This is the <b>default</b> .								
<b>K-FACTOR</b>	Use the run K-factors for repeatability and the average K-factor as the final value.								
<b>PULSES</b>	Use the run pulse counts for repeatability. This option also signifies to recalculate the final K-factor and meter factor using the average pulse count and other average values. API Ch.12 Section 2 part 3.								

Field	Description
<b>Tolerance</b>	Identifies, as a percentage, the maximum deviation allowed before a run is unacceptable. The default is <b>1</b> .
<b>Algorithm</b>	Indicates the algorithm the system uses to calculate the K factor tolerance. Click ▼ to display valid values.
<b>API 1</b>	API method: max deviation from (Average – Run) / Average. This is the <b>default</b> .
<b>MX-MN/AVG</b>	(Max – Min) / Average
<b>MX-MN/MX+MN2</b>	(Max – Min) / ((Max + Min) / 2)
<b>MX-MN/MN</b>	(Max – Min) / Min
<b>MX-MN/MX*MN</b>	(Max – Min) / (Max * Min)
<b>MX-AV/AV</b>	(Max – Average) / Average
<b>AV-MN/AV</b>	(Average – Min) / Average
<b>STATISTICAL</b>	Calculates the statistical K-factor deviation using a Student-t table distribution.
<b>Conf. Level</b>	Sets the confidence level for a two-sided Student-t table used in statistical proving. Click ▼ to display valid values. For more information, see <i>Appendix B, Proving</i> . <b>Note:</b> This field displays <b>only</b> if you select <b>STATISTICAL</b> in the Algorithm field.
<b>Pulses</b>	Defines the number of pulses required for one run. The default is <b>10000</b> . <b>Note:</b> This field displays <b>only</b> if you select <b>PULSE</b> as a Run Method.
<b>Volume</b>	Defines the required volume for one run. The default is <b>50</b> . <b>Note:</b> This field displays <b>only</b> if you select <b>VOLUME</b> as a Run Method.
<b>Timeout</b>	Sets, in seconds, the maximum time for any prover run. The default is <b>300</b> . <b>Note:</b> If you select <b>TIME</b> as a Run Method, this field indicates the maximum duration for a run.
<b>Nominated Master Meter Stream</b>	Sets the stream number to use as the master meter.
<b>Enable User Stages</b>	Enables Logicalc user stages. The default is unchecked (user stages are <b>disabled</b> ).
<b>User Student-t Table</b>	Indicates the Student-t table values for degrees of freedom 1-40. For more information, see <i>Appendix B, Proving</i> . <b>Note:</b> These fields display <b>only</b> if you select <b>STATISTICAL</b> in the Algorithm field <b>and</b> <b>USER</b> in the Confidence Level field.

3. Click in the hierarchy menu when you finish defining settings. A confirmation dialog box displays.
4. Click **Yes** to apply your changes. The PCSetup screen displays.

**Constants** The Constants screen is split into two areas. One area (consisting of the Stability R.O.C and Stability Bands panes) defines stability checking parameters. The other area (consisting of the Reference, Master Meter, and Setup panes) provides set-up information for the prover, including reference conditions and physical properties.

1. Select **Constants** from the hierarchy menu. The Constants screen displays.

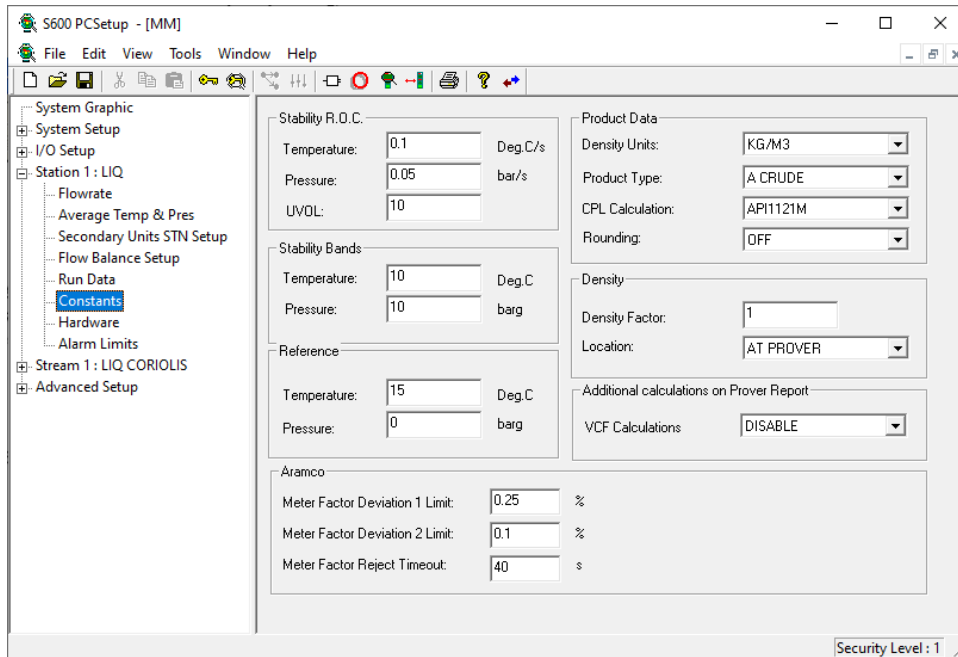

Figure 5-24. Constants screen (MMeter Prover)

2. Complete the following fields.

Field	Description
<b>Temperature (Stability R.O.C)</b>	Sets the Rate of Change (ROC) threshold limit for temperature, which the S600+ uses to check the ROC between the inlet, the outlet, and the meter. The default is <b>0.1</b> .
<b>Pressure (Stability R.O.C.)</b>	Sets the Rate of Change (ROC) threshold limit for pressure, which the S600+ uses to check the ROC between the inlet, the outlet, and the meter. The default is <b>0.05</b> .
<b>UVOL (Stability R.O.C.)</b>	Sets the Rate of Change (ROC) threshold limit for the stream uncorrected volume (UVOL) flowrate. The default is <b>10</b> .
<b>Temperature (Stability Bands)</b>	Sets the maximum temperature difference between the inlet, the outlet, and the meter. The default is <b>10</b> .
<b>Pressure (Stability Bands)</b>	Sets the maximum pressure difference between the inlet, the outlet, and the meter. The default is <b>10</b> .
<b>Temperature (Reference)</b>	Sets the reference temperature value for calculations (typically 15°C in Europe). The default is <b>15</b> .
<b>Pressure (Reference)</b>	Sets the reference pressure value for calculations (typically 0 barg in Europe). The default is <b>0</b> .

Field	Description												
<b>Base K Factor</b>	<p>Sets the base K-factor value for Master Meter calculations.</p> <p><b>Note:</b> This may be a <b>read-only</b> field in some applications.</p>												
<b>Density Units</b>	<p>Indicates the density units the S600+ uses for the density correction calculations. Click ▼ to display all valid values.</p> <p><b>Note:</b> This selection is applicable <b>only</b> to Liquid Master Meter proving.</p> <table border="1"> <tbody> <tr> <td><b>DEG.API</b></td> <td>Use degrees API.</td> </tr> <tr> <td><b>KG/M3</b></td> <td>Use kilograms per cubic meter. This is the <b>default</b>.</td> </tr> <tr> <td><b>S.G.</b></td> <td>Use specific gravity.</td> </tr> <tr> <td><b>CH. 11 2004/7 CUST</b></td> <td>Use API MPMS Chapter 11.1 2004, Addendum 1, 2007 Imperial Units.</td> </tr> <tr> <td><b>CH. 11 2004/7 METRIC</b></td> <td>Use API MPMS Chapter 11.1 2004, Addendum 1, 2007 Metric Units.</td> </tr> <tr> <td><b>NORSOK I-105</b></td> <td>Use Norsok I-105 Appendix D density corrections.</td> </tr> </tbody> </table>	<b>DEG.API</b>	Use degrees API.	<b>KG/M3</b>	Use kilograms per cubic meter. This is the <b>default</b> .	<b>S.G.</b>	Use specific gravity.	<b>CH. 11 2004/7 CUST</b>	Use API MPMS Chapter 11.1 2004, Addendum 1, 2007 Imperial Units.	<b>CH. 11 2004/7 METRIC</b>	Use API MPMS Chapter 11.1 2004, Addendum 1, 2007 Metric Units.	<b>NORSOK I-105</b>	Use Norsok I-105 Appendix D density corrections.
<b>DEG.API</b>	Use degrees API.												
<b>KG/M3</b>	Use kilograms per cubic meter. This is the <b>default</b> .												
<b>S.G.</b>	Use specific gravity.												
<b>CH. 11 2004/7 CUST</b>	Use API MPMS Chapter 11.1 2004, Addendum 1, 2007 Imperial Units.												
<b>CH. 11 2004/7 METRIC</b>	Use API MPMS Chapter 11.1 2004, Addendum 1, 2007 Metric Units.												
<b>NORSOK I-105</b>	Use Norsok I-105 Appendix D density corrections.												
<b>Product Type</b>	<p>Indicates the type of petroleum product involved in the calculation. Click ▼ to display all valid values. The default is <b>A CRUDE</b>.</p> <p><b>Note:</b> This selection is applicable <b>only</b> to Liquid Master Meter proving.</p> <table border="1"> <tbody> <tr> <td><b>TABLE LOOKUP</b></td> <td>S600+ reads values from a file in the Config600 3.0/Config/Project Name/extras directory and transfers that data into the S600+ with the configuration file. The default files hold values for the ASTM-IP Petroleum Measurement Tables 1952 Tables 5 and 6.</td> </tr> <tr> <td><b>A CRUDE</b></td> <td> <p>If Density Table Units = KG/M3 and reference temperature = 15 Deg C, Petroleum Measurement Tables 1980 Tables 53A and 54A.</p> <p>If Density Table Units = KG/M3 and reference temperature = 20 Deg C, Petroleum Measurement Tables 1988 Tables 59A and 60A.</p> <p>If Density Table Units = SG, Petroleum Measurement Tables 1980 Tables 23A and 24A.</p> <p>If Density Table Units = DEG API, Petroleum Measurement Tables 1980 Tables 5A and 6A.</p> <p>If Density Table Units = CH.11 2004/7, Cust API MPMS Chapter 11 2004.</p> <p>If Density Table Units = CH.11 2004/7, Metric API MPMS Chapter 11 2004.</p> </td> </tr> </tbody> </table>	<b>TABLE LOOKUP</b>	S600+ reads values from a file in the Config600 3.0/Config/Project Name/extras directory and transfers that data into the S600+ with the configuration file. The default files hold values for the ASTM-IP Petroleum Measurement Tables 1952 Tables 5 and 6.	<b>A CRUDE</b>	<p>If Density Table Units = KG/M3 and reference temperature = 15 Deg C, Petroleum Measurement Tables 1980 Tables 53A and 54A.</p> <p>If Density Table Units = KG/M3 and reference temperature = 20 Deg C, Petroleum Measurement Tables 1988 Tables 59A and 60A.</p> <p>If Density Table Units = SG, Petroleum Measurement Tables 1980 Tables 23A and 24A.</p> <p>If Density Table Units = DEG API, Petroleum Measurement Tables 1980 Tables 5A and 6A.</p> <p>If Density Table Units = CH.11 2004/7, Cust API MPMS Chapter 11 2004.</p> <p>If Density Table Units = CH.11 2004/7, Metric API MPMS Chapter 11 2004.</p>								
<b>TABLE LOOKUP</b>	S600+ reads values from a file in the Config600 3.0/Config/Project Name/extras directory and transfers that data into the S600+ with the configuration file. The default files hold values for the ASTM-IP Petroleum Measurement Tables 1952 Tables 5 and 6.												
<b>A CRUDE</b>	<p>If Density Table Units = KG/M3 and reference temperature = 15 Deg C, Petroleum Measurement Tables 1980 Tables 53A and 54A.</p> <p>If Density Table Units = KG/M3 and reference temperature = 20 Deg C, Petroleum Measurement Tables 1988 Tables 59A and 60A.</p> <p>If Density Table Units = SG, Petroleum Measurement Tables 1980 Tables 23A and 24A.</p> <p>If Density Table Units = DEG API, Petroleum Measurement Tables 1980 Tables 5A and 6A.</p> <p>If Density Table Units = CH.11 2004/7, Cust API MPMS Chapter 11 2004.</p> <p>If Density Table Units = CH.11 2004/7, Metric API MPMS Chapter 11 2004.</p>												

Field	Description
<b>B REFINED</b>	<p>If Density Table Units = KG/M3 and reference temperature = 15 Deg C, Petroleum Measurement Tables 1980 Tables 53B and 54B.</p> <p>If Density Table Units = KG/M3 and reference temperature = 20 Deg C, Petroleum Measurement Tables 1988 Tables 59B and 60B.</p> <p>If Density Table Units = SG, Petroleum Measurement Tables 1980 Tables 23B and 24B.</p> <p>If Density Table Units = DEG API, Petroleum Measurement Tables 1980 Tables 5B and 6B.</p> <p>If Density Table Units = CH.11 2004/7, Cust API MPMS Chapter 11 2004.</p> <p>If Density Table Units = CH.11 2004/7, Metric API MPMS Chapter 11 2004.</p>
<b>C SPECIAL</b>	<p>If Density Table Units = KG/M3, Petroleum Measurement Tables 1980 Table 54C.</p> <p>If Density Table Units = SG, Petroleum Measurement Tables 1980 Tables 23C and 24C.</p> <p>If Density Table Units = DEG API, Petroleum Measurement Tables 1980 Tables 5C and 6C.</p> <p>If Density Table Units = CH.11 2004/7, Cust API MPMS Chapter 11 2004.</p> <p>If Density Table Units = CH.11 2004/7, Metric API MPMS Chapter 11 2004.</p> <p><b>Note:</b> Table 53C is not implemented as the assumption is made that the base density is already known. This is because Table 53C allows for a keypad entry of Alpha, and if this is known then the base density would be known.</p>

<b>Field</b>	<b>Description</b>
<b>D LUBE OILS</b>	<p>If Density Table Units = KG/M3 and reference temperature = 15 Deg C, Petroleum Measurement Tables 1982 Tables 53D and 54D.</p> <p>If Density Table Units = KG/M3 and reference temperature = 20 Deg C, Petroleum Measurement Tables 1988 Tables 59D and 60D.</p> <p>If Density Table Units = SG, Petroleum Measurement Tables 1982 Tables 23D and 24D.</p> <p>If Density Table Units = DEG API, Petroleum Measurement Tables 1982 Tables 5D and 6D.</p> <p>If Density Table Units = CH.11 2004/7, Cust API MPMS Chapter 11 2004.</p> <p>If Density Table Units = CH.11 2004/7, Metric API MPMS Chapter 11 2004.</p>
<b>LIGHT 1986</b>	ASTM-IP-API Petroleum Measurement Tables for Light Hydrocarbon Liquids 1986 Tables 53 and 54.
<b>ASTM IP 1952</b>	ASTM-IP Petroleum Measurement Tables 1952 Tables 23, 24, 53 and 54.
<b>USER K0K1</b>	<p>If Density Table = KG/M3, Petroleum Measurement Tables 1980 Tables 53A and 54A with user entered values for K0 and K1.</p> <p>If Density Table = SG, Petroleum Measurement Tables 1980 Tables 23A and 24A with user entered values for K0 and K1.</p> <p>If Density Table = DEG API, Petroleum Measurement Tables 1980 Tables 5A and 6A with user entered values for K0 and K1.</p>
<b>LIGHT TP25</b>	GPA TP-25 1998 (API Tables 23E and 24E).
<b>AROMATICS D1555-95</b>	ASTM D1555-95 Table Lookup.
<b>LIGHT TP27</b>	GPA TP-27 2007 (API Tables 23E, 24E, 53E, 54E, 59E and 60E).
<b>AROMATICS D1555M-00</b>	ASTM D1555M-00 Table Lookup.
<b>AROMATICS D1555-04A</b>	ASTM D1555-04a Calculation.
<b>AROMATICS D1555-08</b>	ASTM D1555M-08 Calculation.
<b>STO5.9 08 B1 UGC</b>	Gazprom STO-5.9 2008 Addendum B.1 Unstable Gas Condensate.
<b>STO5.9 08 B2 SLH</b>	Gazprom STO-5.9 2008 Addendum B.2 Stable Liquid Hydrocarbon.

Field	Description
	<b>STO5.9 08 B3 WFLH</b> Gazprom STO-5.9 2008 Addendum B.3 Wide Fraction Liquid Hydrocarbon.
<b>CPL Calculation</b>	Indicates the specific CPL calculation the S600+ uses to calculate the liquid pressure correction factor. Click ▼ to display all valid values. <b>Note:</b> This selection is applicable <b>only</b> to Liquid Master Meter proving.
	<b>OFF</b> No CPL calculation. CPL value is set to 1.0.
	<b>API1121</b> API MPMS Ch. 11.2.1 1984.
	<b>API1121M</b> API MPMS Ch. 11.2.1M 1984. This is the <b>default</b> .
	<b>API1122</b> API MPMS Ch. 11.2.2 1986.
	<b>API1122M</b> API MPMS Ch. 11.2.2M 1986.
	<b>CONSTANT</b> Use a value you enter.
	<b>DOWNER</b> Paper entitled Generation of New Compressibility Tables for International Use presented by L. Downer 1979.
<b>Rounding</b>	Enables or disables calculation rounding. Click ▼ to display valid values.
	<b>OFF</b> Rounding is disabled. This is the <b>default</b> .
	<b>NATIVE</b> Rounding to the rules specified in the selected calculation standard.
	<b>API Ch.12.2 Part 2</b> Rounding to API MPMS Ch.12.2 Part 2 – Measurement Tickets 1995.
	<b>API Ch.12.2 Part 3</b> Rounding to API MPMS Ch.12.2 Part 3 – Proving Reports 1998.
	<b>Flocheck</b> Rounding to Emerson Flocheck verification software package.
	<b>ASTM D1250-04 Ch. 11</b> API MPMS Ch. 11.1 2004 (ASTM D1250-04) method to round to the Petroleum Measurement Tables 1980 Tables.
<b>Density Factor</b>	Used in conjunction with METER (DF) to correct meter density to prover density. The default is 1. <b>Note:</b> This selection is applicable <b>only</b> to Liquid Master Meter proving.
<b>Location</b>	Used by volume v mass proving to select the location of the prover density used to convert prover volume to mass. Click ▼ to display valid values. <b>Note:</b> This selection is applicable <b>only</b> to Liquid Master Meter proving.
	<b>AT PROVER</b> Read density at the prover. This is the <b>default</b> .
	<b>METER (C2)</b> Use Meter Density * CTLp * CPLp / (CTLm * CPLm), defined for proving a Micro Motion Coriolis meter.
	<b>METER (DF)</b> Use Meter Density * Density Factor
	<b>KNOWN PRODUCT</b> Enter a value.



Field	Description
<b>VCF Calculations</b>	Sets if the system performs volume correction factor calculations. If enabled, the resulting outputs are then displayed on the prover report. Click ▼ to display valid values. <b>Note:</b> This selection is applicable <b>only</b> to Liquid Master Meter proving.
	<b>DISABLE</b> The system <b>does not</b> perform volume correction factor calculations. This is the <b>default</b> .
	<b>ENABLE</b> The system performs volume correction factor calculations and displays the resulting outputs on the prover report.
<b>Meter Factor Deviation 1 Limit</b>	Sets the maximum allowed deviation from the initial base meter factor. The <b>default</b> value is <b>0.25%</b> . The system uses this value while performing the proved meter factor deviation checks. Refer to <i>Appendix B, Proving</i> for further information. <b>Notes:</b> <ul style="list-style-type: none"> <li>This stage is performed <b>only</b> if you configure the meter normal flow to a value greater than zero (<b>Aramco-style linearisation</b>).</li> <li>This selection is applicable <b>only</b> to Liquid Master Meter proving.</li> </ul>
<b>Meter Factor Deviation 2 Limit</b>	Sets the maximum allowed deviation from the initial base meter factor. The <b>default</b> value is <b>0.1%</b> . The system uses this value while performing the proved meter factor deviation checks. Refer to <i>Appendix B, Proving</i> for further information. <b>Notes:</b> <ul style="list-style-type: none"> <li>This stage is performed <b>only</b> if you configure the meter normal flow to a value greater than zero (<b>Aramco-style linearisation</b>).</li> <li>This selection is applicable <b>only</b> to Liquid Master Meter proving.</li> </ul>
<b>Meter Factor Reject Timeout</b>	Following a successful prove, this value specifies the time period before the current prove results are automatically accepted and totals are adjusted based on the current prove results. During this time period, the current prove results can be manually <b>ACCEPTED</b> (totals will be adjusted) or <b>ACCEPTED NO ADJUST</b> (no totals adjustment). The <b>default</b> is <b>40</b> seconds. Refer to <i>Appendix B, Proving</i> for further information. <b>Notes:</b> <ul style="list-style-type: none"> <li>This stage is performed <b>only</b> if you configure the meter normal flow to a value greater than zero (<b>Aramco-style linearisation</b>).</li> <li>This selection is applicable <b>only</b> to Liquid Master Meter proving.</li> </ul>

- Click in the hierarchy menu when you finish defining settings. A confirmation dialog box displays.
- Click **Yes** to apply your changes. The PCSetup screen displays.

**Hardware** Hardware settings relate to the Prover I/O module. You use these settings to define how the S600+ processes the pulse inputs to the

prover. Typically, when the pulse count is low (less than 10,000 pulses per round trip), the S600+ uses "Phase Locked Loop" processing. This effectively divides each pulse into smaller parts to ensure accuracy is maintained.

1. Select **Hardware** from the hierarchy menu. The Hardware screen displays.

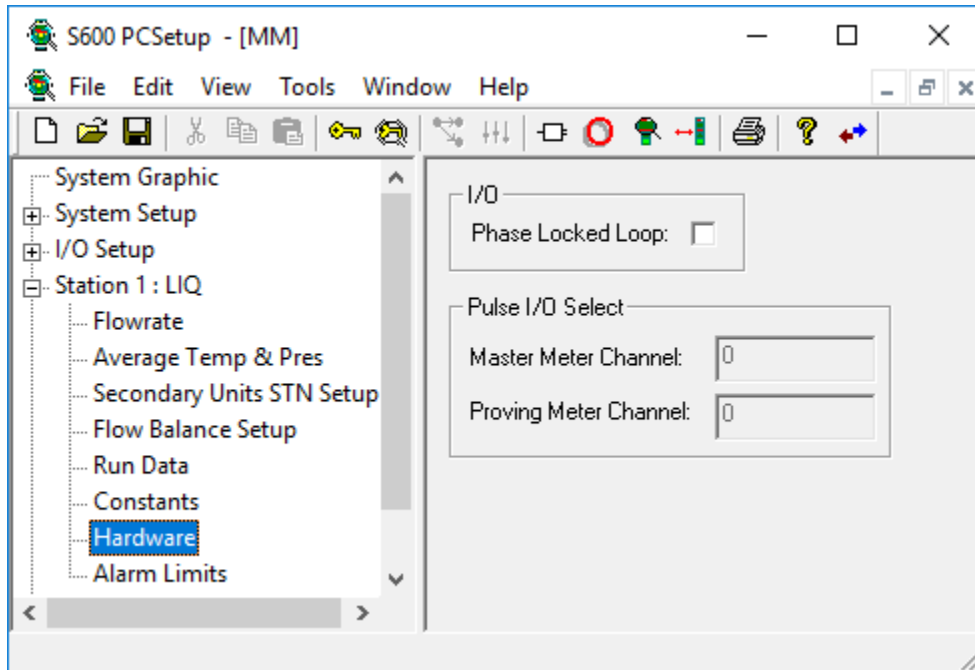

Figure 5-25. Hardware screen (MMeter Prover)

2. Complete the following fields.

Field	Description
<b>Phase Locked Loop</b>	Enables phase locked loops. A phased locked loop multiplies the number of actual turbine pulses by a value for greater accuracy. The default is unchecked ( <b>disabled</b> ).
<b>Master Meter Channel</b>	Indicates the I/O channel to which the S600+ sends pulse I/O information for the Master Meter.
<b>Proving Meter Channel</b>	Indicates the I/O channel to which the S600+ sends pulse I/O information for the proving meter.

3. Click in the hierarchy menu when you finish defining settings. A confirmation dialog box displays.
4. Click **Yes** to apply your changes. The PCSetup screen displays.

**Alarm Limits** The Alarm Limits screen sets the prover alarms. For a description of the alarms, refer to *Alarm Descriptions* in *Chapter 7, Advanced Setup Configuration*.

1. Select **Alarm Limits** from the hierarchy menu. The Alarm Limits screen displays.

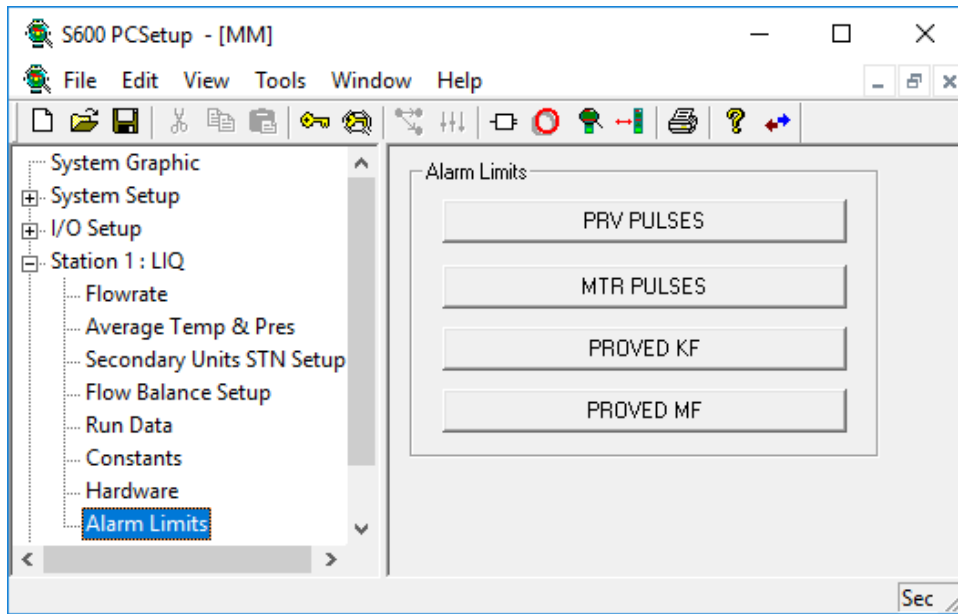

Figure 5-26. Alarm Limits screen (MMeter Prover)

2. Click any of the following buttons to set alarm limits:

Button	Description
<b>PRV PULSES</b>	Click to display a Calculation Result dialog box you use to define the specific alarm limits for prover pulses.
<b>MTR PULSES</b>	Click to display a Calculation Result dialog box you use to define the specific alarm limits for meter pulses.
<b>PROVED KF</b>	Click to display a Calculation Result dialog box you use to define the specific alarm limits for the proved K-factor.
<b>PROVED MF</b>	Click to display a Calculation Result dialog box you use to define the specific alarm limits for the proved Meter Factor.

3. Click in the hierarchy menu when you finish defining alarm limits. A confirmation dialog box displays.
4. Click **Yes** to apply your changes. The PCSetup screen displays.

*[This page is intentionally left blank.]*

## Chapter 6 – Stream Configuration

### In This Chapter

6.1	Initial Configurations.....	6-2
6.2	Common Stream Settings .....	6-4
6.2.1	General Settings.....	6-4
6.2.2	Flowrate.....	6-5
6.2.3	Stream Secondary Units Setup .....	6-7
6.2.4	Stream Flow Switching Setup .....	6-10
6.2.5	Gas Component Flow Weighted Averaging (GC FWA) ..	6-11
6.2.6	Density Measurement.....	6-13
6.2.7	Block Valves .....	6-16
6.2.8	Time & Flow Weighted Averaging Methods.....	6-18
6.3	Gas – Coriolis.....	6-22
6.3.1	AGA8 (Compressibility).....	6-23
6.3.2	Gas CV (ISO6976 or GPA2172/ASTM D3588).....	6-25
6.3.3	Gas CV (AGA5).....	6-30
6.3.4	Stream Gas Composition.....	6-31
6.3.5	Gas Properties .....	6-36
6.3.6	Ethylene.....	6-39
6.3.7	Linearisation .....	6-40
6.3.8	Sampling .....	6-42
6.3.9	Coriolis.....	6-45
6.3.10	Local Units.....	6-49
6.4	Gas – DP.....	6-50
6.4.1	Downstream/Upstream Correction.....	6-50
6.4.2	Pipe Correction.....	6-53
6.4.3	AGA8 (Compressibility).....	6-56
6.4.4	ISO5167 (Mass Flowrate).....	6-59
6.4.5	ISOTR9464.....	6-62
6.4.6	V-Cone (Mass Flowrate) .....	6-64
6.4.7	Annubar (Mass Flowrate).....	6-66
6.4.8	Pure Gas Air .....	6-68
6.4.9	Gas CV (ISO6976 or GPA2172/ASTM D3588).....	6-69
6.4.10	SGERG (Compressibility).....	6-74
6.4.11	NX19 (Compressibility).....	6-77
6.4.12	PTZ (Compressibility).....	6-78
6.4.13	AGA3 (Volume or Mass Flowrate).....	6-80
6.4.14	Stream Gas Composition.....	6-82
6.4.15	Z Steam (Compressibility).....	6-86
6.4.16	GOST CV .....	6-88
6.4.17	GOST Flow.....	6-89
6.4.18	Gas Properties .....	6-92
6.4.19	DP Cell Input Conditioning .....	6-95
6.5	Gas – Turbine .....	6-112
6.5.1	AGA8 (Compressibility).....	6-112
6.5.2	Gas CV (ISO6976 or GPA2172/ASTM D3588).....	6-115
6.5.3	AGA7 (Gross Volume Flowrate).....	6-119
6.5.4	Stream Gas Composition.....	6-122
6.5.5	Gas Properties .....	6-126
6.5.6	Local Units.....	6-129
6.5.7	Linearisation .....	6-129
6.5.8	Sampling .....	6-132
6.6	Gas – Ultrasonic.....	6-135
6.6.1	AGA8 (Compressibility).....	6-136
6.6.2	Gas CV (ISO6976 or GPA2172/ASTM D3588).....	6-138
6.6.3	AGA7 (Gross Volume Flowrate).....	6-143
6.6.4	Stream Gas Composition (Gas Ultrasonic).....	6-145
6.6.5	Gas Properties (Gas Ultrasonic).....	6-149
6.6.6	Local Units.....	6-152
6.6.7	Linearisation .....	6-153

6.6.8	Sampling.....	6-155
6.6.9	Ultrasonic Flow Setup.....	6-158
6.6.10	Ultrasonic Control.....	6-162
6.6.11	QSonc Interface.....	6-163
6.6.12	SICK Control.....	6-164
6.7	Liquid – Coriolis.....	6-167
6.7.1	Local Units.....	6-167
6.7.2	Linearisation.....	6-168
6.7.3	Sampling.....	6-171
6.7.4	Observed Density Correction.....	6-173
6.7.5	Standard Density Correction.....	6-182
6.7.6	Base Sediment and Water (BSW).....	6-188
6.7.7	Coriolis.....	6-189
6.8	Liquid – Turbine.....	6-192
6.8.1	Local Units.....	6-192
6.8.2	Linearisation.....	6-193
6.8.3	Sampling.....	6-196
6.8.4	Observed Density Correction.....	6-199
6.8.5	Standard Density Correction.....	6-207
6.8.6	Base Sediment and Water (BSW).....	6-213
6.9	Liquid - Ultrasonic.....	6-215
6.9.1	Local Units.....	6-215
6.9.2	Sampling.....	6-216
6.9.3	Linearisation.....	6-219
6.9.4	Observed Density Correction.....	6-222
6.9.5	Standard Density Correction.....	6-230
6.9.6	Base Sediment and Water (BSW).....	6-236
6.9.7	Daniel Liquid Ultrasonic.....	6-238
6.10	Modes of Operation.....	6-241
6.10.1	Density Failure Modes.....	6-242

---

Stream settings define the calculation inputs and limits plus alarm setpoints for the stream input data from gas, liquid, and prover applications. Using these settings, the S600+ calculates operational values—including flowrates, density, calorific values and flow-weighted averages—which conform to AGA and ISO calculation standards.



**Caution**

**It is extremely unlikely that any one S600+ configuration would contain all the settings discussed in this section. For that reason, several sample configurations demonstrate the settings.**

---

## 6.1 Initial Configurations

---

The Configuration Generator assigns default settings to the streams in your configuration file. To edit these settings, select the required stream number from the left pane in the PCSetup Editor. Some stream settings are common to all stream types and some are application-specific.

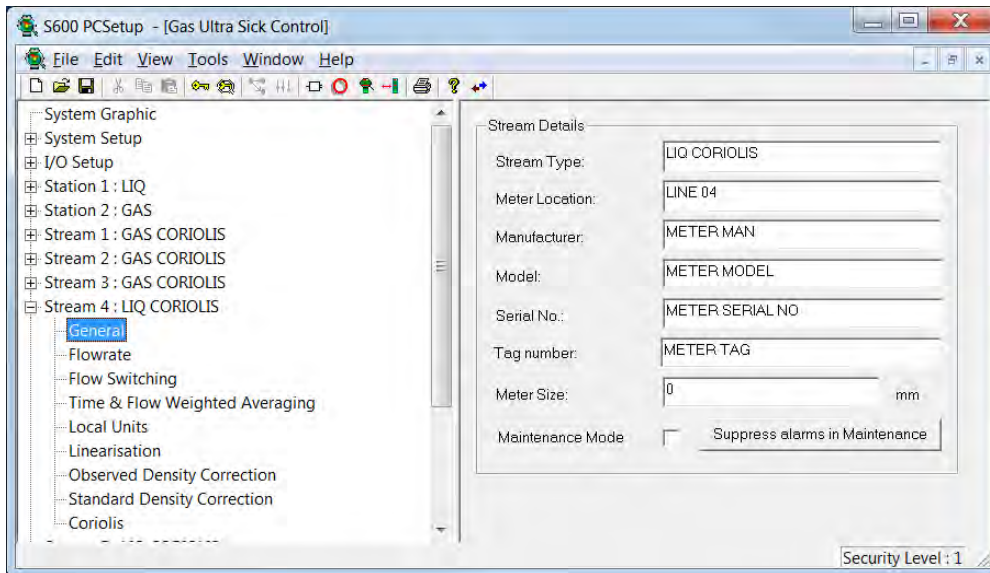

Figure 6-1. Stream Hierarchy screen

Stream settings include:

<p><b>Common Stream Settings</b> (applicable to gas and liquid)</p>	<ul style="list-style-type: none"> <li>▪ General</li> <li>▪ Flowrate</li> <li>▪ Sampling</li> <li>▪ Coriolis</li> <li>▪ Flow Switching</li> <li>▪ Block Valves</li> <li>▪ Time/Flow Weighted Averaging</li> </ul>
<p><b>Gas-Specific Stream Settings</b></p>	<ul style="list-style-type: none"> <li>▪ Downstream/Upstream Correction</li> <li>▪ Pipe Correction</li> <li>▪ Flowrate (for ISO5167, AGA3, Annubar, V-Cone®, or AGA3 US Application)</li> <li>▪ Compressibility (for AGA8, NX-19, PTZ, and SGERG)</li> <li>▪ Gas CV Calorific Value (ISO6976/GPA)</li> <li>▪ Calorific Value (AGA5)</li> <li>▪ GC FWA</li> <li>▪ Gas Composition (Gas Chromatograph)</li> <li>▪ DP Cell Input Conditioning</li> <li>▪ Gas Turbine (AGA7)</li> <li>▪ Linearisation</li> <li>▪ QSonic Interface</li> <li>▪ Ultrasonic Control</li> <li>▪ Ultrasonic Flowrate Setup</li> <li>▪ Z Ethylene</li> <li>▪ Z Stream</li> </ul>
<p><b>Liquid-Specific Stream Settings</b></p>	<ul style="list-style-type: none"> <li>▪ Meter Correction</li> <li>▪ Liquid Volume Correction</li> <li>▪ Linearisation</li> <li>▪ Local Units</li> </ul>

## 6.2 Common Stream Settings

Use the Stream settings to configure the Stream Type, Meter Location, Manufacturer, Model, Serial No., Tag Number, Meter Size, Alarms, Flow rate data, Batching options, Block Values, and Time & Flow Weighted Averaging Techniques.

### 6.2.1 General Settings

Use the General settings screen to define the Meter Location name and Stream Type, indicate various meter-specific values, manage alarms, and configure the initial Maintenance mode setting..

1. Select **General** from the hierarchy menu. Config600 displays the Stream Details settings in the right-hand pane.

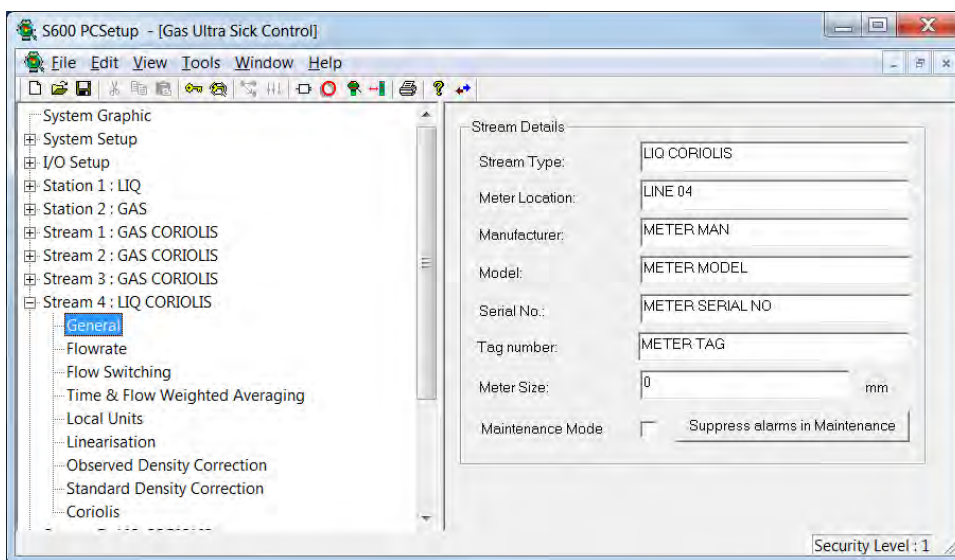

Figure 6-2. General Settings

2. Provide Stream Type and Meter Location descriptions, defining up to 30 alphanumeric characters for each.
3. Provide the Manufacturer, Module, Serial No., Tag Number, Meter Size

---

**Note:** All the values on this screen appear on reports, although you can define Manufacturer, Model, Serial No., Tag Number, and Meter Size **only** for liquid type streams.

---

4. Select Maintenance Mode to force the stream to start up in maintenance mode, in which current maintenance totals **do** increment but normal totals **do not**.

---

**Note:** This is only the **initial** mode of operation. You can change the mode on an operating S600+. You can also override this mode by selecting the Increment Cumulatives in Maintenance Mode check box in the Totalisation section of the PCSetup Editor. To fully enable maintenance mode, you must first define a maintenance mode report.

---



- Click **Suppress alarms in Maintenance** to suppress alarms in maintenance mode. An Alarm Suppression dialog box displays.

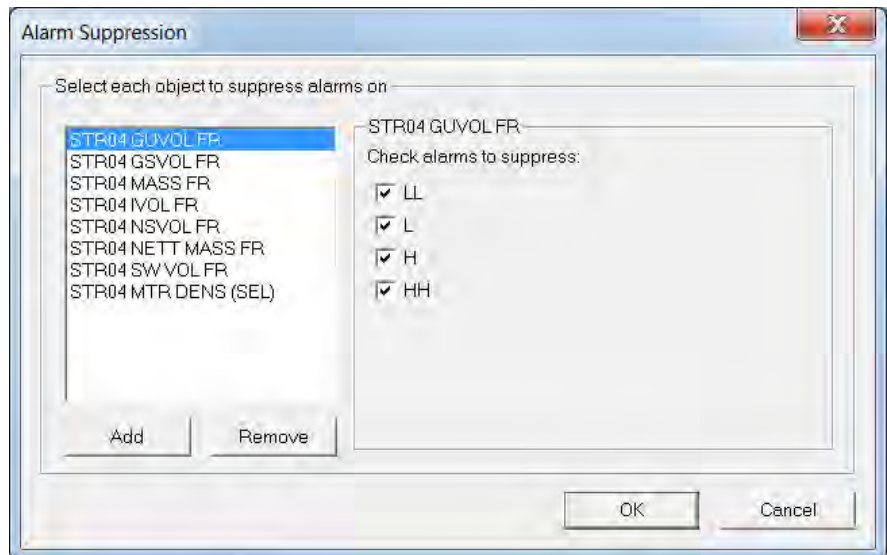

Figure 6-3. Alarm Suppression dialog box

- For each of the objects, select the alarms to suppress. Click **Add** or **Remove** to select or de-select objects from the listing.
- Click **OK** when you finish identifying alarms to suppress. The PCSetup screen displays.
- Click the hierarchy menu when you finish defining settings. A confirmation dialog box displays.
- Click **Yes** to apply your changes. The PCSetup screen displays.

## 6.2.2 Flowrate

Flowrate settings define the alarm setpoints for each type of flowrate. You can define up to four types of alarms for each flowrate, and then enable or disable each alarm. The system activates these alarms when the calculated result for the relevant flowrate is not within the specified limits.

- Select **Flowrate** from the hierarchy menu. The Flowrate Settings screen displays.

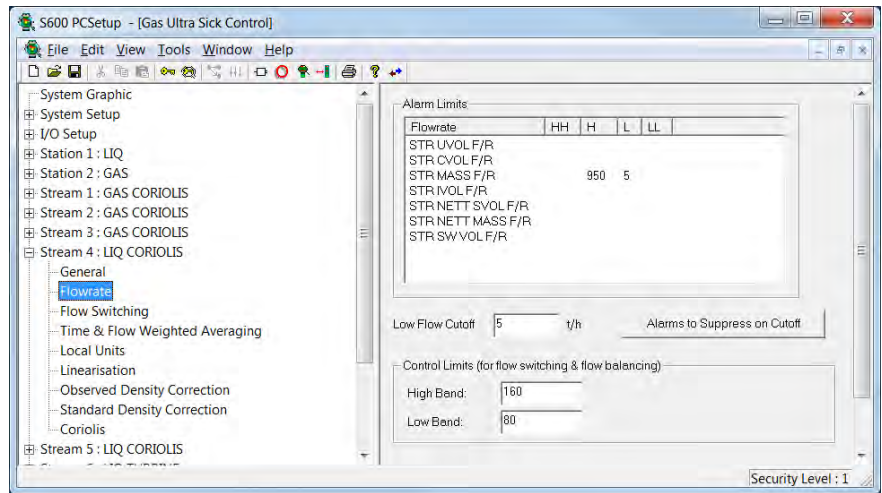

Figure 6-4. Flowrate Settings

2. Double-click a flowrate object in the Alarm Limits pane. A Calculation Result dialog box displays.

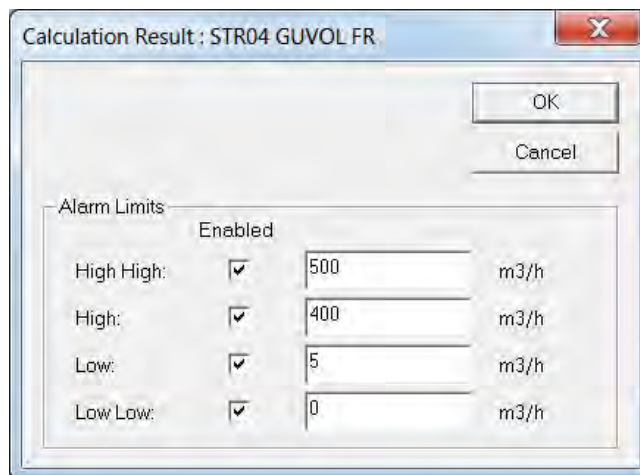

Figure 6-5. Calculation Result dialog box

3. Select the alarms you want to enable and then verify or edit the flowrate associated with that alarm.
4. Click **OK** to apply your changes. The Flowrate Settings screen displays.
5. Complete the **Low Flow Cutoff** field to set a cutoff rate.
6. Click **Alarms to Suppress on Cutoff** if you want to suppress alarms while the flowrate is below the Low Flow Cutoff value. An Alarm Suppression dialog box displays.

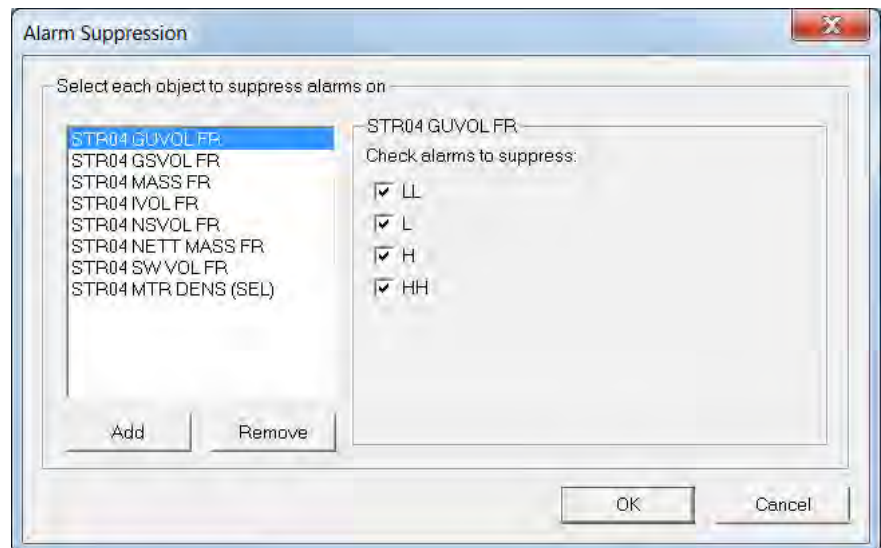

Figure 6-6. Alarm Suppression dialog box

7. Select an object for alarm suppression, and then select the appropriate check boxes. You can define up to 20 objects.
8. Click **OK** when you finish. The Flowrate Settings screen displays.
9. If you are editing a liquid stream, indicate values for the **High Band** and **Low Band** fields. For flow switching, these values set the stream's allowable limits. For flow balancing, these values set the highest and lowest flowrates within which flow balancing functions.
10. Complete the **PID Loop** field to indicate the loop configured to control the flowrate through the selected stream. Click ▼ to display all valid values.

---

**Note:** Be sure to configure the PID.

---

11. Click in the hierarchy menu when you finish defining settings. A confirmation dialog box displays.
12. Click **Yes** to apply your changes. The PCSetup screen displays.

### 6.2.3 Stream Secondary Units Setup

The stream secondary units setup allows for the configuration of selected flow rates and totals in different units as selected in the unit's section.

1. Select the **Secondary Units STR Setup** component from the hierarchy menu. The system displays the associated settings in the right-hand pane.

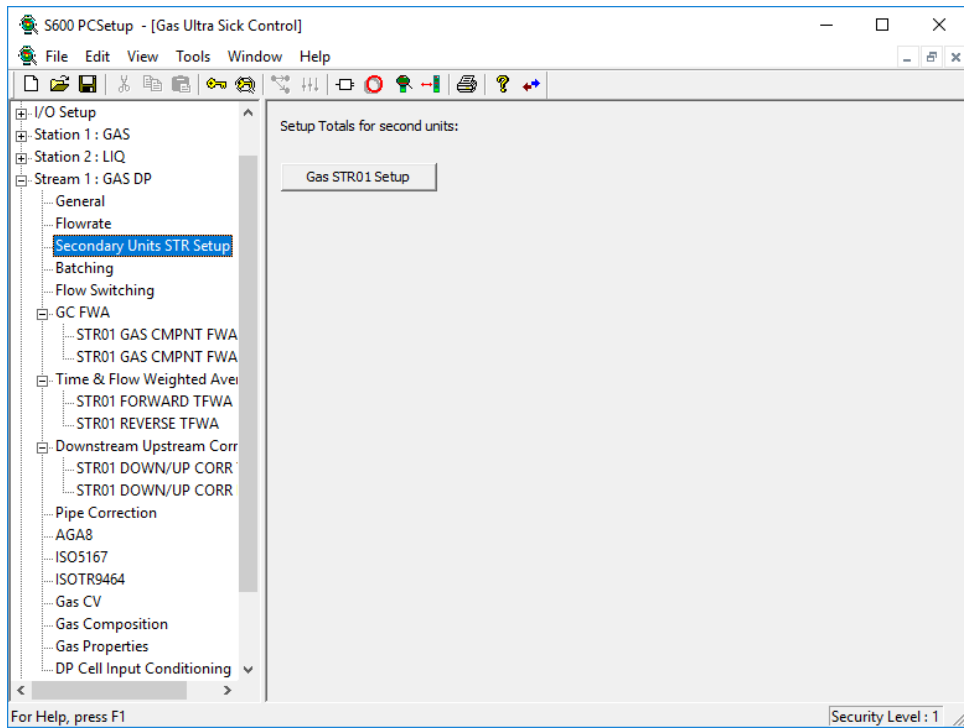

Figure 6-7. Secondary Units STR Setup

2. Select the **Gas STR Setup** or **Liquid STR Setup** button to display the Dual Units Setup dialog.

**Note:** The dialog box consists of two screens (Cumulative Totals and Periodic Totals). You can switch between each screen by selecting the **To Periodic Totals/To Cumulative Totals** button.

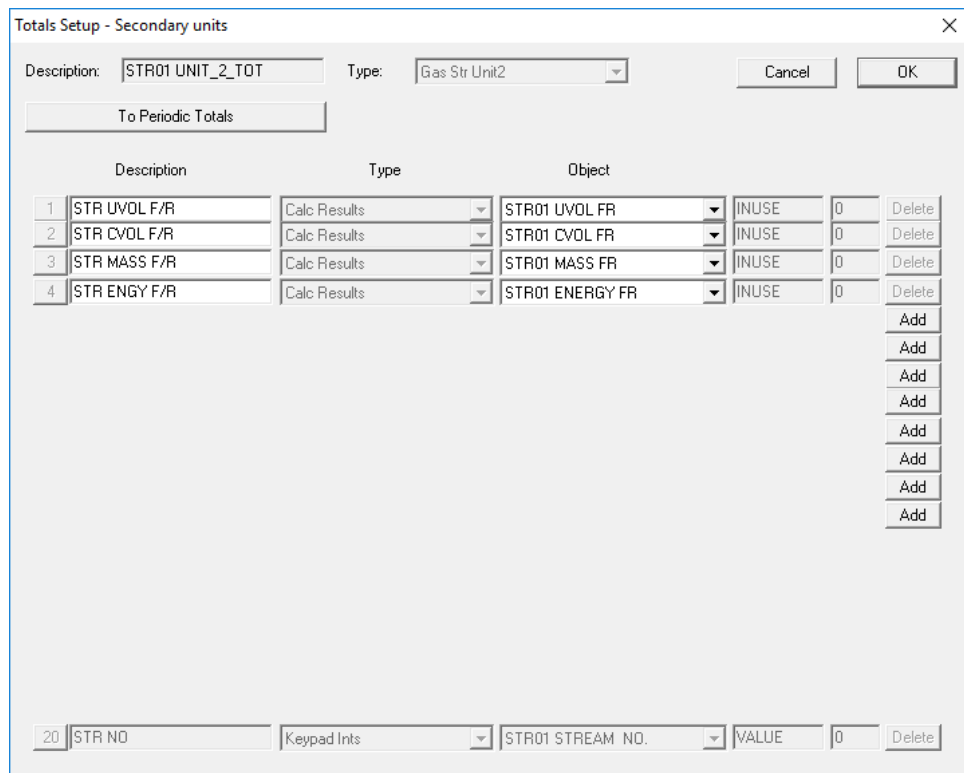

Figure 6-8. Dual Units Setup – Cumulative Totals dialog box

3. The Cumulative Totals screen consists of the following:
  - The first 4 slots are pre-defined and indicate the available flow rates.
  - You can configure the next 8 slots as stream cumulative totals.
  - The last slot is pre-defined and indicates which stream is linked to the selected Dual Units Setup instance.

To add a cumulative total, click on the **Add** button, and the first available cumulative total appears. Use the ▼ button to change the cumulative total for each slot.

**Note:** You should **only** configure Stream Cumulative Totals.

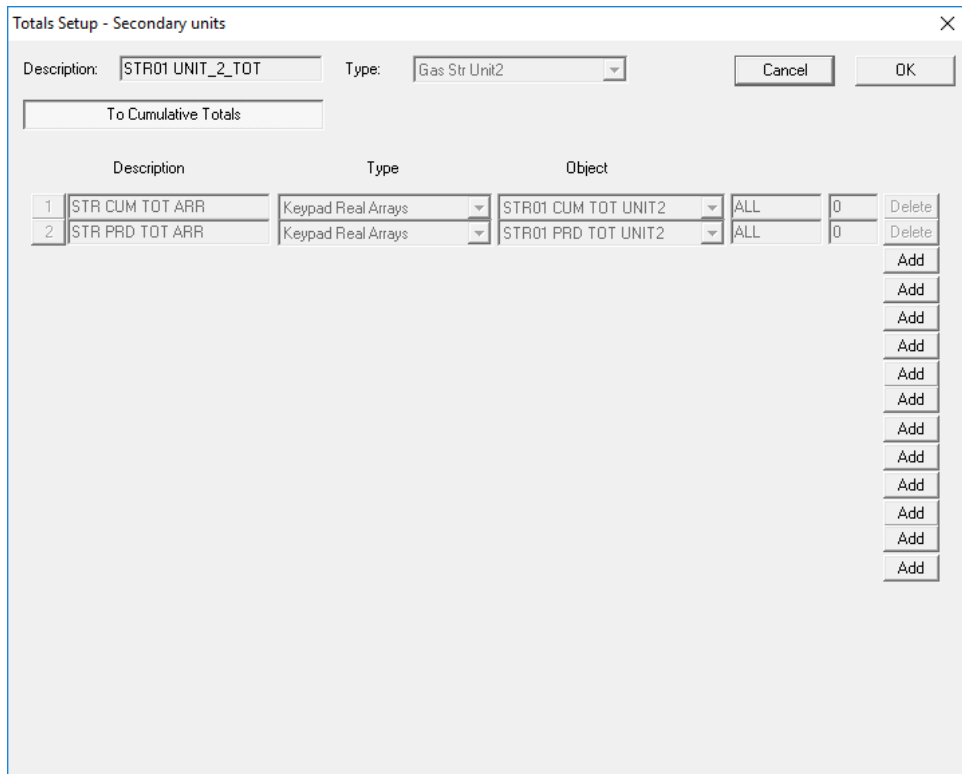

Figure 6-9. Dual Units Setup – Periodic Totals dialog box

4. Click the **To Periodic Totals** button to view the Periodic Totals screen. The Periodic Totals screen consists of the following:
  - Pre-defined Slot 1 is **read-only** and indicates the converted flow rates and cumulative totals.
  - Pre-defined Slot 2 is **read-only** and indicates the converted periodic totals.
  - You can configure the next 12 slots as periodic totals.

To add a periodic total, click on the **Add** button. Use the ▼ button to select the required periodic total.

**Note:** You should **only** configure Periodic Totals belonging to the selected stream.

5. Click **OK** to apply the changes. The PCSetup screen displays.

### 6.2.4 Stream Flow Switching Setup

Flow switching settings define the priorities and number of valves present, as well as control loop specifics. You can set up flow switching for a stream and then disable it until you need this option.

1. Select **Flow Switching** from the hierarchy menu. The Flow Switching screen displays.

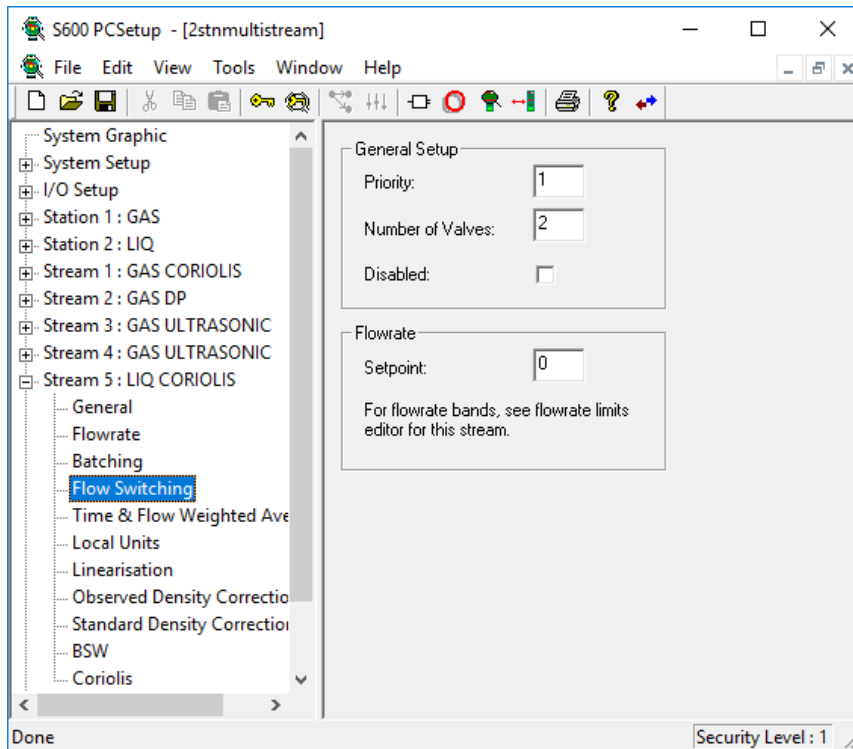

Figure 6-10. Flow Switching screen

2. Complete the following fields.

Field	Description
<b>Priority</b>	Sets the priority of the stream. The higher the number, the higher the stream's priority. For example, 2 has priority over 1, and 3 has priority over 2. The default is <b>1</b> .
<b>Number of Values</b>	Sets the number of values controlled on the selected stream. The default is <b>2</b> .
<b>Disabled</b>	Disables flow switching for the selected stream. The default is unchecked (flow switching is <b>disabled</b> ).
<b>Setpoint</b>	Sets, if applicable, the ideal flowrate required on the selected stream.

3. Click in the hierarchy menu when you finish defining settings. A confirmation dialog box displays.
4. Click **Yes** to apply your changes. The PCSetup screen displays.

### 6.2.5 Gas Component Flow Weighted Averaging (GC FWA)

Gas Component Flow Weighted Averaging (GC FWA) defines how the system averages gas components for a given period. For this option you define two groups of settings, one group for forward flow and one for reverse flow. Select **TFWax4** or **TFWax8** in the Options for Stream screen to configure GC FWA.

1. Select **GC FWA** from the hierarchy menu.
2. Open the option so that you can see both the **FWD** (forward) and **REV** (reverse) settings.

**Note:** Forward and reverse settings are linked. Changes made to settings for either direction are automatically reflected in settings for both directions.

3. Select the **FWD** option. The Gas Component FWA screen displays.

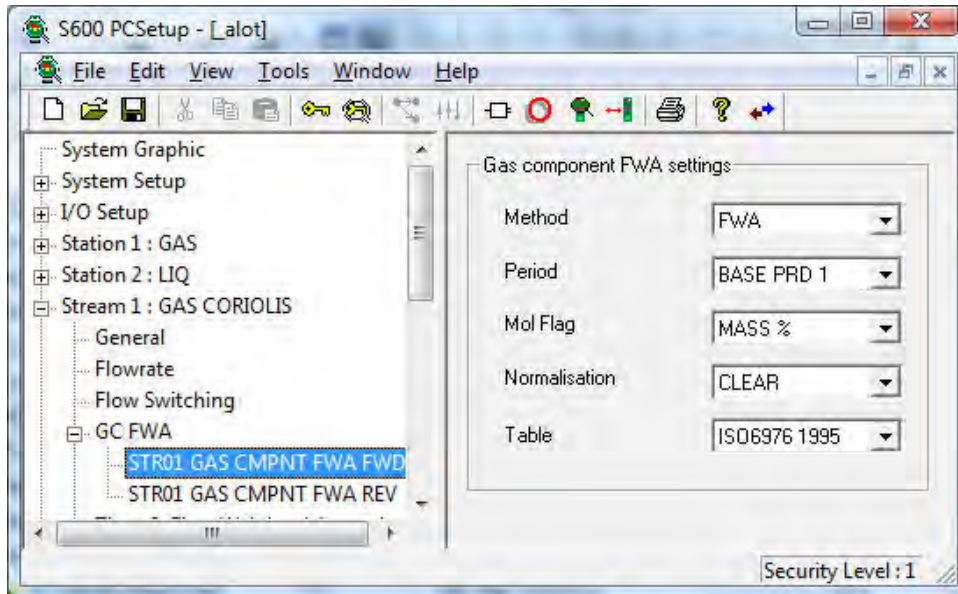

Figure 6-11. Gas Component Flow Weighted Averaging screen

4. Complete the following fields.

Field	Description
<b>Method</b>	<b>FWA</b> Flow weighted averaging, calculated with respect to the total. This is the <b>default</b> value.
	<b>TWA</b> Time weighted averaging, calculated with respect to time and totals. The system calculates this value only when the flowrate is greater than zero.
	<b>TWA-XFLOW</b> Time weighted averaging, calculated with respect only to time. The system calculates this value regardless of the measured flowrate.
	<b>Period</b> Indicates the period for the averaging. Click ▼ to display all options. Select only one period. The default is <b>BASE PRD 1</b> .
<b>Period</b>	<b>BASE PRD 1</b> Bases averaging on the Base Period 1 time period. This is the <b>default</b> .
	<b>BATCH</b> Bases averaging on the batch time period.
	<b>HOURLY</b> Bases averaging on the hourly time period.
	<b>MAINT</b> Based averaging on the time period in maintenance mode.
<b>Mol Flag</b>	Indicates how the system averages the component of each value. Click ▼ to display all options.
	<b>GPA8173</b> Calculates the liquid equivalent volume
	<b>LIQ EQV</b> for each gas component according to



Field	Description
<b>VOL</b>	GPA8173-94.
<b>MASS %</b>	Provides the proportion of each gas component with respect to its molecular mass. The option you select in the Table field provides the component's molecular mass value. This is the <b>default</b>
<b>MOL %</b>	Average based on the mol percentage each component contributes.
<b>TOTALS</b>	Determine component mass totals based on the percentage mass each component contributes. .
<b>Normalisation</b>	Indicates whether the system normalises the output of the components. Click ▼ to display all options. The default is <b>CLEAR</b> (non-normalised).
<b>Table</b>	Indicates the gas table the S600+ uses to provide gas component molecular mass and liquid density values for calculating the component liquid equivalent volumes. Click ▼ to display all options.
<b>ISO6976-1995</b>	Uses ISO6976 2016 gas component molecular mass values. <b>Note:</b> ISO6976 does not provide liquid density values; they default to 0.0.
<b>ISO6976-2016</b>	Uses ISO6976 gas component molecular gas values. This is the <b>default</b> <b>Note:</b> ISO6976 does not provide liquid density values; they default to 0.0.
<b>GPA2145-2009</b>	Uses GPA2145 2009 gas component molecular mass and liquid density values.
<b>GPA2145-2003</b>	Uses GPA2145-2003 gas component molecular gas values.
<b>GPA2145-1994</b>	Uses GPA2145-1994 gas component molecular gas values.

5. Click in the hierarchy menu when you finish defining settings. A confirmation dialog box displays.
6. Click **Yes** to apply your changes. The PCSetup screen displays.

### 6.2.6 Density Measurement

Density Measurement settings define the constants and calculation limits for densitometer inputs. This screen displays when you configure the S600+ to use a densitometer.

1. Select **Density Measurement** from the hierarchy menu.
2. Select **Common Data** from the hierarchy menu. The Densitometer screen displays.

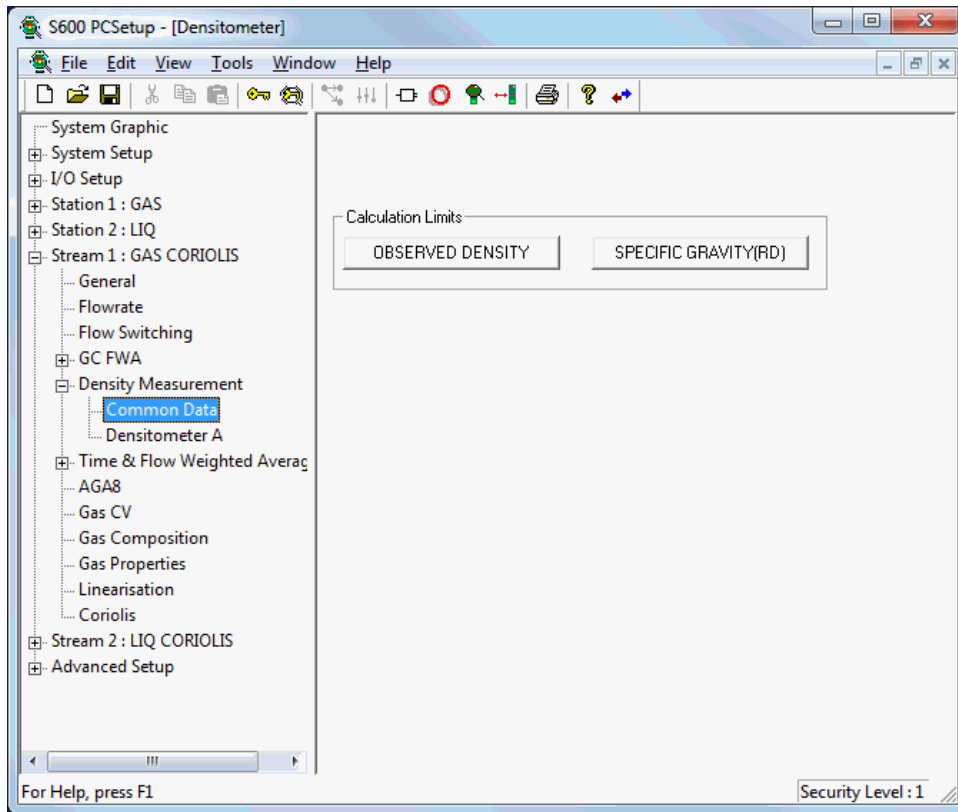

Figure 6-12. Density Measurement Calculation Limits screen

3. Click one of the buttons:

Button	Description
<b>OBSERVED DENSITY</b>	Click to display a Calculation Result dialog box you use to define the mode, keypad value, and the specific alarm limits for observed density.
<b>SPECIFIC GRAVITY(RD)</b>	Click to display a Calculation Result dialog box you use to define the mode, keypad value, and the specific alarm limits for the specific gravity relative density value.

4. Click in the hierarchy menu when you finish defining settings. A confirmation dialog box displays.
5. Click **Yes** to apply your changes.
6. Select **Density Measurement > DensitometerA** or **Densitometer B** from the hierarchy menu. The Density Measurement Densitometer screen displays.

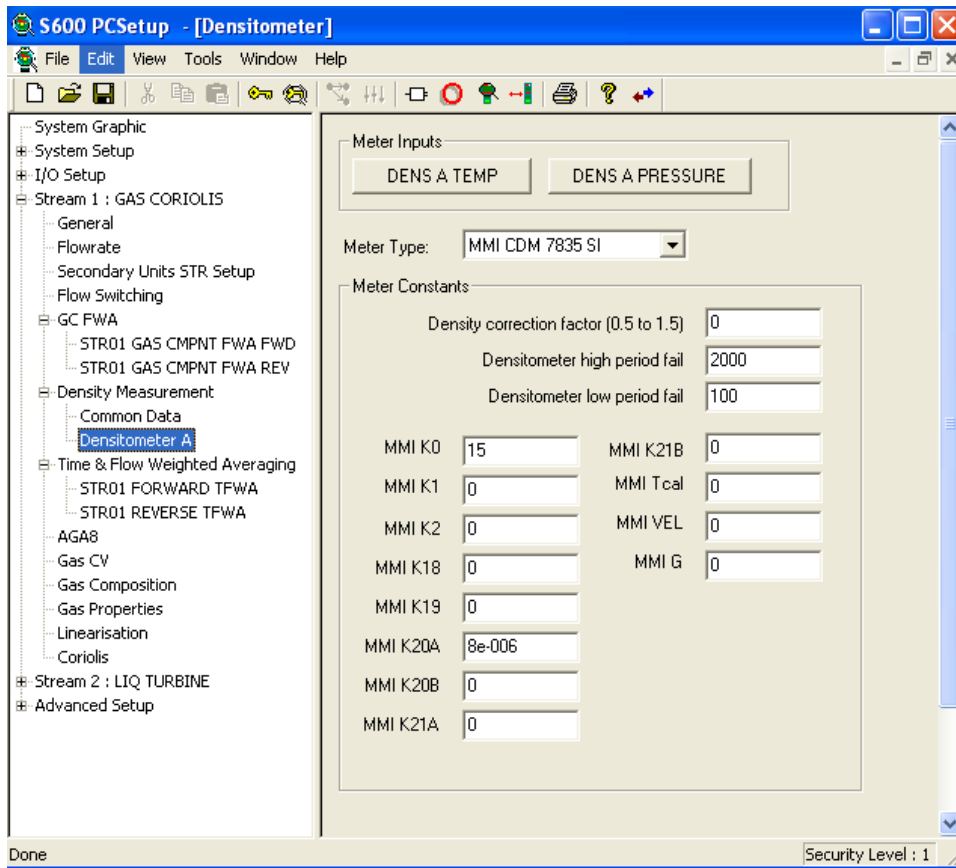

Figure 6-13. Density Measurement Densitometer screen

7. Complete the following fields:

Field	Description
<b>DENS A TEMP/ DENS B TEMP</b>	Click to display the analog input configuration screen to configure the density temperature input and associated values.
<b>DENS A PRESS/ DENS B PRESS</b>	Click to display the analog input configuration screen to configure the density pressure input and associated values.
<b>Meter Type</b>	Indicates the meter associated with each densitometer. Click ▼ to display all valid values:
<b>MMI 3096/98 SI</b>	Micro Motion (formerly Solartron) 3096/98 metric units version.
<b>MMI CDM 7835 SI</b>	Micro Motion (formerly Solartron) 7835/45/46 metric units version.
<b>MMI GDM 7812/28 SI</b>	Micro Motion (formerly Solartron) 7812/28 metric units version.
<b>Sarasota/Peek SI</b>	Sarasota/Peek FD/Anton Paar metric units version.
<b>DENS ANIN</b>	Observed density from analogue input (ADC)
<b>RD ANIN</b>	Observed relative density from an analogue input (ADC)
<b>MMI 3096/98 IMP</b>	Micro Motion (formerly Solartron) 3096/98 Imperial units version.
<b>MMI CDM 7835 IMP</b>	Micro Motion (formerly Solartron) 7835/45/46 Imperial units version.
<b>MMI GDM</b>	Micro Motion (formerly Solartron)

Field	Description
<b>7812/28 IMP</b>	7812/28 Imperial units version.
<b>Sarasota/Peek IMP</b>	Sarasota/Peek FD/Anton Paar Imperial units version.
<b>MMI CDM 7835 DPT SI</b>	Micro Motion (formerly Solartron) 7835 metric pressure-temperature coupling version.
<b>MMI GDM 7835 DPT IMP</b>	Micro Motion (formerly Solartron) 7835 imperial pressure-temperature coupling version.
<b>Density correction factor (0.5 to 1.5)</b>	Sets the value between 0.5 and 1.5 to scale the calculated density at the densitometer. The default value is <b>0</b> .
<b>Densitometer high period fail</b>	Sets the limits of measured period value above which the densitometer must reach before it fails. Default value is <b>2000</b> . Refer to <i>Density Failure Modes</i> .
<b>Density low period fail</b>	Sets the limits of measured period value below which the densitometer must reach before it fails. Default value is <b>100</b> . Refer to <i>Density Failure Modes</i> .
<b>Specific meter constants</b>	Sets calibration constants for the selected densitometer. Each densitometer type has its own calibration constants. <b>Note:</b> The meter manufacturer provides these constants, which are mandatory for the correct functioning of the density calculations.

8. Click in the hierarchy menu when you finish defining these settings. A confirmation dialog box displays.
9. Click **Yes** to apply your changes.

### 6.2.7 Block Valves

Block valve settings define the type of valves used as well as any associated settings and alarms. The system activates these alarms when the relevant timers expire or when the status is different than expected.

1. Select **Block Values** from the hierarchy menu. The Block Valves screen displays.

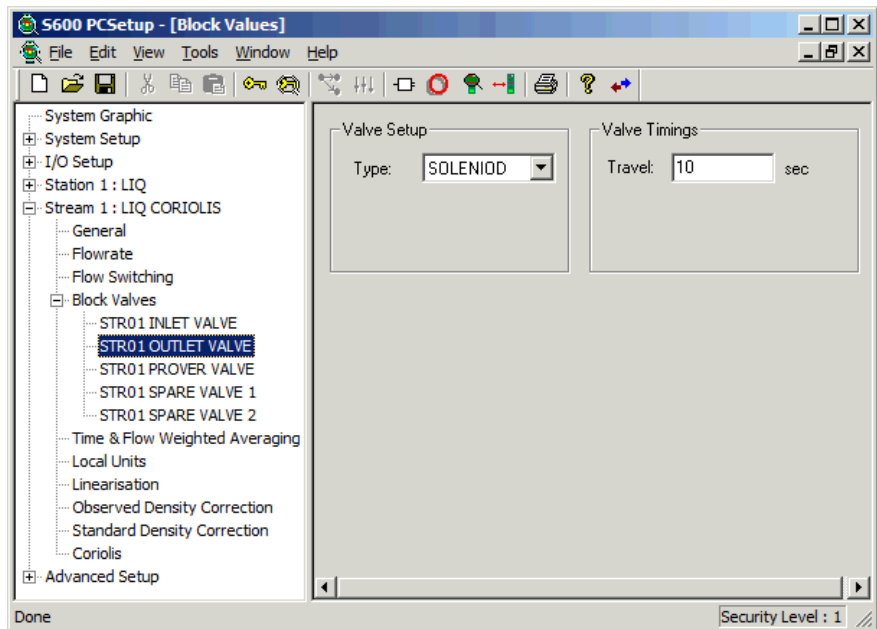

Figure 6-14. Block Valves screen

2. Select a valve setup type.

Field	Description
<b>Type</b>	Indicates the valve setup type. Click ▼ to display all valid values.
<b>MOV</b>	Motorised valve that uses separate opened and closed status inputs as well as separate open and close commands. This is the <b>default</b> .
<b>SOLENOID</b>	Valve that uses separate opened and closed status inputs and a single open command.
<b>PRV 4-WAY</b>	Four-way prover valve that uses separate forward and reverse (home) inputs and separate forward and reverse commands. <b>Note:</b> The PRV 4-WAY is the only valid valve choice when the configuration type is BiDi Prover and for use with the four-way valve.

3. Provide a Valve Timings value.

Field	Description
<b>Travel</b>	Sets, in seconds, the maximum allowed stroke time for the valve to move from fully closed to fully open or from fully open to fully closed before raising a timeout alarm.
<b>Settle</b>	Sets, in seconds, the settling time allowed from the valve reaching its closed limit (or any limit for a 4-way valve) before the test seal is applied. <b>Note:</b> Contact technical support to configure valve seal checking or valve local remote selection.
<b>Test</b>	Sets, in seconds, the seal test active time which starts when the Settle time has elapsed.

4. If seal checking is required, select from the following options.

**Note:** Seal checking, which determines if a seal is leaking, is performed only during test time.

---

Field	Description
No Seal	No seal checking is performed.
Dig Seal	Uses a digital input to determine if the seal has failed.
Diaphragm Press Seal	Uses an analog input to measure the diaphragm pressure. If this option is selected, then a new window opens to allow entry of the Diaphragm Pressure Limit. If the analog input falls below this limit, then a seal fail alarm is raised.



5. Click in the hierarchy menu when you finish defining settings. A confirmation dialog box displays.
6. Click **Yes** to apply your changes. The PCSetup screen displays.

### 6.2.8 Time & Flow Weighted Averaging Methods

Time and Flow Weighted Averaging settings define the stream inputs the system uses to calculate the time-weighted or flow-weighted averages for a given reporting period. You can define a maximum of four stream inputs.

**Note:** Use the System Editor to configure additional change FWA calculations.

---

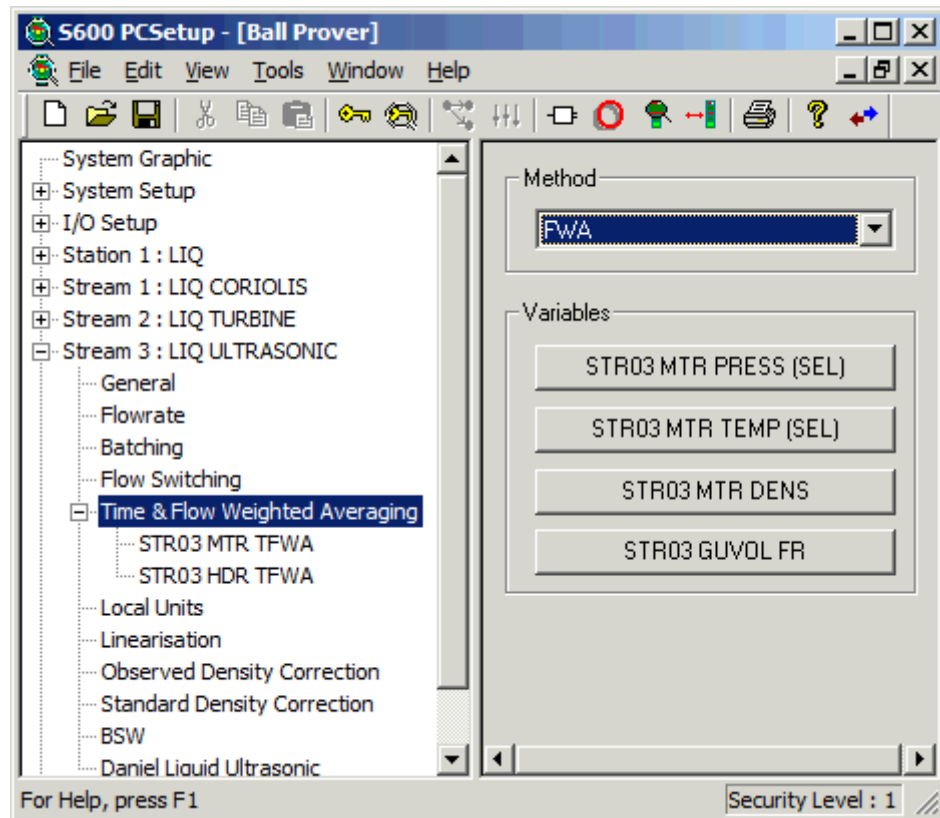

Figure 6-15. Time & Flow Weighted Averaging Example

**Averaging Methods** Config600 provides three methods to calculate the weighted average: flow-weighted (FWA), time-weighted (TWA), and a combination (TWA-XFLOW).

**Notes:**

- Depending on the method you select, Config600 also computes a 60-minute rolling average for each object. Refer to *Chapter 4, I/O and Comms Configuration*.
- The system requires sufficient accumulated flow in order to calculate a flow-weighted average. If there is not enough accumulated flow to calculate a flow-weighted average, the system uses a flow-weighted average of 1.0.

**Flow-Weighted Averaging (FWA)**

For each period type, the algorithm multiplies the elapsed total for the period (that is, flowrate x time) by the present FWA value to give the “weight” for the average. The latest measured value, when multiplied by the elapsed total since the algorithm ran, provides the new “weight” to be incorporated into the whole.

Delta = cumulative total – last snapshot of cumulative total

If Delta > 0.0 then invoke the flow weighted algorithm:

$$FWA = ((FWA \text{ period total} * FWA) + (\text{process var} * \text{delta})) / (FWA \text{ period total} + \text{delta})$$

$$FWA \text{ period total} = FWA \text{ period total} + \text{delta}$$

$$\text{Last snapshot of cumulative total} = \text{cumulative total}$$

As an example, steady flowrate = 360 m<sup>3</sup>/hour, initial temperature = 15 deg.C, increasing at 0.1 deg.C every second, present FWA = 15.0

At 00:00:00, cumulative total = 0.0, FWA period total = 0.0, t = 15.0, FWA=15.0  
No action (FWA remains at 15.0)

At 00:00:01, cumulative total=0.1, FWA period total = 0.0, t = 15.1, FWA=15.0  
Delta = 0.1 – 0.0 = 0.1

$$\text{FWA} = (0.0 * 15.0) + (15.1 * 0.1) / (0.0 + 0.1) = 15.1$$

$$\text{FWA period total} = 0.0 + 0.1 = 0.1$$

At 00:00:02, cumulative total= 0.2, FWA period total = 0.1, t = 15.2, FWA=15.1  
Delta = 0.2 – 0.1 = 0.1

$$\text{FWA} = (0.1 * 15.1) + (15.2 * 0.1) / (0.1 + 0.1) = 15.15$$

$$\text{FWA period total} = 0.1 + 0.1 = 0.2$$

At 00:00:03, cumulative total= 0.3, FWA period total = 0.2, t = 15.3, FWA=15.15  
Delta = 0.3 – 0.2 = 0.1

$$\text{FWA} = (0.2 * 15.15) + (15.3 * 0.1) / (0.2 + 0.1) = 15.2$$

$$\text{FWA period total} = 0.2 + 0.1 = 0.3$$

At 00:00:04, cumulative total= 0.4, FWA period total = 0.3, t = 15.4, FWA=15.2  
Delta = 0.4 – 0.3 = 0.1

$$\text{FWA} = (0.3 * 15.2) + (15.4 * 0.1) / (0.3 + 0.1) = 15.25$$

$$\text{FWA period total} = 0.3 + 0.1 = 0.4$$

### Time-Weighted Averaging (TWA)

The S600+ calculates TWA **only** when the flowrate is **greater than zero**. For each period type, the algorithm multiplies the elapsed time for the period by the present TWA value to give the “weight” for the average. The latest measured value, when multiplied by the elapsed time since the algorithm ran, gives the new “weight” to be incorporated into the whole.

Delta = time interval since task last run

If flowrate > 0.0 then

$$\text{TWA} = ((\text{period time} * \text{TWA}) + (\text{process var} * \text{delta})) / (\text{period time} + \text{delta})$$

$$\text{period time} = \text{period time} + \text{delta}$$

As an example, steady flowrate = 360 m<sup>3</sup>/hour, initial temperature = 15 deg.C, increasing at 0.1 deg.C every second, present TWA = 15.0

At 00:00:00, TWA period time = 0.0, t = 15.0, TWA=15.0

No action (TWA remains at 15.0)

At 00:00:01, TWA period time = 0.0, t = 15.1, TWA=15.0

$$\text{Delta} = 0.1 – 0.0 = 0.1$$

$$\text{TWA} = (0.0 * 15.0) + (15.1 * 0.1) / (0.0 + 0.1) = 15.1$$

$$\text{TWA period time} = 0.0 + 0.1 = 0.1$$

At 00:00:02, TWA period time = 0.1, t = 15.2, TWA=15.1

$$\text{Delta} = 0.2 – 0.1 = 0.1$$

$$\text{TWA} = (0.1 * 15.1) + (15.2 * 0.1) / (0.1 + 0.1) = 15.15$$

$$\text{TWA period time} = 0.1 + 0.1 = 0.2$$

At 00:00:03, TWA period time = 0.2, t = 15.3, TWA=15.15

$$\text{Delta} = 0.3 – 0.2 = 0.1$$

$$\text{TWA} = (0.2 * 15.15) + (15.3 * 0.1) / (0.2 + 0.1) = 15.2$$

$$\text{TWA period time} = 0.2 + 0.1 = 0.3$$



At 00:00:04, TWA period time = 0.3, t = 15.4, TWA=15.2

$$\Delta = 0.4 - 0.3 = 0.1$$

$$TWA = (0.3 * 15.2) + (15.4 * 0.1) / (0.3 + 0.1) = 15.25$$

$$TWA \text{ period time} = 0.3 + 0.1 = 0.4$$

### Time-Weighted Averaging – XFLOW (TW-XFLOW)

The S600+ calculates TWA-XFLOW regardless of the measured flowrate. The algorithm used is the same as that for TWA, with the exception that the system **does not** check if the flowrate is greater than zero. Refer to the TWA description for an example.

**Note:** The methods detailed for flow and time weighted averaging should yield the same results as those specified for the linear averaging as detailed in API (September 1993) Chapter 21, Appendix B. The system supports formulas for both flow-dependent time weighted linear average (B.1.1 a) and flow-dependent flow weighted linear average (B.1.1.c).

**Weighted Averaging Screen** To access this screen:

1. Select **Time/Flow Weighted Averaging** from the hierarchy menu.
2. Select a stream. The Weighted Averaging screen displays.

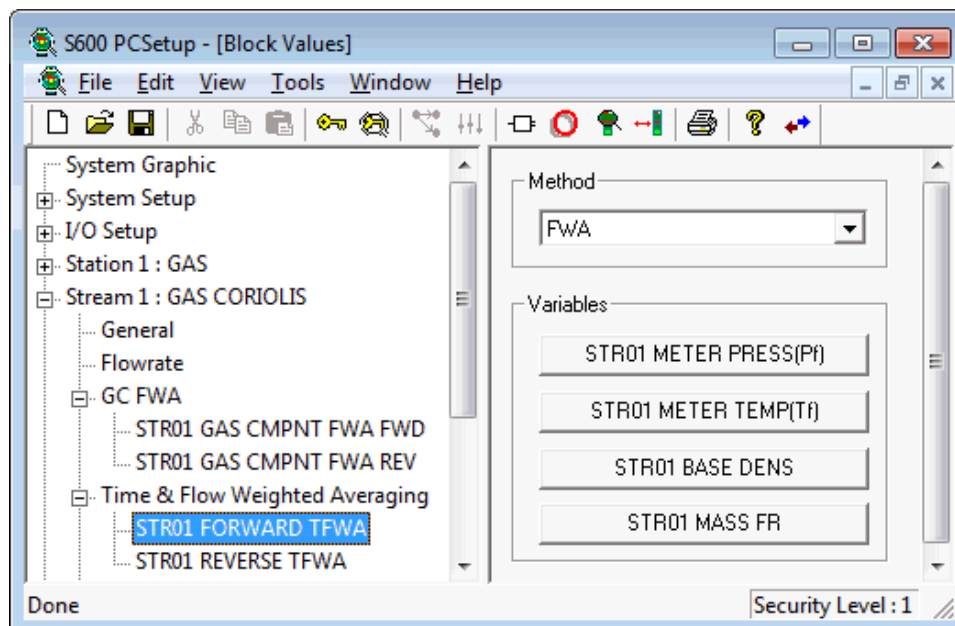

Figure 6-16. Weighted Averaging screen

3. Complete the following field:

Field	Description
Method	Indicates the averaging method. Click ▼ to display all valid values.
FWA	Flow weighted averaging, calculated with respect to the total. This is the <b>default</b> value.

Field	Description
<b>TWA</b>	Time weighted averaging, calculated with respect to time and totals. The system calculates this value only when the flowrate is greater than zero.
<b>TWA-XFLOW</b>	Time weighted averaging, calculated with respect only to time. The system calculates this value regardless of the measured flowrate.

- Click any of the following buttons to define variables:

**Note:** Forward and reverse settings are linked. Changes made to settings for either direction are automatically reflected in settings for both directions.

Button	Description
<b>METER PRESSURE (Pf)</b>	Click to display a Select Object dialog box you use to review or re-associate an object type with an object for meter pressure. <b>Note:</b> The <b>STR01</b> label changes based on the selected stream.
<b>METER TEMP (Tf)</b>	Click to display a Select Object dialog box you use to review or re-associate an object type with an object for meter temperature. <b>Note:</b> The <b>STR01</b> label changes based on the selected stream/application type.
<b>BASE DENS</b>	Displays a Select Object dialog box you use to review or re-associate an object type with an object for base density. <b>Note:</b> The <b>STR01</b> label changes based on the selected stream.
<b>MASS FR</b>	Displays a Select Object dialog box you use to review or re-associate an object type with an object for mass flowrate. <b>Note:</b> The <b>STR01</b> label changes based on the selected stream.

**Note:** The system automatically applies any changes to TWFA assignments to reports. Any unassigned average variables are hidden on the live reports and displays.

- Click in the hierarchy menu when you finish defining settings. A confirmation dialog box displays.
- Click **Yes** to apply your changes. The PCSetup screen displays.

### 6.3 Gas – Coriolis

---

These stream settings are specific to gas applications using a Coriolis meter. When you initially create a configuration, the calculation selections you make determine which calculation screens appear in the hierarchy menu.



**It is extremely unlikely that any one S600+ configuration would contain all the settings discussed in this section. For that reason, settings are demonstrated using a number of example configurations.**

### 6.3.1 AGA8 (Compressibility)

Compressibility settings define the constants and calculation limits for a range of parameters including pressure, temperature, density, and compressibility factors. This screen displays when you configure the S600+ to use the main AGA8 standard to calculate base compressibility, standard compressibility, and flowing compressibility for natural gases.

**Note:** Standard conditions are assumed as 14.73 psia and 60° F.

The compressibility settings also allow you to define alarms. The system activates these when the calculated results are not within the specified limits.

1. Select **AGA8** from the hierarchy menu. The AGA8 screen displays.

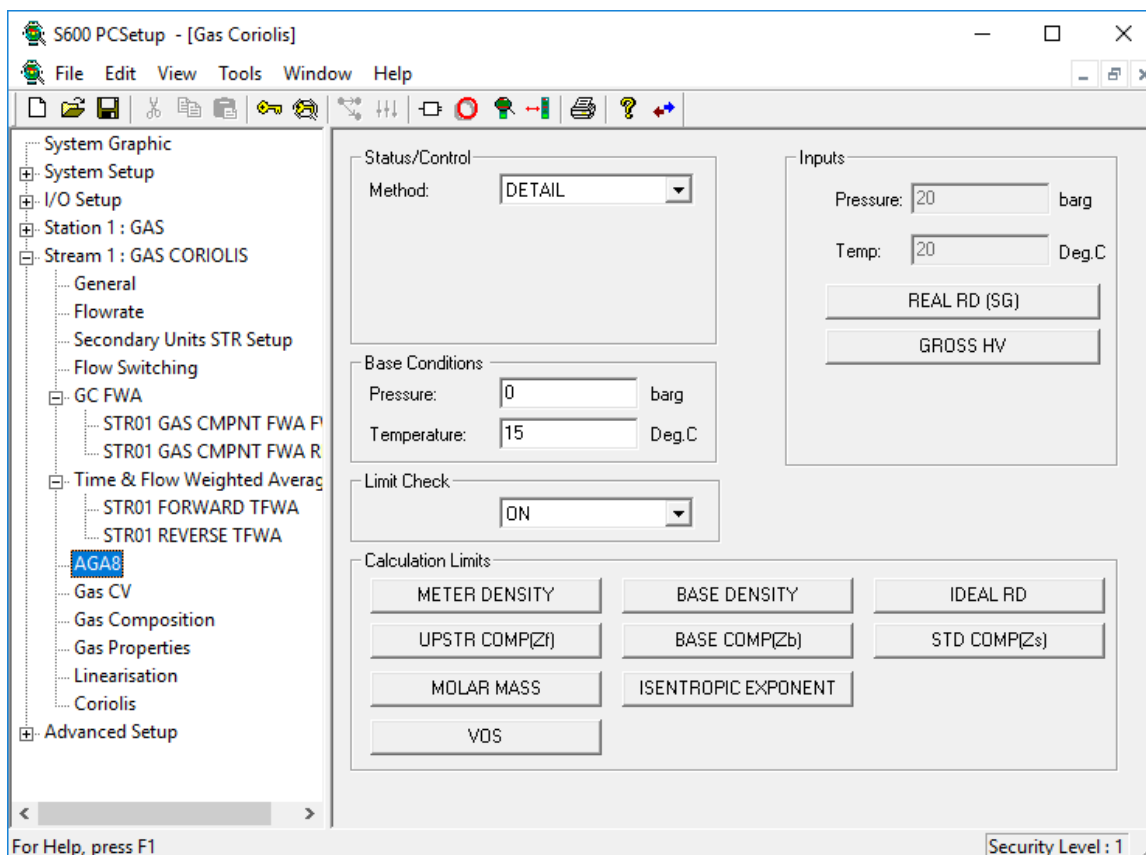

Figure 6-17. AGA8 (Compressibility) screen

2. Complete the following fields.

Field	Description
<b>Status/Control Method</b>	Indicates the compressibility method. Click ▼ to display all valid values.
<b>DETAIL</b>	Uses 21 component values, temperature and pressure in accordance with the 1994

Field	Description
	standard. This is the <b>default</b> .
<b>GROSS1</b>	Uses SG, Heating Value, CO <sub>2</sub> , temperature and pressure in accordance with the 1991 standard. <b>Note:</b> Gross1 only supports volumetric heating value and does not support mass heating value.
<b>GROSS2</b>	Uses SG, N <sub>2</sub> , CO <sub>2</sub> , temperature and pressure in accordance with the 1991 standard.
<b>VNIC</b>	Uses 20 component values, temperature and pressure in accordance with GOST 30319 1996.
<b>MGERG</b>	Uses 19 component values (As indicated in GERG Technical Monograph 2 1998) to calculate compressibility of natural gas mixtures based on a full compositional analysis.
<b>PT 1 DETAIL 2017</b>	Uses 21 component values, temperature and pressure in accordance with the 2017 standard.
<b>PT 1 GROSS1 2017</b>	Uses SG, Heating Value, CO <sub>2</sub> , temperature and pressure in accordance with the 2017 standard. <b>Note:</b> Gross1 only supports volumetric heating value and does not support mass heating value.
<b>PT 1 GROSS2 2017</b>	Uses SG, N <sub>2</sub> , CO <sub>2</sub> , temperature and pressure in accordance with the 2017 standard.
<b>PT 1 GROSS0 2017</b>	Uses 21 component values, temperature and pressure in accordance with the 2017 standard.
<b>PT 2 GERG 2008</b>	Uses 21 component values [as indicated in Table 1 AGA8 2017 Part 2 (GERG 2008)] to calculate compressibility of natural gas mixtures based on a full compositional analysis.
<b>Pressure (Standard)</b>	Sets the pressure under standard conditions. The default is <b>0</b> .
<b>Temperature (Standard)</b>	Sets the temperature under standard conditions. The default is <b>15</b> .
<b>Limit Check</b>	Disables the system's calculation limit checking. The default is <b>On</b> (enabled). <b>Note:</b> Compressibilities and densities are less accurate and calculations may fail when operating outside the calculation limits.
<b>Pressure (Inputs)</b>	Sets the current pressure used to calculate compressibility and density at flowing conditions. <b>Note:</b> On some streams this field may be <b>read-only</b> as this reflects the pressure in use when the flow computer is operational.
<b>Temp (Inputs)</b>	Sets the current temperature used to calculate compressibility and density at flowing conditions. <b>Note:</b> On some streams this field may be <b>read-only</b> as this reflects the pressure in use when the flow computer is operational.

Field	Description
<b>REAL RD (SG)</b>	Click to display a Calculation Result dialog box you use to define the mode, keypad value, and the specific alarm limits for the relative density.
<b>GROSS HV</b>	Click to display a Calculation Result dialog box you use to define the mode, keypad value, and the specific alarm limits for the gross heating value (HV).

3. Click any of the following buttons to set calculation limits:

Button	Description
<b>METER DENSITY</b>	Click to display a Calculation Result dialog box you use to define the mode, keypad value, and the specific alarm limits for the meter density.
<b>UPSTR COMP(Zf)</b>	Click to display a Calculation Result dialog box you use to define the mode, keypad value, and the specific alarm limits for the upstream (flowing) compressibility.
<b>MOLAR MASS</b>	Click to display a Calculation Result dialog box you use to define the mode, keypad value, and the specific alarm limits for the molar mass.
<b>VOS</b>	Click to display a Calculation Result dialog box you use to define the mode, keypad value, and the specific alarm limits for the velocity of sound. <b>Note:</b> This field is visible <b>only</b> if you select either <b>PT1 DETAIL 2017</b> or <b>PT2 GERG 2008</b> in the <b>Status/Control Method</b> field.
<b>BASE DENSITY</b>	Click to display a Calculation Result dialog box you use to define the mode, keypad value, and the specific alarm limits for the base density.
<b>BASE COMP(Zb)</b>	Click to display a Calculation Result dialog box you use to define the mode, keypad value, and the specific alarm limits for the base compressibility.
<b>ISENTROPIC EXPONENT</b>	Click to display a Calculation Result dialog box you use to define the mode, keypad value, and the specific alarm limits for the isentropic exponent. <b>Note:</b> This field is visible <b>only</b> if you select either <b>PT1 DETAIL 2017</b> or <b>PT2 GERG 2008</b> in the <b>Status/Control Method</b> field.
<b>IDEAL RD</b>	Click to display a Calculation Result dialog box you use to define the mode, keypad value, and the specific alarm limits for the ideal relative density.
<b>STD COMP(Zs)</b>	Click to display a Calculation Result dialog box you use to define the mode, keypad value, and the specific alarm limits for the standard compressibility.

4. Click in the hierarchy menu when you finish defining settings. A confirmation dialog box displays.
5. Click **Yes** to apply your changes. The PCSetup screen displays.

### 6.3.2 Gas CV (ISO6976 or GPA2172/ASTM D3588)

Calorific Value (CV) settings define the constants and calculation limits for the ideal and real calorific values. This screen displays when you configure the S600+ to use either the ISO6976 or GPA2172/ASTM D3588 standard (in step 5, Options, of the PCSetup Editor's Configuration Wizard) to calculate the calorific value (heating value) of the gas mixture.

The calorific value settings also allow you to define alarms. The system activates these alarms when the calculated results are not within the specified limits.

1. Select **Gas CV** from the hierarchy menu. The Calorific Value screen displays.

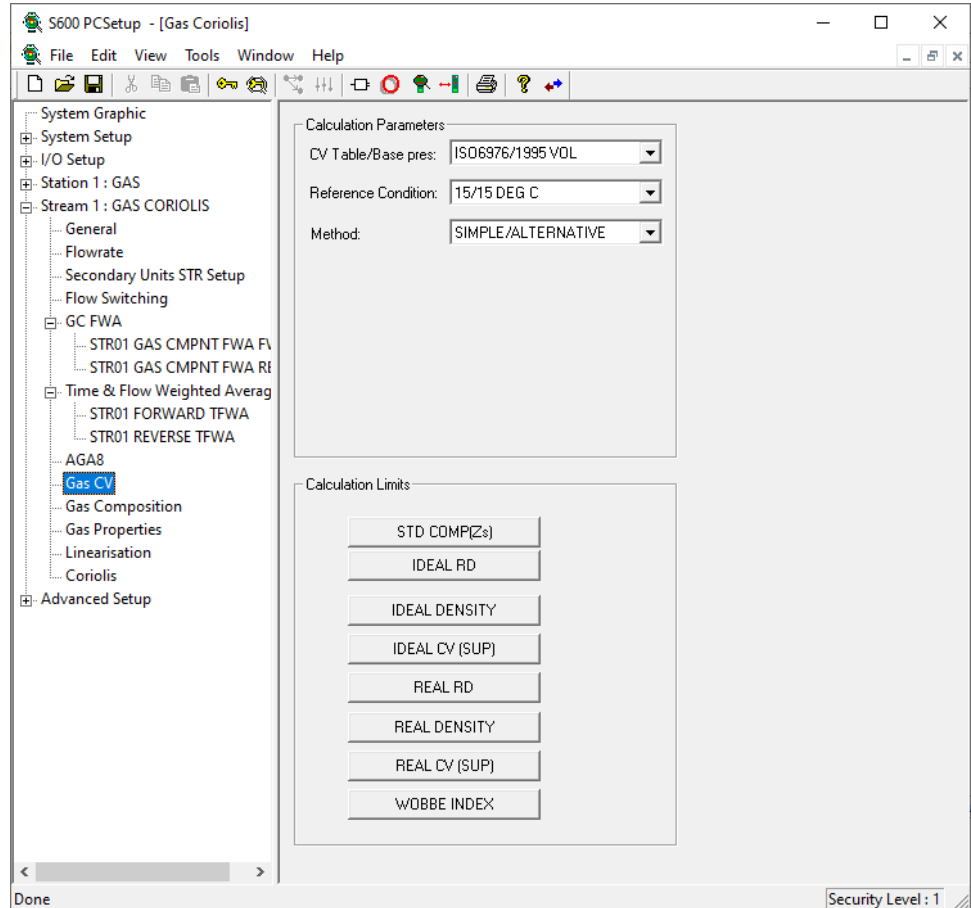

Figure 6-18. Gas CV screen

2. Complete the following fields.

Field	Description
<b>CV Table</b>	Indicates the specific type of GPA scenario calculation the S600+ uses. Click ▼ to display all valid values. <b>Note:</b> Change units and CV table if you want CV in mass units.
<b>ISO6976/1995 Vol</b>	Calculates CV based on volume, using the 1995 table. This is the <b>default</b> if you choose CV ISO6976 as your initial stream option. <b>Note:</b> This option displays <b>only</b> if you initially configure the stream to use <b>CV ISO6976</b> .
<b>ISO6976/1995 Mass</b>	Calculates CV based on mass, using the 1995 table. <b>Note:</b> This option displays <b>only</b> if you initially configure the stream to use <b>CV ISO6976</b> .
<b>ISO6976/1983 Vol</b>	Calculates CV based on volume, using the 1983 table.

Field	Description
	<b>Note:</b> Support for the 1983 table is limited to superior volumetric at 15/15. This option displays <b>only</b> if you initially configure the stream to use <b>CV ISO6976</b> .
<b>ISO6976/2016 Vol</b>	Calculates CV based on volume, using the 2016 table. <b>Note:</b> This option only displays if you initially configure the stream to use <b>CV ISO6976</b> .
<b>ISO6976/2016 Mass</b>	Calculates CV based on mass, using the 2016 table. <b>Note:</b> This option only displays if you initially configure the stream to use <b>CV ISO6976</b> .
<b>GPA/2003 AGA (14.73)</b>	Calculates CV based on a base pressure of 14.73 psia. This is the <b>default</b> if you choose CV GPA2172-ASTMD3588 as your initial stream option. <b>Note:</b> This option displays <b>only</b> if you initially configure the stream to use <b>CV GPA2172-ASTMD3588</b> .
<b>GPA/2003 ISO (14.696)</b>	Calculates CV based on a base pressure of 14.696 psia. <b>Note:</b> This option displays <b>only</b> if you initially configure the stream to use <b>CV GPA2172-ASTMD3588</b> .
<b>GPA/2000 AGA (14.73)</b>	Calculates CV based on a base pressure of 14.73. <b>Note:</b> This option displays <b>only</b> if you initially configure the stream to use <b>CV GPA2172-ASTMD3588</b> .
<b>GPA/2000 ISO (14.696)</b>	Calculates CV based on a base pressure of 14.696 psia. <b>Note:</b> This option displays <b>only</b> if you initially configure the stream to use <b>CV GPA2172-ASTMD3588</b> .
<b>GPA/1996 AGA (14.73)</b>	Calculates CV based on a base pressure of 14.73 psia. <b>Note:</b> This option displays <b>only</b> if you initially configure the stream to use <b>CV GPA2172-ASTMD3588</b> .
<b>GPA/1996 ISO (14.696)</b>	Calculates CV based on a base pressure of 14.696 psia. <b>Note:</b> This option displays <b>only</b> if you initially configure the stream to use <b>CV GPA2172-ASTMD3588</b> .
<b>GPA/2016 Pb (14.65)</b>	Calculates CV based on a base pressure of 14.65 psia. <b>Note:</b> This option displays <b>only</b> if you initially configure the stream to use <b>CV GPA2172-ASTMD3588</b> .

Field	Description
<b>Reference Condition</b>	<p>Indicates the <math>t_1/t_2</math> value, where <math>t_1</math> is the calculation reference temperature for combustion and <math>t_2</math> is the reference condition for metering. Click ▼ to display all valid values. The default is <b>15/15 DEG C</b>.</p> <p><b>Note:</b></p> <ul style="list-style-type: none"> <li>▪ For <b>ISO6976 1983 VOL</b> selection, the 60/60F and 15/15.55 Deg C selections are <b>not</b> supported.</li> <li>▪ For <b>ISO6976 1995 VOL</b> and <b>MASS</b> selections, the 60/60F selection refers to a combustion temperature (<math>t_1</math>) of 60 Deg F and a metering temperature (<math>t_2</math>) of 15 Deg C. The 15/15.55 Deg C selection is not supported.</li> </ul> <p><b>Note:</b> For Binary.app versions <b>prior to 06.30a</b>, the 60/60F selection refers to a combustion temperature (<math>t_1</math>) of 15 Deg C and a metering temperature (<math>t_2</math>) of 15 Deg C.</p> <ul style="list-style-type: none"> <li>▪ For <b>ISO6976 2016 VOL</b> and <b>MASS</b> selections, the 60/60F selection refers to a combustion temperature (<math>t_1</math>) of 60 Deg F and a metering temperature (<math>t_2</math>) of 15 Deg C. The 15/15.55 Deg C selection refers to a combustion temperature (<math>t_1</math>) of 15.55 Deg C (60 Deg F) and a metering temperature (<math>t_2</math>) of 15.55 Deg C (60 Deg F).</li> </ul> <p><b>Note:</b> For Binary.app versions <b>prior to 06.30a</b>, the 60/60F selection refers to a combustion temperature (<math>t_1</math>) of 15 Deg C and a metering temperature (<math>t_2</math>) of 15 Deg C.</p>
<b>Method</b>	<p>If you select CV ISO6976 in your initial configuration and you select the 1995 standard, you have the choice of Alternative or Definitive methods (using table 4 Mass / table 5 volume) for calculating the ideal, superior, and inferior CV values. This selection is not applicable to the 1983 or 2016 standards.</p> <p>If you select <b>CV GPA2172-ASTMD3588</b> in your initial configuration, you have the choice of the Simple (using equation 7 f from the GPA2172-ASTMD3588-09 standard) or Rigorous (using equations 8 &amp; 9 from the GPA2172-ASTMD3588-09 standard) methods for calculating the standard compressibility.</p> <p><b>Note:</b> This option is valid <b>only</b> for configurations created with Config600 version 3.1 or greater.</p>
<b>User Temp T2</b>	<p>Applicable to the <b>ISO6976 2016 VOL</b> and <b>ISO6976 2016 MASS</b> selections. Also applicable to the <b>ISO6976 1995 VOL</b> selection when the Definitive method is selected.</p> <p><b>Note:</b> It may be necessary to add this item to a display so that it can be correctly initialised.</p>
<b>User Press P2</b>	<p>Applicable to the <b>ISO6976 2016 VOL</b> and <b>ISO6976 1995 VOL</b> selections when the Definitive method is selected.</p> <p><b>Note:</b> It may be necessary to add this item to a display so that it can be correctly initialised.</p>



Field	Description
<b>Table Revision</b>	<p>This replaces the above AGA and ISO selections in the CV Table field for GPA 2172. You can select the GPA2145 table revision from one of the following:</p> <ul style="list-style-type: none"> <li>▪ 1996</li> <li>▪ 2000</li> <li>▪ 2003</li> <li>▪ 2009</li> </ul> <p><b>Note:</b> This option is valid <b>only</b> for configurations created with Config600 version 3.1 or greater.</p>
<b>Base Comp(Zb)</b>	<p>Click to supply an externally calculated base compressibility from another calculation. The entered value is used in GPA2172-ASTMD3588 calculations instead of using its own internally calculated value based on the composition input.</p>
<b>Composition Type</b>	<p>Defines the composition input type. Valid options are:</p> <ul style="list-style-type: none"> <li>▪ mass to energy using mole percent</li> <li>▪ mass to energy using mole fraction</li> <li>▪ volume to energy using mole percent</li> <li>▪ volume to energy using mole fraction</li> </ul> <p><b>Note:</b> This option is valid <b>only</b> for AGA5 configurations.</p>

3. Click any of the following buttons to define calculation limits for either the ISO6976 or GPA2172-ASTMD3588 standard.

Button	Description
<b>STD COMP (Zs)</b>	<p>Click to display a Calculation Result dialog box you use to define the mode, keypad value, and the specific alarm limits for standard compressibility (Zs).</p>
<b>IDEAL RD</b>	<p>Click to display a Calculation Result dialog box you use to define the mode, keypad value, and the specific alarm limits for ideal relative density.</p> <p><b>Note:</b> This field displays <b>only</b> if you initially configure the stream to use CV ISO6976.</p>
<b>IDEAL DENSITY</b>	<p>Click to display a Calculation Result dialog box you use to define the mode, keypad value, and the specific alarm limits for ideal density.</p> <p><b>Note:</b> This field displays <b>only</b> if you initially configure the stream to use CV IS6976.</p>
<b>IDEAL CV (SUP)</b>	<p>Click to display a Calculation Result dialog box you use to define the mode, keypad value, and the specific alarm limits for ideal calorific value.</p> <p><b>Note:</b> The superior CV is output to calc field 1 of the CV object and the inferior CV is output to calc field 3. You can select either using the CV object mode from the Front Panel display.</p>
<b>Gross HV</b>	<p>Displays a Calculation Result dialog box you use to define the mode, keypad value, and the specific alarm limits for gross heating value.</p> <p><b>Note:</b> This field displays <b>only</b> if you initially configure the stream to use CV GPA2172-ASTMD3588.</p>

Button	Description
<b>REAL RD</b>	Click to display a Calculation Result dialog box you use to define the mode, keypad value, and the specific alarm limits for real relative density. <b>Note:</b> This field displays <b>only</b> if you initially configure the stream to use CV ISO6976.
<b>REAL DENSITY</b>	Click to display a Calculation Result dialog box you use to define the mode, keypad value, and the specific alarm limits for real density. <b>Note:</b> This field displays <b>only</b> if you initially configure the stream to use CV ISO6976.
<b>REAL CV (SUP)</b>	Click to display a Calculation Result dialog box you use to define the mode, keypad value, and the specific alarm limits for real calorific value. <b>Note:</b> The superior CV is output to calc field 1 of the CV object and the inferior CV is output to calc field 3. You can select either by the CV object mode from the Front Panel display. This field displays <b>only</b> if you initially configure the stream to use ISO6976.
<b>WOBBE INDEX</b>	Click to display a Calculation Result dialog box you use to define the mode, keypad value, and the specific alarm limits for real calorific value. <b>Note:</b> The Wobbe Index is calculated using the Real Superior CV.
<b>REAL VOL IDEAL HV</b>	Click to display a Calculation Result dialog box you use to define the mode, keypad value, and the specific alarm limits for the real volume ideal heating value. <b>Note:</b> This field displays <b>only</b> if you initially configure the stream to use CV GPA2172-ASTMD3588.

4. Click in the hierarchy menu when you finish defining settings. A confirmation dialog box displays.
5. Click **Yes** to apply your changes. The PCSetup screen displays.

### 6.3.3 Gas CV (AGA5)

Calorific Value settings define the constants and calculation limits for ideal and real calorific values. This screen displays when you configure the S600+ to use the AGA5 (CVAGA5) standard to calculate calorific value (heating value) for the gas mixture. )

The calorific value settings also allow you to define alarms. The system activates these alarms when the calculated results are not within the specified limits.

1. Select **Gas CV** from the hierarchy menu. The Calorific Value screen displays.

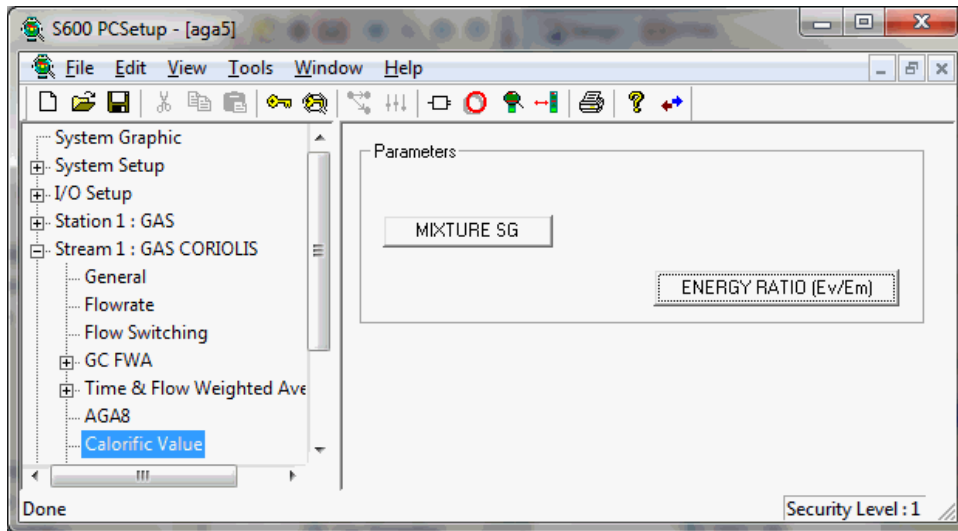

Figure 6-19. Calorific Value screen

2. Click either of the buttons to define calorific value parameters.

Button	Description
<b>MIXTURE SG</b>	Click to display a Calculation Result dialog box you use to define the mode, keypad value, and the specific alarm limits for specific gravity.
<b>ENERGY RATIO</b>	Click to display a Calculation Result dialog box you use to define the mode, keypad value, and the specific alarm limits for the actual calorific value. <b>Note:</b> The energy ratio is equivalent to the real calorific value or real heating value.

3. Click in the hierarchy menu when you finish defining settings. A confirmation dialog box displays.
4. Click **Yes** to apply your changes. The PCSetup screen displays.

### 6.3.4 Stream Gas Composition

Stream Gas Composition settings define the processing and port telemetry parameters for streams receiving data from the gas chromatograph controller. The chromatograph controller measures the individual component concentrations found in the line gas. The chromatograph controller settings also allow you to define alarms. The system activates these alarms when the calculated results for the chromatograph data are not within specified limits.

1. Select **Gas Composition** from the hierarchy menu. The Gas Composition screen displays.

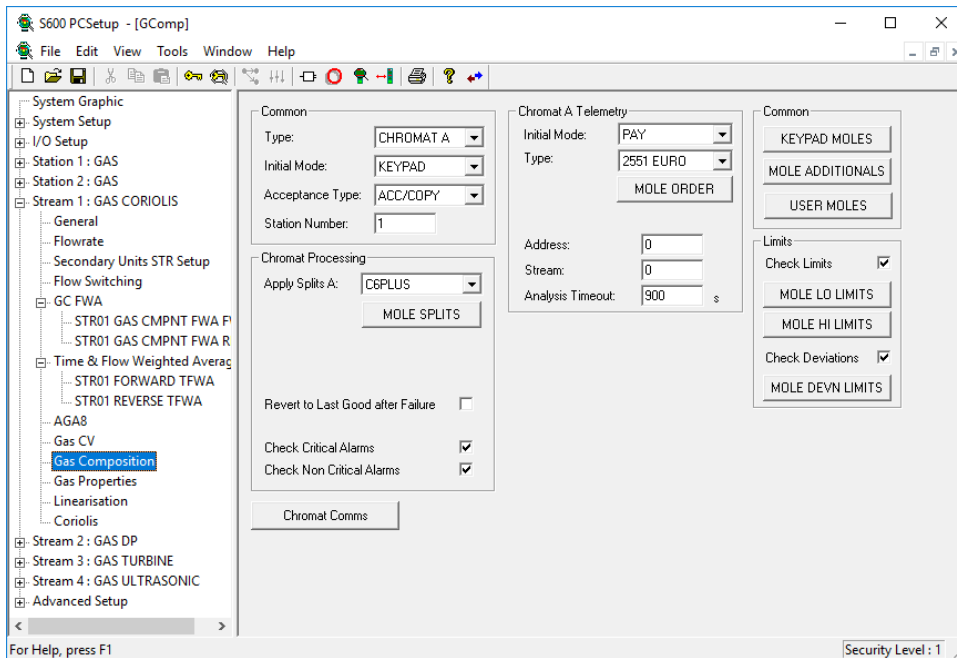

Figure 6-20. Gas Composition screen

2. Complete the following fields.

Field	Description
<b>Type</b>	Indicates the chromatograph configuration. Click ▼ to display all valid values.
<b>CHROMAT A</b>	Controller-connected; uses keypad data as fallback information.
<b>KP ONLY</b>	Not controller-connected; uses information entered via keypad. This is the <b>default</b> .
<b>Note:</b> If you select <b>KP ONLY</b> , the system hides a number of fields on this screen.	
<b>Initial Mode</b>	Indicates the operational mode for the in-use composition data. Click ▼ to display all valid values.
<b>KEYPAD</b>	Use data entered via keypad. This is the <b>default</b> .
<b>CHROMAT</b>	Use live data from the chromatograph controller.
<b>DOWNLOAD</b>	Download gas composition data directly to each stream. Used only if connected to a remote supervisory computer.
<b>USER</b>	Use customised program for gas composition in S600+.
<b>KEYPAD-F</b>	Start by using keypad-entered data then switch to chromatograph data when a good analysis is received.

Field	Description
<b>Acceptance Type</b>	Indicates how the S600+ manages in-use data. Click ▼ to display all valid values.
<b>ACC/COPY</b>	Copy and normalise keypad data to in-use data only after it is accepted. This is the <b>default</b> .
<b>ACC/NORM</b>	Copy normalised keypad data to in-use data after it is accepted.
<b>AUTO/NORM</b>	Automatically copy normalised keypad data to in-use data.
<b>Station Number</b>	Sets the station associated with this stream. The default is <b>1</b> .
<b>Apply Splits</b>	Indicates the type of analyser connected to the S600+. For a C6+ analyser, use the C6Plus option. Click ▼ to display all valid values. The default is <b>NO SPLITS</b> . If you select any value other than <b>NO SPLITS</b> , the system displays the <b>MOLE SPLITS</b> button. Use it to define the specific percentage splits for the gases. <b>Note:</b> This field displays <b>only</b> if you select <b>CHROMAT A</b> as the chromatograph configuration type.
<b>MOLE SPLITS</b>	Click to display a Gas Composition dialog box you use to indicate the mole splits for hexane, heptane, octane, nonane, and decane. <b>Note:</b> This button displays <b>only</b> if you select <b>any value other than NO SPLITS</b> in the Apply Splits field.
<b>Revert to Last Good after Failure</b>	Continues using the last good composition in the event of failure. Otherwise, the system reverts to keypad data.
<b>Check Critical Alarms</b>	Marks the received composition as failed if any critical alarm is set (such as the pre-amp fail on the Danalyzer for a Daniel 2551 Controller). <b>Note:</b> This field displays <b>only</b> if you select <b>CHROMAT A</b> as the chromatograph configuration type.
<b>Check Non Critical Alarms</b>	Marks the received composition as failed if any non-critical alarm is set (such as the pre-amp fail on the Danalyzer for a Daniel 2551 Controller). <b>Note:</b> This field displays <b>only</b> if you select <b>CHROMAT A</b> as the chromatograph configuration type.
<b>CHROMAT COMMS</b>	Click to display the Comm screen in I/O Setup.
<b>Initial Mode</b>	Identifies the chromatograph and any fallback controllers. Currently, the only valid value is <b>PAY</b> , which indicates one chromatograph and no fallback controller. <b>Note:</b> This field displays <b>only</b> if you select <b>CHROMAT A</b> as the chromatograph configuration type.

Field	Description
<b>Type</b>	<p>Indicates the type of chromatograph controller. Click ▼ to display all valid values.</p> <p><b>Note:</b> This field displays <b>only</b> if you select <b>CHROMAT A</b> as the chromatograph configuration type.</p> <hr/> <p><b>2551 EURO</b> S600+ is connected to a Daniel 2551 (European) controller. This is the <b>default</b>.</p> <hr/> <p><b>2350 EURO</b> S600+ is connected to a Daniel 2350 (European) controller set in SIM_2251 mode.</p> <hr/> <p><b>2350 USA</b> S600+ is connected to a Daniel 2350 (USA) controller set in SIM_2251 mode.</p> <hr/> <p><b>2251 USA</b> S600+ is connected to a Daniel 2251 controller.</p> <hr/> <p><b>Generic</b> S600+ is connected to another type of controller.</p> <hr/> <p><b>Siemens</b> S600+ is connected to a Siemens Advance Maxum via a Siemens Network Access Unit (NAU).</p> <hr/>
<b>MOLE ORDER</b>	<p>Click this button to display a dialog box on which you indicate the order in which the gas composition information comes into the S600+ via telemetry. <b>0</b> indicates any component which is <b>not</b> included in the Modbus map.</p> <p><b>Note:</b></p> <ul style="list-style-type: none"> <li>▪ The Modbus map you create must be compatible with the controller to which the S600+ is connected. Refer to <i>Chapter 14, Modbus Editor</i>, for further information.</li> <li>▪ This field displays <b>only</b> if you select <b>CHROMAT A</b> as the chromatograph configuration type.</li> <li>▪ This field is applicable <b>only</b> when selecting <b>Siemens</b> or <b>Generic</b> in the Type field.</li> </ul> <hr/>
<b>Address</b>	<p>Configures multi-drop chromatograph support. <b>Do not change unless advised to do so.</b></p> <p><b>Note:</b> This field displays <b>only</b> if you select <b>CHROMAT A</b> as the chromatograph configuration type.</p> <hr/>
<b>Stream</b>	<p>Sets the chromat analysis stream assigned to this metering stream. The default is <b>0</b>.</p> <p><b>Note:</b> This field displays <b>only</b> if you select <b>CHROMAT A</b> as the chromatograph configuration type. If you need to support more than one stream, contact Technical Support.</p> <hr/>

<b>Field</b>	<b>Description</b>
<b>Analysis Timeout</b>	<p>Sets the maximum number of seconds the S600+ waits to receive a new composition from the chromatograph controller before raising an alarm. The default is <b>900</b>.</p> <p><b>Note:</b> This field displays <b>only</b> if you select <b>CHROMAT A</b> as the chromatograph configuration type.</p>
<b>Download Timeout</b>	<p>Sets the maximum number of minutes the S600+ waits to receive a new composition from the supervisory computer before raising a <b>DL Timeout Alarm</b>. The default is <b>15</b>.</p> <p><b>Note:</b></p> <ul style="list-style-type: none"> <li>▪ A value of <b>0</b> disables the timeout.</li> <li>▪ This field displays <b>only</b> if you select <b>KP ONLY</b> in the Type field.</li> </ul>
<b>KEYPAD MOLES</b>	<p>Click to display a dialog box you use to define mole percentage values for each gas component.</p> <p><b>Note:</b> The system assumes the keypad composition adds to 100% (normalised) when the Acceptance Type is ACC/COPY. If you select <b>ACC/NORM</b> or <b>AUTO/NORM</b>, the system automatically normalises the keypad composition.</p>
<b>MOLE ADDITIONAL</b>	<p>Click to display a dialog box you use to define mole percentage values for gas components not analysed by the Danalyzer. The system assumes any additional components to be normalised values, so the analyser components are re-normalised to (100 – sum of additional components).</p> <p><b>Note:</b> This field displays <b>only</b> if you select <b>CHROMAT A</b> as the chromatograph configuration type.</p>
<b>USER MOLES</b>	<p>Click to display a dialog box you use to define mole percentage values for each gas component. The system assumes user moles to be normalised.</p> <p><b>Note:</b> The S600+ uses these values <b>only</b> if you set the Initial Mode to <b>USER</b>. A Modbus download from another computer may overwrite these values on a running configuration.</p>
<b>Check Limits</b>	<p>Enables limit checking on each gas component. When you select this check box, the <b>MOLE LO LIMITS</b> and <b>MOLE HI LIMITS</b> buttons display.</p>

Field	Description
<b>MOLE LO LIMITS</b>	<p>Click to display a dialog box you use to define low mole percentage limit values for each gas component. Enter <b>0</b> in any field to prevent the test for the selected component.</p> <p><b>Note:</b></p> <ul style="list-style-type: none"> <li>▪ The system uses the values you enter through these buttons <b>only</b> if you select the Check Limits check box. The system applies this test to the keypad, downloaded, user, additional, and new analysis components. When enabled, the system applies the limit check against the high and low limits. Limits are considered valid if the limit is greater than zero (0). The system also applies the check to the Total field. If you <b>disable</b> the limit check, the keypad, downloaded, and user Total field must lie within 0.1% and 150%. A sum of the new analysis must be within 99.5% and 100.5%.</li> <li>▪ This field displays <b>only</b> if you place a check mark in the Check Limits field.</li> </ul>
<b>MOLE HI LIMITS</b>	<p>Click to display a dialog box you use to define high mole percentage limit values for each gas component. Enter <b>0</b> in any field to prevent the test for the selected component.</p> <p><b>Note:</b> See note in description of Mole Lo Limits field.</p>
<b>Check Deviations</b>	<p>Enables checking on the deviation from the last good analysis for each component. When you select this check box, the <b>MOLE DEVN LIMITS</b> button displays.</p> <p><b>Note:</b> This field displays <b>only</b> if you select <b>CHROMAT A</b> as the chromatograph configuration type.</p>
<b>MOLE DEVN LIMITS</b>	<p>Displays a dialog box you use to define the maximum deviation allowed for each gas component. Enter <b>0</b> in any field to prevent the test for the selected component.</p> <p><b>Note:</b> This field displays <b>only</b> if you place a check mark in the Check Deviations field.</p>

3. Click in the hierarchy menu when you finish defining settings. A confirmation dialog box displays.
4. Click **Yes** to apply your changes. The PCSetup screen displays.

### 6.3.5 Gas Properties

Gas Properties settings define methods the system uses to calculate viscosity, isentropic exponent (also known as “specific heat ratio” or “adiabatic exponent”), and the velocity of sound.

These settings also allow you to define alarms. The system activates these alarms when the calculated results are not within the specified limits.

1. Select **Gas Properties** from the hierarchy menu. The Gas Properties screen displays.



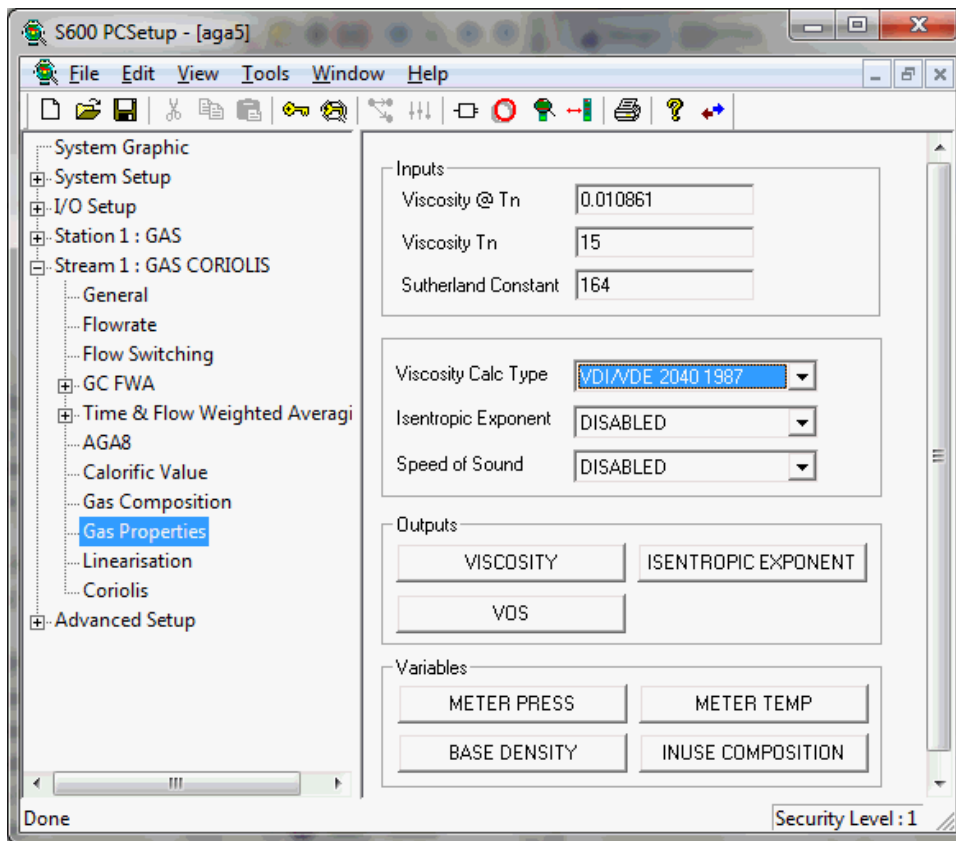

Figure 6-21. Gas Properties screen

2. Complete the following fields.

Field	Description
<b>Viscosity @ Tn</b>	Sets the reference viscosity for the gas. The default is <b>0.010861</b> . <b>Note:</b> Used <b>only</b> by VDI/VDE.
<b>Viscosity Tn</b>	Sets the reference viscosity temperature for the gas. The default is <b>15</b> . <b>Note:</b> Used <b>only</b> by VDI/VDE.
<b>Sutherland Constant</b>	Sets the Sutherland constant for the gas. The default is <b>164</b> (Methane). <b>Note:</b> Used <b>only</b> by VDI/VDE.
<b>Viscosity Calc Type</b>	Indicates the method for calculating the viscosity of the gas. Click ▼ to display all valid values.
<b>Disabled</b>	Value not calculated; defaults to keypad-entered value. This is the <b>default</b>
<b>SGERG GOST 30139-2015</b>	Uses calculations from GOST 30139-2015. Requires base density, N <sub>2</sub> , and CO <sub>2</sub> inputs.
<b>VDI/VDE 2040 1987</b>	Uses calculations from VDI/VDE 2040 Part 2 1987. Requires viscosity @T <sub>n</sub> , viscosity T <sub>n</sub> , and Sutherland Constant inputs.
<b>VNIC GOST 30319-2015</b>	Uses calculations from GOST 30319-2015. Requires full gas composition input.

Field	Description
<b>Isentropic Exponent</b>	Indicates the method for calculating the isentropic exponent of the gas. Click ▼ to display all valid values.
	<b>AGA10 2003</b> Uses calculations from AGA10 2003. Requires full gas composition input.
	<b>Disabled</b> Value not calculated; defaults to keypad-entered value. This is the <b>default</b> .
	<b>GRI 1991</b> Uses calculations from GRI 1991. Requires full gas composition input.
	<b>SGERG GOST 30139-2015</b> Uses calculations from GOST 30139-2015. Requires Base Density, N <sub>2</sub> and CO <sub>2</sub> inputs.
	<b>VNIC GOST 30319-2015</b> Uses calculations from GOST 30319-2015. Requires full gas composition input.
<b>Speed of Sound</b>	Indicates the method for calculating the speed of sound. Click ▼ to display all valid values.
	<b>AGA10 2003</b> Uses calculations from AGA10 2003. Requires full gas composition input.
	<b>Disabled</b> Value not calculated; defaults to keypad-entered value. This is the <b>default</b> .
	<b>GRI 1991</b> Uses calculations from GRI 1991. Requires full gas composition input.
	<b>SGERG GOST 30139-2015</b> Uses calculations from GOST 30139-2015. Requires Base Density, N <sub>2</sub> and CO <sub>2</sub> inputs.
	<b>VNIC GOST 30319-2015</b> Uses calculations from GOST 30319-2015. Requires full gas composition input.

3. Click any of the following buttons to display a dialog box you use to set gas property outputs or variables:

Button	Description
<b>VISCOSITY</b>	Click to display a Calculation Result dialog box you use to define the mode, keypad value, and the specific alarm limits for viscosity.
<b>ISENTROPIC EXPONENT</b>	Click to display a Calculation Result dialog box you use to define the mode, keypad value, and the specific alarm limits for the isentropic exponent.
<b>VOS</b>	Click to display a Calculation Result dialog box you use to define the mode, keypad value, and the specific alarm limits for the velocity of sound (VOS). <b>Note:</b> AGA10 refers to VOS as “speed of sound.”
<b>METER PRESS</b>	Click to display a Calculation Result dialog box you use to define the mode, keypad value, and the specific alarm limits for the meter pressure. <b>Note:</b> This button may be disabled on some applications.
<b>METER TEMP</b>	Click to display a Calculation Result dialog box you use to define the mode, keypad value, and the specific alarm limits for the meter temperature. <b>Note:</b> This button may be disabled on some applications.

Button	Description
<b>BASE DENSITY</b>	Click to display a Calculation Result dialog box you use to define the mode, keypad value, and the specific alarm limits for base density.
<b>INUSE COMPOSITION</b>	Click to display a <b>read-only</b> table of gas compositions. This corresponds to the table defined through the Gas Composition screen's <b>KEYPAD MOLES</b> button.

- Click in the hierarchy menu when you finish defining settings. A confirmation dialog box displays.
- Click **Yes** to apply your changes. The PCSetup screen displays.

### 6.3.6 Ethylene

This screen displays when you configure the S600+ to use the Ethylene standards to calculate base compressibility, base density, flowing compressibility and flowing density for ethylene. The S600+ also uses it to calculate the flowing compressibility and flowing density for Propylene.

The compressibility settings also allow you to define alarms. The system activates these when the calculated results are not within the specified limits.

- Select **Ethylene** from the hierarchy menu. The Ethylene screen displays.

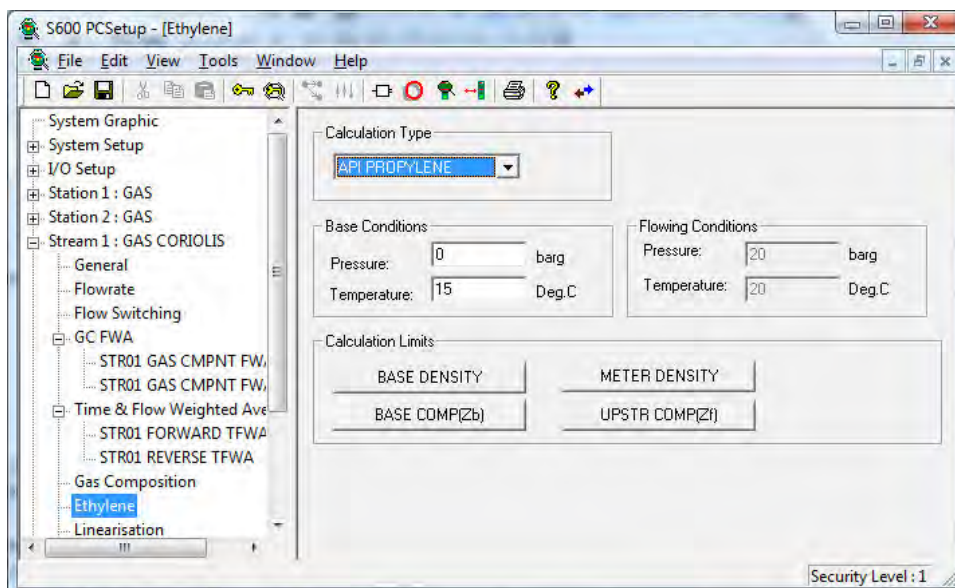

Figure 6-22. Ethylene screen

- Complete the following fields.

Field	Description
<b>Calculation Type</b>	Indicates the type of calculation to use. Click ▼ to display all valid values.
<b>IUPAC</b>	Uses IUPAC 1988 (Liquid and Gas Phase). This is the <b>default</b> .
<b>ETHYLENE</b>	Uses API 11.3.2.1 1985 (Gas Phase).
<b>API ETHYLENE</b>	Uses NBS 1045 1981 (Liquid and
<b>NBS 1045</b>	

Field	Description
	<b>ETHYLENE</b> Gas Phase)
	<b>API</b> Uses API 11.3.3.2 1974 (Liquid phase).
	<b>PROPYLENE</b>
<b>Pressure (Base Conditions)</b>	Sets the pressure under base conditions. The default is <b>0</b> .
<b>Temperature (Base Conditions)</b>	Sets the temperature under base conditions. The default is <b>15</b> .
<b>Pressure (Flowing Conditions)</b>	Sets the current flowing pressure to calculate compressibility and density. <b>Note:</b> On some streams this field may be <b>read-only</b> .
<b>Temperature (Flowing Conditions)</b>	Sets the current flowing temperature to calculate compressibility and density. <b>Note:</b> On some streams this field may be <b>read-only</b> .

- Click any of the following buttons to set calculation limits.

Button	Description
<b>BASE DENSITY</b>	Click to display a Calculation Result dialog box you use to define the mode, keypad value, and the specific alarm limits for the base density
<b>BASE COMP(Zb)</b>	Click to display a Calculation Result dialog box you use to define the mode, keypad value, and the specific alarm limits for the meter density.
<b>METER DENSITY</b>	Click to display a Calculation Result dialog box you use to define the mode, keypad value, and the specific alarm limits for the base compressibility.
<b>UPSTR COMP(Zf)</b>	Click to display a Calculation Result dialog box you use to define the mode, keypad value, and the specific alarm limits for the upstream (flowing) compressibility.

- Click in the hierarchy menu when you finish defining settings. A confirmation dialog box displays.
- Click **Yes** to apply your changes. The PCSetup screen displays.

### 6.3.7 Linearisation

Linearisation settings define the constants and calculation limits for the meter factor. The S600+ calculates a meter factor corresponding to the frequency by interpolating the frequency between fixed points and then cross-referencing the result against a lookup table. Linearisation settings also allow you to define alarms. The system activates these alarms when the calculated results for the Meter Factor are not within specified limits.

---

#### Notes:

- The linearisation curve for Gas Coriolis configurations uses frequency as the default input for Meter Factor calculations. The ability to change the default is available **only** with Config600 Pro software.
- Batching systems that employ meter factor linearisation with retrospective meter factor adjustments assume that the adjusted value has a “keypad” mode.

- To prevent the live metering system from applying a double correction, use **either** a calculated meter factor **or** a calculated K-factor linearisation (that is, only one factor should have a calculated mode).

1. Select **Linearisation** from the hierarchy menu. The Linearisation screen displays.

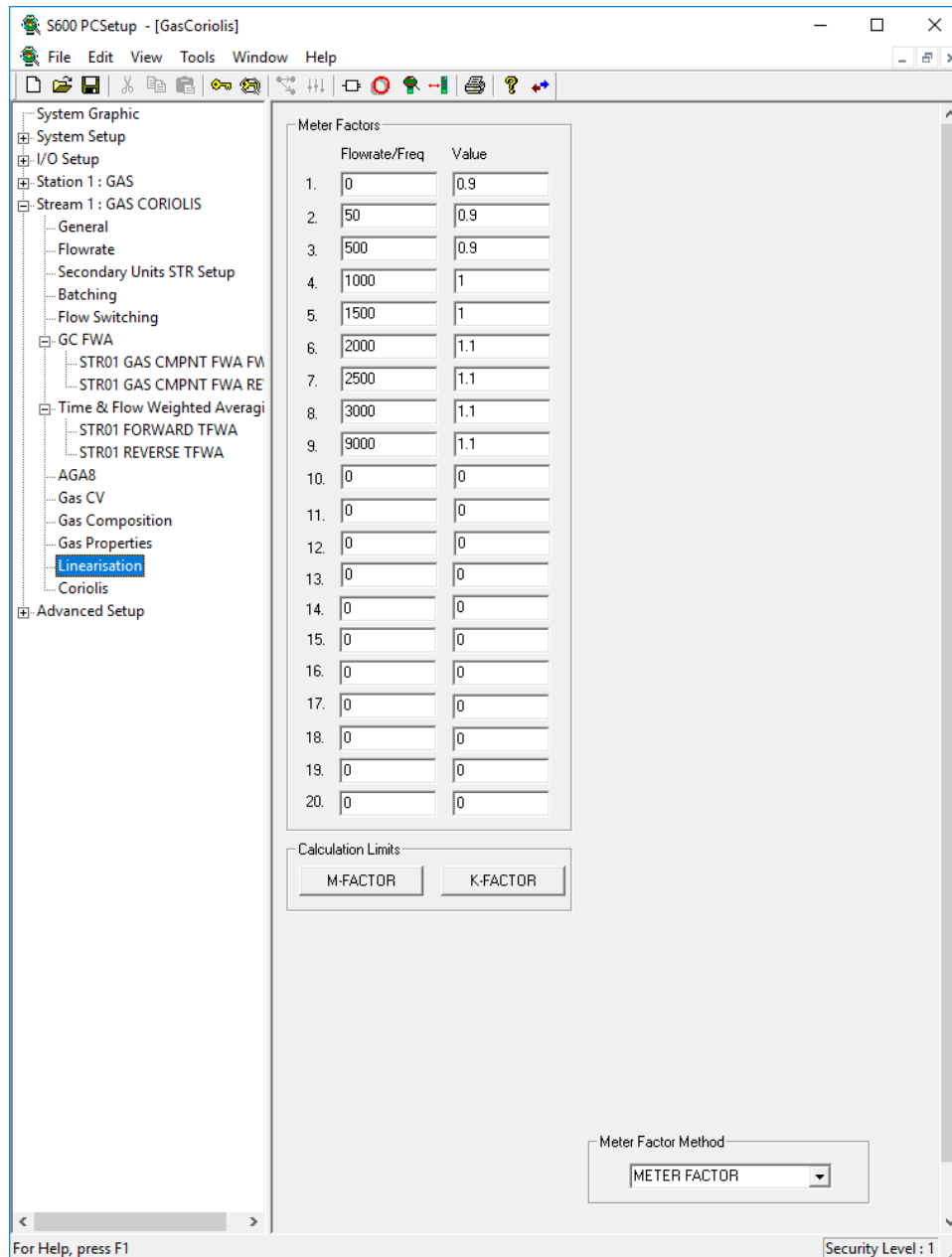

Figure 6-23. Linearisation screen

- Complete the following fields.

Field	Description
<b>Meter Factors</b>	Sets up to 20 flow rate and values for the meter correction factors.
	<b>Flowrate/Freq</b> Sets the flowrate and frequency for each of the meter correction factors.
	<b>Value</b> Sets the corresponding values for each of the meter correction factors.
<b>M-FACTOR</b>	Click to display a Calculation Result dialog box you use to define the mode, keypad value, and the specific alarm limits for the respective factor.
<b>K-FACTOR</b>	Click to display a Calculation Result dialog box you use to define the mode, keypad value, and the specific alarm limits for the respective factor.
<b>Meter Factor Method</b>	Selectable between METER FACTOR (values entered as normal) and ERROR PERCENT (Meter Factor entered as a percentage).

- Click in the hierarchy menu when you finish defining settings. A confirmation dialog box displays.
- Click **Yes** to apply your changes. The PCSetup screen displays.

### 6.3.8 Sampling

Sampling defines the method and interval period for sampling product from a flowing pipeline. By default, Config600 supports one sampler per stream. Config600 uses the following stages during the sampling process:

Stage	Description
<b>0</b>	Idle
<b>1</b>	Monitor
<b>2</b>	Digout n
<b>3</b>	Min Intvl
<b>4</b>	Post Pulse
<b>5</b>	Stopped Manually
<b>6</b>	Stopped Can Full
<b>7</b>	Stopped Low Flow
<b>8</b>	Initial Time
<b>9</b>	Check Flow Switch
<b>10</b>	Stopped Flow Switch
<b>11</b>	Stopped Press Switch
<b>12</b>	Stopped initialise
<b>13</b>	Can Switch Over

**Note:** Batch auto-resets the sampler at the start of the batch.

- Select **Sampling** from the hierarchy menu. The Sampling screen displays.

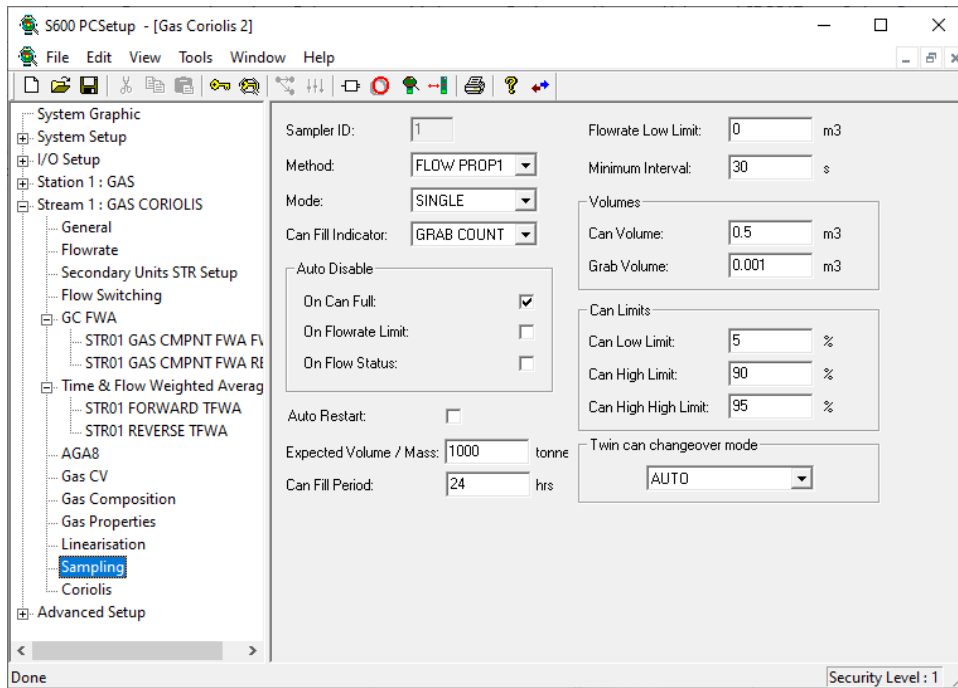

Figure 6-24. Stream Sampling screen

2. Complete the following fields.

Field	Description
<b>Sampler ID</b>	Provides an identifying label for the sampler. Each stream or station must have a unique sampler ID and must be greater than zero.
<b>Method</b>	Indicates the sampling method. Click ▼ to display all valid values.
<b>TIME PROP</b>	Divides the value in the Can Fill Period field by the number of grabs needed to fill the can (derived from the Can Volume and Fill Volume values) to determine a time interval per pulse. This is the <b>default</b> .
<b>FLOW PROP1</b>	Divides the value in the Volume field by the number of grabs needed to fill the can (derived from the Can Volume and Fill Volume values) to determine a volume throughput per pulse.
<b>FLOW PROP2</b>	Uses the value in the Volume field as the volume throughput per pulse.
<b>FLOW PROP3</b>	Uses the value in the Volume field as the volume throughput per pulse, but supports low pressure digital input and pump prime output.

Field	Description
<b>Mode</b>	Indicates the sampling mode. Click ▼ to display all valid values. The S600+ uses Can 1 or Can 2.
	<b>SINGLE</b> Acquire sample in one trial. This is the <b>default</b> .
	<b>DUAL</b> Acquire samples in two trials. <b>Note:</b> If you select <b>Dual</b> , the sampler switches to a second can when the current can is full (according to the two can switchover mode).
<b>Can Fill Indicator</b>	Indicates when the sampling can is full. Click ▼ to display all valid values.
	<b>GRAB COUNT</b> Uses the number of pulses output to the sampler to determine when the sample is full. This is the <b>default</b> .
	<b>DIG I/P</b> Uses a digital input to determine when the sampler is full.
	<b>ANALOG I/P</b> Uses an analog input to determine when the sampler is full.
<b>Auto Disable</b>	Indicates the event at which the system automatically disables the sampling process. Select the appropriate check box to identify the specific event.
	<b>On Can Full</b> Disables the sampling process when the can is full. This is the <b>default</b> .
	<b>On Flowrate Limit</b> Disables the sampling process when the flowrate is less than the value of the Flowrate Low Limit.
	<b>On Flow Status</b> Disables the sampling process when the flow status value is not on-line.
<b>Auto Restart</b>	Automatically restarts (if selected) sampling following an automatic disabling.
<b>Expected Volume/Mass</b>	Indicates, in cubic meters, the expected flow volume or mass of the sampling can. This is the value the Flow Prop1 and Flow Prop2 sampling methods use for calculations. The default is <b>1000</b> .
<b>Can Fill Period</b>	Sets, in hours, the time required to fill the sampling can. The default is <b>24</b> . <b>Note:</b> The Time Prop sampling method uses this value for its calculations.
<b>Flowrate Low Limit</b>	Indicates flowrate low limit used by the Auto Disable on Flowrate Limit option. The default is <b>0</b> . <b>Note:</b> This field is required if you select the On Flowrate Limit check box for Auto Disable.
<b>Minimum Interval</b>	Indicates, in seconds, the minimum amount of time between grabs. This is the value the Time Prop sampling method uses for its calculations. The default is <b>30</b> . <b>Note:</b> If the sample exceeds this limit, the system sets the overspeed alarm and increments the overspeed counter.



Field	Description
<b>Volumes</b>	<b>Can Volume</b> Indicates, in cubic meters, the volume of the sampling can. The default is <b>0.5</b> .
	<b>Grab Volume</b> Indicates, in cubic meters, the volume of the sampling grab. The default is <b>0.001</b> .
<b>Can Limits</b>	<b>Can Low Limit</b> Indicates the low alarm value as a percentage of the can volume. The default is <b>5</b> .
	<b>Can High Limit</b> Indicates the high alarm value as a percentage of the can volume. The default is <b>90</b> .
	<b>Can High High Limit</b> Indicates the high high alarm value as a percentage of the can volume. The default is <b>95</b> .
<b>Twin Can Changeover Mode</b>	Indicates the changeover method for twin can sampling. Click ▼ to display all valid values.
	<p><b>AUTO</b> The sampler automatically changes over to the second can when the first is full.</p> <p><b>MANUAL</b> The sampler pauses sampling when the first can is full and requires the operator to change the value of Can Selected before sampling continues on the second can.</p> <p><b>Note:</b></p> <ul style="list-style-type: none"> <li>▪ If sampling is stopped because both cans are full, the Twin Can Changeover Mode is set to MANUAL by the system. The user must set back to AUTO if required.</li> <li>▪ The display for Twin Can Changeover must be manually added to the displays.</li> </ul>

3. Click in the hierarchy menu when you finish defining settings. A confirmation dialog box displays.
4. Click **Yes** to apply your changes. The PCSetup screen displays.

### 6.3.9 Coriolis

Coriolis settings define the constants and calculation limits for a range of parameters, including stream input sources and modes of operation. The Coriolis settings also allow you to define alarms. The system activates these alarms when the calculated results are not within specified limits.

Flow data is received from a Coriolis meter via Modbus serial communications or a pulse input, or a combination of both. The S600+ generates its own totals incrementally from the comms or pulses.

1. Select **Coriolis** from the hierarchy menu. The Coriolis screen displays.

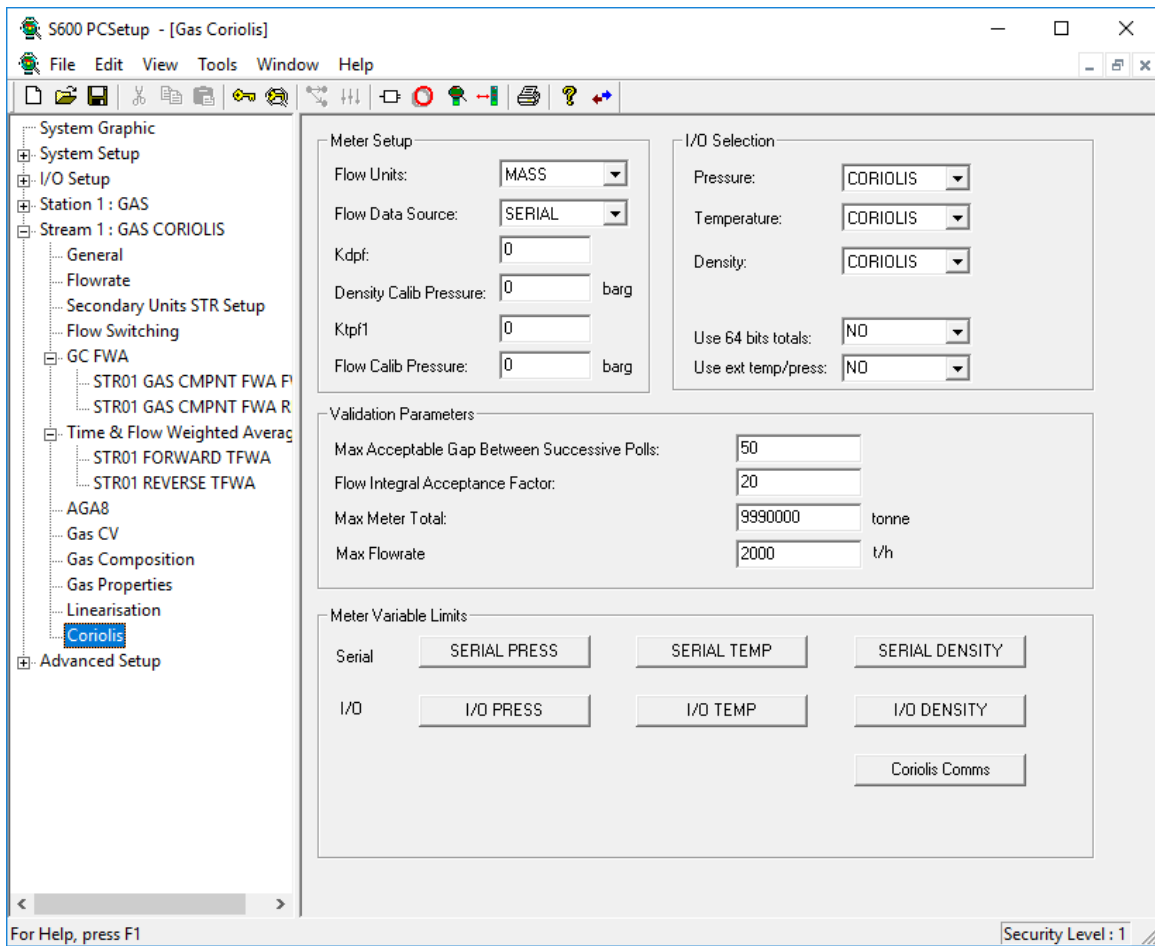

Figure 6-25. Coriolis screen

2. Complete the following fields.

Field	Description
<b>Flow Units</b>	Indicates the primary measurement for flow units. Click ▼ to display all valid values. Select <b>MASS</b> (configures the Coriolis meter for mass-based pulses) or <b>VOLUME</b> (configures the meter for volume-based pulses). The default is <b>MASS</b> .
<b>Flow Data Source</b>	Indicates the source of flow data. Click ▼ to display all valid values. Select <b>SERIAL</b> (enables the system to take the primary variable from the serial mass or volume flowrate) or <b>PULSE IP</b> (calculates the primary variable from the mass or volume pulse input). The default is <b>SERIAL</b> .
<b>Kdpf</b>	Sets a density correction factor value. The default is <b>0</b> . <b>Note:</b> Please contact your Coriolis supplier or reference the supplied calibration sheet for more information regarding this field and value.

Field	Description
<b>Density Calib Pressure</b>	<p>Sets a density calibration pressure value. The default is <b>0</b>.</p> <p><b>Note:</b> Please contact your Coriolis supplier or reference the supplied calibration sheet for more information regarding this field and value.</p>
<b>Ktpf1</b>	<p>Sets a pulse correction factor value. The default is <b>0</b>.</p> <p><b>Note:</b> Please contact your Coriolis supplier or reference the supplied calibration sheet for more information regarding this field and value.</p>
<b>Flow Calib Pressure</b>	<p>Sets a flow calibration pressure value. The default is <b>0</b>.</p> <p><b>Note:</b> Please contact your Coriolis supplier or reference the supplied calibration sheet for more information regarding this field and value.</p>
<b>Pressure</b>	<p>Indicates the source of pressure I/O. Click ▼ to display all valid values. Select <b>CORIOLIS</b> (use data from the Coriolis serial link) or <b>I/O</b> (use data either from the ADC/PRT/Density inputs [if correctly configured] or from the Coriolis serial link [if incorrectly configured]). The default is <b>CORIOLIS</b>.</p> <p><b>Note:</b> If you select <b>I/O</b>, remember to configure the analogue inputs.</p>
<b>Temperature</b>	<p>Indicates the source of temperature I/O. Click ▼ to display all valid values. Select <b>CORIOLIS</b> (use data from the Coriolis serial link) or <b>I/O</b> (uses data either from the ADC/PRT/Density inputs [if correctly configured] or from the Coriolis serial link [if incorrectly configured]). The default is <b>CORIOLIS</b>.</p> <p><b>Note:</b> If you select <b>I/O</b>, remember to configure the analogue inputs.</p>
<b>Density</b>	<p>Indicates the source of density I/O. Click ▼ to display all valid values. Select <b>CORIOLIS</b> (use data from the Coriolis serial link) or <b>I/O</b> (use data either from the ADC/PRT/Density inputs [if correctly configured] or from the Coriolis serial link [if incorrectly configured]). The default is <b>CORIOLIS</b>.</p> <p><b>Note:</b> If you select <b>I/O</b>, remember to configure the densitometer.</p>
<b>Use 64 bit totals</b>	<p>Indicates whether the S600+ uses the 64-bit totals received from the Coriolis meter in its totalisation routines.</p> <hr/> <p><b>NO</b> Use the 32-bit totals received from the Coriolis meter. This is the <b>default</b>.</p> <hr/> <p><b>YES</b> Use the 64-bit totals received from the Coriolis meter.</p>
<b>Use ext temp/press</b>	<p>Indicates which serial temperature and pressure values the S600+ uses in calculations.</p> <p><b>Note:</b> This is valid <b>only</b> if the temperature and pressure I/O selections are set to <b>CORIOLIS</b>.</p> <hr/> <p><b>NO</b> Use the internally derived temperature and pressure values. This is the <b>default</b>.</p> <hr/> <p><b>YES</b> Use the external temperature and pressure input values.</p>

Field	Description
<b>Max Acceptable Gap</b>	Sets, in seconds, the maximum acceptable gap between successive polls. The default is <b>50</b> . The system's incremental validation logic uses this value to determine communication failures.
<b>Flow Integral Acceptance Factor</b>	Sets the acceptance tolerance factor for comparing flowrate to elapsed totals. Used by the increment validation logic. The default is <b>20</b> .
<b>Max Meter Total</b>	Sets a maximum allowable increment in the received total. Used by the increment validation logic.
<b>Max Flowrate</b>	Sets a maximum allowable flowrate. Used by the increment validation logic. The default is <b>160</b> .

3. Click any of the following buttons to set meter variable limits:

Button	Description
<b>SERIAL PRESS</b>	Click to display a Calculation Result dialog box you use to define the mode, keypad value, and the specific alarm limits for serial pressure.
<b>SERIAL TEMP</b>	Click to display a Calculation Result dialog box you use to define the mode, keypad value, and the specific alarm limits for serial temperature.
<b>SERIAL DENSITY</b>	Click to display a Calculation Result dialog box you use to define the mode, keypad value, and the specific alarm limits for serial density.
<b>I/O PRESSURE</b>	Click to display an Analog Input dialog box you use to define various values for the analog input. For further information, refer to <i>Chapter 4, Section 4.3, Analog Inputs</i> .
<b>I/O TEMPERATURE</b>	Click to display an Analog Input dialog box you use to define various values for the analog input. For further information, refer to <i>Chapter 4, Section 4.3, Analog Inputs</i> .
<b>I/O DENSITY</b>	Click to display a Calculation Result dialog box you use to define the mode, keypad value, and the specific alarm limits for I/O density.
<b>Coriolis Comms</b>	Click to access the I/O Setup screen in Comms.

4. Click in the hierarchy menu when you finish defining settings. A confirmation dialog box displays.

5. Click **Yes** to apply your changes. The PCSetup screen displays.

**Coriolis Validation Logic**

The system supports logic to check whether the flowrate and totals values received across the serial link are in proportion and correspond to data received on the previous poll.

The expressions in upper case are keypad entered values. The default values are:

- MAX POLL GAP = 50 seconds
- FLOW INTEGRAL FACTOR = 20
- MAX FLOWRATE = 2000 t/h
- MAX INCREMENT = 9990000 tonne

The task runs approximately once per second, so delta\_t would normally be about 1 second.

```
proc validate_inc()
    valid = FALSE
```

```

delta_t = current time - previous time
increment = current total - previous total
flow_inc = (current fr + previous fr) / 2 * delta_t
if delta_t < MAX POLL GAP then
    if increment <= FLOW INTEGRAL FACTOR * flow_inc then
        if increment < MAX FLOWRATE * delta_t then
if increment < MAX INCREMENT then
            valid = TRUE
        endif
    endif
endif
endif
endif
return (valid)
endproc

```

### 6.3.10 Local Units

This option allows you to override the global K-factor unit, since a gas application may have more than one type of meter, each using different K-factor units.

1. Select **Local Units** from the hierarchy menu. The Local Units screen displays.

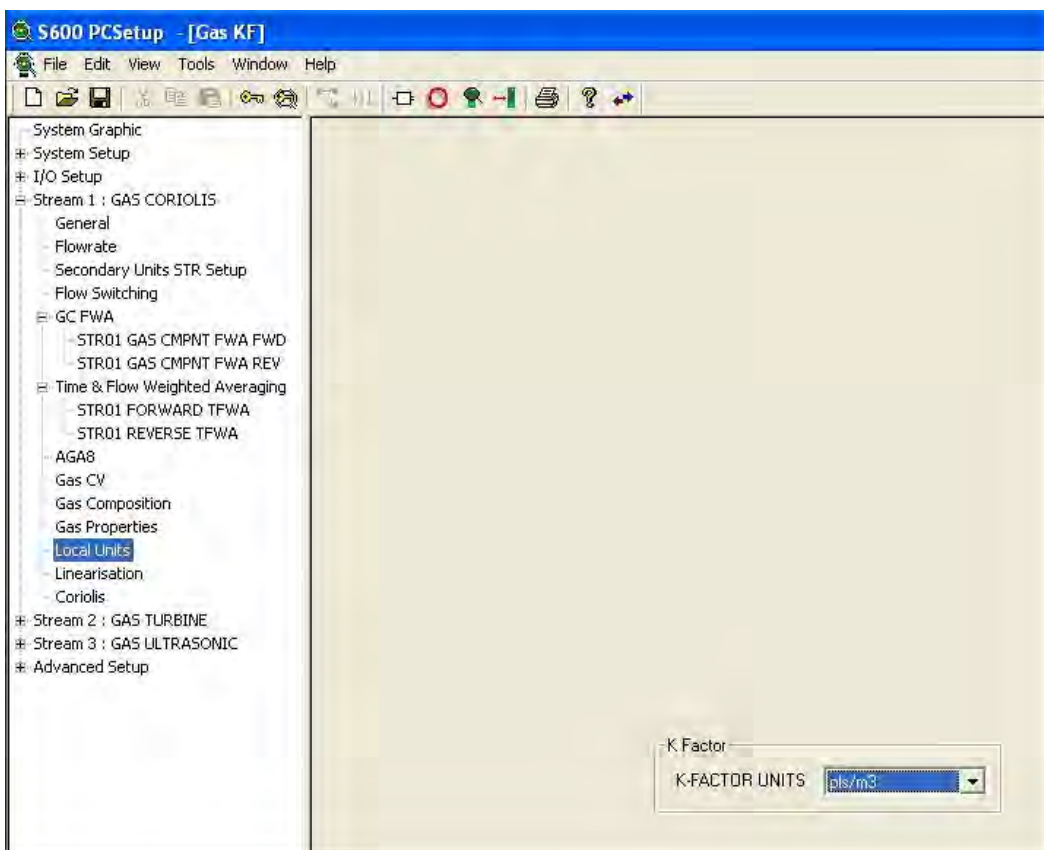

Figure 6-26. Local Units screen

2. Complete the following field:

Field	Description
<b>K-Factor Units</b>	Indicates the type of units to use and override the system K-factor units of measurement. Click ▼ to display all valid values. The default is <b>SYSTEM UNITS</b> . <b>Note:</b> If you select <b>System Units</b> , the stream uses

- | Field | Description               |
|-------|---------------------------|
|       | the global default value. |
3. Click in the hierarchy menu when you finish defining settings. A confirmation dialog box displays.
  4. Click **Yes** to apply your changes. The PCSetup screen displays.

## 6.4 Gas – DP

---

These stream settings are specific to gas applications using differential pressure (DP) meters. When you initially create a configuration, the calculation selections you make determine which calculation-specific screens appear in the hierarchy menu.



### Caution

**It is extremely unlikely that any one S600+ configuration would contain all the settings discussed in this section. For that reason, several sample configurations demonstrate the settings.**

---

### 6.4.1 Downstream/Upstream Correction

Downstream and Upstream correction settings define the parameters required to either correct upstream measurements to downstream measurements or correct downstream measurements to upstream measurements.

For gas, the system obtains pressure and density measurements from either downstream or upstream of the orifice plate. DP flow calculations require temperature, pressure, and density to be **upstream** values.

These correction settings also allow you to define alarms. The system activates these alarms when the calculated results are not within the specified limits.

1. Select **Downstream Upstream Correction** from the hierarchy menu for the desired stream.
2. Select **CORR T/P** (to correct temperature and pressure) or **CORR DENS** (to correct density). The system displays the Downstream/Upstream Correction screen.

---

**Note:** For the purpose of explanation, we include two figures (*Figure 6-27* and *Figure 6-28*) that display all options. Depending on your selections in the previous step, Config600 displays only portions of these screens.

---

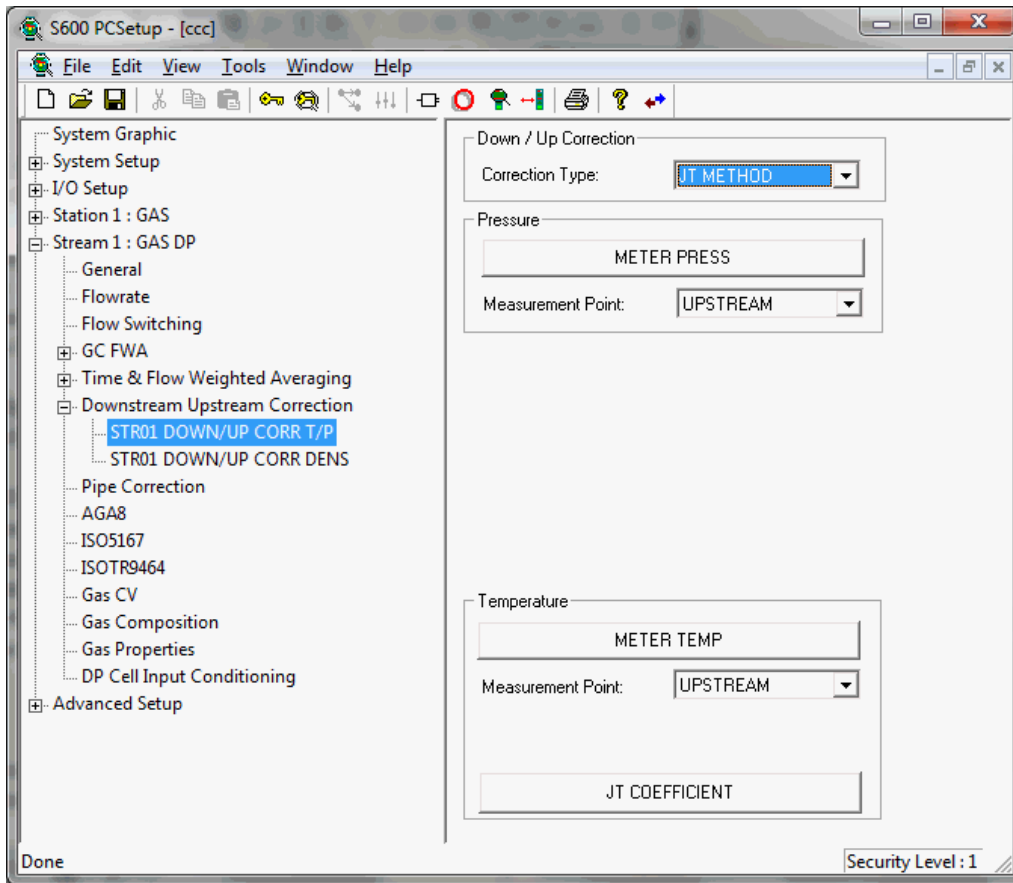

Figure 6-27. Temperature/Pressure Correction screen

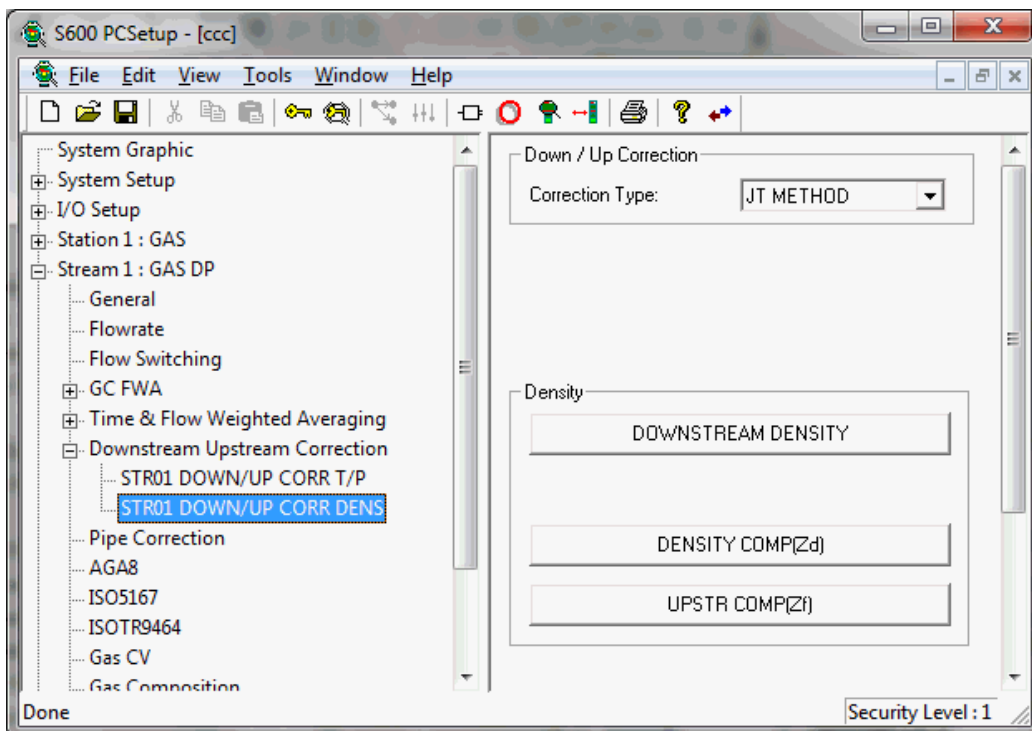

Figure 6-28. Density Correction screen

3. Click the appropriate button or complete the following fields.

<b>Field</b>	<b>Description</b>
<b>Correction Type</b>	Indicates the correction methodology the S600+ applies to temperature and density corrections. Click ▼ to display all valid values.
	<b>SIMPLE</b> Up stream and downstream temperatures are the same.
	<b>EXTENDED</b> Calculates upstream temperature from measured downstream temperature and upstream density from measured downstream density. Calculation uses exponents calculated from the isentropic exponent. This is the <b>default</b> .
	<b>JT METHOD</b> Calculates upstream temperature from measured downstream temperature using the Joule-Thomson coefficient as described in ISO5167-2003. <b>Note:</b> This selection adds the JT Coefficient button to the screen.
<b>METER PRESS</b>	Click to display an Analog Input dialog box you use to define various values for the analog input.
<b>Measurement Point (Pressure)</b>	Indicates the source of flow data for pressure calculations. Click ▼ to display all valid values. The default is <b>UPSTREAM</b> .
	<b>Note:</b> This represents the physical measurement point on the metering system.
<b>DOWNSTREAM DENSITY</b>	Click to display a Calculation Result dialog box you use to define the mode, keypad value, and the specific alarm limits for downstream density. <b>Note:</b> This button displays <b>only</b> if you select the <b>CORR DENS</b> component.
<b>DENS EXP CONSTANT</b>	Click to display a Calculation Result dialog box you use to define the mode, keypad value, and the specific alarm limits for density expansion. <b>Note:</b> This button displays <b>only</b> if you select the <b>CORR DENS</b> component.
<b>DENSITY COMP(Zd)</b>	Click to display a Calculation Result dialog box you use to define the mode, keypad value, and the specific alarm limits for densitometer compressibility (Zd).
<b>UPSTR COMP(Zf)</b>	Click to display a Calculation Result dialog box you use to define the mode, keypad value, and the specific alarm limits for upstream compressibility (Zf) at upstream conditions.
<b>METER TEMP</b>	Click to display an Analog Input dialog box you use to define various values for the analog input.
<b>Measurement Point (Temperature)</b>	Indicates the source of flow data for temperature calculations. Click ▼ to display all valid values. The default is <b>DOWNSTREAM</b> .
	<b>Note:</b> This field, which represents the physical measurement point on the metering system, displays <b>only</b> if you select <b>EXTENDED</b> as a Correction Type.



Field	Description
<b>TEMP EXP CONSTANT</b>	Click to display a Calculation Result dialog box you use to define the mode, keypad value, and the specific alarm limits for temperature expansion. <b>Note:</b> This button displays <b>only</b> if you select <b>EXTENDED</b> as a Correction Type.
<b>JT COEFFICIENT</b>	Displays a Calculation Result dialog box you use to define the mode, keypad value, and the specific alarm limits for density expansion. <b>Note:</b> This button displays <b>only</b> if you select <b>JT COEFFICIENT</b> as a Correction Type.

4. Click in the hierarchy menu when you finish defining settings. A confirmation dialog box displays.
5. Click **Yes** to apply your changes. The PCSetup screen displays.

### 6.4.2 Pipe Correction

Pipe Correction settings define the calibrated diameter, temperature, and materials of manufacture for the pipe and orifice plate. Use these settings to correct the calibrated pipe and orifice diameters to line conditions.

The pipe correction settings also allow you to define alarms. The system activates these alarms when the calculated results are not within the specified limits.

1. Select **Pipe Correction** from the hierarchy menu. The system displays the Pipe Correction screen.

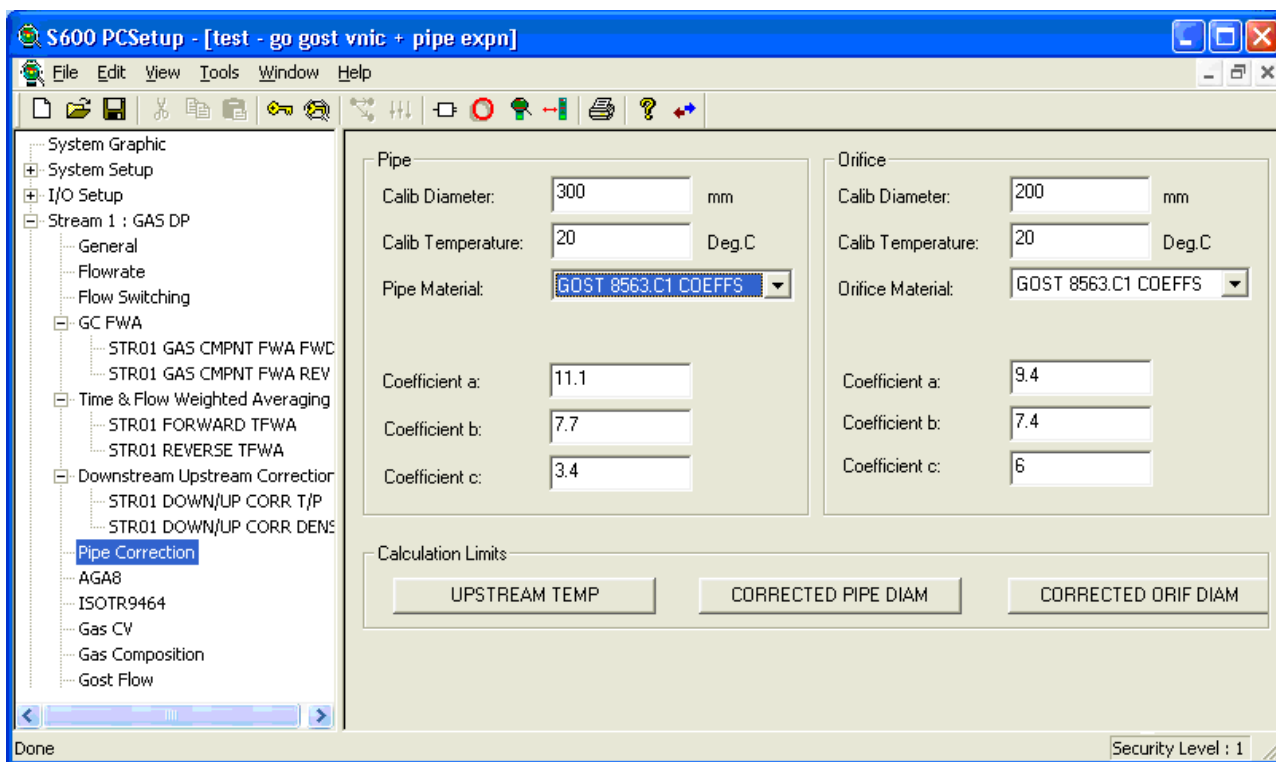

Figure 6-29. Pipe Correction screen

2. Complete the following fields.

Field	Description
<b>Pipe</b>	
<b>Calib Diameter</b>	Sets, in mm, the calibrated diameter of the pipe. The default is <b>300</b> .
<b>Calib Temperature</b>	Sets, in Deg C., the calibrated temperature of the pipe. The default is <b>20</b> .
<b>Pipe Material</b>	Identifies the material for the pipe. Click ▼ to display all valid values.
<b>STAINLESS</b>	Uses a value of either 0.00000925 in/in°F or 0.0000167 mm/mm°C. This is the standard expansion coefficient for a US application using Imperial or metric units. This is the <b>default</b> .
<b>MONEL</b>	Uses a value of either 0.00000795 in/in°F or 0.0000143 mm/mm°C. This is the standard expansion coefficient for a US application using Imperial or metric units.
<b>CARBON ST</b>	Uses a value of either 0.00000620 in/in°F or 0.0000112 mm/mm°C. This is the standard expansion coefficient for a US application using Imperial or metric units.
<b>USER</b>	Uses the coefficient value entered in the User Exp Coeff field.
<b>GOST 8563.C1 COEFFS</b>	Calculates the expansion coefficient from additional coefficients in GOST 8.563.1 (Table C.1). <b>Note:</b> The GOST option displays only if you select <b>GOST1</b> or <b>GOST2</b> from PCSetup.
<b>304/316 Stainless</b>	Uses a value of either 0.00000925 in/in°F or 0.0000167 mm/mm°C. This is the standard expansion coefficient for a US application using Imperial or metric units.
<b>304 Stainless</b>	Uses a value of either 0.00000961 in/in°F or 0.0000173 mm/mm°C. This is the standard expansion coefficient for a US application using Imperial or metric units.
<b>316 Stainless</b>	Uses a value of either 0.00000889 in/in°F or 0.0000160 mm/mm°C. This is the standard expansion coefficient for a US application using Imperial or metric units.
<b>Monel 400</b>	Uses a value of either 0.00000772 in/in°F or 0.0000139 mm/mm°C. This is the standard expansion coefficient for a US application using Imperial or metric units.
<b>User Exp Coeff</b>	Sets a specific expansion coefficient the S600+ uses for the pipe correction. <b>Note:</b> This field displays <b>only</b> if you select <b>USER</b> for Pipe Material.

Field	Description
<b>Coefficient a, b, c</b>	Sets the specific coefficients the S600+ uses for the orifice expansion correction. <b>Note:</b> These fields display <b>only</b> if you select <b>GOST 8563.C1 COEFFS</b> for Pipe Material, which supplies its own algorithm and coefficients to calculate the pipe and orifice material expansion coefficients.
<b>Orifice</b>	
<b>Calib Diameter</b>	Sets, in mm, the calibrated diameter of the orifice. The default is <b>200</b> .
<b>Calib Temperature</b>	Sets, in Deg C., the calibrated temperature of the orifice. The default is <b>15</b> .
<b>Orifice Material</b>	Identifies the material for the orifice. Click ▼ to display all valid values.
<b>STAINLESS</b>	Uses a value of either 0.00000925 in/in°F or 0.0000167 mm/mm°C. This is the standard expansion coefficient for a US application using Imperial or metric units. This is the <b>default</b> .
<b>MONEL</b>	Uses a value of either 0.00000795 in/in°F or 0.0000143 mm/mm°C. This is the standard expansion coefficient for a US application using Imperial or metric units.
<b>CARBON ST</b>	Uses a value of either 0.00000620 in/in°F or 0.0000112 mm/mm°C. This is the standard expansion coefficient for a US application using Imperial or metric units.
<b>USER</b>	Uses the coefficient value entered in the User Exp Coeff field.
<b>GOST 8563.C1 COEFFS</b>	Calculates the expansion coefficient from additional coefficients in GOST 8.563.1 (Table C.1). <b>Note:</b> The GOST option displays only if you select <b>GOST1</b> or <b>GOST2</b> from PCSetup.
<b>304/316 Stainless</b>	Uses a value of either 0.00000925 in/in°F or 0.0000167 mm/mm°C. This is the standard expansion coefficient for a US application using Imperial or metric units.
<b>304 Stainless</b>	Uses a value of either 0.00000961 in/in°F or 0.0000173 mm/m°C. This is the standard expansion coefficient for a US application using Imperial or metric units.
<b>316 Stainless</b>	Uses a value of either 0.00000889 in/in°F or 0.0000160 mm/mm°C. This is the standard expansion coefficient for a US application using Imperial or metric units.
<b>Monel 400</b>	Uses a value of either 0.00000772 in/in°F or 0.0000139 mm/mm°C. This is the standard expansion coefficient for a US application using Imperial or metric units.

Field	Description
<b>User Exp Coeff</b>	Sets a specific expansion coefficient the S600+ uses for the orifice correction. The default is <b>1.6e-005</b> . <b>Note:</b> This field displays <b>only</b> if you select <b>USER</b> for Pipe Material.
<b>Coefficient a, b, c</b>	Sets the specific coefficients the S600+ uses for the orifice expansion correction. <b>Note:</b> These fields display <b>only</b> if you select <b>GOST 8563.C1 COEFFS</b> for Pipe Material, which supplies its own algorithm and coefficients to calculate the pipe and orifice material expansion coefficients.

---

**Note:** GOST applications refer to stainless steel as **12X17**, to monel as **12X18H9T**, and to carbon steel as **20**. The correction constants are taken from GOST 8.563.1.

---

- Click any of the following buttons to set calculation limits.

Button	Description
<b>UPSTREAM TEMP</b>	Click to display a Calculation Result dialog box you use to define the mode, keypad value, and the specific alarm limits for the upstream temperature.
<b>CORRECTED PIPE DIAM</b>	Click to display a Calculation Result dialog box you use to define the mode, keypad value, and the specific alarm limits for the corrected pipe diameter.
<b>CORRECTED ORIF DIAM</b>	Click to display a Calculation Result dialog box you use to define the mode, keypad value, and the specific alarm limits for the corrected orifice diameter.

- Click in the hierarchy menu when you finish defining settings. A confirmation dialog box displays.
- Click **Yes** to apply your changes. The PCSetup screen displays.

### 6.4.3 AGA8 (Compressibility)

Compressibility settings define the constants and calculation limits for a range of parameters including pressure, temperature, density, and compressibility factors. This screen displays when you configure the S600+ to use the main AGA8 standard to calculate base compressibility, standard compressibility, and flowing compressibility for natural gases.

---

**Note:** “Standard conditions” are assumed as 14.73 psia and 60° F.

---

The compressibility settings also allow you to define alarms. The system activates these alarms when the calculated results are not within the specified limits.

- Select **AGA8** from the hierarchy menu. The AGA8 screen displays.

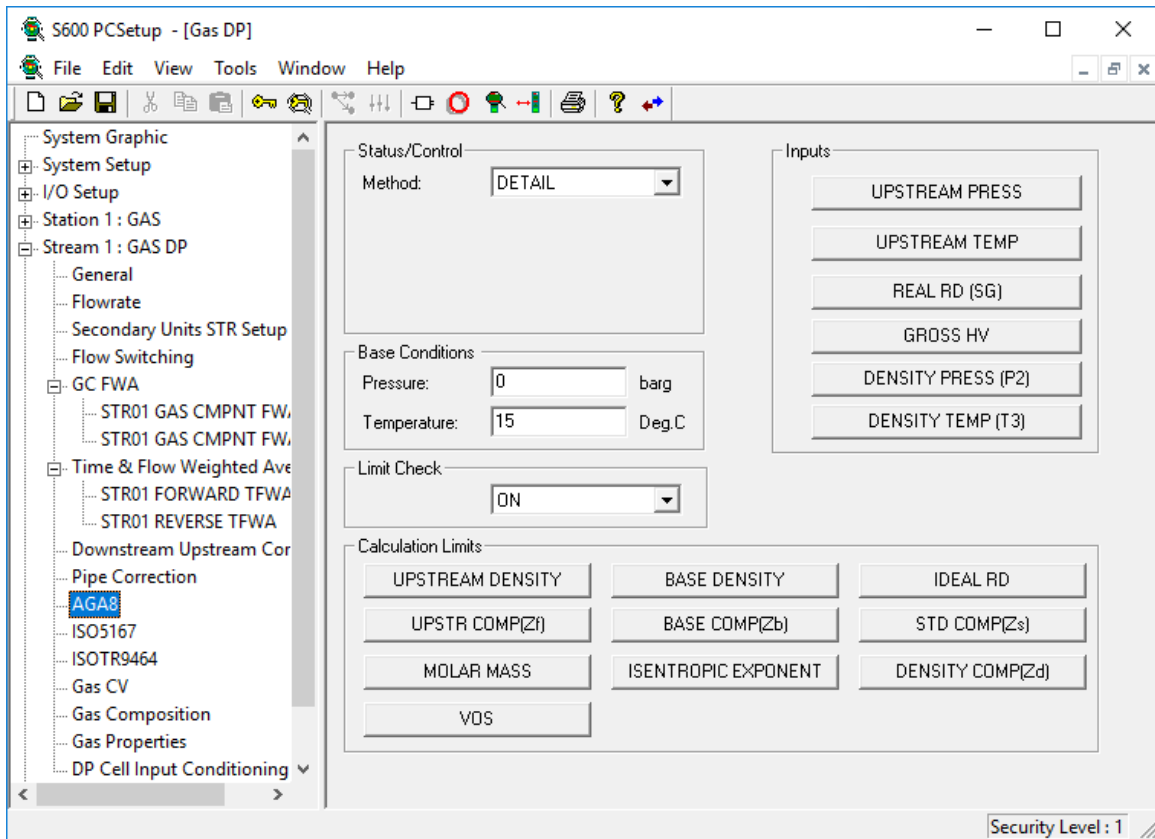

Figure 6-30. AGA8 (Compressibility) screen

2. Complete the following fields.

Field	Description
<b>Method</b>	Indicates the compressibility method. Click ▼ to display all valid values.
<b>DETAIL</b>	Uses 21 component values, temperature and pressure in accordance with the 1994 standard. This is the <b>default</b> .
<b>GROSS1</b>	Uses SG, Heating Value, CO <sub>2</sub> , temperature and pressure in accordance with the 1991 standard. <b>Note:</b> Gross1 only supports volumetric heating value and does not support mass heating value.
<b>GROSS2</b>	Uses SG, N <sub>2</sub> , CO <sub>2</sub> , temperature and pressure in accordance with the 1991 standard.
<b>VNIC</b>	Uses 20 component values, temperature and pressure in accordance with GOST 30319 1996.
<b>MGERG</b>	Uses 19 component values (As indicated in GERG Technical Monograph 2 1998) to calculate compressibility of natural gas mixtures based on a full compositional analysis.
<b>PT 1 DETAIL 2017</b>	Uses 21 component values, temperature and pressure in accordance with the 2017 standard.

Field	Description
<b>PT 1 GROSS1 2017</b>	Uses SG, Heating Value, CO <sub>2</sub> , temperature and pressure in accordance with the 2017 standard. <b>Note:</b> Gross1 only supports volumetric heating value and does not support mass heating value.
<b>PT 1 GROSS2 2017</b>	Uses SG, N <sub>2</sub> , CO <sub>2</sub> , temperature and pressure in accordance with the 2017 standard.
<b>PT 1 GROSS0 2017</b>	Uses 21 component values, temperature and pressure in accordance with the 2017 standard.
<b>PT 2 GERG 2008</b>	Uses 21 component values [as indicated in Table 1 AGA8 2017 Part 2 (GERG 2008)] to calculate compressibility of natural gas mixtures based on a full compositional analysis.
<b>Pressure</b>	Sets the pressure at base conditions. The default is <b>0</b> .
<b>Temperature</b>	Sets the temperature at base conditions. The default is <b>15</b> .
<b>Limit Check</b>	Overrides the system's calculation limit checking. Click ▼ to select <b>Off</b> and disable limit checking. The <b>default is On</b> . <b>Note:</b> Compressibilities and densities are less accurate and the calculation may fail completely when operating outside the calculation limits.
<b>UPSTREAM PRESS</b>	Click to display a Calculation Result dialog box you use to define the mode, keypad value, and the specific alarm limits for upstream pressure.
<b>UPSTREAM TEMP</b>	Click to display a Calculation Result dialog box you use to define the mode, keypad value, and the specific alarm limits for upstream temperature.
<b>REAL RD (SG)</b>	Click to display a Calculation Result dialog box you use to define the mode, keypad value, and the specific alarm limits for real relative density.
<b>GROSS HV</b>	Click to display a Calculation Result dialog box you use to define the mode, keypad value, and the specific alarm limits for gross heating value (HV).
<b>DENSITY PRESS (P2)</b>	Click to display a Calculation Result dialog box you use to define the mode, keypad value, and the specific alarm limits for density pressure (P2).
<b>DENSITY TEMP (T3)</b>	Click to display a Calculation Result dialog box you use to define the mode, keypad value, and the specific alarm limits for density temperature (T3).

- Click one or more of the following buttons to define AGA8 calculation limits.

Button	Description
<b>UPSTREAM DENSITY</b>	Click to display a Calculation Result dialog box you use to define the mode, keypad value, and the specific alarm limits for upstream density.
<b>UPSTR COMP(Zf)</b>	Click to display a Calculation Result dialog box you use to define the mode, keypad value, and the specific alarm limits for upstream compressibility (Zf).

Button	Description
<b>MOLAR MASS</b>	Click to display a Calculation Result dialog box you use to define the mode, keypad value, and the specific alarm limits for molar mass.
<b>VOS</b>	Click to display a Calculation Result dialog box you use to define the mode, keypad value, and the specific alarm limits for the velocity of sound. <b>Note:</b> This field is visible <b>only</b> if you select either <b>PT1 DETAIL 2017</b> or <b>PT2 GERG 2008</b> in the <b>Status/Control Method</b> field.
<b>BASE DENSITY</b>	Click to display a Calculation Result dialog box you use to define the mode, keypad value, and the specific alarm limits for the base density.
<b>BASE COMP(Zb)</b>	Click to display a Calculation Result dialog box you use to define the mode, keypad value, and the specific alarm limits for the base compressibility.
<b>ISENTROPIC EXPONENT</b>	Click to display a Calculation Result dialog box you use to define the mode, keypad value, and the specific alarm limits for the isentropic exponent. <b>Note:</b> This field is visible <b>only</b> if you select either <b>PT1 DETAIL 2017</b> or <b>PT2 GERG 2008</b> in the <b>Status/Control Method</b> field.
<b>IDEAL RD</b>	Click to display a Calculation Result dialog box you use to define the mode, keypad value, and the specific alarm limits for ideal relative density.
<b>STD COMP(Zs)</b>	Click to display a Calculation Result dialog box you use to define the mode, keypad value, and the specific alarm limits for standard compressibility (Zs).
<b>DENSITY COMP (Zd)</b>	Click to display a Calculation Result dialog box you use to define the mode, keypad value, and the specific alarm limits for the densitometer compressibility.

4. Click in the hierarchy menu when you finish defining settings. A confirmation dialog box displays.
5. Click **Yes** to apply your changes. The PCSetup screen displays.

#### 6.4.4 ISO5167 (Mass Flowrate)

ISO5167 mass settings define the constants and calculation limits for a range of parameters including pressure, density, flow coefficient, and pressure loss. This screen displays when you configure the S600+ to use the ISO5167 standard to calculate gas flow through the orifice meter.

Mass flowrate settings also allow you to define alarms. The system activates these alarms when the calculated results are not within the specified limits.

1. Select **ISO5167** from the hierarchy menu. The ISO5167 screen displays.

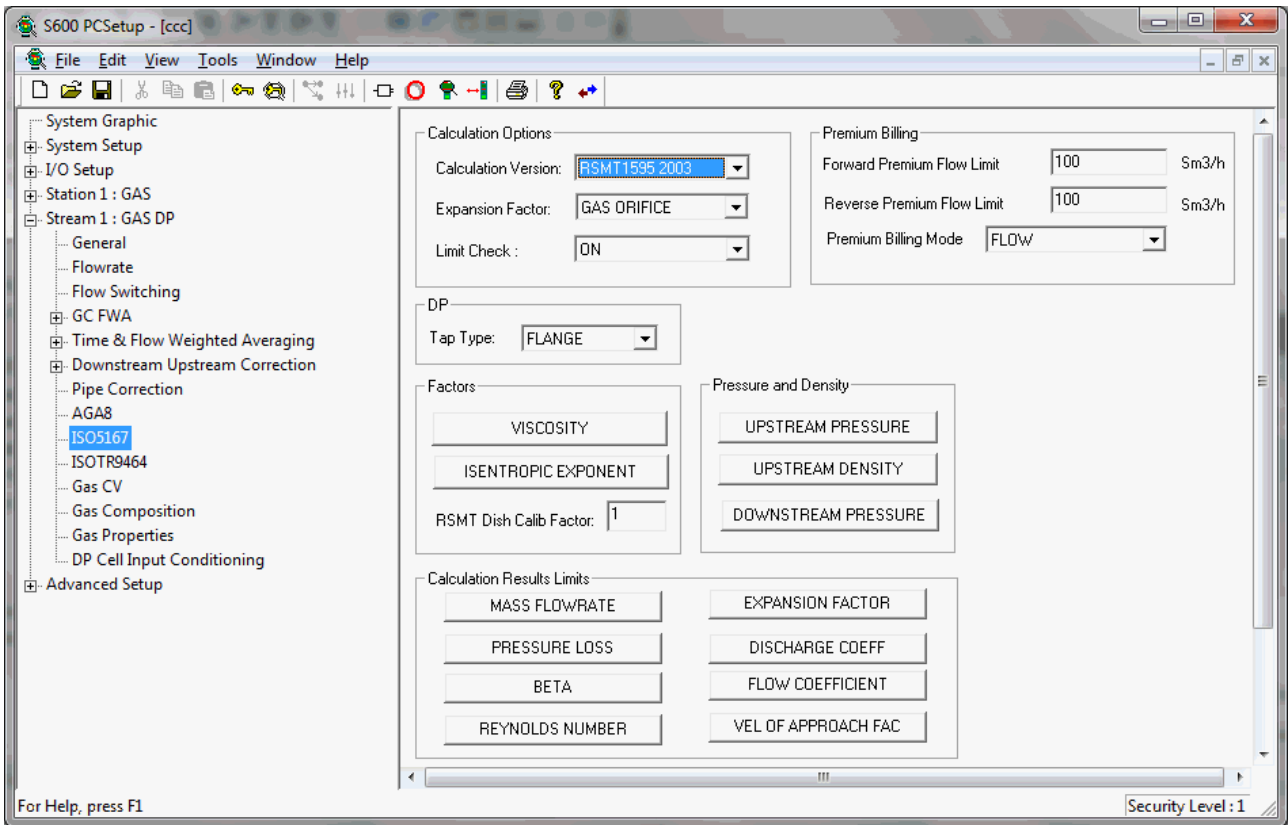

Figure 6-31. ISO5167 (Mass Flowrate) screen

2. Complete the following fields.

Field	Description				
<b>Calculation Version</b>	Indicates the specific version of the ISO5167 calculation. Click ▼ to display all valid versions. The default is <b>1991</b> .				
<b>Expansion Factor</b>	Displays options for calculating the fluid expansion factor. Click ▼ to display all valid versions. <table border="0" style="width: 100%; margin-top: 5px;"> <tr> <td style="width: 150px;"><b>GAS ORIFICE</b></td> <td>Use the expansion factor formula as defined by calculation you select in the <b>Calculation Version</b> field. This is the <b>default</b>.</td> </tr> <tr> <td><b>LIQUID ORIFICE</b></td> <td>Use an Expansion Factor = 1.0 (no expansion).</td> </tr> </table>	<b>GAS ORIFICE</b>	Use the expansion factor formula as defined by calculation you select in the <b>Calculation Version</b> field. This is the <b>default</b> .	<b>LIQUID ORIFICE</b>	Use an Expansion Factor = 1.0 (no expansion).
<b>GAS ORIFICE</b>	Use the expansion factor formula as defined by calculation you select in the <b>Calculation Version</b> field. This is the <b>default</b> .				
<b>LIQUID ORIFICE</b>	Use an Expansion Factor = 1.0 (no expansion).				
<b>Limit Check</b>	Overrides the system's calculation limit checking. Click ▼ to select <b>Off</b> and disable limit checking. The <b>default</b> is <b>On</b> . <p><b>Note:</b> If you enable limit checking, ISO5167 validates the calculation inputs and outputs in accordance with the following sections:</p> <ul style="list-style-type: none"> <li>▪ All tap types</li> <li>▪ Corner and D-D/2 taps</li> <li>▪ Flange taps</li> <li>▪ SA 1932 nozzles</li> <li>▪ Long radius nozzles</li> <li>▪ Venturi</li> <li>▪ Pressure taps</li> </ul>				



<b>Field</b>	<b>Description</b>
<b>Forward Premium Flow Limit</b>	In Premium Billing FLOW mode and Flow Direction FORWARD, sets a flowrate limit above which the system increments forward premium totals whenever the flowrate exceeds the keypad limit. In Premium Billing TOTAL mode and Flow Direction FORWARD, sets a total limit above which the system increments forward premium totals whenever the period total exceeds the keypad limit. The default is <b>100</b> .
<b>Reverse Premium Flow Limit</b>	In Premium Billing FLOW mode and Flow Direction REVERSE, sets a flowrate limit above which the system increments reverse premium totals whenever the flowrate exceeds the keypad limit. In Premium Billing TOTAL mode and Flow Direction REVERSE, sets a total limit above which the system increments reverse premium totals whenever the period total exceeds the keypad limit. The default is <b>100</b> .
<b>Premium Billing Mode</b>	Indicates the premium total mode, in which the system increments premium totals at the end of a period only if the period total exceeds the keypad limit. Click ▼ to display all valid values. The default is <b>FLOW</b> .
<b>Tap Type</b>	Click ▼ to indicate the position of the differential pressure tap on the metering assembly. Possible options are FLANGE, CORNER, D-D/2, NOZZ 1932, NOZZ LR, VENT TUBE, VENT NOZZ. The default is <b>FLANGE</b> .
<b>VISCOSITY</b>	Click to display a Calculation Result dialog box you use to define the mode, keypad value, and the specific alarm limits for viscosity.
<b>ISENTROPIC EXPONENT</b>	Click to display a Calculation Result dialog box you use to define the mode, keypad value, and the specific alarm limits for the isentropic exponent.
<b>RSMT Dish Calib Factor</b>	Sets the discharge coefficient calibration factor for the Rosemount 1595 conditioning orifice plate. <b>Note:</b> This field displays <b>only</b> if you select <b>RSMT1595 2003</b> as the Calculation Version.
<b>UPSTREAM PRESSURE</b>	Click to display a Calculation Result dialog box you use to define the mode, keypad value, and the specific alarm limits for upstream pressure.
<b>UPSTREAM DENSITY</b>	Click to display a Calculation Result dialog box you use to define the mode, keypad value, and the specific alarm limits for upstream density.
<b>DOWNSTREAM PRESSURE</b>	Click to display a Calculation Result dialog box you use to define the mode, keypad value, and the specific alarm limits for downstream pressure.

- Click any of the following buttons to define ISO5167 calculation result limits.

<b>Button</b>	<b>Description</b>
<b>MASS FLOWRATE</b>	Click to display a Calculation Result dialog box you use to define the specific alarm limits for mass flowrate.
<b>PRESSURE LOSS</b>	Click to display a Calculation Result dialog box you use to define the mode, keypad value, and the specific alarm limits for pressure loss.

Button	Description
<b>BETA</b>	Click to display a Calculation Result dialog box you use to define the specific alarm limits for the calculated diameter ratio.
<b>REYNOLDS NUMBER</b>	Click to display a Calculation Result dialog box you use to define the specific alarm limits for the Reynolds number.
<b>EXPANSION FACTOR</b>	Click to display a Calculation Result dialog box you use to define the mode, keypad value, and the specific alarm limits for the expansion factor.
<b>DISCHARGE COEFF</b>	Click to display a Calculation Result dialog box you use to define the specific alarm limits for the discharge coefficient.
<b>FLOW COEFFICIENT</b>	Click to display a Calculation Result dialog box you use to define the mode, keypad value, and the specific alarm limits for the flow coefficient.
<b>VEL OF APPROACH FAC</b>	Click to display a Calculation Result dialog box you use to define the specific alarm limits for the velocity of approach coefficient.

- For wet gas, complete the following values.

Field	Description								
<b>Calc Type</b>	Click ▼ to set the specific type of wet gas calculation the S600+ uses. Possible options are: <table border="1" style="width: 100%; border-collapse: collapse;"> <tbody> <tr> <td style="width: 15%;"><b>MURDOCK</b></td> <td>Uses Lockhart-Martinelli parameter. This is the <b>default</b>.</td> </tr> <tr> <td><b>CHISHOLM</b></td> <td>Uses Lockhart-Martinelli parameter + Gas to Liquid Density Ratio.</td> </tr> <tr> <td><b>DE-LEEUEW</b></td> <td>Uses Lockhart-Martinelli parameter + Gas to Liquid Density Ratio + Gas Froude Number (de Leeuw correlation).</td> </tr> <tr> <td><b>STEVEN</b></td> <td>Uses Lockhart-Martinelli parameter + Gas to Liquid Density Ratio + Gas Froude Number (Steven correlation).</td> </tr> </tbody> </table>	<b>MURDOCK</b>	Uses Lockhart-Martinelli parameter. This is the <b>default</b> .	<b>CHISHOLM</b>	Uses Lockhart-Martinelli parameter + Gas to Liquid Density Ratio.	<b>DE-LEEUEW</b>	Uses Lockhart-Martinelli parameter + Gas to Liquid Density Ratio + Gas Froude Number (de Leeuw correlation).	<b>STEVEN</b>	Uses Lockhart-Martinelli parameter + Gas to Liquid Density Ratio + Gas Froude Number (Steven correlation).
<b>MURDOCK</b>	Uses Lockhart-Martinelli parameter. This is the <b>default</b> .								
<b>CHISHOLM</b>	Uses Lockhart-Martinelli parameter + Gas to Liquid Density Ratio.								
<b>DE-LEEUEW</b>	Uses Lockhart-Martinelli parameter + Gas to Liquid Density Ratio + Gas Froude Number (de Leeuw correlation).								
<b>STEVEN</b>	Uses Lockhart-Martinelli parameter + Gas to Liquid Density Ratio + Gas Froude Number (Steven correlation).								
<b>WET GAS INPUTS</b>	Click to display a dialog box you use to define specific input values for wet gases.								
<b>REYNOLDS NUMBERS</b>	Click to display a dialog box you use to define the wet gas Reynolds numbers for up to 30 fields.								
<b>DISCHARGE COEFFICIENTS</b>	Click to display a dialog box you use to define the wet gas coefficients for up to 30 fields.								

- Click in the hierarchy menu when you finish defining settings. A confirmation dialog box displays.
- Click **Yes** to apply your changes. The PCSetup screen displays.

### 6.4.5 ISOTR9464

ISOTR9464 settings provide a calculation of the Joule-Thomson coefficient used in upstream temperature correction. The settings define the upstream temperature and pressure input limits and the Joule-Thomson coefficient output limits. This screen displays when you configure the S600+ to use a DP method to calculate gas flow.

- Select **ISOTR9464** from the hierarchy menu. The ISOTR9464 screen displays.

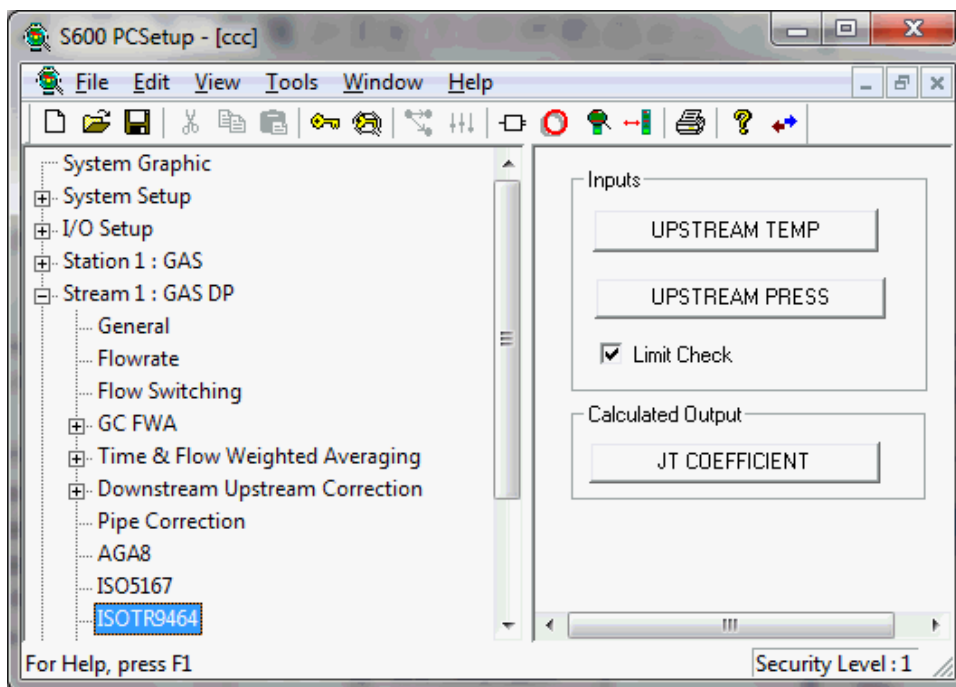

Figure 6-32. ISOTR9464 screen

2. Complete the following fields.

Field	Description
<b>UPSTREAM TEMP</b>	Click to display a Calculation Result dialog box you use to define the mode, keypad value, and the specific alarm limits for upstream temperature.
<b>UPSTREAM PRESS</b>	Click to display a Calculation Result dialog box you use to define the mode, keypad value, and the specific alarm limits for upstream pressure.
<b>Limit Check</b>	Enables limit checking. The default is <b>enabled</b> . With limit checking enabled, the system checks that the temperature is between 0 °C and 100 °C, that the pressure is between 100 and 200 bar, and that methane is > than 80%. If any of these parameters are out of range, the system sets the coefficient to zero, which prevents the calculation of upstream temperature correction.
<b>JT COEFFICIENT</b>	Click to display a Calculation Result dialog box you use to define the mode, keypad value, and the specific alarm limits for the Joule-Thomson coefficient.

3. Click in the hierarchy menu when you finish defining settings. A confirmation dialog box displays.
4. Click **Yes** to apply your changes. The PCSetup screen displays.

## 6.4.6 V-Cone (Mass Flowrate)

V-Cone® mass flowrate settings define the constants and calculation limits for a range of parameters including pressure, density, flow coefficient, and pressure loss. This screen displays when you configure the S600+ to use the V-Cone standard to calculate gas flow through the orifice meter.

Mass flowrate settings also allow you to define alarms. The system activates these alarms when the calculated results are not within the specified limits.

1. Select **V-Cone** from the hierarchy menu. The V-Cone screen displays.

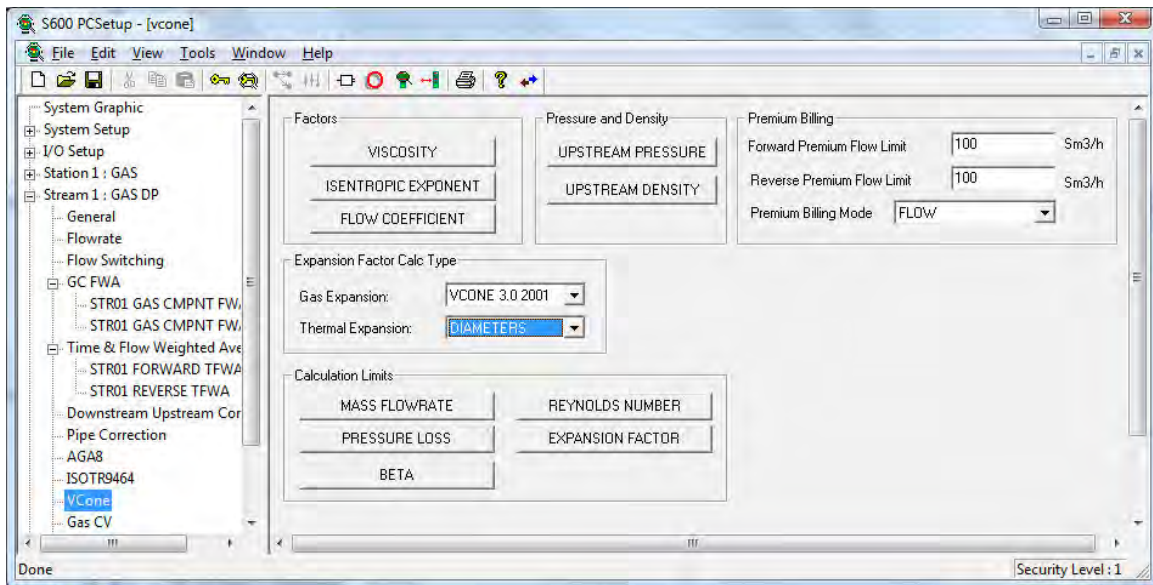

Figure 6-33. V-Cone (Mass Flowrate) screen

2. Complete the following fields.

Field	Description
<b>VISCOSITY</b>	Click to display a Calculation Result dialog box you use to define the mode, keypad value, and the specific alarm limits for viscosity.
<b>ISENTROPIC EXPONENT</b>	Click to display a Calculation Result dialog box you use to define the mode, keypad value, and the specific alarm limits for the isentropic exponent.
<b>FLOW COEFFICIENT</b>	Click to display a Calculation Result dialog box you use to define the mode, keypad value, and the specific alarm limits for the flow coefficient.
<b>Gas Expansion</b>	Identifies the specific gas expansion calculation the S600+ uses. Click ▼ to display all valid values.
<b>VCONE 2.3</b>	The S600+ uses the McCrometer 2.3 V-Cone Flowmeter / ISO5167 Gas Expansion (Y) calculation.
<b>VCONE 3.0 2001</b>	The S600+ uses the McCrometer 3.0 2001 V-Cone Gas Expansion (Y) calculation. This is the <b>default</b> .
<b>WCONE 3.0 2001</b>	The S600+ uses the McCrometer 3.0 2001 Wafer Cone Gas Expansion (Y) calculation.

Field	Description
<b>LIQUID 2001</b>	The S600+ uses a value of 1.0 for the Gas Expansion Factor.
<b>Thermal Expansion</b>	Identifies the specific type of thermal expansion calculation the S600+ uses. Click ▼ to display all valid values.
<b>S500 LEGACY</b>	Sets the Thermal Expansion factor to 1. <b>Note:</b> This option appears <b>only</b> if you select VCONE 2.3 in the Gas Expansion field.
<b>DIAMETERS</b>	The S600+ uses the calibrated diameters in the thermal expansion calculation. This is the <b>default</b> .
<b>BETA RATIO</b>	The S600+ uses the beta ratio in the thermal expansion calculation.
<b>MASS FLOWRATE</b>	Click to display a Calculation Result dialog box you use to define the specific alarm limits for the mass flowrate.
<b>PRESSURE LOSS</b>	Click to display a Calculation Result dialog box you use to define the mode, keypad value, and the specific alarm limits for the pressure loss.
<b>BETA</b>	Click to display a Calculation Result dialog box you use to define the mode, keypad value, and the specific alarm limits for the calculated diameter ratio.
<b>REYNOLDS NUMBER</b>	Click to display a Calculation Result dialog box you use to define the specific alarm limits for the Reynolds number.
<b>EXPANSION FACTOR</b>	Click to display a Calculation Result dialog box you use to define the mode, keypad value, and the specific alarm limits for the expansion factor.
<b>UPSTREAM PRESSURE</b>	Click to display a Calculation Result dialog box you use to define the mode, keypad value, and the specific alarm limits for the upstream pressure.
<b>UPSTREAM DENSITY</b>	Click to display a Calculation Result dialog box you use to define the mode, keypad value, and the specific alarm limits for the upstream density.
<b>Forward Premium Flow Limit</b>	Sets the premium forward flow mode, in which the system increments premium totals whenever the flowrate exceeds the keypad limit. The default is <b>100</b> .
<b>Reverse Premium Flow Limit</b>	Sets the premium reversed flow mode, in which the system increments premium totals whenever the flowrate exceeds the keypad limit. The default is <b>100</b> .
<b>Premium Billing Mode</b>	Indicates the premium total mode, in which the system increments premium totals at the end of the hour only if the hourly total exceeds the keypad limit. Click ▼ to display all valid values. The default is <b>FLOW</b> .

3. Click in the hierarchy menu when you finish defining settings. A confirmation dialog box displays.
4. Click **Yes** to apply your changes. The PCSetup screen displays.

### 6.4.7 Annubar (Mass Flowrate)

Annubar mass flowrate settings define the constants and calculation limits for a range of parameters including pressure, density, flow coefficient, and pressure loss. This screen displays when you configure the S600+ to use the 1998 Dieterich Standard Annubar Diamond II+ to calculate gas flow through the orifice meter.

Mass flowrate settings also allow you to define alarms. The system activates these alarms when the calculated results are not within the specified limits.

1. Select **Annubar** from the hierarchy menu. The Annubar screen displays.

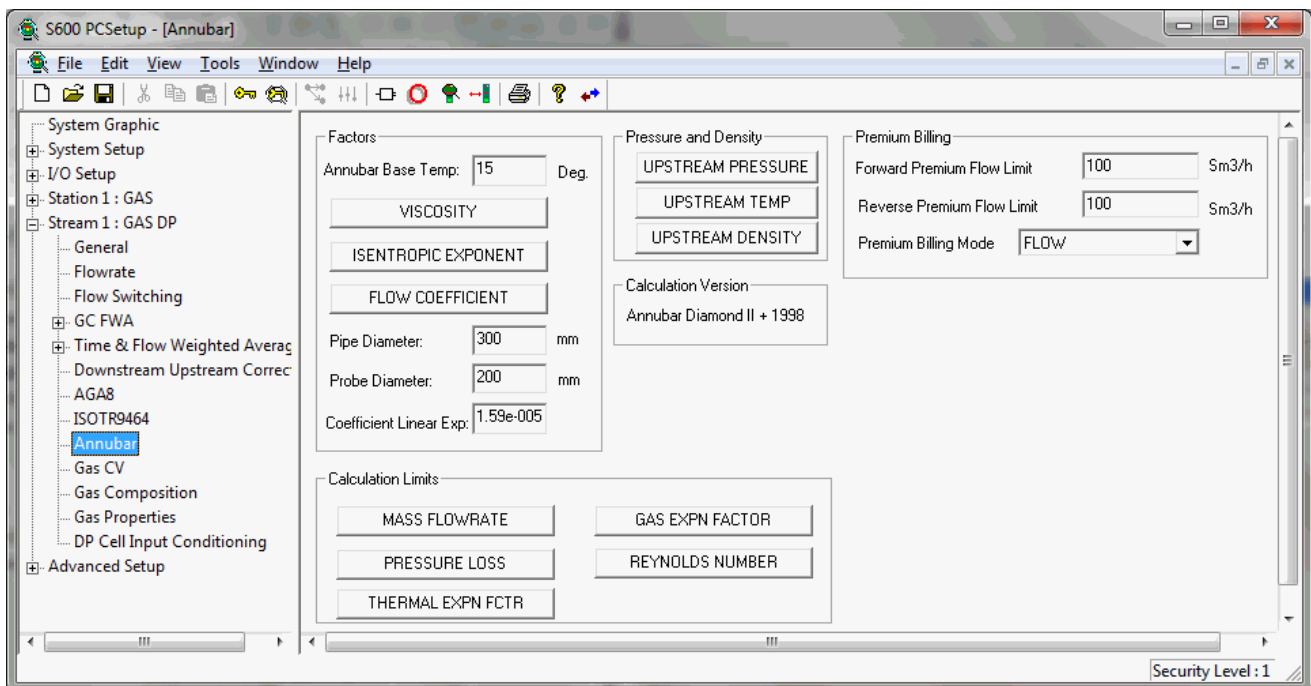

Figure 6-34. Annubar (Mass Flowrate) screen

2. Complete the following fields.

Field	Description
<b>Annubar Base Temp</b>	Sets the Annubar calibration temperature. The default is <b>15</b> .
<b>VISCOSITY</b>	Click to display a Calculation Result dialog box you use to define the mode, keypad value, and the specific alarm limits for viscosity.
<b>ISENTROPIC EXPONENT</b>	Click to display a Calculation Result dialog box you use to define the mode, keypad value, and the specific alarm limits for the isentropic exponent.
<b>FLOW COEFFICIENT</b>	Click to display a Calculation Result dialog box you use to define the mode, keypad value, and the specific alarm limits for the flow coefficient.
<b>Pipe Diameter</b>	Sets, in millimeters, the uncorrected internal pipe diameter. The default is <b>300</b> .
<b>Probe Diameter</b>	Sets, in millimeters, the corrected internal probe diameter. The default is <b>200</b> .

Field	Description
<b>Coefficient Linear Exp</b>	Sets the coefficient the S600+ uses for linear expansion. The default is <b>1.59e-005</b> .
<b>UPSTREAM PRESSURE</b>	Click to display a Calculation Result dialog box you use to define the mode, keypad value, and the specific alarm limits for the upstream pressure.
<b>UPSTREAM TEMP</b>	Click to display a Calculation Result dialog box you use to define the mode, keypad value, and the specific alarm limits for the upstream temperature.
<b>UPSTREAM DENSITY</b>	Click to display a Calculation Result dialog box you use to define the mode, keypad value, and the specific alarm limits for the upstream density.
<b>Calculation Version</b>	This <b>read-only</b> field shows the default calculation Config600 uses for the Annubar settings, based on the Annubar device in use.
<b>Forward Premium Flow Limit</b>	In Premium Billing FLOW mode and Flow Direction FORWARD, sets a flowrate limit above which the system increments forward premium totals whenever the flowrate exceeds the keypad limit. In Premium Billing TOTAL mode and Flow Direction FORWARD, sets a total limit above which the system increments forward premium totals whenever the period total exceeds the keypad limit. The default is <b>100</b> .
<b>Reverse Premium Flow Limit</b>	In Premium Billing FLOW mode and Flow Direction REVERSE, sets a flowrate limit above which the system increments reverse premium totals whenever the flowrate exceeds the keypad limit. In Premium Billing TOTAL mode and Flow Direction REVERSE, sets a total limit above which the system increments reverse premium totals whenever the period total exceeds the keypad limit. The default is <b>100</b> .
<b>Premium Billing Mode</b>	Indicates the premium total mode, in which the system increments premium totals at the end of a period only if the period total exceeds the keypad limit. Click ▼ to display all valid values. The default is <b>FLOW</b> .
<b>MASS FLOWRATE</b>	Click to display a Calculation Result dialog box you use to define the specific alarm limits for the mass flowrate.
<b>PRESSURE LOSS</b>	Click to display a Calculation Result dialog box you use to define the mode, keypad value, and the specific alarm limits for the pressure loss.
<b>THERMAL EXPN FCTR</b>	Click to display a Calculation Result dialog box you use to define the mode, keypad value, and the specific alarm limits for the thermal expansion factor.
<b>GAS EXPN FACTOR</b>	Click to display a Calculation Result dialog box you use to define the mode, keypad value, and the specific alarm limits for the gas expansion factor.
<b>REYNOLDS NUMBER</b>	Click to display a Calculation Result dialog box you use to define the specific alarm limits for the Reynolds number.

- Click in the hierarchy menu when you finish defining settings. A confirmation dialog box displays.
- Click **Yes** to apply your changes. The PCSetup screen displays.

### 6.4.8 Pure Gas Air

Pure Gas Air mass flowrate settings define the constants and calculation limits for a range of parameters including pressure, density, flow coefficient, and pressure loss. This screen displays when you configure the S600+ to use the Pure Gas and Air standards to calculate gas flow through the orifice meter. flowrate

Mass flowrate settings also allow you to define alarms. The system activates these alarms when the calculated results are not within the specified limits.

The calculations use ISO6976 tables for CV and Molar Mass.

1. Select **Pure Gas/Air** from the hierarchy menu. The Pure Gas/Air screen displays.

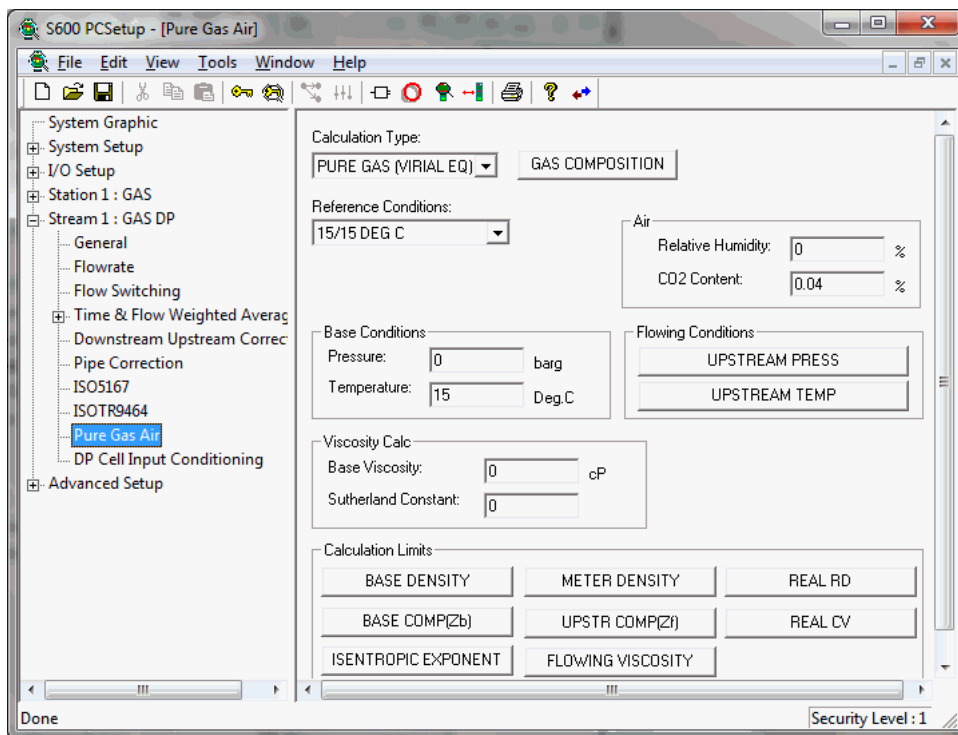

Figure 6-35. Pure Gas/Air screen

2. Complete the following fields.

Field/Button	Description
<b>Calculation Type</b>	Indicates the specific type of Pure Gas or Air calculation the S600+ uses. Click ▼ to display all valid values. The default is <b>PURE GAS (VIRIAL EQ)</b> .
<b>Pure Gas (Virial Eq)</b>	The S600+ uses a Third Order Virial Equation with derived constants to calculate the virial coefficients.
<b>Air (BIPM 1981/91)</b>	The S600+ uses the BIPM Equation for the Determination of Density of Moist Air (1981/91) by R.S Davies.
<b>Reference Conditions</b>	Indicates the reference conditions the S600+ uses for the Pure Gas/Air calculation. Click ▼ to display all valid values. The default is <b>15/15 DEG C</b> .
<b>GAS COMPOSITION</b>	Click to display a dialog box you use to define the gas percentages of the mixture.



<b>Field/Button</b>	<b>Description</b>
<b>Relative Humidity</b>	Sets the relative humidity for air at base conditions. The default is <b>0</b> .
<b>CO2 Content</b>	Sets the percentage of CO2 content at base conditions. The default is <b>0.04</b> .
<b>Pressure</b>	Sets the pressure at base conditions. The default is <b>0</b> .
<b>Temperature</b>	Sets the temperature at base conditions. The default is <b>15</b> .
<b>UPSTREAM PRESSURE</b>	Click to display a Calculation Result dialog box you use to define the mode, keypad value, and the specific alarm limits for the upstream pressure.
<b>UPSTREAM TEMP</b>	Click to display a Calculation Result dialog box you use to define the mode, keypad value, and the specific alarm limits for the upstream temperature.
<b>Base Viscosity</b>	Sets the base viscosity value the S600+ uses for viscosity calculations. The default is <b>0</b> .
<b>Sutherland Constant</b>	Sets the Sutherland constant the S600+ uses for viscosity calculations. The default is <b>0</b> .
<b>BASE DENSITY</b>	Click to display a Calculation Result dialog box you use to define the mode, keypad value, and the specific alarm limits for the base density
<b>BASE COMP(Zb)</b>	Click to display a Calculation Result dialog box you use to define the mode, keypad value, and the specific alarm limits for the base compressibility (Zb).
<b>ISENTROPIC EXPONENT</b>	Displays a Calculation Result dialog box you use to define the mode, keypad value, and the specific alarm limits for the Isentropic exponent.
<b>METER DENSITY</b>	Displays a Calculation Result dialog box you use to define the mode, keypad value, and the specific alarm limits for the meter density.
<b>UPSTR COMP(Zf)</b>	Displays a Calculation Result dialog box you use to define the mode, keypad value, and the specific alarm limits for the upstream compressibility (Zf).
<b>FLOWING VISCOSITY</b>	Displays a Calculation Result dialog box you use to define the mode, keypad value, and the specific alarm limits for the flowing viscosity.
<b>REAL RD</b>	Displays a Calculation Result dialog box you use to define the mode, keypad value, and the specific alarm limits for the real relative density.
<b>REAL CV</b>	Displays a Calculation Result dialog box you use to define the mode, keypad value, and the specific alarm limits for the real calorific value (CV).

3. Click in the hierarchy menu when you finish defining settings. A confirmation dialog box displays.
4. Click **Yes** to apply your changes. The PCSetup screen displays.

### 6.4.9 Gas CV (ISO6976 or GPA2172/ASTM D3588)

Calorific Value (CV) settings define the constants and calculation limits for ideal and real calorific values. This screen displays when you configure the S600+ to use either the ISO6976 or GPA2172/ASTM D3588 standard (defined in step 5, Options, of the PCSetup Editor's Configuration Wizard) to calculate the calorific value (heating value) of the gas mixture.

Calorific value settings also allow you to define alarms. The system activates these alarms when the calculated results are not within the specified limits.

1. Select **Gas CV** from the hierarchy menu. The Calorific Value screen displays.

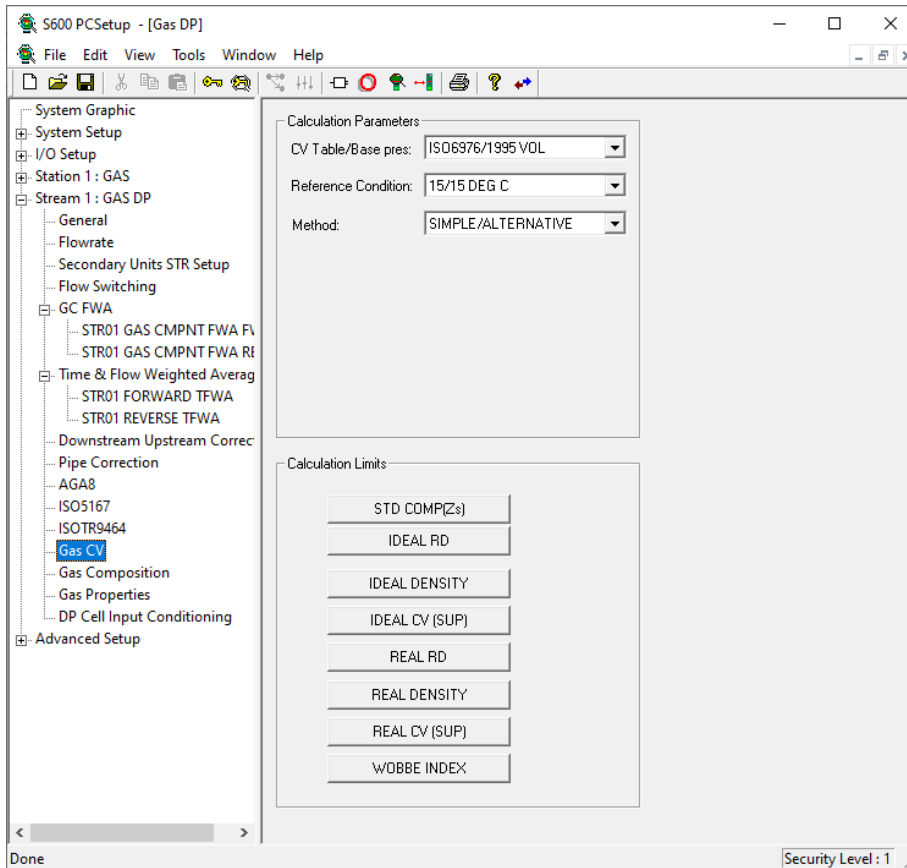

Figure 6-36. Gas CV (ISO6976 or GPA2172/ASTM D3588) screen

2. Complete the following fields.

Field	Description
<b>CV Table</b>	Identifies the specific compressibility value the program uses. Click ▼ to display all valid values. The default is <b>ISO6976/1995</b> .
<b>ISO6976/1995 Vol</b>	Calculates CV based on volume, using the 1995 table. This is the <b>default</b> if you choose CV ISO6976 as your initial stream option. <b>Note:</b> This option displays <b>only</b> if you initially configure the stream to use CV ISO6976.
<b>ISO6976/1995 Mass</b>	Calculates CV based on mass, using the 1995 table. <b>Note:</b> This option displays <b>only</b> if you initially configure the stream to use CV ISO6976.
<b>ISO6976/1983 Vol</b>	Calculates CV based on volume, using the 1983 table. <b>Note:</b> This option displays <b>only</b> if you initially configure the stream to use CV ISO6976.

Field	Description
	Support for the 1983 table is limited to superior volumetric at 15/15.
<b>ISO6976/2016 Vol</b>	Calculates CV based on volume, using the 2016 table. <b>Note:</b> This option displays <b>only</b> if you initially configure the stream to use CV ISO6976.
<b>ISO6976/2016 Mass</b>	Calculates CV based on mass, using the 2016 table. <b>Note:</b> This option displays <b>only</b> if you initially configure the stream to use CV ISO6976.
<b>GPA/2003 AGA (14.73)</b>	Calculates CV based on a base press of 14.73 psia. This is the <b>default</b> if you choose CV GPA2172-ASTMD3588 as your initial stream option. <b>Note:</b> This option displays <b>only</b> if you initially configure the stream to use CV GPA2172-ASTMD3588.
<b>GPA/2003 ISO (14.696)</b>	Calculates CV based on a base press of 14.696 psia. <b>Note:</b> This option displays <b>only</b> if you initially configure the stream to use CV GPA2172-ASTMD3588.
<b>GPA/2000 AGA (14.73)</b>	Calculates CV based on a base press of 14.73 psia. <b>Note:</b> This option displays <b>only</b> if you initially configure the stream to use CV GPA2172-ASTMD3588.
<b>GPA/2000 ISO (14.696)</b>	Calculates CV based on a base press of 14.696 psia. <b>Note:</b> This option displays <b>only</b> if you initially configure the stream to use CV GPA2172-ASTMD3588.
<b>GPA/1996 AGA (14.73)</b>	Calculates CV based on a base press of 14.73 psia. <b>Note:</b> This option displays <b>only</b> if you initially configure the stream to use CV GPA2172-ASTMD3588.
<b>GPA/1996 ISO (14.696)</b>	Calculates CV based on a base press of 14.696 psia. <b>Note:</b> This option displays <b>only</b> if you initially configure the stream to use CV GPA2172-ASTMD3588.
<b>GPA/2016 Pb (14.65)</b>	Calculates CV based on a base press of 14.65 psia. <b>Note:</b> This option displays <b>only</b> if you initially configure the stream to use CV GPA2172-ASTMD3588.

Field	Description
<b>Reference Condition</b>	<p>Indicates the <math>t_1/t_2</math> value, where <math>t_1</math> is the calculation reference temperature for combustion and <math>t_2</math> is the reference condition for metering. The default is <b>15/15 DEG C</b>.</p> <p><b>Note:</b></p> <ul style="list-style-type: none"> <li>▪ For <b>ISO6976 1983 VOL</b> selection, the 60/60F and 15/15.55 Deg C selections are <b>not</b> supported.</li> <li>▪ For <b>ISO6976 1995 VOL</b> and <b>MASS</b> selections, the 60/60F selection refers to a combustion temperature (<math>t_1</math>) of 60 Deg F and a metering temperature (<math>t_2</math>) of 15 Deg C. The 15/15.55 Deg C selection is <b>not</b> supported.</li> </ul> <p><b>Note:</b> For Binary.app versions <b>prior to 06.30a</b>, the 60/60F selection refers to a combustion temperature (<math>t_1</math>) of 15 Deg C and a metering temperature (<math>t_2</math>) of 15 Deg C.</p> <ul style="list-style-type: none"> <li>▪ For <b>ISO6976 2016 VOL</b> and <b>MASS</b> selections, the 60/60F selection refers to a combustion temperature (<math>t_1</math>) of 60 Deg F and a metering temperature (<math>t_2</math>) of 15 Deg C. The 15/15.55 Deg C selection refers to a combustion temperature (<math>t_1</math>) of 15.55 Deg C (60 Deg F) and a metering temperature (<math>t_2</math>) of 15.55 Deg C (60 Deg F).</li> </ul> <p><b>Note:</b> For Binary.app versions <b>prior to 06.30a</b>, the 60/60F selection refers to a combustion temperature (<math>t_1</math>) of 15 Deg C and a metering temperature (<math>t_2</math>) of 15 Deg C.</p>
<b>Method</b>	<p>If you select CV ISO6976 in your initial configuration and you select the 1995 standard, you have the choice of Alternative or Definitive methods (using table 4 Mass / table 5 volume) for calculating the ideal, superior, and inferior CV values. This selection is not applicable to the 1983 or 2016 standards.</p> <p>If you select <b>CV GPA2172-ASTMD3588</b> in your initial configuration, you have the choice of the Simple (using equation 7 f from the GPA2172-ASTMD3588-09 standard) or Rigorous (using equations 8 &amp; 9 from the GPA2172-ASTMD3588-09 standard) methods for calculating the standard compressibility.</p> <p><b>Note:</b> This option is valid <b>only</b> for configurations created with Config600 version 3.1 or greater.</p>
<b>User Temp T2</b>	<p>Applicable to the <b>ISO6976 2016 VOL</b> and <b>ISO6976 2016 MASS</b> selections. Also applicable to the <b>ISO6976 1995 VOL</b> selection when the Definitive method is selected.</p> <p><b>Note:</b> It may be necessary to add this item to a display so that it can be correctly initialised.</p>
<b>User Press P2</b>	<p>Applicable to the <b>ISO6976 2016 VOL</b> and <b>ISO6976 1995 VOL</b> selections when the Definitive method is selected.</p> <p><b>Note:</b> It may be necessary to add this item to a display so that it can be correctly initialised.</p>

Field	Description
<b>Table Revision</b>	This replaces the above AGA and ISO selections in the CV Table field for GPA 2172. You can select the GPA2145 table revision from one of the following: <ul style="list-style-type: none"> <li>▪ 1996</li> <li>▪ 2000</li> <li>▪ 2003</li> <li>▪ 2009</li> </ul> <b>Note:</b> This option is valid <b>only</b> for configurations created with Config600 version 3.1 or greater.
<b>BASE COMP(Zb)</b>	Click to supply an externally calculated base compressibility from another calculation. The system uses the entered value in GPA2172-ASTMD3588 calculations instead of using its own internally calculated value based on the composition input.
<b>Composition Type</b>	Defines the composition input type. Valid options are: <ul style="list-style-type: none"> <li>▪ mass to energy using mole percent</li> <li>▪ mass to energy using mole fraction</li> <li>▪ volume to energy using mole percent</li> <li>▪ volume to energy using mole fraction</li> </ul> <b>Note:</b> This option is valid <b>only</b> for AGA5 configurations.

3. Click any of the following buttons to define calculation limits for either the ISO6876 or GPA standard.

Button	Description
<b>STD COMP(Zs)</b>	Click to display a Calculation Result dialog box you use to define the mode, keypad value, and the specific alarm limits for standard compressibility (Zs).
<b>IDEAL RD</b>	Click to display a Calculation Result dialog box you use to define the mode, keypad value, and the specific alarm limits for ideal relative density.
<b>IDEAL DENSITY</b>	Click to display a Calculation Result dialog box you use to define the mode, keypad value, and the specific alarm limits for ideal density.
<b>IDEAL CV (SUP)</b>	Click to display a Calculation Result dialog box you use to define the mode, keypad value, and the specific alarm limits for ideal calorific value. <p><b>Note:</b> The superior CV is output to calc field 1 of the CV object and the inferior CV is output to calc field 3. You can select either by the CV object mode from the S600+ front panel.</p>
<b>Gross HV</b>	Click to displays a Calculation Result dialog box you use to define the mode, keypad value, and the specific alarm limits for gross heating value. <p><b>Note:</b> This field displays <b>only</b> if you initially configure the stream to use CV GPA2172-ASTMD3588.</p>
<b>REAL RD</b>	Click to display a Calculation Result dialog box you use to define the mode, keypad value, and the specific alarm limits for real relative density.
<b>REAL DENSITY</b>	Click to display a Calculation Result dialog box you use to define the mode, keypad value, and the specific alarm limits for real density.

Button	Description
<b>REAL CV (SUP)</b>	Click to display a Calculation Result dialog box you use to define the mode, keypad value, and the specific alarm limits for real calorific value. <b>Note:</b> The superior CV is output to calc field 1 of the CV object and the inferior CV is output to calc field 3. You can select either by the CV object mode from the S600+ front panel.
<b>WOBBE INDEX</b>	Click to display a Calculation Result dialog box you use to define the mode, keypad value, and the specific alarm limits for real calorific value. <b>Note:</b> The Wobbe Index is calculated using the Real Superior CV.
<b>REAL VOL IDEAL HV</b>	Displays a Calculation Result dialog box you use to define the mode, keypad value, and the specific alarm limits for the real volume ideal heating value. <b>Note:</b> This field displays <b>only</b> if you initially configure the stream to use CV GPA2172-ASTMD3588.

4. Click in the hierarchy menu when you finish defining settings. A confirmation dialog box displays.
5. Click **Yes** to apply your changes. The PCSetup screen displays.

### 6.4.10 SGERG (Compressibility)

SGERG settings define the constants and calculation limits for ideal and real calorific values. This screen displays when you configure the S600+ to use the SGERG standard to calculate the compressibility of the gas mixture.

SGERG settings also allow you to define alarms. The system activates these alarms when the calculated results are not within the specified limits.

1. Select **SGERG** from the hierarchy menu. The SGERG screen displays.

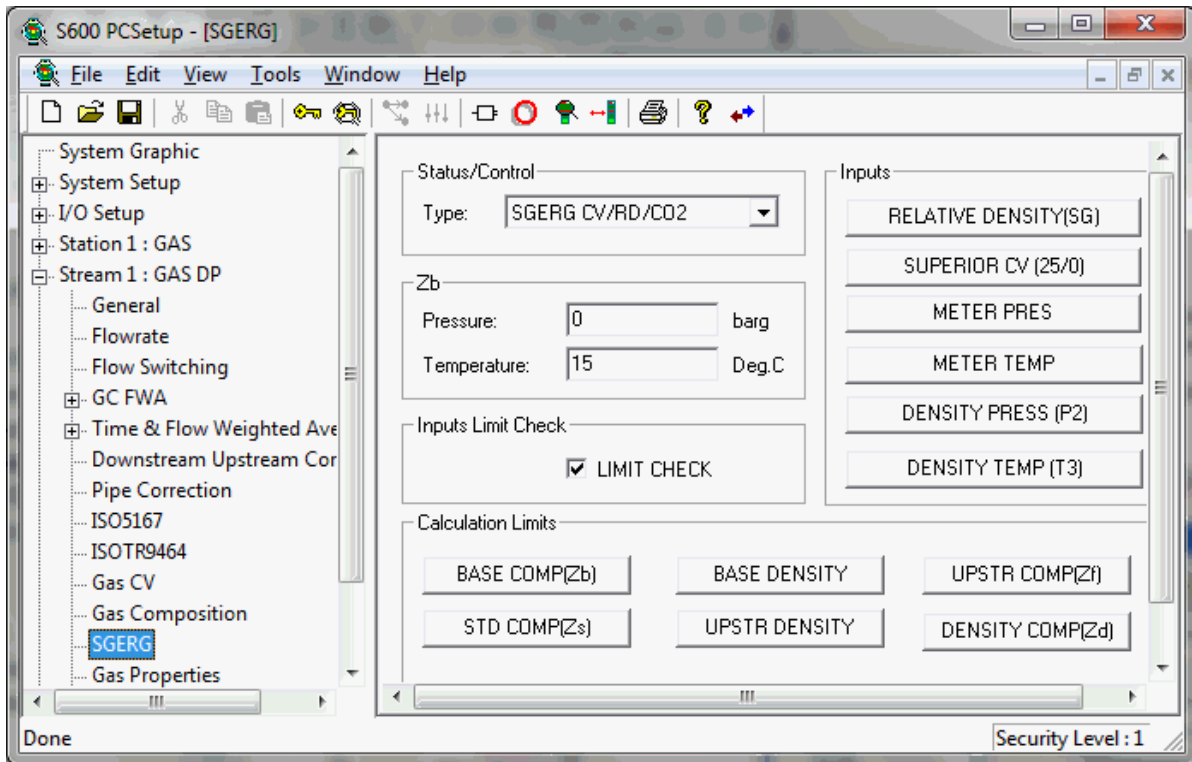

Figure 6-37. SGERG (Compressibility) screen

2. Complete the following fields.

Field Type	Description
<b>SGERG CV/RD/CO2</b>	Indicates the specific type of SGERG calculation the S600+ uses. Click ▼ to display all valid values. Calculate SGERG from calorific value, relative density, and CO <sub>2</sub> . This is the <b>default</b> .
<b>SGERG CV/RD/CO2/H2</b>	Calculate SGERG from calorific value, relative density, CO <sub>2</sub> , and hydrogen.
<b>ISO CV/RD/CO2</b>	Calculate ISO 12213-3 from calorific value, relative density, and CO <sub>2</sub> .
<b>ISO CV/RD/CO2/H2</b>	Calculate ISO 12213-3 from calorific value, relative density, CO <sub>2</sub> , and hydrogen.
<b>SGERG CV/CO2/N2</b>	Calculate SGERG from calorific value, CO <sub>2</sub> , and nitrogen.
<b>SGERG CV/CO2/N2/H2</b>	Calculate SGERG from calorific value, CO <sub>2</sub> , nitrogen, and hydrogen.
<b>GOST BD/CO2/N2</b>	Calculate GOST from base density, CO <sub>2</sub> , and nitrogen.
<b>SGERG CV/RD/N2</b>	Calculate SGERG from calorific value, relative density, and nitrogen.
<b>SGERG CV/RD/N2/H2</b>	Calculate SGERG from calorific value, relative density, nitrogen, and hydrogen.
<b>SGERG RD/CO2/N2</b>	Calculate SGERG from relative density, CO <sub>2</sub> , and nitrogen.

Field	Description
<b>SGERG RD/CO2/N2/H2</b>	Calculate SGERG from relative density, CO <sub>2</sub> , nitrogen, and hydrogen.
<b>Pressure</b>	Sets the pressure the S600+ uses to calculate compressibility at base conditions. The default is <b>0</b> .
<b>Temperature</b>	Sets the temperature the S600+ uses to calculate compressibility at base conditions. The default is <b>15</b> .
<b>Inputs Limit Check</b>	Performs limit checking on the inputs. The <b>default</b> is checked (limit checking occurs).

- Click any of the following buttons to define SGERG miscellaneous values and calculation limits.

Button	Description
<b>RELATIVE DENSITY (SG)</b>	Click to display a Calculation Result dialog box you use to define the mode, keypad value, and the specific alarm limits for the relative density. <b>Note:</b> Relative density is assumed to be at reference 0°C.
<b>SUPERIOR CV (25/0)</b>	Click to display a Calculation Result dialog box you use to define the mode, keypad value, and the specific alarm limits for the calculated calorific value. <b>Note:</b> Calorific value is assumed to be 25/0.
<b>METER PRES</b>	Click to display a Calculation Result dialog box you use to define the mode, keypad value, and the specific alarm limits for the upstream meter pressure.
<b>METER TEMP</b>	Click to display a Calculation Result dialog box you use to define the mode, keypad value, and the specific alarm limits for the upstream meter temperature.
<b>DENSITY PRESS (P2)</b>	Click to display a Calculation Result dialog box you use to define the mode, keypad value, and the specific alarm limits for the density pressure (P2).
<b>BASE COMP(Zb)</b>	Click to display a Calculation Result dialog box you use to define the mode, keypad value, and the specific alarm limits for the base compressibility (Zb).
<b>STD COMP(Zs)</b>	Click to display a Calculation Result dialog box you use to define the mode, keypad value, and the specific alarm limits for the standard compressibility (Zs).
<b>BASE DENSITY</b>	Click to display a Calculation Result dialog box you use to define the mode, keypad value, and the specific alarm limits for the calculated base density.
<b>UPSTR DENSITY</b>	Click to display a Calculation Result dialog box you use to define the mode, keypad value, and the specific alarm limits for the upstream density.
<b>UPSTR COMP(Zf)</b>	Click to display a Calculation Result dialog box you use to define the mode, keypad value, and the specific alarm limits for the upstream compressibility factor.
<b>DENSITY COMP(Zd)</b>	Click to display a Calculation Result dialog box you use to define the mode, keypad value, and the specific alarm limits for the densitometer compressibility.

- Click in the hierarchy menu when you finish defining settings. A confirmation dialog box displays.
- Click **Yes** to apply your changes. The PCSetup screen displays.



### 6.4.11 NX19 (Compressibility)

NX19 settings define the constants and calculation limits for a range of parameters including pressure, temperature, density, and compressibility factors. This screen displays when you configure the S600+ to use the NX19 standard to calculate base compressibility and density, standard compressibility, flowing compressibility and density, and compressibility at density conditions.

NX19 settings also allow you to define alarms. The system activates these alarms when the calculated results are not within the specified limits.

1. Select **NX19** from the hierarchy menu.

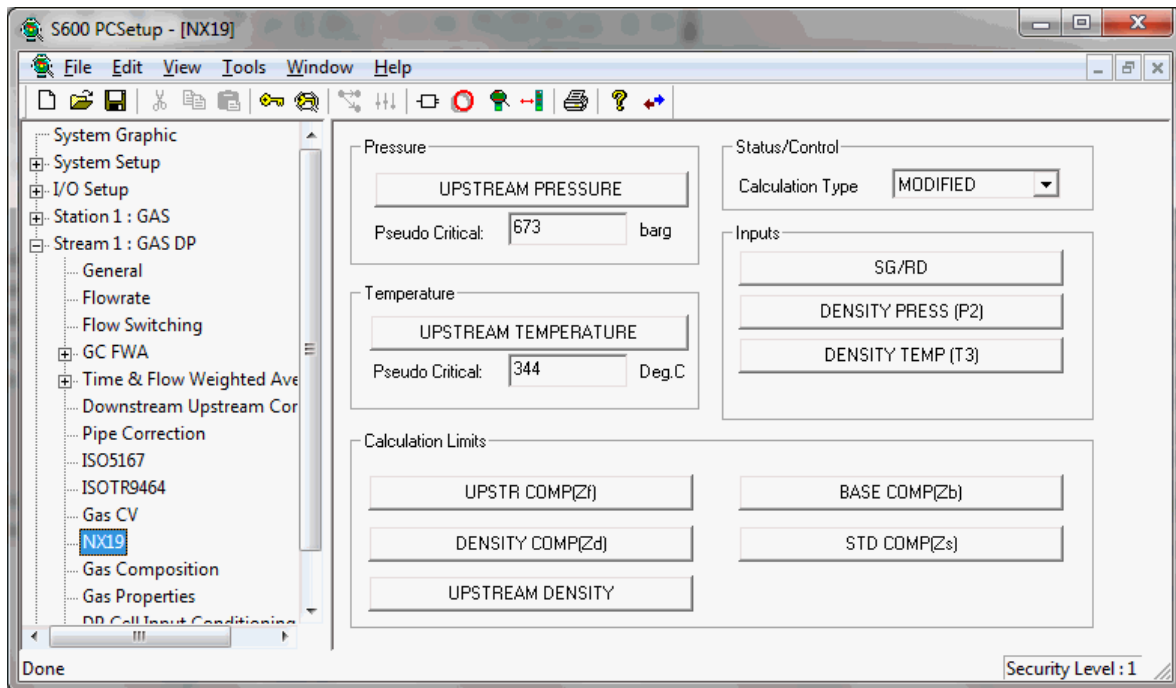

Figure 6-38. NX19 (Compressibility) screen

2. Complete the following fields.

Field	Description
<b>UPSTREAM PRESSURE</b>	Click to display a Calculation Result dialog box you use to define the mode, keypad value, and the specific alarm limits for the upstream pressure.
<b>Pseudo Critical</b>	Sets the pseudo-critical limits for pressure. The default is <b>673</b> .
<b>UPSTREAM TEMPERATURE</b>	Click to display a Calculation Result dialog box you use to define the mode, keypad value, and the specific alarm limits for the upstream temperature. <b>Note:</b> This button displays <b>only</b> if you select the NX19 UPSTR component.
<b>Pseudo Critical</b>	Sets the pseudo-critical limits for temperature. The default is <b>344</b> .

Field	Description
<b>Calculation Type</b>	Indicates the calculation type the S600+ uses for the specific gravity/relative density calculation. Click ▼ to display all valid values.
	<b>1962</b> Use AGA manual, December 1962 to determine supercompressibility factor for natural gas. Assumes reference conditions at 60° F.
	<b>MODIFIED</b> Use NX-19 (Mod). Assumes reference condition at 0° C. This is the <b>default</b> .
	<b>VDI/VDE 2040</b> Use VDI/VDE 2040. Assumes reference condition at 0° C.
<b>SG/RD</b>	Click to display a Calculation Result dialog box you use to define the mode, keypad value, and the specific alarm limits for the specific gravity/relative density.
<b>DENSITY PRESS (P2)</b>	Click to display a Calculation Result dialog box you use to define the mode, keypad value, and the specific alarm limits for the density pressure (P2).
<b>DENSITY TEMP (T3)</b>	Click to display a Calculation Result dialog box you use to define the mode, keypad value, and the specific alarm limits for the density temperature (T3).
<b>UPSTR COMP (Zf)</b>	Click to display a Calculation Result dialog box you use to define the mode, keypad value, and the specific alarm limits for the upstream compressibility factor.
<b>DENSITY COMP (Zd)</b>	Click to display a Calculation Result dialog box you use to define the mode, keypad value, and the specific alarm limits for the densitometer compressibility.
<b>UPSTREAM DENSITY</b>	Click to display a Calculation Result dialog box you use to define the mode, keypad value, and the specific alarm limits for the upstream density.
<b>BASE COMP(Zb)</b>	Click to display a Calculation Result dialog box you use to define the mode, keypad value, and the specific alarm limits for upstream compressibility.
<b>STD COMP(Zs)</b>	Click to display a Calculation Result dialog box you use to define the mode, keypad value, and the specific alarm limits for standard compressibility. <b>Note:</b> This button displays <b>only</b> if you select the NX19 STND component.

3. Click in the hierarchy menu when you finish defining settings. A confirmation dialog box displays.
4. Click **Yes** to apply your changes. The PCSetup screen displays.

### 6.4.12 PTZ (Compressibility)

PTZ settings take the pressure, temperature, and calculated values from the NX19 compressibility calculations to calculate an upstream density. This screen displays when you configure the S600+ to use the PTZ calculation and is supported **only** by older configurations.

PTZ settings also allow you to define alarms. The system activates these alarms when the calculated results are not within the specified limits.

1. Select **PTZ** from the hierarchy menu. The PTZ screen displays.

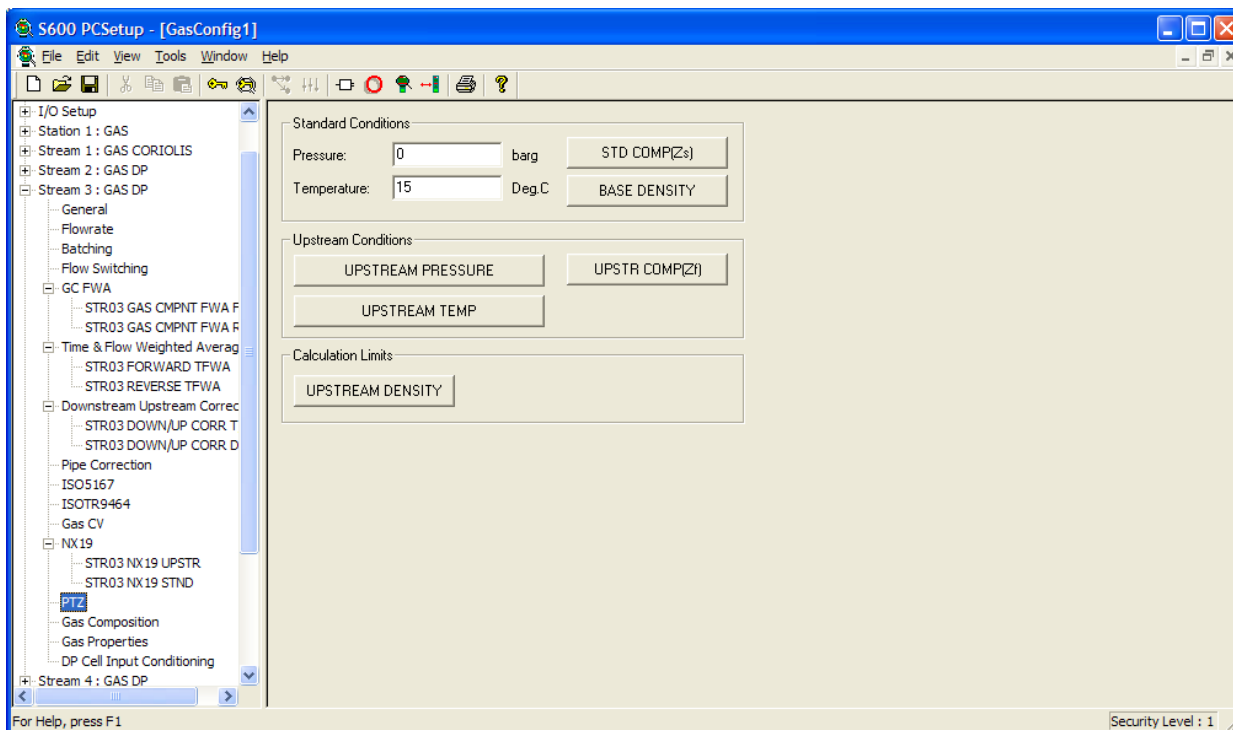

Figure 6-39. PTZ (Compressibility) screen

2. Complete the following fields.

Field	Description
<b>Pressure</b>	Sets pressure at base conditions. The default is <b>0</b> .
<b>Temperature</b>	Sets temperature at base conditions. The default is <b>15</b> .
<b>STD COMP(Zs)</b>	Click to display a Calculation Result dialog box you use to define the mode, keypad value, and the specific alarm limits for the standard compressibility (Zs).
<b>BASE DENSITY</b>	Click to display a Calculation Result dialog box you use to define the mode, keypad value, and the specific alarm limits for the base density.
<b>UPSTREAM PRESSURE</b>	Click to display a Calculation Result dialog box you use to define the mode, keypad value, and the specific alarm limits for the upstream pressure.
<b>UPSTREAM TEMP</b>	Click to display a Calculation Result dialog box you use to define the mode, keypad value, and the specific alarm limits for the upstream temperature.
<b>UPSTR COMP(Zf)</b>	Click to display a Calculation Result dialog box you use to define the mode, keypad value, and the specific alarm limits for the upstream compressibility (Zf).
<b>UPSTREAM DENSITY</b>	Click to display a Calculation Result dialog box you use to define the mode, keypad value, and the specific alarm limits for the upstream density.

3. Click in the hierarchy menu when you finish defining settings. A confirmation dialog box displays.

4. Click **Yes** to apply your changes. The PCSetup screen displays.

### 6.4.13 AGA3 (Volume or Mass Flowrate)

AGA3 settings define the constants and calculation limits for a range of parameters including pressure, temperature, density, and compressibility factors. This screen displays when you configure the S600+ to use the AGA3 standard to calculate gas flow through the orifice meter.

AGA3 settings also allow you to define alarms. The system activates these alarms when the calculated results are not within the specified limits.

You select the AGA3 Volume or AGA3 Mass calculations during the PCSetup Editor’s Configuration Wizard because the choice affect the totalisation configuration.

1. Select **AGA3** from the hierarchy menu. The AGA3 screen displays.

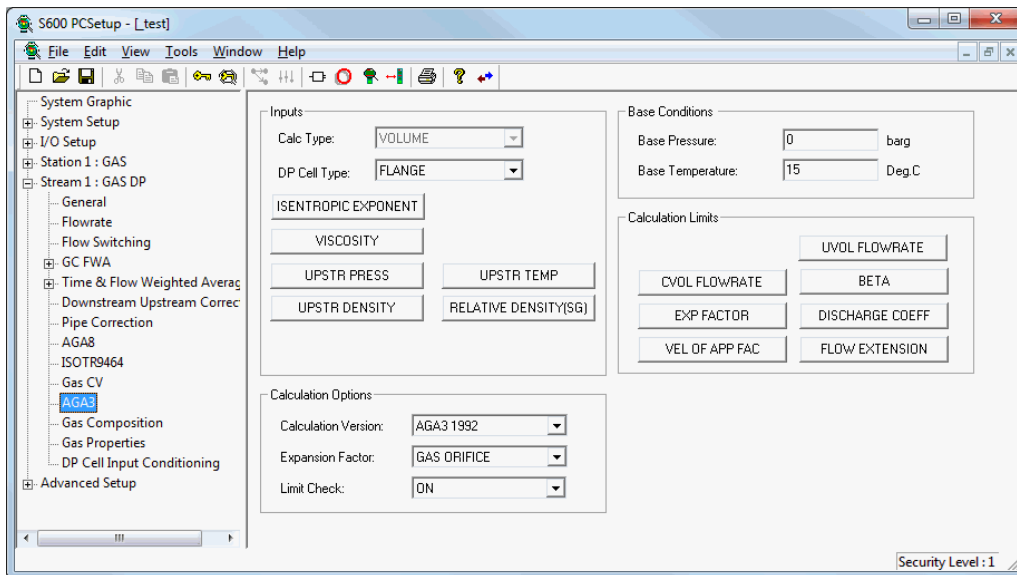

Figure 6-40. AGA3 (Volume Flowrate) screen

2. Complete the following Inputs fields.

Field	Description
<b>Calc Type</b>	This <b>read-only</b> field shows the basis (volume or mass) for the AGA3 calculation.
<b>DP Cell Type</b>	Indicates the position of the differential pressure taps on the metering assembly. Click ▼ to display all valid values. The default is <b>FLANGE</b> .
<b>ISENTROPIC EXPONENT</b>	Click to display a Calculation Result dialog box you use to define the mode, keypad value, and the specific alarm limits for the isentropic exponent.
<b>VISCOSITY</b>	Click to display a Calculation Result dialog box you use to define the mode, keypad value, and the specific alarm limits for viscosity.
<b>UPSTR PRESS</b>	Click to display a Calculation Result dialog box you use to define the mode, keypad value, and the specific alarm limits for upstream pressure.
<b>UPSTR DENSITY</b>	Click to display a Calculation Result dialog box you use to define the mode, keypad value, and the specific alarm limits for upstream density.

Field	Description
<b>RSMT Dish Calib Factor</b>	Indicates the discharge coefficient calibration factor for the Rosemount 1595 conditioning orifice plate. <b>Note:</b> This field displays <b>only</b> if you select the AGA3 RSMT 1595 Calculation Version.
<b>UPSTR TEMP</b>	Click to display a Calculation Result dialog box you use to define the mode, keypad value, and the specific alarm limits for upstream temperature.
<b>RELATIVE DENSITY (SG)</b>	Click to display a Calculation Result dialog box you use to define the mode, keypad value, and the specific alarm limits for the relative density.

3. Enter the base pressure under standard conditions.
4. Enter the base temperature under standard conditions.
5. Click any of the following buttons to define AGA3 calculation limits.

Button	Description
<b>CVOL FLOWRATE</b>	Click to display a Calculation Result dialog box you use to define the specific alarm limits for the corrected volume flowrate.
<b>EXP FACTOR</b>	Click to display a Calculation Result dialog box you use to define the mode, keypad value, and the specific alarm limits for the expansion factor.
<b>VEL OF APP FACTOR</b>	Click to display a Calculation Result dialog box you use to define the specific alarm limits for the velocity of approach factor. <b>Note:</b> This is a mathematical expression that relates the velocity of flowing fluid in the orifice meter house to the velocity in the orifice plate bore.
<b>UVOL FLOWRATE</b>	Click to display a Calculation Result dialog box you use to define the specific alarm limits for the uncorrected volume flowrate.
<b>BETA</b>	Click to display a Calculation Result dialog box you use to define the specific alarm limits for the calculated diameter ratio.
<b>DISCHARGE COEFF</b>	Click to display a Calculation Result dialog box you use to define the specific alarm limits for the calculated orifice plate coefficient of discharge.
<b>FLOW EXTENSION</b>	Click to display a Calculation Result dialog box you use to define the mode, keypad value, and the specific alarm limits for the flow extension.

6. Select a calculation option.

Field	Description
<b>Calculation Version</b>	Sets the version of calculation. Click ▼ to display all valid values. The default is <b>AGA3-1992</b> .
<b>Expansion Factor</b>	Displays options for calculating the fluid expansion factor. Click ▼ to display all valid versions.
	<b>GAS ORIFICE</b> Use the expansion factor formula as defined by calculation you select in the <b>Calculation Version</b> field. This is the <b>default</b> .
	<b>LIQUID ORIFICE</b> Use an Expansion Factor = 1.0 (no expansion).

Field	Description
<b>Limit Check</b>	Enables limit checking associated with the pipe diameter values, orifice diameter values, and the beta ratio. The <b>default</b> is <b>On</b> ; select this field to disable limit checking.

7. Click in the hierarchy menu when you finish defining settings. A confirmation dialog box displays.
8. Click **Yes** to apply your changes. The PCSetup screen displays.

### 6.4.14 Stream Gas Composition

Stream Gas Composition settings define the processing and port telemetry parameters for streams receiving data from the gas chromatograph controller. The chromatograph controller measures the individual component concentrations found in the line gas. The chromatograph controller settings also allow you to define alarms. The system activates these alarms when the calculated results for the chromatograph data are not within specified limits.

1. Select **Gas Composition** from the hierarchy menu. The Gas Composition screen displays.

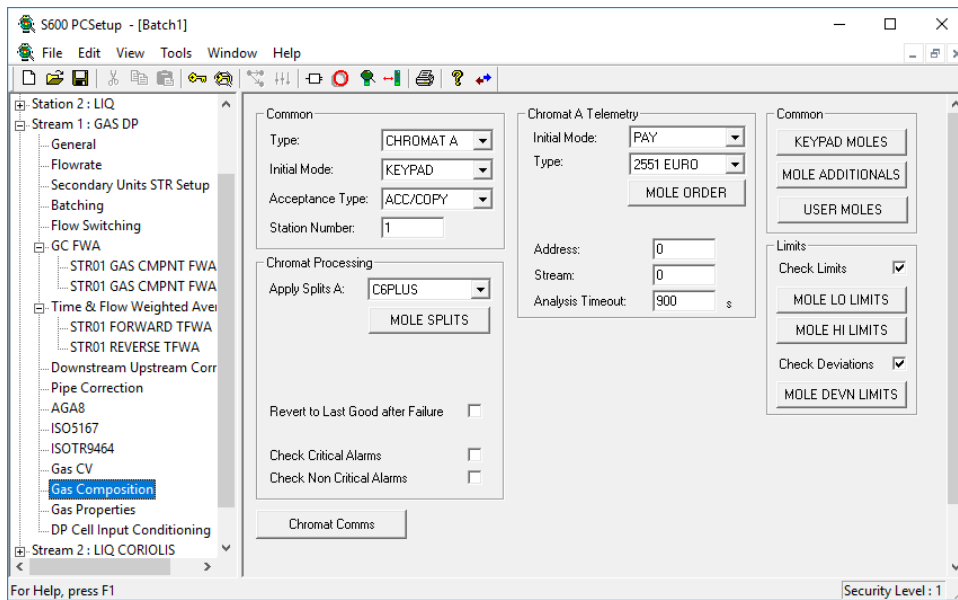

Figure 6-41. Gas Composition screen

2. Complete the following fields.

Field	Description
<b>Type</b>	Indicates the chromatograph configuration. Click ▼ to display all valid values.
<b>CHROMAT A</b>	Controller-connected; uses keypad data as fallback information.
<b>KP ONLY</b>	Not controller-connected; uses information entered via keypad. This is the <b>default</b> .
<b>Note:</b>	If you select <b>KP ONLY</b> , the system hides a number of fields on this screen.

Field	Description
<b>Initial Mode</b>	Indicates the operational mode for the in-use composition data. Click ▼ to display all valid values.
	<b>KEYPAD</b> Use data entered via keypad. This is the <b>default</b> .
	<b>CHROMAT</b> Use live data from the chromatograph controller.
	<b>DOWNLOAD</b> Download gas composition data directly to each stream. Used only if connected to a remote supervisory computer.
	<b>USER</b> Use customised program for gas composition in S600+.
	<b>KEYPAD_F</b> Start by using keypad-entered data then switch to chromatograph data when a good analysis is received.
<b>Acceptance Type</b>	Indicates how the S600+ manages in-use data. Click ▼ to display all valid values.
	<b>ACC/COPY</b> Copy and normalise keypad data to in-use data only after it is accepted. This is the <b>default</b> .
	<b>ACC/NORM</b> Copy normalised keypad data to in-use data after it is accepted.
	<b>AUTO/NORM</b> Automatically copy normalised keypad data to in-use data.
<b>Station Number</b>	Sets the station associated with this stream. The default is 1.
<b>Apply Splits</b>	Indicates the type of analyser connected to the S600+. For a C6+ analyser, use the C6Plus option. Click ▼ to display all valid values. The default is <b>NO SPLITS</b> . If you select any value other than <b>NO SPLITS</b> , the system displays the <b>MOLE SPLITS</b> button. Use it to define the specific percentage splits for the gases. <b>Note:</b> This field displays <b>only</b> if you select <b>CHROMAT A</b> as the chromatograph configuration type.
<b>MOLE SPLITS</b>	Click to display a Gas Composition dialog box you use to indicate the mole splits for hexane, heptane, octane, nonane, and decane. <b>Note:</b> This button displays <b>only</b> if you select any value other than <b>NO SPLITS</b> in the Apply Splits field.
<b>Revert to Last Good after Failure</b>	Continues using the last good composition in the event of failure. Otherwise the system reverts to keypad data.
<b>Check Critical Alarms</b>	Marks the received composition as failed if any critical alarm is set (such as the pre-amp fail on the Danalyzer for a Daniel 2551 Controller). <b>Note:</b> This field displays <b>only</b> if you select <b>CHROMAT A</b> as the chromatograph configuration type.
<b>Check Non Critical Alarms</b>	Marks the received composition as failed if any non-critical alarm is set (such as the pre-amp fail on the Danalyzer for a Daniel 2551 Controller). <b>Note:</b> This field displays <b>only</b> if you select <b>CHROMAT A</b> as the chromatograph configuration type.

Field	Description
<b>CHROMAT COMMS</b>	Click to display the Comm screen in I/O Setup (see <i>Chapter 4, Section 4.10</i> ).
<b>Initial Mode</b>	Identifies the chromatograph and any fallback controllers. Currently, the only valid value is <b>PAY</b> , which indicates one chromatograph and no fallback controller. <b>Note:</b> This field displays <b>only</b> if you select <b>CHROMAT A</b> as the chromatograph configuration type.
<b>Type</b>	Indicates the type of chromatograph controller. Click ▼ to display all valid values. <b>Note:</b> This field displays <b>only</b> if you select <b>CHROMAT A</b> as the chromatograph configuration type.
<b>2551 EURO</b>	S600+ is connected to a Daniel 2551 (European) controller. This is the <b>default</b> .
<b>2350 EURO</b>	S600+ is connected to a Daniel 2350 (European) controller set in SIM_2251 mode.
<b>2350 USA</b>	S600+ is connected to a Daniel 2350 (USA) controller set in SIM_2251 mode.
<b>2251 USA</b>	S600+ is connected to a Daniel 2251 controller.
<b>Generic</b>	S600+ is connected to another type of controller.
<b>Siemens</b>	S600+ is connected to a Siemens Advance Maxum via a Siemens Network Access Unit (NAU).
<b>MOLE ORDER</b>	Click this button to display a dialog box on which you indicate the order in which the gas composition information comes into the S600+ via telemetry. <b>0</b> indicates any component which is <b>not</b> included in the Modbus map. <b>Note:</b> <ul style="list-style-type: none"> <li>▪ The Modbus map you create must be compatible with the controller to which the S600+ is connected. Refer to <i>Chapter 14, Modbus Editor</i>, for further information.</li> <li>▪ This field displays <b>only</b> if you select <b>CHROMAT A</b> as the chromatograph configuration type.</li> <li>▪ This field is applicable <b>only</b> if you select <b>Siemens</b> or <b>Generic</b> in the Type field.</li> </ul>
<b>Address</b>	Configures multi-drop chromatograph support. <b>Do not change unless advised to do so.</b> <b>Note:</b> This field displays <b>only</b> if you select <b>CHROMAT A</b> as the chromatograph configuration type.
<b>Stream</b>	Sets the chromat analysis stream assigned to this metering stream. The default is <b>0</b> . <b>Note:</b> This field displays <b>only</b> if you select <b>CHROMAT A</b> as the chromatograph configuration type. If you need to support more than one stream, contact Technical Support.



<b>Field</b>	<b>Description</b>
<b>Analysis Timeout</b>	<p>Sets the maximum number of seconds the S600+ waits to receive a new composition from the chromatograph controller before raising an alarm. The default is <b>900</b>.</p> <p><b>Note:</b> This field displays <b>only</b> if you select <b>CHROMAT A</b> as the chromatograph configuration type.</p>
<b>Download Timeout</b>	<p>Sets the maximum number of minutes the S600+ waits to receive a new composition from the supervisory computer before raising a <b>DL Timeout Alarm</b>. The default is <b>15</b>.</p> <p><b>Note:</b></p> <ul style="list-style-type: none"> <li>▪ A value of <b>0</b> disables the timeout.</li> <li>▪ This field displays <b>only</b> if you select <b>KP ONLY</b> in the Common Type field.</li> </ul>
<b>KEYPAD MOLES</b>	<p>Click to display a dialog box you use to define mole percentage values for each gas component.</p> <p><b>Note:</b> The system assumes the keypad composition adds to 100% (normalised) when the Acceptance Type is ACC/COPY. If you select ACC/NORM or AUTO/NORM, the system automatically normalises the keypad composition.</p>
<b>MOLE ADDITIONAL</b>	<p>Click to display a dialog box you use to define mole percentage values for gas components not analysed by the Danalyzer. The system assumes any additional components to be normalised values, and the analyser components are re-normalized (100 – sum of additional components).</p> <p><b>Note:</b> This field displays <b>only</b> if you select <b>CHROMAT A</b> as the chromatograph configuration type.</p>
<b>USER MOLES</b>	<p>Click to display a dialog box you use to define mole percentage values for each gas component. The system assumes user moles to be normalised.</p> <p><b>Note:</b> The S600+ uses these values <b>only</b> if you set the Initial Mode to <b>USER</b>. A Modbus download from another computer may overwrite these values on a running configuration.</p>
<b>Check Limits</b>	<p>Enables limit checking on each gas component. When you select this check box, the <b>MOLE LO LIMITS</b> and <b>MOLE HI LIMITS</b> buttons display.</p>

Field	Description
<b>MOLE LO LIMITS</b>	<p>Click to display a dialog box you use to define low mole percentage limit values for each gas component. Enter <b>0</b> in any field to prevent the test for the selected component.</p> <p><b>Note:</b></p> <ul style="list-style-type: none"> <li>▪ The system uses the values you enter through these buttons <b>only</b> if you select the Check Limits check box. The system applies this test to the keypad, downloaded, user, additional, and new analysis components. When enabled, the system applies the limit check against the high and low limits. Limits are considered valid if the limit is greater than zero (0). The system also applies the check to the Total field. If you <b>disable</b> the limit check, the keypad, downloaded and user Total field must lie within 0.1% and 150%. A sum of the new analysis must be within 99.5% and 100.5%.</li> <li>▪ This field displays <b>only</b> if you place a check mark in the Check Limits field.</li> </ul>
<b>MOLE HI LIMITS</b>	<p>Click to display a dialog box you use to define high mole percentage limit values for each gas component. Enter <b>0</b> in any field to prevent the test for the selected component.</p> <p><b>Note:</b> See note in description of Mole Lo Limits field.</p>
<b>Check Deviations</b>	<p>Enables checking on the deviation from the last good analysis for each component. When you select this check box, the <b>MOLE DEVN LIMITS</b> button displays.</p> <p><b>Note:</b> This field displays <b>only</b> if you select <b>CHROMAT A</b> as the chromatograph configuration type.</p>
<b>MOLE DEVN LIMITS</b>	<p>Click to display a dialog box you use to define the maximum deviation allowed for each gas component. Enter <b>0</b> in any field to prevent the test for the selected component.</p> <p><b>Note:</b> This field displays <b>only</b> if you place a check mark in the Check Deviations field.</p>

3. Click in the hierarchy menu when you finish defining settings. A confirmation dialog box displays.
4. Click **Yes** to apply your changes. The PCSetup screen displays.

### 6.4.15 Z Steam (Compressibility)

This screen displays when you configure the S600+ to use the Steam standards to calculate flowing density and flowing enthalpy for steam.

The compressibility settings also allow you to define alarms. The system activates these alarms when the device calculates results that are not within the limits you configure.

---

**Note:** The S600+ only supports-mass based CV units

---

1. Select **Steam** from the hierarchy menu. The Z Steam screen displays.

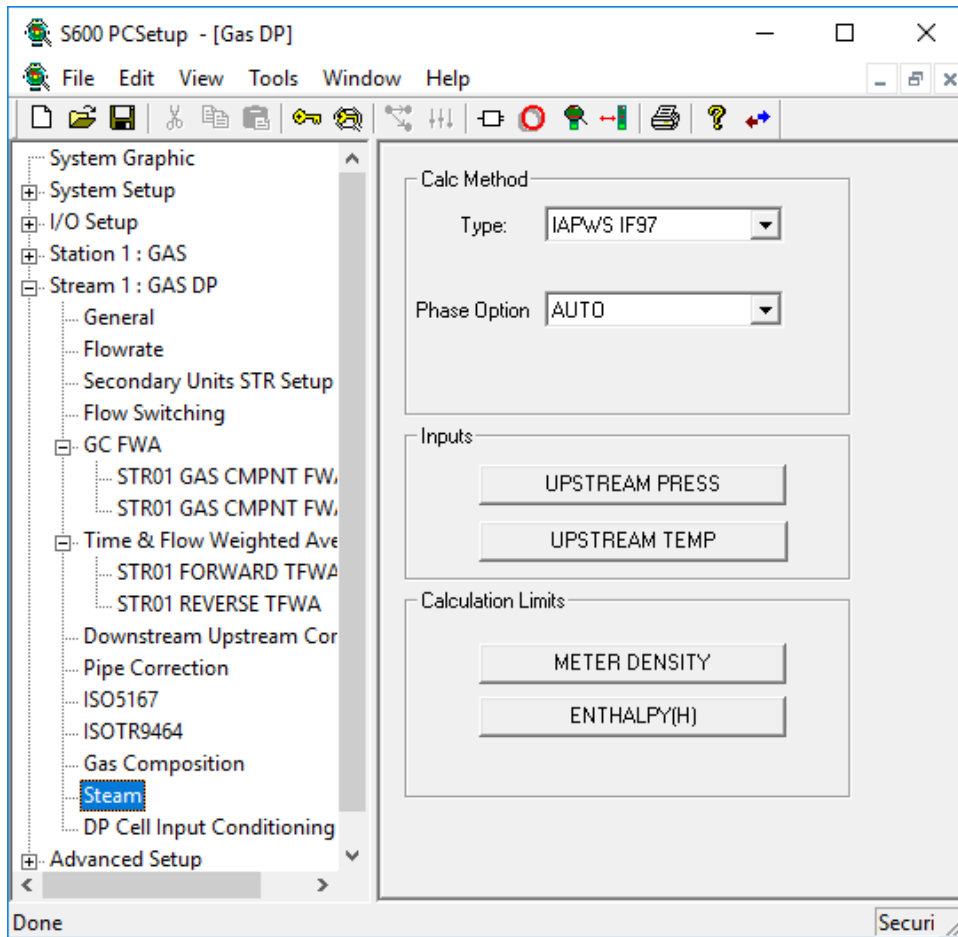

Figure 6-42. Z Steam (Compressibility) screen

2. Complete the following fields.

Field	Description
Type	Indicates the compressibility method. Click ▼ to display all valid values. Available calculation methods are <b>IFC 1967</b> and <b>IAPWS-IF97</b> .
Phase Option	Indicates the phase calculation method. Click ▼ to display all valid values. <b>Note:</b> This option is available <b>only</b> if you select <b>IAPWS-IF97</b> in the Type field.
<b>AUTO</b>	The S600+ automatically selects the region to use based on the temperature and pressure inputs. This is the <b>default</b> .
<b>STEAM</b>	The S600+ uses Region 2 for calculations and raises an alarm if this is not possible
<b>WATER</b>	The S600+ uses Region 1 for calculations and raises an alarm if this is not possible
<b>UPSTREAM PRESS</b>	Click to display a Calculation Result dialog box you use to define the mode, keypad value, and the specific alarm limits for upstream pressure.
<b>UPSTREAM TEMP</b>	Click to display a Calculation Result dialog box you use to define the mode, keypad value, and the specific alarm limits for upstream temperature.

Field	Description
<b>METER DENSITY</b>	Click to display a Calculation Result dialog box you use to define the mode, keypad value, and the specific alarm limits for the meter density.
<b>ENTHALPY(H)</b>	Click to display a Calculation Result dialog box you use to define the mode, keypad value, and the specific alarm limits for enthalpy(H).

3. Click in the hierarchy menu when you finish defining settings. A confirmation dialog box displays.
4. Click **Yes** to apply your changes. The PCSetup screen displays.

### 6.4.16 GOST CV

Calorific Value settings define the composition type, table to be used, and calculation limits for a range of parameters including density, relative density, and calorific value. This screen displays when you configure the S600+ to use the GOST 30319.1-96 Section 7 standards to calculate the calorific value (heating value) of the gas mixture.

The GOST CV settings also allow you to define alarms. The system activates these alarms when the calculated results for the chromatograph data are not within specified limits.

1. Select **Gost CV** from the hierarchy menu. The GOST CV screen displays.

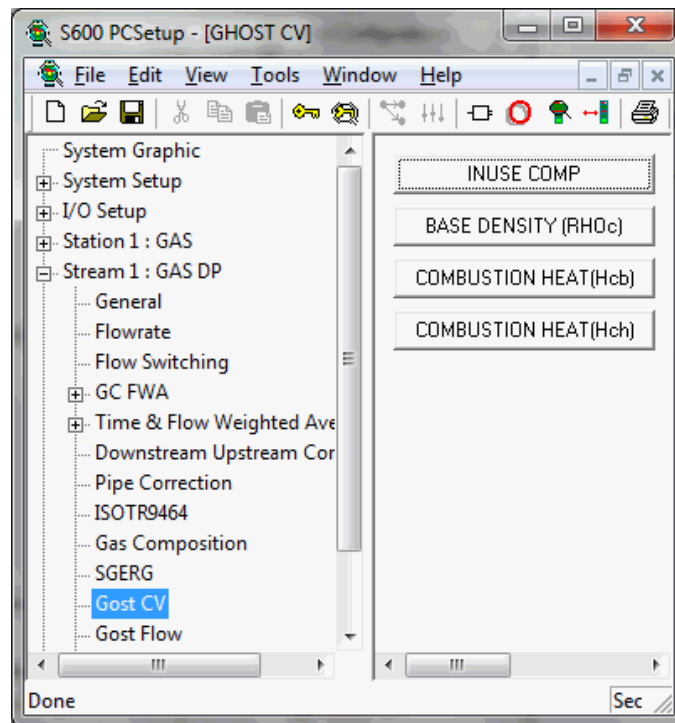

Figure 6-43. GOST CV screen

2. Click any of the following buttons to define GOST CV settings.

Button	Description
<b>INUSE COMP</b>	Click to display a dialog box you use to define the specific percentages for all components of the gas mixture.

Button	Description
<b>BASE DENSITY (RHOC)</b>	Click to display a Calculation Result dialog box you use to define the mode, keypad value, and the specific alarm limits for the base density.
<b>COMBUSTION HEAT (Hcb)</b>	Click to display a Calculation Result dialog box you use to define the mode, keypad value, and the specific alarm limits for superior CV. <b>Note:</b> This is the Superior Calorific value.
<b>COMBUSTION HEAT (Hch)</b>	Click to display a Calculation Result dialog box you use to define the mode, keypad value, and the specific alarm limits for inferior CV. <b>Note:</b> This is the Inferior Calorific value.

3. Click in the hierarchy menu when you finish defining settings. A confirmation dialog box displays.
4. Click **Yes** to apply your changes. The PCSetup screen displays.

### 6.4.17 GOST Flow

GOST flow settings define the constants and calculation limits for a range of parameters including pressure, density, flow coefficient, and pressure loss. This screen displays when you configure the S600+ to use the GOST 8563 standard to calculate gas flow through the orifice meter.

The GOST Flow settings also allow you to define alarms. The system activates these alarms when the calculated results are not within specified limits.

1. Select **Gost Flow** from the hierarchy menu. The GOST Flow screen displays.

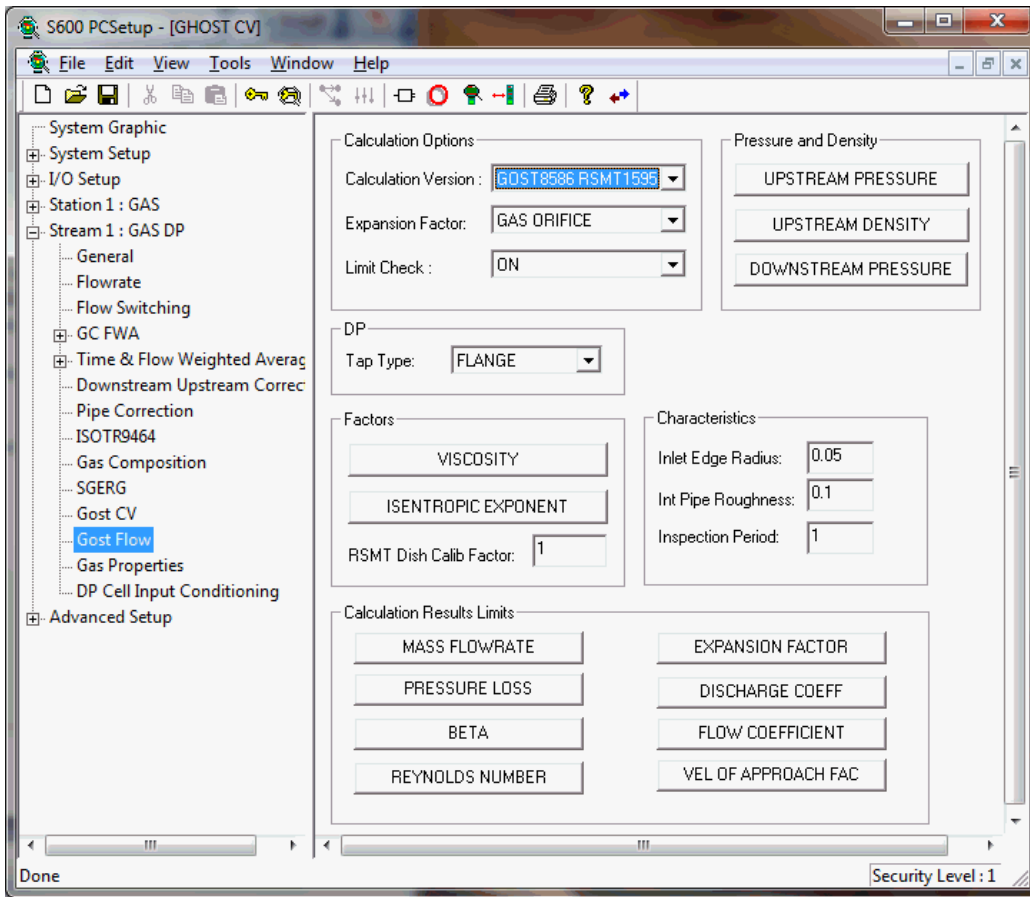

Figure 6-44. GOST Flow screen

2. Complete the following fields.

Field	Description
<b>Calculation Version</b>	Indicates the version of the GOST calculation the S600+ uses. Click ▼ to display all valid values. <b>GOST8586 05</b> The S600+ uses GOST 8.586-05 for the flow rate calculation. This is the <b>default</b> <b>GOST8563 97</b> The S600+ uses GOST 8.563.2-97 for the flow rate calculation <b>GOST8586 RSMT1595</b> The S600+ uses GOST 8.586-05 for the flow rate calculation with the specific discharge coefficient equations for the Rosemount 1595 Conditioning Orifice Plate
<b>Expansion Factor</b>	Displays options for calculating the fluid expansion factor. Click ▼ to display all valid versions. <b>GAS ORIFICE</b> Use the expansion factor formula as defined by calculation you select in the <b>Calculation Version</b> field. This is the <b>default</b> <b>LIQUID ORIFICE</b> Use an Expansion Factor = 1.0 (no expansion).
<b>Limit Check</b>	Activates calculation limit checking. Click ▼ to display all valid values. The default is <b>ON</b> . <b>Note:</b> If you activate limit checking, GOST validates the calculation inputs and outputs in accordance with section GOST 8.563.1 – 97.

Field	Description
Tap Type	Click ▼ to indicate the position of the differential pressure tap on the metering assembly. Possible options are FLANGE, CORNER, D-D/2, NOZZ 1932, NOZZ LR, VENT TUBE, VENT NOZZ. The default is <b>FLANGE</b> .
VISCOSITY	Click to display a Calculation Result dialog box you use to define the mode, keypad value, and the specific alarm limits for viscosity.
ISENTROPIC EXPONENT	Click to display a Calculation Result dialog box you use to define the mode, keypad value, and the specific alarm limits for the Isentropic exponent.
RSMT Dish Calib Factor	Indicates the discharge coefficient calibration factor added for the Rosemount 1595 conditioning orifice plate. <b>Note:</b> This field displays <b>only</b> if you select <b>RSMT1595-2003</b> as the Calculation Version.
Inlet Edge Radius	Sets the radius of the inlet edge. The default is <b>0.05</b> . <b>Note:</b> The program uses this value as part of the orifice dulling correction calculation.
Int Pipe Roughness	Sets the pipe roughness factor. The default is <b>0.01</b> . <b>Note:</b> The program uses this value as part of the roughness coefficient factor.
Inspection Period	Sets, in whole non-fractional years, the inspection period (or calibration span) for the inlet edge radius used in the calculation of the orifice dulling correction coefficient. The default is <b>1</b> . <b>Note:</b> You must enter a <b>whole</b> number. Fractions are not allowed.
UPSTREAM PRESSURE	Click to display a Calculation Result dialog box you use to define the mode, keypad value, and the specific alarm limits for upstream pressure.
UPSTREAM DENSITY	Click to display a Calculation Result dialog box you use to define the mode, keypad value, and the specific alarm limits for upstream density.
DOWNSTREAM PRESSURE	Click to display a Calculation Result dialog box you use to define the mode, keypad value, and the specific alarm limits for downstream pressure.

- Click any of the following buttons to define GOST flow calculation results limits.

Button	Description
MASS FLOWRATE	Click to display a Calculation Result dialog box you use to define the specific alarm limits for the mass flowrate.
PRESSURE LOSS	Click to display a Calculation Result dialog box you use to define the mode, keypad value, and the specific alarm limits for pressure loss.
BETA	Click to display a Calculation Result dialog box you use to define the specific alarm limits for the calculated diameter ratio.
REYNOLDS NUMBER	Click to display a Calculation Result dialog box you use to define the specific alarm limits for the Reynolds number.
EXPANSION FACTOR	Click to display a Calculation Result dialog box you use to define the mode, keypad value, and the specific alarm limits for the expansion factor.

Button	Description
<b>DISCHARGE COEFF</b>	Click to display a Calculation Result dialog box you use to define the specific alarm limits for the discharge coefficient.
<b>FLOW COEFFICIENT</b>	Click to display a Calculation Result dialog box you use to define the mode, keypad value, and the specific alarm limits for the flow coefficient.
<b>VEL OF APPROACH FAC</b>	Click to display a Calculation Result dialog box you use to define the specific alarm limits for the velocity of approach factor.

- Click in the hierarchy menu when you finish defining settings. A confirmation dialog box displays.
- Click **Yes** to apply your changes. The PCSetup screen displays.

### 6.4.18 Gas Properties

Gas properties settings define methods the system uses to calculate viscosity, isentropic exponent (also known as “specific heat ratio” or “adiabatic exponent”), and the velocity of sound.

These settings also allow you to define alarms. The system activates these alarms when the calculated results are not within the specified limits.

- Select **Gas Properties** from the hierarchy menu. The Gas Properties screen displays.

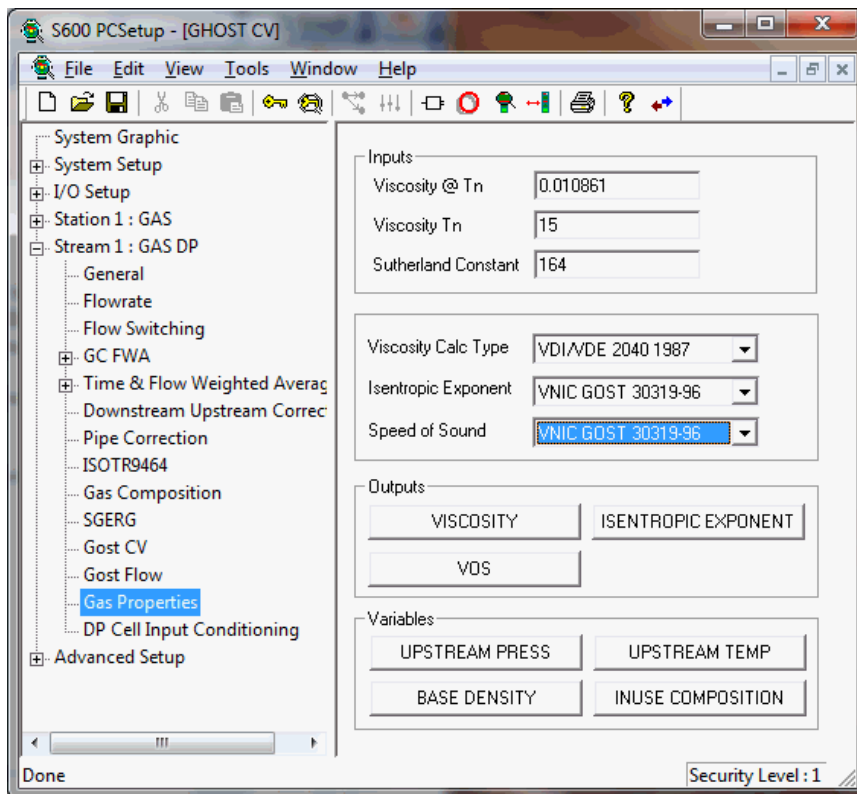

Figure 6-45. Gas Properties screen



2. Complete the following fields.

Field	Description										
<b>Viscosity @ Tn</b>	Sets the reference viscosity for the gas. The default is <b>0.010861</b> . <b>Note:</b> Used <b>only</b> by VDI/VDE.										
<b>Viscosity Tn</b>	Sets the reference viscosity temperature for the gas. The default is <b>15</b> . <b>Note</b> Used <b>only</b> by VDI/VDE.										
<b>Sutherland Constant</b>	Sets the Sutherland constant for the gas. The default is <b>164</b> . <b>Note</b> Used <b>only</b> by VDI/VDE.										
<b>Viscosity Calc Type</b>	Indicates the method for calculating the viscosity of the gas. Click ▼ to display all valid values. <table border="1" data-bbox="810 622 1450 1041"> <tbody> <tr> <td><b>Disabled</b></td> <td>Value not calculated; defaults to keypad-entered value. This is the <b>default</b></td> </tr> <tr> <td><b>SGERG GOST 30139-2015</b></td> <td>Uses calculations from GOST 30139-2015. Requires base density, N<sub>2</sub>, and CO<sub>2</sub> inputs.</td> </tr> <tr> <td><b>VDI/VDE 2040 1987</b></td> <td>Uses calculations from VDI/VDE 2040 Part 2 1987. Requires viscosity @T<sub>n</sub>, viscosity T<sub>n</sub>, and Sutherland Constant inputs.</td> </tr> <tr> <td><b>VNIC GOST 30319-2015</b></td> <td>Uses calculations from GOST 30319-2015. Requires full gas composition input.</td> </tr> </tbody> </table>	<b>Disabled</b>	Value not calculated; defaults to keypad-entered value. This is the <b>default</b>	<b>SGERG GOST 30139-2015</b>	Uses calculations from GOST 30139-2015. Requires base density, N <sub>2</sub> , and CO <sub>2</sub> inputs.	<b>VDI/VDE 2040 1987</b>	Uses calculations from VDI/VDE 2040 Part 2 1987. Requires viscosity @T <sub>n</sub> , viscosity T <sub>n</sub> , and Sutherland Constant inputs.	<b>VNIC GOST 30319-2015</b>	Uses calculations from GOST 30319-2015. Requires full gas composition input.		
<b>Disabled</b>	Value not calculated; defaults to keypad-entered value. This is the <b>default</b>										
<b>SGERG GOST 30139-2015</b>	Uses calculations from GOST 30139-2015. Requires base density, N <sub>2</sub> , and CO <sub>2</sub> inputs.										
<b>VDI/VDE 2040 1987</b>	Uses calculations from VDI/VDE 2040 Part 2 1987. Requires viscosity @T <sub>n</sub> , viscosity T <sub>n</sub> , and Sutherland Constant inputs.										
<b>VNIC GOST 30319-2015</b>	Uses calculations from GOST 30319-2015. Requires full gas composition input.										
<b>Isentropic Exponent</b>	Indicates the method for calculating the isentropic exponent of the gas. Click ▼ to display all valid values. <table border="1" data-bbox="810 1115 1450 1570"> <tbody> <tr> <td><b>AGA10 2003</b></td> <td>Uses calculations from AGA10 2003. Requires full gas composition input.</td> </tr> <tr> <td><b>Disabled</b></td> <td>Value not calculated; defaults to keypad-entered value. This is the <b>default</b></td> </tr> <tr> <td><b>GRI 1991</b></td> <td>Uses calculations from GRI 1991. Requires full gas composition input.</td> </tr> <tr> <td><b>SGERG GOST 30139-2015</b></td> <td>Uses calculations from GOST 30139-2015. Requires Base Density, N<sub>2</sub> and CO<sub>2</sub> inputs.</td> </tr> <tr> <td><b>VNIC GOST 30319-2015</b></td> <td>Uses calculations from GOST 30319-2015. Requires full gas composition input.</td> </tr> </tbody> </table>	<b>AGA10 2003</b>	Uses calculations from AGA10 2003. Requires full gas composition input.	<b>Disabled</b>	Value not calculated; defaults to keypad-entered value. This is the <b>default</b>	<b>GRI 1991</b>	Uses calculations from GRI 1991. Requires full gas composition input.	<b>SGERG GOST 30139-2015</b>	Uses calculations from GOST 30139-2015. Requires Base Density, N <sub>2</sub> and CO <sub>2</sub> inputs.	<b>VNIC GOST 30319-2015</b>	Uses calculations from GOST 30319-2015. Requires full gas composition input.
<b>AGA10 2003</b>	Uses calculations from AGA10 2003. Requires full gas composition input.										
<b>Disabled</b>	Value not calculated; defaults to keypad-entered value. This is the <b>default</b>										
<b>GRI 1991</b>	Uses calculations from GRI 1991. Requires full gas composition input.										
<b>SGERG GOST 30139-2015</b>	Uses calculations from GOST 30139-2015. Requires Base Density, N <sub>2</sub> and CO <sub>2</sub> inputs.										
<b>VNIC GOST 30319-2015</b>	Uses calculations from GOST 30319-2015. Requires full gas composition input.										

Field	Description
<b>Speed of Sound</b>	Indicates the method for calculating the speed of sound. Click ▼ to display all valid values.
	<b>AGA10 2003</b> Uses calculations from AGA10 2003. Requires full gas composition input.
	<b>Disabled</b> Value not calculated; defaults to keypad-entered value. This is the <b>default</b>
	<b>GRI 1991</b> Uses calculations from GRI 1991. Requires full gas composition input.
	<b>SGERG GOST 30139-2015</b> Uses calculations from GOST 30139-2015. Requires Base Density, N <sub>2</sub> and CO <sub>2</sub> inputs.
	<b>VNIC GOST 30319-2015</b> Uses calculations from GOST 30319-2015. Requires full gas composition input.

3. Click any of the following buttons to set gas property outputs or variables.

Button	Description
<b>VISCOSITY</b>	Click to display a Calculation Result dialog box you use to define the mode, keypad value, and the specific alarm limits for viscosity.
<b>VOS</b>	Click to display a Calculation Result dialog box you use to define the mode, keypad value, and the specific alarm limits for the velocity of sound (VOS).
<b>ISENTROPIC EXPONENT</b>	Click to display a Calculation Result dialog box you use to define the mode, keypad value, and the specific alarm limits for the isentropic exponent.
<b>UPSTREAM PRESS</b>	Click to display a Calculation Result dialog box you use to define the mode, keypad value, and the specific alarm limits for upstream pressure. <b>Note:</b> This button may be disabled on some applications.
<b>BASE DENSITY</b>	Click to display a Calculation Result dialog box you use to define the mode, keypad value, and the specific alarm limits for base density.
<b>UPSTREAM TEMP</b>	Click to display a Calculation Result dialog box you use to define the mode, keypad value, and the specific alarm limits for upstream temperature. <b>Note:</b> This button may be disabled on some applications.
<b>INUSE COMPOSITION</b>	Click to display a <b>read-only</b> table of gas compositions. This corresponds to the table defined using the Gas Composition screen's <b>KEYPAD MOLES</b> button.

4. Click in the hierarchy menu when you finish defining settings. A confirmation dialog box displays.
5. Click **Yes** to apply your changes. The PCSetup screen displays.

## 6.4.19 DP Cell Input Conditioning

Differential pressure (or DP) Cell Input Conditioning settings define how the S600+ sequences (or “stacks”) input cell information and sets calculation limits for differential pressure measurements.

These settings also allow you to define alarms. The system activates these alarms when the calculated results are not within the specified limits.

**Cell Input Stacking** The Stack Type you select on the DP Cell Input Conditioning screen (see *Figure 6-68*) defines how the S600+ sequences (or “stacks”) differential pressure values. DP stack handling enables you to mark each input cell as available under either of the following conditions:

- **Not available** when the value is under-range, over-range, in Keypad mode, or in a Failed mode (for example, Keypad-F).
- **Available** when the value is within the low and high fail limits of the analog input or in Measured mode.

The S600+ determines the value to use based on the stack types you select, which include:

- Single
- Lo-Hi
- Hi Hi
- Lo Mid Hi
- Lo Hi Hi
- 3 Identical

The switch up / switch down percentages are always calculated based on the cell scaling - irrespective of any analogue conversion selection that has been configured.

Additionally, enhanced error checking (an option you also select on the DP Cell Input Conditioning screen) provides another stacking criteria.

---

**Note:** If you select Imperial units, enhanced error checking is **disabled** by default. If you select metric units, enhanced error checking is **enabled** by default.

---

The stack type, along with enhanced error checking, result in the following.

**Single** Select **Single** when you connect to only a single input cell. This is the default input stack value.

- If you **enable** enhanced error checking and the input cell is available, the S600+ uses its value. If the cell is unavailable, the S600+ uses the value you define in the DP Keypad field.
- If you **disable** enhanced error checking, the S600+ uses the single cell’s In-Use value, regardless of operating mode, low or high fail limits, or whether the input cell is available.

**Lo-Hi** Select **Lo Hi** when you connect two cells in a tier.

- If you **enable** enhanced error checking, the S600+ first checks both cells to ensure they are either within the low and high fail limits of the analog input or in Measured mode. It then proceeds to perform cell selection.

The cell selector compares the DP values returned from both cells and changes range when one of the following occurs:

- When using the Lo Cell, the DP value returned from the Lo Cell is **greater than** the switch up percentage of the Lo Cell range.
- When using the Hi Cell, the DP value returned from the Hi Cell is **less than** the switch down percentage of the Lo Cell range.

To avoid too much switching between ranges, define switch-up and switch-down percentage values using the Up and Down fields in the DP Cell Input Condition screen’s Switching Points pane. The S600+ uses the difference between the switch-up and switch-down percentage as hysteresis. The normal value used is 5% hysteresis.

For example, the Lo Cell = 0–250 mbar and the Hi Cell = 0–500 mbar. If you define a Up value of **95** and a Down value of **90**, then the difference is 5%.

If the low range is in use and the differential pressure is rising, the S600+ continues to use this range until it reaches point A (237.5 mbar). At that point, the S600+ switches to the high range, point B (see *Figure 6-46*).

If the high range is in use and the differential pressure is falling, the S600+ continues to use this range until it reaches point C (225.0 mbar). At that point, the S600+ switches to the low range, point D (see *Figure 6-46*).

*Figure 6-47* provides a flowchart of Lo Hi input cell handling.

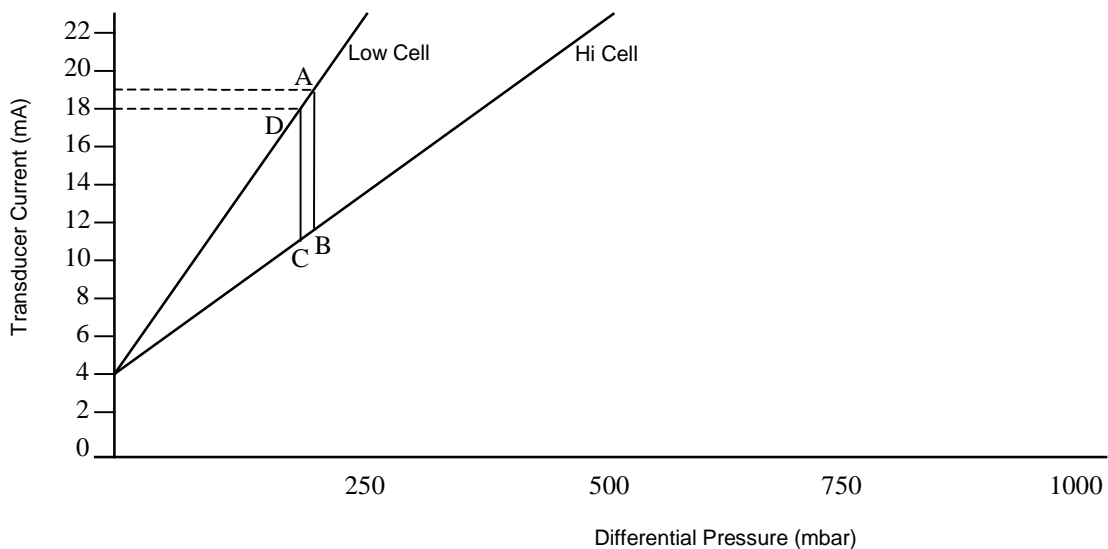

*Figure 6-46. Lo Hi Cell Input Handling*

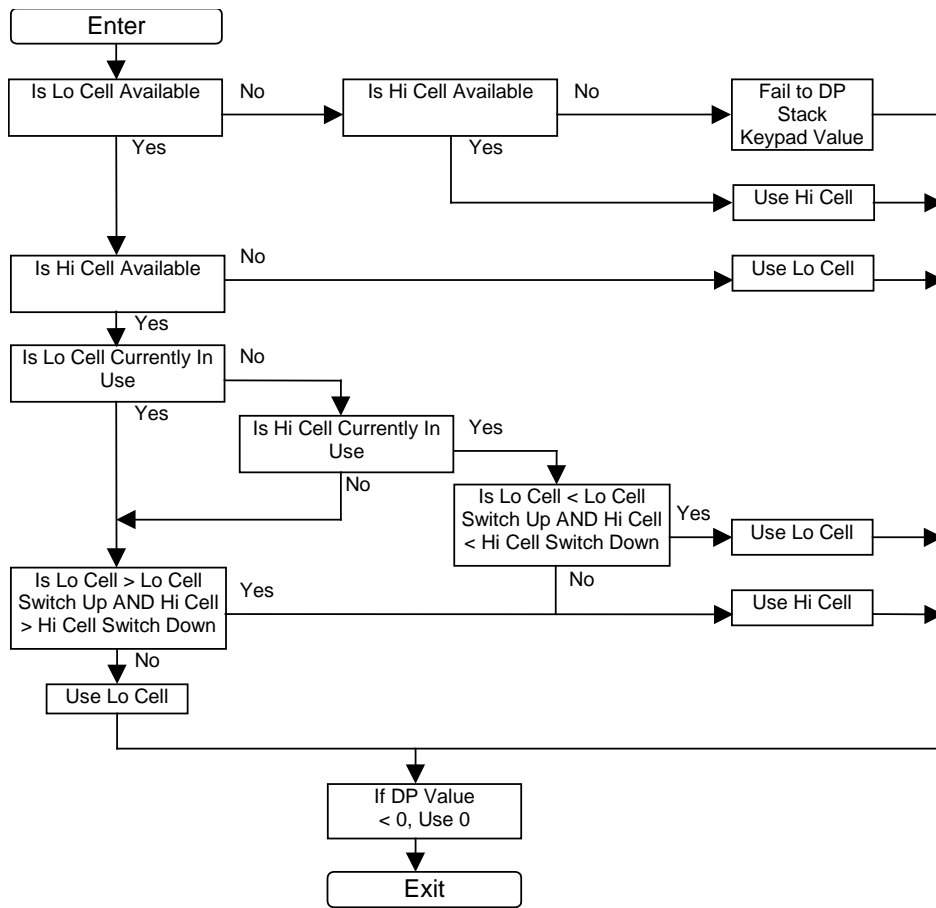

Figure 6-47. Lo Hi Cell Input Handling Flowchart

- If you **disable** enhanced error checking, the S600+ automatically uses the value of the In-Use cell (the one currently selected by the switch-up or switch-down criterion). The switch-up and switch-down points are based on the lower of the two available cells. The cells are always available for selection, regardless of their operating mode.

For example, if cell 1 is above its switch-up point, the stack switches up to cell 2, regardless of cell 2’s value.

**Hi-Hi** Select **Hi Hi** when you connect two cells, both of which are ranged to the same values and working in Duty-Standby mode. S600+ designates the cell currently being used as the “In Use” cell.

- If you **enable** enhanced error checking, the S600+ first checks both cells to ensure they are within the low and high fail limits of the analog input or in Measured mode and that there are no discrepancies between the Hi(1) and Hi(2) cells.
  - If the Hi(1) range is in use, the S600+ continues to use the Hi(1) range unless it becomes unavailable. At that point, the S600+ switches to the Hi(2) cell.
  - If the Hi(2) range is in use, the S600+ continue to use the Hi(2) range unless it becomes unavailable. At that point, the S600+switches to the Hi(1) cell.
  - If neither cell is available, the S600+ uses the defined DP Stack Keypad value and raises an alarm.

- If you **disable** enhanced error checking, the S600+ uses the selected cell's In-Use value, regardless of operating mode or low or high fail limits.

Figure 6-48 shows Hi Hi cell handling.

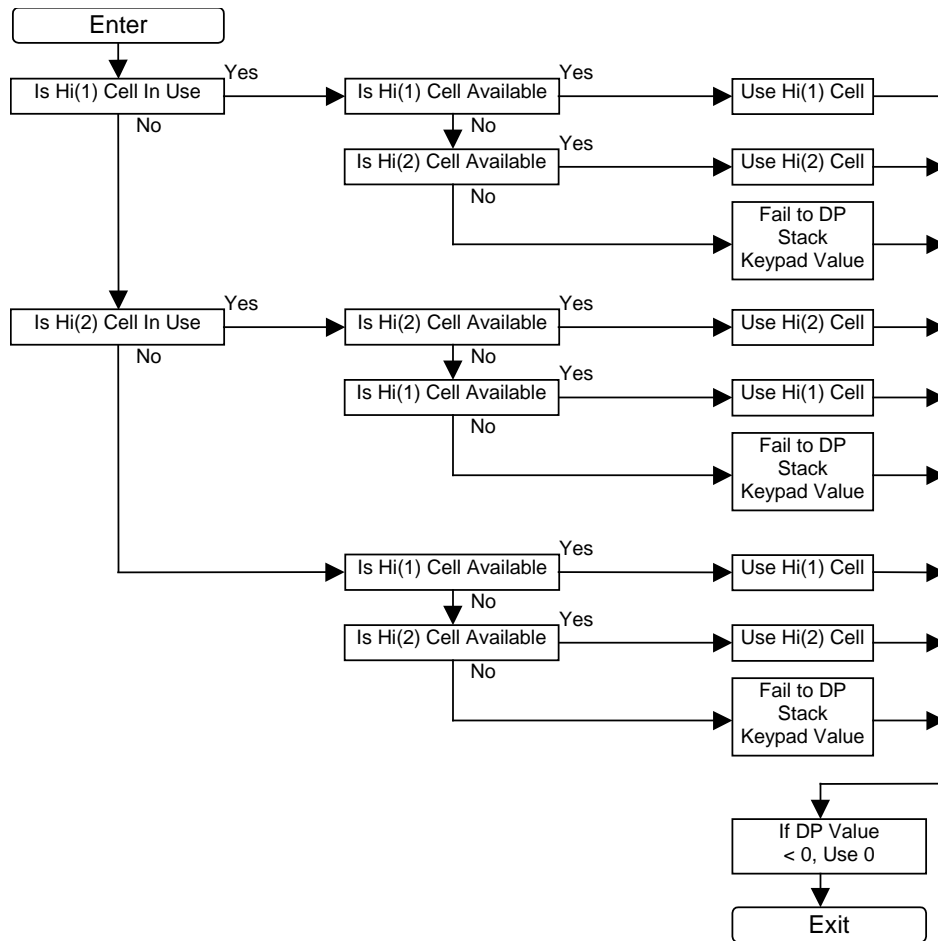

Figure 6-48. Hi Hi Cell Input Handling Flowchart

**Lo-Mid-Hi Cell** Select **Lo Mid Hi** when you connect three cells in a tier.

- If you **enable** enhanced error checking, the S600+ designates the cell currently being used as the “In Use” cell. The S600+ also checks for sustained discrepancies between:
  - Lo Cell and Mid Cell
  - Lo Cell and Hi Cell
  - Mid Cell and Hi Cell.

The cell selector compares the DP values returned from all three cells and changes range when one of the following occurs:

- When using the Lo Cell, the DP value returned from the Lo Cell is **greater than** the switch up percentage of the Lo Cell range.
- When using the Mid Cell, the DP value returned from the Mid Cell is **greater than** the switch up percentage of the Mid Cell range.

- When using the Mid Cell, the DP value returned from the Mid Cell is **less than** the switch down percentage of the Lo Cell range.
- When using the Hi Cell, the DP value returned from the Hi Cell is **less than** the switch down percentage of the Mid Cell range.

To avoid too much switching between ranges, define switch up and switch down percentage values using the Up and Down fields in the DP Cell Input Condition screen's Switching Points pane. The S600+ uses the difference between the switch up and switch down percentage as hysteresis. The normal value used is 5% hysteresis.

For example, the Lo Cell = 0–250 mbar and the Hi Cell = 0–500 mbar. If you define an Up value of **95** and a Down value of **90**, then the difference is 5%.

See *Figure 6-49* for a graphical presentation of the following usage situation.

If the **low range** is in use and the differential pressure is **rising**, the S600+ continues to use this range until it reaches point A (237.5 mbar). At that point, the S600+ switches to the mid range, point B.

If the **mid range** is in use and the differential pressure is **still rising**, the S600+ continues to use this range until it reaches point E (475.0 mbar). At that point, the S600+ switches to the high range, point F.

If the **high range** is in use and the differential pressure is **falling**, the S600+ continues to use this range until it reaches point H (450.0 mbar). At that point, the S600+ switches to the mid range, point G.

If the **mid range** is in use and the differential pressure is **still falling**, the S600+ continues to use this range until it reaches point C (225.0 mbar). At that point, the S600+ switches to the low range, point D.

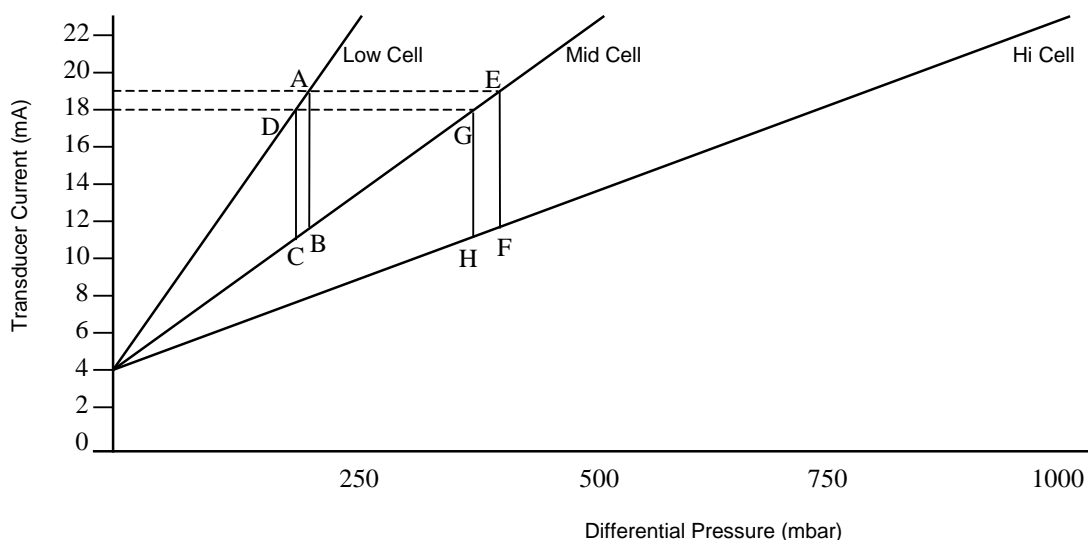

*Figure 6-49. Lo Mid Hi Cell Input Handling*

Figure 6-50 through Figure 6-53 provide flowcharts showing how the S600+ handles this.

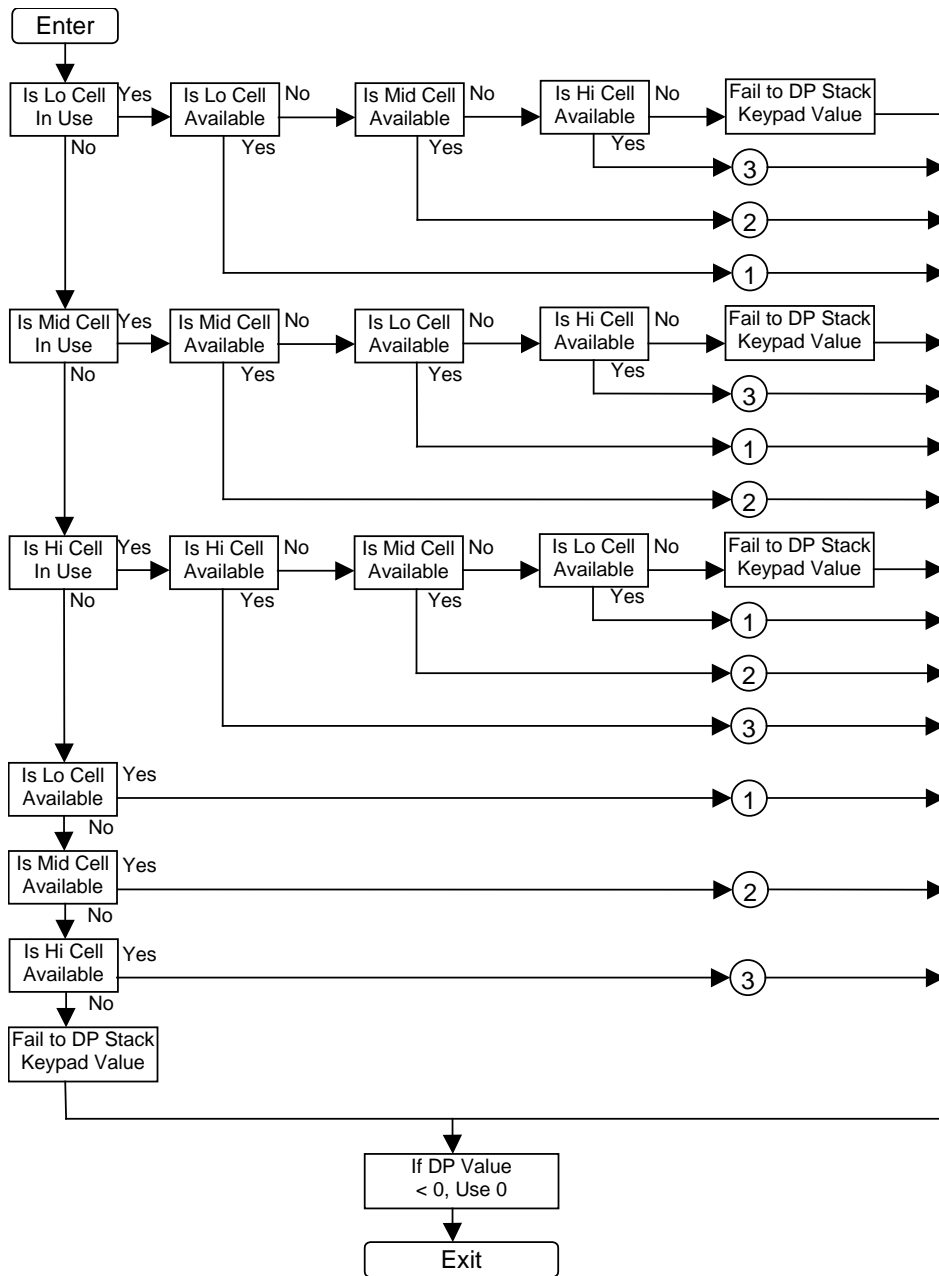

Figure 6-50. Lo Mid Hi Cell Input Handling Flowchart (1)



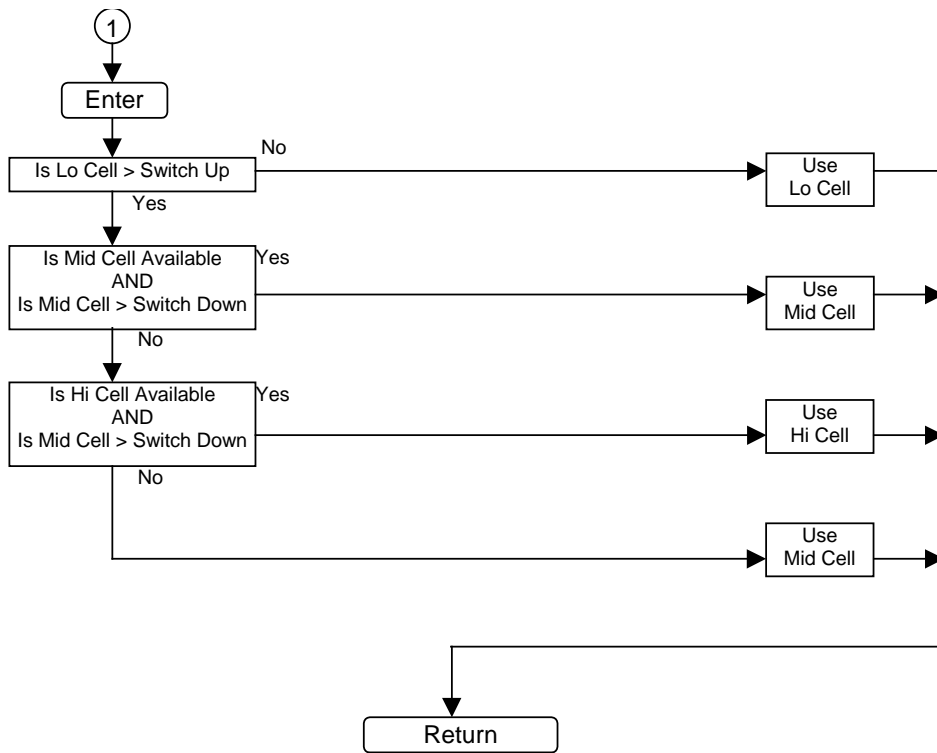

Figure 6-51. Lo Mid Hi Cell Input Handling Flowchart (2)

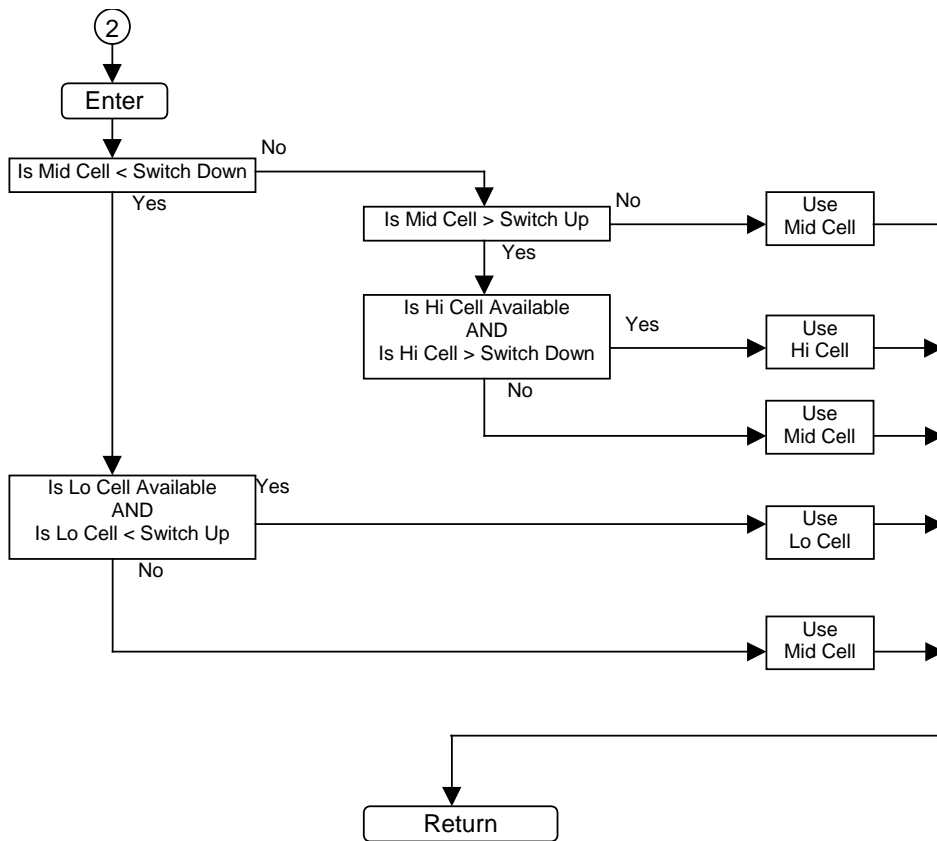

Figure 6-52. Lo Mid Hi Cell Input Handling Flowchart (3)

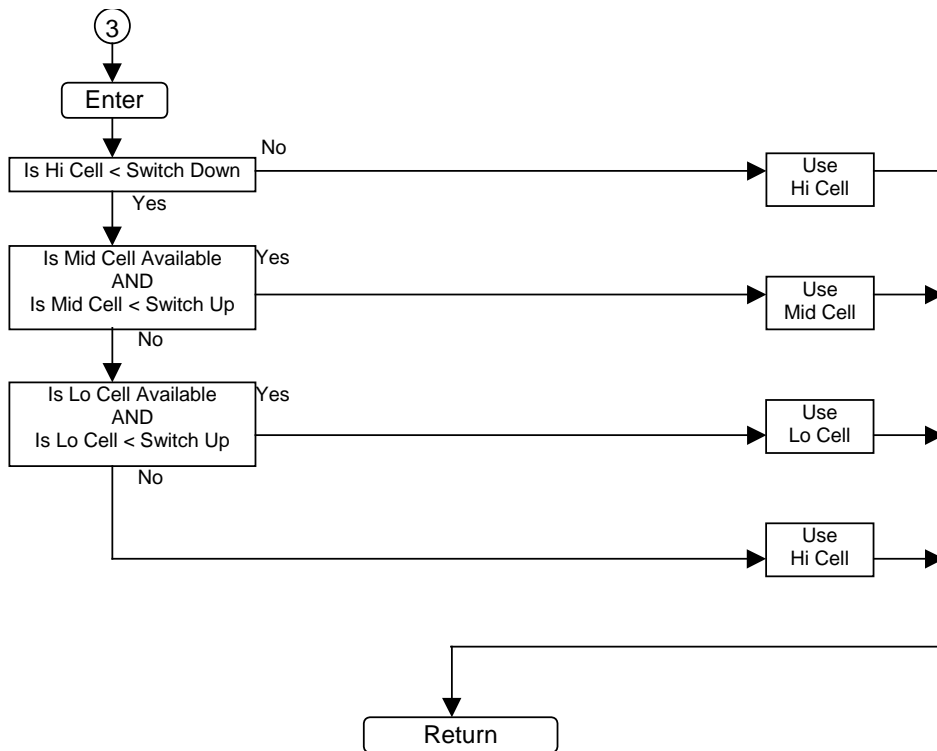

Figure 6-53. Lo Mid Hi Cell Input Handling Flowchart (4)

- If you **disable** enhanced error checking, the S600+ automatically uses the value of the In-Use cell (the one currently selected by the switch-up or switch-down criterion). The switch-up and switch-down points are based on the lowest of the three available cells. The cells are always available for selection, regardless of their operating mode.

For example, if cell 2 is above its switch-up point, the stack switches up to cell 3, regardless of the value of cell 3.

**Lo-Hi-Hi** Select **Lo Hi Hi** when you connect three cells, two of which are ranged to the same value and work in a tier, but the Hi cells are working in Duty-Standby mode. S600+ designates the cell currently being used as the “In Use” cell. The S600+ also checks for sustained discrepancies between the Lo cell and the Hi(1) cell, the Lo cell and the Hi(2) cell, and the Hi(1) cell and the Hi(2) cell.

- If you **enable** enhanced error checking, the cells must be within the low and high fail limits of the analog input or in Measured mode.
- If you **disable** enhanced error checking, the S600+ automatically uses the value of the In-Use cell (the cell currently selected by the switch-up or switch-down criterion). The switch-up and switch-down points are based on the lowest of the three available cells. The cells are always available for selection, regardless of the low and high fail limits and their operating mode.

The cell selector compares the DP values returned from all three cells and changes range when one of the following occurs:

- When using the Lo Cell, the DP value returned from the Lo Cell is **greater than** the switch-up percentage of the Lo Cell range.

- When using the Hi(1) Cell, the DP value returned from the Hi(1) Cell is **less than** the switch-down percentage of the Lo Cell range.
- When using the Hi(2) Cell, the DP value returned from the Hi(2) Cell is **less than** the switch-down percentage of the Lo Cell range.
- When using the Lo Cell, the cell becomes unavailable.
- When using the Hi(1) Cell, the cell becomes unavailable.
- When using the Hi(2) Cell, the cell becomes unavailable.

To avoid too much switching between ranges, define switch-up and switch-down percentage values using the Up and Down fields in the DP Cell Input Conditioning screen's Switching Points pane. The S600+ uses the difference between the switch-up and switch-down percentage as hysteresis. The normal value used is 5% hysteresis.

For example, the Lo Cell = 0–250 mbar and the Hi Cell = 0–500 mbar. If you define a Up value of **95** and a Down value of **90**, then the difference is 5%.

See *Figure 6-54* for a graphical presentation of the following usage situation.

If the **low range** is in use and the differential pressure is **rising**, the S600+ continues to use this range until it reaches point A (237.5 mbar). At that point, the S600+ switches to the Hi(1) or Hi(2) range, point B.

If the Hi(1) or Hi(2) range is in use and the differential pressure is **still falling**, the S600+ continues to use this range until it reaches point C (225.0 mbar). At that point, the S600+ switches to the low range, point D.

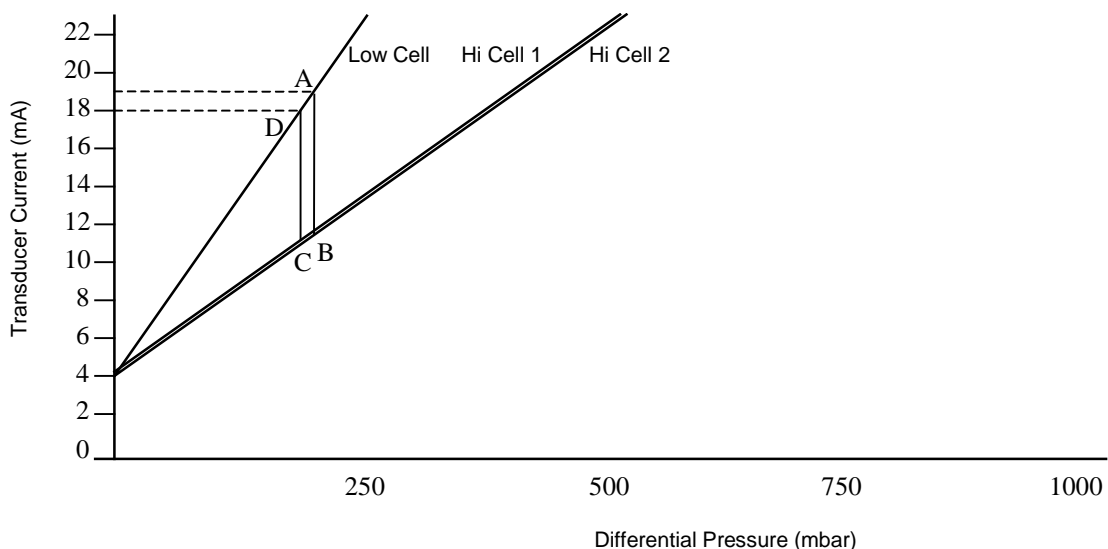

*Figure 6-54. Lo Hi Hi Cell Input Handling*

*Figure 6-55 through Figure 6-58* provide flowcharts illustrating how the S600+ handles this.

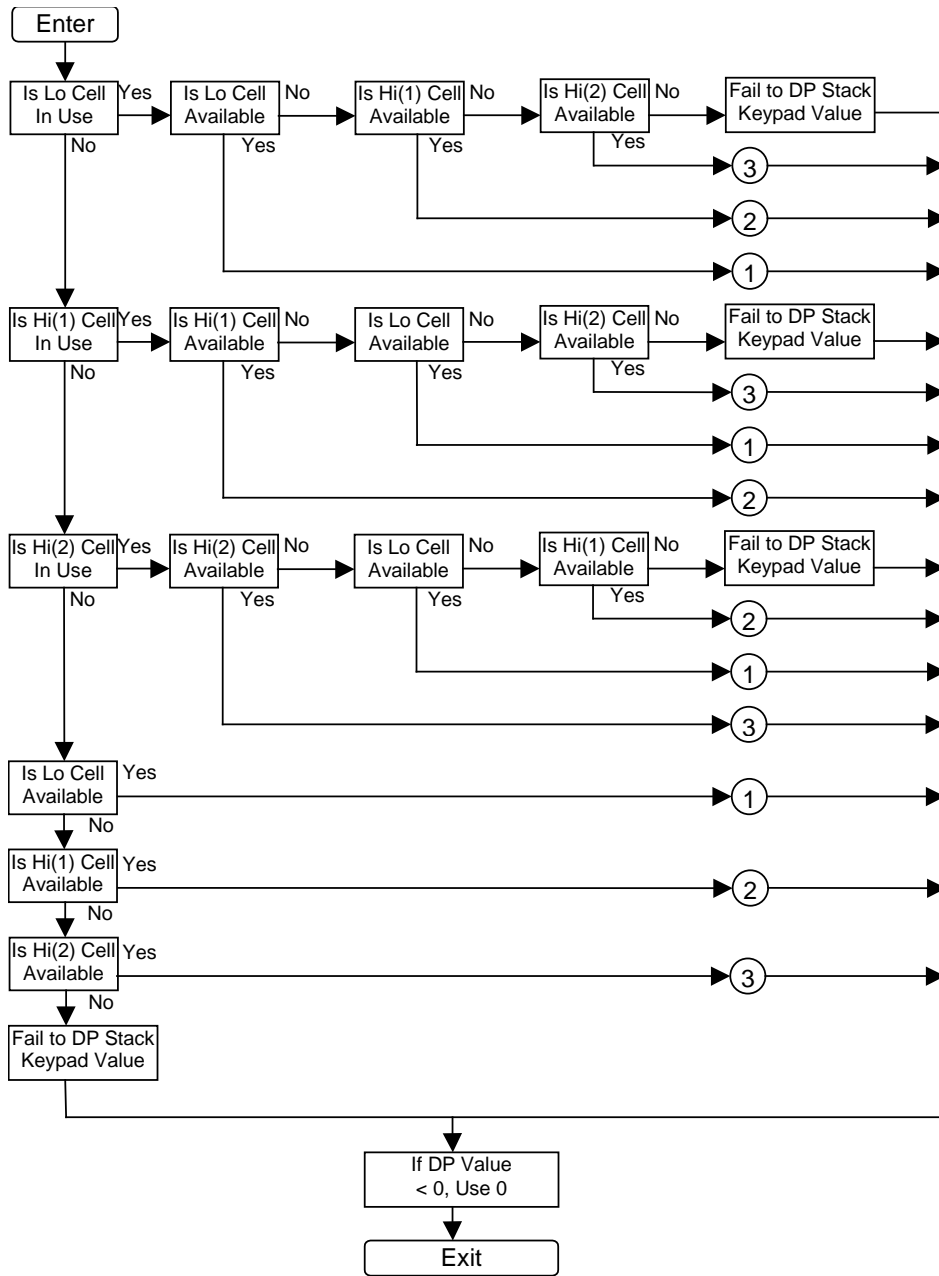

Figure 6-55. Lo Hi Hi Cell Input Handling Flowchart (1)

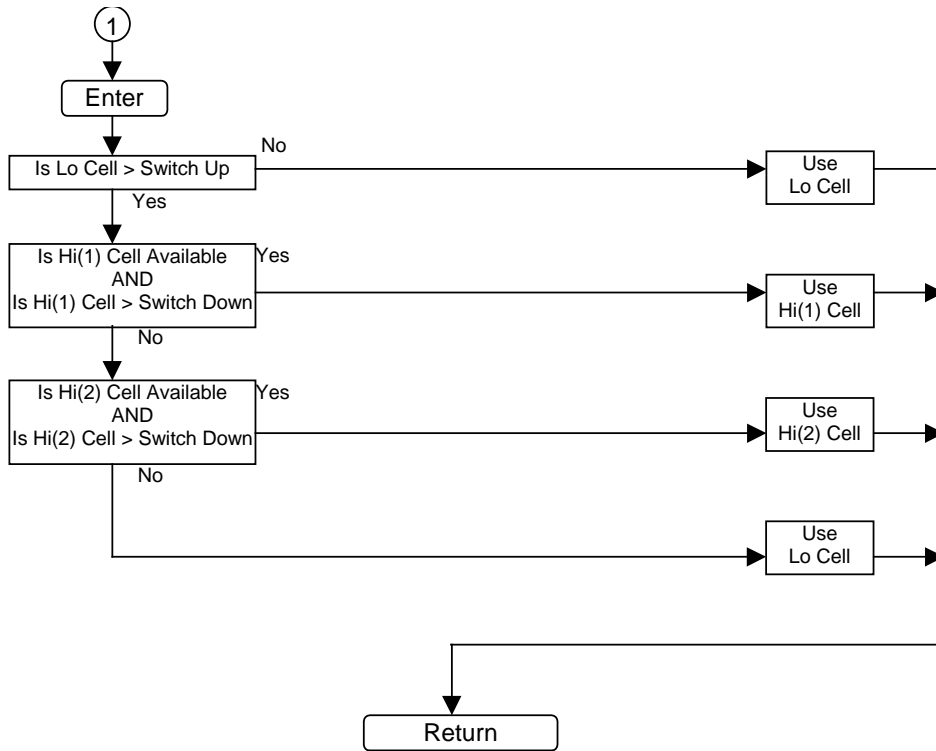

Figure 6-56. Lo Hi Hi Cell Input Handling Flowchart (2)

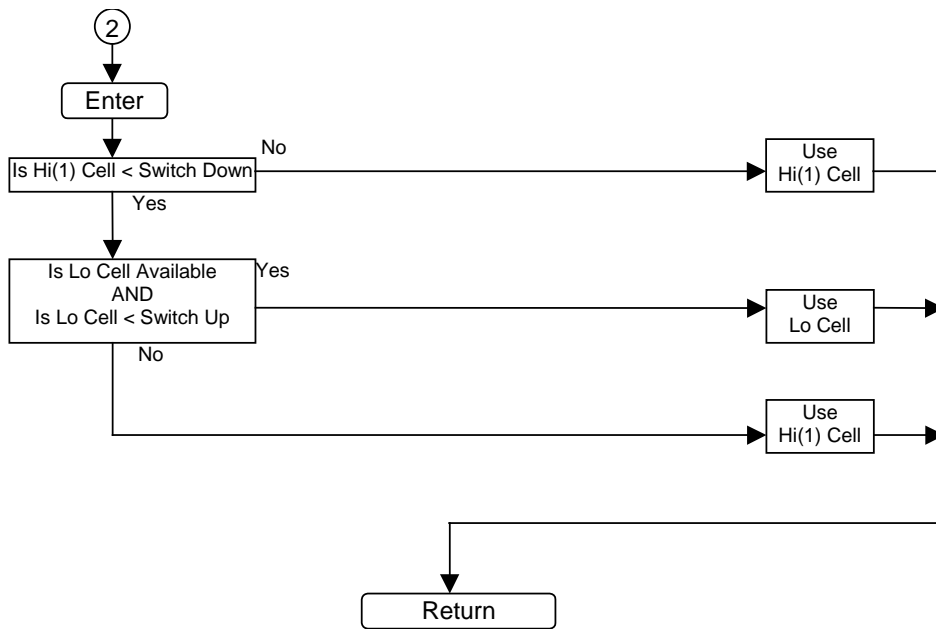

Figure 6-57. Lo Hi Hi Cell Input Handling Flowchart (3)

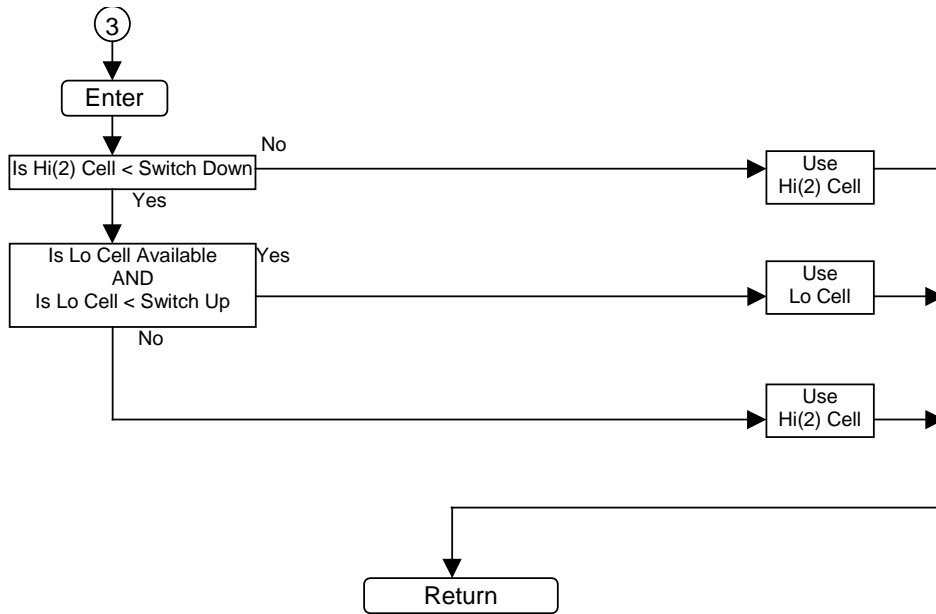

Figure 6-58. Lo Hi Hi Cell Input Handling Flowchart (4)

**3 Identical** The **3 Identical** cell arrangement uses a voting scheme to select which cells are to be averaged to yield the stack’s DP value.

---

**Note:** The mode is supported **only** when you **enable** enhanced error checking.

---

If all three cells are available, the S600+ uses the instantaneous results from discrepancy checking to determine which cells are within tolerance of each other (where “=” means “within discrepancy limits” and “≠” means “not within discrepancy limits”):

- If all are **within tolerance**, then use the **average** of the three.
- If only two cells are outside tolerance (for example, cell1 = cell2, cell1 = cell3, cell2 ≠ cell3), then choose the pair with the smallest difference and take their average.
- If only two cells are within tolerance (for example, cell1 = cell2, cell1 ≠ cell3, cell2 ≠ cell3), then choose this pair and take their average.
- If all three cells are outside the discrepancy limits, select the middle cell.
- If only two cells are available, then take their average.
- If only one cell is available, then use it.

Figure 6-59 through Figure 6-67 provide flowcharts showing how the S600+ handles this scheme.

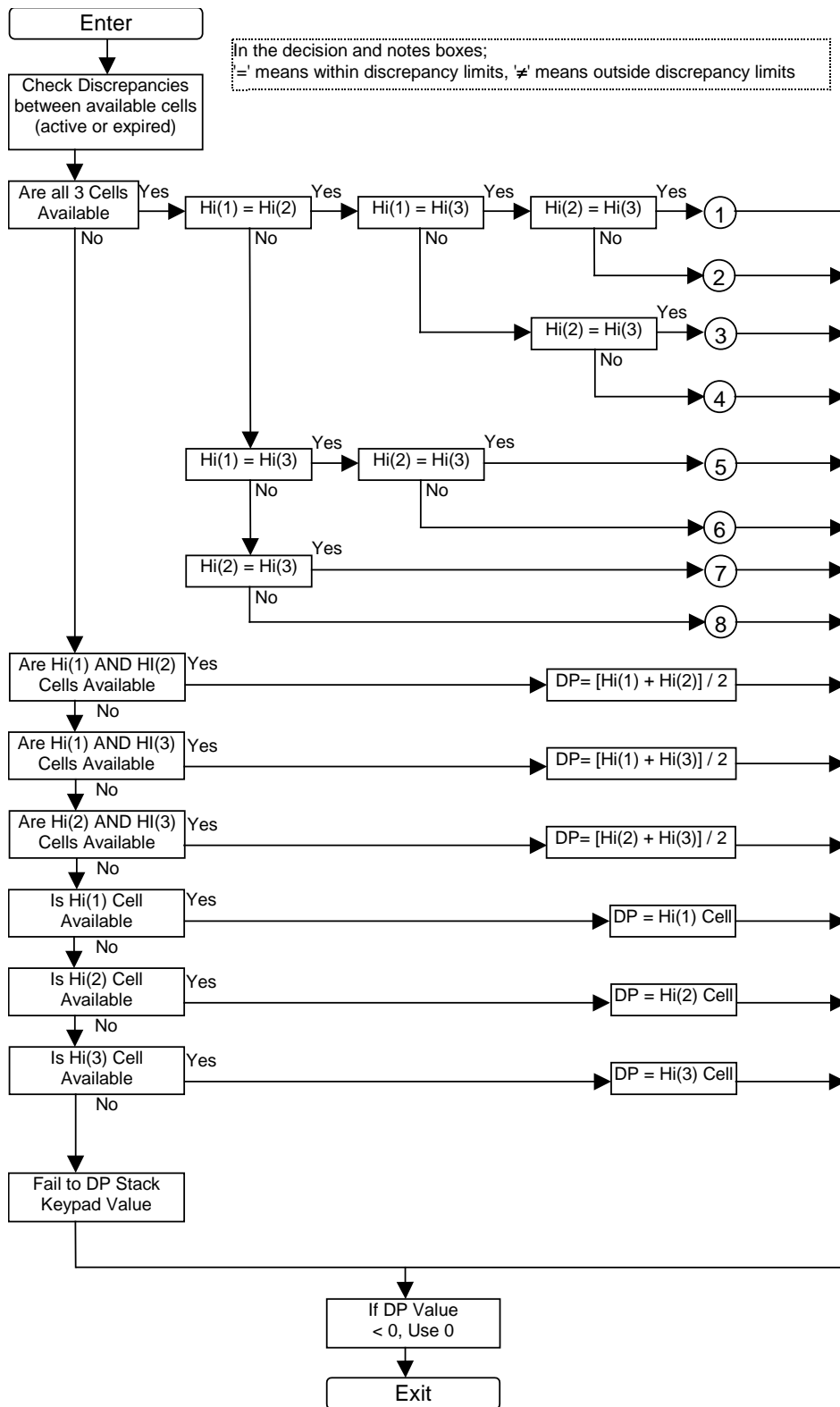

Figure 6-59. 3 Identical Cell Input Handling Flowchart (1)

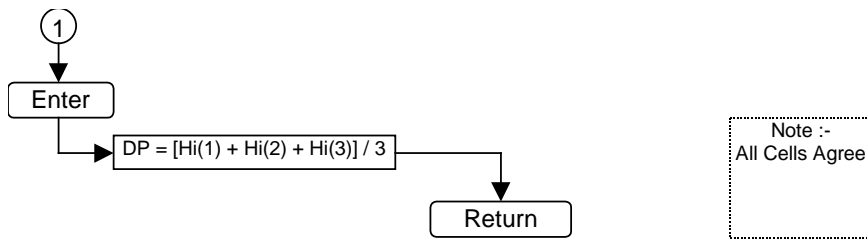

Figure 6-60. 3 Identical Cell Input Handling Flowchart (2)

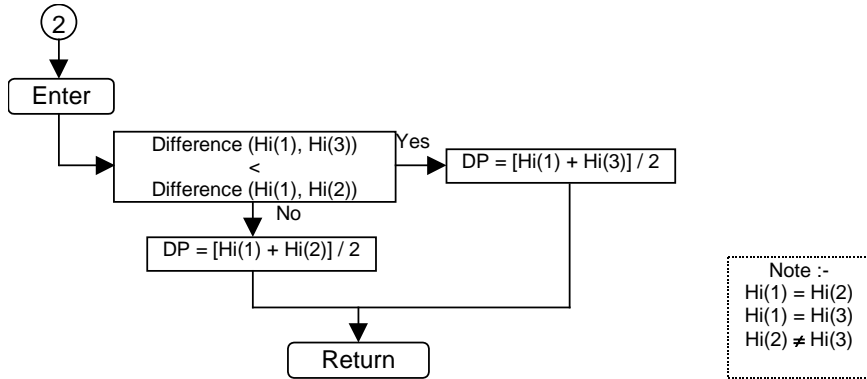

Figure 6-61. 3 Identical Cell Input Handling Flowchart (3)

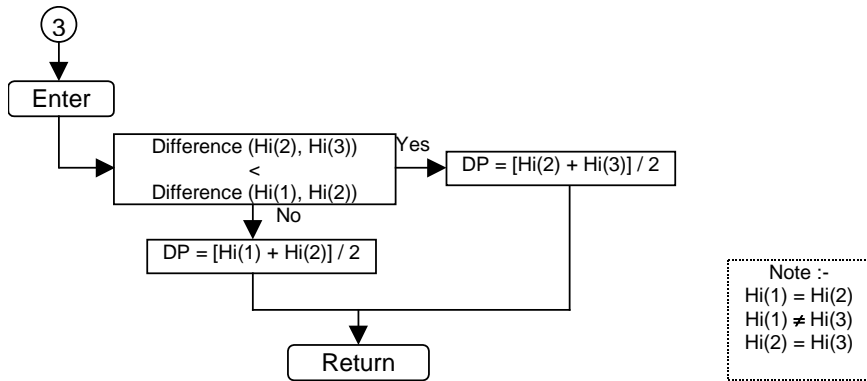

Figure 6-62. 3 Identical Cell Input Handling Flowchart (4)

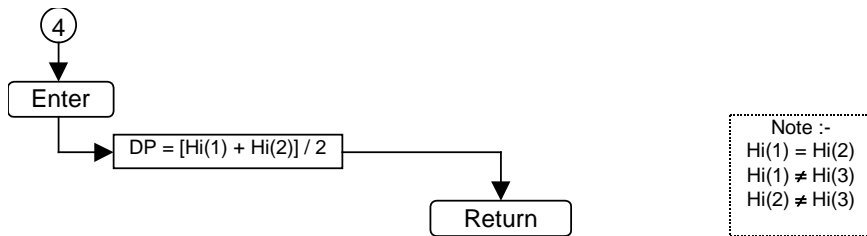

Figure 6-63. 3 Identical Cell Input Handling Flowchart (5)



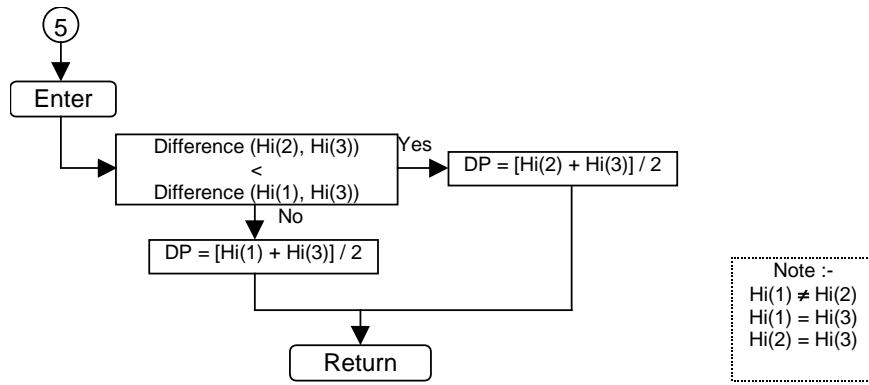

Figure 6-64. 3 Identical Cell Input Handling Flowchart (6)

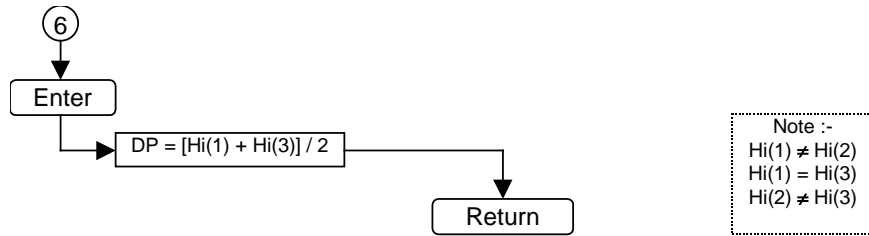

Figure 6-65. 3 Identical Cell Input Handling Flowchart (7)

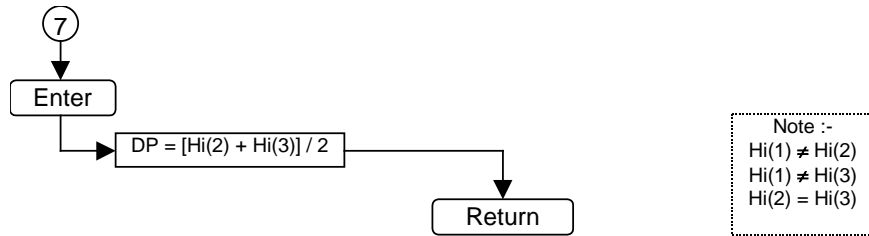

Figure 6-66. 3 Identical Cell Input Handling Flowchart (8)

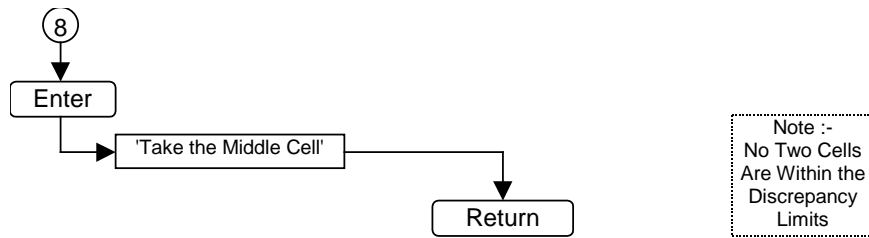

Figure 6-67. 3 Identical Cell Input Handling Flowchart (9)



**Caution** DP cell stack handling runs continuously. The S600+ immediately implements any changes you make.

**Configure the MAXIMUM number of input cells you will EVER require. This enables you to change Stack Type through a running S600+'s front panel without the risk of triggering configuration alarms because of insufficient input cells defined in the configuration file.**

## DP Cell Input Conditioning Screen

To access this screen:

1. Select **DP Cell Input Conditioning** from the hierarchy menu. The DP Cell Input Conditioning screen displays.

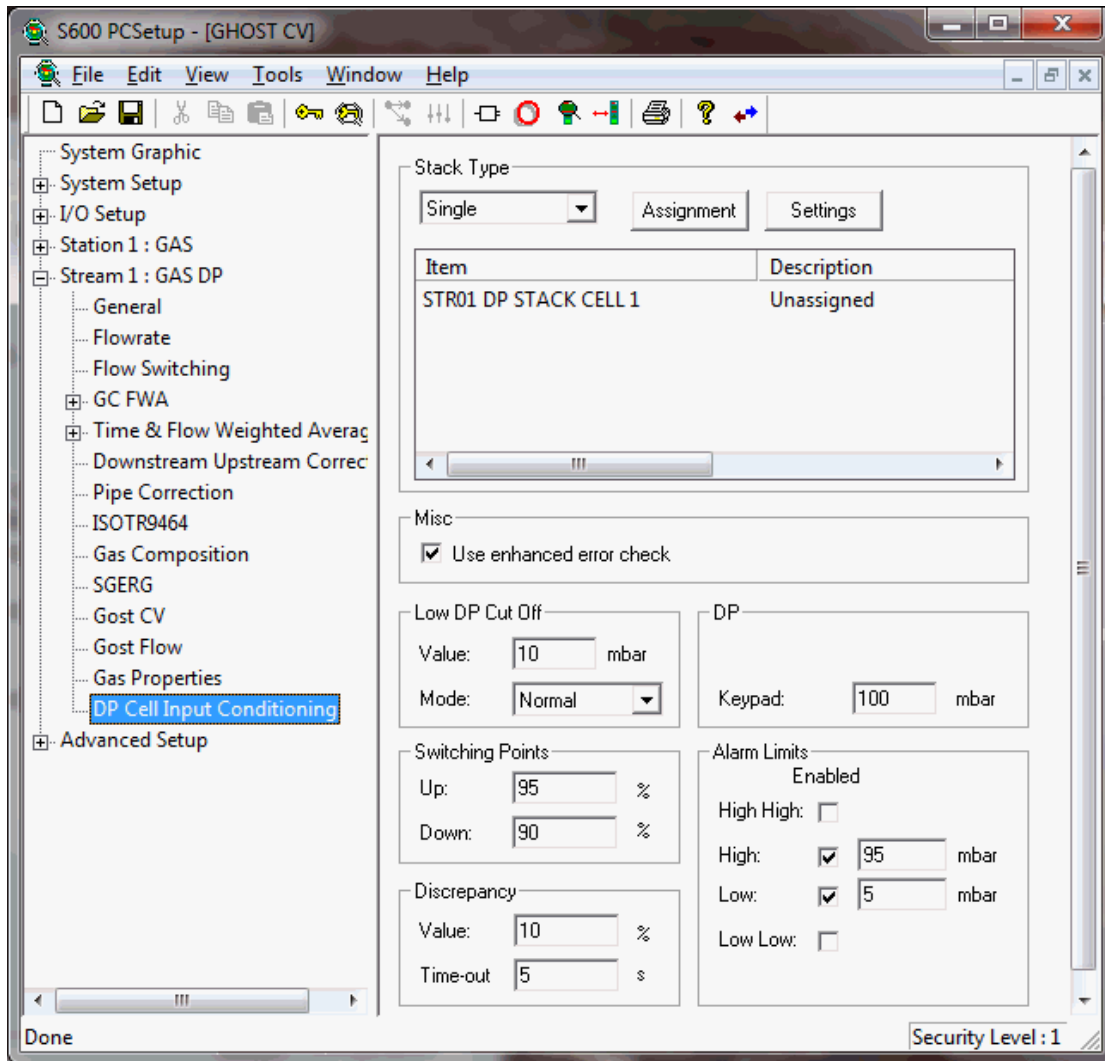

Figure 6-68. DP Cell Input Conditioning screen

2. Complete the following fields.

Field	Description
<b>Stack Type</b>	Indicates how the S600+ determines the DP value. Click ▼ to display all valid values. The default is <b>Single</b> . <b>Note:</b> Refer to <i>Cell Input Stacking</i> for a description of each stack type.
<b>ASSIGNMENT</b>	Click to display an Analog Input Assignment dialog box you use to assign AI to the selected stack type. Once you select a Stack Type, Config600 displays the associated input cell(s). If any items are unassigned, use this button to assign AI to the cell.
<b>SETTINGS</b>	Click to display an Analog Input Settings dialog box you use to edit the input assignments for the input cell with assigned AI.

Field	Description
<b>Use enhanced error check</b>	Enables enhanced error checking in the S600+. The default is checked ( <b>enabled</b> ). <b>Note:</b> If you select <b>metric</b> as your measurement units, the S600+ <b>automatically enables</b> enhanced error checking. If you select <b>Imperial</b> as your measurement units, the S600+ <b>automatically disables</b> enhanced error checking.
<b>Value</b>	Sets the value below which the S600+ does not totalise DP measurements. The default is <b>10</b> . <b>Note:</b> This value is valid only for <b>Normal</b> mode.
<b>Mode</b>	Indicates the cell input mode of operation. Click ▼ to display all valid values. <b>Normal</b> Totalisation does not occur when the measured DP is less than the value in the Value field. This is the <b>default</b> . <b>Cats</b> (Common Area Transmission System) Totalisation does not occur when the measured DP is less than the defined Low Low Alarm Limit.
<b>Up</b>	Sets the switch-up point between two input cells, expressed as a percentage of the range of the lower cell. The default is <b>95</b> . The S600+ uses this value for all cell ranges.
<b>Down</b>	Sets the switch-down point between two input cells, expressed as a percentage of the range of the lower cell. The default is <b>90</b> . The S600+ uses this value for all cell ranges.
<b>Value</b>	Sets the discrepancy allowed between the readings of two active input cells in the operating range. The value is defined as a percentage of the high scale value from the lower of the two cells. The default is <b>10</b> . <b>Note:</b> The S600+ performs this test continuously.
<b>Time-out</b>	Sets a period of time during which the S600+ ignores the discrepancy between the readings of two available transducers. The default is <b>5</b> . When the duration of the discrepancy exceeds this time limit, the S600+ raises an alarm.
<b>Startup Mode</b>	Indicates the S600+ startup mode. <b>MEASURED</b> is the <b>only</b> currently valid value.
<b>Keypad</b>	Sets a keypad value the S600+ uses as a default if it cannot select a cell (for example, all are out of range). The default is <b>100</b> .
<b>High High</b>	Enables and defines a high high alarm limit.
<b>High</b>	Enables and defines a high alarm limit.
<b>Low</b>	Enables and defines a low alarm limit.
<b>Low Low</b>	Enables and defines a low low alarm limit.

3. Click in the hierarchy menu when you finish defining settings. A confirmation dialog box displays.
4. Click **Yes** to apply your changes. The PCSetup screen displays.

## 6.5 Gas – Turbine

These stream settings are specific to gas applications. When you initially create a configuration, the calculation selections you make determine which calculation-specific screens appear in the hierarchy menu.



### Caution

**It is extremely unlikely that any one S600+ configuration would contain all the settings discussed in this section. For that reason, several sample configurations demonstrate the settings.**

### 6.5.1 AGA8 (Compressibility)

Compressibility settings define the constants and calculation limits for a range of parameters including pressure, temperature, density, and compressibility factors. This screen displays when you configure the S600+ to use the main AGA8 standard to calculate base compressibility and density, flowing compressibility and density, and standard compressibility for natural gases.

**Note:** “Standard conditions” are assumed as 14.73 psia and 60°F.

The compressibility settings also allow you to define alarms. The system activates these alarms when the calculated results are not within the specified limits.

1. Select **AGA8** from the hierarchy menu. The AGA8 screen displays.

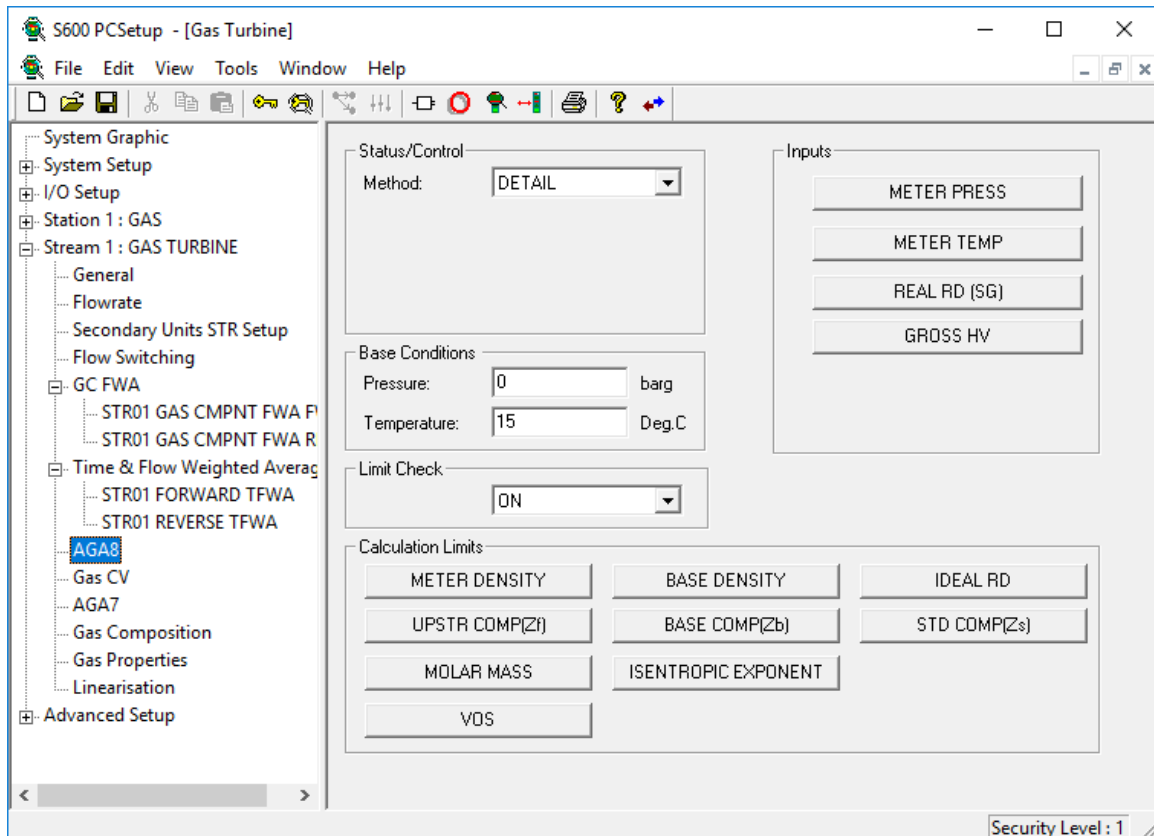

Figure 6-69. AGA8 screen

2. Complete the following fields.

<b>Field</b>	<b>Description</b>
<b>Method</b>	Indicates the compressibility calculation method. Click ▼ to display all valid values.
<b>Detail</b>	Uses 21 component values, temperature and pressure in accordance with the 1994 standard. This is the <b>default</b> .
<b>Gross1</b>	Uses SG, Heating Value, CO <sub>2</sub> , temperature and pressure in accordance with the 1991 standard. <b>Note:</b> Gross1 only supports volumetric heating value and does not support mass heating value.
<b>Gross2</b>	Uses SG, N <sub>2</sub> , CO <sub>2</sub> , temperature and pressure in accordance with the 1991 standard.
<b>VNIC</b>	Uses 20 component values, temperature and pressure in accordance with GOST 30319 1996.
<b>MGERG</b>	Uses 19 component values (As indicated in GERG Technical Monograph 2 1998) to calculate compressibility of natural gas mixtures based on a full compositional analysis.
<b>PT 1 DETAIL 2017</b>	Uses 21 component values, temperature and pressure in accordance with the 2017 standard.
<b>PT 1 GROSS1 2017</b>	Uses SG, Heating Value, CO <sub>2</sub> , temperature and pressure in accordance with the 2017 standard. <b>Note:</b> Gross1 only supports volumetric heating value and does not support mass heating value.
<b>PT 1 GROSS2 2017</b>	Uses SG, N <sub>2</sub> , CO <sub>2</sub> , temperature and pressure in accordance with the 2017 standard.
<b>PT 1 GROSS0 2017</b>	Uses 21 component values, temperature and pressure in accordance with the 2017 standard.
<b>PT 2 GERG 2008</b>	Uses 21 component values [as indicated in Table 1 AGA8 2017 Part 2 (GERG 2008)] to calculate compressibility of natural gas mixtures based on a full compositional analysis.
<b>Pressure</b>	Sets the pressure at base conditions. The default is <b>0</b> .
<b>Temperature</b>	Sets the temperature at base conditions. The default is <b>15</b> .
<b>Limit Check</b>	Click ▼ to select <b>Off</b> to disable the calculation limit checking. The default is <b>On</b> . <b>Note:</b> The compressibilities and densities will be less accurate and the calculation may fail completely when operating outside the calculation limits.
<b>METER PRESSURE</b>	Click to display a Calculation Result dialog box you use to define the mode, keypad value, and the specific alarm limits for meter pressure.

Field	Description
<b>METER TEMP</b>	Click to display a Calculation Result dialog box you use to define the mode, keypad value, and the specific alarm limits for meter temperature.
<b>REAL RD (SG)</b>	Click to display a Calculation Result dialog box you use to define the mode, keypad value, and the specific alarm limits for real relative density.
<b>GROSS HV</b>	Click to display a Calculation Result dialog box you use to define the mode, keypad value, and the specific alarm limits for gross heating value (HV).

- Click any of the following buttons to define AGA8 calculation limits.

Button	Description
<b>METER DENSITY</b>	Click to display a Calculation Result dialog box you use to define the mode, keypad value, and the specific alarm limits for meter density.
<b>UPSTR COMP(Zf)</b>	Click to display a Calculation Result dialog box you use to define the mode, keypad value, and the specific alarm limits for upstream (flowing) compressibility (Zf).
<b>MOLAR MASS</b>	Click to display a Calculation Result dialog box you use to define the mode, keypad value, and the specific alarm limits for molar mass.
<b>VOS</b>	Click to display a Calculation Result dialog box you use to define the mode, keypad value, and the specific alarm limits for the velocity of sound. <b>Note:</b> This field is visible <b>only</b> if you select either <b>PT1 DETAIL 2017</b> or <b>PT2 GERG 2008</b> in the <b>Status/Control Method</b> field.
<b>BASE DENSITY</b>	Click to display a Calculation Result dialog box you use to define the mode, keypad value, and the specific alarm limits for base density.
<b>BASE (COMP(Zb))</b>	Click to display a Calculation Result dialog box you use to define the mode, keypad value, and the specific alarm limits for base compressibility (Zb).
<b>ISENTROPIC EXPONENT</b>	Click to display a Calculation Result dialog box you use to define the mode, keypad value, and the specific alarm limits for the isentropic exponent. <b>Note:</b> This field is visible <b>only</b> if you select either <b>PT1 DETAIL 2017</b> or <b>PT2 GERG 2008</b> in the <b>Status/Control Method</b> field.
<b>IDEAL RD</b>	Click to display a Calculation Result dialog box you use to define the mode, keypad value, and the specific alarm limits for ideal relative density.
<b>STD COMP(Zs)</b>	Click to display a Calculation Result dialog box you use to define the mode, keypad value, and the specific alarm limits for standard compressibility (Zs).

- Click in the hierarchy menu when you finish defining settings. A confirmation dialog box displays.
- Click **Yes** to apply your changes. The PCSetup screen displays.

## 6.5.2 Gas CV (ISO6976 or GPA2172/ASTM D3588)

Calorific Value settings define the composition type, table to be used, and calculation limits for a range of parameters including density, relative density, and calorific value. This screen displays when you configure the S600+ to use the ISO6976 or GPA2172/ASTM D3588 standard (in step 5, Options, of the PCSetup Editor's Configuration Wizard) to calculate the calorific value (heating value) of the gas mixture.

Calorific value settings also allow you to define alarms. The system activates these alarms when the calculated results are not within the specified limits.

1. Select **Gas CV** from the hierarchy menu. The Calorific Value screen displays.

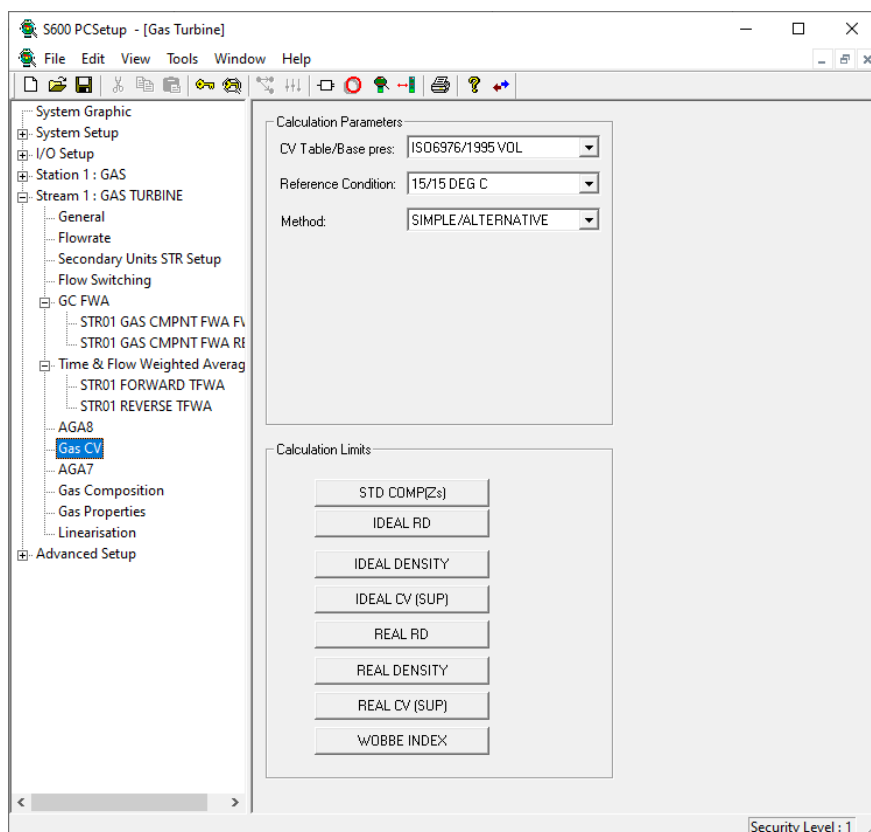

Figure 6-70. Gas CV screen

2. Complete the following fields.

Field	Description
<b>CV Table</b>	Indicates the particular compressibility value the program uses. Click ▼ to display all valid values.
<b>ISO6976/1995 Vol</b>	Calculates CV based on volume, using the 1995 table. This is the <b>default</b> if you choose CV ISO6976 as your initial stream option. <b>Note:</b> This option displays <b>only</b> if you initially configure the stream to use CV ISO6976.

Field	Description
<b>ISO6976/1995 Mass</b>	<p>Calculates CV based on mass, using the 1995 table.</p> <p><b>Note:</b> This option displays <b>only</b> if you initially configure the stream to use CV ISO6976.</p>
<b>ISO6976/1983</b>	<p>Calculates CV based on volume, using the 1983 table.</p> <p><b>Note:</b> Support for the 1983 table is limited to superior volumetric at 15/15. This option displays <b>only</b> if you initially configure the stream to use CV ISO6976.</p>
<b>ISO6976/2016 Vol</b>	<p>Calculates CV based on volume, using the 2016 table.</p> <p><b>Note:</b> This option displays <b>only</b> if you initially configure the stream to use CV ISO6976.</p>
<b>ISO6976/2016 Mass</b>	<p>Calculates CV based on mass, using the 2016 table.</p> <p><b>Note:</b> This option displays <b>only</b> if you initially configure the stream to use CV ISO6976.</p>
<b>GPA/2003 AGA (14.73)</b>	<p>Calculates CV based on a base pressure of 14.73 psia. This is the <b>default</b> if you choose CV GPA2172-ASTMD3588 as your initial stream option.</p> <p><b>Note:</b> This option displays <b>only</b> if you initially configure the stream to use CV GPA2172-ASTMD3588.</p>
<b>GPA/2003 ISO (14.696)</b>	<p>Calculates CV based on a base pressure of 14.696 psia.</p> <p><b>Note:</b> This option displays <b>only</b> if you initially configure the stream to use CV GPA2172-ASTMD3588.</p>
<b>GPA/2000 AGA (14.73)</b>	<p>Calculates CV based on a base pressure of 14.73 psia.</p> <p><b>Note:</b> This option displays <b>only</b> if you initially configure the stream to use CV GPA2172-ASTMD3588.</p>
<b>GPA/2000 ISO (14.696)</b>	<p>Calculates CV based on a base pressure of 14.696 psia.</p> <p><b>Note:</b> This option displays <b>only</b> if you initially configure the stream to use CV GPA2172-ASTMD3588.</p>
<b>GPA/1996 AGA (14.73)</b>	<p>Calculates CV based on a base pressure of 14.73 psia.</p> <p><b>Note:</b> This option displays <b>only</b> if you initially configure the stream to use CV GPA2172-ASTMD3588.</p>



Field	Description
	<p><b>GPA/1996 ISO (14.696)</b> Calculates CV based on a base pressure of 14.696 psia.</p> <p><b>Note:</b> This option displays <b>only</b> if you initially configure the stream to use CV GPA2172-ASTMD3588.</p>
	<p><b>GPA/2016 Pb (14.65)</b> Calculates CV based on a base pressure of 14.65 psia.</p> <p><b>Note:</b> This option displays <b>only</b> if you initially configure the stream to use CV GPA2172-ASTMD3588.</p>
<b>Reference Condition</b>	<p>Indicates the <math>t_1/t_2</math> value, where <math>t_1</math> is the calculation reference temperature for combustion and <math>t_2</math> is the reference condition for metering. The default is <b>15/15 DEG C</b>.</p> <p><b>Note:</b></p> <ul style="list-style-type: none"> <li>▪ For <b>ISO6976 1983 VOL</b> selection, the 60/60F and 15/15.55 Deg C selections are <b>not</b> supported.</li> <li>▪ For <b>ISO6976 1995 VOL</b> and <b>MASS</b> selections, the 60/60F selection refers to a combustion temperature (<math>t_1</math>) of 60 Deg F and a metering temperature (<math>t_2</math>) of 15 Deg C. The 15/15.55 Deg C selection is not supported.</li> </ul> <p><b>Note:</b> For Binary.app versions <b>prior to 06.30a</b>, the 60/60F selection refers to a combustion temperature (<math>t_1</math>) of 15 Deg C and a metering temperature (<math>t_2</math>) of 15 Deg C.</p> <ul style="list-style-type: none"> <li>▪ For <b>ISO6976 2016 VOL</b> and <b>MASS</b> selections, the 60/60F selection refers to a combustion temperature (<math>t_1</math>) of 60 Deg F and a metering temperature (<math>t_2</math>) of 15 Deg C. The 15/15.55 Deg C selection refers to a combustion temperature (<math>t_1</math>) of 15.55 Deg C (60 Deg F) and a metering temperature (<math>t_2</math>) of 15.55 Deg C (60 Deg F).</li> </ul> <p><b>Note:</b> For Binary.app versions <b>prior to 06.30a</b>, the 60/60F selection refers to a combustion temperature (<math>t_1</math>) of 15 Deg C and a metering temperature (<math>t_2</math>) of 15 Deg C.</p>
<b>Method</b>	<p>If you select CV ISO6976 in your initial configuration and you select the 1995 standard, you have the choice of Alternative or Definitive methods (using table 4 Mass / table 5 volume) for calculating the ideal, superior, and inferior CV values. This selection is not applicable to the 1983 or 2016 standards.</p> <p>If you select <b>CV GPA2172-ASTMD3588</b> in your initial configuration, you have the choice of the Simple (using equation 7 from the GPA2172-ASTMD3588-09 standard) or Rigorous (using equations 8 &amp; 9 from the GPA2172-ASTMD3588-09 standard) methods for calculating the standard compressibility.</p> <p><b>Note:</b> This option is valid <b>only</b> for configurations created with Config600 version 3.1 or greater.</p>

<b>Field</b>	<b>Description</b>
<b>User Temp T2</b>	Applicable to the <b>ISO6976 2016 VOL</b> and <b>ISO6976 2016 MASS</b> selections. Also applicable to <b>ISO6976 1995 VOL</b> selection when the Definitive method is selected. <b>Note:</b> It may be necessary to add this item to a display so that it can be correctly initialised.
<b>User Press P2</b>	Applicable to the <b>ISO6976 2016 VOL</b> and <b>ISO6976 1995 VOL</b> selections when the Definitive method is selected. <b>Note:</b> It may be necessary to add this item to a display so that it can be correctly initialised.
<b>Table Revision</b>	Replaces the above AGA and ISO selections in the CV Table field for GPA 2172. You can select the GPA2145 table revision from one of the following: <ul style="list-style-type: none"> <li>▪ 1996</li> <li>▪ 2000</li> <li>▪ 2003</li> <li>▪ 2009</li> </ul> <b>Note:</b> This option is valid <b>only</b> for configurations created with Config600 version 3.1 or greater.
<b>BASE COMP(Zb)</b>	Click to supply an externally calculated base compressibility from another calculation. The entered value is used in GPA2172-ASTMD3588 calculations instead of using its own internally calculated value based on the composition input.
<b>Composition Type</b>	Defines the composition input type. Valid options are: <ul style="list-style-type: none"> <li>▪ mass to energy using mole percent</li> <li>▪ mass to energy using mole fraction</li> <li>▪ volume to energy using mole percent</li> <li>▪ volume to energy using mole fraction</li> </ul> <b>Note:</b> This option is valid <b>only</b> for AGA5 configurations.

3. Click any of the following buttons to compressibility calculation limits.

<b>Button</b>	<b>Description</b>
<b>STD COMP(Zs)</b>	Click to display a Calculation Result dialog box you use to define the mode, keypad value, and the specific alarm limits for the calculated standard compressibility.
<b>IDEAL RD</b>	Click to display a Calculation Result dialog box you use to define the mode, keypad value, and the specific alarm limits for the calculated ideal relative density.
<b>IDEAL DENSITY</b>	Click to display a Calculation Result dialog box you use to define the mode, keypad value, and the specific alarm limits for the calculated ideal density.

Button	Description
<b>IDEAL CV (SUP)</b>	Click to display a Calculation Result dialog box you use to define the mode, keypad value, and the specific alarm limits for ideal calorific value. <b>Note:</b> The superior CV is output to calc field 1 of the CV object and the inferior CV is output to calc field 3. You can select either by the CV object mode from the S600+ front panel.
<b>Gross HV</b>	Click to display a Calculation Result dialog box you use to define the mode, keypad value, and the specific alarm limits for gross heating value. <b>Note:</b> This field displays <b>only</b> if you initially configure the stream to use <b>CV GPA2172-ASTMD3588</b> .
<b>REAL RD</b>	Click to display a Calculation Result dialog box you use to define the mode, keypad value, and the specific alarm limits for real relative density.
<b>REAL DENSITY</b>	Click to display a Calculation Result dialog box you use to define the mode, keypad value, and the specific alarm limits for real density.
<b>REAL CV (SUP)</b>	Click to display a Calculation Result dialog box you use to define the mode, keypad value, and the specific alarm limits for real calorific value. <b>Note:</b> The superior CV is output to calc field 1 of the CV object and the inferior CV is output to calc field 3. You can select either by the CV object mode from the S600+ front panel.
<b>WOBBE INDEX</b>	Click to display a Calculation Result dialog box you use to define the mode, keypad value, and the specific alarm limits for real calorific value. <b>Note:</b> The Wobbe Index is calculated using the Real Superior CV.
<b>REAL VOL IDEAL HV</b>	Click to display a Calculation Result dialog box you use to define the mode, keypad value, and the specific alarm limits for the real volume ideal heating value. <b>Note:</b> This field displays only if you initially configure the stream to use <b>CV GPA2172-ASTMD3588</b> .

- Click in the hierarchy menu when you finish defining settings. A confirmation dialog box displays.
- Click **Yes** to apply your changes. The PCSetup screen displays.

### 6.5.3 AGA7 (Gross Volume Flowrate)

The AGA7 settings define the constants and calculation limits for a range of parameters including meter pressure, temperature, and compressibility. This screen displays when you configure the S600+ to use the AGA7 standards to calculate the gross volume flowrate from a gas turbine.

The AGA7 settings also allow you to define alarms. The system activates these alarms when the calculated results are not within specified limits.

- Select **AGA7** from the hierarchy menu. The AGA7 screen displays.

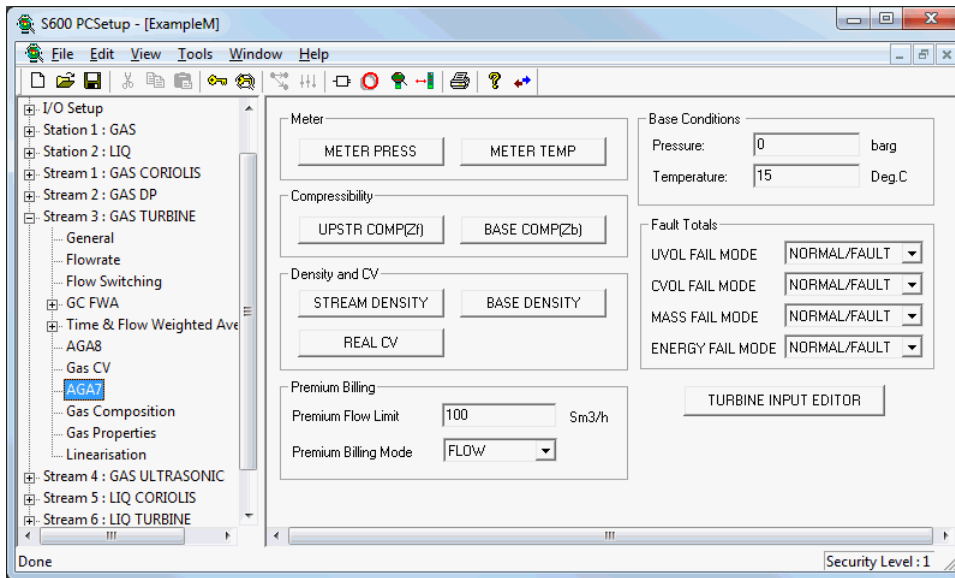

Figure 6-71. AGA7 screen

2. Complete the following fields.

Field	Description
<b>METER PRESS</b>	Click to display an Analog Inputs dialog box you use to define the analog input values associated with this stream, I/O module, and channel, as well as conversion factors and alarm limits.
<b>METER TEMP</b>	Click to display an Analog Inputs dialog box you use to define the analog input values associated with this stream, I/O module, and channel, as well as conversion factors and alarm limits.
<b>UPSTR COMP(Zf)</b>	Click to display a Calculation Result dialog box you use to define the mode, keypad value, and the specific alarm limits for the upstream compressibility (Zf).
<b>BASE COMP(Zb)</b>	Click to display a Calculation Result dialog box you use to define the mode, keypad value, and the specific alarm limits for the base compressibility (Zb).
<b>STREAM DENSITY</b>	Click to display a Calculation Result dialog box you use to define the mode, keypad value, and the specific alarm limits for the stream density.
<b>BASE DENSITY</b>	Click to display a Calculation Result dialog box you use to define the mode, keypad value, and the specific alarm limits for the base density.
<b>REAL CV</b>	Click to display a Calculation Result dialog box you use to define the mode, keypad value, and the specific alarm limits for the real calorific value.
<b>Premium Flow Limit</b>	In Premium Billing FLOW mode. sets a flowrate limit above which the system increments forward premium totals whenever the flowrate exceeds the keypad limit. In Premium Billing TOTAL mode, sets a total limit above which the system increments forward premium totals whenever the period total exceeds the keypad limit. The default is <b>100</b> .
<b>Premium Billing Mode</b>	Indicates the premium total mode, in which the system increments premium totals at the end of a period only if the period total exceeds the keypad limit. Click ▼ to display all valid values. The default is <b>FLOW</b> .
<b>Pressure</b>	Sets pressure at base conditions. The default is <b>0</b> .

Field	Description
<b>Temperature</b>	Sets temperature at base conditions. The default is <b>15</b> .
<b>UVOL Fail Mode</b>	<p>Indicates the fault total option for the uncorrected volume. Click ▼ to display all valid values.</p> <p><b>Note:</b> If you define fault totals but do not use them, the S600+ does not include them in reports and displays at run time.</p> <hr/> <p><b>FAULT ONLY</b> When fault condition is active, only increment fault totals.</p> <hr/> <p><b>NORMAL ONLY</b> When fault condition is active, only increment normal totals.</p> <hr/> <p><b>NORMAL/FAULT</b> When fault condition is active, increment both normal and fault totals. This is the <b>default</b>.</p>
<b>CVOL Fail Mode</b>	<p>Indicates the fault total option mode for the corrected volume. Click ▼ to display all valid values.</p> <p><b>Note:</b> If you define fault totals but do not use them, the S600+ does not include them in reports and displays at run time.</p> <hr/> <p><b>FAULT ONLY</b> When fault condition is active, only increment fault totals.</p> <hr/> <p><b>NORMAL ONLY</b> When fault condition is active, only increment normal totals.</p> <hr/> <p><b>NORMAL/FAULT</b> When fault condition is active, increment both normal and fault totals. This is the <b>default</b>.</p>
<b>Mass Fail Mode</b>	<p>Indicates the fault total option for the mass fail mode. Click ▼ to display all valid values.</p> <p><b>Note:</b> If you define fault totals but do not use them, the S600+ does not include them in reports and displays at run time.</p> <hr/> <p><b>FAULT ONLY</b> When fault condition is active, only increment fault totals.</p> <hr/> <p><b>NORMAL ONLY</b> When fault condition is active, only increment normal totals.</p> <hr/> <p><b>NORMAL/FAULT</b> When fault condition is active, increment both normal and fault totals. This is the <b>default</b>.</p>
<b>Energy Fail Mode</b>	<p>Indicates the fault total option for the energy fail mode. Click ▼ to display all valid values.</p> <p><b>Note:</b> If you define fault totals but do not use them, the S600+ does not include them in reports and displays at run time.</p> <hr/> <p><b>FAULT ONLY</b> When fault condition is active, only increment fault totals.</p> <hr/> <p><b>NORMAL ONLY</b> When fault condition is active, only increment normal totals.</p> <hr/> <p><b>NORMAL/FAULT</b> When fault condition is active, increment both normal and fault totals. This is the <b>default</b>.</p>
<b>TURBINE INPUT EDITOR</b>	Click to display the Turbine Inputs screen on the I/O Setup option.

3. Click in the hierarchy menu when you finish defining settings. A confirmation dialog box displays.
4. Click **Yes** to apply your changes. The PCSetup screen displays.

## 6.5.4 Stream Gas Composition

Stream Gas Composition settings define the processing and port telemetry parameters for streams receiving data from the gas chromatograph controller. The chromatograph controller measures the individual component concentrations found in the line gas. The chromatograph controller settings also allow you to define alarms. The system activates these alarms when the calculated results for the chromatograph data are not within specified limits.

1. Select **Gas Composition** from the hierarchy menu. The Gas Composition screen displays.

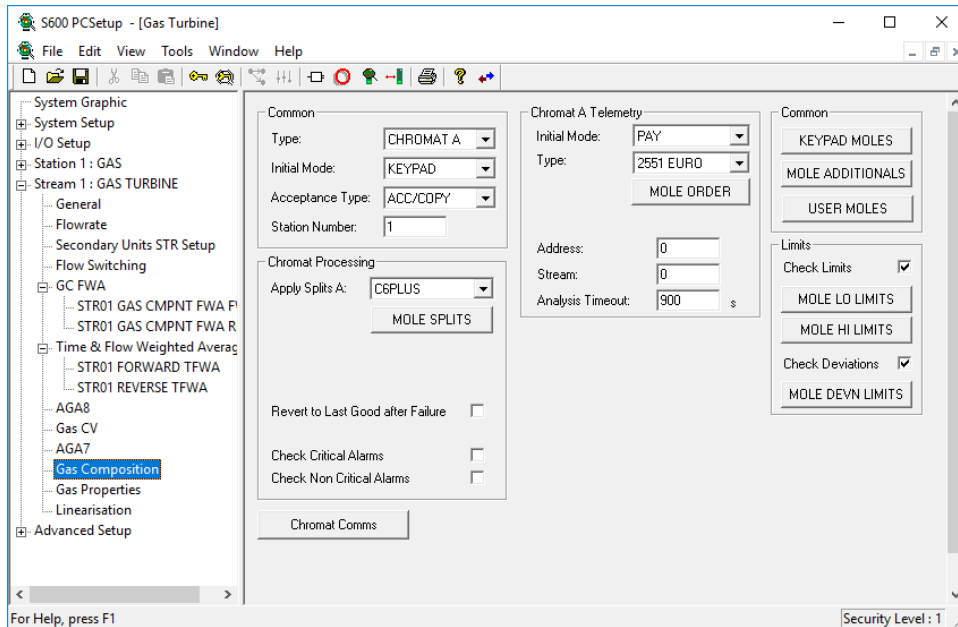

Figure 6-72. Gas Composition screen

2. Complete the following fields.

Field Type	Description
<b>CHROMAT A</b>	Indicates the chromatograph configuration. Click ▼ to display all valid values. Controller-connected; uses keypad data as fallback information.
<b>KP ONLY</b>	Not controller-connected; uses information entered via keypad. This is the <b>default</b> .
<b>Note:</b>	If you select <b>KP ONLY</b> , the system hides a number of fields on this screen.

Field	Description
<b>Initial Mode</b>	Indicates the operational mode for the in-use composition data. Click ▼ to display all valid values.
	<b>KEYPAD</b> Use data entered via keypad. This is the <b>default</b> .
	<b>CHROMAT</b> Use live data from the chromatograph controller.
	<b>DOWNLOAD</b> Download gas composition data directly to each stream. Used only if connected to a remote supervisory computer.
	<b>USER</b> Use customised program for gas composition in S600+.
	<b>KEYPAD_F</b> Start by using keypad-entered data then switch to chromatograph data when a good analysis is received.
<b>Acceptance Type</b>	Indicates how the S600+ manages in-use data. Click ▼ to display all valid values.
	<b>ACC/COPY</b> Copy and normalise keypad data to in-use data only after it is accepted. This is the <b>default</b> .
	<b>ACC/NORM</b> Copy normalised keypad data to in-use data after it is accepted.
	<b>AUTO/NORM</b> Automatically copy normalised keypad data to in-use data.
<b>Station Number</b>	Sets the station associated with this stream. The default is 1.
<b>Apply Splits</b>	Indicates the type of analyser connected to the S600+. For a C6+ analyser, use the C6Plus option. Click ▼ to display all valid values. The default is <b>NO SPLITS</b> . If you select any value other than <b>NO SPLITS</b> , the system displays the <b>MOLE SPLITS</b> button. Use this button to define the specific percentage splits for the gases. <b>Note:</b> This field displays <b>only</b> if you select <b>CHROMAT A</b> as the chromatograph configuration type.
<b>Revert to Last Good after Failure</b>	Continues using the last good composition in the event of failure. Otherwise the system reverts to keypad data. <b>Note:</b> This field displays <b>only</b> if you select <b>CHROMAT A</b> as the chromatograph configuration type.
<b>Check Critical Alarms</b>	Marks the received composition as failed if any critical alarm is set (such as the pre-amp fail on the Danalyzer for a Daniel 2551 Controller). <b>Note:</b> This field displays <b>only</b> if you select <b>CHROMAT A</b> as the chromatograph configuration type.
<b>Check Non Critical Alarms</b>	Marks the received composition as failed if any non-critical alarm is set (such as the pre-amp fail on the Danalyzer for a Daniel 2551 Controller). <b>Note:</b> This field displays <b>only</b> if you select <b>CHROMAT A</b> as the chromatograph configuration type.
<b>CHROMAT COMMS</b>	Click to display the Comm screen in I/O Setup (see <i>Chapter 4, Section 4.10</i> ).

Field	Description												
<b>Initial Mode</b>	<p>Identifies the chromatograph and any fallback controllers. Currently, the only valid value is <b>PAY</b>, which indicates one chromatograph and no fallback controller.</p> <p><b>Note:</b> This field displays <b>only</b> if you select <b>CHROMAT A</b> as the chromatograph configuration type.</p>												
<b>Type</b>	<p>Indicates the type of chromatograph controller connected to the S600+. Click ▼ to display all valid values.</p> <p><b>Note:</b> This field displays <b>only</b> if you select <b>CHROMAT A</b> as the chromatograph configuration type.</p> <table border="1" style="width: 100%; border-collapse: collapse;"> <tr> <td style="padding: 2px;"><b>2551 EURO</b></td> <td style="padding: 2px;">S600+ is connected to a Daniel 2551 (European) controller. This is the <b>default</b>.</td> </tr> <tr> <td style="padding: 2px;"><b>2350 EURO</b></td> <td style="padding: 2px;">S600+ is connected to a Daniel 2350 (European) controller set in SIM_2251 mode.</td> </tr> <tr> <td style="padding: 2px;"><b>2350 USA</b></td> <td style="padding: 2px;">S600+ is connected to a Daniel 2350 (USA) controller set in SIM_2251 mode.</td> </tr> <tr> <td style="padding: 2px;"><b>2251 USA</b></td> <td style="padding: 2px;">S600+ is connected to a Daniel 2251 controller.</td> </tr> <tr> <td style="padding: 2px;"><b>Generic</b></td> <td style="padding: 2px;">S600+ is connected to another type of controller.</td> </tr> <tr> <td style="padding: 2px;"><b>Siemens</b></td> <td style="padding: 2px;">S600+ is connected to a Siemens Advance Maxum via a Siemens Network Access Unit (NAU).</td> </tr> </table>	<b>2551 EURO</b>	S600+ is connected to a Daniel 2551 (European) controller. This is the <b>default</b> .	<b>2350 EURO</b>	S600+ is connected to a Daniel 2350 (European) controller set in SIM_2251 mode.	<b>2350 USA</b>	S600+ is connected to a Daniel 2350 (USA) controller set in SIM_2251 mode.	<b>2251 USA</b>	S600+ is connected to a Daniel 2251 controller.	<b>Generic</b>	S600+ is connected to another type of controller.	<b>Siemens</b>	S600+ is connected to a Siemens Advance Maxum via a Siemens Network Access Unit (NAU).
<b>2551 EURO</b>	S600+ is connected to a Daniel 2551 (European) controller. This is the <b>default</b> .												
<b>2350 EURO</b>	S600+ is connected to a Daniel 2350 (European) controller set in SIM_2251 mode.												
<b>2350 USA</b>	S600+ is connected to a Daniel 2350 (USA) controller set in SIM_2251 mode.												
<b>2251 USA</b>	S600+ is connected to a Daniel 2251 controller.												
<b>Generic</b>	S600+ is connected to another type of controller.												
<b>Siemens</b>	S600+ is connected to a Siemens Advance Maxum via a Siemens Network Access Unit (NAU).												
<b>MOLE ORDER</b>	<p>Click this button to display a Gas Composition dialog box on which you use to indicate the order in which the gas composition information comes into the S600+ via telemetry. <b>0</b> indicates any component which is <b>not</b> included in the Modbus map.</p> <p><b>Note:</b></p> <ul style="list-style-type: none"> <li>▪ The Modbus map you create must be compatible with the controller to which the S600+ is connected. Refer to <i>Chapter 14, Modbus Editor</i>, for further information.</li> <li>▪ This field displays <b>only</b> if you select <b>CHROMAT A</b> as the chromatograph configuration type.</li> <li>▪ This field is applicable <b>only</b> if you select <b>Siemens</b> or <b>Generic</b> in the Type field.</li> </ul>												
<b>Address</b>	<p>Configures multi-drop chromatograph support. <b>Do not change unless advised to do so.</b></p> <p><b>Note:</b> This field displays <b>only</b> if you select <b>CHROMAT A</b> as the chromatograph configuration type.</p>												
<b>Stream</b>	<p>Sets the chromat analysis stream assigned to this metering stream. The default is <b>0</b>.</p> <p><b>Note:</b> This field displays <b>only</b> if you select <b>CHROMAT A</b> as the chromatograph configuration type. If you need to support more than one stream, contact Technical Support.</p>												



<b>Field</b>	<b>Description</b>
<b>Analysis Timeout</b>	<p>Sets the maximum number of seconds the S600+ waits to receive a new composition from the chromatograph controller before raising an alarm. The default is <b>900</b>.</p> <p><b>Note:</b> This field displays <b>only</b> if you select <b>CHROMAT A</b> as the chromatograph configuration type.</p>
<b>Download Timeout</b>	<p>Sets the maximum number of minutes the S600+ waits to receive a new composition from the supervisory computer before raising a <b>DL Timeout Alarm</b>. The default is <b>15</b>.</p> <p><b>Note:</b></p> <ul style="list-style-type: none"> <li>▪ A value of <b>0</b> disables the timeout.</li> <li>▪ This field displays <b>only</b> if you select <b>KP ONLY</b> in the Common Type field.</li> </ul>
<b>KEYPAD MOLES</b>	<p>Click to display a dialog box you use to define mole percentage values for each gas component.</p> <p><b>Note:</b> The system assumes the keypad composition adds to 100% (normalised) when the Acceptance Type is ACC/COPY. If you select ACC/NORM or AUTO/NORM, the system automatically normalises the keypad composition.</p>
<b>MOLE ADDITIONAL</b>	<p>Click to display a dialog box you use to define mole percentage values for gas components not analysed by the Danalyzer. The system assumes any additional components to be normalised values, and the analyser components are re-normalised (100 – sum of additional components).</p> <p><b>Note:</b> This field displays <b>only</b> if you select <b>CHROMAT A</b> as the chromatograph configuration type.</p>
<b>USER MOLES</b>	<p>Click to display a dialog box you use to define mole percentage values for each gas component. The system assumes user moles to be normalised.</p> <p><b>Note:</b> The S600+ uses these values <b>only</b> if you set the Initial Mode to <b>USER</b>. A Modbus download from another computer may overwrite these values on a running configuration.</p>
<b>Check Limits</b>	<p>Enables limit checking on each gas component. When you select this check box, the <b>MOLE LO LIMITS</b> and <b>MOLE HI LIMITS</b> buttons display.</p>

Field	Description
<b>MOLE LO LIMITS</b>	<p>Click to display a dialog box you use to define low mole percentage limit values for each gas component. Enter <b>0</b> in any field to prevent the test for the selected component.</p> <p><b>Note:</b></p> <ul style="list-style-type: none"> <li>▪ The system uses the values you enter through these buttons <b>only</b> if you select the Check Limits check box. The system applies this test to the keypad, downloaded, user, additional, and new analysis components. When enabled, the system applies the limit check against the high and low limits. Limits are considered valid if the limit is greater than zero (0). The system also applies the check to the Total field. If you <b>disable</b> the limit check, the keypad, downloaded and user Total field must lie within 0.1% and 150%. A sum of the new analysis must be within 99.5% and 100.5%.</li> <li>▪ This field displays <b>only</b> if you place a check mark in the Check Limits field.</li> </ul>
<b>MOLE HI LIMITS</b>	<p>Click to display a dialog box you use to define high mole percentage limit values for each gas component. Enter <b>0</b> in any field to prevent the test for the selected component.</p> <p><b>Note:</b> See note in description of Mole Lo Limits field.</p>
<b>Check Deviations</b>	<p>Enables checking on the deviation from the last good analysis for each component. When you select this check box, the <b>MOLE DEVN LIMITS</b> button displays.</p> <p><b>Note:</b> This field displays <b>only</b> if you select <b>CHROMAT A</b> as the chromatograph configuration type.</p>
<b>MOLE DEVN LIMITS</b>	<p>Click to display a dialog box you use to define the maximum deviation allowed for each gas component. Enter <b>0</b> in any field to prevent the test for the selected component.</p> <p><b>Note:</b> This field displays <b>only</b> if you place a check mark in the Check Deviations field.</p>

3. Click in the hierarchy menu when you finish defining settings. A confirmation dialog box displays.
4. Click **Yes** to apply your changes. The PCSetup screen displays.

### 6.5.5 Gas Properties

Gas Properties settings define methods the system uses to calculate viscosity, isentropic exponent (also known as “specific heat ratio” or “adiabatic exponent), and the velocity of sound. ”)

These settings also allow you to define alarms. The system activates these alarms when the calculated results are not within the specified limits.

1. Select **Gas Properties** from the hierarchy menu. The Gas Properties screen displays.

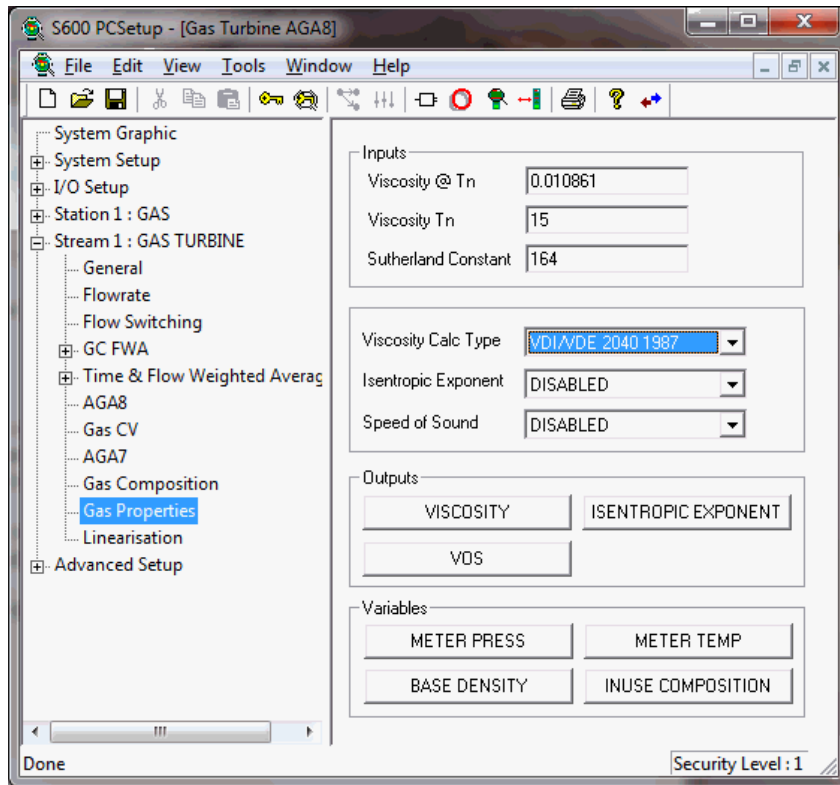

Figure 6-73. Gas Properties screen

2. Complete the following fields.

Field	Description
<b>Viscosity @ Tn</b>	Sets the reference viscosity for the gas. The default is <b>0.010861</b> . <b>Note:</b> Used <b>only</b> by VDI/VDE.
<b>Viscosity Tn</b>	Sets the reference viscosity temperature for the gas. The default is <b>15</b> . <b>Note:</b> Used <b>only</b> by VDI/VDE.
<b>Sutherland Constant</b>	Sets the Sutherland constant for the gas. The default is <b>164</b> . <b>Note:</b> Used <b>only</b> by VDI/VDE.
<b>Viscosity Calc Type</b>	Indicates the method for calculating the viscosity of the gas. Click ▼ to display all valid values. <b>Disabled</b> Value not calculated; defaults to keypad-entered value. This is the <b>default</b> . <b>SGERG GOST 30139-2015</b> Uses calculations from GOST 30139-2015. Requires base density, N <sub>2</sub> , and CO <sub>2</sub> inputs. <b>VDI/VDE 2040 1987</b> Uses calculations from VDI/VDE 2040 Part 2 1987. Requires viscosity @T <sub>n</sub> , viscosity T <sub>n</sub> , and Sutherland Constant inputs. <b>VNIC GOST 30319-2015</b> Uses calculations from GOST 30319-2015. Requires full gas composition input.
<b>Isentropic Exponent</b>	Indicates the method for calculating the isentropic exponent of the gas. Click ▼ to display all valid values. <b>AGA10 2003</b> Uses calculations from AGA10 2003. Requires full gas composition input.

Field	Description
<b>Disabled</b>	Value not calculated; defaults to keypad-entered value. This is the <b>default</b> .
<b>GRI 1991</b>	Uses calculations from GRI 1991. Requires full gas composition input.
<b>SGERG GOST 30139-2015</b>	Uses calculations from GOST 30139-2015. Requires Base Density, N <sub>2</sub> and CO <sub>2</sub> inputs.
<b>VNIC GOST 30319-2015</b>	Uses calculations from GOST 30319-2015. Requires full gas composition input.
<b>Speed of Sound</b>	Indicates the method for calculating the speed of sound. Click ▼ to display all valid values.
<b>AGA10 2003</b>	Uses calculations from AGA10 2003. Requires full gas composition input.
<b>Disabled</b>	Value not calculated; defaults to keypad-entered value. This is the <b>default</b> .
<b>GRI 1991</b>	Uses calculations from GRI 1991. Requires full gas composition input.
<b>SGERG GOST 30139-2015</b>	Uses calculations from GOST 30139-2015. Requires Base Density, N <sub>2</sub> and CO <sub>2</sub> inputs.
<b>VNIC GOST 30319-2015</b>	Uses calculations from GOST 30319-2015. Requires full gas composition input.

- Click any of the following buttons to set gas property outputs or variables.

Button	Description
<b>VISCOSITY</b>	Click to display a Calculation Result dialog box you use to define the mode, keypad value, and the specific alarm limits for viscosity.
<b>ISENTROPIC EXPONENT</b>	Click to display a Calculation Result dialog box you use to define the mode, keypad value, and the specific alarm limits for the isentropic exponent.
<b>VOS</b>	Click to display a Calculation Result dialog box you use to define the mode, keypad value, and the specific alarm limits for the velocity of sound. <b>Note:</b> AGA10 refers to VOS as “speed of sound.”
<b>UPSTREAM PRESS</b>	Click to display a Calculation Result dialog box you use to define the mode, keypad value, and the specific alarm limits for upstream pressure.
<b>UPSTREAM TEMP</b>	Click to display a Calculation Result dialog box you use to define the mode, keypad value, and the specific alarm limits for upstream temperature.
<b>BASE DENSITY</b>	Click to display a Calculation Result dialog box you use to define the mode, keypad value, and the specific alarm limits for base density.
<b>INUSE COMPOSITION</b>	Click to display a <b>read-only</b> table of gas compositions. This corresponds to the table defined using the Gas Composition screen’s <b>KEYPAD MOLES</b> button.

- Click in the hierarchy menu when you finish defining settings. A confirmation dialog box displays.

- Click **Yes** to apply your changes. The PCSetup screen displays.

### 6.5.6 Local Units

This option allows you to override the global K-factor unit, since a gas application may have more than one type of meter, each using different K-factor units.

- Select **Local Units** from the hierarchy menu. The Local Units screen displays.

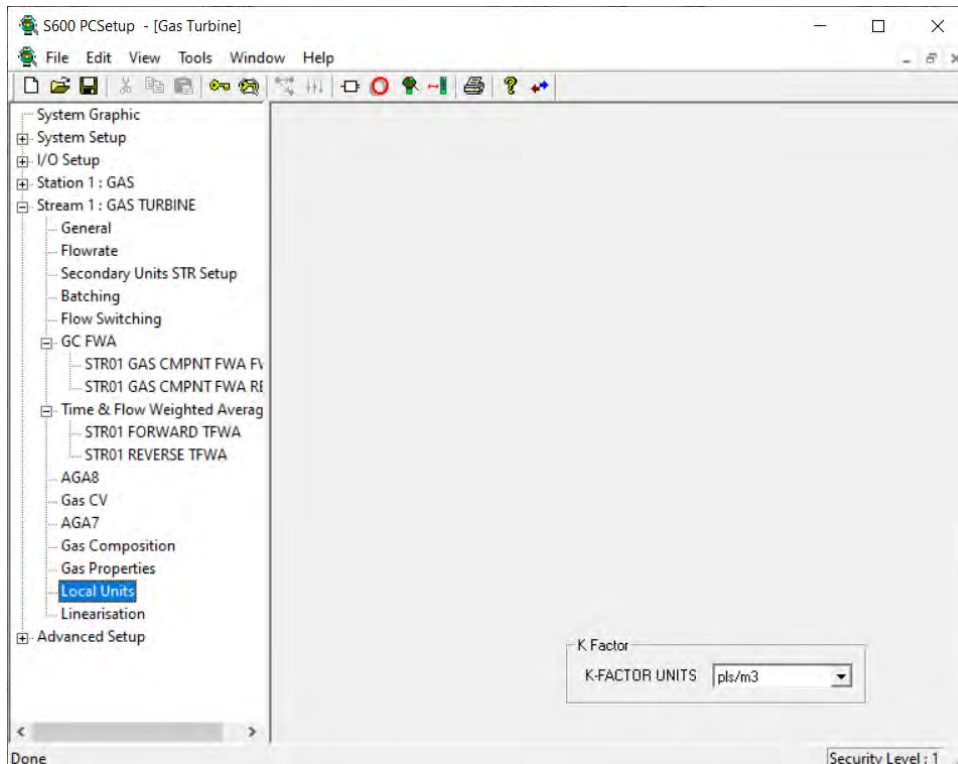

Figure 6-74. Local Units screen

- Complete the following field.

Field	Description
<b>K-Factor Units</b>	Indicates the type of units to use and override the system K-factor units of measurement. Click ▼ to display all valid values. The default is <b>SYSTEM UNITS</b> . <b>Note:</b> If you select <b>System Units</b> , the stream uses the global default value.

- Click in the hierarchy menu when you finish defining settings. A confirmation dialog box displays.
- Click **Yes** to apply your changes. The PCSetup screen displays.

### 6.5.7 Linearisation

Linearisation settings define the constants and calculation limits for the meter factor and K-factor. The S600+ calculates a meter factor and K-factor corresponding to the turbine frequency by interpolating the frequency between fixed points and then cross-referencing the result against a lookup table.

Linearisation settings also allow you to define alarms. The system activates these alarms when the calculated results for the meter factor and K factor are not within specified limits.

Flow meters produce pulses proportional to the total flow through the meter, and the K-factor represents the number of pulses produced per unit volume.

---

**Notes:**

- The linearisation curve for Gas Turbine configurations uses frequency as the default input for both K-factor and Meter Factor calculations. The ability to change the defaults is available **only** with Config600 Pro software.
- Batching systems that employ meter factor or K-factor linearisation with retrospective meter factor/K-factor adjustments assume that the adjusted value has a “keypad” mode.
- To prevent the live metering system from applying a double correction, use **either** a calculated meter factor **or** a calculated K-factor linearisation (that is, only one factor should have a calculated mode).

- 
1. Select **Linearisation** from the hierarchy menu. The Linearisation screen displays.

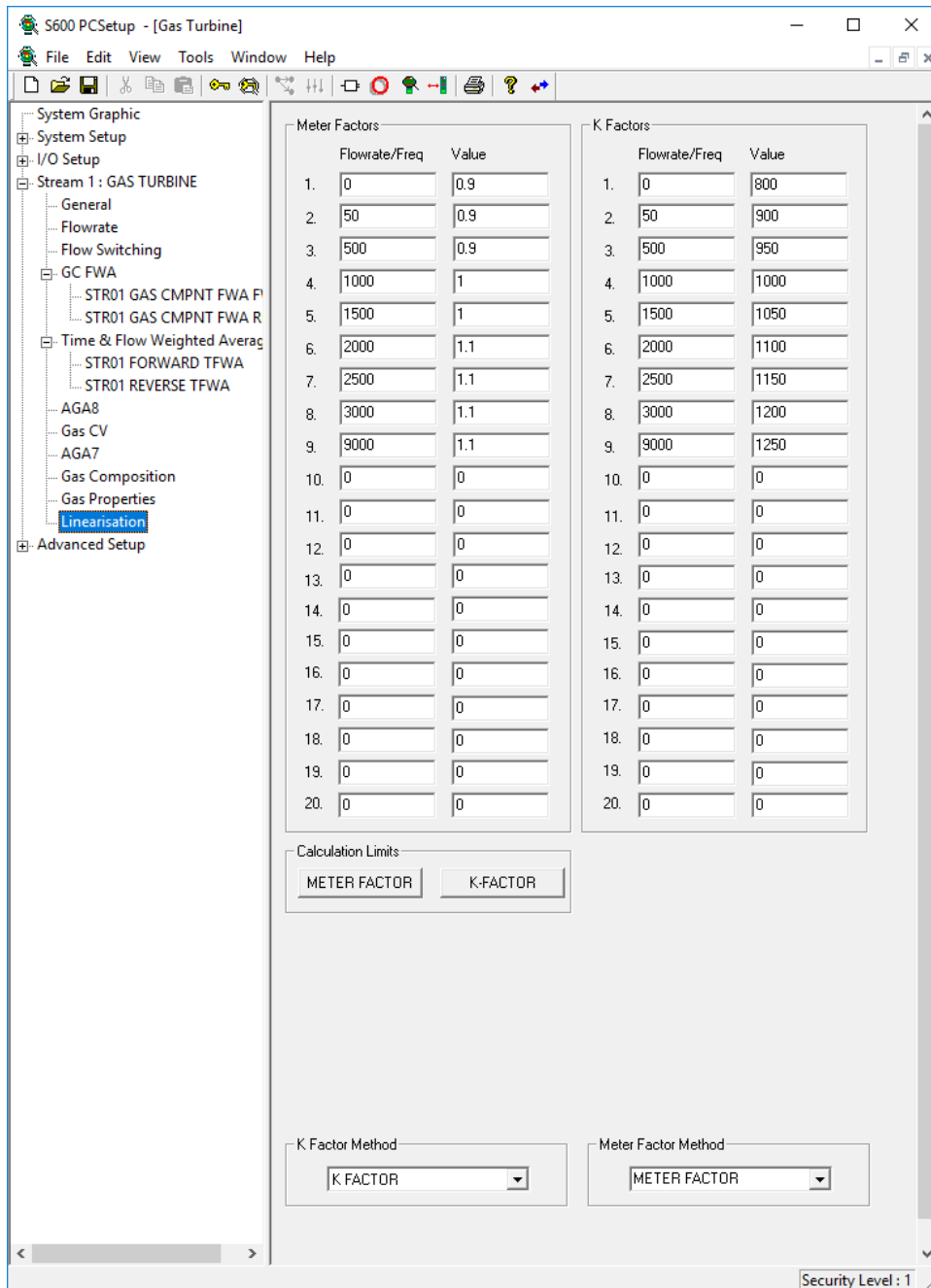

Figure 6-75. Linearisation screen

2. Complete the following field.

Field	Description
<b>Meter Factors</b>	Sets up to 20 flow rate and values for the meter corrector factors.
<b>Flowrate/Freq</b>	Sets the flowrate and frequency for each of the meter correction factors.
<b>Value</b>	Sets the corresponding values for each of the meter correction factors.
<b>K-Factors</b>	Sets up to 20 flow rate and values for the K-factors.
<b>Flowrate/Freq</b>	Sets the flowrate and frequency for each of the K-factors.
<b>Value</b>	Sets the corresponding values for each of the K-factors.

Field	Description
<b>METER FACTOR</b>	Click to display a Calculation Result dialog box you use to define the mode, keypad value, and the specific alarm limits for the respective factor.
<b>K-FACTOR</b>	Click to display a Calculation Result dialog box you use to define the mode, keypad value, and the specific alarm limits for the respective factor.
<b>K Factor Method</b>	Selectable between K FACTOR (values entered as normal) and ERROR PERCENT (K Factor entered as a percentage).
<b>Meter Factor Method</b>	Selectable between METER FACTOR (values entered as normal) and ERROR PERCENT (Meter Factor entered as a percentage).

3. Click in the hierarchy menu when you finish defining settings. A confirmation dialog box displays.
4. Click **Yes** to apply your changes. The PCSetup screen displays.

### 6.5.8 Sampling

Sampling defines the method and interval period for sampling product from a flowing pipeline. By default, Config600 supports one sampler per stream. Config600 uses the following stages during the sampling process:

Stage	Description
<b>0</b>	Idle
<b>1</b>	Monitor
<b>2</b>	Digout n
<b>3</b>	Min Intvl
<b>4</b>	Post Pulse
<b>5</b>	Stopped Manually
<b>6</b>	Stopped Can Full
<b>7</b>	Stopped Low Flow
<b>8</b>	Initial Time
<b>9</b>	Check Flow Switch
<b>10</b>	Stopped Flow Switch
<b>11</b>	Stopped Press Switch
<b>12</b>	Stopped initialise
<b>13</b>	Can Switch Over

---

**Note:** Batch auto-resets the sampler at the start of the batch.

---

1. Select **Sampling** from the hierarchy menu. The Sampling screen displays.



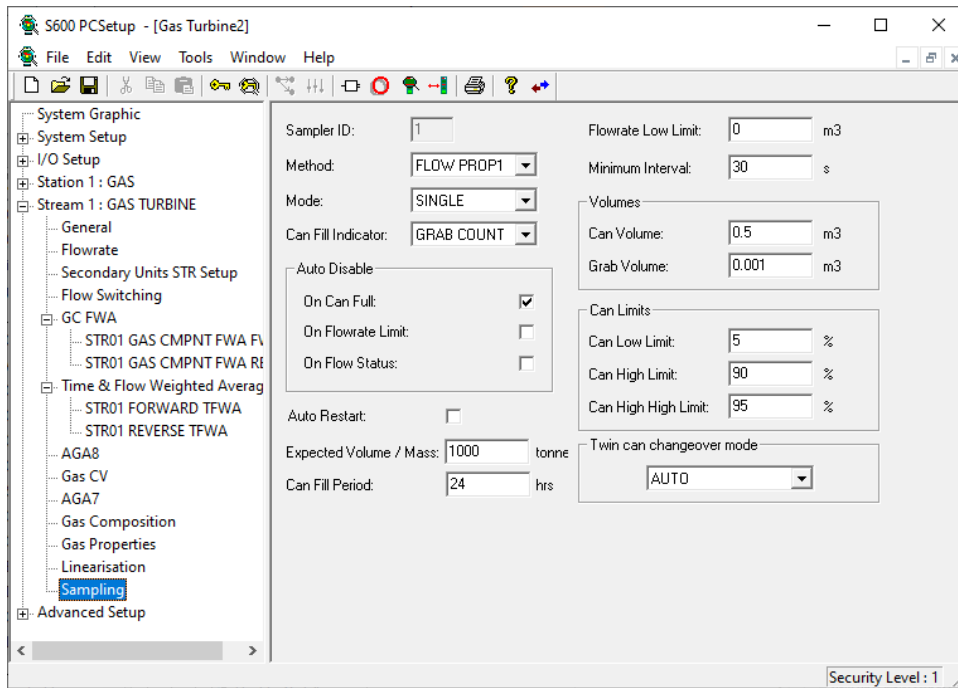

Figure 6-76. Stream Sampling screen

2. Complete the following fields.

Field	Description
<b>Sampler ID</b>	Provides an identifying label for the sampler. Each stream or station must have a unique sampler ID and must be greater than zero.
<b>Method</b>	Indicates the sampling method. Click ▼ to display all valid values.
<b>TIME PROP</b>	Divides the value in the Can Fill Period field by the number of grabs needed to fill the can (derived from the Can Volume and Fill Volume values) to determine a time interval per pulse. This is the <b>default</b> .
<b>FLOW PROP1</b>	Divides the value in the Volume field by the number of grabs needed to fill the can (derived from the Can Volume and Fill Volume values) to determine a volume throughput per pulse.
<b>FLOW PROP2</b>	Uses the value in the Volume field as the volume throughput per pulse.
<b>FLOW PROP3</b>	Uses the value in the Volume field as the volume throughput per pulse, but supports low pressure digital input and pump prime output.

Field	Description
<b>Mode</b>	Indicates the sampling mode. Click ▼ to display all valid values. The S600+ uses Can 1 or Can 2.
	<b>SINGLE</b> Acquire sample in one trial. This is the <b>default</b> .
	<b>DUAL</b> Acquire samples in two trials. <b>Note:</b> If you select <b>Dual</b> , the sampler switches to a second can when the current can is full (according to the two can switchover mode).
<b>Can Fill Indicator</b>	Indicates when the sampling can is full. Click ▼ to display all valid values.
	<b>GRAB COUNT</b> Uses the number of pulses output to the sampler to determine when the sample is full. This is the <b>default</b> .
	<b>DIG I/P</b> Uses a digital input to determine when the sampler is full.
	<b>ANALOG I/P</b> Uses an analog input to determine when the sampler is full.
<b>Auto Disable</b>	Indicates the event at which the system automatically disables the sampling process. Select the appropriate check box to identify the specific event.
	<b>On Can Full</b> Disables the sampling process when the can is full. This is the <b>default</b> .
	<b>On Flowrate Limit</b> Disables the sampling process when the flowrate is less than the value of the Flowrate Low Limit.
	<b>On Flow Status</b> Disables the sampling process when the flow status value is not on-line.
<b>Auto Restart</b>	Automatically restarts (if selected) sampling following an automatic disabling.
<b>Expected Volume/Mass</b>	Indicates, in cubic meters, the expected flow volume or mass of the sampling can. This is the value the Flow Prop1 and Flow Prop2 sampling methods use for calculations. The default is <b>1000</b> .
<b>Can Fill Period</b>	Sets, in hours, the time required to fill the sampling can. The default is <b>24</b> . <b>Note:</b> The Time Prop sampling method uses this value for its calculations.
<b>Flowrate Low Limit</b>	Indicates flowrate low limit used by the Auto Disable on Flowrate Limit option. The default is <b>0</b> . <b>Note:</b> This field is required if you select the On Flowrate Limit check box for Auto Disable.
<b>Minimum Interval</b>	Indicates, in seconds, the minimum amount of time between grabs. This is the value the Time Prop sampling method uses for its calculations. The default is <b>30</b> . <b>Note:</b> If the sample exceeds this limit, the system sets the overspeed alarm and increments the overspeed counter.

Field	Description
<b>Volumes</b>	<b>Can Volume</b> Indicates, in cubic meters, the volume of the sampling can. The default is <b>0.5</b> .
	<b>Grab Volume</b> Indicates, in cubic meters, the volume of the sampling grab. The default is <b>0.001</b> .
<b>Can Limits</b>	<b>Can Low Limit</b> Indicates the low alarm value as a percentage of the can volume. The default is <b>5</b> .
	<b>Can High Limit</b> Indicates the high alarm value as a percentage of the can volume. The default is <b>90</b> .
	<b>Can High High Limit</b> Indicates the high high alarm value as a percentage of the can volume. The default is <b>95</b> .
<b>Twin Can Changeover Mode</b>	Indicates whether the system automatically change to a second sampling can. Click ▼ to display all valid values.
	<b>AUTO</b> The sampler automatically changes over to the second can when the first is full.
	<b>MANUAL</b> The sampler pauses sampling when the first can is full, and requires the operator to change the value of Can Selected before sampling continues on the second can. <b>Note:</b> <ul style="list-style-type: none"> <li>▪ If sampling is stopped because both cans are full, the Twin Can Changeover Mode is set to MANUAL by the system. The user must set back to AUTO if required.</li> <li>▪ The display for Twin Can Changeover must be manually added to the displays.</li> </ul>

3. Click in the hierarchy menu when you finish defining settings. A confirmation dialog box displays.
4. Click **Yes** to apply your changes. The PCSetup screen displays.

## 6.6 Gas – Ultrasonic

These stream settings are specific to gas ultrasonic applications. When you initially create a configuration, the calculation selections you make determine which calculation-specific screens appear in the hierarchy menu.



### Caution

**It is extremely unlikely that any one S600+ configuration would contain all the settings discussed in this section. For that reason, several sample configurations demonstrate the settings.**

### 6.6.1 AGA8 (Compressibility)

Compressibility settings define the constants and calculation limits for a range of parameters including pressure, temperature, density, and compressibility factors. This screen displays when you configure the S600+ to use the main AGA8 standard to calculate base compressibility and density, flowing compressibility and density, and standard compressibility for natural gases.

**Note:** “Standard conditions” are assumed as 14.73 psia and 60 °F.

The compressibility settings also allow you to define alarms. The system activates these alarms when the calculated results are not within the specified limits.

1. Select **AGA8** from the hierarchy menu. The AGA8 screen displays.

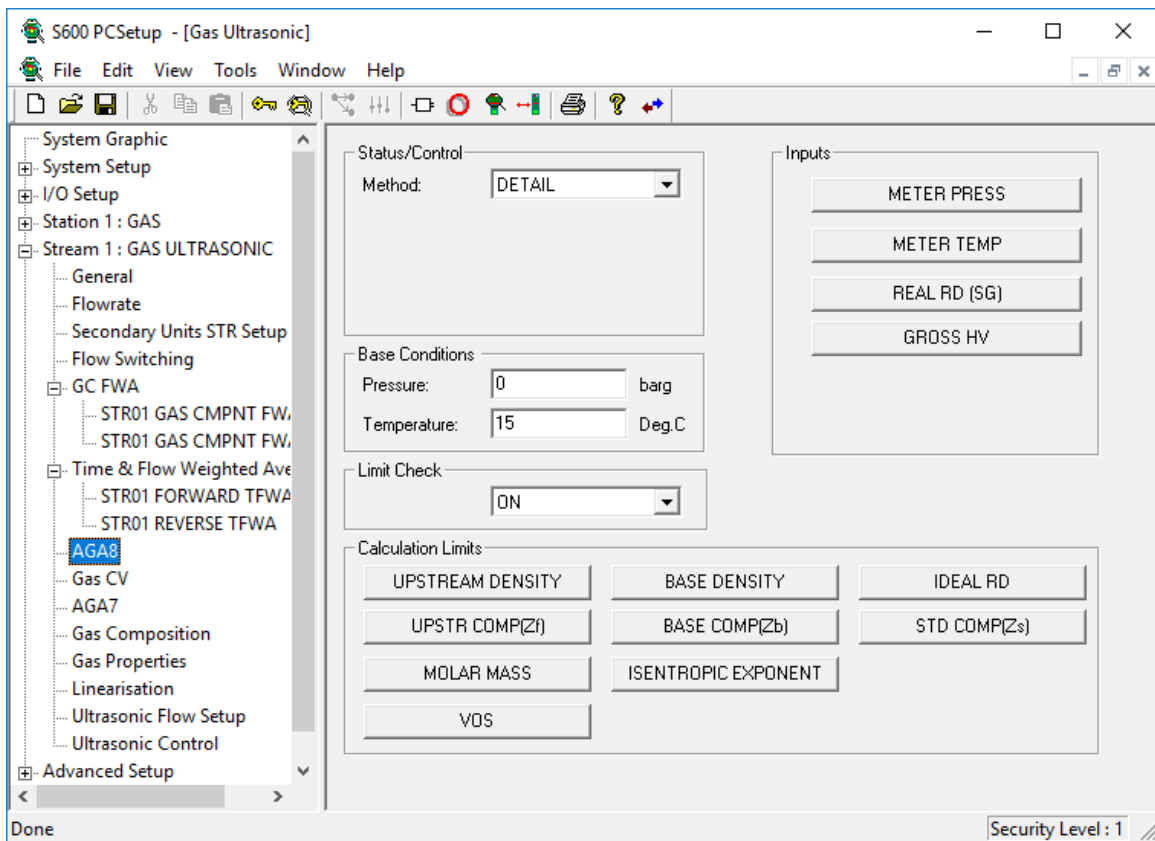

Figure 6-77. AGA8 screen

2. Complete the following fields.

Field	Description
<b>Method</b>	Indicates the compressibility method. Click ▼ to display all valid values.
<b>DETAIL</b>	Uses 21 component values, temperature and pressure in accordance with the 1994 standard. This is the <b>default</b> .

Field	Description
<b>GROSS1</b>	Uses SG, Heating Value, CO <sub>2</sub> , temperature and pressure in accordance with the 1991 standard. <b>Note:</b> Gross1 only supports volumetric heating value and does not support mass heating value.
<b>GROSS2</b>	Uses SG, N <sub>2</sub> , CO <sub>2</sub> , temperature and pressure in accordance with the 1991 standard.
<b>VNIC</b>	Uses 20 component values, temperature and pressure in accordance with GOST 30319 1996.
<b>MGERG</b>	Uses 19 component values (As indicated in GERG Technical Monograph 2 1998) to calculate compressibility of natural gas mixtures based on a full compositional analysis.
<b>PT 1 DETAIL 2017</b>	Uses 21 component values, temperature and pressure in accordance with the 2017 standard.
<b>PT 1 GROSS1 2017</b>	Uses SG, Heating Value, CO <sub>2</sub> , temperature and pressure in accordance with the 2017 standard. <b>Note:</b> Gross1 only supports volumetric heating value and does not support mass heating value.
<b>PT 1 GROSS2 2017</b>	Uses SG, N <sub>2</sub> , CO <sub>2</sub> , temperature and pressure in accordance with the 2017 standard.
<b>PT 1 GROSS0 2017</b>	Uses 21 component values, temperature and pressure in accordance with the 2017 standard.
<b>PT 2 GERG 2008</b>	Uses 21 component values [as indicated in Table 1 AGA8 2017 Part 2 (GERG 2008)] to calculate compressibility of natural gas mixtures based on a full compositional analysis.
<b>Pressure</b>	Sets the pressure at base conditions. The default is <b>0</b> .
<b>Temperature</b>	Sets the temperature at base conditions. The default is <b>15</b> .
<b>Limit Check</b>	Click ▼ to select <b>Off</b> to disable the calculation limit checking. The default is <b>On</b> . <b>Note:</b> The compressibilities and densities will be less accurate and the calculation may fail completely when operating outside the calculation limits.
<b>METER PRESS</b>	Click to display an Analog Inputs dialog box you use to define the analog input values associated with this stream, I/O card, and channel, as well as conversion factors and alarm limits.
<b>METER TEMP</b>	Click to display an Analog Inputs dialog box you use to define the analog input values associated with this stream, I/O card, and channel, as well as conversion factors and alarm limits.

Field	Description
<b>REAL RD (SG)</b>	Click to display a Calculation Result dialog box you use to define the mode, keypad value, and the specific alarm limits for the real relative density.
<b>GROSS HV</b>	Click to display a Calculation Result dialog box you use to define the mode, keypad value, and the specific alarm limits for the gross heating value (HV).

- Click any of the following buttons to set calculation limits:

Button	Description
<b>UPSTREAM DENSITY</b>	Click to display a Calculation Result dialog box you use to define the mode, keypad value, and the specific alarm limits for upstream density.
<b>UPSTR COMP(Zf)</b>	Click to display a Calculation Result dialog box you use to define the mode, keypad value, and the specific alarm limits for upstream compressibility.
<b>MOLAR MASS</b>	Click to display a Calculation Result dialog box you use to define the mode, keypad value, and the specific alarm limits for molar mass.
<b>VOS</b>	Click to display a Calculation Result dialog box you use to define the mode, keypad value, and the specific alarm limits for the velocity of sound. <b>Note:</b> This field is visible <b>only</b> if you select either <b>PT1 DETAIL 2017</b> or <b>PT2 GERG 2008</b> in the <b>Status/Control Method</b> field.
<b>BASE DENSITY</b>	Click to display a Calculation Result dialog box you use to define the mode, keypad value, and the specific alarm limits for base density.
<b>BASE COMP(Zb)</b>	Click to display a Calculation Result dialog box you use to define the mode, keypad value, and the specific alarm limits for base compressibility.
<b>ISENTROPIC EXPONENT</b>	Click to display a Calculation Result dialog box you use to define the mode, keypad value, and the specific alarm limits for the isentropic exponent. <b>Note:</b> This field is visible <b>only</b> if you select either <b>PT1 DETAIL 2017</b> or <b>PT2 GERG 2008</b> in the <b>Status/Control Method</b> field.
<b>IDEAL RD</b>	Click to display a Calculation Result dialog box you use to define the mode, keypad value, and the specific alarm limits for ideal relative density.
<b>STD COMP(Zs)</b>	Click to display a Calculation Result dialog box you use to define the mode, keypad value, and the specific alarm limits for standard compressibility.

- Click in the hierarchy menu when you finish defining settings. A confirmation dialog box displays.
- Click **Yes** to apply your changes. The PCSetup screen displays.

### 6.6.2 Gas CV (ISO6976 or GPA2172/ASTM D3588)

Calorific Value settings define the composition type, table to be used, and calculation limits for a range of parameters including density, relative density, and calorific value. This screen displays when you configure the S600+ to use either the ISO6976 or GPA2172/ASTM D3588 standards (defined in step 5 of the PCSetup Editor's

Configuration Wizard) to calculate the calorific value (heating value) of the gas mixture.

The calorific value settings also allow you to define alarms. The system activates these alarms when the calculated results are not within the specified limits.

1. Select **Gas CV** from the hierarchy menu. The Calorific Value screen displays.

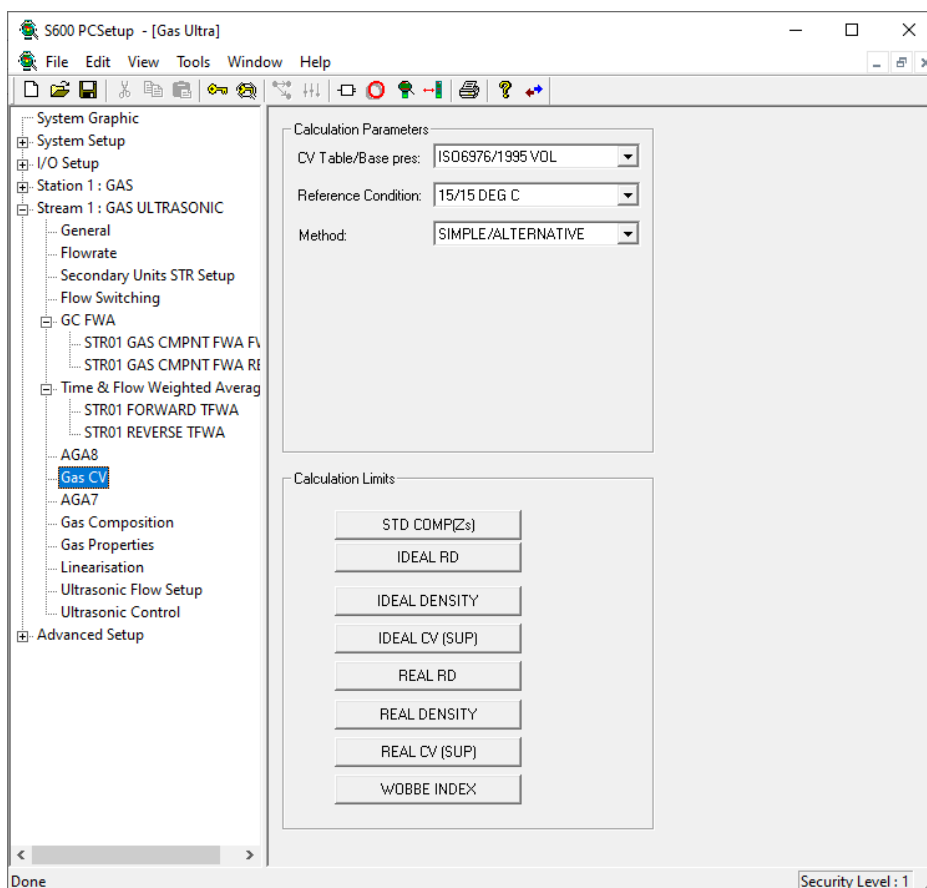

Figure 6-78. Gas CV screen

2. Complete the following fields.

Field	Description
<b>CV Table</b>	Identifies the particular compressibility value the program uses. Click ▼ to display all valid values.
<b>ISO6976/1995 Vol</b>	Calculates CV based on volume, using the 1995 table. This is the <b>default</b> if you choose CV ISO6976 as your initial stream option. <b>Note:</b> This option displays <b>only</b> if you initially configure the stream to use CV ISO6976.
<b>ISO6976/1995 Mass</b>	Calculates CV based on mass, using the 1995 table. <b>Note:</b> This option displays <b>only</b> if you initially configure the stream to use CV ISO6976.

Field	Description
<b>ISO6976/1983 Vol</b>	<p>Calculates CV based on mass, using the 1983 table.</p> <p><b>Note:</b> Support for the 1983 table is limited to superior volumetric at 15/15. This option displays <b>only</b> if you initially configure the stream to use CV ISO6976.</p>
<b>ISO6976/2016 Vol</b>	<p>Calculates CV based on volume, using the 2016 table.</p> <p><b>Note:</b> This option displays <b>only</b> if you initially configure the stream to use CV ISO6976.</p>
<b>ISO6976/2016 Mass</b>	<p>Calculates CV based on mass, using the 2016 table.</p> <p><b>Note:</b> This option displays <b>only</b> if you initially configure the stream to use CV ISO6976.</p>
<b>GPA/2003 AGA (14.73)</b>	<p>Calculates CV based on a base pressure of 14.73 psia. This is the <b>default</b> if you choose CV GPA2172-ASTMD3588 as your initial stream option.</p> <p><b>Note:</b> This option displays <b>only</b> if you initially configure the stream to use <b>CV GPA2172-ASTMD3588</b>.</p>
<b>GPA/2003 ISO (14.696)</b>	<p>Calculates CV based on a base pressure of 14.696 psia.</p> <p><b>Note:</b> This option displays <b>only</b> if you initially configure the stream to use <b>CV GPA2172-ASTMD3588</b>.</p>
<b>GPA/2000 AGA (14.73)</b>	<p>Calculates CV based on a base pressure of 14.73 psia.</p> <p><b>Note:</b> This option displays <b>only</b> if you initially configure the stream to use <b>CV GPA2172-ASTMD3588</b>.</p>
<b>GPA/2000 ISO (14.696)</b>	<p>Calculates CV based on a base pressure of 14.696 psia.</p> <p><b>Note:</b> This option displays <b>only</b> if you initially configure the stream to use <b>CV GPA2172-ASTMD3588</b>.</p>
<b>GPA/1996 AGA (14.73)</b>	<p>Calculates CV based on a base pressure of 14.73 psia.</p> <p><b>Note:</b> This option displays <b>only</b> if you initially configure the stream to use <b>CV GPA2172-ASTMD3588</b>.</p>
<b>GPA/1996 ISO (14.696)</b>	<p>Calculates CV based on a base pressure of 14.696 psia.</p> <p><b>Note:</b> This option displays <b>only</b> if you initially configure the stream to use <b>CV GPA2172-ASTMD3588</b>.</p>



Field	Description
	<p><b>GPA/2016 Pb (14.65)</b> Calculates CV based on a base pressure of 14.65 psia.</p> <p><b>Note:</b> This option displays <b>only</b> if you initially configure the stream to use <b>CV GPA2172-ASTMD3588</b>.</p>
<b>Reference Condition</b>	<p>Indicates the <math>t_1/t_2</math> value, where <math>t_1</math> is the calculation reference temperature for combustion and <math>t_2</math> is the reference condition for metering. The default is <b>15/15 DEG C</b>.</p> <p><b>Note:</b></p> <ul style="list-style-type: none"> <li>▪ For <b>ISO6976 1983 VOL</b> selection, the 60/60F and 15/15.55 Deg C selections are <b>not</b> supported.</li> <li>▪ For <b>ISO6976 1995 VOL</b> and <b>MASS</b> selections, the 60/60F selection refers to a combustion temperature (<math>t_1</math>) of 60 Deg F and a metering temperature (<math>t_2</math>) of 15 Deg C. The 15/15.55 Deg C selection is not supported.</li> </ul> <p><b>Note:</b> For Binary.app versions <b>prior to 06.30a</b>, the 60/60F selection refers to a combustion temperature (<math>t_1</math>) of 15 Deg C and a metering temperature (<math>t_2</math>) of 15 Deg C.</p> <ul style="list-style-type: none"> <li>▪ For <b>ISO6976 2016 VOL</b> and <b>MASS</b> selections, the 60/60F selection refers to a combustion temperature (<math>t_1</math>) of 60 Deg F and a metering temperature (<math>t_2</math>) of 15 Deg C. The 15/15.55 Deg C selection refers to a combustion temperature (<math>t_1</math>) of 15.55 Deg C (60 Deg F) and a metering temperature (<math>t_2</math>) of 15.55 Deg C (60 Deg F).</li> </ul> <p><b>Note:</b> For Binary.app versions <b>prior to 06.30a</b>, the 60/60F selection refers to a combustion temperature (<math>t_1</math>) of 15 Deg C and a metering temperature (<math>t_2</math>) of 15 Deg C.</p>
<b>Method</b>	<p>If you select CV ISO6976 in your initial configuration and you select the 1995 standard, you have the choice of Alternative or Definitive methods (using table 4 Mass / table 5 volume) for calculating the ideal, superior, and inferior CV values. This selection is not applicable to the 1983 or 2016 standards.</p> <p>If you select CV GPA2172-ASTMD3588 in your initial configuration, you have the choice of the Simple (using equation 7 from the GPA2172-ASTMD3588-09 standard) or Rigorous (using equations 8 &amp; 9 from the GPA2172-ASTMD3588-09 standard) methods for calculating the standard compressibility.</p> <p><b>Note:</b> This option is valid <b>only</b> for configurations created with Config600 version 3.1 or greater.</p>
<b>User Temp T2</b>	<p>Applicable to the <b>ISO6976 2016 VOL</b> and <b>ISO6976 2016 MASS</b> selections. Also applicable to <b>ISO6976 1995 VOL</b> selection when the Definitive method is selected.</p> <p><b>Note:</b> It may be necessary to add this item to a display so that it can be correctly initialised.</p>

<b>Field</b>	<b>Description</b>
<b>User Press P2</b>	Applicable to the <b>ISO6976 2016 VOL</b> and <b>ISO6976 1995 VOL</b> selections when the Definitive method is selected. <b>Note:</b> It may be necessary to add this item to a display so that it can be correctly initialised.
<b>Table Revision</b>	This replaces the above AGA and ISO selections in the CV Table field for GPA 2172. You can select the GPA2145 table revision from one of the following: <ul style="list-style-type: none"> <li>▪ 1996</li> <li>▪ 2000</li> <li>▪ 2003</li> <li>▪ 2009</li> </ul> <b>Note:</b> This option is valid <b>only</b> for configurations created with Config600 version 3.1 or greater.
<b>BASE COMP(Zb)</b>	Click to supply an externally calculated base compressibility from another calculation. The system uses the entered value in GPA2172-ASTMD3588 calculations instead of using its own internally calculated value based on the composition input.
<b>Composition Type</b>	Defines the composition input type. Valid options are: <ul style="list-style-type: none"> <li>▪ mass to energy using mole percent</li> <li>▪ mass to energy using mole fraction</li> <li>▪ volume to energy using mole percent</li> <li>▪ volume to energy using mole fraction</li> </ul> <b>Note:</b> This option is valid <b>only</b> for AGA5 configurations.

3. Click any of the following buttons to define ISO6976 or GPA2172/ASTM D3588 calculation limits.

<b>Button</b>	<b>Description</b>
<b>STD COMP(Zs)</b>	Click to display a Calculation Result dialog box you use to define the mode, keypad value, and the specific alarm limits for the calculated standard compressibility (Zs).
<b>IDEAL RD</b>	Click to display a Calculation Result dialog box you use to define the mode, keypad value, and the specific alarm limits for the calculated ideal relative density.
<b>IDEAL DENSITY</b>	Click to display a Calculation Result dialog box you use to define the mode, keypad value, and the specific alarm limits for the calculated ideal density.
<b>IDEAL CV (SUP)</b>	Click to display a Calculation Result dialog box you use to define the mode, keypad value, and the specific alarm limits for ideal calorific value. <b>Note:</b> The superior CV is output to calc field 1 of the CV object and the inferior CV is output to calc field 3. You can select either by the CV object mode from the S600+ front panel.
<b>Gross HV</b>	Click to display a Calculation Result dialog box you use to define the mode, keypad value, and the specific alarm limits for gross heating value. <b>Note:</b> This field displays <b>only</b> if you initially configure the stream to use CV GPA2172-ASTMD3588.

Button	Description
<b>REAL RD</b>	Click to display a Calculation Result dialog box you use to define the mode, keypad value, and the specific alarm limits for real relative density.
<b>REAL DENSITY</b>	Click to display a Calculation Result dialog box you use to define the mode, keypad value, and the specific alarm limits for real density.
<b>REAL CV (SUP)</b>	Click to display a Calculation Result dialog box you use to define the mode, keypad value, and the specific alarm limits for real calorific value. <b>Note:</b> The superior CV is output to calc field 1 of the CV object and the inferior CV is output to calc field 3. You can select either by the CV object mode from the S600+ front panel.
<b>WOBBE INDEX</b>	Click to display a Calculation Result dialog box you use to define the mode, keypad value, and the specific alarm limits for real calorific value. <b>Note:</b> The Wobbe Index is calculated using the Real Superior CV.
<b>REAL VOL IDEAL HV</b>	Click to display a Calculation Result dialog box you use to define the mode, keypad value, and the specific alarm limits for the real volume ideal heating value. <b>Note:</b> This field displays <b>only</b> if you initially configure the stream to use CV GPA2172-ASTMD3588.

- Click in the hierarchy menu when you finish defining settings. A confirmation dialog box displays.
- Click **Yes** to apply your changes. The PCSetup screen displays.

### 6.6.3 AGA7 (Gross Volume Flowrate)

The AGA7 settings define the constants and calculation limits for a range of parameters including meter pressure, temperature, and compressibility. This screen displays when you configure the S600+ to use the AGA7 standards to calculate the gross volume flowrate from a gas turbine.

The AGA7 settings also allow you to define alarms. The system activates these alarms when the calculated results are not within specified limits.

- Select **AGA7** from the hierarchy menu. The AGA7 screen displays.

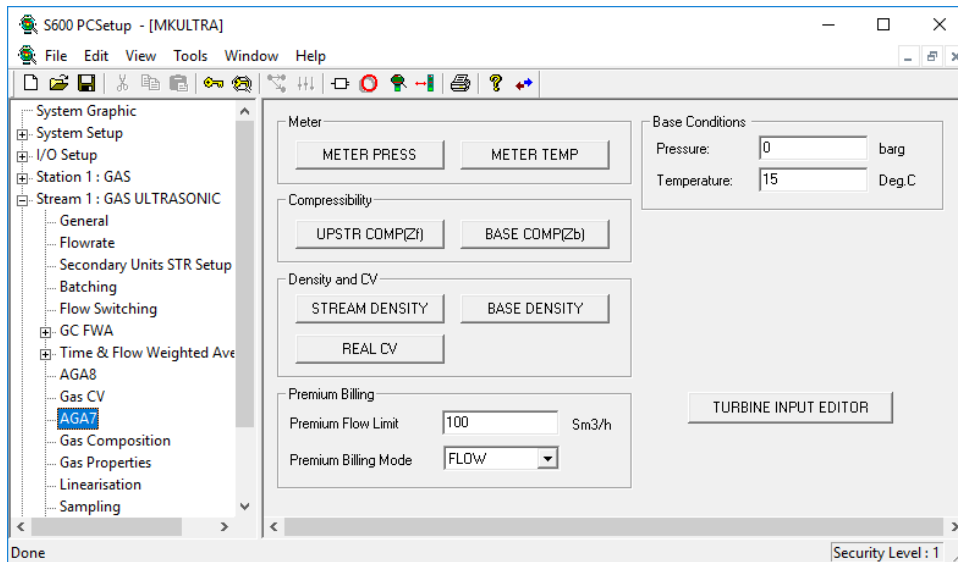

Figure 6-79. AGA7 screen

2. Complete the following fields.

Field	Description
<b>METER PRESS</b>	Click to display an Analog Inputs dialog box you use to define the analog input values associated with this stream, I/O module, and channel, as well as conversion factors and alarm limits.
<b>METER TEMP</b>	Click to display an Analog Inputs dialog box you use to define the analog input values associated with this stream, I/O module, and channel, as well as conversion factors and alarm limits.
<b>UPSTR COMP(Zf)</b>	Click to display a Calculation Result dialog box you use to define the mode, keypad value, and the specific alarm limits for the upstream compressibility (Zf).
<b>BASE COMP(Zb)</b>	Click to display a Calculation Result dialog box you use to define the mode, keypad value, and the specific alarm limits for the base compressibility (Zb).
<b>STREAM DENSITY</b>	Click to display a Calculation Result dialog box you use to define the mode, keypad value, and the specific alarm limits for the stream density.
<b>BASE DENSITY</b>	Click to display a Calculation Result dialog box you use to define the mode, keypad value, and the specific alarm limits for the base density.
<b>REAL CV</b>	Click to display a Calculation Result dialog box you use to define the mode, keypad value, and the specific alarm limits for the real calorific value.
<b>Premium Flow Limit</b>	In Premium Billing FLOW mode, sets a flowrate limit above which the system increments forward premium totals whenever the flowrate exceeds the keypad limit. In Premium Billing TOTAL mode, sets a total limit above which the system increments forward premium totals whenever the period total exceeds the keypad limit. The default is <b>100</b> .
<b>Premium Billing Mode</b>	Indicates the premium total mode, in which the system increments premium totals at the end of a period only if the period total exceeds the keypad limit. Click ▼ to display all valid values. The default is <b>FLOW</b> .
<b>Pressure</b>	Sets pressure at base conditions. The default is <b>0</b> .

Field	Description
<b>Temperature</b>	Sets temperature at base conditions. The default is <b>15</b> .
<b>TURBINE INPUT EDITOR</b>	Click to display the Turbine Inputs screen on the I/O Setup option.

3. Click in the hierarchy menu when you finish defining settings. A confirmation dialog box displays.
4. Click **Yes** to apply your changes. The PCSetup screen displays.

### 6.6.4 Stream Gas Composition (Gas Ultrasonic)

Stream Gas Composition settings define the processing and port telemetry parameters for streams receiving data from the gas chromatograph controller. The chromatograph controller measures the individual component concentrations found in the line gas. The chromatograph controller settings also allow you to define alarms. The system activates these alarms when the calculated results for the chromatograph data are not within specified limits.

1. Select **Gas Composition** from the hierarchy menu. The Gas Composition screen displays.

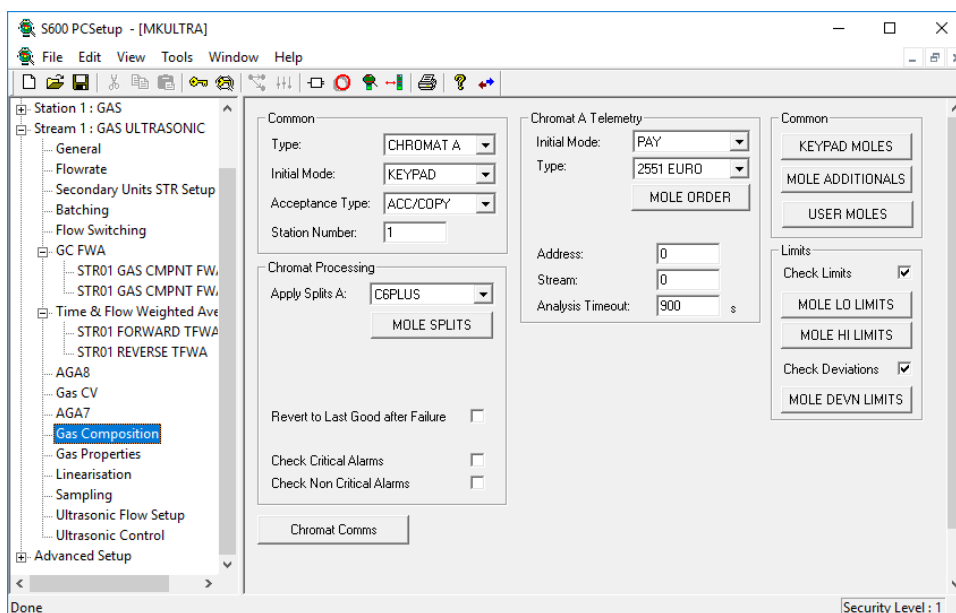

Figure 6-80. Gas Composition screen

2. Complete the following fields.

Field	Description
<b>Type</b>	Indicates the chromatograph configuration. Click ▼ to display all valid values. The default is <b>KP ONLY</b> .
<b>CHROMAT A</b>	Controller-connected; uses keypad data as fallback information.
<b>KP ONLY</b>	Not controller-connected; uses information entered via keypad. This is the <b>default</b> .

**Note:** If you select **KP ONLY**, the system hides a number of fields on this screen.

Field	Description
<b>Initial Mode</b>	Indicates the operational mode for the in-use composition data. Click ▼ to display all valid values.
	<b>KEYPAD</b> Use data entered via keypad. This is the <b>default</b> .
	<b>CHROMAT</b> Use live data from the chromatograph controller.
	<b>DOWNLOAD</b> Download gas composition data directly to each stream. Used only if connected to a remote supervisory computer.
	<b>USER</b> Use customised program for gas composition in S600+.
	<b>KEYPAD_F</b> Start by using keypad-entered data then switch to chromatograph data when a good analysis is received.
<b>Acceptance Type</b>	Indicates how the S600+ manages in-use data. Click ▼ to display all valid values.
	<b>ACC/COPY</b> Copy and normalise keypad data to in-use data only after it is accepted. This is the <b>default</b> .
	<b>ACC/NORM</b> Copy normalised keypad data to in-use data after it is accepted.
	<b>AUTO/NORM</b> Automatically copy normalised keypad data to in-use data.
<b>Station Number</b>	Sets the station associated with this stream. The default is 1.
<b>Apply Splits</b>	Indicates the type of analyser connected to the S600+. For a C6+ analyser, use the C6Plus option. Click ▼ to display all valid values. The default is <b>NO SPLITS</b> . If you select any value other than <b>NO SPLITS</b> , the system displays the <b>MOLE SPLITS</b> button. Use it to define the specific percentage splits for the gases. <b>Note:</b> This field displays <b>only</b> if you select <b>CHROMAT A</b> as the chromatograph configuration type.
<b>MOLE SPLITS</b>	Click to display a dialog box you use to define the specific percentage splits for the gases. <b>Note:</b> This button displays <b>only</b> if you select any value other than <b>NO SPLITS</b> .
<b>Revert to Last Good after Failure</b>	Continues using the last good composition in the event of failure. Otherwise the system reverts to keypad data. <b>Note:</b> This field displays <b>only</b> if you select <b>CHROMAT A</b> as the chromatograph configuration type.
<b>Check Critical Alarms</b>	Marks the received composition as failed if any critical alarm is set (such as the pre-amp fail on the Danalyzer for a Daniel 2551 Controller). <b>Note:</b> This field displays <b>only</b> if you select <b>CHROMAT A</b> as the chromatograph configuration type.
<b>Check Non Critical Alarms</b>	Marks the received composition as failed if any non-critical alarm is set (such as the pre-amp fail on the Danalyzer for a Daniel 2551 Controller). <b>Note:</b> This field displays <b>only</b> if you select <b>CHROMAT A</b> as the chromatograph configuration type.

Field	Description
<b>CHROMAT COMMS</b>	Click to display the Comm screen in I/O Setup (see <i>Chapter 4, Section 4.10</i> ).
<b>Initial Mode</b>	Identifies the chromatograph and any fallback controllers. Currently, the only valid value is <b>PAY</b> , which indicates one chromatograph and no fallback controller. <b>Note:</b> This field displays <b>only</b> if you select <b>CHROMAT A</b> as the chromatograph configuration type.
<b>Type</b>	Indicates the type of chromatograph controller. Click ▼ to display all valid values. <b>Note:</b> This field displays <b>only</b> if you select <b>CHROMAT A</b> as the chromatograph configuration type.
<b>2551 EURO</b>	S600+ is connected to a Daniel 2551 (European) controller. This is the <b>default</b> .
<b>2350 EURO</b>	S600+ is connected to a Daniel 2350 (European) controller set in SIM_2251 mode.
<b>2350 USA</b>	S600+ is connected to a Daniel 2350 (USA) controller set in SIM_2251 mode.
<b>2251 USA</b>	S600+ is connected to a Daniel 2251 controller.
<b>Generic</b>	S600+ is connected to another type of controller.
<b>Siemens</b>	S600+ is connected to a Siemens Advance Maxum via a Siemens Network Access Unit (NAU).
<b>MOLE ORDER</b>	Click this button to display a dialog box on which you indicate the order in which the gas composition information comes into the S600+ via telemetry. <b>0</b> indicates any component which is <b>not</b> included in the Modbus map. <b>Note:</b> <ul style="list-style-type: none"> <li>▪ This button displays <b>only</b> if you select <b>Generic</b> as a Type. Additionally, The Modbus map you create must be compatible with the controlled to which the S600+ is connected. Refer to <i>Chapter 14, Modbus Editor</i>, for further information.</li> <li>▪ This field displays <b>only</b> if you select <b>CHROMAT A</b> as the chromatograph configuration type.</li> <li>▪ This field is applicable <b>only</b> if you select <b>Siemens</b> or <b>Generic</b> in the Type field.</li> </ul>
<b>Address</b>	Configures multi-drop chromatograph support. <b>Do not change unless advised to do so.</b> <b>Note:</b> This field displays <b>only</b> if you select <b>CHROMAT A</b> as the chromatograph configuration type.
<b>Stream</b>	Sets the chromat analysis stream assigned to this metering stream. The default is <b>0</b> . <b>Note:</b> This field displays <b>only</b> if you select <b>CHROMAT A</b> as the chromatograph configuration type. If you need to support more than one stream, contact Technical Support.

<b>Field</b>	<b>Description</b>
<b>Analysis Timeout</b>	<p>Sets the maximum number of seconds the S600+ waits to receive a new composition from the chromatograph controller before raising an alarm. The default is <b>900</b>.</p> <p><b>Note:</b> This field displays <b>only</b> if you select <b>CHROMAT A</b> as the chromatograph configuration type.</p>
<b>Download Timeout</b>	<p>Sets the maximum number of minutes the S600+ waits to receive a new composition from the supervisory computer before raising a <b>DL Timeout Alarm</b>. The default is <b>15</b>.</p> <p><b>Note:</b></p> <ul style="list-style-type: none"> <li>▪ A value of <b>0</b> disables the timeout.</li> <li>▪ This field displays <b>only</b> if you select <b>KP ONLY</b> in the Common Type field.</li> </ul>
<b>KEYPAD MOLES</b>	<p>Click to display a dialog box you use to define mole percentage values for each gas component.</p> <p><b>Note:</b> The system assumes the keypad composition adds to 100% (normalised) when the Acceptance Type is ACC/COPY. If you select <b>ACC/NORM</b> or <b>AUTO/NORM</b>, the system automatically normalises the keypad composition.</p>
<b>MOLE ADDITIONAL</b>	<p>Click to display a dialog box you use to define mole percentage values for gas components not analysed by the Danalyzer. The system assumes any additional components to be normalised values, and the analyser components are re-normalized (100 – sum of additional components).</p> <p><b>Note:</b> This field displays <b>only</b> if you select <b>CHROMAT A</b> as the chromatograph configuration type.</p>
<b>USER MOLES</b>	<p>Click to display a dialog box you use to define mole percentage values for each gas component. The system assumes user moles to be normalised.</p> <p><b>Note:</b> The S600+ uses these values <b>only</b> if you set the Initial Mode to <b>USER</b>. A Modbus download from another computer may overwrite these values on a running configuration.</p>
<b>Check Limits</b>	<p>Enables limit checking on each gas component. When you select this check box, the <b>MOLE LO LIMITS</b> and <b>MOLE HI LIMITS</b> buttons display.</p>



Field	Description
<b>MOLE LO LIMITS</b>	<p>Click to display a dialog box you use to define low mole percentage limit values for each gas component. Enter <b>0</b> in any field to prevent the test for the selected component.</p> <p><b>Note:</b></p> <ul style="list-style-type: none"> <li>The system uses the values you enter through these buttons <b>only</b> if you select the Check Limits check box. The system applies this test to the keypad, downloaded, user, additional, and new analysis components. When enabled, the system applies the limit check against the high and low limits. Limits are considered valid if the limit is greater than zero (0). The system also applies the check to the Total field. If you <b>disable</b> the limit check, the keypad, downloaded and user Total field must lie within 0.1% and 150%. A sum of the new analysis must be within 99.5% and 100.5%.</li> <li>This field displays <b>only</b> if you place a check mark in the Check Limits field.</li> </ul>
<b>MOLE HI LIMITS</b>	<p>Click to display a dialog box you use to define high mole percentage limit values for each gas component. Enter <b>0</b> in any field to prevent the test for the selected component.</p> <p><b>Note:</b> See note in the description of the Mole Lo Limits field.</p>
<b>Check Deviations</b>	<p>Enables checking on the deviation from the last good analysis for each component. When you select this check box, the <b>MOLE DEVN LIMITS</b> button displays.</p> <p><b>Note:</b> This field displays <b>only</b> if you select <b>CHROMAT A</b> as the chromatograph configuration type.</p>
<b>MOLE DEVN LIMITS</b>	<p>Click to display a dialog box you use to define the maximum deviation allowed for each gas component. Enter <b>0</b> in any field to prevent the test for the selected component.</p> <p><b>Note:</b> This field displays <b>only</b> if you place a check mark in the Check Deviations field.</p>

- Click in the hierarchy menu when you finish defining settings. A confirmation dialog box displays.
- Click **Yes** to apply your changes. The PCSetup screen displays.

### 6.6.5 Gas Properties (Gas Ultrasonic)

Gas Properties settings define methods the system uses to calculate viscosity, isentropic exponent (also known as “specific heat ratio” or “adiabatic exponent”), and the velocity of sound.

These settings also allow you to define alarms. The system activates these alarms when the calculated results are not within the specified limits.

- Select **Gas Properties** from the hierarchy menu. The Gas Properties screen displays.

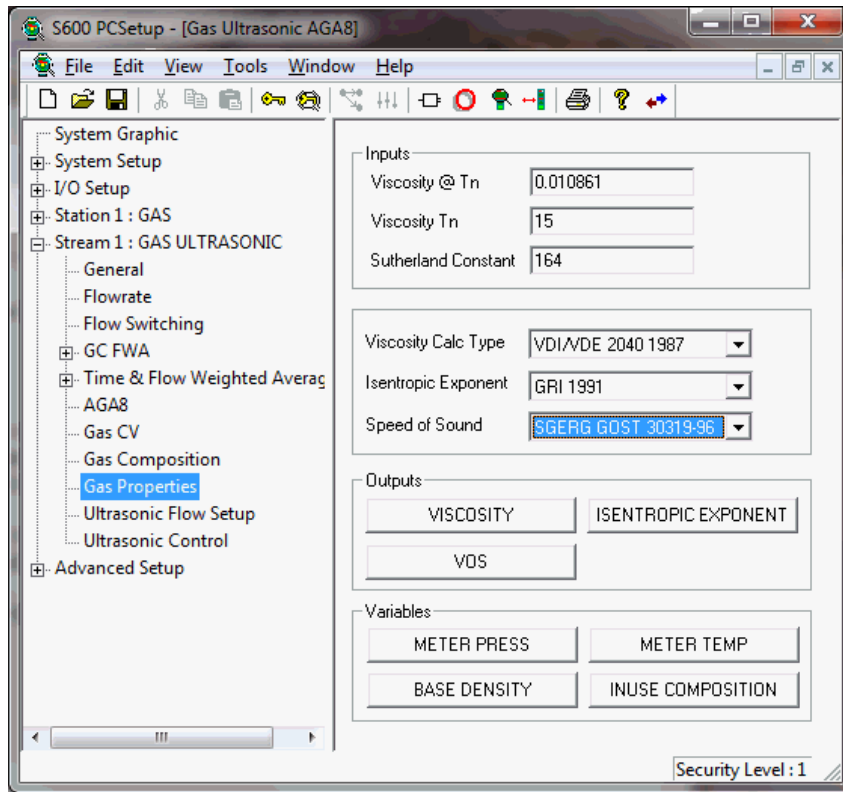

Figure 6-81. Gas Properties screen

2. Complete the following fields.

Field	Description
<b>Viscosity @ Tn</b>	Sets the reference viscosity for the gas. The default is <b>0.010861</b> . <b>Note:</b> Used <b>only</b> by VDI/VDE.
<b>Viscosity Tn</b>	Sets the reference viscosity temperature for the gas. The default is <b>15</b> . <b>Note:</b> Used <b>only</b> by VDI/VDE.
<b>Sutherland Constant</b>	Sets the Sutherland constant for the gas. The default is <b>164</b> . <b>Note:</b> Used <b>only</b> by VDI/VDE.
<b>Viscosity Calc Type</b>	Indicates the method for calculating the viscosity of the gas. Click ▼ to display all valid values.
<b>Disabled</b>	Value not calculated; defaults to keypad-entered value. This is the <b>default</b> .
<b>SGERG GOST 30139-2015</b>	Uses calculations from GOST 30139-2015. Requires base density, N <sub>2</sub> , and CO <sub>2</sub> inputs.
<b>VDI/VDE 2040 1987</b>	Uses calculations from VDI/VDE 2040 Part 2 1987. Requires viscosity @T <sub>n</sub> , viscosity T <sub>n</sub> , and Sutherland Constant inputs.
<b>VNIC GOST 30319-2015</b>	Uses calculations from GOST 30319-2015. Requires full gas composition input.

Field	Description
<b>Isentropic Exponent</b>	Indicates the method for calculating the isentropic exponent of the gas. Click ▼ to display all valid values.
	<b>AGA10 2003</b> Uses calculations from AGA10 2003. Requires full gas composition input.
	<b>Disabled</b> Value not calculated; defaults to keypad-entered value. This is the <b>default</b> .
	<b>GRI 1991</b> Uses calculations from GRI 1991. Requires full gas composition input.
	<b>SGERG GOST 30139-2015</b> Uses calculations from GOST 30139-2015. Requires Base Density, N <sub>2</sub> and CO <sub>2</sub> inputs.
	<b>VNIC GOST 30319-2015</b> Uses calculations from GOST 30319-2015. Requires full gas composition input.
<b>Speed of Sound</b>	Indicates the method for calculating the speed of sound. Click ▼ to display all valid values.
	<b>AGA10 2003</b> Uses calculations from AGA10 2003. Requires full gas composition input.
	<b>Disabled</b> Value not calculated; defaults to keypad-entered value. This is the <b>default</b> .
	<b>GRI 1991</b> Uses calculations from GRI 1991. Requires full gas composition input.
	<b>SGERG GOST 30139-2015</b> Uses calculations from GOST 30139-2015. Requires Base Density, N <sub>2</sub> and CO <sub>2</sub> inputs.
	<b>VNIC GOST 30319-2015</b> Uses calculations from GOST 30319-2015. Requires full gas composition input.

- Click any of the following buttons to define gas property outputs or variables.

Button	Description
<b>VISCOSITY</b>	Click to display a Calculation Result dialog box you use to define the mode, keypad value, and the specific alarm limits for viscosity.
<b>ISENTROPIC EXPONENT</b>	Click to display a Calculation Result dialog box you use to define the mode, keypad value, and the specific alarm limits for the isentropic exponent.
<b>VOS</b>	Click to display a Calculation Result dialog box you use to define the mode, keypad value, and the specific alarm limits for the velocity of sound (VOS). <b>Note:</b> AGA10 refers to VOS as “speed of sound.”
<b>LINE PRESS</b>	Click to display a Calculation Result dialog box you use to define the mode, keypad value, and the specific alarm limits for line pressure. <b>Note:</b> This button may be disabled on some applications.
<b>LINE TEMP</b>	Click to display a Calculation Result dialog box you use to define the mode, keypad value, and the specific alarm limits for line temperature. <b>Note:</b> This button may be disabled on some applications.

Button	Description
<b>BASE DENSITY</b>	Click to display a Calculation Result dialog box you use to define the mode, keypad value, and the specific alarm limits for base density.
<b>INUSE COMPOSITION</b>	Click to display a <b>read-only</b> table of gas compositions. This corresponds to the table defined using the Gas Composition screen's <b>KEYPAD MOLES</b> button.

4. Click in the hierarchy menu when you finish defining settings. A confirmation dialog box displays.
5. Click **Yes** to apply your changes. The PCSetup screen displays.

### 6.6.6 Local Units

This option allows you to override the global K-factor unit, since a gas application may have more than one type of meter, each using different K-factor units.

1. Select **Local Units** from the hierarchy menu. The Local Units screen displays.

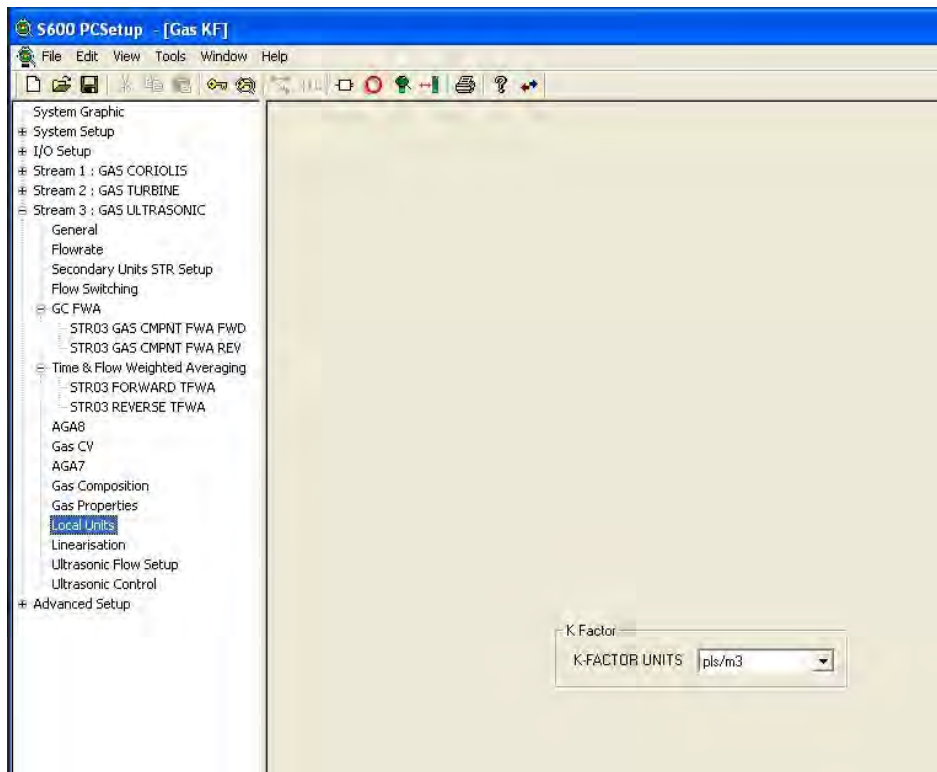

Figure 6-82. Local Units screen

2. Complete the following field.

Field	Description
<b>K-Factor Units</b>	Indicates the type of units to use and override the system K-factor units of measurement. Click ▼ to display all valid values. The default is <b>SYSTEM UNITS</b> . <b>Note:</b> If you select <b>System Units</b> , the stream uses the global default value.

3. Click in the hierarchy menu when you finish defining settings. A confirmation dialog box displays.
4. Click **Yes** to apply your changes. The PCSetup screen displays.

### 6.6.7 Linearisation

Linearisation settings define the constants and calculation limits for the meter factor and K factor. The S600+ calculates a meter factor corresponding to the frequency by interpolating the frequency between fixed points and then cross-referencing the result against a lookup table. Linearisation settings also allow you to define alarms. The system activates these alarms when the calculated results for the meter factor are not within specified limits.

---

**Notes:**

- The linearisation curve for Gas Ultrasonic configurations uses frequency as the default input for Meter Factor calculations. The ability to change the default is available **only** with Config600 Pro software.
- Batching systems that employ meter factor with retrospective meter factor assume that the adjusted value has a “keypad” mode.
- To prevent the live metering system from applying a double correction, use **either** a calculated meter factor **or** a calculated K-factor linearisation (that is, only one factor should have a calculated mode).

- 
1. Select **Linearisation** from the hierarchy menu. The Linearisation screen displays.

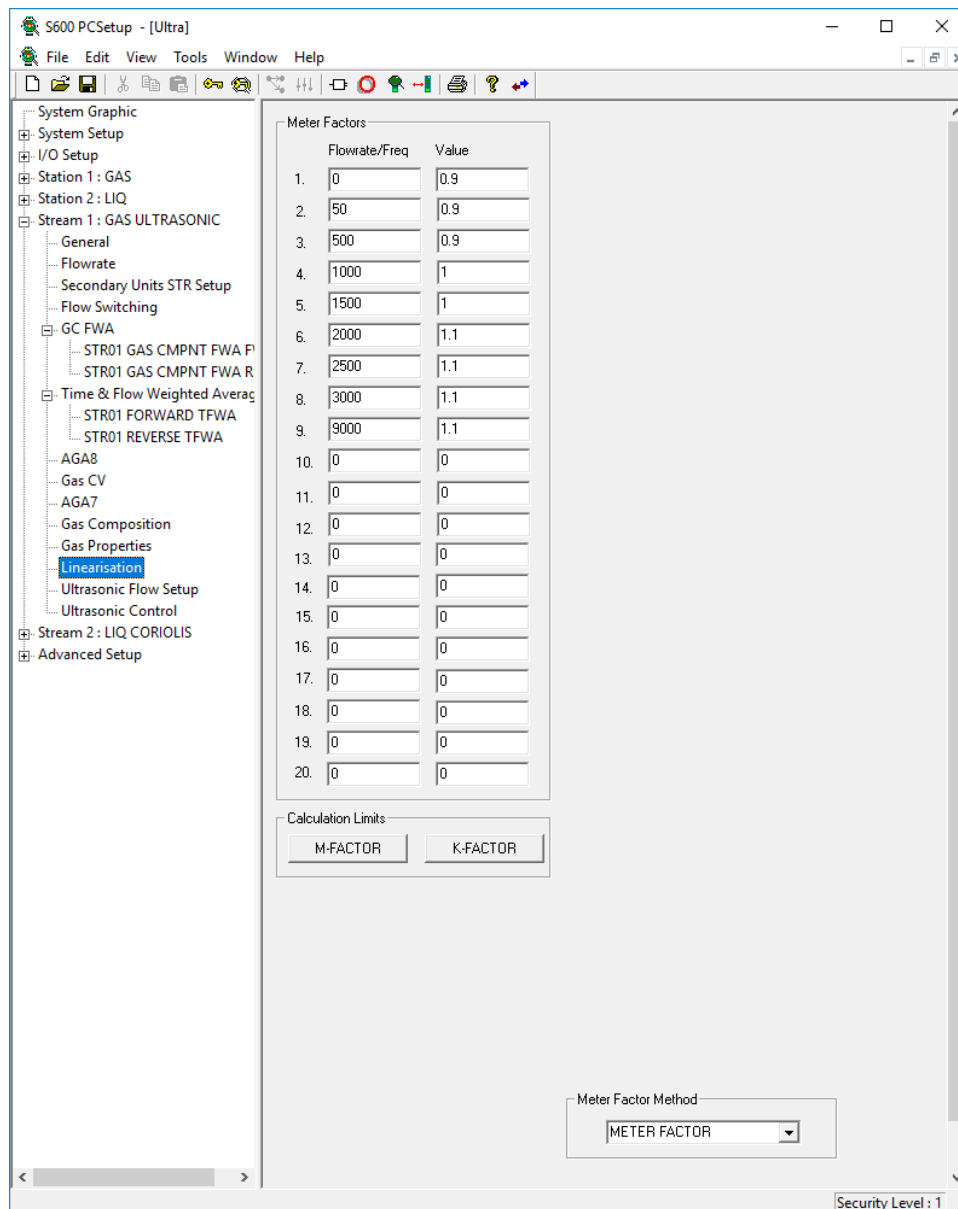

Figure 6-83. Linearisation screen

- Complete the following field.

Field	Description
<b>Meter Factors</b>	Sets up to 10 flow rate and values for the meter corrector factors.
	<b>Flowrate/Freq</b> Sets the flowrate and frequency for each of the meter correction factors.
	<b>Value</b> Sets the corresponding values for each of the meter correction factors.
<b>M-FACTOR</b>	Click to display a Calculation Result dialog box you use to define the mode, keypad value, and the specific alarm limits for the respective factor.
<b>K-FACTOR</b>	Click to display a Calculation Result dialog box you use to define the mode, keypad value, and the specific alarm limits for the respective factor.
<b>Meter Factor Method</b>	Selectable between METER FACTOR (values entered as normal) and ERROR PERCENT (Meter Factor entered as a percentage).

- Click in the hierarchy menu when you finish defining settings. A confirmation dialog box displays.
- Click **Yes** to apply your changes. The PCSetup screen displays.

### 6.6.8 Sampling

Sampling defines the method and interval period for sampling product from a flowing pipeline. By default, Config600 supports one sampler per stream. Config600 uses the following stages during the sampling process:

Stage	Description
<b>0</b>	Idle
<b>1</b>	Monitor
<b>2</b>	Digout n
<b>3</b>	Min Intvl
<b>4</b>	Post Pulse
<b>5</b>	Stopped Manually
<b>6</b>	Stopped Can Full
<b>7</b>	Stopped Low Flow
<b>8</b>	Initial Time
<b>9</b>	Check Flow Switch
<b>10</b>	Stopped Flow Switch
<b>11</b>	Stopped Press Switch
<b>12</b>	Stopped initialise
<b>13</b>	Can Switch Over

**Note:** Batch auto-resets the sampler at the start of the batch.

- Select **Sampling** from the hierarchy menu. The Sampling screen displays.

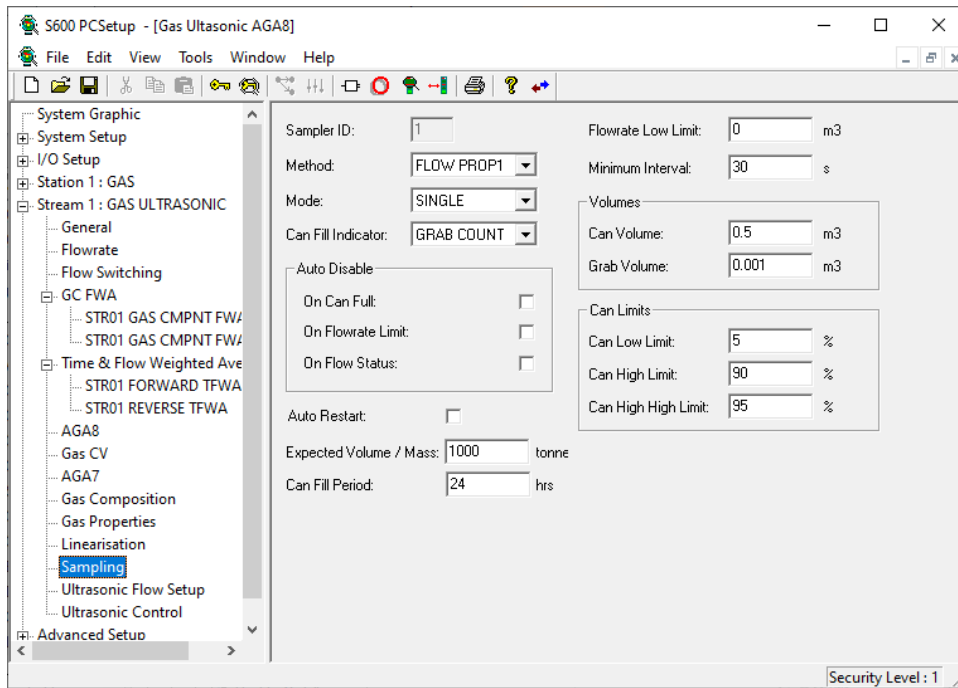

Figure 6-84. Stream Sampling screen

6. Complete the following fields.

Field	Description
<b>Sampler ID</b>	Provides an identifying label for the sampler. Each stream or station must have a unique sampler ID and must be greater than zero.
<b>Method</b>	Indicates the sampling method. Click ▼ to display all valid values.
<b>TIME PROP</b>	Divides the value in the Can Fill Period field by the number of grabs needed to fill the can (derived from the Can Volume and Fill Volume values) to determine a time interval per pulse. This is the <b>default</b> .
<b>FLOW PROP1</b>	Divides the value in the Volume field by the number of grabs needed to fill the can (derived from the Can Volume and Fill Volume values) to determine a volume throughput per pulse.
<b>FLOW PROP2</b>	Uses the value in the Volume field as the volume throughput per pulse.
<b>FLOW PROP3</b>	Uses the value in the Volume field as the volume throughput per pulse, but supports low pressure digital input and pump prime output.



<b>Field</b>	<b>Description</b>
<b>Mode</b>	Indicates the sampling mode. Click ▼ to display all valid values. The S600+ uses Can 1 or Can 2.
	<b>SINGLE</b> Acquire sample in one trial. This is the <b>default</b> .
	<b>DUAL</b> Acquire samples in two trials. <b>Note:</b> If you select <b>Dual</b> , the sampler switches to a second can when the current can is full (according to the two can switchover mode).
<b>Can Fill Indicator</b>	Indicates when the sampling can is full. Click ▼ to display all valid values.
	<b>GRAB COUNT</b> Uses the number of pulses output to the sampler to determine when the sample is full. This is the <b>default</b> .
	<b>DIG I/P</b> Uses a digital input to determine when the sampler is full.
	<b>ANALOG I/P</b> Uses an analog input to determine when the sampler is full.
<b>Auto Disable</b>	Indicates the event at which the system automatically disables the sampling process. Select the appropriate check box to identify the specific event.
	<b>On Can Full</b> Disables the sampling process when the can is full. This is the <b>default</b> .
	<b>On Flowrate Limit</b> Disables the sampling process when the flowrate is less than the value of the Flowrate Low Limit.
	<b>On Flow Status</b> Disables the sampling process when the flow status value is not on-line.
<b>Auto Restart</b>	Automatically restarts (if selected) sampling following an automatic disabling.
<b>Expected Volume/Mass</b>	Indicates, in cubic meters, the expected flow volume or mass of the sampling can. This is the value the Flow Prop1 and Flow Prop2 sampling methods use for calculations. The default is <b>1000</b> .
<b>Can Fill Period</b>	Sets, in hours, the time required to fill the sampling can. The default is <b>24</b> .
	<b>Note:</b> The Time Prop sampling method uses this value for its calculations.
<b>Flowrate Low Limit</b>	Indicates flowrate low limit used by the Auto Disable on Flowrate Limit option. The default is <b>0</b> . <b>Note:</b> This field is required if you select the On Flowrate Limit check box for Auto Disable.
<b>Minimum Interval</b>	Indicates, in seconds, the minimum amount of time between grabs. This is the value the Time Prop sampling method uses for its calculations. The default is <b>30</b> . <b>Note:</b> If the sample exceeds this limit, the system sets the overspeed alarm and increments the overspeed counter.

Field	Description
<b>Volumes</b>	
<b>Can Volume</b>	Indicates, in cubic meters, the volume of the sampling can. The default is <b>0.5</b> .
<b>Grab Volume</b>	Indicates, in cubic meters, the volume of the sampling grab. The default is <b>0.001</b> .
<b>Can Limits</b>	
<b>Can Low Limit</b>	Indicates the low alarm value as a percentage of the can volume. The default is <b>5</b> .
<b>Can High Limit</b>	Indicates the high alarm value as a percentage of the can volume. The default is <b>90</b> .
<b>Can High High Limit</b>	Indicates the high high alarm value as a percentage of the can volume. The default is <b>95</b> .
<b>Twin Can Changeover Mode</b>	Indicates whether the system automatically change to a second sampling can. Click ▼ to display all valid values.
<b>AUTO</b>	The sampler automatically changes over to the second can when the first is full.
<b>MANUAL</b>	The sampler pauses sampling when the first can is full, and requires the operator to change the value of Can Selected before sampling continues on the second can. <b>Note:</b> <ul style="list-style-type: none"> <li>▪ If sampling is stopped because both cans are full, the Twin Can Changeover Mode is set to MANUAL by the system. The user must set back to AUTO if required.</li> <li>▪ The display for Twin Can Changeover must be manually added to the displays.</li> </ul>

7. Click in the hierarchy menu when you finish defining settings. A confirmation dialog box displays.
8. Click **Yes** to apply your changes. The PCSetup screen displays.

### 6.6.9 Ultrasonic Flow Setup

The Ultrasonic flow meter settings define the primary inputs, calculation limits, and spool values for flowrate data received from a Daniel or an Instromet Q.Sonic ultrasonic meter.

These settings also allow you to define alarms. The system activates these alarms when the calculated results for the flowrates are not within specified limits.

1. Select **Ultrasonic Flow Setup** from the hierarchy menu. The Ultrasonic Flow Setup screen displays.

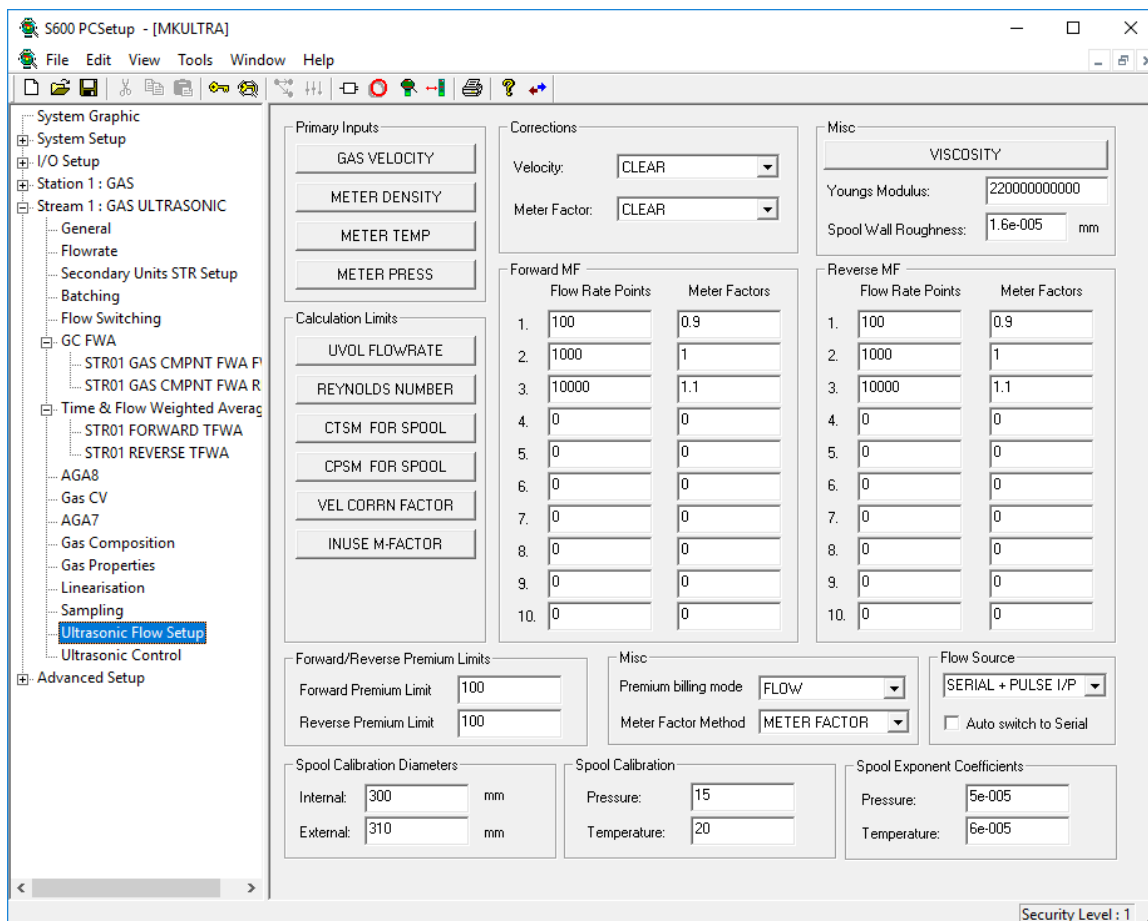

Figure 6-85. Ultrasonic Flow Setup screen

2. Click any of the following buttons to define primary inputs and calculation limits for the ultrasonic flow.

Button	Description
<b>GAS VELOCITY</b>	Click to display a Calculation Result dialog box you use to define the mode, keypad value, and the specific alarm limits for gas velocity.
<b>METER DENSITY</b>	Click to display a Calculation Result dialog box you use to define the mode, keypad value, and the specific alarm limits for meter density.
<b>METER TEMP</b>	Click to display a Calculation Result dialog box you use to define the mode, keypad value, and the specific alarm limits for meter temperature.
<b>METER PRESS</b>	Click to display a Calculation Result dialog box you use to define the mode, keypad value, and the specific alarm limits for meter pressure.
<b>UVOL FLOWRATE</b>	Click to display a Calculation Result dialog box you use to define the specific alarm limits for uncorrected volume flowrate.
<b>REYNOLDS NUMBER</b>	Click to display a Calculation Result dialog box you use to define the specific alarm limits for the Reynolds Number.

Button	Description
<b>CTSM FOR SPOOL</b>	Click to display a Calculation Result dialog box you use to define the mode, keypad value, and the specific alarm limits for the correction factor for the effects of temperature on the spool.
<b>CPSM FOR SPOOL</b>	Click to display a Calculation Result dialog box you use to define the mode, keypad value, and the specific alarm limits for the correction factor for the effects of pressure on the spool.
<b>VEL CORR FACTOR</b>	Click to display a Calculation Result dialog box you use to define the specific alarm limits for the velocity correction factor. <b>Note:</b> This value is used <b>only</b> for JuniorSonic meters.
<b>INUSE M-FACTOR</b>	Click to display a Calculation Result dialog box you use to define the mode, keypad value, and the specific alarm limits for the in-use meter factor.

3. Complete the following fields.

Field	Description
<b>Velocity</b>	Indicates a velocity correction factor. Click ▼ to display all valid values. The default is <b>SET</b> . <b>Note:</b> This velocity correction factor applies <b>only</b> to the JuniorSonic meters.
<b>Meter Factor</b>	Indicates a meter correction factor. Click ▼ to display all valid values. The default is <b>CLEAR</b> . <b>Note:</b> This velocity correction factor applies <b>only</b> to the JuniorSonic meters.
<b>Flow Rate Points (Forward MF)</b>	Sets up to 10 flow rate points for forward meter factor linearisation.
<b>Meter Factors (Forward MF)</b>	Sets up to 10 meter factor values for forward meter factor linearisation. <b>Note:</b> If the Meter Factor Method is <b>ERROR PERCENT</b> , enter the meter factors as a percentage.
<b>VISCOSITY</b>	Click to display a Calculation Result dialog box you use to define the mode, keypad value, and the specific alarm limits for viscosity of the metered product.
<b>Youngs Modulus</b>	Sets the value for the Youngs Modulus of the meter spool. Default value is <b>22000000000</b> .
<b>Spool Wall Roughness</b>	Sets the value for the roughness of the spool wall. Default is <b>1.6e-005</b> .
<b>Flow Rate Points (Reverse MF)</b>	Sets up to 10 flow rate points for reverse meter factor linearisation.
<b>Meter Factors (Reverse MF)</b>	Sets up to 10 meter factor values for reverse meter factor linearisation. <b>Note:</b> If the Meter Factor Method is <b>ERROR PERCENT</b> , enter the meter factors as a percentage.

Field	Description
<b>Forward Premium Limit</b>	In Premium Billing FLOW mode and Flow Direction FORWARD, sets a flowrate limit above which the system increments forward premium totals whenever the flowrate exceeds the keypad limit. In Premium Billing TOTAL mode and Flow Direction FORWARD, sets a total limit above which the system increments forward premium totals whenever the period total exceeds the keypad limit. The default is <b>100</b> .
<b>Reverse Premium Limit</b>	In Premium Billing FLOW mode and Flow Direction REVERSE, sets a flowrate limit above which the system increments reverse premium totals whenever the flowrate exceeds the keypad limit.  In Premium Billing TOTAL mode and Flow Direction REVERSE, sets a total limit above which the system increments reverse premium totals whenever the period total exceeds the keypad limit. The default is <b>100</b> .
<b>Premium Billing Mode</b>	Indicates the premium total mode, in which the system increments premium totals at the end of the hour only if the hourly total exceeds the keypad limit. Click ▼ to display all valid values. <b>FLOW</b> In Premium Billing Flow mode, the system increments premium totals whenever the flowrate exceeds the keypad limit. This is the <b>default</b> . <b>TOTAL</b> In Premium Billing Total mode, the system increments premium totals whenever the period total exceeds the keypad limit.
<b>Meter Factor Method</b>	Indicates the method used to linearise the meter factor. Click ▼ to display all valid values. <b>ERROR PERCENT</b> Interpolate between the two nearest percentage error values in the linearisation table. <b>METER FACTOR</b> Interpolate between the two nearest Meter Factors in the linearisation table. This is the <b>default</b> .
<b>FlowSource</b>	Indicates the source for generating flowtotals. Possible options are: <b>SERIAL</b> Use the serial communication link. This is the <b>default</b> . <b>PULSE I/P</b> Use the pulse input. <b>SERIAL + PULSE I/P</b> Use the serial communications link as default and switch to the pulse input if a fault is detected. <b>Note:</b> This option requires both a serial interface and pulse input to be configured.
<b>Auto Switch to Serial</b>	If selected, the S600+ will revert to using serial communications once available. <b>Note:</b> This option is available <b>only</b> if you select SERIAL + PULSE I/P in the Flow Source.
<b>Internal</b>	Sets the internal diameter of the spool for calibration calculations. The default is <b>300</b> .

Field	Description
<b>External</b>	Sets the external diameter of the spool for calibration calculations. The default is <b>310</b> .
<b>Pressure (Spool Calibration)</b>	Sets the spool pressure for calibration calculations. The default is <b>15</b> .
<b>Temperature (Spool Calibration)</b>	Sets the spool temperature for calibration calculations. The default is <b>20</b> .
<b>Pressure (Spool Exponent)</b>	Sets the exponent coefficients for pressure calculations. The default is <b>5e-005</b> . <b>Note:</b> This field is <b>not</b> used in Daniel calculations.
<b>Temperature (Spool Exponent)</b>	Sets the temperature coefficients for pressure calculations. The default is <b>6e-005</b> .

4. Click in the hierarchy menu when you finish defining settings. A confirmation dialog box displays.
5. Click **Yes** to apply your changes. The PCSetup screen displays.

### 6.6.10 Ultrasonic Control

The Ultrasonic Control settings define the input parameters and calculation limits for interfacing to the Daniel Gas ultrasonic meter.

These settings also allow you to define alarms. The system activates these alarms when the calculated results are not within specified limits.

1. Select **Ultrasonic Control** from the hierarchy menu. The Ultrasonic Control screen displays.

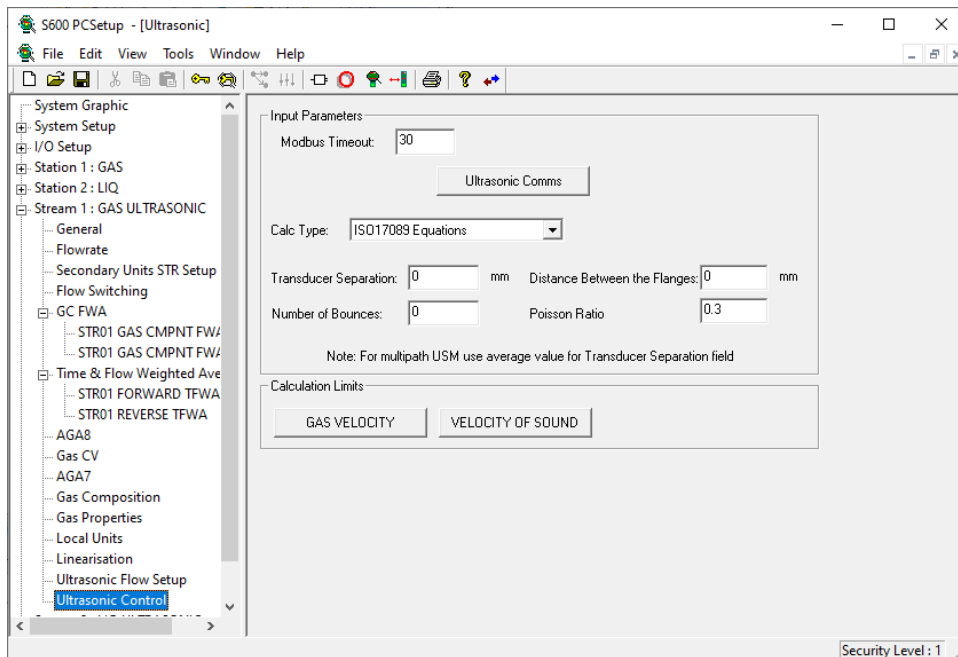

Figure 6-86. Ultrasonic Control screen

2. Complete the following fields.

Field	Description
<b>Modbus</b>	Sets, in seconds, the amount of time the system waits

Field	Description
<b>Timeout</b>	before triggering a Modbus timeout. The default is <b>30</b> . <b>Note:</b> If a timeout occurs, the system sets the gas velocity to zero (0) and raises a timeout alarm.

- Click any of the following buttons to define input parameters and calculation limits for the ultrasonic flow.

Button	Description				
<b>Ultrasonic Comms</b>	Click to display the Comms screen in the I/O Setup screen, and focuses on the Daniel USonic link comm settings.				
<b>GAS VELOCITY</b>	Click to display a Calculation Result dialog box you use to define the mode, keypad value, and the specific alarm limits for gas velocity.				
<b>Calc Type</b>	Sets which calculations the system uses with ultrasonic meters. Click ▼ to display all valid calculations. <table border="1"> <tbody> <tr> <td><b>Daniel Equations</b></td> <td>Use Daniel equations for ultrasonic meter calculations.</td> </tr> <tr> <td><b>ISO17089 Equations</b></td> <td>Use ISO 17089-1 Annex E (correction of meter geometry for ultrasonic meter calculations).</td> </tr> </tbody> </table>	<b>Daniel Equations</b>	Use Daniel equations for ultrasonic meter calculations.	<b>ISO17089 Equations</b>	Use ISO 17089-1 Annex E (correction of meter geometry for ultrasonic meter calculations).
<b>Daniel Equations</b>	Use Daniel equations for ultrasonic meter calculations.				
<b>ISO17089 Equations</b>	Use ISO 17089-1 Annex E (correction of meter geometry for ultrasonic meter calculations).				
<b>Transducer Separation</b>	Enter the distance, in millimeters, between the first and second transducer. <b>Note:</b> <ul style="list-style-type: none"> <li>This field displays <b>only</b> in you select <b>ISO17089 Equations</b> in the Calc Type field.</li> <li>Enter the average of the transducer separations.</li> </ul>				
<b>Number of Bounces</b>	Enter the number of reflections in the path between transducers. Set to 0 (For Daniel USM) <b>Note:</b> This field displays <b>only</b> in you select <b>ISO17089 Equations</b> in the Calc Type field.				
<b>Distance Between the Flanges</b>	Enter the distance, in millimeters, between the inlet and outlet flanges of the meter body. <b>Note:</b> This field displays <b>only</b> in you select <b>ISO17089 Equations</b> in the Calc Type field.				
<b>Poisson Ratio</b>	Sets the Poisson's Ratio value of the pipe. The default is <b>0.3</b> . <b>Note:</b> This field displays <b>only</b> in you select <b>ISO17089 Equations</b> in the Calc Type field.				
<b>VELOCITY OF SOUND</b>	Displays a Calculation Result dialog box you use to define the mode, keypad value, and the specific alarm limits for the velocity of sound.				

- Click in the hierarchy menu when you finish defining settings. A confirmation dialog box displays.
- Click **Yes** to apply your changes. The PCSetup screen displays.

### 6.6.11 QSonic Interface

The QSonic Interface control settings define the input parameters and calculation limits for the interface to the QSonic ultrasonic meter.

These settings allow you to define alarms. The system activates these alarms when the calculated results for the gas velocity are not within specified limits.

1. Select **Qsonic Interface** from the hierarchy menu. The Qsonic Interface screen displays.

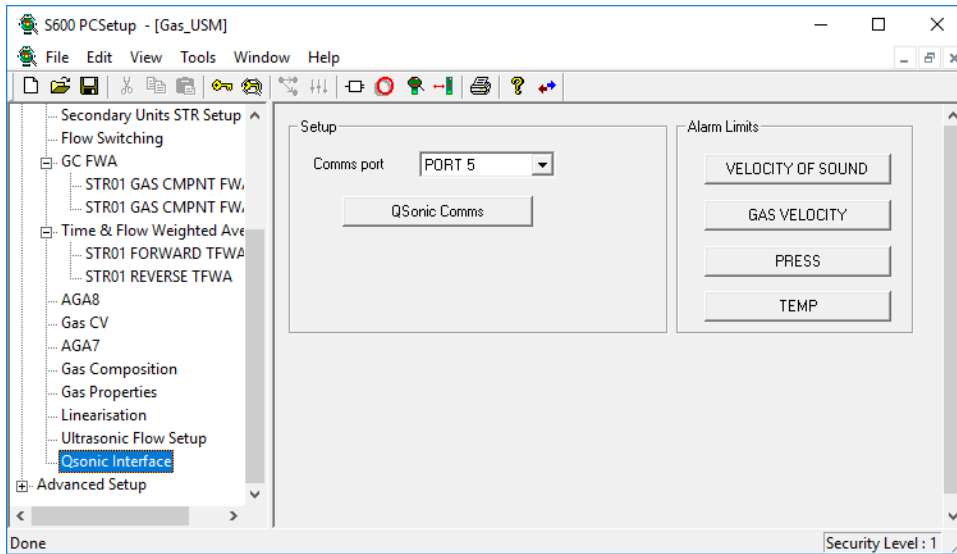

Figure 6-87. Qsonic Flow Setup screen

2. Complete the following fields to set up Qsonic values.

Button	Description
<b>Comms port</b>	Indicates the communication port to receive the Qsonic information. Click ▼ to display all valid values. The default is <b>PORT 5</b> .
<b>Qsonic Comms</b>	Displays the Comms Link screen, which you use to define the Qsonic Link (see <i>Chapter 4, Section 4.10</i> ).

3. Click any of the following buttons to define Qsonic alarm limits.

Field	Description
<b>VELOCITY OF SOUND</b>	Displays a Calculation Result dialog box you use to define the mode, keypad value, and specific alarm limits for the velocity of sound.
<b>GAS VELOCITY</b>	Displays a Calculation Result dialog box you use to define the mode, keypad value, and specific alarm limits for the gas velocity.
<b>PRESS</b>	Displays a Calculation Result dialog box you use to define the mode, keypad value, and specific alarm limits for pressure.
<b>TEMP</b>	Displays a Calculation Result dialog box you use to define the mode, keypad value, and specific alarm limits for temperature.

4. Click in the hierarchy menu when you finish defining settings. A confirmation dialog box displays.
5. Click **Yes** to apply your changes. The PCSetup screen displays.

## 6.6.12 SICK Control



The SICK Control settings define the primary inputs, calculations limits, and spool values for flowrate data received from the SICK ultrasonic meter.

These settings also allow you to define alarms. The system activates these alarms when the calculated results are not within specified limits.

1. Select **Sick Control** from the hierarchy menu. The Sick Control screen displays.

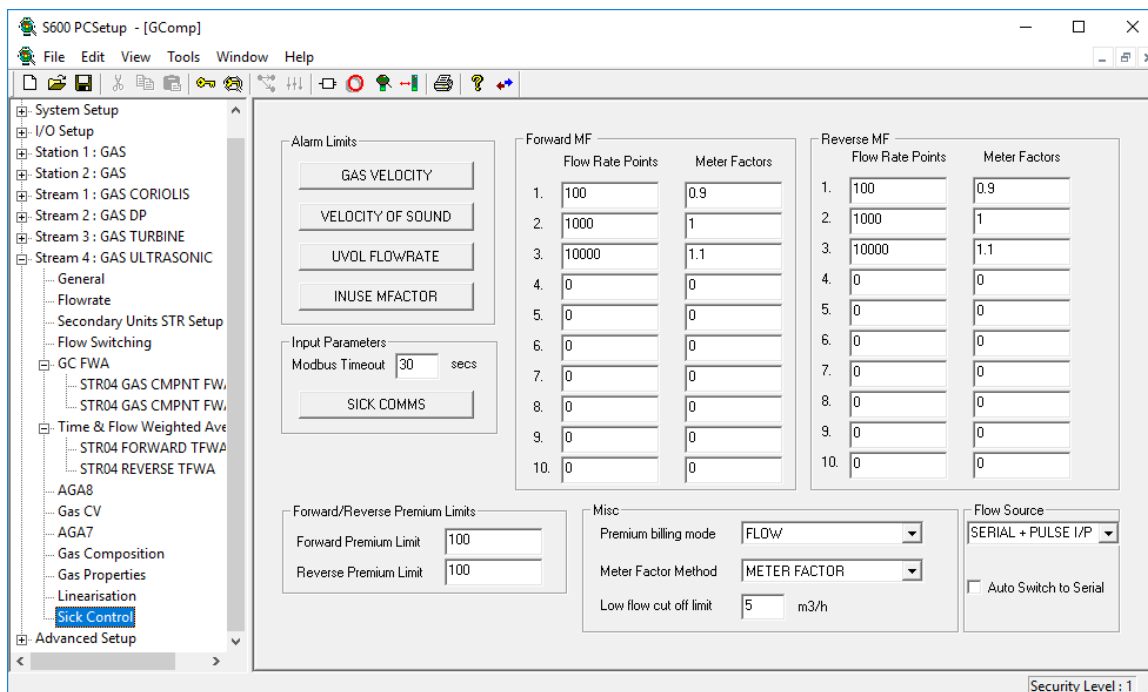

Figure 6-88. SICK Control screen

2. Click any of the following buttons to define alarm limits for the ultrasonic flow.

Button	Description
<b>GAS VELOCITY</b>	Click to display a Calculation Result dialog box you use to define the mode, keypad value, and the specific alarm limits for gas velocity.
<b>VELOCITY OF SOUND</b>	Click to display a Calculation Result dialog box you use to define the mode, keypad value, and the specific alarm limits for the velocity of sound.
<b>UVOL FLOWRATE</b>	Click to display a Calculation Result dialog box you use to define the specific alarm limits for uncorrected volume flowrate.
<b>INUSE MFACTOR</b>	Click to display a Calculation Result dialog box you use to define the mode, keypad value, and the specific alarm limits for the in-use Meter factor.

3. Complete the following fields.

Field	Description
<b>Modbus Timeout</b>	Sets, in seconds, the amount of time the S600+ waits before triggering a Modbus timeout. The default is 30.
<b>SICK COMMS</b>	Click to display the Comm screen in I/O Setup.

Field	Description
<b>Forward MF</b>	
<b>Flow Rate Points</b>	Sets up to 10 flow rate points for forward meter factor linearisation
<b>Meter Factors</b>	Sets up to 10 meter factor values for forward Meter Factor linearisation. <b>Note:</b> If the Meter Factor Method is <b>ERROR PERCENT</b> , enter the meter factors as percentages.
<b>Reverse MF</b>	
<b>Flow Rate Points</b>	Sets up to 10 flow rate points for reverse meter factor linearisation.
<b>Meter Factors</b>	Sets up to 10 meter factor values for reverse meter factor linearisation. <b>Note:</b> If the Meter Factor Method is <b>ERROR PERCENT</b> , enter the meter factors as percentages.
<b>Forward Premium Limit</b>	In Premium Billing FLOW mode and Flow Direction FORWARD. sets a flowrate limit above which the system increments forward premium totals whenever the flowrate exceeds the keypad limit. In Premium Billing TOTAL mode and Flow Direction FORWARD, sets a total limit above which the system increments forward premium totals whenever the period total exceeds the keypad limit. The default is <b>100</b> .
<b>Reverse Premium Limit</b>	In Premium Billing FLOW mode and Flow Direction REVERSE, sets a flowrate limit above which the system increments reverse premium totals whenever the flowrate exceeds the keypad limit. In Premium Billing TOTAL mode and Flow Direction REVERSE, sets a total limit above which the system increments reverse premium totals whenever the period total exceeds the keypad limit. The default is <b>100</b> .
<b>Premium Billing Mode</b>	Indicates the premium total mode, in which the system increments premium totals at the end of the hour only if the hourly total exceeds the keypad limit. Click ▼ to display all valid values. <b>FLOW</b> In Premium Billing Flow mode, the system increments premium totals whenever the flowrate exceeds the keypad limit. This is the <b>default</b> . <b>TOTAL</b> In Premium Billing Total mode, the system increments premium totals whenever the period total exceeds the keypad limit.
<b>Meter Factor Method</b>	Indicates the method used to calculate meter factor. Click ▼ to display all valid values. <b>METER FACTOR</b> Interpolate between the two nearest meter factors in the linearisation table. This is the <b>default</b> . <b>ERROR PERCENT</b> Interpolate between the two nearest percentage error

Field	Description
	values in the linearisation table
<b>Limit Flow Cut Off Limit</b>	Sets a low flow value at which point the meter sets the output flowrate to zero.
<b>Flow Source</b>	Indicates the source for generating flow totals.
	<b>SERIAL</b> Use the serial communications link. This is the <b>default</b> .
	<b>PULSE I/P</b> Use the pulse input.
	<b>SERIAL + PULSE I/P</b> Use the serial communications link as default and switch to the pulse input if a fault is detected. <b>Note:</b> This option requires both a serial interface and pulse input to be configured.
<b>Auto Switch to Serial</b>	If selected, the S600+ will revert to using serial communications once available. <b>Note:</b> This option is available <b>only</b> if you select SERIAL + PULSE I/P in the Flow Source.

4. Click in the hierarchy menu when you finish defining settings. A confirmation dialog box displays.
5. Click **Yes** to apply your changes. The PCSetup screen displays.

## 6.7 Liquid – Coriolis

These stream settings are specific to liquid applications using a Coriolis meter. When you initially create a configuration, the calculation selections you make determine which calculation-specific screens appear in the hierarchy menu.



### Caution

**It is extremely unlikely that any one S600+ configuration would contain all the settings discussed in this section. For that reason, several sample configurations demonstrate the settings.**

### 6.7.1 Local Units

This option allows you to override the global K-factor unit, since a liquid application may have more than one type of meter, each using different K-factor units.

1. Select **Local Units** from the hierarchy menu. The Local Units screen displays.

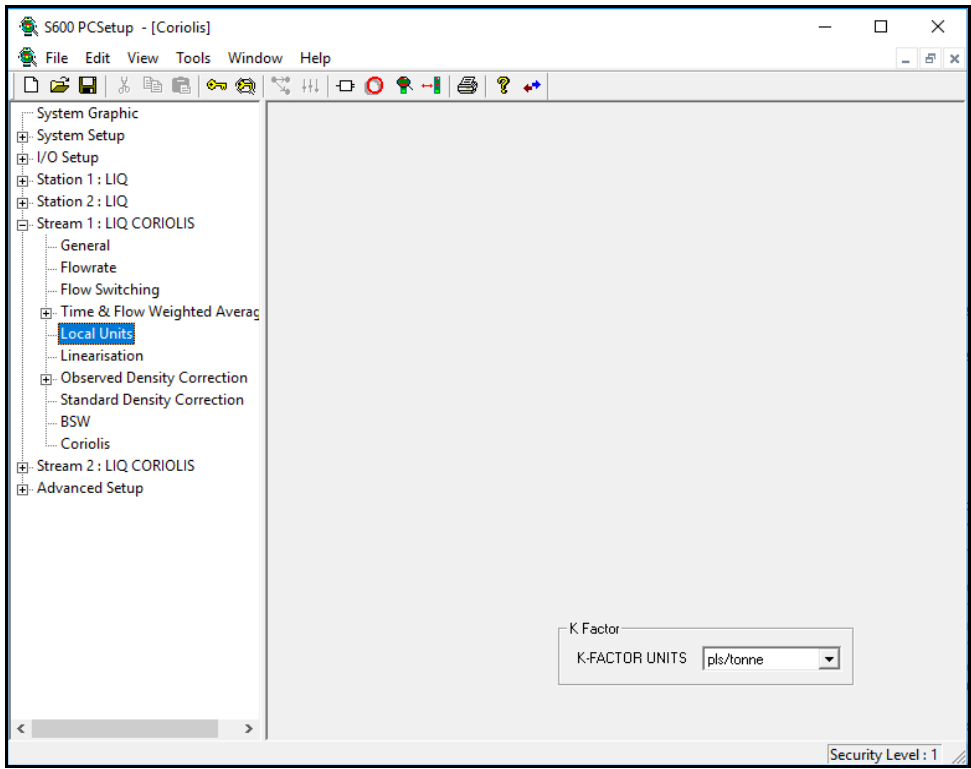

Figure 6-89. Local Units screen

2. Complete the following field.

Field	Description
<b>K-Factor Units</b>	Indicates the type of units to use and override the system K-factor units of measurement. Click ▼ to display all valid values. The default is <b>SYSTEM UNITS</b> . <b>Note:</b> If you select <b>System Units</b> , the stream uses the global default value.

3. Click in the hierarchy menu when you finish defining settings. A confirmation dialog box displays.
4. Click **Yes** to apply your changes. The PCSetup screen displays.

### 6.7.2 Linearisation

Linearisation settings define the constants and calculation limits for the meter factor and K factor. The S600+ calculates a meter factor corresponding to the frequency by interpolating the frequency between fixed points and then cross-referencing the result against a lookup table. Linearisation settings also allow you to define alarms. The system activates these alarms when the calculated results for the Meter Factor is not within specified limits.

**Notes:**

- The linearisation curve for Liquid Coriolis configurations uses Mass Flow Rate as the default input for Meter Factor calculations. The ability to change the default is available **only** with Config600 Pro software.

- Batching systems that employ meter factor linearisation with retrospective meter factor adjustments assume that the adjusted value has a “keypad” mode.
- To prevent the live metering system from applying a double correction, use **either** a calculated meter factor **or** a calculated K-factor linearisation (that is, only one factor should have a calculated mode).

1. Select **Linearisation** from the hierarchy menu. The Linearisation screen displays.

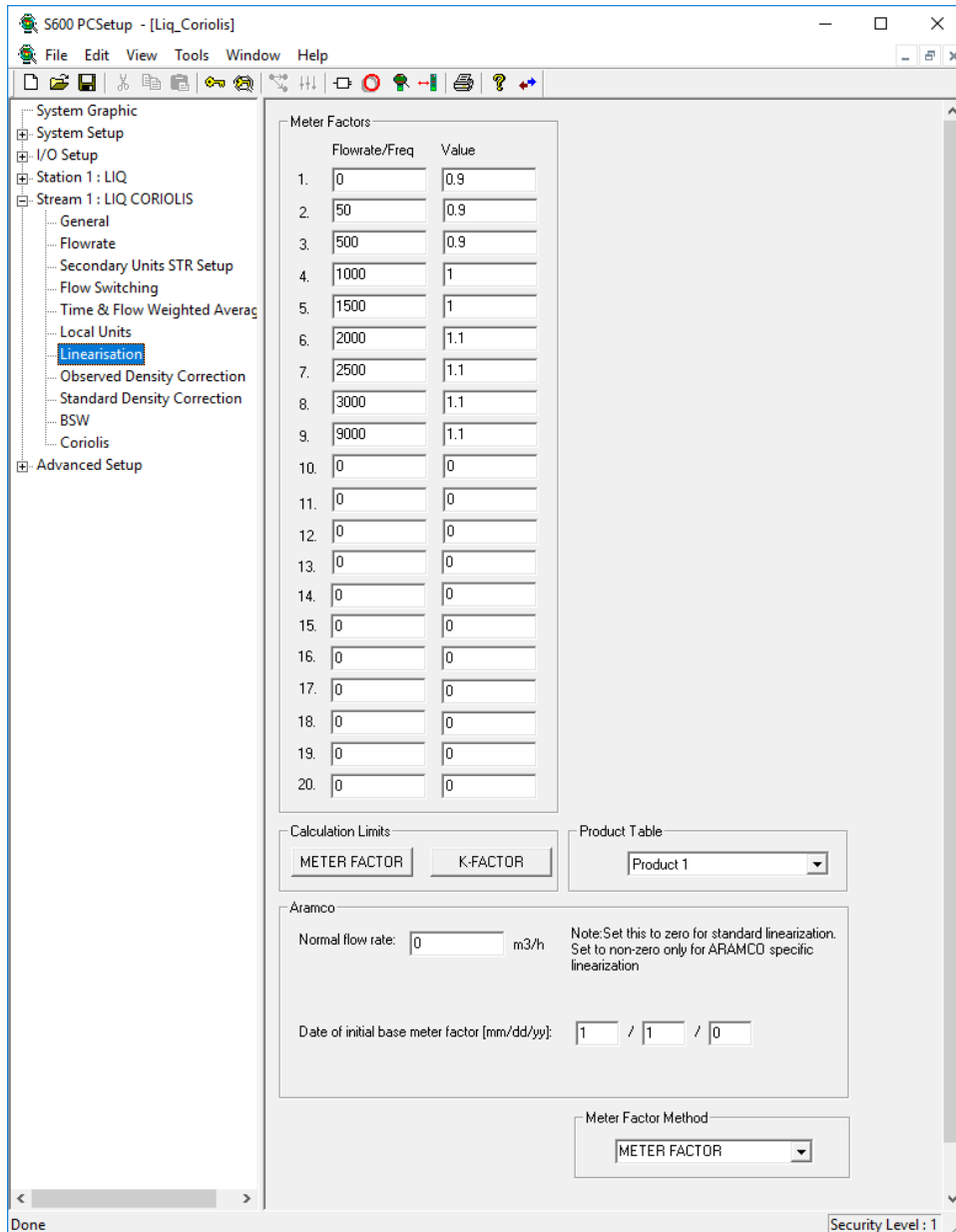

Figure 6-90. Linearisation screen

2. Complete the following fields.

<b>Field</b>	<b>Description</b>
<b>Meter Factors</b>	Sets up to 20 flow rate and values for the meter correction factors.
	<b>Flowrate/Freq</b> Set the flowrate and frequency for each of the meter correction factors.
	<b>Value</b> Set the corresponding values for each of the meter factors.
<b>METER FACTOR</b>	Click to display a Calculation Result dialog box you use to define the mode, keypad value, and the specific alarm limits for the respective factor.
<b>K- FACTOR</b>	Click to display a Calculation Result dialog box you use to define the mode, keypad value, and the specific alarm limits for the respective factor.
<b>Product Table</b>	It allows the selection of the “default” Product Table (the in-use functionality) and the 16 other Product Tables in order to set up to 10 flow rates and values for the meter correction factors and K-factors for each product type. When you select a specific product, the meter factors and K-factors update accordingly. <b>Note:</b> This field displays <b>only</b> if you enable the Product Table when you create the configuration.
<b>Aramco</b>	Aramco-style linearisation is identical to normal linearisation, but is only used to generate the first meter factor – subsequent meter factors are generated from proving. <b>Notes:</b> <ul style="list-style-type: none"> <li>▪ Ignore the fields in the Aramco frame unless directed by technical support.</li> <li>▪ You <b>must</b> select Product Table with History when you create your configuration in order to use the Prover MF Deviation Check stage.</li> </ul>
	<b>Normal Flow Rate</b> Set to zero for standard linearisation. Set to non-zero <b>only</b> for Aramco-style linearisation. <b>Note:</b> For Aramco-style linearisation <b>only</b> , the Initial Meter Factor is calculated from the linearisation curve and the Normal Flow Rate. This Initial Meter Factor is then used in the subsequent proving functionality.
	<b>Date of Initial Base Meter Factor</b> Set the time stamp of the initial base meter factor. <b>Note:</b> This field displays <b>only</b> if you enable the Product Table with History when you create the configuration.
<b>Meter Factor Method</b>	Selectable between METER FACTOR (values entered as normal) and ERROR PERCENT (Meter Factor entered as a percentage).

3. Click in the hierarchy menu when you finish defining settings. A confirmation dialog box displays.

4. Click **Yes** to apply your changes. The PCSetup screen displays.

### 6.7.3 Sampling

Sampling settings define the method and interval period for sampling product from a flowing pipeline. By default, the S600+ supports one sampler per stream. If you require more than one sampler per stream, contact Technical Support personnel. Config600 uses the following stages during the sampling process:

Stage	Description
0	Idle
1	Monitor
2	Digout n
3	Min Intvl
4	Post Pulse
5	Stopped Manually
6	Stopped Can Full
7	Stopped Low Flow
8	Initial Time
9	Check Flow Switch
10	Stopped Flow Switch
11	Stopped Press Switch
12	Stopped initialise
13	Can Switch Over

**Note:** Batch auto-resets the sampler at the start of the batch.

1. Select **Sampling** from the hierarchy menu. The Sampling screen displays.

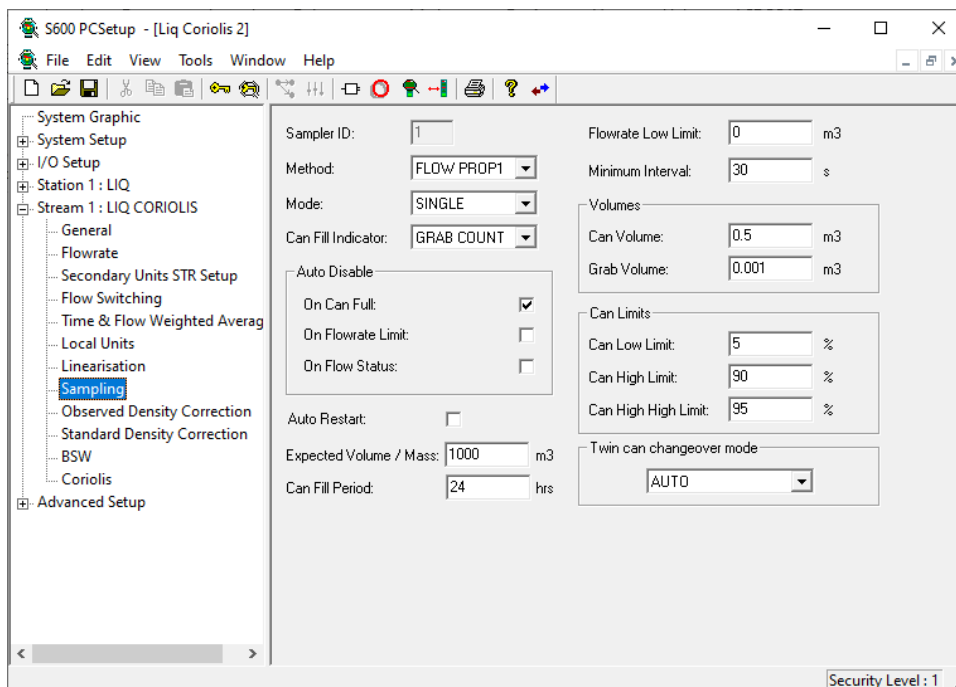

Figure 6-91. Sampling screen

2. Complete the following fields.

Field	Description
Sampler ID	Provides an identifying label for the sampler. Each

Field	Description
	stream or station must have a unique sampler ID.
<b>Method</b>	Indicates the sampling method. Click ▼ to display all valid values.
	<b>TIME PROP</b> Divides the value in the Can Fill Period field by the number of grabs needed to fill the can (derived from the Can Volume and Fill Volume values) to determine a time interval per pulse. This is the <b>default</b> .
	<b>FLOW PROP1</b> Divides the value in the Volume field by the number of grabs needed to fill the can (derived from the Can Volume and Fill Volume values) to determine a volume throughput per pulse.
	<b>FLOW PROP2</b> Uses the value in the Volume field as the volume throughput per pulse.
	<b>FLOW PROP3</b> Uses the value in the Volume field as the volume throughput per pulse, but supports low pressure digital input and pump prime output.
<b>Mode</b>	Indicates the sampling mode. Click ▼ to display all valid values. The default is <b>SINGLE</b> .
<b>Can Fill Indicator</b>	Indicates how the S600+ determines when the sampling can is full. Click ▼ to display all valid values. The default is <b>GRAB COUNT</b> .
	<b>GRAB COUNT</b> Uses the number of pulses output during the sample to determine when the can is full.
	<b>DIG I/P</b> Uses a digital input to determine when the can is full.
	<b>ANALOG I/P</b> Uses an analog input to determine when the can is full.
<b>Auto Disable</b>	Indicates the event at which the system automatically disables the sampling process. Select the appropriate check box to identify the specific event.
<b>Auto Restart</b>	Indicates whether the system automatically restarts sampling after automatically disabling sampling.
<b>Expected Volume/Mass</b>	Sets the volume or mass of the sampling can. The default is <b>1000</b> .
<b>Can Fill Period</b>	Sets, in hours, the time required to fill the sampling can. The default is <b>24</b> .
	<b>Note:</b> This field is required for the TIME PROP sampling method.
<b>Flowrate Low Limit</b>	Sets the volume at which automatic disabling occurs. The default is <b>0</b> .
	<b>Note:</b> This field is required if you select the On Flowrate Limit check box for Auto Disable.
<b>Minimum Interval</b>	Sets the minimum interval, in seconds, for sampling. The default is <b>30</b> .
	<b>Note:</b> If the sample exceeds this limit, the system sets the overspeed alarm and increments the overspeed counter.
<b>Can Volume</b>	Sets the volume of the sampling can. The default is <b>0.5</b> .



Field	Description			
<b>Grab Volume</b>	Sets the volume of each sampling grab. The default is <b>0.001</b> .			
<b>Can Low Limit</b>	Sets the low limit alarm as a percentage of the Can Volume. The default is <b>5</b> .			
<b>Can High Limit</b>	Sets the high limit alarm as a percentage of the Can Volume. The default is <b>90</b> .			
<b>Can High High Limit</b>	Sets the high high alarm as a percentage of the Can Volume. The default is <b>95</b> .			
<b>Twin Can Changeover Mode</b>	Indicates the changeover method for twin can sampling. Click ▼ to display all valid values.			
	<table border="1"> <tbody> <tr> <td><b>AUTO</b></td> <td>The sampler automatically changes over to the second can when the first is full.</td> </tr> <tr> <td><b>MANUAL</b></td> <td>The sampler pauses sampling when the first can is full and requires the operator to change the value of Can Selected before sampling continues on the second can.</td> </tr> </tbody> </table> <p><b>Note:</b></p> <ul style="list-style-type: none"> <li>▪ If sampling is stopped because both cans are full, the Twin Can Changeover Mode is set to MANUAL by the system. The user must set back to AUTO if required.</li> <li>▪ The display for Twin Can Changeover must be manually added to the displays.</li> </ul>	<b>AUTO</b>	The sampler automatically changes over to the second can when the first is full.	<b>MANUAL</b>
<b>AUTO</b>	The sampler automatically changes over to the second can when the first is full.			
<b>MANUAL</b>	The sampler pauses sampling when the first can is full and requires the operator to change the value of Can Selected before sampling continues on the second can.			

3. Click in the hierarchy menu when you finish defining settings. A confirmation dialog box displays.
4. Click **Yes** to apply your changes. The PCSetup screen displays.

#### 6.7.4 Observed Density Correction

This option enables you to determine base density from measured density. You can include density measurement from a densitometer or from the Coriolis meter, as your needs demand.

You configure the Observed Density Correction according to the densitometer location options you select at the station and stream when you initially build the configuration. If you select the **Use Standard Density** stream option then the observed density screen does not display.

A Coriolis meter can measure density and so you may read density from the Coriolis or density from a densitometer. SEL TO BASE is only available for Coriolis applications.

The system uses base density, coordinated with the standard density correction, to calculate correction values for the temperature of the liquid at the meter ( $CTL_m$ ) and the pressure of the liquid at the meter ( $CPL_m$ ). The system then uses the  $CTL_m$  and  $CPL_m$  values to correct the metered volume to reference conditions.

**Note:** Depending on the configuration, you may need to define **both** densitometer values (**DT TO BASE**) and selected meter densities (**SEL TO BASE**) options. Although the following screen examples **do not** show these options, descriptions of these options (which occur in the Calculation Results and Live Inputs buttons) **are** included in the field descriptions.

1. Select **Observed Density Correction** from the hierarchy menu.
2. Select the appropriate component of Observed Density Correction (DT TO BASE or SEL TO BASE) from the hierarchy menu, if necessary. The Observed Density Correction screen displays.

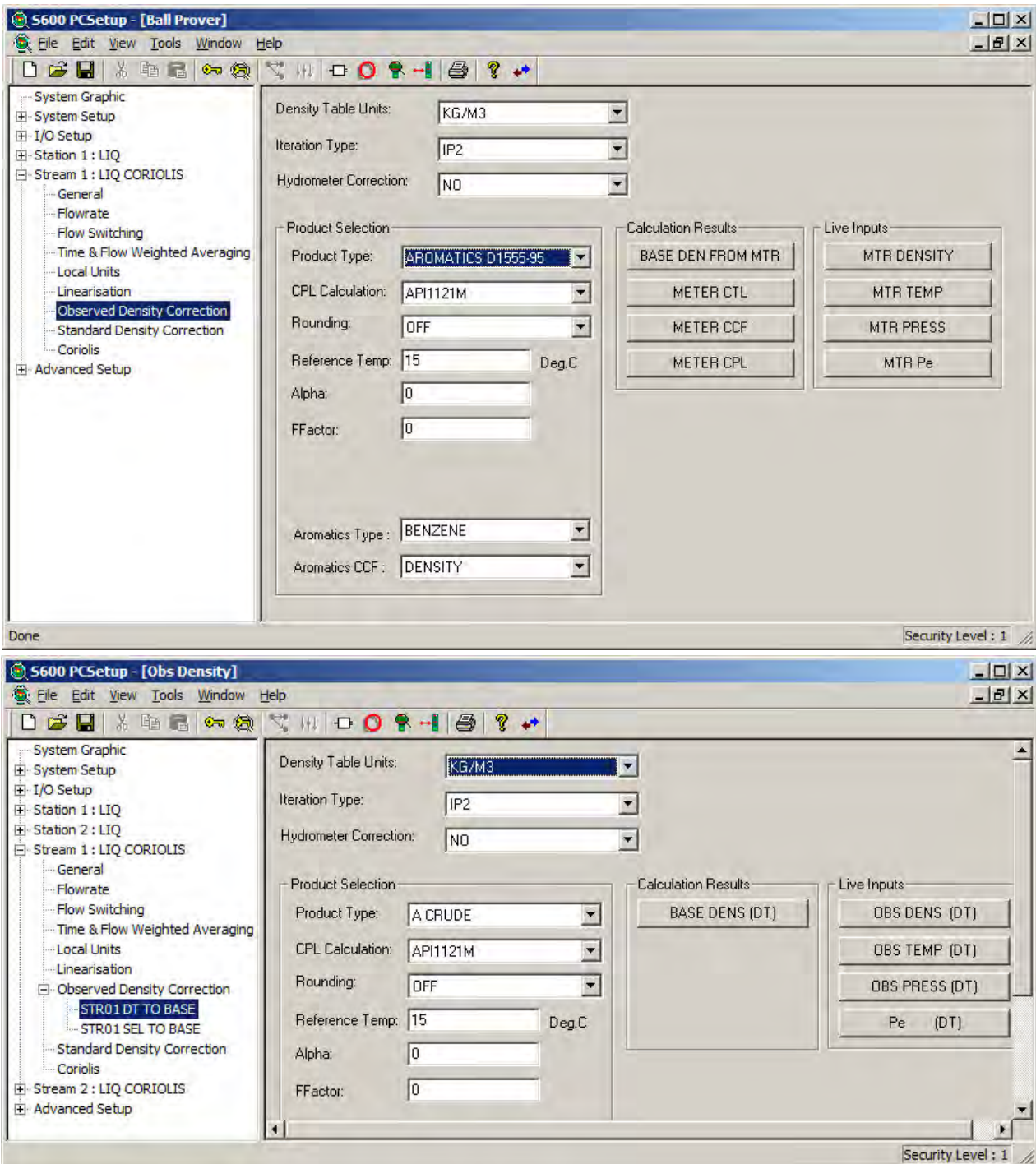

Figure 6-92. Observed Density Correction screens

3. Complete the following fields.

Field	Description
<b>Density Table Units</b>	Indicates the density units the S600+ uses for the density correction calculations. Click ▼ to display all valid values.
	<b>CH. 11 2004/7 CUST</b> Use API MPMS Chapter 11.1 2004, Addendum 1, 2007 Imperial Units.
	<b>CH. 11 2004/7 METRIC</b> Use API MPMS Chapter 11.1 2004, Addendum 1, 2007 Metric Units.
	<b>DEG API</b> Use degrees API.
	<b>KG/M3</b> Use kilograms per cubic meter. This is the <b>default</b> .
	<b>S.G.</b> Use specific gravity.
	<b>KG/M3</b> Use kilograms per cubic meter. This is the <b>default</b> .
	<b>NORSOK I-105</b> Use Norsok I-105 Appendix D density correction.
<b>Iteration Type</b>	Indicates the iteration type for the density correction calculations. Valid values are <b>ASTM</b> (use the iterative temperature and pressure correction as defined by ASTM/API, Chapter 12) or <b>IP2</b> (use the iterative temperature and pressure correction as defined in IP 2 [ISO 91-1]). The <b>default</b> is <b>ASTM</b> .
<b>Hydrometer Correction</b>	Indicates whether the S600+ applies hydrometer correction values to the calculation. Valid values are <b>YES</b> and <b>NO</b> ; the default is <b>NO</b> .
<b>Product Type</b>	Indicates the type of petroleum product involved in the calculation. Click ▼ to display all valid values. The <b>default</b> is <b>A CRUDE</b> .
	<p><b>A CRUDE</b> Selection is based on the value in the Density Table Units field:            If Density Table Units = KG/M3 and reference temperature = 15 Deg C, Petroleum Measurement Tables 1980 Tables 53A and 54A.            If Density Table Units = KG/M3 and reference temperature = 20 Deg C, Petroleum Measurement Tables 1988 Tables 59A and 60A.            If SG = Petroleum Measurement Tables 1980 Tables 23A and 24A.            If DEG API = Petroleum Measurement Tables 1980 Tables 5A and 6A.            If CH.11 2004/7, Cust = API MPMS Chapter 11 2004.            If CH.11 2004/7, Metric = API MPMS Chapter 11 2004.</p> <p><b>B REFINED</b> Selection is based on the value in the Density Table Units field:            If Density Table Units = KG/M3 and reference temperature = 15 Deg C, Petroleum Measurement Tables 1980 Tables 53B and 54B.            If Density Table Units = KG/M3 and reference temperature = 20 Deg C, Petroleum Measurement Tables</p>

Field	Description
	<p>1988 Tables 59B and 60B.                      If SG = Petroleum Measurement Tables 1980 Tables 23B and 24B.                      If DEG API = Petroleum Measurement Tables 1980 Tables 5B and 6B.                      If CH.11 2004/7 = API MPMS Chapter 11 2004.                      If CH.11 2004/7, Metric = API MPMS Chapter 11 2004.</p>
<b>C SPECIAL</b>	<p>Selection is based on the value in the Density Table Units field:                      If KG/M3 =, Petroleum Measurement Tables 1980 Table 54C.                      If SG =, Petroleum Measurement Tables 1980 Tables 23C and 24C.                      If DEG API = Petroleum Measurement Tables 1980 Tables 5C and 6C.                      If CH.11 2004/7, Cust = API MPMS Chapter 11 2004.                      If CH.11 2004/7, Metric = API MPMS Chapter 11 2004.  <b>Note:</b> Table 53C is not implemented as the assumption is made that the base density is already known. This is because Table 53C allows for a keypad entry of Alpha, and if this is known then the base density would be known.</p>
<b>D LUBE OILS</b>	<p>Selection is based on the value in the Density Table Units field:                      If Density Table Units = KG/M3 and reference temperature = 15 Deg C, Petroleum Measurement Tables 1982 Tables 53D and 54D.                      If Density Table Units = KG/M3 and reference temperature = 20 Deg C, Petroleum Measurement Tables 1988 Tables 59D and 60D.                      If SG = Petroleum Measurement Tables 1982 Tables 23D and 24D.                      If DEG API = Petroleum Measurement Tables 1982 Tables 5D and 6D.                      If CH.11 2004/7, Cust API = MPMS Chapter 11 2004.                      If CH.11 2004/7 = API MPMS Chapter 11 2004.</p>
<b>LIGHT 1986</b>	<p>ASTM-IP-API Petroleum Measurement Tables for Light Hydrocarbon Liquids 1986 Tables 53 and 54.</p>
<b>ASTM-IP 1952</b>	<p>ASTM-IP Petroleum Measurement Tables 1952 Tables 23, 24, 53 and 54.</p>

Field	Description
	<b>Note:</b> The output is based on the relevant formula or look up tables dependent on the density input.
<b>TABLE LOOKUP</b>	S600+ reads values from a file in the Config600 3.0/Config/Project Name/extras directory and transfers that data into the S600+ with the configuration file. The default files hold values for the ASTM-IP Petroleum Measurement Tables 1952 Tables 5 and 6.
<b>USER K0K1</b>	Selection is based on the value in the Density Table Units field: If KG/ = Petroleum Measurement Tables 1980 Tables 53A and 54A with user entered values for K0 and K1. If SG = Petroleum Measurement Tables 1980 Tables 23A and 24A with user entered values for K0 and K1. If DEG API = Petroleum Measurement Tables 1980 Tables 5A and 6A with user entered values for K0 and K1.
<b>LIGHT TP25</b>	GPA TP-25 1998 (API Tables 23E and 24E).
<b>LIGHT TP27</b>	GPA TP-27 2007 (API Tables 23E, 24E, 53E, 54E, 59E and 60E).
<b>AROMATICS D1555M-95</b>	ASTM D1555-95 Table lookup.
<b>AROMATICS D1555M-00</b>	ASTM D1555M-00 Table Lookup.
<b>AROMATICS D1555M-04A</b>	ASTM D1555-04a Calculation.
<b>AROMATICS D1555M-08</b>	ASTM D1555M-08 Calculation.
<b>STO5.9 08 B1 UGC</b>	Gazprom STO-5.9 2008 Addendum B.1 Unstable Gas Condensate.
<b>STO5.9 08 B2 SLH</b>	Gazprom STO-5.9 2008 Addendum B.2 Stable Liquid Hydrocarbon.
<b>STO5.9 08 B3 WFLH</b>	Gazprom STO-5.9 2008 Addendum B.3 Wide Fraction Liquid Hydrocarbon.
<b>CPL Calculation</b>	Indicates the specific CPL calculation the S600+ uses. Click ▼ to display all valid values. <b>Note:</b> This field <b>does not</b> display if you select <b>CH.11 2004 CUST</b> or <b>CH.11 2004 METRIC</b> as the Density Table Units or one of the Gazprom options as Product Type because these standards also specify the CPL calculation.
<b>OFF</b>	No CPL calculation.
<b>API1121</b>	Use API MPMS Ch.11.2.1 1984.
<b>API1121M</b>	Use API MPMS Ch. 11.2.1M 1984. This is the <b>default</b> .
<b>API1122</b>	Use API MPMS Ch.11.2.2 1986
<b>API1122M</b>	Use API MPMS Ch.11.2.2M 1986

Field	Description
	<b>CONSTANT</b> Use a value you enter.
	<b>DOWNER</b> Use calculations specified in L. Downer's 1979 paper <i>Generation of New Compressibility Tables for International Use</i>
<b>Rounding</b>	Indicates whether the S600+ rounds the calculation results. Click ▼ to display all valid values.
	<b>OFF</b> No rounding occurs. This is the <b>default</b> .
	<b>NATIVE</b> Round to the rules specified in the selected calculation standard.
	<b>API Ch.12.2 Part 2</b> Round in accordance with API MPMS Ch. 12.2 Part 2 – Measurement Tickets 1995
	<b>API Ch.12.2 Part 3</b> Round in accordance with API MPMS Ch. 12.2 Part 3 – Proving Reports 1998
	<b>Flocheck</b> Round in accordance with Emerson Flowcheck verification software package
	<b>ASTM D1250-04 Ch.11</b> Round in accordance with API MPMS Ch. 11.1 2004 (ASTM D1250-04) method to round to the Petroleum Measurement Table 1980 Tables
	<b>DECC 1980</b> DTI/DECC requirements for Petroleum Measurement Tables 1980 Tables. No rounding occurs and an iteration tolerance of 0.0001.
<b>Reference Temp</b>	Indicates, in degrees Centigrade, the reference temperature for the correction calculations. The default is <b>15</b> degrees C.
<b>Alpha</b>	Sets the coefficient of thermal expansion. The default is <b>0</b> .
<b>FFactor</b>	Sets the compressibility factor for the liquid (also known as the beta factor). The default is <b>0</b> .
<b>PE Calculation</b>	Sets the option to calculate the fluid's Equilibrium Vapour Pressure. While this is normally assumed to be 0, you can use it for natural gas liquids (NGL) and similar applications. Click ▼ to display all valid values.
	<b>OFF</b> Do not calculate PE value. This is the <b>default</b> .
	<b>GPA TP-15 1988 Equation 2</b> Use the GPA TP-15 1988 Equation 2
	<b>GPA TP-15 2003 Equation 2</b> Use the GPA TP-15 2003 Equation 2
	<b>GPA TP-15 1988 Equation 3</b> Use the GPA TP-15 1988 Equation 3
	<b>GPA TP-15 2003 Equation 3</b> Use the GPA TP-15 2003 Equation 3
<b>Aromatics Type</b>	Sets the type of aromatics product. Click ▼ to display all valid values. The default is <b>Benzene</b> .
<b>Aromatics CCF</b>	Sets the method for calculating a combined corrector factory (CCF) for aromatics products. Valid values are <b>Density</b> (calculate using a density you enter) or <b>Table 1</b> (calculate use a density from an embedded table).

Table 6-1. Observed Density Correction Product Selection

Density Units	Product Type									
	ASTM/IP 1952	A Crude	B Refined	C Special	D Lube Oils	Light 1986	Light TP25	Light TP27	Table Lookup	User K0 K1
DEG API	ASTM D1250 (1952) Table 5	ASTM D1250-80 Table 5A	ASTM D1250-80 Table 5B	n/a	ASTM D1250-80 Table 5D	n/a	n/a	n/a	User lookup table	ASTM D1250-80 Table 5A/ User K0,K1
S.G.	ASTM D1250 (1952) Table 23	ASTM D1250-80 Table 23A	ASTM D1250-80 Table 23B	n/a	ASTM D1250-80 Table 23D	n/a	GPA TP-25/ 1988 Table 23E	GPA TP-27 Table 23E	User lookup table	ASTM D1250-80 Table 23A/ User K0,K1
KG/M3	ASTM D1250 (1952) Table 53	ASTM D1250-80 Table 53A IP Paper 3 (1988) Table 59A (20°C Reference Temp)	ASTM D1250-80 Table 53B IP Paper 3 (1988) Table 59B (20°C Reference Temp)	n/a	ASTM D1250-80 Table 53D IP Paper 3 (1988) Table 59D (20°C Reference Temp)	ASTM-IP-API Petroleum Measurement tables for light hydrocarbon liquids 1986	n/a	GPA TP-27 Table 53E GPA TP-27 Table 59E (20°C Reference Temp)	User lookup table	ASTM D1250-80 Table 53A/ User K0,K1
CH. 11 2004/7 CUST	n/a	ASTM D1250-04	ASTM D1250-04	ASTM D1250-04	ASTM D1250-04	n/a	n/a	n/a	n/a	n/a
CH. 11 2004/7 METRIC	n/a	ASTM D1250-04	ASTM D1250-04	ASTM D1250-04	ASTM D1250-04	n/a	n/a	n/a	n/a	n/a
NORSOK I-105	ASTM D1250-04	ASTM D1250-04	ASTM D1250-04	ASTM D1250-04	ASTM D1250-04	ASTM D1250-04	ASTM D1250-04	ASTM D1250-04	ASTM D1250-04	ASTM D1250-04

4. Click any of the following buttons to define calculation results for the observed density correction calculations.

Button	Description
<b>BASE DEN FROM MTR</b>	Click to display a Calculation Result dialog box you use to define the mode, keypad value, and the specific alarm limits for base density. <b>Note:</b> The label on this button changes depending on the configuration.
<b>BASE DENSITY</b>	Click to display a Calculation Result dialog box you use to define the mode, keypad value, and the specific alarm limits for base density. <b>Note:</b> The label on this button changes depending on the configuration.
<b>BASE DENS (DT)</b>	Click to display a Calculation Result dialog box you use to define the mode, keypad value, and the specific alarm limits for base density. <b>Note:</b> This button displays <b>only</b> if you select the densitometer (DT TO BASE) stream component.
<b>BASE DENS (SEL)</b>	Click to display a Calculation Result dialog box you use to define the mode, keypad value, and the specific alarm limits for base density. <b>Note:</b> This button displays <b>only</b> if you select the meter (SEL TO BASE) stream component.
<b>METER CTL</b>	Click to display a Calculation Result dialog box you use to define the mode, keypad value, and the specific alarm limits for the correction of the temperature of the liquid at the meter (CTL <sub>m</sub> ). <b>Note:</b> The label on this button changes depending on the configuration.

Button	Description
<b>METER CTL (SEL)</b>	Click to display a Calculation Result dialog box you use to define the mode, keypad value, and the specific alarm limits for the correction of the temperature of the liquid at the meter (CTL <sub>m</sub> ). <b>Note:</b> This button displays <b>only</b> if you select the meter (SEL TO BASE) stream component.
<b>METER CCF</b>	Click to display a Calculation Result dialog box you use to define the mode, keypad value, and the specific alarm limits for the combined correction factor at the meter (CCF <sub>m</sub> ). <b>Note:</b> The label on this button changes depending on the configuration
<b>METER CCF (SEL)</b>	Click to display a Calculation Result dialog box you use to define the mode, keypad value, and the specific alarm limits for the combined correction factor at the meter (CCF <sub>m</sub> ). <b>Note:</b> This button displays <b>only</b> if you select the meter (SEL TO BASE) stream component.
<b>METER CPL</b>	Click to display a Calculation Result dialog box you use to define the mode, keypad value, and the specific alarm limits for the correction of the pressure of the liquid at the meter (CPL <sub>m</sub> ). <b>Note:</b> The label on this button changes depending on the configuration.
<b>METER CPL (SEL)</b>	Click to display a Calculation Result dialog box you use to define the mode, keypad value, and the specific alarm limits for the correction of the pressure of the liquid at the meter (CPL <sub>m</sub> ). <b>Note:</b> This button displays <b>only</b> if you select the meter (SEL TO BASE) stream component.

5. Click any of the following buttons to define **live inputs** for the observed density correction calculations:

Button	Description
<b>MTR DENSITY</b>	Click to display a Calculation Result dialog box you use to define the mode, keypad value, and the specific alarm limits for meter density. <b>Note:</b> The label on this button changes depending on the configuration.
<b>OBS DENS (DT)</b>	Click to display a Calculation Result dialog box you use to define the mode, keypad value, and the specific alarm limits for observed density. <b>Note:</b> This button displays <b>only</b> if you select the densitometer (DT TO BASE) stream component.
<b>MTR DENS (SEL)</b>	Click to display a Calculation Result dialog box you use to define the mode, keypad value, and the specific alarm limits for meter density. <b>Note:</b> This button displays <b>only</b> if you select the meter (SEL TO BASE) stream component.
<b>MTR TEMP</b>	Click to display a Calculation Result dialog box you use to define the mode, keypad value, and the specific alarm limits for meter temperature. <b>Note:</b> The label on this button changes depending on the configuration.



Button	Description
<b>OBS TEMP (DT)</b>	Click to display a Calculation Result dialog box you use to define the mode, keypad value, and the specific alarm limits for observed temperature. <b>Note:</b> This button displays <b>only</b> if you select the densitometer (DT TO BASE) stream component.
<b>MTR TEMP (SEL)</b>	Click to display a Calculation Result dialog box you use to define the mode, keypad value, and the specific alarm limits for meter temperature. <b>Note:</b> This button displays <b>only</b> if you select the meter (SEL TO BASE) stream component.
<b>MTR PRESS</b>	Click to display a Calculation Result dialog box you use to define the mode, keypad value, and the specific alarm limits for meter pressure. <b>Note:</b> The label on this button changes depending on the configuration.
<b>OBS PRESS (DT)</b>	Click to display a Calculation Result dialog box you use to define the mode, keypad value, and the specific alarm limits for observed pressure. <b>Note:</b> This button displays <b>only</b> if you select the densitometer (DT TO BASE) stream component.
<b>MTR PRESS (SEL)</b>	Click to display a Calculation Result dialog box you use to define the mode, keypad value, and the specific alarm limits for meter pressure. <b>Note:</b> This button displays <b>only</b> if you select the meter (SEL TO BASE) stream component.
<b>MTR Pe</b>	Click to display a Calculation Result dialog box you use to define the mode, keypad value, and the specific alarm limits for equilibrium vapour pressure (Pe). <b>Note:</b> The label on this button changes depending on the configuration.
<b>Pe</b>	Click to display a Calculation Result dialog box you use to define the mode, keypad value, and the specific alarm limits for observed equilibrium vapour pressure (Pe). <b>Note:</b> The label on this button changes depending on the configuration.
<b>Pe (DT)</b>	Click to display a Calculation Result dialog box you use to define the mode, keypad value, and the specific alarm limits for observed equilibrium vapour pressure (Pe). <b>Note:</b> This button displays <b>only</b> if you select the densitometer (DT TO BASE) stream component.

6. Click in the hierarchy menu when you finish defining settings. A confirmation dialog box displays.
7. Click **Yes** to apply your changes. The PCSetup screen displays.

### 6.7.5 Standard Density Correction

This calculation enables you to use base density to determine the factors for the correction for temperature of the liquid at the meter ( $CTL_m$ ) and the correction for the pressure of the liquid at the meter ( $CPL_m$ ). The system then uses the  $CTL_m$  and  $CPL_m$  values to correct the metered volume to reference conditions.

1. Select **Standard Density Correction** from the hierarchy menu. The Standard Density Correction screen displays.

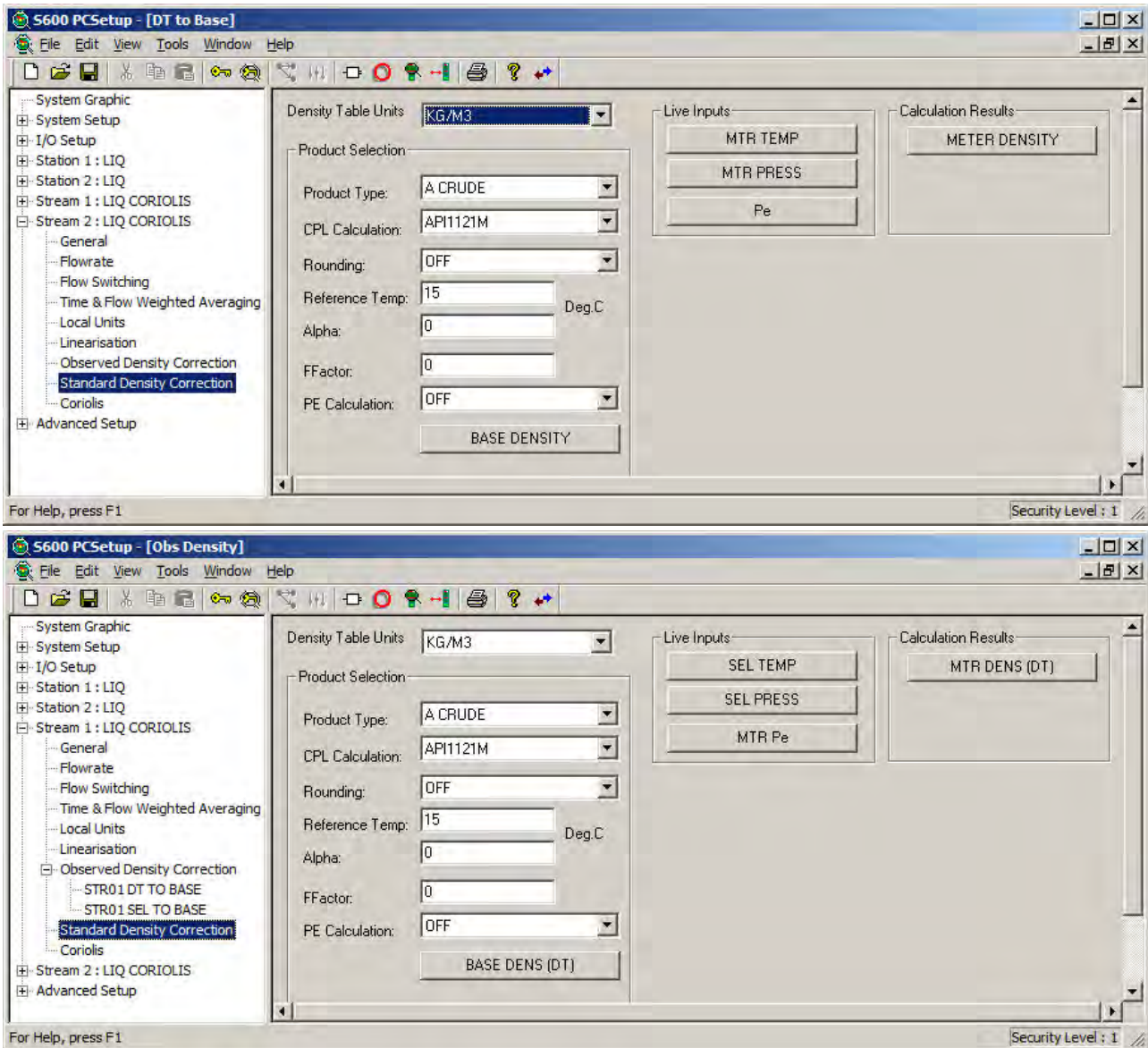

Figure 6-93. Standard Density Correction screens

2. Complete the following fields.

Field	Description
<b>Density Table Units</b>	Indicates the density units the S600+ uses for the density correction calculations. Click ▼ to display all valid values.
<b>CH. 11 2004/7 CUST</b>	Use API MPMS Ch. 11.1 2004, Addendum 1, 2007 Imperial units.

Field	Description
<b>CH. 11 2004/7</b>	Use API MPMS Ch. 11.1 2004, Addendum 1, 2007 Metric Units
<b>METRIC</b>	
<b>DEG.API</b>	Use degrees API.
<b>KG/M3</b>	Use kilograms per cubic meter. This is the <b>default</b> .
<b>S.G.</b>	Use specific gravity.
<b>NORSOK I-105</b>	Use Norsok I-105 Appendix D density correction.
	<b>Note:</b> See <i>Table 6-2</i> for product selection.
Product Type	Indicates the type of petroleum product involved in the calculation. Click ▼ to display all valid values. The <b>default</b> is <b>ACRUDE</b> .
<b>A CRUDE</b>	<p>Selection is based on the value in the Density Table Units field:</p> <p>If Density Table Units = KG/M3 and reference temperature = 15 Deg C, Petroleum Measurement Tables 1980 Tables 53A and 54A.</p> <p>If Density Table Units = KG/M3 and reference temperature = 20 Deg C, Petroleum Measurement Tables 1988 Tables 59A and 60A.</p> <p>If SG = Petroleum Measurement Tables 1980 Tables 23A and 24A.</p> <p>If DEG API = Petroleum Measurement Tables 1980 Tables 5A and 6A.</p> <p>If CH.11 2004/7, Cust = API MPMS Chapter 11 2004.</p> <p>If CH.11 2004/7, Metric = API MPMS Chapter 11 2004.</p>
<b>B REFINED</b>	<p>Selection is based on the value in the Density Table Units field:</p> <p>If Density Table Units = KG/M3 and reference temperature = 15 Deg C, Petroleum Measurement Tables 1980 Tables 53B and 54B.</p> <p>If Density Table Units = KG/M3 and reference temperature = 20 Deg C, Petroleum Measurement Tables 1988 Tables 59B and 60B.</p> <p>If SG = Petroleum Measurement Tables 1980 Tables 23B and 24B.</p> <p>If DEG API = Petroleum Measurement Tables 1980 Tables 5B and 6B.</p> <p>If CH.11 2004/7, Cust = API MPMS Chapter 11 2004.</p> <p>If CH.11 2004/7, Metric = API MPMS Chapter 11 2004.</p>

Field	Description
<b>C SPECIAL</b>	<p>Selection is based on the value in the Density Table Units field:</p> <p>If KG/M3 = Petroleum Measurement Tables 1980 Table 54C.</p> <p>If SG = Petroleum Measurement Tables 1980 Tables 23C and 24C.</p> <p>If DEG API = Petroleum Measurement Tables 1980 Tables 5C and 6C.</p> <p>If CH.11 2004/7 Cust = API MPMS Chapter 11 2004.</p> <p>If CH.11 2004/, Metric = API MPMS Chapter 11 2004.</p> <p><b>Note:</b> Table 53C is not implemented as the assumption is made that the base density is already known. This is because Table 53C allows for a keypad entry of Alpha, and if this is known then the base density would be known.</p>
<b>D LUBE OILS</b>	<p>Selection is based on the value in the Density Table Units field:</p> <p>If Density Table Units = KG/M3 and reference temperature = 15 Deg C, Petroleum Measurement Tables 1982 Tables 53D and 54D.</p> <p>If Density Table Units = KG/M3 and reference temperature = 20 Deg C, Petroleum Measurement Tables 1988 Tables 59D and 60D.</p> <p>If SG = Petroleum Measurement Tables 1982 Tables 23D and 24D.</p> <p>If DEG API = Petroleum Measurement Tables 1982 Tables 5D and 6D.</p> <p>If CH.11 2004/7, Cust = API MPMS Chapter 11 2004.</p> <p>If CH.11 2004/7, Metric = API MPMS Chapter 11 2004.</p>
<b>LIGHT 1986</b>	<p>ASTM-IP-API Petroleum Measurement Tables for Light Hydrocarbon Liquids 1986 Tables 53 and 54.</p>
<b>ASTM-IP 1952</b>	<p>ASTM-IP Petroleum Measurement Tables 1952 Tables 23, 24, 53 and 54.</p> <p><b>Note:</b> The output is based on the relevant formula or look up tables dependent on the density input.</p>

Field	Description
<b>TABLE LOOKUP</b>	S600+ reads values from a file in the Config600 3.0/Config/Project Name/extras directory and transfers that data into the S600+ with the configuration file. The default files hold values for the ASTM-IP Petroleum Measurement Tables 1952 Tables 5 and 6.
<b>USER K0K1</b>	Selection is based on the value in the Density Table Units field: If KG/M3 = Petroleum Measurement Tables 1980 Tables 53A and 54A with user entered values for K0 and K1. If SG = Petroleum Measurement Tables 1980 Tables 23A and 24A with user entered values for K0 and K1. If DEG API = Petroleum Measurement Tables 1980 Tables 5A and 6A with user entered values for K0 and K1.
<b>LIGHT TP25</b>	GPA TP-25 1998 (API Tables 23E and 24E).
<b>LIGHT TP27</b>	GPA TP-27 2007 (API Tables 23E, 24E, 53E, 54E, 59E and 60E).
<b>AROMATIC S D1555M-95</b>	ASTM D1555-95 Table lookup.
<b>AROMATIC S D1555M-00</b>	ASTM D1555M-00 Table Lookup.
<b>AROMATIC S D1555M-04A</b>	ASTM D1555-04a Calculation.
<b>AROMATIC S D1555M-08</b>	ASTM D1555M-08 Calculation.
<b>STO5.9 08 B1 UGC</b>	Gazprom STO-5.9 2008 Addendum B.1 Unstable Gas Condensate.
<b>STO5.9 08 B2 SLH</b>	Gazprom STO-5.9 2008 Addendum B.2 Stable Liquid Hydrocarbon.
<b>STO5.9 08 B3 WFLH</b>	Gazprom STO-5.9 2008 Addendum B.3 Wide Fraction Liquid Hydrocarbon.
<b>CPL Calculation</b>	Indicates the specific CPL calculation the S600+ uses. Click ▼ to display all valid values. <b>Note:</b> This field <b>does not</b> display if you select <b>CH.11 2004 CUST</b> or <b>CH.11 2004 METRIC</b> as the Density Table Units <b>or</b> one of the Gazprom options as Product Type because these standards also specify the CPL calculation.
<b>OFF</b>	No CPL calculation.
<b>API121</b>	Use API MPMS Ch.11.2.1 1984.
<b>API1121M</b>	Use API MPMS Ch. 11.2.1M 1984. This is the <b>default</b> .
<b>API122</b>	Use API MPMS Ch.11.2.2 1986
<b>API122M</b>	Use API MPMS Ch.11.2.2M 1986

Field	Description
	<b>CONSTANT</b> Use a value you enter.
	<b>DOWNER</b> Use calculations specified in L. Downer's 1979 paper <i>Generation of New Compressibility Tables for International Use</i>
<b>Rounding</b>	Indicates whether the S600+ rounds the calculation results. Click ▼ to display all valid values.
	<b>OFF</b> No rounding occurs. This is the <b>default</b> .
	<b>NATIVE</b> Round to the rules specified in the selected calculation standard.
	<b>API Ch.12.2 Part 2</b> Round in accordance with API MPMS Ch. 12.2 Part 2 – Measurement Tickets 1995
	<b>API Ch.12.2 Part 3</b> Round in accordance with API MPMS Ch. 12.2 Part 3 – Proving Reports 1998
	<b>Flocheck</b> Round in accordance with Emerson Flocheck verification software package
	<b>ASTM D1250-04 Ch.11</b> Round in accordance with API MPMS Ch. 11.1 2004 (ASTM D1250-04) method to round to the Petroleum Measurement Table 1980 Tables
	<b>DECC 1980</b> DTI/DECC requirements for Petroleum Measurement Tables 1980 Tables. No rounding occurs and an iteration tolerance of 0.0001.
<b>Reference Temp</b>	Sets, in degrees Centigrade, the reference temperature for the correction calculations. The default is <b>15</b> degrees C.
<b>Alpha</b>	Sets the coefficient of thermal expansion. The default is <b>0</b> .
<b>FFactor</b>	Sets the compressibility factor for the liquid (also known as the beta factor). The default is <b>0</b> .
<b>PE Calculation</b>	Sets the option to calculate the fluid's Equilibrium Vapour Pressure. While this is normally assumed to be 0, you can use it for natural gas liquids (NGL) and similar applications. Click ▼ to display all valid values.
	<b>OFF</b> Do not calculate PE value. This is the <b>default</b> .
	<b>GPA TP-15 1988 Equation 2</b> Use the GPA TP-15 1988 Equation 2
	<b>GPA TP-15 2003 Equation 2</b> Use the GPA TP-15 2003 Equation 2
	<b>GPA TP-15 1988 Equation 3</b> Use the GPA TP-15 1988 Equation 3
	<b>GPA TP-15 2003 Equation 3</b> Use the GPA TP-15 2003 Equation 3
<b>BASE DENSITY</b>	Click to display a Calculation Result dialog box you use to define the mode, keypad value, and the specific alarm limits for base density. <b>Note:</b> The label on this button changes depending on the configuration.

Field	Description
<b>BASE DENS (DT)</b>	Click to display a Calculation Result dialog box you use to define the mode, keypad value, and the specific alarm limits for base density. <b>Note:</b> This button displays <b>only</b> if you select the density to stream option.

Table 6-2. Standard Density Correction Product Selection

Density Units	Product Type									
	ASTM-IP 1952	A Crude	B Refined	C Special	D Lube Oils	Light 1986	Light TP25	Light TP27	Table Lookup	User K0 K1
<b>DEG API</b>	ASTM D1250 (1952) Table 6	ASTM D1250-80 Table 6A	ASTM D1250-80 Table 6B	ASTM D1250-80 Table 6C	ASTM D1250-80 Table 6D	n/a	n/a	n/a	User lookup table	ASTM D1250-80 Table 6A/ User K0,K1
<b>S.G.</b>	ASTM D1250 (1952) Table 24	ASTM D1250-80 Table 24A	ASTM D1250-80 Table 24B	ASTM D1250-80 Table 24C	ASTM D1250-80 Table 24D	n/a	GPA TP-25/ 1988 Table 24E	GPA TP-27 Table 24E	User lookup table	ASTM D1250-80 Table 24A/ User K0,K1
<b>KG/M3</b>	ASTM D1250 (1952) Table 54	ASTM D1250-80 Table 54A IP Paper 3 (1988) Table 60A (20°C Reference Temp)	ASTM D1250-80 Table 54B IP Paper 3 (1988) Table 60B (20°C Reference Temp)	ASTM D1250-80 Table 54C	ASTM D1250-80 Table 54D IP Paper 3 (1988) Table 60D (20°C Reference Temp)	ASTM-IP-API Petroleum Measurement tables for light hydrocarb on liquids 1986	n/a	GPA TP-27 Table 54E GPA TP-27 Table 60E (20°C Reference Temp)	User lookup table	ASTM D1250-80 Table 54A/ User K0,K1
<b>CH. 11 2004/7 CUST</b>	n/a	ASTM D1250-04	ASTM D1250-04	ASTM D1250-04	ASTM D1250-04	n/a	n/a	n/a	n/a	n/a
<b>CH. 11 2004/7 Metric</b>	n/a	ASTM D1250-04	ASTM D1250-04	ASTM D1250-04	ASTM D1250-04	n/a	n/a	n/a	n/a	n/a
<b>NORSOK I-105</b>	ASTM D1250-04	ASTM D1250-04	ASTM D1250-04	ASTM D1250-04	ASTM D1250-04	ASTM D1250-04	ASTM D1250-04	ASTM D1250-04	ASTM D1250-04	ASTM D1250-04

3. Click any of the following buttons to define **live inputs** for the density correction calculation:

Button	Description
<b>MTR TEMP</b>	Displays a Calculation Result dialog box you use to define the mode, keypad value, and the specific alarm limits for the correction of the temperature of the liquid at the meter (CTL <sub>m</sub> ). <b>Note:</b> The label on this button changes depending on the configuration.
<b>SEL TEMP</b>	Displays a Calculation Result dialog box you use to define the mode, keypad value, and the specific alarm limits for the correction of the temperature of the liquid at the meter (CTL <sub>m</sub> ). <b>Note:</b> The label on this button changes depending on the configuration.
<b>MTR PRESS</b>	Displays a Calculation Result dialog box you use to define the mode, keypad value, and the specific alarm limits for the correction of the pressure of the liquid at the meter (CPL <sub>m</sub> ). <b>Note:</b> The label on this button changes depending on the configuration.
<b>SEL PRESS</b>	Displays a Calculation Result dialog box you use to define the mode, keypad value, and the specific alarm limits for the correction of the pressure of the liquid at the meter (CPL <sub>m</sub> ). <b>Note:</b> The label on this button changes depending on the configuration.

Button	Description
<b>MTR Pe</b>	Displays a Calculation Result dialog box you use to define the mode, keypad value, and the specific alarm limits for the equilibrium vapour pressure (Pe). <b>Note:</b> The label on this button change depending on the configuration.
<b>Pe</b>	Displays a Calculation Result dialog box you use to define the mode, keypad value, and the specific alarm limits for observed equilibrium vapour pressure (Pe). <b>Note:</b> The label on this button changes depending on the configuration.

- Click any of the following buttons to define **calculation results** for the density correction calculation:

Button	Description
<b>METER DENSITY</b>	Displays a Calculation Result dialog box you use to define the mode, keypad value, and the specific alarm limits for meter density. <b>Note:</b> The label on this button changes depending on the configuration.
<b>MTR DENS (DT)</b>	Displays a Calculation Result dialog box you use to define the mode, keypad value, and the specific alarm limits for observed density. <b>Note:</b> The label on this button changes depending on the configuration.

- Click in the hierarchy menu when you finish defining settings. A confirmation dialog box displays.
- Click **Yes** to apply your changes. The PCSetup screen displays.

### 6.7.6 Base Sediment and Water (BSW)

This option provides base sediment and water (BSW) settings for the calculation of the net volume totals.

- Select **BSW** from the hierarchy menu. The BSW screen displays.



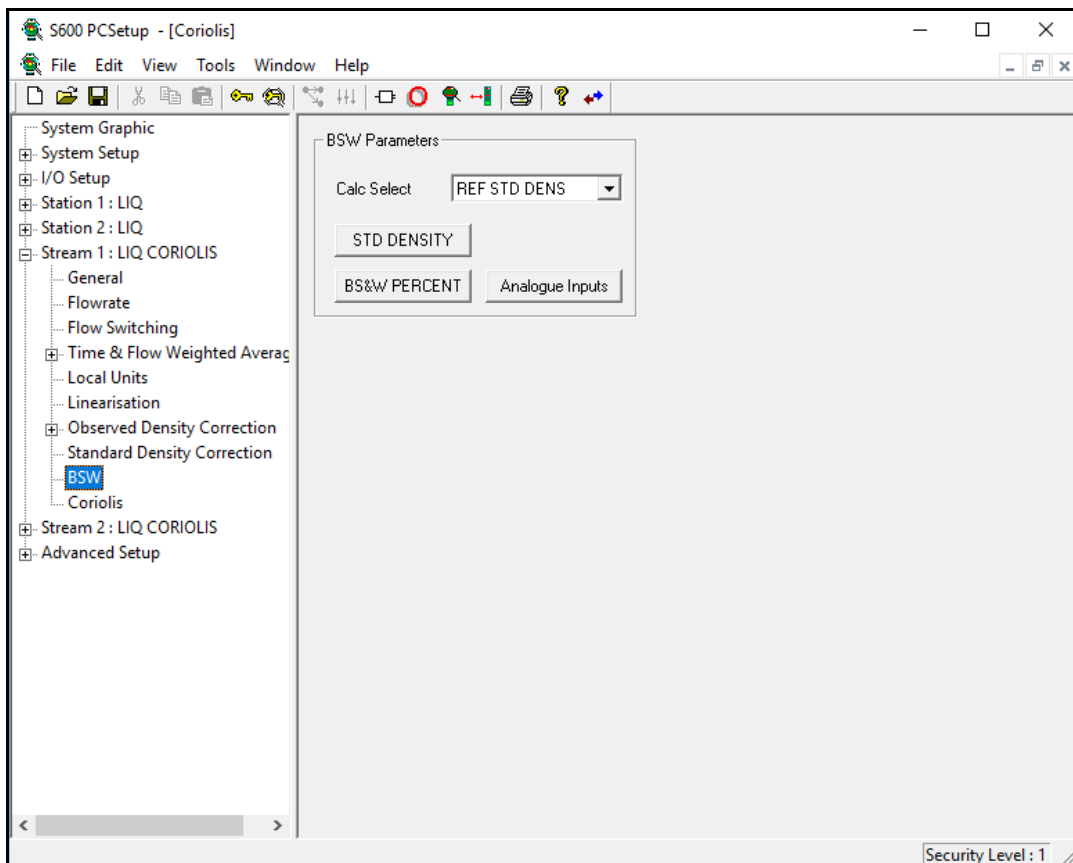

Figure 6-94. BSW screen

2. Complete the following fields.

Field	Description
<b>Calc Select</b>	Indicates the standard the S600+ uses for the BSW calculations. Click ▼ to display all valid values.
<b>IP VII/2 4.12</b>	Use IP VII/2 4.12 standard. This is the <b>default</b> .
<b>REF METER DENS</b>	Use the meter density; mass = meter dry volume * meter density.
<b>REF STD DENS</b>	Use the standard density; mass = std dry volume * std density.
<b>US METHOD 1</b>	Use the meter density; mass = meter wet volume * meter density.
<b>NORSOK I-105</b>	Use Norsok I-105 Appendix D method of computing totals. This <b>must</b> be used in conjunction with Norsok I-105 Density Table Units option.

### 6.7.7 Coriolis

Coriolis settings define the constants and calculation limits for a range of parameters, including stream input sources and modes of operation.

These settings also allow you to define alarms. The system activates these alarms when the calculated results for the flowrates are not within specified limits.

1. Select **Coriolis** from the hierarchy menu. The Coriolis screen displays.

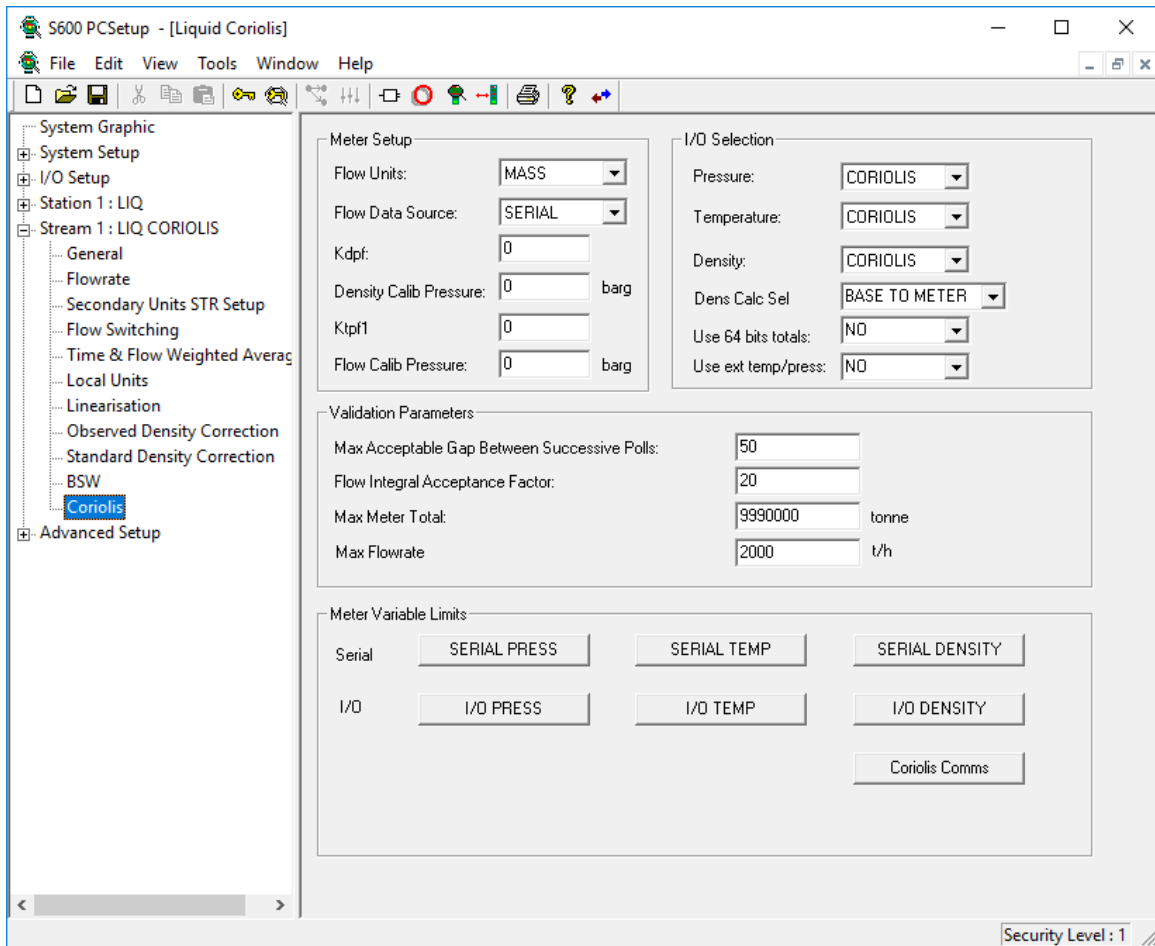

Figure 6-95. Coriolis screen

2. Complete the following fields.

Field	Description
<b>Flow Units</b>	Indicates the primary flow units measurements. Valid values are <b>MASS</b> (configure the Coriolis meter for mass-based input) or <b>VOLUME</b> (configure the meter for volume-based inputs). The default is <b>MASS</b> .
<b>Flow Data Source</b>	Indicates the source of flow data. Valid values are <b>SERIAL</b> (enable the system to take the primary variable from the serial mass or volume flowrate) or <b>PULSE I/P</b> (calculate the primary variable from the mass or volume pulse input.). The default is <b>SERIAL</b> .
<b>Kdpf</b>	Sets a density correction factor value. The default is <b>0</b> . <b>Note:</b> Please contact your Coriolis supplier or reference the supplied calibration sheet for more information regarding this field and value.
<b>Density Calib Pressure</b>	Sets a density calibration pressure value. The default is <b>0</b> . <b>Note:</b> Please contact your Coriolis supplier or reference the supplied calibration sheet for more information regarding this field and value.

Field	Description
<b>Ktpf1</b>	<p>Sets a pulse correction factor value. The default is <b>0</b>.</p> <p><b>Note:</b> Please contact your Coriolis supplier or reference the supplied calibration sheet for more information regarding this field and value.</p>
<b>Flow Calib Pressure</b>	<p>Sets a flow calibration pressure value. The default is <b>0</b>.</p> <p><b>Note:</b> Please contact your Coriolis supplier or reference the supplied calibration sheet for more information regarding this field and value.</p>
<b>Pressure</b>	<p>Indicates the source of pressure I/O. Valid values are <b>CORIOLIS</b> (use data from the Coriolis serial link) or <b>I/O</b> (use data either from ADC/PRT/Density inputs [if correctly configured] or from the Coriolis serial link [if incorrectly configured]). The default is <b>CORIOLIS</b>.</p> <p><b>Note:</b> If you select <b>I/O</b>, remember to configure the analog inputs.</p>
<b>Temperature</b>	<p>Indicates the source of temperature I/O. Valid values are <b>CORIOLIS</b> (use data from the Coriolis serial link) or <b>I/O</b> (use data either from the ADC/PRT/Density inputs [if correctly configured] or from the Coriolis serial link [if incorrectly configured]). The default is <b>CORIOLIS</b>.</p> <p><b>Note:</b> If you select <b>I/O</b>, remember to configure the analog inputs.</p>
<b>Density</b>	<p>Indicates the source of density I/O. Valid values are <b>CORIOLIS</b> (use data from the Coriolis serial link) or <b>I/O</b> (use data either from the ADC/PRT/Density inputs [if correctly configured] or from the Coriolis serial link [if incorrectly configured]). The default is <b>CORIOLIS</b>.</p> <p><b>Note:</b> If you select <b>I/O</b>, remember to configure the densitometer.</p>
<b>Density Calc Sel</b>	<p>Indicates whether the S600+ uses the density from the Coriolis meter or from a station densitometer (if configured). Valid values are <b>BASE TO METER</b> for a station densitometer or <b>METER TO BASE</b> for the Coriolis value. <b>BASE TO METER</b> is the default.</p>
<b>Use 64 bit totals</b>	<p>Indicates whether the S600+ uses the 64-bit totals received from the Coriolis meter in totalisation routines.</p> <hr/> <p><b>NO</b> Use the 32-bit totals received from the Coriolis meter. This is the <b>default</b>.</p> <hr/> <p><b>YES</b> Use the 64-bit totals received from the Coriolis meter.</p>
<b>Use ext temp/press</b>	<p>Indicates which serial temperature and pressure values the S600+ uses in calculations.</p> <p><b>Note:</b> This is valid <b>only</b> if the temperature and pressure I/O selections are set to <b>CORIOLIS</b>.</p> <hr/> <p><b>NO</b> Use the internally derived temperature and pressure values. This is the <b>default</b>.</p> <hr/> <p><b>YES</b> Use the external temperature and pressure input values.</p>
<b>Max Acceptable Gap Between Successive Polls</b>	<p>Sets, in seconds, the maximum acceptable gap between successive polls. The default is <b>50</b>. The system uses this value to determine communication failures.</p>

Field	Description
<b>Flow Integral Acceptance Factor</b>	Sets the acceptable tolerance factor for comparing flowrate to elapsed totals. The default is <b>20</b> .
<b>Max Meter Total</b>	Sets a maximum allowable increment in the received total. Used by the increment validation logic.
<b>Max Flowrate</b>	Sets a maximum allowable flowrate. The default is <b>500</b> .

- Click any of the following buttons to set meter variable limits.

Button	Description
<b>SERIAL PRESS</b>	Click to display a Calculation Result dialog box you use to define the mode, keypad value, and the specific alarm limits for serial pressure.
<b>SERIAL TEMP</b>	Click to display a Calculation Result dialog box you use to define the mode, keypad value, and the specific alarm limits for serial temperature.
<b>SERIAL DENSITY</b>	Click to display a Calculation Result dialog box you use to define the mode, keypad value, and the specific alarm limits for serial density.
<b>I/O PRESSURE</b>	Click to display an Analog Input dialog box you use to define various values for the analog input.
<b>I/O TEMPERATURE</b>	Click to display an Analog Input dialog box you use to define various values for the analog input.
<b>I/O DENSITY</b>	Click to display a Calculation Result dialog box you use to define the mode, keypad value, and the specific alarm limits for I/O density.
<b>Coriolis Comms</b>	Click to display the I/O Setup screen in Comms.

- Click in the hierarchy menu when you finish defining settings. A confirmation dialog box displays.
- Click **Yes** to apply your changes. The PCSetup screen displays.

## 6.8 Liquid – Turbine

---

These stream settings are specific to liquid applications using turbine meters. When you initially create a configuration, the calculation selections you make determine which calculation-specific screens appear in the hierarchy menu.



### Caution

**It is extremely unlikely that any one S600+ configuration would contain all the settings discussed in this section. For that reason, several sample configurations demonstrate the settings.**

---

### 6.8.1 Local Units

This option allows you to override the global K-factor unit as a liquid application may have more than one type of meter, each using different K-factor units.

- Select **Local Units** from the hierarchy menu. The Local Units screen displays.

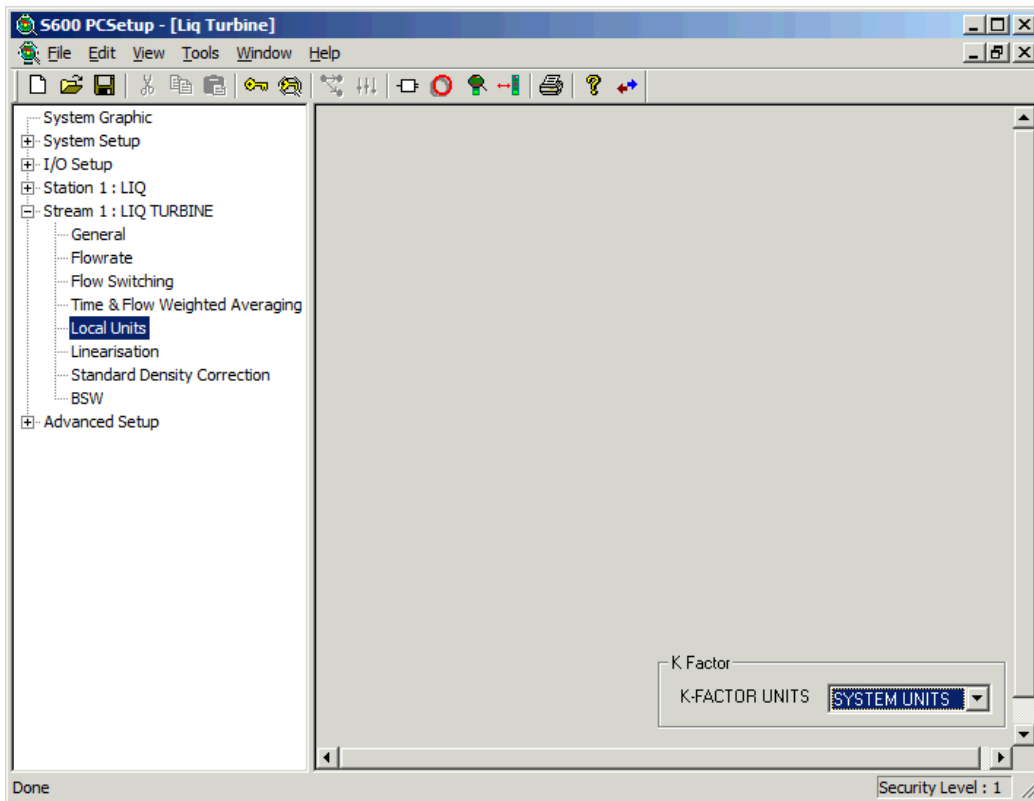

Figure 6-96. Local Units screen

2. Complete the following field.

Field	Description
<b>K-factor Units</b>	Indicates the type of units you desire to use and override the system K-factor units of measurement. Click ▼ to display all valid values. The default is <b>SYSTEM UNITS</b> . <b>Note:</b> If you select System Units, the stream uses the global default value.

3. Click in the hierarchy menu when you finish defining settings. A confirmation dialog box displays.
4. Click **Yes** to apply your changes. The PCSetup screen displays.

## 6.8.2 Linearisation

Linearisation settings define the constants and calculation limits for the meter factor and the K-factor typically taken from a Meter Calibration Certificate. The system calculates a meter factor and K-factor corresponding to the turbine frequency by interpolating the frequency between fixed points and then cross-referencing this value to a look-up table. and the K-factor.

Flow meters produce pulses proportional to the total flow through the meter. The K-factor represents the number of pulses produced per unit volume.

Linearisation settings also allow you to define alarms. The system activates these alarms when the calculated results for the meter factor and K-factor are not within the specified limits.

---

**Notes:**

- The linearisation curve for Liquid Turbine configurations uses IVOL Flow Rate as the default input for both K-factor and Meter Factor calculations. The ability to change the defaults is available **only** with Config600 Pro software.
- Batching systems that employ meter factor or K-factor linearisation with retrospective meter factor/K-factor adjustments assume that the adjusted value has a "keypad" mode.
- To prevent the live metering system from applying a double correction, use **either** a calculated meter factor **or** a calculated K-factor linearisation (that is, only one factor should have a calculated mode).

- 
1. Select **Linearisation** from the hierarchy menu. The Linearisation screen displays.

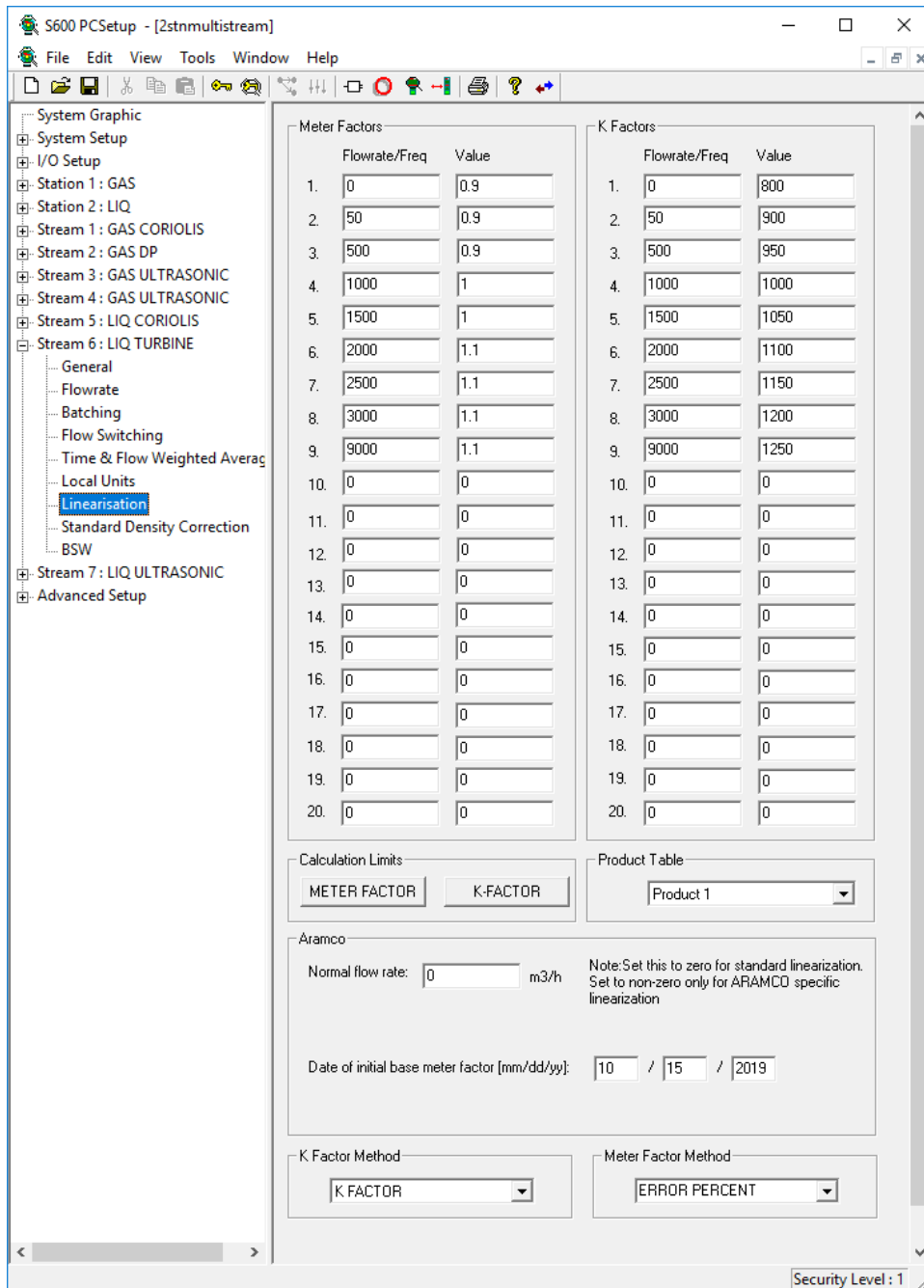

Figure 6-97. Linearisation screen

2. Complete the following fields.

Field	Description
<b>Meter Factors</b>	Sets up to 12 flow rate and values for the meter correction factors.
<b>Flowrate/Freq</b>	Set the flowrate and frequency for each of the meter correction factors.
<b>Value</b>	Set the corresponding values for each of the meter factors.
<b>K Factors</b>	Sets up to 10 flow rate and values for the K-factors.
<b>Flowrate/Freq</b>	Set the flowrate and frequency for each of the K-factors.
<b>Value</b>	Set the corresponding values for each of the K-factors.

Field	Description
<b>METER FACTOR</b>	Click to display a Calculation Result dialog box you use to define the mode, keypad value, and the specific alarm limits for the respective factor.
<b>K-FACTOR</b>	Click to display a Calculation Result dialog box you use to define the mode, keypad value, and the specific alarm limits for the respective factor.
<b>Product Table</b>	It allows the selection of the “default” Product Table (the in-use functionality) and the 16 other Product Tables in order to set up to 10 flow rates and values for the meter correction factors and K-factors for each product type. When you select a specific product, the meter factors and K-factors update accordingly. <b>Note:</b> This field displays <b>only</b> if you enable the Product Table when you create the configuration.
<b>Aramco</b>	Aramco-style linearisation is identical to normal linearisation, but is only used to generate the first meter factor – subsequent meter factors are generated from proving. <b>Notes:</b> <ul style="list-style-type: none"> <li>▪ Ignore the fields in the Aramco frame unless directed by technical support.</li> <li>▪ You <b>must</b> select Product Table with History when you create your configuration in order to use the Prover MF Deviation Check stage.</li> </ul>
<b>Normal Flow Rate</b>	Set to zero for standard linearisation. Set to non-zero <b>only</b> for Aramco-style linearisation. <b>Note:</b> For Aramco-style linearisation <b>only</b> , the Initial Meter Factor is calculated from the linearisation curve and the Normal Flow Rate. This Initial Meter Factor is then used in the subsequent proving functionality.
<b>Date of Initial Base Meter Factor</b>	Set the time stamp of the initial base meter factor. <b>Note:</b> This field displays <b>only</b> if you enable the Product Table with History when you create the configuration.
<b>K Factor Method</b>	Selectable between K FACTOR (values entered as normal) and ERROR PERCENT (K Factor entered as a percentage).
<b>Meter Factor Method</b>	Selectable between METER FACTOR (values entered as normal) and ERROR PERCENT (Meter Factor entered as a percentage).

3. Click in the hierarchy menu when you finish defining settings. A confirmation dialog box displays.
4. Click **Yes** to apply your changes. The PCSetup screen displays.

### 6.8.3 Sampling

Sampling settings define the method and interval period for sampling product from a flowing pipeline. By default, the S600+ supports one



sampler per stream. If you require more than one sampler per stream, contact Technical Support personnel. Config600 uses the following stages during the sampling process:

Stage	Description
0	Idle
1	Monitor
2	Digout n
3	Min Intvl
4	Post Pulse
5	Stopped Manually
6	Stopped Can Full
7	Stopped Low Flow
8	Initial Time
9	Check Flow Switch
10	Stopped Flow Switch
11	Stopped Press Switch
12	Stopped initialise
13	Can Switch Over

**Note:** Batch auto-resets the sampler at the start of the batch.

1. Select **Sampling** from the hierarchy menu. The Sampling screen displays.

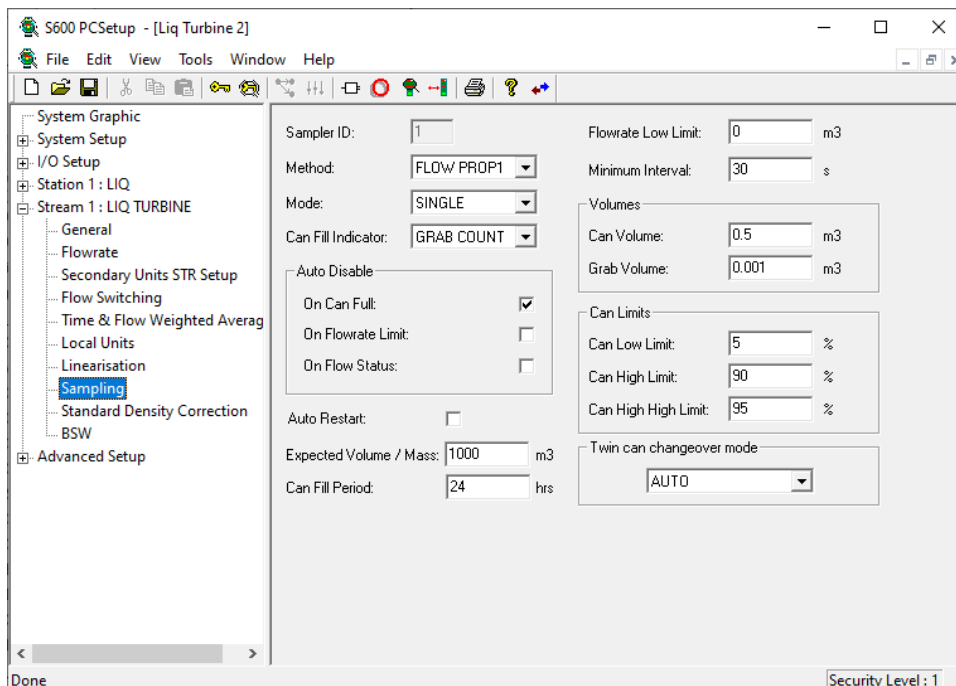

Figure 6-98. Sampling screen

2. Complete the following fields.

Field	Description
<b>Sampler ID</b>	Provides an identifying label for the sampler. Each stream or station must have a unique sampler ID.
<b>Method</b>	Indicates the sampling method. Click ▼ to display all valid values.

Field	Description
	<p><b>TIME PROP</b> Divides the value in the Can Fill Period field by the number of grabs needed to fill the can (derived from the Can Volume and Fill Volume values) to determine a time interval per pulse. This is the <b>default</b>.</p>
	<p><b>FLOW PROP1</b> Divides the value in the Volume field by the number of grabs needed to fill the can (derived from the Can Volume and Fill Volume values) to determine a volume throughput per pulse.</p>
	<p><b>FLOW PROP2</b> Uses the value in the Volume field as the volume throughput per pulse.</p>
	<p><b>FLOW PROP3</b> Uses the value in the Volume field as the volume throughput per pulse, but supports low pressure digital input and pump prime output.</p>
<b>Mode</b>	Indicates the sampling mode. Click ▼ to display all valid values. The default is <b>SINGLE</b> .
<b>Can Fill Indicator</b>	Indicates how the S600+ determines when the sampling can is full. Click ▼ to display all valid values. The default is <b>GRAB COUNT</b> .
	<p><b>GRAB COUNT</b> Uses the number of pulses output during the sample to determine when the can is full.</p>
	<p><b>DIG I/P</b> Uses a digital input to determine when the can is full.</p>
	<p><b>ANALOG I/P</b> Uses an analog input to determine when the can is full.</p>
<b>Auto Disable</b>	Indicates the event at which the system automatically disables the sampling process. Select the appropriate check box to identify the specific event.
<b>Auto Restart</b>	Indicates whether the system automatically restarts sampling after automatically disabling sampling.
<b>Expected Volume/Mass</b>	Sets the volume or mass of the sampling can. The default is <b>1000</b> .
<b>Can Fill Period</b>	Sets, in hours, the time required to fill the sampling can. The default is <b>24</b> . <b>Note:</b> This field is required for the TIME PROP sampling method.
<b>Flowrate Low Limit</b>	Sets the volume at which automatic disabling occurs. The default is <b>0</b> . <b>Note:</b> This field is required if you select the On Flowrate Limit check box for Auto Disable.
<b>Minimum Interval</b>	Sets the minimum interval, in seconds, for sampling. The default is <b>30</b> . <b>Note:</b> If the sample exceeds this limit, the system sets the overspeed alarm and increments the overspeed counter.
<b>Can Volume</b>	Sets the volume of the sampling can. The default is <b>0.5</b> .
<b>Grab Volume</b>	Sets the volume of each sampling grab. The default is <b>0.001</b> .
<b>Can Low Limit</b>	Sets the low limit alarm as a percentage of the Can

Field	Description
	Volume. The default is <b>5</b> .
<b>Cam High Limit</b>	Sets the high limit alarm as a percentage of the Can Volume. The default is <b>90</b> .
<b>Can High High Limit</b>	Sets the high high alarm as a percentage of the Can Volume. The default is <b>95</b> .
<b>Twin Can Changeover Mode</b>	Indicates the changeover method for twin can sampling. Click ▼ to display all valid values.
	<b>AUTO</b> The sampler automatically changes over to the second can when the first is full.
	<b>MANUAL</b> The sampler pauses sampling when the first can is full and requires the operator to change the value of Can Selected before sampling continues on the second can.
	<b>Note:</b>
	<ul style="list-style-type: none"> <li>▪ If sampling is stopped because both cans are full, the Twin Can Changeover Mode is set to MANUAL by the system. The user must set back to AUTO if required.</li> <li>▪ The display for Twin Can Changeover must be manually added to the displays.</li> </ul>

3. Click in the hierarchy menu when you finish defining settings. A confirmation dialog box displays.
4. Click **Yes** to apply your changes. The PCSetup screen displays.

#### 6.8.4 Observed Density Correction

This option enables you to determine base density from measured density. The system uses base density, coordinated with the standard density correction, to calculate correction values for the temperature of the liquid at the meter ( $CTL_m$ ) and the pressure of the liquid at the meter ( $CPL_m$ ). The system then uses the  $CTL_m$  and  $CPL_m$  values to correct the metered volume to reference conditions.

You can measure density at the header, which is associated with the station because it is a common density available to all streams (OBS TEMP and OBS PRESS), or you can measure it at the meter, which is associated with a specific stream (MTR TEMP and MTR PRESS). If you do not measure density, this screen does not display and you enter a density at standard conditions.

**Note:** Options selected when the configuration was created determine whether the screen for standard density or observed density displays. This example configuration only shows observed density correction. For standard density settings, see either the example for Coriolis stream or Liquid Ultrasonic stream.

1. Select **Observed Density Correction** from the hierarchy menu. The Observed Density Correction screen displays.

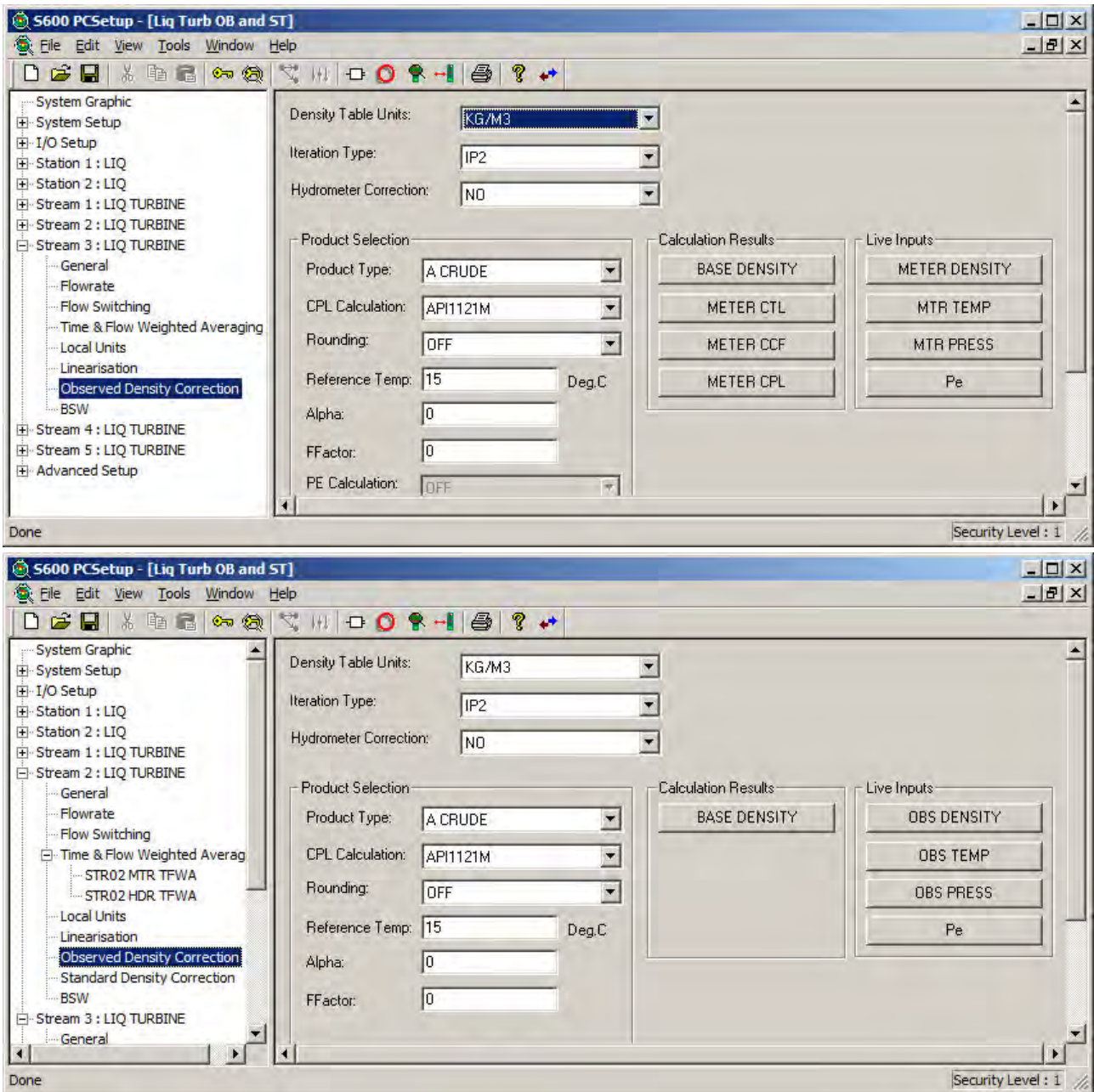

Figure 6-99. Observed Density Correction screens

2. Complete the following fields.

Field	Description
<b>Density Table Units</b>	Indicates the density units the S600+ uses for the density correction calculations. Click ▼ to display all valid values.
<b>CH. 11 2004/7 CUST</b>	Use API MPMS Chapter 11.1 2004, Addendum 1, 2007 Imperial Units.
<b>CH. 11 2004/7 METRIC</b>	Use API MPMS Chapter 11.1 2004, Addendum 1, 2007 Metric Units.
<b>DEG API</b>	Use degrees API.
<b>KG/M3</b>	Use kilograms per cubic meter. This is the <b>default</b> .
<b>S.G.</b>	Use specific gravity.
<b>NORSOK I-105</b>	Use Norsok I-105 Appendix D density correction.

Field	Description
<b>Iteration Type</b>	Indicates the iteration type for the density correction calculations. Valid values are <b>ASTM</b> (use the iterative temperature and pressure correction as defined by ASTM/API, Chapter 12) or <b>IP2</b> (use the iterative temperature and pressure correction as defined in IP 2 [ISO 91-1]). The <b>default</b> is <b>ASTM</b> .
<b>Hydrometer Correction</b>	Indicates whether the S600+ applies hydrometer correction values to the calculation. Valid values are <b>YES</b> and <b>NO</b> ; the default is <b>NO</b> .
<b>Product Type</b>	Indicates the type of petroleum product involved in the calculation. Click ▼ to display all valid values. The <b>default</b> is <b>A CRUDE</b> .
<b>A CRUDE</b>	<p>Selection is based on the value in the Density Table Units field:</p> <p>If Density Table Units = KG/M3 and reference temperature = 15 Deg C, Petroleum Measurement Tables 1980 Tables 53A and 54A.</p> <p>If Density Table Units = KG/M3 and reference temperature = 20 Deg C, Petroleum Measurement Tables 1988 Tables 59A and 60A.</p> <p>If SG = Petroleum Measurement Tables 1980 Tables 23A and 24A.</p> <p>If DEG API = Petroleum Measurement Tables 1980 Tables 5A and 6A.</p> <p>If CH.11 2004/7, Cust = API MPMS Chapter 11 2004.</p> <p>If CH.11 2004/7, Metric = API MPMS Chapter 11 2004.</p>
<b>B REFINED</b>	<p>Selection is based on the value in the Density Table Units field:</p> <p>If Density Table Units = KG/M3 and reference temperature = 15 Deg C, Petroleum Measurement Tables 1980 Tables 53B and 54B.</p> <p>If Density Table Units = KG/M3 and reference temperature = 20 Deg C, Petroleum Measurement Tables 1988 Tables 59B and 60B.</p> <p>If SG = Petroleum Measurement Tables 1980 Tables 23B and 24B.</p> <p>If DEG API = Petroleum Measurement Tables 1980 Tables 5B and 6B.</p> <p>If CH.11 2004/7, Cust = API MPMS Chapter 11 2004.</p> <p>If CH.11 2004/7, Metric = API MPMS Chapter 11 2004.</p>

Field	Description
<b>C SPECIAL</b>	<p>Selection is based on the value in the Density Table Units field:</p> <p>If KG/M3 = Petroleum Measurement Tables 1980 Tables 54C.</p> <p>If SG = Petroleum Measurement Tables 1980 Tables 23C and 24C.</p> <p>If DEG API = Petroleum Measurement Tables 1980 Tables 5C and 6C.</p> <p>If CH.11 2004/7, Cust = API MPMS Chapter 11 2004.</p> <p>If CH.11 2004/7, Metric = API MPMS Chapter 11 2004.</p> <p><b>Note:</b> Table 53C is not implemented as the assumption is made that the base density is already known. This is because Table 53C allows for a keypad entry of Alpha, and if this is known then the base density would be known.</p>
<b>D LUBE OILS</b>	<p>Selection is based on the value in the Density Table Units field:</p> <p>If Density Table Units = KG/M3 and reference temperature = 15 Deg C, Petroleum Measurement Tables 1982 Tables 53D and 54D.</p> <p>If Density Table Units = KG/M3 and reference temperature = 20 Deg C, Petroleum Measurement Tables 1988 Tables 59D and 60D.</p> <p>If SG = Petroleum Measurement Tables 1982 Tables 23D and 24D.</p> <p>If DEG API = Petroleum Measurement Tables 1982 Tables 5D and 6D.</p> <p>If CH.11 2004/7, Cust = API MPMS Chapter 11 2004.</p> <p>If CH.11 2004/7, Metric = API MPMS Chapter 11 2004.</p>
<b>LIGHT 1986</b>	<p>ASTM-IP-API Petroleum Measurement Tables for Light Hydrocarbon Liquids 1986 Tables 53 and 54.</p>
<b>ASTM-IP 1952</b>	<p>ASTM-IP Petroleum Measurement Tables 1952 Tables 23, 24, 53 and 54 (Algorithm).</p> <p><b>Note:</b> The output is based on the relevant formula or look up tables dependent on the density input.</p>

Field	Description
<b>TABLE LOOKUP</b>	<p>S600+ reads values from a file in the Config600 3.x/Config/Project Name/extras directory and transfers that data into the S600+ with the configuration file. The specific file selected is based on the value in the Density Table Units field:</p> <p>If <b>SG</b>, values are read from the ASTM-IP Petroleum Measurement Tables 1952 Tables 23 file.</p> <p>If <b>DEG API</b>, values are read from the ASTM-IP Petroleum Measurement Tables 1952 Tables 5 file.</p> <p>For <b>KG/M3</b>, please consult technical support.</p>
<b>USER K0 K1</b>	<p>Selection is based on the value in the Density Table Units field:</p> <p>If KG/M3 = Petroleum Measurement Tables 1980 Tables 53A and 54A with user entered values for K0 and K1.</p> <p>If SG = Petroleum Measurement Tables 1980 Tables 23A and 24A with user entered values for K0 and K1.</p> <p>If DEG API = Petroleum Measurement Tables 1980 Tables 5A and 6A with user entered values for K0 and K1.</p>
<b>LIGHT TP25</b>	GPA TP-25 1998 (API Tables 23E and 24E).
<b>LIGHT TP27</b>	GPA TP-27 2007 (API Tables 23E, 24E, 53E, 54E, 59E and 60E).
<b>AROMATICS D1555M-95</b>	ASTM D1555-95 Table lookup.
<b>AROMATICS D1555M-00</b>	ASTM D1555M-00 Table Lookup.
<b>AROMATICS D1555M-04A</b>	ASTM D1555-04a Calculation.
<b>AROMATICS D1555M-08</b>	ASTM D1555M-08 Calculation.
<b>STO5.9 08 B1 UGC</b>	Gazprom STO-5.9 2008 Addendum B.1 Unstable Gas Condensate.
<b>STO5.9 08 B2 SLH</b>	Gazprom STO-5.9 2008 Addendum B.2 Stable Liquid Hydrocarbon.
<b>STO5.9 08 B3 WFLH</b>	Gazprom STO-5.9 2008 Addendum B.3 Wide Fraction Liquid Hydrocarbon.

Field	Description
<b>CPL Calculation</b>	<p>Indicates the specific CPL calculation the S600+ uses. Click ▼ to display all valid values.</p> <p><b>Note:</b> This field <b>does not</b> display if you select <b>CH.11 2004 CUST</b> or <b>CH.11 2004 METRIC</b> as the Density Table Units or one of the Gazprom options as Product Type because these standards also specify the CPL calculation.</p>
<b>OFF</b>	No CPL calculation.
<b>API121</b>	Use API MPMS Ch.11.2.1 1984.
<b>API1121M</b>	Use API MPMS Ch. 11.2.1M 1984. This is the <b>default</b> .
<b>API122</b>	Use API MPMS Ch.11.2.2 1986
<b>API122M</b>	Use API MPMS Ch.11.2.2M 1986
<b>CONSTANT</b>	Use a value you enter.
<b>DOWNER</b>	Use calculations specified in L. Downer's 1979 paper <i>Generation of New Compressibility Tables for International Use</i>
<b>Rounding</b>	<p>Indicates whether the S600+ rounds the calculation results. Click ▼ to display all valid values.</p>
<b>OFF</b>	No rounding occurs. This is the <b>default</b> .
<b>NATIVE</b>	Round to the rules specified in the selected calculation standard.
<b>API Ch.12.2 Part 2</b>	Round in accordance with API MPMS Ch. 12.2 Part 2 – Measurement Tickets 1995
<b>API Ch.12.2 Part 3</b>	Round in accordance with API MPMS Ch. 12.2 Part 3 – Proving Reports 1998
<b>Flocheck</b>	Round in accordance with Emerson Flowcheck verification software package
<b>ASTM D1250-04 Ch.11</b>	Round in accordance with API MPMS Ch.11.1 2004 (ASTM D1250-04) method to round to the Petroleum Measurement Table 1980 Tables
<b>DECC 1980</b>	DTI/DECC requirements for Petroleum Measurement Tables 1980 Tables. No rounding occurs and an iteration tolerance of 0.0001.
<b>Reference Temp</b>	Indicates, in degrees Centigrade, the reference temperature for the correction calculations. The default is <b>15</b> degrees C.
<b>Alpha</b>	Sets the coefficient of thermal expansion. The default is <b>0</b> .
<b>FFactor</b>	Sets the compressibility factor for the liquid (also known as the beta factor). The default is <b>0</b> .



Field	Description
<b>PE Calculation</b>	Sets the option to calculate the fluid's Equilibrium Vapour Pressure. While this is normally assumed to be 0, you can use it for natural gas liquids (NGL) and similar applications. Click ▼ to display all valid values.
<b>OFF</b>	Do not calculate PE value. This is the <b>default</b> .
<b>GPA TP-15 1988 Equation 2</b>	Use the GPA TP-15 1988 Equation 2
<b>GPA TP-15 2003 Equation 2</b>	Use the GPA TP-15 2003 Equation 2
<b>GPA TP-15 1988 Equation 3</b>	Use the GPA TP-15 1988 Equation 3
<b>GPA TP-15 2003 Equation 3</b>	Use the GPA TP-15 2003 Equation 3
<b>Aromatics Type</b>	Sets the type of aromatics product. Click ▼ to display all valid values. The default is <b>Benzene</b> .
<b>Aromatics CCF</b>	Sets the method for calculating a combined corrector factory (CCF) for aromatics products. Valid values are <b>Density</b> (calculate using a density you enter) or <b>Table 1</b> (calculate use a density from an embedded table).

Table 6-3. Observed Density Correction Product Selection

Density Units	Product Type									
	ASTM IP 1952	A Crude	B Refined	C Special	D Lube Oils	Light 1986	Light TP25	Light TP27	Table Lookup	User K0 K1
<b>DEG API</b>	n/a	ASTM D1250-80 Table 5A	ASTM D1250-80 Table 5B	n/a	ASTM D1250-80 Table 5D	n/a	n/a	n/a	ASTM-IP Petroleum Measurement Tables 1952 Tables 5 lookup table	ASTM D1250-80 Table 5A/ User K0,K1
<b>S.G.</b>	ASTM D1250 (1952) Table 23 Algorithm	ASTM D1250-80 Table 23A	ASTM D1250-80 Table 23B	n/a	ASTM D1250-80 Table 23D	n/a	GPA TP-25/ 1988 Table 23E	GPA TP-27 Table 23E	ASTM-IP Petroleum Measurement Tables 1952 Tables 23 lookup table	ASTM D1250-80 Table 23A/ User K0,K1
<b>KG/M3</b>	ASTM D1250 (1952) Table 53 Algorithm	ASTM D1250-80 Table 53A IP Paper 3 (1988) Table 59A (20°C Reference Temp)	ASTM D1250-80 Table 53B IP Paper 3 (1988) Table 59B (20°C Reference Temp)	n/a	ASTM D1250-80 Table 53D IP Paper 3 (1988) Table 59D (20°C Reference Temp)	ASTM-IP-API Petroleum Measurement tables for light hydrocarb on liquids 1986	n/a	GPA TP-27 Table 53E GPA TP-27 Table 59E (20°C Reference Temp)	Consult technical support	ASTM D1250-80 Table 53A/ User K0,K1
<b>CH. 11 2004/7 CUST</b>	n/a	ASTM D1250-04	ASTM D1250-04	ASTM D1250-04	ASTM D1250-04	n/a	n/a	n/a	n/a	n/a
<b>CH. 11 2004/7 METRIC</b>	n/a	ASTM D1250-04	ASTM D1250-04	ASTM D1250-04	ASTM D1250-04	n/a	n/a	n/a	n/a	n/a
<b>NORSOK I-105</b>	ASTM D1250-04	ASTM D1250-04	ASTM D1250-04	ASTM D1250-04	ASTM D1250-04	ASTM D1250-04	ASTM D1250-04	ASTM D1250-04	ASTM D1250-04	ASTM D1250-04

3. Click any of the following buttons to define **calculation results** for the observed density correction calculations.

Button	Description
<b>BASE DENSITY</b>	Displays a Calculation Result dialog box you use to define the mode, keypad value, and the specific alarm limits for base density. <b>Note:</b> The label on this button changes depending on the configuration.
<b>METER CTL</b>	Displays a Calculation Result dialog box you use to define the mode, keypad value, and the specific alarm limits for the correction of the temperature of the liquid at the meter (CTL <sub>m</sub> ). <b>Note:</b> The label on this button changes depending on the configuration.
<b>METER CCF</b>	Displays a Calculation Result dialog box you use to define the mode, keypad value, and the specific alarm limits for the combined correction factor at the meter (CCF <sub>m</sub> ). <b>Note:</b> The label on this button changes depending on the configuration.
<b>METER CPL</b>	Displays a Calculation Result dialog box you use to define the mode, keypad value, and the specific alarm limits for the correction of the pressure of the liquid at the meter (CPL <sub>m</sub> ). <b>Note:</b> The label on this button changes depending on the configuration.

4. Click any of the following buttons to define **live inputs** for the observed density correction calculations.

Button	Description
<b>METER DENSITY</b>	Displays a Calculation Result dialog box you use to define the mode, keypad value, and the specific alarm limits for meter density. <b>Note:</b> The label on this button changes depending on the configuration.
<b>OBS DENS</b>	Displays a Calculation Result dialog box you use to define the mode, keypad value, and the specific alarm limits for observed density. <b>Note:</b> The label on this button changes depending on the configuration.
<b>MTR TEMP</b>	Displays a Calculation Result dialog box you use to define the mode, keypad value, and the specific alarm limits for meter temperature. <b>Note:</b> The label on this button changes depending on the configuration.
<b>OBS TEMP</b>	Displays a Calculation Result dialog box you use to define the mode, keypad value, and the specific alarm limits for observed temperature. <b>Note:</b> The label on this button changes depending on the configuration.
<b>MTR PRESS</b>	Displays a Calculation Result dialog box you use to define the mode, keypad value, and the specific alarm limits for meter pressure. <b>Note:</b> The label on this button changes depending on the configuration.
<b>OBS PRESS</b>	Displays a Calculation Result dialog box you use to define the mode, keypad value, and the specific alarm limits for observed pressure. <b>Note:</b> The label on this button changes depending on the configuration.

Button	Description
Pe	Displays a Calculation Result dialog box you use to define the mode, keypad value, and the specific alarm limits for observed equilibrium vapour pressure (Pe). <b>Note:</b> The label on this button changes depending on the configuration.

- Click in the hierarchy menu when you finish defining settings. A confirmation dialog box displays.
- Click **Yes** to apply your changes. The PCSetup screen displays.

### 6.8.5 Standard Density Correction

This calculation enables you to use base density to determine the factors for the correction for temperature of the liquid at the meter ( $CTL_m$ ) and the correction for the pressure of the liquid at the meter ( $CPL_m$ ). The system then uses the  $CTL_m$  and  $CPL_m$  values to correct the metered volume to reference conditions.

- Select **Standard Density Correction** from the hierarchy menu. The Standard Density Correction screen displays.

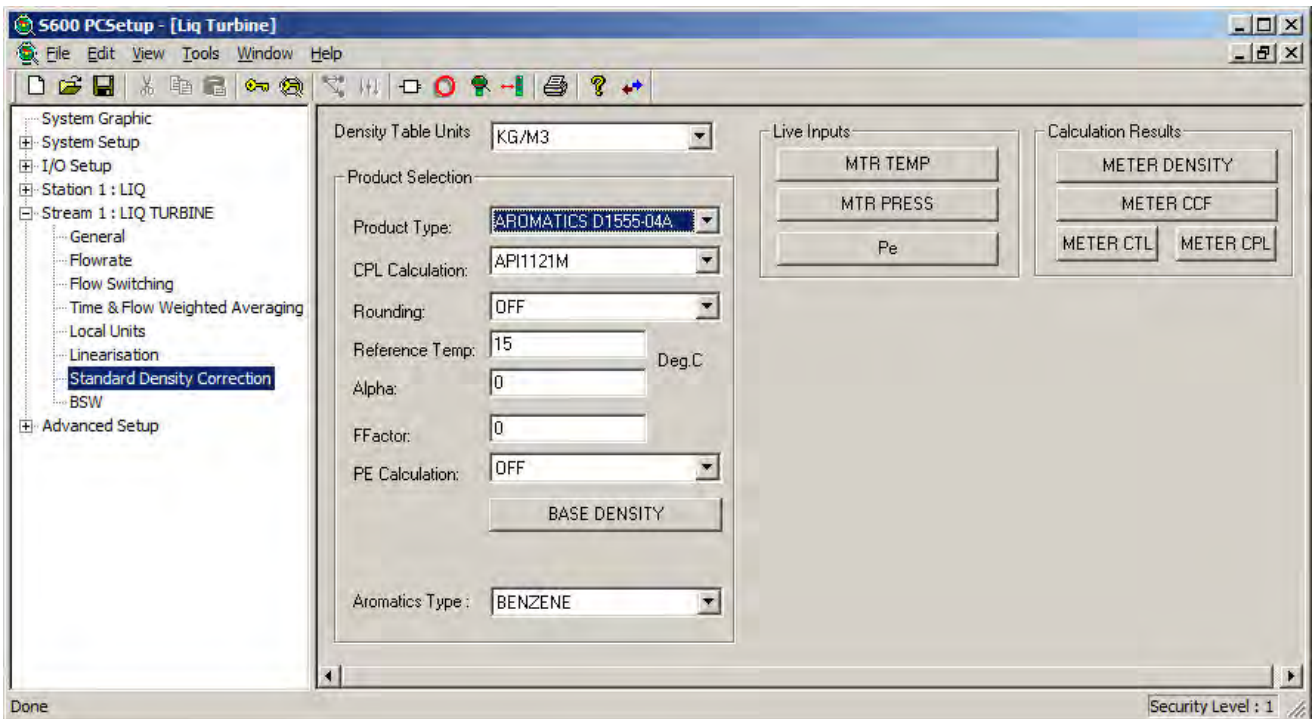

Figure 6-100. Standard Density Correction screen

2. Complete the following fields.

Field	Description
<b>Density Table Units</b>	Indicates the density units the S600+ uses for the density correction calculations. Click ▼ to display all valid values.
<b>CH. 11 2004/7 CUST</b>	Use API MPMS Ch. 11.1 2004, Addendum 1, 2007 Imperial units.
<b>CH. 11 2004/7 METRIC</b>	Use API MPMS Ch. 11.1 2004, Addendum 1, 2007 Metric Units
<b>DEG.API</b>	Use degrees API.
<b>KG/M3</b>	Use kilograms per cubic meter. This is the <b>default</b> .
<b>S.G.</b>	Use specific gravity.
<b>NORSOK I-105</b>	Use Norsok I-105 Appendix D density correction.
	<b>Note:</b> See <i>Table 6-2</i> for product selection.
<b>Product Type</b>	Indicates the type of petroleum product involved in the calculation. Click ▼ to display all valid values. The <b>default</b> is <b>ACRUDE</b> .
<b>A CRUDE</b>	Selection is based on the value in the Density Table Units field: If Density Table Units = KG/M3 and reference temperature = 15 Deg C, Petroleum Measurement Tables 1980 Tables 53A and 54A. If Density Table Units = KG/M3 and reference temperature = 20 Deg C, Petroleum Measurement Tables 1988 Tables 59A and 60A. If SG = Petroleum Measurement Tables 1980 Tables 23A and 24A. If DEG API = Petroleum Measurement Tables 1980 Tables 5A and 6A. If CH.11 2004/7, Cust = API MPMS Chapter 11 2004. If CH.11 2004/7, Metric = API MPMS Chapter 11 2004.
<b>B REFINED</b>	Selection is based on the value in the Density Table Units field: If Density Table Units = KG/M3 and reference temperature = 15 Deg C, Petroleum Measurement Tables 1980 Tables 53B and 54B. If Density Table Units = KG/M3 and reference temperature = 20 Deg C, Petroleum Measurement Tables 1988 Tables 59B and 60B. If SG = Petroleum Measurement Tables 1980 Tables 23B and 24B. If DEG API = Petroleum Measurement Tables 1980 Tables 5B and 6B. If CH.11 2004/7, Cust = API MPMS Chapter 11 2004. If CH.11 2004/7, Metric = API MPMS Chapter 11 2004.

Field	Description
<b>C SPECIAL</b>	<p>Selection is based on the value in the Density Table Units field:</p> <p>If KG/M3 = Petroleum Measurement Tables 1980 Table 54C.</p> <p>If SG = Petroleum Measurement Tables 1980 Tables 23C and 24C.</p> <p>If DEG API = Petroleum Measurement Tables 1980 Tables 5C and 6C.</p> <p>If CH.11 2004/7, Cust = API MPMS Chapter 11 2004.</p> <p>If CH.11 2004/7, Metric = API MPMS Chapter 11 2004.</p> <p><b>Note:</b> Table 53C is not implemented as the assumption is made that the base density is already known. This is because Table 53C allows for a keypad entry of Alpha, and if this is known then the base density would be known.</p>
<b>D LUBE OILS</b>	<p>Selection is based on the value in the Density Table Units field:</p> <p>If Density Table Units = KG/M3 and reference temperature = 15 Deg C, Petroleum Measurement Tables 1982 Tables 53D and 54D.</p> <p>If Density Table Units = KG/M3 and reference temperature = 20 Deg C, Petroleum Measurement Tables 1988 Tables 59D and 60D.</p> <p>If SG =, Petroleum Measurement Tables 1982 Tables 23D and 24D.</p> <p>If DEG API = Petroleum Measurement Tables 1982 Tables 5D and 6D.</p> <p>If CH.11 2004/7, Cust = API MPMS Chapter 11 2004.</p> <p>If CH.11 2004/7, Metric = API MPMS Chapter 11 2004.</p>
<b>LIGHT 1986</b>	<p>ASTM-IP-API Petroleum Measurement Tables for Light Hydrocarbon Liquids 1986 Tables 53 and 54.</p>
<b>ASTM-IP 1952</b>	<p>ASTM-IP Petroleum Measurement Tables 1952 Tables 23, 24, 53 and 54 (Algorithm).</p> <p><b>Note:</b> The output is based on the relevant formula or look up tables dependent on the density input.</p>

Field	Description
<b>TABLE LOOKUP</b>	<p>S600+ reads values from a file in the Config600 3.x/Config/Project Name/extras directory and transfers that data into the S600+ with the configuration file. The specific file selected is based on the value in the Density Table Units field:</p> <p>If <b>SG</b>, values are read from the ASTM-IP Petroleum Measurement Tables 1952 Tables 23 file.</p> <p>If <b>DEG API</b>, values are read from the ASTM-IP Petroleum Measurement Tables 1952 Tables 5 file.</p> <p>For <b>KG/M3</b>, please consult technical support.</p>
<b>USER K0 K1</b>	<p>Selection is based on the value in the Density Table Units field:</p> <p>If KG/M3 = Petroleum Measurement Tables 1980 Tables 53A and 54A with user entered values for K0 and K1.</p> <p>If SG = Petroleum Measurement Tables 1980 Tables 23A and 24A with user entered values for K0 and K1.</p> <p>If DEG API = Petroleum Measurement Tables 1980 Tables 5A and 6A with user entered values for K0 and K1.</p>
<b>LIGHT TP25</b>	GPA TP-25 1998 (API Tables 23E and 24E).
<b>LIGHT TP27</b>	GPA TP-27 2007 (API Tables 23E, 24E, 53E, 54E, 59E and 60E).
<b>AROMATICS D1555M-95</b>	ASTM D1555-95 Table lookup.
<b>AROMATICS D1555M-00</b>	ASTM D1555M-00 Table Lookup.
<b>AROMATICS D1555M-04A</b>	ASTM D1555-04a Calculation.
<b>AROMATICS D1555M-08</b>	ASTM D1555M-08 Calculation.
<b>STO5.9 08 B1 UGC</b>	Gazprom STO-5.9 2008 Addendum B.1 Unstable Gas Condensate.
<b>STO5.9 08 B2 SLH</b>	Gazprom STO-5.9 2008 Addendum B.2 Stable Liquid Hydrocarbon.
<b>STO5.9 08 B3 WFLH</b>	Gazprom STO-5.9 2008 Addendum B.3 Wide Fraction Liquid Hydrocarbon.

Field	Description
<b>CPL Calculation</b>	<p>Indicates the specific CPL calculation the S600+ uses. Click ▼ to display all valid values.</p> <p>Note: This field <b>does not</b> display if you select <b>CH.11 2004 CUST</b> or <b>CH.11 2004 METRIC</b> as the Density Table Units or one of the Gazprom options as Product Type because these standards also specify the CPL calculation.</p>
<b>OFF</b>	No CPL calculation.
<b>API121</b>	Use API MPMS Ch.11.2.1 1984.
<b>API1121M</b>	Use API MPMS Ch. 11.2.1M 1984. This is the <b>default</b> .
<b>API122</b>	Use API MPMS Ch.11.2.2 1986
<b>API122M</b>	Use API MPMS Ch.11.2.2M 1986
<b>CONSTANT</b>	Use a value you enter.
<b>DOWNER</b>	Use calculations specified in L. Downer's 1979 paper <i>Generation of New Compressibility Tables for International Use</i>
<b>Rounding</b>	<p>Indicates whether the S600+ rounds the calculation results. Click ▼ to display all valid values.</p>
<b>OFF</b>	No rounding occurs. This is the <b>default</b> .
<b>NATIVE</b>	Round to the rules specified in the selected calculation standard.
<b>API Ch.12.2 Part 2</b>	Round in accordance with API MPMS Ch. 12.2 Part 2 – Measurement Tickets 1995
<b>API Ch.12.2 Part 3</b>	Round in accordance with API MPMS Ch. 12.2 Part 3 – Proving Reports 1998
<b>Flocheck</b>	Round in accordance with Emerson Flowcheck verification software package
<b>ASTM D1250-04 Ch.11</b>	Round in accordance with API MPMS Ch. 11.1 2004 (ASTM D1250-04) method to round to the Petroleum Measurement Table 1980 Tables
<b>DECC 1980</b>	DTI/DECC requirements for Petroleum Measurement Tables 1980 Tables. No rounding occurs and an iteration tolerance of 0.0001.
<b>Reference Temp</b>	Sets, in degrees Centigrade, the reference temperature for the correction calculations. The default is <b>15</b> degrees C.
<b>Alpha</b>	Sets the coefficient of thermal expansion. The default is <b>0</b> .
<b>FFactor</b>	Sets the compressibility factor for the liquid (also known as the beta factor). The default is <b>0</b> .

Field	Description
<b>PE Calculation</b>	Sets the option to calculate the fluid's Equilibrium Vapour Pressure. While this is normally assumed to be 0, you can use it for natural gas liquids (NGL) and similar applications. Click ▼ to display all valid values.
<b>OFF</b>	Do not calculate PE value. This is the <b>default</b> .
<b>GPA TP-15 1988 Equation 2</b>	Use the GPA TP-15 1988 Equation 2
<b>GPA TP-15 2003 Equation 2</b>	Use the GPA TP-15 2003 Equation 2
<b>GPA TP-15 1988 Equation 3</b>	Use the GPA TP-15 1988 Equation 3
<b>GPA TP-15 2003 Equation 3</b>	Use the GPA TP-15 2003 Equation 3
<b>BASE DENSITY</b>	Click to display a Calculation Result dialog box you use to define the mode, keypad value, and the specific alarm limits for base density. <b>Note:</b> The label on this button changes depending on the configuration.
<b>BASE DENS (DT)</b>	Click to display a Calculation Result dialog box you use to define the mode, keypad value, and the specific alarm limits for base density. <b>Note:</b> This button displays <b>only</b> if you select the density to stream option.
<b>Aromatics Type</b>	Sets the type of aromatics product. Click ▼ to display all valid values. The default is Benzene.

Table 6-4. Standard Density Correction Product Selection

Density Units	Product Type									
	ASTM-IP 1952	A Crude	B Refined	C Special	D Lube Oils	Light 1986	Light TP25	Light TP27	Table Lookup	User K0 K1
<b>DEG API</b>	ASTM D1250 (1952) Table 6	ASTM D1250-80 Table 6A	ASTM D1250-80 Table 6B	ASTM D1250-80 Table 6C	ASTM D1250-80 Table 6D	n/a	n/a	n/a	User lookup table	ASTM D1250-80 Table 6A/ User K0,K1
<b>S.G.</b>	ASTM D1250 (1952) Table 24	ASTM D1250-80 Table 24A	ASTM D1250-80 Table 24B	ASTM D1250-80 Table 24C	ASTM D1250-80 Table 24D	n/a	GPA TP-25/ 1988 Table 24E	GPA TP-27 Table 24E	User lookup table	ASTM D1250-80 Table 24A/ User K0,K1
<b>KG/M3</b>	ASTM D1250 (1952) Table 54	ASTM D1250-80 Table 54A IP Paper 3 (1988) Table 60A (20°C Reference Temp)	ASTM D1250-80 Table 54B IP Paper 3 (1988) Table 60B (20°C Reference Temp)	ASTM D1250-80 Table 54C	ASTM D1250-80 Table 54D IP Paper 3 (1988) Table 60D (20°C Reference Temp)	ASTM-IP-API Petroleum Measurement tables for light hydrocarb on liquids 1986	n/a	GPA TP-27 Table 54E GPA TP-27 Table 60E (20°C Reference Temp)	User lookup table	ASTM D1250-80 Table 54A/ User K0,K1
<b>CH. 11 2004/7 CUST</b>	n/a	ASTM D1250-04	ASTM D1250-04	ASTM D1250-04	ASTM D1250-04	n/a	n/a	n/a	n/a	n/a
<b>CH. 11 2004/7 Metric</b>	n/a	ASTM D1250-04	ASTM D1250-04	ASTM D1250-04	ASTM D1250-04	n/a	n/a	n/a	n/a	n/a
<b>NORSOK I-105</b>	ASTM D1250-04	ASTM D1250-04	ASTM D1250-04	ASTM D1250-04	ASTM D1250-04	ASTM D1250-04	ASTM D1250-04	ASTM D1250-04	ASTM D1250-04	ASTM D1250-04

3. Click any of the following buttons to define **live inputs** for the calculations.



Button	Description
<b>MTR TEMP</b>	Displays a Calculation Result dialog box you use to define the mode, keypad value, and the specific alarm limits for meter temperature. <b>Note:</b> The label on this button changes depending on the configuration.
<b>MTR PRESS</b>	Displays a Calculation Result dialog box you use to define the mode, keypad value, and the specific alarm limits for meter pressure. <b>Note:</b> This button displays only if you select the meter (SEL TO BASE) stream component.
<b>Pe</b>	Displays a Calculation Result dialog box you use to define the mode, keypad value, and the specific alarm limits for equilibrium vapour pressure (Pe). <b>Note:</b> The label on this button changes depending on the configuration.

- Click any of the following buttons to define **calculation results** for the correction calculations.

Button	Description
<b>METER DENSITY</b>	Displays a Calculation Result dialog box you use to define the mode, keypad value, and the specific alarm limits for meter density. <b>Note:</b> The label on this button changes depending on the configuration.
<b>METER CCF</b>	Displays a Calculation Result dialog box you use to define the mode, keypad value, and the specific alarm limits for the combined correction factor at the meter (CCF <sub>m</sub> ). <b>Note:</b> The label on this button changes depending on the configuration.
<b>METER CTL</b>	Displays a Calculation Result dialog box you use to define the mode, keypad value, and the specific alarm limits for the correction of the temperature of the liquid at the meter (CTL <sub>m</sub> ). <b>Note:</b> The label on this button changes depending on the configuration.
<b>METER CPL</b>	Displays a Calculation Result dialog box you use to define the mode, keypad value, and the specific alarm limits for the correction of the pressure of the liquid at the meter (CPL <sub>m</sub> ). <b>Note:</b> The label on this button changes depending on the configuration.

- Click in the hierarchy menu when you finish defining settings. A confirmation dialog box displays.
- Click **Yes** to apply your changes. The PCSetup screen displays.

### 6.8.6 Base Sediment and Water (BSW)

This option provides base sediment and water (BSW) settings for the calculation of the net volume totals.

- Select **BSW** from the hierarchy menu. The BSW screen displays.

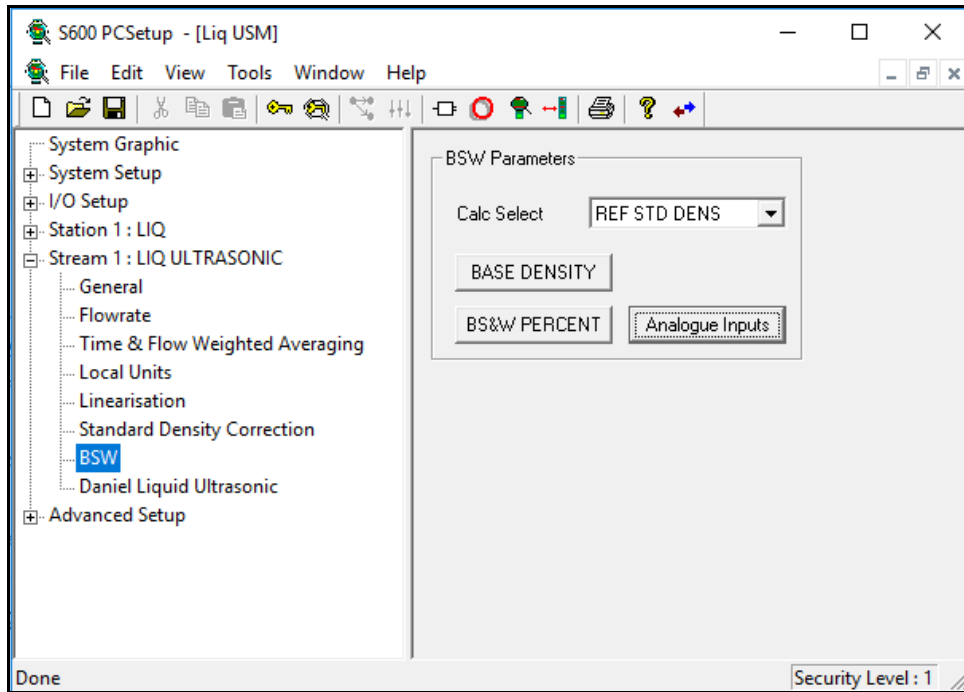

Figure 6-101. BSW screen

8. Complete the following field.

Field	Description
<b>Calc Select</b>	Indicates the standard the S600+ uses for the BSW calculations. Click ▼ to display all valid values.
<b>IP VII/2 4.12</b>	Use IP VII/2 4.12 standard. This is the <b>default</b> .
<b>REF METER DENS</b>	Use the meter density; mass = meter dry volume * meter density
<b>REF STD DENS</b>	Use the standard density; mass = std dry volume * std density.
<b>US METHOD 1</b>	Use the meter density; mass = meter wet volume * meter density.
<b>NORSOK I-105</b>	Use Norsok I-105 Appendix D method of computing totals. This <b>must</b> be used in conjunction with Norsok I-105 Density Table Units option.

9. Click any of the following buttons to define BSW parameters.

Button	Description
<b>BASE DENSITY</b>	Click to display a Calculation Result dialog box you use to define the mode, keypad value, and the specific alarm limits for base density.
<b>BSW PERCENT</b>	Click to display an Analog Input dialog box you use to define various values for the analogue input.
<b>Analogue Inputs</b>	Click to display the I/O Setup screen's settings related to the BSW analog input for the selected stream.

10. Click in the hierarchy menu when you finish defining settings. A confirmation dialog box displays.

11. Click **Yes** to apply your changes. The PCSetup screen displays.

## 6.9 Liquid - Ultrasonic

These stream settings are specific to liquid ultrasonic applications using turbine meters. When you initially create a configuration, the calculation selections you make determine which calculation-specific screens appear in the hierarchy menu.



### Caution

It is extremely unlikely that any one S600+ configuration would contain all the settings discussed in this section. For that reason, several sample configurations demonstrate the settings.

### 6.9.1 Local Units

This option allows you to override the global K-factor unit as a liquid application may have more than one type of meter, each using different K-factor units.

1. Select **Local Units** from the hierarchy menu. The Local Units screen displays.

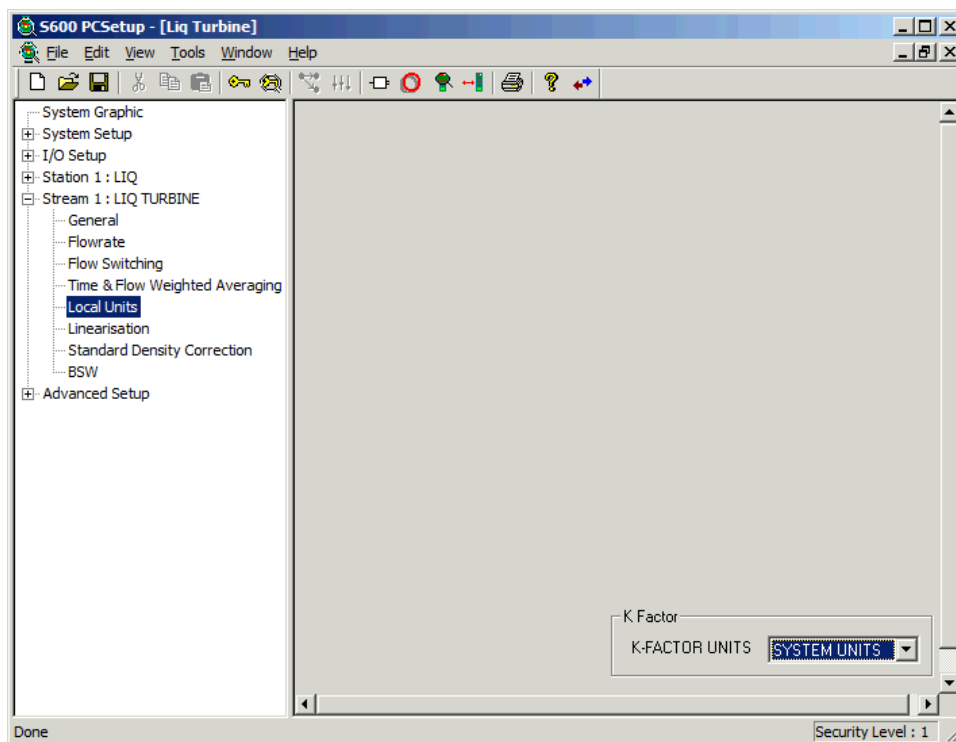

Figure 6-102. Local Units screen

2. Complete the following field.

Field	Description
<b>K-factor Units</b>	Indicates the type of units you desire to use and override the system K-factor units of measurement. Click ▼ to display all valid values. The default is <b>SYSTEM UNITS</b> . <b>Note:</b> If you select <b>System Units</b> , the stream uses the global default value.

3. Click in the hierarchy menu when you finish defining settings. A confirmation dialog box displays.
4. Click **Yes** to apply your changes. The PCSetup screen displays.

## 6.9.2 Sampling

Sampling settings define the method and interval period for sampling product from a flowing pipeline. By default, the S600+ supports one sampler per stream. If you require more than one sampler per stream, contact Technical Support personnel. Config600 uses the following stages during the sampling process:

Stage	Description
<b>0</b>	Idle
<b>1</b>	Monitor
<b>2</b>	Digout n
<b>3</b>	Min Intvl
<b>4</b>	Post Pulse
<b>5</b>	Stopped Manually
<b>6</b>	Stopped Can Full
<b>7</b>	Stopped Low Flow
<b>8</b>	Initial Time
<b>9</b>	Check Flow Switch
<b>10</b>	Stopped Flow Switch
<b>11</b>	Stopped Press Switch
<b>12</b>	Stopped initialise
<b>13</b>	Can Switch Over

---

**Note:** Batch auto-resets the sampler at the start of the batch.

---

5. Select **Sampling** from the hierarchy menu. The Sampling screen displays.

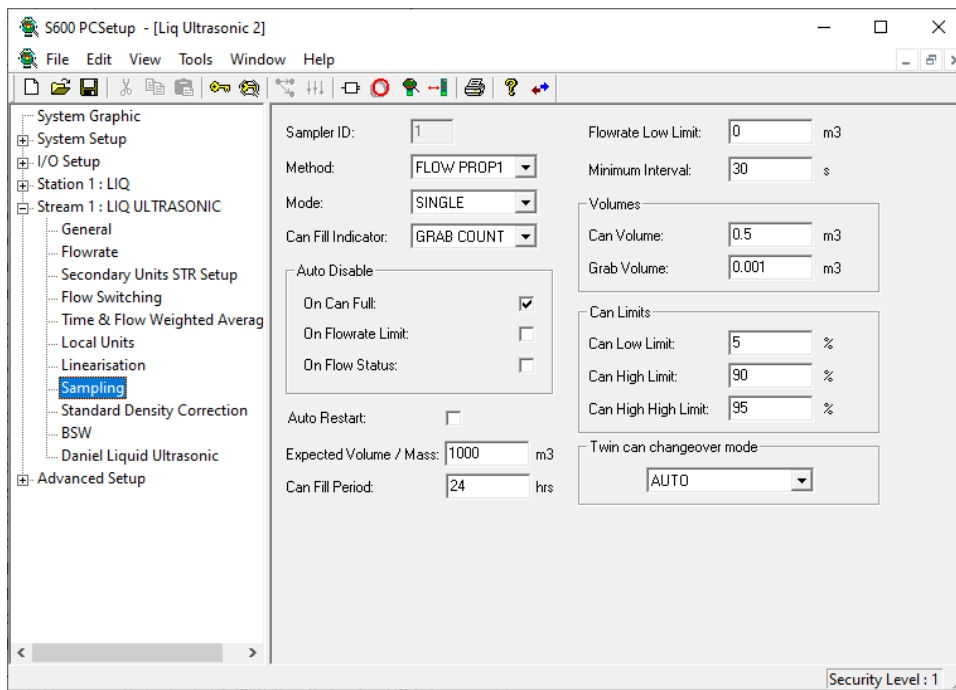

Figure 6-103. Sampling screen

6. Complete the following fields.

Field	Description
<b>Sampler ID</b>	Provides an identifying label for the sampler. Each stream or station must have a unique sampler ID.
<b>Method</b>	Indicates the sampling method. Click ▼ to display all valid values.
<b>TIME PROP</b>	Divides the value in the Can Fill Period field by the number of grabs needed to fill the can (derived from the Can Volume and Fill Volume values) to determine a time interval per pulse. This is the <b>default</b> .
<b>FLOW PROP1</b>	Divides the value in the Volume field by the number of grabs needed to fill the can (derived from the Can Volume and Fill Volume values) to determine a volume throughput per pulse.
<b>FLOW PROP2</b>	Uses the value in the Volume field as the volume throughput per pulse.
<b>FLOW PROP3</b>	Uses the value in the Volume field as the volume throughput per pulse, but supports low pressure digital input and pump prime output.

<b>Field</b>	<b>Description</b>
<b>Mode</b>	Indicates the sampling mode. Click ▼ to display all valid values. The default is <b>SINGLE</b> .
<b>Can Fill Indicator</b>	Indicates how the S600+ determines when the sampling can is full. Click ▼ to display all valid values. The default is <b>GRAB COUNT</b> . <b>GRAB COUNT</b> Uses the number of pulses output during the sample to determine when the can is full. <b>DIG I/P</b> Uses a digital input to determine when the can is full. <b>ANALOG I/P</b> Uses an analog input to determine when the can is full.
<b>Auto Disable</b>	Indicates the event at which the system automatically disables the sampling process. Select the appropriate check box to identify the specific event.
<b>Auto Restart</b>	Indicates whether the system automatically restarts sampling after automatically disabling sampling.
<b>Expected Volume/Mass</b>	Sets the volume or mass of the sampling can. The default is <b>1000</b> .
<b>Can Fill Period</b>	Sets, in hours, the time required to fill the sampling can. The default is <b>24</b> . <b>Note:</b> This field is required for the TIME PROP sampling method.
<b>Flowrate Low Limit</b>	Sets the volume at which automatic disabling occurs. The default is <b>0</b> . <b>Note:</b> This field is required if you select the On Flowrate Limit check box for Auto Disable.
<b>Minimum Interval</b>	Sets the minimum interval, in seconds, for sampling. The default is <b>30</b> . <b>Note:</b> If the sample exceeds this limit, the system sets the overspeed alarm and increments the overspeed counter.
<b>Can Volume</b>	Sets the volume of the sampling can. The default is <b>0.5</b> .
<b>Grab Volume</b>	Sets the volume of each sampling grab. The default is <b>0.001</b> .
<b>Can Low Limit</b>	Sets the low limit alarm as a percentage of the Can Volume. The default is <b>5</b> .
<b>Can High Limit</b>	Sets the high limit alarm as a percentage of the Can Volume. The default is <b>90</b> .
<b>Can High High Limit</b>	Sets the high high alarm as a percentage of the Can Volume. The default is <b>95</b> .
<b>Twin Can Changeover</b>	Indicates the changeover method for twin can sampling. Click ▼ to display all valid values.

Field	Description
<b>AUTO</b>	The sampler automatically changes over to the second can when the first is full.
<b>MANUAL</b>	<p>The sampler pauses sampling when the first can is full and requires the operator to change the value of Can Selected before sampling continues on the second can.</p> <p><b>Note:</b></p> <ul style="list-style-type: none"> <li>▪ If sampling is stopped because both cans are full, the Twin Can Changeover Mode is set to MANUAL by the system. The user must set back to AUTO if required.</li> <li>▪ The display for Twin Can Changeover must be manually added to the displays.</li> </ul>

7. Click in the hierarchy menu when you finish defining settings. A confirmation dialog box displays.
8. Click **Yes** to apply your changes. The PCSetup screen displays.

### 6.9.3 Linearisation

Linearisation settings define the constants and calculation limits for the meter factor and K-factor. The S600+ calculates a meter factor corresponding to the frequency by interpolating the frequency between fixed points and then cross-referencing the result against a lookup table. Linearisation settings also allow you to define alarms. The system activates these alarms when the calculated results for the Meter Factor are not within specified limits.

#### Notes:

- The linearisation curve for Liquid Ultrasonic configurations uses IVOL Flow Rate as the default input for Meter Factor calculations. The ability to change the default is available **only** with Config600 Pro software.
- Batching systems that employ meter factor linearisation with retrospective meter factor adjustments assume that the adjusted value has a "keypad" mode.
- To prevent the live metering system from applying a double correction, use **either** a calculated meter factor **or** a calculated K-factor linearisation (that is, only one factor should have a calculated mode).

1. Select **Linearisation** from the hierarchy menu. The Linearisation screen displays.

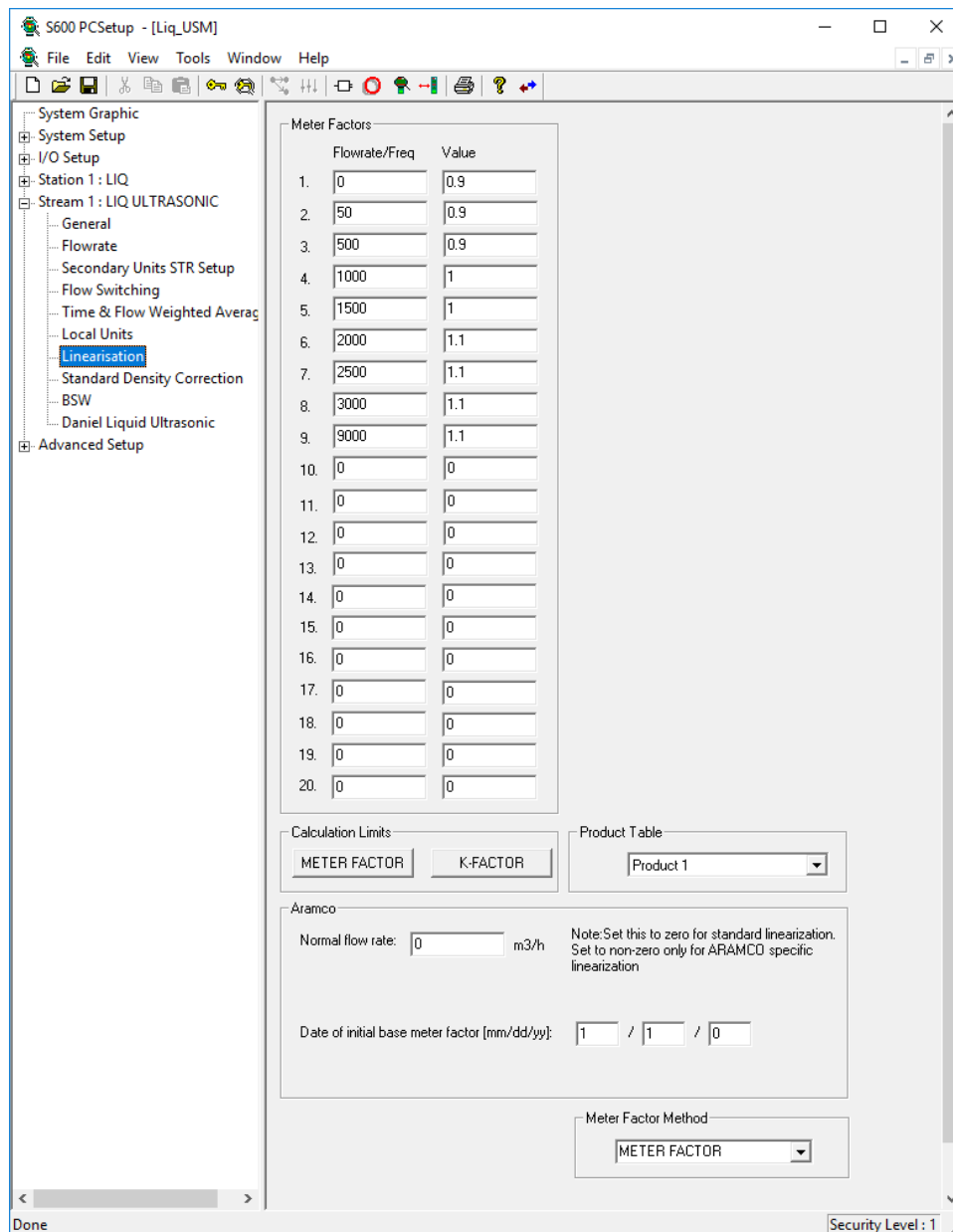

Figure 6-104. Linearisation screen



2. Complete the following fields.

Field	Description
<b>Meter Factors</b>	Sets up to 20 flow rate and values for the meter correction factors.
	<b>Flowrate/Freq</b> Set the flowrate and frequency for each of the meter correction factors.
	<b>Value</b> Set the corresponding values for each of the meter factors.
<b>METER FACTOR</b>	Click to display a Calculation Result dialog box you use to define the mode, keypad value, and the specific alarm limits for the respective factor.
<b>K-FACTOR</b>	Click to display a Calculation Result dialog box you use to define the mode, keypad value, and the specific alarm limits for the respective factor.
<b>Product Table</b>	It allows the selection of the “default” Product Table (the in-use functionality) and the 16 other Product Tables in order to set up to 10 flow rates and values for the meter correction factors and K-factors for each product type. When you select a specific product, the meter factors and K-factors update accordingly. <b>Note:</b> This field displays <b>only</b> if you enable the Product Table when you create the configuration.
<b>Aramco</b>	Aramco-style linearisation is identical to normal linearisation, but is only used to generate the first meter factor – subsequent meter factors are generated from proving. <b>Notes:</b> <ul style="list-style-type: none"> <li>▪ Ignore the fields in the Aramco frame unless directed by technical support.</li> <li>▪ You <b>must</b> select Product Table with History when you create your configuration in order to use the Prover MF Deviation Check stage.</li> </ul>
	<b>Normal Flow Rate</b> Set to zero for standard linearisation. Set to non-zero <b>only</b> for Aramco-style linearisation. <b>Note:</b> For Aramco-style linearisation <b>only</b> , the Initial Meter Factor is calculated from the linearisation curve and the Normal Flow Rate. This Initial Meter Factor is then used in the subsequent proving functionality.
	<b>Date of Initial Base Meter Factor</b> Set the time stamp of the initial base meter factor. <b>Note:</b> This field displays <b>only</b> if you enable the Product Table with History when you create the configuration.
<b>Meter Factor Method</b>	Selectable between METER FACTOR (values entered as normal) and ERROR PERCENT (Meter Factor entered as a percentage).

3. Click in the hierarchy menu when you finish defining settings. A confirmation dialog box displays.

4. Click **Yes** to apply your changes. The PCSetup screen displays.

#### 6.9.4 Observed Density Correction

This option enables you to determine base density from measured density. The system uses base density, coordinated with the standard density correction, to calculate correction values for the temperature of the liquid at the meter ( $CTL_m$ ) and the pressure of the liquid at the meter ( $CPL_m$ ). The system then uses the  $CTL_m$  and  $CPL_m$  values to correct the metered volume to reference conditions.

You can measure density at the header, which is associated with the station because it is a common density available to all streams (OBS TEMP and OBS PRESS), or you can measure it at the meter, which is associated with a specific stream (MTR TEMP and MTR PRESS). If you do not measure density, this screen does not display and you enter a density at standard conditions.

1. Select **Observed Density Correction** from the hierarchy menu. The Observed Density Correction screen displays.

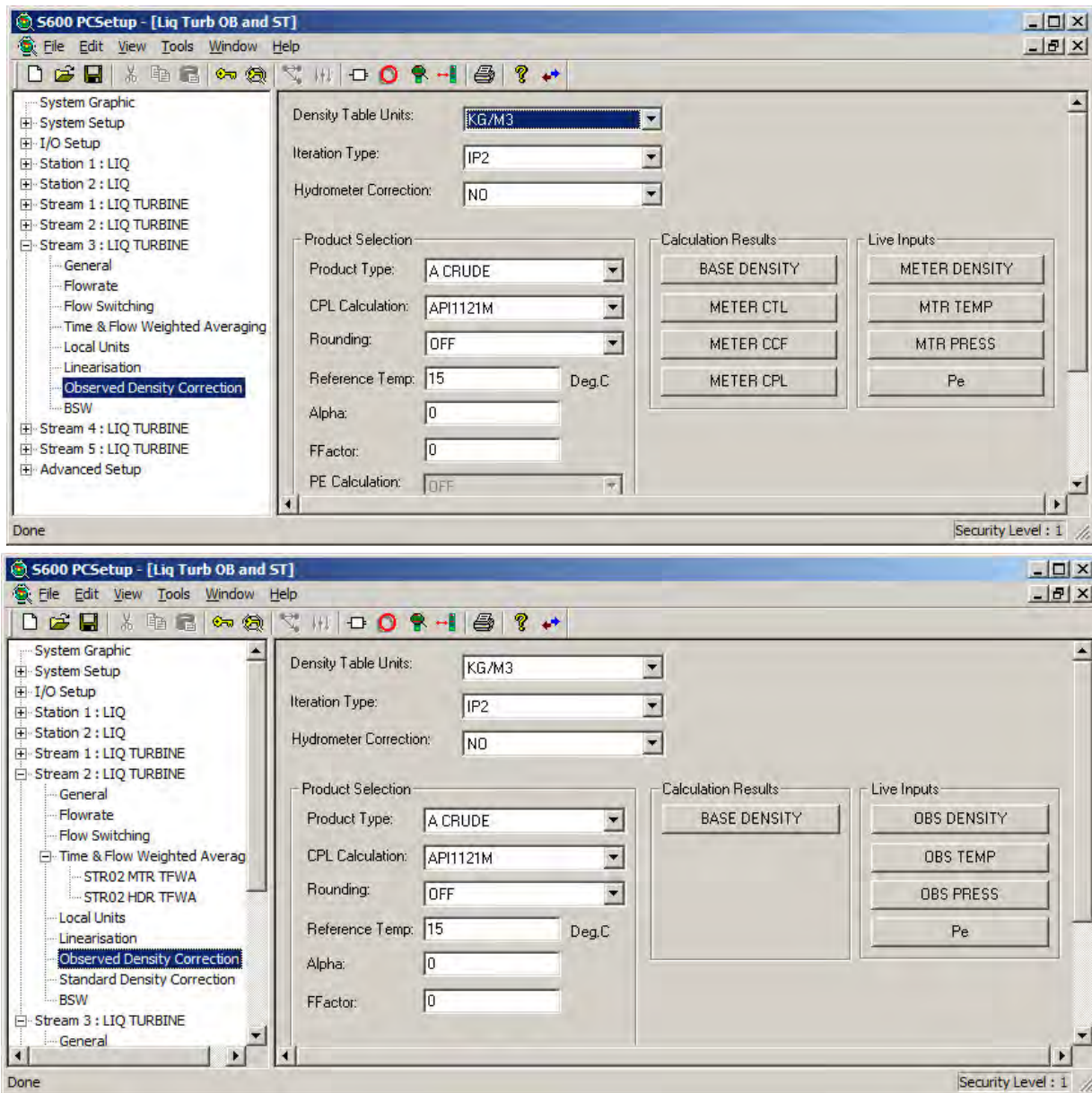

Figure 6-105. Observed Density Correction screen

2. Complete the following fields.

<b>Field</b>	<b>Description</b>
<b>Density Table Units</b>	Indicates the density units the S600+ uses for the density correction calculations. Click ▼ to display all valid values.
	<b>CH. 11 2004/7 CUST</b> Use API MPMS Chapter 11.1 2004, Addendum 1, 2007 Imperial Units.
	<b>CH. 11 2004/7 METRIC</b> Use API MPMS Chapter 11.1 2004, Addendum 1, 2007 Metric Units.
	<b>DEG API</b> Use degrees API.
	<b>KG/M3</b> Use kilograms per cubic meter. This is the <b>default</b> .
	<b>S.G.</b> Use specific gravity.
	<b>NORSOK I-105</b> Use Norsok I-105 Appendix D density correction.
<b>Iteration Type</b>	Indicates the iteration type for the density correction calculations. Valid values are <b>ASTM</b> (use the iterative temperature and pressure correction as defined by ASTM/API, Chapter 12) or <b>IP2</b> (use the iterative temperature and pressure correction as defined in IP 2 [ISO 91-1]). The <b>default</b> is <b>ASTM</b> .
<b>Hydrometer Correction</b>	Indicates whether the S600+ applies hydrometer correction values to the calculation. Valid values are <b>YES</b> and <b>NO</b> ; the default is <b>NO</b> .
<b>Product Type</b>	Indicates the type of petroleum product involved in the calculation. Click ▼ to display all valid values. The <b>default</b> is <b>A CRUDE</b> .
	<b>A CRUDE</b> Selection is based on the value in the Density Table Units field: If Density Table Units = KG/M3 and reference temperature = 15 Deg C, Petroleum Measurement Tables 1980 Tables 53A and 54A. If Density Table Units = KG/M3 and reference temperature = 20 Deg C, Petroleum Measurement Tables 1988 Tables 59A and 60A. If SG =, Petroleum Measurement Tables 1980 Tables 23A and 24A. If DEG API = Petroleum Measurement Tables 1980 Tables 5A and 6A. If CH.11 2004/7, Cust = API MPMS Chapter 11 2004. If CH.11 2004/7, Metric = API MPMS Chapter 11 2004.

Field	Description
<b>B REFINED</b>	<p>Selection is based on the value in the Density Table Units field:</p> <p>If Density Table Units = KG/M3 and reference temperature = 15 Deg C, Petroleum Measurement Tables 1980 Tables 53B and 54B.</p> <p>If Density Table Units = KG/M3 and reference temperature = 20 Deg C, Petroleum Measurement Tables 1988 Tables 59B and 60B.</p> <p>If SG = Petroleum Measurement Tables 1980 Tables 23B and 24B.</p> <p>If DEG API = Petroleum Measurement Tables 1980 Tables 5B and 6B.</p> <p>If CH.11 2004/7, Cust = API MPMS Chapter 11 2004.</p> <p>If CH.11 2004/7, Metric = API MPMS Chapter 11 2004.</p>
<b>C SPECIAL</b>	<p>Selection is based on the value in the Density Table Units field:</p> <p>If KG/M3 = Petroleum Measurement Tables 1980 Table 54C.</p> <p>If SG = Petroleum Measurement Tables 1980 Tables 23C and 24C.</p> <p>If DEG API = Petroleum Measurement Tables 1980 Tables 5C and 6C.</p> <p>If CH.11 2004/7, Cust = API MPMS Chapter 11 2004.</p> <p>If CH.11 2004/7, Metric = API MPMS Chapter 11 2004.</p> <p><b>Note:</b> Table 53C is not implemented as the assumption is made that the base density is already known. This is because Table 53C allows for a keypad entry of Alpha, and if this is known then the base density would be known.</p>

Field	Description
<b>D LUBE OILS</b>	<p>Selection is based on the value in the Density Table Units field:</p> <p>If Density Table Units = KG/M3 and reference temperature = 15 Deg C, Petroleum Measurement Tables 1982 Tables 53D and 54D.</p> <p>If Density Table Units = KG/M3 and reference temperature = 20 Deg C, Petroleum Measurement Tables 1988 Tables 59D and 60D.</p> <p>If SG = Petroleum Measurement Tables 1982 Tables 23D and 24D.</p> <p>If DEG API = Petroleum Measurement Tables 1982 Tables 5D and 6D.</p> <p>If CH.11 2004/7, Cust = API MPMS Chapter 11 2004.</p> <p>If CH.11 2004/7, Metric = API MPMS Chapter 11 2004.</p>
<b>LIGHT 1986</b>	<p>ASTM-IP-API Petroleum Measurement Tables for Light Hydrocarbon Liquids 1986 Tables 53 and 54.</p>
<b>ASTM-IP 1952</b>	<p>ASTM-IP Petroleum Measurement Tables 1952 Tables 23, 24, 53 and 54 (Algorithm).</p> <p><b>Note:</b> The output is based on the relevant formula or look up tables dependent on the density input.</p>
<b>TABLE LOOKUP</b>	<p>S600+ reads values from a file in the Config600 3.x/Config/Project Name/extras directory and transfers that data into the S600+ with the configuration file. The specific file selected is based on the value in the Density Table Units field:</p> <p>If <b>SG</b>, values are read from the ASTM-IP Petroleum Measurement Tables 1952 Tables 23 file.</p> <p>If <b>DEG API</b>, values are read from the ASTM-IP Petroleum Measurement Tables 1952 Tables 5 file.</p> <p>For <b>KG/M3</b>, please consult technical support.</p>
<b>USER K0 K1</b>	<p>Selection is based on the value in the Density Table Units field:</p> <p>If KG/M3 = Petroleum Measurement Tables 1980 Tables 53A and 54A with user entered values for K0 and K1.</p> <p>If SG = Petroleum Measurement Tables 1980 Tables 23A and 24A with user entered values for K0 and K1.</p> <p>If DEG API = Petroleum Measurement Tables 1980 Tables 5A and 6A with user entered values for K0 and K1.</p>

Field	Description
	<b>LIGHT TP25</b> GPA TP-25 1998 (API Tables 23E and 24E).
	<b>LIGHT TP27</b> GPA TP-27 2007 (API Tables 23E, 24E, 53E, 54E, 59E and 60E).
	<b>AROMATICS D1555M-95</b> ASTM D1555-95 Table lookup.
	<b>AROMATICS D1555M-00</b> ASTM D1555M-00 Table Lookup.
	<b>AROMATICS D1555M-04A</b> ASTM D1555-04a Calculation.
	<b>AROMATICS D1555M-08</b> ASTM D1555M-08 Calculation.
	<b>STO5.9 08 B1 UGC</b> Gazprom STO-5.9 2008 Addendum B.1 Unstable Gas Condensate.
	<b>STO5.9 08 B2 SLH</b> Gazprom STO-5.9 2008 Addendum B.2 Stable Liquid Hydrocarbon.
	<b>STO5.9 08 B3 WFLH</b> Gazprom STO-5.9 2008 Addendum B.3 Wide Fraction Liquid Hydrocarbon.
<b>CPL Calculation</b>	Indicates the specific CPL calculation the S600+ uses. Click ▼ to display all valid values. <b>Note:</b> This field <b>does not</b> display if you select <b>CH.11 2004 CUST</b> or <b>CH.11 2004 METRIC</b> as the Density Table Units <b>or</b> one of the Gazprom options as Product Type because these standards also specify the CPL calculation.
	<b>OFF</b> No CPL calculation.
	<b>API121</b> Use API MPMS Ch.11.2.1 1984.
	<b>API1121M</b> Use API MPMS Ch. 11.2.1M 1984. This is the <b>default</b> .
	<b>API122</b> Use API MPMS Ch.11.2.2 1986.
	<b>API122M</b> Use API MPMS Ch.11.2.2M 1986.
	<b>CONSTANT</b> Use a value you enter.
	<b>DOWNER</b> Use calculations specified in L. Downer's 1979 paper <i>Generation of New Compressibility Tables for International Use</i>
<b>Rounding</b>	Indicates whether the S600+ rounds the calculation results. Click ▼ to display all valid values.
	<b>OFF</b> No rounding occurs. This is the <b>default</b> .
	<b>NATIVE</b> Round to the rules specified in the selected calculation standard.
	<b>API Ch.12.2 Part 2</b> Round in accordance with API MPMS Ch. 12.2 Part 2 – Measurement Tickets 1995
	<b>API Ch.12.2 Part 3</b> Round in accordance with API MPMS Ch. 12.2 Part 3 – Proving Reports 1998
	<b>Flocheck</b> Round in accordance with Emerson Flowcheck verification software package
	<b>ASTM D1250-04 Ch.11</b> Round in accordance with API MPMS Ch. 11.1 2004 (ASTM D1250-04) method to round to the Petroleum Measurement Table 1980 Tables

Field	Description
<b>DECC 1980</b>	DTI/DECC requirements for Petroleum Measurement Tables 1980 Tables. No rounding occurs and an iteration tolerance of 0.0001.
<b>Reference Temp</b>	Indicates, in degrees Centigrade, the reference temperature for the correction calculations. The default is <b>15</b> degrees C.
<b>Alpha</b>	Sets the coefficient of thermal expansion. The default is <b>0</b> .
<b>FFactor</b>	Sets the compressibility factor for the liquid (also known as the beta factor). The default is <b>0</b> .
<b>PE Calculation</b>	Sets the option to calculate the fluid's Equilibrium Vapour Pressure. While this is normally assumed to be 0, you can use it for natural gas liquids (NGL) and similar applications. Click ▼ to display all valid values.
<b>OFF</b>	Do not calculate PE value. This is the <b>default</b> .
<b>GPA TP-15 1988 Equation 2</b>	Use the GPA TP-15 1988 Equation 2
<b>GPA TP-15 2003 Equation 2</b>	Use the GPA TP-15 2003 Equation 2
<b>GPA TP-15 1988 Equation 3</b>	Use the GPA TP-15 1988 Equation 3
<b>GPA TP-15 2003 Equation 3</b>	Use the GPA TP-15 2003 Equation 3
<b>Aromatics Type</b>	Sets the type of aromatics product. Click ▼ to display all valid values. The default is <b>Benzene</b> .
<b>Aromatics CCF</b>	Sets the method for calculating a combined corrector factory (CCF) for aromatics products. Valid values are <b>Density</b> (calculate using a density you enter) or <b>Table 1</b> (calculate use a density from an embedded table).

Table 6-5. Observed Density Correction Product Selection

Density Units	Product Type									
	ASTM/IP 1952	A Crude	B Refined	C Special	D Lube Oils	Light 1986	Light TP25	Light TP27	Table Lookup	User K0 K1
<b>DEG API</b>	ASTM D1250 (1952) Table 5 Algorithm	ASTM D1250-80 Table 5A	ASTM D1250-80 Table 5B	n/a	ASTM D1250-80 Table 5D	n/a	n/a	n/a	User lookup table	ASTM D1250-80 Table 5A/ User K0, K1
<b>S.G.</b>	ASTM D1250 (1952) Table 23 Algorithm	ASTM D1250-80 Table 23A	ASTM D1250-80 Table 23B	n/a	ASTM D1250-80 Table 23D	n/a	GPA TP-25/ 1988 Table 23E	GPA TP-27 Table 23E	User lookup table	ASTM D1250-80 Table 23A/ User K0, K1
<b>KG/M3</b>	ASTM D1250 (1952) Table 53 Algorithm	ASTM D1250-80 Table 53A IP Paper 3 (1988) Table 59A (20°C Reference Temp)	ASTM D1250-80 Table 53B IP Paper 3 (1988) Table 59B (20°C Reference Temp)	n/a	ASTM D1250-80 Table 53D IP Paper 3 (1988) Table 59D (20°C Reference Temp)	ASTM-IP- API Petroleum Measurement tables for light hydrocarb on liquids 1986	n/a	GPA TP-27 Table 53E GPA TP-27 Table 59E (20°C Reference Temp)	User lookup table	ASTM D1250-80 Table 53A/ User K0, K1
<b>CH. 11 2004/7 CUST</b>	n/a	ASTM D1250-04	ASTM D1250-04	ASTM D1250-04	ASTM D1250-04	n/a	n/a	n/a	n/a	n/a
<b>CH. 11 2004/7 METRIC</b>	n/a	ASTM D1250-04	ASTM D1250-04	ASTM D1250-04	ASTM D1250-04	n/a	n/a	n/a	n/a	n/a
<b>NORSOK I-105</b>	ASTM D1250-04	ASTM D1250-04	ASTM D1250-04	ASTM D1250-04	ASTM D1250-04	ASTM D1250-04	ASTM D1250-04	ASTM D1250-04	ASTM D1250-04	ASTM D1250-04



3. Click any of the following buttons to define calculation results for the observed density correction calculations.

Button	Description
<b>BASE DENSITY</b>	Displays a Calculation Result dialog box you use to define the mode, keypad value, and the specific alarm limits for base density. <b>Note:</b> The label on this button changes depending on the configuration.
<b>METER CTL</b>	Displays a Calculation Result dialog box you use to define the mode, keypad value, and the specific alarm limits for the correction of the temperature of the liquid at the meter (CTL <sub>m</sub> ). <b>Note:</b> The label on this button changes depending on the configuration.
<b>METER CCF</b>	Displays a Calculation Result dialog box you use to define the mode, keypad value, and the specific alarm limits for the combined correction factor at the meter (CCF <sub>m</sub> ). <b>Note:</b> The label on this button changes depending on the configuration.
<b>METER CPL</b>	Displays a Calculation Result dialog box you use to define the mode, keypad value, and the specific alarm limits for the correction of the pressure of the liquid at the meter (CPL <sub>m</sub> ). <b>Note:</b> The label on this button changes depending on the configuration.

4. Click any of the following buttons to define live inputs for the observed density correction calculations.

Button	Description
<b>METER DENSITY</b>	Displays a Calculation Result dialog box you use to define the mode, keypad value, and the specific alarm limits for meter density. <b>Note:</b> The label on this button changes depending on the configuration.
<b>OBS DENS</b>	Displays a Calculation Result dialog box you use to define the mode, keypad value, and the specific alarm limits for observed density. <b>Note:</b> The label on this button changes depending on the configuration.
<b>MTR TEMP</b>	Displays a Calculation Result dialog box you use to define the mode, keypad value, and the specific alarm limits for meter temperature. <b>Note:</b> The label on this button changes depending on the configuration.
<b>OBS TEMP</b>	Displays a Calculation Result dialog box you use to define the mode, keypad value, and the specific alarm limits for observed temperature. <b>Note:</b> The label on this button changes depending on the configuration.
<b>MTR PRESS</b>	Displays a Calculation Result dialog box you use to define the mode, keypad value, and the specific alarm limits for meter pressure. <b>Note:</b> The label on this button changes depending on the configuration.

Button	Description
<b>OBS PRESS</b>	Displays a Calculation Result dialog box you use to define the mode, keypad value, and the specific alarm limits for observed pressure. <b>Note:</b> The label on this button changes depending on the configuration.
<b>Pe</b>	Displays a Calculation Result dialog box you use to define the mode, keypad value, and the specific alarm limits for observed equilibrium vapour pressure (Pe). <b>Note:</b> The label on this button changes depending on the configuration.

- Click in the hierarchy menu when you finish defining settings. A confirmation dialog box displays.
- Click **Yes** to apply your changes. The PCSetup screen displays.

### 6.9.5 Standard Density Correction

This calculation enables you to use base density to determine the factors for the correction for temperature of the liquid at the meter ( $CTL_m$ ) and the correction for the pressure of the liquid at the meter ( $CPL_m$ ). The system then uses the  $CTL_m$  and  $CPL_m$  values to correct the metered volume to reference conditions.

- Select **Standard Density Correction** from the hierarchy menu. The Standard Density Correction screen displays.

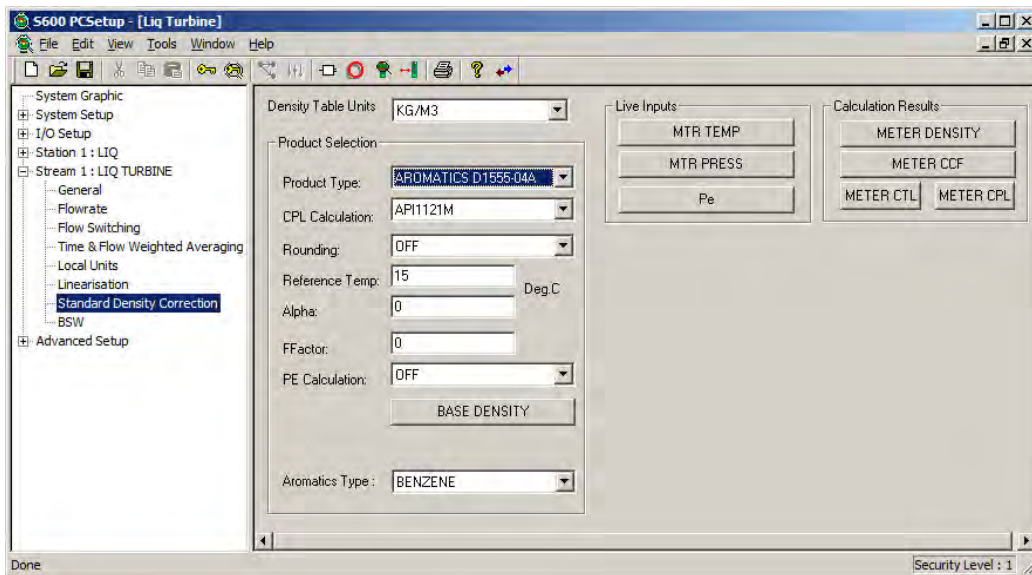

Figure 6-106. Standard Density Correction screen

- Complete the following fields.

Field	Description
<b>Density Table Units</b>	Indicates the density units the S600+ uses for the density correction calculations. Click ▼ to display all valid values.
<b>CH. 11 2004/7 CUST</b>	Use API MPMS Ch. 11.1 2004, Addendum 1, 2007 Imperial units.
<b>CH. 11 2004/7</b>	Use API MPMS Ch. 11.1 2004,

Field	Description
	<b>METRIC</b> Addendum 1, 2007 Metric Units
	<b>DEG.API</b> Use degrees API.
	<b>KG/M3</b> Use kilograms per cubic meter. This is the <b>default</b> .
	<b>S.G.</b> Use specific gravity.
	<b>NORSOK I-105</b> Use Norsok I-105 Appendix D density correction.
	<b>Note:</b> See <i>Table 6-2</i> for product selection.
<b>Product Type</b>	Indicates the type of petroleum product involved in the calculation. Click ▼ to display all valid values. The default is <b>A Crude</b> .
	<p><b>A CRUDE</b> Selection is based on the value in the Density Table Units field:</p> <p>If Density Table Units = KG/M3 and reference temperature = 15 Deg C, Petroleum Measurement Tables 1980 Tables 53A and 54A.</p> <p>If Density Table Units = KG/M3 and reference temperature = 20 Deg C, Petroleum Measurement Tables 1988 Tables 59A and 60A.</p> <p>If SG = Petroleum Measurement Tables 1980 Tables 23A and 24A.</p> <p>If DEG API = Petroleum Measurement Tables 1980 Tables 5A and 6A.</p> <p>If CH.11 2004/7, Cust Density Table Units = API MPMS Chapter 11 2004.</p> <p>If CH.11 2004/7, Metric = API MPMS Chapter 11 2004.</p>
	<p><b>B REFINED</b> Selection is based on the value in the Density Table Units field:</p> <p>If Density Table Units = KG/M3 and reference temperature = 15 Deg C, Petroleum Measurement Tables 1980 Tables 53B and 54B.</p> <p>If Density Table Units = KG/M3 and reference temperature = 20 Deg C, Petroleum Measurement Tables 1988 Tables 59B and 60B.</p> <p>If SG = Petroleum Measurement Tables 1980 Tables 23B and 24B.</p> <p>If DEG API = Petroleum Measurement Tables 1980 Tables 5B and 6B.</p> <p>If CH.11 2004/7, Cust = API MPMS Chapter 11 2004.</p> <p>If CH.11 2004/7, Metric = API MPMS Chapter 11 2004.</p>

Field	Description
<b>C SPECIAL</b>	<p>Selection is based on the value in the Density Table Units field:</p> <p>If KG/M3 = Petroleum Measurement Tables 1980 Table 54C.</p> <p>If SG = Petroleum Measurement Tables 1980 Tables 23C and 24C.</p> <p>If DEG API = Petroleum Measurement Tables 1980 Tables 5C and 6C.</p> <p>If CH.11 2004/7, Cust = API MPMS Chapter 11 2004.</p> <p>If CH.11 2004/7, Metric = API MPMS Chapter 11 2004.</p> <p><b>Note:</b> Table 53C is not implemented as the assumption is made that the base density is already known. This is because Table 53C allows for a keypad entry of Alpha, and if this is known then the base density would be known.</p>
<b>D LUBE OILS</b>	<p>Selection is based on the value in the Density Table Units field:</p> <p>If Density Table Units = KG/M3 and reference temperature = 15 Deg C, Petroleum Measurement Tables 1982 Tables 53D and 54D.</p> <p>If Density Table Units = KG/M3 and reference temperature = 20 Deg C, Petroleum Measurement Tables 1988 Tables 59D and 60D.</p> <p>If SG = Petroleum Measurement Tables 1982 Tables 23D and 24D.</p> <p>If DEG API = Petroleum Measurement Tables 1982 Tables 5D and 6D.</p> <p>If CH.11 2004/7, Cust = API MPMS Chapter 11 2004.</p> <p>If CH.11 2004/7, Metric = API MPMS Chapter 11 2004.</p>
<b>LIGHT 1986</b>	<p>ASTM-IP-API Petroleum Measurement Tables for Light Hydrocarbon Liquids 1986 Tables 53 and 54.</p>
<b>ASTM-IP 1952</b>	<p>ASTM-IP Petroleum Measurement Tables 1952 Tables 23, 24, 53 and 54 (Algorithm).</p> <p><b>Note:</b> The output is based on the relevant formula or look up tables dependent on the density input.</p>

Field	Description
<b>TABLE LOOKUP</b>	<p>S600+ reads values from a file in the Config600 3.x/Config/Project Name/extras directory and transfers that data into the S600+ with the configuration file. The specific file selected is based on the value in the Density Table Units field:</p> <p>If <b>SG</b>, values are read from the ASTM-IP Petroleum Measurement Tables 1952 Tables 23 file.</p> <p>If <b>DEG API</b>, values are read from the ASTM-IP Petroleum Measurement Tables 1952 Tables 5 file.</p> <p>For <b>KG/M3</b>, please consult technical support.</p>
<b>USER K0 K1</b>	<p>Selection is based on the value in the Density Table Units field:</p> <p>If KG/M3 = Petroleum Measurement Tables 1980 Tables 53A and 54A with user entered values for K0 and K1.</p> <p>If SG = Petroleum Measurement Tables 1980 Tables 23A and 24A with user entered values for K0 and K1.</p> <p>If DEG API = Petroleum Measurement Tables 1980 Tables 5A and 6A with user entered values for K0 and K1.</p>
<b>LIGHT TP25</b>	GPA TP-25 1998 (API Tables 23E and 24E).
<b>LIGHT TP27</b>	GPA TP-27 2007 (API Tables 23E, 24E, 53E, 54E, 59E and 60E).
<b>AROMATIC S D1555M-95</b>	ASTM D1555-95 Table lookup.
<b>AROMATIC S D1555M-00</b>	ASTM D1555M-00 Table Lookup.
<b>AROMATIC S D1555M-04A</b>	ASTM D1555-04a Calculation.
<b>AROMATIC S D1555M-08</b>	ASTM D1555M-08 Calculation.
<b>STO5.9 08 B1 UGC</b>	Gazprom STO-5.9 2008 Addendum B.1 Unstable Gas Condensate.
<b>STO5.9 08 B2 SLH</b>	Gazprom STO-5.9 2008 Addendum B.2 Stable Liquid Hydrocarbon.
<b>STO5.9 08 B3 WFLH</b>	Gazprom STO-5.9 2008 Addendum B.3 Wide Fraction Liquid Hydrocarbon.

Field	Description
<b>CPL Calculation</b>	<p>Indicates the specific CPL calculation the S600+ uses. Click ▼ to display all valid values.</p> <p>Note: This field <b>does not</b> display if you select <b>CH.11 2004 CUST</b> or <b>CH.11 2004 METRIC</b> as the Density Table Units or one of the Gazprom options as Product Type because these standards also specify the CPL calculation.</p>
<b>OFF</b>	No CPL calculation.
<b>API121</b>	Use API MPMS Ch.11.2.1 1984.
<b>API1121M</b>	Use API MPMS Ch. 11.2.1M 1984. This is the <b>default</b> .
<b>API122</b>	Use API MPMS Ch.11.2.2 1986.
<b>API122M</b>	Use API MPMS Ch.11.2.2M 1986.
<b>CONSTANT</b>	Use a value you enter.
<b>DOWNER</b>	Use calculations specified in L. Downer's 1979 paper <i>Generation of New Compressibility Tables for International Use</i>
<b>Rounding</b>	<p>Indicates whether the S600+ rounds the calculation results. Click ▼ to display all valid values.</p>
<b>OFF</b>	No rounding occurs. This is the <b>default</b> .
<b>NATIVE</b>	Round to the rules specified in the selected calculation standard.
<b>API Ch.12.2 Part 2</b>	Round in accordance with API MPMS Ch. 12.2 Part 2 – Measurement Tickets 1995.
<b>API Ch.12.2 Part 3</b>	Round in accordance with API MPMS Ch. 12.2 Part 3 – Proving Reports 1998.
<b>Flocheck1</b>	Round in accordance with Emerson Flocheck verification software package .
<b>ASTM D1250-04 Ch.11</b>	Round in accordance with API MPMS Ch. 11.1 2004 (ASTM D1250-04) method to round to the Petroleum Measurement Table 1980 Tables.
<b>DECC 1980</b>	DTI/DECC requirements for Petroleum Measurement Tables 1980 Tables. No rounding occurs and an iteration tolerance of 0.0001.
<b>Reference Temp</b>	Sets, in degrees Centigrade, the reference temperature for the correction calculations. The default is <b>15</b> degrees C.
<b>Alpha</b>	Sets the coefficient of thermal expansion. The default is <b>0</b> .
<b>FFactor</b>	Sets the compressibility factor for the liquid (also known as the beta factor). The default is <b>0</b> .
<b>PE Calculation</b>	<p>Sets the option to calculate the fluid's Equilibrium Vapour Pressure. While this is normally assumed to be 0, you can use it for natural gas liquids (NGL) and similar applications. Click ▼ to display all valid values.</p>
<b>OFF</b>	Do not calculate PE value. This is the <b>default</b> .
<b>GPA TP-15 1988 Equation 2</b>	Use the GPA TP-15 1988 Equation 2.

Field	Description
<b>GPA TP-15 2003 Equation 2</b>	Use the GPA TP-15 2003 Equation 2.
<b>GPA TP-15 1988 Equation 3</b>	Use the GPA TP-15 1988 Equation 3.
<b>GPA TP-15 2003 Equation 3</b>	Use the GPA TP-15 2003 Equation 3.
<b>BASE DENSITY</b>	Click to display a Calculation Result dialog box you use to define the mode, keypad value, and the specific alarm limits for base density. <b>Note:</b> The label on this button changes depending on the configuration.
<b>BASE DENS (DT)</b>	Click to display a Calculation Result dialog box you use to define the mode, keypad value, and the specific alarm limits for base density. <b>Note:</b> This button displays <b>only</b> if you select the density to stream option.
<b>Aromatics Type</b>	Sets the type of aromatics product. Click ▼ to display all valid values. The default is <b>Benzene</b> .
<b>Aromatics CCF</b>	Sets the method for calculating a combined corrector factory (CCF) for aromatics products. Valid values are <b>Density</b> (calculate using a density you enter) or <b>Table 1</b> (calculate use a density from an embedded table).

Table 6-6. Standard Density Correction Product Selection

Density Units	Product Type									
	ASTM/IP 1952	A Crude	B Refined	C Special	D Lube Oils	Light 1986	Light TP25	Light TP27	Table Lookup	User K0 K1
<b>DEG API</b>	ASTM D1250 (1952) Table 6	ASTM D1250-80 Table 6A	ASTM D1250-80 Table 6B	ASTM D1250-80 Table 6C	ASTM D1250-80 Table 6D	n/a	n/a	n/a	User lookup table	ASTM D1250-80 Table 6A/ User K0, K1
<b>S.G.</b>	ASTM D1250 (1952) Table 24	ASTM D1250-80 Table 24A	ASTM D1250-80 Table 24B	ASTM D1250-80 Table 24C	ASTM D1250-80 Table 24D	n/a	GPA TP-25/ 1988 Table 24E	GPA TP-27 Table 24E	User lookup table	ASTM D1250-80 Table 24A/ User K0, K1
<b>KG/M3</b>	ASTM D1250 (1952) Table 54	ASTM D1250-80 Table 54A IP Paper 3 (1988) Table 60A (20°C Reference Temp)	ASTM D1250-80 Table 54B IP Paper 3 (1988) Table 60B (20°C Reference Temp)	ASTM D1250-80 Table 54C	ASTM D1250-80 Table 54D IP Paper 3 (1988) Table 60D (20°C Reference Temp)	ASTM-IP-API Petroleum Measurement tables for light hydrocarb on liquids 1986	n/a	GPA TP-27 Table 54E GPA TP-27 Table 60E (20°C Reference Temp)	User lookup table	ASTM D1250-80 Table 54A/ User K0, K1
<b>CH. 11 2004/7 CUST</b>	n/a	ASTM D1250-04	ASTM D1250-04	ASTM D1250-04	ASTM D1250-04	n/a	n/a	n/a	n/a	n/a
<b>CH. 11 2004/7 Metric</b>	n/a	ASTM D1250-04	ASTM D1250-04	ASTM D1250-04	ASTM D1250-04	n/a	n/a	n/a	n/a	n/a
<b>NORSOK I-105</b>	ASTM D1250-04	ASTM D1250-04	ASTM D1250-04	ASTM D1250-04	ASTM D1250-04	ASTM D1250-04	ASTM D1250-04	ASTM D1250-04	ASTM D1250-04	ASTM D1250-04

3. Click any of the following buttons to define **live inputs** for the standard density correction calculations.

Button	Description
<b>MTR TEMP</b>	Displays a Calculation Result dialog box you use to define the mode, keypad value, and the specific alarm limits for meter temperature. <b>Note:</b> This button displays <b>only</b> if you select the meter (SEL TO BASE) stream component.

Button	Description
<b>MTR PRESS</b>	Displays a Calculation Result dialog box you use to define the mode, keypad value, and the specific alarm limits for meter pressure. <b>Note:</b> This button displays <b>only</b> if you select the meter (SEL TO BASE) stream component.
<b>Pe</b>	Displays a Calculation Result dialog box you use to define the mode, keypad value, and the specific alarm limits for observed equilibrium vapour pressure (Pe). <b>Note:</b> This button displays only if you select the meter (SEL TO BASE) stream component.

- Click any of the following buttons to define **calculation results** for the standard density correction calculations.

Button	Description
<b>METER DENSITY</b>	Click to display a Calculation Result dialog box you use to define the mode, keypad value, and the specific alarm limits for meter density. <b>Note:</b> The label on this button changes depending on whether you select the <b>DT TO BASE</b> or <b>SEL TO BASE</b> stream component.
<b>METER CCF</b>	Click to display a Calculation Result dialog box you use to define the mode, keypad value, and the specific alarm limits for the combined correction factor at the meter (CCF <sub>m</sub> ). <b>Note:</b> This button displays <b>only</b> if you select the SEL TO BASE stream component.
<b>METER CTL</b>	Displays a Calculation Result dialog box you use to define the mode, keypad value, and the specific alarm limits for the correction of the temperature of the liquid at the meter (CTL <sub>m</sub> ). <b>Note:</b> This button displays <b>only</b> if you select the SEL TO BASE stream component.
<b>METER CPL</b>	Displays a Calculation Result dialog box you use to define the mode, keypad value, and the specific alarm limits for the correction of the pressure of the liquid at the meter (CPL <sub>m</sub> ). <b>Note:</b> This button displays <b>only</b> if you select the SEL TO BASE stream component.

- Click in the hierarchy menu when you finish defining settings. A confirmation dialog box displays.
- Click **Yes** to apply your changes. The PCSetup screen displays.

### 6.9.6 Base Sediment and Water (BSW)

This option provides base sediment and water (BSW) settings for the calculation of the net volume totals.

- Select **BSW** from the hierarchy menu. The BSW screen displays.



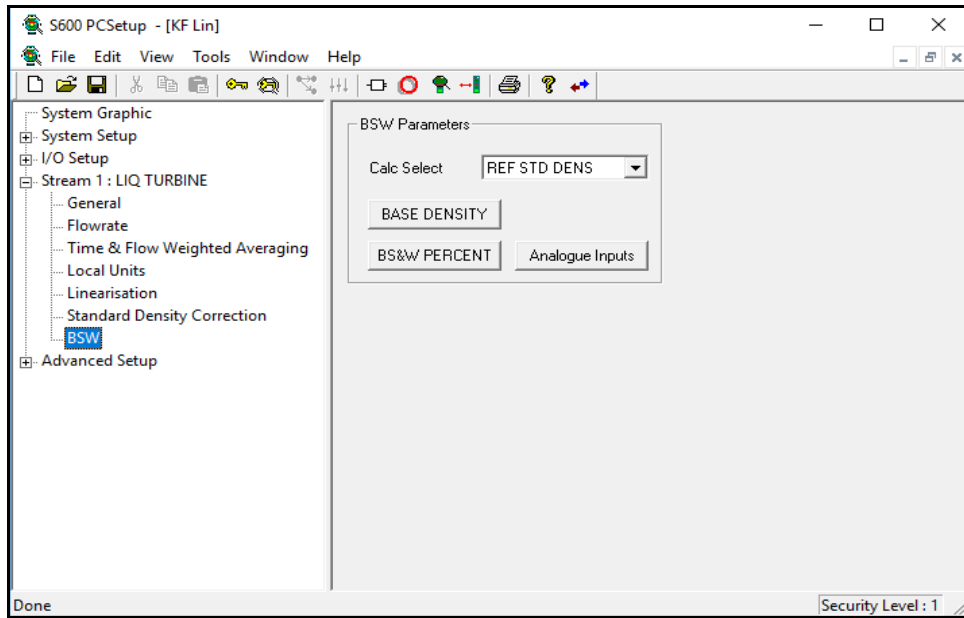

Figure 6-107. BSW screen

2. Complete the following fields

Field	Description
<b>Calc Select</b>	Indicates the standard the S600+ uses for the BSW calculations. Click ▼ to display all valid values.
<b>IP VII/2 4.12</b>	Use IP VII/2 4.12 standard. This is the <b>default</b> .
<b>REF METER DENS</b>	Use the meter density; mass = meter dry volume * meter density
<b>REF STD DENS</b>	Use the standard density; mass = std dry volume * std density.
<b>US METHOD 1</b>	Use the meter density; mass = meter wet volume * meter density.
<b>NORSOK I-105</b>	Use Norsok I-105 Appendix D method of computing totals. This <b>must</b> be used in conjunction with the Norsok I-105 Density Table Units option.

3. Click any of the following buttons to define BSW parameters.

Button	Description
<b>BASE DENSITY</b>	Click to display a Calculation Result dialog box you use to define the mode, keypad value, and the specific alarm limits for base density.
<b>BSW PERCENT</b>	Click to display an Analogue Input dialog box you use to define various values for the analogue input.
<b>Analogue Inputs</b>	Click to display the I/O Setup screen's settings related to the BSW analogue input for the selected stream.

4. Click in the hierarchy menu when you finish defining settings. A confirmation dialog box displays.

5. Click **Yes** to apply your changes. The PCSetup screen displays.

## 6.9.7 Daniel Liquid Ultrasonic

This option provides an interface between the Modbus comms and the generic ultrasonic increments handling.

The S600+ can generate a totals increment from:

- Forward or reverse totals from the ultrasonic meter (USM), corrected for spool housing effects by the ultrasonic meter using temperature and pressure input to the ultrasonic meter.
- Forward or reverse raw totals not corrected for the spool housing at the USM, but corrected in this task using temperature and pressure measurements input directly to the S600+.
- Flowrate calculated by this task from the fluid velocity using the selected temperature and pressure.
- Pulses input from the USM. If there is a good comms link, this task produces CTS and CPS values you can use to correct the flow the pulse input generates.

The flowrate read from the USM corresponds to the totals, corrected at the USM or corrected at the S600+, and can be positive or negative. The flowrate output from this task is always positive and a separate object indicates direction. Flow direction for the velocity option is read from the USM flow direction object.

1. Select **Daniel Liquid Ultrasonic** from the hierarchy menu. The Daniel Liquid Ultrasonic screen displays.

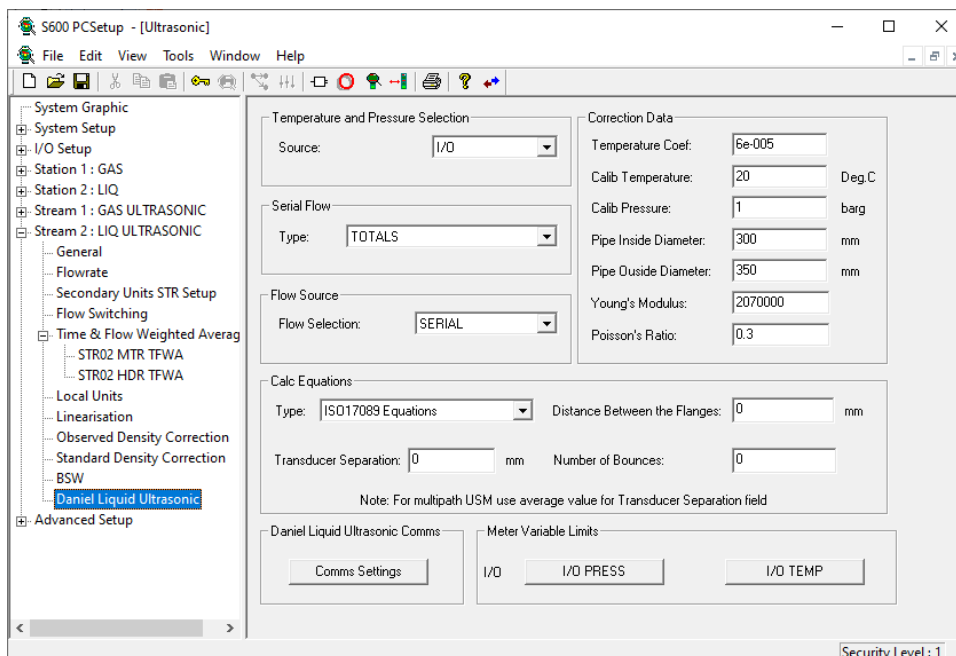

Figure 6-108. Daniel Liquid Ultrasonic screen

2. Complete the following fields.

Field	Description
<b>Source</b>	Indicates whether the temperature and pressure inputs are wired to the USM or to the S600+ I/O. Click ▼ to display all valid values.
<b>USONIC</b>	Use USM as the source for the pressure and temperature. This is the <b>default</b> .

Field	Description
	<p><b>I/O</b> Use S600+ inputs as the source for the pressure and temperature.</p> <hr/> <p><b>Note:</b> If you do not connect temperature and pressure to the USM, disable the pressure and temperature expansion correction (CTSm/CPSm) at the USM.</p> <p>The system assumes that if pressure and temperature are from the <b>USM</b>, the task polls for the <b>corrected</b> flowrate and totals, and if pressure and temperature are from the <b>S600+</b> the task polls for <b>uncorrected</b> flowrate and totals and applies its own CTS and CPS correction.</p> <p>If you acquire the pressure and temperature from the S600+ and you do not assign the analogues, then the system uses the corrected totals from the USM, such as it assumes that if you do not assign S600+ I/O they must connect to the USM and are read from USM.</p> <p>If you configure only temperature or pressure (not both), the system assumes that the non-configured value is read from the USM and the correction is done by the S600+ based on the combination of S600+ and serial data.</p>
<b>Serial Flow Type</b>	<p>Sets the method for generating S600+ totals if you select <b>Serial</b> as the Flow Selection option. .</p> <hr/> <p><b>TOTALS</b> Calculate S600+ totals from the USM totals. This is the <b>default</b>.</p> <p><b>Note:</b> The totals format is from Daniel Series 3800 Liquid Ultrasonic Flow Meter Appendix B.8 Oct 2006.</p> <hr/> <p><b>VELOCITY</b> Calculate S600+ flow rate and totals from the USM velocity</p>
<b>Flow Source</b>	<p>Indicates the source for generating flow totals.</p> <hr/> <p><b>SERIAL</b> Use the serial comms link. This is the <b>default</b>.</p> <hr/> <p><b>PULSE I/P</b> Use the pulse input.</p> <hr/> <p><b>SERIAL + PULSE I/P</b> Use the serial communications link as default and switch to the pulse input if a fault is detected.</p> <p><b>Note:</b> This option requires both a serial interface and pulse input to be configured.</p>
<b>Auto switch to Serial</b>	<p>If selected, the S600+ will revert to using serial communications once available.</p> <p><b>Note:</b> This option is available <b>only</b> if you select SERIAL + PULSE I/P in the Flow Source.</p>
<b>Calc Type</b>	<p>Sets which calculations the system uses with ultrasonic meters. Click ▼ to display all valid calculations.</p> <hr/> <p><b>Daniel Equations</b> Use Daniel equations for ultrasonic meter calculations.</p> <hr/> <p><b>ISO17089 Equations</b> Use ISO 17089-1 Annex E (Daniel ultrasonic meters, correction of meter geometry) for ultrasonic meter calculations.</p>

<b>Field</b>	<b>Description</b>
<b>Transducer Separation</b>	Enter the distance, in millimeters, between the first and second transducer. <b>Note:</b> <ul style="list-style-type: none"> <li>▪ This field displays <b>only</b> in you select <b>ISO17089 Equations</b> in the Calc Type field.</li> <li>▪ Enter the average of the transducer separations.</li> </ul>
<b>Distance Between the Flanges</b>	Enter the distance, in millimeters, between the inlet and outlet flanges of the meter body. <b>Note:</b> This field displays <b>only</b> in you select <b>ISO17089 Equations</b> in the Calc Type field.
<b>Number of Bounces</b>	Enter the number of reflections in the path between transducers. Set to 0 (For Daniel USM) <b>Note:</b> This field displays <b>only</b> in you select <b>ISO17089 Equations</b> in the Calc Type field.
<b>Temperature Coef</b>	Sets the temperature coefficient of the pipe. The default is <b>6e-005</b> .
<b>Calib Temperature</b>	Indicates the calibrated temperature of the pipe. The default is <b>20</b> .
<b>Calib Pressure</b>	Indicates the calibrated pressure of the pipe. The default is <b>1</b> .
<b>Pipe Inside Diameter</b>	Indicates the inside diameter of the pipe. The default is <b>300</b> .
<b>Pipe Outside Diameter</b>	Indicates the outside diameter of the pipe. The default is <b>350</b> .
<b>Young's Modulus</b>	Indicates the Young's Modulus value of the pipe. The default is <b>2070000</b> .
<b>Poisson's Ratio</b>	Indicates the Poisson's Ratio value of the pipe. The default is <b>0.3</b> .
<b>Comms Settings</b>	Click to display the I/O comms screen.
<b>I/O PRESS</b>	Click to display an Analog Input dialog box you use to define various values for the analog input.
<b>I/O TEMP</b>	Click to display an Analog Input dialog box you use to define various values for the analog input.

3. Click in the hierarchy menu when you finish defining settings. A confirmation dialog box displays.
4. Click **Yes** to apply your changes. The PCSetup screen displays.

## 6.10 Modes of Operation

Following are the modes of operation for the S600+:

Mode	Description
<b>Average</b>	Uses the value obtained from the average of the last two readings. Used on the Analog and PRT/RTD inputs.
<b>Average (Density)</b>	Uses the value obtained from the average of densitometer A and densitometer B. Use when you select the Twin Density densitometer option during generation of the configuration. <b>Note:</b> This option is <b>not</b> valid if there is only a single densitometer connected to the flow computer.
<b>Calculated</b>	Uses the calculated value obtained from the relevant calculation for the selected item. This option is often used when there is a simple choice between one calculated result and a fallback keypad value.
<b>Check</b>	Uses a check value to allow a flow computer to be more easily checked. This option is normally used for density and turbine inputs when a check period or frequency can be entered. This option is normally only valid if the flow computer is in maintenance mode.
<b>Chromat</b>	Uses the "live" values obtained from the chromatograph controller for the selected item.
<b>Compress</b>	Uses the value obtained from compressibility calculations for the selected item. This mode uses the calculation you select during the generation of the configuration and is calculated by the same calculation used to produce the compressibility at meter conditions, such as AGA8, ISO6976, and GPA2172-ASTMD3588.
<b>Corrected</b>	Uses the value that has been corrected from one condition to another. As an example, the pipe diameter will be a calibrated diameter at a known temperature. If the current temperature is different to the calibrated temperature, the corrected pipe diameter will be the diameter corrected to current temperature conditions.
<b>CV</b>	Uses the calorific value and uses the compressibility value at base conditions calculated by ISO6976 or GPA2172-ASTMD3588. This mode uses the calculation you select during the generation of the configuration.
<b>Dens A</b>	Uses the value obtained from Densitometer A. Used on the Density inputs.
<b>Dens B</b>	Uses the value obtained from Densitometer B. Used on the Density inputs. <b>Note:</b> This option is not valid if there is only a single densitometer configured.
<b>Keypad</b>	Uses a value entered on the keypad or web access server interface or fallback value for the selected item.
<b>Lastgood</b>	Uses the last good value obtained from the input. Used on analog and PRT/RTD inputs.
<b>Measured</b>	Uses the measured value from a transmitter for the selected item. The measured value is converted from the raw input prior to use. As an example a pressure input would be first seen by the flow computer as raw current (mA) value but will be displayed as the calculated pressure value according to the scaling of the input.

## 6.10.1 Density Failure Modes

Following are the failure modes of operation for the S600+:

### **KF and MF Linearisation**

You may enter a 16-point curve for both K-factors and meter factors.

The curves consist of pairs of turbine frequency versus K-factor and turbine frequency versus meter factor points and linear interpolation based on turbine frequency is performed between these points.

The polynomial curve fit (US requirement) is not yet implemented.

The in-use K-factor and meter factor may be selected from the linearised (calculated) values or from an operator entered keypad value. Any combination of linearised/keypad K-factor and meter factor is selectable.

On completion of a successful prove, the prover micro is able to download a new K-factor or meter factor and associated turbine frequency to the stream. These values are placed in the K-factor or meter factor curves by overwriting the entries nearest to them in the existing curves.

### **Density**

The system supports single or twin densitometer.

A densitometer fail frequency is included in the system and if a densitometer falls below this frequency it is deemed to have failed and the corresponding density value is set to zero. This prevents negative densities arising from very low frequency inputs.

Currently there is no densitometer fail upper limit. Any frequency is considered OK. In practice the hardware will be the limiting factor.

On detection of a densitometer failure an alarm occurs:

- FAIL A – Dens A has failed
- FAIL B – Dens B has failed

These alarms are suppressed in maintenance mode and below low flow cut off. You can enter a densitometer check period for test purposes. This is only possible only in maintenance mode.

Densitometer failure handling:

- If KEYPAD is selected, density stays in KEYPAD mode.
- If DENS A is selected:
  - If transducer A is OK, DENS A remains selected.
  - If transducer A fails, DENS B automatically selected.

# Chapter 7 – Advanced Setup Configuration

## In This Chapter

7.1	Conversions/Constants .....	7-1
7.1.1	Editing Conversions/Constants.....	7-1
7.2	Totals Descriptors.....	7-2
7.2.1	Editing Totals Descriptions .....	7-3
7.3	Alarms.....	7-3
7.3.1	Editing Alarms .....	7-4
7.3.2	Alarm Descriptions .....	7-6
7.4	Security .....	7-15
7.4.1	Editing Security.....	7-15
7.4.2	Editing/Deleting Passwords .....	7-17
7.4.3	Data Item Security.....	7-18
7.4.4	PCSetup Editor Login .....	7-20
7.5	Displays/Webserver.....	7-21
7.5.1	Editing Displays/Webserver .....	7-22
7.6	Calc Explorer.....	7-23
7.6.1	Calc Explorer Options.....	7-24
7.6.2	Adding an Item .....	7-25
7.6.3	Adding All Inputs.....	7-27
7.6.4	Adding All Outputs .....	7-28
7.6.5	Deleting Items .....	7-29
7.6.6	Saving as Bitmaps .....	7-30

You initially define the Advanced settings—which include conversion factors, totals descriptors, alarm mappings, Passwords and stream-to-station mappings—when you create an S600+ configuration file. To edit these settings, select Advanced Setup in the PCSetup Editor.

## 7.1 Conversions/Constants

S600+ acquires the default conversion factors from the API Publication 2564, Chapter 15. However, you can edit these settings. If the units/conversions have been changed elsewhere, change the values in Conversions including Density of Water.

**Note:** The S600+ **does not perform unit conversions on coefficients**. For that reason, always ensure that the coefficients are related to the selected units. For example, if the Gas Orifice Stream units are in degrees Celsius and millimeters, make sure the expansion coefficients for the Orifice and Pipe diameters are values corresponding to  $m^3/mm^{\circ}C$ .

### 7.1.1 Editing Conversions/Constants

To edit the conversion factors:

1. Select **Conversions/Constants** from the hierarchy menu. The Conversions/Constants screen displays.

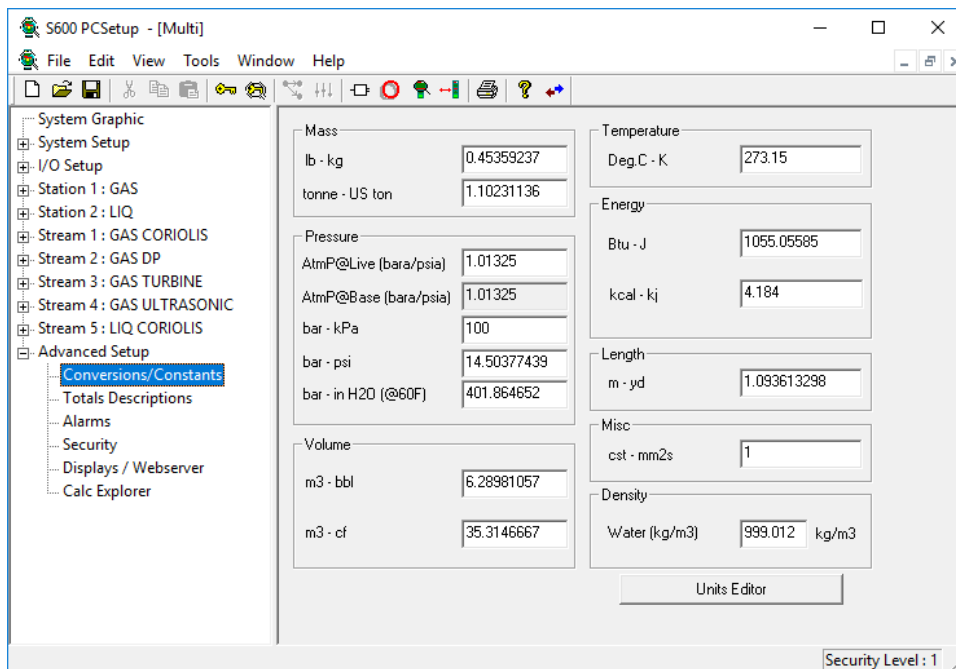

Figure 7-1. Conversion/Constants screen

2. Review and modify the conversion factor values for **Mass, Volume, Temperature, Energy, Length, Misc, and Density.**
3. Complete the values in the **Pressure** pane in psia or bara. The local pressure displays in the engineering units you select.

**Notes:**

- Click **Units Editor** to switch between the Conversions/Constants screen and the Units option in System Setup.
- The **AtmP@Live (bara/psia)** can be updated to reflect the actual atmospheric pressure value based on the pressure units selected.

4. When you are through defining the settings, click in the hierarchy menu. A confirmation dialog box displays.
5. Click **Yes** to apply the changes. The PCSetup screen displays.

## 7.2 Totals Descriptions

Config600 applies any changes you make on the Totals Descriptions screen elsewhere in the configuration and uses these descriptions for totals calculations.

**Note:** The system displays abbreviated short descriptions on the front panel, remote front panel and reports. The system creates these short descriptions based on the standard descriptions. For example, “STR01 UVOL” becomes “UVOL” and “PRV01 MASS.” These short descriptions are **only** created for the standard descriptions. If you change a description, the system



does not create a short description and instead displays the new full description in the short description field.

## 7.2.1 Editing Totals Descriptors

To edit the descriptor for any of the listed totals:

1. Select the **Totals Descriptors** component from the hierarchy menu. The Totals Descriptors screen displays.

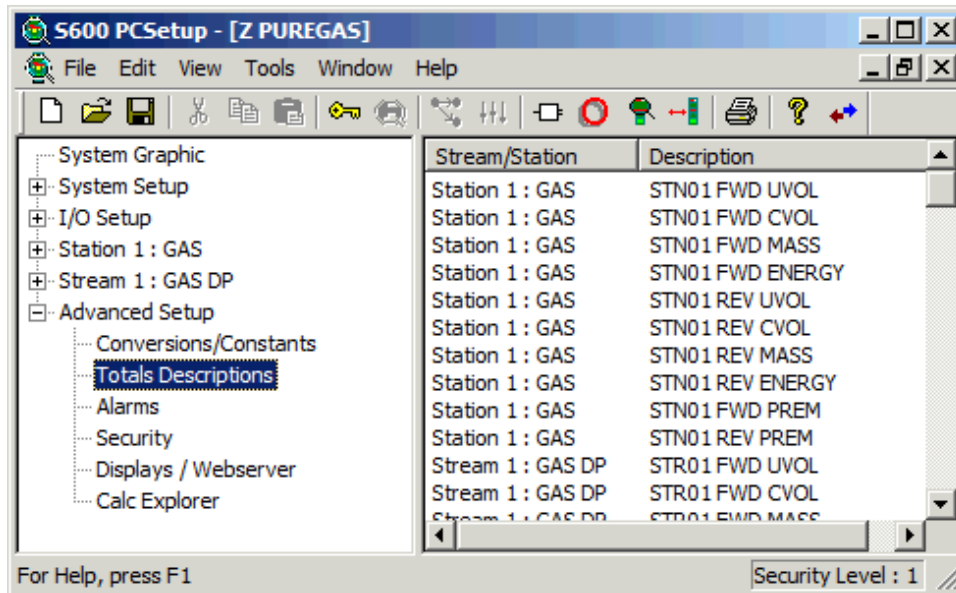

Figure 7-2. Totals Descriptor screen

2. Double-click a **Description**. The system displays an Edit Description dialog box.

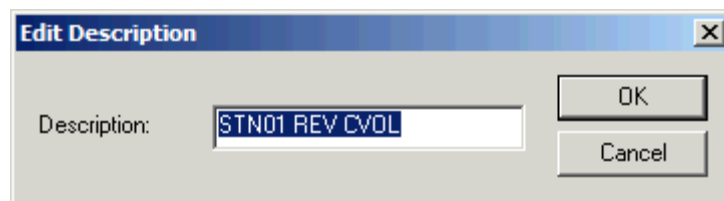

Figure 7-3. Edit Description dialog box

3. Edit the **Description** as necessary.
4. Click **OK** to apply your edits. The Totals Descriptor screen redisplay showing your new description.

## 7.3 Alarms

Config600 allows you to individually enable or disable S600+ alarms. You can also establish up to 16 alarm groupings (for ease of polling) or poll alarms individually. Normally you do not need to change the default alarm groups for each alarm.

Config600 defines three default alarm groups.

- **Computer** (Group 1). This group generally includes failures of the computer or the program internally.

**Note:** This alarm is permanently routed to the watchdog alarm relay on the CPU module’s processor board. You cannot remove this routing, since it is implicit in the S600+ code (see *Chapter 3, CPU Module*, in the *FloBoss S600+ Flow Computer Instruction Manual* (part D301150X412).

- **Process** (Group 2). This group generally includes limits, such as a high or low Analog Input.
- **System** (Group 3). This group generally includes I/O failures, such as an under-range alarm on an Analog Input.

You can define up to 13 more report groupings.

The Available Alarms dialog box lists all of the system modules, which have associated alarms. Config600 displays the associated alarms as you select the module. A check indicates the enabled alarms.

### 7.3.1 Editing Alarms

To edit the alarm configuration: :

1. Select the **Alarms** component from the hierarchy menu. The Alarms screen displays.

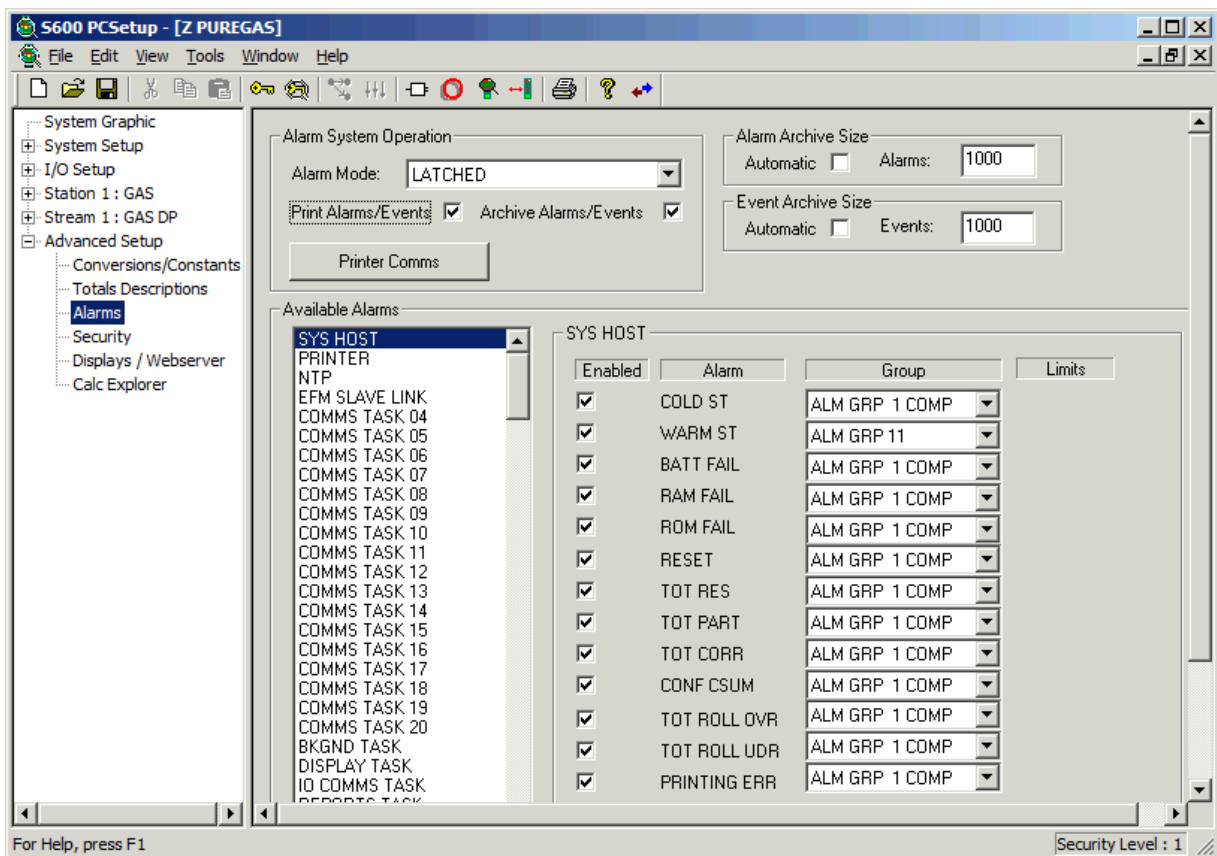

Figure 7-4. Alarms screen

2. Select Alarm System Operation parameters:

Field	Description
<b>Alarm Mode</b>	Indicates whether the system reports or time-stamps an alarm as cleared once it has been acknowledged. Valid values are:
<b>Latched</b>	Prevents system from reporting or time-stamping an alarm as cleared until it has been acknowledged; the value automatically sets when entering an alarm value and clears when leaving the alarm value. <b>Note:</b> The default value is <b>Latched</b> .
<b>Unlatched</b>	System reports and time-stamps an alarm as cleared as soon as the error conditions have been resolved; value automatically sets when entering an alarm value and automatically clears when leaving the alarm value. <b>Note:</b> Selecting Unlatched may result in the alarm log filling up more quickly when fleeting alarms occur.
<b>Print Alarms/Events</b>	Select this check box to send alarm reports to the printer as they are raised, cleared, and acknowledged.
<b>Archive Alarms/Events</b>	Select this check box to save alarm reports to an alarm history file. You can still query on these values.
<b>Printer Comms</b>	Click to access the Printer definition on the Comms Links screen in I/O Setup.

3. Define Alarm Archive Size parameters:

Field	Description
<b>Automatic</b>	Select this check box to automatically save alarms to the Alarm Archive file. <b>Note:</b> If you select this option, you cannot use the Alarms field to indicate a specific number of archived alarms. Instead, the S600+ archives alarms based on memory resources, as well as the settings in the Event Archive Size fields.
<b>Alarms</b>	Indicates the total number of alarms you want to save in the Alarm Archive file. <b>Note:</b> If you complete this field, you cannot use the Automatic function. You may also find that your configuration will not cold start if you do not have enough memory. To resolve this, you may need to reduce the number of alarms saved in the archive file.

4. Define Event Archive Size parameters:

Field	Description
<b>Automatic</b>	Select this check box to automatically save events to the Event Archive file. If you complete this field, you <b>cannot</b> use the Automatic function. <b>Note:</b> If you select this option, you cannot use the Events field to indicate a specific number of archived events. Instead, the S600+ archives events based on memory resources, as well as the settings in the Alarm Archive Size fields.
<b>Events</b>	Indicates the total number of events you want to save in the Event Archive file. <b>Note:</b> If you complete this field, you cannot use the Automatic function. You may also find that your configuration will not cold start if you do not have enough memory. To resolve this, you may need to reduce the number of events saved in the archive file.

5. Select an alarm from the list of available alarms. For example, click on SYS HOST.
6. Enable—or disable—an alarm by selecting each check box.
7. Assign the alarm to a Group, if necessary. Click ▼ to display available alarm groupings.
8. If you enable an object's alarm limit, the Limits field displays the value of that limit.
9. When you are through defining alarms, click in the hierarchy menu. A confirmation dialog box displays:
10. Click **Yes** to apply the changes. The PCSetup screen displays.

### 7.3.2 Alarm and Event Descriptions

The following alphabetic list describes alarm and event codes.

**Note:** The majority of events are self-explanatory. Events that require explanation are listed below.

Code	Description
<b>A-FAIL</b>	Occurs when turbine channel A is either open or has a short circuit.
<b>ABT 1</b>	Occurs when the prover has aborted. The prover displays an error code to assist with diagnosing the cause of the abort.
<b>ADDNLS</b>	Occurs if the additional (ADDitioNaLS) do not add up to 100% or if you have also defined an additional component in the “Splits.”
<b>B-FAIL</b>	Occurs when turbine channel B is either open or has a short circuit.
<b>BAD PULSE</b>	Occurs when the number of bad pulses exceeds the alarm threshold.
<b>BATT FAIL</b>	Occurs when the battery voltage has fallen below 2.8 volts and should be replaced as soon as possible.
<b>BLOCKED</b>	Occurs when the flow computer detected that the filter is blocked.

Code	Description
<b>CALC FAIL</b>	Occurs when a general calculation failure has occurred in this task.
<b>CAN FULL</b>	Occurs when the Sampler can is 100% full.
<b>CAN HIGH</b>	Occurs when the Sampler can contents exceed the high alarm limit.
<b>CHROM TELEM CONFIG</b>	Occurs when a new analysis is available from the GC, but a fault associated with the MOLE SELECT SPLITS or ADDNLS alarms is present.
<b>CHROM TELEM CRITICAL</b>	Occurs when the GC is indicating a Critical alarm. See <i>Section K.4.7, Critical Alarms</i> .
<b>CHROM TELEM MOLE DV</b>	Occurs when a component, or the total, of the new composition set from the GC is deviates from the previously received value by more than the limit. See <i>Section K.4.3, Deviation</i> .
<b>CHROM TELEM MOLE HI</b>	Occurs when a component, or the total, of the new composition set from the GC is higher than the high limit. See <i>Section K.4.2, High/Low Limits</i> .
<b>CHROM TELEM MOLE LO</b>	Occurs when a component, or the total, of the new composition set from the GC is lower than the low limit. See <i>Section K.4.2, High/Low Limits</i> .
<b>CHROM TELEM NCRITICAL</b>	Occurs when the GC is indicating a Non Critical alarm. See <i>Section K.4.8, Non-Critical Alarms</i> .
<b>CHROM TELEM REP TOUT</b>	Occurs when the GC has not indicated that a new composition set is available within the timeout period specified. See <i>Section K.4.9, Timeouts</i> .
<b>CHROM TELEM RX FAIL</b>	Occurs when the timeout period for the GC to respond has expired. See <i>Section K.3, Chromat Telemetry</i> .
<b>COLD ST</b>	Occurs when the S600+ has performed a Cold Start, all settings have been re-initialized.
<b>COMMON</b>	Occurs when any of the alarms in displayed group occur. This is a common alarm if you use only a minimum alarm set. You then need to determine the cause of the problem.
<b>COMPLETE</b>	Occurs when the batch total is greater than the required total (that is, the batch has completed).
<b>CONF CSUM</b>	Occurs when parameters in the configuration (CONFiguration CheckSUM) have changed. The S600+ calculates a configuration checksum as part of its background tasks and compares it against the previous checksum on a rolling basis.
<b>CONF ERR</b>	Occurs when there is an error in the configuration (CONFig ERRor). Remove the S600+ from service if this alarm occurs and immediately contact either the person who configured your application or technical support personnel. <b>Note:</b> This alarm can also occur from the IO Section. If an I/O board CONF ERR occurs, remove the S600+ from service and exchange the faulty I/O board with a replacement before returning the S600+ to service.
<b>CONFIG</b>	Occurs when either the Additional or Splits (CONFiguration error) are in error. This alarm is only raised on receipt of a good composition.
<b>CONFIG CHG</b>	Occurs when the configuration held in the Coriolis transmitter has changed.
<b>CRC FAIL</b>	Occurs when the S600+ receives a bad checksum.

<b>Code</b>	<b>Description</b>
<b>CRITICAL</b>	Occurs when S600+ receives either a Critical or Non-Critical alarm from an attached 2251, 2551 or 2350 chromatograph controller. The following alarms have been classified as Critical and Non-Critical on a 2551 EURO or 2350 EURO European chromatograph controller:
<b>CRITICAL</b>	Peak Overflow, Unknown Error, Peak Analysis, Peak Analysis Start, I/O Start Failure, Stack Overflow, Buffer Overflow, Input Out of Range, Preamp Fail, Autostart Fail, Analysis Fail, Autostart Alarm.
<b>NON-CRITICAL</b>	ADC 1 Fail, ADC 2 Fail, ADC 3 Fail, Preamp Adjust, Calibration Fail, 24 Hour Average.
	The following alarms have been classified as Critical and Non-Critical on a 2251 USA or 2350 USA chromatograph controller:
<b>CRITICAL</b>	Preamp Fail, Analysis Fail.
<b>NON-CRITICAL</b>	ADC 1 Lo or Failed, ADC 2 Lo or Failed.
<b>DATA TOUT</b>	Occurs when the Ultrasonic Meter has failed to communicate within the time-out period. This forces the flowrate to zero.
<b>DENIED</b>	Occurs when the selection algorithm has determined that a range change is required but no suitable cell is available.
<b>DENS LIMIT</b>	Occurs when the density of the Coriolis transmitter is out of limits.
<b>DEV ERR</b>	Occurs when any of the alarms (DEVICE ERROR) in displayed group occur. This is a common alarm if you use only a minimum alarm set. You then need to determine the cause of the problem.
<b>DEV OPEN</b>	Occurs when the I/O module has failed to communicate correctly with the identified device (DEVICE OPEN). A system fault.
<b>DISCREP</b>	Occurs when operating within range and a discrepancy in the engineering values returns from two or more cells.
<b>DL COMP</b>	Occurs when that the downloaded set has been rejected. This can be because one of the components is outside the limits for that component or because the sum of the downloaded components is less than 98% or greater than 102%. <b>Note:</b> No normalisation of a download set occurs - the downloaded composition is expected to already be normalised to 100%.
<b>DL T/OUT</b>	Occurs when the S600+ has not received an updated composition from the supervisory system within the configured Download Timeout period.
<b>DP INCREMENT I/P ERR</b>	Occurs when differential pressure is not greater than or equal to 0.0.
<b>DRV GAIN</b>	Occurs when the Drive Gain of the Coriolis transmitter has gone over range.

<b>Code</b>	<b>Description</b>
<b>DSCR P</b>	Occurs when the identified variable exceeds the discrepancy limit (DiSCRePancy) from the check value for longer than the time-out period. This alarm is used where two transducers are checked against each other or where the process variable is checked against previous values.
<b>EEPROM FAIL</b>	Occurs when a Checksum failure has been detected in the Coriolis transmitter.
<b>ERROR</b>	Occurs when the Coriolis transmitter has reported an error.
<b>EVENT 1</b>	Occurs when the Coriolis transmitter has reported that Event 1 is ON.
<b>EVENT 2</b>	Occurs when the Coriolis transmitter has reported that Event 2 is ON.
<b>EXCEPTION</b>	Occurs when a Modbus Exception reply has been received from the other computer.
<b>FAIL A</b>	Occurs when the densitometer frequency is below 1Hz, or the measured period is outside the period limits, or the calculated density is negative.
<b>FAIL B</b>	Occurs when the densitometer frequency is below 1Hz, or the measured period is outside the period limits or the calculated density is negative.
<b>FAIL CH_A</b>	For Daniel Gas Ultrasonic meters, occurs when bit 14 of the CHORD A status byte is set.
<b>FAIL CH_B</b>	For Daniel Gas Ultrasonic meters, occurs when bit 14 of the CHORD B status byte is set.
<b>FAIL CH_C</b>	For Daniel Gas Ultrasonic meters, occurs when bit 14 of the CHORD C status byte is set.
<b>FAIL CH_D</b>	For Daniel Gas Ultrasonic meters, occurs when bit 14 of the CHORD D status byte is set.
<b>FAIL IO'x' (1-7)</b>	Occurs when I/O module 'x' has failed to communicate.
<b>FAIL WARN</b>	Occurs when any of the alarms in displayed group has been raised. This is a common alarm if you use only a minimum alarm set. You then need to determine the cause of the problem.
<b>FATAL CRD</b>	For Daniel Gas Ultrasonic meters, occurs when bit 8 of the SYSTEM STATUS byte is set.
<b>FIXED VEL</b>	Occurs when a keypad-entered flow velocity is in use.
<b>FRQ O-RNGE</b>	Occurs when the Coriolis reports the frequency is over range.
<b>H</b>	Occurs when the In-Use value for the identified variable exceeds the Hi alarm limit.
<b>HH</b>	Occurs when the In-Use value for the identified variable exceeds the Hi Hi alarm limit.
<b>HIGH PRD</b>	Occurs when the Measured period exceeds (HIGH PeRioD) the high period alarm limit.
<b>H/W FAIL</b>	For Daniel Gas Ultrasonic meters, occurs when bits 1, 2, 3, 4, 5, 6 and 7 of the SYSTEM STATUS byte is set.
<b>ILLEGAL</b>	Occurs when the valve status inputs indicate that the valve is not in a valid position (that is, not Open, Closed, or Moving).
<b>INTEG-FAIL</b>	Occurs when the S600+ detects the constant current for the PRT/RTD circuitry to be outside the range 0.8 mA to 1.5 mA (INTEGrity FAIL).
<b>INVALID INC</b>	Occurs when the S600+ receives an invalid increment from the Coriolis transmitter.

<b>Code</b>	<b>Description</b>
<b>I/P ERR</b>	Occurs when an input to the calculation is outside the valid range.
<b>IP O-RNGE</b>	Occurs when the Coriolis transmitter reports an input is over range.
<b>K_COMP</b>	Occurs when the keypad entered composition is outside the limits set on the Gas Composition page on PCSetup. This check applies to the total and the individual components.
<b>L</b>	Occurs when the In-Use value for the identified variable falls below the Low alarm limit.
<b>LL</b>	Occurs when the In-Use value for the identified variable falls below the Low Low alarm limit.
<b>LINK 'x' (1-10)</b>	Occurs when slave address 'x' is in fault condition.
<b>LOW FLOW</b>	Occurs when the flow rate falls below the low flow rate alarm limit set on the sampler page of PCSetup.
<b>LOW PRD</b>	Occurs when the Measured period falls below the low period (LOW PeRioD) alarm limit
<b>MA IP ERR</b>	Occurs when the Coriolis transmitter reports a failure of its analog input.
<b>MA OP FXD</b>	Occurs when the analog outputs of the Coriolis transmitter have been fixed.
<b>MA OP SAT</b>	Occurs when the analog outputs on the Coriolis transmitter are saturated.
<b>MOLE DV</b>	Occurs when any component (MOLE DeViation) exceeds the deviation limit percentage set up in PCSetup on the Gas Composition page. This alarm is raised for the complete composition; diagnose the component that is in error.
<b>MOLE HI</b>	Occurs when any component exceeds the highest acceptable percentage set up in PCSetup on the Gas Composition page. This alarm is raised for the complete composition; diagnose the component that is in error.
<b>MOLE LO</b>	Occurs when any component falls below the lowest acceptable percentage set up in PCSetup on the Gas Composition page. This alarm is raised for the complete composition; diagnose the component that is in error.
<b>MOLE SELECT ADDNLS</b>	Occurs when an additional component is outside of the low or high limit, an additional component is also present in the composition set from the GC, or an additional component is also defined in the Mole Splits set. See <i>Section K.4.5, Additional</i> s.
<b>MOLE SELECT DL COMP</b>	Occurs when a component, or the total, of the Download composition set is outside of the low or high limit. See <i>Section K.4.2, High/Low Limits</i> .
<b>MOLE SELECT K_COMP</b>	Occurs when a component, or the total, of the keypad entered composition set is outside of the low or high limit. See <i>Section K.4.2, High/Low Limits</i> .
<b>MOLE SELECT SPLITS</b>	Occurs when the entered Mole splits do not add up to 100%. See <i>Section K.4.6, Splits</i> .
<b>MOLE SELECT USER COMP</b>	Occurs when a component, or the total, of the User composition set is outside of the low or high limit. See <i>Section K.4.2, High/Low Limits</i> .



<b>Code</b>	<b>Description</b>
<b>MONITOR</b>	Occurs when the software watchdog time has timed-out for this task. <b>Note:</b> If this alarm is raised on a Modbus Master TCP task, it indicates that the communications link has been broken (i.e. the S600+ master cannot open a connection to the slave) and has therefore caused the software watchdog to time out.
<b>MOVE FAIL</b>	Occurs when the valve has not reached the required position within the allowable time-out period.
<b>MOVE UNCM</b>	Occurs when the valve has moved position without any command being issued (MOVE UNCoMmanded).
<b>NCRITICAL</b>	Refer to CRITICAL.
<b>NEG FLOW</b>	Not used.
<b>NO PERMIT</b>	Occurs when an item in the configuration is locked or write protected by the flow computer.
<b>O-FLOW</b>	Occurs when the high frequency limit has been exceeded. Some pulses may be unaccounted for.
<b>O-RANGE</b>	Occurs when the raw input exceeds acceptable values. For Analog Inputs this value can be entered but defaults to 20.5 mA. For PRT/RTD inputs the limit is 216 ohms. For the case of the Analog Outputs, the value to be output is higher than the high scale value.
<b>O/P ERR</b>	Occurs when an output to the calculation is outside the valid range.
<b>OVERFLOW</b>	Occurs when the Pulse Output cannot match the required pulse rate or when the number of pulses to be output exceeds the pulse reservoir.
<b>PATH 1 ERROR</b>	For SICK Ultrasonic meters occurs when bit 5 of the SYSTEM STATUS byte is set.
<b>PATH 2 ERROR</b>	For SICK Ultrasonic meters occurs when bit 6 of the SYSTEM STATUS byte is set.
<b>PATH 3 ERROR</b>	For SICK Ultrasonic meters occurs when bit 7 of the SYSTEM STATUS byte is set.
<b>PATH 4 ERROR</b>	For SICK Ultrasonic meters occurs when bit 8 of the SYSTEM STATUS byte is set.
<b>PERIOD END MISSED EVENT</b>	The I/O comms cycle checks for the end of every minute in the S600+. If the end of the minute is missed because the IO task is busy, then this event is raised. <b>Note:</b> <ul style="list-style-type: none"> <li>▪ If the event is raised and it is <b>not</b> a configured period end (i.e. no reports are required), then it is logged for informational purposes.</li> <li>▪ If the event is raised and it is a configured period end, then it is logged for informational purposes and the report will be re-generated to ensure no reports are missed.</li> </ul>
<b>PIC FAIL</b>	Occurs when the S600+ detects a hardware failure of the indicated I/O board (I/O Board Hardware Failure). If this alarm occurs, remove the S600+ from service and replace the faulty I/O board before returning the S600+ to service.
<b>PR OP FXD</b>	Occurs when the primary Analog Output of the Coriolis transmitter is in fixed mode.
<b>PR OP SAT</b>	Occurs when the primary Analog Output of the Coriolis transmitter is saturated.

<b>Code</b>	<b>Description</b>
<b>PRE WARN</b>	Occurs when a batch is at 'n%' where 'n' is set on the Batching page in PCSetup.
<b>PRINTING ERR</b>	Occurs when the internal printer queue is filled. This may clear if the printer is made available but some data may have been lost. <b>Note:</b> When requesting report printouts, a five second delay should be observed between print requests to allow the report to be generated.
<b>PWR RESET</b>	Occurs when a power reset occurs on the Coriolis transmitter.
<b>RESET</b>	Not used.
<b>RAM FAIL</b>	Occurs if the S600+ detects a discrepancy between the data written to and from RAM. The S600+ continually writes data to RAM and reads it back for comparison. If this alarm occurs, remove the S600+ from service. <b>Note:</b> This alarm is also used to check the I/O board RAM; the alarm indicates the area of failure.
<b>REP MISSED</b>	Occurs if a periodic report has not been generated due to CPU Overloading.
<b>ROM FAIL</b>	Occurs if the S600+ detects a discrepancy between the S600+-calculated checksum and a preset checksum. If this alarm occurs, remove the S600+ from service. <b>Note:</b> This alarm is also used to check the I/O board ROM; the alarm indicates the area of failure.
<b>ROC</b>	Occurs when the ROC (Rate Of Change) exceeds the alarm limit for the identified variable.
<b>RT INT</b>	Occurs when the Coriolis transmitter has had a Real Time interrupt failure.
<b>RX FAIL</b>	Occurs when the reply from the slave computer has not been received within the time-out period.
<b>SAMPLER</b>	Occurs when the sampler has been commanded to reset by the batching, but has not reset.
<b>SCALING</b>	Occurs when the scaling values for the identified variable are either the same or the high scale value is lower than the low scale value.
<b>SEAL FAIL</b>	Occurs when the valve reports that it has not sealed during the test period.
<b>SEC BREACH</b>	Occurs when a security breach has been detected in the Coriolis meter.
<b>SEC OP SAT</b>	Occurs when the secondary Analog Output of the Coriolis transmitter is saturated.
<b>SEC OP FXD</b>	Occurs when the secondary Analog Output of the Coriolis transmitter is in fixed mode.

<b>Code</b>	<b>Description</b>
<b>SEL TO BASE I/P ERR</b>	Occurs when a density input is out of range. Possible inputs include: <ul style="list-style-type: none"> <li>▪ Density Units</li> <li>▪ Product Type</li> <li>▪ CPL Calc Type</li> <li>▪ Rounding Enable</li> <li>▪ REF Temperature</li> <li>▪ Alpha</li> <li>▪ FFactor</li> <li>▪ Iteration Type</li> <li>▪ HYC Enable</li> <li>▪ OBS Density</li> <li>▪ OBS Temp</li> <li>▪ OBS Press</li> <li>▪ Pe</li> <li>▪ Aromatic Product</li> <li>▪ Aromatic Density</li> <li>▪ PE100</li> <li>▪ PE Calc Type</li> </ul> <p>The limits to these inputs are user-defined based on the data type.</p>
<b>SELECT</b>	Occurs when all cells have failed (a fatal cell selection error) or are in Keypad mode.
<b>SELF CALIB</b>	Occurs when the Coriolis transmitter performs a self-calibration.
<b>SENS FAIL</b>	Occurs when a Sensor failure is detected at the Coriolis transmitter.
<b>SLUG FLOW</b>	Occurs when the Coriolis transmitter reports slug flow.
<b>SPEED</b>	Occurs when the Pulse Output for the sampler cannot match the required pulse rate. The number of pulses to be output has exceeded the pulse reservoir.
<b>SPLITS</b>	Occurs if the total of the splits does not equal 100%.
<b>STOPPED</b>	Occurs when the sampler has stopped.
<b>TASK ERR</b>	Occurs when a task within the I/O module detects an error.
<b>TASK FAIL</b>	Occurs when a task within the I/O board fails.
<b>TEMP FAIL</b>	Occurs when the Coriolis temperature sensor fails.
<b>TOT CORR</b>	Occurs when all three totals tri-registers disagree (TOTals CORRupt). Totalization is inhibited. Take the S600+ out of service and perform a Totals Reset.
<b>TOT PART</b>	Occurs when only two of the three totals tri-registers agree (TOTals PARTIally corrupt). The S600+ corrects the third register automatically and clears the alarm.
<b>TOT RES</b>	Occurs when the totals have been reset to zero (TOTals RESet).
<b>TOT ROLL OVR</b>	Occurs when at least one of the totals within the S600+ reaches its maximum value and rolls over to zero (TOTals ROLL OVer).
<b>TOT ROLL UDR</b>	Occurs when at least one of the totals within the S600+ rolls under zero (TOTals ROLL UnDeR). <b>Note:</b> This should occur only if using reverse totals.

<b>Code</b>	<b>Description</b>
<b>TPU FAIL</b>	Occurs when the S600+ detects a hardware failure of the indicated I/O module (I/O module hardware failure system fault). <b>Note:</b> If this alarm occurs, remove the S600+ from service and replace the I/O module before returning the S600+ to service.
<b>TSK ERR</b>	Occurs when any of the alarms in displayed group occur (TaSK ERRor). This is a common alarm if you use only a minimum alarm set. You then need to determine the cause of the problem.
<b>TSK OFLOW</b>	Occurs when the S600+ traps an attempt to write an infinite number.
<b>TX CONFIG</b>	Occurs when the Coriolis transmitter reports that it is not configured.
<b>TX ELEC</b>	Occurs when the Coriolis transmitter reports an electronics failure.
<b>TX FAIL</b>	Occurs when the S600+ is unable to place the information to the flow computer hardware (system fault).
<b>U-RANGE</b>	Occurs when the raw input falls below acceptable values. For Analog Inputs this value can be entered but defaults to 3.5 mA. For PRT/RTD inputs the limit is 60 ohms. For the case of the Analog Outputs, the value to be output is lower than the low scale value.
<b>UNAVAIL</b>	Occurs when the signal for Local or Remote control from the valve indicates the valve is in local control (UNAVAILable).
<b>UNDEFINED</b>	Occurs when the Coriolis transmitter reports an undefined error.
<b>VCONE I/P</b>	Occurs when a V-Cone input is out of range. Possible cause include: <ul style="list-style-type: none"> <li>▪ Differential pressure is not greater than or equal to 0.0</li> <li>▪ Gas density is not greater than or equal to 0.0</li> <li>▪ (pipe diameter ration) ^4 is not greater than or equal to 1.0</li> </ul>
<b>WARM ST</b>	Occurs when the S600+ performs a Warm Start, possibly due to a power dip or software failure. Settings have been retained. In the I/O alarms section this alarm indicates if an I/O board has restarted.
<b>WARN CH_A</b>	For Daniel Gas Ultrasonic meters, occurs when bit 13 of the CHORD A status byte is set.
<b>WARN CH_B</b>	For Daniel Gas Ultrasonic meters, occurs when bit 13 of the CHORD B status byte is set.
<b>WARN CH_C</b>	For Daniel Gas Ultrasonic meters, occurs when bit 13 of the CHORD C status byte is set.
<b>WARN CH_D</b>	For Daniel Gas Ultrasonic meters, occurs when bit 13 of the CHORD D status byte is set.
<b>WARNING</b>	Occurs when at least one cell has failed or is in Keypad mode.
<b>ZERO DIV</b>	Occurs when the S600+ traps an attempt to divide by zero.
<b>ZERO LOW</b>	Occurs when the zero value of the Coriolis transmitter is too low.
<b>ZERO HIGH</b>	Occurs when the zero value of the Coriolis transmitter is too high.

Code	Description
ZERO NOISE	Occurs when the signal into the Coriolis transmitter is too noisy.
ZERO OP	Occurs when the Coriolis transmitter has failed in its zeroing operations.
ZERO PROG	Occurs when the Coriolis transmitter is currently zeroing.

## 7.4 Security

The Config600 suite of programs is protected by a multi-level security system that both restricts access to authorised system users and determines which data items system users can enter or modify. Each system user is assigned a security access Level (between 1 and 9) **and** a password. Security access Level 1 provides the largest number of privileges; Level 9 provides the fewest number of privileges. Access to any one level provides access to all the other less-privileged levels (that is, Level 3 access has the privileges of Levels 4 through 9 but is denied privileges of Levels 2 and 1).

When you send the configuration to the S600+, the security settings (including the user access levels) become the login Passwords for access via the front panel and webserver.

You can define a maximum of 50 users on each configuration file. You cannot repeat the username or S600+ password for any user, since the S600+ uses this value to determine who logged in when changes are made through the S600+ front panel or PCSetup.

**Note:** By default, PCSetup opens with the user logged on a Level 1 security. To activate the security on PCSetup, you must enter a username and a PCSetup password for Level 1 security (see *Figure 7-5*). The PCSetup program does not allow you to delete Level 1 logins.

If you do not enable Level 1 security at PCSetup, this allows anyone to modify the configuration at PCSetup. The default S600+ front panel password is configured so that only authorized personnel can change data at the S600+ front panel.

**Note:** With Security Level 1, any items you change using the S600+ front panel create checksum alarms. Any objects at Security Level 1 change the NMI checksum. Security Level 1 is activated when jumper P3 is OFF (see *Chapter 3, CPU Module*, in the *FloBoss S600+ Flow Computer Instruction Manual*, part D301150X412).

### 7.4.1 Editing Security

To edit security settings:

1. Select the **Security** hierarchy menu. The Security screen displays.

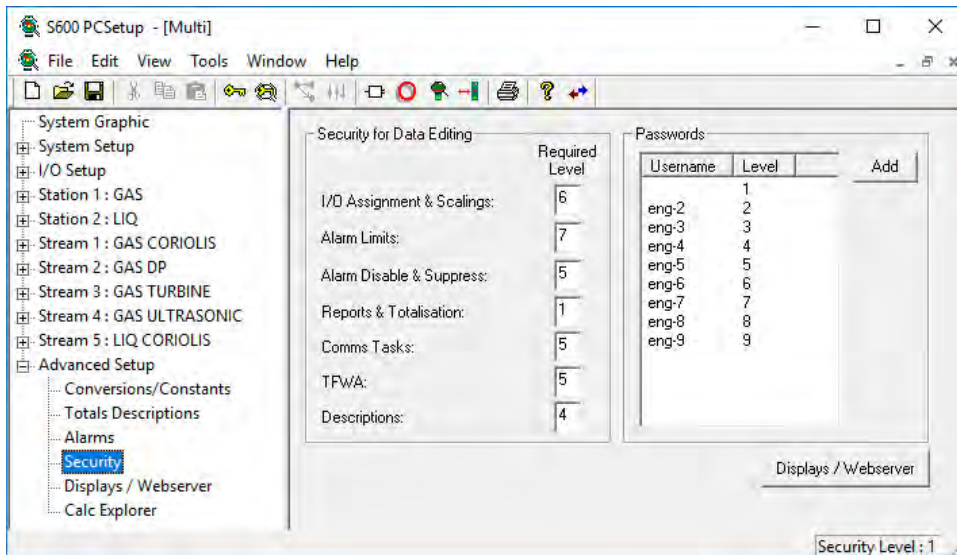

Figure 7-5. Security screen

- Using the Security for Data Editing pane, complete the **Required Level** field to assign an access security level (1 through 9) to each of the PCSetup data item groups. Remember that **1** is the most comprehensive level of access and **9** is the most restrictive level of access.

---

**Note:** Click **Displays/Webserver** to switch between this screen and the Displays/Webserver screen. This helps you determine which functions should have webserver access.

---

- Click **Add** in the Passwords pane to add a Password for an additional user. The Passwords dialog box displays.

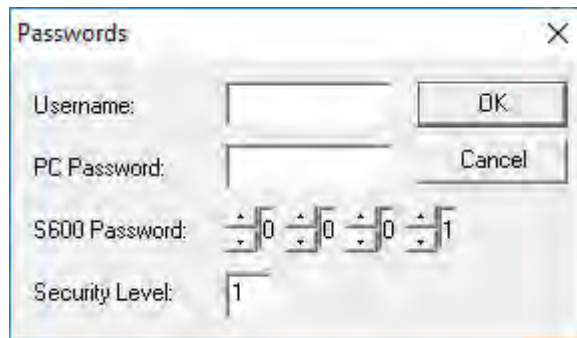

Figure 7-6. Passwords dialog box

- Complete the following fields:

Field	Description
<b>Username</b>	Enter a name the user types to access the relevant program. The S600+ also prints this Username on event logs to show which user logged in to change parameters. <b>Note:</b> <ul style="list-style-type: none"> <li>This value is case-sensitive.</li> <li>Valid special characters are: - . / : = @ [ ] ^ _</li> </ul>

Field	Description
<b>PC Password</b>	Enter an alphanumeric value up to 15 characters in length to log on to the Config600 software applications. For security, a password should be a random combination of numbers and upper- and lower-case letters. <b>Note:</b> <ul style="list-style-type: none"> <li>This value is case-sensitive.</li> <li>Valid special characters are: - . / : = @ [ ] ^ _</li> </ul>
<b>S600 Password</b>	Enter a number (click ▲ or ▼ to increase or decrease the values) the user must provide to change parameters using the S600+ front panel.
<b>Security Level</b>	Enter a number (between 9 and 1) to indicate the Security Level associated with this user ID.

- Click **OK** to apply the changes. The Security screen displays, showing the user ID you have just defined.

**Note:** The following message appears if you enter invalid special characters in the Username or PC Password fields. Valid special characters are: - . / : = @ [ ] ^ \_

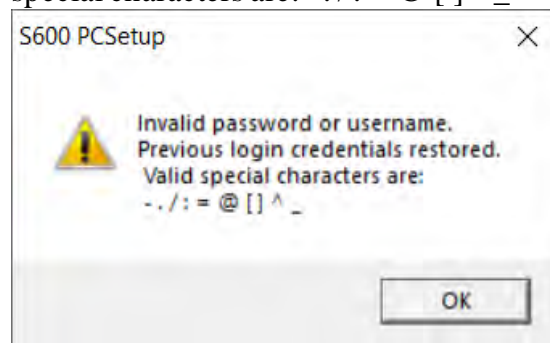

## 7.4.2 Editing/Deleting Passwords

As administrator, you may need to edit, reset, or remove system Passwords:

- Click a username in the Passwords pane. Config600 adds two buttons (**Edit** and **Delete**) to the pane.

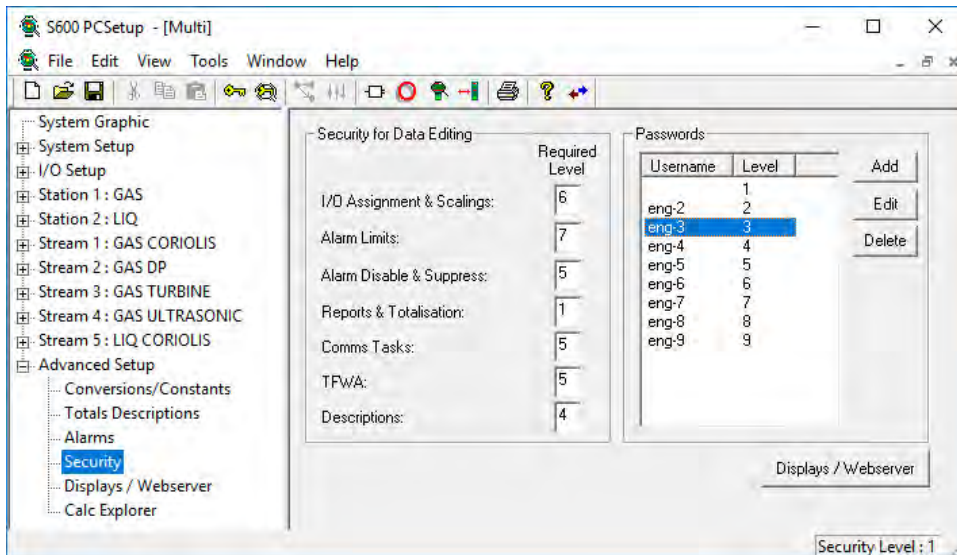

Figure 7-7. Security screen, Password Edits

2. Click **Edit** to display the Passwords dialog box for that username.

**Note:** You can also double-click the username to immediately display the Passwords dialog box.

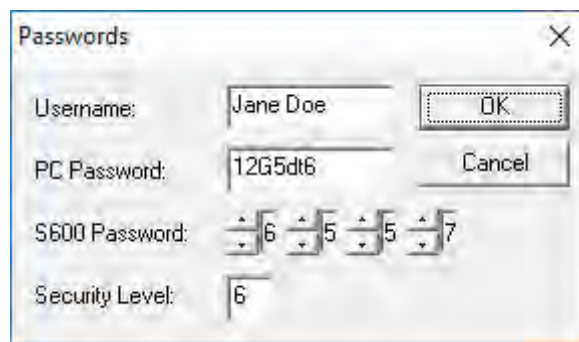

Figure 7-8. Passwords dialog box

**Note:** To delete a password, click **Delete**. Config600 removes the password from the Passwords pane.

3. Modify the content as necessary.
4. Click **OK** to apply your changes. The Security screen displays.

### 7.4.3 Data Item Security

You can also assign security levels to individual data items on the hierarchy menu. This provides an additional level of system security.

**Note:** Because of the variation in the nature of data items, this process varies slightly from data item to data item. This section is presented as an example to familiarize you with the general concept of applying security to data items.

1. Select a **component** from the hierarchy menu (in this example, select **Units** from the System Setup hierarchy).



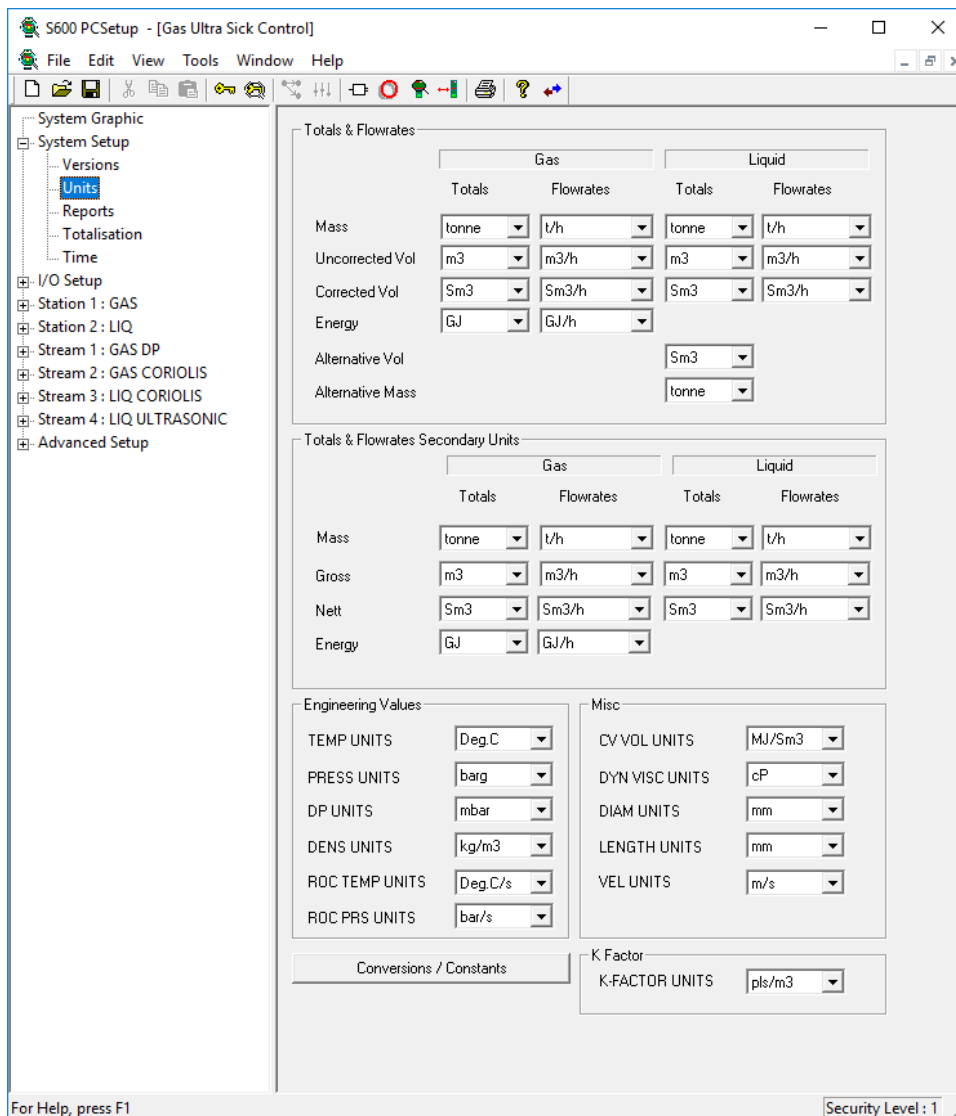

Figure 7-9. Data Item Security

2. Select **Edit > Security** (using the menu bar at the top of the screen). The Security dialog box (in this case, security for units) displays.

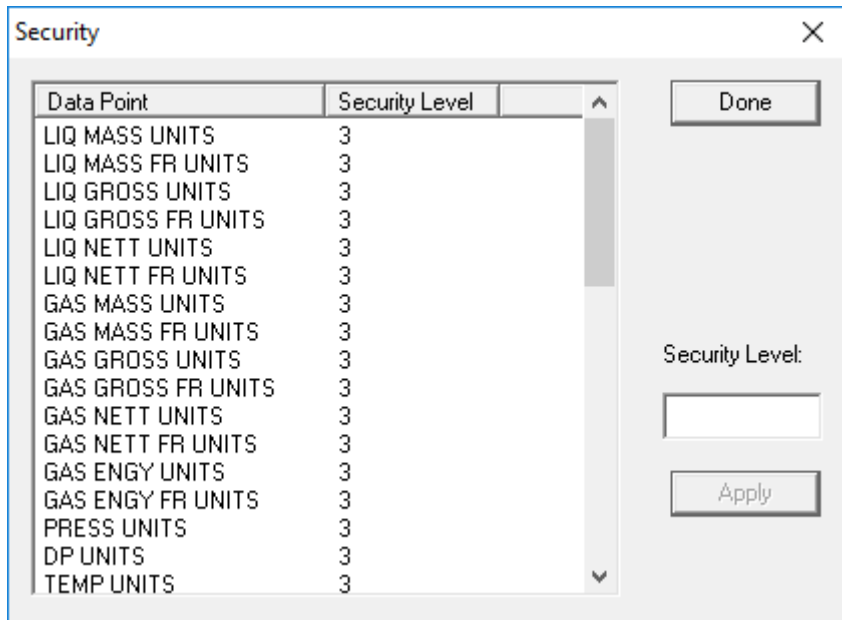

Figure 7-10. Units Security dialog box

3. Review the current **Security Levels**. If appropriate, select a data point from the menu. Config600 completes the Security Level field with that item's current security level.

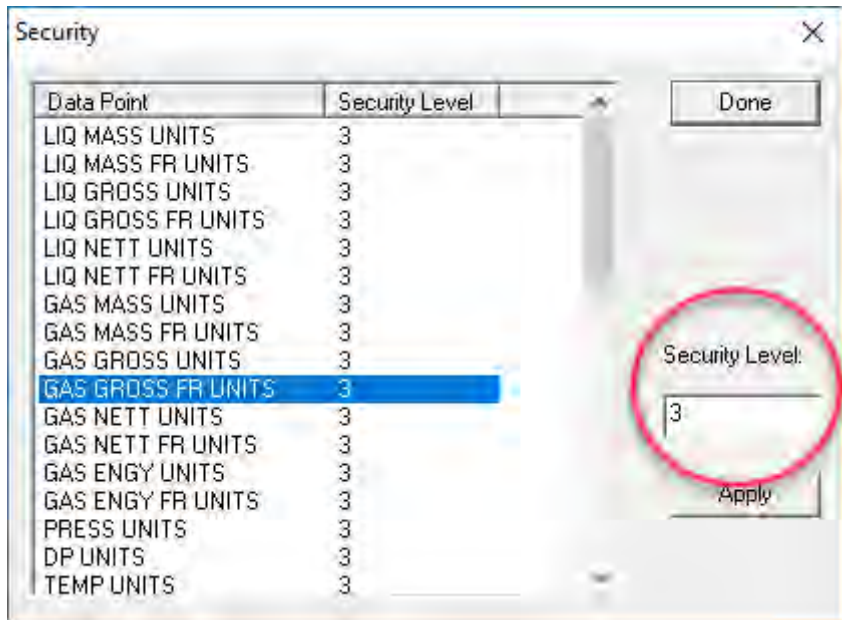

Figure 7-11. Units Security Level

4. Change the value in the **Security Level** field, if necessary.
5. Click **Apply** to apply the change.
6. Once the new value displays in the Security Level column, click **Done** to close the dialog box and redisplay the data item screen.

#### 7.4.4 PCSetup Editor Login

If you enable Level 1 security, Config600 restricts access to the PCSetup Editor by a login procedure. **You cannot make any changes**

or perform any functions in PCSetup Editor until you complete login. Each system user has an assigned security Level that determines the type of data that user can enter or modify.

**Login** To log in to PCSetup:

1. Select **File > Login** from the PCSetup menu bar. The Login dialog box displays.

---

**Note:** You can also click the Login icon  to open the Login dialog box. You see this same dialog box when you open a configuration file using the PCSetup Editor.

---



Figure 7-12. Login dialog box

2. Enter your username.
3. Enter your case-sensitive password. Config600 uses asterisks (\*\*\*) to mask the actual characters you type.
4. Click **OK**. If Config600 recognizes your username and password, the PCSetup screen displays.

**Checksum** Before sending a configuration file to the S600+, Config600 checks the configuration to make sure it has not been manually modified.

Config600 accomplishes this by calculating a checksum on the file. If the calculated and recorded checksums do not match, Config600 displays a warning message. To repair the configuration checksum, you must login to PCSetup with the Level 1 username and password. Once Config600 recognizes and accepts that username and password, it saves the file with the correct checksum. Click **Cancel** to stop Config600 from correcting the checksum.

---

**Note:** You **cannot** transfer a configuration from the host PC to the S600+ with an incorrect checksum.

---

## 7.5 Displays/Webserver

Use the **Displays/Webserver** option to determine what information each security level (1-9) may access using the webserver.



**Caution**

**Once you have assigned users to an access level, verify (and modify, if necessary) the amount of information available to them.**

---

**Note:** Click **Security** to switch between this screen and the Security screen. This helps you determine which functions should have webserver access.

---

## 7.5.1 Editing Displays/Webserver

To edit displays and webserver access:

1. Select the **Displays/Webserver** component from the hierarchy menu. The Displays/Webserver screen displays.

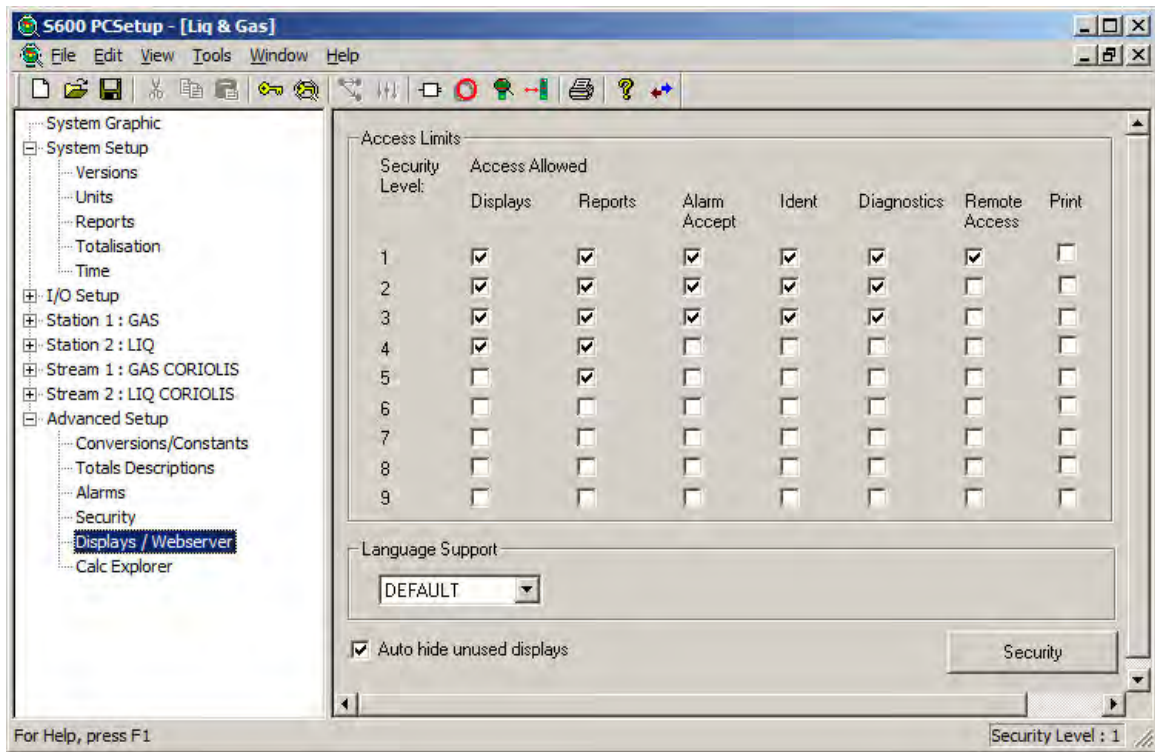

Figure 7-13. Displays/Webserver screen

2. Indicate webserver access options by selecting the appropriate check box.

Option	Description
<b>Displays</b>	Permit access to the S600+ display layouts.
<b>Reports</b>	View history reports and request instantaneous reports.
<b>Alarm Accept</b>	Permit alarm accepting.
<b>Ident</b>	Change data as though logged in through the S600+ front panel (according to your login security Level).
<b>Diagnostics</b>	View diagnostics on S600+ calculations.
<b>Remote Access</b>	Perform system diagnostics. <b>Note:</b> This option is reserved only for use by technical support personnel. Leave all settings at the default values.
<b>Print</b>	Adds a “Print” button (and printing capability) to web server-displayed pages. <b>Note:</b> When requesting report printouts, a five second delay should be observed between print requests to allow the report to be generated.
<b>Language Support</b>	Select the default language.
<b>Auto hide unused displays</b>	Select to hide the screens that do not have data.

Option	Description
Security	Click to display the PCSetup > Advanced Setup > Security screen.

3. Click in the hierarchy menu when you are through editing this screen. A confirmation dialog box displays.
4. Click **Yes** to apply the changes. The Displays/Webserver screen displays.

## 7.6 Calc Explorer

Use the **Calc Explorer** option to access a graphical tool that enables you to analyze how system components link together.

**Note:** Although the option is discussed as part of the Advanced Setup options, you can also access this feature at any time by clicking the Calc Explorer icon on the PCSetup screen's menu bar.

1. You can start Calc Explorer in several ways:

- Click the **Calc Explorer** icon  on the PCSetup Editor's toolbar.
- Select the **Calc Explorer** component from the hierarchy menu.

The Calc Explorer screen displays.

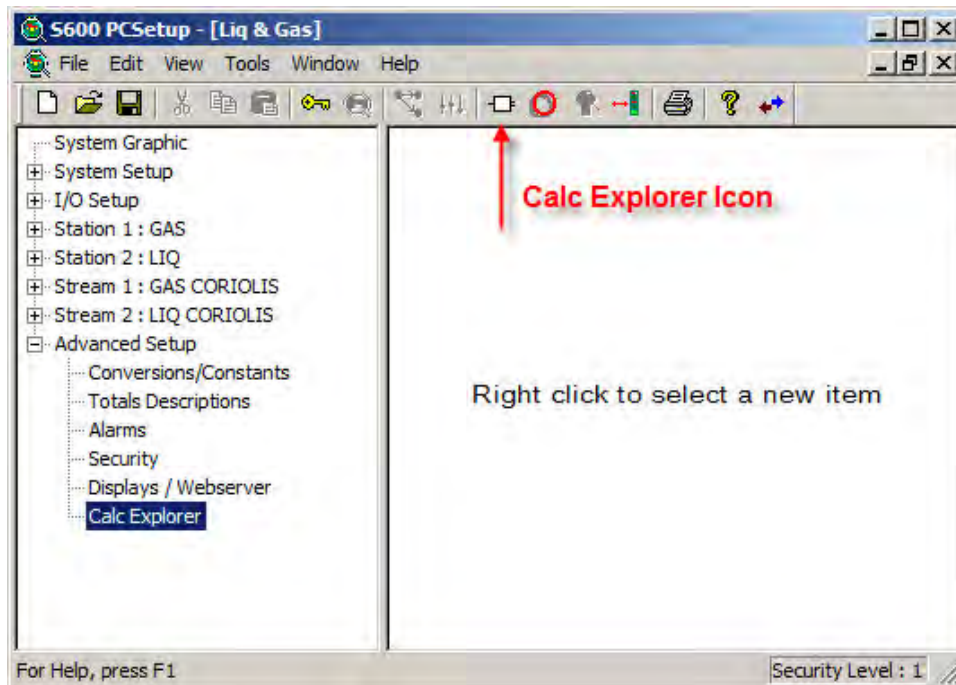

Figure 7-14. Calc Explorer (blank)

2. Right-click in the right-hand panel to display a menu of Calc Explorer options.

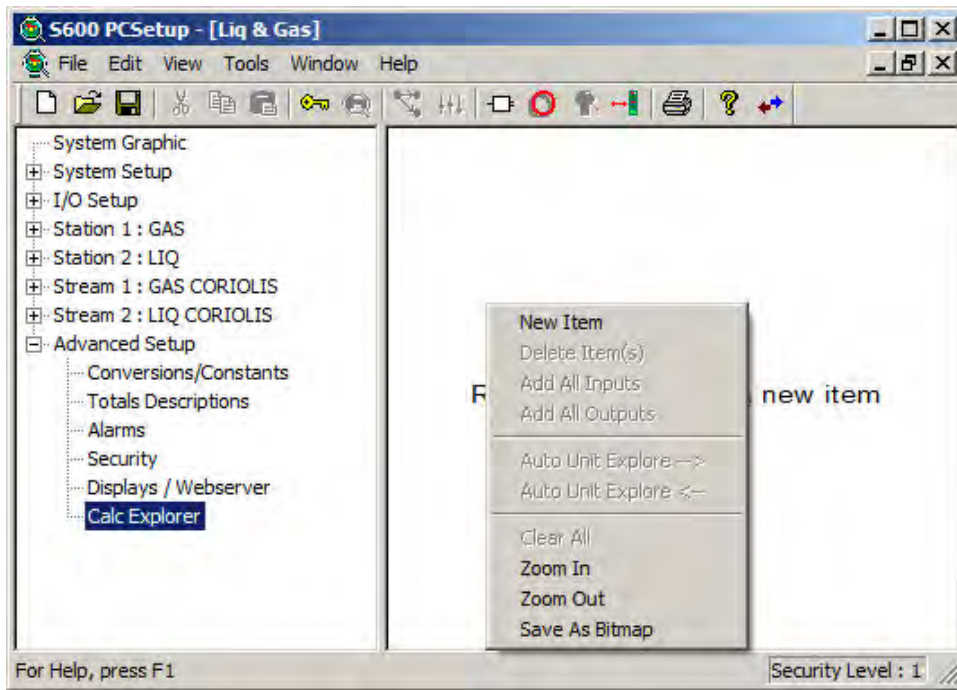

Figure 7-15. Calc Explorer menu

### 7.6.1 Calc Explorer Options

Once you add an item and right-click on it, the system displays a menu of Calc Explorer options. The following table describes the all options on that menu.

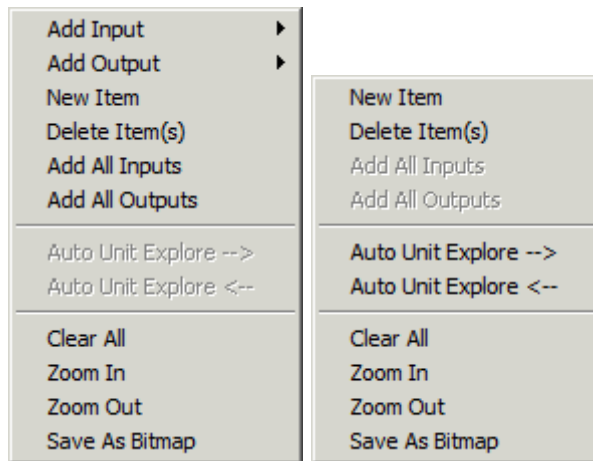

Figure 7-16. Calc Explorer Menu Options

**Note:** This menu modifies its content to reflect the available inputs or outputs of any item you select.

Option	Description
<b>Add Input</b>	Displays a list of all defined inputs for the selected item. You can add inputs individually. <b>Note:</b> This menu option displays <b>only</b> if the selected item has defined inputs.

<b>Option</b>	<b>Description</b>
<b>Add Output</b>	Displays a list of all defined outputs for the selected item. You can add outputs individually. <b>Note:</b> This menu option displays <b>only</b> if the selected item has defined outputs.
<b>New Item</b>	Displays a Connect Wizard dialog box you use to add system components ("items") to the Calc Explorer graphic.
<b>Delete Item(s)</b>	Removes the selected item from the Calc Explorer graphic. <b>Note:</b> To select more than one item, place the cursor in a blank area of the screen. Click and hold down the left mouse button while dragging the cursor. This creates a box. Drag the box over one or more items. Note that their border becomes a dashed line, indicating you have selected them. Release the right mouse button and left-click any selected item to display the menu.
<b>Add All Inputs</b>	Adds <b>all</b> inputs related to the selected item to the Calc Explorer graphic. <b>Note:</b> This option is grayed out if the selected item <b>does not</b> have defined inputs.
<b>Add All Outputs</b>	Adds <b>all</b> outputs related to the selected item to the Calc Explorer graphic. <b>Note:</b> This option is grayed out if the selected item <b>does not</b> have defined outputs.
<b>Auto Unit Explore --&gt;</b>	Locates and displays calculations where an input to a calculation matches the inputs of the selected item. <b>Note:</b> This menu option displays <b>only</b> if the selected item has units.
<b>Auto Unit Explore &lt;--</b>	Locates and displays outputs of calculations that match the units of the selected item. <b>Note:</b> This menu option displays <b>only</b> if the selected item has units.
<b>Clear All</b>	Removes all items from the Calc Explorer graphic.
<b>Zoom In</b>	Reduces the Calc Explorer graphic to its default display size.
<b>Zoom Out</b>	Magnifies the Calc Explorer graphic.
<b>Save As Bitmap</b>	Saves the displayed Calc Explorer graphic as a bitmap (CalcExplorer.bmp) in the folder housing the Config600 software. <b>Note:</b> Config600 uses the same name for each bitmap. To save bitmaps of several configurations, you must uniquely rename each bitmap.

## 7.6.2 Adding an Item

Use this procedure to add a new item to the Calc Explorer screen.

1. Click **New Item** on the menu. The Connect Wizard displays.

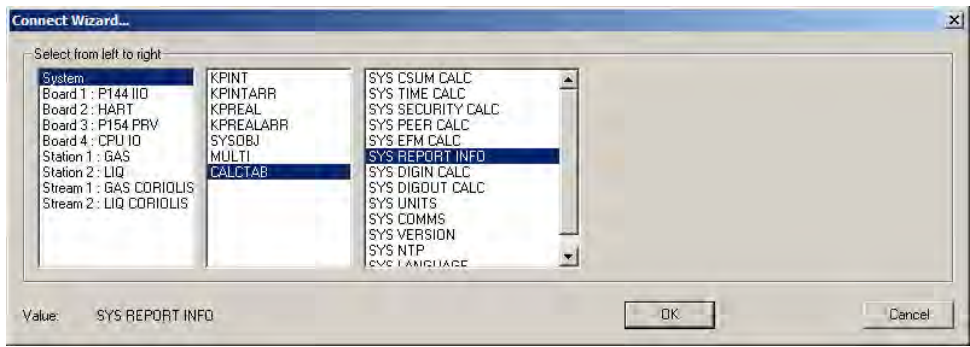

Figure 7-17. Connect Wizard

2. Select an option from each of the three columns and click **OK**. Calc Explorer adds the defined item to the screen.

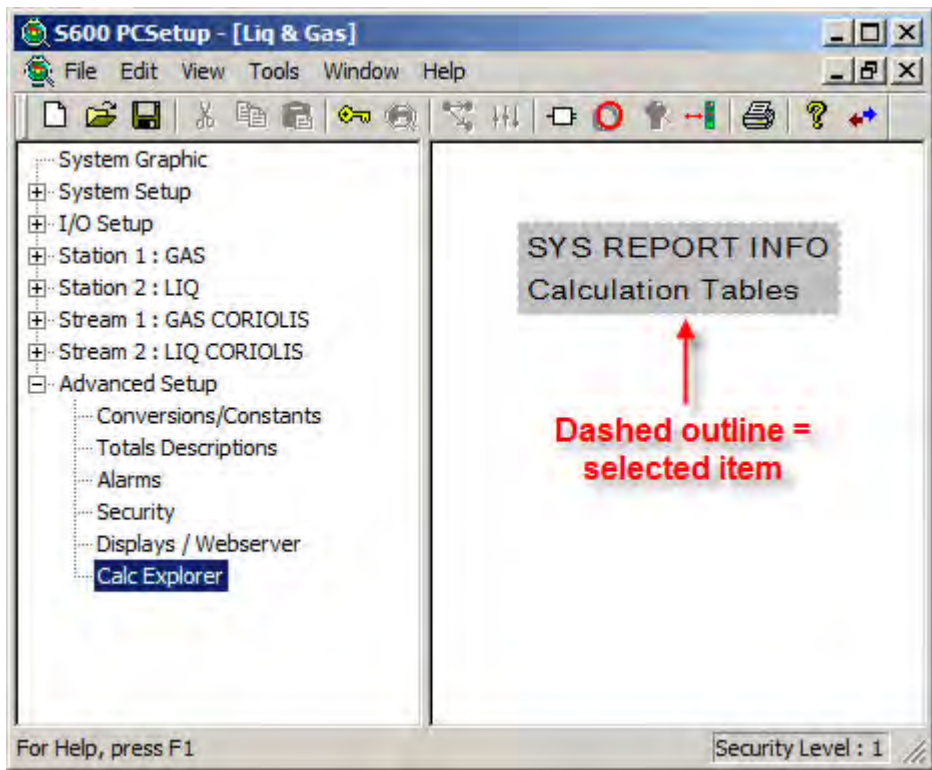

Figure 7-18. Newly Added Item

**Notes:**

- When you first add an item, Calc Explorer gives it a dashed (not solid) outline (see Figure 7-18). This indicates that the item is currently selected. When you right-click a selected item, the Calc Explorer menu displays for that item. When you add a second item, that item receives the dashed outline. The previous item now has a solid outline, indicating it is no longer selected.
- You can move any item on the graphic to any location. Place the cursor over the item, hold down the left-click button, and drag the item to its new location. This enables you to organize the items you place on the Calc Explorer screen.



### 7.6.3 Adding All Inputs

Use this option to add **all** defined inputs for the selected item to the Calc Explorer screen.

1. Right-click an item to display the Calc Explorer menu.

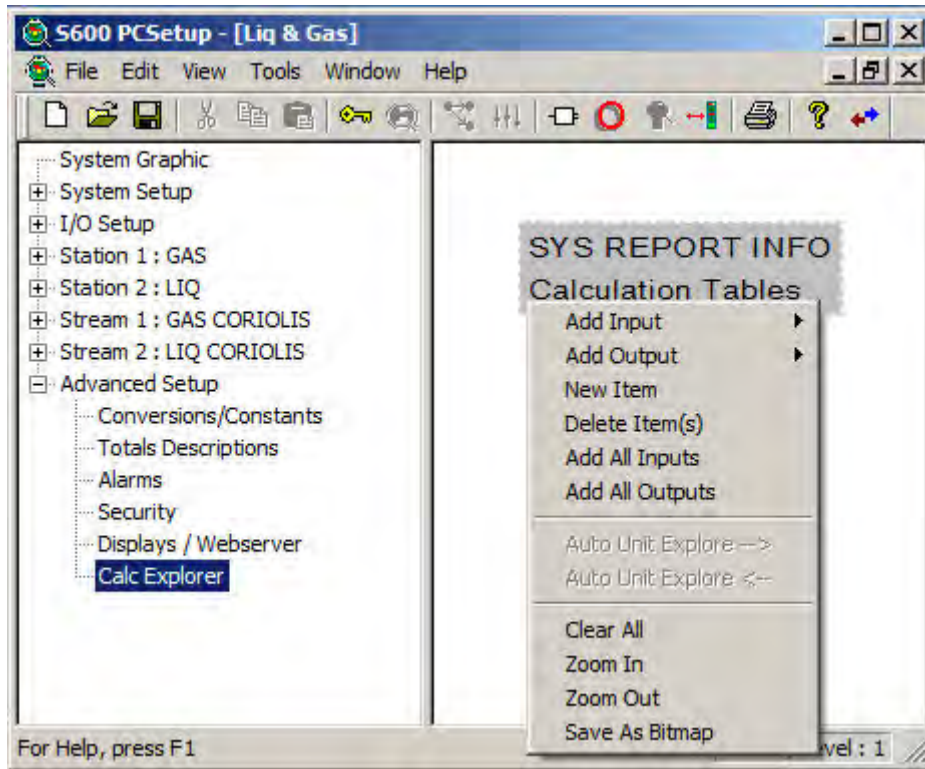

Figure 7-19. Adding Inputs

2. Click **Add All Inputs**. The Calc Explorer displays all inputs for the selected item.

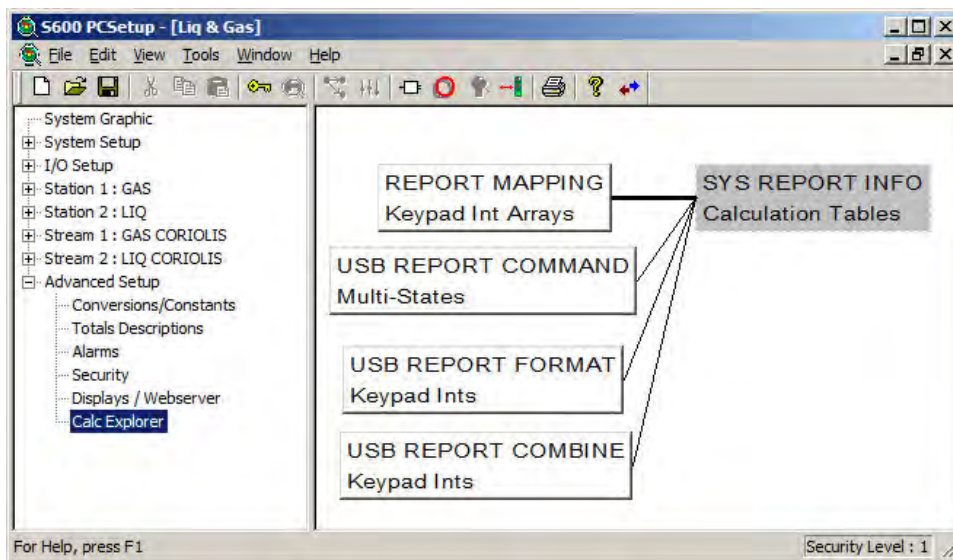

Figure 7-20. Added Inputs

**Notes:**

- Use the **Add Input** menu option to add individual inputs to the screen.
- Shaded (or gray) items indicate calculation tables. Unshaded (or white) items indicate inputs or outputs.
- A thick line connecting items indicates that the item has many values (such as arrays).

### 7.6.4 Adding All Outputs

Use this option to add **all** defined outputs for the selected item to the Calc Explorer graphic.

1. **Right-click** an item to display the Calc Explorer menu.

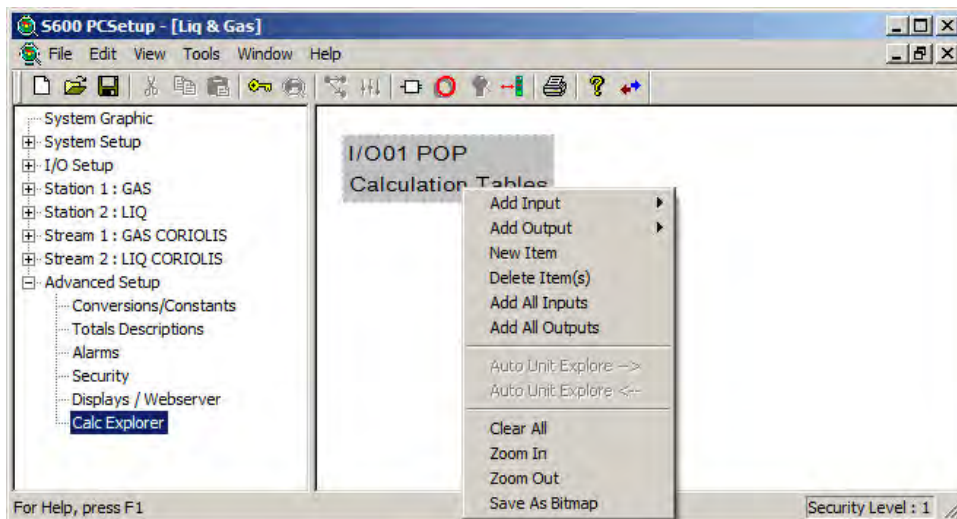

*Figure 7-21. Adding Outputs*

2. Click **Add All Outputs**. The Calc Explorer displays all outputs for the selected item.

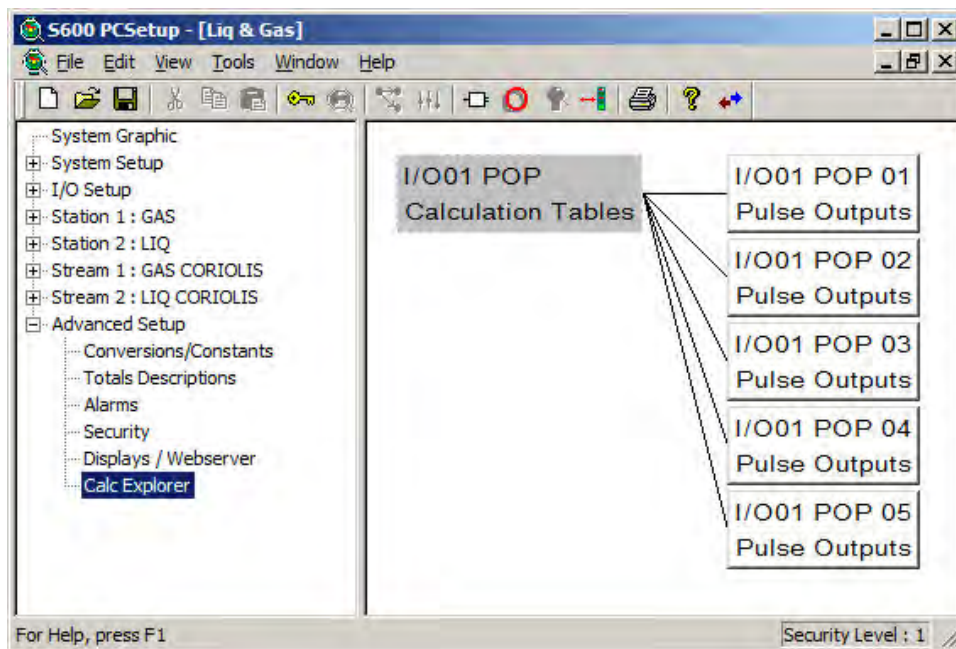

Figure 7-22. Added Outputs

---

**Note:** Use the **Add Output** menu option to add individual outputs to the screen.

---

### 7.6.5 Deleting Items

Use this option to remove one or more selected items from the Calc Explorer screen.

---

**Note:** Calc Explorer does not have an “undo” feature. Once you delete an item, you can only re-add it.

---

1. **Right-click** an item to select it and display the menu.
2. Click **Delete Item(s)**. The menu closes and the item disappears from the screen.

To delete more than one item:

1. Move the cursor in a blank area of the screen near the items you intend to delete.
2. Click and hold down the left mouse button while dragging the cursor. This creates a box.
3. Drag the box over one or more items. Note that as the box touches any item, the border of that item becomes a dashed line, indicating you have selected that item.
4. Release the right mouse button and left-click any of the selected items to display the menu.
5. Click **Delete Item(s)** to delete all of the selected items.

---

**Note:** Use the **Clear All** menu option to remove all items from the Calc Explorer screen.

---

## 7.6.6 Saving as Bitmaps

Use this option to save the current contents of the Calc Explorer screen as a bitmap (.BMP) graphic on your PC's hard drive.

Config600 saves the bitmap (as the file CalcExplorer.bmp) in the directory in which you have installed the Config600 software. If you intend to create bitmaps of several images, rename the CalcExplorer.bmp file **immediately** after you capture the image. Otherwise Config600 reuses the CalcExplorer.bmp filename and overwrites the most recent file.

1. **Right-click** in the screen to display the Calc Explorer menu.

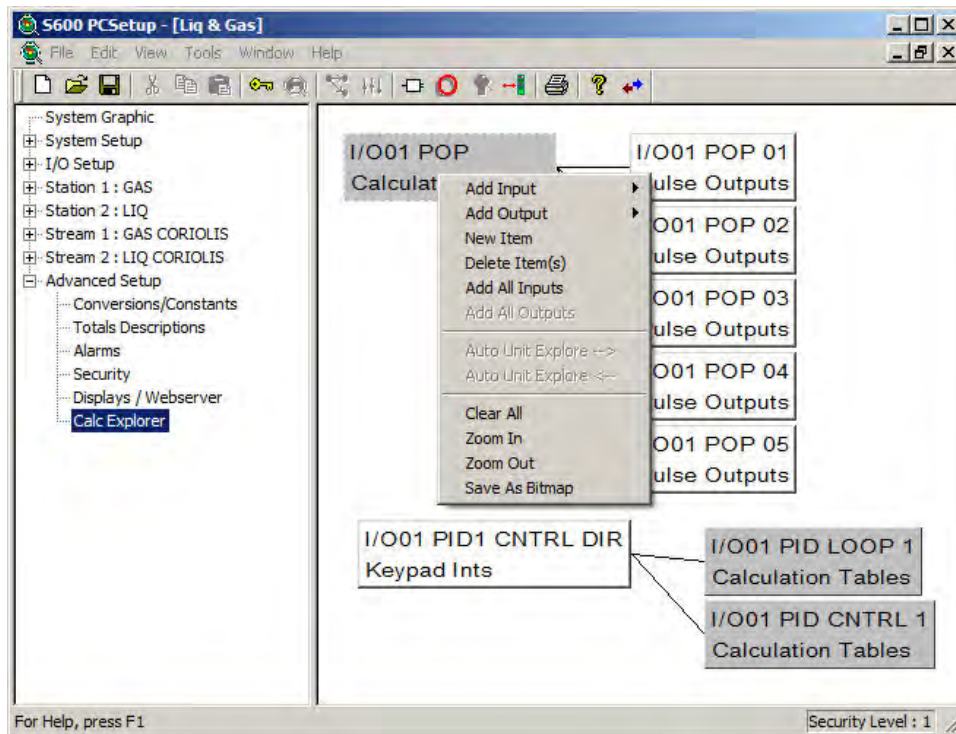

Figure 7-23. Saving a Bitmap

---

**Note:** Depending on the complexity and size of your Calc Explorer image, you may want to maximize the screen size.

---

2. Click **Save As Bitmap**. The Calc Explorer menu closes and the saves the bitmap image on your PC's hard drive.

## Chapter 8 – System Editor

### In This Chapter

8.1	Accessing the System Editor.....	8-2
8.2	The S600+ Database.....	8-3
	8.2.1 Objects.....	8-4
	8.2.2 Tables.....	8-5
8.3	Navigating the System Editor.....	8-5
	8.3.1 Finding Objects.....	8-6
	8.3.2 The System Editor Icon Bar.....	8-6
	8.3.3 Special Edit.....	8-7
	8.3.4 Edit Dialog.....	8-8
	8.3.5 Asterisks/No Asterisks.....	8-9
8.4	General Guidelines.....	8-10

---

**Note:** This editor is available **only** with the Config600 Pro software.

---

The System Editor enables you to configure the S600+ database. Just as the PCSetup Editor provides a guided interface for editing data points in a configuration, the System Editor enables the advanced user to create and modify data points. Using the System Editor, you can create, remove, or change database objects and tables.



#### Caution

**This chapter is intended for use in conjunction with materials from the RA901 Advanced Config600 training course. That training is critical to understanding the concepts in this chapter. Unless you have completed that training, do not attempt to use the material in this chapter as a sole means of learning about the System Editor.**

---

The System Editor does not have a Configuration Generator. Instead, use the System Editor to edit existing configurations. Through the System Editor, you can:

- Change units.
  - Change report information.
  - Change I/O.
  - Change communications tasks and links.
  - Enable and disable alarms.
  - Configure alarms object by object.
  - Change cold start values (for example, densitometer constants).
  - Change descriptors.
  - Configure existing calculations.
  - Create and delete calculations.
  - Change passwords.
  - Create and delete database objects.
-

## 8.1 Accessing the System Editor

Use this process to open and select a configuration file to edit.



1. Select **Start > Programs > Config600 3.3 > System Editor**. A blank System Editor screen displays.

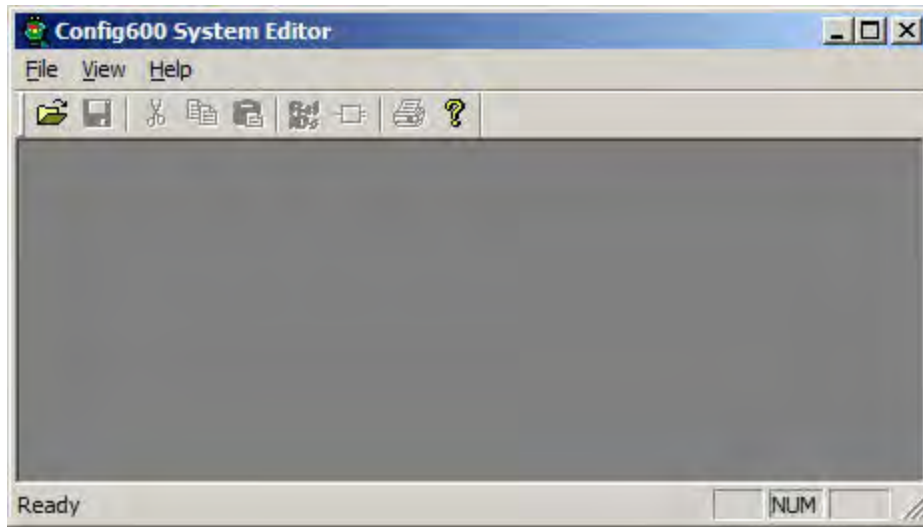

Figure 8-1. System Editor screen (blank)

**Note:** You can also define a shortcut for your desktop to easily access this application.

2. Select a specific configuration file. From the menu bar, select **File > Open**. The Open dialog box displays.

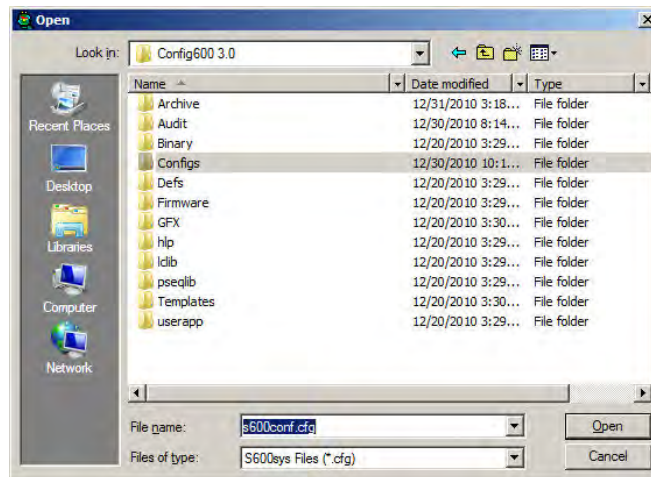

Figure 8-2. Open dialog box

3. Open the **Configs** folder (in which Config600 stores all configuration files) and click **Open**.
4. Select the name of a configuration file to edit and click **Open**. Config600 opens another dialog box that shows the contents of that folder.



Figure 8-3. Open Dialog box (with .cfg file)

5. Double-click the S600conf.cfg file.

---

**Note:** You must provide a username and password if the configuration file has password protection.

---

6. Once you select a configuration (.CFG) file, the System Editor opens:

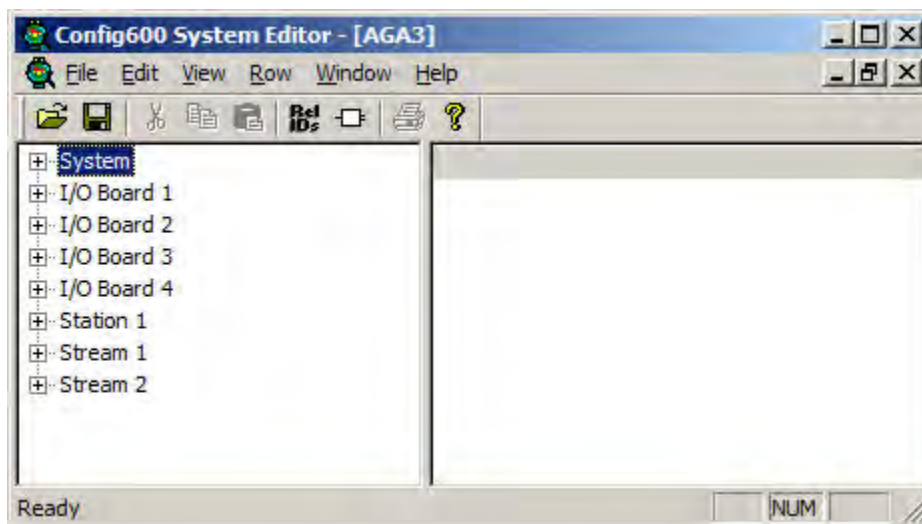

Figure 8-4. System Editor screen (loaded)

## 8.2 The S600+ Database

The S600+ database is divided into sections. Each section contains a selection of available data types. Within the sections, the database item locations are numbered:

- System.

- I/O Boards 1 to 7.
- Stations 1 and 2.
- Streams 1 to 10.



**Caution**

If you add any new objects to the database, the System Editor automatically re-indexes the Modbus map, displays, and reports. However, the System Editor does not re-index any LogiCalc programs, which may cause LogiCalc programs to stop functioning.

**Note:** For further information about the structure of the database, refer to *Chapter 12, Report Editor*.

## 8.2.1 Objects

The S600+ database contains **objects** and **tables**. The following list identifies the objects in the S600+database. Your configuration may or may not contain all these objects, depending on your application.

- Cumulative Totals.
- Period Totals.
- Analog Inputs.
- PRT/RTD Inputs.
- Pulse Inputs.
- Frequency Inputs.
- Digital I/Os.
- Analog Outputs.
- Pulse Outputs.
- Keypad Integers.
- Keypad Integer Arrays.
- Keypad Reals.
- Keypad Real Arrays.
- Keypad Strings.
- Calculation Results.
- Configuration Items.
- System Objects.
- DP Stacks.
- PID Control Loops.
- Alarm Items.
- Multi-States.
- Prove Controls.
- Array Texts.
- HART Devices.
- Event History.
- Alarm History.

Some objects can be associated with tables. For example, the ‘VALUE’ of a keypad integer can be linked to a text string. See the example below for the Calculation Alarm object. The Mod\_Tab\_id object is associated with Mode Table #3 (Calculated or Keypad).

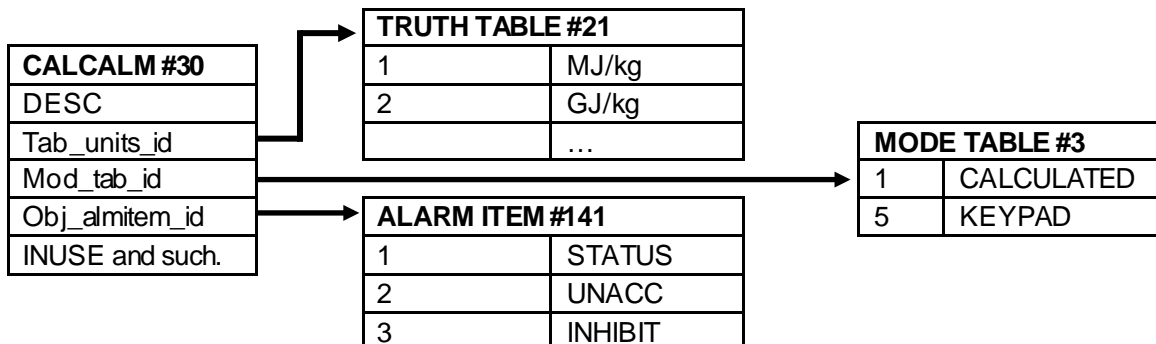

Figure 8-5. Object/Table Relationship



## 8.2.2 Tables

Tables map an integer to a text string. For example, when describing AGA8 calculations, you can link the options Detail, Gross 1 and Gross 2 by a Truth table to the integers 0, 1, and 2, respectively. The database can then use the integer value and refer back to the Truth table for its meaning.

The following list presents some of the tables in the S600+ database. Your configuration may or may not contain all these tables, depending on your application.

- Turbine Meter Setup.
- Digital Input.
- Totalisation.
- Task Control.
- Digital Output.
- Internal Index.
- Mode Text.
- Truth Tables.
- Alarm Text.
- Calculation.
- Prover Setup.
- Password.
- I/O Assignment.
- HART.

## 8.3 Navigating the System Editor

The System Editor splits the S600+ database into four categories:

- System.
- I/O Boards.
- Stations.
- Streams.

Depending on the system configuration, you may have multiple I/Os, Stations, and Streams.

You access these four database categories through the hierarchy menu, presented in the window's left-hand pane. As with the PCSetup Editor, the System Editor window consists of two panes. Clicking on an item in the hierarchy menu in the left-hand pane displays a screen in the right-hand pane.

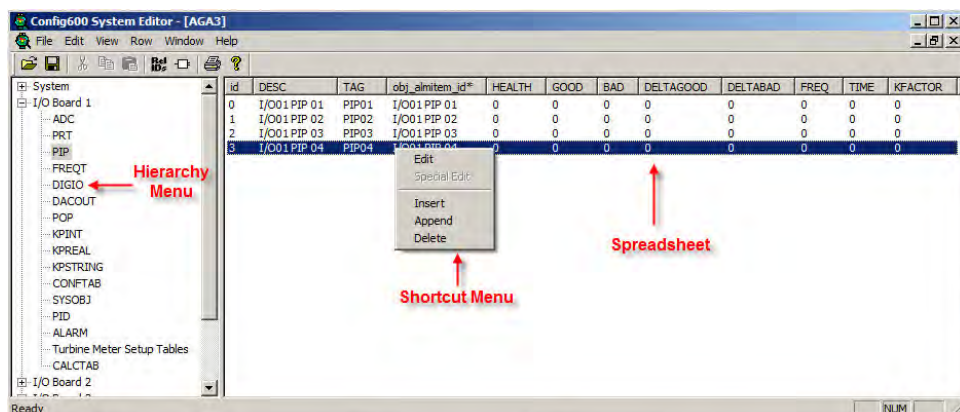

Figure 8-6. System Editor screen

Unique to the System Editor is its “spreadsheet-style” presentation of the right-hand pane. Each object and table has its own spreadsheet screen with headings appropriate to that object or table. Right-clicking on a line in the right-hand pane displays a shortcut menu with the options **Edit**, **Special Edit** (for calculation tables only), **Insert** (insert above), **Append** (insert below), and **Delete**. Use these menu functions to manage the object or table information.

Each line in the right-hand pane presents one object or table entry. The spreadsheet headings indicate the number (ID), the descriptor (DESC), and several parameters for that specific object or table entry.







### 8.3.1 Finding Objects

Finding objects in the System Editor requires that you think about **what** the object is.

For example, if you are looking for Analog Channel 3, first determine on which I/O board the channel is located (in this example, I/O Board 1). Expand the I/O Board 1 option in the hierarchy menu and highlight ADC. Alternately, if you are looking for the Pipe Material data item, realize that it is a Keypad Integer value. Determine the stream (Stream 1 in this example). When you expand the Stream 1 option, highlight KPINT (for this example) to find it as item ID #262.

### 8.3.2 The System Editor Icon Bar

The System Editor’s icon bar provides icons for the following actions and shortcuts:

Icon	Meaning
	<b>Open Configuration.</b> Click to open the Select Config dialog box.
	<b>Save Configuration.</b> Click to save the current configuration with the current configuration file name.
	<b>Cut, Copy and Paste.</b> These clipboard icons are available if not greyed out. Click <b>Cut</b> to remove the selection from the clipboard. Click <b>Copy</b> to store the selection to the clipboard. Click <b>Paste</b> to insert the contents of the clipboard to the cursor’s location.
	<b>Relative IDs.</b> Click to change the way the System Editor displays identification numbers. With Rel IDs <b>off</b> , the numbering shows the object’s <b>absolute reference</b> (that is, the absolute number of the object in a global list referenced from 0). With Rel IDs <b>on</b> , the list numbering becomes relative to the section you are currently displaying.  For example, the KPINTs start in the IO Board section as ID 66 (the 67th entry in the list of KPINTs). Clicking the Rel ID button changes this number to 0, since it now becomes the first entry in this section.  This icon is particularly useful in the LogiCalc Editor. LogiCalc referencing is relatively-based, so KPINT 66 displays as I/O Board 1, Rel ID 0.
	<b>Calc Explorer.</b> Click to open the Calc Explorer utility, and graphically examine calculation relationships between system components.
	<b>Print.</b> Click to open the Print dialog box. Use this icon to print an entire configuration to a host printer.

Icon	Meaning
	<b>About.</b> Click to open the About Config600 dialog box that lists the software version and copyright information.

### 8.3.3 Special Edit

The Special Edit dialog box for calculation tables allows you to edit an existing calculation or build a new calculation. You can configure the calculation’s description, sources (Inputs), type, and destinations (Outputs).

To access this dialog box, double-click the Calculation table or right-click the **Special Edit** option on the shortcut menu (*Figure 8-6*). The Calc Editor dialog box displays (see *Figure 8-7*).

To switch from inputs settings to outputs settings, click the  button (located below the word “Inputs” or the word “Outputs” on the Calc Editor screen, *Figure 8-7*). For each source or destination in the calculation, you can edit the Description, select the Type, assign it to an Object, enter a Field, and enter a Bit No. These all correspond to the Spreadsheet style headings for the calculation table screen.

You can also add and delete sources and destinations.



**Caution**

**The Calc Editor does not have an Undo feature. If you mistakenly delete a source or destination, you must manually re-create it.**

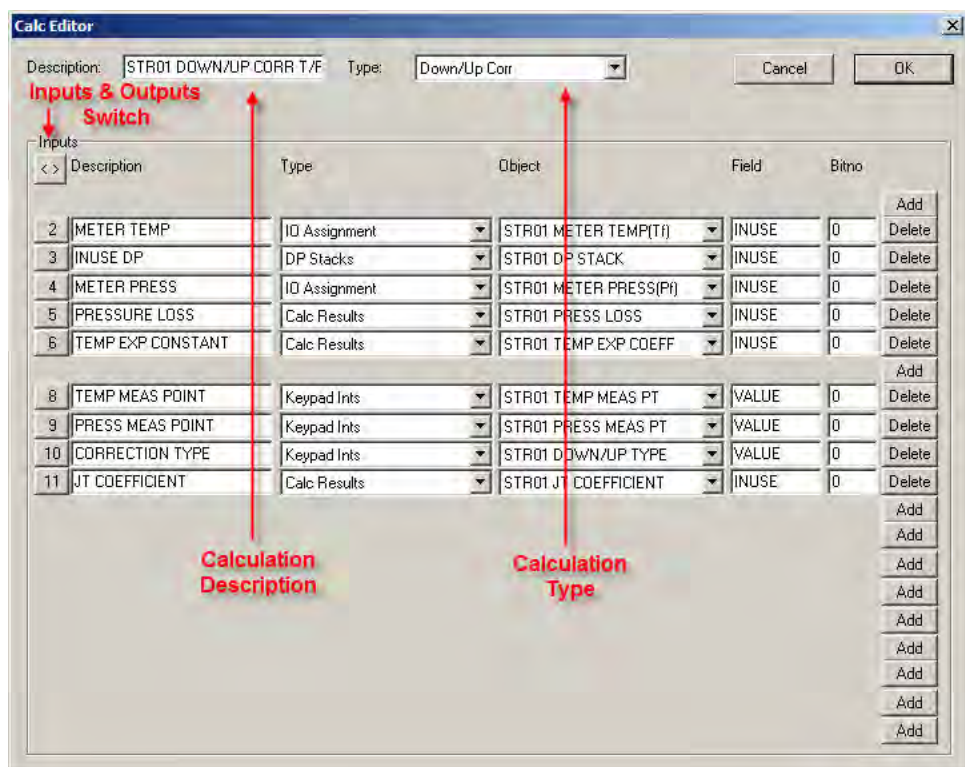

Figure 8-7. Calc Editor dialog box

To add a new input/output calculation:

1. Click **Add** (on the right-hand side of the dialog box). The Calc Editor screen adds a new numbered line under Inputs or Outputs.

---

**Note:** To edit an **existing** calculation, skip step 1 and click the number of the line.

---

2. Click the number for the new line. The Connect Wizard displays.

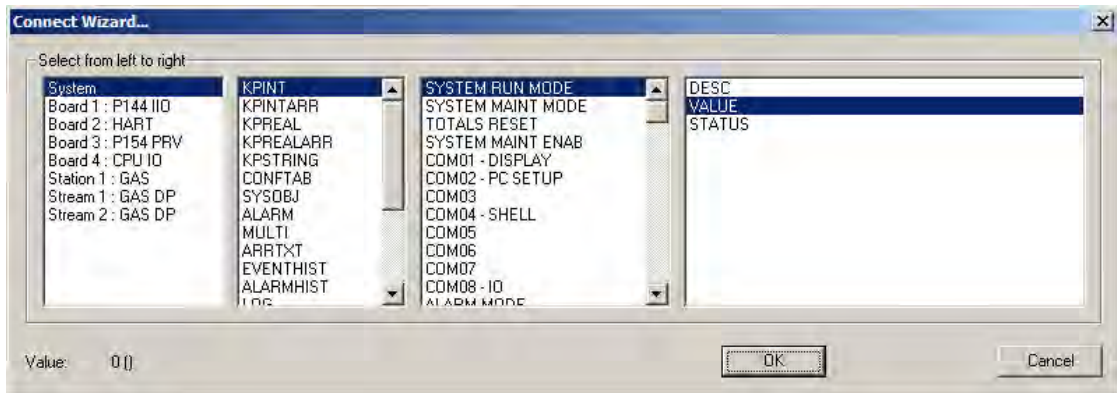

Figure 8-8. Connect Wizard

---

**Note:** Although you can individually select calculation components on the Calc Editor dialog box, using the Connect Wizard is the **safest**—and **most accurate**—way of selecting calculation components.

---

3. Select, from left to right, the calculations components.
4. Click **OK** when you are done. The Calc Editor dialog box redisplay, showing the newly defined calculation line.

### 8.3.4 Edit Dialog

When you select **Edit** from the shortcut menu, the Edit dialog box appears. Use it to edit or create a new row in the spreadsheet-style screen or to configure the data point, text string, or value in each column of the spreadsheet-style screen.

The Columns field lists the headings for this object/table's screen. Clicking on a heading from this list displays the Data fields for that object or table. The Data (ID:,Col:) field in the upper right corner provides the location in the spreadsheet for this data point. The Data field shows the current assignment for the heading highlighted in the Columns field.

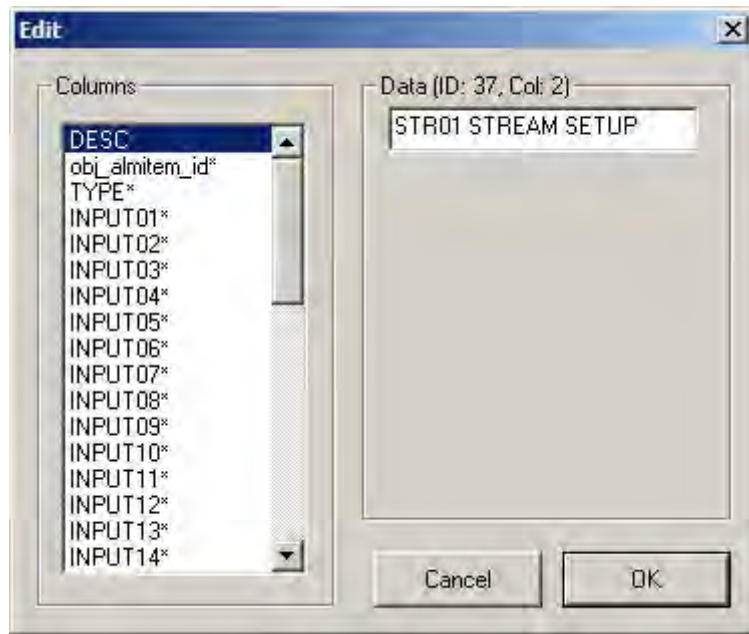
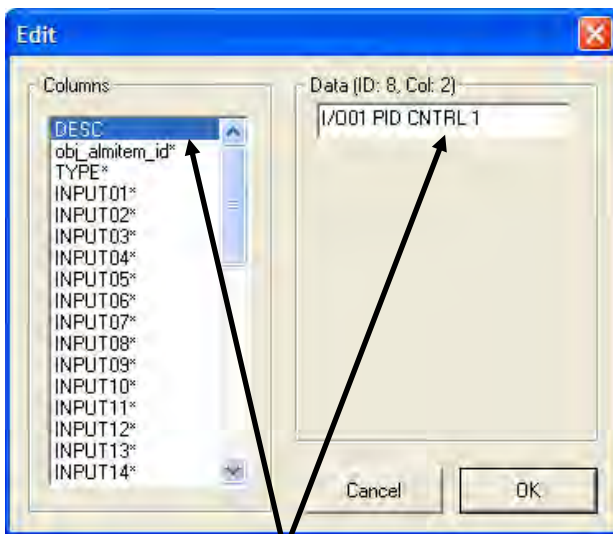

Figure 8-9. Edit Dialog (System Editor)

### 8.3.5 Asterisks/No Asterisks

If the heading displayed in the Columns listing is appropriate for entering integer values or text strings, then the heading in the Columns list **does not** have a trailing asterisk, and a field appears in the Data area for data entry of the integer value or text.

If the heading has options from a pre-defined list, then the heading in the Columns list **has** a trailing asterisk. Additionally, a list displays under the Data field. You can select a value from the list either by clicking with a mouse or by entering the item's number that appears in the Data field.



No Trailing Asterisk

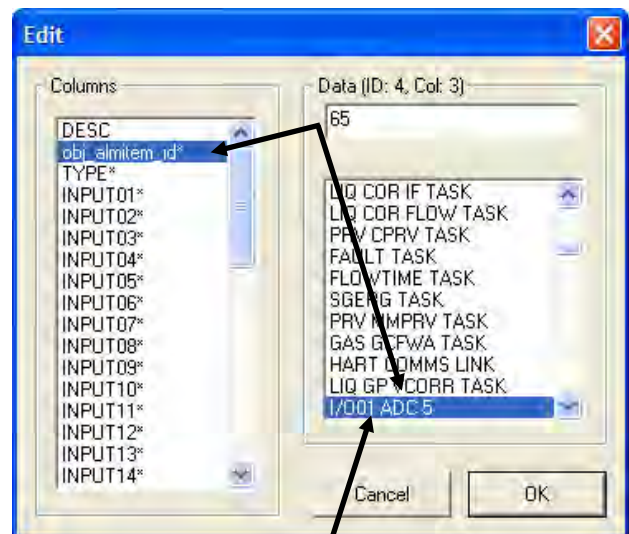

Trailing Asterisk

Figure 8-10. Edit dialog box

## 8.4 General Guidelines

---

Observe the following guidelines with the System Editor:

- The **File > Save** and **File > Save As** options have the same function in this editor. You can use them interchangeably.
- Assign the Measured and Calculated (R/O) data points a security level of 0 so that only the input source, the PC, or the S600+ processor can write to them.
- Exercise **great** caution when inserting or deleting information. The System Editor does not have an Undo function. You cannot restore deletions.
- Save your work every few minutes. If you inadvertently delete or modify a configuration file, you can restore by closing without saving. Re-open with the last save, thereby losing only a few modifications.
- S600+ displays the description for each data point on the S600+ front panel display and web server access. Whenever possible, type descriptions for each data point in upper case letters (CAPS). Upper-case text (CAPS) is easier to read on the front panel display.

## Chapter 9 – Config Transfer

### In This Chapter

9.1	Connecting TO THE S600+.....	9-2
9.1.1	Connecting via Serial Cable.....	9-2
9.1.2	Connecting via TCP/IP.....	9-2
9.1.3	Enabling the PC Setup Link.....	9-2
9.1.4	Checksum Security.....	9-3
9.2	Accessing Config Transfer.....	9-3
9.3	Communications Settings for Transfer.....	9-4
9.3.1	Setting Communication Parameters.....	9-4
9.4	Send Configuration.....	9-6
9.4.1	Sending a Configuration.....	9-6
9.4.2	Manually Adding a Configuration File to be Transferred.....	9-7
9.5	Receive Configuration.....	9-8
9.5.1	Receiving a Configuration.....	9-8
9.6	Log Transfers.....	9-9
9.6.1	Logging a Transfer.....	9-9
9.7	CFX Licensing.....	9-10
9.7.1	Transferring a License.....	9-10
9.7.2	Removing a License.....	9-12



Use the Configuration Transfer (Config Transfer) utility to send new or modified configuration files to the S600+ over either a dedicated serial port or a TCP/IP connection. Config Transfer also enables you to retrieve configuration files from the host PC to the S600+.

**WARNING:** Performing configuration changes while equipment is operating may result in unexpected behavior. Take appropriate action to prevent impact to field devices.

Config600 saves configuration files in the Configs directory on the host PC, and automatically creates a separate sub-directory for each new configuration. Config600 also places the following additional components in separate sub-directories:

**Note:** You can also access this utility either by selecting **Tools > Transfer** from the PCSetup menu bar or by selecting **Start > Config600 3.3 > Config Transfer**.

- **Reports** (report format files)
- **Modbus** (Modbus configuration files)
- **Override** (custom files, such as customized versions of the displays, reports, and Modbus files)

**Note:** Config600 uses this folder only for older existing configurations. Config600 does not use the Override folder for new configurations.

- **LogiCalcs** (custom-written files that permit the creation of user-defined functions)
- **Extras** (user-defined look-up tables and configuration backup files)

- **Logs** (copies of logs created during wizard generation / backup synchronisation)

Config Transfer also provides a utility that enables you to license Config600

## 9.1 Connecting to the S600+

---

You can connect to the S600+ using either a serial cable or a TCP/IP connection.

### 9.1.1 Connecting via Serial Cable

The S600+ comes with a serial cable you can use to connect your PC to the S600+. One end of the cable has a DB-9 female connector, which you attach to your PC's serial port. The other end of the cable has two connectors, a male DB-15 (for serial connection) and an RJ-12 (EIA-232/RS-232D). Alternately, you can insert the RJ-12 connector into the port on the bottom of the S600+ flow computer's front panel.

### 9.1.2 Connecting via TCP/IP

You can connect to the S600+ using an Ethernet cable. In this case, you must first define an IP, subnet, and gateway addresses for your S600+. Refer to the *FloBoss™ S600+ Flow Computer Instruction Manual* Form Number A6115.

### 9.1.3 Enabling the PC Setup Link

Regardless of the connection method you use, the S600+ (by default) does not allow you to download or upload configurations or license applications until you either access the Startup menu (refer to the *FloBoss™ S600+ Flow Computer Instruction Manual* Form Number A6115) or enable the PC Setup link from the S600+. If you proceed without enabling the PC Setup link, Config600 displays a warning dialog:

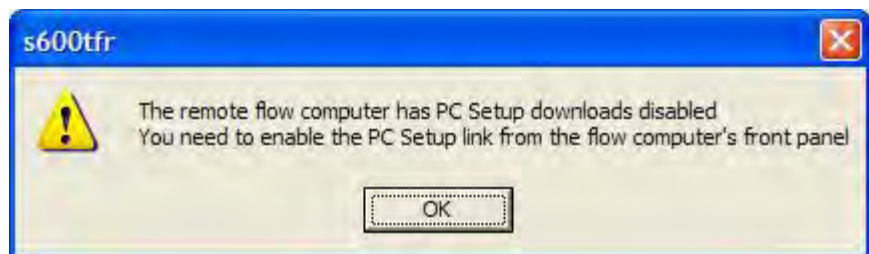

Figure 9-1. PCSetup Error Message

To enable the PC Setup link:

1. From the S600+ front panel's main menu, select **TECH/ENGINEER > SECURITY**.
2. Press ► to access the PC Setup Link screen, which indicates that the PC Setup Link is currently **DISABLED**.



3. Press **CHNG** and enter the security code defined for your ID.
4. Select **ENABLE** and select **ENABLE** again. The PC Setup Link screen displays, indicating that the PC Setup Link is now **ENABLED**.

### 9.1.4 Checksum Security

When you send a configuration to the S600+, it checks the configuration to ensure that it has not been modified manually. Config600 calculates and applies a checksum value on the file. If the checksum value the S600+ detects does not match the Config600-applied checksum value, the S600+ displays a warning message.

If the error persists after repeating the configuration download, it may be possible to resolve the warning and repair the configuration checksum. Use a registered copy of Config600 and login with the Level 1 Username and Password. Once you have correctly entered the Username and Password, Config600 saves the configuration file with the correct checksum.

## 9.2 Accessing Config Transfer

You can start Config Transfer using any one of three methods:

- Click the Transfer icon  on the PCSetup Editor's toolbar.
- Select **Tools > Transfer** from the PCSetup Editor's menu bar.
- Click **Start > All Programs > Config600 3.3 > Config Transfer**.

The Config Transfer screen displays.

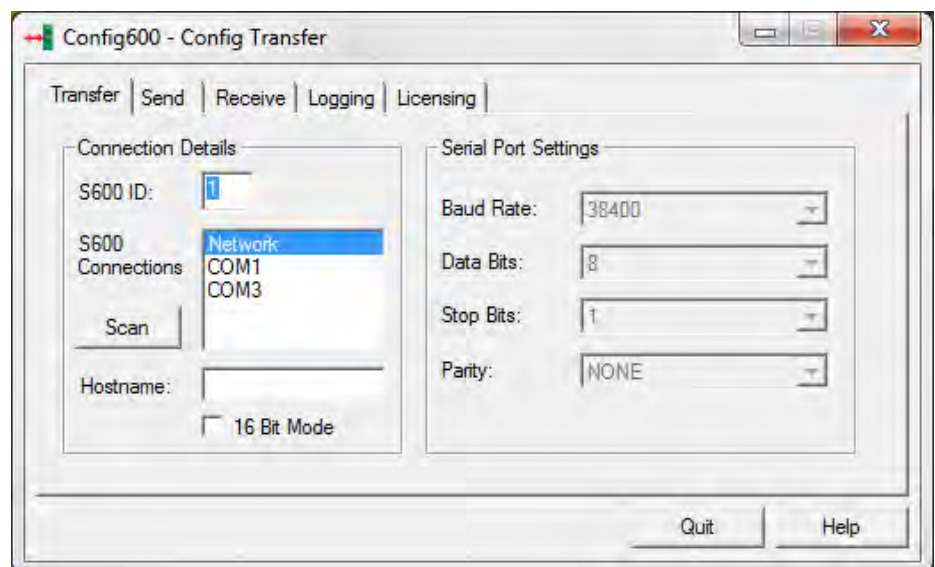

Figure 9-2. Config Transfer screen

This screen uses a tab design to present the major components—Transfer, Send, Receive, and Logging—of the transfer process, as well as to include software licensing (Licensing).

Tab	Description
-----	-------------

Tab	Description
<b>Transfer</b>	Sets the communication parameters between the S600+ and the PC.
<b>Send</b>	Identifies the configuration file you want to send from the PC to the S600+.
<b>Receive</b>	Identifies the configuration file you want to retrieve from the S600+.
<b>Logging</b>	Activates logging for the transfer process and selects the select of detail included in the log.
<b>Licensing</b>	Enables you to transfer a license from a secure USB drive ("dongle") to Config600.

### 9.3 Communications Settings for Transfer

The host PC uses a dedicated serial or Ethernet port to connect to the S600+, and transfers data in accordance with the communication settings defined for that communications port.

**Notes:**

- Both the host PC and the S600+ must use the same communications settings for data to transfer successfully.
- If you are downloading a configuration via Ethernet, disable any communication links from a device that is communicating with the S600+ **before** attempting to download the configuration as this may disrupt the confirmation upload/download.

#### 9.3.1 Setting Communication Parameters

The Transfer screen displays when you first open the utility.

**Note:** Both the S600+ and the host PC must have the same communications settings to communicate successfully.

1. Start the Config Transfer utility.
2. Select the **Transfer** tab.
3. Enter the Modbus address for the S600+ in the **S600 ID** field.

This value is available from the S600+ front panel (select **Tech/Engineer > Communications > Assignment > Modbus Address**) or from the **Network** option on the Cold Start menu.

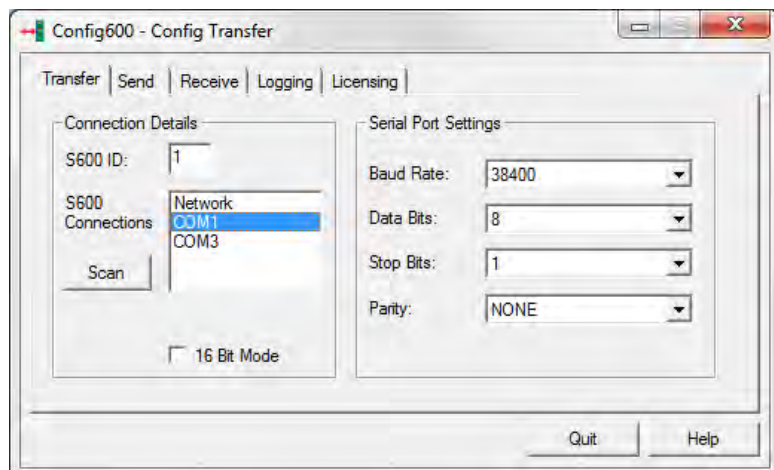

Figure 9-3. Config Transfer screen

- Indicate the specific serial or network (Ethernet) COM port in the **S600 Connections** field.

---

**Note:** To verify the serial connection, click **Scan** to display the current serial port connected to the S600+.

---

- If you are using a serial port, review the following fields. Change the default values **only** if you have a good reason for doing so.

Field	Description
<b>S600 ID</b>	Identifies the S600+; the default value is 1. You can verify the S600+ ID from the front panel of the S600+ by selecting <b>Tech/Engineer &gt; Communications &gt; Assignment &gt; Modbus Address</b> .
<b>S600 Connections</b>	Lists all available communication connections.
<b>Scan</b>	Click to validate the currently available IP or serial connections. If you have a valid network connection, the system detects it and automatically completes the Hostname field with an IP address. If you have a valid serial connection, the system detects it and automatically completes the serial port settings.
<b>Hostname</b>	Indicates the IP address of the host PC. <b>Note:</b> This field is available <b>only</b> if you selected a network connection.
<b>16 Bit Mode</b>	Provides compatibility with legacy Modbus configurations. <b>Note:</b> The 16 Bit Mode checkbox represents an advanced Modbus option. It permits a 16-bit byte count on Modbus communications, allowing longer messages. Refer to Chapter 14, <i>Modbus Editor</i> , for further information. For most systems, this option should be unchecked.
<b>Baud Rate</b>	Indicates the serial transfer rate. Click ▼ to display all valid values. The default value is <b>38400</b> . <b>Note:</b> You can modify this field <b>only</b> if you select a serial port.
<b>Data Bits</b>	Indicates the number of data bits the port uses. Click ▼ to display all valid values. The default value is <b>8</b> . <b>Note:</b> You can modify this field <b>only</b> if you select a serial port.
<b>Stop Bits</b>	Indicates the period length. Click ▼ to display all valid values. The default value is <b>1</b> . <b>Note:</b> You can modify this field <b>only</b> if you select a serial port.
<b>Parity</b>	Indicates the type of parity used to detect data corruption during transmission. Click ▼ to display all valid values. The default value is <b>None</b> . <b>Note:</b> You can modify this field <b>only</b> if you select a serial port.

- If you are using a network (Ethernet) port, complete the **Hostname** field.

## 9.4 Send Configuration

---

You can send up to 20 user configuration files to the S600+ from the host PC.

---

**Note:** Although you cannot clear a configuration from a slot; you can overwrite it.

---

Each configuration may be comprised of 55 files of the following:

- **Config** – The main configuration file for the S600+ including all the initialization values.
- **Displays** – Configuration file for the display menus and data pages.
- **Reports** – Report format configuration files.
- **Modbus Maps** – Modbus configuration files, including slave register maps and master polling sequences.
- **LogiCalcs** – Custom-written files that allow creation of user-defined functions.
- **Extras** – User-defined look-up tables, configuration backup files, and prover sequence files.
- **Logs** – Copies of logs created during wizard generation / backup synchronisation.

You can use Config Transfer to download the following files (image files):

- **Binary Package** – Embedded software for the FloBoss S600+; a basic version is installed in the S600+ prior to delivery. To transfer this package, copy the binary.app file into Binary folder from Config S600+ directory.
- **Firmware** – Software firmware and embedded software for the FloBoss S600+. This is for internal Emerson use only.



### Caution

**Updating the binary or firmware file could affect the entire metering accuracy and stability of your S600+. It is strongly recommended that you update this file only under the specific instruction of technical support personnel.**

---

### 9.4.1 Sending a Configuration

---

**Note:** If you are updating the firmware or binary file (**only under the direction of technical support personnel**), you must first place the S600+ in Reflash Firmware mode. For further instructions, refer to “Reflash Firmware” in *Chapter 8, Troubleshooting*, in the *FloBoss S600 Flow Manager Instruction Manual* (part number D301150X412).

---

To send a new or modified configuration file to the S600+ from a host PC:

---

**Note:** You **must** cold-start the S600+ **before** you can send a configuration file.

---

1. Select **System Settings > System Status > CHNG > Enter valid operator code > Cold Start > Yes** to cold-start the S600+ before you send a configuration file
2. Launch **Config Transfer**.
3. Select the **Send** tab on the Config Transfer screen.

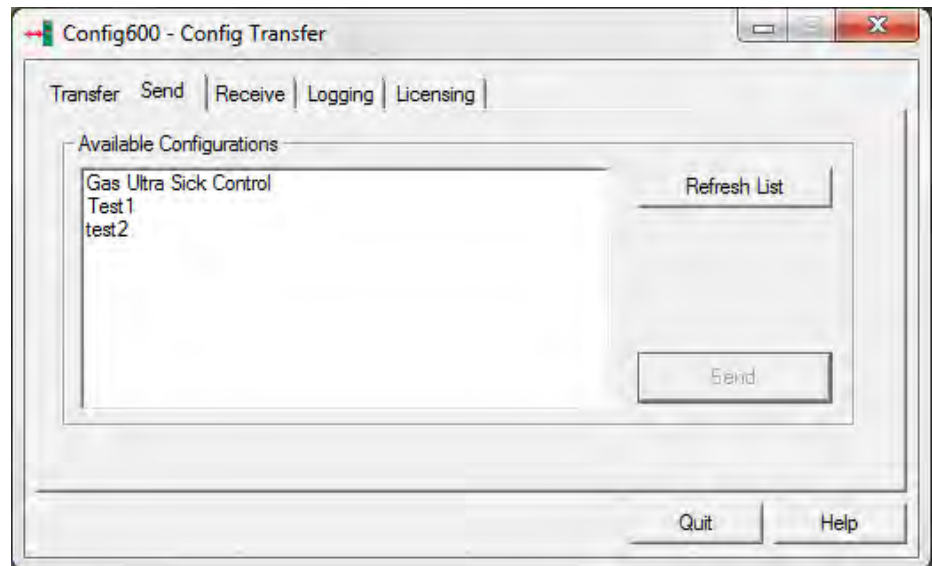

Figure 9-4. Config Transfer Send tab

4. Select a configuration from the **Available Configurations** listing.
5. Click **Send** to initiate the transfer.

A confirmation message displays when your configuration send is successful.

---

**Note:** If you are updating the firmware or binary file (under the direction of technical support personnel), you must first place the S600+ in Reflash Firmware mode. For further instructions, refer to “Reflash Firmware” in *Chapter 8, Troubleshooting*, in the *FloBoss S600 Flow Manager Instruction Manual (A6115)*.

---

## 9.4.2 Manually Adding a Configuration File to be Transferred

To manually add a configuration file to the Config600 to transfer the file to the S600+ from a host PC:

1. Open the folder where you installed Config600.

---

**Note:** By default, this is in the  
C:\Users\<<USERNAME>>\Config600 3.3\Configs folder.

---

2. Copy the **configuration folder** into the **Configs** folder.

---

**Note:** All configuration files are encrypted in an archive folder.

---

## 9.5 Receive Configuration

---

You can receive the following files from the S600+ onto the host PC:

- **Config** (the main configuration file for the S600+ including all the initialization values)
- **Displays** (configuration file for the display menus and data pages).
- **Reports** (report format configuration files)
- **Modbus Maps** (Modbus configuration files, including slave register maps and master polling sequences)
- **LogiCalcs** (custom-written files that allow creation of user-defined functions)
- **Extras** (user-defined look-up tables and configuration backup files)
- **Logs** (copies of logs created during wizard generation / backup synchronisation)

### 9.5.1 Receiving a Configuration

To receive a configuration file from the S600+ into a host PC:

1. Select the **Receive** tab on the Config Transfer screen.

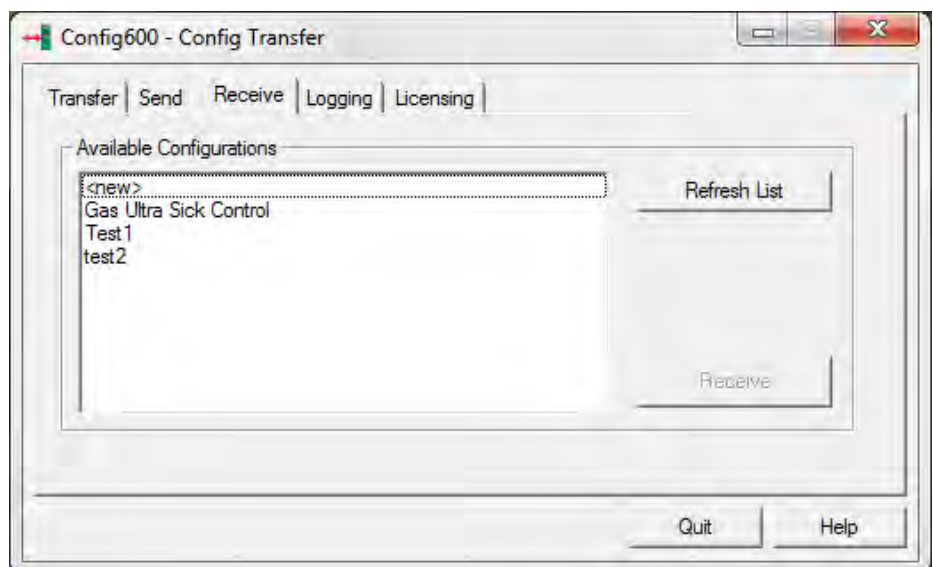

*Figure 9-5. Config Transfer Receive tab*

2. To overwrite an existing configuration, select it from the **Available Configurations** listing. You can also select **<new>** to create a new configuration on the host PC.

---

**Note:** Click **Refresh List** to update the list with the configuration files in S600+.

---

3. Click **Receive** to initiate the transfer.
4. If you selected <new>, Config600 now prompts you to **name** the folder to receive the new configuration files.



Figure 9-6. Save As New Config dialog box

5. Enter up to 30 characters to name the folder.

A confirmation message displays when your configuration receive is successful.

## 9.6 Log Transfers

You can create a log of the activity and events of the transfer application. This log can be useful for diagnosing and resolving communication problems.

When you enable the logging function, the S600+ creates a log file with the current time stamp in the working configuration folder. The log file contains all details of the transfer session until you either disable the logging option or close the Config Transfer application.

### 9.6.1 Logging a Transfer

To initiate an activity and event log for the transfer session:

1. Select the **Logging** tab on the Config Transfer screen.

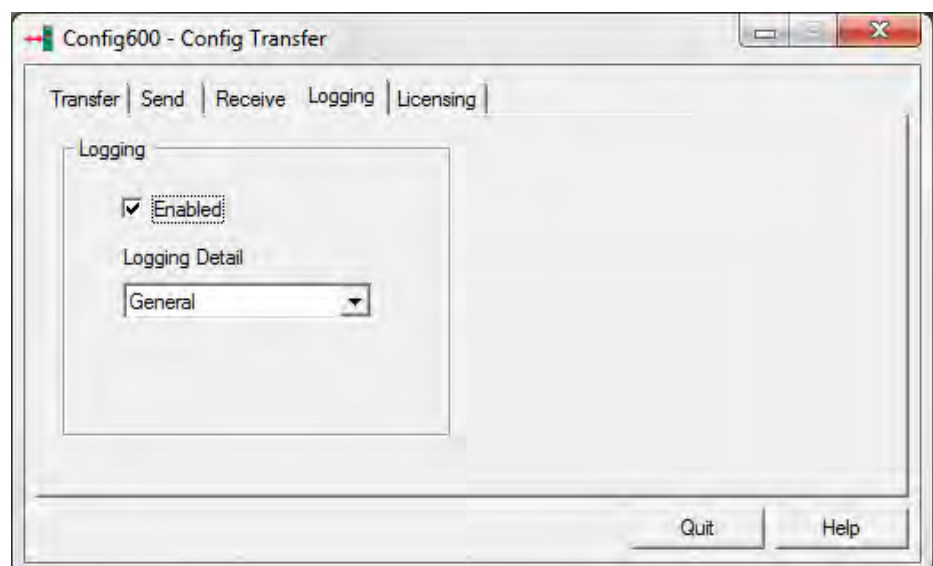

Figure 9-7. Config Transfer Logging tab

2. Select the **Enabled** check box. This activates the Logging Detail field.

3. Click ▼ to indicate the logging detail. Valid values are **General** (include only events) and **Detailed** (include both events and activity). The default is **General**.

---

**Note:** The S600+ maintains the log until you either close the application or disable the logging process.

---

## 9.7 CFX Licensing

---

**Note:** This utility **requires** you to install firmware binary 06.21 or later.

---

The Licensing utility with Config Transfer enables you to transfer a CFX software license from a USB drive (“dongle”) installed on a host PC to the S600+. The drive used to transfer Config600 licenses is a secure USB drive designed for this purpose. You **cannot** use a standard USB drive with this utility.

---

**Note:** To activate this utility, you must first cold-start the S600+ from its front display and leave the S600+ at the Cold Start menu. Also, make sure that the secure USB drive containing the license is installed on the host PC.

---

### 9.7.1 Transferring a License

To transfer a license:

1. Select the **Licensing** tab on the Config Transfer screen. The Licensing screen displays.

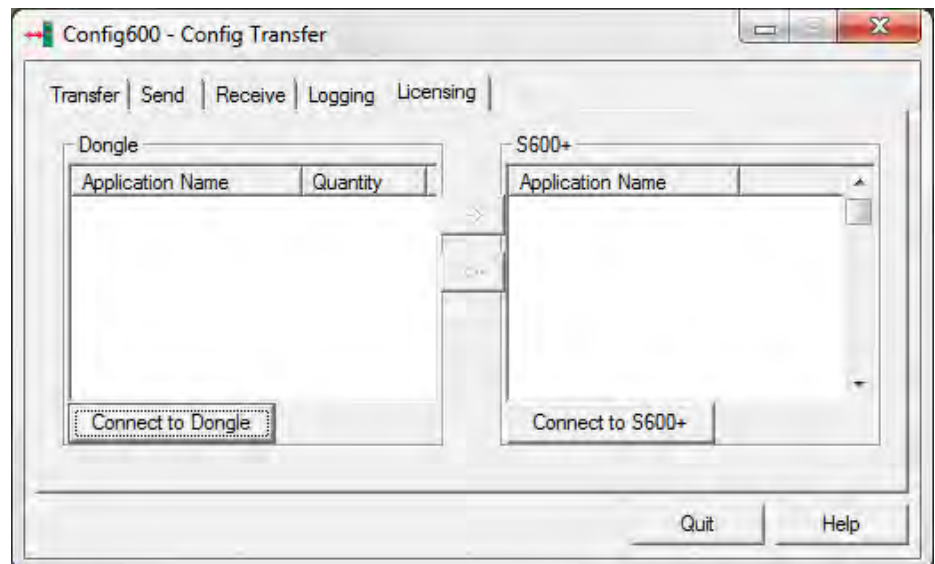

*Figure 9-8. Config Transfer Licensing tab*

2. Click **Connect to Dongle**. The utility shows all licenses on the license key in the Dongle list on the left side of the screen:



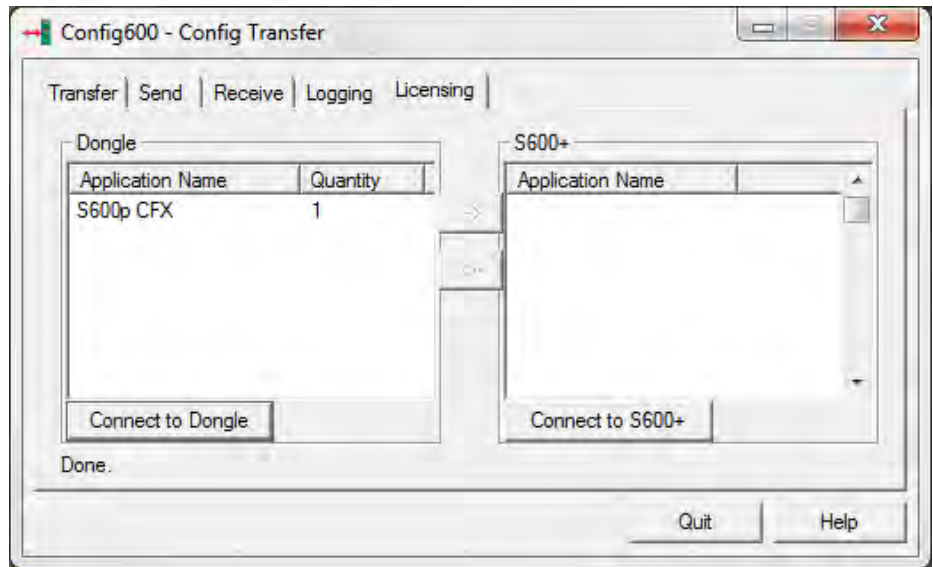
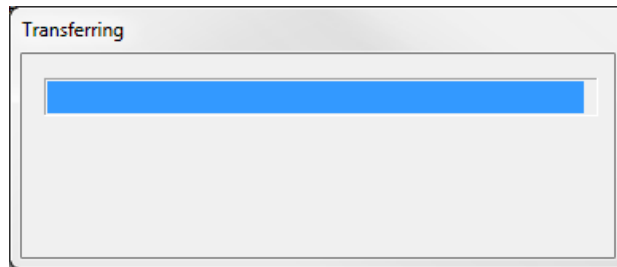

Figure 9-9. Licenses on Key

3. Click **Connect to S600+** to establish a connection to the S600+. A series of Transferring dialogs may appear while the utility makes the connection.



**Note:** When the connection completes, the utility activates the arrow keys in the center of the screen.

4. Select a license from the Dongle list and click the **right-pointing** arrow (➔) to move the license from the USB drive to the S600+. The utility displays a series of Transferring dialogs as the process occurs.

When the process completes, the utility displays a notification dialog:

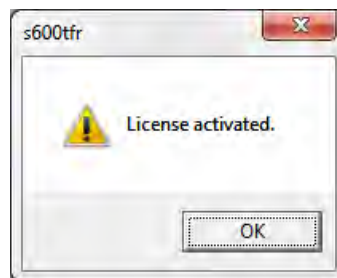

5. Click **OK** to close the dialog. The License screen now shows the license installed on the S600+. Note also that the quantity of licenses on the USB has decreased by 1.

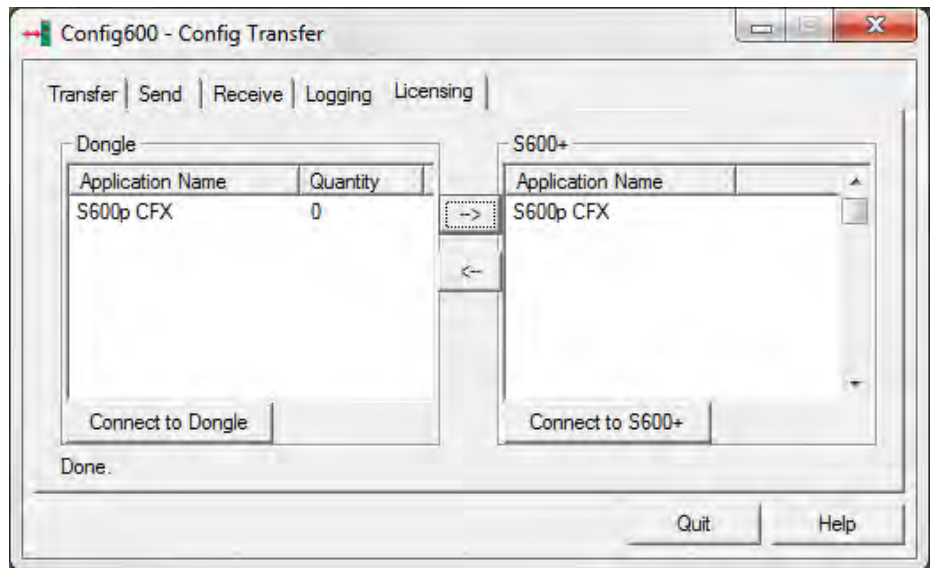

Figure 9-10. Transferred License

6. Click **Quit** to close the License utility.

### 9.7.2 Removing a License

Removing a license from the S600+ and transferring it to the secure USB drive is just as simple. After you connect to the USB drive and the S600+, select the license in the S600+ column and click the **left-pointing** (←) arrow. The system displays a notification dialog when the process completes. When you click **OK**, the utility displays the Licensing screen. Note that the quantity of licenses on the USB drive has increased by one.

## Chapter 10 – Remote Front Panel

### In This Chapter

10.1	Configuring Your PC without a Native Serial Comm Port.....	10-1
10.1.1	Changing the Port on Your USB Communications Port.....	10-2
10.2	Configuring Your PC with a Native Serial Comm Port.....	10-3
10.3	Configuring the S600+ to Use the Remote Front Panel.....	10-4
10.4	Accessing the Remote Front Panel.....	10-7
10.4.1	Remote Front Panel Startup Menu .....	10-7
10.4.2	Disabling the Remote Front Panel.....	10-8
10.4.3	Restoring the Remote Front Panel .....	10-9

Use the Remote Front Panel to configure your S600+ to perform certain functions from your PC. Connect your computer to the S600+ as directed in the *FloBoss S600+ Flow Computer Instruction Manual* (part D301150X412). The Remote Front Panel requires part number S600+EXT (the License Key for Remote Front Panel).

**Note:** For more information on the complete functionality of the Front Panel, refer to the *FloBoss S600+ Flow Computer Instruction Manual*, part D301150X412.

### 10.1 Configuring Your PC without a Native Serial Comm Port

This section details how to configure your PC to communicate between the S600+ and the Remote Front Panel application on your PC if you **do not** have a native serial communications port on your PC. If this is the case, you require a USB-to-Serial convertor cable.

1. Install the convertor software if necessary.
2. Verify the communications port number.
  - **Windows 10:** Right -click Start and select Device Manager
  - **Windows 7 or Vista:**  
Select **Start > Control Panel > Hardware and Sound > Devices and Printers > Device Manager.**
  - **Windows XP:**  
Select **Start > Control Panel > System > Hardware tab > Device Manager.**
3. Select **Ports (COM & LPT)**.
4. Verify that the **Communications Port** number is **1, 2, 3, or 4**. The Remote Front Panel **only** supports communications ports 1 through 4.

**Note:** If the communications port is not 1, 2, 3, or 4, you must change it. Refer to *Changing the Communications Port*.

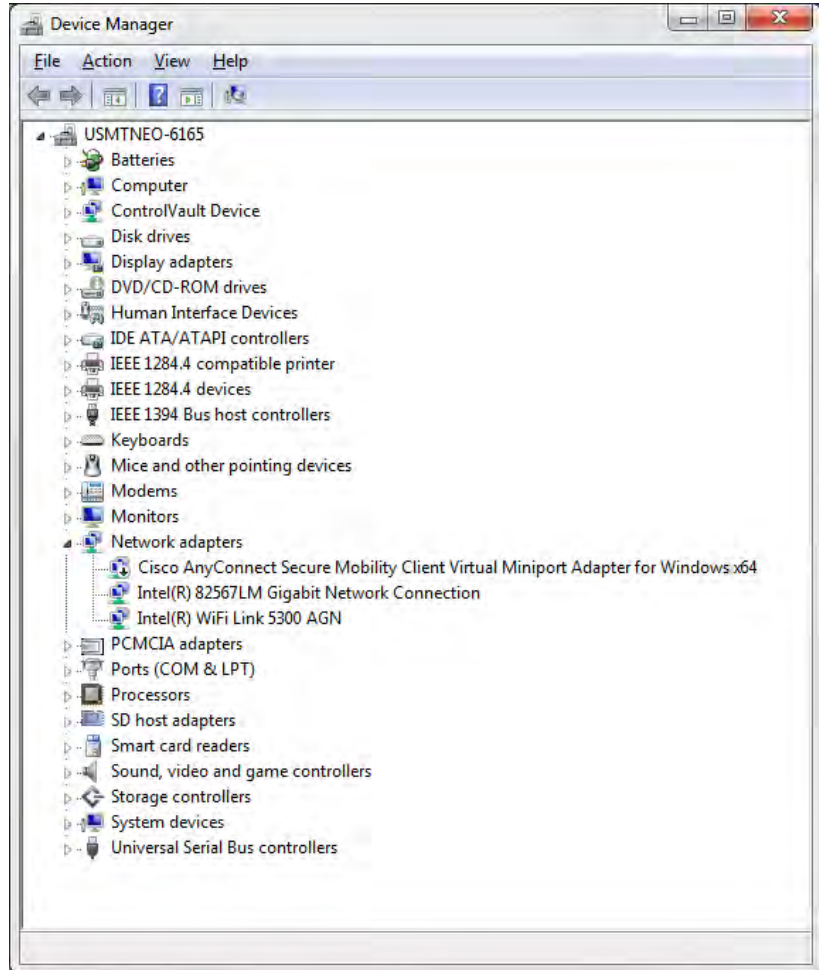

Figure 10-1. Device Manager

### 10.1.1 Changing the Port on Your USB Communications Port

The Remote Front Panel **only** supports communications ports 1 through 4. To change your communications port:

1. Right-click on the **Communications Port (COM1)** and select **Properties**.
2. Select the **Port Settings** tab.
3. Click **Advanced**.
4. Click ▼ in the **COM Port Number** field to select a communications port between 1 and 4. This is the communication port through which you communication with the S600+ and the Remote Front Panel on the PC.
5. Click **OK** in the Advanced Comm Ports Setting screen.
6. Click **OK** in the Communications Port (COM1) Properties screen.
7. Restart your computer.
8. Configure the S600+. Refer to *Configuring the S600+ to Use the Remote Front Panel*.

## 10.2 Configuring Your PC with a Native Serial Comm Port

This section details how to configure your PC to communicate between the S600+ and the Remote Front Panel application on your PC if you **have** a native serial communications port on your computer. The Remote Front Panel only supports communications ports 1 through 4. Typically a native serial port uses communication port number 1.

1. Open **Device Manager**.
  - **Windows 10:** Right -click Start and select Device Manager
  - **Windows 7 or Vista:**  
Select **Start > Settings > Control Panel > System > Advanced System Settings > Hardware tab > Device Manager**.
  - **Windows XP:**  
Select **Start > Control Panel > System > Hardware > Device Manager**.
2. Select **Ports (COM & LPT)**.



Figure 10-2. Device Manager

3. Right-mouse click on the **Communications Port** you desire to change and select **Properties**.
4. Select the **Port Settings** tab.
5. Click **Advanced**.

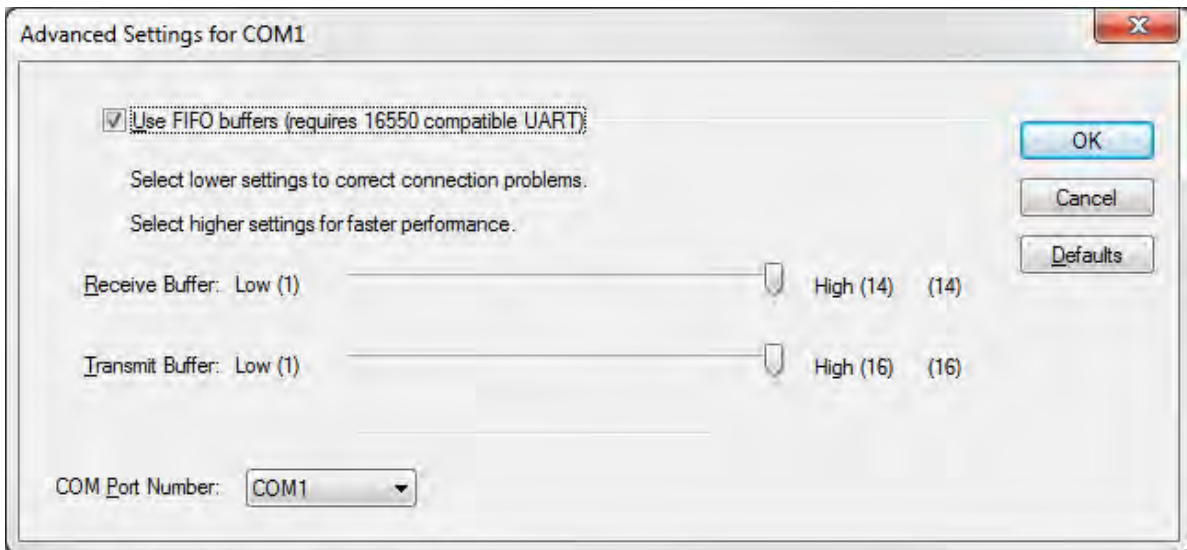

Figure 10-3. Advanced Settings

6. Click ▼ on the **COM Port Number** field to select a communication port between 1 and 4. This is the communications port through which you communicate with the S600+ and the Remote Front Panel on the PC.
7. Click **OK** in the Advanced Settings screen.
8. Click **OK** in any remaining screen.
9. Restart your computer.
10. Configure the S600+. Refer to *Configuring the S600+ to Use the Remote Front Panel*.

### 10.3 Configuring the S600+ to Use the Remote Front Panel

To use the Remote Front Panel, you must launch the Remote Front Panel application and configure your S600+.

1. Select **Start > Programs > Config600 3.3 > Remote Front Panel**.

On the S600+ front panel:

2. If the S600+ is metering, you need to access the Cold Start menu to set up the serial port parameters. To do this, select **5 (System Settings)**.

1* FLOW RATES
2* TOTALS
3* OPERATOR
4* PLANT I/O
5* SYSTEM SETTINGS
6* TECH/ENGINEER
8* CALCULATIONS

3. Select **6 (System Status)**.

```

1* UNIT SETUP
2. REPORT SETUP
3. ALARM SETUP
4. MAINTENANCE MODE
5. TOTAL RESET
6. SYSTEM STATUS
7. SOFTWARE VERSION
    
```

4. Press **CHNG**.

```

SYSTEM RUN MODE
NORMAL
P145.1 <of 1> S
    
```

5. Enter your password in the **Enter Code** field.

```

SYSTEM RUN MODE
ENTER CODE :
P145.1 <of 1> S
    
```

6. Select **1 (Cold Start)**.

```

1. COLD ST
2. WARM ST
3. GO BACK
    
```

7. Select **1 (Yes)**.

```

CONFIRM
SET TO:
COLD ST
1. YES
2. NO
    
```

8. Select **8 (Factory Setup)**.

```

1* WARM START
2* COLD START
3* NETWORK SETUP
4. REFLASH FIRMWARE
5. CONFIG SELECTION

8* FACTORY SETUP
    
```

9. Select **3 (Serial Ports)**.

```

1. CLEAR SRAM
2. FORMAT FLASH
3* SERIAL PORTS
4* DISPLAY
5* FIRMWARE
6. USB LOCK
7. DEBUG MODE
8. GO BACK
    
```

10. Select **1 (PC Setup Port)**.

```

1. PC SETUP PORT
2. GO BACK
    
```

11. Press **0** to change the Port from 2 to 0.

```
FloBoss S600+
ENTER SERIAL PORT
RANGE 2 TO 8
CURRENT 2
      0
```

12. Press **Enter**.

13. Select **2 (Go Back)**.

```
1. PC SETUP PORT
2. GO BACK
```

14. Select **8 (Go Back)**.

```
1. CLEAR SRAM
2. FORMAT FLASH
3* SERIAL PORTS
4* DISPLAY
5* FIRMWARE
6. USB LOCK
7. DEBUG MODE
8. GO BACK
```

15. Select **8 (Factory Setup)**.

```
1* WARM START
2* COLD START
3* NETWORK SETUP
4. REFLASH FIRMWARE
5. CONFIG SELECTION

8* FACTORY SETUP
```

16. Select **4 (Display)**.

```
1. CLEAR SRAM
2. FORMAT FLASH
3* SERIAL PORTS
4* DISPLAY
5* FIRMWARE
6. USB LOCK
7. DEBUG MODE
8. GO BACK
```

17. Select **1 (Display Port)**.

```
1. DISPLAY PORT
2. DISPLAY TYPE
3. GO BACK
```

18. Press **2** to change the Display from 2 to 1.

```
FloBoss S600+
ENTER SERIAL PORT
RANGE 1 TO 8
CURRENT 1
      2
```

19. Press **Enter**.



## 20. Power cycle the S600+.

After launching the Remote Front Panel and configuring the S600+, the S600+ displays "REMOTE FRONT PANEL IN USE" on the Front Panel. This places the S600+'s front panel under the control of the Remote Front Panel utility.

## 10.4 Accessing the Remote Front Panel

To start the Remote Front Panel, click **Start > Programs > Config600 3.3 > Remote Front Panel**. The Remote Front Panel displays.



Figure 10-4. Remote Front Panel

The Remote Front Panel utility functions exactly like the actual S600+ front panel. Refer to the *FloBoss S600+ Flow Manager Instruction Manual* (part D301150X412).

### 10.4.1 Remote Front Panel Startup Menu

After you launch the Remote Front Panel and configure the S600+, the S600+ displays "REMOTE FRONT PANEL IN USE" on the Front Panel. This places the S600+ front panel under the control of the Remote Front Panel utility.

The Remote Front Panel displays the Startup Menu:

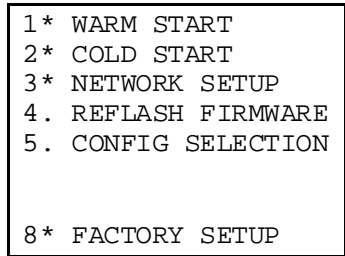

Figure 10-5. Remote Front Panel Startup Menu

**Note:** An asterisk (\*) after an option number indicates a sub-menu. A period indicates a subsequent data screen.

Field	Description
1* Warm Start	Restarts a S600+ from the point prior to where the S600+ lost power.
2* Cold Start	Builds a new metering database on the S600+ from the files in Flash memory.
3* Network Setup	Configures the TCP/IP, Gateway, and Modbus addresses.
4. Reflash Firmware	Reprograms the S600+ operating system firmware from Flash memory.
5. Config Selection	Displays the configuration files currently downloaded to the S600+.
8* Factory Setup	Clears the SRAM and formats Flash memory and changes additional settings. <b>Note:</b> Use this option <b>only</b> at the direction of a factory representative.

### 10.4.2 Disabling the Remote Front Panel

To disable the Remote Front Panel, you must perform the following in the Remote Front Panel application:

From the Remote Front Panel:

1. Return to the main Remote Front Panel menu.

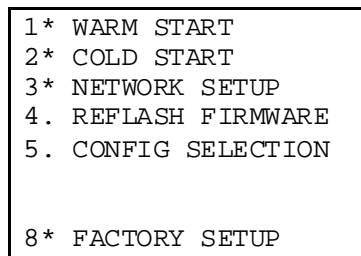

2. Select **8 (Factory Setup)**.

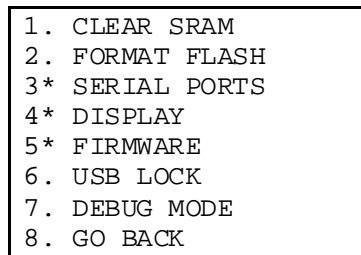

**3. Select 4 (Display).**

```
1. DISPLAY PORT
2. DISPLAY TYPE
3. GO BACK
```

**4. Select 1 (Display Port).**

```
Floboss S600+
ENTER SERIAL PORT
RANGE 1 to 8
CURRENT 2
1
```

**5. Press 1 to change the display port from 2 to 1.****6. Press Enter.****7. Press 3 (Go Back).**

```
1. DISPLAY PORT
2. DISPLAY TYPE
3. GO BACK
```

**8. Press 3 (Go Back).****9. Select Factory Setup.****10. Select Serial Ports.**

```
1. PC SETUP PORT
2. GO BACK
```

**11. Select 1 (PC Setup Port).**

```
FloBoss S600+
ENTER SERIAL PORT
RANGE 2 to 8
CURRENT 0
2
```

**12. Press 2 to change the port from 0 to 2.****13. Press Enter.**

---

**Note:** Disregard any undesirable characters that may occur in the display.

---

**14. Power cycle the S600+.**

### 10.4.3 Restoring the Remote Front Panel

In the event of a remote front panel communications failure, you may need to restore the serial communications to the normal front panel. This is possible by pressing the S600+ Front Panel keys in the following order when powering up the S600+:

To restore the Remote Front Panel if remote communications fail:

1. Remove power and then re-apply power to the S600+.
2. When the “REMOTE FRONT PANEL ENABLED” message displays, press **123 456 789 -0.** from left to right (the last three keys in the sequence are the dash, the zero, **and** the period).

---

**Note:** You must complete the key sequence within 5 seconds after the message displays. If you are unsuccessful the first time, repeat the process.

---

3. The Cold Start menu displays when the process is successful.

# Chapter 11 – Remote Archive Uploader

## In This Chapter

11.1	Accessing the Remote Archive Uploader.....	11-2
11.2	Automatic Archive Polling.....	11-2
11.2.1	Configure Automatic Polling.....	11-2
11.2.2	Add or Edit an Automatic Poll.....	11-4
11.2.3	Enable Automatic Polling.....	11-6
11.3	Manual Archive Polling.....	11-6
11.3.1	Configuring Config600 Communications.....	11-7
11.3.2	Reload Tree.....	11-8
11.3.3	Upload All Reports / Upload New Reports.....	11-10
11.4	Viewing Reports.....	11-11
11.4.1	Report Archive.....	11-11
11.5	Saving.....	11-12
11.5.1	Directory Settings (File Locations).....	11-12
11.5.2	File Settings.....	11-13
11.5.3	Save As.....	11-15
11.5.4	Folder Formats.....	11-15
11.5.5	Data Integrity.....	11-17
11.6	Printing the Report.....	11-18
11.6.1	Print.....	11-18
11.6.2	Print Preview.....	11-18
11.6.3	Print Setup.....	11-19
11.7	Abort Transfer.....	11-20



The Remote Archive Uploader allows you to automatically upload all reports and alarms in the historical archive in the S600+ flow computer, and manually upload the following:

- Constant Log
- Display Dump
- List of all available alarms
- List of current alarms
- Current report
- Alarm / Event History File

---

**Note:** Support for the Alarm / Event History feature was withdrawn for firmware version 5.0 and later.

---

- All reports in the Historical Archive

---

**Note:** The Remote Archive Uploader requires part number S600+EXT (the license key for Archive Uploader).

---

The Remote Archive Uploader logs all significant events to a log file, which is also held in the archive folder. Logged events include:

- Manual Upload of Constant Log
- Manual Upload of Display Dump
- Manual Upload of All Alarms
- Manual Upload of Current Alarms
- Manual Upload of Current Report
- Manual Upload of Alarm/Event History
- Failed to Open Communications Port
- Link Failed

- Manual Load of Report Files
- Automatic Load of Report Files

All events are date- and time-stamped.

## 11.1 Accessing the Remote Archive Uploader

---

To launch the Remote Archive Uploader, from your PC select **Start > All Programs > Config600 3.3 > Remote Archive Uploader**. The Remote Archive Uploader screen displays.

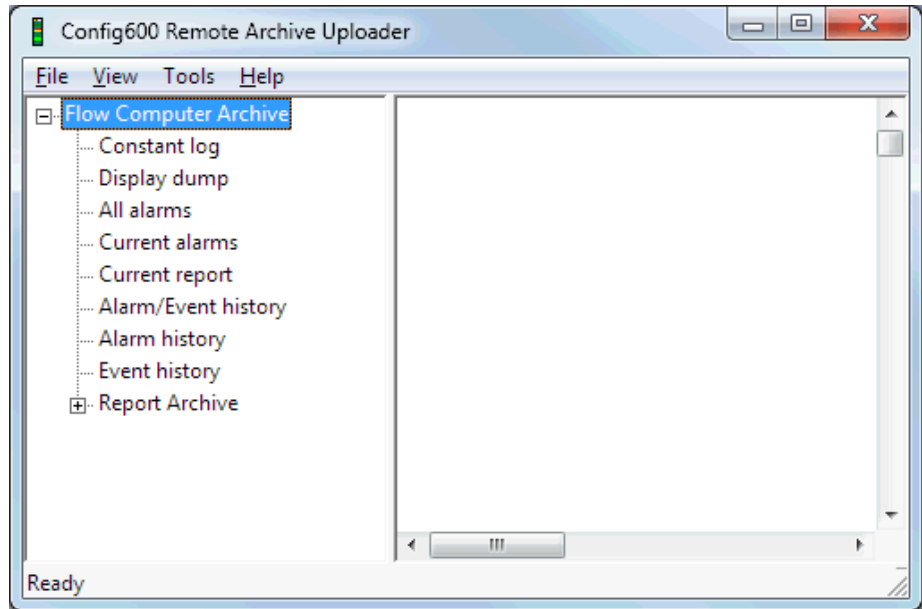

Figure 11-1. Remote Archive Uploader screen

## 11.2 Automatic Archive Polling

---

The Remote Archive Uploader allows you to automatically poll all reports and alarms in the historical archive of the S600+ flow computer. You configure the archive type, frequency, and the communications link the Config600 software uses on the Flow Computer Poll Sequence screen.

### 11.2.1 Configure Automatic Polling

You must configure the archive type, frequency, and the communications link the Config600 software uses to poll for data.

1. Select **Tools > Flow Computer List**. The Flow Computer Poll Sequence screen displays showing any previously configured reports.

**Notes:**

- Each column on the Flow Computer Poll Sequence screen represents a single configured archive poll.
- The Flow Computer poll sequence list is reset whenever you change the directory settings (Tools > Directory settings). For more information, refer to *Section 11.5, Saving*.

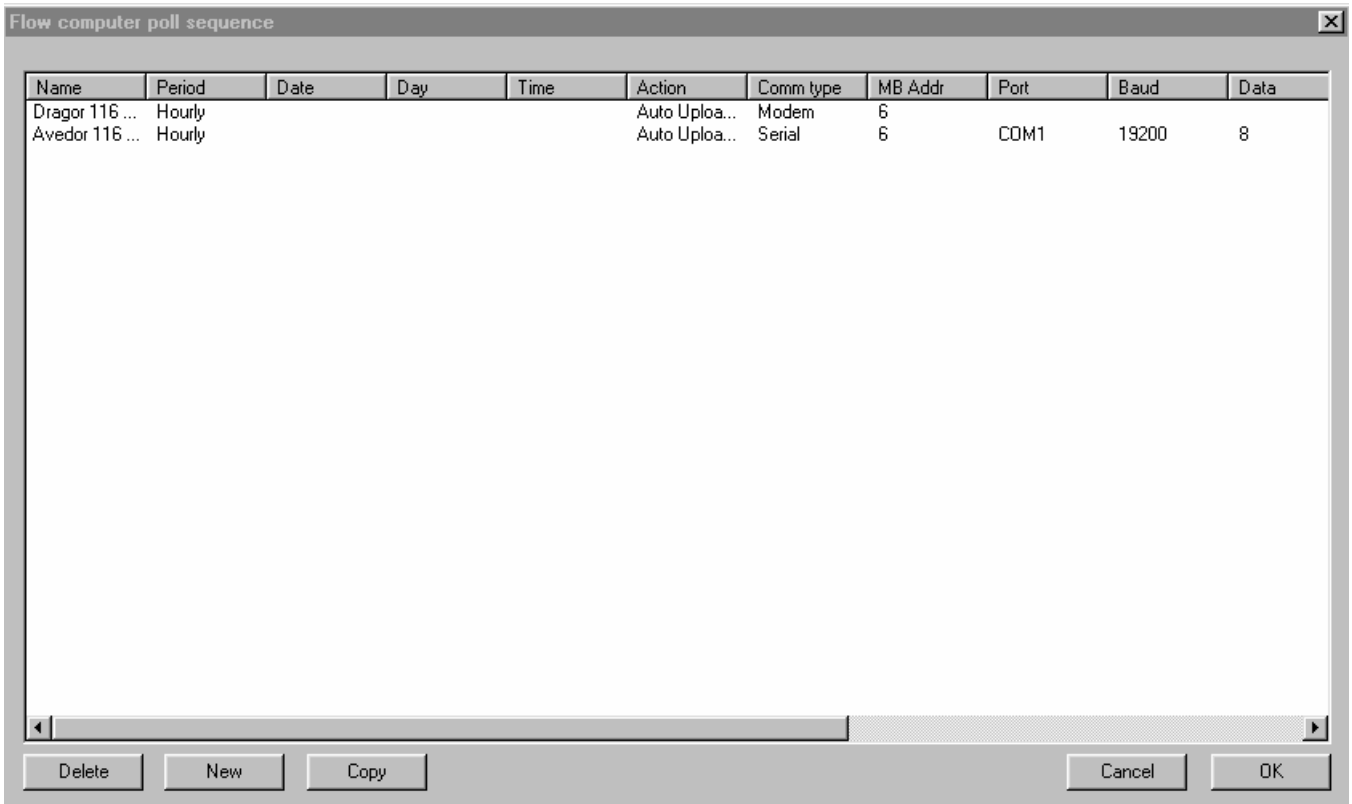

Figure 11-2. Display Editor with shortcut menu

2. Review the values displayed for each configured archive poll:

Option	Description
<b>Name</b>	Shows a description of the archive poll. This is used by Config600 to create file or folder names when storing archives on your PC. <b>Note:</b> You enter this description in the Comment field on the Edit FC List screen.
<b>Period</b>	Shows the frequency that Config600 polls the flow computer for the archive. Valid values are Hourly, Daily, Weekly, or Monthly.
<b>Date</b>	Shows the date of the month Config600 polls the flow computer for the archive. Valid values are 1–31. <b>Note:</b> Data is displayed only for Monthly archive uploads.
<b>Day</b>	Shows the day of the week Config600 polls the flow computer for the archive. <b>Note:</b> Data is displayed only for Weekly archive uploads.

<b>Option</b>	<b>Description</b>
<b>Time</b>	Shows the time of day to Config600 polls the flow computer for the archive. <b>Note:</b> Data displays only for Daily, Weekly, or Monthly archive uploads.
<b>Action</b>	Shows the archive poll type of the selected poll. Valid values are Auto Upload All (uploads ALL of the archived reports from the S600+) or Auto Upload New (uploads only <b>new</b> archived reports from the S600+).
<b>Comm Type</b>	Shows the communication type the Config600 software uses to poll the flow computer for the archive data. Valid values are <b>Serial</b> , <b>Ethernet</b> , or <b>Modem</b> .
<b>MB Address</b>	Shows the Modbus address of the remote flow computer.
<b>Port</b>	Shows the PC port Config600 uses when polling the S600+ for archive data.
<b>Baud</b>	Shows the baud rate Config600 uses when polling the S600+ for archive data.
<b>Data</b>	Shows the number of data bits in use for serial communications Config600 uses when polling the S600+ for archive data.
<b>Stop</b>	Shows the number of stop bits in use for serial communications used by Config600 when polling the S600+ for the archive data.
<b>Parity</b>	Shows the parity in use for serial communications Config600 uses when polling the S600+ for archive data.
<b>TCP/IP Addr</b>	Shows the TCP/IP address of the flow computer.
<b>TCP/IP Port</b>	Enter the dedicated TCP port at the S600+ with which you desire to communicate. Valid ports are 6001, 6002. Ensure no other device is communicating with the S600+ on this port. <b>Note:</b> Port 6002 is recommended over 6001.
<b>MODEM Port</b>	PC port in use for MODEM communications.
<b>Phone</b>	Phone number in use for MODEM communications.
<b>Delete</b>	Select a flow computer and click <b>Delete</b> to remove it from the Flow computer poll sequence screen.
<b>New</b>	Click <b>New</b> to add a new flow computer to poll.
<b>Copy</b>	Select a flow computer and click <b>Copy</b> to duplicate an existing configuration.

### 11.2.2 Add or Edit an Automatic Poll

To add a new or edit an existing flow computer:

1. Click **New** or double-click the name of an existing archive poll configuration to edit. The Edit FC List Item screen displays.



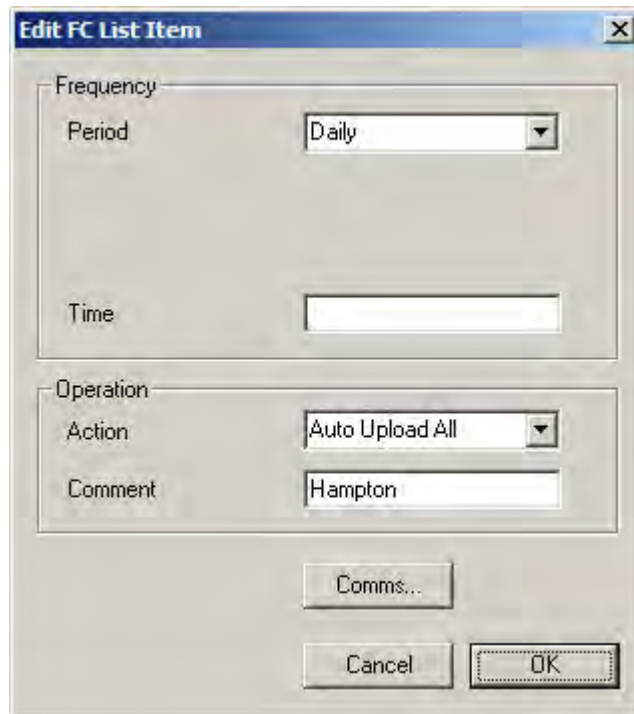

Figure 11-3. Edit FC List Item screen

- Complete (or update) the values for the selected flow computer:

Option	Description
<b>Period</b>	Selects the frequency that Config600 software polls the S600+ for the archive. Click ▼ to display all valid options. Valid options are <b>Hourly</b> , <b>Daily</b> , <b>Weekly</b> , or <b>Monthly</b> .
<b>Date</b>	Sets the date of the month to perform the poll. <b>Note:</b> This field is active <b>only</b> if you select <b>Monthly</b> in the Period field.
<b>Day</b>	Sets the day of the week to perform the poll. <b>Note:</b> This field is active <b>only</b> if you select <b>Weekly</b> in the Period field.
<b>Time</b>	Sets the time of day to perform the poll. <b>Note:</b> This field is active <b>only</b> if you select <b>Daily</b> , <b>Weekly</b> , or <b>Monthly</b> in the Period field.
<b>Action</b>	Selects the archive data to upload. Click ▼ to display all valid options. Valid options include Auto Upload All or Auto Upload New. <b>Auto Upload All</b> Uploads all of the archived reports from the S600+ and saves them into the folder on the PC using the <b>Tools &gt; Manual Comms Settings</b> . <b>Auto Upload New</b> Uploads only new archived reports from the S600+ and saves them into the folder on the PC using the <b>Tools &gt; Manual Comms Settings</b> .
<b>Comment</b>	Indicates a name to identify the archive poll. Config600 software uses this name to create file or folder names for the reports uploaded from the selected flow computer.

Option	Description
Comms...	Click <b>Comms...</b> to configure communication settings the Config600 software uses to retrieve data from the selected flow computer. Refer to <i>Section 11.3.1, Configuring Config600 Communications.</i>

### 11.2.3 Enable Automatic Polling

If you enable automatic polling, Config600 performs any archive polls you configure in the Flow Computer Poll Sequence screen (*Section 11.3*). To enable the automatic polling:

Select **Tools > Enable Automatic Operation**. Config600 automatically retrieves any reports that you defined on the Flow Computer Poll Sequence screen.

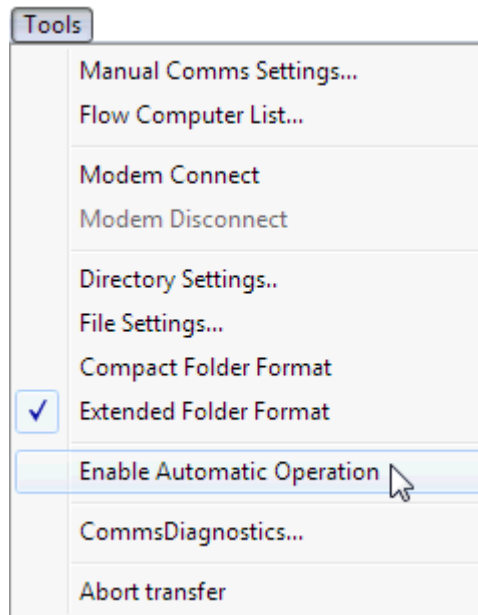

*Figure 11-4. Tools Menu - Automatic Operation Enabled*

Config600 software automatically polls the S600+ at the specified times and saves the uploaded archives in the Archive folder.

---

**Note:** The format is exactly the same as for the Manual upload command except that the folder names are based on the row in the flow computer list.

---

### 11.3 Manual Archive Polling

---

You can manually upload reports on an as-needed basis. You can manually upload the following data types:

- Constant Log
- Display Dump
- List of all available alarms
- List of current alarms
- Current report
- Alarm / Event History File

**Note:** Support for the Alarm / Event History feature was withdrawn for firmware version 5.0 and above.

- All reports in the Historical Archive

To perform a manual archive poll, you must configure the communication settings Config600 uses to perform the manual poll. Config600 then waits for you to issue the **Reload Tree**, **Upload All**, or **Upload New** command from the File menu to poll the S600+.

### 11.3.1 Configuring Config600 Communications

You must configure the communication settings Config600 uses to retrieve data from selected flow computers. An editor is available from the Tools menu, which allows you to set up the port, TCP/IP address, or telephone details to use in connecting to the flow computer.

1. Select **Tools > Manual Comm Settings** to display the Comms Properties screen.

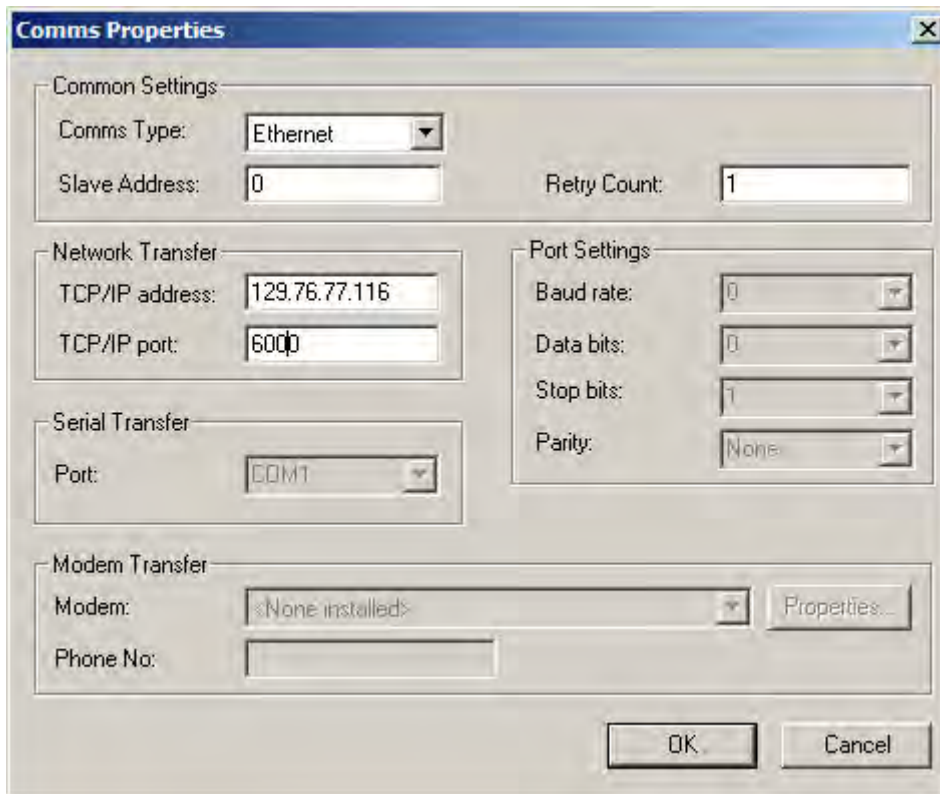

Figure 11-5. Typical Display Page (Stream 2 Flow Limits shown)

2. Complete the values for the communications port Config600 uses:

Field	Description
<b>Comm Type</b>	Selects the communication type Config600 uses to perform a manual poll. Click ▼ to display all valid types. Valid values are <b>Serial (the default)</b> , <b>Ethernet</b> , or <b>Modem</b> .
<b>Slave Address</b>	Sets a valid Modbus slave address for the flow computer.

<b>Field</b>	<b>Description</b>
<b>Retry Count</b>	Sets the number of times the Remote Archive Uploader should attempt to communicate with the S600+ before it times out.
<b>TCP/IP Address</b>	Sets IP address for the S600+ with which you desire to communicate. <b>Note:</b> This field is active <b>only</b> if you select <b>Ethernet</b> in the Comms Type field.
<b>TCP/IP Port</b>	Sets the dedicated TCP port at the S600+ with which you desire to communicate. Valid ports are 6001 and 6002; port 6002 is recommended. Ensure no other device is communicating with the S600+ on this port. <b>Note:</b> This field is active <b>only</b> if you select <b>Ethernet</b> in the Comms Type field.
<b>Baud Rate</b>	Sets the serial transfer rate. Click ▼ to display all valid values. The default value is <b>38400</b> . <b>Note:</b> This field is active <b>only</b> if you select <b>Serial</b> or <b>Modem</b> in the Comms Type field.
<b>Data Bits</b>	Sets the number of data bits the port uses. Click ▼ to display all valid values. The default value is <b>8</b> . <b>Note:</b> This field is active <b>only</b> if you select <b>Serial</b> or <b>Modem</b> in the Comms Type field.
<b>Stop Bits</b>	Sets the period length. Click ▼ to display all valid values. The default value is <b>1</b> . <b>Note:</b> This field is active <b>only</b> if you select <b>Serial</b> or <b>Modem</b> in the Comms Type field.
<b>Parity</b>	Sets the type of parity used to detect data corruption during transmission. Click ▼ to display all valid values. The default value is <b>None</b> . <b>Note:</b> This field is active <b>only</b> if you select <b>Serial</b> or <b>Modem</b> in the Comms Type field.
<b>Port</b>	Sets the communication port to using during serial transmissions. Click ▼ to display all valid values. The default value is <b>COM1</b> . <b>Note:</b> This field is active <b>only</b> if you select <b>Serial</b> in the Comms Type field.
<b>Modem</b>	Sets the type of modem you will use in communications. Click ▼ to display all valid values. <b>Note:</b> This field is active <b>only</b> if you select <b>Modem</b> in the Comms Type field.
<b>Phone No.</b>	Sets the phone number of the modem you will use in communications. <b>Note:</b> This field is active <b>only</b> if you select <b>Modem</b> in the Comms Type field.
<b>Properties</b>	Click the Properties button to configure additional parameters for the modem. <b>Note:</b> This button is active <b>only</b> if you select <b>Modem</b> in the Comms Type field.

3. Click **OK** to save any changes. The Remote Archive Uploader screen redisplay.

### 11.3.2 Reload Tree

This command enables you to manually generate, view, print, and save the following:

- Constant Log
- Display dump
- List of all available alarms
- List of current alarms
- Current report
- Alarm / Event History File

**Note:** Support for the Alarm / Event History file feature was withdrawn for firmware 05.xx and above. Please contact technical support for assistance.

Select the **File > Reload Tree**. Config600 software reads the report index file from the S600+ (using the parameters you configure on the Manual Communication Settings screen) and displays the contents.

**Note:** If you set the manual communication type to **Modem**, you must manually connect the modem before you can select the Reload Tree command.

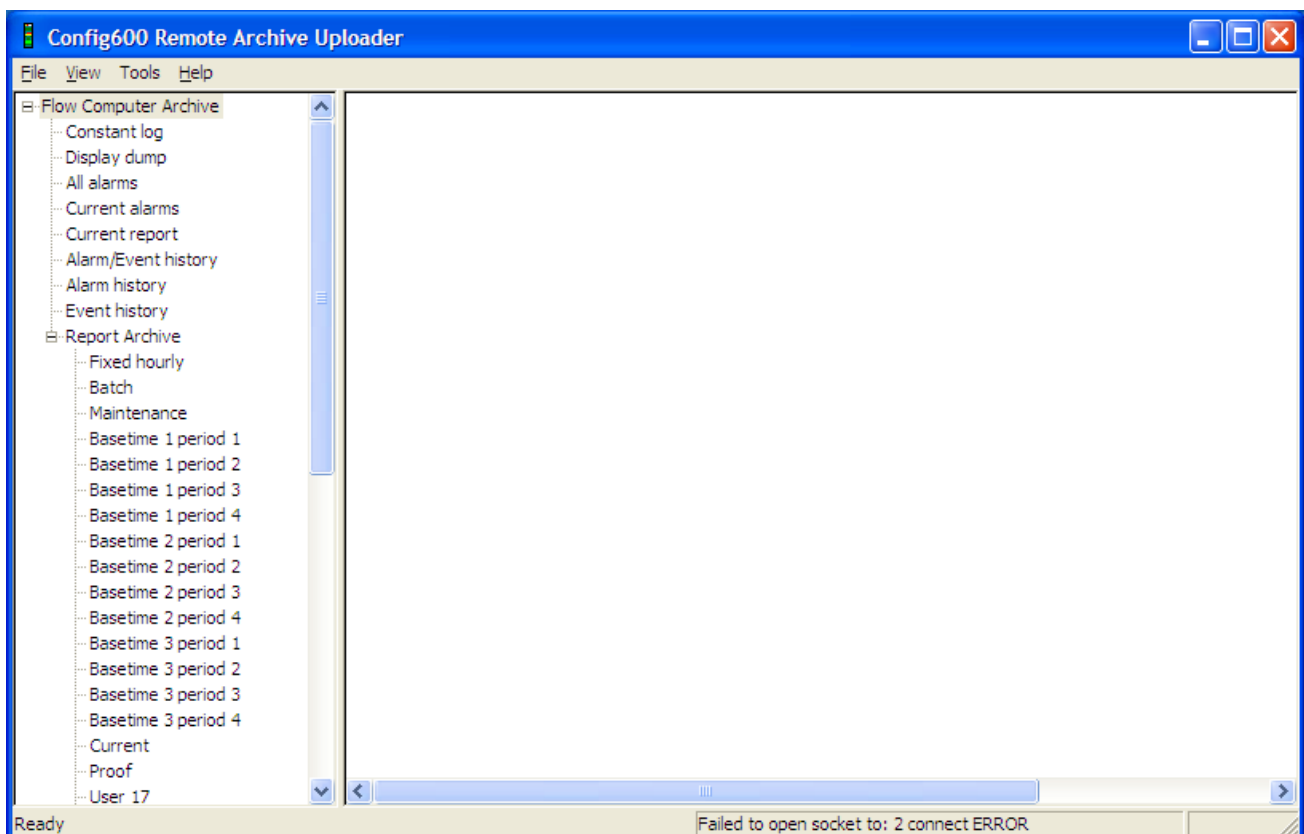

Figure 11-6. Remote Archive Uploader Tree

The tree shows a list of the files available in the S600+ archive. To upload a file, click the file in the tree. The package extracts that file from the S600+ and displays it on the right side of the screen.

**Notes:**

- The system **does not** automatically store data generated using this method on the PC. You must manually save these reports using the **File > Save As** command.
- The Current Report generated using this method is **not** archived in the S600+, as its generation bypasses the S600+ print and archiving mechanism. If a generated Current Report is required, it should be generated manually. If a Current Report has been generated at the S600+, it appears along with all other archived reports in the tree on the left side of the screen.

**Progress Bar** A progress bar display at the bottom of the window and provides details of the action underway and its percentage completion. A small modem graphic has also been added to display the modem connection status.

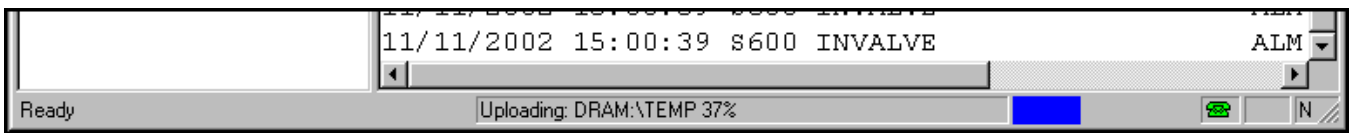

*Figure 11-7. Progress Bar*

### 11.3.3 Upload All Reports / Upload New Reports

The Upload All Reports and Upload New Reports commands enable manual polling of the S600+ using the communication parameters you entered on the **Tools > Manual Comms Settings** page. The system automatically saves files generated by this method in the user-defined file directory on your PC.

To perform an manual poll using the Upload All Reports or Upload New Reports command:

1. Select **File > Upload All Reports** (to upload **all** archived reports from the S600+ and save them into the folder on the PC) ) **or** select **File > Upload New Reports** (to upload only **new** archived reports from the S600+ and save them into the folder on the PC). The Flow Computer Selection screen displays.

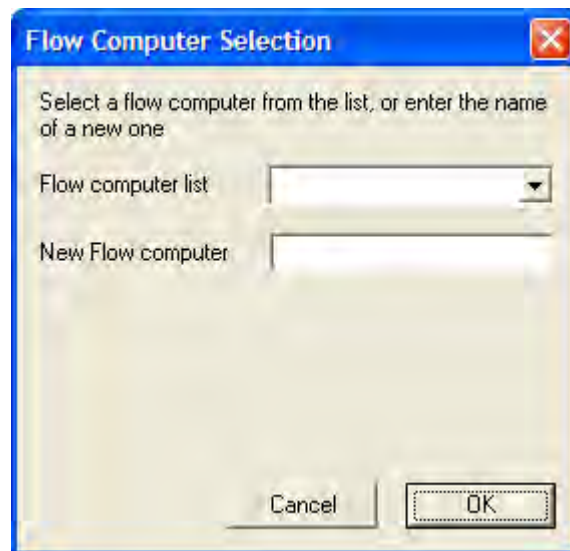

Figure 11-8. Manual Upload Options

- Complete the values for the desired flow computer:

Field	Description
<b>Flow computer list</b>	<p>Click ▼ to display all valid flow computers you defined on the Flow Computer List screen.</p> <p><b>Notes:</b></p> <ul style="list-style-type: none"> <li>These options then become either the folder name (extended folder structure) or part of the file name (compact folder structure).</li> <li>The flow computer list option uses the communications details you enter into the list (Tools &gt; Flow Computer List).</li> </ul>
<b>New Flow computer</b>	<p>Sets the name of the new flow computer with which you desire to communicate.</p> <p><b>Notes:</b></p> <ul style="list-style-type: none"> <li>These options then become either the folder name (extended folder structure) or part of the file name (compact folder structure).</li> <li>New Flow Computer option uses the default communications settings as per the Reload Tree command although the modem now connects and disconnects automatically.</li> </ul>

- Click **OK** to perform the manual poll.

## 11.4 Viewing Reports

You can view reports stored on the S600+.

**Note:** The system retrieves reports from the S600+ using the communication settings you configured on the Manual Comms Settings screen.

### 11.4.1 Report Archive

You can view reports stored in the S600+ archives. To view reports:

1. Select **File > Reload Tree** to display all reports loaded in the S600+ archive.
2. Double-click **Report Archive**.
3. Double-click the report you desire to view.

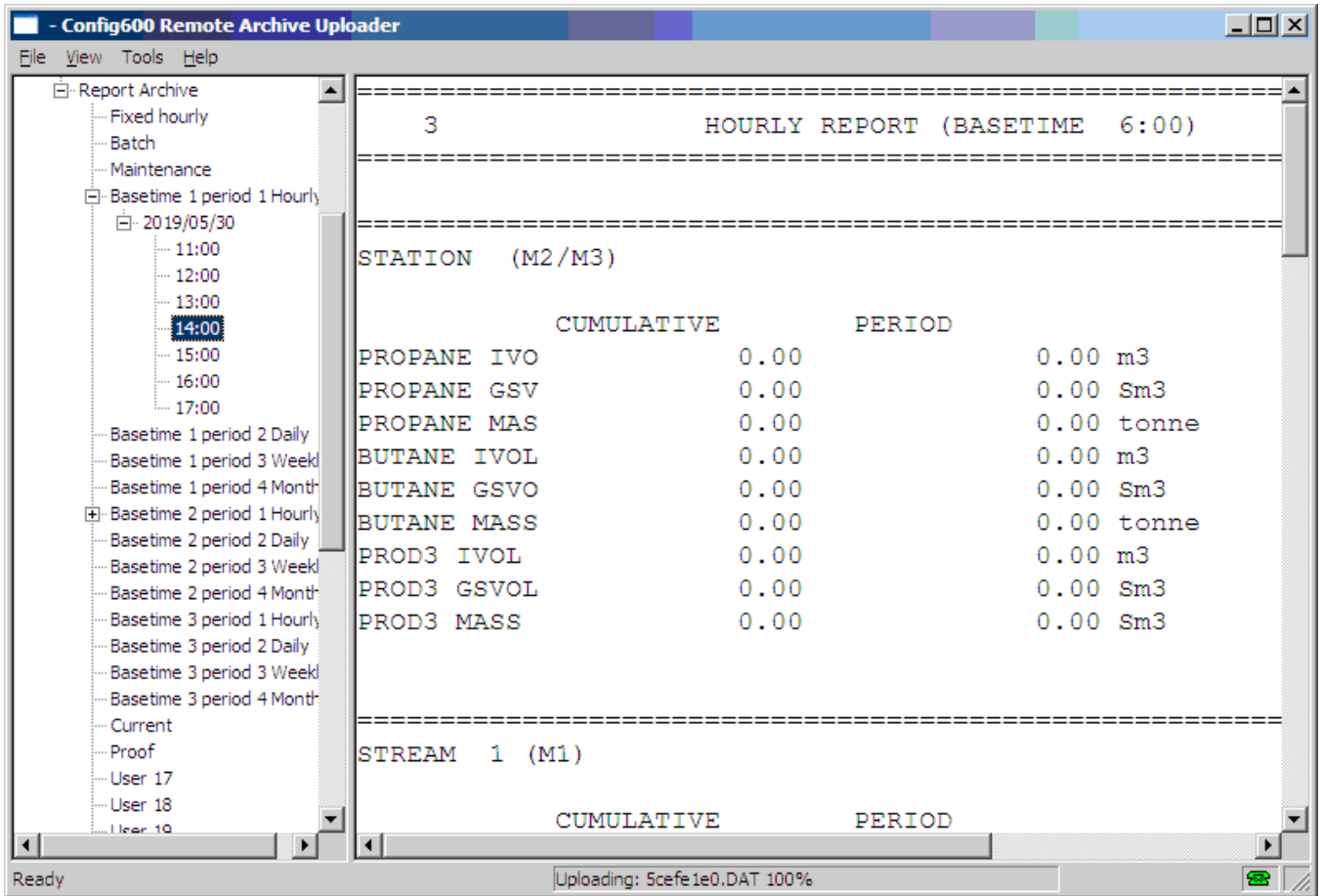

Figure 11-9. Report Archive

## 11.5 Saving

By default, the system saves automatically retrieved archives on your PC's Config600 Archive folder. You can change the default location using the Directory Settings command or manually save a report using the Save As command.

### 11.5.1 Directory Settings (File Locations)

Archives retrieved automatically are saved on your PC in the Config600 Archive folder. You can configure Config600 to save archive uploads to a different folder using the Directory Settings command. To configure a different folder:

1. Select **Tools > Directory Settings**. The Select Folder screen displays.



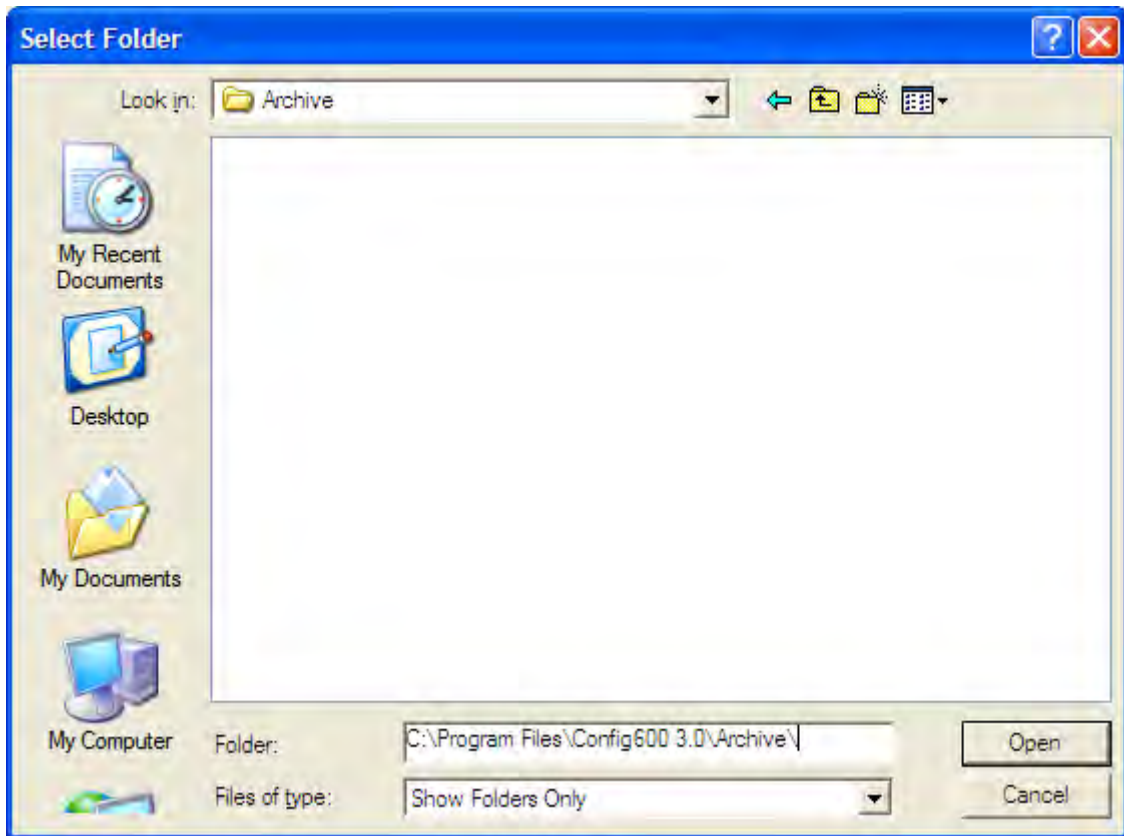

Figure 11-10. Select Folder

2. Navigate to the folder on your PC where you want Config600 to save your uploaded archives.
3. Click **Open** to select the new location.

## 11.5.2 File Settings

You can configure the file format when saving archive uploads. You can choose from two formats: .txt file format or .PDF file format. To configure the file format:

1. Select **Tools > File Settings**. The Save File Settings screen displays.

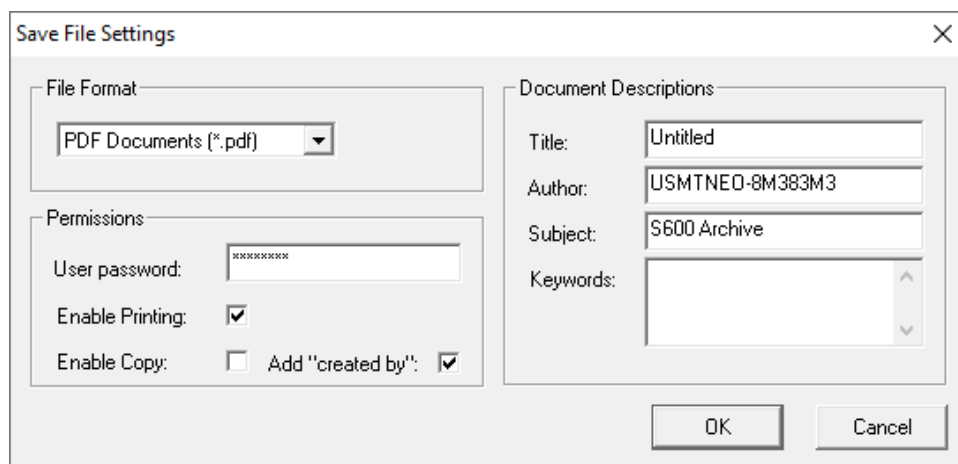

Figure 11-11. Select Folder

2. Click ▼ to display all valid file format options. If you select Text File (\*.txt) format type, the archive uploads are saved as .txt files. If you select PDF Documents (\*.pdf) format type, the archive uploads are saved as .pdf files.

Field	Description
<b>File Format</b>	Click ▼ to choose a file format for report uploads. Valid options are <b>Text File (*.txt)</b> (the system saves archive uploads as .txt files) or <b>PDF Documents (*.pdf)</b> (the system saves archive uploads as .pdf files). The default is <b>PDF Documents (*.pdf)</b> .
<b>User Password</b>	Indicates the password for the user of the document. The user_password is allowed to be set to NULL or zero length string. The max length of user pass is 32 characters. If the password is set, the min length is 8 characters. <b>Note:</b> The option is valid <b>only</b> if you select <b>PDF Documents (*.pdf)</b> as the file format type.
<b>Enable Printing</b>	Enables, if selected, the Print option in the PDF file. <b>Note:</b> The option is valid <b>only</b> if you select <b>PDF Documents (*.pdf)</b> as the file format type.
<b>Enable Copy</b>	Enables, if selected, the Copy option in the PDF file. <b>Note:</b> The option is valid <b>only</b> if you select <b>PDF Documents (*.pdf)</b> as the file format type.
<b>Add “created by”</b>	Includes, if selected, the Windows login name of the person who created the document and the date/time the document was created at the bottom of every page. This information is provided in the following format: <i>Document created by operator: &lt;xxxxxxx&gt; at &lt;Date / Time&gt;</i> Where xxxxxx is the windows login name <b>Note:</b> The option is valid <b>only</b> if you select <b>PDF Documents (*.pdf)</b> as the file format type.
<b>Title</b>	Sets a name to be saved in the Document Properties of the PDF file. <b>Note:</b> The option is valid <b>only</b> if you select <b>PDF Documents (*.pdf)</b> as the file format type.
<b>Author</b>	Sets an author name to be saved in the Document Properties of the PDF file. The default is the user computer name. <b>Note:</b> The option is valid <b>only</b> if you select <b>PDF Documents (*.pdf)</b> as the file format type.
<b>Subject</b>	Sets a subject to be saved in the Document Properties of the PDF file. The default value is <b>S600 Archive</b> . <b>Note:</b> The option is valid <b>only</b> if you select <b>PDF Documents (*.pdf)</b> as the file format type.
<b>Keywords</b>	Provides the keywords to be saved in the Document Properties of the PDF file. <b>Note:</b> The option is valid <b>only</b> if you select <b>PDF Documents (*.pdf)</b> as the file format type.

3. Click **OK** to save your changes.

### 11.5.3 Save As

To manually save a report:

1. When viewing a report, select **File > Save As**. The Save As screen displays.

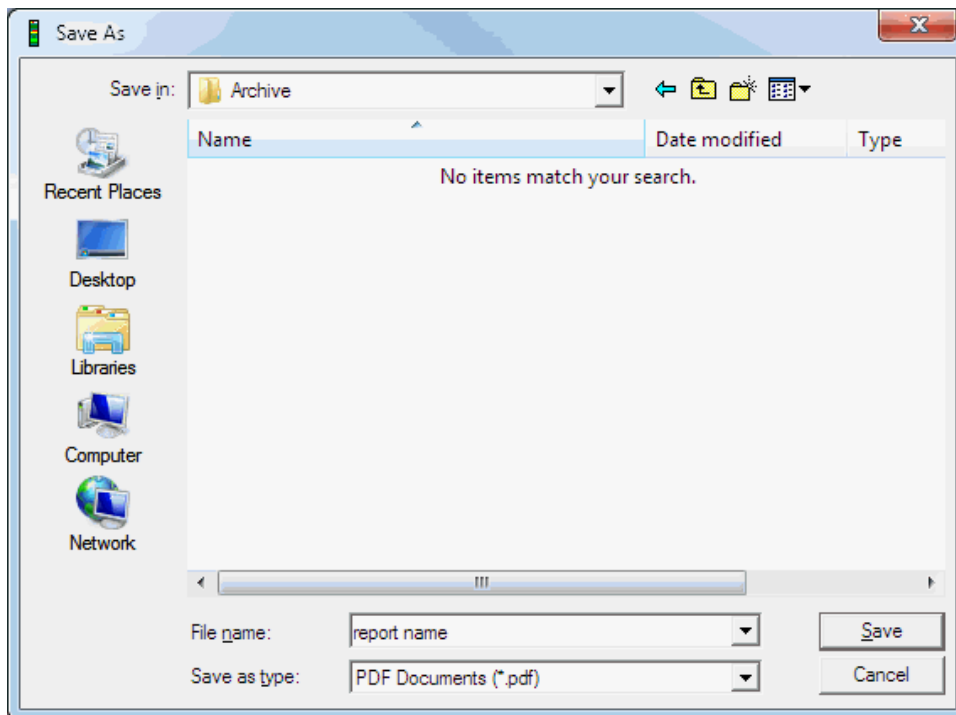

*Figure 11-12. Save As*

2. Type a file name in the File Name field.
3. Navigate to the location where you desire to store the report.
4. Click **Save** to save the report.

### 11.5.4 Folder Formats

You can configure what folders on your PC are created when saving archive uploads. You can choose from two folder formats: compact folder format or extended folder format.

**Compact Folder Formats** Select **Tools > Compact Folder Format** to enable files uploaded through either manual or automatic operation, to be automatically stored in the same folder (called FCD Data).

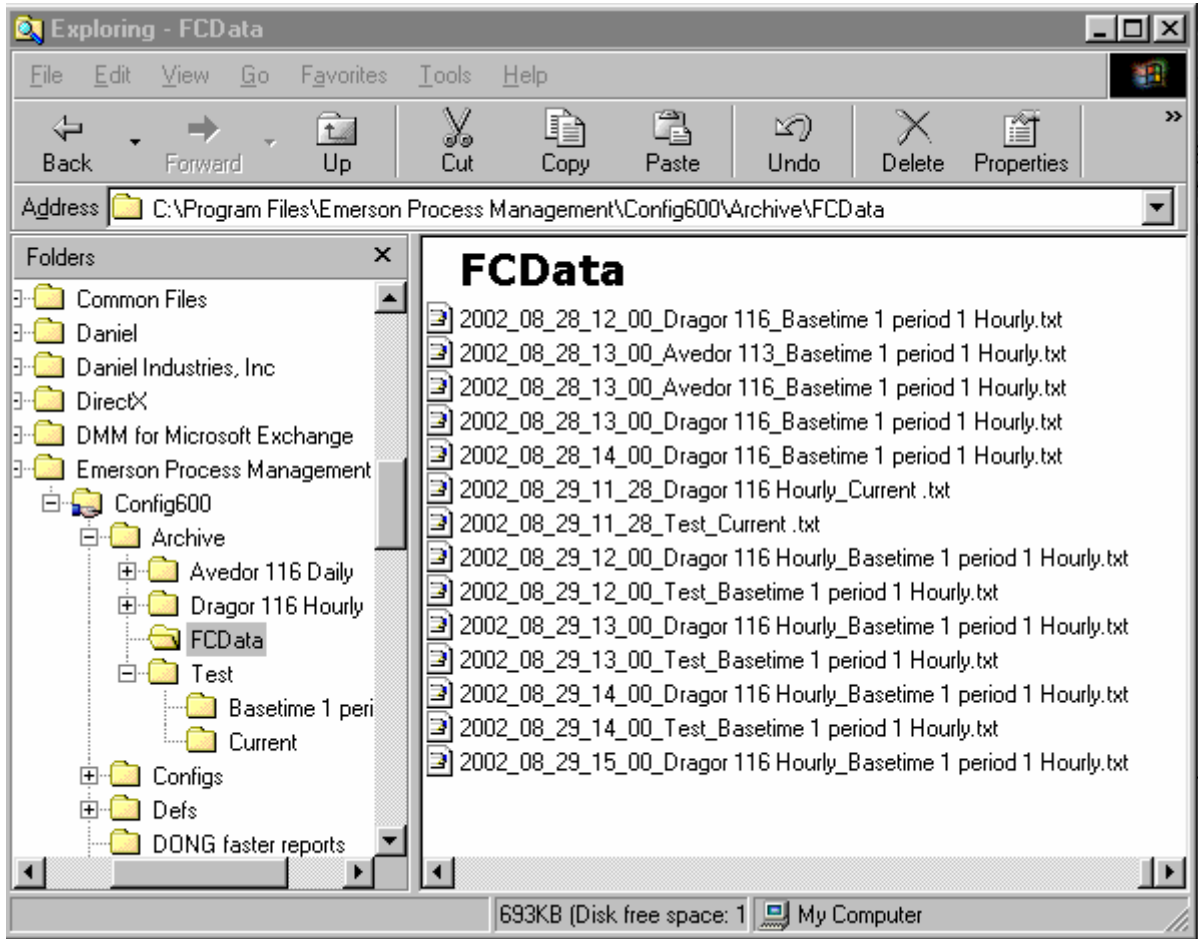

Figure 11-13. Compact Folder Format

---

**Note:** Since the entry in New Flow Computer manual option uses the default communications settings **and** forms part of the file name, take great care in using this option: you can **accidentally overwrite** files from other computers.

---

**Extended Folder Formats** Select **Tools > Extended Folder Format** to enable files uploaded through either manual or automatic operation, to be automatically stored in individual folders as named by the manual load options or the Flow Computer List.

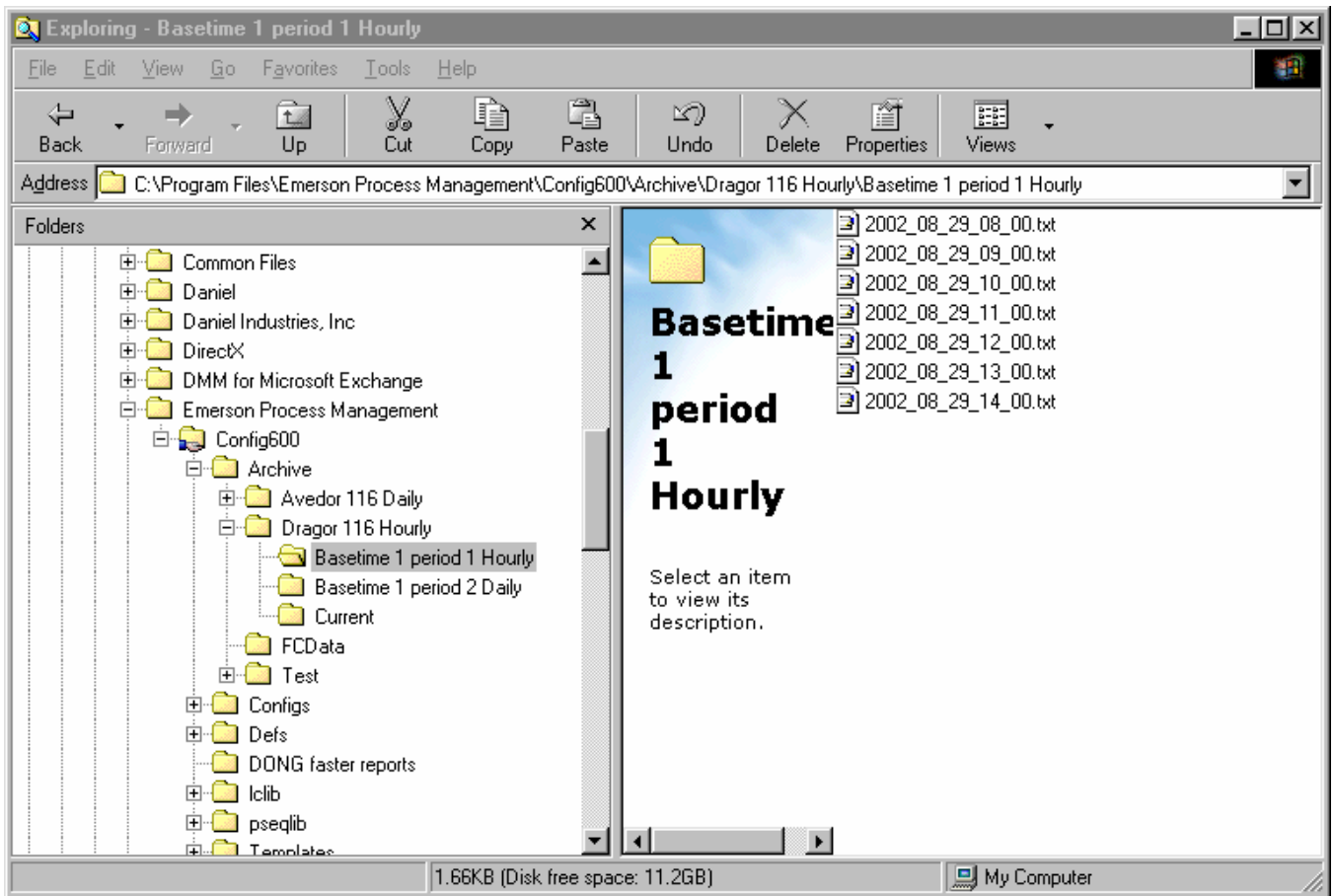

Figure 11-14. Extended Folder Format

---

**Note:** Config600 creates the Basetime 1 period 1 and 2 folders and places archived reports as text files in these folders.

---

### 11.5.5 Data Integrity

The package carries out checks to ensure integrity of data transfers as follows.

Field	Description
<b>File Size</b>	All files are checked to ensure they have a non-zero size. Any Zero sized files are deleted. This will appear in the error log. Due to differences in file sizes, only the Zero size is checked.
<b>Comm Fail</b>	Any file in transit if a COMMS FAIL alarm is detected is deleted irrespective of its file size. This appears in the error log. Failures include: <ul style="list-style-type: none"> <li>▪ Slave fails to respond.</li> <li>▪ Slave sends exception reply.</li> <li>▪ CRC fail.</li> <li>▪ PC cannot connect to port or socket.</li> </ul>

Field	Description
File Names	Any files that do not match those you configure in the Flow Computer List display in the error log.

## 11.6 Printing the Report

This section details how to print reports.

### 11.6.1 Print

To print the report select **File > Print**. The Windows Print screen displays

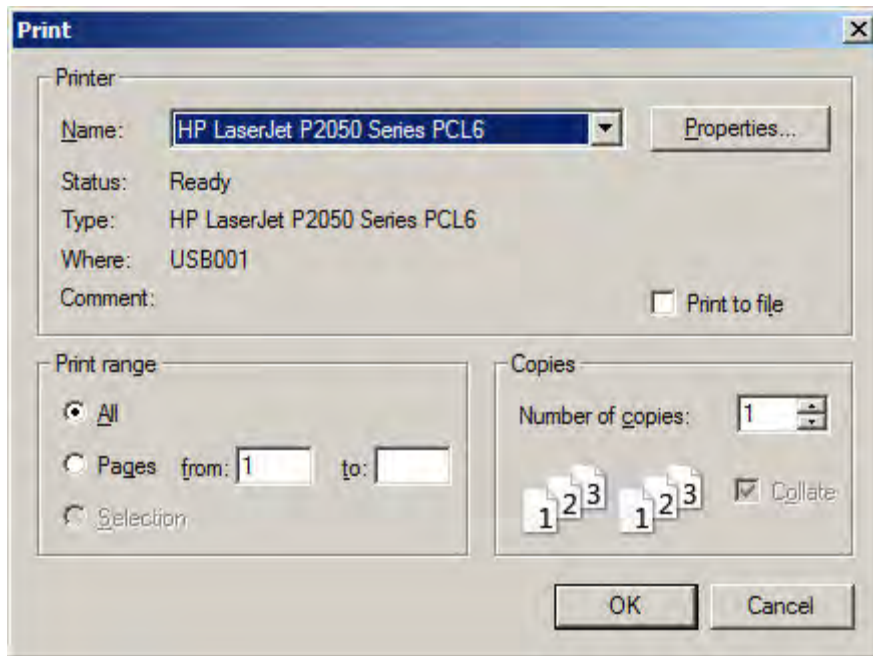

Figure 11-15. Print dialog

### 11.6.2 Print Preview

To display a preview of the report before you print it:

1. Select **File > Print Preview**. The Print Preview screen displays.

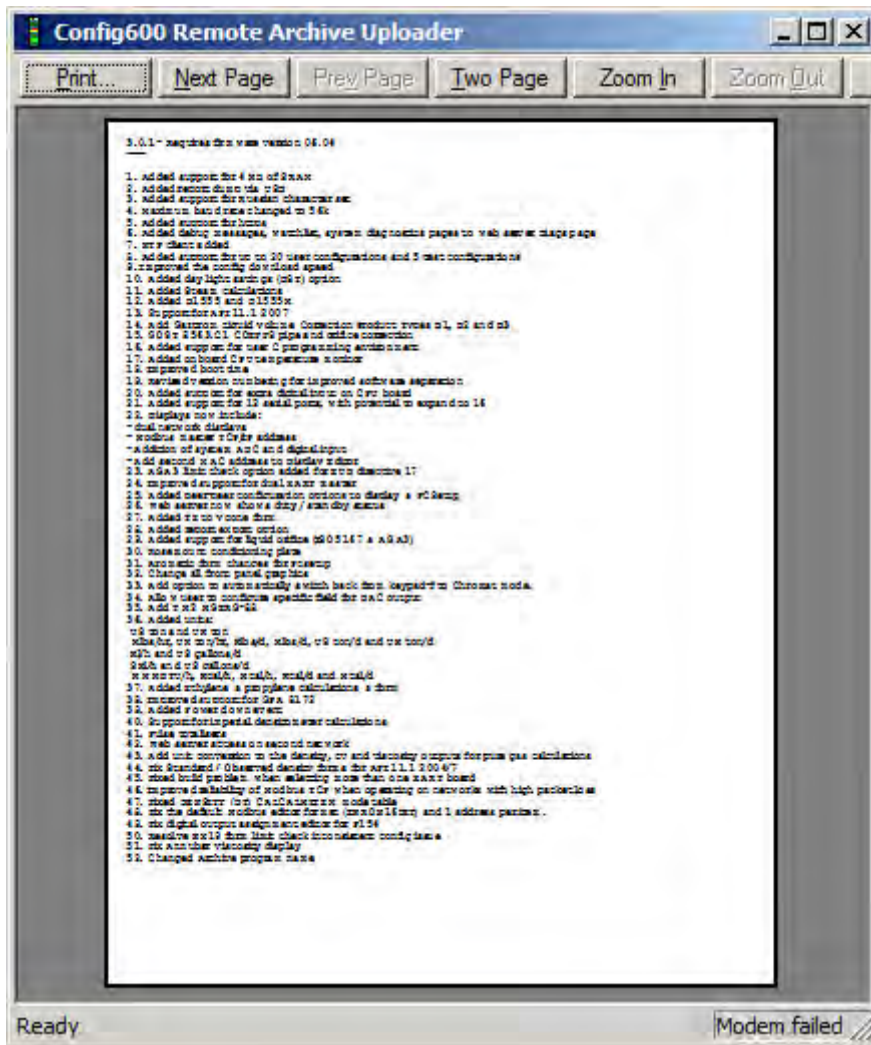

Figure 11-16. Print Preview

2. Review the values for in the following fields:

Field	Description
Print	Click to print the report.
Next Page	Click to see the next page in the report.
Previous Page	Click to see the previous page in the report.
Two Page	Click to see the report in a two page layout side-by-side.
Zoom In	Click to zoom in on the report to make it larger.
Zoom Out	Click to zoom out on the report to make it smaller.

### 11.6.3 Print Setup

To display and configure the Print dialog, select **File > Print Setup**. The Print Setup screen displays:

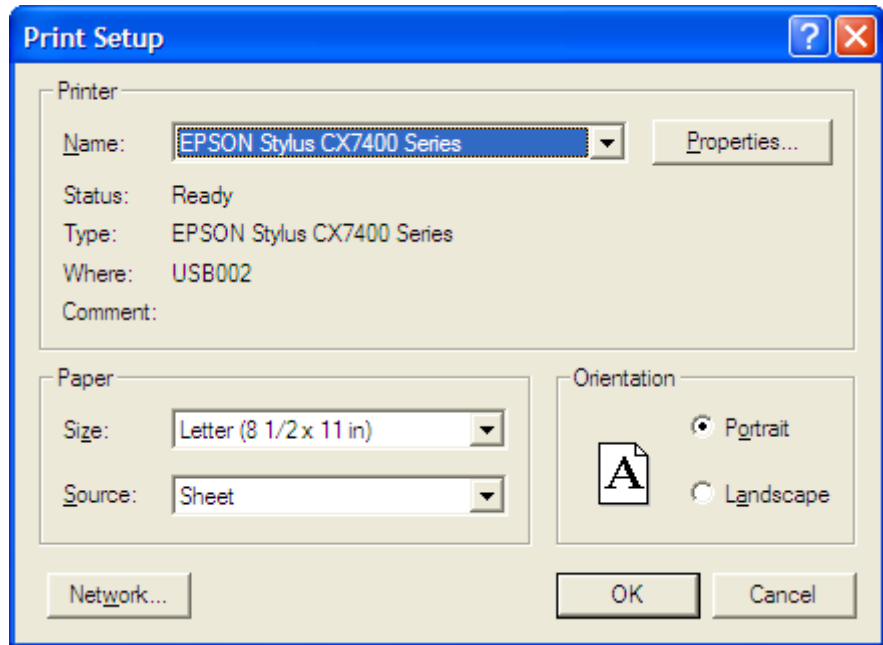

Figure 11-17. Print Setup

Review (or change as necessary) the fields on this screen and then click **OK** to accept the changes.

## 11.7 Abort Transfer

---

Select **Tools > Abort Transfer** to stop data from being transferred between the Remote Archive Uploader and the S600+.

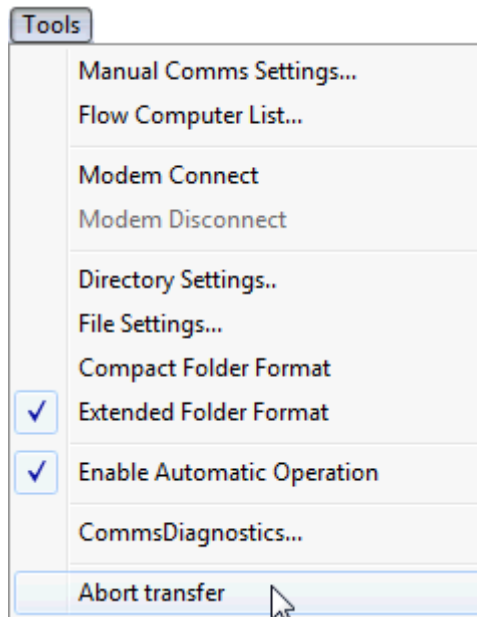

Figure 11-18. Abort Transfer



## Chapter 12 – Report Editor

### In This Chapter

12.1	Accessing the Report Editor.....	12-2
12.1.1	Via PCSetup.....	12-2
12.1.2	Via Report Editor.....	12-3
12.1.3	Report Names.....	12-5
12.2	Using the Report Editor.....	12-6
12.2.1	Adding a Data Point.....	12-7
12.2.2	Editing a Data Point.....	12-9
12.2.3	Adding Report Lines.....	12-9
12.2.4	Deleting Report Lines.....	12-10



The Report Editor is a Windows-based tool that is a part of the Config600 software suite. The Report Editor enables you to modify the reports that you have defined in the S600+ configuration. The Report Editor allows you to add both background text and data points, therefore enabling the generation of completely customized reports.

Reports have a maximum of 80 characters per line. The system automatically numbers each report using a “docket number” system that maintains up to 65,536 unique reports. The docket number starts at 0 and increments to 65535. When the numbering reaches 65535, the numbering system restarts at 0 and replaces the report with the original docket number 0.

You can use the Report Editor to modify the format of current, period, and batch reports, which either print upon trigger events you define or appear on the webserver. However, you **cannot** use the Report Editor to change the format of constant logs, display dumps, security dumps, alarm dumps, config reports, Modbus maps, or help text.

The procedures in this chapter describe how to change the fields and text in the body of reports. You configure basetime and other report parameters on the **System Setup > Reports** screen.

---

**Note:** Because the reports do not affect the metering accuracy of the S600+, changing the report layout does not increase the Config Version of the selected configuration.

---

The PCSetup Editor has been modified to integrate with the Report Editor. PCSetup generates only new reports that have been added and deletes any that have been removed. This allows the Report Editor to edit the reports directly in the main reports folder without the intervention of PCSetup.

Period total indexes are fixed for any particular stream, period, and index to ensure the integrity of the database. Config600 uses a formula to generate an index from these variables, and adding or removing reports does not change any other indexes. The period total indexes can be referenced in the reports.

## 12.1 Accessing the Report Editor

You access the Report Editor either as a selection from the PCSetup Editor or as its own application.

### 12.1.1 Via PCSetup

While you are using the PCSetup Editor, this method enables you to select a specific report you have already defined and stored in the current configuration.

1. From the PCSetup Editor hierarchy, select **System Setup > Reports**. The Reports screen displays.

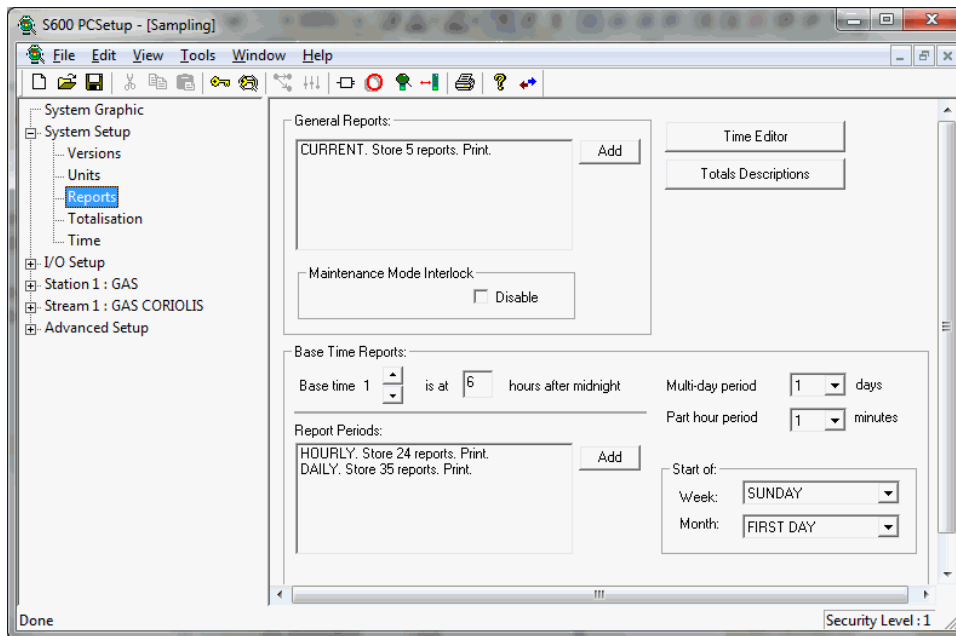

Figure 12-1. PCSetup Reports screen

---

**Note:** If you have more than one version of Config600 on your machine, select the version appropriate to the configuration file.

---

2. Select a report from either the General Reports or the Base Time Reports pane. Config600 adds **Configure**, **Edit**, and **Delete** buttons next to the report listing.

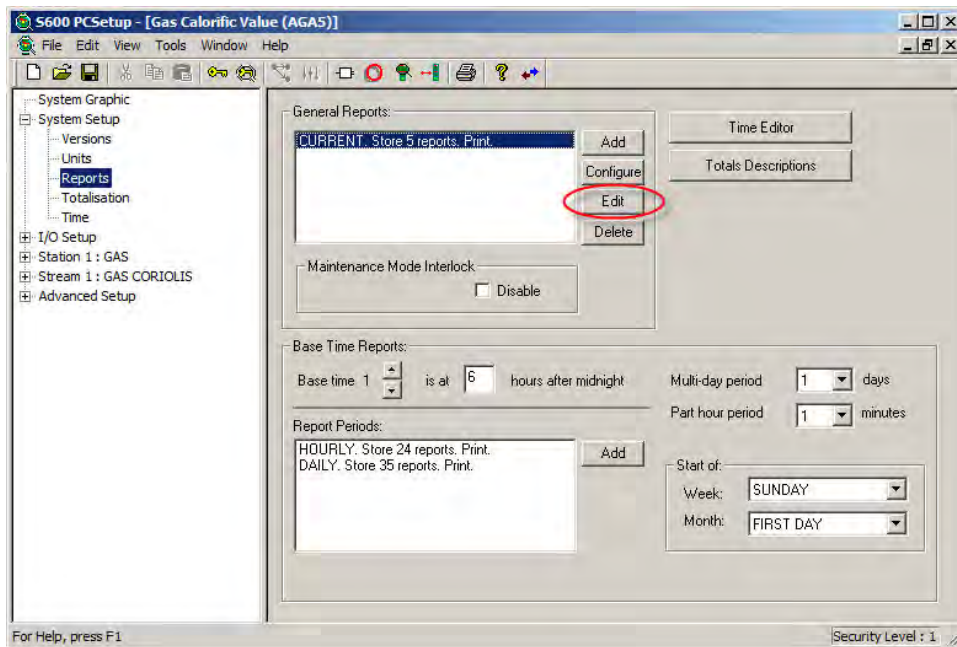

Figure 12-2. PCSetup Reports screen with Edit button

3. Click **Edit**. The Report Editor opens, displaying the selected report.

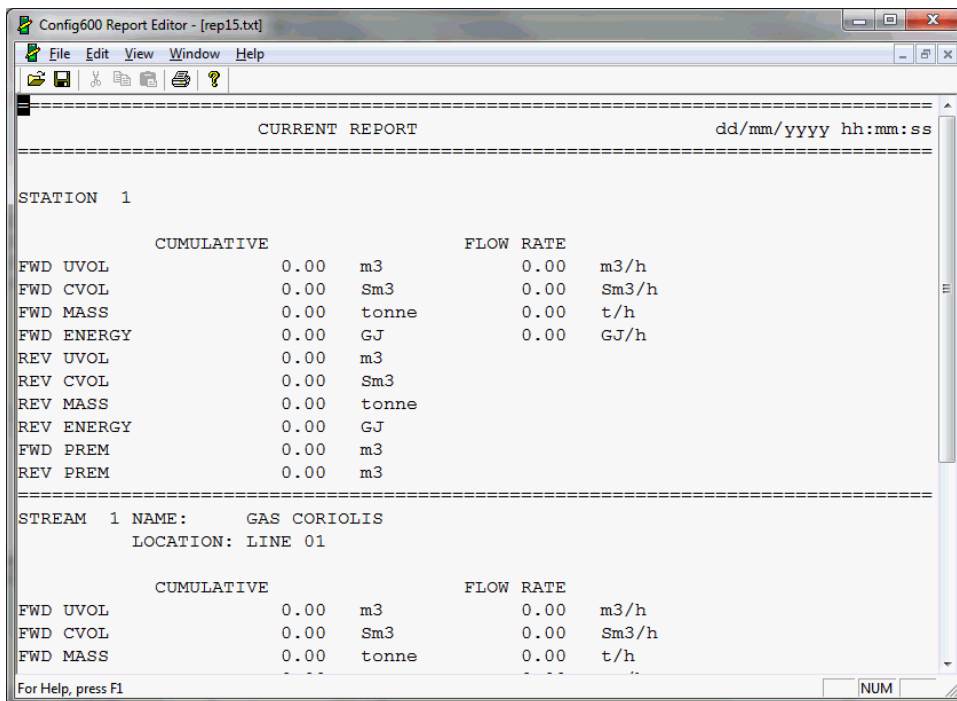

Figure 12-3. Report Editor

### 12.1.2 Via Report Editor

Use this method to open the Report Editor application independently of the PCSetup Editor.

1. Click **Start > All Programs > Config600 3.3 > Report Editor**. A Select Config dialog displays.

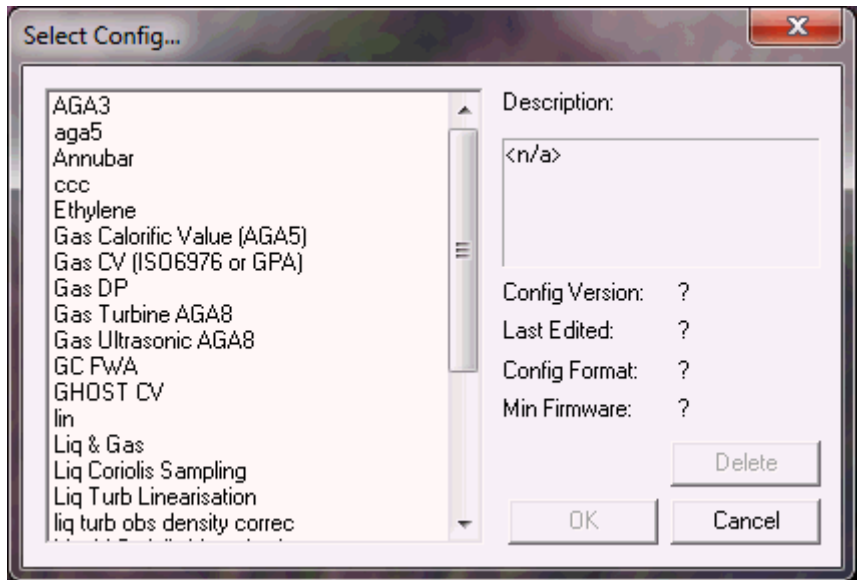

Figure 12-4. Select Config dialog

2. Select a configuration. Note that Config600 completes the information fields for the selected configuration.

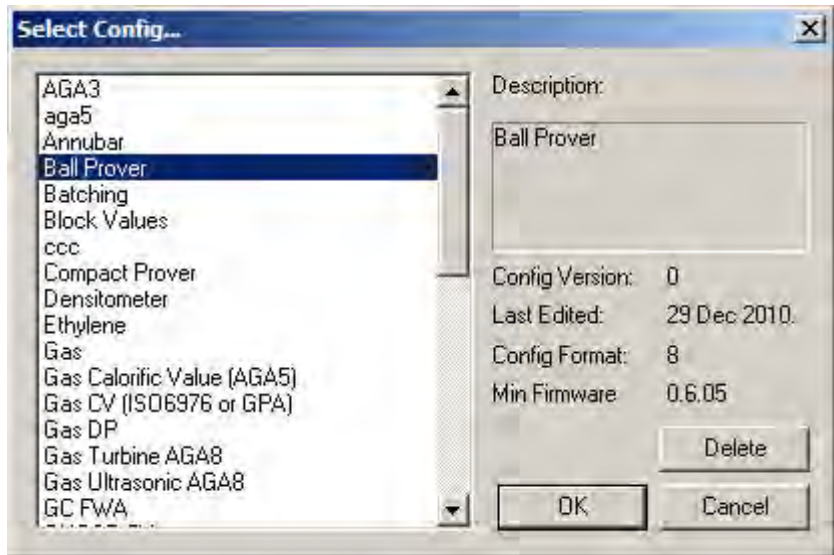

Figure 12-5. Select Config dialog

3. Click **OK**. Config600 loads **all** of the reports defined within that configuration file and displays the first report on the Report Editor screen. Note that the screen's title bar now displays the report name (**rep8.txt**, in this case).

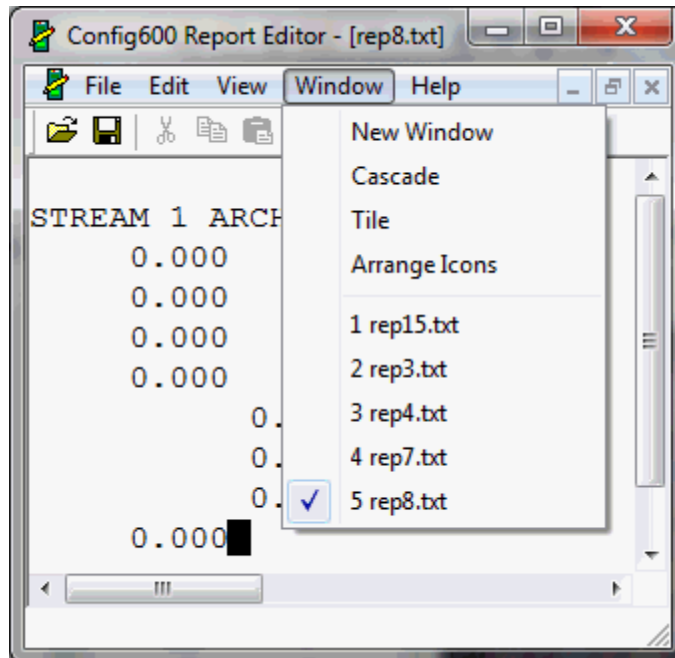

Figure 12-6. Report Editor screen (populated)

---

**Note:** By default, Report Editor displays the rep8.txt report first. To display a list of all currently defined reports within this configuration file, click the Window option on the menu bar.

---

### 12.1.3 Report Names

Config600 uses the following naming convention for the report files. You cannot change these report file names, which are listed so you can locate them in the Reports directory, if necessary.

Report File Name	Description
rep00.txt	Fixed Hourly Report
rep01.txt	Batch Report
rep02.txt	Maintenance Report
rep03.txt	Base Time 1 – Period 1 Report
rep04.txt	Base Time 1 – Period 2 Report
rep05.txt	Base Time 1 – Period 3 Report
rep06.txt	Base Time 1 – Period 4 Report
rep07.txt	Base Time 2 – Period 1 Report
rep08.txt	Base Time 2 – Period 2 Report
rep09.txt	Base Time 2 – Period 3 Report
rep10.txt	Base Time 2 – Period 4 Report
rep11.txt	Base Time 3 – Period 1 Report
rep12.txt	Base Time 3 – Period 2 Report
rep13.txt	Base Time 3 – Period 3 Report
rep14.txt	Base Time 3 – Period 4 Report
rep15.txt	Current Report

Report File Name	Description
rep16.txt	Stream Prover Volume Report <b>Note:</b> Previous versions of the Config600 software grouped the Prover Volume report and the Prover Mass report in one report, rep16.txt.
rep17.txt	Stream Prover Mass Report
rep18.txt	Station 1 Prover Volume Report
rep19.txt	Station 1 Prover Mass Report
rep20.txt	Station 2 Prover Volume Report
rep21.txt	Station 2 Prover Mass Report
rep22.txt	CHR D/LOAD
rep23.txt	CHR TELEMETRY
rep24.txt	BATCH TICKET
rep25 – rep39.txt	User defined reports

## 12.2 Using the Report Editor

Regardless of the access method, once you open the Report Editor you can begin using it to modify the format and content of your reports.

You select editing functions from a pop-up menu, which displays when you right-click any part of the Report Editor screen:

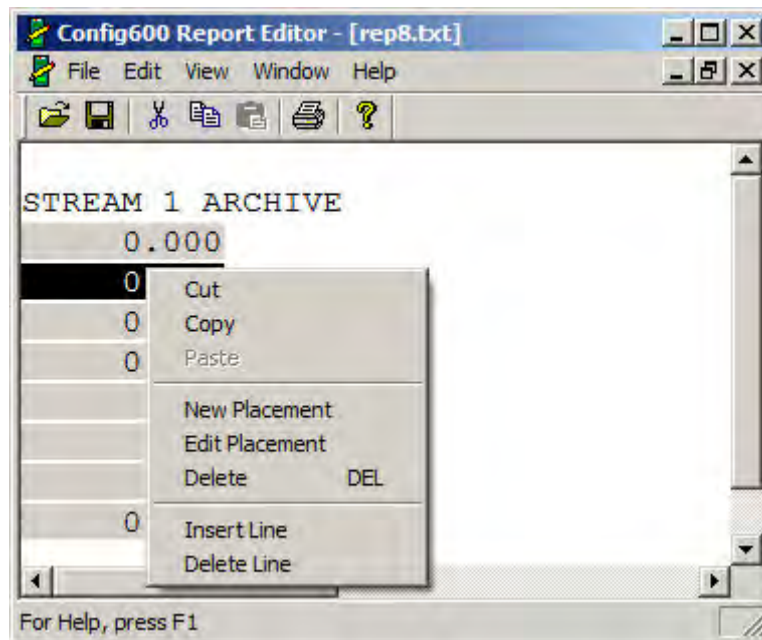

Figure 12-7. Report Editor menu

**Note:** You can also access this menu by selecting **Edit** from the menu bar.

The menu provides these options:

Option	Description
<b>Cut</b>	Removes the selected element from the report and places it on the Clipboard.
<b>Copy</b>	Copies the selected element from the report and places it on the Clipboard.
<b>Paste</b>	Places content from the Clipboard to the cursor's location.
<b>New Placement</b>	Accesses the Placement Editor, which you use to define a new data point (see <i>Section 12.2.1, Adding a Data Point</i> ).
<b>Edit Placement</b>	Accesses the Placement Editor, which you use to edit a current data point.
<b>Delete</b>	Removes the selected element from the report without placing it on the Clipboard.
<b>Insert Line</b>	Adds a line to the report at the cursor's current position.
<b>Delete Line</b>	Removes the selected line from the report.

**Note:** The Report Editor does not provide an “undo” function. Once you have deleted a report element or a line, you cannot restore it. You must recreate it.

## 12.2.1 Adding a Data Point

Use this procedure to add a data point field to the selected report.

1. Place the cursor where you want to insert the new data point.
2. Right-click and select **New Placement** from the shortcut menu. The Placement Editor dialog box displays.

**Note:** You can also select **Edit > New Placement** from the menu bar.

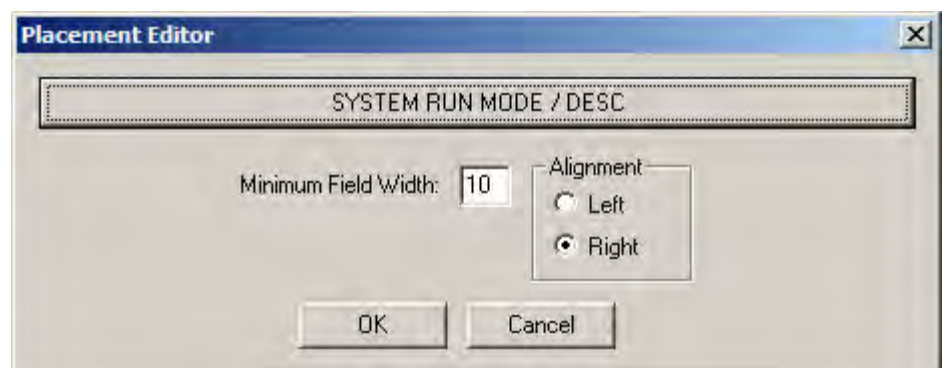

Figure 12-8. Placement Editor

3. Click **System Run Mode / Desc** to select a data point. The Connect Wizard displays.

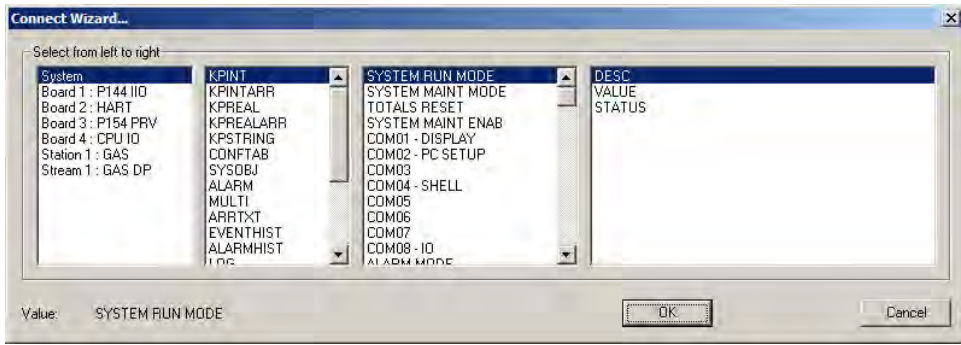

Figure 12-9. Connect Wizard

4. Define the new data point by highlighting values in each of the four columns. Select from left to right. You can click ▼ or ▲ to display more values. Refer to *Appendix E, S600+ Database Objects and Fields* for additional information.
5. Click **OK** once you have defined the new data point. The Placement Editor dialog box re-displays. Note that the label on the button now reflects the choices you made using the Connect Wizard.

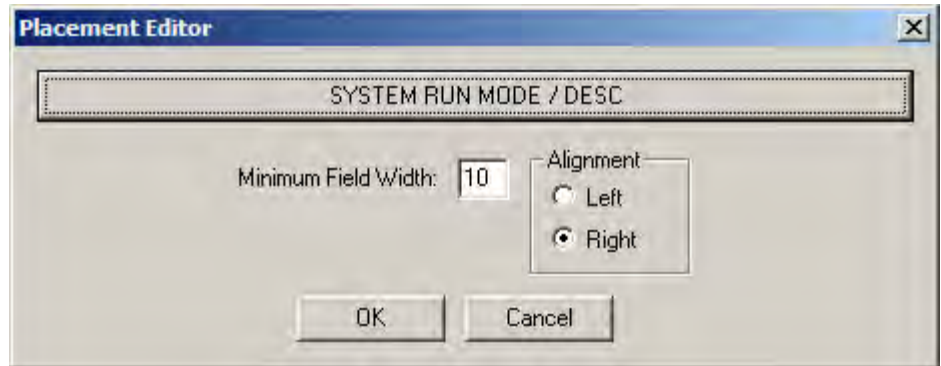

Figure 12-10. Placement Editor with revised label

6. Complete the following fields on the Placement Editor dialog box:

Field	Description
<b>Minimum Field Width</b>	Indicates the number of characters reserved for the data item, counted to the right of where you placed the data item. If the number or text exceeds the minimum field width, the data item automatically expands to the right.
<b>Alignment</b>	Indicates whether the data point aligns to the left or right of the placed position.

7. Click **OK** to apply your new data point definition to the report file. The report file displays, showing your new data point.



## 12.2.2 Editing a Data Point

Use this procedure to edit an existing data point field on the selected report.

1. Select an existing data point and right-click. The edit pop-up menu displays.
2. Select **Edit Placement**. The Placement Editor dialog box displays.

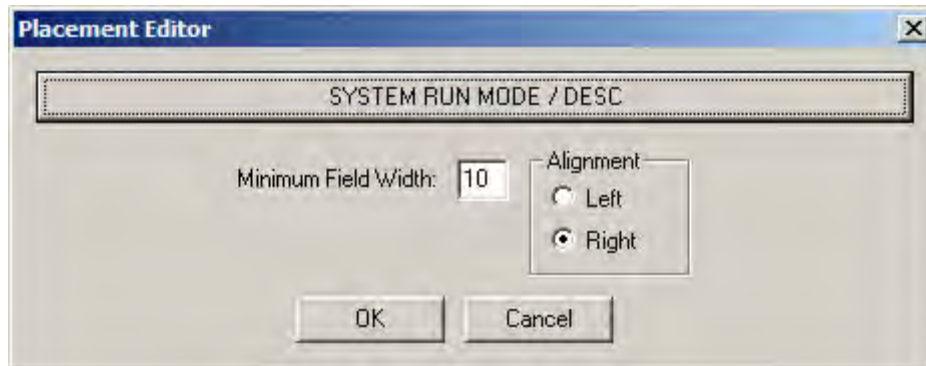

Figure 12-11. Placement Editor dialog box

3. Click the button at the top of the dialog box. The Connect Wizard displays.

**Note:** The label on this button changes depending on the data point you select.

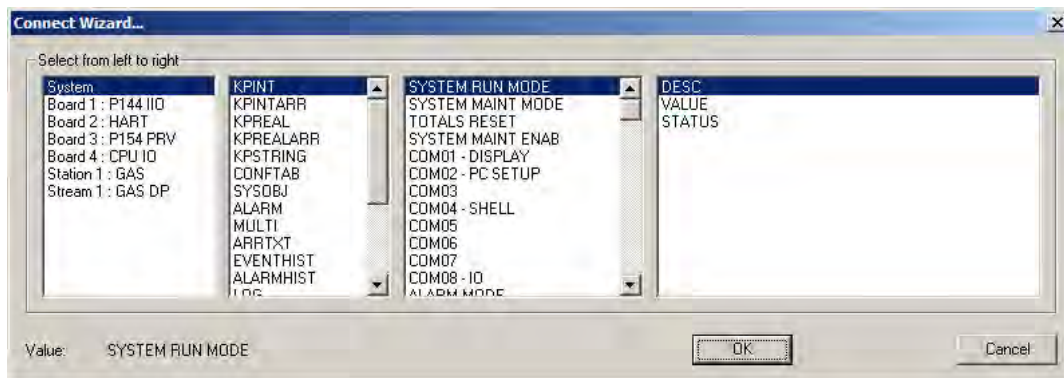

Figure 12-12. Connect Wizard

4. Modify the selections on the Connect Wizard as necessary.
5. Click **OK** when you finish. The Placement Editor dialog box displays.
6. Click **OK** to apply your changes to the data point. The report file displays.

## 12.2.3 Adding Report Lines

Use this procedure to insert a new line on the report.

1. Place the cursor where you desire to insert the new line.

2. Right-click and select **Insert Line** from the shortcut menu.  
Config600 adds a blank line to the report above the cursor position.

### 12.2.4 Deleting Report Lines

Use this procedure to delete a line from the report.

1. Place the cursor on the desired line.
2. Right-click and select **Delete Line** from the shortcut menu.  
Config600 removes the line from the report.



**Caution**

**This editor does not provide an “undo” facility. Once you delete a report line, you cannot restore it. You must rebuild it.**

---

## Chapter 13 – Display Editor

### In This Chapter

13.1	Accessing the Display Editor.....	13-1
13.2	Navigating the Display Editor.....	13-2
13.3	Editing.....	13-3
13.3.1	Insert Menu.....	13-5
13.3.2	Insert/Append Page.....	13-5
13.3.3	Edit Line.....	13-5
13.3.4	Translate.....	13-7
13.3.5	Save.....	13-8
13.3.6	Menu/Page Clipboard.....	13-8
13.4	Regenerating Displays.....	13-8



The S600+ Display Editor allows you to customize the visual display on your S600+'s front panel. The Display Editor provides a graphical "what-you-see-is-what-you-get" (WYSIWYG) feel for the final appearance of the front panel and the navigation of your configuration in the S600+. The Display Editor presents your configuration, allowing you to view the actual data point initialization values for your specific application.

**Note:** The Display Editor front panel does **not** display live data from the S600+.

### 13.1 Accessing the Display Editor

You can start the Display Editor in any of three ways:

- Click the Edit Displays icon  on the PCSetup Editor's tool bar. The Display Editor menu displays.
- Select **Tools > Edit Displays** from the PCSetup Editor's Menu bar.
- Click **Start > All Programs > Config600 3.3 > Display Editor**. You select a configuration from the Select Config dialog box. The Display Editor menu displays.



**Caution**

**Because of the way S600+ creates and saves displays, you should edit displays only after you have finished creating the configuration file. This ensures the inclusion of any changes to the configuration.**

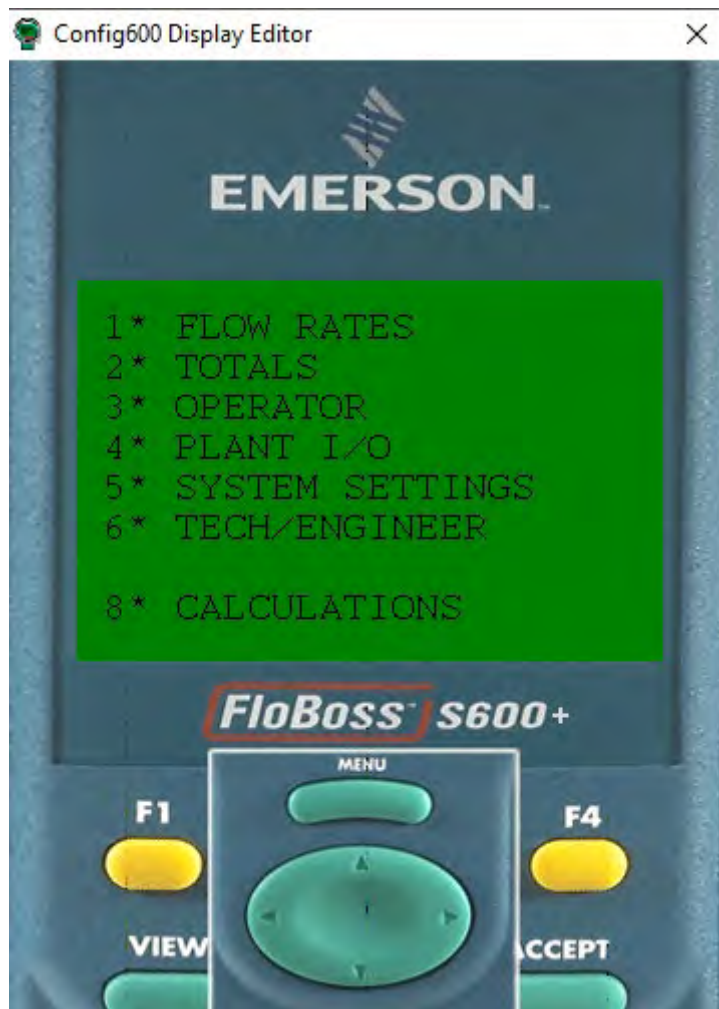

Figure 13-1. Display Editor main menu screen

## 13.2 Navigating the Display Editor

To navigate through the Display Editor, click menu options 1 through 6 and 8. To move back up through the menus, click the menu button or the 4-direction arrow key. These keys behave just as they do on the S600+ front panel itself. Refer to *Chapter 5* in the *FloBoss S600+ Flow Computer Instruction Manual* (part D301150X412) for more details on front panel navigation.

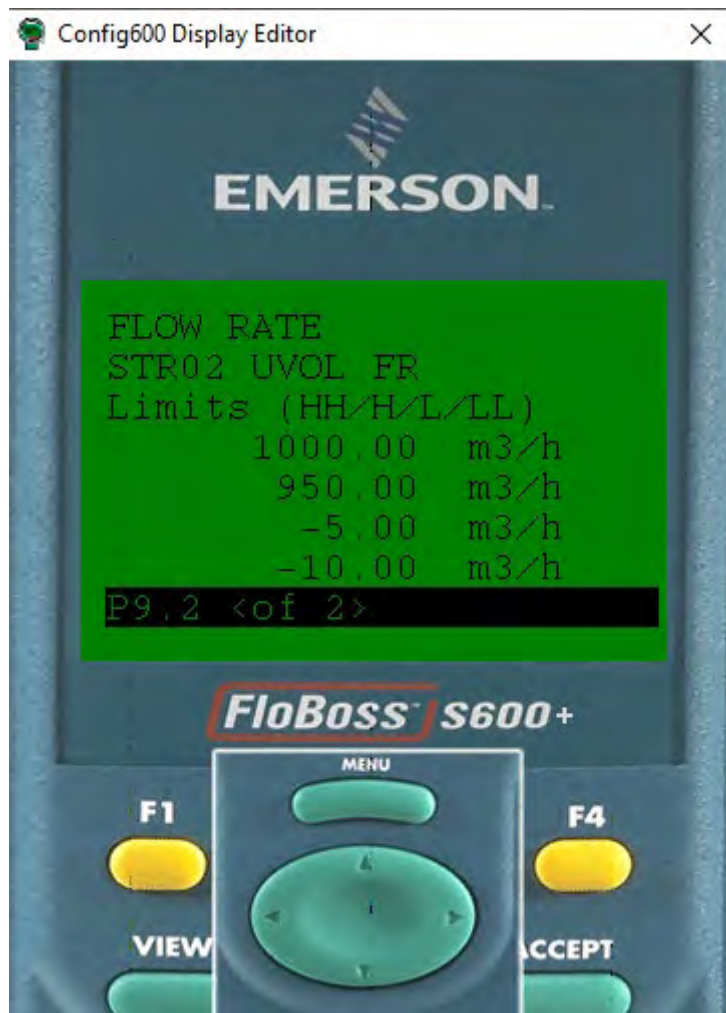

Figure 13-2. Typical Display Page (Stream 2 Flow Limits shown)

### 13.3 Editing the Display Editor

To edit the displays:

1. Right-click on a **menu line** to display a shortcut menu.



Figure 13-3. Display Editor with shortcut menu

This menu provides the following options:

Option	Description
<b>Insert Menu</b>	Creates a submenu.
<b>Insert Page</b>	When you select Insert Page from a menu, the Display Editor creates and inserts a page link at the position of the cursor. When you select Insert Page from a page, the Display Editor creates and inserts a page before the selected page.
<b>Append Page</b>	Creates and inserts a page after the selected page.
<b>Edit Line</b>	Edits the selected line.
<b>Translate</b>	Re-indexes the placements on the displays to use an alternative stream or station selection, such as to change stream objects from their current stream selection to the equivalent selection in another stream.
<b>Save</b>	Saves any modifications you have made to the configuration file.
<b>Menu/Page</b>	Cut, copy, delete or paste the menu item or page link.
<b>Help</b>	Accesses the online help for the Display Editor.

Config600 grays out any options that do not apply to the selected item.

### 13.3.1 Insert Menu

To create a new menu, right-click on any empty menu slot and select **Insert Menu**.

The S600+ can display more than eight options in a menu. However, unless the menu already has eight or more options, you cannot currently add more options.

---

**Note:** If you create empty menus while editing, the S600+ does not display them because the Display Editor automatically removes them on startup.

---

### 13.3.2 Insert/Append Page

To create a new page, right-click on any empty menu slot. You can add a new page to an existing menu option by navigating to a page on that row, right-clicking, and selecting either **Insert Page** (to create a page **before** the current one) or **Append Page** (to create a page **after** the current one).

The S600+ can display more than eight options in a menu. However, due to technical limitations with the Display Editor, you cannot add more options. Contact technical support personnel if you need to add more options.

### 13.3.3 Edit Line

To edit an existing line in the display menu:

1. Right-click on the required line and select **Edit Line**. The Edit dialog box displays.

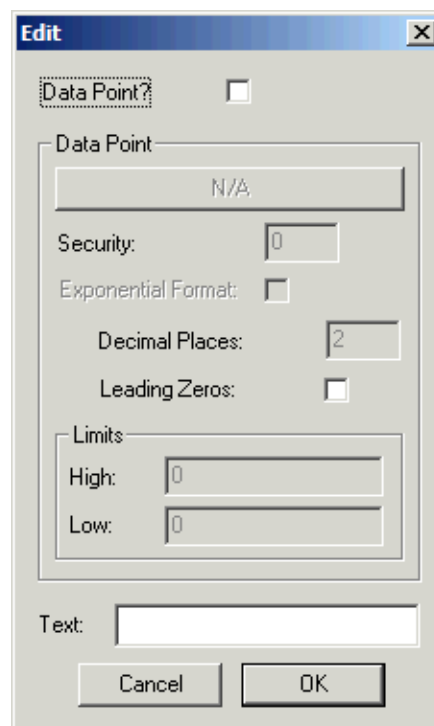

Figure 13-4. Edit dialog box

2. If the line contains **only text**, use the **Text** field to change the displayed description.

**Note:** The description **cannot** contain any commas (,).

3. Click **OK** when you are finished. The menu displays, showing your edit.
4. If the line contains a data point **or** you want to place a data point on a blank line, select the **Data Point** checkbox. Config600 activates the rest of the Edit dialog box.

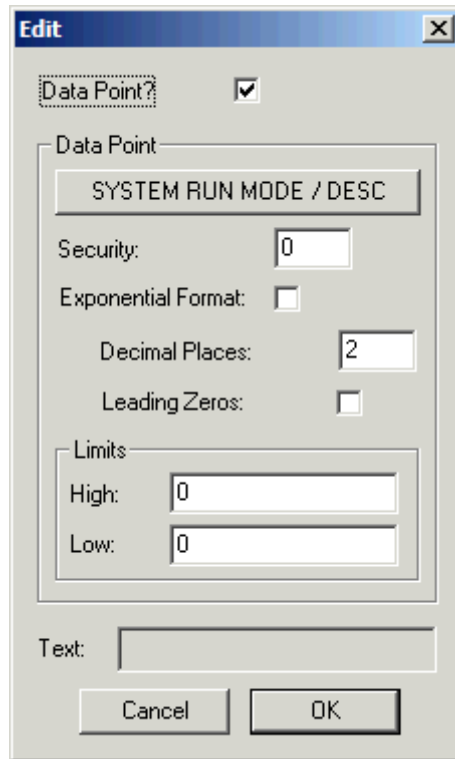

Figure 13-5. Edit dialog box

5. Click the **Data Point** button at the top of the Data Point pane to define a data point. The Connect Wizard displays.

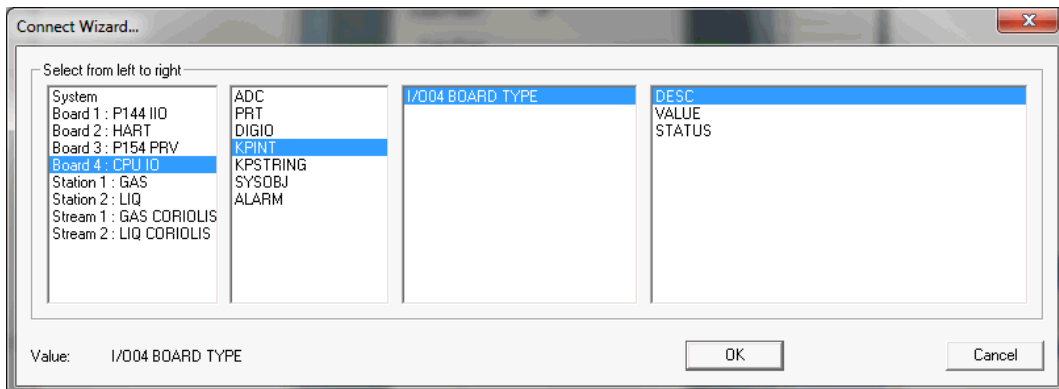

Figure 13-6. Connect Wizard



6. Define the new **data point** by highlighting values in each of the four columns (object source, object type, object, object field). Select from left to right. Click ▼ or ▲ to display more values.

**Note:** Refer to *Appendix E, S600+ Database Objects and Fields*.

7. Click **OK** when you have finished. The Edit dialog box displays.
8. Complete, as necessary, the remaining fields on the Edit dialog box.

Field	Description
<b>Security</b>	Indicates a security Level (0 to 9) for the field. <b>Note:</b> The default is <b>0</b> (cannot be changed).
<b>Exponential Format</b>	Select to indicate the representation of numbers in an exponential format. <b>Note:</b> If you select this checkbox, S600+ greys out the Decimal Places and Leading Zeroes fields.
<b>Decimal Places</b>	Indicates the number of decimal places required for the selected field.
<b>Leading Zeroes</b>	Select to indicate whether leading zeroes are required for this field.
<b>High Limit</b>	Indicates the high (maximum) limit for the value in this field.
<b>Low Limit</b>	Indicates the low (minimum) limit for the value in this field.

9. Click **OK** when you have finished defining the field. The Display Editor displays, showing the new value you have defined.

### 13.3.4 Translate

This shortcut menu option allows you to translate or copy a menu structure for one stream or station into that for another stream or station. To translate a menu structure:

**Note:** The Translate function **only** translates stream or station data.

1. Build the display structure you require for one stream or station. (This is the “model” structure.)
2. Right-click on another line and select **Translate**. The Translate dialog box displays.

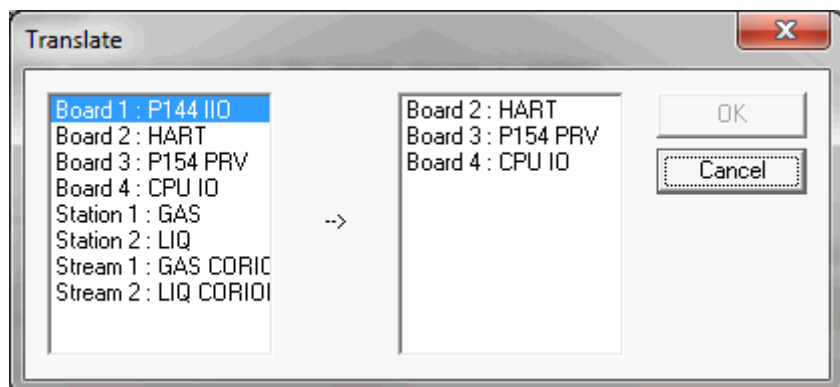

Figure 13-7. Translate dialog box

3. Select a **model** stream or station from the left-hand column and a **target** stream or station in the right-hand column. Config600 activates the **OK** button when you identify a target stream or station.
4. Click **OK** to apply the model structure to the target stream or station.

### 13.3.5 Save

If you have changed any display content, Config600 gives you the option of saving your changes through the Save option on the shortcut menu. Establishing the habit of saving your work frequently is a highly recommended practice.

### 13.3.6 Menu/Page Clipboard

The Display Editor has a built-in clipboard that can store any number of menus and/or pages. This enables you to copy or move menus and pages by right-clicking and using the shortcut menu.

- To copy a page to the clipboard, navigate to that page and select **Menu/Page > Copy** from the shortcut menu.
- To copy a whole row of pages to the clipboard, navigate to the menu above the row of pages, right-click on the title of the row of pages, and select **Menu/Page > Copy**.
- To copy a menu structure complete with all submenus and pages, navigate to the menu above the menu structure you wish to copy, right-click on the menu title required, and select **Menu/Page > Copy**.

Deleting and cutting menus and pages is the same as copying but you select **Menu/Page > Delete** or **Menu/Page > Cut**. A Cut is similar to a Delete, except that the action places the deleted items on the clipboard.

Once you have a page or a row of pages on the clipboard, you can paste them either to an empty menu slot or into an already existing row of pages.

To paste the page(s) to an empty slot, right-click on an empty menu slot and select **Menu/Page > Paste**.

To paste the page(s) into an already existing row of pages, navigate to an already existing page and select **Menu/Page > Paste**. Config600 pastes a copy of the page or pages on the clipboard after the current display in the page row.

When you have a menu structure in the clipboard, you can paste it into any empty menu slot by right-clicking on it and selecting **Menu/Page > Paste**. You cannot paste menu structures into pages or page rows.

---

## 13.4 Regenerating Displays

Using an option in PCSetup, you can restore S600+ displays to the appearance and values as defined in the selected configuration.

**Caution**

**This option overwrites any edits or customisations you may have made to the displays in the selected configuration.**

1. Select **File > Regenerate** from the PCSetup menu bar. The Display and Modbus Regeneration dialog box displays.

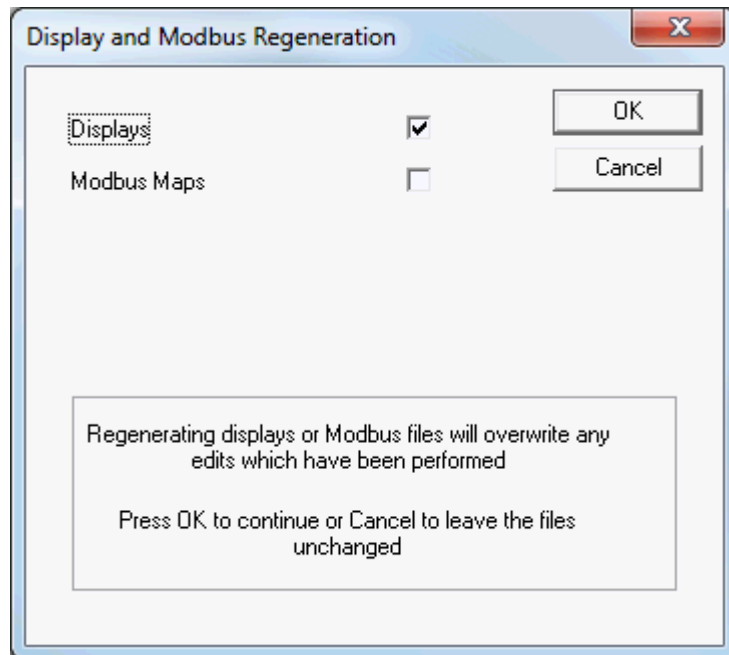

*Figure 13-8. Display Regeneration*

2. Select the **Displays** check box and click **OK**. Config600 restores all S600+ displays to the default values defined in the selected configuration.

*[This page is intentionally left blank.]*

## Chapter 14 – Modbus Editor

### In This Chapter

14.1	Supported Function Codes .....	14-1
14.2	Accessing the Modbus Editor.....	14-2
14.3	Using the Modbus Editor .....	14-2
14.4	Map Properties .....	14-3
14.4.1	Insert a Data Point.....	14-5
14.4.2	Quick Insert .....	14-6
14.4.3	Insert Special.....	14-6
14.4.4	Insert Special.....	14-7
14.4.5	Delete a Data Point.....	14-8
14.4.6	Edit Modbus Format.....	14-8
14.4.7	Insert a Message.....	14-10
14.4.8	Insert a Slave.....	14-12
14.5	Regenerating Maps .....	14-13



The Modbus protocol is the standard communications interface to the S600+. The protocol is based on Gould/Modicon Modbus. The S600+ supports Modbus, Modbus Enron (also referred to as Modbus with EFM Extensions), and Modbus encapsulated in TCP/IP. The FloBoss S600+ supports both slave and master functionality in Modbus and Modbus Enron, and slave functionality in Modbus encapsulated in TCP/IP.

Modbus is the Config600 software interface to the S600+. This communications link uses Function Code 65, with specially designed sub-functions to provide file transfer, system edit commands, and other specialized functionality. The S600+ is the slave on this link.

### 14.1 Supported Function Codes

The Config600 Modbus supports the following function codes.

Function Code	Description
1	Read Output Status
2	Read Input Status
3	Read Output Registers
4	Read Input Registers
5	Read Single Coil
6	Read Single Register
8	Loopback
15	Write Multiple Coils
16	Write Multiple Registers
65	Read Floats (PCSetup only)
66	Write Floats (PCSetup only)
67	Read Doubles (PCSetup only)
68	Write Doubles (PCSetup only)

Modbus fully supports RTU (Remote Terminal Unit) Modbus and ASCII (American Standard Code for Information Interchange) Modbus. In RTU mode, you must configure the link for 8 data bits. No message header or trailer is included. The checksum is the 16-bit CRC

specified in the Gould Modbus specification. No inter-character gaps are required on received RTU Modbus messages.

In ASCII mode, you can set the link to 7 or 8 data bits. The message starts with the ASCII Modbus start character “:” (colon). The checksum is the 8-bit LRC defined in the Gould Modbus specification. The message terminates with the ASCII Modbus trailer characters “CR” then “LF”.

The communications configuration is split into two parts: link configuration for the ten tasks (links) and map configuration. The Modbus map configuration is the assignment of database points and fields to Modbus coils, inputs, and registers. This is accomplished through a text file you build using the Modbus Editor.

## 14.2 Accessing the Modbus Editor

---

You can start the Modbus Editor in either of two ways:

- From the PCSetup Editor’s hierarchy menu, select **I/O Setup > Comms**. Select a Modbus task that includes an Address Map and click **Edit**. The Modbus Editor displays.
- From Windows, click **Start > All Programs > Config600 3.3 > Modbus Editor**. Select **File > Open** and select a configuration file from the Select Config dialog box. The Modbus Editor displays.

---

**Note:** If you have more than one version of Config600 on your machine, select the version appropriate to the configuration file. Starting with Config600 3.1, the system derives the Slave Modbus map from the in-use display file.

---

## 14.3 Using the Modbus Editor

---

The Config600 Modbus Editor enables you to configure the Modbus maps the Config600 sends to the S600+ to allow communications.

Using the Modbus Editor, you create Modbus maps as text files. All Modbus maps must use the naming convention “mbxxxxxx.txt”: file names begin with **mb** followed by six characters of your choosing. The S600+ only recognizes map files that start with **mb**.

---

**Note:** As you edit maps, make sure to save (using either the Save icon or **File > Save**) all modifications to the files.

---

The interface shows the coils, inputs, and registers in spreadsheet-style tables. The editor consists of two panes: a hierarchy menu in the left pane and the tables in the right pane.

**Note:** Addresses that display and that you enter at the S600+ are the actual address transmitted and received within the Modbus messages, they are not pre-processed. Functions are entered separately and are not associated with a specific address range. Each function can access any address.

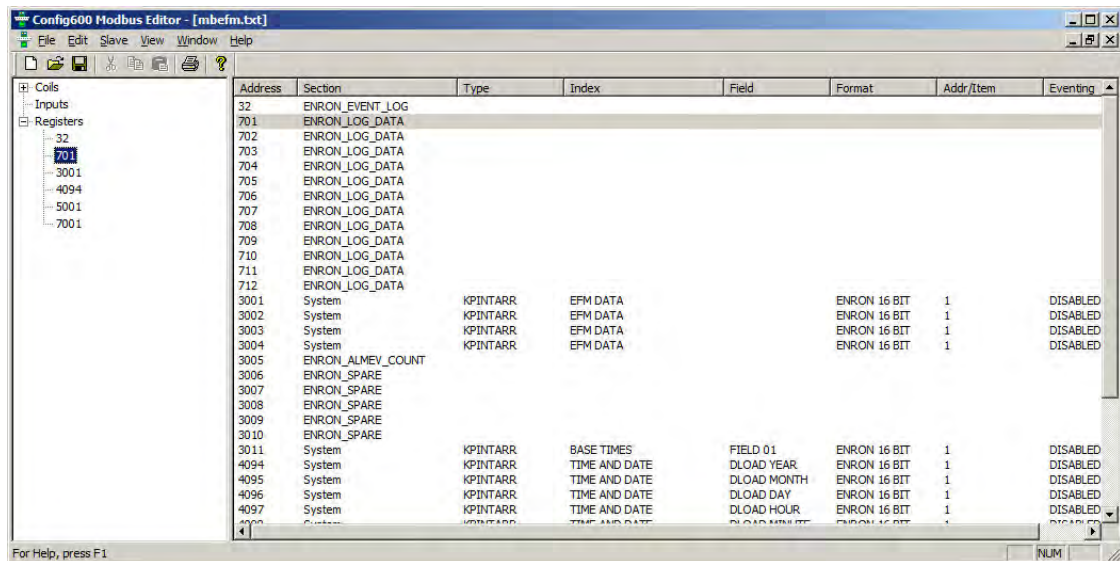

Figure 14-1. Modbus Editor main screen

**Note:** Using the PCSetup Editor's Comms screen (**I/O Setup > Comms**), you can define an entire Modbus map as read-only. This prevents the host PC—or any other computer—from editing or overwriting the map.

## 14.4 Map Properties

Use the Modbus map Properties dialog box to set parameters for the map's .txt file.

1. Select **Register** in the left pane.
2. Select **File > Properties** from the Modbus Editor's menu bar. The Properties dialog box displays.

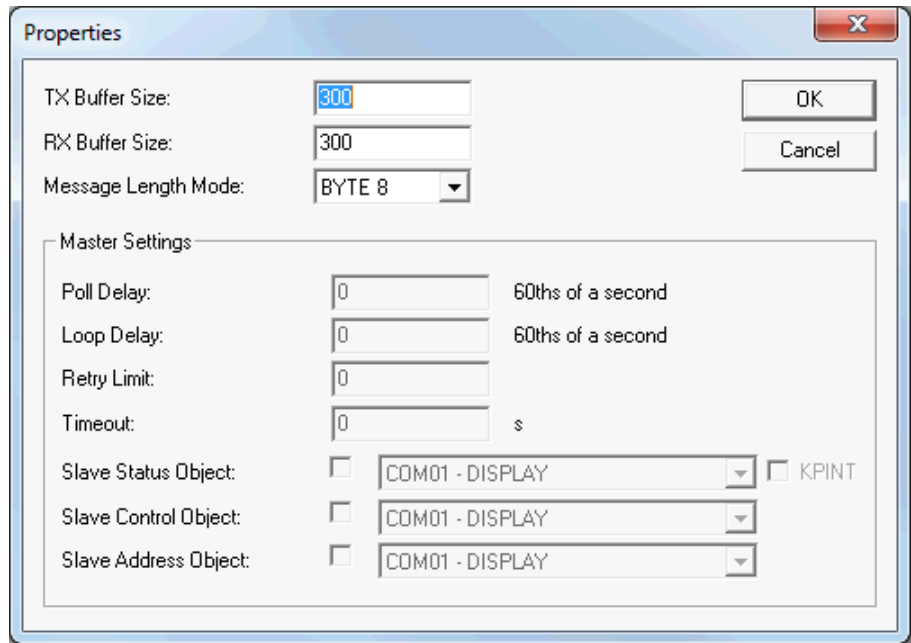

Figure 14-2. Properties dialog box

**Note:** If you selected a slave map to edit, Config600 greys out the Master Settings.

3. Complete the following fields:

Field	Description
<b>TX Buffer Size</b>	Sets, in bytes, the size of the message transmit buffer. Valid values are 256 to 65535. For normal Modbus operation, set this to 256, since this is the maximum message size Modbus supports.
<b>RX Buffer Size</b>	Sets, in bytes, the size of the message receive buffer. Valid values are 256 to 65535. For normal Modbus operation, set this to 256, since this is the maximum message size Modbus supports.
<b>Message Length Mode</b>	Indicates how the system handles the message length section of the Modbus message. Click ▼ to display valid values, which include Byte 8, Byte 16, Item 8, and Item 16.  The basic Modbus specification defines this field as a single byte, which defines the number of bytes of data in the message. Many implementations have changed this field to be an item count, indicating the number of data items in the message.  To increase the amount of data you can transfer, the S600+ supports a 16-bit value for this field. This 16-bit value is not compatible with standard Modbus.  <b>Note:</b> If you use either of the 16-bit formats, messages may be longer than 256 bytes. Adjust the values in the TX Buffer Size and RX Buffer Size fields accordingly.
<b>Poll Delay</b>	Sets, in sixtieths of a second, the delay between system polls.
<b>Loop Delay</b>	Sets, in sixtieths of a second, the delay at the end of a poll loop.
<b>Retry Limit</b>	Sets the number of retries the master polls for a single message before classing it as failed.



<b>Field</b>	<b>Description</b>
<b>Timeout</b>	Sets, in seconds, the amount of time the master waits for a response from the slave.
<b>Slave Status Object</b>	The slave status KPINTARR gives the communication link status of an individual slave on a Modbus master link. Each field of the KPINTARR represents the status of a specific slave. For example, a Modbus master link with three slaves would use FIELD01, FIELD02 and FIELD03 as they appear listed in the Modbus map editor tree view. Note the field number bears no relation to the Modbus slave address. The individual fields can have a value of 0 (healthy), 1 (disabled) or 2 (communication error).
<b>Slave Control Object</b>	The slave control KPINTARR uses to enable or disable an individual slave on a Modbus master link. Each field of the KPINTARR represents the status of a specific slave. For example, FIELD01 enables or disables the first slave as listed in the Modbus map editor tree view. Note the field number bears no relation to the Modbus slave address.
<b>Slave Address Object</b>	The slave address KPINTARR uses to define the Modbus address of an individual slave on a Modbus master link. Each field of the KPINTARR represents the address of a specific slave. For example, FIELD01 contains the address of the first slave as listed in the Modbus map editor tree view.

4. Click **OK** when you have finished. The Modbus Editor screen displays.

### 14.4.1 Insert a Data Point

The Modbus Editor provides three ways to add a data point to the Modbus map:

- **Quick Insert** (base new data point entirely on selected data point).
- **Insert Special** (define new data point by using the Enter Details and Choose dialog boxes).
- **Insert** (do not base new data point on selected data point; use the Enter Details dialog box and Connect Wizard to define data point components).

---

**Note:** Regardless of the method you select, be sure to save the Modbus map after you add each new point.

---

These methods correspond to the options on the Edit shortcut menu, which are also available through the Edit menu on the Modbus Editor menu bar.

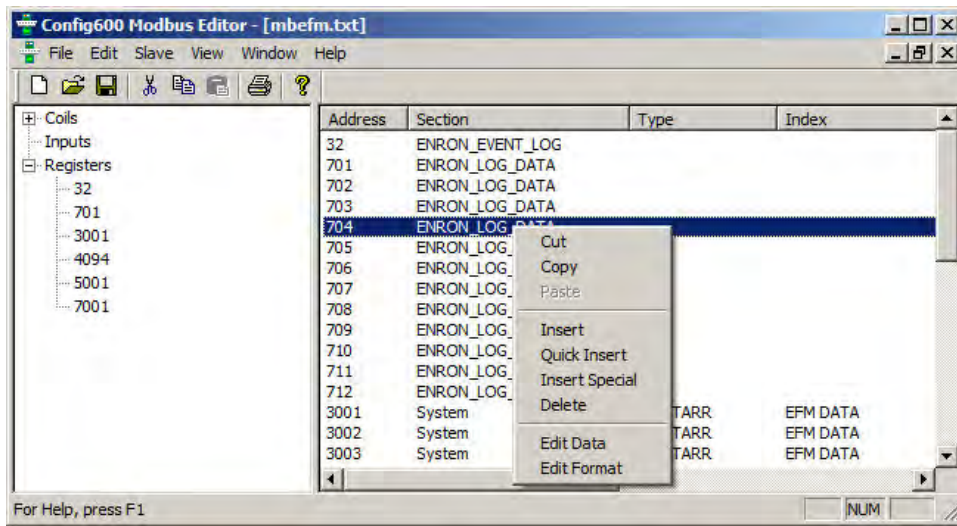

Figure 14-3. Insert shortcut menu

### 14.4.2 Quick Insert

To base a new data point on a selected data point:

1. Select the **data type** in the hierarchy menu. The associated list displays in the right pane.
2. Select a **data point** in the right pane. Right-click the data point to display the shortcut menu
3. Select **Quick Insert**. Using the next available starting address, the Modbus Editor adds the new data point to the data point listing.

---

**Note:** To further define this data point, refer to the procedures described in *Section 14.4.6, Edit Modbus Format*.

---

### 14.4.3 Insert Special

To add a data point field to the report:

1. Select the **data type** in the hierarchy menu. The associated list displays in the right pane.
2. Select a **data point** in the right pane. Right-click the data point to display the shortcut menu.
3. Select **Insert Special**. The Modbus Editor displays the Enter Details dialog box.



Figure 14-4. Enter Details dialog box

4. Indicate a **starting address** for the new data point. As a default, the Modbus Editor uses the next available address based on the data point you selected in step 2.
5. Click **OK**. The Choose dialog box displays.

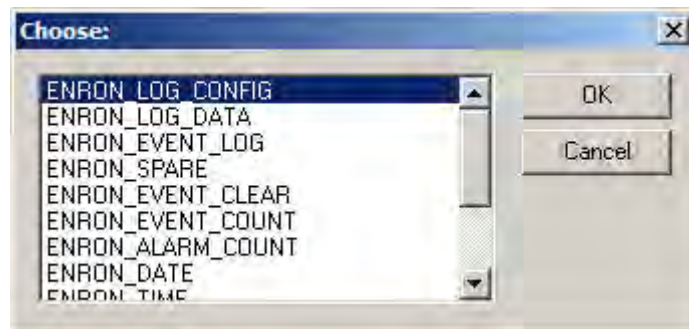

Figure 14-5. Choose dialog box

6. Select a **data item** type and click **OK**. The Modbus Editor adds the new data point to the data point listing.

---

**Note:** To further define this data point, refer to the procedures described in *Section 14.4.6, Edit Modbus Format*.

---

#### 14.4.4 Insert Special

To create the next available address using the same parameters as the selected data item:

1. Select the **data type** in the hierarchy menu. The associated list displays in the right pane.
2. Select a **data point** in the right pane. Right-click the data point to display the shortcut menu.
3. Select **Insert**. The Modbus Editor displays the Enter Details dialog box.



Figure 14-6. Enter Details dialog box

4. Indicate a **starting address** for the new data point. As a default, the Modbus Editor uses the next available address based on the data point you selected in step 2.
5. Click **OK**. The Connect Wizard displays.

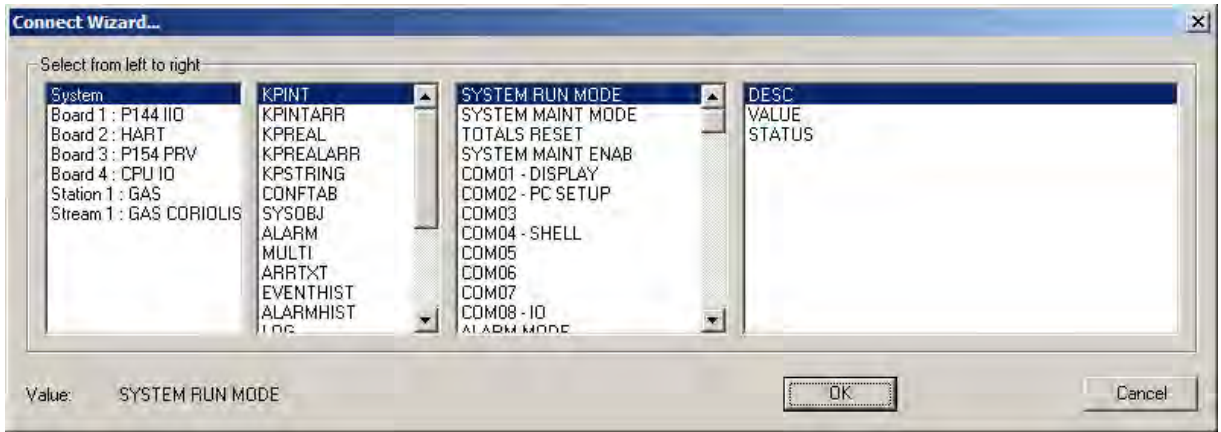

Figure 14-7. Connect Wizard

6. Define the new data point by highlighting values in each of the four columns (**source**, **type**, **item**, **field**). Select from left to right. Click ▼ or ▲ to display more values.
7. Click **OK**. The Modbus Editor displays, showing the newly added data point.

## 14.4.5 Delete a Data Point



### Caution

The Modbus Editor does not have an “undo” function. Once you delete a data point, you cannot restore it. You must re-create it.

To delete a data point:

1. **Right-click** a data point. A shortcut menu displays.
2. Select **Delete** from the shortcut menu. The Modbus Editor screen displays without the selected data point.

## 14.4.6 Edit Modbus Format

To edit the format of a Modbus register:

1. Select a **register** from the hierarchy menu. Config600 highlights the register in the left-hand pane.
2. Right-click a **data item**. Config600 displays a shortcut menu.

---

**Note:** The options on the shortcut menu are also available on the Edit menu on the Modbus Editor’s menu bar.

---

3. Select **Edit Format** from the shortcut menu. The Edit Format dialog box displays.

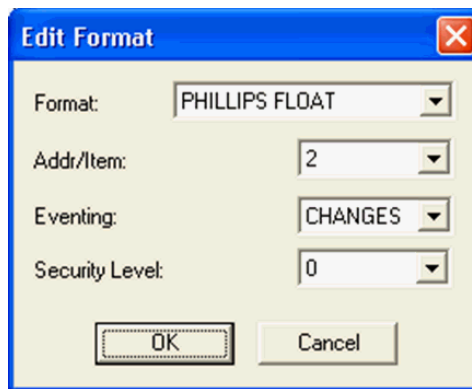

Figure 14-8. Edit Format dialog box

4. Select an address format. Click ▼ to display additional formats.

Field	Description
<b>Scale n nnnn</b>	Reads holding registers as integers, scaled between the values n and nnnn. In master mode, the S600+ displays the value returned in terms of the selected scaling. For example, 500 would represent 50% on the scaling 0 999 or 5% on the scaling 0 9999. You can configure data at every address (such as 0 to 65535).
<b>Float</b>	Reads holding registers as IEEE-format single-precision floating point numbers, Most Significant Byte (MSB) first. For each point required, one address is requested in the Modbus message and 4 bytes are returned. You can configure data at every address (such as 0 to 65535).
<b>Double</b>	Reads holding registers as IEEE-format double-precision floating point numbers. For each point required, one address is requested in the Modbus message and 8 bytes are returned. You can configure data at every address (such as 0 to 65535).
<b>Enron 16 Bit</b>	Reads holding registers as signed integers, in the range -32767 (Hex 8001) to 32767 (Hex 7FFF). You can configure data at every address (such as 0 to 65535).
<b>Enron 32 Bit</b>	Reads holding registers as unsigned long integers. Negative numbers are not allowed. You can configure data at every address (such as 0 to 65535).
<b>Enron Float</b>	Reads holding registers as IEEE-format single-precision floating point numbers, MSB first. For each point required, one address is requested in the Modbus message and 4 bytes are returned. You can configure data at every address (such as 0 to 65535).
<b>Rosemount</b>	Reads holding registers as IEEE-format single-precision floating point numbers, Least Significant Byte (LSB) first used on Rosemount DCS systems. For each point required, two addresses are requested in the Modbus message and 4 bytes are returned. You can configure data at every other address (such as 0, 2, 4 to 65534).
<b>Phillips Float</b>	Reads holding registers as IEEE-format single-precision numbers, MSB first. For each point required, two addresses are requested in the Modbus message and 4 bytes are returned. You can configure data at alternate addresses (such as 0, 2, 4 to 65534).

Field	Description
<b>Phillips Double</b>	Reads holding registers as IEEE-format double-precision numbers, MSB first. For each point required, four addresses are requested in the Modbus message and 8 bytes are returned. You can configure data at every fourth address (such as 0, 2, 4 to 65534).
<b>RFT 64 Bit</b>	Reads totals from a Micro Motion RFT transmitter using a proprietary data format.
<b>MVD Total</b>	Reads totals from a Micro Motion MVD transmitter using a proprietary data format.

- Complete the **Addr/Item** field to indicate the number of addresses Config600 must poll for each variable.
- Select the **Eventing** type if required. Click ▼ to display additional options.

Field	Description
<b>Disabled</b>	The eventing for this data point is disabled (default).
<b>Changes</b>	When the value written to the data point is different to the current value an event is logged.
<b>All</b>	Every time a write to the data point is performed an event is logged.

- If necessary, select the **Security Level**. Click ▼ to display additional options.

Option	Description
<b>0</b>	Maximum possible security level. Marks the Modbus address as read-only.
<b>9</b>	Minimum possible security level. Marks the Modbus address as read/write.

- Click **OK** to apply the edits. Config600 displays the Modbus Editor.

### 14.4.7 Insert a Message

Use this option to insert a message request into a Master Modbus map file. This message requests defined slave devices or all slaves for specific information.

---

**Note:** Slave Modbus map files do not allow the message option.

---

To insert a new message:

- Select **Slave > Add New Message** from the Modbus Editor menu bar. The Message Details dialog box displays.

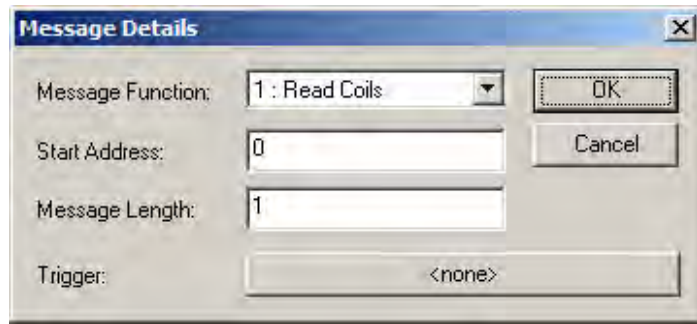

Figure 14-9. Message Details dialog box

2. Select a **Message Function**. Click ▼ to display additional options.
3. Define a **Start Address** and a **Message Length** in the dialog box.
4. Click the **Trigger** button to define a trigger value for the message. The Connect Wizard displays.

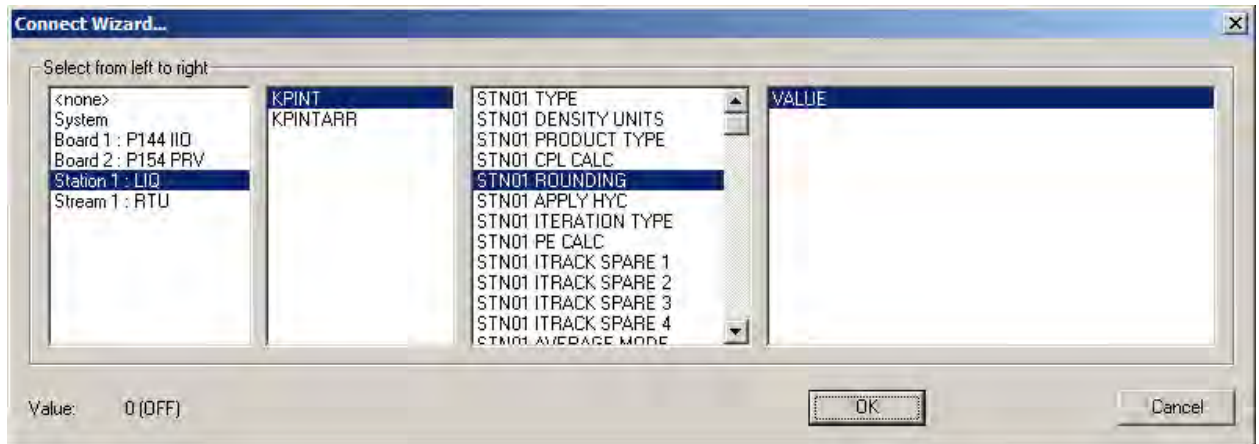

Figure 14-10. Connect Wizard

---

**Note:** Select a KPINT or KPINTARR value from the Connect Wizard if the message uses an object as a trigger mechanism. When the object value is set to 1, the system polls the message and, once the polls complete, sets the object’s value back to zero.

---

5. Highlight values in each of the four columns (**source, type, item, field**). Select from left to right. Click ▼ or ▲ to display more values.
6. Click **OK** to apply this definition. The Message Details dialog box displays showing the Trigger event you selected.

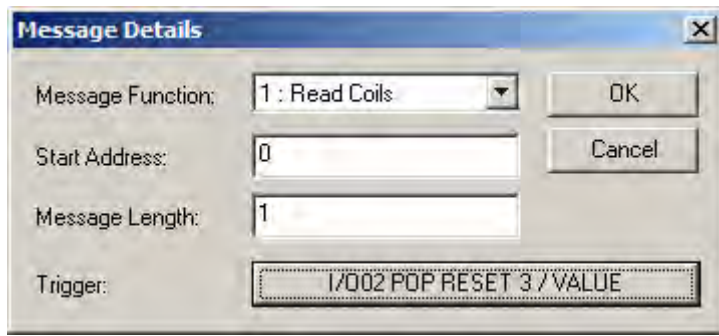

Figure 14-11. Message Details dialog box (with trigger)

7. Click **OK** to apply this message. Config600 displays a Select Slaves dialog box.

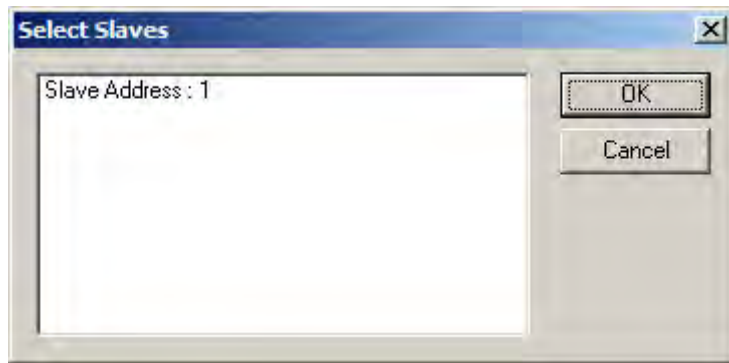

Figure 14-12. Select Slaves dialog box

8. Select a displayed **Slave Address** and click **OK** to apply the selection. Config600 displays the Modbus Editor.

### 14.4.8 Insert a Slave

You can add slaves into a Master Modbus map file at any time. When initially added, the new slave address has blank tables. You can either complete these blank tables one data point at a time or cut-and-paste data points from another slave.

To create a new slave:

1. Click in the **hierarchy menu** in the left pane.
2. Select **Slave > Add New Slave** from the menu bar. A Choose dialog box displays.





Figure 14-13. Choose dialog box

3. Select the **Slave Address** from the list of available addresses on the left-hand side of the screen.
4. Click **OK**. The Modbus Editor screen redisplay, showing your new slave in the hierarchy menu.

---

**Note:** You can also request a new start address at this time.

---

## 14.5 Regenerating Maps

Using an option in PCSetup, you can restore Modbus maps to the default values defined in the selected configuration.



**Caution**

**This option overwrites any edits or customisations you may have made to the maps in the selected configuration.**

1. Select **File > Regenerate** from the PCSetup menu bar. The Display and Modbus Regeneration dialog box displays.

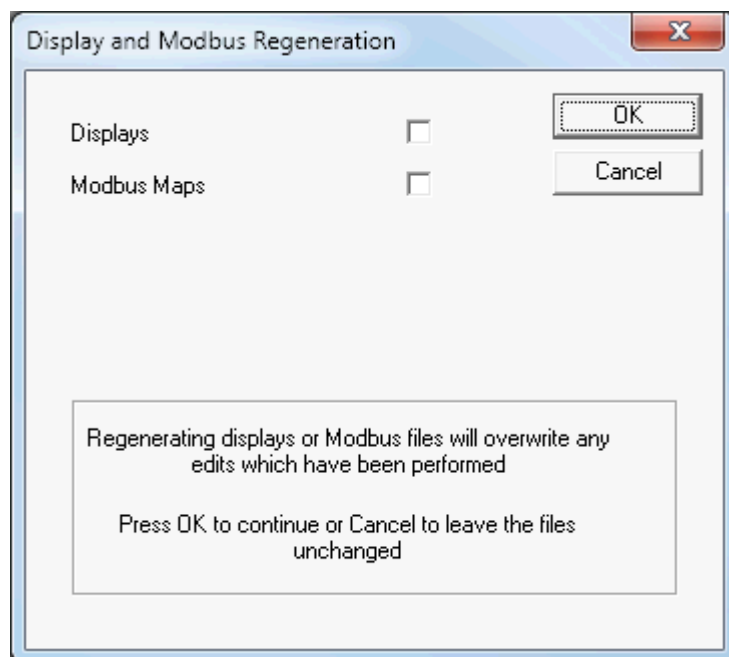
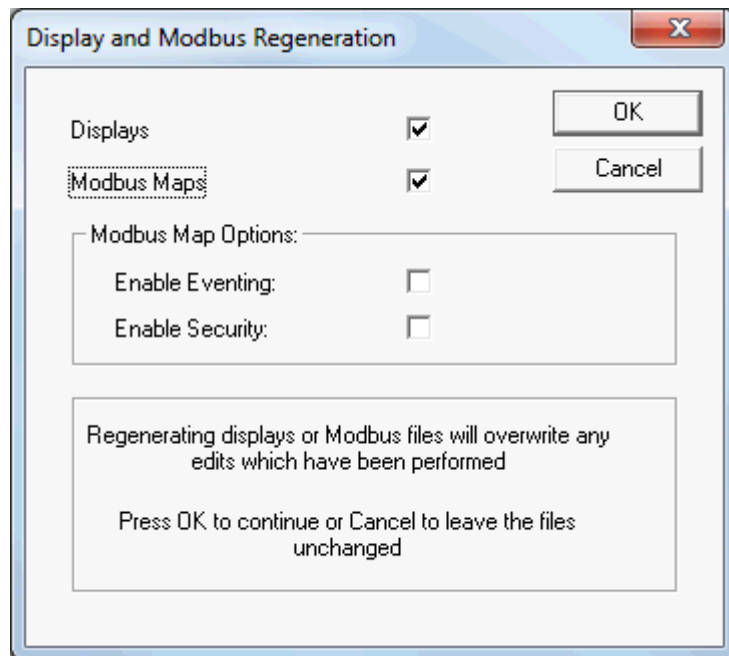

Figure 14-14. Modbus Map Regeneration

2. Select the **Modbus Maps** check box. The Modbus Map Options panel displays, showing the default Modbus options:



*Figure 14-15. Modbus Map Options*

3. Select the options you want to enable and click **OK**. Config600 restores all Modbus maps to the default values defined in the selected configuration.

## Chapter 15 – LogiCalc Editor

### In This Chapter

15.1	Accessing the LogiCalc Editor.....	15-2
15.1.1	LogiCalc Tips.....	15-4
15.1.2	Starting a LogiCalc.....	15-5
15.2	Creating a LogiCalc.....	15-5
15.2.1	Variables.....	15-6
15.2.2	LogiCalc Loops.....	15-7
15.2.3	LogiCalc Constants.....	15-8
15.2.4	Connecting to Data Items.....	15-9
15.2.5	If/Then/Endif.....	15-11
15.2.6	Special Functions.....	15-12
15.2.7	Saving and Compiling a LogiCalc.....	15-13
15.2.8	Running a LogiCalc in Simulation Mode.....	15-14
15.3	Installing a LogiCalc on the S600+.....	15-15
15.3.1	Remotely Debugging a LogiCalc.....	15-16
15.4	LogiCalc Examples.....	15-16
15.4.1	Perform PTZ Calculations.....	15-17
15.4.2	Convert Temperature Units.....	15-18
15.4.3	Convert Density Units to Kgm3.....	15-18
15.4.4	Convert Density Units from Kgm3.....	15-19
15.4.5	Perform PTZ Calculations and Convert Units.....	15-20
15.4.6	Perform PTZ Calculations on All Streams.....	15-22
15.5	LogiCalc Language Specifications.....	15-23
15.5.1	LogiCalc Statements.....	15-23
15.5.2	Built-In Functions.....	15-26
15.5.3	Alarms.....	15-28

---

**Note:** This editor is available **only** with the Config600 Pro software.

---



The S600+ can run LogiCalc programs written in LogiCalc, a Basic-like language proprietary to Emerson Process Management. You can add LogiCalc programs to an existing S600+ configuration without rebuilding the base software. This allows you to customise and extend the functionality of the S600+. LogiCalc programs can read, write, and perform calculations on values in the S600+ database.



### Caution

**This chapter is intended for use in conjunction with materials from the RA901 Advanced Config600 training course. That training is critical to understanding the concepts in this section. Unless you have completed that training, do not attempt to use the material in this section as a sole means of learning about the LogiCalc Editor.**

---

The LogiCalc Editor enables you to write, test, and debug programs. You can test LogiCalc programs on the PC against an actual S600+ config file or test them in-place, running on the S600+. You can also monitor LogiCalc programs running in the S600+ from the Webserver under Diags > LogiCalc.

**Notes:**

- In-place testing with Version 1.2 or earlier of Config600 requires a serial connection between your PC and the S600+. Version 1.3 or higher allows an Ethernet connection.
- The S600+ can execute several LogiCalcs in parallel, they run at a low task priority so in a large configuration they may run slowly. Hence they are not suitable for use where timing is critical.

**Example LogiCalcs**

The Config600 3.3 directory contains a LCLIB folder. In this folder are sample LogiCalc programs, provided solely as models to help you create your own LogiCalc programs. No warranty, expressed or implied, accompanies these programs. Additionally, no support is available for these programs.

---

## 15.1 Accessing the LogiCalc Editor

---

To access the LogiCalc Editor:

1. Select **Start > All Programs > Config600 3.3 > LogiCalc Editor**. The Config600 LogiCalc screen displays.

**Note:** If you have more than one version of Config600 on your machine, select the version appropriate to the configuration file.

---

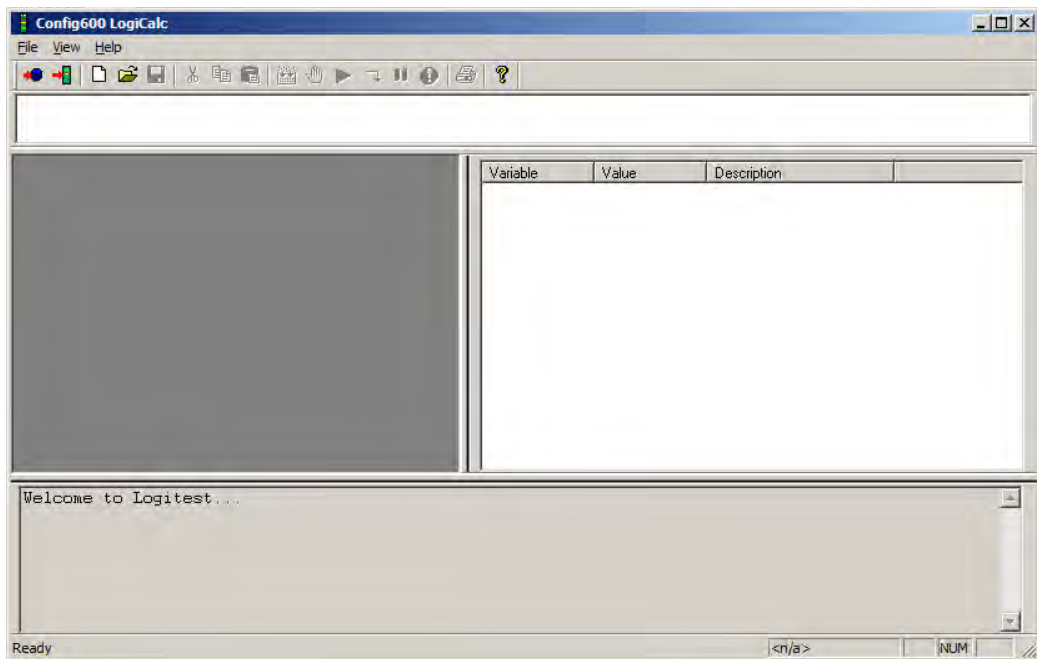

*Figure 15-1. LogiCalc screen*

2. Click the **Load Config** icon  located in the upper left-hand corner of the toolbar. The Select Config dialog displays.

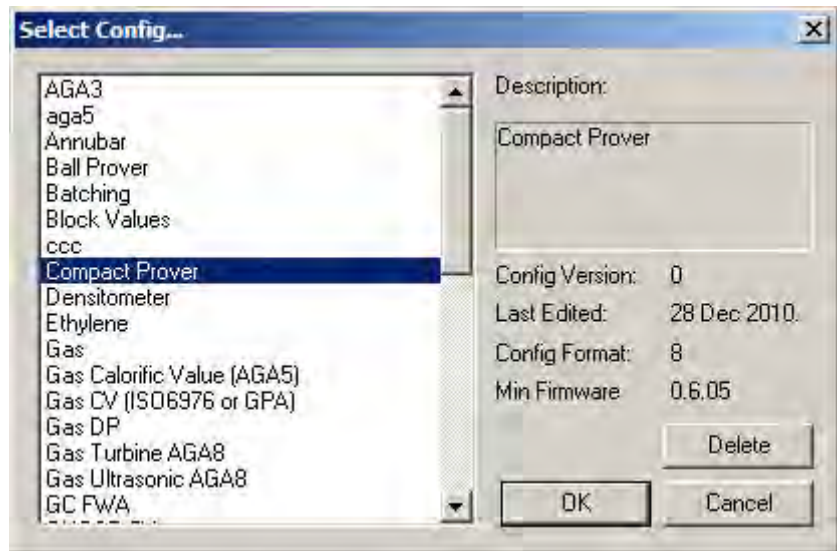

Figure 15-2. Select Config dialog box

**Note:** You can also display this dialog by selecting **File > Load Local Config** from the LogiCalc screen’s menu bar.

3. Select a configuration file and click **OK**. The LogiCalc screen redisplay, loaded with the LogiCalc in the selected configuration.

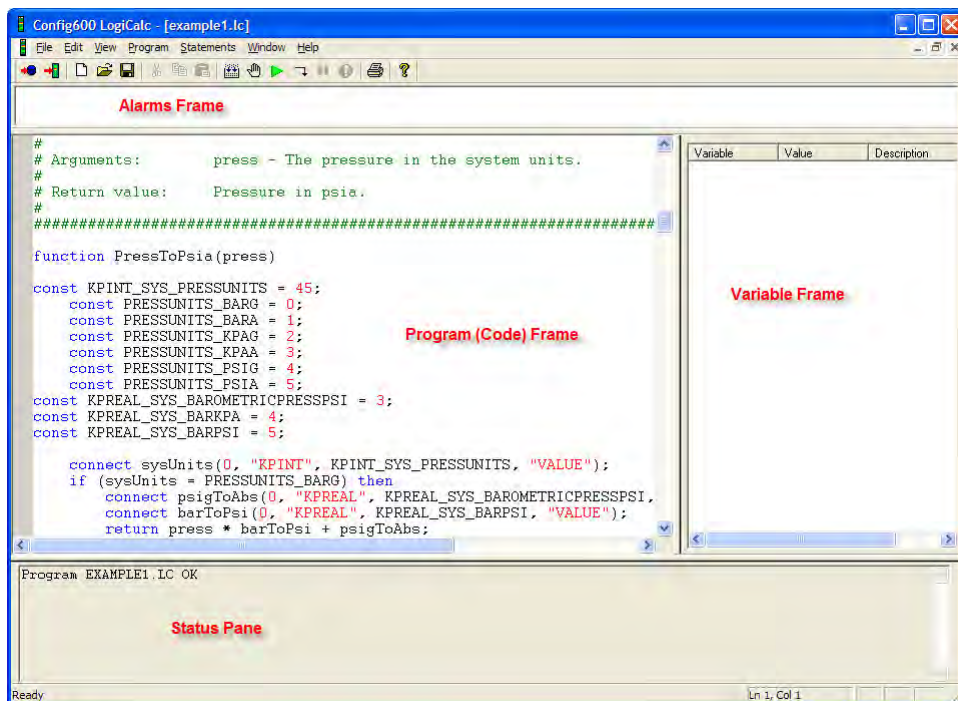

Figure 15-3. LogiCalc screen (loaded)

The LogiCalc Editor screen consists of four panes: Alarm, Program (or Code), Variable, and Status. You can dock, hide, or move each pane to suit your needs.

The LogiCalc Editor is designed for ease of use. The Program pane prompts you for the next step in writing the program by intelligently moving the cursor to the next task, either a necessary statement or portion of a statement. You can place statements in the program by

typing them in, by using keyboard shortcuts, or through the Statements menu. The LogiCalc Editor also uses the Connect Wizard to permit you easy access to items in the database.

For quick reference, the Editor always displays the cursor's position at the bottom of the window, below the Status pane, such as "Ln 2, Col 17" = line 2, column 17.

The Editor provides a "Goto Line" facility. It helps you navigate in longer LogiCalcs, enabling you to move the cursor to a specific line in the file. To access this facility, select **Edit > Goto Line** from the menu bar at the top of the screen.

The Alarms pane is useful when setting, accepting, and clearing alarms using the LogiCalc Editor. During debugging of the program, the test appears in the Alarms pane.

### 15.1.1 LogiCalc Tips

Review the following tips before you begin work on a LogiCalc program.

- Structurally, a LogiCalc is a list of one or more functions laid out sequentially in a text file. Functions start with the "function" keyword and end with the "end" keyword. Place the actual code to be executed (in statements) between these two keywords.
- End all functions and statements with a semicolon (;).
- Indent code within functions to improve readability.
- Some programming languages require you to specify what type of data (such as textual or numeric) a variable holds. LogiCalc automatically converts between the various data types, depending on the context.
- LogiCalc evaluates mathematical expressions using precedence rules and not from left to right. Use brackets and parentheses as a guide accordingly.
- The LogiCalc Editor supports both Undo (**Edit > Undo Typing** or **Ctrl + Z**) and Redo (**Edit > Redo Typing** or **Ctrl + Y**) functions.
- Limit the length of LogiCalc filenames to eight characters. The file extension is ".lc".
- LogiCalc always starts to execute a LogiCalc at the beginning of the last function in the file.
- Type constant names in uppercase letters with underscores. Variable names should not be all uppercase.
- The LogiCalc Editor colour-codes statements in blue and comments in green to differentiate them from the code.
- Use the "#" character at the start of a line to identify comments (short lines of explanatory text) you add to the code for documentation. You can place comments on their own line or on the end of a line.

## 15.1.2 Starting a LogiCalc

Writing LogiCalcs generally requires an existing S600+ configuration. If you do not have on your PC a copy of the configuration file with which the LogiCalc will eventually run, you can generate a file using the PCSetup Editor.

**Note:** If you generate a fresh configuration, make sure that it matches the destination configuration in all pertinent settings. Pay specific attention to database connections.

To start a LogiCalc, either create a new empty LogiCalc by clicking the New icon on the toolbar (  ) or modify an existing LogiCalc using the **File > Import** option.

When you create a new LogiCalc, the LogiCalc Editor displays a new window:

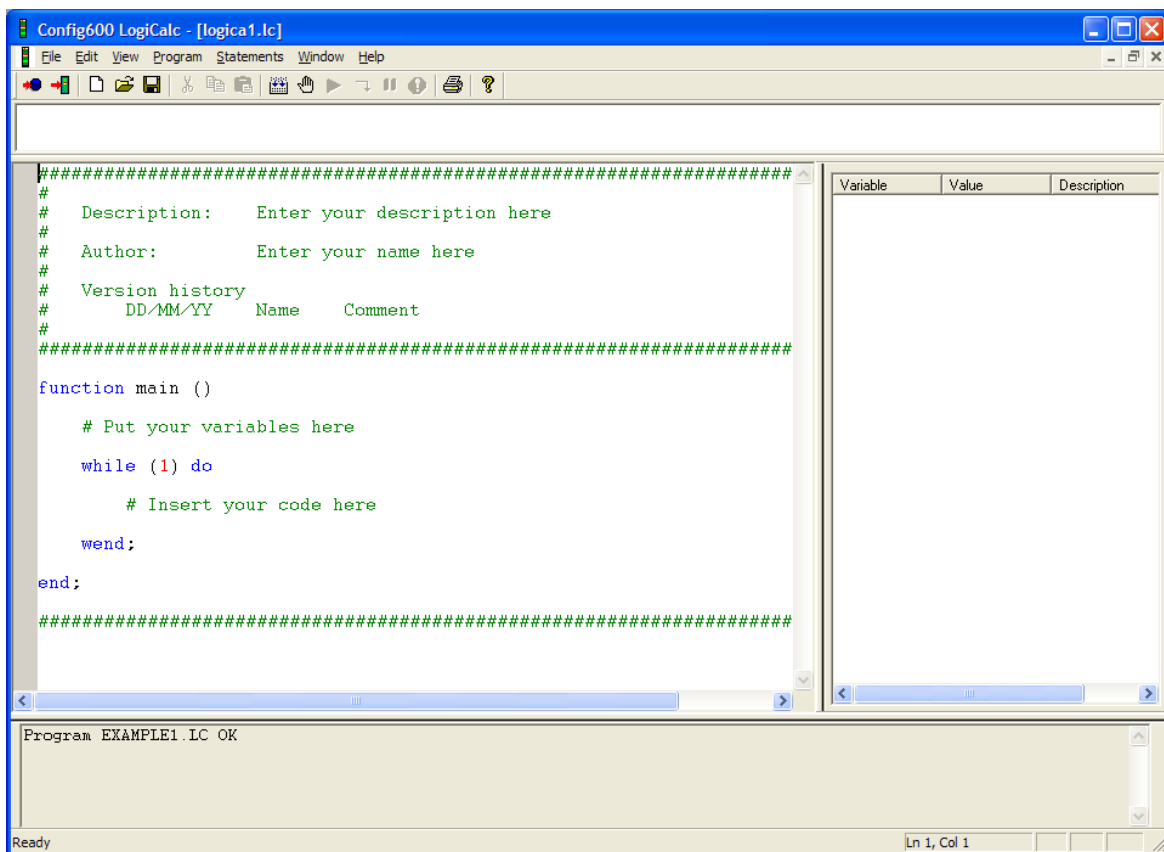

Figure 15-4. LogiCalc screen (loaded)

## 15.2 Creating a LogiCalc

The following example demonstrates how to build a simple LogiCalc function.

Once you start LogiCalc, the LogiCalc Editor positions the cursor where you should type the Function name. If you type *test*, the LogiCalc looks like this.

```
function test()  
  
end;
```

---

**Note:** All code examples in this chapter use this font convention to distinguish them from the text.

---

Next, you add some instructions to be executed. If you move the cursor down from the function tag to the next blank line, you see that the LogiCalc Editor has also inserted a tab on the next blank line. This provides indentation to help in readability.

## 15.2.1 Variables

Variables are boxes that hold data, which can be a number (such as 4) or a text string (such as “Hello”). You create variables with names and refer to them by these names in the LogiCalc code. To create a variable with a name “my\_value”, add the following line after the tab:

```
dim my_value;
```

The Dimension (dim) statement is used heavily in Basic-type languages for creating variables. You may have noticed that the LogiCalc Editor has recognised the dim statement and coloured it blue.

This new variable does not yet have a value. LogiCalc does not require you to specify what type of data (text or numeric) a variable holds. For this example, the variable should hold a number 1. You initialise the variable on the next line by changing the code to:

```
dim my_value;  
my_value = 1;
```

LogiCalc allows you to save space and increase readability by creating and initialising the variable in one step, so change the existing statement to:

```
dim my_value = 1;
```

Add the following statement on the next line:

```
my_value = my_value + 2 * 3;
```

This statement sets the value of my\_value to the result of the expression on the right of the = sign. LogiCalc evaluates expressions using precedence rules, so it evaluates the \* (multiply) **before** the +, giving the answer of  $1 + 6 = 7$ . That is different from a left-to-right evaluation of our expression, which would be  $3 * 3 = 9$ .

Use brackets to force a left-to-right evaluation of the expression:

```
my_value = (my_value + 2) * 3;
```

The program is now complete and should look like this:

```
function test()  
    dim my_value = 1;  
    my_value = (my_value + 2) * 3;  
end;
```



## 15.2.2 LogiCalc Loops

The example in the previous section executes a couple of statements and then stops. To create a LogiCalc that runs continuously, you need a loop.

**while/do/wend** To insert a while/do/wend loop, position the cursor at the beginning of the line “my\_value = (my\_value + 2) \* 3;”.

Insert a while/do/wend statement from the **Statements > while/do/wend** menu option or **Ctrl + W**. The LogiCalc Editor inserts a while/do/wend statement and positions the cursor in the brackets where you need to enter an expression.

Enter “my\_value < 100” as the expression and use **Edit > Cut** and **Edit > Paste** to rearrange the “my\_value = (my\_value + 2) \* 3;” line into the while loop.

The while/do/wend statement allows nesting like the function/end statement, so the semicolon comes **after** the wend.

The format of the statement is “while <expression> do <nested statements> wend;”

When executing, the expression is first evaluated and, if it is true, the nested statements within the while are then executed. Once this is done, execution goes back to the top to evaluate the expression again and this continues until the expression is false.

In our case, the expression is true initially and remains true a couple of times through the loop, my\_value growing each time the loop is executed. Eventually, my\_value stops being less than 100 (that is, it becomes greater than or equal to 100) and execution “breaks out” of the loop and continues down the LogiCalc.

The program is now complete and should look like this:

```
function test()
    dim my_value = 1;

    while (my_value < 100) do
        my_value = (my_value + 2) * 3;
    wend;
end;
```

**for/next** To insert a for/next loop that will run for a number of times specified explicitly, position the cursor at the beginning of the “my\_value = (my\_value + 2) \* 3;”. Insert a for/next statement by using the **Statement > for/next** menu or **Ctrl + R**.

To perform our calculation 10 times, enter the following:

```
function test()
    dim my_value = 1;
    dim stream_number;

    for stream_number = 1 to 10
        my_value = (my_value + 2) * 3;
    next;
end;
```

This loop requires another variable called `stream_number`. It has no assigned value in the `dim` statement, as the `for/next` statement has control over its value and it would overwrite any initialised value.

The `for/next` statement sets the `stream_number` variable to 1. Then the statement tests the value against 10. If the value is greater than 10 execution breaks out of the loop and continues on down the LogiCalc. If the value is not greater than 10, the nested statements within the loop execute. Once the execution completes, it goes back to the top of the loop, adds 1 to the loop variable (in this case, `stream_number`), and repeats the test against 10.

**Summary** The `while/do/wend` is functionally identical to the `for/next` statement. But it exists as a separate statement because `for/next` looping is more precise, compact, and readable than the `while/do/wend`.

The following example is a `for/next` loop repeated with a `while/do/wend` loop around it. The `while/do/wend` statement evaluates 1 as an expression, which is always **true**. LogiCalc actually understands true and false as non-zero and zero respectively, so the while loop never terminates and the code performs the same task forever. This loop is useful if some of your variables are real world values, like Analog Input readings.

```
function test()  
  while (1) do  
    dim my_value = 1;  
    dim stream_number;  
  
    for stream_number = 1 to 10  
      my_value = (my_value + 2) * 3;  
    next;  
  wend;  
end;
```

### 15.2.3 LogiCalc Constants

LogiCalc has the ability to create and define variables that are not allowed to change. For instance, the statement:

```
for stream_number = 1 to 10
```

Uses two numbers, but the variable name indicates that they are being used as stream numbers and that 1 means stream 1 and 10 means stream 10.

However, a statement may not fully show what is being done, such as:

```
pressure_mode = 1;
```

Obviously a mode for pressure is being set up, but what is type 1? A constant (`const`) statement can make this sort of code more readable by specifying somewhere in the LogiCalc:

```
const ADC_KEYPAD = 1;
```

This allows you to change the assignment to:

```
pressure_mode = ADC_KEYPAD;
```

which is much more specific.

The const statement is similar to the dim statement. However, you **must** assign a value in the const statement, whereas in a dim statement it is optional.

The following example shows the use of the const statement.

```
function test()
  const TRUE = 1;

  while (TRUE) do
    dim my_value = 1;
    dim stream_number;

    for stream_number = 1 to 10
      my_value = (my_value + 2) * 3;
    next;
  next;
end;
```

## 15.2.4 Connecting to Data Items

LogiCalc provides the connect statement so that data items from the S600+ database can be read and written from the program.

To simplify the process of building connect statements, the Editor uses a Connect Wizard that offers a point-and-click method of choosing data to use within LogiCalcs. To open the Connect Wizard, select **Statements > Connect** from the menu bar or press **Ctrl + T**.

---

**Note:** The Connect Wizard displays **only** if you have already loaded a configuration file. If the Connect Wizard does not display, save your LogiCalc **before** you attempt to load a configuration file.

---

The Connect (const) statement is similar to a dim statement, since it also creates a new variable. But instead of the new variable being empty and open to any value, the new variable is implicitly connected to a point in the S600+ database. For example, the Analog Input scanning task within the S600+ is continually updating a data point with new values read from the input. If a LogiCalc program reads that data point at any time, it should get the current value of meter pressure.

### Creating a Const Statement

To further explain this example, we can write a LogiCalc to read our stream 1 meter pressure into a variable and examine it. Position the cursor on the blank line in a new LogiCalc, and bring up the Connect Wizard by selecting **Statements > Connect** or **Ctrl + T**.

In the Connect Wizard, navigate to the Stream 1 meter pressure by selecting Stream 1 : **GAS DP, IOASSIGN, STR01 METER PRESSURE**, and **INUSE**. Once you find the desired data point, click **OK**.

The Connect Wizard adds two lines of code, and the Editor positions the cursor just after the connect statement so that you can complete the statement by typing a variable name. Type *pressure*.

The LogiCalc should now look like this:

```
function test()
const IOASSIGN_GASDP_METERPRESSURE = 0;
  connect pressure(stream(1), "IOASSIGN", IOASSIGN_GASDP_METERPRESSURE,
"INUSE");
end;
```

Const statements can define a number by use of the constant name. So the const statement above with a name defines 0 to mean “IOASSIGN\_GASDP\_METERPRESSURE”. The constant name may help you to recognize it later.

In the Connect statement, stream(1) refers to the database section that is reserved for stream 1.

The S600+ database is divided into sections, each section having within it a selection of the available data types. Within the sections, the database item locations are numbered:

- 0: System
- 1–7: I/O Modules 1 to 7
- 10–11: Stations 1 and 2
- 15–24: Streams 1 to 10.

---

**Note:** Database item locations 8, 9, and 12 through 14 are reserved for system use.

---

LogiCalc accesses the S600+ database by calling upon these numbers in parentheses after functions and statements. LogiCalc translates the section number by adding or subtracting out the number of sections before the pertinent one.

For example, a const statement calls stream(1). This is another built-in function, stream(x), which just adds 14 to the stream number so that it conforms to the above section table. LogiCalc could refer to it as 15 instead of stream(1) but, that would be less understandable to the user reading the code.

### Using a Const Statement

To further explain this example, you can write a LogiCalc to read the stream 1 meter pressure into a variable and examine it. Position the cursor on the blank line in a new LogiCalc, and bring up the Connect Wizard by selecting **Statements > Connect** or **Ctrl + T**.

To demonstrate performing calculations on a connected data item, multiply the meter pressure from the example above by 2 and store the value back in the database. To make sure the program knows where to store the value back, create a new data item using the System Editor. This example uses an unused data point in the database.

Position the cursor on the next line from the connect statement and summon the Connect Wizard. Select **System, KPREAL, Spare, and Value**. Type “spare” as the Constant name.

This operation loops again and again, so the value tracks the pressure in real time. Note how the while/do/wend loop is only around the calculation. If it were around the whole program, the code would be reconnecting pressure and spare every time, which would increase the amount of time necessary to track changes in pressure.

Modify the LogiCalc as follows:

```
function test()
const IOASSIGN_GASDP_METERPRESSURE = 0;
const KPREAL_SYS_SPARE = 13;
  connect pressure(stream(1), "IOASSIGN", IOASSIGN_GASDP_METERPRESSURE, "INUSE");
  connect spare(0, "KPREAL", KPREAL_SYS_SPARE, "INUSE");

  while (1) do
    spare = pressure * 2;
  wend;
end;
```

## 15.2.5 If/Then/Endif

The if/then/endif and the if/then/else/endif statements allow LogiCalc to make decisions.

A LogiCalc can make a decision based on some external conditions. For example, if the meter pressure is in keypad (R/W) mode, it should be multiplied by 3 instead of 2.

First, connect to the mode of the meter pressure. Open the Connect Wizard and select Board 1: **P144I/O, ADC, I/O ADC 01**, and **MODE**. Select the Define Options checkbox, which creates const statements for all the different options of the parameter. In this case, all the modes area assigned a const statement with an integer value.

Type the variable name as *pressure\_mode* and change the const names for the modes (that is, from IO1ADC01\_MEASURED to ADC\_MEASURED, and such.).

Add the if/then statements. The full format for this statement is if <expression> then <nested statements> else <nested statements> endif; and execution is directed either to the first set of statements or the second, depending on the outcome of the expression evaluation.

The if <expression> then <nested statements> endif; variant only has the one set of nested statements and executes them only if the expression is true. Otherwise they are skipped.

The new LogiCalc continually evaluates the *pressure\_mode* and, if it is in keypad executes the \* 3 statement. Otherwise, it executes the \* 2 statement.

The complete LogiCalc looks like this:

```
function test()
const IOASSIGN_GASDP_METERPRESSURE = 0;
const KPREAL_SYS_SPARE = 13;
const ADC_P144IIO_IO01ADC01 = 0;
  const ADC_MEASURED = 0;
  const ADC_KEYPAD = 1;
  const ADC_AVERAGE = 2;
  const ADC_LASTGOOD = 3;
  const ADC_KEYPADF = 4;
  const ADC_AVERAGEF = 5;
  const ADC_LASTGOODF = 6;

  connect pressure(stream(1), "IOASSIGN", IOASSIGN_GASDP_METERPRESSURE,
    "INUSE");
  connect spare(0, "KPREAL", KPREAL_SYS_SPARE, "INUSE");
```

```
connect pressure_mode(ioboard(1), "ADC", ADC_P144IIO_IO01ADC01, "MODE");

while (1) do
  if (pressure_mode = ADC_KEYPAD) then
    spare = pressure * 3;
  else
    spare = pressure * 2;
  endif;
wend;
end;
```

## 15.2.6 Special Functions

LogiCalc can use data from the S600+ which is not an item in the database. It can read configuration-specific details, such as the number of streams present and what type they are. Use the numstream() function to determine the number of streams. Two other functions—numstations() and numiobards()—perform the same functions for stations and I/O boards.

For example, the following simple LogiCalc reads the stream 1 meter pressure and copies it to a hard coded keypad real object.

```
function test()
const IOASSIGN_GASDP_METERPRESSURE = 0;
const KPREAL_SYS_SPARE = 13;

connect pressure(stream(1), "IOASSIGN", IOASSIGN_GASDP_METERPRESSURE, "INUSE");
connect spare(0, "KPREAL", KPREAL_SYS_SPARE, "INUSE");

while (1) do
  spare = pressure * 2;
wend;
end;
```

To expand it to sum the results of all stream pressures into this keypad real, use the numstreams() function. This is a built-in function that returns the number of streams in a configuration. Then, use a for/next statement to span the streams.

```
function test()
const IOASSIGN_GASDP_METERPRESSURE = 0;
const KPREAL_SYS_SPARE = 13;

connect spare(0, "KPREAL", KPREAL_SYS_SPARE, "INUSE");

while (1) do
  dim stream_number;      # Hold the current stream number

  spare = 0;
  for stream_number = 1 to numstreams()
    connect pressure(stream(stream_number), "IOASSIGN",
IOASSIGN_GASDP_METERPRESSURE, "INUSE");
    spare = spare + pressure * 2;
  next;
wend;
end;
```

Note the added variable, stream\_number (which is used as the variable in the for/next loop), and the comment.

The spare variable is cleared down and the for/next loop sets stream\_number to each stream present before executing the summing code. This code connects to the stream pressure for the current stream.

---

**Note:** Stream (stream\_number) in the connect pressure statement determines the stream to which the pressure variable is connected. Once pressure is connected to the correct stream, the LogiCalc reads it, multiplies it by 2 and adds it into the spare variable.

---

You can modify this example. The spare variable is a direct link to the data item in the S600+ database, so it would be constantly changing back to zero and summing. It could be modified to sum it in another variable and then set this variable when the final sum is reached.

The stream\_number variable is created inside the while/do/wend loop which means it is created every time around. This is not necessary and needs only to be created once. To make the program more efficient, move this statement out of the loop.

The modified LogiCalc now looks like:

```
function test()
const IOASSIGN_GASDP_METERPRESSURE = 0;
const KPREAL_SYS_SPARE = 13;

connect spare(0, "KPREAL", KPREAL_SYS_SPARE, "INUSE");
dim stream_number;      # Hold the current stream number

while (1) do
    dim sum = 0;        # Hold the sum of two times the meter pressures

    for stream_number = 1 to numstreams()
        connect pressure(stream(stream_number), "IOASSIGN",
IOASSIGN_GASDP_METERPRESSURE, "INUSE");
        sum = sum + pressure * 2;
    next;

    spare = sum;
wend;
end;
```

## 15.2.7 Saving and Compiling a LogiCalc

Before you compile the program, first save it to the configuration directory. Until you save the program to the configuration directory, the program is only saved in the PC's memory.

To save, click **Save** () on the toolbar and type a name for your new LogiCalc. **Logica1** is the default program name. The file extension is ".lc".

---

**Note:** Limit all LogiCalc filenames to eight or fewer characters, all in lower case letters, such as *myapplic.lc*. The S600+ operating system requires this.

---

The Save As dialog box opens the LogiCalc folder in the open configuration directory. If for any reason, the Save As command does

not open in the LogiCalc folder, navigate to the appropriate configuration folder and find a LogiCalc sub-folder.

Compilation allows the LogiCalc Editor to check your code, ensure that it is valid, and to create some internal data structures that allow the code to run. If you make changes to a LogiCalc and run it without first compiling it, the last compiled version runs instead.

To compile your LogiCalc, click **Compile** () on the toolbar. After a short pause, the Status pane should show the message `Program LOGICAL OK.`

The compiler contains an error checking mechanism. When the LogiCalc Editor compiles a program with an error, it displays the location and type of error in the Status pane, as shown below:

```
Error: test.lc - Line 2 : Expecting variable, constant or bracket
    dim my_value = ;
                  ^
```

This message indicates an error on line number 2 of the program. Also, the Editor positions the cursor on the offending line at the position where the error was encountered to allow you to type a correction.

Once saved and successfully, compiled, the LogiCalc is ready to run.

## 15.2.8 Running a LogiCalc in Simulation Mode

The LogiCalc Editor allows you to run your LogiCalc in simulation mode before you actually download it to the S600+ to test it. The LogiCalc Editor can run LogiCalcs either at full speed or line-by-line (debug mode).

To halt execution at any time, click **Stop** (.

### Free Running

To run the program at full speed, compile it and click **Run** (). The program will finish with the message: `program TEST.LC has stopped.`

### Line by Line

To run the LogiCalc in single step mode, ensure the LogiCalc has compiled successfully and then click **Step** (.

The LogiCalc Editor first displays the message `Program TEST.LC has started.` Then it displays a yellow arrow in the Code pane, indicating the statement that is about to run. Finally, it also fills in the Variable pane with a list of all the variables currently active in the LogiCalc, together with their current values.

Click **Step** until the Editor has moved through through the entire LogiCalc. Click **Step** again and the program finishes, displaying the message: `Program TEST.LC has stopped.`

### Breakpoint

A breakpoint is a line marker which stops a free-running LogiCalc.

Once the Editor reaches the breakpoint, it continues to run using single-stepping. Breakpoints are useful when running a long LogiCalc.

To use a breakpoint, position the cursor anywhere on the desired breakpoint line, and click **Toggle Breakpoint** (). A red stop sign



 displays next to the statement, indicating that a breakpoint is active. Clicking Toggle Breakpoint again turns off the breakpoint.

Click **Run** () to permit the LogiCalc to free-run at full speed. After a short pause, the yellow arrow marker appears on top of the red breakpoint icon, indicating that the LogiCalc has executed all the statements before the breakpoint and has now stopped at the breakpoint. Also, the variable window will now update with current values.

Single-step the program through the remaining steps. The program finishes and displays the message: `program TEST.LC has stopped.`

### Changing Variables

While single-stepping through a LogiCalc, you can manually change a variable.

Double-click on the variable text in the Variable pane. The Editor displays the Set Variable dialog.

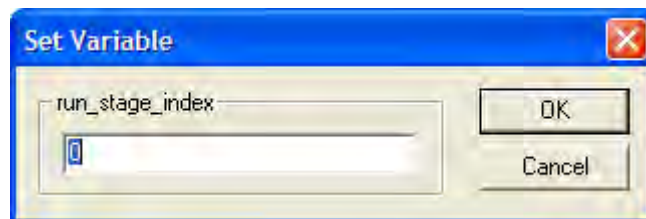

Figure 15-5. Set Variable dialog

Change the variable value, click **OK**, and then continue single-stepping through the LogiCalc.

The value updates, using the newly supplied value in the calculation statement.

---

**Note:** You can change values while the program is free running (not single stepping), but the Variables pane will not update until the program hits a breakpoint. This is **not** a recommended procedure as you do not know what your LogiCalc is doing when you set the value.

---

## 15.3 Installing a LogiCalc on the S600+

Once you have compiled and tested a LogiCalc, save it to the configuration directory.

To install the LogiCalc to a S600+, start the Config Transfer utility and transfer the configuration (including with any associated LogiCalcs files in the configuration) to the LogiCalc folder. For further information, refer to *Chapter 9, Config Transfer*.

### 15.3.1 Remotely Debugging a LogiCalc

You can test LogiCalc programs on-line in the S600+. To accomplish this in-place testing, you need either a serial connection between your PC and the S600+ (if you are using Config600 version 1.2 or earlier) or an Ethernet connection (if you are using a version higher than 1.2). You can also use shell commands to monitor LogiCalc programs running in the S600+.



Ensure that the connection between the S600+ and the PC is working. Also ensure that the PCSetup transfer program is not using the connection. Start the LogiCalc Editor and click **Connect to S600** (). Select the connection details and click **OK**.

After a few seconds, the following message displays in the Status pane:

```
Connecting to S600. Please wait...
Program TEST.LC OK
Done.
```

The running LogiCalc should also appear in the Code pane. If it does not appear, check the connection settings and try again.

To view the currently running LogiCalc without interrupting it, use the shell functions. To examine a free-running LogiCalc from the LogiCalc Editor, insert a breakpoint and stop the LogiCalc temporarily.

Place the cursor on the desired line and press **F9** or click **Toggle Breakpoint** (). The breakpoint marker () displays to the left of the line. Soon thereafter the program reaches the breakpoint and the yellow execution arrow appears on top of this red stop sign. Values of all the variables display in the variables pane.

To see the effect on the variables, step through the program line-by-line. The information you view is the real data from the S600+, sent through the serial or Ethernet link. It is not a LogiCalc Editor simulation.

If the value is in keypad mode, go to the front panel and change it. Do another single-step and see the values update to your newly entered keypad value.

To disconnect from the S600+, click **Connect** (). If the LogiCalc is sitting at a breakpoint, disconnecting restarts the LogiCalc free-running.

---

## 15.4 LogiCalc Examples

The following examples may be useful references in building LogiCalc programs for your application. Remember, LogiCalc considers any text following a # to be comments and ignores it.

---

**Note:** The folder **LCLIB** is included in the directory in which you installed the Config600 software. This LCLIB folder contains some sample LogiCalc programs. These are only examples for illustrative purposes. They are not provided with any express or implied guarantee or warranty. Additionally, Remote Automation Solutions does not provide support if you choose to use these example programs.

---

## 15.4.1 Perform PTZ Calculations

```
#####
# Perform PTZ for all gas dp & gas turbine streams in the system.      #
# Version History
#
# v0.6 - 17/10/2000 - GW - conversion routines fixed. There were several
# errors in the calculations. CalcPtz() function removed to avoid duplication of
# constants
#
# v0.5 - 26/06/2000 - GW - temp variable removed from main loop. Unnecessary
# when calling a function if a return value is not required.
#
# v0.4 - 23/12/1999 - GW - const 's' made dim as it hasn't been initialised by
# a constant expression as required by LogiCalc v0.20 and above. Support added
# for gas turbine.
#
# v0.3 - 26/11/1999 - GW - s in ptz() made const.
#
# v0.2 - 24/11/1999 - GW - Ported to v0.15 of LogiCalc. Units conversion added
# in. Some connects moved inside main loop for efficiency.
#
# v0.1 - 22/11/1999 - GW - 's' added as intermediate variable to shrink code
# down and make it run a bit faster.
#
#####
# Name:                PressToBarg
# function:             Convert pressure to barg from the system units.
# Arguments:           press - The pressure in the system units.
# return value:        Pressure in barg.
#####

function PressToBarg(press)

const KPINT_SYS_PRESSUNITS = 45;
const PRESSUNITS_BARG = 0;
const PRESSUNITS_BARA = 1;
const PRESSUNITS_KPAG = 2;
const PRESSUNITS_KPAA = 3;
const PRESSUNITS_PSIG = 4;
const PRESSUNITS_PSIA = 5;
const KPREAL_SYS_BARGBARA = 2;
const KPREAL_SYS_BARKPA = 4;
const KPREAL_SYS_BARPSI = 5;

connect sysUnits(0, "KPINT", KPINT_SYS_PRESSUNITS, "VALUE");
if (sysUnits = PRESSUNITS_BARG) then
    return press;
endif;

if (sysUnits = PRESSUNITS_BARA) then
    connect bargToAbs(0, "KPREAL", KPREAL_SYS_BARGBARA, "VALUE");
    return press - bargToAbs;
```

```

endif;

if (sysUnits = PRESSUNITS_KPAG) then
    connect bargToKpa(0, "KPREAL", KPREAL_SYS_BARKPA, "VALUE");
    return press / bargToKpa;
endif;

if (sysUnits = PRESSUNITS_KPAA) then
    connect bargToAbs(0, "KPREAL", KPREAL_SYS_BARGBARA, "VALUE");
    connect bargToKpa(0, "KPREAL", KPREAL_SYS_BARKPA, "VALUE");
    return press / bargToKpa - bargToAbs;
endif;

if (sysUnits = PRESSUNITS_PSIG) then
    connect bargToPsi(0, "KPREAL", KPREAL_SYS_BARPSI, "VALUE");
    return press / bargToPsi;
endif;

if (sysUnits = PRESSUNITS_PSIA) then
    connect bargToAbs(0, "KPREAL", KPREAL_SYS_BARGBARA, "VALUE");
    connect bargToPsi(0, "KPREAL", KPREAL_SYS_BARPSI, "VALUE");
    return press / bargToPsi - bargToAbs;
endif;
end;

```

## 15.4.2 Convert Temperature Units

```

#####
# Name:                TempToDegc
# function:            Convert temperature to degc from the system units.
# Arguments:          temp - The temperature in the system units.
# return value:       temperature in degc.
#####

```

```

function TempToDegc(temp)

const KPINT_SYS_TEMPUNITS = 47;
const TEMPUNITS_DEGC = 0;
const TEMPUNITS_DEGF = 1;
const TEMPUNITS_DEGK = 2;
const KPREAL_SYS_DEGCK = 7;

connect sysUnits(0, "KPINT", KPINT_SYS_TEMPUNITS, "VALUE");
if (sysUnits = TEMPUNITS_DEGC) then
    return temp;
endif;

if (sysUnits = TEMPUNITS_DEGF) then
    return (temp - 32.0) / 9.0 * 5.0;
endif;

if (sysUnits = TEMPUNITS_DEGK) then
    connect degcToDegk(0, "KPREAL", KPREAL_SYS_DEGCK, "VALUE");
    return temp - degcToDegk;
endif;
end;

```

## 15.4.3 Convert Density Units to Kgm3

```

#####
# Name:                DensToKgm3
# function:            Convert density to Kgm3 from the system units.
# Arguments:          dens - The density in the system units.
#####

```

```

# return value:          density in kgm3.
#####

function DensToKgm3(dens)

const KPINT_SYS_DENSUNITS = 48;
const DENSUNITS_KGM3 = 0;
const DENSUNITS_KGL = 1;
const DENSUNITS_LBSCF = 2;
const DENSUNITS_GMCC = 3;
const DENSUNITS_KGSM3 = 4;
const KPREAL_SYS_LBKG = 0;
const KPREAL_SYS_M3CF = 9;

connect sysUnits(0, "KPINT", KPINT_SYS_DENSUNITS, "VALUE");

if (sysUnits = DENSUNITS_KGM3) then
    return dens;
endif;

if (sysUnits = DENSUNITS_KGL) then
    return dens * 1000;
endif;

if (sysUnits = DENSUNITS_LBSCF) then
    connect lbToKg(0, "KPREAL", KPREAL_SYS_LBKG, "VALUE");
    connect m3ToCf(0, "KPREAL", KPREAL_SYS_M3CF, "VALUE");

    return dens * lbToKg * m3ToCf;
endif;

if (sysUnits = DENSUNITS_GMCC) then
    return dens * 1000;
endif;

if (sysUnits = DENSUNITS_KGSM3) then
    return dens;
endif;
end;

```

#### 15.4.4 Convert Density Units from Kgm3

```

#####
# Name:                  DensFromKgm3
# function:              Convert density from Kgm3 to the system units.
# Arguments:            dens - The density in kgm3.
# return value:         density in system units.
#####

function DensFromKgm3(dens)

const KPINT_SYS_DENSUNITS = 48;
const DENSUNITS_KGM3 = 0;
const DENSUNITS_KGL = 1;
const DENSUNITS_LBSCF = 2;
const DENSUNITS_GMCC = 3;
const DENSUNITS_KGSM3 = 4;
const KPREAL_SYS_LBKG = 0;
const KPREAL_SYS_M3CF = 9;

connect sysUnits(0, "KPINT", KPINT_SYS_DENSUNITS, "VALUE");

if (sysUnits = DENSUNITS_KGM3) then

```

```

    return dens;
endif;

if (sysUnits = DENSUNITS_KGL) then
    return dens / 1000;
endif;

if (sysUnits = DENSUNITS_LBSCF) then
    connect lbToKg(0, "KPREAL", KPREAL_SYS_LBKG, "VALUE");
    connect m3ToCf(0, "KPREAL", KPREAL_SYS_M3CF, "VALUE");

    return dens / (lbToKg * m3ToCf);
endif;

if (sysUnits = DENSUNITS_GMCC) then
    return dens / 1000;
endif;

if (sysUnits = DENSUNITS_KGSM3) then
    return dens;
endif;
end;
```

## 15.4.5 Perform PTZ Calculations and Convert Units

```

#####
# Name:                DoStreamPtz
# function:             Get the data from the database for the passed stream,
# calculate the PTZ and place the result back into the database. Do units
# conversion on all values.
# Arguments:           s - stream number
# return value:        1 if we did calc, 0 if we didn't
#####

function DoStreamPtz(s)
    const ATMOSPHERIC_PRESSURE = 1.01325;
    const ABSOLUTE_ZERO = 273.15;
const KPINT_STREAMTYPE = 0;
    const STREAMTYPE_GASDP = 0;
    const STREAMTYPE_GASTURB = 1;
    const STREAMTYPE_GASUS = 2;
    const STREAMTYPE_LIQTURB = 3;
    const STREAMTYPE_PRVBIDI = 4;
const KPREAL_GASDP_STDPRESS = 9;
const KPREAL_GASTURB_STDPRESS = 1;
const KPREAL_GASDP_STDTEMP = 8;
const CALCALMITEM_GASDP_UPSTRCOMPRESS = 16;
const CALCALMITEM_GASDP_STDDENS = 8;
const CALCALMITEM_GASDP_STDCOMPRESS = 17;
const CALCALMITEM_GASDP_UPSTRPRESS = 10;
const CALCALMITEM_GASDP_UPSTRTEMP = 7;
const CALCALMITEM_GASDP_UPSTRDENS = 4;
const CALCALMITEM_GASTURB_STRCOMPRESS = 10;
const IOASSIGN_GASTURB_STREAMTEMP = 5;
const CALCALMITEM_GASTURB_STDDENS = 5;
const CALCALMITEM_GASTURB_STDCOMPRESS = 11;
const KPREAL_GASTURB_STDTEMP = 0;
const IOASSIGN_GASTURB_METERPRESSURE = 0;
const CALCALMITEM_GASTURB_STREAMDENS = 4;

    connect strType(s, "KPINT", KPINT_STREAMTYPE, "VALUE");

    if (strType <> STREAMTYPE_GASDP) AND (strType <> STREAMTYPE_GASTURB) then
```

```

        return 0;
    endif;

# Define all the indexes for the various gas stream types
    dim stdPress;
    dim upstrCompress;
    dim upstrTemp;

# connect all the data
    if (strType = STREAMTYPE_GASDP) then
        connect dbStdPress(s, "KPREAL", KPREAL_GASDP_STDPRESS, "VALUE");
        stdPress = dbStdPress;
        connect dbUpstrCompress(s, "CALCALMITEM",
CALCALMITEM_GASDP_UPSTRCOMPRESS, "INUSE");
        upstrCompress = dbUpstrCompress;
        connect dbUpstrTemp(s, "CALCALMITEM", CALCALMITEM_GASDP_UPSTRTEMP,
            "INUSE");
        upstrTemp = dbUpstrTemp;
    endif;

    if (strType = STREAMTYPE_GASTURB) then
        connect dbStdPress(s, "KPREAL", KPREAL_GASTURB_STDPRESS, "VALUE");
        stdPress = dbStdPress;
        connect dbUpstrCompress(s, "CALCALMITEM",
CALCALMITEM_GASTURB_STRCOMPRESS, "INUSE");
        upstrCompress = dbUpstrCompress;
        connect dbUpstrTemp(s, "IOASSIGN", IOASSIGN_GASTURB_STREAMTEMP, "INUSE");
        upstrTemp = dbUpstrTemp;
    endif;

# Convert the data
    dim stdPressBarg;
    call stdPressBarg = PressToBarg(stdPress);

    dim upstrTempDegc;
    call upstrTempDegc = TempToDegc(upstrTemp);

    dim denom = (upstrTempDegc + ABSOLUTE_ZERO) * upstrCompress *
        (stdPressBarg + ATMOSPHERIC_PRESSURE);

    if (denom > 0.0) then
        dim stdDens;
        dim stdCompress;
        dim stdTemp;
        dim upstrPress;

# connect more data
        if (strType = STREAMTYPE_GASDP) then
            connect dbStdDens(s, "CALCALMITEM", CALCALMITEM_GASDP_STDDENS,
                "INUSE");
            stdDens = dbStdDens;
            connect dbStdCompress(s, "CALCALMITEM",
CALCALMITEM_GASDP_STDCOMPRESS, "INUSE");
            stdCompress = dbStdCompress;
            connect dbStdTemp(s, "KPREAL", KPREAL_GASDP_STDTEMP, "VALUE");
            stdTemp = dbStdTemp;
            connect dbUpstrPress(s, "CALCALMITEM", CALCALMITEM_GASDP_UPSTRPRESS,
                "INUSE");
            upstrPress = dbUpstrPress;
        endif;

        if (strType = STREAMTYPE_GASTURB) then

```

```

        connect dbStdDens(s, "CALCALMITEM", CALCALMITEM_GASTURB_STDDENS,
        "INUSE");
        stdDens = dbStdDens;
        connect dbStdCompress(s, "CALCALMITEM",
CALCALMITEM_GASTURB_STDCOMPRESS, "INUSE");
        stdCompress = dbStdCompress;
        connect dbStdTemp(s, "KPREAL", KPREAL_GASTURB_STDTEMP, "VALUE");
        stdTemp = dbStdTemp;
        connect dbUpstrPress(s, "IOASSIGN", IOASSIGN_GASTURB_METERPRESSURE,
        "INUSE");
        upstrPress = dbUpstrPress;
    endif;

# Convert the data
    dim stdDensKgm3;
    call stdDensKgm3 = DensToKgm3(stdDens);

    dim stdTempDegc;
    call stdTempDegc = TempToDegc(stdTemp);

    dim upstrPressBarg;
    call upstrPressBarg = PressToBarg(upstrPress);

# Do the calculation and convert back
    dim upstrDensKgm3 = stdDensKgm3 * (stdCompress * (stdTempDegc +
ABSOLUTE_ZERO) *
        (upstrPressBarg + ATMOSPHERIC_PRESSURE)) / denom;

    dim ndxUpstrDens;
    if (strType = STREAMTYPE_GASDP) then
        ndxUpstrDens = CALCALMITEM_GASDP_UPSTRDENS;
    endif;
    if (strType = STREAMTYPE_GASTURB) then
        ndxUpstrDens = CALCALMITEM_GASTURB_STREAMDENS;
    endif;

    connect dbUpstrDens(s, "CALCALMITEM", ndxUpstrDens, "CALC3");
    call dbUpstrDens = DensFromKgm3(upstrDensKgm3);
endif;

    return 1;
end;

```

### 15.4.6 Perform PTZ Calculations on All Streams

```

#####
# Name:                ptz
# function:            Attempt ptz calculation on all streams.
# Arguments:          -
# return value:       -
#####

function ptz()
    while (1) do
        dim str;
        for str = 1 to numstreams()
            DoStreamPtz(stream(str));
        next;
    wend;
end;

```



## 15.5 LogiCalc Language Specifications

This section provides specifications on the LogiCalc language.

Name	Definition
<b>Supported Types</b>	Decimal Integer (e.g. -999) Binary Integer (e.g. 11001100b) Double Precision Floating Point (e.g. 3.14159265) String (e.g. "hello mum")
<b>Supported Operators</b>	+ - * / ( ) >, <, =, >=, <=, <> AND, OR (boolean) & (bitwise AND),   (Bitwise OR) \$ (string concatenation) <<, >> (Bit shifting)
<b>Supported Statements</b>	function/end, dim, const, let, if/then/else/endif, while/do/wend, for/next, call, return, connect, setalarm/clearalarm/accalarm
<b>Built-in Functions</b>	ioboard(x), station(x), stream(x), numioboards(), numstations(), numstreams(), numobjects(x, "type"), log(x), exp(x), abs(x), int(x), pow(x, y), sin(x), cos(x), tan(x), timenow(), leftstring("string", len), rightstring("string", len), NOT(), NOTB()
<b>Comments</b>	# as first character in a line denotes a comment
<b>Max Program File Line Length</b>	255 chars
<b>Max Variable/Function Name Length</b>	63 chars
<b>Max Chars for String Variable</b>	127 chars
<b>Max Number of ARGs in a Function</b>	16
<b>Variable Names</b>	a-z, A-Z, 0-9 and _. (First char can't be 0-9)
<b>Max Terms in a Single Arithmetic Expression</b>	32
<b>Max LogiCalc Program File Name Length</b>	8.3 characters (S600+ uses FAT) For example, "my_prog.y.lc" is ok; "myprogram.lc" is not.

### 15.5.1 LogiCalc Statements

Use these statements to create custom LogiCalc statements.

**function/end** A program consists of one or more user defined functions in a text file. These functions should be laid out one after the other. The last function found is used as the first one to run. Each function can call the other user-defined functions as long as the functions called are defined earlier in the file (that is, you can only call “upwards”). User defined functions can take any number of arguments. They are evaluated at run time and passed by value. A function can return one value which must be assigned to a variable using the “call” keyword. User functions cannot be used directly in expressions.

```
function <function1_name>(<arg1>, <arg2>, ...)  
.  
.  
.  
end;
```

**dim** Defines a variable for use in the current scope.

```
dim <variable_name>;  
dim <variable_name> = <expression>;
```

**const** Defines a constant for use in the current scope. This is the same as a variable except a value must be assigned at define time and the value cannot be changed (like a #define in C).

```
const <constant_name> = <expression>;
```

**let** Assigns a value to a variable. The let command is optional.

```
let <variable_name> = <expression>;  
<variable_name> = <expression>;
```

**if/then/else/endif** Conditionally changes the path of execution in a program.

```
if <expression> then  
.  
.  
endif;  
  
if <expression> then  
.  
.  
else  
.  
.  
endif;
```

**while/do/wend** Conditionally loops the path of execution in a program.

```
while <expression> do  
.  
.  
wend;
```

**for/next** Loops the path of execution in a program a set number of times. The variable name on the “next” is optional.

```
for <variable_name> = <expression> to <expression>  
.  
.  
next <variable_name>;  
  
for <variable_name> = <expression> to <expression>  
.  
.  
next;
```

**call** Required to call a user function that returns a value. The returned value from a function is assigned to the specified variable. If a return value is not required, just specify the function name on its own without the call keyword.

You can call a function in any of the following three shown examples.

---

**Note:** The third variant works on only version 1.2 and above; avoid using it to ensure compatibility.

---

```
<function_name>(<expression1>, <expression2>, ...);
call <variable_name> = <function_name>(<expression1>, <expression2>, ...);
call <function_name>(<expression1>, <expression2>, ...);
```

**return** Returns a value from a function.

```
return <expression>;
```

**connect** Connects a data point from the S600+ database for use in the program.

```
connect <variable_name>(<expression>, <expression>, <expression>, <expression>);
```

The four valid statement parameters are:

- **Section index:**  
Usually 0 (for system) or derived from stream(x), station(x) or ioboard(x)
- **Data type:**  
A string such as "KPREAL", "KPINT", "KPSTRING", etc.
- **Data index:**  
An index into the data of the section specified in the first argument.
- **Field name:**  
A string representing the field name (which as "INUSE", "VALUE", etc.)

The connect wizard or system editor will help you out specifying these values.

---

**Note:** The variable is only dynamically connected to its data point within the scope of the function to which it is connected. If you pass the variable as a parameter to another function, the function will receive a static snapshot of the value when it was passed in, as in the following:

---

```
function copydouble(in, out)
    out = in * 2;
end;

function main()
    connect adc1(ioboard(1), "ADC", 0, "MEASURED");
    connect dac1(ioboard(1), "DAC", 0, "MEASURED");
    while 1 do
        copydouble(adc1, dac1);
    wend;
end;
```

Although this LogiCalc will compile and run, it will not do anything useful since the 'in' and 'out' variables are not connections; they are just values. The act of passing them into the function 'copydouble' has evaluated them from connected variables (adc1, dac1) to normal variables with values in them (in, out).

**setalarm/clearalarm/  
accalarm** Manipulates S600+ alarms.

```
setalarm <variable_name>(<expression>, <expression>);
```

The two statement parameters are:

- Alarm number (between 0 – 15)
- An alarm value.

The alarm value has no significance apart from that it will print as part of the alarm event message. This only happens if it is non-0 so just pass 0 if no value is required on the printout. You can pass different values (such as setalarm, clearalarm, and accalarm) and they all print out against the relevant alarm event messages.

## 15.5.2 Built-In Functions

LogiCalc provides a number of built in functions you can include directly in expressions to perform common tasks.

**ioboard(x),  
station(x),  
stream(x)** These section index functions return the base index for the specified stream, station, and ioboard section. Typically you would use these functions in a call to connect to index data within a stream.

For example, if you are using a direct index or just a system index, pass zero (0) instead of these functions. For example, to update a variable of known index in stream 2:

```
# Relative stream index for a KPREAL
const INDEX_KPREAL_VISC = 14;
connect strVisc(stream(2), "KPREAL", INDEX_KPREAL_VISC, "VALUE");
strVisc = 0.317;
```

**numioboards(),  
numstations(),  
numstream()** These resource evaluation functions return the number of streams, stations, or I/O modules present in the current running configuration. For example, to iterate through the IO modules:

```
dim io;
for io = 1 to numioboards()
    connect xxx(io, xxxx, xxxx, xxxx);
    ...
next;
```

**numobjects(x, "type")** This object evaluation function returns the number of objects of the specified type present in section (x) of the currently running configuration.

For example, to iterate through all the system keypad ints:

```
dim numints = numobjects(0, "KPINT");
for i = 1 to numints
```

```

connect xxx(0, "KPINT", i, "VALUE");
...
next;

```

**setalarm(x, v), clearalarm(x, v), accalarm(x, v)** These alarm handling functions set, clear, and accept system alarms. The parameters are alarm numbers (0→15) and alarm value (which gets printed).

```

connect adc1(ioboard(1), "ADC", 0, "INUSE");
if (adc1 > 50) then
    setalarm adc1(1, adc1);
else
    clearalarm adc1(1, adc1);
endif;
accalarm adc1(1, 0.0);

```

**timenow()** Provides a snapshot of the system time; useful for working out relative times.

```

while (1) do
    dim t = timenow();
    .
    .
    .
    # Have we taken too long??? (i.e. exceeded 1.5 seconds)
    if (timenow() - t > 1.5) then
        setalarm timeout(0, t);
    endif
wend

```

**log(x)** Provides a natural logarithm.

**exp(x)** Provides an exponential value.

**pow(x, y)** Provides a power function, taking x to the power y. Arguments can be double precision. This function is processor-intensive, so do not use this function in a loop unless it is absolutely necessary.

**abs(x)** Returns the absolute value of x. If x is positive, return x. If x is negative, return -x.

**int(x)** Returns the integer portion of x. Always truncates, so int(1.9) returns 1. If you want to round up, call int(x + 0.5).

**sin(x), cos(x), tan(x)** Provides associated trigonometric functions. X must be in radians. .

**NOT(x), NOTB(x)** NOT() is a Boolean not, and returns 1 or 0 depending on the value of the passed expression, such as:

- NOT(1) = 0
- NOT(0) = 1
- NOT(25.6) = 0

NOTB() is a bitwise NOT, and is typically used for masking bits, as in:

```
function ClearBit(value, bitpos)
    return value & NOTB(1 << bitpos);
end;
```

### 15.5.3 Alarms

**Testing Alarms** You can test for alarms being set or clear, accepted or unaccepted by connecting to ALARM objects, as in:

```
connect adcstatus(ioboard(1), "ALARMS", ALARMS_P144IIIO_IO01ADC01, "STATUS");
connect adcunacc(ioboard(1), "ALARMS", ALARMS_P144IIIO_IO01ADC01, "UNACC");
```

This object allows access to the alarm status of an ADC. The value returned is a 16-bit mask with a 1 in each alarm position representing an alarm that is set or unaccepted, respectively.

To test if alarm 'x' (remember alarms start at 0) is set:

```
if adcstatus & (1 << x) then      # alarm is set
    .
endif;
```

To test if alarm 'x' (remember alarms start at 0) is unaccepted:

```
if adcunacc & (1 << x) then      # alarm is unaccepted
    .
endif;
```

**Suppressing Alarms** Access to the alarm object allows you to suppress and test suppression. For example, To suppress alarm "x" (where x = 0 to 15) on an ADC, connect to an alarm object's "SUPPRESS" field:

```
connect adcsuppress(ioboard(1), "ALARMS", ALARMS_P144IIIO_IO01ADC01,
    "SUPPRESS");
adcsuppress = adcsuppress | (1 << x);
```

The field is a 16-bit mask as are the Status and Unacc fields of the alarm object. Suppressed alarms are represented by a set bit in the mask. Setting a bit in the mask suppresses the alarm. Bear in mind that the above code first reads out the current suppress mask, OR's in a bit and writes it back. This happens pretty quickly but may conflict with anything else that is updating the value. Ensure the LogiCalc is the only task updating the alarm suppression word to avoid missing the odd suppression.

## Appendix A – Glossary

### A

---

<b>ADC</b>	<b>Analog to Digital Converter.</b> Used to convert analog inputs (AI) to a format the flow computer can use. Also known as A/D Converter.
<b>Address</b>	A character or group of characters used to identify a particular item (such as a particular area of memory or a particular computer on a communication link with many other computers).
<b>AGA</b>	<b>American Gas Association.</b> A professional organisation that oversees the AGA3 (orifice), AGA5 (heating value), AGA7 (turbine), AGA8 (compressibility), AGA9 (Ultrasonic) and AGA11 (Coriolis) gas flow calculation standards. See <a href="http://www.aga.org">http://www.aga.org</a> .
<b>AI</b>	<b>Analogue input,</b> also known as ANIN.
<b>Alphanumeric</b>	Consisting of only the letters A through Z and the numbers 0 through 9.
<b>Analogue</b>	A signal with no defined steps, its value being determined by its size.
<b>Annubar</b>	A primary flow element that operates by sensing an impact pressure and a reference pressure through multiple sensing ports connected to dual averaging plenums. The resultant difference is a differential pressure signal. Sensing ports are located on both the up- and downstream sides of the flow element. The number of ports is proportional to the pipe diameter.
<b>ANIN</b>	<b>Analogue input,</b> also known as AI.
<b>ANOUT</b>	<b>Analogue output,</b> also known as AO.
<b>ANSI</b>	<b>American National Standards Institute.</b> An organization responsible for approving U.S. standards in many areas, including computers and communications. Standards approved by this organisation are often called ANSI standards (for example, ANSI C is the version of the C language approved by ANSI). ANSI is a member of ISO. See <a href="http://www.ansi.org">http://www.ansi.org</a> .
<b>ASCII</b>	<b>American Standard Code for Information Interchange.</b> Numeric values assigned to letters, numbers, and other characters to enable exchange of information between devices (for example, "A" = 65, "B"=66, and so on).
<b>AWG</b>	<b>American Wire Gauge,</b> a system of sizing wiring.

### B

---

<b>Back up/backup</b>	The process of copying or creating a duplicate of computer files (called "a backup file") that can be used to restore the original content in the event of a data loss.
<b>Baud</b>	An indicator of the rate of serial data transfer (for example, a baud rate of 10 indicates 10 bits per second).
<b>Basetime</b>	The end of day time when any daily, weekly, or monthly reports print; also known as "contract hour." S600+ supports three basetimes.
<b>Batch control</b>	A system option used to allow a liquid station within the S600+ to control a number of streams to dispatch a precise amount of product. If batch control is required, it should be enabled on all relevant streams and on the station settings during the configuration generation stage.
<b>Baud rate</b>	An indicator of the rate of serial data transfer (for example, a baud rate of 10 indicates 10 bits per second, or approximately 1 character per second).
<b>Binary</b>	Numbers in base 2 (that is, only numbers 0 and 1 are used). May be represented as a digital signal and referred to as True/False, High/Low, or On/Off.
<b>Bit</b>	A <b>binary digit</b> , either a binary 0 or 1. One byte is the amount of memory needed to store each character of information (text or numbers). Eight bits constitute one byte (or character).
<b>Bit Link</b>	A bridge (also known as a jumper) that closes an electrical circuit. Typically a bit link consists of a plastic plug that fits over a pair of protruding pins. Placing a bit link over a different set of pins allows you to change a board's parameters.

<b>Bit switch</b>	Switches that represent data bits by on or off state.
<b>Buffer</b>	A device inserted between devices to match impedance, equipment speeds, or to supply additional drive capability. Also, a storage area for data that compensates for the speed difference when transferring data from one device to another; usually refers to an area reserved for I/O operations into which data is either read or from which data is written.
<b>Bus</b>	One or more conductors used as a path over which information transmits.
<b>Byte</b>	Block of 8 bits, which can define 256 states (0 through 255).

## C

---

<b>Calorific value (CV)</b>	<p>Superior calorific value (CV) is the amount of heat which could be released by the complete combustion in air of a specified quantity of gas, in such a way that the pressure at which the reaction takes place remains constant, and all the products of combustion are returned to the same specified temperature as that of the reactants, all of these products being in the gaseous state except for water formed by combustion, which is condensed to the liquid state (source ISO6976, 1995).</p> <p>CV can also be calculated in accordance with AGA Report No. 5.</p> <p>For inferior calorific value, water remains in a gaseous state (vapour).</p>
<b>CATS</b>	<b>Common Area Transmission System.</b> An agreed standard for measurement of gases and light hydrocarbons which are to be delivered to and redelivered for the CATS Transportation Facilities and Input Facilities (EU only).
<b>Cold Start</b>	A process of starting the FloBoss S600+ that copies the configuration file from Flash memory.
<b>Config600 software</b>	PC-based software tool used to configure the S600+.
<b>Constants</b>	Numbers that only infrequently change. Examples would include the conversion value between Degrees Celsius and Degrees Fahrenheit or pipe diameter.
<b>Control bus</b>	Bus connections for control signals (such as read/write).
<b>CPS</b>	Correction for pressure on steel (of meter or prover)
<b>CPU</b>	<b>Central Processing Unit;</b> in the S600+, the CPU module (P152+).
<b>CTL_CPL</b>	Factors for the <b>C</b> orrection for the temperature of the liquid and <b>c</b> orrection for the pressure of the liquid. In the Calculations portion of the Config600 Configuration Generator, this option is set to include the Liquid Volume Correction Table for a US configuration (tables 23, 24, 53, or 54).
<b>CTS</b>	<b>C</b> lear to <b>S</b> end. The signal asserted (logic "0", positive voltage) by the remote device to inform the flow computer that transmission may begin. RTS and CTS are commonly used as handshaking signals to moderate the flow of data into the remote device.
<b>CTS</b>	Correction for temperature on steel (of meter or prover)
<b>CUI</b>	Daniel USM interface

## D

---

<b>DAC</b>	<b>D</b> igital to <b>A</b> nalog converter, also known as the D/A converter. Used to convert the digital signals used within the S600+ to an analog value for use with an analog transducer or for an analog readout.
<b>Databus</b>	A group of bi-directional lines capable of transferring data to and from the CPU storage and peripheral devices.
<b>DCS</b>	<b>D</b> istributed <b>C</b> ontrol <b>S</b> ystem. A computer system which manages the process of a plant or site.
<b>DCU</b>	<b>D</b> ata <b>C</b> oncentrator <b>U</b> nit. Used to connect one device (such as a printer) to multiple S600s. Control of the shared device is determined by the hardware handshaking lines of the RS-232 port.
<b>Densitometer</b>	Transducer used to measure the density of the product at current conditions in the pipework where it is mounted.
<b>DI</b>	<b>D</b> igital or discrete input, as known as DIGIN.



<b>Digital</b>	A signal with only two states, such as on/off, input/output, or 5V/0V.
<b>DIN</b>	<b>D</b> eutsches <b>I</b> nstitut fur <b>N</b> ormung. German Standard.
<b>Discrepancy</b>	Used to check the difference between a measured variable and a preset value. For example, if Flow Discrepancy was selected during the generation phase, the S600+ would check the current uncorrected volume flow rate against the proved uncorrected volume flow rate. If the discrepancy exceeded the preset limit, the S600+ would raise an alarm indicating that a prove was required. <b>Note:</b> This example is only applicable to a liquid turbine configuration.
<b>DO</b>	<b>D</b> igital or discrete <b>o</b> utput, also known as DIGOUT.
<b>DP</b>	<b>D</b> ifferential <b>P</b> ressure.
<b>DPR</b>	<b>D</b> ual <b>P</b> ulse <b>R</b> eceiver or turbine input.
<b>DRAM</b>	<b>D</b> ynamic <b>R</b> andom- <b>A</b> ccess <b>M</b> emory. Volatile storage memory used in the S600+. When power is removed from the S600+, the contents of the DRAM memory are lost.
<b>DVM</b>	<b>D</b> igital <b>v</b> oltmeter.

---

**E**

<b>E-Format</b>	Mathematical notation where the mantissa is any number greater than -10 and less than 10 and the exponent is the multiplier.
<b>EEPROM</b>	<b>E</b> lectrically <b>E</b> rasable <b>P</b> rogrammable <b>R</b> ead <b>O</b> nly <b>M</b> emory, a non-volatile memory chip which may be erased and reprogrammed electronically.
<b>Ethernet</b>	A 10- or 100-megabit-per-second (Mbps) baseband-type network that uses the contention-based CMA/CD media access method. Invented by Robert Metcalf at Xerox's Palo Alto Research Center in the mid-1970s.
<b>Exponent</b>	Base 10 multiplier.
<b>EU</b>	<b>E</b> uropean <b>U</b> nion.
<b>EU</b>	<b>E</b> ngineering unit

---

**F, G**

<b>Flash memory</b>	Non-volatile storage memory. Although slower to access than SRAM and DRAM, once programmed flash memory retains the data and requires no further support. In the S600+, configuration files and the operating system are typically stored in flash memory. Write protect jumpers are used to prevent accidental programming of flash memory.
<b>Flow Balance</b>	Used to balance the flow through a liquid system so a required flow rate can be attained through a prover.
<b>Flow Switching</b>	This option allows the station within the S600+ to control the number of streams open according to the current flow rates. If flow switching is required it should be enabled on all relevant streams and on the station settings during the generation phase.
<b>FRQ</b>	Frequency input.

---

**H**

<b>HART®</b>	<b>H</b> ighway <b>A</b> dressable <b>R</b> emote <b>T</b> ransducer (or HART) is a communication protocol designed for industrial process measurement and control applications. It combines both analogue and digital communication and can communicate a single variable using a 4-20 mA analogue signal, while also communicating added information on a digital signal.
<b>Hex</b>	Hexadecimal, referring to numbers in base 16 (that is, numbers from 0 through 9 and letters from A through F).
<b>Heating Value (HV)</b>	See Calorific Value (CV).
<b>Holding Register</b>	Analog Output number value to be read.
<b>Hz</b>	Hertz.

## I, J, K

---

<b>Integer</b>	Any positive or negative whole number, including zero.
<b>Intelligent I/O</b>	The Intelligent Input Output module (P144), also known as "IIO".
<b>I/O</b>	Input and <b>O</b> utput.
<b>IP</b>	Institute of <b>P</b> etroleum or Ingress protection standard, referring to British standard 5420 or International Electro-Technical Commission standard 144.
<b>IP2</b>	In the calculations section of the generator, this option includes the Liquid Volume Correction Tables (53 or 54) for a non-US configuration.
<b>IS</b>	<b>I</b> ntrinsic <b>S</b> afety. A technique used to prevent excess electrical energy, or faults, in instrumentation from causing explosions in hazardous atmospheres. Often found in the process industry. It is the only protection method accepted for use in Zone 0 hazardous areas.
<b>ISO</b>	<b>I</b> nternational <b>O</b> rganisation for <b>S</b> tandards. A voluntary, non-treaty organization founded in 1946 which is responsible for creating international standards in many areas, including computers and communications. Its members are the national standards organizations of the 89 member countries, including ANSI for the U.S. See <a href="http://www.iso.org">http://www.iso.org</a> .
<b>ISO 5167</b>	Measurement of fluid flow by means of pressure differential devices (such as orifice plates, nozzles, or Venturi tubes) inserted in circular cross-section conduits.
<b>ISO 6976</b>	Natural gas calculation of calorific values, density, relative density and Wobbe index from composition.

## L

---

<b>LED</b>	<b>L</b> ight- <b>E</b> mitting <b>D</b> iode (an indicator). On the S600+, a light to show the status of the S600+ in a visual form. As examples, the Alarm LED shows the status of the machine by the color of the LED and communications between the main processor board and the IO boards is shown on the rear of the flow computer by use of the transmit and receive LEDs.
------------	---

## M

---

<b>Mantissa</b>	Numerically significant part of a floating-point number.
<b>Meter Correction</b>	An option applicable only to liquid turbine applications and used to correct the flow rate due to temperature and pressure effects on the body of the meter.
<b>Meter Linearisation</b>	An option used to correct the K Factor or Meter Factor of a pulse input according to the input frequency. This is used to correct discrepancies caused by the non-linearity of the transducer connected to the pulse input.
<b>Modbus</b>	A device communications protocol developed by Gould-Modicon and used on the station supervisory computer data link, as well as communicating with Coriolis meters, gas chromatographs, ultrasonic meters, and other devices.
<b>Modem</b>	<b>M</b> odulator <b>D</b> emodulator; a device used to communicate with other equipment using a telephone network.
<b>Modulate</b>	Superimposing one signal upon another.
<b>MOV</b>	<b>M</b> otor <b>O</b> perated <b>V</b> alve; a valve that is motorized and requires a signal to drive the valve open, a signal to drive the valve closed, and has a two signals returning to the S600+ to describe the valve as being open, closed, moving, or illegal.
<b>Multiplexor</b>	Multiple Input Selector.
<b>MVS</b>	Multi-variable sensor

## N

---

<b>Noise</b>	Random electrical interference.
<b>Non-volatile Memory</b>	Memory type that retains data when the power supply is disconnected.
<b>NX-19</b>	An AGA report developed for the calculation of supercompressibility factors.

**O**

---

<b>Object</b>	Generally, any item that can be individually selected and manipulated. This can include shapes and pictures that appear on a display screen as well as less-tangible software entities. In object-oriented programming, for example, an object is a self-contained entity that consists of both data and procedures to manipulate the data.
<b>Octal</b>	Numbers in base 8 (that is, numbers 0 through 8).
<b>Off-line</b>	Accomplished while the target device is not connected (by a communications link). For example, "off-line configuration" refers to configuring an electronic file that is later loaded onto the S600+.
<b>On-line</b>	Accomplished while connected (by a communications link) to the target device. For example, "on-line configuration" refers to configuring an S600+ while connected to it, so you can view the current parameter values and immediately load new values.
<b>Open Collector</b>	Digital output that is driven by a transistor and requires external power.
<b>Opto-Isolator</b>	Optical device for connecting signals while maintaining electrical isolation.
<b>Overrange</b>	Over the preset current limit for the A/D Converter.

**P, Q**

---

<b>PCB</b>	<b>Printed circuit board.</b>
<b>PID</b>	Three-term control action that uses <b>P</b> roportional, <b>I</b> ntegral, and <b>D</b> erivative components to modify a control output, with the goal of achieving a measured process variable at a set point.
<b>Peer to Peer Link</b>	Communications mode implemented by giving each communication node both server and client capabilities.
<b>Port</b>	Group of inputs or outputs to the computer.
<b>Program</b>	Series of instructions.
<b>Protocol</b>	Precise description of data interchange over a telemetry link.
<b>Prove Sequence</b>	An order of events set into the S600+ to perform a calibration (or "prove") of flow balancing, stability checking, or valve-routing.
<b>PRT</b>	<b>Platinum resistance thermometer.</b> See also RTD.
<b>PSU</b>	<b>Power supply unit.</b>
<b>PTZ</b>	Calculation of Compressibility, Relative Density and Line Density using the Solartron 7915 PTZ method.

**R**

---

<b>RAM</b>	<b>Random-access memory.</b> Volatile memory that becomes unreliable when power is removed from the computer.
<b>Relative Density (RD)</b>	Liquid relative density: the ratio of the mass of a given volume of liquid at 15°C (or other standard temperature, such as 60°F) to mass of an equal volume of pure water at the same temperature. When reporting results, explicitly state the standard reference temperature (for example, relative density 15/15°C). [Source API Vocabulary 1994].  Gas relative density: As above except that air is used as the reference instead of water.  Ideal and Real gas relative density. See Specific Gravity.  Note: Water at 15°C is 999.058 kg/m <sup>3</sup> . Water at 60°F is 999.012 kg/m <sup>3</sup> . [Source API 2540 volume X] Air at 15°C is 1.2255 kg/m <sup>3</sup> .
<b>ROM</b>	<b>Read-only memory (fixed storage).</b> Typically used to store firmware. Flash memory. This type of memory cannot be written to by default; however, some modern memory allows writing to occur under certain conditions.
<b>RS-232</b>	Voltage standard for multi-drop serial data transmission. Also EIA-232.
<b>RS-422</b>	Voltage standard for serial data transmission; used as extender for RS-232.

<b>RS-485</b>	Voltage standard for multi-point digital data transmission.
<b>RTD</b>	Resistance thermometer device.
<b>RTS</b>	<b>Request to Send.</b> This signal is asserted (logic '0', positive voltage) to prepare the other device for accepting transmitted data from the flow computer. Such preparation might include enabling the receive circuits, or setting up the channel direction in half-duplex applications. When the other device is ready, it acknowledges by asserting Clear to Send.
<b>RTU</b>	Remote terminal unit.
<b>RTV</b>	Room temperature vulcanizing, typically a sealant or caulk such as silicon rubber.
<b>RX or RXD</b>	Received information.

## S

---

<b>Sampler</b>	Device used to take samples of the product in the pipework where it is mounted. This can either be timed according to throughput or number of samples required in a certain timeframe.
<b>Security Code</b>	Codes that limit operator access to software parameters; typically stored in micro memory.
<b>Specific Gravity (SG)</b>	<p>Ideal gas relative density (specific gravity), <math>G_i</math> is defined as the ratio of the ideal density of the gas to the ideal density of dry air at the same reference conditions of pressure and temperature. Since the ideal densities are defined at the same reference conditions of pressure and temperature, the ratio reduces to a ratio of molar masses (molecular weights). [Source AGA3 1992]</p> <p>Real gas relative density (specific gravity), <math>G_r</math>, is defined as the ratio of the real density of the gas to the real density of dry air at the same reference conditions of pressure and temperature. To correctly apply the real gas relative density (specific gravity) to the flow calculation, the reference conditions for the determination of the real gas relative density (specific gravity) must be the same as the base conditions for the flow calculation. [Source AGA3 1992]</p> <p>See also Relative Density (RD).</p> <p><b>Note:</b> Real relative density differs from ideal relative density in that the ratio of the gas compressibilities is also taken into account.</p>
<b>SRAM</b>	<b>Static random-access memory.</b> Stores data as long as power is applied; typically backed up by a lithium battery or supercapacitor.
<b>S600+</b>	FloBoss™ S600+ Flow Computer.

## T

---

<b>Task</b>	An operating system concept that refers to the combination of a program's execution and the operating system's bookkeeping information. Whenever a program executes, the operating system creates a new task for it.
<b>TCP/IP</b>	<b>Transmission Control Protocol/Internet Protocol.</b>
<b>Time and Flow Averaging</b>	An option that allows the S600+ to average process variables based on time, flow or time and flow.
<b>Totaliser</b>	Area of RAM for integrating totals.
<b>Transducer</b>	Device that converts energy from one state to another.
<b>TRI-REG</b>	<b>Triple register;</b> an area of RAM where data is stored in triplicate, normally used to store totals.
<b>TX</b>	Transmitted information.

## U

---

<b>Underrange</b>	Under the preset current limit for the A/C Converter.
-------------------	---

## V

---

<b>Variables</b>	Changeable values.
------------------	--------------------

<b>V-Cone®</b>	A differential pressure device produced by McCrometer.
<b>Volatile</b>	Memory that is unstable in the absence of power.
<b>VWI</b>	<b>View Interface</b> ; now superseded by the Daniel Ultrasonic Interface.

## **W**

---

<b>Warm Start</b>	An S600+ startup process in which the configuration remains untouched.
<b>Watchdog</b>	A hardware circuit that monitors correct program operation and restarts the program in the event of malfunction.

*[This page is intentionally left blank.]*

## Appendix B – Proving

### In This Chapter

B.1	Bi-Directional (Ball) Prover – Liquid Only .....	B-2
B.1.1	Inputs/Outputs .....	B-3
B.1.2	Communications .....	B-3
B.1.3	Pulse Measurement.....	B-4
B.1.4	Sphere Switch Interface .....	B-5
B.1.5	Valve Interface.....	B-10
B.1.6	Prove Sequence and Control .....	B-11
B.1.7	Prover Run Control Stages .....	B-22
B.1.8	Prove/Stream Data.....	B-31
B.1.9	Prove Reports.....	B-32
B.1.10	Proving Calculations .....	B-34
B.2	Compact Prover – Liquid Only .....	B-42
B.2.1	Inputs/Outputs .....	B-43
B.2.2	Communications .....	B-43
B.2.3	Pulse Measurement.....	B-44
B.2.4	Proving Control Signal Timing .....	B-45
B.2.5	Prove Sequence and Control .....	B-46
B.2.6	Prover Run Control Stages .....	B-56
B.2.7	Run Stage Abort Index .....	B-62
B.2.8	Run Stage Calculation Index.....	B-63
B.2.9	Prove/Stream Data.....	B-63
B.2.10	Prove Reports.....	B-65
B.2.11	Proving Calculations .....	B-66
B.3	Master Meter Prover – Gas and Liquid .....	B-75
B.3.1	Master Meter/Stream combinations.....	B-77
B.3.2	Inputs/Outputs .....	B-78
B.3.3	Communications .....	B-78
B.3.4	Pulse Measurement.....	B-78
B.3.5	Prove Sequence and Control .....	B-79
B.3.6	Prover Run Control Stages .....	B-88
B.3.7	Prove/Stream Data.....	B-94
B.3.8	Prove Reports.....	B-95
B.3.9	Proving Calculations .....	B-97

This appendix provides an overview of the four S600+-supported proving methods—bi-directional, uni-directional, compact, and master meter—and their specifications and applications.

---

**Note:** Refer to *Chapter 5, Station Configuration*, for a discussion of prover configuration screens.

---

The uni-directional prover differs from the bi-directional prover only in the run control sequence described in *Section B.1.7*.

**Station-Based** In Config600 software, proving is a **station-based** function. Each S600+ can support two stations, and you can assign up to 10 streams (depending on the complexity of the configured streams) to each station. The provers do not need to be the same type. However, the S600+ supports only one Prover (P154) module, which means that you can perform only one prove sequence at a time.

**Local or Remote** The software also allows you to prove streams that are “local” (that is, part of the same configuration) or prove streams that are “remote” (in a separate configuration or separate S600+) to the prover.

However, you cannot mix the two (for example, have a prover config with three metering streams and prove a remote, separate stream).

## B.1 Bi-Directional (Ball) Prover – Liquid Only

---

Two components enable you to control the prove:

- **Prove sequence**, a station-based function which sets up the prove environment, and
- **Run control**, a prover-based function which drives the 4-way valve, counts pulses, and performs the K-factor calculations.

Following a successful prove, the system verifies the stream's normal flow rate value:

- If the normal flow rate is set to a value greater than zero (**Aramco-style linearisation**), the run control waits for a predefined amount of time for you to reject the current prove results. If a prove is rejected, the proving report is annotated as "ABORTED". If the time-out elapses, the prove sequence downloads the prove results to the stream being proved and the data is automatically used in the subsequent calculations.
- If the normal flow rate is zero (**non-Aramco-style linearisation**), the prove sequence downloads the prove results to the stream being proved, but does not use the data until it is accepted either locally at the S600+ or via a supervisory computer.

When the prove runs complete, you can either re-run the prove or terminate, at which point (if so configured) the sequence restores the valves to their pre-prove state.

---

### Notes:

- The prove sequence downloads both a K-factor and a meter factor. Applications typically use the original K-factor from the meter calibration report and update the meter factor, which may be either a fixed value or derived from a linearisation process. Alternatively the meter factor can remain unchanged and the K-factor (fixed or linearised) updated.
- The meter factor deviation tests and the historical meter factor database are only supported for "local" streams (part of the same configuration with the prover), if you configure the stream normal flow rate to a value greater than zero and you select "Product Table with History" when you create your configuration.



- You define a ticket as Official or Unofficial when you configure a prove. This selection applies to both the Aramco-style and non-Aramco-style linearisation.

Following an **Official** prove, the prove sequence is determined by the Aramco / non-Aramco style linearisation selection.

Following the **Unofficial** prove, the prove sequence does not download the prove results to the stream being proved. This is typically used to determine an approximate K-Factor / Meter Factor before an official prove takes place or when maintenance activities are being performed on the site.

The Official/Unofficial selection displays in the report header.

### B.1.1 Inputs/Outputs

For bi-directional proving the S600+ requires the following hardware:

- A CPU module (P152+)
- An I/O module (P144)
- A Prover module (P154)

**Inputs** A bi-directional prover normally has the following inputs:

Prover Inlet Pressure	4-20mA ADC
Prover Outlet Pressure	4-20mA ADC
Prover Inlet Temperature	4-wire PRT
Prover Outlet Temperature	4-wire PRT
Stream Raw Pulses	Raw Pulse Input
Prove Enable Status	Digital Input
4-way Valve Forward Status	Digital Input
4-way Valve Reverse Status	Digital Input
4-way Valve Seal Status	Digital Input
4-way Valve Local/Remote Status	Digital Input
Sphere Switches 1 – 4	Switch Inputs 1 – 4

**Note:** If there is only one pressure and temperature input, assign inlet and outlet objects to use the same input.

**Outputs** A bi-directional prover normally has the following outputs:

4-way Valve Forward Command	Digital Output
4-way Valve Reverse Command	Digital Output

### B.1.2 Communications

Using the Modbus protocol, a slave link provides communications with any remote stream flow computers.

- To set up the link at the prover (which is the master), select **Tech/Engineer > Communications > Assignment > Prover Master Link**.
- To set up the Modbus address, select **Tech/Engineer > Communications > Assignment > Prover Master Lin**.

Prover/Stream Link	Default Setting
Modbus RTU Master	Serial RS485 - Comm 5
Prover/Stream Link	9600
	8 bits
	No Parity
	1 stop bit
	Address = 1 (front panel)

- To set up the link at the stream (which is the slave), select **Tech/Engineer > Communications > Assignment > Next > Prover Slave Lin**.

---

**Note:** You can reset the ports, baud rate, number of bits, and parity values through the S600+'s front panel.

---

### B.1.3 Pulse Measurement

The primary function of the prover is to calculate an accurate K-factor or meter factor value for the meter under prove. The bi-directional prover does this by counting the number of pulses from the stream meter and equating them to the known volume of the prover.

The stream flow computer receives a known volume or mass from its meter and transmits a pulse train output (Raw Pulse Output) which represents the number of pulses received, including bad pulse correction. The prove sequence commands the selected stream to turn on its Raw Pulse Output, which allows the prover computer to monitor the pulses from the meter. The prover counts pulses during a proof run, and corrects the count for temperature and pressure.

When the proof run completes, the prover calculates the stream's K-factor from the corrected pulse count and the known prover volume.

---

**Note:** The electrical diagram for the Prover module shows a Raw Pulse Output, but this is not available. You cannot use this raw pulse output to pass pulses input to the Prover module to Raw Pulse Input.

---

**Pulse Gating** When a proof run starts, a sphere launches into the flow and passes forward through the prover, triggering the two sphere detector switches as it goes. The 4-way valve then reverses and the sphere again launches into the flow, passing back through the prover and again triggering the two sphere detector switches.

The raw pulses are counted on both the forward and reverse pass, during the period between the sphere switch detectors being triggered.

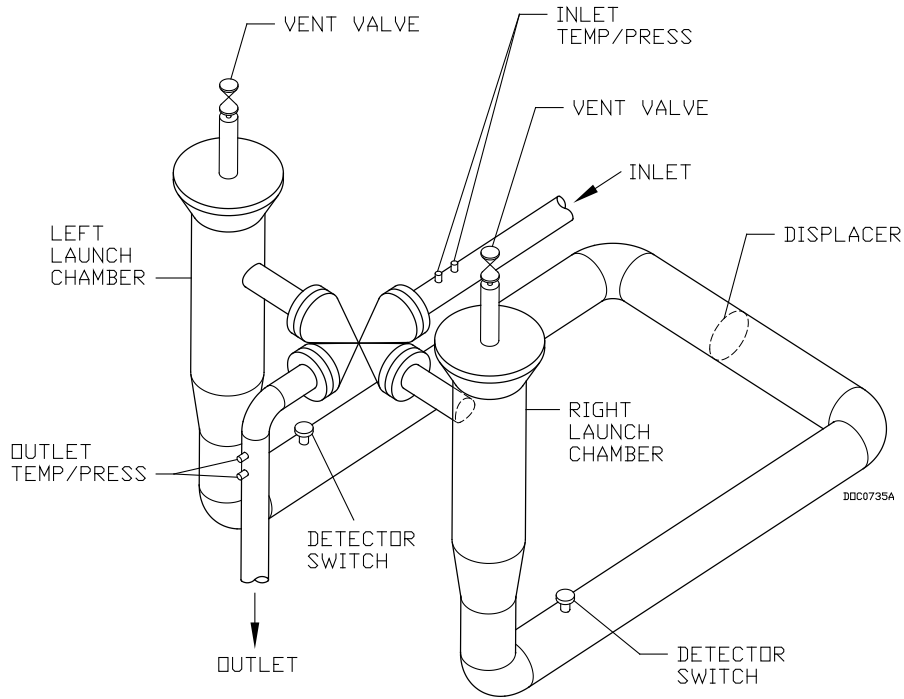

Figure B-1. Components of a Bidirectional Prover

**Pulse Interpolation** Pulse interpolation is used when the pulse count is low (typically less than 10,000 pulses per round trip).

The S600+ supports two methods of pulse interpolation: dual chronometry (the standard) or an optional Pulse Interpolation module (PIM). Either method allows the prover computer to resolve the pulse count to better than the API recommendation of 1 part in 10,000.

Dual chronometry adds accurate timing of the period between detectors so in effect partial pulses can be counted.

If you do not select dual chronometry, you can use a Pulse Interpolation module (PIM) to achieve greater resolution. Using the S600+ keypad, you enter an interpolation factor corresponding to the PIM setting into the S600+ prover.

### B.1.4 Sphere Switch Interface

You can select four possible calibrated (base) volumes, as shown in Figure B-2:

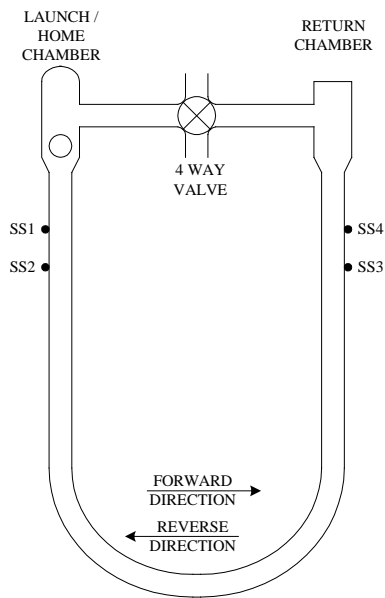

Figure B-2. Sphere Switch Selections

The value for each volume entered represents the “round trip” volume between a pair of sphere switches (that is, twice the calibrated volume). You can enter the calibration conditions through the S600+ keypad. All four switches are connected directly to the prover computer. *Table B-1* through *Table B-4* detail the possible sphere switch selections:

*Table B-1. Bi-Directional Sphere Switch Selections*  
 (Prover mode set to *BIDI 4-WAY* and the number of switches set to 2)

Sphere Switch (SS)	P154 Connections
1 & 2	SS1 = Sw1 (A17) SS2 = Sw3 (A5)

*Table B-2. Bi-Directional Sphere Switch Selections  
(Prover mode set to BIDI 4-WAY and the number of switches set to 4)*

<b>Base Volume</b>	<b>Sphere Switch (SS)</b>	<b>P154 Connections</b>
1	1 & 3	<b>First part of pass:</b> SS1 = Sw1 (A17) SS3 = Sw3 (A5) <b>Return:</b> SS3 = Sw3 (A5) SS1 = Sw1 (A17)
2	2 & 4	<b>First part of pass:</b> SS2 = Sw2 (A18) SS4 = Sw4 (A6) <b>Return:</b> SS4 = Sw4 (A6) SS2 = Sw2 (A18)
3	1 & 4	<b>First part of pass:</b> SS1 = Sw1 (A17) SS4 = Sw4 (A6) <b>Return:</b> SS4 = Sw4 (A6) SS1 = Sw1 (A17)
4	2 & 3	<b>First part of pass:</b> SS2 = Sw2 (A18) SS3 = Sw3 (A5) <b>Return:</b> SS3 = Sw3 (A5) SS2 = Sw2 (A18)

*Table B-3. Type 2  
( Prover mode set to UNITYPE 2)*

<b>Sphere Switch (SS)</b>	<b>P154 Connections</b>
1 & 2	SS1 = Sw1 (A5) SS2 = Sw2 (A17)

*Table B-4. Rotork  
(Prover mode set to UNI ROTORK and the number of switches set to 4)*

<b>Base Volume</b>	<b>Sphere Switch (SS)</b>	<b>P154 Connections</b>
1	1 & 3	SS1 = Sw1 (A17) SS3 = Sw3 (A5)
2	2 & 4	SS2 = Sw2 (A18) SS4 = Sw4 (A6)
3	1 & 4	SS1 = Sw1 (A17) SS4 = Sw4 (A6)
4	2 & 3	SS2 = Sw2 (A18) SS3 = Sw3 (A5)

### B.1.4.1 Number of Switches and Base Volume

The number of switches is selectable between 1, 2 and 4. The base volume you select on the Constants screen is determined by the number of switches you select. For more information, refer to *Section 5.7.2, Prover – Ball(Bi-Directional)*

**If you select 1 switch, use Base Volume 1.**

- This prover has 2 sphere detector switches in parallel, and both switches are wired into Pin 17. Pulses are counted between the 1st hit and 2nd hit of this input.
- This is a special for a particular uni prover manufacturer.

**If you select 2 switches, use Base Volume 1**

- This prover has 2 sphere detector switches which are named as Switch 1 and Switch 2.

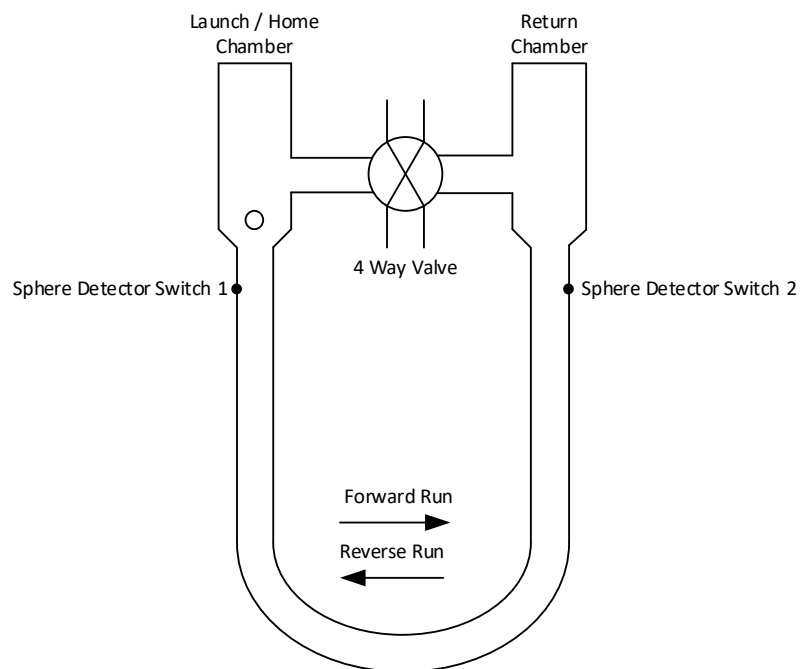

Figure B-3. Two Sphere Switches

- They will register on Pin 17 (Switch 1) and Pin 5 (Switch 2).

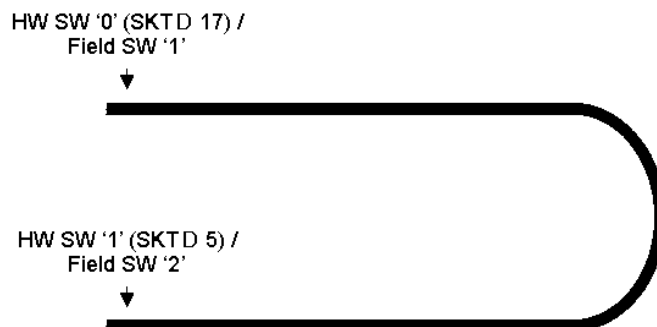
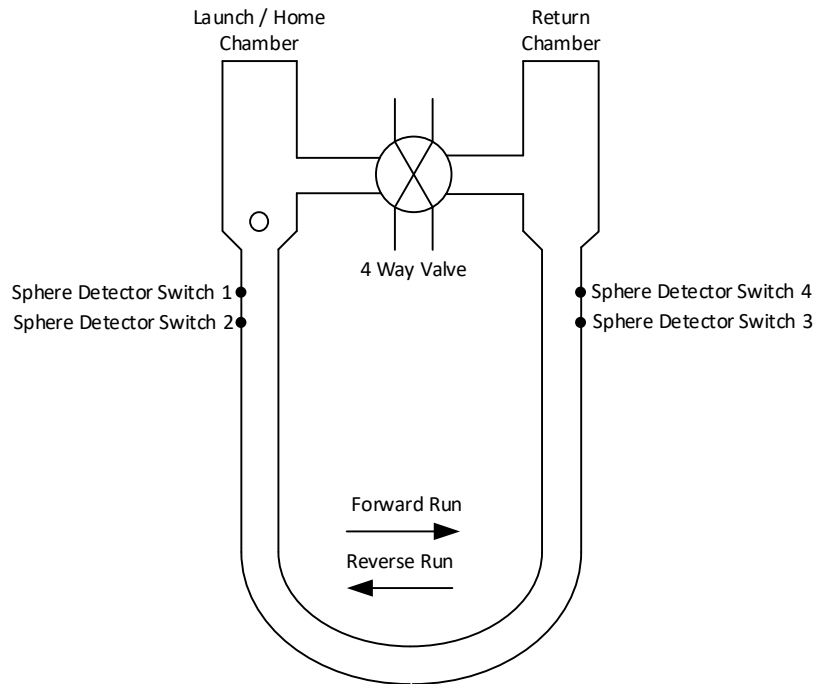

Figure B-4. Pinout for Two Sphere Switches

**If you select 4 switches, the base volume will determine which switches to use.**

- This prover has 4 sphere detector switches which are named as Switch 1, 2, 3 and 4.



*Figure B-5. Four Sphere Switches*

- The Sphere Detector switches will register on the following:  
**Pin 17** – Detector Switch 1  
**Pin 18** – Detector Switch 2  
**Pin 5** – Detector Switch 3  
**Pin 6** – Detector Switch 4

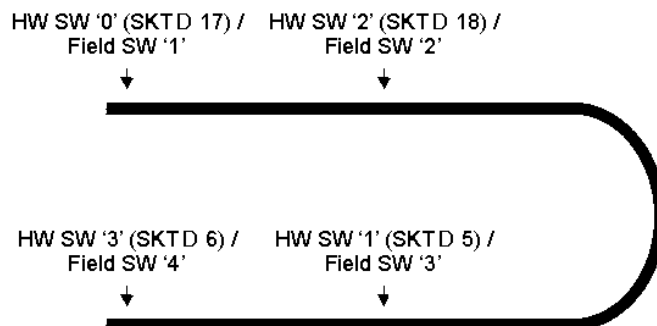

*Figure B-6. Pinout for Four Sphere Switches*

**Note:** The Sphere Detector Switch pinouts will alter based on the 2 switch or 4 switch selection.

## B.1.5 Valve Interface

The flow computer interfaces to a motor-operated 4-way valve. This section discusses the specifics of that valve.

**Operating Mode** The valve has two available modes, **remote** and **local**. The flow computer accepts a digital input signal in order to determine the status of the valve mode. In **remote** mode (the valve’s remote status is “SET”), the S600+ controls the valve. In **local** mode (the valve’s remote status is “CLEAR”), you control the valve manually at the valve.

---

**Note:** If you start a prove when the 4-way valve is in local mode, the run control expects the operator to manually move the valve. The sequence waits indefinitely for the valve to attain the correct position before continuing.

---

**Valve Position Inputs** The prover computer monitors two digital input signals in order to determine the position of the 4-way valve.

Table B-5 shows the interpretation of the two inputs. **1** indicates a contact closure/active signal; **0** indicates an open contact/inactive signal. **CAS2** is the Valve Closed/Reverse Limit switch and **OAS2** is the Valve Open/Forward Limit switch.

For correct operation the Valve Closed Limit switch remains closed until the closed stop is reached, and the Open limit switch remains closed until the Open stop is reached. This means that both inputs are active when the valve is moving and ensures that a valve illegal alarm is raised due to a wiring fault.

Table B-5. Valve Positions

Actual Valve Position	Valve Closed Limit Switch (CAS2)	Valve Open Limit Switch (OAS2)	Flow Computer Valve Closed Input	Flow Computer Valve Open Input
OPEN/FWD	1	0	0	1
MOVING	1	1	1	1
CLOSED/REV	0	1	1	0
FAULT	0	0	0	0

To achieve this operation you must wire the Closed Limit Switch (CAS2) to the flow computer’s valve open input, and wire the Open Limit Switch (OAS2) to the flow computer’s valve closed input.

---

**Note:** If the Limit Switches show the fault state as bits 1/1 not 0/0 there is a work around by swapping the digital inputs for open & closed and inverting the signals.

---

**Valve Command Outputs** Two digital outputs command the valve to move. The forward/reverse output signals can either be held continuously until the valve travel is complete or initiate a pulse where the output is activate for an entered period (such as two seconds).

A valve timeout alarm is raised if the valve position inputs do not reflect the required position within a configurable timeout period. The



timer activates when the flow computer issues the valve move command.

**Valve Seal Detection** The S600+ accepts a digital input signal in order to monitor the position of the seal of the valve.

The operator can enter two parameters: a valve “Settle” time (initialised to 30 seconds) and a “Test” time (initialised to 120 seconds), which starts when the settle time expires.

---

**Note:** The prover does not function correctly if the value is not sealed correctly (without leaks).

---

When the valve attains position, the following events occur:

1. The valve settle time expires.
2. At the expiration of the settle time, the program checks the seal status and raises a Seal Fail alarm if the seal has not set.
3. At the expiration of the test time, the test aborts.

**Valve Travel Time** This represents the time, in seconds, for the valve to reach its commanded position prior to raising a timeout alarm.

**Valve Simulation Mode** Valve simulation is available, accessible through the security-protected display. When the valve simulation mode is enabled, the status line changes when a command has been issued.

**Alarms and Events** The following alarms and events are typically raised on this input.

---

<b>Alarms</b>	<ul style="list-style-type: none"> <li>▪ Valve illegal</li> <li>▪ Valve seal fail</li> <li>▪ Move fail – if status does not change when command issued (when the valve is in remote mode).</li> <li>▪ Move Uncom – if valve status changes when no command has been issued (when the valve is in remote mode).</li> <li>▪ Valve unavailable (when the valve is in local mode)</li> </ul>
<b>Events</b>	Each Mode change (Measured to Keypad) etc.

---

**Note:** If a prove fails (aborts) because of a Seal Fail alarm, you must manually command the valve to move when the seal is made before the prove sequence “knows” the valve is now sealed.

---

### B.1.6 Prove Sequence and Control

Two components enable you to control the prove:

- **Prove sequence**, a station-based function which sets up the prove environment, and
- **Run control sequence**, a prover-based function which drives the 4-way valve, counts pulses, and performs the K-factor and meter factor calculations.

**Note:** In normal operation, the prove sequence automatically controls the run control sequence. However, you can manually control the run control sequence (for example, to diagnose problems).

---

The S600+'s front panel display provides the following commands you can use to control and monitor the two prove control tasks (**Operator > Station > Sequence Ctl**):

Display	Description
SEQ CTL	Operator commands for sequence control (outer loop)
SEQ STREAM NO.	Enter the designated stream number to be proved <b>Note:</b> For local streams, this is the logical stream number. For remote streams, this is the slave number in the Modbus master map. For example, if the first slave has a Modbus address of 22, this is stream 1. If the second slave in the master map has an address of 33, this is stream 2.
SEQ STAGE INDEX	Shows current sequence stage as the sequence progresses.
SEQ STAGE PREV	Indicates the sequence stage immediately prior to the current stage. If an abort occurs, use this value to help identify the source of the abort.
SEQ ABORT INDEX	In the event of a sequence error, an abort reason index will be shown here.
RUN CTL	Operator commands for proof run (inner loop)
Run permit	Interlock required for starting proof run.
Run stage index	Shows current proof run stage as the sequence progresses.
Run abort index	In the event of a proof run sequence error, displays an abort reason index.

Following a successful prove, the system verifies the stream's normal flow rate:

- If the normal flow rate is set to a value greater than zero (**Aramco-style linearisation**), the run control waits for a predefined amount of time for you to reject the current prove results. If a prove is rejected, the proving report is annotated as "ABORTED". If the time-out elapses, the prove sequence downloads the prove results to the stream being proved and the data is automatically used in the subsequent calculations.

- If the normal flow rate is zero (**non-Aramco-style linearisation**), the prove sequence downloads the prove results to the stream being proved, but does not use the data until it is accepted either locally at the S600+ or via a supervisory computer.

You then have two options for accepting the prove results:

- If you select **ACCEPT**, the currently running batch is retroactively adjusted with the new factor.
- If you select **ACCEPT NO ADJUST**, no adjustment is performed on the currently running batch.

### B.1.6.1 Default Prove Sequence Stages

The prover sequence functions in stages. *Table B-6* shows the default stages for a typical application's normal, reprove, and abort situations.

If an abort occurs either automatically or by operator command then the prove sequence stage changes to Aborted. No further action is taken until the computer receives either a Continue command to initiate a re-prove or a Terminate command to finish the sequence.

*Table B-6. Default Prove Sequence Stages*

Stage	Display	Description
0	IDLE	Halted: idle, await Start command
1	INITIALISE	Initialise
2	PULSES ON	Turn proving stream pulses on
8	SEAT SPHERE A	Ensure sphere is in the launch chamber
16	PRV FLOW/T/P STAB	Hold stable temperature, pressure and flowrate
18	PROOF RUN	Perform proof runs (execute Run Control stages)
19	KF DOWNLOAD	K-factor download
20	AWAIT REPROVE	Halted: prove runs complete, await Continue/Terminate command
26	ABORTED STAGE	Halted: sequence aborted, await Continue/Terminate command
<b>Continue (Reprove)</b>		
28	RE-SEAT SPHERE A	Seat sphere
29	RE STAB CHECKS	Hold stable temperature, pressure and flowrate
18	PROOF RUN	Perform proof runs (execute Run Control stages)
<b>Terminate</b>		
21	SEAT SPHERE B	Seat sphere (at end of prove)
25	PS PULSES OFF	Turn off pulses
30	TERMINATE	Terminate (return to idle)

To use stages not included in the sequence you need to create your own sequence file (or two files, if you have configured two provers). Example sequence files are included in C:\Users\\Config600 3.3\pseqlib directory. Copy one of these to C:\Users\\Config600 3.3\Configs\Project\extras directory so that you can download it to the S600+ with the configuration.

**Note:** An explanation of this procedure is provided in *How To No.72* available from SupportNet.

---

## B.1.6.2 Complete Sequence Stage Descriptions

Table B-7 shows all the stages of a prove sequence.

Table B-7. Prove Sequence Stages (Complete)

Stage	Title	Description
0	Idle	Wait for a command to start the sequence, then proceed to stage 1 (Validate and Initialise).
1	Validate + Initialise	<p>Verify:</p> <ul style="list-style-type: none"> <li>▪ The proving stream is flowing.</li> <li>▪ The proving stream is not in maintenance mode.</li> <li>▪ Telemetry to the proving stream is OK.</li> <li>▪ The prove permit state (run control status) is OK.</li> </ul> <p>Initialise:</p> <ul style="list-style-type: none"> <li>▪ Copy the proving stream meter variables into the proving set.</li> <li>▪ Copy the product stream product data into the proving set.</li> <li>▪ Initialise proof run date (via Initialise command to run control task).</li> <li>▪ Determine required proof flowrate from current rate (snapshot) or preset flowrate.</li> <li>▪ Save all FCV settings.</li> </ul> <p>Proceed to stage 2 (Pulses On).</p>
2	Pulses On	<p>Command all online streams to turn pulses off</p> <p>Command proving stream to turn pulses on</p> <p>Wait for pulses to be aligned</p> <p>Proceed to stage 3 (Prover FCV Initialise)</p> <p>Abort:</p> <ul style="list-style-type: none"> <li>▪ If an abort command is issued.</li> <li>▪ If proving stream telemetry fails.</li> <li>▪ If prove permit state (run control status) is off.</li> <li>▪ If no flow at proving stream.</li> <li>▪ If proving stream raw pulse output is not switched on.</li> <li>▪ If proving stream is in maintenance mode.</li> <li>▪ If peer status is not duty.</li> </ul>
3	Prover FCV initialise	<p>Set prover FCV manual output to initial output</p> <p>Set prover FCV mode to manual</p> <p>Set proving stream FCV tracking on</p> <p>Set proving stream FCV mode to manual</p> <p>Proceed to stage 4 (Open prover outlet)</p> <p>Abort:</p> <ul style="list-style-type: none"> <li>▪ If an abort command is issued.</li> <li>▪ If proving stream telemetry fails.</li> <li>▪ If prove permit state (run control status) is off.</li> <li>▪ If no flow at proving stream.</li> <li>▪ If proving stream raw pulse output is not switched on.</li> <li>▪ If proving stream is in maintenance mode.</li> <li>▪ If peer status is not duty.</li> </ul>

Stage	Title	Description
4	<b>Prover open outlet</b>	<p>Command Prover Outlet Valve to open            Wait for valve to reach position            Proceed to stage 5 (Non-proving stream close prover inlet)            Abort:</p> <ul style="list-style-type: none"> <li>▪ If an abort command is issued.</li> <li>▪ If proving stream telemetry fails.</li> <li>▪ If prove permit state (run control status) is off.</li> <li>▪ If no flow at proving stream.</li> <li>▪ If proving stream raw pulse output is not switched on.</li> <li>▪ If proving stream is in maintenance mode.</li> <li>▪ If peer status is not duty.</li> <li>▪ If the valve fails to reach position.</li> </ul>
5	<b>Non-proving stream close prover inlet</b>	<p>Command non-proving streams Prover Inlet Valves to close            Wait for valves to reach position            Proceed to stage 6 (Proving stream open prover inlet)            Abort:</p> <ul style="list-style-type: none"> <li>▪ If an abort command is issued.</li> <li>▪ If proving stream telemetry fails.</li> <li>▪ If prove permit state (run control status) is off.</li> <li>▪ If no flow at proving stream.</li> <li>▪ If proving stream raw pulse output is not switched on.</li> <li>▪ If proving stream is in maintenance mode.</li> <li>▪ If peer status is not duty.</li> <li>▪ If the valves are not correctly aligned.</li> <li>▪ If the valve fails to reach position.</li> </ul>
6	<b>Proving stream open prover inlet</b>	<p>Command proving streams Prover Inlet Valve to open            Wait for valve to reach position            Proceed to stage 7 (Proving stream close stream outlet)            Abort:</p> <ul style="list-style-type: none"> <li>▪ If an abort command is issued.</li> <li>▪ If proving stream telemetry fails.</li> <li>▪ If prove permit state (run control status) is off.</li> <li>▪ If no flow at proving stream.</li> <li>▪ If proving stream raw pulse output is not switched on.</li> <li>▪ If proving stream is in maintenance mode.</li> <li>▪ If peer status is not duty.</li> <li>▪ If the valves are not correctly aligned.</li> <li>▪ If the valve fails to reach position.</li> </ul>
7	<b>Proving stream close stream outlet</b>	<p>Command proving streams Outlet Valve to close            Wait for valve to reach position            Proceed to stage 8 (Seat sphere A)            Abort:</p> <ul style="list-style-type: none"> <li>▪ If an abort command is issued.</li> <li>▪ If proving stream telemetry fails.</li> <li>▪ If prove permit state (run control status) is off.</li> <li>▪ If no flow at proving stream.</li> <li>▪ If proving stream raw pulse output is not switched on.</li> <li>▪ If proving stream is in maintenance mode.</li> <li>▪ If peer status is not duty.</li> <li>▪ If the valves are not correctly aligned.</li> <li>▪ If the valve fails to reach position.</li> </ul>

Stage	Title	Description
8	<b>Synchronise with Run Control (Seat sphere A)</b>	<p>Command 4-way valve to reverse (via Seat Sphere command to run control task).                      Wait for valve to reach position                      Proceed to stage 9 (Non-proving stream FCV track) or stage 16 (Temperature / Pressure Stability)                      Abort:</p> <ul style="list-style-type: none"> <li>▪ If an abort command is issued.</li> <li>▪ If proving stream telemetry fails.</li> <li>▪ If prove permit state (run control status) is off.</li> <li>▪ If no flow at proving stream.</li> <li>▪ If proving stream raw pulse output is not switched on.</li> <li>▪ If proving stream is in maintenance mode.</li> <li>▪ If peer status is not duty.</li> <li>▪ If the valves are not correctly aligned.</li> <li>▪ If the valve fails to reach position.</li> </ul>
9	<b>Non-proving stream FCVS track</b>	<p>Set FCV for non-proving streams to tracking                      Proceed to stage 10 (Non-proving stream flow balance)                      Abort:</p> <ul style="list-style-type: none"> <li>▪ If an abort command is issued.</li> <li>▪ If proving stream telemetry fails.</li> <li>▪ If prove permit state (run control status) is off.</li> <li>▪ If no flow at proving stream.</li> <li>▪ If proving stream raw pulse output is not switched on.</li> <li>▪ If proving stream is in maintenance mode.</li> <li>▪ If peer status is not duty.</li> <li>▪ If the valves are not correctly aligned.</li> </ul>

Stage	Title	Description
10	<b>Non-proving stream flow balance</b>	<p>Enable flow balancing for non-proving streams</p> <p>Flow error = proving stream flowrate - (selected proof flowrate + offset).</p> <p>If the error is too low then:</p> <ul style="list-style-type: none"> <li>▪ If there are no on-line streams then go to abort stage.</li> <li>▪ Turn down value = abs (error / no. of on line none proving streams).</li> <li>▪ For each on line proving stream, new setpoint = current rate - turn down.</li> </ul> <p>If all new set points (for each stream) are within the low flow range then download the new set points and delay for adjustment prior to rechecking the flow error.</p> <p>If any new set point is less than the low flow range then go to stage 12 (operator close)</p> <p>If the error is too high then:</p> <ul style="list-style-type: none"> <li>▪ If there are no on-line streams then go to abort stage.</li> <li>▪ Turn up value = error / no. of on line none proving streams.</li> <li>▪ For each on line proving stream, new setpoint = current rate + turn up.</li> </ul> <p>If all new set points (for each stream) are within the high flow range then download the new set points and delay for adjustment prior to rechecking the flow error.</p> <p>If any new set point is higher than the low flow range then go to stage 13 (operator open).</p> <p>Proceed to stage 14 if the error is within tolerance (Non-proving stream FCV manual).</p> <p>Abort:</p> <ul style="list-style-type: none"> <li>▪ If an abort command is issued.</li> <li>▪ If proving stream telemetry fails.</li> <li>▪ If prove permit state (run control status) is off.</li> <li>▪ If no flow at proving stream.</li> <li>▪ If proving stream raw pulse output is not switched on.</li> <li>▪ If proving stream is in maintenance mode.</li> <li>▪ If peer status is not duty.</li> <li>▪ If the valves are not correctly aligned.</li> <li>▪ If the valve fails to reach position.</li> <li>▪ If flow balance is not achieved (timeout / hold fails).</li> </ul>
11	<b>Not used</b>	
12	<b>Close suspend</b>	<p>Flow balancing – wait for operator to close stream</p> <p>Return to flow balancing stage 10 if continue command issued</p> <p>Abort:</p> <ul style="list-style-type: none"> <li>▪ If an abort command is issued.</li> <li>▪ If proving stream telemetry fails.</li> <li>▪ If prove permit state (run control status) is off.</li> <li>▪ If no flow at proving stream.</li> <li>▪ If proving stream raw pulse output is not switched on.</li> <li>▪ If proving stream is in maintenance mode.</li> <li>▪ If peer status is not duty.</li> <li>▪ If the valves are not correctly aligned.</li> <li>▪ If the valve fails to reach position.</li> <li>▪ If flow balance is not achieved (timeout / hold fails).</li> </ul>

<b>Stage</b>	<b>Title</b>	<b>Description</b>
<b>13</b>	<b>Open suspend</b>	Flow balancing – wait for operator to open stream Return to flow balancing stage 10 if continue command issued Abort: <ul style="list-style-type: none"> <li>▪ If an abort command is issued.</li> <li>▪ If proving stream telemetry fails.</li> <li>▪ If prove permit state (run control status) is off.</li> <li>▪ If no flow at proving stream.</li> <li>▪ If proving stream raw pulse output is not switched on.</li> <li>▪ If proving stream is in maintenance mode.</li> <li>▪ If peer status is not duty.</li> <li>▪ If valves are not correctly aligned.</li> <li>▪ If the valve fails to reach position.</li> <li>▪ If flow balance is not achieved (timeout / hold fails).</li> </ul>
<b>14</b>	<b>Non-proving stream FCVS manual</b>	Set all non-proving stream FCV tracking on Set all non-proving stream FCV mode to manual Proceed to stage 15 (Prover flowrate stability) Abort: <ul style="list-style-type: none"> <li>▪ If an abort command is issued.</li> <li>▪ If proving stream telemetry fails.</li> <li>▪ If prove permit state (run control status) is off.</li> <li>▪ If no flow at proving stream.</li> <li>▪ If proving stream raw pulse output is not switched on.</li> <li>▪ If proving stream is in maintenance mode.</li> <li>▪ If peer status is not duty.</li> <li>▪ If the valves are not correctly aligned.</li> </ul>
<b>15</b>	<b>Prover flowrate stability</b>	Set prover FCV to selected prove flow rate + offset Set prover FCV mode to auto Set prover FCV tracking to on Hold proving stream flow rate within tolerance for a user configurable time Proceed to stage 16 (Temperature / Pressure Stability) Abort: <ul style="list-style-type: none"> <li>▪ If an abort command is issued.</li> <li>▪ If proving stream telemetry fails.</li> <li>▪ If prove permit state (run control status) is off.</li> <li>▪ If no flow at proving stream.</li> <li>▪ If proving stream raw pulse output is not switched on.</li> <li>▪ If proving stream is in maintenance mode.</li> <li>▪ If peer status is not duty.</li> <li>▪ If the valves are not correctly aligned.</li> <li>▪ If stability not achieved.</li> </ul>



Stage	Title	Description
16	<b>Synchronise with Run Control (Temperature / pressure stability)</b>	<p>Hold stability for a user-configurable time            Proceed to stage 17 (Prover FCV manual)</p> <p>Abort:</p> <ul style="list-style-type: none"> <li>▪ If an abort command is issued.</li> <li>▪ If proving stream telemetry fails.</li> <li>▪ If prove permit state (run control status) is off.</li> <li>▪ If no flow at proving stream.</li> <li>▪ If proving stream raw pulse output is not switched on.</li> <li>▪ If proving stream is in maintenance mode.</li> <li>▪ If peer status is not duty.</li> <li>▪ If the valves are not correctly aligned.</li> <li>▪ If stability not maintained.</li> </ul>
17	<b>Prover FCV manual</b>	<p>Set prover FCV tracking on            Set prover FCV mode to manual            Proceed to stage 18 (Proof runs)</p> <p>Abort:</p> <ul style="list-style-type: none"> <li>▪ If an abort command is issued.</li> <li>▪ If proving stream telemetry fails.</li> <li>▪ If prove permit state (run control status) is off.</li> <li>▪ If no flow at proving stream.</li> <li>▪ If proving stream raw pulse output is not switched on.</li> <li>▪ If proving stream is in maintenance mode.</li> <li>▪ If peer status is not duty.</li> <li>▪ If the valves are not correctly aligned.</li> </ul>
18	<b>Synchronise with Run Control (Proof runs)</b>	<p>Start the prove runs (via Start command to run control task).            On success proceed to stage 19 (KF download)</p> <p>Abort:</p> <ul style="list-style-type: none"> <li>▪ If a run fails (such as a timeout for a sphere switch).</li> <li>▪ If an abort command is issued.</li> <li>▪ If proving stream telemetry fails.</li> <li>▪ If prove permit state (run control status) is off.</li> <li>▪ If no flow at proving stream.</li> <li>▪ If proving stream raw pulse output is not switched on.</li> <li>▪ If proving stream is in maintenance mode.</li> <li>▪ If peer status is not duty.</li> <li>▪ If the valves are not correctly aligned.</li> </ul>
19	<b>K-factor Download</b>	<p>Copy proof K-factor, meter factor, flow rate, and frequency into proving stream data points for subsequent telemetry download.</p> <p><b>Notes:</b></p> <ul style="list-style-type: none"> <li>▪ The stream metering calculations do not use these until commanded separately.</li> <li>▪ If the historical meter factor option is enabled then the historical meter factors and deviations arrays are also copied.</li> </ul> <p>Proceed to stage 20 (Await reprove)</p>
20	<b>Await reprove</b>	<p>Go to stage 21 (Seat sphere B) if the Terminate or abort command is issued.</p> <p>Go to stage 28 (Re-seat Sphere) if Continue (Reprove) command is issued.</p>

<b>Stage</b>	<b>Title</b>	<b>Description</b>
21	<b>Synchronise with Run Control (Seat sphere B)</b>	<p>Command 4-way valve to reverse (via Seat Sphere command to run control task).                      Wait for valve to reach position                      Proceed to stage 22 (Proving stream open stream outlet)                      Abort:</p> <ul style="list-style-type: none"> <li>▪ If an abort command is issued.</li> <li>▪ If proving stream telemetry fails.</li> <li>▪ If prove permit state (run control status) is off.</li> <li>▪ If no flow at proving stream.</li> <li>▪ If proving stream raw pulse output is not switched on.</li> <li>▪ If proving stream is in maintenance mode.</li> <li>▪ If peer status is not duty.</li> <li>▪ If the valve fails to reach position.</li> </ul>
22	<b>Proving stream open stream outlet</b>	<p>Command proving stream Outlet Valve to open                      Wait for valve to reach position                      Proceed to stage 23 (Proving stream close prover inlet)                      Abort:</p> <ul style="list-style-type: none"> <li>▪ If an abort command is issued.</li> <li>▪ If proving stream telemetry fails.</li> <li>▪ If prove permit state (run control status) is off.</li> <li>▪ If no flow at proving stream.</li> <li>▪ If proving stream raw pulse output is not switched on.</li> <li>▪ If proving stream is in maintenance mode.</li> <li>▪ If peer status is not duty.</li> <li>▪ If valve fails to reach position.</li> </ul>
23	<b>Proving stream close prover inlet</b>	<p>Command proving stream Prover Inlet Valve to close                      Wait for valve to reach position                      Proceed to stage 24 (Restore FCV) or stage 25 (Proving stream pulses off)                      Abort:</p> <ul style="list-style-type: none"> <li>▪ If an abort command is issued.</li> <li>▪ If proving stream telemetry fails.</li> <li>▪ If prove permit state (run control status) is off.</li> <li>▪ If no flow at proving stream.</li> <li>▪ If proving stream raw pulse output is not switched on.</li> <li>▪ If proving stream is in maintenance mode.</li> <li>▪ If peer status is not duty.</li> <li>▪ If the valve fails to reach position.</li> </ul>
24	<b>Restore FCVS</b>	<p>Reset FCV's to previous (pre-prove) settings as noted in stage 1                      Proceed to stage 25 (Proving stream pulses off)                      Abort:</p> <ul style="list-style-type: none"> <li>▪ If an abort command is issued.</li> <li>▪ If proving stream telemetry fails.</li> <li>▪ If prove permit state (run control status) is off.</li> <li>▪ If no flow at proving stream.</li> <li>▪ If proving stream raw pulse output is not switched on.</li> <li>▪ If proving stream is in maintenance mode.</li> <li>▪ If peer status is not duty</li> </ul>

Stage	Title	Description
25	<b>Proving stream pulses off</b>	Command proving stream to turn pulses off. Wait for the pulses to be turned off Proceed to stage 1 Abort: <ul style="list-style-type: none"> <li>▪ If an abort command is issued.</li> <li>▪ If proving stream telemetry fails.</li> <li>▪ If prove permit state (run control status) is off.</li> <li>▪ If no flow at proving stream.</li> <li>▪ If proving stream is in maintenance mode.</li> <li>▪ If peer status is not duty</li> </ul>
26	<b>Aborted stage</b>	An abort condition has occurred. Go to the next relevant stage if the Terminate command is issued. Go to stage 28 (Re-seat Sphere) if Continue (Reprove) command is issued.
27	<b>Not used</b>	
28	<b>Synchronise with Run Control (Re seat sphere A)</b>	Command 4-way valve to reverse (via Seat Sphere command to run control task). Wait for valve to reach position Proceed to stage 29 (Stability Checks) Abort: <ul style="list-style-type: none"> <li>▪ If an abort command is issued.</li> <li>▪ If proving stream telemetry fails.</li> <li>▪ If prove permit state (run control status) is off.</li> <li>▪ If no flow at proving stream.</li> <li>▪ If proving stream raw pulse output is not switched on.</li> <li>▪ If proving stream is in maintenance mode.</li> <li>▪ If peer status is not duty.</li> <li>▪ If the valve fails to reach position.</li> </ul>
29	<b>Synchronise with Run Control (Stability checks)</b>	Wait to achieve stability (via Stabilise command to run control task) for temperatures, pressure rate of change. Upon achieving stability, wait for stability to be held for a user-configurable time. Proceed to the stage 18 (Proof runs).
30	<b>Terminate</b>	Ensure the run control sequence terminates. Return to stage 1 (Idle).
31 to 40	<b>User Stages</b>	Requires the implementation of the expseq.txt file and a logicalc to perform any specific functionality.
41	<b>Not used</b>	
42	<b>User Comms Suspend 1</b>	Suspends the prover / stream communications. Requires the implementation of the expseq.txt file and a logicalc to perform any specific functionality.
43	<b>User Comms Normal 1</b>	Re-enables the prover / stream communications. Requires the implementation of the expseq.txt file and a logicalc to perform any specific functionality.
44	<b>User Comms Suspend 2</b>	Suspends the prover / stream communications. Requires the implementation of the expseq.txt file and a logicalc to perform any specific functionality.
45	<b>User Comms Normal 2</b>	Re-enables the prover / stream communications. Requires the implementation of the expseq.txt file and a logicalc to perform any specific functionality.

### B.1.6.3 Prove Sequence Abort Index

*Table B-8* shows the abort values for a prove sequence.

Table B-8. Prove Sequence Abort Index

Value	Display	Description
1	OP ABORT	Operator Requested Abort
2	Not Used	
3	PS TELEM FAIL	Proving Stream Telemetry Fail
4	RUN CTL BUSY	Run Control Task Busy
5	METER NO FLOW	No Flow at Meter
6	RUN CTL ABORT	Run Control Task Aborted
7	ILLEGAL PULSES	More than one stream has raw pulses enabled
8	ANY TELEM FAIL	Non Proving Stream Telemetry Fail
9	NPS PRV I-VLV OPEN	Non Proving Stream Prover Valve Not Closed
10	PS PRV I-VLV CLOSED	Proving Stream Prover Offtake Valve Not Open
11	PS STR O-VLV OPEN	Proving Stream Outlet Valve Not Closed
12	PRV I-VLV CLOSED	Prover Inlet Valve Not Open
13	PRV O-VLV CLOSED	Prover Outlet Valve Not Open
14	PS IN MAINT	Proving Stream Is In Maintenance Mode
15	FBAL TIMEOUT	Flow Balance Timeout
16	FBAL NO NPS ON LINE	Flow Balance Error - No Non Proving Streams On-line
17	FBAL NO NPS IN AUTO	Flow Balance Error - No Non Proving Streams In Auto
18	FBAL HOLD FAIL	Flow Balance Error - Stability Not Achieved
19	PS I-SL-VLV CLOSED	Proving Stream Inlet Isolation Valve Not Open
20	PS O-ISL-VLV CLOSED	Proving Stream Header Isolation Valve Not Open
21	PS P-ISL-VLV CLOSED	Proving Stream Prover Isolation Valve Not Open
22	PEER STATUS STANDBY	Unit is in standby mode when peer-to-peer is configured

### B.1.7 Prover Run Control Stages

The Run Control sequence is specific to the type of prover (such as a ball prover, a compact prover, or a master meter). The Run Control sequence initiates the prove runs and performs the calculations that produce a K-factor and meter factor when the runs complete.

Normally the sequence runs when commanded by the Prove Sequence at stage 18 (Perform Proof Runs). However, you can initiate the sequence from the S600+ front panel display or (by using custom controls) from elsewhere.

Table B-9 shows the default stage sequencing for a typical bi-directional prove.

Table B-9. Bi-Directional Prover Run Control Stages

Stage	Display	Description
0	IDLE	Halted: idle
1	INITIALISE	Initialise run data
2	AWAIT SEAT CMD	Halted: await Seat Sphere command
3	SEAT SPHERE A	Seat sphere (drive 4-way valve to reverse)
4	POST SEAT SPHERE A	Delay to allow sphere to fully seat
5	AWAIT STAB CMD	Halted: await Stabilise command
6	WAIT STAB	Wait until stability is achieved
8	AWAIT RUN CMD	Halted: await start runs command
9	DRIVE FORWARD	Drive 4-way valve to forward

Stage	Display	Description
10	FORWARD WAIT SW1	Wait switch 1 hit (forward run)
11	FORWARD WAIT SW2	Wait switch 2 hit (forward run)
23	BI HALF RUN COMP	Bidi half run complete
12	HALF RUN CALCS	Perform half run calculations
13	TURN RND1 DELAY	Delay for turn around
14	DRIVE REVERSE	Drive 4-way valve to reverse
15	REVERSE WAIT SW2	Wait switch 2 hit (reverse run)
16	REVERSE WAIT SW1	Wait switch 1 hit (reverse run)
17	FULL RUN CALCS	Perform full run calculations
18	RUN AVG CALCS	Perform run average calculations
19	STD RPT CHECKS	Perform repeatability checks (if success go to stage 25)
26	CHECK RUNS EXCEEDED	Check runs exceeded (if yes go to stage 21)
20	TURN RND2 DELAY	Delay for turn around (then go to stage 9)
25	FINAL AVG	Perform final average calculations
27	MF DEVIATION CHECKS	Perform meter factor deviation checks. This stage occurs only if you configure the meter normal flow rate to a value greater than zero. <b>Note:</b> This stage is performed <b>only</b> if you configure the meter normal flow to a value greater than zero ( <b>Aramco-style linearisation</b> ) and you select “Product Table with History” when you create your configuration.
28	WAIT REJECT COMMAND	Allow a time-out for rejecting the current prove. If the time-out elapses then print the proof report. This stage occurs only if you configure the meter normal flow rate to a value greater than zero. <b>Note:</b> This stage is performed <b>only</b> if you configure the meter normal flow to a value greater than zero ( <b>Aramco-style linearisation</b> ).
21	FINAL	Halted: final – await Terminate/Reprove command

**Uni-directional** A configuration option (Prover Mode) on the PCSetup Run Data screen enables you to run a uni-directional prover. In a sequence similar to the one shown in *Table B-9*, the uni-directional prover uses stage 24 instead of stage 23 and bypasses the return stages 12 through 16.

**User Stages** You can also enable user stages on the PC Setup Run Data screen. These invoke a LogiCalc which you can edit to provide user specific logic as the prove progresses.

The folder C:\Users\\Config600 3.3\lclib\prover includes example LogiCalcs.

First, copy one of these to the C:\Users\\Config600 3.3\Configs\Project\LogiCalc directory so that you can download it to the S600+ with the configuration so you can edit it to be compatible with your configuration and then download it to the S600+ with the configuration.

**Note:** You must edit the LogiCalc file to connect to the correct objects in your configuration.

**Note:** The displays showing the switch hit only update during a prove. You cannot use them independently to test the hardware.

---

### B.1.7.1 Run Control Stage Description

Table B-10 shows all the stages of a Run Control sequence in bi- and uni-directional provers.

Table B-10. Prover Run Control Stages

Run Stage	Description
<b>0</b>	<b>Idle</b> Wait for the Initialise command to start the Run Control sequence. Proceed to next stage only if the prove is permitted (that is, if the Run Control stage is Idle or Final <b>and</b> the available signal is zero; normally, the available signal is assigned to a digital input which may be connected to a valve or a key-switch).
<b>1</b>	<b>Initialise Run Data</b> Zero down all run data and arrays. Proceed to next stage.
<b>2</b>	<b>Halted: Await Seat Sphere Command</b> Wait for Seat Sphere command then proceed to next stage. Abort: <ul style="list-style-type: none"> <li>▪ If the prove is no longer permitted.</li> <li>▪ If the base volume has changed.</li> <li>▪ If the Terminate command is issued.</li> </ul>
<b>3</b>	<b>Seat The Sphere (Drive 4-Way Valve To Reverse)</b> Issue hardware command to drive 4-way valve to reverse then wait for valve to travel to reverse. Proceed to next stage upon reaching reverse. Abort: <ul style="list-style-type: none"> <li>▪ If the prove is no longer permitted.</li> <li>▪ If the base volume has changed.</li> <li>▪ If the Terminate command is issued.</li> <li>▪ If the 4-way valve raises Move Fail or Leak alarms.</li> </ul>
<b>4</b>	<b>Delay To Allow Sphere To Seat</b> Delay for a period (estimated from flowrate and the selected base volume) to allow sphere to fully seat, then proceed to next stage. A flow uncertainty value of 1.5 is also used in the calculation of travel time (Travel time = ((Base Volume * 3600) / Flow Rate) * Flow Uncertainty). Abort: <ul style="list-style-type: none"> <li>▪ If the prove is no longer permitted.</li> <li>▪ If the base volume has changed.</li> <li>▪ If the Terminate command is issued.</li> </ul>
<b>5</b>	<b>Halted: Await Stabilise Command</b> Wait for Stabilise command then proceed to next stage. Abort: <ul style="list-style-type: none"> <li>▪ If the prove is no longer permitted.</li> <li>▪ If the base volume has changed.</li> <li>▪ If the Terminate command is issued.</li> </ul>

<b>Run Stage</b>	<b>Description</b>
<b>6</b>	<b>Wait Until Stability Is Achieved</b> Proceed to next stage if stability override is on. Set stability wait timer running. Continuously monitor deviations for: <ul style="list-style-type: none"><li>▪ prover inlet pressure vs. prover outlet pressure</li><li>▪ meter pressure vs. prover inlet pressure</li><li>▪ meter pressure vs. prover outlet pressure</li><li>▪ prover inlet temperature vs. prover outlet temperature</li><li>▪ meter temperature vs. prover inlet temperature</li><li>▪ meter temperature vs. prover outlet temperature</li></ul> Continuously monitor (over 5-second periods) rates of change for: <ul style="list-style-type: none"><li>▪ prover inlet pressure</li><li>▪ prover outlet pressure</li><li>▪ prover inlet temperature</li><li>▪ prover outlet temperature</li><li>▪ meter flowrate</li></ul> Proceed to next stage when stability is achieved. Abort: <ul style="list-style-type: none"><li>▪ If the prove is no longer permitted.</li><li>▪ If the base volume has changed.</li><li>▪ If Terminate command is issued.</li><li>▪ If stability wait timer expires.</li></ul>
<b>7</b>	<b>Hold Stability For Entered Period</b> Proceed to next stage if stability override is on. Set stability hold timer running. Repeat the stability checks from the previous stage to ensure stability is maintained for the given period. Proceed to next stage when stability hold timer expires. Abort: <ul style="list-style-type: none"><li>▪ If the prove is no longer permitted.</li><li>▪ If the base volume has changed.</li><li>▪ If the Terminate command is issued.</li><li>▪ If any of the stability checks fail.</li></ul>
<b>8</b>	<b>Halted: Await Start Runs Command</b> Wait for Start Runs command then proceed to next stage. Abort: <ul style="list-style-type: none"><li>▪ If the prove is no longer permitted.</li><li>▪ If the base volume has changed.</li><li>▪ If the Terminate command is issued.</li></ul>
<b>9</b>	<b>Drive 4-Way Valve To Forward</b> Issue command to reset the prover hardware. Issue hardware command to drive the 4-way valve to forward then wait for the valve to travel to the forward position. Proceed to next stage upon reaching forward. Abort: <ul style="list-style-type: none"><li>▪ If the prove is no longer permitted.</li><li>▪ If the base volume has changed.</li><li>▪ If the Terminate command is issued.</li><li>▪ If the 4-way valve raises Move Fail or Leak alarms.</li></ul>

Run Stage	Description
<b>10</b>	<p><b>Wait Switch 1 Hit (Forward Run)</b></p> <p>Estimate time for switch 1 hit based on stream flowrate and pre switch 1 volume. A flow uncertainty value of 1.5 is also used in the calculation of travel time (Travel time = ((Pre-Switch 1 Volume * 3600) / Flow Rate) * Flow Uncertainty). Set switch timer running based on this estimate. (Setting this switch to 0 disables the timer and enters permanent wait state.) Proceed to next stage when switch 1 is hit.</p> <p>Abort:</p> <ul style="list-style-type: none"> <li>▪ If the prove is no longer permitted.</li> <li>▪ If the base volume has changed.</li> <li>▪ If the Terminate command is issued.</li> <li>▪ If the 4-way valve raises Move Fail or Leak alarms.</li> <li>▪ If pulse lock is lost.</li> <li>▪ If switch timer expires.</li> <li>▪ If switch sequence error.</li> </ul>
<b>11</b>	<p><b>Wait Switch 2 Hit (Forward Run)</b></p> <p>Estimate time for switch 2 hit based on stream flowrate and selected base volume. A flow uncertainty value of 1.5 is also used in the calculation of travel time (Travel time = ((Base Volume * 3600) / Flow Rate) * Flow Uncertainty). Set switch timer running based on this estimate. (Setting this switch to 0 disables the timer and enters permanent wait state.) Average meter and prover data whilst the sphere is between detectors. Perform stability checks whilst the sphere is between detectors. Proceed to next stage when switch 2 is hit.</p> <p>Abort:</p> <ul style="list-style-type: none"> <li>▪ If the prove is no longer permitted.</li> <li>▪ If the base volume has changed.</li> <li>▪ If the Terminate command is issued.</li> <li>▪ If the 4-way valve raises Move Fail or Leak alarms.</li> <li>▪ If pulse lock is lost.</li> <li>▪ If stability checks fail.</li> <li>▪ If switch timer expires.</li> <li>▪ If switch sequence error.</li> </ul>
<b>12</b>	<p><b>Perform Half Run Calculations</b></p> <p>No action; proceed to next stage.</p>
<b>13</b>	<p><b>Delay For Turn Around</b></p> <p>Set timer running to allow sphere to reach the chamber (having passed the sphere switch). Proceed to next stage when timer expires.</p> <p>Abort:</p> <ul style="list-style-type: none"> <li>▪ If the prove is no longer permitted.</li> <li>▪ If the base volume has changed.</li> <li>▪ If the Terminate command is issued.</li> </ul>
<b>14</b>	<p><b>Drive 4-Way Valve To Reverse</b></p> <p>Issue command to reset the prover hardware. Issue hardware command to drive the 4-way valve to reverse then wait for the valve to travel to the reverse position. Proceed to next stage upon reaching reverse.</p> <p>Abort:</p> <ul style="list-style-type: none"> <li>▪ If the prove is no longer permitted.</li> <li>▪ If the base volume has changed.</li> <li>▪ If the Terminate command is issued.</li> <li>▪ If the 4-way valve raises Move Fail or Leak alarms.</li> </ul>



Run Stage	Description
15	<p><b>Wait Switch 2 Hit (Reverse Run)</b></p> <p>Estimate time for switch 2 hit based on stream flowrate and pre switch 2 volume. A flow uncertainty value of 1.5 is also used in the calculation of travel time (Travel time = ((Pre-Switch 2 Volume * 3600) / Flow Rate) * Flow Uncertainty). Set switch timer running based on this estimate. Proceed to next stage when switch 2 is hit. Abort:</p> <ul style="list-style-type: none"> <li>▪ If the prove is no longer permitted.</li> <li>▪ If the base volume has changed.</li> <li>▪ If the Terminate command is issued.</li> <li>▪ If the 4-way valve raises Move Fail or Leak alarms.</li> <li>▪ If pulse lock is lost.</li> <li>▪ If switch timer expires.</li> <li>▪ If switch sequence error.</li> </ul>
16	<p><b>Wait Switch 1 Hit (Reverse Run)</b></p> <p>Estimate time for switch 1 hit based on stream flowrate and selected base volume. A flow uncertainty value of 1.5 is also used in the calculation of travel time (Travel time = ((Base Volume * 3600) / Flow Rate) * Flow Uncertainty). Set switch timer running based on this estimate. Average meter and prover data whilst the sphere is between detectors. Perform stability checks whilst the sphere is between detectors. Proceed to next stage when switch 1 is hit. Abort:</p> <ul style="list-style-type: none"> <li>▪ If the prove is no longer permitted.</li> <li>▪ If the base volume has changed.</li> <li>▪ If the Terminate command is issued.</li> <li>▪ If the 4-way valve raises Move Fail or Leak alarms.</li> <li>▪ If pulse lock is lost.</li> <li>▪ If stability checks fail.</li> <li>▪ If switch timer expires.</li> <li>▪ If switch sequence error.</li> </ul>
17	<p><b>Perform Full Run Calculations</b></p> <p>Based on forward and reverse run pulse counts, flight times and data averaged during the forward and reverse run. Proceed to next stage if calculations are all valid. Abort if there is a calculation failure (such as K-factor out of range).</p>
18	<p><b>Perform Run Average Calculations</b></p> <p>Average the individual run data over the last <math>n</math> good runs and place the data in the 12<sup>th</sup> slot of the run arrays. Proceed to the next stage.</p>
19	<p><b>Perform Repeatability Checks</b></p> <p>If the required number of runs <b>has not</b> been performed then proceed to next stage. If the required number of runs <b>has been</b> performed then check each of the last <math>n</math> run's K-factor against the average. If each K-factor is <b>within</b> tolerance then proceed to stage 21 (Await Reprove/Terminate). If any K-factors are <b>outside</b> tolerance and the maximum number of runs has been exceeded then proceed to stage 21 (Await Reprove/Terminate) otherwise proceed to the next stage.</p>

Run Stage	Description
<b>20</b>	<p><b>Delay For Turn Around (Then Go To Stage 9)</b></p> <p>Set timer running to allow sphere to reach the chamber (having passed the sphere switch).                      Proceed to next stage when timer expires.                      Abort if the Terminate command is issued.</p>
<b>21</b>	<p><b>Halted: Final - Await Terminate/Reprove Command</b></p> <p>End of prove. If:</p> <ul style="list-style-type: none"> <li>▪ Run control command is Initialise, proceed to stage 1 (Initialise Run Data).</li> <li>▪ Run control command is Terminate, proceed to stage 0 (Idle).</li> <li>▪ Run control command is Seat Sphere, proceed to the next stage (Seat Sphere) stage.</li> </ul>
<b>22</b>	<p><b>Seat The Sphere (Drive 4-Way Valve To Reverse)</b></p> <p>Issue hardware command to drive 4-way valve to reverse then wait for valve to travel to reverse.                      Proceed to next stage upon reaching reverse, by default the idle stage.                      Abort:</p> <ul style="list-style-type: none"> <li>▪ If the Terminate command is issued.</li> <li>▪ If the 4-way valve raises the Move Fail or Leak alarms.</li> </ul>
<b>23</b>	<p><b>Bi-directional Half Run Complete</b></p> <p>Extract the forward run pulse count and flight time ready for calculations.                      Proceed to the next stage.</p>
<b>24</b>	<p><b>Uni-Directional Full Run Calculations</b></p> <p>Based on forward run pulse counts, flight times and data averaged during the forward run.                      Proceed to next stage if calculations are all valid.                      Abort if there is a calculation failure (such as K-factor out of range).</p>
<b>25</b>	<p><b>Perform Final Average Calculations</b></p> <p>Calculate the final (average) K-factor and meter factor.                      Proceed to the next stage.</p>
<b>26</b>	<p><b>Check Runs Exceeded</b></p> <p>Check the number of runs executed against the maximum allowed.                      Proceed to the next stage.                      Abort if the maximum runs have been exceeded.</p>

Run Stage	Description
<b>27</b>	<p><b>Perform Meter Factor Deviation Checks</b></p> <p>Perform tolerance tests (calculated meter factor versus initial base meter factor: maximum deviation of 0.25% and calculated meter factor versus average of saved historical meter factors: maximum deviation of 0.1%).</p> <p>Only valid meter factors at normal flow rate are incorporated in the historical database. When the limit from either test is exceeded, the meter fact is not used for measurement and the corresponding meter factor at normal meter flow rate is not entered in the historical database. Proving reports are annotated as "ABORTED" with cause of failure stated.</p> <p>Proceed to stage 26 if any of the tolerance test fail. Proceed to the next stage.</p> <p><b>Note:</b> This stage is performed <b>only</b> if you configure the meter normal flow rate to a value greater than zero (<b>Aramco-style linearisation</b>) and you select "Product Table with History" when you create your configuration.</p>
<b>28</b>	<p><b>Await for Current Prove to be Rejected</b></p> <p>You can reject the current prove results within a predefined time-out.</p> <p>Print report when timer expires Abort if the prove is rejected. Proceed to the next stage.</p> <p><b>Note:</b> This stage is performed <b>only</b> if you configure the meter normal flow to a value greater than zero (<b>Aramco-style linearisation</b>).</p>

### B.1.7.2 Run Stage Abort Index

Following an abort the program displays a value in the Run Control abort index display.

*Table B-11. Run Stage Abort Index*

Value	Display	Description
0	NULL	Not used
1	OPERATOR	Operator abort
2	4WAY FAIL	4-way valve command timeout
3	SW1 TIMEOUT	Switch 1 timeout (the switch was not hit within the predicted time). To resolve, check wiring; set pre-switch volume to 0; or check that raw pulse bus frequency is greater than 0.
4	SW2 TIMEOUT	Switch 2 timeout (the switch was not hit within the predicted time). To resolve, check wiring; set pre-switch volume to 0; or check that raw pulse bus frequency is greater than 0. <b>Note:</b> If the flow computer does not see SW2, check the raw pulse bus.
5	STAB WAIT	Temperature/Pressure/Flowrate wait stability timeout
6	STAB HOLD	Temperature/Pressure/Flowrate hold stability timeout
7	AVG CALC	Average calculation error; number of samples exceeds 30,000
8	HALF CALC	Not used
9	FULL CALC	Error occurred when performing full run calculations (for details refer to <i>Run Stage Calculation Index</i> ).

Value	Display	Description
10	RUNS EXCEEDED	Maximum number of runs exceeded
11	SS ERROR	Sphere switch sequence error
12	PLS LOCK LOST	Pulse interpolator module lock lost
13	IO FAIL	I/O module failed to respond to prove request
14	NULL	Not used
15	BVOL CHANGED	Base volume changed
16	KF/MF RANGE	K-factor or meter factor out of range, even if alarms not configured. To resolve, check the high and low limits for the meter factor, the K-factor, and pulse count objects.
17	4WAY MOVED	4-way valve moved unexpectedly; pulse count range checked.
18	UNAVAIL	Prover unavailable
19	NULL	Not used
20	INV CALC	Unsupported volume/mass calculations
21	MF DEV INVALID	Failed during meter factor deviation checks.

### B.1.7.3 Run Stage Calculation Index

If a prover calculation fails, the program displays a value indicating the failed calculation in the Run Stage Calc Index display.

*Table B-12. Run Stage Calculation Index*

Value	Display	Description
0	IDLE	No calculation errors
1	CTSP	The calculation to determine the correction factor for the effect of temperature on the steel at the prover (CTSp) failed because the CTSp value is less than 0.5 or greater than 1.5.
2	CPSP	The calculation to determine the correction factor for the effect of pressure on the steel at the prover (CPSp) failed because the modulus of elasticity or wall thickness is 0 and the CPSp value is less than 0.5 or greater than 1.5.
3	N/A	Not used
4	N/A	Not used
5	CPLP	The calculation to determine the correction factor for the effect of pressure on the liquid at the prover (CPLp) failed because of low density.
6	CPLM	The calculation to determine the correction factor for the effect of pressure on the liquid at the meter (CPLm) failed because of low density
7	N/A	Not used
8	CTLP	The calculation to determine the correction factor of the effect of temperature on the liquid at the prover (CTLp) failed because of low density.
9	CTLM	The calculation to determine the correction factor of the effect of temperature on the liquid at the meter (CTLm) because of low density
10	PRV VOL	The calculation to determine the gross standard volume of the prover (GSVp) failed because no error checks occurred.
11	MCF	The calculation to determine the meter correction factor (MCF) failed because the CTLm or CPLm values are less than or equal to 0.
12	K-FACTOR	K-factor calculation is outside the low/high alarm limits
13	METER FACTOR	Meter factor calculation is outside the low/high alarm limits
14	PRV MASS	Prover mass calculation failed because the prover gross volume or density is less than or equal to 0
15	MTR MASS	Mass K- factor calculation failed because the pulses or prover mass

Value	Display	Description
		is less than or equal to 0
16	IND MTR VOL	Calculation to determine the indicated volume at the meter (IVm) failed because pulses or base K-factor is less than or equal to 0

### B.1.8 Prove/Stream Data

The prover computer reads the following data from the stream under prove:

- Stream Temperature (in use)
- Stream Pressure (in use)
- Stream Standard Density (in use)
- Alpha Constant K0
- Alpha Constant K1
- Alpha Constant K2
- Equilibrium Vapour Pressure
- Meter Factor (in use)
- K-factor (in use)
- CTSm (in use)
- CPSm (in use)
- Flowrate Minimum
- Flowrate Maximum
- FCV Setpoint
- FCV Output
- Reference Temperature
- Meter Density (in use)
- FCV Auto/Manual Status
- FCV Tracking Status
- Volume Correction Rounding Status
- Volume Correction Units Selection
- Volume Correction Product Type
- Volume Correction CPL Option
- Volume Correction Product Subtype
- Volume Correction Density Type
- K-factor Units
- Normal Meter Flow Rate
- Initial Base Meter Factor
- Initial Base Meter Factor Time Stamp
- Base Meter Factor Linearisation Points
- Historical Meter Factors
- Historical Meter Factors Time Stamp

If the prove completes successfully, the system transfers the following prove data to the stream but does not use it until you accept the data at the stream.

- Proved K-factor
- Proved Meter Factor
- Proved Turbine Frequency
- Proved Flowrate
- Proved Meter Temperature
- Proved Meter Pressure
- Historical Meter Factors
- Historical Meter Factors Time Stamp
- Proved Meter Factor Acceptance Flag

### B.1.9 Prove Reports

The system provides two reports, volume or mass K-factor. Which report generates is determined by the K-factor units, pulses/volume, or pulses/mass.

Following are two customized proof reports:

```
=====
1                               METER PROOF REPORT                               06/08/2013  09:58:40
=====
```

```
STREAM ON PROOF      : 0
PROVING RATE        :          0.000 m3/h

STANDARD DENSITY    :          0.000 kg/m3
BASE VOLUME        :          0.000 m3
STREAM TEMPERATURE :          0.000 Deg.C      STREAM PRESSURE : 0.000 barg
PROVER TEMP        :          0.000 Deg.C      PROVER PRESS   : 0.000 barg
```

TRIAL NO.	TEMP (Deg.C)	STREAM PRESSURE (barg)	PROVER TEMP (Deg.C)	PROVER PRESSURE (barg)	STANDARD DENSITY (kg/m3)	PULSES ( )	METER FLOWRATE (m3/h)	K-FACTOR (pls/m3)
1	0.00	0.00	0.00	0.00	0.000	0.0	0.0	0.0
2	0.00	0.00	0.00	0.00	0.000	0.0	0.0	0.0
3	0.00	0.00	0.00	0.00	0.000	0.0	0.0	0.0
4	0.00	0.00	0.00	0.00	0.000	0.0	0.0	0.0
5	0.00	0.00	0.00	0.00	0.000	0.0	0.0	0.0
6	0.00	0.00	0.00	0.00	0.000	0.0	0.0	0.0
7	0.00	0.00	0.00	0.00	0.000	0.0	0.0	0.0
8	0.00	0.00	0.00	0.00	0.000	0.0	0.0	0.0
9	0.00	0.00	0.00	0.00	0.000	0.0	0.0	0.0
10	0.00	0.00	0.00	0.00	0.000	0.0	0.0	0.0
11	0.00	0.00	0.00	0.00	0.000	0.0	0.0	0.0
12	0.00	0.00	0.00	0.00	0.000	0.0	0.0	0.0
AVE	0.00	0.00	0.00	0.00	0.000	0.0	0.0	0.0

	CTLM	CPLM	CTSP	CPSP	CTLP	CPLP	FTIME
1	0.000000	0.000000	0.000000	0.000000	0.000000	0.000000	0.000000
2	0.000000	0.000000	0.000000	0.000000	0.000000	0.000000	0.000000
3	0.000000	0.000000	0.000000	0.000000	0.000000	0.000000	0.000000
4	0.000000	0.000000	0.000000	0.000000	0.000000	0.000000	0.000000
5	0.000000	0.000000	0.000000	0.000000	0.000000	0.000000	0.000000
6	0.000000	0.000000	0.000000	0.000000	0.000000	0.000000	0.000000
7	0.000000	0.000000	0.000000	0.000000	0.000000	0.000000	0.000000
8	0.000000	0.000000	0.000000	0.000000	0.000000	0.000000	0.000000
9	0.000000	0.000000	0.000000	0.000000	0.000000	0.000000	0.000000
10	0.000000	0.000000	0.000000	0.000000	0.000000	0.000000	0.000000
11	0.000000	0.000000	0.000000	0.000000	0.000000	0.000000	0.000000
12	0.000000	0.000000	0.000000	0.000000	0.000000	0.000000	0.000000
AVE	0.000000	0.000000	0.000000	0.000000	0.000000	0.000000	0.000000

CURRENT K-FACTOR : 0.00 pls/m3  
 NEW K-FACTOR : 0.00 pls/m3  
 NEW METER FACTOR : 0.000000  
 REPEATABILITY : 0.000000 %

2 PROVING REPORT  
 Emerson Process Management

LOCATION : AAAAAAA DATE/TIME : MM/DD/YYYY HH:MM:SS

METER MANUFACTURER: AAAAAAA PROVER MANUFACTURER: AAAAAAA  
 METER MODEL: AAAAAAA PROVER SERIAL NUMBER: AAAAAAA  
 METER SERIAL NUMBER: AAAAAAA  
 METER SIZE (mm): 0.000  
 NOMINAL K-FACTOR: 0.000  
 METER TAG NUMBER: AAAAAAA

PRIMARY FLOW COMPUTER: XX:XX:XX:XX:XX:XX  
 LIQUID: A CRUDE  
 OBSERVED DENSITY: 0.000 kg/m3 AT 0.00 Deg.C = 0.000 kg/m3 AT 0.000 Deg.C

TRIAL NO.	PULSES TOTAL	TOTAL TIME S	PRESS PROVER barg	METER barg	TEMP PROVER Deg.C	METER Deg.C	TRIAL M.F. MFT
1	0.00	0.00	0.00	0.00	0.000	0.0	0.0
2	0.00	0.00	0.00	0.00	0.000	0.0	0.0
3	0.00	0.00	0.00	0.00	0.000	0.0	0.0
4	0.00	0.00	0.00	0.00	0.000	0.0	0.0
5	0.00	0.00	0.00	0.00	0.000	0.0	0.0
6	0.00	0.00	0.00	0.00	0.000	0.0	0.0
7	0.00	0.00	0.00	0.00	0.000	0.0	0.0
8	0.00	0.00	0.00	0.00	0.000	0.0	0.0
9	0.00	0.00	0.00	0.00	0.000	0.0	0.0
10	0.00	0.00	0.00	0.00	0.000	0.0	0.0
AVE	0.0	0.0	0.0	0.0	0.000	0.	0.

REPEATABILITY FOR LAST 10 TRIALS = 0.000 %

- A. TEMP. CORRECTION FACTOR FOR LIQUID IN PROVER (CTLp) 0.000
- B. PRESS. CORRECTION FACTOR FOR LIQUID IN PROVER (CPLp) 0.000
- C. COMBINED CORRECTION FACTOR FOR PROVER (CCFp) 0.000
- D. GROSS STANDARD VOLUME FOR PROVER (GSVp) 0.000 Sm3
- E. INDICATED METER VOLUME (IVm) 0.000 m3
- F. TEMP. CORRECTION FACTOR FOR LIQUID IN METER (CTLm) 0.000
- G. PRESS. CORRECTION FACTOR FOR LIQUID IN METER (CPLm) 0.000
- H. COMBINED CORRECTION FACTOR FOR METER (CCFm) 0.000
- I. GROSS STANDARD VOLUME FOR METER (GSVm) 0.000 Sm3
- J. AVG. METER FLOW RATE 0.000 m3/h
- K. METER FACTOR @ PROVING FLOW RATE 0.000
- L. METER FACTOR @ NORMAL METER FLOW RATE OF 0.000 m3/h 0.000  
 METER FACTOR TEST RESULTS (%): 1) 0.00 2) 0.00
- M. PROVER MASS 0.000 tonne
- N. METER MASS 0.000 tonne

HISTORICAL DATA OF METER FACTORS @ NORMAL METER FLOW RATE OF 0.000 m3/h  
 INITIAL BASE METER FACTOR (DATE: MM/DD/YY) = 0.000

DATE:	MM/DD/YY	MM/DD/YY	MM/DD/YY	MM/DD/YY	MM/DD/YY
FACTOR:	0.000	0.000	0.000	0.000	0.000
DEVIATION(±):	0.00%	0.00%	0.00%	0.00%	0.00%

DATE:	MM/DD/YY	MM/DD/YY	MM/DD/YY	MM/DD/YY	MM/DD/YY
FACTOR:	0.000	0.000	0.000	0.000	0.000
DEVIATION(±):	0.00%	0.00%	0.00%	0.00%	0.00%

PROVED FOR: \_\_\_\_\_ BY : \_\_\_\_\_ DATE: \_\_\_\_\_

WITNESSED BY : \_\_\_\_\_ DATE: \_\_\_\_\_

## B.1.10 Proving Calculations

This section provides information on calculations used in the prove procedure.

The calculations are for volume or mass K-factor and the choice is determined by the K-factor units, pulses/volume or pulses/mass.

**Average Method** The "average method" option directs how the system performs the final averaging:

- The Meter Factor option calculates a meter factor for each run and takes the average of these to arrive at the final meter factor.
- The K-factor option calculates a K-factor for each run and takes the average of these to arrive at the final K-factor.
- The Pulses option takes the average of the pulses, temperature, pressure, and other variables and performs a final set of calculations using this average data to arrive at the final meter and K-factor.

The Meter Factor and K-factor options are equivalent to the 'average meter factor' method used for API Ch.12 Section 2 Part 3 Proving reports. The Pulses option is equivalent to the 'average data' method.

**Standard References** The prover volume correction calculations correspond to those used by the meter under prove, in which the system transfers the calculation steering variables from the stream.

Name	Standard Reference
Averaging Calcs	General mathematic principles
Stability Calcs	General mathematic principles
Correction Factor (CTLm/CTLp)	Corresponds to meter calculations
Correction Factor (CPLm/CPLp)	Corresponds to meter calculations
Correction Factor (CTSp/CPSp)	API Ch 12
K-factor/Flowrate	API Ch 12
K-factor Deviation	API Ch 4
K-factor Deviatoin Statistical Method	NORSOK I-105 Annex F
Meter Factor	API Ch 12

### B.1.10.1 Formulae: Averaging Calculations

#### Run Average Data

$$X_{run} = \frac{\sum X_{inst}}{Samples}$$

where:

- $X_{run}$  is the average value of the variable for a single run
- $X_{inst}$  is the instantaneous sample value of the variable being averaged
- $Samples$  is the number of samples taken during the run

The sampled variables ( $X_{inst}$ ) are:

- Prover temperature (average of inlet and outlet)



- Prover pressure (average of inlet and outlet)
- Meter temperature
- Meter pressure
- Standard density

### Run Average Frequency (Hz)

$$FREQ_{run} = \frac{PC}{\Delta t}$$

where:

$FREQ_{run}$  is the average meter frequency for a single run  
 $PC$  is the run pulse count  
 $\Delta t$  is the run flight time (secs)

### Final Average Data (Over Consecutive Good Runs)

$$X_{final} = \frac{\sum X_{run}}{N}$$

where:

$X_{final}$  the final average value of a relevant variable for the  $N$  consecutive good runs  
 $X_{run}$  the value of the variable for a single run  
 $N$  the number of consecutive good runs

The final average variables are:

- Pulse count
- Flight time
- Prover temperature (average of inlet and outlet)
- Prover pressure (average of inlet and outlet)
- Meter temperature
- Meter pressure
- Vapour pressure
- Standard density
- Prover density
- Meter density
- Meter frequency
- Prover flowrate
- Alpha
- Prover beta
- Meter beta
- CTSm
- CPSm
- CTLm
- CPLm
- CTSp
- CPSp
- CTLp
- CPLp
- Prover standard volume
- Prover mass

- Meter mass
- K-factor
- Meter factor

### B.1.10.2 Formulae: Stability Calculations

#### Stream/Prover Discrepancy Checks

$$X_{diff} = X_A - X_B$$

where:

$X_A, X_B$  are the variables being compared

The variables compared are:

- Prover Inlet - Prover Outlet (Temperature and Pressure)
- Prover Inlet - Meter (Temperature and Pressure)
- Prover Outlet - Meter (Temperature and Pressure)

#### Variable Rate of Change

$$X_{rate} = \frac{X_{new} - X_{old}}{Period}$$

where:

$X_{rate}$  the rate of the variable

$X_{new}$  the new sample value

$X_{old}$  the previous sample value

$Period$  the sampling interval

The variables compared are:

- Prover Inlet (Temperature and Pressure)
- Prover Outlet (Temperature and Pressure)
- Meter Flowrate

### B.1.10.3 Formulae: Correction Factor (CTLm/CTLp)

#### Correction Factor for the Effect of Temperature on the Liquid

These factors are calculated according to the product, using the same calculations as the meter under prove.

### B.1.10.4 Formulae: Correction Factor (CPLm/CPLp)

#### Correction Factor for the Effect of Pressure on the Liquid

These factors are calculated according to the product, using the same calculations as the meter under prove.

### B.1.10.5 Formulae: Correction Factor (CTSp/CPSp)

#### Correction Factor for the Effect of Temperature on the Prover Steel

$$CTSp = 1 + [(T - T_b) G_c]$$

where:

$G_c$	Mean coefficient of cubical expansion per degree temperature of the material of which the container is made between $T_b$ and $T$ .
$T_b$	Base temperature.
$T$	Average liquid temperature in the container.

### Correction Factor for the Effect of Pressure on the Prover Steel

$$CPSp = 1 + (P_p - P_b) D/Et$$

where:

$P_p$	Pressure of the liquid at the prover (barg)
$P_b$	Base Pressure (barg)
$D$	Inside diameter of the flow tube (mm)
$E$	Modulus of elasticity of the flow tube steel (bar)
$t$	Wall thickness of the prover flow tube (mm)

---

**Note:** The average  $T_p$ ,  $P_p$  over the run is used for calculating the correction factors.

---

## B.1.10.6 Formulae: Volume Prover Calculations

### Prover Gross Standard Volume (Sm<sup>3</sup>)

$$GSVP_{run} = BV \times CTLp_{run} \times CPLp_{run} \times CTSp_{run} \times CPSp_{run}$$

where:

$BV$	is the entered volume for the prover at standard conditions
$CTLp_{run}$	is the correction factor for the effect of temperature on the liquid at the prover, using the average prover run temperature
$CPLp_{run}$	is the correction factor for the effect of pressure on the liquid at the prover, using the average prover run pressure
$CTSp_{run}$	is the correction factor for the effect of temperature on the steel at the prover, using the average prover run temperature
$CPSp_{run}$	is the correction factor for the effect of pressure on the steel at the prover, using the average prover run pressure

### Meter Indicated Volume (m<sup>3</sup>)

$$IVm_{run} = \frac{PC_{run}}{KFm_{run}}$$

where:

$PC_{run}$	is the run pulse count (pls)
$KFm$	is the meter K-factor (pls/m <sup>3</sup> )

### Meter Indicated Standard Volume (Sm<sup>3</sup>)

$$ISVm_{run} = IVm_{run} \times CTLM_{run} \times CPLM_{run}$$

where:

$IVm_{run}$  is the indicated volume for the meter

$CTLM_{run}$  is the correction factor for the effect of temperature on the liquid at the meter, using the average meter run temperature

$CPLM_{run}$  is the correction factor for the effect of pressure on the liquid at the meter, using the average meter run pressure

### Volume K-factor (pls/m3)

$$KFM_{run} = \frac{PC_{run} \times CTLM_{run} \times CPLM_{run}}{GSVP_{run}}$$

where:

$PC_{run}$  is the run pulse count (pls)

$CTLM_{run}$  is the correction factor for the effect of temperature on the liquid at the meter, using the average meter run temperature

$CPLM_{run}$  is the correction factor for the effect of pressure on the liquid at the meter, using the average meter run pressure

$GSVP_{run}$  is the prover gross standard volume (m<sup>3</sup>)

### Meter Factor

$$MF = \frac{GSVP_{run}}{ISVm_{run}}$$

where:

$GSVP_{run}$  is the prover gross standard volume (m<sup>3</sup>)

$ISVm_{run}$  is the meter indicated standard volume (m<sup>3</sup>)

### Prover Volume Flowrate (m3/h)

$$VFRP_{run} = \frac{GSVP_{run}}{\Delta t \times CTLM_{run} \times CPLM_{run}} \times 3600$$

where:

$GSVP$  is the prover gross standard volume (m<sup>3</sup>)

$CTLM_{run}$  is the correction factor for the effect of temperature on the liquid at the meter, using the average meter run temperature

$CPLM_{run}$  is the correction factor for the effect of pressure on the liquid at the meter, using the average meter run pressure

$\Delta t$  is the run flight time (s)

## B.1.10.7 Formulae: Mass Prover Calculations

### Prover Gross Volume (m3)

$$GVp_{run} = BV \times CTSp_{run} \times CPSp_{run}$$

where:

$BV$  is the entered volume for the prover at standard conditions

$CTSp_{run}$  is the correction factor for the effect of temperature on the steel at the prover, using the average prover run temperature

$CPSp_{run}$  is the correction factor for the effect of pressure on the steel at the prover, using the average prover run pressure

### Prover Mass (kg)

$$Mp_{run} = GVp_{run} \times \text{Density}$$

where:

$GVp_{run}$  is the prover gross volume (m<sup>3</sup>)

$Density$  is the density at prover conditions (kg/m<sup>3</sup>)

### Meter Mass (kg)

$$Mm_{run} = \frac{PC_{run}}{Kfm_{run}}$$

where:

$PC_{run}$  is the run pulse count (pls)

$Kfm_{run}$  is the meter K-factor (pls/kg)

### Meter Factor

$$MF = \frac{Mp_{run}}{Mm_{run}}$$

where:

$Mp_{run}$  is the prover mass (kg)

$Mm_{run}$  is the meter mass (kg)

### Mass K-factor (pls/kg)

$$Kfm_{run} = \frac{PC_{run}}{Mp_{run}}$$

where:

$PC_{run}$  is the run pulse count (pls)

$Mp_{run}$  is the prover mass (kg)

### Prover Mass Flowrate (kg/h)

$$MFRp_{run} = \frac{Mp_{run}}{\Delta t} \times 3600$$

where:

$Mp_{run}$  is the mass for the master meter (kg)

$\Delta t$  is the run flight time (s)

### B.1.10.8 K-factor Deviation

When the required number of consecutive good runs has been achieved, the program checks each individual run (which make up the  $N$  consecutive good runs) to see how far it deviates from the average. If any run's K-factor deviates by more than the allowable limit then additional runs are performed and the test is repeated.

When all the required run K-factors fall within the deviation limit, then the prove is considered successful and Final average data is calculated. At the same time the program stores the single maximum deviation value (repeatability) of the good run K-factors as an indication of how well the prove fell within the deviation tolerance.

#### API Ch.4 Method 1 (default)

$$K_{dev} = \frac{(K_{avg} - K_{run})}{K_{avg}} \times 100$$

#### MX-MN/AVG

$$K_{dev} = \frac{(K_{max} - K_{min})}{K_{avg}} \times 100$$

#### MX-MN/MX+MN2

$$K_{dev} = \frac{(K_{max} - K_{min})}{(K_{max} + K_{min}) \div 2} \times 100$$

#### MX-MN/MN

$$K_{dev} = \frac{(K_{max} - K_{min})}{K_{min}} \times 100$$

#### MX-MN/MX\*MN

$$K_{dev} = \frac{(K_{max} - K_{min})}{(K_{max} \times K_{min})} \times 100$$

#### MX-AV/AV

$$K_{dev} = \frac{(K_{max} - K_{avg})}{K_{avg}} \times 100$$

#### AV-MN/AV

$$K_{dev} = \frac{(K_{avg} - K_{min})}{K_{avg}} \times 100$$

where:

$K_{dev}$  is the K-factor deviation (%)

$K_{avg}$  is the average K-factor of  $N$  consecutive good runs (pls/m<sup>3</sup>)

- $K_{min}$  is the minimum K-factor of  $N$  consecutive good runs (pls/m<sup>3</sup>)
- $K_{max}$  is the maximum K-factor of  $N$  consecutive good runs (pls/m<sup>3</sup>)
- $K_{run}$  is the run K-factor being checked (pls/m<sup>3</sup>)

**Statistical**

$$K_{dev} = 200 \times t_{N-1} \times \frac{S_{N-1}}{K_{avg} \times \sqrt{N}}$$

where:

- $K_{dev}$  is the K-factor deviation (%)
- $K_{avg}$  is the average K-factor of  $N$  consecutive good runs (pls/m<sup>3</sup>)
- $t_{N-1}$  is the uncertainty band confidence level, which is a selectable value (95%, 99%, 99.5%, or a user-defined value). NORSOK requires this method (using the student-t distribution) at a recommended value of 95%. API MPMS Ch.4.8 also recommends 95%.
- $S_{N-1}$  is the standard deviation of K-factor of  $N$  consecutive good runs (pls/m<sup>3</sup>)

**B.1.10.9 Meter Factor Deviation Tests**

This section defines the Meter Factor Deviation tests.

**Calculated Meter Factor versus Initial Base Meter Factor)**

$$\% \text{ Deviation Test 1} = \frac{(\text{MFCP}_{FRN} - \text{Initial Base Meter Factor})}{(\text{Initial Based Meter Factor})} \times 100$$

where:

$\text{MFCP}_{FRN}$  is the calculated meter factor from current prove at normal flow rate.

Maximum deviation of  $\pm 0.25$  %.

**Calculated Meter Factor versus Average of Previous Historical Meter Factors)**

$$\% \text{ Deviation Test 2} = \frac{(\text{MFCP}_{FRN} - \text{Average of Previous Meter Factors})}{(\text{Average of Previous Meter Factors})} \times 100$$

where:

$\text{MFCP}_{FRN}$  is the calculated meter factor from current prove at normal flow rate.

Maximum deviation of  $\pm 0.1$  %.

## B.2 Compact Prover – Liquid Only

Two components enable you to control the prove:

- **Prove sequence**, a station-based function which sets up the prove environment, and
- **Run control**, a prover-based function which drives the prover hardware, counts pulses, and performs the K-factor calculations.

Following a successful prove, the system verifies the stream normal flow rate value:

- If the normal flow rate is set to a value greater than zero (**Aramco-style linearisation**), the run control waits for a predefined amount of time for you to reject the current prove results. If a prove is rejected, the proving report is annotated as "ABORTED". If the time-out elapses, the prove sequence downloads the prove results to the stream being proved and the data is automatically used in the subsequent calculations.

If the normal flow rate is zero (**non-Aramco-style linearisation**), the prove sequence downloads the prove results to the stream being proved, but does not use the data until it is accepted either locally at the S600+ or via a supervisory computer.

When the prove runs complete, you can either re-run the prove or terminate, at which point (if so configured) the sequence restores the valves to their pre-prove state.

The compact prover has a small volume chamber so a proof run consists of repeated proof passes (a default of 5, a maximum of 39). The S600+ does not create a proof report, although you can add this option through a user stage. Contact Technical Support.

---

### Notes:

- The prove sequence downloads both a K-factor and a meter factor. Applications typically use the original K-factor from the meter calibration report and update the meter factor, which may be a fixed value or derived from a linearisation process. Alternatively, the meter factor can remain unchanged and the K-factor (fixed or linearised) updated.
- The meter factor deviation tests and the historical meter factor database are only supported for "local" streams (part of the same configuration with the prover), if you configure the stream normal flow rate to a value greater than zero and you select "Product Table with History" when you create your configuration.
- You define a ticket as Official or Unofficial when you configure a prove. This selection applies to both the Aramco-style and non-Aramco-style linearisation.

Following an **Official** prove, the prove sequence is determined by the Aramco / non-Aramco style linearisation selection.



Following the **Unofficial** prove, the prove sequence does not download the prove results to the stream being proved. This is typically used to determine an approximate K-Factor / Meter Factor before an official prove takes place or when maintenance activities are being performed on the site.

The Official/Unofficial selection displays in the report header.

## B.2.1 Inputs/Outputs

For compact proving, the S600+ requires the following hardware:

- A CPU module (P152+)
- An I/O module (P144)
- A Prover module (P154)

**Inputs** A compact prover normally has the following inputs:

Prover Inlet Pressure	4-20mA ADC
Prover Outlet Pressure	4-20mA ADC
Prover Plenum Pressure	4-20mA ADC
Prover Inlet Temperature	4-wire PRT
Prover Outlet Temperature	4-wire PRT
Stream Raw Pulses	Raw Pulse Input
Prove Enable Status	Digital Input
Prover Ready (Upstream) Status	Digital Input
Piston Detector Switch	Switch Input 1

**Note:** If there is only one pressure and temperature input, assign inlet and outlet objects to use the same input.

**Outputs** A compact prover normally has the following outputs:

Hydraulics On/Off	Digital Output
Prove Launch (Run) Command	Digital Output
Plenum Charge	Digital Output
Plenum Vent	Digital Output

You can regulate plenum pressure to lie within boundary limits by means of two digital outputs – a charge and vent system. The control logic is described in the Run Control stages.

## B.2.2 Communications

Using the Modbus protocol, a slave link provides communications with any remote stream flow computers.

- To set up the link at the prover (which is the master), select **Tech/Engineer > Communications > Assignment > Prover Master Lin > Seq Enable**.

- To set up the Modbus address, select **Tech/Engineer > Communications > Assignment > Prover Master Lin > Seq Addr.**

Prover/Stream Link	Default Setting
Modbus RTU Master Prover/Stream Link	Serial RS485 - Comm 5 9600 8 bits No Parity 1 stop bit Address = 1 (front panel)

- To set up the link at the stream (which is the slave), select **Tech/Engineer > Communications > Assignment > Next > Prover Slave Lin.**

---

**Note:** You can reset the ports, baud rate, number of bits, and parity values through the S600+'s front panel.

---

### B.2.3 Pulse Measurement

The primary function of the prover is to calculate an accurate K-factor value for the meter under prove. The compact prover does this by counting the number of pulses from the stream meter and equating them to the known volume of the prover.

The stream flow computer receives pulses from its meter and transmits a pulse train output ('Raw Pulse Output') which represents the number of pulses received, including bad pulse correction. The prove sequence commands the selected stream to turn on its Raw Pulse Output, which allows the prover computer to monitor the pulses from the meter. The prover counts pulses during a proof run, and corrects the count for temperature and pressure.

When the proof run completes, the prover calculates the stream's K-factor from the corrected pulse count and the known prover volume.

---

**Note:** The electrical diagram for the Prover module shows a Raw Pulse Output, but this is not available. You cannot use this Raw Pulse Output to pass pulses input to the Prover module to the Raw Pulse Input.

---

**Pulse Gating** When a proof pass is launched the flow drives a piston forward through the chamber, triggering a detector switch twice as it goes. Hydraulic pressure is then used to reverse the piston through the chamber ready for the next pass to commence.

For each pass the raw pulses are counted during the period between the detector switch triggers as the piston moves forward through the chamber.

**Pulse Interpolation** Pulse interpolation is used when the pulse count is low (typically less than 10,000 pulses per run).

The S600+ support two methods of pulse interpolation: dual chronometry (the standard) or a pulse interpolation module (optional). Either method allows the prover computer to resolve the pulse count to better than the API recommendation of 1 part in 10,000.

Dual chronometry adds accurate timing of the period between detectors so in effect partial pulses can be counted.

If you do not select dual chronometry, you can use a Pulse Interpolation Module (PIM) to achieve greater resolution. You enter an interpolation factor corresponding to the PIM setting into the prover S600+ using a keypad.

A pulse lock lost digital input is provided to indicate whether the PIM pulses are valid. The input is active when the PIM output is considered good.

### B.2.4 Proving Control Signal Timing

Figure B-7 is a timing diagram showing the sequence of relevant signals during the initial pass of a proof run. Table B-13 describes each stage of the diagram.

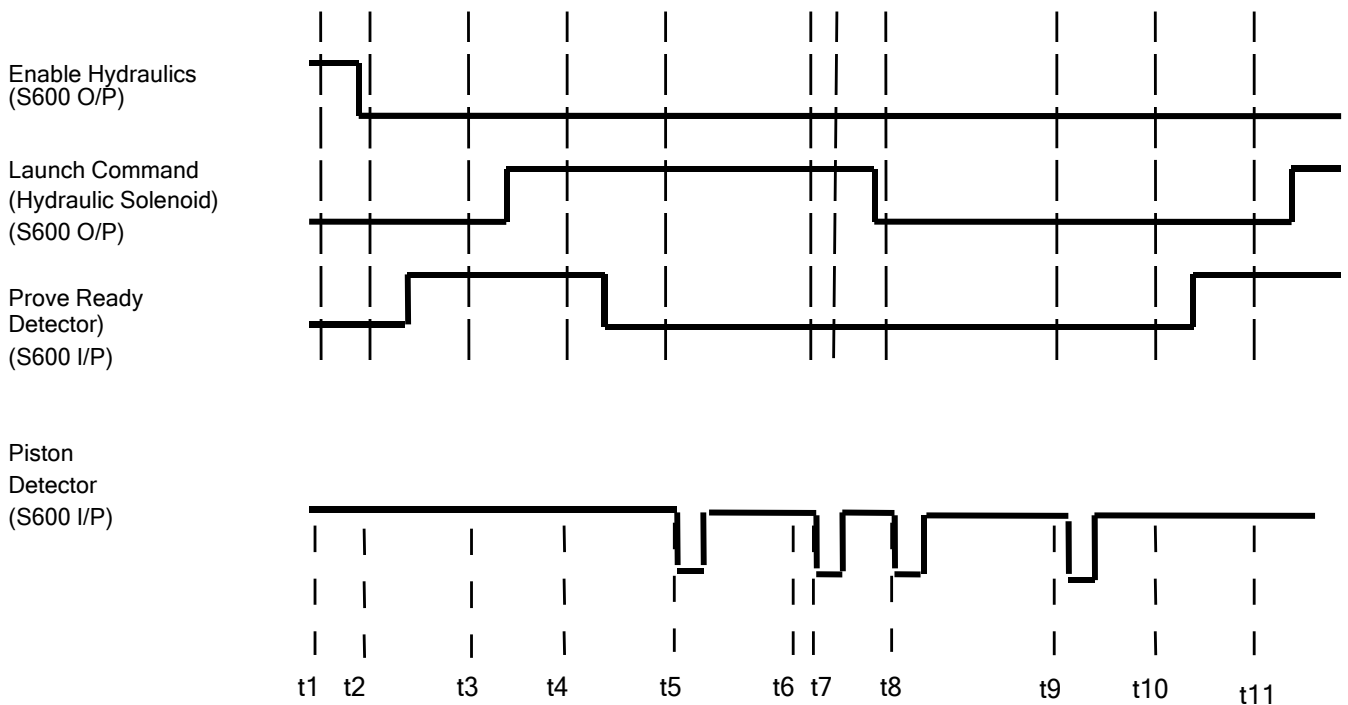

Figure B-7. Initial Pass of Proof Run Timing

Table B-13. Proof Run Signals

Pass	Description
------	-------------

Pass	Description
t1	At the start of a prove cycle there is no hydraulic pressure (the hydraulic pump is switched off) so if there is flow the piston is stationary downstream. The Enable Hydraulics signal (an S600+ digital output) is switched to start the hydraulic pumps. The Hydraulic Solenoid signal (an S600+ digital output) is high, closing the associated solenoid valve and returning the piston returns upstream due to the increased hydraulic pressure.
t2	The piston returns upstream and is held there by the hydraulic pressure. When the piston is upstream the upstream detector triggers, switching the associated Upstream Detector signal (an S600+ digital input) to high.
t3	A user-configurable time after t1 (providing that the Upstream Detector signal is switched to high), the piston launches, switching the Hydraulic Solenoid signal to low and opening the solenoid valve which reduces the hydraulic pressure. The Hydraulic Solenoid signal remains low until the Volume Detector switch has been triggered a <b>second</b> time.
t4	As the piston moves down the chamber it is no longer upstream and the Upstream Detector signal switches to low.
t5	The first volume piston detector switch triggers and the Volume Piston Detector signal (an S600+ digital input) produces a pulse, switching from high to low and back to high again.
t6	The second volume piston detector switch triggers and the Volume Piston Detector signal produces a second pulse, switching from high to low and back to high again.
t7	When it detects the second Volume Piston Detector signal pulse, the Hydraulic Solenoid signal switches to low to close the solenoid valve. This increases the hydraulic pressure and returns the piston upstream.
t8	The returning piston triggers the second volume piston detector switch, generating a third pulse on the Volume Piston Detector signal. <b>Note:</b> The piston moving down the chamber slowly (switching the Hydraulic Solenoid signal low on detection of the second Volume Piston Detector signal) could result in the piston starting to return <b>prior</b> to having fully cleared the second volume chamber detector switch. In that case, the two pulses which commenced at passes t6 and t8 may form a single pulse of longer duration.
t9	The first Volume Piston Detector switch triggers on the return of the piston, generating a fourth pulse on the Volume Piston Detector signal.
t10	The piston returns upstream and is held there by hydraulic pressure. When the piston is upstream the upstream detector triggers and switches the associated Upstream Detector signal to high.
t11	The piston launches for the second pass, switching the Hydraulic Solenoid signal to low, which opens the solenoid valve and reduces the hydraulic pressure. The prove cycle continues for the required number of passes. When the prove cycle completes the Enable Hydraulics switches to high to stop the hydraulic pumps.

## B.2.5 Prove Sequence and Control

Two components enable you to control the prove:

- **Prove sequence**, a station-based function which sets up the prove environment, and
- **Run control**, a prover-based function which drives the hardware, counts pulses, and performs the K-factor calculations.

The S600+'s front panel display provides the following commands you can use to control and monitor the two prove control tasks (**Operator > Station > Sequence Ctl**):

Display	Description
SEQ CTL	Operator commands for sequence control (outer loop).
SEQ STREAM NO.	Enter the designate stream number to be proved. <b>Note:</b> For local streams, this is the logical stream number. For remote streams, this is the slave number in the Modbus master map. For example, if the first slave has a Modbus address of 22, this is stream 1. If the second slave in the master map has an address of 33, this is stream 2.
SEQ STAGE INDEX	Shows current sequence stage as the sequence progresses.
SEQ STAGE PREV	Indicates the sequence stage immediately prior to the current stage. If an abort occurs, use this value to help identify the source of the abort.
SEQ ABORT INDEX	In the event of a sequence error, an abort reason index displays here.
RUN CTL	Operator commands for proof run (inner loop)
Run permit	Interlock required for starting proof run.
Run stage index	Shows current proof run stage as the sequence progresses.
Run abort index	In the event of a proof run sequence error, an abort reason index displays here.

Following a successful prove, the system verifies the stream normal flow rate value:

- If the normal flow rate is set to a value greater than zero (**Aramco-style linearisation**), the run control waits for a predefined amount of time for you to reject the current prove results. If a prove is rejected, the proving report is annotated as "ABORTED". If the time-out elapses, the prove sequence downloads the prove results to the stream being proved and the data is automatically used in the subsequent calculations.
- If the normal flow rate is zero (**non-Aramco-style linearisation**), the prove sequence downloads the prove results to the stream being proved, but does not use the data until it is accepted either locally at the S600+ or via a supervisory computer.

You then have two options for accepting the prove results:

- If you select **ACCEPT**, the currently running batch is retroactively adjusted with the new factor.
- If you select **ACCEPT NO ADJUST**, no adjustment is performed on the currently running batch.

### B.2.5.1 Default Prove Sequence Stages

The prover sequence functions in stages. *Table B-14* shows the default stages for a typical application’s normal, reprove, and abort situations.

If an abort occurs either automatically or by operator command then the prove sequence stage changes to Aborted. No further action is taken until the computer receives either a Continue command to initiate a re-prove or a Terminate command to finish the sequence.

*Table B-14. Default Prove Sequence Stages*

Stage	Display	Description
0	IDLE	Halted: idle, await Start command
1	INITIALISE	Initialise
2	PULSES ON	Turn proving stream pulses on
41	ENABLE HYDRAULICS	Enable piston hydraulics (execute Run Control stages)
16	PRV FLOW/T/P STAB	Hold stable temperature, pressure and flowrate
18	PROOF RUN	Perform proof runs (execute Run Control stages)
19	KF DOWNLOAD	K-factor and data download
20	AWAIT REPROVE	Halted: prove runs complete, await Continue/Terminate command
26	ABORTED STAGE	Halted: sequence aborted, await Continue/Terminate command
<b>Continue (Reprove)</b>		
29	RE STAB CHECKS	Hold stable temperature, pressure and flowrate
18	PROOF RUN	Perform proof runs (execute Run Control stages)
<b>Terminate</b>		
25	PS PULSES OFF	Turn proving stream raw pulses off
30	TERMINATE	Terminate (return to idle)

### B.2.5.2 Complete Sequence Stage Descriptions

*Table B-15* shows all the stages of a prove sequence.

*Table B-15. Complete Prove Sequence Stages*

Stage	Title	Description
0	Idle	Wait for a command to start the sequence, then proceed to stage 1 (Validate and Initialise).

Stage	Title	Description
1	<b>Validate + Initialise</b>	<p>Verify:</p> <ul style="list-style-type: none"> <li>▪ The proving stream is flowing.</li> <li>▪ The proving stream is not in maintenance mode.</li> <li>▪ Telemetry to the proving stream is OK.</li> <li>▪ The prove permit state (run control status) is OK.</li> </ul> <p>Initialise:</p> <ul style="list-style-type: none"> <li>▪ Copy the proving stream meter variables into the proving set.</li> <li>▪ Copy the product stream product data into the proving set.</li> <li>▪ Initialise proof run date (via Initialise command to run control task).</li> <li>▪ Determine required proof flowrate from current rate (snapshot) or preset flowrate.</li> <li>▪ Save all FCV settings.</li> </ul> <p>Proceed to stage 2 (Pulses On).</p>
2	<b>Pulses On</b>	<p>Command all online streams to turn pulses off  Command proving stream to turn pulses on  Wait for pulses to be aligned  Proceed to stage 3 (Prover FCV Initialise)  Abort:</p> <ul style="list-style-type: none"> <li>▪ If an abort command is issued.</li> <li>▪ If proving stream telemetry fails.</li> <li>▪ If prove permit state (run control status) is off.</li> <li>▪ If no flow at proving stream.</li> <li>▪ If proving stream raw pulse output is not switched on.</li> <li>▪ If proving stream is in maintenance mode.</li> <li>▪ If peer status is not duty.</li> </ul>
3	<b>Prover FCV initialise</b>	<p>Set prover FCV manual output to initial output  Set prover FCV mode to manual  Set proving stream FCV tracking on  Set proving stream FCV mode to manual  Proceed to stage 4 (Open prover outlet)  Abort:</p> <ul style="list-style-type: none"> <li>▪ If an abort command is issued.</li> <li>▪ If proving stream telemetry fails.</li> <li>▪ If prove permit state (run control status) is off.</li> <li>▪ If no flow at proving stream.</li> <li>▪ If proving stream raw pulse output is not switched on.</li> <li>▪ If proving stream is in maintenance mode.</li> <li>▪ If peer status is not duty.</li> </ul>
4	<b>Prover open outlet</b>	<p>Command Prover Outlet Valve to open  Wait for valve to reach position  Proceed to stage 5 (Non-proving stream close prover inlet)  Abort:</p> <ul style="list-style-type: none"> <li>▪ If an abort command is issued.</li> <li>▪ If proving stream telemetry fails.</li> <li>▪ If prove permit state (run control status) is off.</li> <li>▪ If no flow at proving stream.</li> <li>▪ If proving stream raw pulse output is not switched on.</li> <li>▪ If proving stream is in maintenance mode.</li> <li>▪ If peer status is not duty.</li> <li>▪ If the valve fails to reach position.</li> </ul>

<b>Stage</b>	<b>Title</b>	<b>Description</b>
<b>5</b>	<b>Non-proving stream close prover inlet</b>	<p>Command non-proving streams Prover Inlet Valves to close                      Wait for valves to reach position                      Proceed to stage 6 (Proving stream open prover inlet)                      Abort:</p> <ul style="list-style-type: none"> <li>▪ If an abort command is issued.</li> <li>▪ If proving stream telemetry fails.</li> <li>▪ If prove permit state (run control status) is off.</li> <li>▪ If no flow at proving stream.</li> <li>▪ If proving stream raw pulse output is not switched on.</li> <li>▪ If proving stream is in maintenance mode.</li> <li>▪ If peer status is not duty.</li> <li>▪ If the valves are not correctly aligned.</li> <li>▪ If the valve fails to reach position.</li> </ul>
<b>6</b>	<b>Proving stream open prover inlet</b>	<p>Command proving streams Prover Inlet Valve to open                      Wait for valve to reach position                      Proceed to stage 7 (Proving stream close stream outlet)                      Abort:</p> <ul style="list-style-type: none"> <li>▪ If an abort command is issued.</li> <li>▪ If proving stream telemetry fails.</li> <li>▪ If prove permit state (run control status) is off.</li> <li>▪ If no flow at proving stream.</li> <li>▪ If proving stream raw pulse output is not switched on.</li> <li>▪ If proving stream is in maintenance mode.</li> <li>▪ If peer status is not duty.</li> <li>▪ If the valves are not correctly aligned.</li> <li>▪ If the valve fails to reach position.</li> </ul>
<b>7</b>	<b>Proving stream close stream outlet</b>	<p>Command proving streams Outlet Valve to close                      Wait for valve to reach position                      Proceed to stage 41 (Enable Hydraulics)                      Abort:</p> <ul style="list-style-type: none"> <li>▪ If an abort command is issued.</li> <li>▪ If proving stream telemetry fails.</li> <li>▪ If prove permit state (run control status) is off.</li> <li>▪ If no flow at proving stream.</li> <li>▪ If proving stream raw pulse output is not switched on.</li> <li>▪ If proving stream is in maintenance mode.</li> <li>▪ If peer status is not duty.</li> <li>▪ If the valves are not correctly aligned.</li> <li>▪ If the valve fails to reach position.</li> </ul>
<b>8</b>	<b>Not used</b>	
<b>9</b>	<b>Non-proving stream FCVS track</b>	<p>Set FCV for non-proving streams to tracking                      Proceed to stage 10 (Non-proving stream flow balance)                      Abort:</p> <ul style="list-style-type: none"> <li>▪ If an abort command is issued.</li> <li>▪ If proving stream telemetry fails.</li> <li>▪ If prove permit state (run control status) is off.</li> <li>▪ If no flow at proving stream.</li> <li>▪ If proving stream raw pulse output is not switched on.</li> <li>▪ If proving stream is in maintenance mode.</li> <li>▪ If peer status is not duty.</li> <li>▪ If the valves are not correctly aligned.</li> </ul>



Stage	Title	Description
10	<b>Non-proving stream flow balance</b>	<p>Enable flow balancing for non-proving streams</p> <p>Flow error = proving stream flowrate - (selected proof flowrate + offset).</p> <p>If the error is too low then:</p> <ul style="list-style-type: none"> <li>▪ If there are no on-line streams then go to abort stage.</li> <li>▪ Turn down value = abs (error / no. of on line none proving streams).</li> <li>▪ For each on line proving stream, new setpoint = current rate - turn down.</li> </ul> <p>If all new set points (for each stream) are within the low flow range then download the new set points and delay for adjustment prior to rechecking the flow error.</p> <p>If any new set point is less than the low flow range then go to stage 12 (operator close)</p> <p>If the error is too high then:</p> <ul style="list-style-type: none"> <li>▪ If there are no on-line streams then go to abort stage.</li> <li>▪ Turn up value = error / no. of on line none proving streams.</li> <li>▪ For each on line proving stream, new setpoint = current rate + turn up.</li> </ul> <p>If all new set points (for each stream) are within the high flow range then download the new set points and delay for adjustment prior to rechecking the flow error.</p> <p>If any new set point is higher than the low flow range then go to stage 13 (operator open).</p> <p>Proceed to stage 14 if the error is within tolerance (Non-proving stream FCV manual).</p> <p>Abort:</p> <ul style="list-style-type: none"> <li>▪ If an abort command is issued.</li> <li>▪ If proving stream telemetry fails.</li> <li>▪ If prove permit state (run control status) is off.</li> <li>▪ If no flow at proving stream.</li> <li>▪ If proving stream raw pulse output is not switched on.</li> <li>▪ If proving stream is in maintenance mode.</li> <li>▪ If peer status is not duty.</li> <li>▪ If the valves are not correctly aligned.</li> <li>▪ If the valve fails to reach position.</li> <li>▪ If flow balance is not achieved (timeout / hold fails).</li> </ul>
11	<b>Not used</b>	
12	<b>Close suspend</b>	<p>Flow balancing – wait for operator to close stream</p> <p>Return to flow balancing stage 10 if continue command issued</p> <p>Abort:</p> <ul style="list-style-type: none"> <li>▪ If an abort command is issued.</li> <li>▪ If proving stream telemetry fails.</li> <li>▪ If prove permit state (run control status) is off.</li> <li>▪ If no flow at proving stream.</li> <li>▪ If proving stream raw pulse output is not switched on.</li> <li>▪ If proving stream is in maintenance mode.</li> <li>▪ If peer status is not duty.</li> <li>▪ If the valves are not correctly aligned.</li> <li>▪ If the valve fails to reach position.</li> <li>▪ If flow balance is not achieved (timeout / hold fails).</li> </ul>

<b>Stage</b>	<b>Title</b>	<b>Description</b>
<b>13</b>	<b>Open suspend</b>	<p>Flow balancing – wait for operator to open stream Return to flow balancing stage 10 if continue command issued Abort:</p> <ul style="list-style-type: none"> <li>▪ If an abort command is issued.</li> <li>▪ If proving stream telemetry fails.</li> <li>▪ If prove permit state (run control status) is off.</li> <li>▪ If no flow at proving stream.</li> <li>▪ If proving stream raw pulse output is not switched on.</li> <li>▪ If proving stream is in maintenance mode.</li> <li>▪ If peer status is not duty.</li> <li>▪ If valves are not correctly aligned.</li> <li>▪ If the valve fails to reach position.</li> <li>▪ If flow balance is not achieved (timeout / hold fails).</li> </ul>
<b>14</b>	<b>Non-proving stream FCVS manual</b>	<p>Set all non-proving stream FCV tracking on Set all non-proving stream FCV mode to manual Proceed to stage 15 (Prover flowrate stability) Abort:</p> <ul style="list-style-type: none"> <li>▪ If an abort command is issued.</li> <li>▪ If proving stream telemetry fails.</li> <li>▪ If prove permit state (run control status) is off.</li> <li>▪ If no flow at proving stream.</li> <li>▪ If proving stream raw pulse output is not switched on.</li> <li>▪ If proving stream is in maintenance mode.</li> <li>▪ If peer status is not duty.</li> <li>▪ If the valves are not correctly aligned.</li> </ul>
<b>15</b>	<b>Prover flowrate stability</b>	<p>Set prover FCV to selected prove flow rate + offset Set prover FCV mode to auto Set prover FCV tracking to on Hold proving stream flow rate within tolerance for a user configurable time Proceed to stage 16 (Temperature / Pressure Stability) Abort:</p> <ul style="list-style-type: none"> <li>▪ If an abort command is issued.</li> <li>▪ If proving stream telemetry fails.</li> <li>▪ If prove permit state (run control status) is off.</li> <li>▪ If no flow at proving stream.</li> <li>▪ If proving stream raw pulse output is not switched on.</li> <li>▪ If proving stream is in maintenance mode.</li> <li>▪ If peer status is not duty.</li> <li>▪ If the valves are not correctly aligned.</li> <li>▪ If stability not achieved.</li> </ul>

Stage	Title	Description
16	<b>Synchronise with Run Control (Temperature / pressure stability)</b>	<p>Hold stability for a user-configurable time            Proceed to stage 17 (Prover FCV manual)</p> <p>Abort:</p> <ul style="list-style-type: none"> <li>▪ If an abort command is issued.</li> <li>▪ If proving stream telemetry fails.</li> <li>▪ If prove permit state (run control status) is off.</li> <li>▪ If no flow at proving stream.</li> <li>▪ If proving stream raw pulse output is not switched on.</li> <li>▪ If proving stream is in maintenance mode.</li> <li>▪ If peer status is not duty.</li> <li>▪ If the valves are not correctly aligned.</li> <li>▪ If stability not maintained.</li> </ul>
17	<b>Prover FCV manual</b>	<p>Set prover FCV tracking on            Set prover FCV mode to manual            Proceed to stage 18 (Proof runs)</p> <p>Abort:</p> <ul style="list-style-type: none"> <li>▪ If an abort command is issued.</li> <li>▪ If proving stream telemetry fails.</li> <li>▪ If prove permit state (run control status) is off.</li> <li>▪ If no flow at proving stream.</li> <li>▪ If proving stream raw pulse output is not switched on.</li> <li>▪ If proving stream is in maintenance mode.</li> <li>▪ If peer status is not duty.</li> <li>▪ If the valves are not correctly aligned.</li> </ul>
18	<b>Synchronise with Run Control (Proof runs)</b>	<p>Start the prove runs (via Start command to run control task).            On success proceed to stage 19 (KF download)</p> <p>Abort:</p> <ul style="list-style-type: none"> <li>▪ If a run fails (such as a timeout for a sphere switch).</li> <li>▪ If an abort command is issued.</li> <li>▪ If proving stream telemetry fails.</li> <li>▪ If prove permit state (run control status) is off.</li> <li>▪ If no flow at proving stream.</li> <li>▪ If proving stream raw pulse output is not switched on.</li> <li>▪ If proving stream is in maintenance mode.</li> <li>▪ If peer status is not duty.</li> <li>▪ If the valves are not correctly aligned.</li> </ul>
19	<b>K-factor Download</b>	<p>Copy proof K-factor, meter factor, flow rate, and frequency into proving stream data points for subsequent telemetry download.</p> <p><b>Notes:</b></p> <ul style="list-style-type: none"> <li>▪ The stream metering calculations do not use these until commanded separately.</li> <li>▪ If the historical meter factor option is enabled then the historical meter factors and deviations arrays are also copied.</li> </ul> <p>Proceed to stage 20 (Await reprove)</p>
20	<b>Await reprove</b>	<p>Go to stage 22 (Proving stream open stream outlet) if the Terminate or abort command is issued.</p> <p>Go to stage 29 (Stability Checks) if Continue (Reprove) command is issued.</p>
21	<b>Not used</b>	

<b>Stage</b>	<b>Title</b>	<b>Description</b>
<b>22</b>	<b>Proving stream open stream outlet</b>	<p>Command proving stream Outlet Valve to open                      Wait for valve to reach position                      Proceed to stage 23 (Proving stream close prover inlet)</p> <p>Abort:</p> <ul style="list-style-type: none"> <li>▪ If an abort command is issued.</li> <li>▪ If proving stream telemetry fails.</li> <li>▪ If prove permit state (run control status) is off.</li> <li>▪ If no flow at proving stream.</li> <li>▪ If proving stream raw pulse output is not switched on.</li> <li>▪ If proving stream is in maintenance mode.</li> <li>▪ If peer status is not duty.</li> <li>▪ If valve fails to reach position.</li> </ul>
<b>23</b>	<b>Proving stream close prover inlet</b>	<p>Command proving stream Prover Inlet Valve to close                      Wait for valve to reach position                      Proceed to stage 24 (Restore FCV) or stage 25 (Proving stream pulses off)</p> <p>Abort:</p> <ul style="list-style-type: none"> <li>▪ If an abort command is issued.</li> <li>▪ If proving stream telemetry fails.</li> <li>▪ If prove permit state (run control status) is off.</li> <li>▪ If no flow at proving stream.</li> <li>▪ If proving stream raw pulse output is not switched on.</li> <li>▪ If proving stream is in maintenance mode.</li> <li>▪ If peer status is not duty.</li> <li>▪ If the valve fails to reach position.</li> </ul>
<b>24</b>	<b>Restore FCVS</b>	<p>Reset FCV's to previous (pre-prove) settings as noted in stage 1                      Proceed to stage 25 (Proving stream pulses off)</p> <p>Abort:</p> <ul style="list-style-type: none"> <li>▪ If an abort command is issued.</li> <li>▪ If proving stream telemetry fails.</li> <li>▪ If prove permit state (run control status) is off.</li> <li>▪ If no flow at proving stream.</li> <li>▪ If proving stream raw pulse output is not switched on.</li> <li>▪ If proving stream is in maintenance mode.</li> <li>▪ If peer status is not duty</li> </ul>
<b>25</b>	<b>Proving stream pulses off</b>	<p>Command proving stream to turn pulses off.                      Wait for the pulses to be turned off                      Proceed to stage 1</p> <p>Abort:</p> <ul style="list-style-type: none"> <li>▪ If an abort command is issued.</li> <li>▪ If proving stream telemetry fails.</li> <li>▪ If prove permit state (run control status) is off.</li> <li>▪ If no flow at proving stream.</li> <li>▪ If proving stream is in maintenance mode.</li> <li>▪ If peer status is not duty</li> </ul>
<b>26</b>	<b>Aborted stage</b>	<p>An abort condition has occurred.                      Go to the next relevant stage if the Terminate command is issued.                      Go to stage 29 (Stability Checks) if Continue (Reprove) command is issued.</p>
<b>27</b>	<b>Not used</b>	
<b>28</b>	<b>Not used</b>	

Stage	Title	Description
29	<b>Synchronise with Run Control (Stability checks)</b>	Wait to achieve stability (via Stabilise command to run control task) for temperatures, pressure rate of change. Upon achieving stability, wait for stability to be held for a user-configurable time. Proceed to the stage 18 (Proof runs).
30	<b>Terminate</b>	Ensure the run control sequence terminates. Return to stage 1 (Idle).
31 to 40	<b>User Stages</b>	Requires the implementation of the expseq.txt file and a logicalc to perform any specific functionality.
41	<b>Enable Hydraulics</b>	Command prover to turn on the compact prover piston hydraulics (via Enable hydraulics command to run control task) Proceed to stage 9 (Non-proving stream FCV track) or stage 16 (Temperature / Pressure Stability) Abort: <ul style="list-style-type: none"> <li>▪ If an abort command is issued.</li> <li>▪ If proving stream telemetry fails.</li> <li>▪ If prove permit state (run control status) is off.</li> <li>▪ If no flow at proving stream.</li> <li>▪ If proving stream raw pulse output is not switched on.</li> <li>▪ If proving stream is in maintenance mode.</li> <li>▪ If peer status is not duty</li> </ul>
42	<b>User Comms Suspend 1</b>	Suspends the prover / stream communications. Requires the implementation of the expseq.txt file and a logicalc to perform any specific functionality.
43	<b>User Comms Normal 1</b>	Re-enables the prover / stream communications. Requires the implementation of the expseq.txt file and a logicalc to perform any specific functionality.
44	<b>User Comms Suspend 2</b>	Suspends the prover / stream communications. Requires the implementation of the expseq.txt file and a logicalc to perform any specific functionality.
45	<b>User Comms Normal 2</b>	Re-enables the prover / stream communications. Requires the implementation of the expseq.txt file and a logicalc to perform any specific functionality.

### B.2.5.3 Prove Sequence Abort Index

Table B-16 shows the abort values for a prove sequence.

Table B-16. Prove Sequence Abort Index

Value	Display	Description
1	OP ABORT	Operator Requested Abort
2	Not Used	
3	PS TELEM FAIL	Proving Stream Telemetry Fail
4	RUN CTL BUSY	Run Control Task Busy
5	METER NO FLOW	No Flow at Meter
6	RUN CTL ABORT	Run Control Task Aborted
7	ILLEGAL PULSES	More than one stream has raw pulses enabled.
8	ANY TELEM FAIL	Non Proving Stream Telemetry Fail
9	NPS PRV I-VLV OPEN	Non Proving Stream Prover Valve Not Closed
10	PS PRV I-VLV CLOSED	Proving Stream Prover Offtake Valve Not Open
11	PS STR O-VLV OPEN	Proving Stream Outlet Valve Not Closed
12	PRV I-VLV CLOSED	Prover Inlet Valve Not Open
13	PRV O-VLV CLOSED	Prover Outlet Valve Not Open

Value	Display	Description
14	PS IN MAINT	Proving Stream Is In Maintenance Mode
15	FBAL TIMEOUT	Flow Balance Timeout
16	FBAL NO NPS ON LINE	Flow Balance Error - No Non Proving Streams On-line
17	FBAL NO NPS IN AUTO	Flow Balance Error - No Non Proving Streams In Auto
18	FBAL HOLD FAIL	Flow Balance Error - Stability Not Achieved
19	PS I-ISL-VLV CLOSED	Proving Stream Inlet Isolation Valve Not Open
20	PS O-ISL-VLV CLOSED	Proving Stream Header Isolation Valve Not Open
21	PS P-ISL-VLV CLOSED	Proving Stream Prover Isolation Valve Not Open
22	PEER STATUS STANDBY	Unit is in standby mode when peer-to-peer is configured

### B.2.6 Prover Run Control Stages

The Run Control sequence is specific to the type of prover (such as a bi-direction or uni-directional [ball] prover, a compact prover, or a master meter). The Run Control sequence initiates the prove runs and performs the calculations that produce a K-factor and meter factor when the runs complete.

Normally the sequence runs when commanded by the Prove Sequence at stage 18 (Perform Proof Run). However, you can initiate it from the S600+ front panel display or (by using custom control) from elsewhere.

The Prover Run sequence below shows the default stage sequencing for a typical compact prove.

Table B-17. Compact Prover Run Control Stages

Stage	Display	Description
0	IDLE	Halted: idle
1	INITIALISE	Initialise run data
2	AWAIT HYD CMD	Halted: await Enable Hydraulics command
3	WAIT READY	Wait for the Ready signal (piston upstream)
4	AWAIT STAB CMD	Halted: await Stabilise command
5	WAIT STAB	Wait until stability is achieved
7	AWAIT RUN CMD	Halted: await start runs command
8	CONTROL PLENUM	Balance the plenum pressure
9	PRE FLIGHT AVG	Average tmp/prs etc prior to launch
10	LAUNCH	Issue Run command
11	WAIT 1ST HIT	Wait detector first hit
12	WAIT 2ND HIT	Wait detector second hit
13	PASS CALCS	Perform pass calculations
14	RETRIEVE	Return piston to upstream (if another pass go to stage 9)
15	RUN CALCS	Perform run calculations
16	AVG CALCS	Perform run average calculations
21	STD POST RUN	No action
17	STD RPT CHECKS	Perform repeatability checks (if success go to stage 19)
20	CHECK RUNS EXCEEDED	Check runs exceeded (if yes go to stage 18 else stage 8)
19	FINAL AVG	Perform final average calculations

Stage	Display	Description
22	MF DEVIATION CHECKS	Perform meter factor deviation checks. <b>Note:</b> This stage is performed <b>only</b> if you configure the meter normal flow to a value greater than zero ( <b>Aramco-style linearisation</b> ) and you select “Product Table with History” when you create your configuration.
23	WAIT REJECT COMMAND	Allow a time-out for rejecting the current prove. If the time-out elapses then print the proof report. This stage only occurs if you configure the meter normal flow rate to value great than zero. <b>Note:</b> This stage is performed <b>only</b> if you configure the meter normal flow to a value greater than zero ( <b>Aramco-style linearisation</b> ).
24	REPORT STAGE	Generates the proof report.
18	FINAL	Halted: final – await Terminate/Reprove command.

You can also enable user stages on the PC Setup Run Data screen. These invoke a LogiCalc which you can edit to provide user specific logic as the prove progresses. Example LogiCalcs are included in the C:\Users\\Config600 3.3\lclib\prover directory. Copy one of these to the C:\Users\\Config600 3.3\Configs\Project\LogiCalc directory so that you can edit it to be compatible with your configuration and then download it to the S600+ with the configuration.

---

**Notes:**

- You can enable user stages by editing a configuration using the System Editor.
  - The displays showing the detector hit only update during a prove. They cannot be used independently for testing the hardware.
- 

### B.2.6.1 Run Control Stage Description

Table B-18 shows all the stages of a Run Control sequence.

Table B-18. Compact Run Control Stages

Run Stage	Description
	<b>Idle</b> Wait for the Initialise command to start the run control sequence. Proceed to next stage only if the prove is permitted (that is, the run control stage is ‘idle’ or ‘final’ and the available signal is zero). The available signal is normally assigned to a digital input which may be connected to a valve or a key-switch.
<b>1</b>	<b>Initialise Run Data</b> Zero down all run data and arrays. Proceed to next stage.

<b>Run Stage</b>	<b>Description</b>
<b>2</b>	<p><b>Wait Prior to Enabling the Hydraulics</b></p> <p>Issue hardware command to enable hydraulics, then proceed to the next stage.</p> <p>Abort:</p> <ul style="list-style-type: none"> <li>▪ If the prove is no longer permitted.</li> <li>▪ If the base volume has changed.</li> <li>▪ If the Terminate command is issued.</li> </ul>
<b>3</b>	<p><b>Wait Prover Ready Signal</b></p> <p>Wait for the prover ready (upstream) signal to be set (indicating the piston is in the upstream position). When set, proceed to the next stage.</p> <p>Abort:</p> <ul style="list-style-type: none"> <li>▪ If ready wait timer expires.</li> <li>▪ If the prove is no longer permitted.</li> <li>▪ If the base volume has changed.</li> <li>▪ If the Terminate command is issued.</li> </ul>
<b>4</b>	<p><b>Wait Prior To Stability Checks</b></p> <p>Wait for Stabilise command then proceed to next stage.</p> <p>Abort:</p> <ul style="list-style-type: none"> <li>▪ If the prove is no longer permitted.</li> <li>▪ If the base volume has changed.</li> <li>▪ If Terminate command is issued.</li> </ul>
<b>5</b>	<p><b>Wait Stability</b></p> <p>If stability override is selected, ignore the checks and proceed to the next stage.</p> <p>Set stability wait timer running.</p> <p>Continuously monitor deviations for:</p> <ul style="list-style-type: none"> <li>▪ prover inlet pressure vs. prover outlet pressure</li> <li>▪ meter pressure vs. prover inlet pressure</li> <li>▪ meter pressure vs. prover outlet pressure</li> <li>▪ prover inlet temperature vs. prover outlet temperature</li> <li>▪ meter temperature vs. prover inlet temperature</li> <li>▪ meter temperature vs. prover outlet temperature</li> </ul> <p>Continuously monitor (over 5-second periods) rates of change for:</p> <ul style="list-style-type: none"> <li>▪ prover inlet pressure</li> <li>▪ prover outlet pressure</li> <li>▪ prover inlet temperature</li> <li>▪ prover outlet temperature</li> <li>▪ meter flowrate</li> </ul> <p>Proceed to next stage when stability is achieved.</p> <p>Abort:</p> <ul style="list-style-type: none"> <li>▪ If stability wait timer expires, that is stability not achieved.</li> <li>▪ If the prove is no longer permitted.</li> <li>▪ If the base volume has changed.</li> <li>▪ If Terminate command is issued.</li> </ul>
<b>6</b>	<p><b>Hold Stability</b></p> <p>If stability override is selected, ignore the checks and proceed to the next stage.</p> <p>Set stability hold timer running.</p> <p>Check that stability is maintained for the timer period by repeating stability checks from stage 5.</p> <p>Proceed to next stage when stability hold timer expires.</p> <p>Abort:</p> <ul style="list-style-type: none"> <li>▪ If any of the stability checks fail.</li> <li>▪ If the prove is no longer permitted.</li> <li>▪ If the base volume has changed.</li> <li>▪ If the Terminate command is issued.</li> </ul>



Run Stage	Description
7	<p><b>Wait Prior to Starting the Runs</b></p> <p>Wait for the Start Runs command. Proceed to next stage. Abort:</p> <ul style="list-style-type: none"><li>▪ If the prove is no longer permitted.</li><li>▪ If the base volume has changed.</li><li>▪ If the Terminate command is issued.</li></ul>
8	<p><b>Control Plenum Pressure</b></p> <p>Set pass number = 1, increment run number. Set plenum timer running. Adjust plenum pressure if necessary. The adjustment can be ignored by setting the plenum timer to zero.</p> <ul style="list-style-type: none"><li>▪ Inputs: prover pressure, plenum pressure (psig)</li><li>▪ Constants: R (such as 3.5 for 8" prover), N2K (such as 60 psig), and tolerance (such as 2 psig)</li><li>▪ Formula: required pressure = prover pressure / R + N2K.<ul style="list-style-type: none"><li>○ if plenum pressure &gt; (required pressure + tolerance) then open the vent solenoid.</li><li>○ if plenum pressure &lt; (required pressure - tolerance) then open the charge solenoid (timeout if N2 bottle has suspected low pressure).</li><li>○ if plenum pressure &lt; (required pressure + tolerance) and plenum pressure &gt; (required pressure - tolerance) then proceed to next stage.</li></ul></li><li>▪ Outputs: charge solenoid and vent solenoid (digital outputs)</li></ul> <p>Abort:</p> <ul style="list-style-type: none"><li>▪ If pressure not achieved within timeout period.</li><li>▪ If the prove is no longer permitted.</li><li>▪ If the base volume has changed.</li><li>▪ If the Terminate command is issued.</li></ul>
9	<p><b>Pre-flight Average</b></p> <p>Average all stream and prover variables which serve as inputs into the calculations.</p> <p><b>Note:</b> The system would normally sample and average data during the period between detector switches. However, if this period is very short or if the mechanical arrangement of the hardware (such as a prover-mounted densitometer) makes the measured values unreliable, they can be sampled at this point instead. Trigger the sampling mechanism by specifying the number of samples (to a maximum of 3000). If the number of samples is zero then proceed to the next stage.</p> <p>Check that stability is maintained while averaging unless stability override is selected.</p> <p>Abort:</p> <ul style="list-style-type: none"><li>▪ If number of samples is greater than 3000.</li><li>▪ If the prove is no longer permitted.</li><li>▪ If the base volume has changed.</li><li>▪ If Terminate command is issued.</li></ul>

Run Stage	Description
<b>10</b>	<p><b>Launch (Run)</b></p> <p>Reset internal prover hardware.            Set the launch timer running.            Set the run digital output when the hardware indicates ready.            When the prover ready (upstream) signal clears proceed to the next stage.</p> <p>Abort:</p> <ul style="list-style-type: none"> <li>▪ If ready signal doesn't clear within launch timeout period.</li> <li>▪ If the prove is no longer permitted.</li> <li>▪ If the base volume has changed.</li> <li>▪ If Terminate command is issued.</li> </ul>
<b>11</b>	<p><b>Wait Detector 1st Hit</b></p> <p>Set switch timer running – uses flight timer value.            Proceed to next stage when detects hit 1.</p> <p>Abort:</p> <ul style="list-style-type: none"> <li>▪ If flight timer expires.</li> <li>▪ If switch sequence error.</li> <li>▪ If pulse lock is lost (if PIM)</li> <li>▪ If the prove is no longer permitted.</li> <li>▪ If the base volume has changed.</li> <li>▪ If Terminate command is issued.</li> </ul>
<b>12</b>	<p><b>Wait Detector 2nd Hit</b></p> <p>Set flight timer running.            Average all stream and prover variables (which serve as inputs into the calculations) to activate set the number of samples required to zero (see stage 9).            Check stability is maintained for this period between detectors by repeating the stability checks from stage 5.            Proceed to next stage when detects hit 2.</p> <p>Abort:</p> <ul style="list-style-type: none"> <li>▪ If stability checks fail.</li> <li>▪ If flight timer expires.</li> <li>▪ If switch sequence error.</li> <li>▪ If number of samples is greater than 3000.</li> <li>▪ If pulse lock is lost (if PIM)</li> <li>▪ If the prove is no longer permitted.</li> <li>▪ If the base volume has changed.</li> <li>▪ If Terminate command is issued.</li> </ul>
<b>13</b>	<p><b>Pass Calculations</b></p> <p>Run the calculations for this pass and store the results.</p> <p>Abort:</p> <ul style="list-style-type: none"> <li>▪ If very few pulses or very short flight time.</li> <li>▪ If calculations fail.</li> </ul>
<b>14</b>	<p><b>Retrieve</b></p> <p>Clear the run digital output signal.            Set retrieve timer running.            Wait for the prover ready (upstream) signal.            If the required number of passes has been performed then go to stage 15.            If more passes are required then go to stage 9 for the next pass.</p> <p>Abort:</p> <ul style="list-style-type: none"> <li>▪ If retrieve timer expires.</li> <li>▪ If the prove is no longer permitted.</li> <li>▪ If the base volume has changed.</li> <li>▪ If terminate command is issued.</li> </ul>

Run Stage	Description
15	<p><b>Run Calculations</b></p> <p>Perform the end of run calculations.            Proceed to the next stage if all the calculations are valid.            Abort if there is a calculation failure (such as the K-factor is out of range).</p>
16	<p><b>Run Average Calculations</b></p> <p>Average the individual run data either for the runs so far or the last <math>n</math> runs (where <math>n</math> is the required number of good runs) and store the results.            Proceed to stage 21 (Post Run Logic).</p>
17	<p><b>Repeatability Checks</b></p> <p>If the required number of runs <b>has not</b> been performed, then proceed to stage 20.            If the required number of runs (<math>n</math>) <b>has</b> been performed, then check each of the last <math>n</math> run's K-factor against the average.            If the K-factors are <b>within</b> tolerance, then proceed to final calculations stage 19 (Final Average Calculations). If the K-factors are <b>not within</b> tolerance, proceed to stage 20 to check maximum runs.</p>
18	<p><b>Wait Terminate/Reprove Command</b></p> <p>Wait for the operator or supervisory computer to issue the run control command to terminate the proof or to start a re-prove.            If the command is Initialise then proceed to stage 1 (Initialize Run Data) to start a re-prove.            If the command is Terminate then disable the hydraulics and proceed to stage 0 (Idle).</p>
19	<p><b>Final Average Calculations</b></p> <p>Average the run data for the <math>n</math> good runs.            Calculate the final K-factor and meter factor.            Print the final proof report.            Proceed to stage 22.</p>
20	<p><b>Maximum Runs</b></p> <p>If the maximum number of runs has been exceeded then proceed to stage 18. Otherwise, proceed to stage 8 to start the next run.</p>
21	<p><b>Perform Meter Factor Deviation Checks</b></p> <p>Perform tolerance tests (calculated meter factor versus initial base meter factor: maximum deviation of 0.25% and calculated meter factor versus average of saved historical meter factors: maximum deviation of 0.1%)            Only valid meter factors at normal flow rate are incorporated in the historical database. When the limits from either test exceeds the meter factor they are not entered in the historical database. Proving reports are annotated as "ABORTED" with cause of failure stated.            Proceed to stage 20 if any of the tolerance tests fail.            Proceed to next stage.</p> <p><b>Note:</b> This stage is performed <b>only</b> if you configure the meter normal flow rate to a value greater than zero (<b>Aramco-style linearisation</b>) and you select "Product Table with History" when you create your configuration.</p>

Run Stage	Description
22	<p><b>Await for Current Prove to be Rejected</b></p> <p>You can reject the current prove results within a predefined time-out.                      Print report when timer expires.                      Abort if the prove is rejected.                      Proceed to stage 18.</p> <p><b>Note:</b> This stage is performed <b>only</b> if you configure the meter normal flow to a value greater than zero (<b>Aramco-style linearisation</b>).</p>
23	<p><b>Post Run Logic</b></p> <p>No action.                      Proceed to stage 17 (Repeatability Checks).</p>

### B.2.7 Run Stage Abort Index

Following an abort the program displays a value in the Run Control Abort Index display.

Table B-19. Run Stage Abort Index

Value	Display	Description
0	NULL	Not used
1	OPERATOR	Operator abort
2	READY TIMEOUT	Prover ready timeout, piston upstream signal not set
3	SW1 TIMEOUT	<p>Switch 1 timeout (the switch was not hit within the predicted time).</p> <p>To resolve, check wiring; set pre-switch volume to 0; or check that raw pulse bus frequency is greater than 0.</p>
4	SW2 TIMEOUT	<p>Switch 2 timeout (the switch was not hit within the predicted time).</p> <p>To resolve, check wiring; set pre-switch volume to 0; or check that raw pulse bus frequency is greater than 0.</p> <p><b>Note:</b> If the flow computer does not see SW2, check the raw pulse bus.</p>
5	STAB WAIT	Temperature/Pressure/Flowrate wait stability timeout
6	STAB HOLD	Temperature/Pressure/Flowrate hold stability timeout
7	AVG CALC	Average calculation error - number of samples exceeds 3000
8	PASS CALC	Not used
9	FULL CALC	An error occurred when performing a run calculation; see the Run Stage Calculation Index
10	RUNS EXCEEDED	Maximum number of runs exceeded
11	SS ERROR	Detector switch sequence error
12	PLS LOCK LOST	Pulse interpolator module lock lost
13	IO FAIL	I/O module failed to respond to prove request
14	NULL DATA	Pass calculation fail, no pulses or flight time very short. This can occur when noise/signal bounce affects the switch input. Adjust the switch delay.
15	BVOL CHANGED	Base volume changed during prove runs
16	KF/MF RANGE	K-factor or meter factor out of range, even if alarms not configured. To resolve, check the high and low limits for the meter factor, the K-factor, and pulse count objects.
17	PLENUM CTL	Fail to achieve in range plenum pressure timeout
18	PLENUM CONFIG	Plenum pressure config invalid
19	LAUNCH TIMEOUT	Launch timeout

Value	Display	Description
20	RETRIEVE TIMEOUT	Retrieve timeout, ready signal not set
21	UNAVAIL	Prover unavailable
22	INV CALC	Unsupported volume/mass calculations
23	MF DEV INVALID	Failed during meter factor deviation checks

## B.2.8 Run Stage Calculation Index

The Run Stage Calculation Index shows the current prove run calculation. If the calculations cause an abort this value indicates which calculation failed.

*Table B-20. Run Stage Calculation Index*

Value	Display	Description
0	IDLE	No calculation errors
1	CTSP	The calculation to determine the correction factor for the effect of temperature on the steel at the prover (CTSp) failed because the CTSP value is less than 0.5 or greater than 1.5
2	CPSP	The calculation to determine the correction factor for the effect of pressure on the steel at the prover (CPSp) failed because the modulus of elasticity or wall thickness is 0 and the CPSp value is less than 0.5 or greater than 1.5
3	CPLP	The calculation to determine the correction factor for the effect of pressure on the liquid at the prover (CPLp) failed because of low density
4	CPLM	The calculation to determine the correction factor for the effect of pressure on the liquid at the meter (CPLm) failed because of low density
5	CTLP	The calculation to determine the correction factor for the effect of temperature on the liquid at the prover (CTLp) failed because of low density
6	CTLM	The calculation to determine the correction factor for the effect of temperature on the liquid at the meter (CTLm) failed because of low density
7	PRV SVOL/GVOL	The calculation to determine the gross standard volume at the prover (GSVp) failed; no error checks occurred.
8	MTR GVOL/PRV MASS	The calculation to determine the indicated volume at the meter (IVM) failed. For gross volume, this was due either to no K-factor or a pulse count less than 1.0. For prover mass, this was due to lack of a value for gross volume at the prover or a pulse count less than or equal to zero.
9	MTR SVOL/MTR/MASS	The calculation to determine the indicated standard volume at the meter (IVSM) failed because no error checks occurred, no K-factor was available, or the pulse count was less than 1.0
10	K-FACTOR	The calculation to determine the K-factor failed because the value is outside low/high alarm limits
11	METER FACTOR	The calculation to determine the Meter factor failed because the value is outside low/high alarm limits
12	FLOWRATE	The calculation to determine the flowrate failed because the CTLm or the CPLM is less than or equal to 0

## B.2.9 Prove/Stream Data

The prover computer reads the following data from the stream under prove:

- Stream Temperature (in use)

- Stream Pressure (in use)
- Stream Standard Density (in use)
- Alpha Constant K0
- Alpha Constant K1
- Alpha Constant K2
- Equilibrium Vapour Pressure
- Meter factor (in use)
- K-factor (in use)
- CTSm (in use)
- CPSm (in use)
- Flowrate Minimum
- Flowrate Maximum
- FCV Setpoint
- FCV Output
- Reference Temperature
- Meter Density (in use)
- FCV Auto/Manual Status
- FCV Tracking Status
- Volume Correction Rounding Status
- Volume Correction Units Selection
- Volume Correction Product Type
- Volume Correction CPL Option
- Volume Correction Product Subtype
- Volume Correction Density Type
- K-factor Units
- Normal Meter Flow Rate
- Initial Base Meter Factor
- Initial Base Meter Factor Time Stamp
- Base Meter Factor Linearisation Points
- Historical Meter Factors
- Historical Meter Factors Time Stamps

If the prove completes successfully, the following prove data transfers to the stream, but is not used until you accept the data at the stream.

- Proved K-factor
- Proved Meter Factor
- Proved Turbine Frequency
- Proved Flowrate
- Proved Meter Temperature
- Proved Meter Pressure
- Historical Meter Factors

- Historical Meter Factors Time Stamp
- Proved Meter Factor Acceptance Flag

### B.2.10 Prove Reports

The system provides two reports, volume or mass K-factor. Which report generates depends on the K-factor units, pulses/volume, or pulses/mass.

Following are two customized proof reports:

```

=====
1                                METER PROOF REPORT                                06/08/2013  09:58:40
=====

STREAM ON PROOF          : 0
PROVING RATE             :          0.000 m3/h

STANDARD DENSITY         :          0.000 kg/m3
BASE VOLUME              :          0.000 m3
STREAM TEMPERATURE      :          0.000 Deg.C      STREAM PRESSURE : 0.000 barg
PROVER TEMP              :          0.000 Deg.C      PROVER PRESS   : 0.000 barg

   STREAM          PROVER          STANDARD          METER
TRIAL  TEMP        PRESSURE      TEMP        PRESSURE      DENSITY      PULSES      FLOWRATE      K-FACTOR
NO.    (Deg.C)     (barg)      (Deg.C)     (barg)      (kg/m3)     (      )     (m3/h)     (pls/m3)

1         0.00         0.00         0.00         0.00         0.000         0.0         0.0         0.0
2         0.00         0.00         0.00         0.00         0.000         0.0         0.0         0.0
3         0.00         0.00         0.00         0.00         0.000         0.0         0.0         0.0
4         0.00         0.00         0.00         0.00         0.000         0.0         0.0         0.0
5         0.00         0.00         0.00         0.00         0.000         0.0         0.0         0.0
6         0.00         0.00         0.00         0.00         0.000         0.0         0.0         0.0
7         0.00         0.00         0.00         0.00         0.000         0.0         0.0         0.0
8         0.00         0.00         0.00         0.00         0.000         0.0         0.0         0.0
9         0.00         0.00         0.00         0.00         0.000         0.0         0.0         0.0
10        0.00         0.00         0.00         0.00         0.000         0.0         0.0         0.0
11        0.00         0.00         0.00         0.00         0.000         0.0         0.0         0.0
12        0.00         0.00         0.00         0.00         0.000         0.0         0.0         0.0
AVE        0.00         0.00         0.00         0.00         0.000         0.0         0.0         0.0

   CTLM          CPLM          CTSP          CPSP          CTPP          CLPP          FTIME
1         0.000000  0.000000  0.000000  0.000000  0.000000  0.000000  0.000000
2         0.000000  0.000000  0.000000  0.000000  0.000000  0.000000  0.000000
3         0.000000  0.000000  0.000000  0.000000  0.000000  0.000000  0.000000
4         0.000000  0.000000  0.000000  0.000000  0.000000  0.000000  0.000000
5         0.000000  0.000000  0.000000  0.000000  0.000000  0.000000  0.000000
6         0.000000  0.000000  0.000000  0.000000  0.000000  0.000000  0.000000
7         0.000000  0.000000  0.000000  0.000000  0.000000  0.000000  0.000000
8         0.000000  0.000000  0.000000  0.000000  0.000000  0.000000  0.000000
9         0.000000  0.000000  0.000000  0.000000  0.000000  0.000000  0.000000
10        0.000000  0.000000  0.000000  0.000000  0.000000  0.000000  0.000000
11        0.000000  0.000000  0.000000  0.000000  0.000000  0.000000  0.000000
12        0.000000  0.000000  0.000000  0.000000  0.000000  0.000000  0.000000
AVE        0.000000  0.000000  0.000000  0.000000  0.000000  0.000000  0.000000

CURRENT K-FACTOR        :          0.00 pls/m3
NEW K-FACTOR            :          0.00 pls/m3
NEW METER FACTOR        :          0.000000
REPEATABILITY           :          0.000000 %
=====

```

```

=====
2                                PROVING REPORT                                Emerson Process Management
(0)OFFICIAL (0)UNOFFICIAL (0)ABORTED

LOCATION :                AAAAAAA                DATE/TIME : MM/DD/YYYY HH:MM:SS

METER MANUFACTURER:    AAAAAAA                PROVER MANUFACTURER:    AAAAAAA
METER MODEL:           AAAAAAA                PROVER SERIAL NUMBER:   AAAAAAA
=====

```

# Config600 Configuration Software User Manual

METER SERIAL NUMBER: AAAAAAA  
 METER SIZE (mm): 0.000  
 NOMINAL K-FACTOR: 0.000  
 METER TAG NUMBER: AAAAAAA

PRIMARY FLOW COMPUTER: XX:XX:XX:XX:XX:XX

LIQUID: A CRUDE

OBSERVED DENSITY: 0.000 kg/m3 AT 0.00 Deg.C = 0.000 kg/m3 AT 0.000 Deg.C

TRIAL NO.	PULSES TOTAL	TOTAL TIME S	PRESS PROVER barg	METER barg	TEMP PROVER Deg.C	METER Deg.C	TRIAL M.F. Mft
1	0.00	0.00	0.00	0.00	0.000	0.0	0.0
2	0.00	0.00	0.00	0.00	0.000	0.0	0.0
3	0.00	0.00	0.00	0.00	0.000	0.0	0.0
4	0.00	0.00	0.00	0.00	0.000	0.0	0.0
5	0.00	0.00	0.00	0.00	0.000	0.0	0.0
6	0.00	0.00	0.00	0.00	0.000	0.0	0.0
7	0.00	0.00	0.00	0.00	0.000	0.0	0.0
8	0.00	0.00	0.00	0.00	0.000	0.0	0.0
9	0.00	0.00	0.00	0.00	0.000	0.0	0.0
10	0.00	0.00	0.00	0.00	0.000	0.0	0.0
AVE	0.00	0.00	0.00	0.00	0.000	0.0	0.0

REPEATABILITY FOR LAST 10 TRIALS = 0.000 %

- A. TEMP. CORRECTION FACTOR FOR LIQUID IN PROVER (CTLp) 0.000
- B. PRESS. CORRECTION FACTOR FOR LIQUID IN PROVER (CPLp) 0.000
- C. COMBINED CORRECTION FACTOR FOR PROVER (CCFp) 0.000
- D. GROSS STANDARD VOLUME FOR PROVER (GSVp) 0.000 Sm3
- E. INDICATED METER VOLUME (IVm) 0.000 m3
- F. TEMP. CORRECTION FACTOR FOR LIQUID IN METER (CTLm) 0.000
- G. PRESS. CORRECTION FACTOR FOR LIQUID IN METER (CPLm) 0.000
- H. COMBINED CORRECTION FACTOR FOR METER (CCFm) 0.000
- I. GROSS STANDARD VOLUME FOR METER (GSVm) 0.000 Sm3
- J. AVG. METER FLOW RATE 0.000 m3/h
- K. METER FACTOR @ PROVING FLOW RATE 0.000
- L. METER FACTOR @ NORMAL METER FLOW RATE OF 0.000 m3/h 0.000  
 METER FACTOR TEST RESULTS (%): 1) 0.00 2) 0.00
- M. PROVER MASS 0.000 tonne
- N. METER MASS 0.000 tonne

HISTORICAL DATA OF METER FACTORS @ NORMAL METER FLOW RATE OF 0.000 m3/h  
 INITIAL BASE METER FACTOR (DATE: MM/DD/YY) = 0.000

DATE:	MM/DD/YY	MM/DD/YY	MM/DD/YY	MM/DD/YY	MM/DD/YY
FACTOR:	0.000	0.000	0.000	0.000	0.000
DEVIATION(±):	0.00%	0.00%	0.00%	0.00%	0.00%

DATE:	MM/DD/YY	MM/DD/YY	MM/DD/YY	MM/DD/YY	MM/DD/YY
FACTOR:	0.000	0.000	0.000	0.000	0.000
DEVIATION(±):	0.00%	0.00%	0.00%	0.00%	0.00%

PROVED FOR: \_\_\_\_\_ BY : \_\_\_\_\_ DATE: \_\_\_\_\_

WITNESSED BY : \_\_\_\_\_ DATE: \_\_\_\_\_

=====

## B.2.11 Proving Calculations

This section provides information on various calculations used in the prove procedure.

The calculations are for volume or mass K-factor and the choice is determined by the K-factor units, pulses/volume or pulses/mass.

### Average Method

The “average method” option steers how the system performs the final averaging:

- The Meter Factor option calculates a meter factor for each run and takes the average of these to arrive at the final meter factor.



- The K-factor option calculates a K-factor for each run and takes the average of these to arrive at the final K-factor.
- The Pulses option takes the average of the pulses, temperature, pressure, and other variables and performs a final set of calculations using this average data to arrive at the final meter and K-factor.

Options 1 and 2 are equivalent to the “average meter factor” method used for API Ch.12 Section 2 Part 3 Proving reports. Option 3 is equivalent to the ‘average data’ method.

**Standard References** The prover volume correction calculations correspond to those used by the meter under prove, in which the system transfers the calculation steering variables from the stream.

<b>Name</b>	<b>Standard Reference</b>
Averaging Calcs	General mathematic principles
Stability Calcs	General mathematic principles
Correction Factor (CTLm/CTLp)	Corresponds to Meter calculations
Correction Factor (CPLm/CPLp)	Corresponds to Meter calculations
Correction Factor (CTSp/CPSp)	API Ch 12
K-factor/Flowrate	API Ch 12
K-factor Deviation	API Ch 4
K-factor Deviation Statistical Method	NORSOK I-105 Annex F
Meter Factor	API Ch 12

### B.2.11.1 Formulae: General

At the end of a pass, the system calculates a K-factor, flowrate, and frequency based on the uncorrected prover base volume and samples the measured inputs either prior to the piston launch or whilst the piston is between detector hits (the default).

The measured values are averaged for the required number of passes (default of five passes and a maximum of 39 passes) to provide values for the run calculations. (For more than 39 passes, refer to the latest calculation table document available – for Config600 Pro users only.) The run’s K-factor and flowrate are then re-calculated using the pass average meter pulse count (corrected to standard conditions) and the prover base volume (corrected to standard conditions). Final K-factor and flowrate are averaged run values from the required number of good runs (a default of five runs and a maximum of 12 runs).

### B.2.11.2 Formulae: Averaging Calculations

#### Pass Average Data (Sampled during each Pass)

$$X_{pass} = \frac{\sum X_{inst}}{Samples}$$

where:

$X_{pass}$  is the average value of the variable for a single pass  
 $X_{inst}$  is the instantaneous sample value of the variable being averaged

*Samples* is the number of samples taken during the pass

The sampled variables ( $X_{inst}$ ) are:

- Prover temperature
- Prover pressure
- Meter temperature
- Meter pressure
- Meter vapour pressure
- Meter standard density

### Pass Average Frequency (Hz)

$$FREQ_{pass} = \frac{PC}{\Delta t}$$

where:

$FREQ_{pass}$  is the average meter frequency for a single pass  
 $PC$  is the pass pulse count  
 $\Delta t$  is the pass flight time (s)

### Pass Average Flowrate

$$FR_{pass} = \frac{BV}{\Delta t} \times 3600$$

where:

$FR_{pass}$  is the average prover flowrate for a single pass  
 $BV$  is the prover base volume at standard conditions  
 $\Delta t$  is the pass flight time (s)

### Pass K-factor

$$KF_{pass} = \frac{PC}{BV}$$

where:

$KF_{pass}$  is the K-factor for a single pass  
 $PC$  is the pass pulse count  
 $BV$  is the prover base volume at standard conditions

### Run Average Data (Over Number of Passes)

$$X_{run} = \frac{\sum X_{pass}}{N_{pass}}$$

where:

$X_{run}$  the average value of the variable for  $N$  passes  
 $X_{pass}$  the value of the variable for a single pass  
 $N_{pass}$  the number of passes

The run average variables are:

- Pulse count
- Flight time

- Prover temperature
- Prover pressure
- Meter temperature
- Meter pressure
- Meter vapour pressure
- Meter standard density
- Meter frequency

### Final Average Data (Over Consecutive Good Runs)

$$X_{final} = \frac{\sum X_{run}}{N_{run}}$$

where:

- $X_{final}$  the final average value of the variable for  $N$  consecutive good runs
- $X_{run}$  the value of the variable for a single run
- $N_{run}$  the number of consecutive good runs

The final average variables are:

- Pulse count
- Flight time
- Prover temperature (average of inlet and outlet)
- Prover pressure (average of inlet and outlet)
- Meter temperature
- Meter pressure
- Vapour pressure
- Standard density
- Prover density
- Meter density
- Meter frequency
- Prover flowrate
- Alpha
- Prover beta
- Meter beta
- CTSm
- CPSm
- CTLm
- CPLm
- CTSp
- CPSp
- CTLp
- CPLp
- Prover standard volume
- Meter gross volume
- Meter standard volume
- Prover mass
- Meter mass
- K-factor
- Meter factor

### B.2.11.3 Formulae: Stability Calculations Meter/Prover Discrepancy Checks

$$X_{diff} = X_A - X_B$$

where:

$X_A, X_B$  are the variables being compared

The variables compared are:

- Prover temperature – Meter temperature
- Prover pressure – Meter pressure

### Variable Rate of Change

$$X_{rate} = \frac{X_{new} - X_{old}}{Period}$$

where:

$X_{rate}$  the rate of the variable  
 $X_{new}$  the new sample value  
 $X_{old}$  the previous sample value  
 $Period$  the sampling interval

The variables compared are:

- Meter temperature
- Meter pressure
- Meter flowrate

### B.2.11.4 Formulae: Correction Factor (CTLm/CTLp)

#### Correction Factor for the Effect of Temperature on the Liquid

These factors are calculated according to the product, using the same calculations as the meter under prove.

### B.2.11.5 Formulae: Correction Factor (CPLm/CPLp)

#### Correction Factor for the Effect of Pressure on the Liquid

These factors are calculated according to the product, using the same calculations as the meter under prove.

### B.2.11.6 Formulae: Correction Factor (CTSp/CPSp)

#### Correction Factor for the Effect of Temperature on the Prover Steel

$$CTSp = (1 + (T_p - T_b)Y1) \times (1 + (T_{amb} - T_b)Y2)$$

where:

$T_p$  Temperature of the liquid at the prover (°C or °F or °K)  
 $T_b$  Base Temperature (°C or °F or °K)  
 $Y1$  Area Thermal Coefficient of Cubic expansion of the prover tube (°C or °F or °K dependent on temperature units selected)

$T_{amb}$	Ambient Temperature (°C or °F or °K)
$T_{cal}$	Calibration Temperature of the prover (°C or °F or °K)
$Y2$	Linear Thermal Coefficient of Cubic expansion of the prover rod (/°C or /°F or /°K dependent on temperature units selected)

### Correction Factor for the Effect of Pressure on the Prover Steel

$$CPSp = 1 + (P_p - P_b) D/Et$$

where:

$P_p$	Pressure of the liquid at the prover (barg)
$P_b$	Base Pressure (barg)
$D$	Inside diameter of the flow tube (mm)
$E$	Modulus of elasticity of the flow tube steel (bar)
$t$	Wall thickness of the prover flow tube (mm)

---

**Note:** The average  $T_p$ ,  $P_p$  over the run is used for calculating the correction factors.

---

## B.2.11.7 Formulae: Volume Prover Calculations

### Prover Gross Standard Volume (Sm<sup>3</sup>)

$$GSV_{p_{run}} = BV \times CTL_{p_{run}} \times CPL_{p_{run}} \times CTS_{p_{run}} \times CPS_{p_{run}}$$

where:

$BV$	is the entered volume for the prover at standard conditions
$CTL_{p_{run}}$	is the correction factor for the effect of temperature on the liquid at the prover, using the average prover run temperature
$CPL_{p_{run}}$	is the correction factor for the effect of pressure on the liquid at the prover, using the average prover run pressure
$CTS_{p_{run}}$	is the correction factor for the effect of temperature on the steel at the prover, using the average prover run temperature
$CPS_{p_{run}}$	is the correction factor for the effect of pressure on the steel at the prover, using the average prover run pressure

### Meter Indicated Volume (m<sup>3</sup>)

$$IVm_{run} = \frac{PC_{run}}{KFm_{run}}$$

where:

$PC_{run}$	is the run pulse count (pls)
$KFm$	is the meter K-factor (pls/m <sup>3</sup> )

### Meter Indicated Standard Volume (Sm<sup>3</sup>)

$$ISVm_{run} = IVm_{run} \times CTLM_{run} \times CPLM_{run}$$

where:

- $IVm_{run}$  is the indicated volume for the meter
- $CTLm_{run}$  is the correction factor for the effect of temperature on the liquid at the meter, using the average meter run temperature
- $CPLm_{run}$  is the correction factor for the effect of pressure on the liquid at the meter, using the average meter run pressure

### Volume K-factor (pls/m3)

$$KFm_{run} = \frac{PC_{run} \times CTLm_{run} \times CPLm_{run}}{GSVp_{run}}$$

where:

- $PC_{run}$  is the run pulse count (pls)
- $CTLm_{run}$  is the correction factor for the effect of temperature on the liquid at the meter, using the average meter run temperature
- $CPLm_{run}$  is the correction factor for the effect of pressure on the liquid at the meter, using the average meter run pressure
- $GSVp_{run}$  is the prover gross standard volume (m<sup>3</sup>)

### Meter Factor

$$MF = \frac{GSVp_{run}}{ISVm_{run}}$$

where:

- $GSVp_{run}$  is the prover gross standard volume (m<sup>3</sup>)
- $ISVm_{run}$  is the meter indicated standard volume (m<sup>3</sup>)

### Prover Volume Flowrate (m3/h)

$$VFRp_{run} = \frac{GSVp_{run}}{\Delta t \times CTLm_{run} \times CPLm_{run}} \times 3600$$

where:

- $GSVp_{run}$  is the prover gross standard volume (m<sup>3</sup>)
- $CTLm_{run}$  is the correction factor for the effect of temperature on the liquid at the meter, using the average meter run temperature
- $CPLm_{run}$  is the correction factor for the effect of pressure on the liquid at the meter, using the average meter run pressure
- $\Delta t$  is the average pass flight time (s)

## B.2.11.8 Formulae: Mass Prover Calculations

### Prover Gross Volume (m3)

$$GVp_{run} = BV \times CTSp_{run} \times CPSp_{run}$$

where:

$BV$	is the entered volume for the prover at standard conditions
$CTSp_{run}$	is the correction factor for the effect of temperature on the steel at the prover, using the average prover run temperature
$CPSp_{run}$	is the correction factor for the effect of pressure on the steel at the prover, using the average prover run pressure

### Prover Mass (kg)

$$Mp_{run} = GVp_{run} \times \text{Density}$$

where:

$GVp_{run}$  is the prover gross volume (m<sup>3</sup>)

$Density$  is the density at prover conditions (kg/m<sup>3</sup>)

### Meter Mass (kg)

$$Mm_{run} = \frac{PC_{run}}{KFm_{run}}$$

where:

$PC_{run}$  is the run pulse count (pls)

$KFm_{run}$  is the meter K-factor (pls/kg)

### Meter Factor

$$MF = \frac{Mp_{run}}{Mm_{run}}$$

where:

$Mp_{run}$  is the prover mass (kg)

$Mm_{run}$  is the meter mass (kg)

### Mass K-factor (pls/kg)

$$KFm_{run} = \frac{PC_{run}}{Mp_{run}}$$

where:

$PC_{run}$  is the run pulse count (pls)

$Mp_{run}$  is the prover mass (kg)

### Prover Mass Flowrate (kg/h)

$$MFRp_{run} = \frac{Mp_{run}}{\Delta t} \times 3600$$

where:

$Mp_{run}$  is the mass for the master meter (kg)

$\Delta t$  is the average pass flight time (s)

### B.2.11.9 K-factor Deviation

When the required number of consecutive good runs has been achieved, the program checks each individual run's K-factor (which make up the  $N$  consecutive good runs) to see how far it deviates from the average. If any run's K-factor deviates by more than the allowable limit then additional runs are performed and the test is repeated.

When all K-factors for the required runs fall within the deviation limit, then the prove is considered successful and a final average data is calculated. At the same time the program stores the single maximum deviation value (repeatability) of the good run K-factors as an indication of how well the prove fell within the deviation tolerance.

#### API Ch.4 Method 1 (default)

$$K_{dev} = \frac{(K_{avg} - K_{run})}{K_{avg}} \times 100$$

#### MX-MN/AVG

$$K_{dev} = \frac{(K_{max} - K_{min})}{K_{avg}} \times 100$$

#### MX-MN/MX+MN2

$$K_{dev} = \frac{(K_{max} - K_{min})}{(K_{max} + K_{min}) \div 2} \times 100$$

#### MX-MN/MN

$$K_{dev} = \frac{(K_{max} - K_{min})}{K_{min}} \times 100$$

#### MX-MN/MX\*MN

$$K_{dev} = \frac{(K_{max} - K_{min})}{(K_{max} \times K_{min})} \times 100$$

#### MX-AV/AV

$$K_{dev} = \frac{(K_{max} - K_{avg})}{K_{avg}} \times 100$$

#### AV-MN/AV

$$K_{dev} = \frac{(K_{avg} - K_{min})}{K_{avg}} \times 100$$

where:

$K_{dev}$  is the K-factor deviation (%)

$K_{avg}$  is the average K-factor of  $N$  consecutive good runs (pls/m<sup>3</sup>)

$K_{min}$  is the minimum K-factor of  $N$  consecutive good runs (pls/m<sup>3</sup>)

$K_{max}$  is the maximum K-factor of  $N$  consecutive good runs (pls/m<sup>3</sup>)

$K_{run}$  is the run K-factor being checked (pls/m<sup>3</sup>)



## Statistical

$$K_{dev} = 200 \times t_{N-1} \times \frac{S_{N-1}}{K_{avg} \times \sqrt{N}}$$

where:

$K_{dev}$  is the K-factor deviation (%)

$K_{avg}$  is the average K-factor of  $N$  consecutive good runs (pls/m<sup>3</sup>)

$t_{N-1}$  is the uncertainty band confidence level, which is a selectable value (95%, 99%, 99.5%, or a user-defined value). NORSOK requires this method (using the student-t distribution) at a recommended value of 95%. API MPMS Ch.4.8 also recommends 95%.

$S_{N-1}$  is the standard deviation of K-factor of  $N$  consecutive good runs (pls/m<sup>3</sup>)

### B.2.11.10 Meter Factor Deviation Tests

This section defines Meter Factor Deviation tests.

#### Calculated Meter Factor versus Initial Base Meter Factor

$$\% \text{ Deviation Test 1} = \frac{(\text{MFCP}_{\text{FRN}} - \text{Initial Base Meter Factor})}{(\text{Initial Base Meter Factor})} \times 100$$

where:

$\text{MFCP}_{\text{FRN}}$  is the calculated meter factor from current prove at normal flow rate.

Maximum deviation of  $\pm 0.25$  %.

#### Calculated Meter Factor versus Average of Previous Historical Meter Factors

$$\% \text{ Deviation Test 2} = \frac{(\text{MFCP}_{\text{FRN}} - \text{Average of Previous Meter Factors})}{(\text{Average of Previous Meter Factors})} \times 100$$

where:

$\text{MFCP}_{\text{FRN}}$  is the calculated meter factor from current prove at normal flow rate.

Maximum deviation of  $\pm 0.1$  %.

## B.3 Master Meter Prover – Gas and Liquid

The primary function of the Master Meter is to provide an accurate "meter factor" value for the proving stream. The S600+ then uses this value to calibrate all other meters.

The proving stream receives pulses from its meter and generates a pulse train output, which represents the number of pulses received. The Master Meter counts these pulses during a proof run and also counts the pulses from its own meter (the master). When the proof run completes, the S600+ calculates a Meter Factor for the stream, based on the Master Meter's Meter Factor and the ratio of the correct stream output pulse count to the Master Meter's turbine pulse count.



**Caution** It is extremely unlikely that any one S600+ configuration would contain all the settings discussed in this section. For that reason, several sample configurations demonstrate the settings.

---

Two components enable you to control the prove:

- **Prove sequence**, a station-based function which sets up the prove environment, and
- **Run control**, a prover-based function which drives the prover hardware, counts pulses, and performs the K-factor calculations.

Following a successful prove, the system verifies the stream normal flow rate value:

- If the normal flow rate is set to a value greater than zero (**Aramco-style linearisation**), the run control waits for a predefined amount of time for you to reject the current prove results. If a prove is rejected, the proving report is annotated as "ABORTED". If the time-out elapses, the prove sequence downloads the prove results to the stream being proved and the data is automatically used in the subsequent calculations.
- If the normal flow rate is zero (**non-Aramco-style linearisation**), the prove sequence downloads the prove results to the stream being proved, but does not use the data until it is accepted either locally at the S600+ or via a supervisory computer.

When the prove runs complete, the sequence offers you the option of re-running the prove or terminating, at which point (if configured) the sequence restores the valves to their pre-prove state.

---

**Notes:**

- Aramco-style linearisation is **only** applicable to Liquid Master Meter proving. Gas Master Meter proving will always use the non-Aramco style linearisation.
- The prove sequence downloads both a K-factor and a meter factor. Applications typically use the original K-factor from the meter calibration report and update the meter factor, which may be a fixed value or derived from a linearisation process. Alternately, the meter factor can remain unchanged and the K-factor (fixed or linearised) updated.
- The meter factor deviation tests and the historical meter factor database are **only** applicable to Liquid Master Meter proving.

- The meter factor deviation tests and the historical meter factor database are only supported for "local" streams (part of the same configuration with the prover), if you configure the stream normal flow rate to a value greater than zero and you select "Product Table with History" when you create your configuration.
- You define a ticket as Official or Unofficial when you configure a prove. This selection applies to both the Aramco-style and non-Aramco-style linearisation.

Following an **Official** prove, the prove sequence is determined by the Aramco / non-Aramco style linearisation selection.

Following the **Unofficial** prove, the prove sequence does not download the prove results to the stream being proved. This is typically used to determine an approximate K-Factor / Meter Factor before an official prove takes place or when maintenance activities are being performed on the site.

The Official/Unofficial selection displays in the report header.

### B.3.1 Master Meter/Stream combinations

The following tables show the supported liquid and gas Master Meter / Stream combinations:

Table B-21. Master Meter/Stream Combinations – Liquid

Liquid					
		Stream Meter			
		Turbine (V)	USM (V)	Coriolis (V)	Coriolis (M)
Master Meter	Turbine (V)	Yes	Yes	Yes	Yes
	USM (V)	Yes	Yes	Yes	Yes
	Coriolis (V)	Yes	Yes	Yes	Yes
	Coriolis (M)	No	No	No	Yes

**Notes:**

1. (V) represents volume pulse-based meter input
2. (M) represents mass pulse-based meter input

Table B-22. Master Meter/Stream Combinations – Gas

Gas					
		Stream Meter			
		Turbine (V)	USM (V)	Coriolis (V)	Coriolis (M)
Master Meter	Turbine (V)	Yes	Yes*	Yes*	No
	USM (V)	Yes*	Yes	Yes	No
	Coriolis (V)	Yes*	Yes	Yes	No
	Coriolis (M)	No	No	No	No

**Notes:**

1. (V) represents volume pulse-based meter input
2. (M) represents mass pulse-based meter input

3. AGA6 Gas Master Metering is based on Volume comparison
4. Coriolis Meter must be configured to provide volume not mass flow rate
- \*. This combination needs the Master Meter and Stream Meter in separate stations.

### B.3.2 Inputs/Outputs

For master meter proving the S600+ requires the following hardware:

- A CPU module (P152+)
- An I/O module (P144)
- A Prover module (P154)

**Inputs** Master meter proving normally has the following inputs:

Prover Pressure	4-20mA ADC
Prover Temperature	4-20mA PRT
Master Meter Pulses	Pulse Input
Stream Raw Pulses	Raw Pulse Input
	<b>Note:</b> Pulse input must be on Prover module (P154).
Prove Enable Status	Digital Input

**Outputs** Master meter proving has no outputs.

### B.3.3 Communications

Using the Modbus protocol, a slave link provides communications with the stream flow computers.

- To set up the link at the prover (which is the master), select **Tech/Engineer > Communications > Assignment > Prover Master Lin > Seq Enable.**
- To set up the Modbus address, select **Tech/Engineer > Communications > Assignment > Prover Master Lin > Seq Addr.**

Prover/Stream Link	Default Setting
Modbus RTU Master	Serial RS485 - Comm 5
Prover/Stream Link	9600 8 bits No Parity 1 stop bit Address = 1 (front panel)

- To set up the link at the stream (which is the slave), select **Tech/Engineer > Communications > Assignment > Next > Prover Slave Lin.**

---

**Note:** You can reset the ports, baud rate, number of bits, and parity values through the S600+'s front panel.

---

### B.3.4 Pulse Measurement

The primary function of the prover is to calculate an accurate K-factor

or meter factor value for the meter under prove. The master meter does this by comparing pulses from the stream meter with those from the master meter.

The stream flow computer receives pulses from its meter and transmits a pulse train output ('Raw Pulse Output') which represents the number of pulses received, including bad pulse correction. The prove sequence commands the selected stream to turn on its 'Raw Pulse Output', which allows the prover computer to monitor the pulses from the meter. The prover counts pulses during a proof run, and corrects the count for temperature and pressure.

During the proof run the prover also counts the pulses received from its own master meter and the count is corrected for temperature and pressure.

When the proof run completes, the prover calculates the stream's K-factor from the master meter K-factor and the ratio of the corrected stream output pulse count and the master meter pulse count.

For a master meter prove, a run's duration is determined by counting a set number of pulses (typically 10000), by the flow for a set volume or mass of liquid, or by the flow of a liquid for a set period of time.

---

**Note:** The electrical diagram for the Prover module shows a Raw Pulse Output, but this is not available. You cannot use the Raw Pulse Output to pass pulses input to the Prover module to the Raw Pulse Input.

---

**Pulse Gating** The Prover module independently and synchronously snapshots and counts the master meter pulses together with the raw pulse inputs from the meter under prove.

**Pulse Interpolation** Use pulse interpolation when the pulse count is low (typically less than 10,000 pulses per run).

For master metering proving, you can use a Pulse Interpolation Module (PIM) and enter an interpolation factor corresponding to the PIM setting into the prover S600+ using a keypad.

A pulse lock lost digital input is provided to indicate whether the PIM pulses are valid. The input is active when the PIM output is considered good.

### B.3.5 Prove Sequence and Control

Two components enable you to control the prove:

- **Prove sequence**, a station-based function which sets up the prove environment, and
- **Run control sequence**, a prover-based function which drives the hardware, counts pulses, and performs the K-factor and meter factor calculations.

The S600+'s front panel display provides the following commands you can use to control and monitor the two prove control tasks (**Operator > Station > Sequence Ctl**):

Display	Description
SEQ CTL	Operator commands for sequence control (outer loop)
SEQ STREAM NO.	Enter the designated stream number to be proved. Note: For local streams, this is the logical stream number. For remote streams, this is the slave number in the Modbus master map. For example, if the first slave has a Modbus address of 22, this is stream 1. If the second slave in the master map has an address of 33, this is stream 2.
SEQ STAGE INDEX	Shows current sequence stage as the sequence progresses.
SEQ STAGE PREV	Indicates the sequence stage immediately prior to the current stage. If an abort occurs, use this value to help identify the source of the abort.
SEQ ABORT INDEX	In the event of a sequence error, an abort reason index displays here.
RUN CTL	Operator commands for proof run (inner loop)
Run permit	Interlock required for starting proof run.
Run stage index	Shows current proof run stage as the sequence progresses.
Run abort index	In the event of a proof run sequence error, an abort reason index displays here.

Following a successful prove, the system verifies the stream normal flow rate value:

- If the normal flow rate is set to a value greater than zero (**Aramco-style linearisation**), the run control waits for a predefined amount of time for you to reject the current prove results. If a prove is rejected, the proving report is annotated as "ABORTED". If the time-out elapses, the prove sequence downloads the prove results to the stream being proved and the data is automatically used in the subsequent calculations.
- If the normal flow rate is zero (**non-Aramco-style linearisation**), the prove sequence downloads the prove results to the stream being proved, but does not use the data until it is accepted either locally at the S600+ or via a supervisory computer.

You then have two options for accepting the prove results:

- If you select **ACCEPT**, the currently running batch is retroactively adjusted with the new factor.
- If you select **ACCEPT NO ADJUST**, no adjustment is performed on the currently running batch.

### B.3.5.1 Default Prove Sequence Stages

The prover sequence functions in stages. *Table B-23* shows the default stages for a typical application's normal, reprove, and abort situations.

If an abort occurs either automatically or by operator command then the prove sequence stage changes to Aborted. No further action is taken until the computer receives either a Continue command to initiate a re-prove or a Terminate command to finish the sequence.

*Table B-23. Default Prove Sequence Stages*

Stage	Display	Description
0	IDLE	Halted: idle, await Start command
1	INITIALISE	Initialise
2	PULSES ON	Turn proving stream pulses on
16	PRV FLOW/T/P STAB	Hold stable temperature, pressure and flowrate
18	PROOF RUN	Perform proof runs (execute Run Control stages)
19	KF DOWNLOAD	K-factor and data download
20	AWAIT REPROVE	Halted: prove runs complete, await Continue/Terminate command
26	ABORTED STAGE	Halted: sequence aborted, await Continue/Terminate command
<b>Continue (Reprove)</b>		
29	RE STAB CHECKS	Hold stable temperature, pressure and flowrate
18	PROOF RUN	Perform proof runs (execute Run Control stages)
<b>Terminate</b>		
25	PS PULSES OFF	Turn proving stream raw pulses off
30	TERMINATE	Terminate (return to idle)

### B.3.5.2 Complete Sequence Stage Descriptions

*Table B-24* shows all the stages of a prove sequence.

*Table B-24. Complete Prove Sequence Stages*

Stage	Title	Description
0	Idle	Wait for a command to start the sequence, then proceed to stage 1 (Validate and Initialise).
1	Validate + Initialise	<p>Verify:</p> <ul style="list-style-type: none"> <li>▪ The proving stream is flowing.</li> <li>▪ The proving stream is not in maintenance mode.</li> <li>▪ Telemetry to the proving stream is OK.</li> <li>▪ The prove permit state (run control status) is OK.</li> </ul> <p>Initialise:</p> <ul style="list-style-type: none"> <li>▪ Copy the proving stream meter variables into the proving set.</li> <li>▪ Copy the product stream product data into the proving set.</li> <li>▪ Initialise proof run date (via Initialise command to run control task).</li> <li>▪ Determine required proof flowrate from current rate (snapshot) or preset flowrate.</li> <li>▪ Save all FCV settings.</li> </ul> <p>Proceed to stage 2 (Pulses On).</p>

<b>Stage</b>	<b>Title</b>	<b>Description</b>
<b>2</b>	<b>Pulses On</b>	<p>Command all online streams to turn pulses off                      Command proving stream to turn pulses on                      Wait for pulses to be aligned                      Proceed to stage 3 (Prover FCV Initialise)                      Abort:</p> <ul style="list-style-type: none"> <li>▪ If an abort command is issued.</li> <li>▪ If proving stream telemetry fails.</li> <li>▪ If prove permit state (run control status) is off.</li> <li>▪ If no flow at proving stream.</li> <li>▪ If proving stream raw pulse output is not switched on.</li> <li>▪ If proving stream is in maintenance mode.</li> <li>▪ If peer status is not duty.</li> </ul>
<b>3</b>	<b>Prover FCV initialise</b>	<p>Set prover FCV manual output to initial output                      Set prover FCV mode to manual                      Set proving stream FCV tracking on                      Set proving stream FCV mode to manual                      Proceed to stage 4 (Open prover outlet)                      Abort:</p> <ul style="list-style-type: none"> <li>▪ If an abort command is issued.</li> <li>▪ If proving stream telemetry fails.</li> <li>▪ If prove permit state (run control status) is off.</li> <li>▪ If no flow at proving stream.</li> <li>▪ If proving stream raw pulse output is not switched on.</li> <li>▪ If proving stream is in maintenance mode.</li> <li>▪ If peer status is not duty.</li> </ul>
<b>4</b>	<b>Prover open outlet</b>	<p>Command Prover Outlet Valve to open                      Wait for valve to reach position                      Proceed to stage 5 (Non-proving stream close prover inlet)                      Abort:</p> <ul style="list-style-type: none"> <li>▪ If an abort command is issued.</li> <li>▪ If proving stream telemetry fails.</li> <li>▪ If prove permit state (run control status) is off.</li> <li>▪ If no flow at proving stream.</li> <li>▪ If proving stream raw pulse output is not switched on.</li> <li>▪ If proving stream is in maintenance mode.</li> <li>▪ If peer status is not duty.</li> <li>▪ If the valve fails to reach position.</li> </ul>
<b>5</b>	<b>Non-proving stream close prover inlet</b>	<p>Command non-proving streams Prover Inlet Valves to close                      Wait for valves to reach position                      Proceed to stage 6 (Proving stream open prover inlet)                      Abort:</p> <ul style="list-style-type: none"> <li>▪ If an abort command is issued.</li> <li>▪ If proving stream telemetry fails.</li> <li>▪ If prove permit state (run control status) is off.</li> <li>▪ If no flow at proving stream.</li> <li>▪ If proving stream raw pulse output is not switched on.</li> <li>▪ If proving stream is in maintenance mode.</li> <li>▪ If peer status is not duty.</li> <li>▪ If the valves are not correctly aligned.</li> <li>▪ If the valve fails to reach position.</li> </ul>



<b>Stage</b>	<b>Title</b>	<b>Description</b>
<b>6</b>	<b>Proving stream open prover inlet</b>	<p>Command proving streams Prover Inlet Valve to open            Wait for valve to reach position            Proceed to stage 7 (Proving stream close stream outlet)</p> <p>Abort:</p> <ul style="list-style-type: none"> <li>▪ If an abort command is issued.</li> <li>▪ If proving stream telemetry fails.</li> <li>▪ If prove permit state (run control status) is off.</li> <li>▪ If no flow at proving stream.</li> <li>▪ If proving stream raw pulse output is not switched on.</li> <li>▪ If proving stream is in maintenance mode.</li> <li>▪ If peer status is not duty.</li> <li>▪ If the valves are not correctly aligned.</li> <li>▪ If the valve fails to reach position.</li> </ul>
<b>7</b>	<b>Proving stream close stream outlet</b>	<p>Command proving streams Outlet Valve to close            Wait for valve to reach position            Proceed to stage 9 (Non-proving stream FCVS track)</p> <p>Abort:</p> <ul style="list-style-type: none"> <li>▪ If an abort command is issued.</li> <li>▪ If proving stream telemetry fails.</li> <li>▪ If prove permit state (run control status) is off.</li> <li>▪ If no flow at proving stream.</li> <li>▪ If proving stream raw pulse output is not switched on.</li> <li>▪ If proving stream is in maintenance mode.</li> <li>▪ If peer status is not duty.</li> <li>▪ If the valves are not correctly aligned.</li> <li>▪ If the valve fails to reach position.</li> </ul>
<b>8</b>	<b>Not used</b>	
<b>9</b>	<b>Non-proving stream FCVS track</b>	<p>Set FCV for non-proving streams to tracking            Proceed to stage 10 (Non-proving stream flow balance)</p> <p>Abort:</p> <ul style="list-style-type: none"> <li>▪ If an abort command is issued.</li> <li>▪ If proving stream telemetry fails.</li> <li>▪ If prove permit state (run control status) is off.</li> <li>▪ If no flow at proving stream.</li> <li>▪ If proving stream raw pulse output is not switched on.</li> <li>▪ If proving stream is in maintenance mode.</li> <li>▪ If peer status is not duty.</li> <li>▪ If the valves are not correctly aligned.</li> </ul>

Stage	Title	Description
10	<b>Non-proving stream flow balance</b>	<p>Enable flow balancing for non-proving streams</p> <p>Flow error = proving stream flowrate - (selected proof flowrate + offset).</p> <p>If the error is too low then:</p> <ul style="list-style-type: none"> <li>▪ If there are no on-line streams then go to abort stage.</li> <li>▪ Turn down value = abs (error / no. of on line none proving streams).</li> <li>▪ For each on line proving stream, new setpoint = current rate - turn down.</li> </ul> <p>If all new set points (for each stream) are within the low flow range then download the new set points and delay for adjustment prior to rechecking the flow error.</p> <p>If any new set point is less than the low flow range then go to stage 12 (operator close)</p> <p>If the error is too high then:</p> <ul style="list-style-type: none"> <li>▪ If there are no on-line streams then go to abort stage.</li> <li>▪ Turn up value = error / no. of on line none proving streams.</li> <li>▪ For each on line proving stream, new setpoint = current rate + turn up.</li> </ul> <p>If all new set points (for each stream) are within the high flow range then download the new set points and delay for adjustment prior to rechecking the flow error.</p> <p>If any new set point is higher than the low flow range then go to stage 13 (operator open).</p> <p>Proceed to stage 14 if the error is within tolerance (Non-proving stream FCV manual).</p> <p>Abort:</p> <ul style="list-style-type: none"> <li>▪ If an abort command is issued.</li> <li>▪ If proving stream telemetry fails.</li> <li>▪ If prove permit state (run control status) is off.</li> <li>▪ If no flow at proving stream.</li> <li>▪ If proving stream raw pulse output is not switched on.</li> <li>▪ If proving stream is in maintenance mode.</li> <li>▪ If peer status is not duty.</li> <li>▪ If the valves are not correctly aligned.</li> <li>▪ If the valve fails to reach position.</li> <li>▪ If flow balance is not achieved (timeout / hold fails).</li> </ul>
11	<b>Not used</b>	
12	<b>Close suspend</b>	<p>Flow balancing – wait for operator to close stream</p> <p>Return to flow balancing stage 10 if continue command issued</p> <p>Abort:</p> <ul style="list-style-type: none"> <li>▪ If an abort command is issued.</li> <li>▪ If proving stream telemetry fails.</li> <li>▪ If prove permit state (run control status) is off.</li> <li>▪ If no flow at proving stream.</li> <li>▪ If proving stream raw pulse output is not switched on.</li> <li>▪ If proving stream is in maintenance mode.</li> <li>▪ If peer status is not duty.</li> <li>▪ If the valves are not correctly aligned.</li> <li>▪ If the valve fails to reach position.</li> <li>▪ If flow balance is not achieved (timeout / hold fails).</li> </ul>

<b>Stage</b>	<b>Title</b>	<b>Description</b>
<b>13</b>	<b>Open suspend</b>	<p>Flow balancing – wait for operator to open stream Return to flow balancing stage 10 if continue command issued Abort:</p> <ul style="list-style-type: none"> <li>▪ If an abort command is issued.</li> <li>▪ If proving stream telemetry fails.</li> <li>▪ If prove permit state (run control status) is off.</li> <li>▪ If no flow at proving stream.</li> <li>▪ If proving stream raw pulse output is not switched on.</li> <li>▪ If proving stream is in maintenance mode.</li> <li>▪ If peer status is not duty.</li> <li>▪ If valves are not correctly aligned.</li> <li>▪ If the valve fails to reach position.</li> <li>▪ If flow balance is not achieved (timeout / hold fails).</li> </ul>
<b>14</b>	<b>Non-proving stream FCVS manual</b>	<p>Set all non-proving stream FCV tracking on Set all non-proving stream FCV mode to manual Proceed to stage 15 (Prover flowrate stability) Abort:</p> <ul style="list-style-type: none"> <li>▪ If an abort command is issued.</li> <li>▪ If proving stream telemetry fails.</li> <li>▪ If prove permit state (run control status) is off.</li> <li>▪ If no flow at proving stream.</li> <li>▪ If proving stream raw pulse output is not switched on.</li> <li>▪ If proving stream is in maintenance mode.</li> <li>▪ If peer status is not duty.</li> <li>▪ If the valves are not correctly aligned.</li> </ul>
<b>15</b>	<b>Prover flowrate stability</b>	<p>Set prover FCV to selected prove flow rate + offset Set prover FCV mode to auto Set prover FCV tracking to on Hold proving stream flow rate within tolerance for a user configurable time Proceed to stage 16 (Temperature / Pressure Stability) Abort:</p> <ul style="list-style-type: none"> <li>▪ If an abort command is issued.</li> <li>▪ If proving stream telemetry fails.</li> <li>▪ If prove permit state (run control status) is off.</li> <li>▪ If no flow at proving stream.</li> <li>▪ If proving stream raw pulse output is not switched on.</li> <li>▪ If proving stream is in maintenance mode.</li> <li>▪ If peer status is not duty.</li> <li>▪ If the valves are not correctly aligned.</li> <li>▪ If stability not achieved.</li> </ul>

Stage	Title	Description
16	<b>Synchronise with Run Control (Temperature / pressure stability)</b>	<p>Hold stability for a user-configurable time                      Proceed to stage 18 (Proof runs)                      Abort:</p> <ul style="list-style-type: none"> <li>▪ If an abort command is issued.</li> <li>▪ If proving stream telemetry fails.</li> <li>▪ If prove permit state (run control status) is off.</li> <li>▪ If no flow at proving stream.</li> <li>▪ If proving stream raw pulse output is not switched on.</li> <li>▪ If proving stream is in maintenance mode.</li> <li>▪ If peer status is not duty.</li> <li>▪ If the valves are not correctly aligned.</li> <li>▪ If stability not maintained.</li> </ul>
17	<b>Not used</b>	
18	<b>Synchronise with Run Control (Proof runs)</b>	<p>Start the prove runs (via Start command to run control task).                      On success proceed to stage 19 (KF download)                      Abort:</p> <ul style="list-style-type: none"> <li>▪ If a run fails (such as a timeout for a sphere switch).</li> <li>▪ If an abort command is issued.</li> <li>▪ If proving stream telemetry fails.</li> <li>▪ If prove permit state (run control status) is off.</li> <li>▪ If no flow at proving stream.</li> <li>▪ If proving stream raw pulse output is not switched on.</li> <li>▪ If proving stream is in maintenance mode.</li> <li>▪ If peer status is not duty.</li> <li>▪ If the valves are not correctly aligned.</li> </ul>
19	<b>K-factor Download</b>	<p>Copy proof K-factor, meter factor, flow rate, and frequency into proving stream data points for subsequent telemetry download.  <b>Notes:</b></p> <ul style="list-style-type: none"> <li>▪ The stream metering calculations do not use these until commanded separately.</li> <li>▪ If the historical meter factor option is enabled then the historical meter factors and deviations arrays are also copied.</li> </ul> <p>Proceed to stage 20 (Await reprove)</p>
20	<b>Await reprove</b>	<p>Go to stage 22 (Proving stream open stream outlet) if the Terminate or abort command is issued.                      Go to stage 29 (Stability Checks) if Continue (Reprove) command is issued.</p>
21	<b>Not used</b>	
22	<b>Proving stream open stream outlet</b>	<p>Command proving stream Outlet Valve to open                      Wait for valve to reach position                      Proceed to stage 23 (Proving stream close prover inlet)                      Abort:</p> <ul style="list-style-type: none"> <li>▪ If an abort command is issued.</li> <li>▪ If proving stream telemetry fails.</li> <li>▪ If prove permit state (run control status) is off.</li> <li>▪ If no flow at proving stream.</li> <li>▪ If proving stream raw pulse output is not switched on.</li> <li>▪ If proving stream is in maintenance mode.</li> <li>▪ If peer status is not duty.</li> <li>▪ If valve fails to reach position.</li> </ul>

Stage	Title	Description
23	<b>Proving stream close prover inlet</b>	<p>Command proving stream Prover Inlet Valve to close            Wait for valve to reach position            Proceed to stage 24 (Restore FCV)</p> <p>Abort:</p> <ul style="list-style-type: none"> <li>▪ If an abort command is issued.</li> <li>▪ If proving stream telemetry fails.</li> <li>▪ If prove permit state (run control status) is off.</li> <li>▪ If no flow at proving stream.</li> <li>▪ If proving stream raw pulse output is not switched on.</li> <li>▪ If proving stream is in maintenance mode.</li> <li>▪ If peer status is not duty.</li> <li>▪ If the valve fails to reach position.</li> </ul>
24	<b>Restore FCVS</b>	<p>Reset FCV's to previous (pre-prove) settings as noted in stage 1            Proceed to stage 25 (Proving stream pulses off)</p> <p>Abort:</p> <ul style="list-style-type: none"> <li>▪ If an abort command is issued.</li> <li>▪ If proving stream telemetry fails.</li> <li>▪ If prove permit state (run control status) is off.</li> <li>▪ If no flow at proving stream.</li> <li>▪ If proving stream raw pulse output is not switched on.</li> <li>▪ If proving stream is in maintenance mode.</li> <li>▪ If peer status is not duty</li> </ul>
25	<b>Proving stream pulses off</b>	<p>Command proving stream to turn pulses off.            Wait for the pulses to be turned off            Proceed to stage 1</p> <p>Abort:</p> <ul style="list-style-type: none"> <li>▪ If an abort command is issued.</li> <li>▪ If proving stream telemetry fails.</li> <li>▪ If prove permit state (run control status) is off.</li> <li>▪ If no flow at proving stream.</li> <li>▪ If proving stream is in maintenance mode.</li> <li>▪ If peer status is not duty</li> </ul>
26	<b>Aborted stage</b>	<p>An abort condition has occurred.            Go to the next relevant stage if the Terminate command is issued.            Go to stage 29 (Stability Checks) if Continue (Reprove) command is issued.</p>
27	<b>Not used</b>	
28	<b>Not used</b>	
29	<b>Synchronise with Run Control (Stability checks)</b>	<p>Wait to achieve stability (via Stabilise command to run control task) for temperatures, pressure rate of change.            Upon achieving stability, wait for stability to be held for a user-configurable time.            Proceed to the stage 18 (Proof runs).</p>
30	<b>Terminate</b>	<p>Ensure the run control sequence terminates.            Return to stage 1 (Idle).</p>
31 to 40	<b>User Stages</b>	<p>Requires the implementation of the expseq.txt file and a logicalc to perform any specific functionality.</p>
41	<b>Not used</b>	
42	<b>User Comms Suspend 1</b>	<p>Suspends the prover / stream communications.            Requires the implementation of the expseq.txt file and a logicalc to perform any specific functionality.</p>

Stage	Title	Description
43	<b>User Comms Normal 1</b>	Re-enables the prover / stream communications. Requires the implementation of the expseq.txt file and a logicalc to perform any specific functionality.
44	<b>User Comms Suspend 2</b>	Suspends the prover / stream communications. Requires the implementation of the expseq.txt file and a logicalc to perform any specific functionality.
45	<b>User Comms Normal 2</b>	Re-enables the prover / stream communications. Requires the implementation of the expseq.txt file and a logicalc to perform any specific functionality.

### B.3.5.3 Prove Sequence Abort Index

Table B-25 shows the abort values for a prove sequence.

Table B-25. Prove Sequence Abort Index

Value	Display	Description
1	OP ABORT	Operator Requested Abort
2	Not Used	
3	PS TELEM FAIL	Proving Stream Telemetry Fail
4	RUN CTL BUSY	Run Control Task Busy
5	METER NO FLOW	No Flow at Meter
6	RUN CTL ABORT	Run Control Task Aborted
7	ILLEGAL PULSES	More than one stream has raw pulses enabled.
8	ANY TELEM FAIL	Non Proving Stream Telemetry Fail
9	NPS PRV I-VLV OPEN	Non Proving Stream Prover Valve Not Closed
10	PS PRV I-VLV CLOSED	Proving Stream Prover Offtake Valve Not Open
11	PS STR O-VLV OPEN	Proving Stream Outlet Valve Not Closed
12	PRV I-VLV CLOSED	Prover Inlet Valve Not Open
13	PRV O-VLV CLOSED	Prover Outlet Valve Not Open
14	PS IN MAINT	Proving Stream Is In Maintenance Mode
15	FBAL TIMEOUT	Flow Balance Timeout
16	FBAL NO NPS ON LINE	Flow Balance Error - No Non Proving Streams On-line
17	FBAL NO NPS IN AUTO	Flow Balance Error - No Non Proving Streams In Auto
18	FBAL HOLD FAIL	Flow Balance Error - Stability Not Achieved
19	PS I-ISL-VLV CLOSED	Proving Stream Inlet Isolation Valve Not Open
20	PS O-ISL-VLV CLOSED	Proving Stream Header Isolation Valve Not Open
21	PS P-ISL-VLV CLOSED	Proving Stream Prover Isolation Valve Not Open
22	PEER STATUS STANDBY	Unit is in standby mode when peer-to-peer is configured

### B.3.6 Prover Run Control Stages

The Run Control sequence is specific to the type of prover (such as a ball prover, a compact prover, or a master meter). The Run Control sequence initiates the prove runs and performs the calculations that produce a K-factor and meter factor when the runs are completed.

Normally the sequence runs when commanded by the Prove Sequence at stage 18 (Perform Proof Runs). However, you can initiate it from the S600+ front panel display or (by using custom control) from elsewhere.

The Prover Run sequence below shows the default stage sequences for a typical master meter prove.

Table B-26. Prover Run Control Stages

Stage	Display	Description
0	IDLE	Halted: idle
1	INITIALISE	Initialise run data
2	AWAIT STAB CMD	Halted: await Stabilise command
3	WAIT STAB	Wait until stability is achieved
5	AWAIT RUN CMD	Halted: await start runs command
6	START RUN	Start the pulse counters
7	COUNT PULSES	Count the pulses
8	RUN CALCS	Perform run calculations
9	AVG CALCS	Perform run average calculations
12	STD POST RUN	No action
10	STD RPT CHECKS	Perform repeatability checks (if success go to stage 14)
13	CHECK RUNS EXCEEDED	Check runs exceeded (if yes go to stage 11 else stage 6)
14	FINAL AVG	Perform final average calculations
15	MF DEVIATION CHECKS	Perform meter factor deviation checks. <b>Note:</b> This stage applicable to Liquid Master Meter Proving and is performed <b>only</b> if you configure the meter normal flow to a value greater than zero ( <b>Aramco-style linearisation</b> ) and you select "Product Table with History" when you create your configuration.
16	WAIT REJECT COMMAND	Allow a time-out for rejecting the current prove. If the time-out elapses go to the next stage. <b>Note:</b> This stage applicable to Liquid Master Meter Proving and is performed <b>only</b> if you configure the meter normal flow to a value greater than zero ( <b>Aramco-style linearisation</b> ).
17	REPORT GENERATION	Print the proof report.
11	FINAL	Halted: final – await Terminate/Reprove command.

You can also enable user stages on the PC Setup Run Data screen. These invoke a LogiCalc which you can edit to provide user-specific logic as the prove progresses. Example LogiCalcs are included in the C:\Users\\Config600 3.3\lclib\prover directory. Copy one of these to the C:\Users\\Config600 3.3\Configs\Project\LogiCalc directory so you edit it to be compatible with your configuration and then download it to the S600+ with the configuration.

**Note:** You can enable user stages by editing a configuration using the System Editor.

### B.3.6.1 Run Control Stage Description

Table B-27 shows all the stages of a Run Control sequence.

Table B-27. Master Meter Prover Run Control Stages

Run Stage	Description
-----------	-------------

Run Stage	Description
<b>0</b>	<p><b>Idle</b></p> <p>Wait for the Initialise command to start the Run Control sequence.            Proceed to next stage only if the prove is permitted (that is, if the Run Control stage is Idle or Final <b>and</b> the available signal is zero; normally, the available signal is assigned to a digital input which may be connected to a valve or a key-switch).</p>
<b>1</b>	<p><b>Initialise Run Data</b></p> <p>Zero down all run data and arrays.            Proceed to next stage.</p>
<b>2</b>	<p><b>Halted: Await Stabilise Command</b></p> <p>Wait for Stabilise command then proceed to next stage.            Abort:</p> <ul style="list-style-type: none"> <li>▪ If the prove is no longer permitted.</li> <li>▪ If the master meter number has changed.</li> <li>▪ If the Terminate command is issued.</li> </ul>
<b>3</b>	<p><b>Wait Until Stability Is Achieved</b></p> <p>Proceed to next stage if stability override is on.            Set stability wait timer running.            Continuously monitor deviations for:</p> <ul style="list-style-type: none"> <li>▪ meter pressure vs. prover pressure</li> <li>▪ meter temperature vs. prover temperature</li> </ul> <p>Continuously monitor (over 5-second periods) rates of change for:</p> <ul style="list-style-type: none"> <li>▪ prover pressure</li> <li>▪ prover temperature</li> <li>▪ meter flowrate</li> </ul> <p>Proceed to next stage when stability is achieved.            Abort:</p> <ul style="list-style-type: none"> <li>▪ If the prove is no longer permitted.</li> <li>▪ If the master meter number has changed.</li> <li>▪ If Terminate command is issued.</li> <li>▪ If stability wait timer expires.</li> </ul>
<b>4</b>	<p><b>Hold Stability For Entered Period</b></p> <p>Proceed to next stage if stability override is on.            Set stability hold timer running.            Repeat the stability checks from the previous stage to ensure stability is maintained for the given period.            Proceed to next stage when stability hold timer expires.            Abort:</p> <ul style="list-style-type: none"> <li>▪ If the prove is no longer permitted.</li> <li>▪ If the master meter number has changed.</li> <li>▪ If the Terminate command is issued.</li> <li>▪ If any of the stability checks fail.</li> </ul>
<b>5</b>	<p><b>Halted: Await Start Runs Command</b></p> <p>Wait for Start Runs command then proceed to next stage.            Abort:</p> <ul style="list-style-type: none"> <li>▪ If the prove is no longer permitted.</li> <li>▪ If the master meter number has changed.</li> <li>▪ If the Terminate command is issued.</li> </ul>
<b>6</b>	<p><b>Start Run</b></p> <p>Start the pulse counters.            Proceed to next stage.            Abort:</p> <ul style="list-style-type: none"> <li>▪ If the prove is no longer permitted.</li> <li>▪ If the master meter number has changed.</li> <li>▪ If the Terminate command is issued.</li> </ul>



Run Stage	Description
7	<p><b>Count Pulses</b></p> <p>Set flight timer running.            Count and monitor the pulses.            Average meter and prover data.            Check stability is maintained for duration of the prove run by repeating the stability checks from the wait stability stage.            Proceed to next stage when the required number of pulses has been counted, or the required volume/mass has been metered, or the specified run duration has elapsed.</p> <p>Abort:</p> <ul style="list-style-type: none"> <li>▪ If the prove is no longer permitted.</li> <li>▪ If the master meter number has changed.</li> <li>▪ If the Terminate command is issued.</li> <li>▪ If master meter K-factor equals 0.</li> <li>▪ If master meter and meter under prove bad pulse counts differ.</li> <li>▪ If pulse lock is lost (if PIM).</li> <li>▪ If flight timer expires.</li> </ul>
8	<p><b>Perform Run Calculations</b></p> <p>Based on data averaged during the run.            Proceed to next stage if calculations are all valid.            Abort if there is a calculation failure (such as K-factor out of range).</p>
9	<p><b>Perform Run Average Calculations</b></p> <p>Average the individual run data over the last <i>n</i> good runs and store the results.            Proceed to the next stage.</p>
10	<p><b>Perform Repeatability Checks</b></p> <p>If the required number of runs <b>has not</b> been performed then proceed to next stage.            If the required number of runs <b>has been</b> performed then check each of the last <i>n</i> run's K-factor against the average.            If each K-factor is <b>within</b> tolerance then proceed to the Await Reprove/Terminate stage (11).            If any K-factors are <b>outside</b> tolerance and the maximum number of runs has been exceeded then proceed to the Await Reprove/Terminate stage (11), otherwise proceed to the next stage.</p>
11	<p><b>Halted: Final - Await Terminate/Reprove Command</b></p> <p>End of prove. If:</p> <ul style="list-style-type: none"> <li>▪ Run control command is Initialise, proceed to Initialise stage 1 (Run Data)</li> <li>▪ Run control command is Terminate, proceed to stage 0 (Idle)</li> <li>▪ Run control command is Seat Sphere, proceed to the next stage (Seat Sphere).</li> </ul>
13	<p><b>Check Runs Exceeded</b></p> <p>Check the number of runs executed against the maximum allowed.            Proceed to the next stage.            Abort if the maximum runs have been exceeded.</p>
14	<p><b>Perform Final Average Calculations</b></p> <p>Calculate the final (average) K-factor and meter factor.            Proceed to the next stage.</p>

Run Stage	Description
<b>15</b>	<p><b>Perform Meter Factor Deviation Checks</b></p> <p>Perform tolerance tests (calculated meter factor versus meter factor: maximum deviation of 0.25% and calculated meter factor versus average of saved historical meter factors: maximum deviation of 0.1%).</p> <p>Only valid meter factors at normal flow rates are incorporated in the historical database. When the limits for either test exceed the meter factor they are not used for measurement and the corresponding meter factor at normal meter flow rate is not entered in the historical database. Proving reports are annotated as "ABORTED" with cause of failure stated.</p> <p>Proceed to stage 13 if any of the tolerance test fail.</p> <p>Proceed to the next stage.</p> <p><b>Note:</b> This stage is <b>only</b> applicable to Liquid Master Meter Proving and is performed <b>only</b> if you configure the meter normal flow rate to a value greater than zero (<b>Aramco-style linearisation</b>) and you select "Product Table with History" when you create your configuration.</p>
<b>16</b>	<p><b>Await for Current Prove to be Rejected</b></p> <p>You can reject the current prove results within a predefined time-out.</p> <p>Abort if the prove is rejected.</p> <p>Proceed to the next stage.</p> <p><b>Note:</b> This stage is performed <b>only</b> if you configure the meter normal flow to a value greater than zero (<b>Aramco-style linearisation</b>).</p>
<b>17</b>	<p><b>Print the Proof Report</b></p> <p>Proceed to stage 11.</p>

### B.3.6.2 Run Stage Abort Index

Following an abort the program displays a value in the Run Control abort index display.

*Table B-28. Run Stage Abort Index*

Value	Display	Description
0	NULL	Not used
1	OPERATOR	Operator abort
2	PC TIMEOUT	Not used
3	STAB WAIT	Temperature/Pressure/Flowrate wait stability timeout
4	STAB HOLD	Temperature/Pressure/Flowrate hold stability timeout
5	AVG CALC	Not used
6	RUN CALC	Error occurred when performing run calculations. For details refer to Run Stage Calc Index
7	RUNS EXCEEDED	Maximum number of runs exceeded
8	PLS LOCK LOST	Pulse interpolator module lock lost
9	IO FAIL	I/O module failed to respond to prove request
10	NULL DATA	Not used
11	KF/MF RANGE	K-f actor or meter factor out of range, even if alarms not

Value	Display	Description
		configured. To resolve, check the high and low limits for the meter factor, the K-factor, and pulse count objects.
12	UNAVAIL	Prover unavailable
13	TIMEOUT	Flight timeout
14	INVALID CONSTANTS	Master meter K-factor = 0 or selection option invalid
15	BAD PULSES	Master meter and meter under prove bad pulse counts differ
16	MM NO CHANGED	Master meter number changed during prove runs
17	INV CALC	Unsupported volume/mass calculations

### B.3.6.3 Run Stage Calculation Index

If a prover calculation fails, the program displays a value indicating the failed calculation in the Run Stage Index S600+ front panel display.

Table B-29. Run Stage Calculation Index

Value	Display	Description
0	IDLE	No calculation errors
11	FREQ	Calculation failed because flight time equaled 0
12	CPLP	The calculation to determine the correction factor for the effect of pressure on the liquid at the prover (CPLp) failed because of low density – applicable to <b>Liquid only</b>
13	CPLM	The calculation to determine the correction factor for the effect of pressure on the liquid at the meter (CPLm) failed because of low density – applicable to <b>Liquid only</b>
14	CTLP	The calculation to determine the correction factor for the effect of temperature on the liquid at the prover (CTLp) failed because of low density – applicable to <b>Liquid only</b>
15	CTLM	The calculation to determine the correction factor for the effect of temperature on the liquid at the meter (CTLm) failed because of low density – applicable to <b>Liquid only</b>
16	PRV GVOL	The calculation to determine the gross volume at the prover failed because the K-factor or the pulse count equaled 0
17	MTR GVOL	The calculation to determine the gross volume at the meter failed because the K-factor or the pulse count equaled 0
18	PRV SVOL	The calculation to determine the volume at standard conditions (SVOL) at the prover failed because of no error checks
19	MTR SVOL	The calculation to determine the volume at standard conditions (SVOL) at the meter failed because of no error checks
20	K-FACTOR	The calculation to determine K-factor failed because the value was outside low/high alarm limits
21	METER FACTOR	The calculation to determine meter factor failed because the value was outside low/high alarm limits
22	PRV FLOWRATE	The calculation to determine the flowrate at the prover failed because the flight time equaled 0
23	MTR FLOWRATE	The calculation to determine the flowrate at the meter failed because the flight time equaled 0
31	PRV PCF	The calculation to determine the pressure correction factor (PCF) at the prover failed.
32	PRV MASS	The calculation to determine the mass at the prover failed because the K-factor, pulse count, or pressure correction factor was 0
33	MTR MASS	The calculation to determine the mass at the meter failed because the K-factor, pulse count, or pressure correction factor was 0.
34	METER FACTOR	The calculation to determine meter factor failed because the value was outside low/high alarm limits

<b>Value</b>	<b>Display</b>	<b>Description</b>
35	PRV FLOWRATE	The calculation to determine the flowrate at the prover failed because the flight time equaled 0
36	MTR FLOWRATE	The calculation to determine the flowrate at the meter failed because the flight time equaled 0
37	K-FACTOR	The calculation to determine the K-factor failed because the value was outside low/high alarm limits

### B.3.7 Prove/Stream Data

The prover computer reads the following data from the stream under prove:

- Stream Temperature (in use)
- Stream Pressure (in use)
- Stream Standard Density (in use)
- Alpha Constant K0 – applicable to **Liquid only**
- Alpha Constant K1 – applicable to **Liquid only**
- Alpha Constant K2 – applicable to **Liquid only**
- Equilibrium Vapour Pressure – applicable to **Liquid only**
- Zf (Flowing Compressibility) applicable to **Gas only**
- Meter Factor (in use)
- K-factor (in use)
- CTSm (in use) – applicable to **Liquid only**
- CPSm (in use) – applicable to **Liquid only**
- Flowrate Minimum
- Flowrate Maximum
- FCV Setpoint
- FCV Output
- Reference Temperature
- Meter Density (in use)
- FCV Auto/Manual Status
- FCV Tracking Status
- Volume Correction Rounding Status
- Volume Correction Units Selection – applicable to **Liquid only**
- Volume Correction Product Type – applicable to **Liquid only**
- Volume Correction CPL Option – applicable to **Liquid only**
- Volume Correction Product Subtype – applicable to **Liquid only**
- Volume Correction Density Type – applicable to **Liquid only**
- K-factor Units
- Normal Meter Flow Rate – applicable to **Liquid only**
- Initial Base Meter Factor – applicable to **Liquid only**
- Initial Base Meter Factor Time Stamp – applicable to **Liquid only**
- Base Meter Factor Linearisation Points – applicable to **Liquid only**



# Config600 Configuration Software User Manual

```

10      0.000000    0.000000  0.000000    0.000000    0.00    0.00    0.0  0.000000
11      0.000000    0.000000  0.000000    0.000000    0.00    0.00    0.0  0.000000
12      0.000000    0.000000  0.000000    0.000000    0.00    0.00    0.0  0.000000
AVE     0.000000    0.000000  0.000000    0.000000    0.00    0.00    0.0  0.000000

```

```

CURRENT K-FACTOR      :      0.00 pls/m3
NEW K-FACTOR          :      0.00 pls/m3
NEW METER FACTOR      :      0.000000
REPEATABILITY         :      0.000000 %

```

```

=====
=====

```

```

=====
1                                     PROVING REPORT
Emerson Process Management
(0)OFFICIAL (0)UNOFFICIAL (0)ABORTED

```

```

LOCATION : AAAAAA          DATE/TIME : MM/DD/YYYY HH:MM:SS

```

```

METER MANUFACTURER: AAAAAA          PROVER MANUFACTURER: AAAAAA
METER MODEL:       AAAAAA          PROVER SERIAL NUMBER: AAAAAA
METER SERIAL NUMBER: AAAAAA
METER SIZE (mm):   0.000
NOMINAL K-FACTOR:  0.000
METER TAG NUMBER:  AAAAAA

```

```

PRIMARY FLOW COMPUTER: XX:XX:XX:XX:XX:XX

```

```

LIQUID: A CRUDE
OBSERVED DENSITY:  0.000 kg/m3 AT 0.00 Deg.C = 0.000 kg/m3 AT 0.000 Deg.C
TRIAL PULSES TOTAL PRESS      TEMP      TRIAL

```

TRIAL No.	PLUSES TOTAL	TOTAL TIME s	PRESS PROVER barg	METER barg	TEMP PROVER Deg.C	METER Deg.C	TRIAL M.F.	Mft
1	0.000000	0.000000	0.000000	0.000000	0.00	0.00		0.0
2	0.000000	0.000000	0.000000	0.000000	0.00	0.00		0.0
3	0.000000	0.000000	0.000000	0.000000	0.00	0.00		0.0
4	0.000000	0.000000	0.000000	0.000000	0.00	0.00		0.0
5	0.000000	0.000000	0.000000	0.000000	0.00	0.00		0.0
6	0.000000	0.000000	0.000000	0.000000	0.00	0.00		0.0
7	0.000000	0.000000	0.000000	0.000000	0.00	0.00		0.0
8	0.000000	0.000000	0.000000	0.000000	0.00	0.00		0.0
9	0.000000	0.000000	0.000000	0.000000	0.00	0.00		0.0
10	0.000000	0.000000	0.000000	0.000000	0.00	0.00		0.0
11	0.000000	0.000000	0.000000	0.000000	0.00	0.00		0.0
12	0.000000	0.000000	0.000000	0.000000	0.00	0.00		0.0
AVE	0.000000	0.000000	0.000000	0.000000	0.00	0.00		0.0

```

REPEATABILITY FOR LAST 10 TRIALS = 0.000 %

```

- A. TEMP. CORRECTION FACTOR FOR LIQUID IN PROVER (CTLp) 0.000
- B. PRESS. CORRECTION FACTOR FOR LIQUID IN PROVER (CPLp) 0.000
- C. COMBINED CORRECTION FACTOR FOR PROVER (CCFp) 0.000
- D. GROSS STANDARD VOLUME FOR PROVER (GSVp) 0.000 Sm3
- E. INDICATED METER VOLUME (IVm) 0.000 m3
- F. TEMP. CORRECTION FACTOR FOR LIQUID IN METER (CTLm) 0.000
- G. PRESS. CORRECTION FACTOR FOR LIQUID IN METER (CPLm) 0.000
- H. COMBINED CORRECTION FACTOR FOR METER (CCFm) 0.000
- I. GROSS STANDARD VOLUME FOR METER (GSVm) 0.000 Sm3
- J. AVG. METER FLOW RATE 0.000 m3/h
- K. METER FACTOR @ PROVING FLOW RATE 0.000
- L. METER FACTOR @ NORMAL METER FLOW RATE OF 0.000 m3/h 0.000
- METER FACTOR TEST RESULTS (%): 1) 0.00 2) 0.00
- M. PROVER MASS 0.000 tonne
- N. METER MASS 0.000 tonne

```

HISTORICAL DATA OF METER FACTORS @ NORMAL METER FLOW RATE OF 0.000 m3/h
INITIAL BASE METER FACTOR (DATE: MM/DD/YY) = 0.000

```

DATE:	MM/DD/YY	MM/DD/YY	MM/DD/YY	MM/DD/YY	MM/DD/YY
FACTOR:	0.000	0.000	0.000	0.000	0.000
DEVIATION(±):	0.00%	0.00%	0.00%	0.00%	0.00%

DATE:	MM/DD/YY	MM/DD/YY	MM/DD/YY	MM/DD/YY	MM/DD/YY
FACTOR:	0.000	0.000	0.000	0.000	0.000
DEVIATION(±):	0.00%	0.00%	0.00%	0.00%	0.00%

PROVED FOR: \_\_\_\_\_ BY : \_\_\_\_\_ DATE: \_\_\_\_\_

WITNESSED BY : \_\_\_\_\_ DATE: \_\_\_\_\_

=====

### B.3.9 Proving Calculations

This section provides information on calculations used in the prove procedure.

The calculations are for volume or mass K-factor and the choice is determined by the K-factor units, pulses/volume or pulses/mass.

**Average Method** The "average method" option indicates how the system performs final averaging:

- The Meter Factor option calculates a meter factor for each run and takes the average of these to arrive at the final meter factor.
- The K-factor option calculates a K-factor for each run and takes the average of these to arrive at the final K-factor.
- The Pulses option takes the average of the pulses, temperature, and pressure and performs a final set of calculations using this average data to arrive at the final meter and K-factor.

Options 1 and 2 are equivalent to the "average meter factor" method used for API Ch.12 Section 2 Part 3 Proving reports. Option 3 is equivalent to the "average data" method.

**Standard References** The prover volume correction calculations correspond to those used by the meter under prove, in which the system transfers the calculation steering variables from the stream.

Name	Standard Reference
Averaging Calcs	General mathematic principles
Stability Calcs	General mathematic principles
Correction Factor (CTLm/CTLp)	Corresponds to Meter calculations – applicable to Liquid <b>only</b>
Correction Factor (CPLm/CPLp)	Corresponds to Meter calculations – applicable to Liquid <b>only</b>
K-factor/Flowrate	API Ch 12
K-factor Deviation	API Ch 4
K-factor Deviation Statistical Method	NORSOK I-105 Annex F
Meter Factor	API Ch 12

#### B.3.9.1 Formulae: Averaging Calculations

##### Run Average Data

$$X_{run} = \frac{\sum X_{inst}}{Samples}$$

where:

$X_{run}$  is the average value of the variable for a single run

$X_{inst}$  is the instantaneous sample value of the variable being averaged  
*Samples* is the number of samples taken during the run

The sampled variables ( $X_{inst}$ ) are:

- Prover temperature
- Prover pressure
- Meter temperature
- Meter pressure
- Standard density

### Run Average Frequency (Hz)

$$FREQ_{run} = \frac{PC}{\Delta t}$$

where:

$FREQ_{run}$  is the average meter frequency for a single run  
 $PC$  is the run pulse count  
 $\Delta t$  is the run flight time (secs)

### Final Average Data (Over Consecutive Good Runs)

$$X_{final} = \frac{\sum X_{run}}{N}$$

where:

$X_{final}$  the final average value of a relevant variable for the  $N$  consecutive good runs  
 $X_{run}$  the value of the variable for a single run  
 $N$  the number of consecutive good runs

The final average variables are:

- Prover pulse count
- Meter pulse count
- Flight time
- Prover temperature
- Prover pressure
- Meter temperature
- Meter pressure
- Vapour pressure – applicable to **Liquid only**
- Standard density
- Prover density
- Meter density
- Meter frequency
- Prover flowrate
- Meter flowrate
- Alpha – applicable to **Liquid only**
- Prover beta – applicable to **Liquid only**
- Meter beta – applicable to **Liquid only**
- CTLm – applicable to **Liquid only**
- CPLm – applicable to **Liquid only**



- CTLp – applicable to **Liquid only**
- CPLp – applicable to **Liquid only**
- Flowing Compressibility (Zf) – applicable to **Gas only**
- Pressure correction factor
- Prover standard volume
- Meter standard volume
- Meter indicated volume
- Prover mass
- Meter mass
- K-factor
- Meter factor

### B.3.9.2 Formulae: Stability Calculations

#### Stream/Prover Discrepancy Checks

$$X_{diff} = X_A - X_B$$

where:

$X_A, X_B$  are the variables being compared

The variables compared are:

- Prover - Meter Temperature
- Prover - Meter Pressure

#### Variable Rate of Change

$$X_{rate} = \frac{X_{new} - X_{old}}{Period}$$

where:

$X_{rate}$  the rate of the variable

$X_{new}$  the new sample value

$X_{old}$  the previous sample value

$Period$  the sampling interval

The variables compared are:

- Prover Temperature
- Prover Pressure
- Meter Flowrate

### B.3.9.3 Formulae: Correction Factor (CTLm/CTLp)

#### Correction Factor for the Effect of Temperature on the Liquid

These factors are calculated according to the product, using the same calculations as the meter under prove – applicable to **Liquid only**.

### B.3.9.4 Formulae: Correction Factor (CPLm/CPLp)

#### Correction Factor for the Effect of Pressure on the Liquid

These factors are calculated according to the product, using the same calculations as the meter under prove – applicable to **Liquid only**.

### B.3.9.5 Formulae: Volume Prover Calculations

#### Prover Indicated Volume (m3)

$$IV_{p_{run}} = \frac{PC_{p_{run}}}{KF_p}$$

where:

$PC_{p_{run}}$  is the run pulse count for the master meter (pls)

$KF_p$  is the master meter K-factor (pls/m<sup>3</sup>)

#### Meter Indicated Volume (m3)

$$IV_{m_{run}} = \frac{PC_{m_{run}}}{KF_m}$$

where:

$PC_{m_{run}}$  is the run pulse count for the meter (pls)

$KF_m$  is the meter K-factor (pls/m<sup>3</sup>)

#### Prover Gross Standard Volume (Sm3) – Liquid

$$GSV_{p_{run}} = IV_{p_{run}} \times CTL_{p_{run}} \times CPL_{p_{run}} \times MF_p$$

where:

$IV_{p_{run}}$  is the indicated volume for the master meter

$CTL_{p_{run}}$  is the correction factor for the effect of temperature on the liquid at the prover, using the average prover run temperature

$CPL_{p_{run}}$  is the correction factor for the effect of pressure on the liquid at the prover, using the average prover run pressure

$MF_p$  is the master meter Meter Factor

#### Meter Indicated Standard Volume (Sm3) – Liquid

$$ISV_{m_{run}} = IV_{m_{run}} \times CTL_{m_{run}} \times CPL_{m_{run}}$$

where:

$IV_{m_{run}}$  is the indicated volume for the meter

$CTL_{m_{run}}$  is the correction factor for the effect of temperature on the liquid at the meter, using the average meter run temperature

$CPL_{m_{run}}$  is the correction factor for the effect of pressure on the liquid at the meter, using the average meter run pressure

#### Volume K-factor (pls/m3) – Liquid

$$KF_{m_{run}} = \frac{PC_{m_{run}} \times CTL_{m_{run}} \times CPL_{m_{run}}}{PC_{p_{run}} \times CTL_{p_{run}} \times CPL_{p_{run}}} \times KF_p$$

where:

$PC_{m_{run}}$  is the run pulse count for the meter (pls)

- $PCp_{run}$  is the run pulse count for the master meter (pls)
- $CTLp_{run}$  is the correction factor for the effect of temperature on the liquid at the prover, using the average prover run temperature
- $CPLp_{run}$  is the correction factor for the effect of pressure on the liquid at the prover, using the average prover run pressure
- $CTLm_{run}$  is the correction factor for the effect of temperature on the liquid at the meter, using the average meter run temperature
- $CPLm_{run}$  is the correction factor for the effect of pressure on the liquid at the meter, using the average meter run pressure
- $KFp$  is the master meter K-factor (pls/m<sup>3</sup>)

**PTZ Factor - Gas**

$$PTZ = \frac{PresP_{run} \times TempM_{run} \times ZfM_{run}}{PresM_{run} \times TempP_{run} \times ZfP_{run}}$$

where:

- $PresP_{run}$  is the prover pressure (psia)
- $PresM_{run}$  is the meter pressure (psia)
- $TempP_{run}$  is the prover temperature (Deg F)
- $TempM_{run}$  is the meter temperature (Deg F)
- $ZfP_{run}$  is the prover flowing compressibility
- $ZfM_{run}$  is the meter flowing compressibility

**Meter Factor – Liquid**

$$MF = \frac{GSVp_{run}}{ISVm_{run}}$$

where:

- $GSVp_{run}$  is the prover gross standard volume (m<sup>3</sup>)
- $ISVm_{run}$  is the meter indicated standard volume (m<sup>3</sup>)

**Meter Factor - Gas**

$$MF_{new} = \frac{IVp_{run} \times PTZ}{IVm_{run}}$$

where:

- $IVp_{run}$  is the prover indicated volume (m<sup>3</sup>)
- $PTZ$  is the PTZ factor
- $IVm_{run}$  is the meter indicated volume (m<sup>3</sup>)

**Prover Indicated Volume Flowrate (m3/h)**

$$IVFRp_{run} = \frac{IVp_{run}}{\Delta t} \times 3600$$

where:

$IVp_{run}$  is the indicated volume for the master meter (m<sup>3</sup>)

$\Delta t$  is the meter run flight time (secs)

### Meter Indicated Volume Flowrate (m3/h)

$$IVFRm_{run} = \frac{IVm_{run}}{\Delta t} \times 3600$$

where:

$IVm_{run}$  is the indicated volume for the meter (m<sup>3</sup>)

$\Delta t$  is the meter run flight time (secs)

## B.3.9.6 Formulae: Mass Prover Calculations

### Prover Pressure Correction Factor

$$PCF = 1 + KTPF \times (P_{run} - P_{ref})$$

where:

$P_{run}$  is the master meter pressure (bar)

$P_{ref}$  is the master meter PCF reference pressure (bar)

$KTPF$  is the master meter KTPF

### Prover Mass (kg)

$$Mp_{run} = \frac{PCp_{run} \times PCF}{KFp}$$

where:

$PCp_{run}$  is the run pulse count for the master meter (pls)

$KFp$  is the master meter K-factor (pls/kg)

$PCF$  is the master meter pressure correction factor

### Meter Mass (kg)

$$Mm_{run} = \frac{PCm_{run} \times 1.0}{KFm_{run}}$$

where:

$PCm_{run}$  is the run pulse count for the meter (pls)

$KFm$  is the meter K-factor (pls/kg)

### Meter Factor

$$MF = \frac{Mp_{run}}{Mm_{run}}$$

where:

$Mp_{run}$  is the master meter mass (kg)

$Mm_{run}$  is the meter mass (kg)

**Mass K-factor (pls/kg)**

$$KFm_{run} = \frac{KFp}{MF_{run}}$$

where:

$MF_{run}$  is the run meter factor

$KFp$  is the master meter K-factor (pls/kg)

**Prover Mass Flowrate (kg/h)**

$$MFRp_{run} = \frac{Mp_{run}}{\Delta t} \times 3600$$

where:

$Mp_{run}$  is the mass for the master meter (kg)

$\Delta t$  is the meter run flight time (secs)

**Meter Mass Flowrate (kg/h)**

$$MFRm_{run} = \frac{Mm_{run}}{\Delta t} \times 3600$$

where:

$Mm_{run}$  is the mass for the meter (kg)

$\Delta t$  is the meter run flight time (secs)

**B.3.9.7 Formulae: K-factor Deviation**

When the required number of consecutive good runs has been achieved, the program checks each individual run K-factor (which make up the  $N$  consecutive good runs) to see how far it deviates from the average. If any run's K-factor deviates by more than the allowable limit then additional runs are performed and the test is repeated.

When all K-factors for the required runs fall within the deviation limit, then the prove is considered successful and the system calculated Final Average Data. At the same time the program stores the single maximum deviation value (repeatability) of the good run K-factors as an indication of how well the prove fell within the deviation tolerance.

**API Ch.4 Method 1 (default)**

$$K_{dev} = \frac{(K_{avg} - K_{run})}{K_{avg}} \times 100$$

**MX-MN/AVG**

$$K_{dev} = \frac{(K_{max} - K_{min})}{K_{avg}} \times 100$$

**MX-MN/MX+MN2**

$$K_{dev} = \frac{(K_{max} - K_{min})}{(K_{max} + K_{min}) \div 2} \times 100$$

**MX-MN/MN**

$$K_{dev} = \frac{(K_{max} - K_{min})}{K_{min}} \times 100$$

**MX-MN/MX\*MN**

$$K_{dev} = \frac{(K_{max} - K_{min})}{(K_{max} \times K_{min})} \times 100$$

**MX-AV/AV**

$$K_{dev} = \frac{(K_{max} - K_{avg})}{K_{avg}} \times 100$$

**AV-MN/AV**

$$K_{dev} = \frac{(K_{avg} - K_{min})}{K_{avg}} \times 100$$

where:

- $K_{dev}$  is the K-factor deviation (%)
- $K_{avg}$  is the average K-factor of  $N$  consecutive good runs (pls/m<sup>3</sup>)
- $K_{min}$  is the minimum K-factor of  $N$  consecutive good runs (pls/m<sup>3</sup>)
- $K_{max}$  is the maximum K-factor of  $N$  consecutive good runs (pls/m<sup>3</sup>)
- $K_{run}$  is the run K-factor being checked (pls/m<sup>3</sup>)

**Statistical**

$$K_{dev} = 200 \times t_{N-1} \times \frac{S_{N-1}}{K_{avg} \times \sqrt{N}}$$

where:

- $K_{dev}$  is the K-factor deviation (%)
- $K_{avg}$  is the average K-factor of  $N$  consecutive good runs (pls/m<sup>3</sup>)
- $t_{N-1}$  is the uncertainty band confidence level, which is a selectable value (95%, 99%, 99.5%, or a user-defined value). NORSOK requires this method (using the student-t distribution) at a recommended value of 95%. API MPMS Ch.4.8 also recommends 95%.
- $S_{N-1}$  is the standard deviation of K-factor of  $N$  consecutive good runs (pls/m<sup>3</sup>)

**B.3.9.8 Meter Factor Deviation Test**

This section defines Meter Factor Deviation tests – applicable to **Liquid only**.

### Calculated Meter Factor versus Initial Base Meter Factor

$$\% \text{ Deviation Test 1} = \frac{(\text{MFCP}_{\text{FRN}} - \text{Initial Base Meter Factor})}{(\text{Initial Base Meter Factor})} \times 100$$

where:

$\text{MFCP}_{\text{FRN}}$  is the calculated meter factor from current prove at normal flow rate.

Maximum deviation of  $\pm 0.25\%$ .

### Calculated Meter Factor versus Average of Previous Historical Meter Factors

$$\% \text{ Deviation Test 2} = \frac{(\text{MFCP}_{\text{FRN}} - \text{Average of Previous Meter Factors})}{(\text{Average of Previous Meter Factors})} \times 100$$

where:

$\text{MFCP}_{\text{FRN}}$  is the calculated meter factor from current prove at normal flow rate

Maximum deviation of  $\pm 0.1\%$ .

*[This page is intentionally left blank.]*



## Appendix C – Batching

### In This Chapter

C.1	Batching Overview .....	C-2
C.1.1	Product Table .....	C-2
C.1.2	Station Batch Setup .....	C-8
C.1.3	Product Interface Detection .....	C-15
C.1.4	Slops Handling Examples .....	C-18
C.2	Batch Sequence and Control .....	C-19
C.2.1	Batch Sequence Stages .....	C-20
C.2.2	Retrospective Batch Totals .....	C-29
C.2.3	Batch Alarms .....	C-30
C.2.4	Batch Ticket .....	C-30
C.3	Batch Recalculation .....	C-32
C.3.1	Displays .....	C-32
C.3.2	Batch Ticket .....	C-36
C.3.3	Recalculating Batches .....	C-38
C.4	Flow Switching .....	C-47
C.4.1	Station Flow Switching Setup .....	C-47
C.4.2	Stream Flow Switching Setup .....	C-49
C.4.3	Flow Switching Algorithms .....	C-50
C.4.4	Alarms .....	C-53
C.5	Batch Stack .....	C-53
C.5.1	Configuring the Batch Stack Through the PCSetup Editor .....	C-54
C.5.2	Configuring the Batch Stack with the System Editor .....	C-56
C.5.3	Configuring the Batch Stack through the Front Panel Display .....	C-58
C.5.4	Slot Edit Commands (Front Panel Display) .....	C-59
C.5.5	Configuring the Batch Stack from the Webserver .....	C-64
C.5.6	Slot Edit Commands (Webserver) .....	C-65
C.6	Basic Batching Setup .....	C-69

This appendix primarily covers batching on a liquid system and provides an overview of the three batching methods the S600+ supports: standalone station, supervised station, and standalone stream.

#### Notes:

- You **must** select Batching and a Product Table option in your initial S600+ configuration in order to perform a batching operation.
- You **must** configure at least one Product Table prior to starting a batch. For more information, refer to Product Table.
- If you have two stations, you **must** configure **both** stations for batching in your initial S600+ configuration.
- Batching assumes that the densitometer is at the station header (Station Option 3 in the wizard). Density inputs at the stream level (Stream options 3, 4 and 5 in the wizard) are **not** supported.
- An S600+ running firmware version 6.22 or greater cannot use a batching configuration created with a Config600 version prior to 3.2.7.0. In this situation, you **must** create a new configuration.
- The Batch Stack, Product Table, and Product Interface Detection features are not implemented in gas batching.

## C.1 Batching Overview

---

Batching provides the control process for loading a defined quantity of product. The process is run as a sequence stepping through a series of stages.

During a batch, each stream is assigned a volume or mass total to flow; the data passes to the stream that then controls its own batch through the various batch stages, which may include opening and closing stream valves and regulating the flow using a flow control valve.

An operator or supervisory computer can set the batch quantity and specify a startup flowrate, a nominal flowrate for the main body of the batch, and a top off flowrate at the end of batch to provide an accurate quantity. The quantity can be measured by volume or mass.

The batch can be controlled from the station that distributes the flow across available streams configured within the same S600+. It does not work with streams in separate S600+ flow computers, such as requiring a comms link. Each stream then runs its own batch. The sequence can be stepped along automatically by the station or it can be supervised by a remote host computer.

Alternatively, each stream can control its own batch sequence in a standalone mode

The station sequence employs flow switching to open and close streams according to their availability and the required flowrate.

The batch sequence also provides a mechanism for retrospective adjustment of totals if the K-factor or meter factor changes during the batch. The process occurs at the stream and can be done either at most stages during the batch once flow starts or at the end of batch (if you enable user stages). The adjustment automatically reflects in the station totals. However, the adjustment can be made only once though the S600+ uses the new K-factor/meter factor in subsequent totalisation.

---

**Note:** This adjustment method is not valid for applications using K-factor/meter factor linearisation because it is difficult to derive an accurate historic K-factor/meter factor.

---

### C.1.1 Product Table

The product table allows you to define up to 16 sets of constants for the Observed Density Correction / Standard Density Correction calculations at run time. This is useful for batching applications where the product being metered changes. The product details are sent to the stream when a batch starts or if the operator manually changes the product number at the station.

**Notes:**

- If the product table with meter factor curve option was selected, then remember to setup the associated product Meter factor / K-factor curve on the Linearisation form. Please refer to the Stream Configuration document.
- The active product can be changed at run time via the station menu **PRODUCT TABLE**.

1. Select **Product Table** from the hierarchy menu. The Product Table screen displays in the right-hand pane.

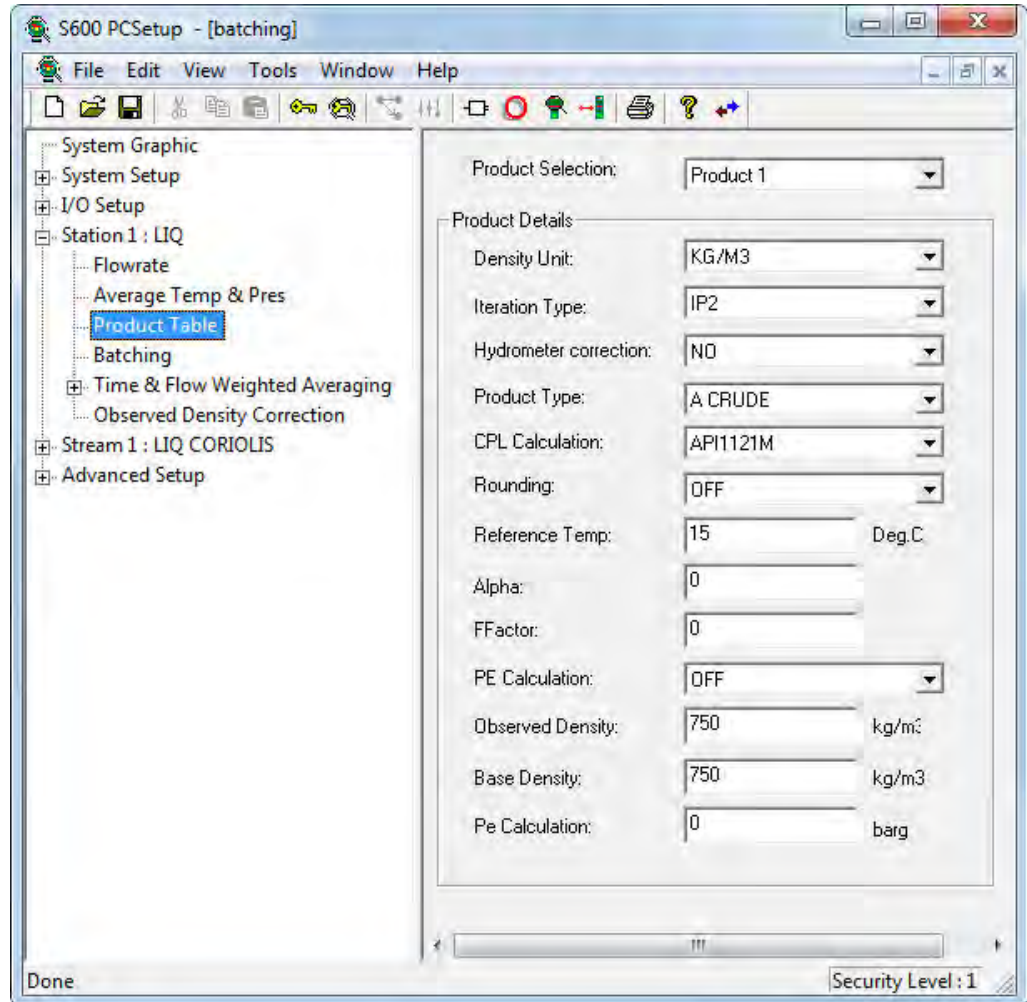

Figure C-1. Product Table Options

2. Indicate a product in the **Product Selection** field. Click ▼ to display all valid products (product range is 1 through 16).
3. Enter the **Product Details** for the selected product.

Field	Description
Density Unit	Indicates the density units the S600+ uses for the density correction calculations. Click ▼ to display all valid values.
DEG.API	Use degrees API.
S.G.	Use specific gravity.

Field	Description
	<b>KG/M3</b> Use kilograms per cubic meter. The default is <b>KG/M3</b> .
	<b>CH. 11 2004/7 CUST</b> Use API MPMS Chapter 11.1 2004, Addendum 1, 2007 Imperial Units.
	<b>CH. 11 2004/7 METRIC</b> Use API MPMS Chapter 11.1 2004, Addendum 1, 2007 Metric Units.
	<b>NORSOK I-105</b> Use I-105 Appendix D density correction.
<b>Iteration Type</b>	Indicates the iteration type for the density correction calculations. Click ▼ to display all valid values.
	<b>ASTM</b> Use the iterative temperature and pressure correction as defined by ASTM/API, Chapter 12.
	<b>IP2</b> Use the iterative temperature and pressure correction as defined in IP Paper 2 (ISO 92-1). The default is <b>IP2</b> .
<b>Hydrometer Correction</b>	Indicates whether the S600+ applies the hydrometer correction values to the calculation.
	<b>NO</b> Do not apply hydrometer correction values. The default is <b>NO</b> .
	<b>YES</b> Do apply hydrometer correction values.
<b>Product Type</b>	Indicates the type of petroleum product involved in the calculation. Click ▼ to display all valid values. The default is <b>A CRUDE</b> .
	<b>A CRUDE</b> If Density Table Units = KG/M3 and reference temperature = 15 Deg C, Petroleum Measurement Tables 1980 Tables 53A and 54A. If Density Table Units = KG/M3 and reference temperature = 20 Deg C, Petroleum Measurement Tables 1988 Tables 59A and 60A. If Density Table Units = SG, Petroleum Measurement Tables 1980 Tables 23A and 24A. If Density Table Units = DEG API, Petroleum Measurement Tables 1980 Tables 5A and 6A. If Density Table Units = CH.11 2004/7, Cust API MPMS Chapter 11 2004. If Density Table Units = CH.11 2004/7, Metric API MPMS Chapter 11 2004.

Field	Description
<b>B REFINED</b>	<p>If Density Table Units = KG/M3 and reference temperature = 15 Deg C, Petroleum Measurement Tables 1980 Tables 53B and 54B.</p> <p>If Density Table Units = KG/M3 and reference temperature = 20 Deg C, Petroleum Measurement Tables 1988 Tables 59B and 60B.</p> <p>If Density Table Units = SG, Petroleum Measurement Tables 1980 Tables 23B and 24B.</p> <p>If Density Table Units = DEG API, Petroleum Measurement Tables 1980 Tables 5B and 6B.</p> <p>If Density Table Units = CH.11 2004/7, Cust API MPMS Chapter 11 2004.</p> <p>If Density Table Units = CH.11 2004/7, Metric API MPMS Chapter 11 2004.</p>
<b>C SPECIAL</b>	<p>If Density Table Units = KG/M3, Petroleum Measurement Tables 1980 Table 54C.</p> <p>If Density Table Units = SG, Petroleum Measurement Tables 1980 Tables 23C and 24C.</p> <p>If Density Table Units = DEG API, Petroleum Measurement Tables 1980 Tables 5C and 6C.</p> <p>If Density Table Units = CH.11 2004/7, Cust API MPMS Chapter 11 2004.</p> <p>If Density Table Units = CH.11 2004/7, Metric API MPMS Chapter 11 2004.</p> <p><b>Note:</b> Table 53C is not implemented as the assumption is made that the base density is already known. This is because Table 53C allows for a keypad entry of Alpha, and if this is known then the base density would be known.</p>
<b>D LUBE OILS</b>	<p>If Density Table Units = KG/M3 and reference temperature = 15 Deg C, Petroleum Measurement Tables 1982 Tables 53D and 54D.</p> <p>If Density Table Units = KG/M3 and reference temperature = 20 Deg C, Petroleum Measurement Tables 1988 Tables 59D and 60D.</p> <p>If Density Table Units = SG, Petroleum Measurement Tables 1982 Tables 23D and 24D.</p> <p>If Density Table Units = DEG API, Petroleum Measurement Tables 1982 Tables 5D and 6D.</p> <p>If Density Table Units = CH.11 2004/7, Cust API MPMS Chapter 11 2004.</p> <p>If Density Table Units = CH.11 2004/7, Metric API MPMS Chapter 11 2004.</p>

Field	Description
<b>LIGHT 1986</b>	ASTM-IP-API Petroleum Measurement Tables for Light Hydrocarbon Liquids 1986 Tables 53 and 54.
<b>ASTM IP 1952</b>	ASTM-IP Petroleum Measurement Tables 1952 Tables 23, 24, 53 and 54.
<b>TABLE LOOKUP</b>	S600+ reads values from a file in the Config600 3.0/Config/Project Name/extras directory and transfers that data into the S600+ with the configuration file. The default files hold values for for the ASTM-IP Petroleum Measurement Tables 1952 Tables 5 and 6.
<b>USER K0K1</b>	If Density Table Units = KG/M3, Petroleum Measurement Tables 1980 Tables 53A and 54A with user entered values K0 and K1. If Density Table Units = SG, Petroleum Measurement Tables 1980 Tables 23A and 24A with user entered values K0 and K1. If Density Table Units = DEG API, Petroleum Measurement Tables 1980 Tables 5A and 6A with user entered values K0 and K1.
<b>LIGHT TP25</b>	GPA TP-25 1998 (API Tables 23E and 24E).
<b>AROMATICS D1555-95</b>	ASTM D1555-95 Table lookup.
<b>LIGHT TP27</b>	GPA TP-27 2007 (API Tables 23E, 24E, 53E, 54E, 59E and 60E).
<b>AROMATICS D1555M-00</b>	ASTM D1555M-00 Table lookup.
<b>AROMATICS D1555M-04A</b>	ASTM D1555M-04a Calculation.
<b>AROMATICS D1555M-08</b>	ASTM D1555M-08 Calculation.
<b>STO5.9 08 B1 UGC</b>	Gazprom STO-5.9 2008 Addendum B.1 Unstable Gas Condensate.
<b>STO5.9 08 B2 SLH</b>	Gazprom STO-5.9 2008 Addendum B.2 Stable Liquid Hydrocarbon.
<b>STO5.9 08 B3 WFLH</b>	Gazprom STO-5.9 2008 Addendum B.3 Wide Fraction Liquid Hydrocarbon.
<b>CPL Calculation</b>	Indicates the specific CPL calculation the S600+ uses to calculate the liquid pressure correction factor for the selected product. Click ▼ to display all valid values. <b>Note:</b> This field does not display if you select Density Table Units CH.11 2004 CUST or CH.11 2004 METRIC or a Gazprom Product Type because these standards also specify the CPL calculation.
<b>OFF</b>	No CPL calculation.
<b>API1121</b>	API MPMS Ch.11.2.1 1984.
<b>API1122</b>	API MPMS Ch.11.2.1 1986.
<b>API1121M</b>	API MPMS Ch.11.2.1M 1984. The default is API1121M.

<b>Field</b>	<b>Description</b>
	<b>API1122M</b> API MPMS Ch.11.2.1M 1986.
	<b>CONSTANT</b> Use a value you enter.
	<b>DOWNER</b> Paper entitled Generation of New Compressibility Tables for International Use presented by L. Downer 1979.
<b>Rounding</b>	Indicates whether the S600+ rounds the calculation results for the selected product. Click ▼ to display all valid values.
	<b>OFF</b> No rounding occurs. The default is <b>OFF</b> .
	<b>NATIVE</b> Rounding to the rules specified in the selected calculation standard.
	<b>API Ch.12.2 Part 2</b> Rounding to API MPMS Ch.12.2 Part 2 – Measurement Tickets 1995.
	<b>API Ch.12.2 Part 3</b> Rounding to API MPMS Ch.12.2 Part 3 – Proving Reports 1998.
	<b>Flocheck</b> Rounding to Emerson Flocheck verification software package.
	<b>ASTM D1250-04 Ch. 11</b> API MPMS Ch.11.1 2004 (ASTM D1250-04) method to round to the Petroleum Measurement Tables 1980 Tables.
	<b>DECC 1980</b> DTI/DECC requirements for Petroleum Measurement Tables 1980 Tables. No rounding occurs and an iteration tolerance of 0.0001.
<b>Reference Temp</b>	Sets the reference temperature for the correction calculations. The default is 15 degrees C.
<b>Alpha</b>	Sets the coefficient of thermal expansion. The default is <b>0</b> .
<b>FFactor</b>	Sets the compressibility factor for the liquid (also known as the beta factor). The default is <b>0</b> .
<b>PE Calculation</b>	PE Calculation provides a method to calculate the fluid Equilibrium Vapour Pressure for the selected product. The PE Calculation is normally assumed to be zero, but you may use it for Natural Gas Liquids (NGL) and similar applications.
	<b>OFF</b> S600+ does not use a PE Calculation. The default is <b>OFF</b> .
	<b>GPA TP-15 1988 EQN 2</b> Calculate using the GPA TP-15 1988 Equation 2.
	<b>GPA TP-15 2003 EQN 2</b> Calculate using the GPA TP-15 2003 Equation 2.
	<b>GPA TP-15 1988 EQN 3</b> Calculate using the GPA TP-15 1988 Equation 3.
	<b>GPA TP-15 2003 EQN 4</b> Calculate using the GPA TP-15 2003 Equation 4.
<b>Observed Density</b>	Sets the observed density for the selected product.
<b>Base Density</b>	Sets the base density for the selected product.
<b>Pe Calculation</b>	Sets the observed equilibrium vapour pressure (Pe) for the selected product.

## C.1.2 Station Batch Setup

To configure the Batching application:

1. Select **Batching** from the hierarchy menu. The system displays the associated settings in the right-hand pane.

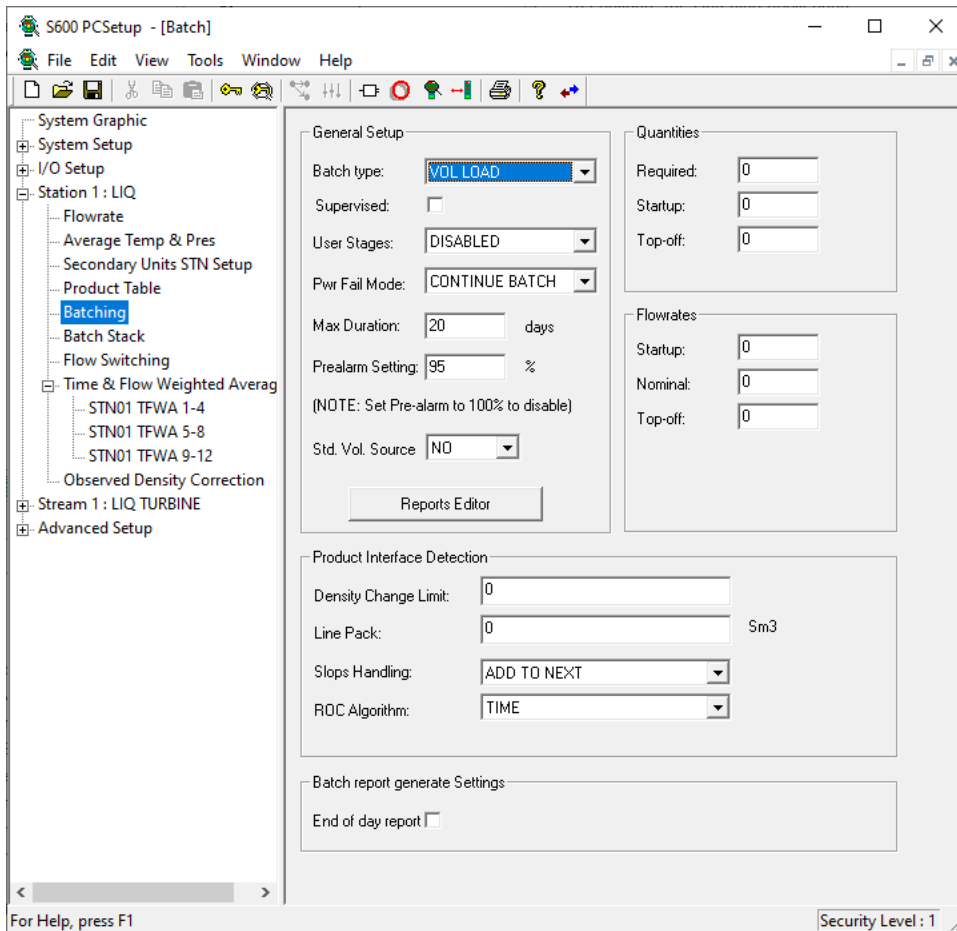

Figure C-2. Station Batching

2. Complete the following fields.

Field	Description
<b>Batch Type</b>	Identifies the type of batch. Click ▼ to display all valid values. <b>Note:</b> If you require a simple daily batch volume report, you can request this through the Reports screen. Click <b>Reports Editor</b> to access the Reports option on the hierarchy menu.



Field	Description
<b>VOL LOAD</b>	<p>Bases the batch on GUVOL flow. This is the <b>default</b>.</p> <ul style="list-style-type: none"> <li>▪ All stages are followed (Define, start, nominal, top-off, terminate etc).</li> <li>▪ Batch automatically goes to COMPLETE once the required volume has been loaded.</li> <li>▪ Current batch information is copied to previous and FWA reset on start of new batch.</li> </ul>
<b>MASS LOAD</b>	<p>Bases the batch on mass flow.</p> <ul style="list-style-type: none"> <li>▪ All stages are followed (Define, start, nominal, top-off, terminate etc).</li> <li>▪ Batch automatically goes to COMPLETE once the required mass has been loaded.</li> <li>▪ Current batch information is copied to previous and FWA reset on start of new batch.</li> </ul>
<b>DIGIN</b>	<p>Triggers batches by the station digital input BCH START.</p> <ul style="list-style-type: none"> <li>▪ Uses DEFINE command (operator) and goes straight to MONITOR MODE.</li> <li>▪ Will then accept TERMINATE command (operator) <b>only</b>.</li> <li>▪ Uses a digital input to do a RESTART – which will copy current batch data to previous and reset (including FWA).</li> </ul>
<b>INTERFACE</b>	<p>Bases the batch on the differences in density (see <a href="#">Section C.1.3 Product Interface Detection</a>).</p> <ul style="list-style-type: none"> <li>▪ Uses DEFINE command (operator) and goes straight to MONITOR MODE.</li> <li>▪ Will then accept TERMINATE command (operator) <b>only</b>.</li> <li>▪ Uses a density change to do a RESTART – which will copy current batch data to previous and reset (including FWA).</li> </ul>

Field	Description
<b>BASE TIME 1</b>	<p>Bases the batch on the "Base Time 1" hour. Each batch lasts one day.</p> <ul style="list-style-type: none"> <li>▪ Uses DEFINE command (operator) and goes straight to MONITOR MODE.</li> <li>▪ Will then accept TERMINATE command (operator) <b>only</b>.</li> <li>▪ Uses a day change to do a RESTART – which will copy current batch data to previous and reset (including FWA).</li> </ul>
<b>BASE TIME 2</b>	<p>Bases the batch on the "Base Time 2" hour. Each batch lasts one day.</p> <ul style="list-style-type: none"> <li>▪ Uses DEFINE command (operator) and goes straight to MONITOR MODE.</li> <li>▪ Will then accept TERMINATE command (operator) <b>only</b>.</li> <li>▪ Uses a day change to do a RESTART – which will copy current batch data to previous and reset (including FWA).</li> </ul>
<b>BASE TIME 3</b>	<p>Bases the batch on the "Base Time 3" hour. Each batch lasts one day.</p> <ul style="list-style-type: none"> <li>▪ Uses DEFINE command (operator) and goes straight to MONITOR MODE.</li> <li>▪ Will then accept TERMINATE command (operator) <b>only</b>.</li> <li>▪ Uses a day change to do a RESTART – which will copy current batch data to previous and reset (including FWA).</li> </ul>

Field	Description
CONT VOL LOAD	<p>Bases the batch on GUVOL flow and a new batch is automatically triggered when the current batch ends. A new batch can be triggered manually, before the required quantity is achieved, by using the RESTART command.</p> <ul style="list-style-type: none"> <li>▪ Uses DEFINE command (operator) and goes straight to MONITOR MODE.</li> <li>▪ Will then accept RESTART command (operator) or TERMINATE command (operator) <b>only</b>.</li> <li>▪ Uses a USER START/STOP object to do a RESTART – which will copy current batch data to previous and reset (including FWA).</li> </ul> <p><b>Notes:</b></p> <ul style="list-style-type: none"> <li>▪ Select this option <b>only</b> if the flow is continuous.</li> <li>▪ The current flow weighted average values are copied to the previous flow weighted average values if a RESTART is performed when there is flow.</li> </ul>

Field	Description
<p><b>CONT MASS LOAD</b></p>	<p>Bases the batch on mass flow and a new batch is automatically triggered when the current batch ends. A new batch can be triggered manually, before the required quantity is achieved, by using the RESTART command.</p> <ul style="list-style-type: none"> <li>▪ Uses DEFINE command (operator) and goes straight to MONITOR MODE.</li> <li>▪ Will then accept RESTART command (operator) or TERMINATE command (operator) <b>only</b>.</li> <li>▪ Uses a USER START/STOP object to do a RESTART – which will copy current batch data to previous and reset (including FWA).</li> </ul> <p><b>Notes:</b></p> <ul style="list-style-type: none"> <li>▪ Select this option <b>only</b> if the flow is continuous.</li> <li>▪ The current flow weighted average values are copied to the previous flow weighted average values if a RESTART is performed when there is flow.</li> </ul>
<p><b>Supervised</b></p>	<p>Indicates the point from which the batch is controlled. Leave this option blank to permit the batch to automatically step through each phase. Select this option if you intend either to manually monitor the process or have a supervisory computer monitor the batch process.</p> <p><b>Note:</b> If Supervised is selected at the station, only a subset of batch commands are accepted and only VOL LOAD and MASS LOAD Batch Types are supported.</p>
<p><b>User Stages</b></p>	<p>User stages provide a halt in the sequence waiting for the sequence stage number to be changed. This is normally handled by a LogiCalc which you can edit to provide user specific logic as the prove progresses. If the stage number does not change, the sequence will not progress past these stages. Click ▼ to display all valid values.</p>
<p><b>DISABLED</b></p>	<p>S600+ does not execute user stages. The default is <b>Disabled</b>.</p>
<p><b>ENABLED</b></p>	<p>S600+ executes user stages and requires a LogiCalc.</p>

Field	Description
	<p><b>ARAMCO</b> Enables specific application features. If you require this feature, contact Technical Support.</p>
<b>Pwr Fail Mode</b>	Sets how the system handles the currently running batch after a power cycle.
	<p><b>CONTINUE BATCH</b> Continues the batch after power is resumed.</p>
	<p><b>START NEW BATCH</b> Stops the batch that started before the power failure and starts a new batch when the power resumes.</p>
	<p><b>STOP BATCH</b> Stops the batch that started before the power failure after the power resumes.</p>
<b>Max Duration</b>	Sets the maximum number of days a batch will run. The batch restarts after the max duration has been reached.
<b>Prealarm Setting</b>	Triggers an operator warning based on the batch's percentage of completion. Indicate a percentage value (such as 95) to raise a warning alarm or set a value of 100 to disable this alarm.
<b>Std. Vol. Source</b>	Indicates if the corrected volume is used for the batch quantity. Click ▼ to display all valid values.
	<p><b>NO</b> Use the uncorrected volume as the batch quantity. This is the <b>default</b>.</p>
	<p><b>YES</b> Use the corrected volume as the batch quantity.</p>
<b>Reports Editor</b>	Click <b>Reports Editor</b> to display a screen identifying the reports currently associated with your configuration.
<b>Density Change Limit</b>	Sets the minimum change in density, per m3 or second, for which an interface should be flagged. All density variations which are below this limit are ignored by the algorithm. If the ROC Algorithm option is set to VOLUME, the parameter is specified in units of density divided by units of volume. If the ROC Algorithm option is set to TIME, the parameter is specified in units of density divided by units of time.
<b>Line Pack</b>	Sets the amount of product that is required to pass between the moment a valid interface has been detected at the station densitometer and the moment the interface is actually flagged (reported) – when the interface has reached the stream meter. The line pack is expressed as a volume. If you set the parameter to 0, the interface is flagged as soon as the algorithm detects it at the station densitometer. Refer to figure <i>Figure C-6</i> .

Field	Description	
<b>Slops Handling</b>	Sets how the system handles transmix ("slops"). Valid options are:	
	<b>ADD TO NEXT</b>	The slops (transmix) is considered part of the batch that just started. The interface is considered to be right at the boundary between the end of the previous product and the start of the slops.
	<b>ADD TO CURRENT</b>	The slops (transmix) is considered part of the batch that just ended. The interface is considered to be right at the boundary between the end of the slops and the start of the next product.
	<b>SEPARATE</b>	The slops (transmix) is considered to be a separate batch. Its properties are considered to be the same as the batch that just ended.
<b>ROC Algorithm</b>	Sets how the system computes the density rate of change. Valid values are:	
	<b>TIME</b>	Rate of change is computed as the change in density with respect to time.
	<b>VOLUME</b>	Rate of change is computed as the change in density with respect to volume.

3. Complete the **Required**, **Startup**, and **Top-off** values for both **Quantities** and **Flowrates**, so that:

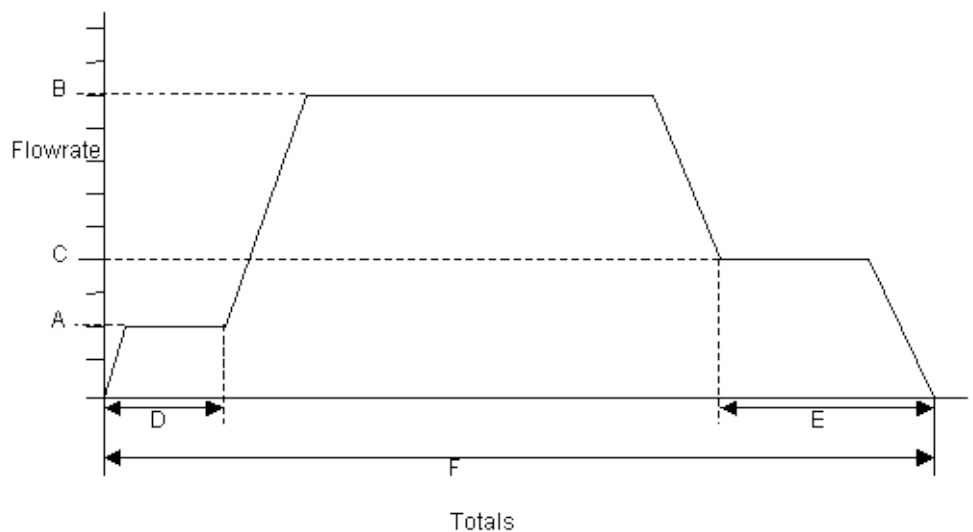

Figure C-3. Flowrate Totals

Where:

- A** Startup flowrate.
- B** Nominal flowrate.
- C** Top-off flowrate.
- D** Startup volume.
- E** Nominal volume.
- F** Top-off volume.

4. Click on the hierarchy menu when finished. A confirmation dialog box displays.
5. Click **Yes** to apply your changes. The PCSetup screen displays.

### C.1.3 Product Interface Detection

The Product Interface Detection logic detects and flags the boundary between two adjacent products, determining the end of one product and the beginning of another.

To enable Product Interface Detection, you must first enable the Batching option at the station level when generating a new configuration file. You enable the option only at the station level, although you can configure the option for each station independently. The option runs in the background once started, monitors density changes in a fixed volume of product, and flags any interfaces.

You define four parameters to configure the Product Interface Detection algorithm, which you access either through PCSetup, the S600+'s front panel, or Webserver.

- To access the parameters from PCSetup, select **Station** (number) > **Batching**.
- To access the parameters from the front panel or the Webserver, select **Operator** > **Station** (number) > **Batch I/F**.

**Configuration** The options below are available via PCSetup, front panel and webserver. For more information, refer to [C.1.2 Station Batch Setup](#).

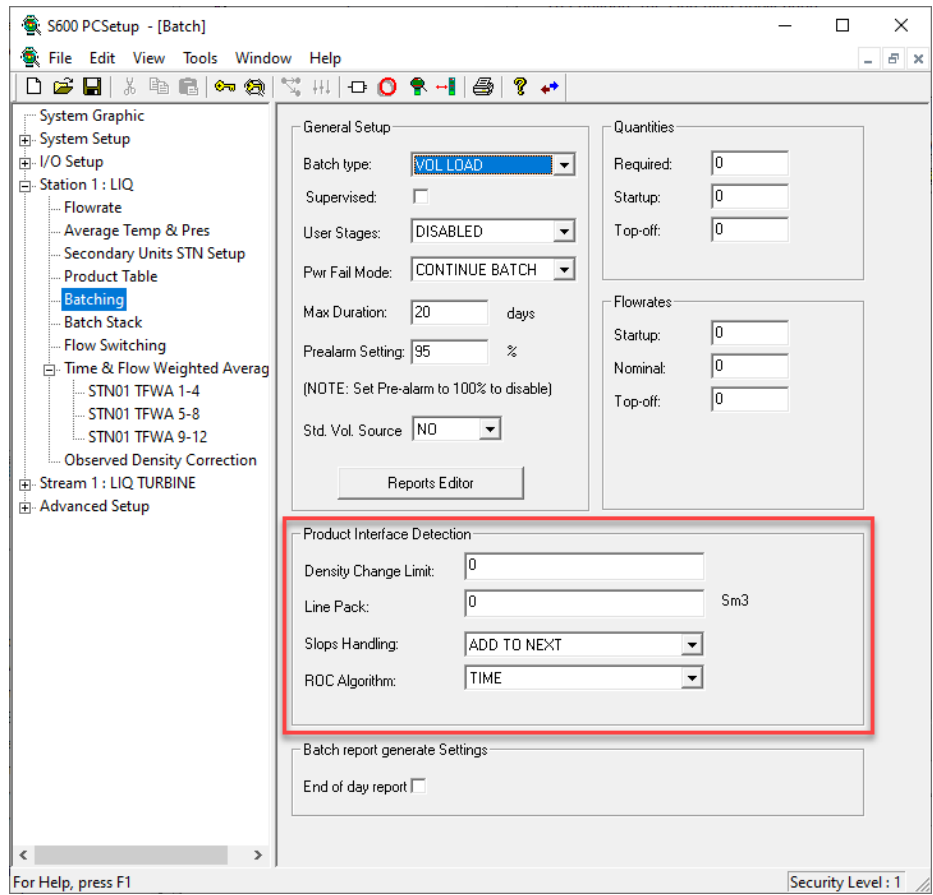

Figure C-4. Product Interface Detection Form (in PCSetup)

**Functionality** By comparing product densities in the same unit of volume, the algorithm notes changes in base density over a fixed amount of product. When the algorithm detects a change above a certain configurable limit it marks an interface. The algorithm performs an average rate of change check to filter out small changes in density or sudden density spikes

The rate of change of density varies depending on the process conditions and the relative density of the two products. Generally, two products with similar densities mix much more than two products with largely different densities. The rate of change in density in the first case is lower than the rate of change in the second case.

Figure C-5. uses three products (A, B, and C) in an idealized example of how the algorithm works. The density of Product A (100 [units of density]) is much closer to the density of Product C (700 [units of density]) than to the density of Product B (900 [units of density]). Accordingly, the transition from Product A to Product B is much faster (in terms of units of volume) than the transition from Product A to Product C. The rates of change can be seen in the following graphic:

- From Product A to Product B: ROC = 200 [units of density / units of volume]
- From Product A to Product C: ROC = 100 [units of density / units of volume]



The algorithm computes the average rate of change (ROC) over a fixed number of volume or time units. If the computed ROC is greater than the operator-entered ROC, the algorithm considers this variation as a change in product and flags it. Otherwise, the algorithm ignores the change.

The following graphic shows three different operator-set ROC limits (indicated by the dashed lines): **300** [units of density / units of volume], **150** [units of density / units of volume], and **75** [units of density / units of volume].

The three operator-set limits depict three different situations. If the ROC limit is set too high for the product density changes for that particular pipeline, then the algorithm ignores all transitions. If the ROC limit is set too low, then the algorithm picks up most transitions but it might also pick up unwanted transitions. For the algorithm to work properly, you must set the ROC lower than the lowest product transitions for that mix.

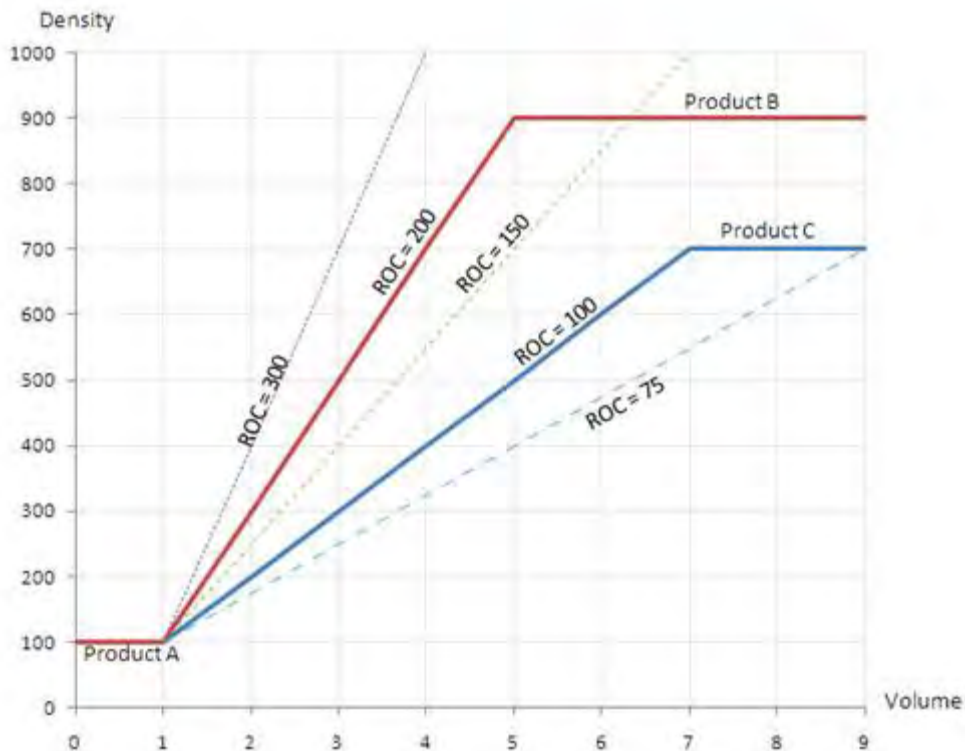

Figure C-5. Idealised Example of Transitions between Products with Different Densities

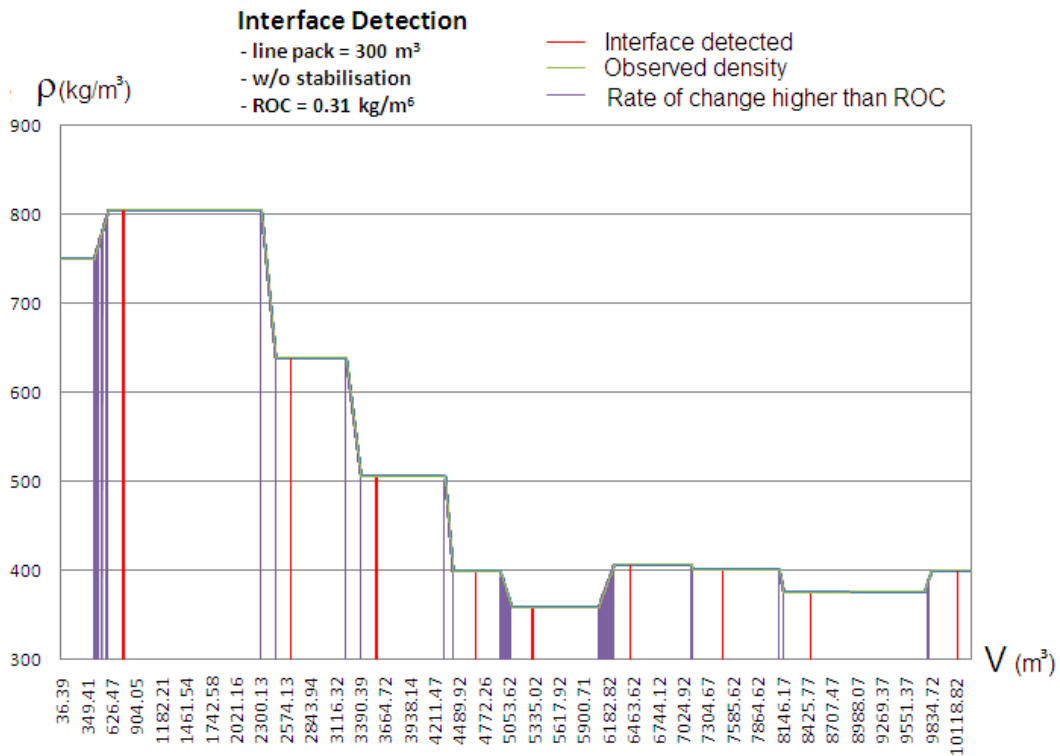

Figure C-6. Product Interface Detection Algorithm (Line Pack at 300 m<sup>3</sup>)

### C.1.4 Slops Handling Examples

The three following examples show how the system handles slops, based on the option (respectively, **Add to Current**, **Add to Next**, or **Separate**) you select in the Slops Handling field.

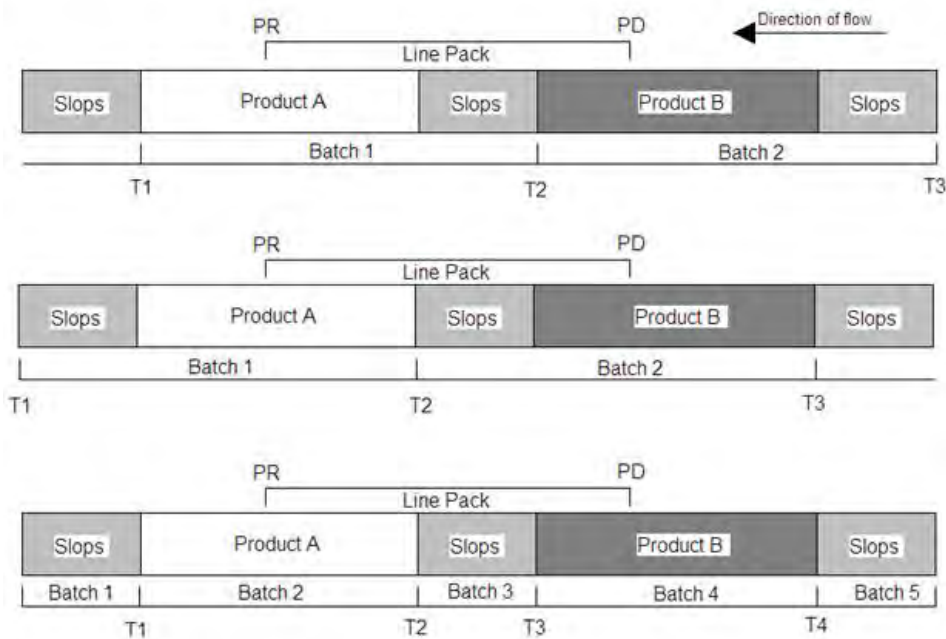

Figure C-7. Slops Handling Examples

Legend	
PD	Point of Detection; the point at which the densitometer first detects the interface
PR	Point of Report; the point at which the meter reports the interface
Line Pack	The difference in volume between PD and PR
T1, T2, T3, etc.	Points (or triggers) in the flowing product at which an interface is triggered

## C.2 Batch Sequence and Control

The sequence can be stepped along automatically by the station or it can be supervised by a remote host computer. Each stream can control its own batch sequence in a standalone mode.

Before you initiate a batch, ensure that the Delivery/Receipt and Official/Unofficial modes are correctly configured on the S600+'s front panel displays (BCH CURR INPUTS).

The S600+ flow computer's front panel display provides the following commands you can use to control the batch sequence (**Operator > Station > Batch > Batch Command**):

Display	Description
<b>Define</b>	Accept the load parameters and reset batch totals.
<b>Start</b>	Open valves and commence startup flow. Available only for the VOL LOAD and MASS LOAD batch types.
<b>Nominal</b>	Ramp up to the nominal flowrate. Available only for the VOL LOAD and MASS LOAD batch types. <b>Note:</b> Command will be rejected if Supervised is selected at the station.
<b>Topoff</b>	Ramp down to the top-off flowrate. Available only for the VOL LOAD and MASS LOAD batch types. <b>Note:</b> Command will be rejected if Supervised is selected at the station.
<b>Hold</b>	Pause the batch. Available only for the VOL LOAD and MASS LOAD batch types. <b>Note:</b> Command will be rejected if Supervised is selected at the station.
<b>Terminate</b>	End the batch.
<b>Restart</b>	Stops the current batch and starts a new one. Available only for the CONT, VOL LOAD and CONT, MASS LOAD batch types. <b>Notes:</b> <ul style="list-style-type: none"> <li>▪ Select this option <b>only</b> if the flow is continuous.</li> <li>▪ The current flow weighted average values are copied to the previous flow weighted average values if a RESTART is performed when there is flow.</li> <li>▪ Command will be rejected is Supervised is selected at the station.</li> </ul>

## C.2.1 Batch Sequence Stages

The batch sequence functions in stages. *Table C-1* shows the complete list of station stages for a typical application batching scenario.

*Table C-1. Station Batch Sequence Stages*

Stage	Display	Description
0	IDLE	Halted: idle, await Define command
1	WAIT SAMPLER	Wait for the sampler to reset
2	BATCH DEFINED	Halted: await Start command
3	WAIT STREAMS START	Wait for streams to start
4	BEGIN STARTUP	Set the startup flowrate, wait for station flowrate > startup flowrate
5	IN STARTUP	Wait for station total > startup volume
6	BEGIN NOMINAL	Set the nominal flowrate, wait for station flowrate > nominal flowrate
7	IN NOMINAL	Wait for station total > (specified – top-off) total
8	BEGIN TOPOFF	Set the top-off flowrate, wait for station flowrate > top-off flowrate
9	IN TOPOFF	Wait for station total > specified total
10	BEGIN HOLD	Suspend flow, wait for station flowrate = 0
11	IN HOLD	Halted: await Start or Terminate command
12	STREAM BATCH	Not implemented
13	WAIT STREAMS CLOSE	Wait for station flowrate = zero
14	WAIT STREAMS END	Wait for streams to return Idle
15	BATCH COMPLETE	Print report, return to Idle
16	BATCH MONITOR	Halted: await a stage change.
17	WAIT RECALC CMND	Halted: await Recalc or Terminate command
18	RECALCULATING	Wait for streams to return Recalc Complete
19	TERMINATING	Wait for streams to return to Idle
20	RECALCULATE COMPLETE	Halted: await Terminate command or an external stage change

## C.2.1.1 Station Sequence Stage Descriptions

Table C-2 shows all the stages of a default batch sequence.

Table C-2. Batch Sequence Stages (Complete)

Sequence Stage	Description
0	<p><b>Halted: Idle</b></p> <p>Wait for the Define command to start the sequence.</p> <p>If the batch permit state is OK, then:</p> <ul style="list-style-type: none"> <li>▪ Increment the batch number, max 9999.</li> <li>▪ Record the cumulative totals.</li> <li>▪ Command available streams to initialise (via Define command to each stream batch task).</li> </ul> <p>Streams are available if:</p> <ul style="list-style-type: none"> <li>▪ Stream berth no = station berth no displays as STATION NO.</li> <li>▪ Stream control type = supervised.</li> <li>▪ Stream flow switching is enabled.</li> <li>▪ Stream batch permit is enabled.</li> <li>▪ Initialise the sampler.</li> </ul> <p>Proceed to the next stage.</p>
1	<p><b>Wait for Sampler to Reset</b></p> <p>If the Terminate command is issued, then:</p> <ul style="list-style-type: none"> <li>▪ Command the streams to terminate.</li> <li>▪ Go to the Batch Complete stage.</li> </ul> <p>Check the sampler status.</p> <p>If the sampler is reset or the stage times out, then:</p> <p>Proceed to the next stage.</p>
2	<p><b>Halted: Batch Defined</b></p> <p>If the Terminate command is issued, then:</p> <ul style="list-style-type: none"> <li>▪ Command the streams to terminate.</li> <li>▪ Go to the Batch Complete stage.</li> </ul> <p>Wait for the Start command then proceed to the next stage.</p>
3	<p><b>Wait for Streams to Start</b></p> <p>If the Terminate command is issued, then:</p> <ul style="list-style-type: none"> <li>▪ Command the streams to terminate.</li> <li>▪ Go to the Batch Complete stage.</li> </ul> <p>Wait for the streams for this berth to indicate they have reset and are ready to start the batch (stream status = Batch Monitor). Proceed to the next stage.</p>

Sequence Stage	Description
<b>4</b>	<p><b>Begin Startup</b></p> <p>Set the station flow switching setpoint = batch startup flowrate</p> <p>If the Terminate command is issued, then:</p> <ul style="list-style-type: none"> <li>▪ Command the streams to terminate.</li> <li>▪ Command the flow switching to shut down.</li> <li>▪ Go to the Wait Streams Close stage.</li> </ul> <p>If the Hold command is issued, then:</p> <ul style="list-style-type: none"> <li>▪ Command streams to hold</li> <li>▪ Set the station setpoint = 0</li> <li>▪ Command the flow switching to shut down.</li> <li>▪ Go to the Begin Hold stage.</li> </ul> <p>If a totals retrospective adjustment is required, then:</p> <ul style="list-style-type: none"> <li>▪ Carry out the adjustment.</li> </ul> <p>If the required batch total has been achieved (prematurely), then:</p> <ul style="list-style-type: none"> <li>▪ Set the station setpoint = 0</li> <li>▪ Command the flow switching to shut down.</li> <li>▪ Go to the Wait Streams Close stage.</li> </ul> <p>Wait for the station startup flowrate to be achieved.</p> <p>Proceed to the next stage.</p>
<b>5</b>	<p><b>In Startup</b></p> <p>Set the station flow switching setpoint = batch startup flowrate</p> <p>If the Terminate command is issued, then:</p> <ul style="list-style-type: none"> <li>▪ Command the streams to terminate.</li> <li>▪ Command the flow switching to shut down.</li> <li>▪ Go to the Wait Streams Close stage.</li> </ul> <p>If the Hold command is issued, then:</p> <ul style="list-style-type: none"> <li>▪ Command streams to hold</li> <li>▪ Set the station setpoint = 0</li> <li>▪ Command the flow switching to shut down.</li> <li>▪ Go to the Begin Hold stage.</li> </ul> <p>If a totals retrospective adjustment is required, then:</p> <ul style="list-style-type: none"> <li>▪ Carry out the adjustment.</li> </ul> <p>If the required batch total has been achieved, then:</p> <p>Set the station setpoint = 0</p> <ul style="list-style-type: none"> <li>▪ Command the flow switching to shut down.</li> <li>▪ Go to the Wait Streams Close stage.</li> </ul> <p>Wait for the station startup total to be achieved.</p> <p>Proceed to the next stage.</p>

Sequence Stage	Description
6	<p><b>Begin Nominal</b></p> <p>Set the station flow switching setpoint = batch nominal flowrate</p> <p>If the Terminate command is issued, then:</p> <ul style="list-style-type: none"> <li>▪ Command the streams to terminate.</li> <li>▪ Command the flow switching to shut down.</li> <li>▪ Go to the Wait Streams Close stage.</li> </ul> <p>If the Hold command is issued, then:</p> <ul style="list-style-type: none"> <li>▪ Command streams to hold</li> <li>▪ Set the station setpoint = 0</li> <li>▪ Command the flow switching to shut down.</li> <li>▪ Go to the Begin Hold stage.</li> </ul> <p>If the Top-Off command is issued, then:</p> <ul style="list-style-type: none"> <li>▪ Go to the Begin Top-off stage.</li> </ul> <p>If a totals retrospective adjustment is required, then:</p> <ul style="list-style-type: none"> <li>▪ Carry out the adjustment.</li> </ul> <p>If the required batch total has been achieved, then:</p> <ul style="list-style-type: none"> <li>▪ Set the station setpoint = 0</li> <li>▪ Command the flow switching to shut down.</li> <li>▪ Go to the Wait Streams Close stage.</li> </ul> <p>Wait for the station nominal flowrate to be achieved. Proceed to the next stage.</p>
7	<p><b>In Nominal</b></p> <p>Set the station flow switching setpoint = batch nominal flowrate</p> <p>If the Terminate command is issued, then:</p> <ul style="list-style-type: none"> <li>▪ Command the streams to terminate.</li> <li>▪ Command the flow switching to shut down.</li> <li>▪ Go to the Wait Streams Close stage.</li> </ul> <p>If the Hold command is issued, then:</p> <ul style="list-style-type: none"> <li>▪ Command streams to hold</li> <li>▪ Set the station setpoint = 0</li> <li>▪ Command the flow switching to shut down.</li> <li>▪ Go to the Begin Hold stage.</li> </ul> <p>If the Top-Off command is issued, then:</p> <ul style="list-style-type: none"> <li>▪ Go to the Begin Top-off stage.</li> </ul> <p>If a totals retrospective adjustment is required, then:</p> <ul style="list-style-type: none"> <li>▪ Carry out the adjustment.</li> </ul> <p>If the required batch total has been achieved, then:</p> <ul style="list-style-type: none"> <li>▪ Set the station setpoint = 0</li> <li>▪ Command the flow switching to shut down.</li> <li>▪ Go to the Wait Streams Close stage.</li> </ul> <p>Wait for the station nominal total (= batch – top-off) to be achieved. Proceed to the next stage.</p>

Sequence Stage	Description
<b>8</b>	<p><b>Begin Top-Off</b></p> <p>Set the station flow switching setpoint = batch top-off flowrate</p> <p>If the Terminate command is issued, then:</p> <ul style="list-style-type: none"> <li>▪ Command the streams to terminate.</li> <li>▪ Command the flow switching to shut down.</li> <li>▪ Go to the Wait Streams Close stage.</li> </ul> <p>If the Hold command is issued, then:</p> <ul style="list-style-type: none"> <li>▪ Command streams to hold</li> <li>▪ Set the station setpoint = 0</li> <li>▪ Command the flow switching to shut down.</li> <li>▪ Go to the Begin Hold stage.</li> </ul> <p>If a totals retrospective adjustment is required, then:</p> <ul style="list-style-type: none"> <li>▪ Carry out the adjustment.</li> </ul> <p>If the required batch total has been achieved, then:</p> <ul style="list-style-type: none"> <li>▪ Set the station setpoint = 0</li> <li>▪ Command the flow switching to shut down.</li> <li>▪ Go to the Wait Streams Close stage.</li> </ul> <p>Wait for the station top-off flowrate to be achieved.</p> <p>Proceed to the next stage.</p>
<b>9</b>	<p><b>In Top-Off</b></p> <p>Set the station flow switching setpoint = batch top-off flowrate</p> <p>If the Terminate command is issued, then:</p> <ul style="list-style-type: none"> <li>▪ Command the streams to terminate.</li> <li>▪ Command the flow switching to shut down.</li> <li>▪ Go to the Wait Streams Close stage.</li> </ul> <p>If the Hold command is issued, then:</p> <ul style="list-style-type: none"> <li>▪ Command streams to hold</li> <li>▪ Set the station setpoint = 0</li> <li>▪ Command the flow switching to shut down.</li> <li>▪ Go to the Begin Hold stage.</li> </ul> <p>If a totals retrospective adjustment is required, then:</p> <ul style="list-style-type: none"> <li>▪ Carry out the adjustment.</li> </ul> <p>Wait for the required batch total to be achieved, then:</p> <ul style="list-style-type: none"> <li>▪ Set the station setpoint = 0</li> <li>▪ Command the flow switching to shut down.</li> <li>▪ Go to the Wait Streams Close stage.</li> </ul>
<b>10</b>	<p><b>Begin Hold</b></p> <p>Set the station flow switching setpoint = 0</p> <p>If the Start command is issued, then:</p> <ul style="list-style-type: none"> <li>▪ Command the flow switching to start.</li> <li>▪ Go to the Begin Startup stage.</li> </ul> <p>If a totals retrospective adjustment is required, then:</p> <ul style="list-style-type: none"> <li>▪ Carry out the adjustment.</li> </ul> <p>Wait for the station flowrate to reduce to zero.</p> <p>Proceed to the next stage.</p>



Sequence Stage	Description
11	<p><b>Halted: In Hold</b></p> <p>Set the station flow switching setpoint = 0</p> <p>If the Terminate command is issued, then:</p> <ul style="list-style-type: none"> <li>▪ Command the streams to terminate.</li> <li>▪ Command the flow switching to shut down.</li> <li>▪ Go to the Wait Streams End stage.</li> </ul> <p>If the Start command is issued, then:</p> <ul style="list-style-type: none"> <li>▪ Command the flow switching to start.</li> <li>▪ Go to the Begin Startup stage.</li> </ul>
12	<p><b>Stream Batch</b></p> <p>Not currently configured</p>
13	<p><b>Wait for Streams Close</b></p> <p>Set the station flow switching setpoint = 0</p> <p>If the Terminate command is issued, then:</p> <ul style="list-style-type: none"> <li>▪ Command the streams to terminate.</li> <li>▪ Go to the Wait Streams End stage.</li> </ul> <p>Wait for the station flowrate to reduce to zero, then:</p> <ul style="list-style-type: none"> <li>▪ Command streams to terminate.</li> <li>▪ Command the sampler to stop.</li> <li>▪ Go to the Wait Streams End stage.</li> </ul>
14	<p><b>Wait for Streams End</b></p> <p>If the Terminate command is issued, then:</p> <ul style="list-style-type: none"> <li>▪ Command the sampler to stop.</li> <li>▪ If User stages are disabled, then: Go to the Batch Complete stage. else Go to the Wait Re-Calc stage.</li> </ul> <p>If the User stages are disabled, then:</p> <ul style="list-style-type: none"> <li>▪ Command the sampler to stop.</li> <li>▪ Wait for the streams to indicate they have individually returned to the Idle stage.</li> <li>▪ Go to the Batch Complete stage.</li> </ul> <p>else</p> <ul style="list-style-type: none"> <li>▪ Command the sampler to stop.</li> <li>▪ Wait for the streams to indicate they have individually reached the Wait Re-Calc Command stage.</li> <li>▪ Go to the Wait Re-Calc Command stage.</li> </ul>
15	<p><b>Batch Complete (Station)</b></p> <p>Go to the Idle stage.</p>
15	<p><b>Batch Complete (Stream)</b></p> <p>If the User stages are disabled, then:</p> <ul style="list-style-type: none"> <li>▪ Handle the totals</li> <li>▪ Go to the Idle stage.</li> </ul> <p>else</p> <ul style="list-style-type: none"> <li>▪ Go to the Wait Re-Calc Command stage.</li> </ul>
16	<p><b>Halted: Batch Monitor</b></p> <p>Used by supervised batching.</p> <p>If the Terminate command is issued, then:</p> <ul style="list-style-type: none"> <li>▪ Go to the Wait Streams Close stage.</li> </ul> <p>If a totals retrospective adjustment is required, then:</p> <ul style="list-style-type: none"> <li>▪ Carry out the adjustment.</li> </ul> <p>Wait for the next stage to be determined by the supervisory system.</p>

Sequence Stage	Description
17	<p><b>Halted: Wait Re-Calc Command</b></p> <p>If the Terminate command is issued, then:</p> <ul style="list-style-type: none"> <li>Command the streams to terminate.</li> <li>Go to the Terminated stage.</li> </ul> <p>If the Re-Calc command is issued, then:</p> <ul style="list-style-type: none"> <li>Command streams to re-calculate.</li> <li>Go to the Re-Calculating stage.</li> </ul>
18	<p><b>Re-Calculating</b></p> <p>If the Terminate command is issued, then:</p> <ul style="list-style-type: none"> <li>Command the streams to terminate.</li> <li>Go to the Terminated stage.</li> </ul> <p>Wait for the streams to indicate they have individually completed their re-calcs. Proceed to the Re-Calculate Complete stage.</p>
19	<p><b>Terminating</b></p> <p>If the Terminate command is issued, then:</p> <ul style="list-style-type: none"> <li>Go to the Idle stage.</li> </ul> <p>Wait for the streams to indicate they have individually returned to the Idle stage. Proceed to the Idle stage.</p>
20	<p><b>Halted: Re-Calculate Complete</b></p> <p>If the Terminate command is issued, then:</p> <ul style="list-style-type: none"> <li>Command the streams to terminate.</li> <li>Go to the Terminated stage.</li> </ul> <p>Wait for the stage to be changed externally.</p>

### C.2.1.2 Standalone Station Stages

Station batching is designed for a station/stream(s) combination within the same FloBoss S600+ flow computer. It monitors and controls a load using the required batch quantity together with the flow rate setpoints for start up, nominal and top off.

The system supports two modes of batch control:

- Standalone (the sequence is controlled by the S600+)
- Supervised, such as by a remote host computer.

The batch steps through a set of stages where the current stage is executed every second. The stage remains the same until an event (such as an operator command or the loading of a required volume) causes a change.

Standalone mode enables the FloBoss S600+ station computer to drive a batch from start to completion allowing for operator interaction along the way. *Table C-3* presents the sequence stages for standalone station batching.

*Table C-3. Standalone Station Batch Sequence Stages*

Stage	Display	Description
0	IDLE	Halted: idle, await Define command
1	WAIT SAMPLER	Wait for the sampler to reset
2	BATCH DEFINED	Halted: await Start command
3	WAIT STREAMS START	Wait for streams to start
4	BEGIN STARTUP	Set the startup flowrate, wait for station flowrate > startup flowrate

Stage	Display	Description
5	IN STARTUP	Wait for station total > startup volume
6	BEGIN NOMINAL	Set the nominal flowrate, wait for station flowrate > nominal flowrate
7	IN NOMINAL	Wait for station total > (specified – top-off) total
8	BEGIN TOPOFF	Set the top-off flowrate, wait for station flowrate > top-off flowrate
9	IN TOPOFF	Wait for station total > specified total
13	WAIT STREAMS CLOSE	Wait for station flowrate = zero
14	WAIT STREAMS END	Wait for streams to return Idle – wait for recalculation command if user stages are selected
15	BATCH COMPLETE	Print report, return to Idle
<b>Hold (Suspend Batch)</b>		
10	BEGIN HOLD	Suspend flow, wait for station flowrate = 0
11	IN HOLD	Halted: await Start or Terminate command
<b>Recalc</b>		<b>Note:</b> Only available if you select User Stages
17	WAIT RECALC CMND	Halted: await Recalc or Terminate command
18	RECALCULATING	Recalculating the totals
20	RECALC COMPLETE	Halted: await Terminate command
<b>Terminate</b>		
19	TERMINATING	Wait streams Idle, go to Station Idle

If user stages are enabled, you can use a LogiCalc to perform specific recalculation functions. The folder C:\Users\\Config600 3.3\lclib\batch includes a sample station batch logicalc.

### C.2.1.3 Supervised Station Stages

Supervised mode is intended to be controlled from a remote supervisory system, but the station still issues individual batch commands to the streams. *Table C-4* shows the batch sequence stages for a supervised station.

*Table C-4. Supervised Station Batch Sequence Stages*

Stage	Display	Description
0	IDLE	Halted: idle, await Define command
1	WAIT SAMPLER	Wait for the sampler to reset
2	BATCH DEFINED	Halted: await Start command
3	WAIT STREAMS START	Wait for streams to start
4	BEGIN STARTUP	Remain in Batch Monitor stage
5	IN STARTUP	Remain in Batch Monitor stage
6	BEGIN NOMINAL	Remain in Batch Monitor stage
7	IN NOMINAL	Remain in Batch Monitor stage
8	BEGIN TOPOFF	Remain in Batch Monitor stage
9	IN TOPOFF	Remain in Batch Monitor stage
16	BATCH MONITOR	Halted: await next stage from the supervisory system
13	WAIT STREAMS CLOSE	Wait for station flowrate = zero
14	WAIT STREAMS END	Wait for streams to return Idle – wait for recalculation command if user stages are selected
15	BATCH COMPLETE	Print report, return to Idle
<b>Hold (Suspend Batch)</b>		
10	BEGIN HOLD	Suspend flow, wait for station flowrate = 0

Stage	Display	Description
11	IN HOLD	Halted: await Start or Terminate command
	<b>Recalc</b>	<b>Note:</b> Only available if you select User Stages.
17	WAIT RECALC CMND	Halted: await Recalc or Terminate command
18	RECALCULATING	Recalculating the totals
20	RECALC COMPLETE	Halted: await Terminate command
	<b>Terminate</b>	
19	TERMINATING	Wait streams Idle, go to Station Idle

If user stages are enabled, a LogiCalc can be used to perform specific recalculation functions. The folder C:\Users\\Config600 3.3\lclib\batch includes a sample station batch logicalc.

### C.2.1.4 Standalone Stream Stages

Standalone mode is intended for a single stream to control a batch with no interaction with any other streams or supervisory sequences. *Table C-5* shows the batch sequence stages for standalone streams.

**Note:** Standalone stream stages require the use of the System Editor which is **only** available with the Config600 Pro software. For more information about implementing standalone stream stages, refer to **How To 83**.

The sequence stage logic is essentially the same as for the station, with the addition of:

- The Startup and Nominal stages can accept Nominal and Top-Off commands to move them on to the next stage.
- The Batch Complete and Re-Calc stages handle enabled user stages.

*Table C-5. Standalone Stream Batch Sequence Stages*

Stage	Display	Description
0	IDLE	Halted: idle, await Define command
1	WAIT SAMPLER	Wait for the sampler to reset
2	BATCH DEFINED	Halted: await Start command
4	BEGIN STARTUP	Set the startup flowrate, wait for station flowrate > startup flowrate
5	IN STARTUP	Wait for station total > startup volume
6	BEGIN NOMINAL	Set the nominal flowrate, wait for station flowrate > nominal flowrate
7	IN NOMINAL	Wait for station total > (specified – top-off) total
8	BEGIN TOPOFF	Set the top-off flowrate, wait for station flowrate > top-off flowrate
9	IN TOPOFF	Wait for station total > specified total
13	WAIT STREAMS CLOSE	Wait for station flowrate = zero
15	BATCH COMPLETE	Print report, return to Idle – wait for recalculation command if user stages are selected
	<b>Hold (Suspend Batch)</b>	
10	BEGIN HOLD	Suspend flow, wait for station flowrate = 0
11	IN HOLD	Halted: await Start or Terminate command
	<b>Recalc</b>	<b>Note:</b> Only available if you select User Stages
17	WAIT RECALC CMND	Halted: await Recalc or Terminate command
18	RECALCULATING	Recalculating the totals
20	RECALC COMPLETE	Halted: await Terminate command

Stage	Display	Description
<b>Terminate</b>		
19	TERMINATING	Transfer the batch totals from current to previous, go to Idle

If user stages are enabled, a LogiCalc can be used to perform specific recalculation functions. The folder C:\Users\\Config600 3.3\lclib\batch includes a sample stream batch logicalc.

### C.2.1.5 Supervised Stream Stages

Supervised mode is controlled either in conjunction with the S600+ station batch sequence or from a remote supervisory system. *Table C-6* shows the batch sequence stages for a supervised stream.

*Table C-6. Supervised Stream Batch Sequence Stages*

Stage	Display	Description
0	IDLE	Halted: idle, await Define command
1	WAIT SAMPLER	Wait for the sampler to reset
2	BATCH DEFINED	Halted: await Start command
3	WAIT STREAMS START	Wait for streams to start
4	BEGIN STARTUP	Remain in Batch Monitor stage
5	IN STARTUP	Remain in Batch Monitor stage
6	BEGIN NOMINAL	Remain in Batch Monitor stage
7	IN NOMINAL	Remain in Batch Monitor stage
8	BEGIN TOPOFF	Remain in Batch Monitor stage
9	IN TOPOFF	Remain in Batch Monitor stage
16	BATCH MONITOR	Halted: await next stage from the supervisory system
13	WAIT STREAMS CLOSE	Wait for station flowrate = zero
14	WAIT STREAMS END	Wait for streams to return Idle
15	BATCH COMPLETE	Print report, return to Idle
<b>Hold (Suspend Batch)</b>		
10	BEGIN HOLD	Suspend flow, wait for station flowrate = 0
11	IN HOLD	Halted: await Start or Terminate command
<b>Terminate</b>		
19	TERMINATING	Wait streams Idle, go to Station Idle

### C.2.2 Retrospective Batch Totals

The system applies retrospective totals adjustment at the stream.

Stream batching can run as a standalone (self contained) batch or as part of a station (supervised) batch. Both methods support retrospective K-factor or meter factor corrections at any stage during the batch after flow has started.

**Note:** Standalone stream stages require the use of the System Editor which is **only** available with the Config600 Pro software. For more information about implementing standalone stream stages, refer to **How To 83**.

By enabling user stages, you can also apply retrospective totals adjustments after a stream batch completes and before it returns to the Idle stage. This passes control to the Wait Recalc Command stage

rather than the Batch Complete stage (at the station). The sequence then halts at this stage until the Recalc command is received.

For example, if you modify the K-factor or meter factor after a prove, the system adjusts each batch total as follows:

$$\text{Adjusted total} = \text{batch total} * \text{ratio}$$

Where:

$$\text{ratio} = \text{old K-factor} / \text{new K-factor}$$

**or**

$$\text{ratio} = \text{new meter factor} / \text{old meter factor}$$

**or**

$$\text{ratio} = \text{GVC1} / \text{GV1}$$

where:

GVC1 = corrected gross volume for period 1.

GV1 = gross volume for period 1.

Further K-factor / meter factor changes do not invoke this correction but the S600+ uses the latest value in subsequent totalisations.

Retrospective adjustment is not applied to Indicated Volume totals.

---

**Note:** This adjustment method is not valid for applications using K-factor / meter factor linearisation because it is difficult to derive an accurate historic K-factor / meter factor.

---

### C.2.3 Batch Alarms

The system generates alarms at the following events:

- Batching not permitted.
- Pre-warning of batch approaching completion.
- Batch complete.

### C.2.4 Batch Ticket

Following is a sample batch ticket:

```

=====
1          BATCH TICKET - STATION 1
                                PRINT DATE/TIME: 02/04/2021 06:28:48
      (X)DELIVERY ( )RECEIPT TICKET 264
      (X)OFFICIAL ( )UNOFFICIAL
      ( )RECALCULATED ( )ACCEPTED

1. BATCH NUMBER                      16
2. TYPE OF LIQUID                      A CRUDE
3. METER CLOSING READING (DATE/TIME)    02/04/2021 06:28:45
4. METER OPENING READING (DATE/TIME)    02/04/2021 06:12:04
5. NET DELIVERY/RECEIPT TIME            0: 16      h : m
6. METER CLOSING READING IVOL           1072502    m3
7. METER OPENING READING IVOL           1068499    m3
8. IVOL                                 4002        m3
9. GUVOL                                4002.320    m3
10. AVERAGE FLOW RATE                  14394.0    m3/h
11. OBS DENSITY                         750.0000 ! kg/m3
12. OBS TEMP                            11.00 ! Deg.C
    
```

13. BASE DENSITY AT 15.0 Deg.C	750.0 ! kg/m3
14. AVERAGE WEIGHTED TEMPERATURE	1.00 Deg.C
15. AVERAGE WEIGHTED PRESSURE	5.00 barg
16. BS&W	60.000 ! %
17. BS&W CORRECTION FACTOR	60.000
18. NSVOL AT Deg.C	1604.130 Sm3
19. NSVOL AT 15.0 Deg.C	1604.130 Sm3
20. NETT MASS (METRIC)	1203.11 tonne
21. NETT MASS	2406.22 tonne

NON-NEGOTIABLE, NON-TRANSFERABLE  
 CHECKED FOR \_\_\_\_\_

BY: \_\_\_\_\_ DATE: \_\_\_\_\_

WITNESSED

BY: \_\_\_\_\_ DATE: \_\_\_\_\_

1 BATCH TICKET - STREAM 1

PRINT DATE/TIME: 02/04/2021 06:28:48

METER MANUFACTURER: METER MAN  
 METER MODEL: METER MODEL  
 METER SERIAL NUMBER: METER SERIAL NO  
 METER TAG NUMBER: METER TAG  
 METER SIZE: 0.00 mm  
 NOMINAL K-FACTOR: 100.0 pls/m3

PRIMARY FLOW COMPUTER: 00:A0:D8:F8:00:24

1. BATCH NUMBER	16
2. TYPE OF LIQUID	A CRUDE
3. METER CLOSING READING (DATE/TIME)	02/04/2021 06:28:45
4. METER OPENING READING (DATE/TIME)	02/04/2021 06:12:04
5. NET DELIVERY/RECEIPT TIME	0: 16 h : m
6. METER CLOSING READING IVOL	1072502 m3
7. METER OPENING READING IVOL	1068499 m3
8. IVOL	4002 m3
9. AVERAGE FLOW RATE	14394.0 m3/h
10. GUVOL	4002.320 m3
11. AVERAGE METER FACTOR	1.2536
12. OBS DENSITY	750.0000 ! kg/m3
13. OBS TEMP	11.00 ! Deg.C
14. BASE DENSITY AT 15.0 Deg.C	750.0 ! kg/m3
15. AVERAGE WEIGHTED TEMPERATURE	1.00 Deg.C
16. AVERAGE WEIGHTED PRESSURE	5.00 barg
17. CTLM	0.9876
18. CPLM	1.0101
19. BS&W	60.000 ! %
20. BS&W CORRECTION FACTOR	60.000
21. CCFM	0.9975
22. CCFM BSW	0.9975
23. NSVOL AT Deg.C	1604.130 Sm3
24. NSVOL AT 15.0 Deg.C	1604.130 Sm3
25. NETT MASS (METRIC)	1203.11 tonne
26. NETT MASS	2406.22 tonne

NON-NEGOTIABLE, NON-TRANSFERABLE  
 CHECKED FOR \_\_\_\_\_

BY: \_\_\_\_\_ DATE: \_\_\_\_\_

WITNESSED

BY: \_\_\_\_\_ DATE: \_\_\_\_\_

=====

### C.3 Batch Recalculation

---

Batch recalculation enables the recalculation of batch totals based on a newly modified observed density, observed temperature, observed pressure, meter temperature, meter pressure, or modified BS&W (for crude oil). It should be noted that the recalculation of totals takes into account the units and rounding option configured for the product.

When triggered by an operator-issued recalculation command, the system recalculates the totals for the selected batch ticket according to specific settings. You can run recalculation for a specific day for a selected batch, for either the current batch or for a chosen historical batch ticket. You can enter values for the density, temperature, pressure, meter temperature, meter pressure and BS&W manually or use the flow weighted average.

#### C.3.1 Displays

The following tables describe the displays associated with the batch totals recalculation. Access the displays through the S600+ front panel or web browser.

For station recalculations the menus can be found by navigating to **Operator>Station *n*>** (where “*n*” is the station number). For stream recalculations navigate to **Operator>Station *n*>** (where “*n*” is the stream number).

The BCH CURR BASE DENS (Station), BCH CURR BS&W (Station), BCH CURR RECALC (Station), BCH

CURR RESULTS (Station and Stream), BCH CURR MTR TEMP (Stream) and BCH CURR MTR PRESS (Stream) menu locations include the displays which deal with the current batch ticket.

The RECALL TICKET (Station), RECALL BASE DENS (Station), RECALL BS&W (Station), RECALL RECALC (Station), RECALL RESULTS (Station and Stream), RECALL MTR TEMP (Stream) and RECALL MTR PRESS (Stream) menu locations include the displays which deal with a recalled historic batch ticket.

Some of the displays behave differently although they are the same for both current and recalled batch tickets. These differences are described below. To distinguish between the CURRENT and the RECALL displays, their descriptions were prefixed with C. and R., respectively.

*Table C-7. BATCH CONTROL and RECALL TICKET Displays*

<b>Display</b>	<b>Description</b>
<b>TICKET NUMBER</b>	Identifies the batch ticket the recalculation will be performed on. The number must be a valid batch ticket. If viewed from the BATCH CONTROL menu this location indicates the number of the current/last ticket and cannot be changed. If viewed from the RECALL TICKET menu you can change the value of this location to select the desired batch ticket for which the calculations should be performed.
<b>BATCH NUMBER</b>	Sets the operator entered batch number



Display	Description
<b>DAY NUMBER</b>	Indicates the total number of days in the currently selected batch ticket
<b>OFFICIAL/ UNOFFICIAL</b>	Determines whether this is an official or unofficial batch. Valid values are OFFICIAL (the BATCH NUMBER increases by one) or UNOFFICIAL (the BATCH NUMBER is 0). This must be set before starting a batch. Found only a station level in the BATCH CONTROL menu.
<b>DELIVERY/ RECEIPT</b>	Determines whether this is a delivery or a receipt. Values: YES, NO. This must be set before starting a batch. Found only at station level in the BATCH CONTROL menu.

Table C-8. BCH CURR BASE DENS and RECALL BASE DENS Displays

Display	Description
<b>BASE DENSITY (BATCH)</b>	Shows the flow weighted average value for the selected batch. <b>Note:</b> This value is found <b>only</b> at the station level.
<b>RECALC BASE DENSITY</b>	Sets the base density value that the system uses in recalculations. The system uses this value <b>only</b> if you set the BASE DENSITY SOURCE field to <b>RECALC</b> . <b>Note:</b> This value is found <b>only</b> at the station level.
<b>BASE DENSITY SOURCE</b>	Sets the source for base density that the system uses for recalculations. Valid values are <b>ORIGINAL</b> (use the flow weighted average as the source for the base density) or <b>RECALC</b> (use the value in the RECALC BASE DENSITY field as the source for base density). The default is <b>ORIGINAL</b> . <b>Note:</b> This value is found <b>only</b> at the station level.
<b>BASE DENSITY (DAY NO.)</b>	Shows, for each day, the base density of the selected batch. <b>Note:</b> This value is found <b>only</b> at the station level.

Table C-9. STATION BCH CURR BS&W and RECALL BS&W Displays

Display	Description
<b>BS&amp;W (BATCH)</b>	Shows the BS&W flow weighted average value for the selected batch. <b>Note:</b> This value is found <b>only</b> at the station level.
<b>RECALC BS&amp;W</b>	Sets the BS&W value that the system uses in recalculations. <b>Note:</b> This value is found <b>only</b> at the station level.
<b>BS&amp;W SOURCE</b>	Sets the source for BS&W that the system uses for recalculations. Valid values are <b>ORIGINAL</b> (use the flow weighted average) or <b>RECALC</b> (use the value in the RECALC BS&W field). <b>Note:</b> This value is found <b>only</b> at the station level.
<b>BS&amp;W (DAY NO.)</b>	Shows, for each day, the BS&W of the selected batch. <b>Note:</b> This value is found <b>only</b> at the station level.

Table C-10. STATION BCH CURR MTR TEMP and RECALL METER TEMP Displays

Display	Description
---------	-------------

Display	Description
<b>MTR TEMP (BATCH)</b>	Shows the flow weighted average value for the selected batch. <b>Note:</b> This value is found <b>only</b> at the stream level.
<b>RECALC MTR TEMP</b>	Sets the observed temperature value that the system uses in recalculations. <b>Note:</b> This value is found <b>only</b> at the stream level.
<b>MTR TEMP SOURCE</b>	Sets the source for the meter temperature that the system uses for recalculations. Valid values are <b>ORIGINAL</b> (use the flow weighted average) or <b>MANUAL</b> (use the value set in the RECALC MTR TEMP field). <b>Note:</b> This value is found <b>only</b> at the stream level.
<b>MTR TEMP (DAY NO.)</b>	Shows, for each day, the meter temperature of the selected batch. <b>Note:</b> This value is found <b>only</b> at the stream level.
<b>MTR PRESS (BATCH)</b>	Shows the flow weighted average value for the selected batch. <b>Note:</b> This value is found <b>only</b> at the stream level.
<b>RECALC MTR PRESS</b>	Sets the meter pressure value that the system uses in recalculations. <b>Note:</b> This value is found <b>only</b> at the stream level.
<b>MTR PRESS SOURCE</b>	Sets the source for the meter pressure that the system uses for recalculations. Valid values are <b>ORIGINAL</b> (use the flow weighted average) or <b>RECALC</b> (use the value set in the RECALC MTR PRESS field). <b>Note:</b> This value is found <b>only</b> at the stream level.
<b>MTR PRESS (DAY NO.)</b>	Shows, for each day, the meter pressure of the selected batch. <b>Note:</b> This value is found <b>only</b> at the stream level.

Table C-11. BCH CURR RECALC and RECALL RECALC Displays

Display	Description
<b>RECALC COMMAND</b>	Enables the system to perform recalculation with the currently set values. Valid values are <b>YES</b> (enable) and <b>NO</b> (disable).
<b>ACCEPT COMMAND</b>	Marks the current values as accepted for the selected batch. Valid values are <b>ACCEPT</b> (prevent further recalculations) and <b>IDLE</b> (allow further recalculations). <b>Note:</b> Also a new Batch Ticket is generated which indicates that the recalculated values have been accepted.
<b>RECALC DAY</b>	Shows the day of the selected batch for which the recalculations will be performed. <b>Note:</b> This value is found <b>only</b> at the station level.
<b>DIAGNOSTIC</b>	Shows a diagnostic message for the batching and recalculation functionality.

Table C-12. STATION/STREAM BATCH CURR RESULTS and RECALL RESULTS Displays

Display	Description
---------	-------------

<b>Display</b>	<b>Description</b>
<b>OBS DENSITY</b>	Shows the observed density for each day of the selected batch ticket and the flow weighted average value for the whole batch. <b>Note:</b> This value is found <b>only</b> at the station level.
<b>OBS TEMP</b>	Shows the observed temperature for each day of the selected batch ticket and the flow weighted average value for the whole batch. <b>Note:</b> This value is found <b>only</b> at the station level.
<b>OBS PRESS</b>	Shows the observed pressure for each day of the selected batch ticket and the flow weighted average value for the whole batch. <b>Note:</b> This value is found <b>only</b> at the station level.
<b>BS&amp;W</b>	Shows the recalculated BS&W for each day of the selected batch ticket and the recalculated flow weighted average for the whole batch. <b>Note:</b> This value is found at <b>both</b> the stream and station levels.
<b>BASE DENSITY</b>	Shows the recalculated base density for each day of the selected batch ticket and the base flow weighted average for the whole batch. <b>Note:</b> This value is found <b>only</b> at the station level.
<b>BATCH IVOL/ GUVOL/GSVOL/ NSVOL/SWVOL</b>	Shows the recalculated volume totals for the currently selected batch ticket. It should be noted that the recalculation of totals takes into account the units and rounding option configured for the product. <b>Note:</b> This value is found at <b>both</b> the stream and station levels.
<b>BATCH MASS/ NMASS</b>	Shows the recalculated mass totals for the currently selected batch ticket. It should be noted that the recalculation of totals takes into account the units and rounding option configured for the product. <b>Note:</b> This value is found at <b>both</b> the stream and station levels.
<b>TOTAL HOURS</b>	Indicates the duration in hours of the currently selected batch. <b>Note:</b> This value is found at <b>both</b> the stream and station levels.
<b>TOTAL MINUTES</b>	Number of minutes elapsed in addition to the TOTAL HOURS location. <b>Note:</b> This value is found at <b>both</b> the stream and station levels.
<b>FLOWING HOURS</b>	Number of hours during which there was flow for the selected batch. <b>Note:</b> This value is found at <b>both</b> the stream and station levels.
<b>FLOWING MINUTES</b>	Number of minutes during which there was flow for the selected batch in addition to the FLOWING HOURS location. <b>Note:</b> This value is found at <b>both</b> the stream and station levels.
<b>IDLE HOURS</b>	Number of hours during which there was no flow for the selected batch. <b>Note:</b> This value is found at <b>both</b> the stream and station levels.

Display	Description
<b>IDLE MINUTES</b>	Number of minutes during which there was no flow for the selected batch in addition to the IDLE HOURS location. <b>Note:</b> This value is found at <b>both</b> the stream and station levels.
<b>MTR DENSITY</b>	This set of displays shows the recalculated meter density for each day of the selected batch ticket and the recalculated flow weighted average for the whole batch. <b>Note:</b> This value is found <b>only</b> at the stream level.
<b>MTR TEMP</b>	This set of displays shows the recalculated meter temperature for each day of the selected batch ticket and the recalculated flow weighted average for the whole batch. <b>Note:</b> This value is found <b>only</b> at the stream level.
<b>MTR PRESS</b>	This set of displays shows the recalculated meter pressure for each day of the selected batch ticket and the recalculated flow weighted average for the whole batch. <b>Note:</b> This value is found <b>only</b> at the stream level.
<b>BASE DENSITY</b>	This set of displays shows the recalculated base density for each day of the selected batch ticket and the recalculated flow weighted average for the whole batch. <b>Note:</b> This value is found <b>only</b> at the stream level.

### C.3.2 Batch Ticket

The system generates a batch ticket at the beginning of a batch. The system updates a ticket with new data and generates a new instance of the ticket under the REPORTS>BATCH TICKET location when a batch ends, when a recalculation occurs, or when you issue an Accept command on a selected ticket.

Each ticket has a number you can use for recalling the ticket. This number appears on the same row as the ( )DELIVERY or ( )RECEIPT TICKET flags and can be read from a generated batch ticket.

Use the Recall Ticket option to recall the latest instance of the batch ticket.

---

**Note:** Data copied from the meter contains values irrespective of whether that meter has been flowing. These include (but are not limited to) Average Meter Factor, Average K Factor, Average Meter Density, CTLM, CPLM and CCFM.

---

Following is an example of a batch ticket.

```

=====
1          BATCH TICKET - STATION 1
                                PRINT DATE/TIME: 02/04/2021 06:28:48
      (X)DELIVERY ( )RECEIPT TICKET 264
      (X)OFFICIAL ( )UNOFFICIAL
      ( )RECALCULATED ( )ACCEPTED
1. BATCH NUMBER                      16
2. TYPE OF LIQUID                      A CRUDE
3. METER CLOSING READING (DATE/TIME) 02/04/2021 06:28:45
4. METER OPENING READING (DATE/TIME) 02/04/2021 06:12:04
5. NET DELIVERY/RECEIPT TIME          0: 16      h : m

```

6. METER CLOSING READING IVOL	1072502	m3
7. METER OPENING READING IVOL	1068499	m3
8. IVOL	4002	m3
9. GUVOL	4002.320	m3
10. AVERAGE FLOW RATE	14394.0	m3/h
11. OBS DENSITY	750.0000	! kg/m3
12. OBS TEMP	11.00	! Deg.C
13. BASE DENSITY AT 15.0 Deg.C	750.0	! kg/m3
14. AVERAGE WEIGHTED TEMPERATURE	1.00	Deg.C
15. AVERAGE WEIGHTED PRESSURE	5.00	barg
16. BS&W	60.000	! %
17. BS&W CORRECTION FACTOR	60.000	
18. NSVOL AT Deg.C	1604.130	Sm3
19. NSVOL AT 15.0 Deg.C	1604.130	Sm3
20. NETT MASS (METRIC)	1203.11	tonne
21. NETT MASS	2406.22	tonne

NON-NEGOTIABLE, NON-TRANSFERABLE  
 CHECKED FOR \_\_\_\_\_

BY: \_\_\_\_\_ DATE: \_\_\_\_\_

WITNESSED

BY: \_\_\_\_\_ DATE: \_\_\_\_\_

1 BATCH TICKET - STREAM 1

PRINT DATE/TIME: 02/04/2021 06:28:48

METER MANUFACTURER: METER MAN  
 METER MODEL: METER MODEL  
 METER SERIAL NUMBER: METER SERIAL NO  
 METER TAG NUMBER: METER TAG  
 METER SIZE: 0.00 mm  
 NOMINAL K-FACTOR: 100.0 pls/m3

PRIMARY FLOW COMPUTER: 00:A0:D8:F8:00:24

1. BATCH NUMBER		16
2. TYPE OF LIQUID		A CRUDE
3. METER CLOSING READING (DATE/TIME)	02/04/2021 06:28:45	
4. METER OPENING READING (DATE/TIME)	02/04/2021 06:12:04	
5. NET DELIVERY/RECEIPT TIME	0: 16	h : m
6. METER CLOSING READING IVOL	1072502	m3
7. METER OPENING READING IVOL	1068499	m3
8. IVOL	4002	m3
9. AVERAGE FLOW RATE	14394.0	m3/h
10. GUVOL	4002.320	m3
11. AVERAGE METER FACTOR	1.2536	
12. OBS DENSITY	750.0000	! kg/m3
13. OBS TEMP	11.00	! Deg.C
14. BASE DENSITY AT 15.0 Deg.C	750.0	! kg/m3
15. AVERAGE WEIGHTED TEMPERATURE	1.00	Deg.C
16. AVERAGE WEIGHTED PRESSURE	5.00	barg
17. CTLM	0.9876	
18. CPLM	1.0101	
19. BS&W	60.000	! %
20. BS&W CORRECTION FACTOR	60.000	
21. CCFM	0.9975	
22. CCFM BSW	0.9975	
23. NSVOL AT Deg.C	1604.130	Sm3
24. NSVOL AT 15.0 Deg.C	1604.130	Sm3
25. NETT MASS (METRIC)	1203.11	tonne
26. NETT MASS	2406.22	tonne

NON-NEGOTIABLE, NON-TRANSFERABLE  
 CHECKED FOR \_\_\_\_\_

BY: \_\_\_\_\_ DATE: \_\_\_\_\_

WITNESSED

BY : \_\_\_\_\_ DATE : \_\_\_\_\_

=====

### C.3.3 Recalculating Batches

The S600+ can store data for up to eight historic batches. When the history is full, a new batch overwrites the oldest batch data. You cannot recalculate a batch after it's been overwritten, although you may still be able to view its reports depending on your reports settings.

Each batch can hold up to 20 days of data; you can adjust this using PCSetup. You can recall each batch in the history and adjust different batch parameters, based either on a certain day or on the whole batch. Each time you trigger a recalculation, the system generates a new batch report that shows the recalculated data for the whole batch.

The system saves batch data on a per day basis. A day is considered to start at the **base time 1** hour and is 24 hours long. To change the **base time 1** hour, select **System Settings** on the top menu and then select **Report Setup** on the left-hand side menu. Scroll to the **BASETIME 1** display and change the value.

This section gives step by step descriptions of the batching and batch recalculation procedures for the S600+. The batching procedure described here refers to the Volume Load batch type, but most of the steps apply to the other batch types, as well.

#### Configuring the Next Batch

To configure the settings for the next batch:

1. Select **Operator** from the top menu.
2. On the left side menu, select **Station 1>Bch Stack**.

Reports	Alarms	Current	Flow Rates	Totals	Operator
<b>S600</b> <ul style="list-style-type: none"> <li>■ Station 1                             <ul style="list-style-type: none"> <li>■ Ave T&amp;P</li> <li>■ Stat&amp;Ctrl</li> <li>■ Obs Dens Corr</li> <li>■ Avg Data 1-4</li> <li>■ Avg Data 5-8</li> <li>■ <b>Bch Stack</b></li> <li>■ Batch Interface</li> <li>■ Batch Control</li> <li>■ Bch Curr Base D</li> <li>■ Bch Curr Bs&amp;W</li> <li>■ Bch Curr Recalc</li> <li>■ Bch Curr Result</li> <li>■ Recall Ticket</li> <li>■ Recall Base Den</li> <li>■ Recall Bs&amp;W</li> <li>■ Recall Recalc</li> <li>■ Recall Results</li> <li>■ Product Table</li> <li>■ Densitometers</li> </ul> </li> <li>■ Stream 1</li> <li>■ Stream 2</li> </ul>					
		<b>BATCH SLOT 1</b> BATCH ID 1 PRODUCT 1 A CRUDE EDIT	<b>BATCH SLOT 2</b> BATCH ID 1 PRODUCT 2 B REFINED EDIT	<b>BATCH SLOT 3</b> BATCH ID 1 PRODUCT 3 D LUBE OILS EDIT	
		ROC Value: 0.00000000	LINE PACK Value: 0.00000000 Sm3	INTERFACE MODE Status: ADD TO NEXT	
		BATCH COMMAND Status: NOT_ACTND	STAGE NO. Status: IDLE	TICKET NUMBER Value: 0	
		C.BASE DENSITY BATCH 0.00000000 kg/m3	C.BASE DENSITY SOURC Status: ORIGINAL	C.RECALC BASE DENSIT Value: 0.00000000 kg/m3	

Figure C-8. Batch Configuration

3. Select **Batch Slot 1**.
4. Enter the **PRODUCT NUMBER**.
5. Enter the **BATCH QUANTITY**. Once this quantity has flowed through the meter, the batch ends.

---

**Note:** Refer to section [Batch Stack](#) for further details about editing the batch stack.

---

**Starting a Batch** To start a batch:

1. Select **Operator** from the top menu.
2. On the left side menu, select **Station 1>Batch Control**.
3. Scroll to the right until you see the **BATCH TYPE**, and set the Status to **VOL LOAD**.

---

**Note:** You can **only** change the BATCH TYPE while the batch is idle. It cannot be changed while the batch is running.

---

Reports	Alarms	Current	Flow Rates	Totals	Operator					
S600										
<ul style="list-style-type: none"> <li>■ Station 1                             <ul style="list-style-type: none"> <li>■ Ave T&amp;P</li> <li>■ Stat&amp;Ctrl</li> <li>■ Obs Dens Corr</li> <li>■ Avg Data 1-4</li> <li>■ Avg Data 5-8</li> <li>■ Bch Stack</li> <li>■ Batch Interface</li> <li>■ <b>Batch Control</b></li> <li>■ Bch Curr Base D</li> <li>■ Bch Curr Bs&amp;W</li> <li>■ Bch Curr Recalc</li> <li>■ Bch Curr Result</li> </ul> </li> </ul>						TOPOFF F/R Value: 0.00000000	SUPERVISED Status: NO	BATCH TYPE Status: VOL LOAD		

Figure C-9. Volume Load

- Under the same menu, navigate to the BATCH COMMAND display and set its Status to BATCH DEFINED.

**Note:** Setting the status to BATCH DEFINED generates the Batch Start report. You can view the report by selecting **Reports** on the top menu and then selecting **Batch Ticket** on the left side menu. This action also triggers a **Load Started** alarm. You can check this by selecting **Alarms** on the top menu.

Reports	Alarms	Current	Flow Rates	Totals	Operator					
S600										
<ul style="list-style-type: none"> <li>■ Station 1                             <ul style="list-style-type: none"> <li>■ Ave T&amp;P</li> <li>■ Stat&amp;Ctrl</li> <li>■ Obs Dens Corr</li> <li>■ Avg Data 1-4</li> <li>■ Avg Data 5-8</li> <li>■ Bch Stack</li> <li>■ Batch Interface</li> <li>■ <b>Batch Control</b></li> <li>■ Bch Curr Base D</li> <li>■ Bch Curr Bs&amp;W</li> <li>■ Bch Curr Recalc</li> <li>■ Bch Curr Result</li> </ul> </li> </ul>						BATCH COMMAND Status: ACCEPTED	STAGE NO. Status: BATCH DEFINED	TICKET NUMBER Value: 1		
		C. BASE DENSITY BATCH 750.00000000 kg/m3	C. BASE DENSITY SOURCE Status: ORIGINAL	C. RECALC BASE DENSITY Value: 0.00000000 kg/m3						

Figure C-10. Batch Defined

- From the same display, select the **START** command. The status on the **STAGE NO** display page changes to **IN NOMINAL**.

**Note:** Use of the **START** command is required **only** when the batch type is either **VOL LOAD** or **MASS LOAD**. **DIGIN**, **INTERFACE**, **BASETIME**, **CONT VOL LOAD**, and **CONT MASS LOAD** batch types only need the **DEFINE** command to start and run a batch.

### Stopping a Batch

You can stop a **VOL LOAD** batch type either manually or automatically. To stop the batch at any time, use the **TERMINATE** command:

- Select **Operator** from the top menu.
- On the left side menu, select **Station 1>Batch Control**.



3. On the **BATCH COMMAND** display change the status to **TERMINATE**.
4. For the batch to stop automatically, the **REQUIRED QUANTITY** must be achieved.

**Note:** The end of a batch generates a **BATCH END** ticket. To view the ticket, click **Reports** on the top menu and the click **Batch Ticket** on the left-hand side menu. Additionally, the end of a batch triggers a Load Complete alarm. You can check this by clicking on **Alarms** on the top menu.

### Viewing Batch Information

To view information about the running batch, select **Operator** on the top menu. Select **Station 1** on the left side menu to view the **Batch Control**, **Bch Curr Base Ds**, **Bch Curr Bs&W**, **Bch Curr Recalc**, and **Bch Curr Results** menus. These menus provide information regarding the current running batch or the last stopped batch.

BATCH COMMAND	STAGE NO.	TICKET NUMBER	DAY NUMBER	BATCH NUMBER	DELIVERY/RECIPT	OFFICIAL TICKET
Status: ACCEPTED	Status: BATCH DEFINED	Value: 1	Value: 1	Value: 1	Status: YES	Status: YES
C.BASE DENSITY	C.BASE DENSITY SOURCE	C.RECALC BASE DENSITY	C.BASE DENSITY	C.BASE DENSITY	C.BASE DENSITY	
BATCH	Status: ORIGINAL	Value: 0.0000000 kg/m3	DAY 01	DAY 03	DAY 05	
760.0000000 kg/m3		0.0000000 kg/m3	760.0000000 kg/m3	0.0000000 kg/m3	0.0000000 kg/m3	
			DAY 02	DAY 04	DAY 06	
			0.0000000 kg/m3	0.0000000 kg/m3	0.0000000 kg/m3	
C.B&W	C.B&W SOURCE	C.RECALC B&W	C.B&W	C.B&W	C.B&W	
BATCH	Status: ORIGINAL	Value: 0.0000000 %	DAY 01	DAY 03	DAY 05	
80.0000000 %		0.0000000 %	76.0000000 %	0.0000000 %	0.0000000 %	
			DAY 02	DAY 04	DAY 06	
			0.0000000 %	0.0000000 %	0.0000000 %	
C.RECALC COMMAND	C.ACCEPT COMMAND	C.RECALC DAY	DIAGNOSTIC			
Status: STOP	Status: STOP	Status: ALL	Status: OK			
C.OBS DENSITY	C.OBS DENSITY	C.OBS DENSITY	C.OBS DENSITY	C.OBS TEMP	C.OBS TEMP	C.OBS TEMP
DAY 01	DAY 03	DAY 05	BATCH	DAY 01	DAY 03	DAY 05
760.0000000 kg/m3	0.0000000 kg/m3	0.0000000 kg/m3	760.0000000 kg/m3	22.0000000 Deg.C	0.0000000 Deg.C	0.0000000 Deg.C
DAY 02	DAY 04	DAY 06	DAY 02	DAY 04	DAY 06	
0.0000000 kg/m3	0.0000000 kg/m3	0.0000000 kg/m3	0.0000000 Deg.C	0.0000000 Deg.C	0.0000000 Deg.C	

Figure C-11. Batch Information

To review data about historical batches, use the **Recall Ticket**, **Recall Base Dens**, **Recall Bs&W**, **Recall Recalc**, and **Recall Results** menus. You can find these menus by selecting **Operator > Station 1**. To see data for a batch, click on **Recall Ticket**. Go to the **TICKET NUMBER** display and change the value to the ticket number you wish to review. All the Recall menus update with information about the recalled ticket.

Reports	Home	Current	Flow Rates	Totals	Operator	Plant I/O	System Settings	Tech/Engineer	Calculations	Diags	Log Off																																																												
<table border="1"> <tr> <td>0. RECEIPT TICKET Value: 0</td> <td>0. BATCH NUMBER Value: 0</td> <td>0. DAY NUMBER Value: 0</td> <td></td> <td></td> <td></td> <td></td> <td></td> <td></td> <td></td> <td></td> <td></td> </tr> <tr> <td>0. BASE DENSITY BATCH: 0.00000000 kg/m3</td> <td>0. RECALC BASE DENS Status: ORIGINAL</td> <td>0. RECALC BASE DENS Value: 0.00000000 kg/m3</td> <td>0. BASE DENSITY DAY 01: 0.00000000 kg/m3 DAY 02: 0.00000000 kg/m3</td> <td>0. BASE DENSITY DAY 03: 0.00000000 kg/m3 DAY 04: 0.00000000 kg/m3</td> <td>0. BASE DENSITY DAY 05: 0.00000000 kg/m3 DAY 06: 0.00000000 kg/m3</td> <td></td> <td></td> <td></td> <td></td> <td></td> <td></td> </tr> <tr> <td>0. BS&amp;W BATCH: 0.00000000 %</td> <td>0. BS&amp;W POINTC Status: ORIGINAL</td> <td>0. RECALC BS&amp;W Value: 0.00000000 %</td> <td>0. BS&amp;W DAY 01: 0.00000000 % DAY 02: 0.00000000 %</td> <td>0. BS&amp;W DAY 03: 0.00000000 % DAY 04: 0.00000000 %</td> <td>0. BS&amp;W DAY 05: 0.00000000 % DAY 06: 0.00000000 %</td> <td></td> <td></td> <td></td> <td></td> <td></td> <td></td> </tr> <tr> <td>0. RECALC COORD Status: 00</td> <td>0. ACCEPT COORD Status: IDLE</td> <td>0. RECALC DAY Status: DAY 1</td> <td colspan="2">0. DIAGNOSTIC Status: ON</td> <td></td> <td></td> <td></td> <td></td> <td></td> <td></td> <td></td> </tr> <tr> <td>0. OBS DENSITY DAY 01: 0.00000000 kg/m3 DAY 02: 0.00000000 kg/m3</td> <td>0. OBS DENSITY DAY 03: 0.00000000 kg/m3 DAY 04: 0.00000000 kg/m3</td> <td>0. OBS DENSITY DAY 05: 0.00000000 kg/m3 DAY 06: 0.00000000 kg/m3</td> <td>0. OBS DENSITY BATCH: 0.00000000 kg/m3</td> <td>0. OBS TEMP DAY 01: 0.00000000 Deg.C DAY 02: 0.00000000 Deg.C</td> <td>0. OBS TEMP DAY 03: 0.00000000 Deg.C DAY 04: 0.00000000 Deg.C</td> <td>0. OBS TEMP DAY 05: 0.00000000 Deg.C DAY 06: 0.00000000 Deg.C</td> <td></td> <td></td> <td></td> <td></td> <td></td> </tr> </table>												0. RECEIPT TICKET Value: 0	0. BATCH NUMBER Value: 0	0. DAY NUMBER Value: 0										0. BASE DENSITY BATCH: 0.00000000 kg/m3	0. RECALC BASE DENS Status: ORIGINAL	0. RECALC BASE DENS Value: 0.00000000 kg/m3	0. BASE DENSITY DAY 01: 0.00000000 kg/m3 DAY 02: 0.00000000 kg/m3	0. BASE DENSITY DAY 03: 0.00000000 kg/m3 DAY 04: 0.00000000 kg/m3	0. BASE DENSITY DAY 05: 0.00000000 kg/m3 DAY 06: 0.00000000 kg/m3							0. BS&W BATCH: 0.00000000 %	0. BS&W POINTC Status: ORIGINAL	0. RECALC BS&W Value: 0.00000000 %	0. BS&W DAY 01: 0.00000000 % DAY 02: 0.00000000 %	0. BS&W DAY 03: 0.00000000 % DAY 04: 0.00000000 %	0. BS&W DAY 05: 0.00000000 % DAY 06: 0.00000000 %							0. RECALC COORD Status: 00	0. ACCEPT COORD Status: IDLE	0. RECALC DAY Status: DAY 1	0. DIAGNOSTIC Status: ON									0. OBS DENSITY DAY 01: 0.00000000 kg/m3 DAY 02: 0.00000000 kg/m3	0. OBS DENSITY DAY 03: 0.00000000 kg/m3 DAY 04: 0.00000000 kg/m3	0. OBS DENSITY DAY 05: 0.00000000 kg/m3 DAY 06: 0.00000000 kg/m3	0. OBS DENSITY BATCH: 0.00000000 kg/m3	0. OBS TEMP DAY 01: 0.00000000 Deg.C DAY 02: 0.00000000 Deg.C	0. OBS TEMP DAY 03: 0.00000000 Deg.C DAY 04: 0.00000000 Deg.C	0. OBS TEMP DAY 05: 0.00000000 Deg.C DAY 06: 0.00000000 Deg.C					
0. RECEIPT TICKET Value: 0	0. BATCH NUMBER Value: 0	0. DAY NUMBER Value: 0																																																																					
0. BASE DENSITY BATCH: 0.00000000 kg/m3	0. RECALC BASE DENS Status: ORIGINAL	0. RECALC BASE DENS Value: 0.00000000 kg/m3	0. BASE DENSITY DAY 01: 0.00000000 kg/m3 DAY 02: 0.00000000 kg/m3	0. BASE DENSITY DAY 03: 0.00000000 kg/m3 DAY 04: 0.00000000 kg/m3	0. BASE DENSITY DAY 05: 0.00000000 kg/m3 DAY 06: 0.00000000 kg/m3																																																																		
0. BS&W BATCH: 0.00000000 %	0. BS&W POINTC Status: ORIGINAL	0. RECALC BS&W Value: 0.00000000 %	0. BS&W DAY 01: 0.00000000 % DAY 02: 0.00000000 %	0. BS&W DAY 03: 0.00000000 % DAY 04: 0.00000000 %	0. BS&W DAY 05: 0.00000000 % DAY 06: 0.00000000 %																																																																		
0. RECALC COORD Status: 00	0. ACCEPT COORD Status: IDLE	0. RECALC DAY Status: DAY 1	0. DIAGNOSTIC Status: ON																																																																				
0. OBS DENSITY DAY 01: 0.00000000 kg/m3 DAY 02: 0.00000000 kg/m3	0. OBS DENSITY DAY 03: 0.00000000 kg/m3 DAY 04: 0.00000000 kg/m3	0. OBS DENSITY DAY 05: 0.00000000 kg/m3 DAY 06: 0.00000000 kg/m3	0. OBS DENSITY BATCH: 0.00000000 kg/m3	0. OBS TEMP DAY 01: 0.00000000 Deg.C DAY 02: 0.00000000 Deg.C	0. OBS TEMP DAY 03: 0.00000000 Deg.C DAY 04: 0.00000000 Deg.C	0. OBS TEMP DAY 05: 0.00000000 Deg.C DAY 06: 0.00000000 Deg.C																																																																	

Figure C-12. Batch Information

You can find the same menus at stream level as well.

**Notes:**

- To get a ticket number, select **Reports** on the top menu and access the **Batch Ticket** menu on the left hand side menu. Choose a report and on the header of the report you can see the ticket number next to the **RECEIPT TICKET** flag.
- Both the **Btch Curr** and the **Recall** menus have a similar layout.
- The **Bch Control/Recall Ticket** menus provide information about ticket number, batch number, the number of days elapsed since the start of the batch and the **ACCEPT** command.
- The **Bch Curr Base Dens/Recall Base Dens, Bch Curr Bs&W/Recall Bs&W, Bch Curr Mtr Temp/Recall Mtr Temp, Bch Curr Mtr Press/Recall Press** menus show information about input batch parameters such as **BASE DENSITY, BS&W, METER TEMPERATURE** and **METER PRESSURE**. The data is stored as a weighted average and is displayed on a per day basis. You can also change the values of any of these parameters to issue a recalculated batch ticket.
- The **Bch Curr Recalc/Recall Recalc** menus include the **RECALC COMMAND, the ACCEPT COMMAND, the RECALC DAY** and the **DIAGNOSTIC** display. These are used when performing a recalculation on the current or a historic batch ticket.
- The **Bch Curr Results/Recall Results** menus show information about the batch, such as quantities accumulated during the batch or recalculated quantities and the duration of the batch.

**Recalculating a Current Batch**

To recalculate a current batch:

1. **Select Operator** on the top menu.

2. Select **Station 1>Batch Control** on the left-hand side menu. The **TICKET NUMBER** display shows the ticket number of the current running batch or of the previously stopped batch, if no batch is running now.

Reports	Alarms	Current	Flow Rates	Totals	Operator						
S600											
<ul style="list-style-type: none"> <li>■ Station 1                             <ul style="list-style-type: none"> <li>■ Ave T&amp;P</li> <li>■ Stat&amp;Ctrl</li> <li>■ Obs Dens Corr</li> <li>■ Avg Data 1-4</li> <li>■ Avg Data 5-8</li> <li>■ Bch Stack</li> <li>■ Batch Interface</li> <li>■ <b>Batch Control</b></li> <li>■ Bch Curr Base D</li> <li>■ Bch Curr Bs&amp;W</li> <li>■ Bch Curr Recalc</li> <li>■ Bch Curr Result</li> </ul> </li> </ul>						BATCH COMMAND Status: ACCEPTED		STAGE NO. Status: IDLE		TICKET NUMBER Value: 2	
		C.BASE DENSITY BATCH 750.00000000 kg/m3		C.BASE DENSITY SOURCE Status: ORIGINAL		C.RECALC BASE DENSITY Value: 0.00000000 kg/m3					

Figure C-13. Ticket Number

3. Select **Bch Curr Recalc** on the left side menu and scroll to the **RECALC DAY** display. Select the day you wish to recalculate (the example uses Day 2).

---

**Note:** If the current batch is running you **cannot** recalculate **either** the current day or the whole batch.

---

Reports	Alarms	Current	Flow Rates	Totals	Operator						
S600											
<ul style="list-style-type: none"> <li>■ Station 1                             <ul style="list-style-type: none"> <li>■ Ave T&amp;P</li> <li>■ Stat&amp;Ctrl</li> <li>■ Obs Dens Corr</li> <li>■ Avg Data 1-4</li> <li>■ Avg Data 5-8</li> <li>■ Bch Stack</li> <li>■ Batch Interface</li> <li>■ Batch Control</li> <li>■ Bch Curr Base D</li> <li>■ Bch Curr Bs&amp;W</li> <li>■ <b>Bch Curr Recalc</b></li> <li>■ Bch Curr Result</li> </ul> </li> </ul>						C.RECALC COMMAND Status: NO		C.ACCEPT COMMAND Status: IDLE		C.RECALC DAY Status: DAY 2	
		C.OBS DENSITY DAY 01 750.00000000 kg/m3		C.OBS DENSITY DAY 03 750.00000000 kg/m3		C.OBS DENSITY DAY 05 0.00000000 kg/m3					
		DAY 02 750.00000000 kg/m3		DAY 04 0.00000000 kg/m3		DAY 06 0.00000000 kg/m3					

Figure C-14. Recalculate Day

4. To recalculate the batch with a new base density for day 2, go to the Operator menu, select **Bch Curr Base Dens**, and scroll to the **BASE DENSITY (DAY NO)** displays. This shows the original value for the base density on a given day or for the whole batch.
5. Scroll to the **BASE DENSITY SOURCE** display and change the status from **ORIGINAL** to **RECALC**.
6. To change the base density, scroll to the **RECALC BASE DENSITY** display and enter a new value.

The screenshot shows the 'Operator' menu selected on the top navigation bar. The left sidebar menu has 'Bch Curr Base D' highlighted. The main display area shows a table with columns for 'C.BASE DENSITY', 'C.BASE DENSITY SOURCE', 'C.RECALC BASE DENSITY', and 'C.BASE DENSITY' for six days (DAY 01 to DAY 06). The 'C.RECALC BASE DENSITY' column shows a status of 'RECALC' and a value of '800.00000000 kg/m3'.

Figure C-15. Recalculate Base Density

7. Select **Bch Curr Recalc** on the left side menu. and scroll to the **RECALC COMMAND** display.
8. Set the status to **YES**. This triggers a recalculation on the selected batch with the changed parameter. A new batch ticket is triggered, reflecting the changes for the whole batch. The displays under the Bch Curr menus update with the new data. That is, the density on the selected day match the one we've entered previously, and the volumes for that day are recalculated. The totals for that batch update correspondingly.

The screenshot shows the 'Operator' menu selected on the top navigation bar. The left sidebar menu has 'Bch Curr Base D' highlighted. The main display area shows a table with columns for 'C.RECALC COMMAND', 'C.ACCEPT COMMAND', and 'C.RECALC DAY'. The 'C.RECALC COMMAND' column shows a status of 'NO'. Below this, there are columns for 'C.OBS DENSITY' for six days (DAY 01 to DAY 06). The 'C.OBS DENSITY' column shows values of '750.00000000 kg/m3' for DAY 01 and DAY 02, and '0.00000000 kg/m3' for DAY 03, DAY 04, DAY 05, and DAY 06.

Figure C-16. Recalculate Command

**Note:** Perform steps 1 through 8 for any of the other parameters which can be modified.

### Recalculating an Historic Batch

To recalculate an historic batch:

**Note:** This procedure assumes that at least one batch is available in batch history.

1. To recalculate a historic batch ticket, you need the batch ticket number. To get the batch ticket number, go to **Reports** on the top menu and access **Batch Ticket** on the left side menu. Choose a report. The header of the report displays the ticket number next to the **RECEIPT TICKET** flag.
2. Go to **Operator** on the top menu, then **Station 1** on the left side menu and click on **Recall Ticket**. On the **TICKET NUMBER** display enter the batch ticket number from the batch ticket. Once

you've entered the ticket number the **Recall** displays updates with the data particular to that ticket.

Reports	Alarms	Current	Flow Rates	Totals	Operator
<b>S600</b> Station 1 Ave T&P Stat&Ctrl Obs Dens Corr Avg Data 1-4 Avg Data 5-8 Bch Stack Batch Interface Batch Control Bch Curr Base D Bch Curr Bs&W Bch Curr Recalc Bch Curr Result <b>Recall Ticket</b> Recall Base Den Recall Bs&W Recall Recalc Recall Results Product Table					
R. TICKET NUMBER		R. BATCH NUMBER		R. DAY NUMBER	
Value: 2		Value: 1		Value: 3	
R. BASE DENSITY		R. BASE DENSITY SOURCE		R. RECALC BASE DENSITY	
BATCH 750.00000000 kg/m3		Status: ORIGINAL		Value: 750.00000000 kg/m3	
R. BS&W		R. BS&W SOURCE		R. RECALC BS&W	
BATCH 80.00000000 ‡		Status: ORIGINAL		Value: 80.00000000 ‡	

Figure C-17. Recall Ticket Number

- Go to the Recall Recalc menu and scroll to the RECALC DAY display. Select the day to recalculate. This example selects day two and recalculates the batch with an new base density for day two.

**Note:** If the batch you've recalled is running you **cannot** recalculate **either** the current day or the whole batch.

Reports	Alarms	Current	Flow Rates	Totals	Operator	Plant I/O	System Setting
<b>S600</b> Station 1 Ave T&P Stat&Ctrl Obs Dens Corr Avg Data 1-4 Avg Data 5-8 Bch Stack Batch Interface Batch Control Bch Curr Base D Bch Curr Bs&W Bch Curr Recalc Bch Curr Result Recall Ticket Recall Base Den Recall Bs&W <b>Recall Recalc</b> Recall Results Product Table							
R. RECALC COMMAND		R. ACCEPT COMMAND		R. RECALC DAY		DIAGNOSTIC	
Status: NO		Status: IDLE		Status: DAY 2		Status: OK	
R. OBS DENSITY		R. OBS DENSITY		R. OBS DENSITY		R. OBS DENSITY	
DAY 01 750.00000000 kg/m3		DAY 03 750.00000000 kg/m3		DAY 05 0.00000000 kg/m3		BATCH 750.00000000 kg/m3	
DAY 02 750.00000000 kg/m3		DAY 04 0.00000000 kg/m3		DAY 06 0.00000000 kg/m3			
STN01 PRODUCT REG		DENSITY UNITS		DENSITY UNITS		DENSITY UNITS	
STATION 01 2		PRODUCT 1 KG/M3		PRODUCT 3 KG/M3		PRODUCT 5 KG/M3	
		PRODUCT 2 KG/M3		PRODUCT 4 KG/M3		PRODUCT 6 KG/M3	

Figure C-18. Day Selection

- To see the original value for the base density on a given day or for the whole batch, go to **Operator > Station 1 > Recall Base Density** and scroll to the **BASE DENSITY (DAY NO.)** displays.

Reports	Alarms	Current	Flow Rates	Totals	Operator	Plant I/O	System Settings	Tech/Engineer	Calculations																		
<div style="display: flex;"> <div style="width: 25%; background-color: #000080; color: white; padding: 5px;"> <p>S600</p> <ul style="list-style-type: none"> <li>■ Station 1</li> <li>■ Ave T&amp;P</li> <li>■ Stat&amp;Ctrl</li> <li>■ Obs Dens Corr</li> <li>■ Avg Data 1-4</li> <li>■ Avg Data 5-8</li> <li>■ Bch Stack</li> <li>■ Batch Interface</li> <li>■ Batch Control</li> <li>■ Bch Curr Base D</li> <li>■ Bch Curr Bs&amp;W</li> <li>■ Bch Curr Recalc</li> <li>■ Bch Curr Result</li> <li>■ Recall Ticket</li> <li style="border: 1px solid red;">■ Recall Base Den</li> <li>■ Recall Bs&amp;W</li> <li>■ Recall Recalc</li> <li>■ Recall Results</li> <li>■ Product Table</li> </ul> </div> <table border="1" style="width: 75%; border-collapse: collapse;"> <tr> <td style="width: 25%;">R.BASE DENSITY BATCH 780.00000000 kg/m3</td> <td style="width: 25%;">R.BASE DENSITY SOURCE Status: ORIGINAL</td> <td style="width: 25%;">R.RECALC BASE DENSITY Value: 700.00000000 kg/m3</td> <td style="width: 25%;">R.BASE DENSITY DAY 01 780.00000000 kg/m3 DAY 02 780.00000000 kg/m3</td> <td style="width: 25%;">R.BASE DENSITY DAY 03 780.00000000 kg/m3 DAY 04 0.00000000 kg/m3</td> <td style="width: 25%;">R.BASE DENSITY DAY 05 0.00000000 kg/m3 DAY 06 0.00000000 kg/m3</td> </tr> <tr> <td>R.BS&amp;W BATCH 80.00000000 †</td> <td>R.BS&amp;W SOURCE Status: ORIGINAL</td> <td>R.RECALC BS&amp;W Value: 80.00000000 †</td> <td>R.BS&amp;W DAY 01 80.00000000 † DAY 02 80.00000000 †</td> <td>R.BS&amp;W DAY 03 80.00000000 † DAY 04 0.00000000 †</td> <td>R.BS&amp;W DAY 05 0.00000000 † DAY 06 0.00000000 †</td> </tr> <tr> <td>R.RECALC COMMAND Status: NO</td> <td>R.ACCEPT COMMAND Status: IDLE</td> <td>R.RECALC DAY Status: DAY 2</td> <td>DIAGNOSTIC</td> <td>Status: OFF</td> <td></td> </tr> </table> </div>										R.BASE DENSITY BATCH 780.00000000 kg/m3	R.BASE DENSITY SOURCE Status: ORIGINAL	R.RECALC BASE DENSITY Value: 700.00000000 kg/m3	R.BASE DENSITY DAY 01 780.00000000 kg/m3 DAY 02 780.00000000 kg/m3	R.BASE DENSITY DAY 03 780.00000000 kg/m3 DAY 04 0.00000000 kg/m3	R.BASE DENSITY DAY 05 0.00000000 kg/m3 DAY 06 0.00000000 kg/m3	R.BS&W BATCH 80.00000000 †	R.BS&W SOURCE Status: ORIGINAL	R.RECALC BS&W Value: 80.00000000 †	R.BS&W DAY 01 80.00000000 † DAY 02 80.00000000 †	R.BS&W DAY 03 80.00000000 † DAY 04 0.00000000 †	R.BS&W DAY 05 0.00000000 † DAY 06 0.00000000 †	R.RECALC COMMAND Status: NO	R.ACCEPT COMMAND Status: IDLE	R.RECALC DAY Status: DAY 2	DIAGNOSTIC	Status: OFF	
R.BASE DENSITY BATCH 780.00000000 kg/m3	R.BASE DENSITY SOURCE Status: ORIGINAL	R.RECALC BASE DENSITY Value: 700.00000000 kg/m3	R.BASE DENSITY DAY 01 780.00000000 kg/m3 DAY 02 780.00000000 kg/m3	R.BASE DENSITY DAY 03 780.00000000 kg/m3 DAY 04 0.00000000 kg/m3	R.BASE DENSITY DAY 05 0.00000000 kg/m3 DAY 06 0.00000000 kg/m3																						
R.BS&W BATCH 80.00000000 †	R.BS&W SOURCE Status: ORIGINAL	R.RECALC BS&W Value: 80.00000000 †	R.BS&W DAY 01 80.00000000 † DAY 02 80.00000000 †	R.BS&W DAY 03 80.00000000 † DAY 04 0.00000000 †	R.BS&W DAY 05 0.00000000 † DAY 06 0.00000000 †																						
R.RECALC COMMAND Status: NO	R.ACCEPT COMMAND Status: IDLE	R.RECALC DAY Status: DAY 2	DIAGNOSTIC	Status: OFF																							

Figure C-19. Base Density Display

5. Scroll to the **BASE DENSITY SOURCE** display and change the status from **ORIGINAL** to **RECALC**.
6. To change the base density, scroll to the **RECALC BASE DENSITY** display and enter a new value.

Reports	Alarms	Current	Flow Rates	Totals	Operator									
<div style="display: flex;"> <div style="width: 25%; background-color: #000080; color: white; padding: 5px;"> <p>S600</p> <ul style="list-style-type: none"> <li>■ Station 1</li> <li>■ Ave T&amp;P</li> <li>■ Stat&amp;Ctrl</li> <li>■ Obs Dens Corr</li> <li>■ Avg Data 1-4</li> <li>■ Avg Data 5-8</li> <li>■ Bch Stack</li> <li>■ Batch Interface</li> <li>■ Batch Control</li> <li>■ Bch Curr Base D</li> <li>■ Bch Curr Bs&amp;W</li> <li>■ Bch Curr Recalc</li> <li>■ Bch Curr Result</li> <li>■ Recall Ticket</li> <li style="border: 1px solid red;">■ Recall Base Den</li> <li>■ Recall Bs&amp;W</li> <li>■ Recall Recalc</li> <li>■ Recall Results</li> <li>■ Product Table</li> </ul> </div> <table border="1" style="width: 75%; border-collapse: collapse;"> <tr> <td style="width: 25%;">R.BASE DENSITY BATCH 780.00000000 kg/m3</td> <td style="width: 25%;">R.BASE DENSITY SOURCE Status: RECALC</td> <td style="width: 25%;">R.RECALC BASE DENSITY Value: 700.00000000 kg/m3</td> </tr> <tr> <td>R.BS&amp;W BATCH 80.00000000 †</td> <td>R.BS&amp;W SOURCE Status: ORIGINAL</td> <td>R.RECALC BS&amp;W Value: 80.00000000 †</td> </tr> <tr> <td>R.RECALC COMMAND Status: NO</td> <td>R.ACCEPT COMMAND Status: IDLE</td> <td>R.RECALC DAY Status: DAY 2</td> </tr> </table> </div>						R.BASE DENSITY BATCH 780.00000000 kg/m3	R.BASE DENSITY SOURCE Status: RECALC	R.RECALC BASE DENSITY Value: 700.00000000 kg/m3	R.BS&W BATCH 80.00000000 †	R.BS&W SOURCE Status: ORIGINAL	R.RECALC BS&W Value: 80.00000000 †	R.RECALC COMMAND Status: NO	R.ACCEPT COMMAND Status: IDLE	R.RECALC DAY Status: DAY 2
R.BASE DENSITY BATCH 780.00000000 kg/m3	R.BASE DENSITY SOURCE Status: RECALC	R.RECALC BASE DENSITY Value: 700.00000000 kg/m3												
R.BS&W BATCH 80.00000000 †	R.BS&W SOURCE Status: ORIGINAL	R.RECALC BS&W Value: 80.00000000 †												
R.RECALC COMMAND Status: NO	R.ACCEPT COMMAND Status: IDLE	R.RECALC DAY Status: DAY 2												

Figure C-20. Base Density Display

7. Select **Operator > Station 1 > Recall Recalc** and set the status on the RECALC COMMAND display to **YES**. This triggers a recalculation on the selected batch with the changed parameter. A new batch ticket will be triggered, reflecting the changes for the whole batch. The displays under the **Recall** menus update with the new data. That is, the density on the selected day will match the one we've entered previously and the volumes for that day will be recalculated. The totals for that batch update correspondingly.

Reports	Alarms	Current	Flow Rates	Totals	Operator	Plant I/O	System Setting
S600							
<ul style="list-style-type: none"> <li>■ Station 1                             <ul style="list-style-type: none"> <li>■ Ave T&amp;P</li> <li>■ Stat&amp;Ctrl</li> <li>■ Obs Dens Corr</li> <li>■ Avg Data 1-4</li> <li>■ Avg Data 5-8</li> <li>■ Bch Stack</li> <li>■ Batch Interface</li> <li>■ Batch Control</li> <li>■ Bch Curr Base D</li> <li>■ Bch Curr Bs&amp;W</li> <li>■ Bch Curr Recalc</li> <li>■ Bch Curr Result</li> <li>■ Recall Ticket</li> <li>■ Recall Base Den</li> <li>■ Recall Bs&amp;W</li> <li>■ Recall Recalc</li> <li>■ Recall Results</li> <li>■ Product Table</li> </ul> </li> </ul>							
R.RECALC COMMAND Status: NO		R.ACCEPT COMMAND Status: IDLE		R.RECALC DAY Status: DAY 2		DIAGNOSTIC Status: OK	
R.OBS DENSITY DAY 01 750.00000000 kg/m3 DAY 02 750.00000000 kg/m3		R.OBS DENSITY DAY 03 750.00000000 kg/m3 DAY 04 0.00000000 kg/m3		R.OBS DENSITY DAY 05 0.00000000 kg/m3 DAY 06 0.00000000 kg/m3		R.OBS DENSITY BATCH 750.00000000 kg/m3	
STN01 PRODUCT REG STATION 01 2		DENSITY UNITS PRODUCT 1 KG/M3 PRODUCT 2 KG/M3		DENSITY UNITS PRODUCT 3 KG/M3 PRODUCT 4 KG/M3		DENSITY UNITS PRODUCT 5 KG/M3 PRODUCT 6 KG/M3	

Figure C-21. Base Density Display

---

**Note:** Perform steps 1 through 7 for any of the other parameters which can be modified.

---

## C.4 Flow Switching

Flow switching is a station-based function that the batching process uses. In a standalone mode, flow switching determines how many streams are required to flow in order to maintain a required overall flowrate, depending on the availability of each stream.

If a stream fails, the stream can be closed and a new available stream given its remaining total.

Regulating flow is achieved by passing flowrate setpoints to the streams to control flowrate using PID control to drive flow control valves.

---

**Note:** Station flow switching calculations require that you configure **stream** flow switching calculations.

---

### C.4.1 Station Flow Switching Setup

Flow switching settings define the method and parameters to determine which streams should open and close. You can set up flow switching for a station and then disable it until you need this option.

1. Select **Flow Switching** from the hierarchy menu. The Flow Switching screen displays.

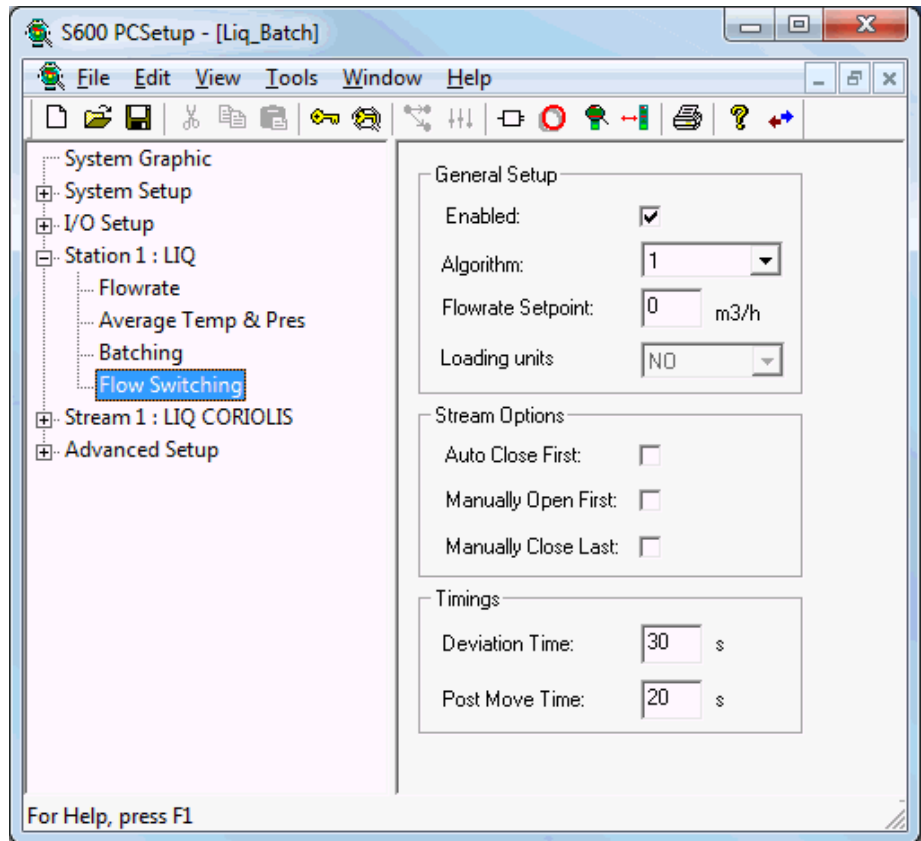

Figure C-22. Station Flow Switching screen

2. Complete the following fields.

Field	Description
<b>Enabled</b>	Disables flow switching for the station. The default is checked (flow switching is <b>Enabled</b> ).
<b>Algorithm</b>	Sets the algorithm to open and close streams. The default is <b>1</b> .
<b>Flowrate Setpoint</b>	Sets, if applicable, the required station flowrate.
<b>Loading Units</b>	Identifies whether the Measured Flowrate is Mass (=1) or Volume (=0) units. The default is <b>Volume</b> .
<b>Auto Close First</b>	Identifies whether to close highest priority stream first (checked) or to close lowest priority stream first. <b>Note:</b> This does not apply to Algorithm 1.
<b>Manually Open First</b>	Opens the first stream manually if selected.
<b>Manually Close Last</b>	Closes the last stream manually if selected.
<b>Deviation Time</b>	Sets the minimum time the flowrate must be above or below the limit before automatically opening or closing a stream.
<b>Post Move Time</b>	Sets a delay time after opening or closing a valve before moving to the monitor flow stage.

3. Click in the hierarchy menu when you finish defining settings. A confirmation dialog displays.

4. Click **Yes** to apply your changes. The PCSetup screen displays.



## C.4.2 Stream Flow Switching Setup

Flow switching settings define the priorities and number of valves present, as well as control loop specifics. You can set up flow switching for a stream and then disable it until you need this option.

1. Select **Flow Switching** from the hierarchy menu. The Flow Switching screen displays.

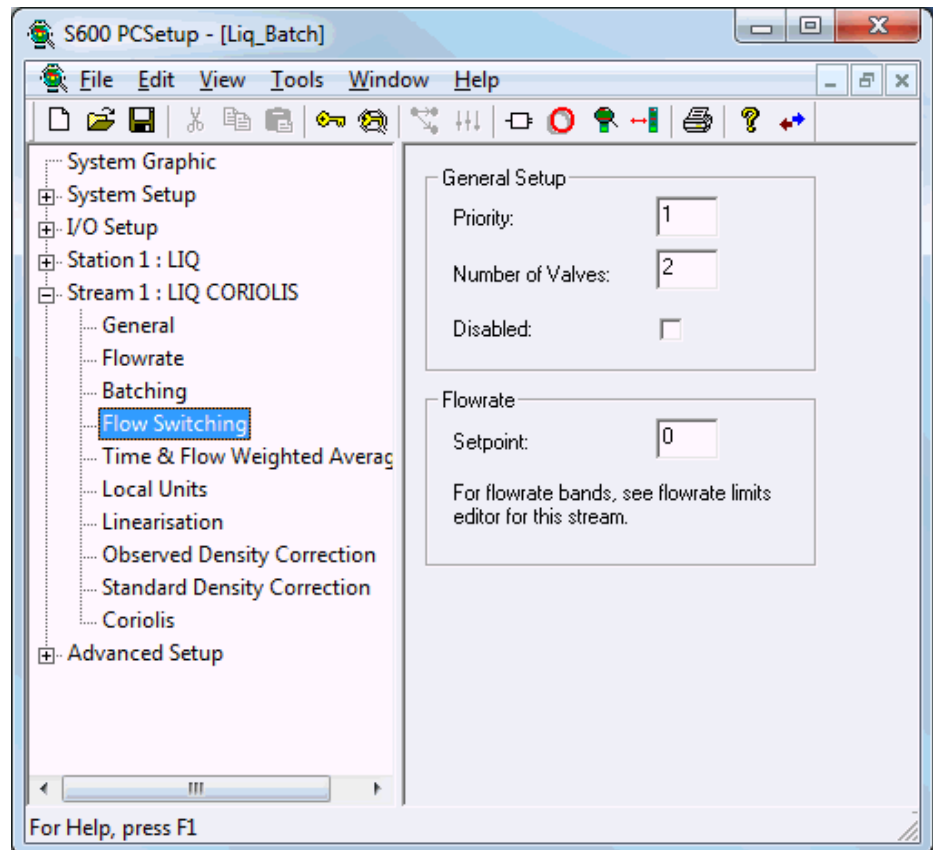

Figure C-23. Stream Flow Switching screen

2. Complete the following fields.

Field	Description
<b>Priority</b>	Sets the priority of the stream. The higher the number, the higher the stream's priority. For example, 2 has priority over 1, and 3 has priority over 2. The default is <b>1</b> .
<b>Number of Valves</b>	Sets the number of valves the stream controls. The default is <b>2</b> .
<b>Disabled</b>	Disables flow switching for the selected stream. The default is unchecked (flow switching is <b>disabled</b> ).
<b>Setpoint</b>	Sets, if applicable, the ideal flowrate required on the selected stream.
<b>PID Loop</b>	Identifies the PID loop used to control the flowrate of the selected stream. Click ▼ to display all valid options. The default is <b>I/O 01 PID CNTRL 1</b> . <b>Note:</b> Define flowrate band settings for each stream on the Flowrate screen.

3. Click in the hierarchy menu when you finish defining settings. A confirmation dialog displays.
4. Click **Yes** to apply your changes. The PCSetup screen displays.

### C.4.3 Flow Switching Algorithms

This section details flow switching algorithms, which provide alternative rules for deciding which streams to use:

- Algorithm 1 compares the stream flowrate against its low/high limits.
- Algorithm 2 compares the station flowrate against the summated low/high limits.
- Algorithm 3 compares the station flowrate setpoint against the summated low/high limits.
- Algorithm 4 is the same as algorithm 3 and also distributes a setpoint to each open stream to spread the flowrate evenly.

**Algorithm 1** For each open stream, the system compares the observed flow rate against the low and high bands. If the lowest priority stream's flow rate is **less** than its low band for the specified Deviation Time and **more** than one stream is online, the stream closes. If only one stream is online, flow switching takes no action.

If the lowest priority stream's high band is **exceeded** for the specified Deviation Time and at least one other stream is available for opening, the flow switching then opens the available highest priority stream. If no stream is available for opening, an alarm occurs but flow switching performs no switching actions.

This algorithm requires you to carefully initialize the stream low and high bands to avoid continuously switching between open and close stages.

Sample settings could include:

- Stream 1: low band = 150 m<sup>3</sup>/hr, high band = 300 m<sup>3</sup>/hr
- Stream 2: low band = 140 m<sup>3</sup>/hr, high band = 280 m<sup>3</sup>/hr
- Stream 3: low band = 150 m<sup>3</sup>/hr, high band = 300 m<sup>3</sup>/hr

These settings then set the ranges:

- One online stream has the range 150 to 300 m<sup>3</sup>/hr
- Two online streams have the range 290 to 580 m<sup>3</sup>/hr
- Three online streams have the range 440 to 880 m<sup>3</sup>/hr

**Algorithm 2** This algorithm uses the stream low and high bands but compares the station observed flow rate against the current operating range (that is, the summated low and high bands of the online streams).

If the observed station flow is **less** than the summated low range for the specified Deviation Time **and** two or more streams are open, Config600 closes the lowest priority open stream. If only one stream is online, Config600 takes no action.

If the observed station flow is **greater** than the summated high range for the specified Deviation Time and another stream is available for opening, Config600 opens the highest priority available stream. If no stream is available for opening, an alarm occurs but Config600 performs no switching actions.

**Algorithm 3** This algorithm uses the stream low and high bands but compares the station flow rate setpoint against the current operating range (that is, the summated low and high bands of the online streams).

If the station flow setpoint is **less** than the summated low range for the specified Deviation Time **and** two or more streams are open, Config600 closes the lowest priority open stream. If only one stream is online, Config600 performs no actions.

If the station flow setpoint is **greater** than the summated high range for the specified Deviation Time and another stream is available for opening, then Config600 opens the highest priority available stream. If no stream is available for opening, an alarm occurs but Config600 performs no switching actions.

**Algorithm 4** This algorithm is the same as Algorithm 3, but adds the ability to distribute the flow rate setpoint across the online streams.

Having determined the streams that should be open, Config600 uses the following formula for the distribution of the flow setpoint to each open (or opening) stream:

- **Station offset** is the station setpoint minus (sum of low bands of streams to be opened).
- **Station span** is the (sum of high bands of streams to be opened) minus (sum of low bands of streams to be opened).

For each open (or opening) stream:

- **Stream span** is stream high band minus low band.
- **Stream setpoint** is stream low band plus (station offset / station span) multiplied by stream span.

The following example uses the cited parameters, a setpoint of 350 m<sup>3</sup>/hr, and streams 1 and 2 are open;

- For stream 1, low band = 150 m<sup>3</sup>/hr and high band = 300 m<sup>3</sup>/hr.
- For stream 2, low band = 140 m<sup>3</sup>/hr and high band = 280 m<sup>3</sup>/hr.
- Station offset is  $350 - (150 + 140) = 60$ .
- Station span is  $(300 + 280) - (150 + 140) = 290$ .
- Stream 1 span is  $300 - 150 = 150$ .
- Stream 1 setpoint is  $150 + (60 / 290) * 150 = 181$  m<sup>3</sup>/hr.
- Stream 2 span is  $280 - 140 = 140$ .
- Stream 2 setpoint is  $140 + (60 / 290) * 140 = 169$  m<sup>3</sup>/hr.

Based on this, the station downloads a value of 181 m<sup>3</sup>/hr to the setpoint for stream 1 and 169 m<sup>3</sup>/hr to the setpoint for stream 2.

**Flow Switching Stages** You associate a station with a stream using the stream flow switching configuration table, which means that the stream shares a number with the station (displayed as Station No). This enables you to dynamically allocate a single stream to different loads.

Prior to performing stage handling, flow switching performs a set of calculations to determine:

- The number of streams open for each station.
- The number of streams still available for opening.
- The highest priority stream for opening (algorithm-dependent).
- The highest priority stream for closing (algorithm-dependent).
- The number of open streams.
- The number of streams still available for opening.

For each station, the flow switching stage assumes one of the following values, remaining in that stage until an event occurs.

<b>Display</b>	<b>Description</b>
IDLE	On issue of the Start-up command: If no streams are open and at least one stream is available, proceed to <b>Open First Stream</b> . If at least one stream is on line then proceed to <b>Monitor Flow</b> .
MONITOR FLOW	On issue of the Shutdown command, proceed to <b>Shutdown</b> . On issue of the ESD command, proceed to <b>Emergency Shutdown</b> . Invoke the configured switching algorithm (this may invoke a change of stage number).
OPEN 1ST STREAM	If the manual Open First Stream parameter is not set, issue Line Open command to the stream marked for opening. On issue of the Shutdown command, proceed to <b>Shutdown</b> . On issue of the ESD command, proceed to <b>Emergency Shutdown</b> . When the stream has opened, proceed to <b>Post Open Delay</b> .
OPEN STREAM	Issue Line Open command to the stream marked for opening. On issue of the Shutdown command, proceed to <b>Shutdown</b> stage. On issue of the ESD command, proceed to <b>Emergency Shutdown</b> . When the stream has opened, proceed to <b>Post Open Delay</b> .
CLOSE STREAM	Issue Line Close command and zero the flow rate setpoint for the stream marked for closing. On issue of the Shutdown command, proceed to <b>Shutdown</b> . On issue of the ESD command, proceed to <b>Emergency Shutdown</b> . When the stream has closed, proceed to <b>Post Close Delay</b> .

<b>Display</b>	<b>Description</b>
CLOSE LAST STREAM	If the manual close last stream parameter is not set then issue line close command and zero the flow rate setpoint for the stream marked for closing. On issue of the shutdown command, proceed to <b>Shutdown</b> . On issue of the ESD command, proceed to <b>Emergency Shutdown</b> . When the stream has closed, proceed to <b>Delay after Closing</b> .
POST OPEN DELAY	On issue of the Shutdown command, proceed to <b>Shutdown</b> . On issue of the ESD command, proceed to <b>Emergency Shutdown</b> . On expiration of the delay timer, proceed to <b>Monitor Flow</b> .
POST CLOSE DELAY	On issue of the shutdown command, proceed to <b>Shutdown</b> stage. On issue of the ESD command, proceed to <b>Emergency Shutdown</b> stage. On expiration of the delay timer, if all streams are now closed, proceed to <b>Idle</b> else proceed to <b>Monitor Flow</b> .
SHUTDOWN	On issue of the Startup command, proceed to <b>Monitor Flow</b> On issue of the ESD command, proceed to <b>Emergency Shutdown</b> . Issue Line Close command and zero the flow rate setpoint for the next stream marked for closing. When the marked stream closes: If there is only one more stream to close then proceed to <b>Close Stream</b> , else Repeat this stage until there is only one stream left to close.
EMERGENCY SHUTDOWN	At issue of the Startup command, proceed to <b>Monitor Flow</b> . Issue Line Close command and zero the flow rate setpoint for all the open streams. When all streams are closed, proceed to <b>Idle</b> .

#### C.4.4 Alarms

Flow switching does not raise any alarms.

### C.5 Batch Stack

Batching allows you to configure and edit a stack of 16 products, called a “batch stack.” Each batch stack element is called a “batch slot” and each batch slot holds the relevant information for batching (product number, batch ID, customer number, batch type, meter type, quantities, and flowrates).

A batch slot is considered empty or undefined if the product number is not set (that is, the product number is zero).

Each time a batch starts, the system copies information from data in stack position #1 and uses it in the batching logic. The first batch slot is then deleted and the rest of the slots advance one position. This is “advancing the stack.” As a result, after the batch starts, the first slot element contains the data for the next batch.

When the system advances the stack, it ignores empty or undefined batch slots and uses the first defined slot it encounters.

If the batch is continuous, when the batch ends the system automatically advances the batch stack and copies the next element so that the data can be used for the next batch. Advancing a continuous volume load or mass load batch is done only if the required quantity for the next product is non-zero. If the required quantity for the next batch stack slot is zero, the batch stops and an alarm occurs to mark that the batch stopped.

A volume or mass load batch **cannot** start if there is no required quantity, and the system will reject the start command. For a batch stack of only one product, regardless of the batching type, advancing is not performed. The defined slot is not deleted when starting or restarting a batch and the data defined in that slot is used for all batches. However, the data is copied every time a start or restart is performed. This allows you to edit the slot information.

If you select batching when creating a configuration file, the objects needed for the batch stack are added by default, but they are not initialised. Batching will not work until the batch stack slots are configured, and all batch commands will be rejected.

You can configure the batch stack slots four different ways: through the Batch Stack screen in the PCSetup Editor, by directly editing the configuration file through System Editor, at run-time from the front panel of the S600+, and at run-time from the Webserver.

### C.5.1 Configuring the Batch Stack Through the PCSetup Editor

The Batch Stack screen in the PCSetup Editor allows you to configure batch slots. You can edit the parameters of a batch slot, delete a batch slot entirely, or copy the parameters of a batch slot to another slot in the stack.

To configure the Batch Stack through the PCSetup Editor:

1. Select **Batch Stack** from the hierarchy menu. The Batch Stack screen displays.

---

**Note:** The screen below shows available fields for all options in the Actions pane.

---

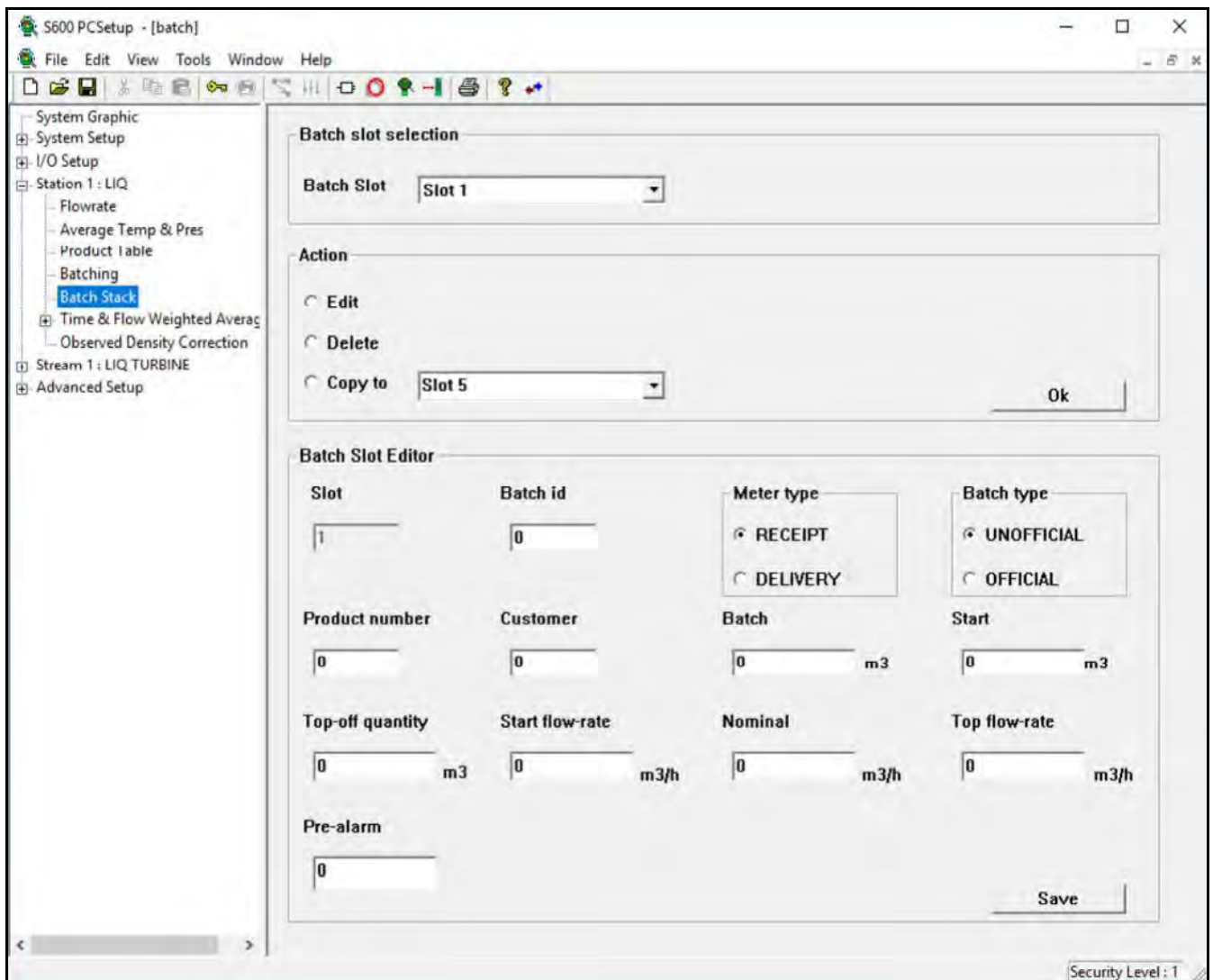

Figure C-24. Batch Stack

2. Click ▼ to select the batch slot you want to change. The Action pane displays.
3. To delete the selected batch slot, select **Delete** in the Action pane and click **Ok** to delete the selected batch slot. The system displays a confirmation screen. Click **Yes** to delete the batch slot.
4. To copy parameters from the selected batch slot to another, select **Copy to** in the Action pane, click ▼ to select the batch slot to which the parameters are copied, and click **Ok**. The system displays a confirmation screen. Click **Yes** to copy the batch slot.
5. To modify parameters for the selected batch, select **Edit**. The Batch Slot Editor displays.

6. Complete the following fields:

Field	Description
<b>Slot</b>	This <b>read-only</b> field displays the number of the currently selected batch slot.
<b>Batch id</b>	Sets the Batch ID for the selected batch slot. Valid values are 0 through 65535.
<b>Meter type</b>	Determines whether this is a delivery or a receipt. Possible values are: <b>RECEIPT</b> The batch is a receipt. <b>DELIVERY</b> The batch is a delivery.
<b>Batch type</b>	Determines whether this is an official or unofficial batch. Possible values are: <b>UNOFFICIAL</b> The BATCH NUMBER is 0. <b>OFFICIAL</b> The BATCH NUMBER increases by 1.
<b>Product number</b>	Sets the product number used by the selected batch slot. Valid values are 1 through 16.
<b>Customer</b>	Sets the customer number for the selected batch slot. Valid values are 0 through 65535.
<b>Batch</b>	Sets the total quantity of the batch.
<b>Start</b>	Sets the start quantity of the batch. The system uses the flow rate set in the <b>Start flow-rate</b> field at the beginning of the batch until this quantity is met.
<b>Top-off quantity</b>	Sets the top-off quantity of the batch. The system uses the flow rate set in the <b>Top flow-rate</b> field for the remainder of the batch when this quantity is remaining.
<b>Start flow-rate</b>	Sets the flow rate the system uses at the start of the batch until the quantity set in the <b>Start</b> field is met.
<b>Nominal</b>	Sets the nominal flow rate for the selected batch slot. The nominal flow rate is used after Start flow rate and before the Top flow-rate. Quantities and Flowrates are always positive values.
<b>Top flow-rate</b>	Sets the flow rate the system uses at the end of the batch when the quantity set in the <b>Top-off quantity</b> field is remaining. Quantities and Flowrates are always positive values.
<b>Pre-alarm</b>	Sets a percentage of the entire batch amount that, when reached, raises an alarm. Valid values are 0% to 100%.

7. Click **Save** to apply your changes.

### C.5.2 Configuring the Batch Stack with the System Editor

When you use the System Editor to configure the batch stack, it is recommended that you **first** define **all** the data – batch ID, product number, customer number, quantities, flowrates, and pre-alarm percentage – for **each** slot.



1. Select **Start > Programs > Config600 3.3 > System Editor**.
2. Select **Station X > KPINTARR**.
3. Double-click **STN0X NEXT PRODUCT** and edit Fields 1 through 16 for the corresponding batch stack slots. This array holds the product type of each stack slot. Valid values are 0 through 16. Values 1 through 16 define correct product types. If using product number 0, the slot is considered as undefined.
4. Select **OK** to save changes.
5. Double-click **STN0X NEXT CUST** and edit Fields 1 through 16 for the corresponding batch stack slots. This array holds the Customer number for each stack slot. Valid values are 0 through 65535.
6. Select **OK** to save changes.
7. Double click **STN0X NEXT BATCH ID** and edit Fields 1 through 16 for the corresponding batch stack slots. This array holds the Batch ID for each stack slot. Valid values are 0 through 65535.
8. Select **OK** to save changes.
9. Double-click **STN0X MTR TYPE** and edit Fields 1 through 16 for the corresponding batch stack slots. This array holds the Meter Type for each stack slot. Valid values are 0 and 1.
10. Select **OK** to save changes.
11. Double-click **STN0X BCH TYPE** and edit Fields 1 through 16 for the corresponding batch stack slots. This array holds the Batch Type for each stack slot. Valid values are 0 and 1.
12. Select **OK** to save changes.
13. Select **Station X > KPREALARR**.
14. Edit the fields of arrays **STN0X START QTY**, **STN0X REQD QTY**, **STN0X TOP QTY**, **STN0X F/R START**, **STN0X F/R NOMINAL**, **STN0X F/R TOPOFF**, and **STN0X PRE ALARM** to edit the properties corresponding to (in order): Start quantity, Required quantity, Top-off quantity, Start flowrate, Nominal flowrate, Top-off flowrate, Pre-alarm percentage.

Valid values for **STN0X PRE ALARM** are between 0.0 and 100.0 while values for all of the other arrays should be positive.

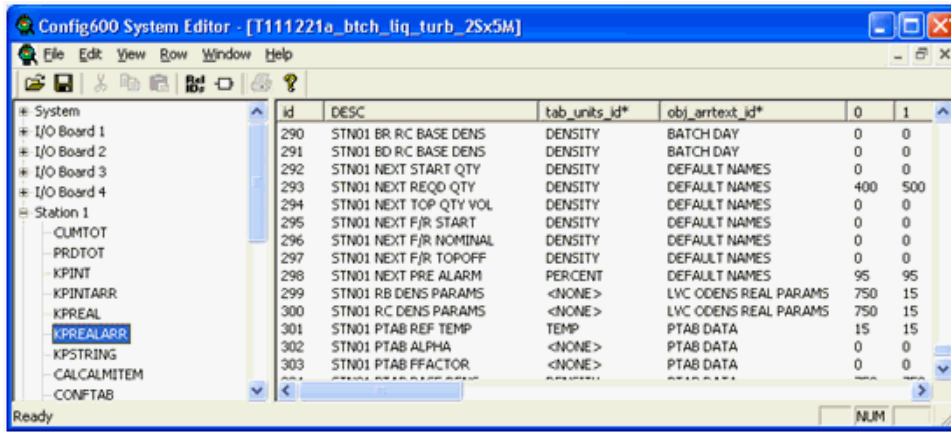

Figure C-25. Config600 System Editor (1)

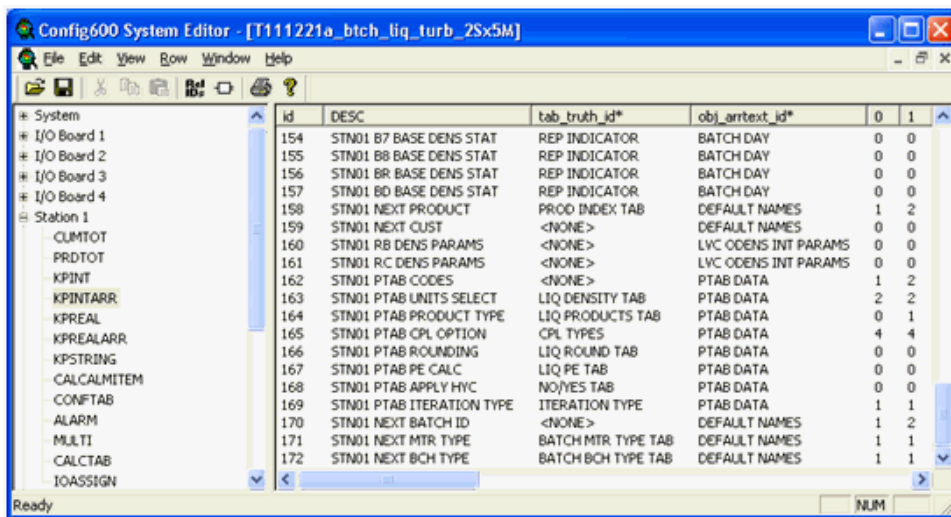

Figure C-26. Config600 System Editor (2)

### C.5.3 Configuring the Batch Stack through the Front Panel Display

1. Navigate to **OPERATOR > STATION X > BCH STACK**.
2. The display shows all the batch stack slots in numerical order. Press the Left and Right keys to navigate through the slots.

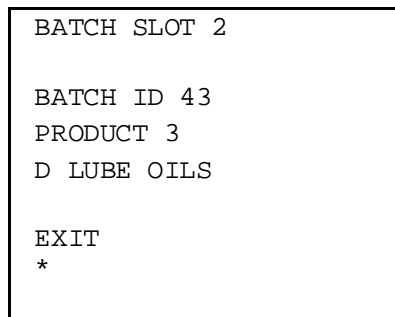

Figure C-27. Batch Slots

3. Press **CHNG** to edit the selected slot.

- |                    |
|--------------------|
| 1. MOVE TO TOP     |
| 2. MOVE TO SLOT    |
| 3. MOVE DOWN       |
| 4. INS BCH         |
| 5. INS BCH TO SLOT |
| 6. COPY TO SLOT    |
| 7. EDIT SLOT       |
| 8. DELETE SLOT     |

Figure C-28. Slot Editing Options

4. Press the number key that corresponds to the action you want to perform.

### C.5.4 Slot Edit Commands (Front Panel Display)

The slot edit commands you can access through the Front Panel Displays have the following functions:

- **MOVE TO TOP / MOVE DOWN**  
These commands move the stack slot up and down by one slot, respectively. If you are editing the first slot, the system disables the MOVE TO TOP command; if you are editing the last slot, the system disables the MOVE DOWN command.
- **MOVE TO SLOT**  
Select MOVE TO SLOT to access a display that enables you to set the destination slot. When moving a slot, if the destination slot number is **smaller** than the source slot number, the system moves the source up the stack, to the destination slot. All slots from the destination slot to the source slot are moved down one position and the source slot is copied over the destination slot. Similarly, if the destination slot number is **greater** than source slot number, the system moves the source down in the stack, to the destination slot. All slots from the source to the destination are moved up one position and the source slot is copied over the destination slot. For example, if you have a batch stack slot order of 1, 2, 3, 4, 5, 6, and you move slot 6 to slot 3, the resulting batch stack slot order would be 1, 2, 6, 3, 4, 5.
- **INS BCH / INS BCH TO SLOT**  
The system disables these commands if the batch stack is full. When you select INS BCH TO SLOT the system displays a screen that changes the slot in which the data is inserted:

ENTER SLOT NUMBER:
VALUE:
14
ENTER - NEXT
CLEAR - CANCEL

Figure C-29. Insert Batch Command

Following this screen or selecting INS BCH TO SLOT you are taken to a succession of screens where you can change the data (batch ID, meter type, batch type, product number, customer number, batch quantity, start quantity, top-off quantity, start flowrate, nominal flowrate, top-off flowrate, and pre-alarm percentage) for the new slot. Press ENTER to move to the next screen; press LEFT to return to the previous screen.

```

BATCH ID

VALUE:
    12345      *

ENTER - NEXT
CLEAR - CANCEL
    
```

```

METER TYPE

VALUE:
RECEIPT      *

ENTER - NEXT
CLEAR - CANCEL
    
```

```

BATCH TYPE

VALUE:
OFFICIAL     *

ENTER - NEXT
CLEAR - CANCEL
    
```

```

PRODUCT NUMBER

VALUE:
    1          *

ENTER - NEXT
CLEAR - CANCEL
    
```

```

CUSTOMER NUMBER

VALUE:
    12345     *

ENTER - NEXT
CLEAR - CANCEL
    
```

```

BATCH QUANTITY

VALUE(m3):
           0.0000 *

ENTER - NEXT
CLEAR - CANCEL
    
```

```

START QUANTITY

VALUE(m3):
           0.0000 *

ENTER - NEXT
CLEAR - CANCEL
    
```

```

TOP-OFF QUANTITY

VALUE(m3):
           0.0000 *

ENTER - NEXT
CLEAR - CANCEL
    
```

```

START FLOWRATE

VALUE(m3/h):
           0.0000 *

ENTER - NEXT
CLEAR - CANCEL
    
```

```

NOMINAL FLOWRATE

VALUE(m3/h):
           0.0000 *

ENTER - NEXT
CLEAR - CANCEL
    
```

```

TOP-OFF FLOWRATE

VALUE(m3/h):
           0.0000 *

ENTER - NEXT
CLEAR - CANCEL
    
```

```

PRE-ALARM PERCENTAGE

VALUE(%):
           0.0000 *

ENTER - NEXT
CLEAR - CANCEL
    
```

Each of these displays shows the current value of the field. Press CHNG to access a screen showing the current value and the range limits, and where you can insert a new value using the numerical keys. The LEFT key works as backspace, deleting one character at a time.

Each data field has its own specific entry limits: Batch ID and Customer number range is 0 to 65535; Product number and batch slot range is 1 to 16; Quantities and Flowrates are always positive values, Pre-alarm percentage range is 0 to 100%. If you enter a value which is out of the valid range for the respective field, the system displays an error message and returns you to the screen showing the current value of the field.

Press ENTER to accept the new data; press CLEAR to abort a data change. After you press ENTER or CLEAR, the system returns you to the screen, showing the field you edited.

```

CURRENT VALUE:
                0.00
%
LIMITS OF ENTRY:
100.000
0.000
ENTER NEW VALUE:
54.23
    
```

*Figure C-30. Entering Data*

```

CURRENT VALUE:
                0.00
%
LIMITS OF ENTRY:
100.000
0.000
ENTER NEW VALUE:
ABORTED
    
```

*Figure C-31. Pressing CLEAR*

```

CURRENT VALUE:
                0.00
%
LIMITS OF ENTRY:
100.000
0.000
OUT OF RANGE
    
```

*Figure C-32. Input out of Range*

Press ENTER in the last screen (Pre-alarm percentage) to accept the data entered in the previous screens.

If you have selected **INS BCH**, the system accepts data to the next free slot in the batch stack. That is, if the next free slot is slot number 14, after you complete all the steps to insert a batch slot and press ENTER, the system saves data in slot number 14.

If you select **INS BCH TO SLOT** and the slot in which you want to insert data is not empty, the system moves all the slots following that slot towards the first empty slot by one position, filling up the first empty slot in the stack, in order to prevent the loss of non-empty batch stack slots. For example, if the batch stack slots 1 through 10 are defined and you want to insert a batch slot to slot number 5, the system moves slots 5, 6, 7, 8, 9 and 10 down one position (to positions 6, 7, 8, 9, 10 and 11) and places the data entered in the **INS BCH TO SLOT** procedure in slot number 5.

Pressing **CLEAR** at any time in the screen succession displays a confirmation screen, verifying that you want to abort the insert for the new batch slot. Aborting takes you back to the batch stack slot screens.

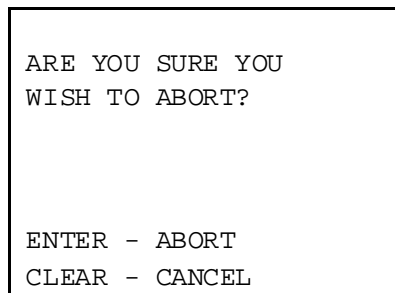

*Figure C-33. Abort Confirmation Screen*

If a batch has started and it advances while you are editing the data in the screen sequence, when you press ENTER in the last screen the system displays an error message showing that the batch stack has advanced. The system then discards all the changes.

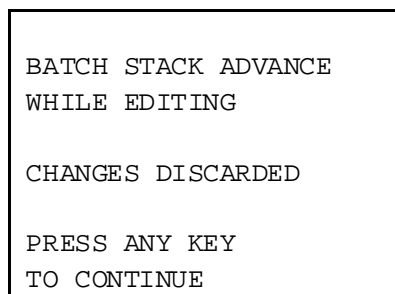

*Figure C-34. Changes Discarded Message*

- **COPY TO SLOT**

When you select this option, the system displays a screen where you can enter the destination slot:

```
COPY SLOT 4

RANGE 1..16
      5

ENTER - ACCEPT
CLEAR - CANCEL
```

*Figure C-35. Copy to Slot*

If the destination slot is not empty, the system displays a confirmation screen and gives you the option to overwrite the destination slot. If you choose not to overwrite the destination slot, the system makes no changes.

```
COPY TO SLOT 5

SLOT IS NOT EMPTY
OVERWRITE DATA?

ENTER - ACCEPT
CLEAR - CANCEL
```

*Figure C-36. Confirmation Screen*

- **EDIT SLOT**

When you select this option, the system displays a screen sequence that enables you to change the data of the batch slot. The succession of displays and functionality is identical to the one for the INS BCH command. Please see the section describing the INS BCH command for details on functionality. When you press ENTER at the last screen of the sequence (Pre-alarm percentage), the system stores the new data in the selected batch slot **without** displaying a confirmation screen.

If a batch has started and it advances while you are editing the data in the screen sequence, when you press ENTER in the last screen, the system displays an error message indicating that the batch stack has advanced. The system then discards all the changes.

```
BATCH STACK ADVANCED
WHILE EDITING

CHANGES DISCARDED

PRESS ANY KEY
TO CONTINUE
```

*Figure C-37. Changes Discarded*

- **DELETE SLOT**

When you select this option the system displays a screen prompting you to confirm the deletion of the selected slot:

```
DELETE SLOT 5

ENTER - ACCEPT
CLEAR - CANCEL
```

*Figure C-38. Delete Confirmation*

When deleting a slot, if there are valid slots in the batch stack after the deleted slot, the system advances the remaining valid batch slots one position in the batch stack. For example, if the first ten slots are configured and you delete slot number 4, the system moves slots 5 to 10 up one position so that slot 5 moves to slot 4, slot 6 moves to slot 5, and so on.

If there is a continuous batch running (volume load or mass load) and there is only one batch slot defined, the system disables the DELETE command.

### **C.5.5 Configuring the Batch Stack from the Webserver**

1. Navigate to **OPERATOR > STATION X > BCH STACK**.
2. Navigate to the batch slot you wish to edit.





Figure C-39. Batch Slots

3. Select **EDIT**; the system displays a page showing the edit options for the selected slot:

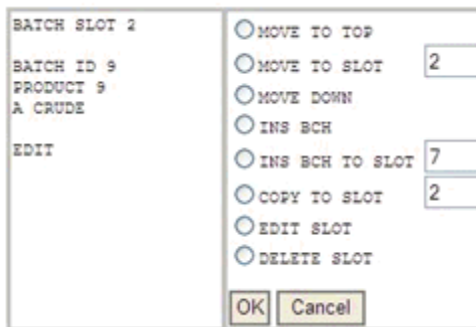

Figure C-40. Slot Editing Options

4. Press the numeric keys corresponding to the command you wish to perform.

### C.5.6 Slot Edit Commands (Webserver)

The slot edit commands you can access through the Webserver have the following functions:

- **MOVE TO TOP / MOVE DOWN / MOVE TO SLOT**  
Select any of these options and click OK to move the slot is moved

to the top of the batch stack, to move the slot down by one position, or to move the slot to a specific location (as defined in the MOVE TO SLOT field).

Whenever you move a slot, the system does not lose or overwrite data. If the number of the destination slot is **smaller** than the number of the source slot, the source moves up in the stack, to the destination slot. All slots from the destination slot to the source slot move down one position and the system copies the source slot over the destination slot. If the number of the destination slot is **greater** than the number of the source slot, the system moves the source down in the stack, to the destination slot. All slots from the source to the destination move up one position and the system copies the source slot over the destination slot. For example, you have a batch stack slot order of 1, 2, 3, 4, 5, 6, and you move slot 6 to slot 3, the resulting batch stack slot order would be 1, 2, 6, 3, 4, 5.

The system validates the text field which contains the destination slot. If the value is not the correct range (1 to 16), the system displays an error message below the OK and CANCEL buttons and resets the text field to the default value, which is the slot number of the selected slot.

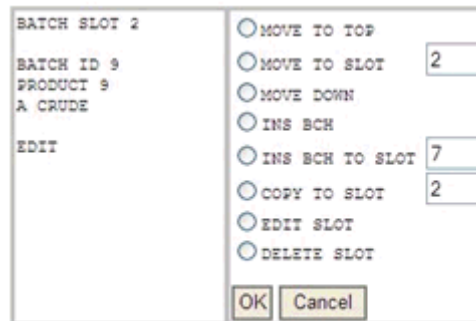

Error - data out of range

If you select the first slot in the batch stack, the system disables the MOVE TO TOP command. If you select the last slot in the batch stack, the system disables the MOVE DOWN command.

- **INS BCH / INS BCH TO SLOT**

When you select this option, you enter the slot number where the new slot will be inserted in the text field next to the command name.

After you click **OK**, the system displays another pages with all the data that needs to be edited for a new slot. All the text fields (except the SLOT NUMBER) are pre-loaded with default values.

The system disables these two commands if the batch stack is full (that is, all 16 slots are defined).

SLOT NUMBER 7	BATCH ID 0	METER TYPE <input checked="" type="radio"/> RECEIPT <input type="radio"/> DELIVERY	BATCH TYPE <input checked="" type="radio"/> UNOFFICIAL <input type="radio"/> OFFICIAL
PRODUCT NUMBER 0	CUSTOMER NUMBER 0	BATCH QUANTITY 0.0000 m <sup>3</sup>	START QUANTITY 0.0000 m <sup>3</sup>
TOP-OFF QUANTITY 0.0000 m <sup>3</sup>	START FLOW-RATE 0.0000 m <sup>3</sup> /h	NOMINAL FLOW-RATE 0.0000 m <sup>3</sup> /h	TOP-OFF FLOW RATE 0.0000 m <sup>3</sup> /h
PRE-ALARM PERCENTAGE 0.000 %			
<input type="button" value="OK"/> <input type="button" value="Cancel"/>			

When you select **INS BCH**, the system disables the **SLOT NUMBER** text field and sets it to the number of the next free slot in the batch stack.

When you select **INS BCH TO SLOT**, the system displays the value entered on the previous page in the **SLOT NUMBER** text field and enables it for editing.

The system performs range checks on all data, according to each field's specific entry limits: Batch ID and Customer number range is 0 to 65535; Product number and batch slot range is 1 to 16; Quantities and Flowrates are always positive values; and Pre-alarm percentage range is 0 to 100%.

SLOT NUMBER 1	BATCH ID 0	METER TYPE <input type="radio"/> RECEIPT <input checked="" type="radio"/> DELIVERY	BATCH TYPE <input type="radio"/> UNOFFICIAL <input checked="" type="radio"/> OFFICIAL
PRODUCT NUMBER 1	CUSTOMER NUMBER 0	BATCH QUANTITY 400.0000 m3	START QUANTITY 0.0000 m3
TOP-OFF QUANTITY 0.0000 m3	START FLOW-RATE 0.0000 m3/h	NOMINAL FLOW-RATE 0.0000 m3/h	TOP-OFF FLOW RATE 0.0000 m3/h
PRE-ALARM PERCENTAGE 95.000 %			
<input type="button" value="OK"/> <input type="button" value="Cancel"/>			

Error - data out of range

When you press **OK**, if at least one of the fields is out of range, the system displays an error message (“Error – data out of range”) on the bottom of the screen. Additionally, the system highlights those fields in orange and resets them to 0.0.

If the batch stack advances while you are inserting a new batch, the system displays an error indicating that the batch stack has advanced. The system then discards all changes.

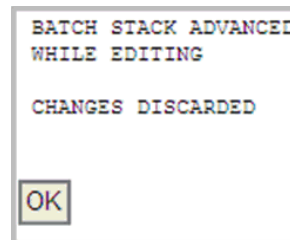

▪ **COPY TO SLOT**

When you select this option and click **OK**, the system copies the selected slot to the destination slot entered in the text field next to the COPY TO SLOT text.

If the slot is invalid, the system displays an error message on the bottom of the page and resets the value in the text field set to the default value, which is the slot number of the selected slot.

If the destination slot is not an empty slot, the system then prompts you to overwrite the data in the destination slot.

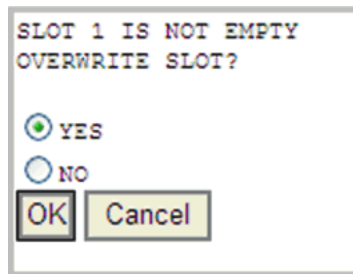

- **EDIT SLOT**

When you select this option and click OK, the system displays a page where you can edit all the data for a batch stack slot. Note that the SLOT NUMBER of the edited slot is **not** available for editing and is disabled.

The functionality for this option is identical to the **INS BCH** options; refer to that description for further details of use.

The system pre-loads all the text fields with the current data of the selected batch stack slot so there is no chance of accidentally changing important data.

When you click **OK** the system saves new data to the selected batch stack slot.

- **DELETE SLOT**

When you select this option and click OK, the system deletes the selected batch stack slot and moves the rest of the batch stack slots below the deleted slots up one position. The system automatically inserts a new empty slot in the last position of the batch stack as slot number 16. No confirmation screen follows the selection of the DELETE command.

If there is a continuous volume load or mass load batch running and only one batch stack slot is defined, the system disables the DELETE command.

## C.6 Basic Batching Setup

---

If basic batching is required (i.e. single product with the start / stop commands being issued manually (i.e. no enterable required batch quantity and no recalculation) then the following steps should be followed.

1. Create a batching application containing “station batching with product table” and “stream batching with product table basic”.
2. Configure Product 1 in the station product table with the correct information.
3. Configure the station batching as VOL LOAD or MASS LOAD.
4. Configure Slot 1 in the batch stack with a large batch quantity (9,999,999,999) and product id for Product 1.
5. Configure the stream batching as supervised.
6. Update the displays so that only the station batch command, station batch stage and batch number are visible.

- 7.** Remove all station product displays (if required the data for product 1 can remain).
- 8.** Remove all the station batch current displays (Stack, Interface, Control, Base Dens, BSW, Recalc and Results).
- 9.** Remove all the station batch recall displays (Ticket, Base Dens, BSW, Recalc, Results).
- 10.** Remove all the stream batch current displays (Mtr Temp, Mtr Press, Avg KF and Results).
- 11.** Remove all the stream batch recall displays (Mtr Temp, Mtr Press, Avg KF and Results).
- 12.** To start a batch the operator should use the Batch Define command. The batch totals will then start incrementing once flow is received (note the batch status will remain at Batch Defined for the duration of the batch).
- 13.** The batch can be stopped at any time by the operator entering the Batch Terminate command.

## Appendix D – Field Calibration

### In This Chapter

D.1	Analogue Input Calibration.....	D-1
D.1.1	Calibration Control Requirements.....	D-2
D.1.2	Linear Two-point ADC Device Calibration.....	D-3
D.1.3	Non-linear 3-point Curve-fit ADC Device Calibration.....	D-6
D.1.4	Non-linear 3-point Curve Calibration Control Mechanism	D-7
D.1.5	Offset PRT Device Calibration .....	D-8
D.1.6	Linear 2-point Device PRT Calibration.....	D-8
D.1.7	Non-linear 3-point Curve-Fit PRT Device Calibration.....	D-9
D.2	Analogue Output Calibration.....	D-10
D.2.1	Calibration Control Requirements.....	D-10
D.2.2	DAC Device Calibration .....	D-11

This appendix describes the hardware calibration you perform after production to determine the relationship between analogue converter counts and current.

### D.1 Analogue Input Calibration

Do not confuse process calibration with the production hardware calibration you perform on all IO modules subsequent to manufacturing. You perform hardware calibration after production to determine the relationship between analogue converter counts and current in mA for Analog to Digital Converters (ADCs) or converter counts and resistance in the case of Platinum Resistance Thermometers (PRTs). Hardware calibration process essentially “fixes” each individual input channel the way in which the S600+ measures the current or resistance.

Process calibration **does not** alter this counts-to-measure relationship.

In the case of ADCs, there are two methods of calibration available:

1. The first method defines the relationship between the perceived input current (as measured by the analogue converter using the hardware calibration data) and plant transducer engineering units. Even after a process calibration, the analogue device may not produce a current reading corresponding to the true circuit current. However, the device should perform a conversion to provide an accurate representation of the engineering units associated with the transducer applied to the analogue input.
2. The second method (current calibration) calibrates the input current applied at the transducer and the perceived raw current (as measured by the analogue converter using the hardware calibration data), this uses mA for both.

In the case of the PRTs, you can use the process calibration to modify the conversion or to bypass the temperature lookup tables which the S600+ normally employs.

## D.1.1 Calibration Control Requirements

The firmware automatically controls the calibration mechanism internally to ensure that the system integrity is not impaired during the calibration process. The firmware applies the following three conditions during a calibration:

1. The operational status of any PID control loops during calibration. Any loop employing a field input device which is under calibration should be automatically disabled. Thus if the control loop is in auto mode, the control output remains at the last generated state until the field device returns to normal operation. This safeguard does not extend to locking the output if the control loop is in manual mode or switching to manual mode during calibration. Manual mode overrides the loop disable.
2. You cannot perform part of a calibration and effectively impair the integrity of field input data. The calibration control task uses a configurable timer to monitor all calibration operations. If you perform part of a calibration but do not complete the process prior to timeout, the control task reverts all calibration data to its initial state prior to the start of the calibration operation. The calibration terminates and an error displays. The default timeout setting for an **online** calibration is 15 minutes; the default timeout setting for a **manual** calibration is 30 seconds. These times are configurable. For more information contact Technical Support.
3. For an **online** calibration, you are **not** required to manually change the mode of a field input prior to initiating the calibration sequence. The calibration control mechanism ensures that the mode switches to a known safe state prior to continuing. For a **manual** calibration the mode is unchanged. The following table presents the online calibration mode changes for the ADCs and PRTs.

Pre-calibration Mode	Calibration Mode
Measured	LastGood
Keypad	Keypad
Average	Average
LastGood	LastGood
Keypad-F	Keypad
Average-F	Average
LastGood-F	LastGood

At the end of an online calibration (or if the calibration was aborted), the mode of the ADC or PRT automatically reverts back to the pre-calibration mode. For manual calibrations, the mode remains unchanged.



**Notes:**

- You can change a device’s mode during calibration. The calibration package updates calibration specific object data, (such as Gradient or Offset) only when a coherent data set is available.
- The **online calibration mode** reads values directly from the ADC. The **manual calibration mode**, uses default values for a 4-20 mA or 1.5 Vdc ADC (hi\_current = 20, mid\_current = 12 and lo\_current = 4) and for a 0-20mA or 0-5 Vdc ADC (hi\_current = 20, mid\_current = 10 and lo\_current = 0).

## D.1.2 Linear Two-point ADC Device Calibration

This method enables you to calibrate an ADC device across a linear range by entering high and low range process setpoints as well as an offset adjustment factor. You can then define the setpoints and offset making the calibration device/process dependent.

**Operator Interface** To calibrate the linear two-point ADC device:

1. Navigate to an analogue input channel requiring calibration.
2. Move to the low range calibration display page. This page has an entry for the low range setpoint, an indication of the associated current reading at this setpoint, and the current measured value associated with this device.

```

ADC Channel 1
Meter Temperature
CALIB (LO/CUR/MEAS)
xxxx.xx      DegF *
xxxx.xx      mA
xxxx.xx      DegF
P12.3 <of 10>
```

3. Once you stabilise the plant device to the low range process setting, enter a low range setpoint. When you press Return the flow computer takes and stores a current reading for the selected channel. The display page then indicates the low range setpoint and the associated low range current reading. For current calibration, the low range setpoint and the associated low range raw current value display.

```

ADC Channel 1
Meter Temperature
CALIB (LO/CUR/MEAS)
 23.00      DegF *
 10.87      mA
 23.54      DegF
P12.3 <of 10>
```

4. Repeat this process for the high range setpoint.

```

ADC Channel 1
Meter Temperature
CALIB (HI/CUR/MEAS)
      89.00      DegF *
      18.27      mA
      89.94      DegF
P12.4 <of 10>
    
```

5. Include an additional device offset adjustment if required. You define this by setting the plant device to its zero position and then navigating to the offset display for the relevant analogue input. The system then prompts you to accept a change request which initiates the acquisition of an offset current reading. Following are examples of the display before and after the acquisition of the offset calibration.

```

ADC Channel 1
Meter Temperature
CALIB (OFF/CUR/MEAS)
      0.00      DegF
      4.63      mA
      1.07      DegF
P12.5 <of 10>
    
```

```

ADC Channel 1
Meter Temperature
CALIB (OFF/CUR/MEAS)
      1.07      DegF
      4.63      mA
      0.00      DegF
P12.5 <of 10>
    
```

---

**Notes:**

- You can perform the low- and high-range calibrations in any order; there is no need to perform the low range calibration prior to the high range. The only requirement is that you complete **both** points within the calibration timeout period.
  - The calibration is deemed to have initiated when the first setpoint is entered. At this point the device mode is handled and any associated control loops are disabled.
- 

**Analogue Input Object (ADC)**

The calibration process uses the following fields:

ADC Object Field	Description	Data Type
LastGood field	Holds the last good value read from the analogue input.	[double]
LOrange field	The lowest value of the inputs total range to use in the calibration.	[double]
LOcurrent field	The measured current at the LOrange point.	[double]

ADC Object Field	Description	Data Type
Hlrange field	The highest value of the inputs total range to be used in the calibration.	[double]
Hlcurrent field	The measured current at the Hlrange point.	[double]
Gradient field	The gradient of the line between the LO and Hi range setpoints.	[double]
Off set field	The actual offset value used by the ADC, updated after a successful calibration.	[double]
Off set adjustment field	The offset entered during the calibration.	[double]
Calibration control field	Keeps track of the calibration status.	[char]

Where:

$$Gradient = \frac{HIScale - LOScale}{HICurrent - LOCurrent}$$

$$Offset = LOScale - (LOCurrent \times Gradient)$$

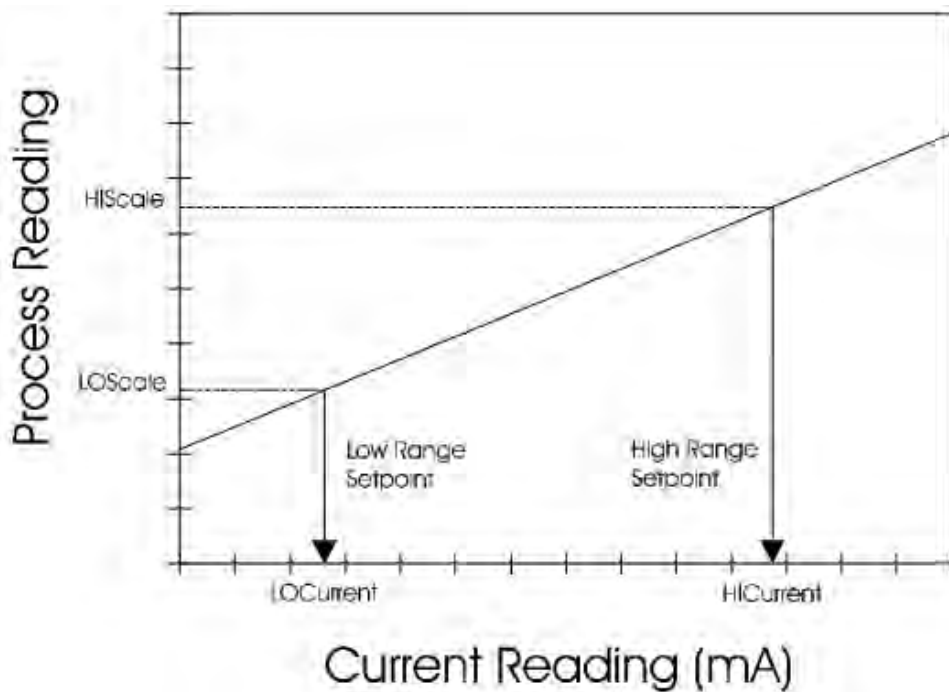

The calibration control field is used to perform controlled data readings from the analogue input channels at the IO board.

Then each analogue input current reading to plant value conversion is performed using:

$$Value = (Current \times Gradient) + Offset - Offset_{Adjust}$$

**Two-Point Control Mechanism**

The background control task auto-configures regardless of the IO configuration of a particular system. This task monitors each of the ADC object’s calibration control fields. The task remains idle until a control field is set indicating a calibration request has been made.

The calibration control field of each of the system’s ADC input objects identifies what type of modification has been requested. The displays task is responsible for marking the calibration control field when:

- You change the LOrange field.
- You change the Hlrange field.

- You perform an offset adjustment data capture.

When you modify the calibration control field the control task:

- Captures and places the current reading into the relevant data field. The previous settings are also logged internally.
- Initiates a calibration timer that monitors the operator.
- Continues the timer until you set the second of the two points.

---

**Note:** If the timer completes before you set the second point, the device reverts to its original (logged) settings and the calibration cycle aborts with an error (and associated alarm).

---

- Updates the relevant gradient, offset, and offset adjustment fields each time you perform a complete calibration cycle. The internally held previous settings will be discarded at this point.

When you make changes, an audit trail print initiates to indicate that a device calibration change has been performed. This trail indicates:

- The operator making the change.
- The change made.
- The old setting for this field.
- The new setting for this data field.

This printout uses a system event generation mechanism and as such has the same data attributes as any other system event. Additionally, the system stores the event data in the event record buffer (as is the case with all events generated by the flow computer). For example:

27/10/1998 13:48:58 S600+ USER: super-2	LOGGED IN LEVEL: 3
27/10/1998 13:50:03 S600+ Meter Temp MODE	LASTGOOD
27/10/1998 13:50:03 S600+ Meter Temp CALIB	LO SETPT CHANGED FROM 0.0 TO 23.0
27/10/1998 13:54:17 S600+ Meter Temp CALIB	LO CURR CHANGED FROM 0.0 TO 10.87
27/10/1998 13:54:17 S600+ Meter Temp CALIB	HI SETPT CHANGED FROM 100.0 TO 89.0
27/10/1998 13:54:17 S600+ Meter Temp CALIB	HI CURR CHANGED FROM 20.0 TO 18.27
27/10/1998 13:56:55 S600+ Meter Temp OFFSET	CHANGED FROM 0.0 TO 1.07
27/10/1998 13:56:59 S600+ Meter Temp CALIB	CYCLE COMPLETED
27/10/1998 13:50:03 S600+ Meter Temp MODE	MEASURED
27/10/1998 14:02:00 S600+ USER: super-2	LOGGED OUT

### D.1.3 Non-linear Three-point Curve-fit ADC Device Calibration

This method enables you to calibrate an ADC device across a non-linear range by entering high, mid, and low range process setpoints. The selection of these setpoints is user definable and thus device/process dependent.

---

**Note:** The **three-point calibration** process is **not applicable** to **ADC11/12**.

---

**Operator Interface** You perform this calibration in exactly the same manner as the linear two-point calibration with the exception that there is one additional display to accommodate the mid range calibration setpoint. Again, the order in which you define the three setpoints is irrelevant.

**Analogue Input Object (ADC)** The calibration process uses the following fields:

ADC Object Field	Description	Data Type
LastGood field	Holds the last good value read from the analogue input.	[double]
LOrange field	The lowest value of the inputs total range to use in the calibration.	[double]
LOcurrent field	The measured current at the LOrange point.	[double]
MIDrange field	The mid range value of the inputs total range to use in the calibration.	[double]
MIDcurrent field	The measured current at the MIDrange point.	[double]
Hlrange field	The highest value of the inputs total range to be used in the calibration.	[double]
Hlcurrent field	The measured current at the Hlrange point.	[double]
CurveCoeff_1 field	Calculated coefficient 1 value for use in the curve fit equation.	[double]
CurveCoeff_2 field	Calculated coefficient 2 value for use in the curve fit equation.	[double]
CurveCoeff_3 field	Calculated coefficient 3 value for use in the curve fit equation.	[double]
Calibration control field	Keeps track of the calibration status.	[char]

Then each analogue input current reading to plant value conversion is performed using the second order curve equation:

$$Value = (Coef1 \times Current^2) + (Coef2 \times Current) + Coef3 - Offset_{Adjust}$$

## D.1.4 Non-linear Three-point Curve Calibration Control Mechanism

The displays task marks the calibration control field when:

- You change the LOrange field.
- You change the MIDrange field.
- You change the Hlrange field.
- You perform an offset adjustment data capture.

When you modify the calibration control field of an ADC / PRT input the control task:

- Captures and places the current reading into the relevant data field and internally logs the previous settings.
- Initiates a calibration timer that monitors the operator.
- Continues the timer until you set the last of the three points.

---

**Note:** If the timer completes before you set the third point, the device reverts to its original (logged) settings and the calibration cycle aborts with an error (and associated alarm).

---

- Recalculates the relevant polynomial coefficients and offset adjustment fields each time you perform a complete calibration cycle. The system also discards internally held previous settings at this point.

The audit trail functionality is similar to that produced by the linear method with the exception that a midpoint change event exists.

### D.1.5 Offset PRT Device Calibration

The conversion types (OffsetCalDIN and OffsetCalUS) enable you to crudely calibrate a PRT device across the linear range defined by the respective resistance-to-temperature lookup tables. The calibration consists of simply determining an offset from the temperature table conversion value.

**Operator Interface** The operator performs the calibration in exactly the same manner as required for the ADC calibration offset point defined previously.

**PRT Input Object** The calibration process uses the following fields:

- Offset adjustment field [double]
- Calibration control field [char]

Conversions are performed at the IO module using the following mechanism:

- Resistance measured by IO board PRT input.
- Conversion made using selected lookup table.
- $Temp\_actual = Temp\_conv - Offset\_adjust$

**Offset PRT Calibration Control Mechanism** The displays task, as with the ADCs, marks the calibration control field when:

- You performsan offset adjustment capture.

When you modify the calibration control field of a PRT the control task:

- Captures the measured temperature reading into the offset data field.

---

**Note:** The previous offset value is discarded. Additionally, there is no timer associated with an offset calibration type device. Finally, the audit trail functionality is similar to that produced for ADCs.

---

### D.1.6 Linear Two-point Device PRT Calibration

The two-point calibration of PRTs operates in the same manner as the two-point calibration for ADCs. The displays task is responsible for marking the calibration control field when:

- You change the LOrange field.
- You change the HRange field.
- You perform an offset adjustment data capture.

When you modify the calibration control field the control task:

- Captures and places the resistance reading into the relevant data field and logs the previous settings.
- Initiates a calibration timer that monitors the operator.
- Continues a timer until you set the second of the two points.

---

**Note:** If the timer completes before you set the second point, the device reverts to its original (logged) settings and the calibration cycle aborts with an error (and associated alarm).

---

- Updates the relevant gradient, offset and offset adjustment fields each time you perform a complete calibration cycle. The system also discards internally held previous settings at this point

The audit trail handling is the same as for ADCs.

**PRT Input Object** The calibration process uses the following fields:

PRT Object Field	Description	Data Type
LastGood field	Holds the last good value read from the PRT input.	[double]
LOrange field	The lowest value of the inputs total range to use in the calibration.	[double]
LOresist field	The measured resistance at the LOrange point.	[double]
Hlrange field	The highest value of the inputs total range to use in the calibration.	[double]
Hlresist field	The measured resistance at the Hlrange point.	[double]
Gradient field	The gradient of the line between the LO and Hi range setpoints.	[double]
Off set field	The actual offset value used by the ADC, updated after a successful calibration.	[double]
Off set adjustment field	The offset entered during the calibration.	[double]
Calibration control field	Keeps track of the calibration status.	[char]

Where:

$$Gradient = \frac{HIScale - LOScale}{HIResist - LOResist}$$

$$Offset = LOScale - (LOResist \times Gradient)$$

Then each analogue input current reading to plant value conversion is performed using:

$$Temperature = (Resistance \times Gradient) + Offset - Offset_{Adjust}$$

## D.1.7 Non-linear Three-point Curve-Fit PRT Device Calibration

This method enables you to calibrate a PRT device across a non-linear range by entering high, mid, and low range temperature setpoints. The selection of these setpoints is user definable and thus device dependent.

**Operator Interface** Same as the process for a three-point ADC calibration

**PRT Input Object** The calibration process uses the following fields:

PRT Object Field	Description	Data Type
LastGood field	Holds the last good value read from the analogue input.	[double]
LOrange field	The lowest value of the inputs total range to use in the calibration.	[double]
LOresist field	The measured resistance at the LOrange point.	[double]
MIDrange field	The mid range value of the inputs total range to use in the calibration.	[double]
MIDresist field	The measured resistance at the MIDrange point.	[double]
Hlrange field	The highest value of the inputs total range to use in the calibration.	[double]
Hlresist field	The measured resistance at the Hlrange point.	[double]
CurveCoeff_1 field	Calculated coefficient 1 value for use in the curve fit equation.	[double]
CurveCoeff_2 field	Calculated coefficient 2 value for use in the curve fit equation.	[double]
CurveCoeff_3 field	Calculated coefficient 3 value for use in the curve fit equation.	[double]
Calibration control field	Keeps track of the calibration status.	[char]

Then each PRT input resistance reading to plant value conversion is performed using the second order curve equation:

$$Value = (Coef1 \times Resistance^2) + (Coef2 \times Resistance) + Coef3 - Offset_{Adjust}$$

## D.2 Analogue Output Calibration

Do not confuse process calibration with the production hardware calibration you perform on all IO boards subsequent to manufacturing. You perform hardware calibration after production to determine the relationship between analogue converter counts and current in mA for Digital to Analog Converters (DACs). This calibration process essentially “fixes” each individual output channel the way in which the S600+ outputs the current.

Process calibration does not alter this counts-to-measure relationship.

In the case of DACs, calibration defines the adjustment made to the transducer engineer units before driving the output current. Thus; after process calibration, the analogue device produces a current equal to the one that would be produced by an ideal device.

### D.2.1 Calibration Control Requirements

1. You must disconnect any device connected to the analog output. The current driven by the device changes abruptly during calibration and this might damage the device.
2. You cannot perform part of a calibration and effectively impair the integrity of field output data. The calibration control task uses a configurable time to monitor all calibration operations. Thus, if you perform part of a calibration but do not complete the process prior to timeout, the control task reverts all calibration data to its initial state prior to the start of the calibration operation. The calibration terminates and an error displays. The default timeout setting for the analog output calibration is **20** minutes. This time value is **not** configurable.



## D.2.2 DAC Device Calibration

This is a linear calibration. The purpose is to adjust the current for the LOW and the HIGH values of the DAC's scale.

**Operator Interface** To calibrate the DAC device:

1. Connect a digital multimeter to read the current (mA) from the analog output that you will calibrate.
2. Navigate to an analog output channel requiring calibration.
3. Move to the calibration display page. Press **CHNG** to start calibration.

```
DAC01
I/O01 DAC 01

FOR CALIBRATION
PRESS
CHANGE      *
```

---

```
P51.3 <of 3>
```

4. Calibrate the low current. Use the up and down arrows from the keypad to adjust the current until the measured current is equal to the expected current (the one shown on the display). Once they are equal, press **Enter** to go to the next step.

```
DAC01
I/O01 DAC 01

          4mA
UP       - INCREASE
DOWN    - DECREASE
ENTER   - NEXT
CLEAR   - ABORT
```

---

**Note:** In the event the calibration offset limits are reached, the system displays a message for the operator on the display.

---

5. Calibrate the high current. Use the up and down arrows from the keypad to adjust the current until the measured current is equal to the expected current (the one shown on the display). Once they are equal, press **Enter** to go to the next step.

```
DAC01
I/O01 DAC 01

          20mA
UP       - INCREASE
DOWN    - DECREASE
ENTER   - ACCEPT
CLEAR   - ABORT
```

- Repeat steps 4 and 5 by pressing keypad 2 until you can see no further improvement. When no improvement can be seen, select **1** (SAVE CHANGES) to save the changes.

```
DAC01
I/O01 DAC 01

CALIBRATION FINISHED

1. SAVE CHANGES
2. GO AGAIN
2. ABORT
```

- In order to make the adjustments consistent through a cold start, perform a system backup. If you do not do this, you lose the changes on a cold start (although they persist on a warm start).

---

**Notes:**

- The system saves values for a specific board. If you change the board, you **must** redo the calibration.
- In steps 4 or 5, press **CLEAR** to abort the process.

**DAC Control Mechanism**

The calibration control task monitors each of the DAC objects calibration control fields. The task remains idle until a control field is set indicating a calibration request has been made. The calibration control field of each of the systems DAC objects identifies what type of modification has been requested. The display task is responsible for marking the calibration control field when:

- You change the low calibration offset (calibrate the low current).
- You change the high calibration offset (calibrate the high current).

When you modify the calibration control field, the control task:

- Captures and saves the current calibration offsets.
- Initiates a calibration time that monitors the operation.
- Continues the timer until you save the calibration changes.

---

**Note:** If the timer completes before you save the calibration changes, the device reverts to its original (logged) settings and the calibration cycle aborts with an error (and associated alarm).

---

- Updates relevant offset adjustment fields each time you perform a complete calibration cycle. The system discards internally held previous settings at this point.

When you make changes, an audit trail print indicates that a device calibration has been performed and logs:

- The operator making the change.
- The change made.

This printout uses a system event generation mechanism and has the same data attributes as any other system event. Additionally, the

system stores the event data in the event record buffer (as is the case with all events generated by the flow computer). For example:

```
11/02/2011 07:25:36 S600 FP USER: LOGGED IN LEVEL: 1
11/02/2011 07:26:45 S600 CALIBRATION STARTED FOR DAC01
11/02/2011 07:26:45 S600 CALIBRATION ABORTED FOR DAC01

11/02/2011 07:26:55 S600 CALIBRATION STARTED FOR DAC01
11/02/2011 07:46:55 S600 CALIBRATION TIMED OUT FOR DAC01
11/02/2011 07:46:55 S600 CALIBRATION ABORTED FOR DAC01

11/02/2011 07:50:45 S600 CALIBRATION STARTED FOR DAC01
11/02/2011 08:05:52 S600 CALIBRATION POINTS SAVED FOR DAC01
```

*[This page is intentionally left blank.]*

# Appendix E – S600+ Database Objects and Fields

## In This Chapter

E.1	Database Objects.....	E-2
E.1.1	ADC.....	E-2
E.1.2	ALARM.....	E-3
E.1.3	ALARMHIST.....	E-3
E.1.4	ARRTXT.....	E-3
E.1.5	CALCALMITEM.....	E-4
E.1.6	CALCTAB.....	E-5
E.1.7	CONFTAB.....	E-6
E.1.8	CUMTOT.....	E-6
E.1.9	DACOUT.....	E-6
E.1.10	DIGIO.....	E-6
E.1.11	DOSETUP.....	E-7
E.1.12	DPCELL.....	E-7
E.1.13	EVENTHIST.....	E-8
E.1.14	FREQT.....	E-8
E.1.15	HART.....	E-8
E.1.16	HARTTAB.....	E-10
E.1.17	IOASSIGN.....	E-10
E.1.18	KPINT.....	E-10
E.1.19	KPINTARR.....	E-10
E.1.20	KPREAL.....	E-12
E.1.21	KPREALARR.....	E-12
E.1.22	KPSTRING.....	E-13
E.1.23	LOG.....	E-13
E.1.24	MULTI.....	E-14
E.1.25	PID.....	E-14
E.1.26	PIP.....	E-14
E.1.27	POP.....	E-14
E.1.28	PRDTOT.....	E-14
E.1.29	PRT.....	E-15
E.1.30	PRV_CTL.....	E-16
E.1.31	REP00 – REP39.....	E-17
E.1.32	SECURITY.....	E-17
E.1.33	SYSOBJ.....	E-17
E.1.34	TASK.....	E-17
E.1.35	TOTTAB.....	E-17
E.2	Database Fields.....	E-18
E.2.1	Alarm Text Tables.....	E-19
E.2.2	Batching/Totalisation.....	E-19
E.2.3	DIGIO Setup Table.....	E-19
E.2.4	DP Stack Type.....	E-19
E.2.5	DP Live/Check Mode Selection.....	E-19
E.2.6	DP Cut Off Mode.....	E-19
E.2.7	Event History Type.....	E-19
E.2.8	HART Poll Format.....	E-20
E.2.9	HART Master Mode.....	E-20
E.2.10	I/O (P144) PID Type.....	E-20
E.2.11	Prover (P154) Dual Chronometry Switch Pair.....	E-20
E.2.12	Prover (P154) Type.....	E-21
E.2.13	Password Tables.....	E-21
E.2.14	Truth Tables.....	E-21
E.2.15	Turbine Meter Setup Tables.....	E-21
E.3	Mode Tables.....	E-21
E.3.1	ADC/PRT Modes (MODE TAB PLANTI/O).....	E-21
E.3.2	CALC/ALM Auto Switch Modes.....	E-22
E.3.3	CALC/ALM modes (MODE TAB CALC).....	E-22
E.3.4	Density Transducer Modes (MODE TAB DENS IP).....	E-22
E.3.5	DP Modes (MODE TAB DP STACK).....	E-22

This appendix provides a alphabetic listing of the database objects you can access through the Connect Wizard, which is part of the Reports Editor, Modbus Editor, LogiCalc Editor, Display Editor, and System Editor.

## E.1 Database Objects

This section provides an alphabetic listing of all database objects.

### E.1.1 ADC

Object	Descriptor	Type
DESC	Descriptor	String
CONVTYP	ADC conversion type (integer)	Byte
TAG	Tag name associated with the object	String
MODE	Integer mode / field selection for 'INUSE' field.	Byte
HEALTH	Measurement status. 0 if OK	Byte
INUSE	Value copied from MEASURED, KEYPAD, AVERAGE , LASTGOOD, or WEIGHTED as indexed by the 'MODE' field	Double
KEYPAD	Value used in KEYPAD/ KEYPAD-F mode	Double
MEASURED	Measured value	Double
CURRENT	Measured current	Double
LOSCALE	Low ADC scale value (4mA or 0mA)	Double
HISCALE	High ADC scale value 20mA	Double
LOCALIB	Low engineering value *	Double
MIDCALIB	Mid engineering value *	Double
HICALIB	High engineering value *	Double
LOCURRENT	Snapshot low current *	Double
MIDCURRENT	Snapshot mid current *	Double
HICURRENT	Snapshot high current *	Double
GRADIENT	Calculated gradient *	Double
OFFSET	Calculated offset *	Double
OFFSETADJ	In-use offset adjust *	Double
COEFF1	Calculated low calibration coefficient *	Double
COEFF2	Calculated mid calibration coefficient *	Double
COEFF3	Calculated high calibration coefficient *	Double
ROC	The maximum rate at which the 'INUSE' field can change, per second	Double
SETPPOINT	Expected value	Double
DEVIATION	Maximum allowed variation from 'SETPPOINT'	Double
AVERAGE	Rolling average of the MEASURED field: AVERAGE=(AVERAGE+MEASURED)/2	Double
LASTGOOD	Last MEASURED value	Double
HIHILIM	High – high alarm limit	Double
HILIM	High alarm limit	Double

Object	Descriptor	Type
LOLIM	Low alarm limit	Double
LOLOLIM	Low – low alarm limit	Double
OFFSETENTRY	Operator offset adjust field *	Double
LOFAIL	Under-range current limit	Double
HIFAIL	Over range current limit	Double
WEIGHTED	Time/flow weighted average (updated at the end of the period)	Double
MODETEXT	Text string associated with the integer 'MODE' field. See mode table	String
CONVTEXT	ADC type	String
ID	For internal use	Double
UNITTEST	Units associated with the object	String
DESCSHORT	Short descriptor of the object	String

\* These fields are used for field calibration.

## E.1.2 ALARM

Object	Description	Type
DESC	Descriptor	String
STATUS	Current alarm status for alarms 1 – 16	Word
UNACC	Current alarm accept status for alarms 1 – 16	Word
INHIBIT	Alarm inhibit bit mask for alarms 1 – 16	Word
SUPPRESS	Current alarm suppression bit mask for alarms 1 – 16	Word

## E.1.3 ALARMHIST

Object	Description	Type
PRINTED	Printed flag	Byte
STATE	Current status for alarms (ALM_SET, ALM_CLR, or ALM_ACC)	Byte
NUM	Alarm number	Byte
ID	Alarm audit ID counter	Word
ENRONID	Enron Modbus ID	Word
ENRONBIT	Enron bitmask	Word
LIMIT	Alarm limit	Double
VALUE	Value when the alarm was raised	Double

## E.1.4 ARRTXT

Object	Description	Type
DESC	Descriptor	String
0	Array text 0	String
1	Array text 1	String
2	Array text 2	String
3	Array text 3	String
4	Array text 4	String
5	Array text 5	String
6	Array text 6	String
7	Array text 7	String
8	Array text 8	String
9	Array text 9	String

Object	Description	Type
10	Array text 10	String
11	Array text 11	String
12	Array text 12	String
13	Array text 13	String
14	Array text 14	String
15	Array text 15	String
16	Array text 16	String
17	Array text 17	String
18	Array text 18	String
19	Array text 19	String
20	Array text 20	String
21	Array text 21	String
22	Array text 22	String
23	Array text 23	String
24	Array text 24	String
25	Array text 25	String
26	Array text 26	String
27	Array text 27	String
28	Array text 28	String
29	Array text 29	String
30	Array text 30	String
31	Array text 31	String
32	Array text 32	String
33	Array text 33	String
34	Array text 34	String
35	Array text 35	String
36	Array text 36	String
37	Array text 37	String
38	Array text 38	String
39	Array text 39	String

### E.1.5 CALCALMITEM

Object	Description	Type
DESC	Descriptor	String
MODE	Integer mode / field selection for 'INUSE' field. Refer to <i>CALC/ALM Modes, Density Transducer Modes, and CALC/ALM Auto Switch Modes.</i>	Byte
INUSE	Value copied from KEYPAD, CALC1, CALC2, CALC3, or CALC4 as indexed by the 'MODE' field	Double
KEYPAD	Value used in KEYPAD/ KEYPAD-F mode	Double
CALC1	Calculation result 1	Double
CALC2	Calculation result 2	Double
CALC3	Calculation result 3	Double
CALC4	Calculation result 4	Double
HIHILIM	High – High alarm limit	Double
HILIM	High alarm limit	Double
LOLIM	Low alarm limit	Double
LOLOLIM	Low – low alarm limit	Double
WEIGHTED	Rolling time/flow weighted average	Double



<b>Object</b>	<b>Description</b>	<b>Type</b>
MODETEXT	Mode text	String
UNITTEXT	Units associated with the object	String
DESCSHORT	Short descriptor of the object	String

## E.1.6 CALCTAB

<b>Object</b>	<b>Description</b>	<b>Type</b>
DESC	Descriptor	String
TYPE	Calculation type, i.e., AGA3 = 104	Word
INPUT01	CONFTAB index for input 1	Word
INPUT02	CONFTAB index for input 2	Word
INPUT03	CONFTAB index for input 3	Word
INPUT04	CONFTAB index for input 4	Word
INPUT05	CONFTAB index for input 5	Word
INPUT06	CONFTAB index for input 6	Word
INPUT07	CONFTAB index for input 7	Word
INPUT08	CONFTAB index for input 8	Word
INPUT09	CONFTAB index for input 9	Word
INPUT10	CONFTAB index for input 10	Word
INPUT11	CONFTAB index for input 11	Word
INPUT12	CONFTAB index for input 12	Word
INPUT13	CONFTAB index for input 13	Word
INPUT14	CONFTAB index for input 14	Word
INPUT15	CONFTAB index for input 15	Word
INPUT16	CONFTAB index for input 16	Word
INPUT17	CONFTAB index for input 17	Word
INPUT18	CONFTAB index for input 18	Word
INPUT19	CONFTAB index for input 19	Word
INPUT20	CONFTAB index for input 20	Word
OUTPUT01	CONFTAB index for output 1	Word
OUTPUT02	CONFTAB index for output 2	Word
OUTPUT03	CONFTAB index for output 3	Word
OUTPUT04	CONFTAB index for output 4	Word
OUTPUT05	CONFTAB index for output 5	Word
OUTPUT06	CONFTAB index for output 6	Word
OUTPUT07	CONFTAB index for output 7	Word
OUTPUT08	CONFTAB index for output 8	Word
OUTPUT09	CONFTAB index for output 9	Word
OUTPUT10	CONFTAB index for output 10	Word
OUTPUT11	CONFTAB index for output 11	Word
OUTPUT12	CONFTAB index for output 12	Word
OUTPUT13	CONFTAB index for output 13	Word
OUTPUT14	CONFTAB index for output 14	Word
OUTPUT15	CONFTAB index for output 15	Word
OUTPUT16	CONFTAB index for output 16	Word
OUTPUT17	CONFTAB index for output 17	Word
OUTPUT18	CONFTAB index for output 18	Word
OUTPUT19	CONFTAB index for output 19	Word
OUTPUT20	CONFTAB index for output 20	Word
ERRORNUM	Calculation error number (for diagnostics)	Word
DESCSHORT	Short descriptor of the object	String

### E.1.7 CONF TAB

Object	Description	Type
DESC	Descriptor	String
OBJTYPE	Object type	Word
OBJINDEX	Object index	Word
OBJFIELD	Object field	Word
BITNO	Bit number	Word
DESCSHORT	Short descriptor of the object	String

### E.1.8 CUMTOT

Object	Description	Type
DESC	Descriptor	String
ROLLOVER	The power of 10 at which rollover occurs	Byte
DECPPLACE	Number of figures after the decimal point stored in the 'TOTAL' field, all others are held in the 'REMAINDER' field	Byte
SCALE	Not used	Double
PREVIOUS	Not used	Double
SNAPSHOT	Cumulative total at the last period end	Double
TOTAL	Current cumulative total (tri-reg)	Double
val_1	For internal use	Double
REMAINDER	The remainder not included in TOTAL	Double
rem_1	For internal use	Double
SNAPTIMETEXT	The time when SNAPSHOT was updated	String
UNITTEXT	Units associated with the object	String
DESCSHORT	Short descriptor of the object	String

### E.1.9 DACOUT

Object	Description	Type
DESC	Descriptor	String
CONVTYP	DAC conversion type (integer)	Byte
TAG	Tag name associated with the object	String
RAW	DAC output value (engineering units)	Double
LOSCALE	Low scale output value (4mA or 0mA)	Double
HISCALE	High scale output value (20mA)	Double
LOOFFSET	Low calibration offset	Double
HIOFFSET	High calibration offset	Double
CONVTEXT	DAC type	String
UNITTEXT	Units associated with the object	String
DESCSHORT	Short descriptor of the object	String

### E.1.10 DIGIO

Object	Description	Type
DESC	Description	String
TAG	Tag name associated with the object	String
HEALTH	Measurement status. 0 if OK	Byte
INPUT	Digital output status, where bits 0 to 11 represent digital outputs 1 to 12	Word
OUTPUT	Digital input status, where bits 0 to <i>n</i> represent digital inputs 1 to <i>n</i>	Word
RAWIN	As INPUT	Word

Object	Description	Type
RAWOUT	As OUTPUT	Word
INPUTTEXT	Status text	String
OUTPUTTEXT	Status text	String

### E.1.11 DOSETUP

Object	Description	Type
DESC	Descriptor	String
SENSE	Channel mode: normal, invert, pulse, or pulse off	Word
WIDTH	Duration of the pulse in mSec, if channel is set to pulse or pulse off.	Word

### E.1.12 DPCELL

Object	Description	Type
DESC	Descriptor	String
MODE	Integer mode / field selection for 'INUSE' field. Refer to <i>DP Modes</i> .	Byte
DPTYPE	DP stack type. Refer to <i>DP Stack Type</i> .	Byte
DPCOMODE	DP cut off mode. Refer to <i>DP Cutoff Mode</i> .	Byte
LIVECHK	Live/check status. Refer to <i>DP Live/Check Mode Selection</i> .	Byte
CELL	Current active cell.	Word
INUSE	Value copied from MEASURED or CHECK as indexed by the MODE field or the keypad.	Double
MEASURED	DP measured value.	Double
KEYPAD	Value used in KEYPAD / KEYPAD-F mode	Double
CHECK	DP for testing.	Double
CUTOFF	Value below which the S600+ does not totalize DP measurements	Double
FLOWRATE	Calculated flow rate $\text{Sqrt}(\text{DP}) * \text{Const}$	Double
FRCONST	Flow rate constant	Double
SWITCHUP	The switch-up point between two input cells, expressed as a percentage of the range of the lower cell. The S600+ uses this value for all cell ranges	Double
SWITCHDN	The switch-down point between two input cells, expressed as a percentage of the range of the lower cell. The S600+ uses this value for all cell ranges	Double
DISCREP	The discrepancy allowed between the readings of active input cells in the operating range. The value is defined as a percentage of the high scale value from the lower of the two cells.	Double
DISCTOUT	The period of time during which the S600+ ignores the discrepancy between the readings of available transducers. When the duration of the discrepancy exceeds this time limit, the S600+ raises an alarm.	Double
HIHILIM	High – high alarm limit	Double
HILIM	High alarm limit	Double
LOLIM	Low alarm limit	Double

Object	Description	Type
LOLOLIM	Low – low alarm limit	Double
MODETEXT	Mode text	String
OBJTYPE1	Object type for DP cell 1	Word
OBJTYPE2	Object type for DP cell 2	Word
OBJTYPE3	Object type for DP cell 3	Word
OBJTYPE4	Object type for DP cell 4	Word
OBJTYPE5	Object type for DP cell 5	Word
OBJTYPE6	Object type for DP cell 6	Word
OBJINDEX1	Object index for DP cell 1	Word
OBJINDEX2	Object index for DP cell 2	Word
OBJINDEX3	Object index for DP cell 3	Word
OBJINDEX4	Object index for DP cell 4	Word
OBJINDEX5	Object index for DP cell 5	Word
OBJINDEX6	Object index for DP cell 6	Word
HEALTH	Health status byte	Byte
UNITTEXT	Units associated with the object	String
DESCSHORT	Short descriptor of the object	String

### E.1.13 EVENTHIST

Object	Descriptor	Type
EVENT	Event type.	Byte
PRINTED	Printed flag	Byte
ID	Unique ID	Word
ENRONID	Enron Modbus ID	Word
ENRONBIT	Enron bitmask	Word

### E.1.14 FREQT

Object	Descriptor	Type
DESC	Descriptor	String
TAG	Tag name associated with the object	String
HEALTH	Measurement status. 0 if OK	Byte
PERIOD	Measured period	Double
FREQ	Measured frequency	Double
UNITTEXT	Units associated with the object	String
DESCSHORT	Short descriptor of the object	String

### E.1.15 HART

Object	Descriptor	Type
DESC	Descriptor	String
MODE	Integer mode / field selection for 'INUSE' field. Refer to " <i>HART Modules</i> ."	Byte
ID	For internal use	Double
TAG	Tag (HART revision 5 command 13)	String
HEALTH	Measurement status. 0 if OK. Bit 0 is set for over range, bit 1 set for under range. These are back-calculated from the PV, UPRANGE and LORANGE when STATUS2 indicates analogue output saturation or PV is out of limits. Note: Bit 6 is set when nothing is connected (Status2=128).	Byte

<b>Object</b>	<b>Descriptor</b>	<b>Type</b>
STATUS2 / SECOND_STAT_BYTE	Second status byte (HART revision 5)	Byte
PVUNIT / PV_UNIT_CODE	Primary variable unit code (HART revision 5 command 3)	Byte
SVUNIT / SV_UNIT_CODE	Secondary variable unit code (HART revision 5 command 3)	Byte
TVUNIT / TV_UNIT_CODE	Tertiary variable unit code (HART revision 5 command 3)	Byte
FVUNIT / FV_UNIT_CODE	Fourth variable unit code (HART revision 5 command 3)	Byte
UNIVCMDREV / UNIV_COMMAND_REV	Universal command revision (HART revision 5 command 0)	Byte
TXCMDREV / TX_COMMAND_REV	Transmitter Specific Command Revision (HART revision 5 command 0)	Byte
SWREV / SW_REV	Software Revision (HART revision 5 command 0)	Byte
HWREV / HW_REV	Hardware Revision (HART revision 5 command 0)	Byte
STATUS1 / FIRST_STAT_BYTE	First status byte (HART revision 5)	Byte
INUSE	Value copied from PV, KEYPAD, AVERAGE, LASTGOOD, or WEIGHTED as indexed by the 'MODE' field	Double
KEYPAD	Value used in KEYPAD/ KEYPAD-F mode	Double
ROC	The maximum rate at which the 'INUSE' field can change, per second	Double
SETPOINT	Expected value	Double
DEVIATION	Maximum allowed variation from 'SETPOINT'	Double
AVERAGE	Rolling average of the MEASURED field: $AVERAGE=(AVERAGE+MEASURED)/2$	Double
LASTGOOD / LAST_GOOD	Last MEASURED value	Double
HHILIM / HH_LIMIT	High – high alarm limit	Double
HILIM / H_LIMIT	High alarm limit	Double
LOLIM / L_LIMIT	Low alarm limit	Double
LOLOLIM / LL_LIMIT	Low – low alarm limit	Double
CURRENT	Current mA (HART revision 5 command 3)	Double
PV	Primary variable (HART revision 5 command 3)	Double
SV	Secondary variable (HART revision 5 command 3)	Double
TV	Tertiary variable (HART revision 5 command 3)	Double
FV	Fourth variable (HART revision 5 command 3)	Double
UPRANGE / UPPER_RANGE	Upper range value from HART transmitter (HART revision 5 command 15)	Double
LORANGE / LOWER_RANGE	Lower range value from HART transmitter (HART revision 5 command 15)	Double
UPPERLIM / UPPER_LIM	Upper Sensor Limit (HART revision 5 command 14)	Double
LOWERLIM / LOWER_LIM	Lower Sensor Limit (HART revision 5 command 14)	Double

Object	Descriptor	Type
WEIGHTED	Rolling time/flow weighted average	Double
MODETEXT	Mode text	String
UNITTEXT	Unit text	String
DESCSHORT	Short description	String

### E.1.16 HARTTAB

Object	Descriptor	Type
DESC	Descriptor	String
POLLFMT	Hart module type. Refer to <i>HART Poll Format</i> .	Byte
MSTMODE	Primary / secondary master mode. Refer to <i>HART Master Mode</i> .	Byte
SWVER	Module (P188) software version number	Word
ALTVER	Module (P188) Altera version number	Word
ALTCHANS	Number of channels supported	Word

### E.1.17 IOASSIGN

Object	Descriptor	Type
DESC	Descriptor	String
INUSE	Current in-use value	Double
MODE	Integer mode / field selection for 'INUSE' field	Byte
KEYPAD	Value used in KEYPAD / KEYPAD-F mode	Double
ROC	Maximum rate at which the 'INUSE' field can change, per second	Double
SETPOINT	Expected value	Double
DEVIATION	Maximum allowed variation from 'SETPOINT'	Double
AVERAGE	Rolling average of the MEASURED field: $AVERAGE = AVERAGE + MEASURED / 2$	Double
LASTGOOD/ LAST_GOOD	Last MEASURED value	Double
HIHILIM / HH_LIMIT	High – high alarm limit	Double
HILIM / H_LIMIT	High alarm limit	Double
LOLIM / LL_LIMIT	Low alarm limit	Double
LOLOLIM / LL_LIMIT	Low – low alarm limit	Double
UNITTEXT	Units associated with the object	String
DESCSHORT	Short descriptor of the object	String

### E.1.18 KPINT

Object	Descriptor	Type
DESC	Descriptor	String
VALUE	Value (1 to 39)	Word
STATUS	Status text for VALUE field (1 to 39)	String

### E.1.19 KPINTARR

Object	Descriptor	Type
DESC	Descriptor	String
0	Value 0	Word

<b>Object</b>	<b>Descriptor</b>	<b>Type</b>
1	Value 1	Word
2	Value 2	Word
3	Value 3	Word
4	Value 4	Word
5	Value 5	Word
6	Value 6	Word
7	Value 7	Word
8	Value 8	Word
9	Value 9	Word
10	Value 10	Word
11	Value 11	Word
12	Value 12	Word
13	Value 13	Word
14	Value 14	Word
15	Value 15	Word
16	Value 16	Word
17	Value 17	Word
18	Value 18	Word
19	Value 19	Word
20	Value 20	Word
21	Value 21	Word
22	Value 22	Word
23	Value 23	Word
24	Value 24	Word
25	Value 25	Word
26	Value 26	Word
27	Value 27	Word
28	Value 28	Word
29	Value 29	Word
30	Value 30	Word
31	Value 31	Word
32	Value 32	Word
33	Value 33	Word
34	Value 34	Word
35	Value 35	Word
36	Value 36	Word
37	Value 37	Word
38	Value 38	Word
39	Value 39	Word
STATUS1	Status text for value 0	String
STATUS2	Status text for value 1	String
STATUS3	Status text for value 2	String
STATUS4	Status text for value 3	String
STATUS5	Status text for value 4	String
STATUS6	Status text for value 5	String
STATUS7	Status text for value 6	String
STATUS8	Status text for value 7	String
STATUS9	Status text for value 8	String
STATUS10	Status text for value 9	String
STATUS11	Status text for value 10	String

<b>Object</b>	<b>Descriptor</b>	<b>Type</b>
STATUS12	Status text for value 11	String
STATUS13	Status text for value 12	String
STATUS14	Status text for value 13	String
STATUS15	Status text for value 14	String
STATUS16	Status text for value 15	String
STATUS17	Status text for value 16	String
STATUS18	Status text for value 17	String
STATUS19	Status text for value 18	String
STATUS20	Status text for value 19	String
STATUS21	Status text for value 20	String
STATUS22	Status text for value 21	String
STATUS23	Status text for value 22	String
STATUS24	Status text for value 23	String
STATUS25	Status text for value 24	String
STATUS26	Status text for value 25	String
STATUS27	Status text for value 26	String
STATUS28	Status text for value 27	String
STATUS29	Status text for value 28	String
STATUS30	Status text for value 29	String
STATUS31	Status text for value 30	String
STATUS32	Status text for value 31	String
STATUS33	Status text for value 32	String
STATUS34	Status text for value 33	String
STATUS35	Status text for value 34	String
STATUS36	Status text for value 35	String
STATUS37	Status text for value 36	String
STATUS38	Status text for value 37	String
STATUS39	Status text for value 38	String
STATUS40	Status text for value 39	String

### E.1.20 KPREAL

<b>Object</b>	<b>Descriptor</b>	<b>Type</b>
DESC	Descriptor	String
VALUE	Value	Double
UNITTEXT	Units associated with the object	String
DESCSHORT	Short descriptor of the object	String

### E.1.21 KPREALARR

<b>Object</b>	<b>Descriptor</b>	<b>Type</b>
DESC	Descriptor	String
0	Value 0	Double
1	Value 1	Double
2	Value 2	Double
3	Value 3	Double
4	Value 4	Double
5	Value 5	Double
6	Value 6	Double
7	Value 7	Double
8	Value 8	Double



<b>Object</b>	<b>Descriptor</b>	<b>Type</b>
9	Value 9	Double
10	Value 10	Double
11	Value 11	Double
12	Value 12	Double
13	Value 13	Double
14	Value 14	Double
15	Value 15	Double
16	Value 16	Double
17	Value 17	Double
18	Value 18	Double
19	Value 19	Double
20	Value 20	Double
21	Value 21	Double
22	Value 22	Double
23	Value 23	Double
24	Value 24	Double
25	Value 25	Double
26	Value 26	Double
27	Value 27	Double
28	Value 28	Double
29	Value 29	Double
30	Value 30	Double
31	Value 31	Double
32	Value 32	Double
33	Value 33	Double
34	Value 34	Double
35	Value 35	Double
36	Value 36	Double
37	Value 37	Double
38	Value 38	Double
39	Value 39	Double
UNITTEXT	Units associated with the object	String
DESCSHORT	Short descriptor of the object	String

### E.1.22 KPSTRING

<b>Object</b>	<b>Descriptor</b>	<b>Type</b>
DESC	Descriptor	String
VALUE	Value	String

### E.1.23 LOG

<b>Object</b>	<b>Descriptor</b>	<b>Type</b>
DESC	Descriptor	String
TYPE	Object type associated with the log, i.e., ALARMHIST or EVENTHIST	Byte
HEAD	Index to the oldest object	Word
COUNT	Total number of alarms / events. This may be different than the value of Head because one event may use several EVENTHIST objects	Word

Object	Descriptor	Type
MODE	Integer mode / field selection for 'INUSE' field.	Word
RECORDS	Number of ALARMHIST or EVENTHIST objects associated with this log	Word

### E.1.24 MULTI

Object	Descriptor	Type
DESC	Descriptor	String
OUTPUT	Control value	Word
INPUT	Status value	Word
CONTROL	Control text	String
STATUS	Status text	String

**Note:** CONTROL and STATUS text result from a Truth Table lookup.

### E.1.25 PID

Object	Descriptor	Type
DESC	Descriptor	String
DACCTL	For internal use only	Byte

### E.1.26 PIP

Object	Descriptor	Type
DESC	Descriptor	String
TAG	Tag name associated with the object	String
HEALTH	Measurement status. 0 if OK	Byte
GOOD	Good pulse counter	Double
BAD	Bad pulse counter	Double
DELTA GOOD	For internal use	Double
DELTA BAD	For internal use	Double
FREQ	Measured pulse frequency	Double
TIME	P144: the time main board last polled the I/O module for pulse count P154: the exact time the I/O module read the hardware pulse counters	Double
KFACTOR	For internal use	Double

### E.1.27 POP

Object	Descriptor	Type
DESC	Descriptor	String
TAG	Tag name associated with the object	String
FREQ	Pulse output frequency. Valid range is 0.5 to 500 Hertz (this is, 2 seconds to 1 mS)	Double
GRABSIZE	The number of units per pulse	Double
PREVTOTAL	Snap shot taken at last calculation cycle	Double
REM	Pulse fraction awaiting output	Double
PULSEOUT	Whole pulses awaiting output	Double

### E.1.28 PRDTOT

Object	Descriptor	Type
DESC	Descriptor	String

<b>Object</b>	<b>Descriptor</b>	<b>Type</b>
ROLLOVER	The power of 10 at which rollover occurs	Byte
DECPLACE	Number of figures after the decimal point stored in the 'TOTAL' field, all others are held in the 'REMAINDER' field	Byte
SCALE	Not used	Double
PREVIOUS	Previous period total	Double
SNAPSHOT	Snapshot cumulative at the last period end	Double
TOTAL	Current period total	Double
Val	Current period total	Double
REMAINDER	Not used	Double
Rem	Not used	Double
ALMHEADSNAP	The index of the oldest alarm history object at the last period end	Word
ALMHEADPREV	The index of the oldest alarm history object at the start of the last period	Word
EVTHEADSNAP	As ALMHEADSNAP, but for events	Word
EVTHEADPREV	As ALMHEADPREV, but for events	Word
ALMCOUNT	The number of alarms in the previous period	Word
ALMCOUNTSNAP	The alarm counter at the last period end	Word
ALMCOUNTPREV	The alarm counter at the start of the last period	Word
EVTCOUNT	The number of events in the previous period	Word
EVTCOUNTSNAP	As ALMCOUNTSNAP, but for events	Word
EVTCOUNTPREV	As ALMCOUNTPREV, but for events	Word
ALMLOG	Alarm history – for reports only	Alarm
EVTLOG	Event history – for reports only	Event
SNAPTIMETEXT	The time when SNAPSHOT was updated	String
UNITTEXT	Units associated with the object	String
DESCSHORT	Short descriptor of the object	String

### E.1.29 PRT

<b>Object</b>	<b>Descriptor</b>	<b>Type</b>
DESC	Descriptor	String
RTDTYP	Type of transducer	Byte
TAG	Tag name associated with the object	String
MODE	Integer mode / field selection for 'INUSE' field. Refer to <i>ACD/PRT Modes</i> .	Byte
HEALTH	Measurement status. 0 if OK	Byte
INUSE	Value copied from MEASURED, KEYPAD, AVERAGE, LASTGOOD, or WEIGHTED as indexed by the 'MODE' field	Double
KEYPAD	Value used in KEYPAD/ KEYPAD-F mode	Double
MEASURED	Measured temperature	Double
RESISTANCE	Measured resistance	Double
LOCALIB	Low engineering value *	Double
MIDCALIB	Mid engineering value *	Double
HICALIB	High engineering value *	Double

Object	Descriptor	Type
LORESISTANCE	Snapshot low resistance *	Double
MIDRESISTANCE	Snapshot mid resistance *	Double
HIREISTANCE	Snapshot high resistance *	Double
GRADIENT	Calculated gradient *	Double
OFFSET	Calculated offset *	Double
OFFSETADJ	In-use offset adjust *	Double
COEFF1	Calculated low calibration coefficient *	Double
COEFF2	Calculated mid calibration coefficient *	Double
COEFF3	Calculated high calibration coefficient *	Double
ROC	The maximum rate at which the 'INUSE' field can change, per second	Double
SETPOINT	Expected value	Double
DEVIATION	Maximum allowed variation from 'SETPOINT'	Double
AVERAGE	Rolling average of the MEASURED field: $AVERAGE=(AVERAGE+MEASURED)/2$	Double
LASTGOOD	Last MEASURED value	Double
HIHILIM	High – high alarm limit	Double
HILIM	High alarm limit	Double
LOLIM	Low alarm limit	Double
LOLOLIM	Low – low alarm limit	Double
OFFSETENTRY	Operator offset adjust field *	Double
WEIGHTED	Rolling time/flow weighted average	Double
MODETEXT	Mode text	String
CONVTEXT	PRT type	String
ID	For internal use	Double
UNITTEXT	Units associated with the object	String
DESCSHORT	Short descriptor of the object	String

\* Fields used for field calibration

### E.1.30 PRV\_CTL

Object	Descriptor	Type
DESC	Descriptor	String
MODTYP	Prover configuration type. Refer to <i>Prover (P154) Type</i> .	Word
DUALPLSSEL	Select dual pulse channel A/B	Word
PLSSTRSEL	Multiplexer pls selection	Word
CTLINPSEL	Phase locked loop control	Word
SWITCHDELAY	Optional switch delay	Word
SWITCHSEL	Switch sequence selection. Refer to <i>Prover (P154) Switch Sequence Selection</i> .	Word
SWITCH	Switch status	String
SWITCHSTAT	Switch status	Word
STATE	Prove state. Refer to <i>Prover (P154) State</i> .	Word
PLSCNT01	Switch 0 – 1 count data	Double
PLSCNT23	Switch 2 – 3 count data	Double
PLSCNT03	Switch 0 – 3 count data	Double
PLSCNT21	Switch 2 – 1 count data	Double
FLTTM01	Switch 0 – 1 flight time	Double
FLTTM23	Switch 2 – 3 flight time	Double

Object	Descriptor	Type
FLTTM03	Switch 0– 3 flight time	Double
FLTTM21	Switch 2– 1 flight time	Double
DCFLTTM	Dual chronometry flight time	Double

### E.1.31 REP00 – REP39

Object	Descriptor	Type
TIMETEXT	Report time string	String
ID	For internal use	Double
PRINTED	Current printed flag status	Byte
VALID	Valid flag	Byte
FILE	Internal report filename	String
DOCKET	Unique report docket number	String
0	First placement on the top left of the report	Dynamic
N	Last placement on the bottom right of the report	Dynamic

### E.1.32 SECURITY

Object	Descriptor	Type
DESC	Descriptor	String
USERNAME	Username	String
PASSWORD	Password	String

### E.1.33 SYSOBJ

Object	Descriptor	Type
DESC	Descriptor	String

### E.1.34 TASK

Object	Descriptor	Type
DESC	Descriptor	String
USERSRT1	User supplies task argument 1	String
USERSRT2	User supplies task argument 2	String
USERSRT3	User supplies task argument 3	String
USERSRT4	User supplies task argument 4	String
USERSRT5	User supplies task argument 5	String

### E.1.35 TOTTAB

Object	Descriptor	Type
DESC	Descriptor	String
STRCUMINDEX*	Cumulative object index for the stream	Byte
STNCUMINDEX*	Cumulative object index for the station	Byte
XXBATINDEX*	Batch object index for XXX stream	Byte
XXBATINDEX*	Batch object index for XXX station	Byte
STRMAINTINDEX*	Maintenance object for the stream	Byte
STAMMAINTINDEX*	Maintenance object for the station	Byte
STRPRD11INDEX	Basetime 1 period 1 object index for the stream	Byte
STNPRD11INDEX	Basetime 1 period 1 object index for the station	Byte

<b>Object</b>	<b>Descriptor</b>	<b>Type</b>
STRPRD12INDEX	Basetime 1 period 2 object index for the stream	Byte
STNPRD12INDEX	Basetime 1 period 2 object index for the station	Byte
STRPRD13INDEX	Basetime 1 period 3 object index for the stream	Byte
STNPRD13INDEX	Basetime 1 period 3 object index for the station	Byte
STRPRD14INDEX	Basetime 1 period 4 object index for the stream	Byte
STNPRD14INDEX	Basetime 1 period 4 object index for the station	Byte
STRPRD21INDEX	Basetime 2 period 1 object index for the stream	Byte
STNPRD21INDEX	Basetime 2 period 1 object index for the station	Byte
STRPRD22INDEX	Basetime 2 period 2 object index for the stream	Byte
STNPRD22INDEX	Basetime 2 period 2 object index for the station	Byte
STRPRD23INDEX	Basetime 2 period 3 object index for the stream	Byte
STNPRD23INDEX	Basetime 2 period 3 object index for the station	Byte
STRPRD24INDEX	Basetime 2 period 4 object index for the stream	Byte
STNPRD24INDEX	Basetime 2 period 4 object index for the station	Byte
STRPRD31INDEX	Basetime 3 period 1 object index for the stream	Byte
STNPRD31INDEX	Basetime 3 period 1 object index for the station	Byte
STRPRD32INDEX	Basetime 3 period 2 object index for the stream	Byte
STNPRD32INDEX	Basetime 3 period 2 object index for the station	Byte
STRPRD33INDEX	Basetime 3 period 3 object index for the stream	Byte
STNPRD33INDEX	Basetime 3 period 3 object index for the station	Byte
STRPRD34INDEX	Basetime 3 period 4 object index for the stream	Byte
STNPRD34INDEX	Basetime 3 period 4 object index for the station	Byte
DESCSHORT	Descriptor	String

\* Fields used for field calibration

## **E.2 Database Fields**

---

This section provides an alphabetic list of the database fields.

## E.2.1 Alarm Text Tables

Field	Description
Text_1	Alarm text associated with bit 0 of the alarm object
...	
Text_n	Alarm text associated with bit <i>n</i> of the alarm object

## E.2.2 Batching/Totalisation

For keypad integer array BATCH-TOT-CTL.

Field	Description
0	Stop
1	Start
2	Change

## E.2.3 DIGIO Setup Table

Field	Description
0	Sense normal
1	Sense invert
2	Sense pulse on
3	Sense pulse off

## E.2.4 DP Stack Type

Field	Description
0	Single
1	Lo hi
2	Hi hi
3	Lo mid hi
4	Lo hi hi
5	3 Identical

## E.2.5 DP Live/Check Mode Selection

Field	Description
0	Select live
1	Select keypad

## E.2.6 DP Cut Off Mode

Field	Description
0	CATS (Common Area Transmission System). Totalisation does not occur when the measured DP is less than the defined LOLOLIM alarm limit
1	Normal. Totalisation does not occur when the measured DP is less than the CUTOFF value

## E.2.7 Event History Type

Field	Description
0	Default type
1	Double type
2	Multi input type

Field	Description
3	Multi output type
4	Keypad int type
5	Keypad int array type
6	Security type
7	Mode type
8	Text 1 type
9	Text 2 type
10	Text 3 type
11	Message 1 type
12	Message 2 type
13	Message 3 type
14	Reject type
15	Standard type

### E.2.8 HART Poll Format

Field	Description
0	HART poll format CIMAT
1	HART poll format P188

### E.2.9 HART Master Mode

Field	Description
0	Hart primary master
1	Hart secondary master

### E.2.10 I/O (P144) PID Type

Field	Description
0	Pulse
1	DP stack
2	Analog In
3	PRT
4	External pulse
5	Download
10	Pulse square root
11	DP stack square root
12	Analog In (square root)
13	PRT square root
14	External pulse square root
15	Download square root

### E.2.11 Prover (P154) Dual Chronometry Switch Pair

Field	Description
0	Switch 0-1
1	Switch 2-3
2	Switch 0-3
3	Switch 2-1



## E.2.12 Prover (P154) Type

Field	Description
0	Ball/Bi-directional (BIDI) prover
1	Uni-directional prover
2	Compact prover
3	Master meter prover

## E.2.13 Password Tables

Object	Descriptor	Type
DESC	Descriptor	String
USERNAME	Username	String
ALPHAPASSWORD	Password	String
NUMBPASSWORD	Password	String
SEDEV	Security level 1 to 9; 1 being the highest with full read/write access to all parameters.	String

## E.2.14 Truth Tables

Field	Description
Stext1	Text associated with the value field of a KPINT or the text associated the input field of a multi.
Ctext1	Value associated with the output field of a multi.
Sval1	Value enumeration associated with the text
Alm_en1	Enables an alarm on digital I/O
...	
Stext100	Text associated with the value field of a KPINT or the text associated the input field of a multi.
Ctext100	Value associated with the output field of a multi.
Sval100	Value enumeration associated with the text
Alm_en100	Enables an alarm on digital I/O

## E.2.15 Turbine Meter Setup Tables

Field	Description
DESC	Descriptor
TYPE	Type of pulse mode: Single or Dual
Pulse Level	Level at which the pulse is read: Level A or Level B

## E.3 Mode Tables

This section provides an alphabetic list of the database fields you can access through the Report Editor.

### E.3.1 ADC/PRT/HART Modes (MODE TAB PLANTI/O)

Number	Description
0	Measured mode
1	Keypad mode
2	Average mode
3	Last good mode
4	Keypad fail mode

Number	Description
5	Average fail mode
6	Last good fail mode
10	Weighted mode
12	Weighted fail mode

### E.3.2 CALC/ALM Auto Switch Modes

Number	Description
0	CALC1 auto mode
1	CALC2 auto mode
2	CALC3 auto mode
3	CALC4 auto mode
4	Keypad auto mode
5	CALC1 force mode
6	CALC2 force mode
7	CALC3 force mode
8	CALC4 force mode
9	Keypad force mode
10	Keypad shift mode

### E.3.3 CALC/ALM modes (MODE TAB CALC)

Number	Description
0	CALC1 mode
1	CALC2 mode
2	CALC3 mode
3	CALC4 mode
4	Keypad mode
5	Average mode
6	Lastgood
7	Keypad fail mode
8	Average fail mode
9	Lastgood fail mode

### E.3.4 Density Transducer Modes (MODE TAB DENS IP)

Number	Description
0	Keypad mode
1	Dens A mode
2	Dens B mode
3	Average mode
4	Keypad fail mode
10	Weighted mode
11	Weighted fail mode

### E.3.5 DP Modes (MODE TAB DP STACK)

Number	Description
0	Measured mode
1	Keypad fail mode
2	Check mode

### E.3.6 HART Modes (MODE TAB PLANTI/O)

<b>Number</b>	<b>Description</b>
0	Measured mode
1	Keypad mode
2	Average mode
3	Last good mode
4	Keypad fail mode
5	Average fail mode
6	Last good fail mode
11	Weighted mode
12	Weighted fail mode

*[This page is intentionally left blank.]*

## Appendix F – Peer-to-Peer Link Communications

### In This Chapter

F.1	Peer-to-Peer Link Input Functionality.....	F-1
F.2	Enabling the Peer-to-Peer Link.....	F-3
	F.2.1 Configuring the Peer-to-Peer Link.....	F-4
F.3	Critical Data .....	F-9
	F.3.1 Passing an Object from the Duty to the Standby S600+.....	F-14
	F.3.2 Period Object Transfer.....	F-16
F.4	Automatic Failover .....	F-17
	F.4.1 Configuring the S600+ for Automatic Failover.....	F-19
F.5	External / Custom Failover Modes .....	F-25
F.6	Displays.....	F-26
	F.6.1 Control Displays.....	F-26
	F.6.2 Feed-back Displays.....	F-27
	F.6.3 Option Displays .....	F-28
F.7	Downloading and Verifying the Peer to Peer Link.....	F-28

The Peer-to-Peer facility enables you to connect two S600+ flow computers together in an application requiring dual-redundancy. You can select one S600+ to be the main fiscal accounting device (the “duty machine”) and one S600+ to be the backup device (“standby machine”). The failover between duty and standby can be either automatic or manual. The Duty / Standby status (D=Duty, S=Standby) displays in the bottom right-hand corner of the S600+ front panel.

This appendix describes the bi-directional communication link between the duty and standby computers that allows the duty S600+ computer to update the standby S600+ computer with any operator changes made locally at the duty S600+ keypad or via the supervisory.

### F.1 Peer-to-Peer Link Input Functionality

Peer-to-peer link functionality includes:

- Automatic real-time synchronization of constants (such as the keypad K-factor and the orifice diameter) that affect the integrity of the metering system.
- A mechanism to pass operator commands (such as the Batch Start command) to the standby machine in real-time.
- A mechanism to transfer a user defined list of data from the duty machine to the standby machine on a regular basis.

The system uses three processes:

**Event Data** The duty machine uses the event log to identify changes that need transferring to the standby machine. When the duty identifies a change to a specific data point, the duty machine sends the value in the event log to the standby machine.

**Peer Critical** The duty machine transfers a user defined block of objects to the standby machine as part of the main program cycle. It is possible to define separate source and destination objects for each data point. The critical data transfers as one coherent block at least once every 5 seconds.

**Notes:**

- When the S600+ becomes the duty machine, it only starts transferring critical data after the re-synchronisation process completes.
  - You can only configure the peer critical data via the System Editor, and the System Editor is only available after successful completion of the RA901 S600+ Advanced Training course.
- 

**Re-sync at Start-up and Automatic Re-sync**

At start-up, the peer-to-peer link identifies a list of objects that you can change via the front panel / web server. The duty machine sends the latest values from this list to the standby machine. The standby machine compares the latest value from the duty machine and updates values that do not match.

The automatic re-synchronisation process has two operational scenarios:

- When the duty machine first establishes communications with the standby machine, the re-sync takes priority over events / critical data. In this situation, the re-synchronisation process may take approximately a minute to complete (depending on number of streams and such).
- Once the peer-peer link is operational, the re-synchronisation operates in the background by interleaving messages with higher priority event log / peer critical data. In this situation, the re-synchronisation process may take several minutes to complete. You enable this via the RESYNC BGRND option. If the RESYNC BGRND option is not enabled, then the re-synchronisation only occurs when the communications link is (re)-established.

The automatic re-synchronisation list omits items in the filter list. Only constants transfer; commands do not. After all constants transfer, an optional “accept constants” command triggers. This causes the standby machine to trigger any density constants / keypad composition Accept commands.

**Eventing**

The standby machine has the option to event any changes it receives from the duty machine. Note that enabling this option will cause all changes to be evented. Therefore, it is recommended that it is not enabled if peer critical data is required.

**Changes via Modbus**

Changes made via Modbus only transfer to the standby machine if you enable Modbus eventing via the Modbus Editor. Eventing supports all registers.

**Filter List**

The peer-peer link filter identifies a list of changeable objects from the displays and determines whether they should be transferred based on their type and the Peer-to-Peer option selection.

The following items are always excluded from transfer:

- Cold Start / Warm Start / Backup
- System / Stream Maintenance Mode and Maintenance Enable / Disable
- Totals Reset

- PCSetup Link Enable / Disable
- Front Panel Disable / Enable
- Serial Port Settings
- Download Time Command
- Version information

The following items are excluded unless selected in the Peer-to-Peer options (refer to *Section F.2.1 Configuring the Peer-to-Peer Link* for more details):

- PID Commands
- Valve Position
- Station / Stream Batch Commands
- Sampler Commands / Reset Can
- Prove Commands
- Flow Switching Commands
- Peer to Peer Commands / Time Delay

The following items are always transferred:

- Keypad Values
- Modes
- High / Low Alarm limits
- ADC / DAC Scalings
- Proved Data
- Valve Commands
- Accept Commands (Density / Composition / KF/MF) – note that these commands are always transferred as part of the event data but only transferred during re-synchronisation if configured on the peer-to-peer options
- Peer Critical Data

---

## F.2 Enabling the Peer-to-Peer Link

---

You enable the peer-to-peer link with the default settings when you create a new configuration file. To enable a peer-to-peer communications port to configure peer-to-peer communications:

1. Select **Start > All Programs > Config600 3.3 > Config Generator** or **PCSetup** and create a new configuration file.
2. After you have set up the configuration file, select the Peer to Peer Link checkbox in Step 6, Comms Ports.

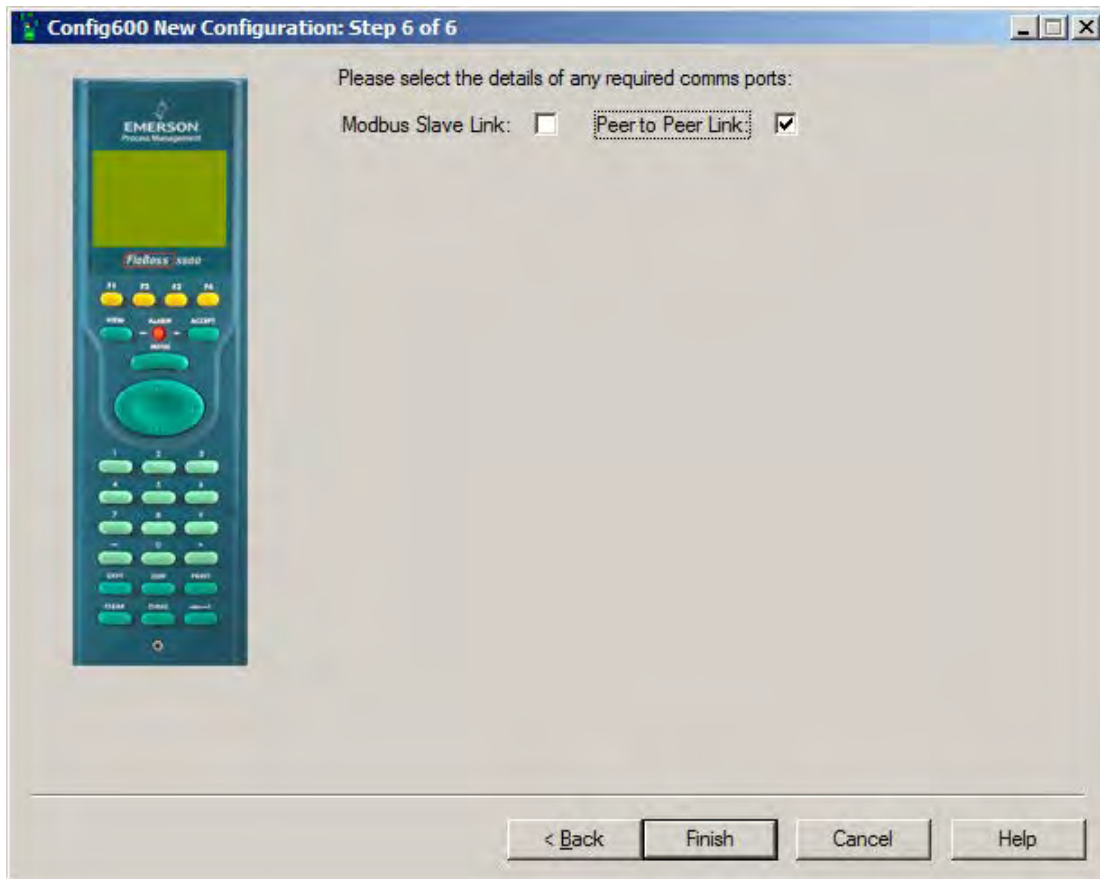

Figure F-1. Select Communications

## F.2.1 Configuring the Peer-to-Peer Link

To configure the peer-to-peer link in PCSetup:

1. Select **I/O Setup > Comms** from the hierarchy menu. The system displays the Communication Task configuration screen.



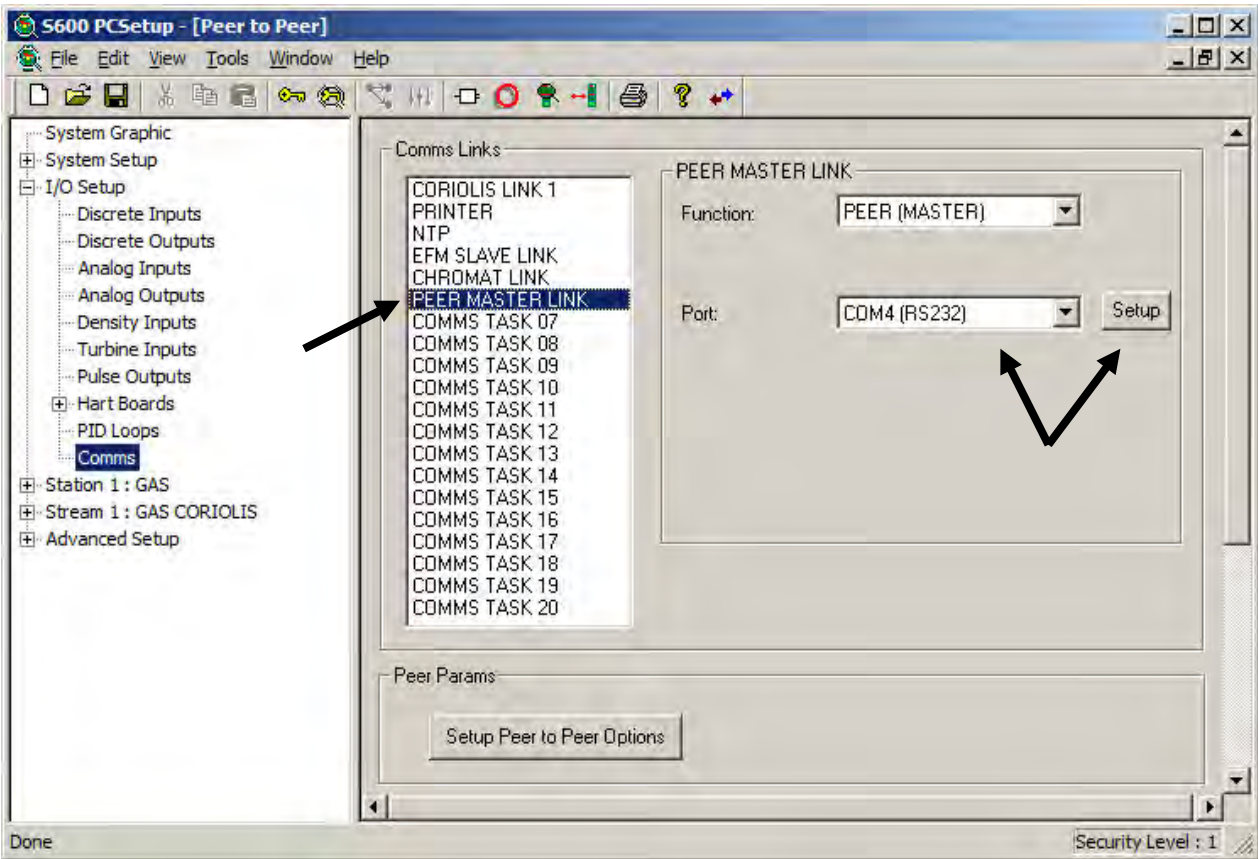

Figure F-2. Comms Link with Peer Master Link and Port Settings

2. Select **PEER MASTER LINK** in the Comms Links field.
3. Select the communication **Port** from the drop-down list box and click **Setup**. A port com setup dialog box displays.

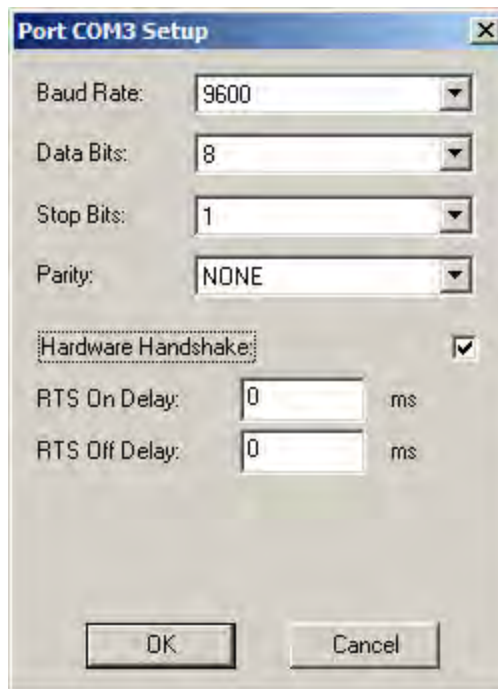

Figure F-3. Port Com Setup Dialog

4. Complete the following fields.

Field	Description
<b>Baud Rate</b>	Indicates the serial transfer rate. Click ▼ to display all values. The <b>default</b> value is <b>9600</b> .
<b>Data Bits</b>	Indicates the number of data bits the port uses. Click ▼ to display all values. The <b>default</b> value is <b>8</b> .
<b>Stop Bits</b>	Indicates the period length. Click ▼ to display all values. The <b>default</b> value is <b>1</b> .
<b>Parity</b>	Indicates the type of parity used to detect data corruption during transmission. Click ▼ to display all values. The <b>default</b> value is <b>None</b> .
<b>Hardware Handshake</b>	Sets RTS/CTS handshaking. When you select this check box, the Ready to Send (RTS) line fluctuates between on and off.
	<b>RTS On Delay</b> Sets, in milliseconds, the amount of time Config600 waits after turning on the ready to send (RTS) signal before beginning transmission. The default is <b>0</b> . You can change this value to optimise communications. The default value should be sufficient for dial-up modems and EIA-232 (RS-232) connections. For older radios, you may need to set this value to 0.2 seconds. For newer radios, 0.02 seconds should be sufficient.
	<b>RTS Off Delay</b> Sets, in milliseconds, the amount of time Config600 waits after transmitting a message before turning off the ready to send (RTS) signal. The default is <b>0</b> . You can change this value to optimise communications. The default value should be sufficient for dial-up modems and EIA-232 (RS-232) connections. For radios, a value of 0.01 may be appropriate. <b>Note:</b> These variables may change based on your situation. These are general values that you need to assess for each circumstance.

5. Click **OK**. The Peer to Peer PCSetup screen displays.
6. Click **Setup Peer to Peer Options**. The Peer Params Setup screen displays.

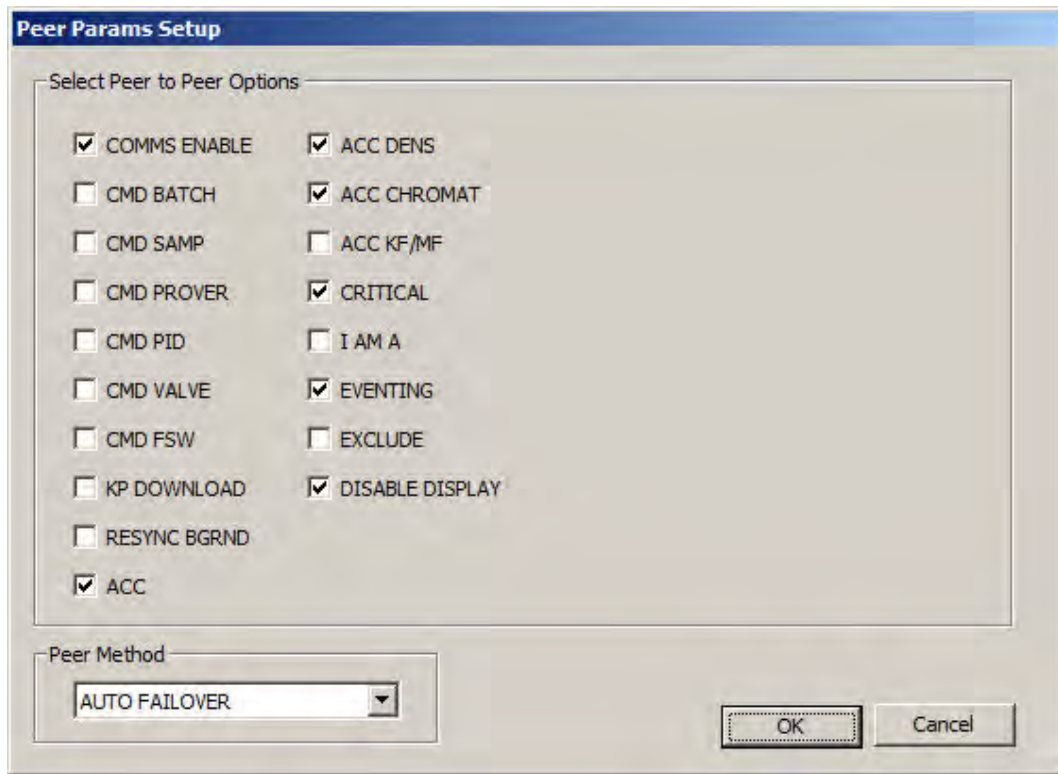

Figure F-4. Peer Params Setup screen

7. Select the appropriate parameters for your peer to peer communications.

Field	Description
<b>COMMS ENABLE</b>	Enables the peer-to-peer communications link.
<b>CMD BATCH</b>	Synchronises batching-related commands If selected, data items transferred are: Station Batch Command Stream Batch Command
<b>CMD SAMP</b>	Synchronises sampling-related commands. If selected, data items transferred are: Sampler Command Reset Can Command <b>Note:</b> <ul style="list-style-type: none"> <li>▪ If checked then the command to start sampling is passed to the Standby machine.</li> <li>▪ If there is only 1 sampler configured this means that both duty and standby will issue grab commands unless there is a hardware interlock in place to stop this.</li> </ul>
<b>CMD PROVER</b>	Synchronises proving-related commands. If selected, data items transferred are: Prove Sequence Command Run Command (Bi-Di / Cprv / MM) Meter Variables (Bi-Di / Cprv / MM)
<b>CMD PID</b>	Synchronises PID-related commands. If selected, data items transferred are: Auto-Manual Command Direction Command

Field	Description
	Tracking Command Manual Position Setpoint
<b>CMD VALVE</b>	Synchronises valve-related commands. If selected, data items transferred are: Valve Position
<b>CMD FSW</b>	Synchronises flow switching-related commands. If selected, data items transferred are: Station Flow Switching Command Stream Flow Switching Command
<b>KP DOWNLOAD</b>	Sets an older peer-to-peer communications protocol. <b>Note: Do not</b> enable this command.
<b>RESYNC BGRND</b>	Perform auto synchronisation in background. Enables auto-resynchronisation of constants (not command) as part of the regular duty cycle. If box un-ticked, re-synchronisation only occurs when the communications are (re)-established between the duty and standby machines.
<b>ACC</b>	Re-synchronisation only. Trigger automatic acceptance of density constants, keypad composition, KF and MF. This over-rides ACC DENS, ACC CHROMAT and ACC KF/MF. If un-ticked no automatic acceptance occurs.
<b>ACC DENS</b>	Re-synchronisation only. Trigger automatic acceptance of density constants during re-synchronisation. If un-ticked no automatic acceptance occurs.
<b>ACC CHROMAT</b>	Re-synchronisation only. Trigger automatic acceptance of keypad chromatograph during re-synchronisation. If un-ticked no automatic acceptance occurs.
<b>ACC KF/MF</b>	Re-synchronisation only. Trigger automatic acceptance of KF and MF during re-synchronisation. If un-ticked no automatic acceptance occurs.
<b>CRITICAL</b>	Critical data transfer enabled – allows transfer of data that is not user enterable (such as FCV Output % to allow bumpless transfer on changeover). Can also be used to exclude items from transfer using the Peer Regular calculation table by configuring the required data item as an input only.
<b>I AM A</b>	Alters the timeout period before designating the standby machine to be duty. If ticked the timeout is 10 seconds otherwise it is 20 seconds.
<b>EVENTING</b>	Enables the eventing of changes of the standby event. <b>Note:</b> This can cause the standby event log to fill up if used in conjunction with the Peer Critical option.
<b>EXCLUDE</b>	Not currently supported. <b>Do not</b> enable this command.
<b>DISABLE DISPLAY</b>	Prevents the operator from making changes on the standby machine by disabling the front panel and webserver.
<b>Peer Method</b>	Indicates how failover from duty machine to standby machine occurs. Click ▼ to display all valid values.
<b>Auto Failover</b>	Sets the duty machine via an internal algorithm. This is the <b>default</b> .
<b>Manual Failover</b>	Sets the duty machine manually through the front panel or webserver.
<b>Digital Input</b>	Sets the duty machine using digital inputs.
<b>Custom</b>	Sets the duty machine using a LogiCalc

Field	Description
	to create the failover logic.

8. Click **OK**. The PCSetup screen displays.
9. Click the **Save** icon on the toolbar to save the changes to the configuration.

### F.3 Critical Data

You can use the peer-to-peer link to update the standby S600+ with critical data that is not operator-enterable, such as:

- FCV output % to allow bumpless transfer if a changeover occurs.
- Prover results (such as meter factor or proved conditions).
- Items specific to individual flow computers; such as ADC calibration points.

Certain data points you must frequently send to the standby machine (such as the position of a PID required for smoother transaction from manual to automatic mode) or information you need to send selectively (such as the ADC Scales, although you may need to send other ADC parameters [like keypad values or modes] separately). If sending data (such as the position of the PID) then it is recommended that EVENTING is disabled on the standby machine.

---

**Note:** Totals and time are not supported.

---

To send critical data:

1. Click **Start > All Programs > Config600 3.3 > System Editor** and open the configuration.
2. Select **System > ALARM**. The Alarm screen displays.
3. Create a new alarm object by scrolling down to the last alarm and right-clicking in the right frame. A pop-up menu displays.

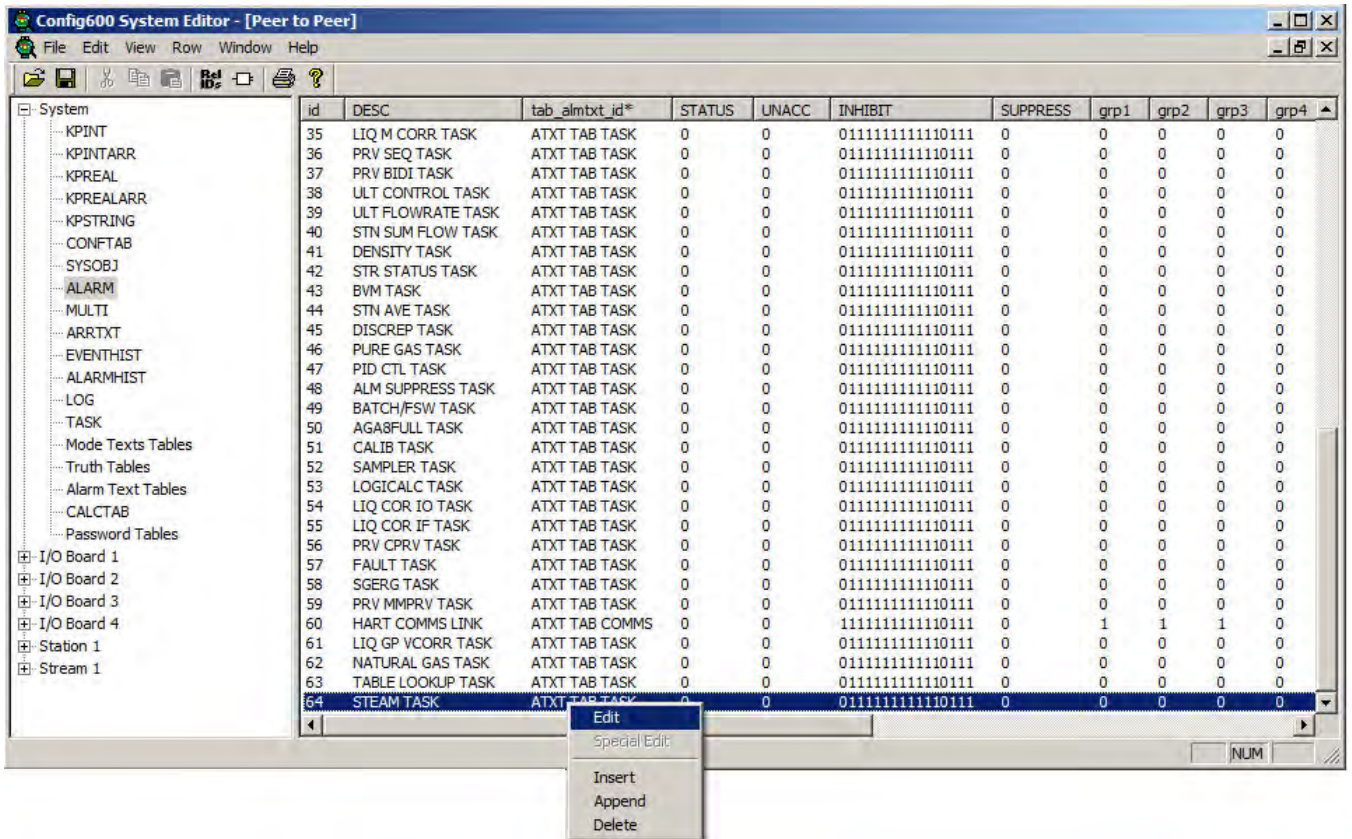

Figure F-5. Pop-up menu on Alarms screen

4. Select **Append** to create a new alarm object. An Edit dialog box displays.
5. Select **DESC** in the Columns pane and enter **PEER CRITICAL** in the Data field.

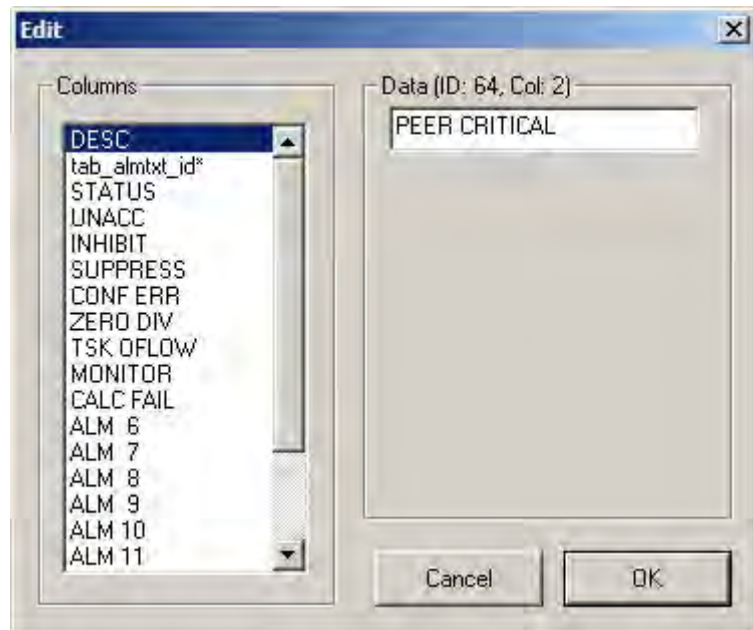

Figure F-6. Edit dialog (1)

6. Select **Columns > DESC** and enter **PEER CRITICAL** in the Data field.

7. Select **Columns** > **tab\_almtxt\_id\*** and enter **23** in the Data field to select the **ATXT TAB CALCS**.

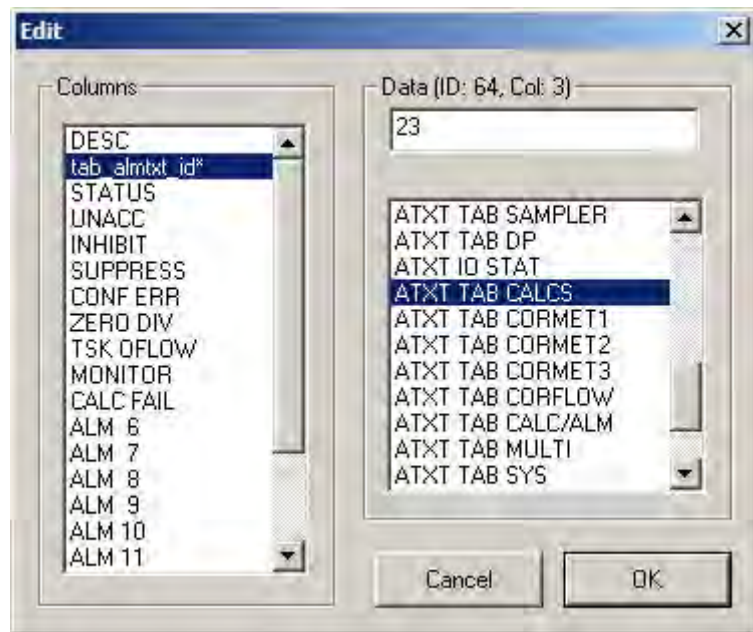

Figure F-7. Edit dialog (2)

8. Click **OK**. The Alarm screen displays. The new alarm object Peer Critical appears at the bottom of the screen's listing.

id	DESC	tab_almtxt_id*	STATUS	UNACC	INHIBIT	SUPPRESS	grp1	grp2	grp3	grp4
36	PRV SEQ TASK	ATXT TAB TASK	0	0	011111111110111	0	0	0	0	0
37	PRV BIDI TASK	ATXT TAB TASK	0	0	011111111110111	0	0	0	0	0
38	ULT CONTROL TASK	ATXT TAB TASK	0	0	011111111110111	0	0	0	0	0
39	ULT FLOWRATE TASK	ATXT TAB TASK	0	0	011111111110111	0	0	0	0	0
40	STN SUM FLOW TASK	ATXT TAB TASK	0	0	011111111110111	0	0	0	0	0
41	DENSITY TASK	ATXT TAB TASK	0	0	011111111110111	0	0	0	0	0
42	STR STATUS TASK	ATXT TAB TASK	0	0	011111111110111	0	0	0	0	0
43	BVM TASK	ATXT TAB TASK	0	0	011111111110111	0	0	0	0	0
44	STN AVE TASK	ATXT TAB TASK	0	0	011111111110111	0	0	0	0	0
45	DISCREP TASK	ATXT TAB TASK	0	0	011111111110111	0	0	0	0	0
46	PURE GAS TASK	ATXT TAB TASK	0	0	011111111110111	0	0	0	0	0
47	PID CTL TASK	ATXT TAB TASK	0	0	011111111110111	0	0	0	0	0
48	ALM SUPPRESS TASK	ATXT TAB TASK	0	0	011111111110111	0	0	0	0	0
49	BATCH/FSW TASK	ATXT TAB TASK	0	0	011111111110111	0	0	0	0	0
50	AGA8FULL TASK	ATXT TAB TASK	0	0	011111111110111	0	0	0	0	0
51	CALIB TASK	ATXT TAB TASK	0	0	011111111110111	0	0	0	0	0
52	SAMPLER TASK	ATXT TAB TASK	0	0	011111111110111	0	0	0	0	0
53	LOGICALC TASK	ATXT TAB TASK	0	0	011111111110111	0	0	0	0	0
54	LIQ COR IO TASK	ATXT TAB TASK	0	0	011111111110111	0	0	0	0	0
55	LIQ COR IF TASK	ATXT TAB TASK	0	0	011111111110111	0	0	0	0	0
56	PRV CPRV TASK	ATXT TAB TASK	0	0	011111111110111	0	0	0	0	0
57	FAULT TASK	ATXT TAB TASK	0	0	011111111110111	0	0	0	0	0
58	SGERG TASK	ATXT TAB TASK	0	0	011111111110111	0	0	0	0	0
59	PRV MIMPRV TASK	ATXT TAB TASK	0	0	011111111110111	0	0	0	0	0
60	HART COMMS LINK	ATXT TAB COMMS	0	0	111111111110111	0	1	1	1	0
61	LIQ GP VCORR TASK	ATXT TAB TASK	0	0	011111111110111	0	0	0	0	0
62	NATURAL GAS TASK	ATXT TAB TASK	0	0	011111111110111	0	0	0	0	0
63	TABLE LOOKUP TASK	ATXT TAB TASK	0	0	011111111110111	0	0	0	0	0
64	STEAM TASK	ATXT TAB TASK	0	0	011111111110111	0	0	0	0	0
65	Peer Critical	ATXT TAB CALCS	0	0	011111111110111	0	0	0	0	0

Figure F-8. Peer Critical Alarm

9. Select **System** > **CALCTAB** to create a new calculations table. The CALCTAB screen displays.

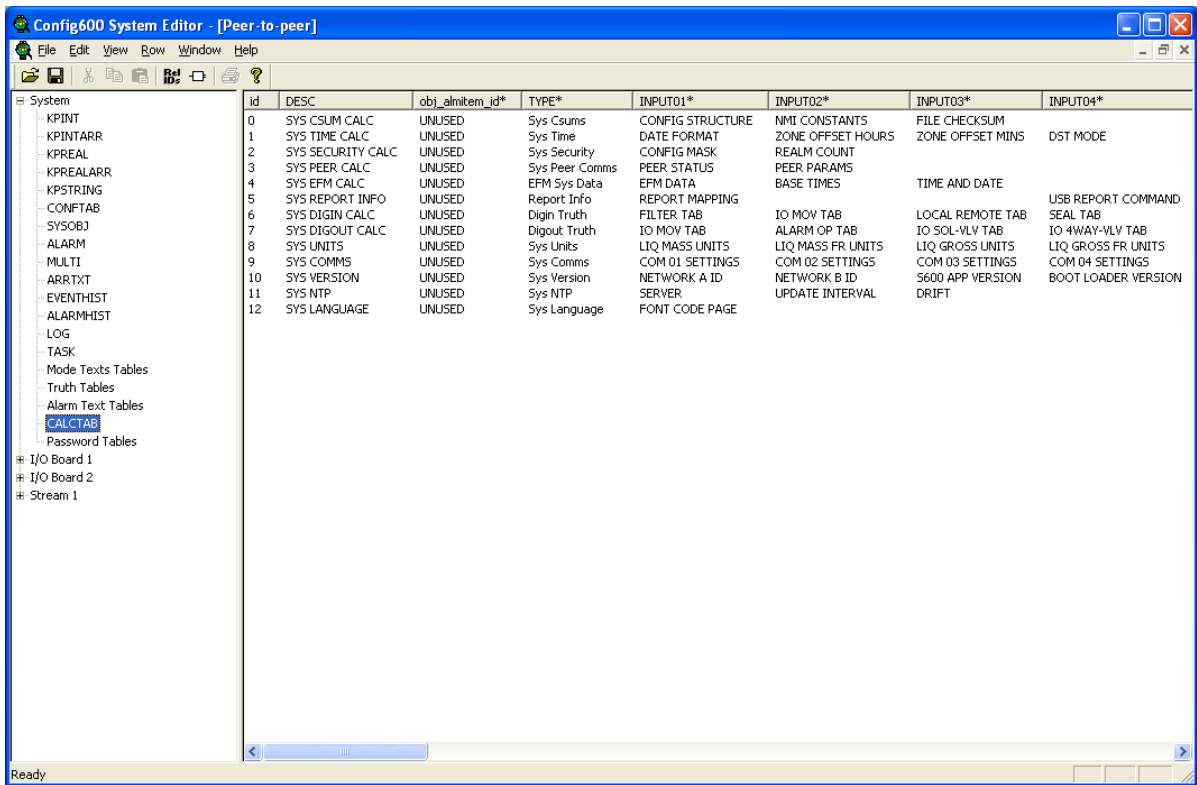

Figure F-9. CALCTAB screen

10. Scroll down to the last calculation and right-click in the right frame. An Edit dialog box displays
11. Select **Append** to create a new calculation object.
12. Select **DESC** in the Columns pane and enter **SYS PEER CRITICAL** in the Data field.

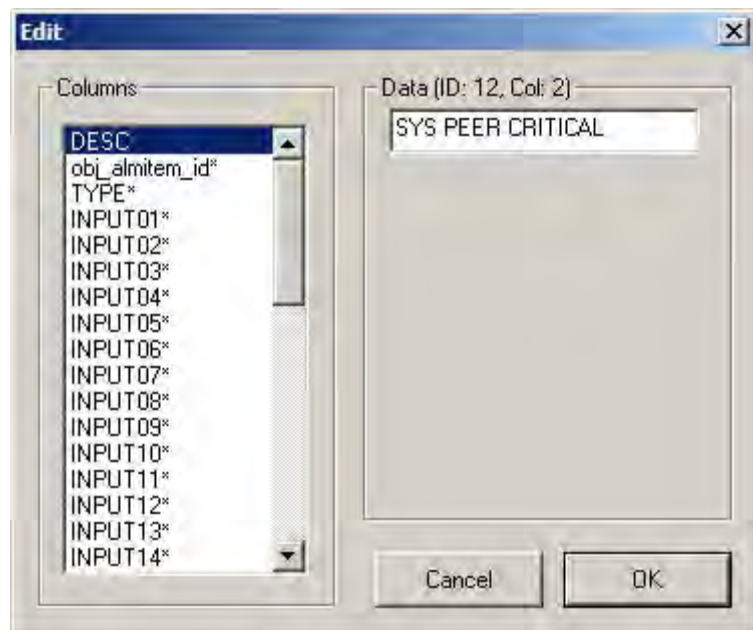

Figure F-10. Edit dialog (1)

13. Select **Columns > obj\_almitem\_id\*** in the Columns pane and select the **PEER CRITICAL** alarm you previously created.



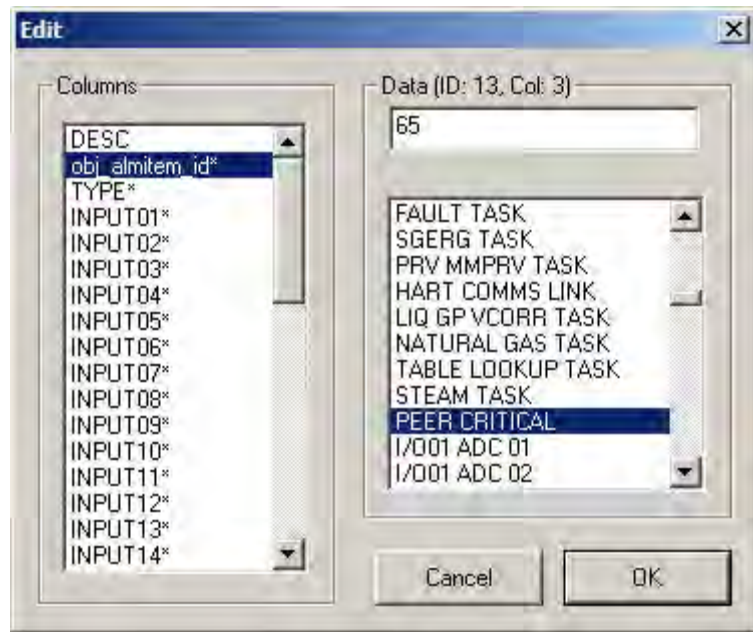

Figure F-11. Edit dialog (2)

14. Select **TYPE\*** in the Columns pane and enter **621** to display the **Peer Regular** Data point.

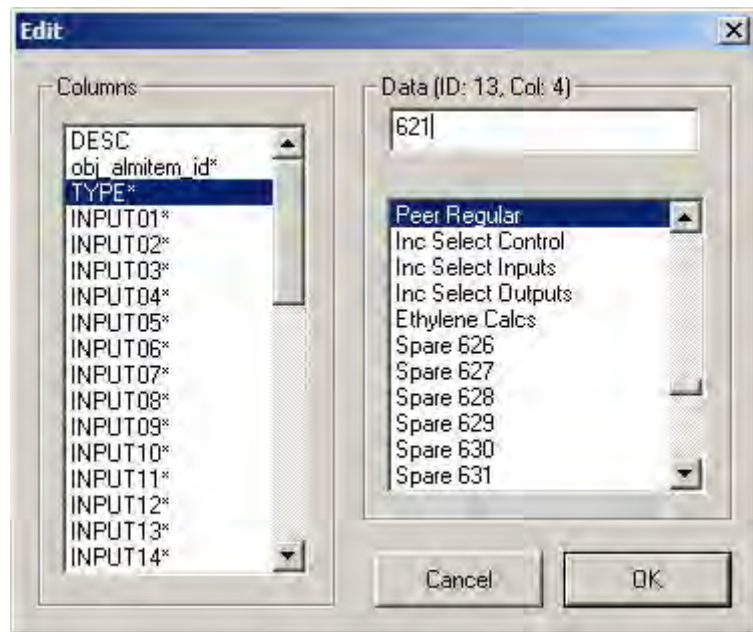

Figure F-12. Edit dialog (3)

15. Click **OK**. The CALCTAB screen displays. Note the new calculation object **SYS PEER CRITICAL** in the **System > Calculation** list.

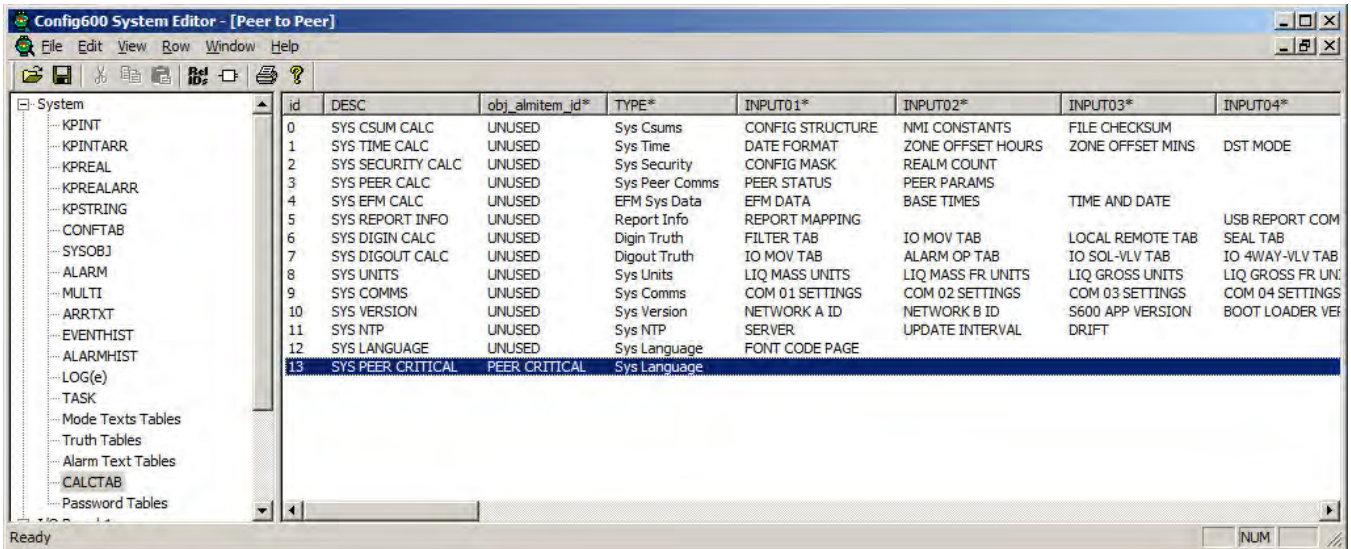



Figure F-13. Peer Critical CALCTAB Object

### F.3.1 Passing an Object from the Duty to the Standby S600+

This example shows how to pass a user-chosen object from the duty S600+ to the standby S600+.

**Note:** Each computer derives its own totals independently. Copying totals from one computer to the other could result in copying erroneous data if the totals someone get corrupted.

1. Double click on the SYS PEER CRITICAL calc table you created in the Critical Data section. The Calc Editor opens.
2. Click  to view the Outputs.
3. Click  on the right side. A new output should appear in the Outputs group with default data.

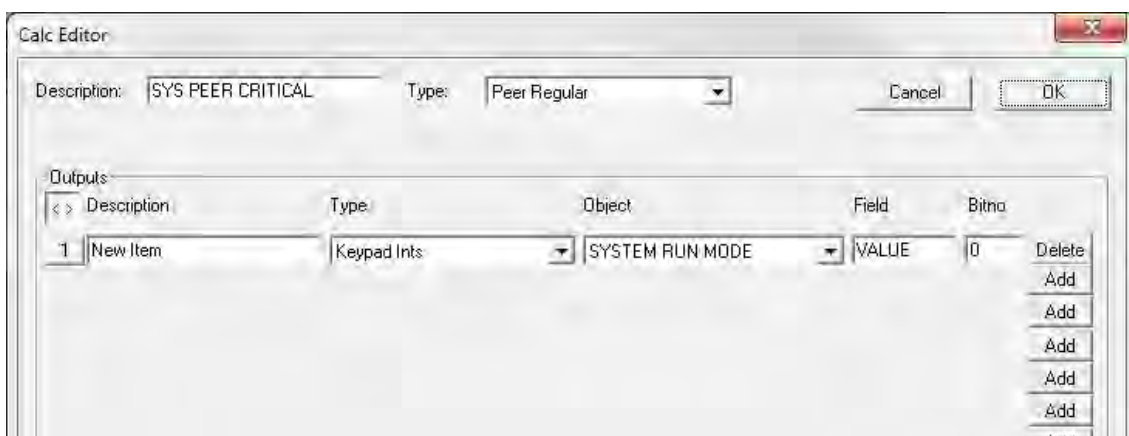

Figure F-14. Calc Editor Outputs

4. Click the numbered button on the left side of the newly created output. The Connect Wizard displays.
5. Select **System > KPINT > SYSTEM RUN MODE > VALUE**. This is the location on the duty S600+ that transfers to the standby S600+.

**Note:** The selected field– and other similar fields – is only an example to illustrate this process.

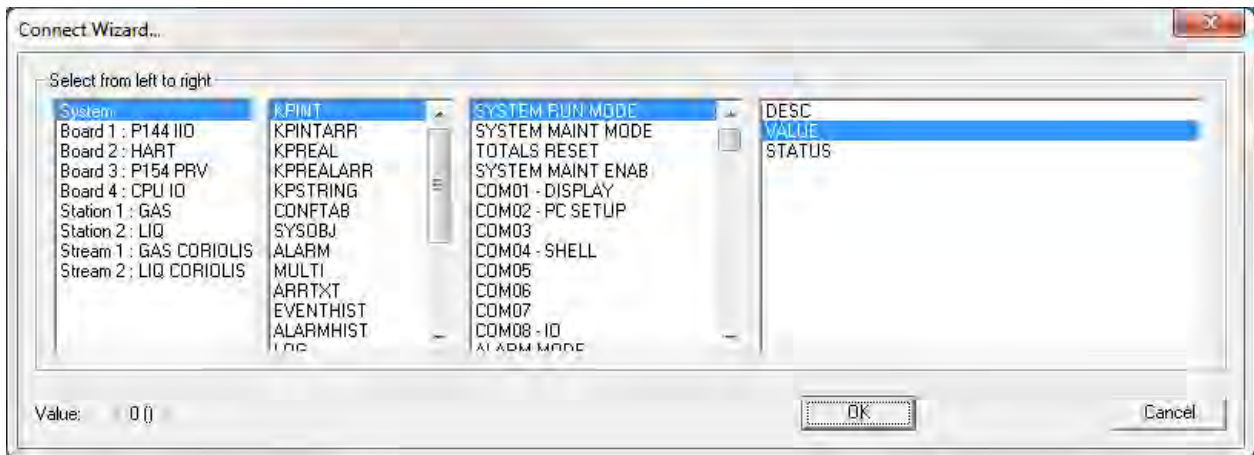

Figure F-15. Connect Wizard – Assigning an object to an output of the SYS PEER CRITICAL Calctab

6. Click **OK** to confirm the changes and close the Connect Wizard.

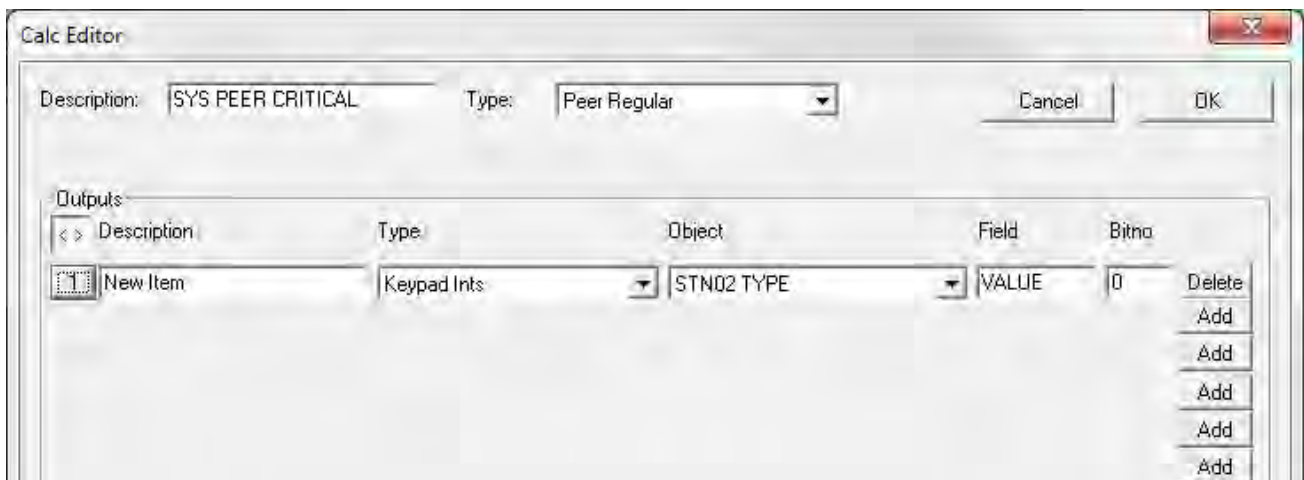



Figure F-16. New Output with Object Assigned

7. Click  to view the Inputs.
8. Click  on the right side. A new input should appear in the Inputs group with default data.
9. Click on the numbered button on the left side of the newly created input. The Connect Wizard displays.

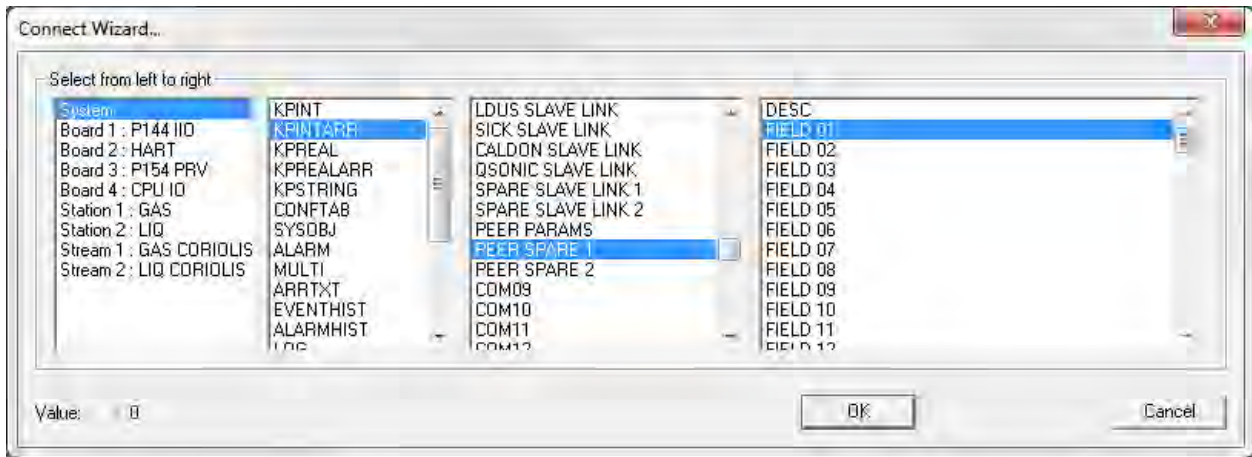

Figure F-17. Connect Wizard – Assigning an object to an input of the SYS PEER CRITICAL calctab

10. Select **System > KPINTARR > PEER SPARE 1 > FIELD 01**. This is the location on the standby S600+ to which data from the Output field transfers.
11. Click **OK** to confirm the changes and **OK** on the Calc Editor to confirm and close it.
12. Open the configuration file in **PCSetup** and enable the **CRITICAL** peer parameter as in *Configuring the Peer to Peer Link*.
13. Add the newly created output to the S600+ displays using the Display Editor to see the values being transferred over the peer to peer communications link.
14. **Save** the configuration file and **upload** it to both S600+ machines.
15. Configure one machine as the duty machine and the other as the standby machine (as described in PCSetup Editor).
16. On the Standby S600+ front panel/webserver, navigate to the location where you created the new display and the object displays with the current second number from the duty S600+.

### F.3.2 Period Object Transfer

You can configure the system to send objects at specific time intervals, in order not to overload the peer to peer link with data that is not of very high importance. Use the System Editor to set these time intervals:

1. Click **Start > All Programs > Config600 3.3 > System Editor** and open the configuration
2. Select the section where the calculation table of type Peer Regular you wish to edit the timing is stored. For example, select **Stream x > CALCTAB** and double-click the calculation table **STR0X PEER PID** to open the Calc Editor

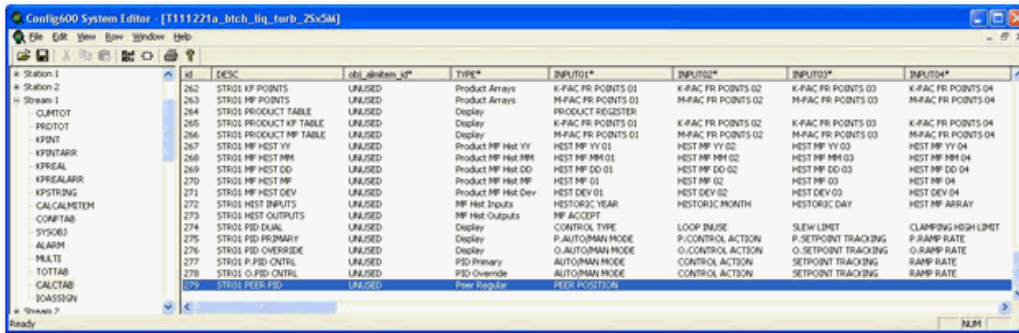



Figure F-18. System Editor

3. Click  to view the Outputs of the calculation table
4. Change the bit number of the output to the desired time interval (in seconds) you want the system to use when sending that object through the peer to peer link. The default value is **30**, which corresponds to 30 seconds
5. Click **OK** to confirm the changes in the Calc Editor
6. Save the configuration file.

## F.4 Automatic Failover

Both the duty S600+ and standby S600+ use digital (status) inputs and outputs in the automatic selection process, as shown in *Figure F-19*. In the event of any computer alarm (i.e. any alarm assigned to alarm group 1), except for those in the following table, the health input-output link changes logic state to invoke a failover. On completion of the failover, the standby S600+ becomes the duty S600+.

**Note:** If you have configured the automatic failover option and it is invoked during a prove, the system transfers the values and control, but the prove run may fail during changeover depending on the prove stage.

Table F-1. Computer Alarms Not Invoking a Failover

ALARM TYPE	ALARM	ALARM GROUP
SYS HOST	COLD ST	ALM GRP 1 COMP
	WARM ST	
	BATT FAIL	
	RESET	
	TOT RESET	
	TOT ROLL OVR	
	TOT ROLL UDR	
	PRINTING ERR	

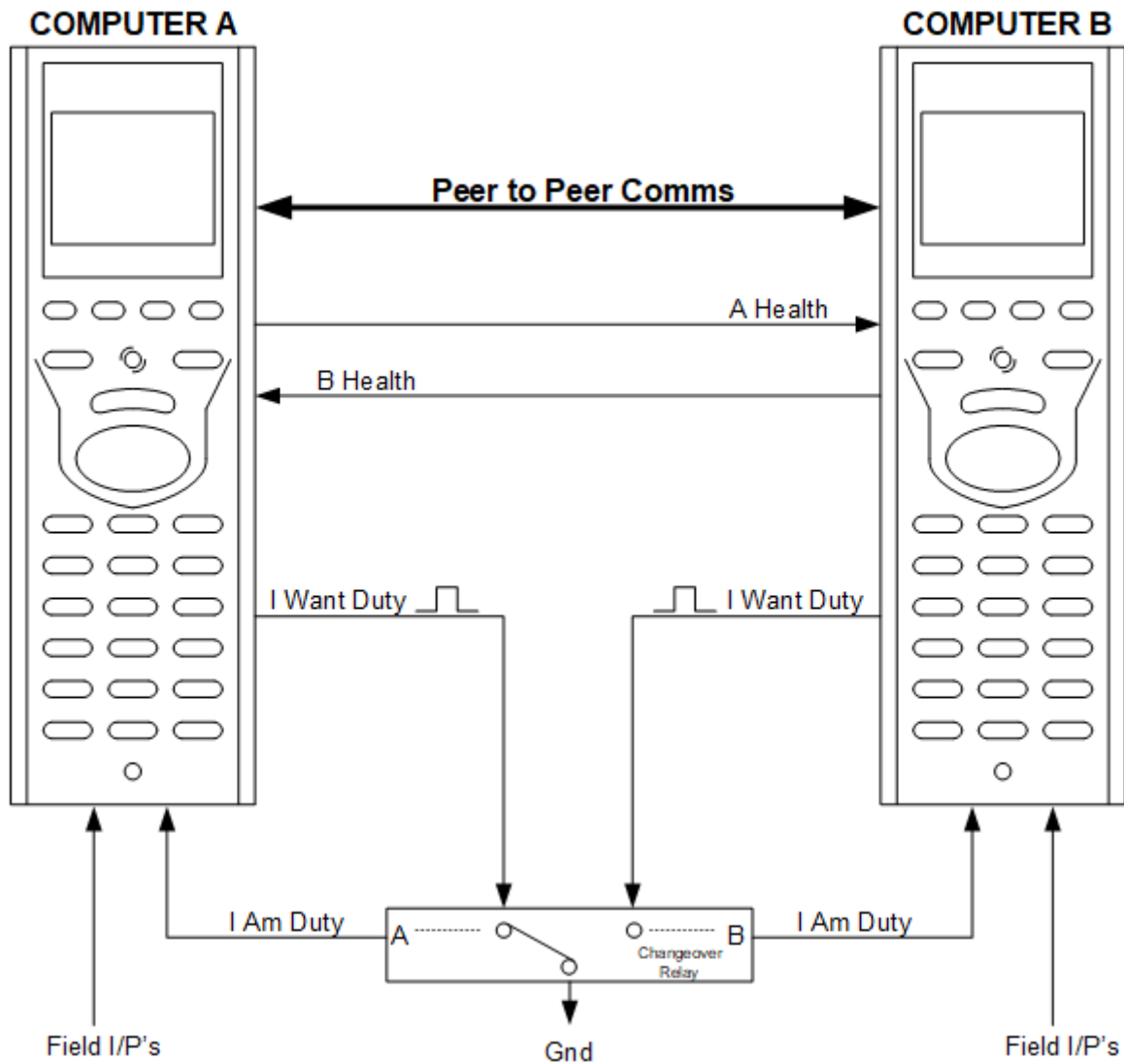

Figure F-19. Status Input and Output Description

Figure F-19 shows two computers designated as A and B. In the event that computer A fails, computer B takes over the duty role (if computer B is itself healthy). Following the changeover from A to B, computer B remains the duty machine until computer A again becomes healthy and is manually reinstated as the duty machine or until computer B fails. If computer B fails and computer A is healthy, then A automatically becomes the duty machine.

Table F-2. Status Input and Output Description

Input/Output Designation	Description
<b>A Health</b>	Indicates the health status for computer A. It is true as long as there are not any group 1 alarms set (apart from those indicated in Table F-1). This signal is continuously monitored by computer B. If the signal goes down, computer B requests to become the duty machine via the I Want Duty output.
<b>B Health</b>	Indicates the health status for computer B. It is true as long as there are not any group 1 alarms set (apart from those indicated in Table F-1). This signal is continuously monitored by computer A. If this signal goes down, computer A requests to become the duty machine via the I Want Duty output.

Input/Output Designation	Description
<b>I Am Duty</b>	Designates which computer is the duty machine. When it is set high, the computer is the duty machine. When set low, the computer is the standby machine. This signal goes high after a Duty request has been made if the relay is working properly
<b>I Want Duty</b>	Whenever a computer needs to become the duty machine, it asserts this signal to make the relay switch and set "I Am Duty" high. The signal is asserted only for a period of time that you configure in the PCSetup Editor.
<b>Peer to Peer Comms</b>	A bi-directional communication link between the A and B computers allows the duty S600+ to update the standby S600+ with any operator changes made locally at the duty S600+ keypad. The Duty/Standby status displays in the bottom right hand corner of the S600+ display (D=Duty and S=Standby). This link also updates all settings and values within the Standby computer following a communications failure of the peer to peer link, such as following computer replacement.
<b>Process Inputs (Field I/Ps)</b>	All field inputs connect in parallel to both S600+ computers allowing each to perform independent processing and totalisation. Discrepancy checking between data reported from the A and B computers is performed elsewhere, such as at a supervisory computer. <b>Note:</b> If you power down one S600+ in an Active Duty-Standby configuration, we recommend either disconnecting socket A (SKT-A) from the I/O module(s) of the offline unit or using external signal isolators when wiring analog inputs.
<b>Control Outputs (Field O/Ps)</b>	All control outputs switch via changeover relay contacts so that only the computer with Duty status has actual control of plant equipment. <b>Note:</b> Control Outputs are only used in particular applications (for example, when the 600+ sends a DAC signal to an FCV.

### F.4.1 Configuring the S600+ for Automatic Failover

This section shows the necessary steps to configure the flow computers to perform Duty/Standby automatic failovers.

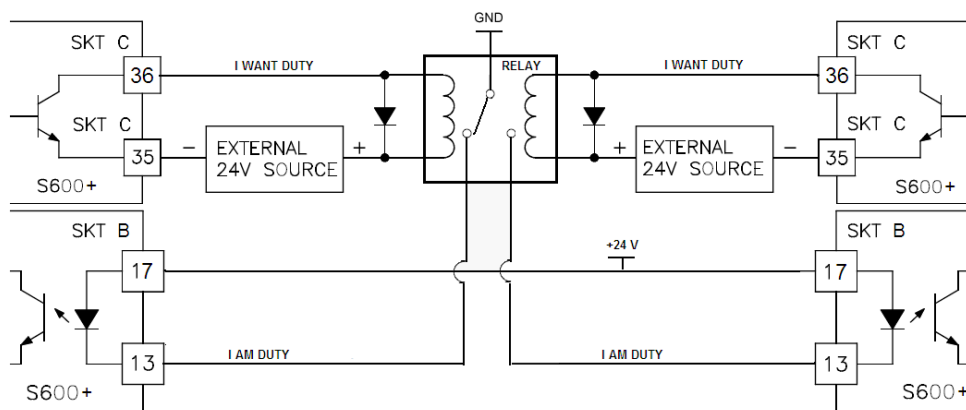

Figure F-20. Duty/Standby Connection Diagram

**Step 1: Wiring Digital Channels** Connect Duty/Standby wiring. The following example uses Digital Output Channel 4 (SKT C: Pin 36) and Return CH1-4 (SKT C: Pin 35) to drive the relay by asserting the 'I Want Duty' signal. Digital Input Channel 1 (SKT B: Pin 13) and Return CH1-4 (SKT B: Pin 17) are used to read the state of the relay which is the 'I Am Duty' signal as in the previous figure. The channels used in the example were chosen arbitrarily.

The relay must be a latching double pole double throw (DPDT) relay for the Duty/Standby logic to work.

Each computer requires a pair of digital channels to connect the health output of one computer to the health input of the other computer. The following example shows how to connect A's health digital output to B's digital input. The same must be done for computer B.

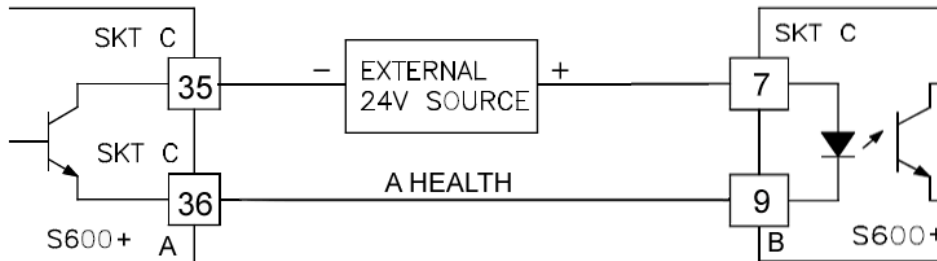

Figure F-21. Connecting A's Health Digital Output to B's Digital Input

**Step 2: PCSetup** After you complete the first step, assign all the digital channels from the previous step to database objects. From PCSetup:

1. Select the **I/O Setup > Discrete Inputs** to channels. The SYS PEER HEALTH and SYS PEER DUTY IO items are currently unassigned.

Refer to Table F-2 and Figure F-19 where:

HEALTH DO = SYS PEER HEALTH output

HEALTH DI = SYS PEER HEALTH input (reported from the other computer)

I WANT DUTY DO = SYS PEER DUTY IO output

I AM DUTY DI = SYS PEER DUTY IO input (the duty / standby status from the relay)

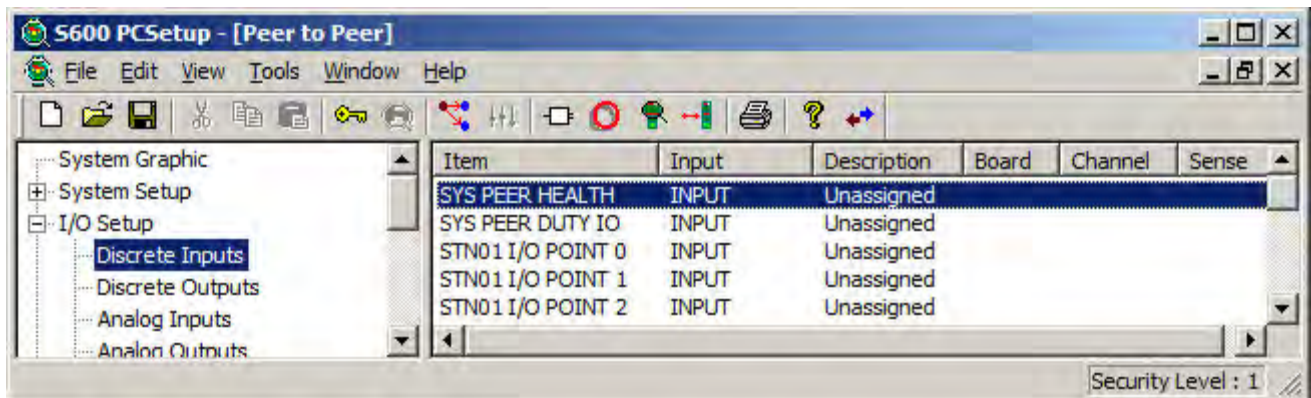

Figure F-22. List of Discrete Inputs before Assignment



2. Double-click **SYS PEER HEALTH** and assign it to **Channel 15** of the P144 I/O Board.

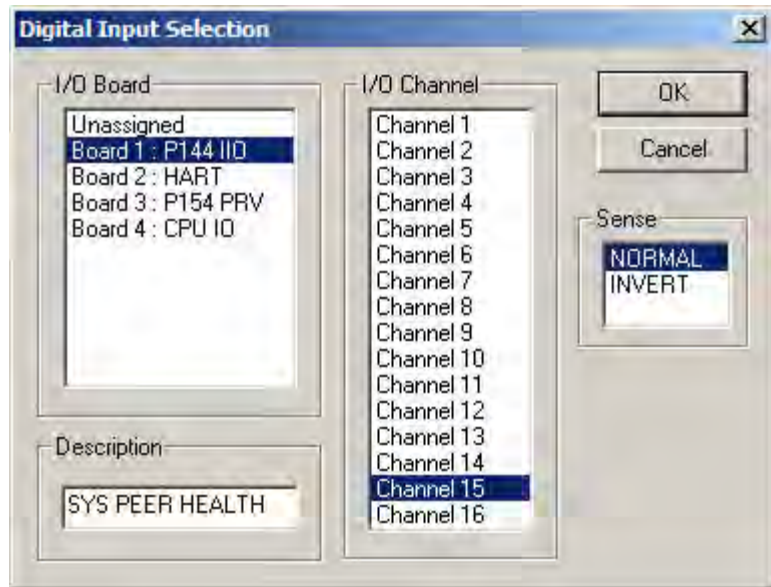

Figure F-23. Digital Input Selection

3. Click **OK**.
4. Double-click **SYS PEER DUTY IO**, assign it to **Channel 12** of the P144 I/O Board, and click **OK**.

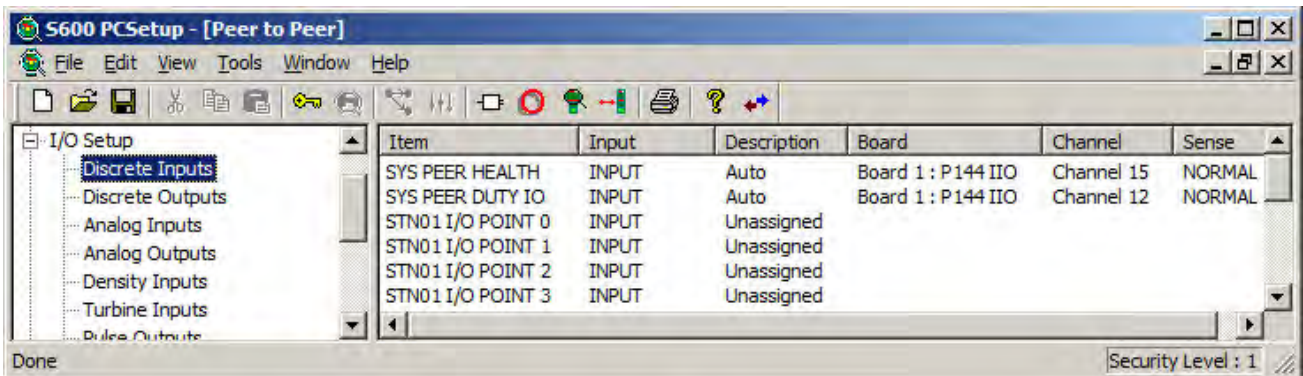

Figure F-24. SYS PEER HEALTH and PEER HEALTH Object (after assignment to Digital Inputs)

5. Select the **I/O Setup > Discrete Outputs** to channels.

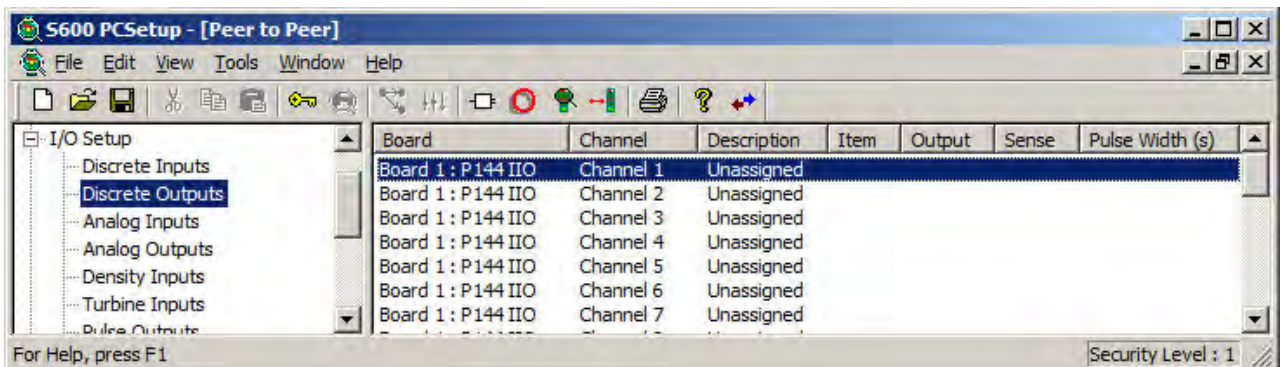

Figure F-25. List of Discrete Outputs before Assignment

**Note:** The SYS PEER DUTY IO output signal is asserted whenever the owning computer requests duty.

6. Double-click **Channel 3** and select **SYS PEER DUTY IO**.

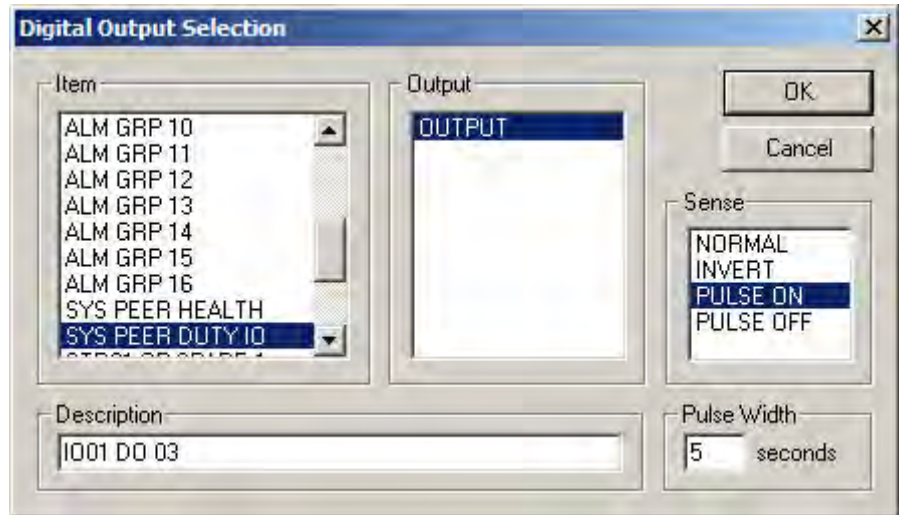

Figure F-26. SYS PEER DUTY IO Digital Output Assignment

7. Select **PULSE ON** in the **Sense** field.
8. Set **Pulse Width** to indicate the number of seconds the SYS PEER DUTY IO signal asserts after receiving a Duty request. The minimum is 5 seconds. If this period of time elapses and the computer has not become the duty machine, the SYS PEER A FAILED alarm triggers.
9. Double-click **Channel 4** and select **SYS PEER HEALTH**. This is the computer's own health output signal and it is also read by the partner computer.

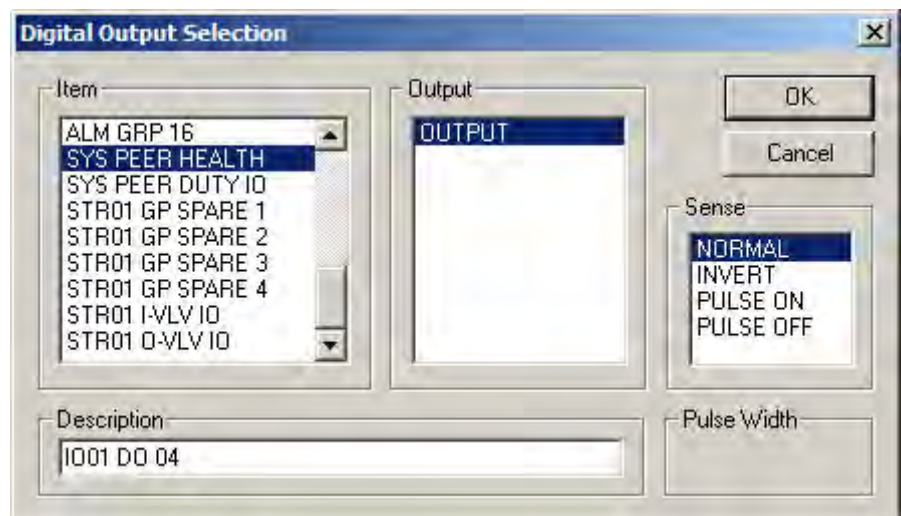

Figure F-27. SYS PEER HEALTH Digital Output Assignment

10. Click **OK**.

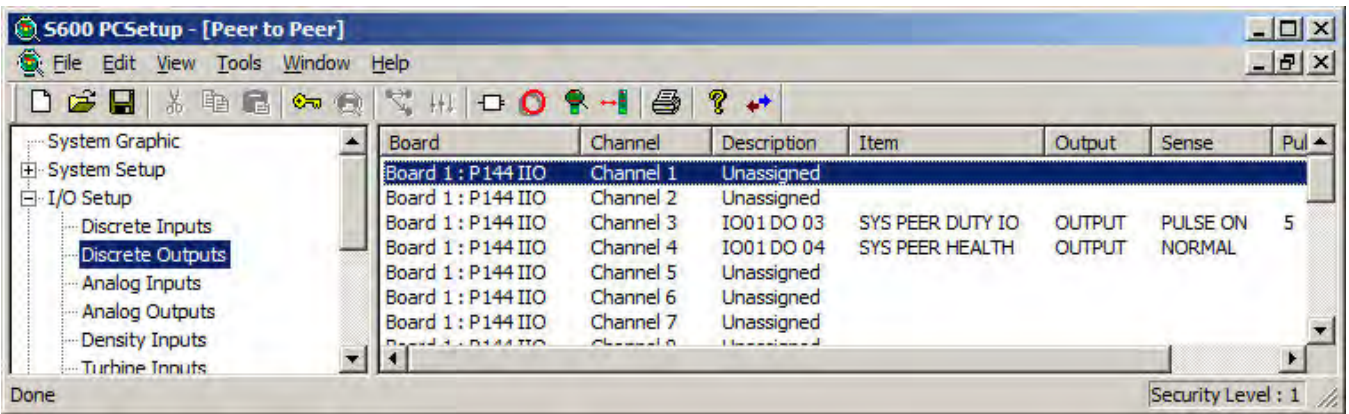

Figure F-28. Channel 3 and Channel 4 (after assignment to SYS PEER DUTY IO and SYS PEER HEALTH)

**Step 3: Activating Automatic Failover** You can activate the Duty/Standby automatic failover logic in either of two ways: through PCSetup or through the front panel or webserver.

**Using PCSetup** You can activate the Duty/Standby automatic failover logic in either of two ways: through PCSetup or through the front panel or webserver.

From PCSetup:

1. Select **I/O Setup > Comms**. The Comms Link screen displays.

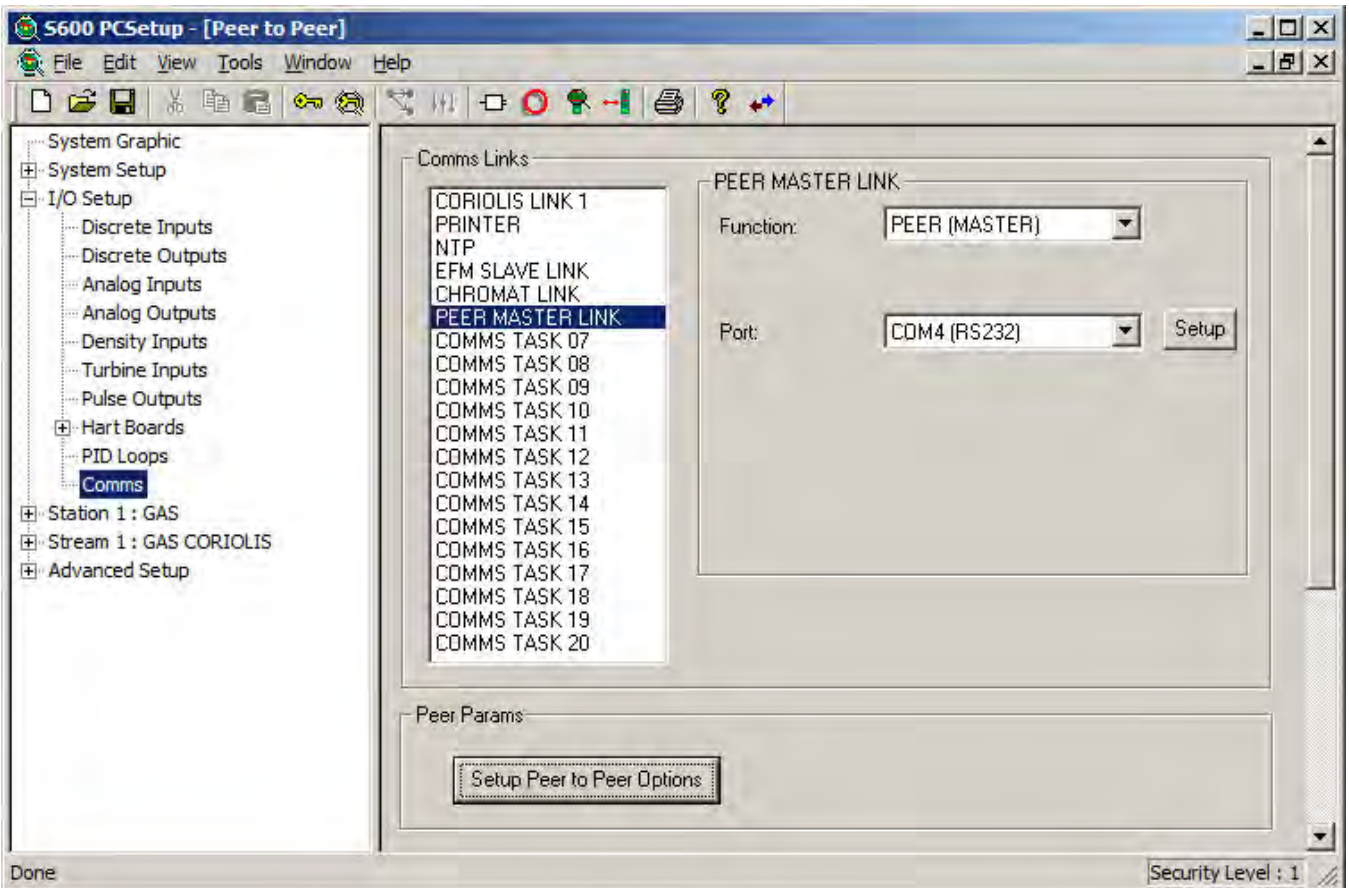

Figure F-29. PCSetup Communications

2. Click **Setup Peer to Peer Options**. The Peer Params Setup screen displays.

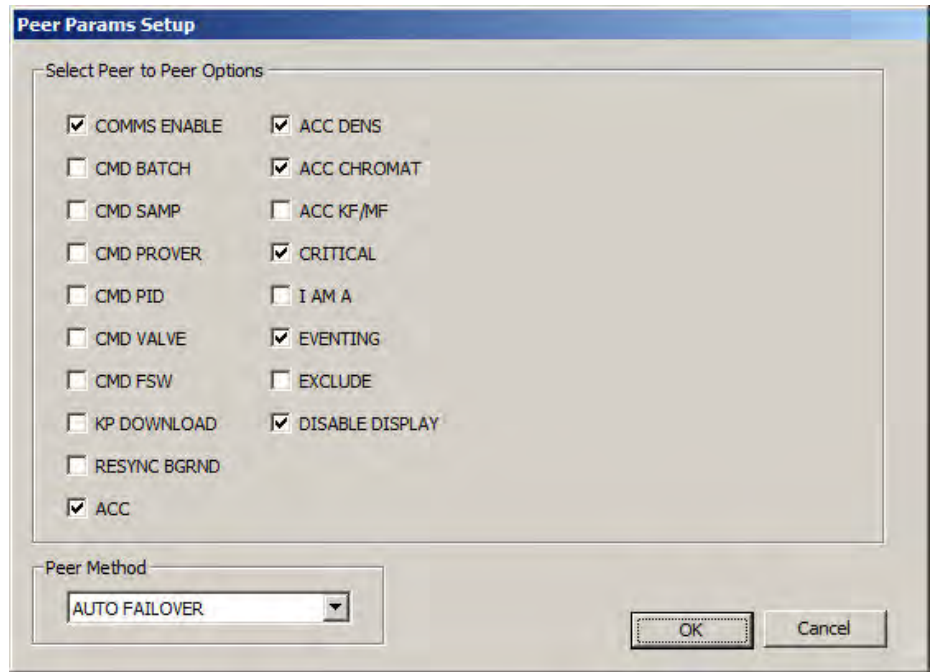

Figure F-30. Peer Params Setup dialog

3. Select **Auto Failover** from the Peer Method field and click **OK**.

**Using Front Panel/Webserver**

From the front panel and the webserver:

1. Select **TECH/ENGINEER > COMMUNICATIONS > ASSIGNMENT > PEER MASTER LINK**. The Peer Duty Logic page displays.

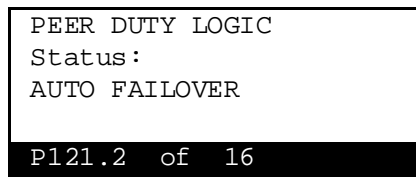

Figure F-31. Peer Duty Logic page

2. Select **AUTO FAILOVER** on the PEER DUTY LOGIC page. This activates the internal HOT BACKUP logic.

**Triggering Duty Status**

The following situations trigger duty status in a computer:

- If one of a pair of computers starts first and is healthy, it becomes the duty machine when it sees its partner as “unhealthy” (that is, turned off).
- If one of the computers has its alarms cleared first while the other one is still unhealthy, then the first computer becomes the duty machine.
- If the computers start exactly at the same time, the one to which the relay points at start-up becomes the duty machine, if it is healthy.
- If the computers’ alarms are cleared exactly at the same time, the one to which the relay points becomes the duty machine.
- If the duty computer becomes unhealthy, it forces the standby computer to become the duty computer, if that machine is healthy.

- If one of the computers is standby and healthy, you can set it to duty status by requesting duty status through the Duty/Standby menus.
- Care should be taken when triggering duty status manually – refer to *Section F.5* below.

## F.5 External / Custom Failover Modes

The S600+ provides three additional modes for setting the duty/standby computer. These modes determine the duty S600+ using an external logic, as opposed to the AUTOMATIC FAILOVER method described in the previous sections, (which sets the duty machine using an internal algorithm).

- **MANUAL FAILOVER**

You manually determine which computer is duty and which is standby by using the front panel or the webserver application. There is no automatic failover. To set the duty S600+, select **TECH/ENGINEER > COMMUNICATIONS > ASSIGNMENT > PEER MASTER LINK** from the front panel and set the status to **DUTY** on the Peer Status page or select Standby to set it to standby status.

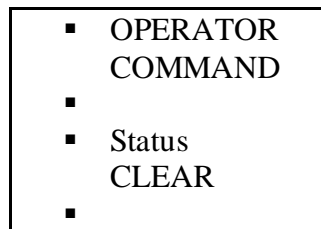

*Figure F-32. Peer Master Link Operator Command Page*

---

### Notes:

- The order in which you perform a manual hand-over is important. First, set the actual duty computer to standby mode. Second, set the other computer to duty mode. If the machine is not healthy, the system ignores this command.
  - You **should not** perform a manual hand-over when the flow computer is proving, batching or sampling. If you need to perform a manual hand-over during one of these processes, you should first abort the process, then perform the manual hand-over, and then restart the process.
- 
- **DIGITAL INPUT**  
This method enables digital inputs to decide the duty or standby status of an S600+. You must connect each input to SYS PEER DUTY IO in PCSetup for each computer as described in the previous sections.
  - **CUSTOM**  
This mode uses a LogiCalc to create a failover logic.

You can access all three modes through PCSetup, the front panel, or the webserver. For example, this procedure uses PCSetup:

1. Select **I/O Setup > Comms** from the hierarchy menu.
2. Select **Peer Master Link** in the Comms Links field.
3. Click **Setup Peer to Peer Options**. The Peer Params Setup screen displays.

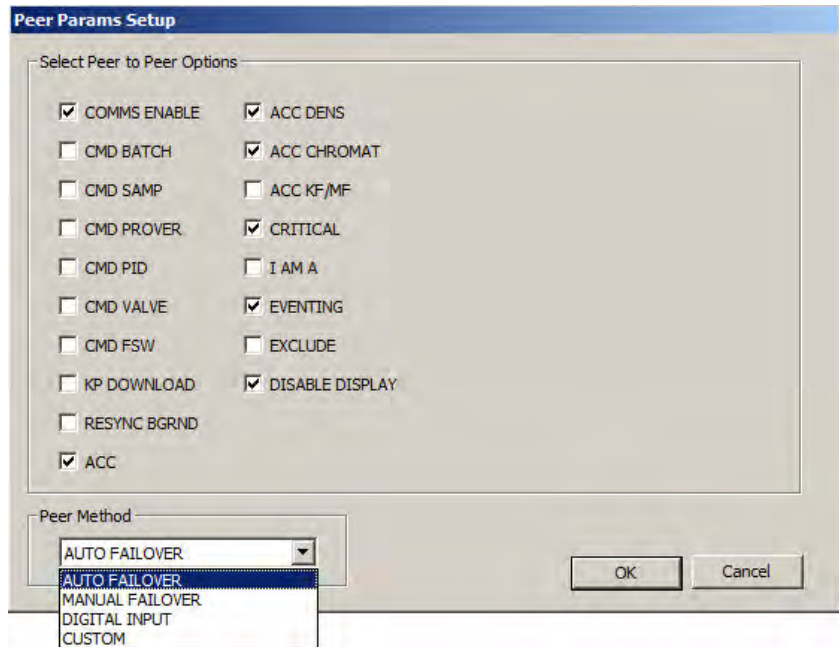

Figure F-33. Peer Params Setup

4. Select **Peer Method** and click **OK**.
5. Click **OK**.

## F.6 Displays

Select **TECH/ENGINEER > COMMUNICATIONS > ASSIGNMENT > PEER MASTER LINK** to view the status or control the Duty/Standby logic. The displays are split in two categories: control and feed-back. You can use the control displays to configure the way the Duty/Standby logic works. The feed-back displays provide useful information about the status of the two computers in the context of the Duty/Standby logic.

### F.6.1 Control Displays

Use the PEER DUTY LOGIC display to select the method the Duty/Standby logic uses. You can select **AUTO FAILOVER**, **MANUAL FAILOVER**, **DIGITAL INPUT**, and **USER**.

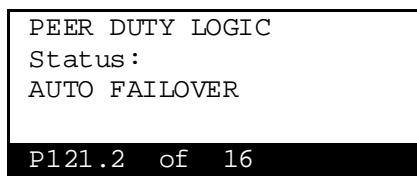

Use the PEER STATUS page to select the status of the peer to peer communications link when the PEER DUTY LOGIC is set to either MANUAL FAILOVER or CUSTOM. Otherwise, it only indicates the status of the peer to peer communications link. The available options are DUTY and STANDBY.

```
PEER STATUS
Status:
DUTY
P121.3 of 16
```

Use the OPERATOR COMMAND to issue a 'Duty' request to the relay. The command can only be SET manually by you. It automatically reverts to CLEAR.

```
OPERATOR COMMAND
Status:
CLEAR
P121.4 of 16
```

## F.6.2 Feed-back Displays

The I AM DUTY page shows the status of the digital input line connected to the SYS PEER DUTY IO object. When the indicated value is 0, the computer status as given by the relay is STANDBY. When the value is 1, the computer status is DUTY.

```
I AM DUTY
Status:
0
P121.5 of 16
```

The MY HEALTH page shows the status of the digital output line connected to the SYS PEER HEALTH object. It indicates the health of the computer that owns the page. If 0, an alarm that is not in the Automatic Failover table triggers and the computer is considered unhealthy. It can only be STANDBY. If 1, the computer is considered healthy and can be either DUTY or STANDBY. This status is also seen by the other peer and based on it, the computer can decide to be either DUTY or STANDBY. This status is mirrored on the PEER HEALTH page of the peer.

```
MY HEALTH
Status:
0
P121.6 of 16
```

The PARTNER HEALTH page shows the status of the digital input line connected to the SYS PEER HEALTH object. It indicates the health of the peer. If 0, an alarm that is not in the Automatic Failover table triggers and the peer is considered unhealthy. It can only be STANDBY. If 1, the peer is considered healthy and can be both DUTY

and STANDBY. This status is mirrored on the MY HEALTH page of the peer.

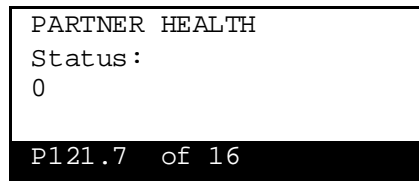

### F.6.3 Option Displays

All of the Peer-to-Peer options listed in section F.2.1 are available under the **TECH/ENGINEER > COMMUNICATIONS > ASSIGNMENT > PEER MASTER LINK** display – following on from the partner health display. These can be used to enable / disable peer-to-peer options during run time.

## F.7 Downloading and Verifying the Peer to Peer Link

---

To download and verify the peer to peer link:

1. Click **Start > All Programs > Config600 3.3 > Config Transfer**.
2. Configure **Config Transfer** communications. Refer to Config Transfer.
3. Select the **Send** tab.
4. Select a configuration that has Peer to Peer Option enabled and click **Send**.
5. Connect the two S600+ flow computers using a communications cable directly between the two devices.
6. Download the file to **both S600+** flow computers.
7. Cold Start **both S600+** flow computers.
8. Configure the **Duty S600+** from the front panel. Select **TECH/ENGINEER > COMMUNICATIONS > ASSIGNMENT > PEER MASTER LINK** and on the **PEER DUTY LOGIC** page, set the Status to **MANUAL FAILOVER**.
9. Navigate to the **PEER STATUS** page and set the **Status** to **DUTY**.
10. Configure the **Standby S600+** from the front panel. Select **TECH/ENGINEER > COMMUNICATIONS > ASSIGNMENT > PEER MASTER LINK** and on the **PEER DUTY LOGIC** page, set the Status to **MANUAL FAILOVER**.
11. Navigate to the **PEER STATUS** page and set the **Status** to **STANDBY**.

---

**Note:** On startup, both S600+ flow computers are in Standby mode and display an "S" at the bottom of the display in the Communications display. A "D" should display after you configure one of the S600+ and if the communication is working.

---



12. On both machines, navigate to **TECH/ENGINEER > COMMUNICATIONS > SERIAL PORTS** and select the **Peer to Peer Link Port** to use. Verify on the second page that the GOOD TX and GOOD RX are increasing. This indicates the machines are communicating.

*[This page is intentionally left blank.]*

## Appendix G – Firewall

### In This Chapter

G.1	Rules File.....	G-1
G.1.1	*Filter Keyword .....	G-2
G.1.2	Default Policies.....	G-2
G.1.3	User Defined Chains.....	G-2
G.2	Adding Rules to the Chain.....	G-3
G.2.1	Applying a Rule to a Range of IPs.....	G-3
G.2.2	Inverting a Rule.....	G-3
G.2.3	After Checking the Rules.....	G-3
G.2.4	Committing the Rules.....	G-3
G.3	Operational Behaviour .....	G-3

The S600+ firewall keeps out unwanted incoming network connections. At its core, the S600+ uses the Linux’s Iptables firewall. You can configure the IP firewall rules in a text file specifying which connections are to be accepted and which to be rejected.

This appendix details **only** the firewall rules for blocking and accepting packets to and from a source. There are many other rules that you can specify. Refer to the Linux Iptables Firewall documentation before making any changes to the configuration text file.

### G.1 Rules File

The configuration file is a plain text file containing the rules by which iptables controls network traffic. You can edit or change the rules using a text editor. Place the file that contains the rules in the “Extras” folder of an S600+ standard configuration. The file name is **exfwall.txt**. The file loads to the S600+ at the same time as the configuration file. The syntax of the rules must be compatible with the one that iptable accepts as valid.

Following is an example exfwall.txt file.

```
#Example of a exfwall.txt file
*filter
:INPUT DROP [0:0]
:FORWARD ACCEPT [0:0]
:OUTPUT DROP [0:0]
:ALLOW_IN - [0:0]
:ALLOW_OUT - [0:0]
-A INPUT -j ALLOW_IN
-A OUTPUT -j ALLOW_OUT
#ALLOW IN
#Allow telnet
-A ALLOW_IN -s 10.97.41.72 -p tcp -m tcp --dport 23 -j ACCEPT
#End of Allow telnet
#Allow Apache
-A ALLOW_IN -s 10.97.41.72 -p tcp -m tcp --dport 80 -j ACCEPT
#End Allow Apache
#Allow Apache Secure
-A ALLOW_IN -s 10.97.41.72 -p tcp -m tcp --dport 443 -j ACCEPT
#End of Allow Apache Secure
```

```
#Allow PC Setup
-A ALLOW_IN -s 10.97.41.72 -p tcp -m tcp --dport 6000 -j ACCEPT
-A ALLOW_IN -s 10.97.41.72 -p tcp -m tcp --dport 6001 -j ACCEPT
-A ALLOW_IN -s 10.97.41.72 -p tcp -m tcp --dport 6002 -j ACCEPT
-A ALLOW_IN -s 10.97.41.72 -p tcp -m tcp --dport 6010 -j ACCEPT
-A ALLOW_IN -s 10.97.41.72 -p tcp -m tcp --dport 6011 -j ACCEPT
-A ALLOW_IN -s 10.97.41.72 -p tcp -m tcp --dport 6012 -j ACCEPT
#End of Allow PC Setup
-A ALLOW_IN -j RETURN
#END ALLOW IN
#ALLOW OUT
-A ALLOW_OUT -d 10.97.41.72 -p tcp -j ACCEPT
-A ALLOW_OUT -j RETURN
#END ALLOW OUT
COMMIT
#End of the exfwall.txt file
```

### G.1.1 \*Filter Keyword

The `*filter` keyword tells the iptables that the following rules are for the filtering table. Within each table, there are chains of specifications and rules.

### G.1.2 Default Policies

The next three lines in the example file:

```
:INPUT DROP [0:0]
:FORWARD ACCEPT [0:0]
:OUTPUT DROP [0:0]
```

define the default policies of the main firewall chains. A chain is a set of rules a data packet must go through. The INPUT chain policy (DROP) applies to all **incoming** packets, the OUTPUT chain policy (DROP) applies to all **outgoing** packets and the FORWARD chain policy (ACCEPT) is for all packets that go through this machine but are not destined for it. A package that is inbound to the INPUT chain is DROPPed (rejected) unless another rule down the chain lets the packet pass through. The square brackets indicate the packet and byte counters. These lines should be left as they are.

### G.1.3 User Defined Chains

The next two lines in the example:

```
:ALLOW_IN - [0:0]
:ALLOW_OUT - [0:0]
```

are user defined chains for the use of clarity; you can call them anything. Both chains contain proprietary rules for the packets that go through.

The next two lines:

```
-A INPUT -j ALLOW_IN
-A OUTPUT -j ALLOW_OUT
```

add the user defined chains to the already existing default chains. A packet that goes through the INPUT chain also goes through (-jump) the ALLOW\_IN chain.

## G.2 Adding Rules to the Chain

---

The following lines define the rules that make up the chains.

```
-A ALLOW_IN -s 10.97.41.72 -p tcp -m tcp --dport 23 -j ACCEPT
```

This line tells iptables to add (-A) a new rule to the ALLOW\_IN chain which catches all packets that have as source (-source) the given IP, as protocol (-protocol) TCP and as port (-dport) 23 and to accept them.

### G.2.1 Applying a Rule to a Range of IPs

To apply a rule to a range of IPs:

```
-A ALLOW_IN -p tcp -m iprange --src-range 192.168.1.13-192.168.2.19 -j  
ACCEPT
```

### G.2.2 Inverting a Rule

To invert the rule, add an “!”.

```
-A ALLOW_IN -p tcp -m iprange ! --src-range 192.168.1.13-192.168.2.19 -j  
ACCEPT
```

### G.2.3 After Checking the Rules

The line:

```
-A ALLOW_IN -j RETURN
```

adds a rule that tells iptables what to do after checking all the rules defined above for this chain. It returns to the parent chain, in this case INPUT.

### G.2.4 Committing the Rules

The COMMIT keyword tells iptables to commit all the rules specified above it to the kernel.

## G.3 Operational Behaviour

---

- The S600+ firewall is **off** (all connections allowed regardless of the rules in the exfwall.txt file) when the S600+ is in the Cold Start menu.
- The S600+ firewall is **on** (connections filter according to the rules file) as soon as you leave the Cold Start menu and the unit starts metering.

*[This page is intentionally left blank.]*

## Appendix H – CFX Reporting

### In This Chapter

---

H.1	Adding CFX Report Functionality to a Configuration File.....	H-1
H.2	Enabling CFX at the Stream Level .....	H-3
H.3	Changing CFX Settings from Config600.....	H-4
H.4	Regenerating the CFX Report Template .....	H-5
H.5	Generating a CFX Report from the Web Browser .....	H-5
H.6	Understanding the CFX File Structure.....	H-8

---

This appendix describes how to configure and produce reports that use the Common File eXchange (CFX) file format from Flow-Cal, Inc.

**Licences** This feature requires that you have a license on your S600+. Without a license, you cannot generate CFX files. Contact Technical Support for further information on purchasing a license key and activating CFX functionality.

---

#### Notes:

- If you need the capability to extract reports for Flow-Cal server access, contact Technical Support.
  - When you generate CFX report files from an S600+, ensure that the S600+ supports no more than eight (8) meter runs. **Do not** create a 9- or 10-meter run application that also creates CFX files.
- 

### H.1 Adding CFX Report Functionality to a Configuration File

---

To add CFX reports to your configuration:

1. Open the Config Generator.
2. Follow the usual steps to add I/O modules and stations.

---

**Note:** When you choose a meter type, note that the system supports CFX only for **ultrasonic gas** meters and for **ultrasonic, turbine, and Coriolis liquid** meters.

---

3. At the Streams configuration screen, press **Options**.
  - For a **liquid** stream, the following window displays:

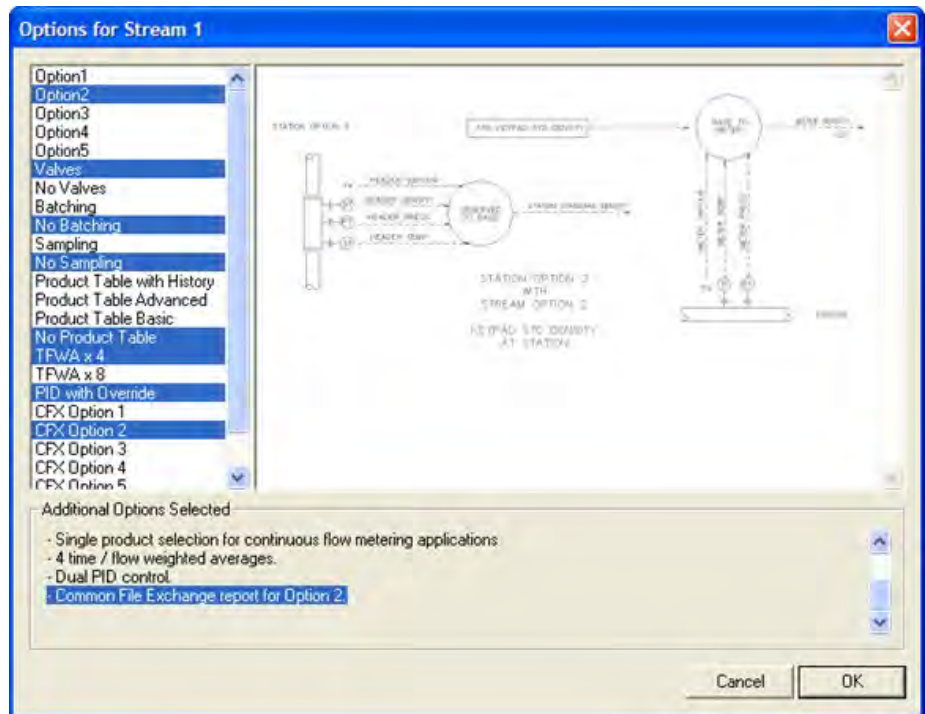

Choose the appropriate option. The CFX option you select must match the density option. In the example above, Option2 has been selected for density, so you must select CFX Option 2 to enable CFX reports on this stream.

- For a **gas** stream, the following window displays:

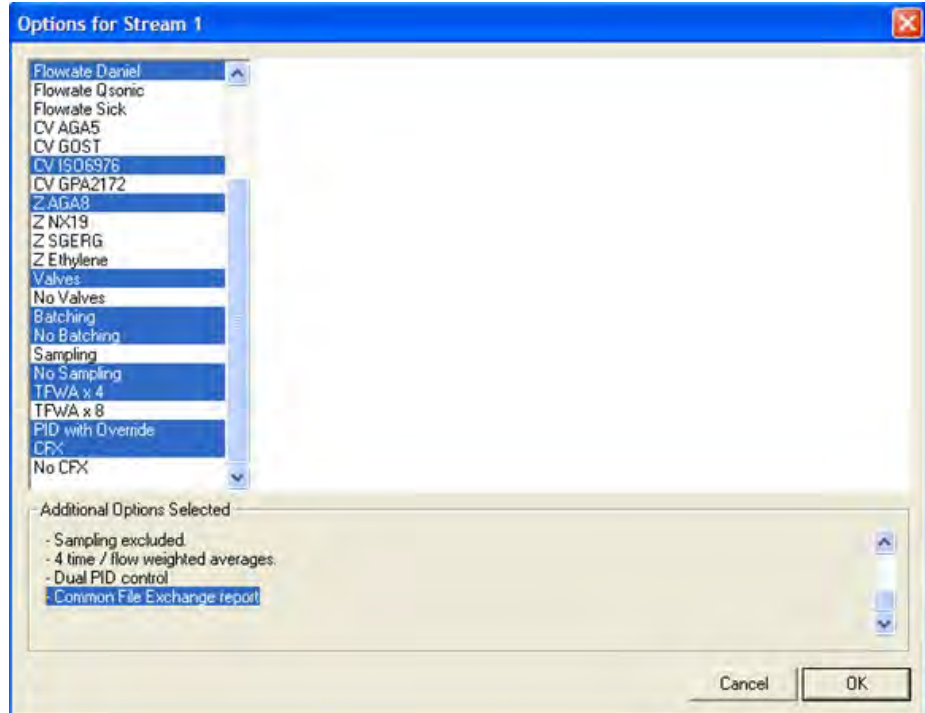

Choose the appropriate option. Choose **CFX** to enable CFX reports on this stream.

4. Complete the process of generating the configuration.



## H.2 Enabling CFX at the Stream Level

To enable CFX at the stream level:

1. Open the generated configuration in PCSetup. In the left pane, select **Reports** under **System Setup**. Using the **Base Time Reports** frame, select the period for the CFX report.

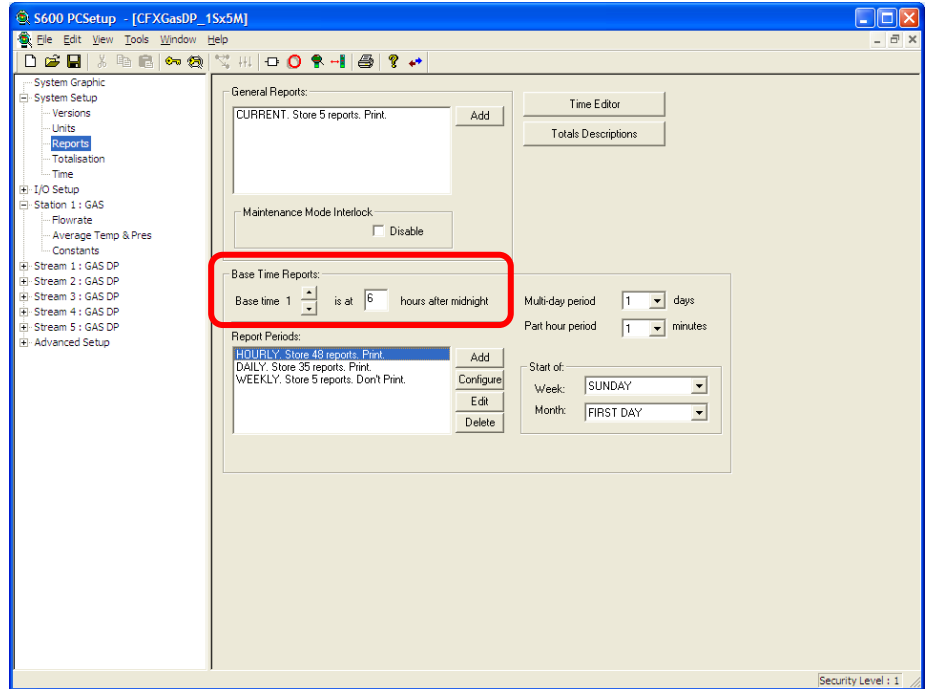

2. Click **Add** or **Configure**. The Archive Configuration dialog displays, showing a list of available streams with CFX file capabilities.

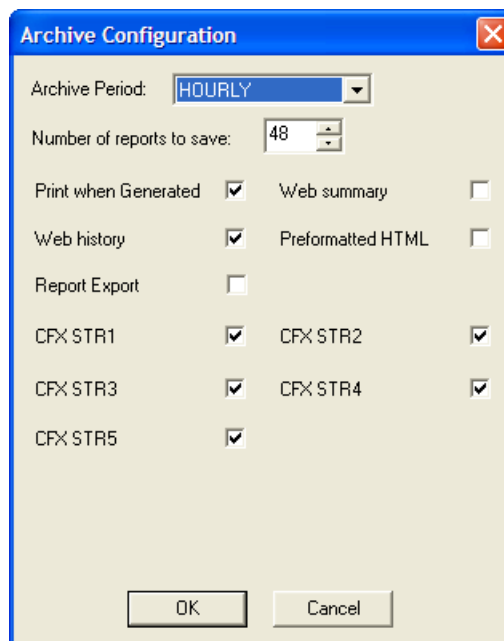

3. Select the appropriate checkboxes to enable or disable CFX generation for a specific stream.

**Note:** The dialog also displays standard S600+ period reports for the selected period. The **Number of reports to save** field refers to **both** standard S600+ reports and CFX reports. If you select **48**, the program generates a total of 48 reports (standard reports **and** CFX reports). Once the system saves this number of reports, it overwrites older reports. Plan the number of reports you want to save accordingly.

At any time you can edit or delete the CFX reports in your configuration file. Click **Configure** on the System Setup screen to display the Archive Configuration dialog. If you **delete** a report period from the configuration file, you also delete any reports (both standard S600+ and CFX) for that period.

### H.3 Changing CFX Settings from Config600

Using a Config600 menu, you can change some of the data the system exports to a CFX report. This menu is available for each stream you defined to generate the CFX report (that is, you selected the CFX option for that stream in the Config Generator, discussed in *Adding CFX Report Functionality to a Configuration File*).

The following example shows the CFX menu for stream 1, which is a liquid turbine stream:

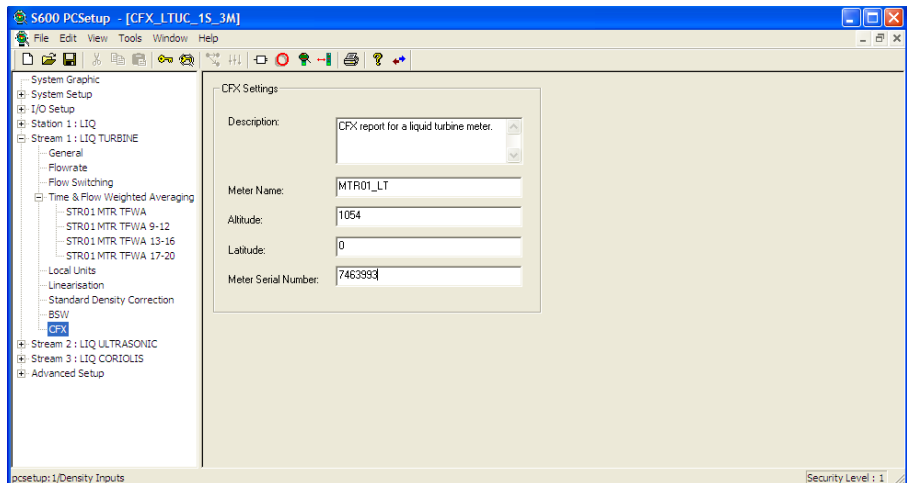

When you select **CFX**, the system displays the CFX Settings screen, which you use to change the following parameters:

Field	Description
<b>Description</b>	Provides a description (with a maximum of 77 alphanumeric characters) of the CFX report.
<b>Meter Name</b>	Indicates the meter generating the CFX report.
<b>Altitude</b>	Indicates the altitude of the meter generating the CFX report.
<b>Latitude</b>	Indicates the latitude of the meter generating the CFX report.
<b>Meter Serial Number</b>	Indicates the serial number of the meter generating the CFX report.

## H.4 Regenerating the CFX Report Template

---

Each time you change the CFX calculation tables (by removing, adding, or changing objects or object types), you must regenerate the CFX template files. After you finish editing the configuration file (using either System Editor or PCSetup), you should regenerate the CFX report file template.

To regenerate the CFX reports:

1. Open the configuration file (using either PCSetup or the System Editor).
2. Select **File > Regenerate**. The system displays the Display and Modbus Regeneration dialog.

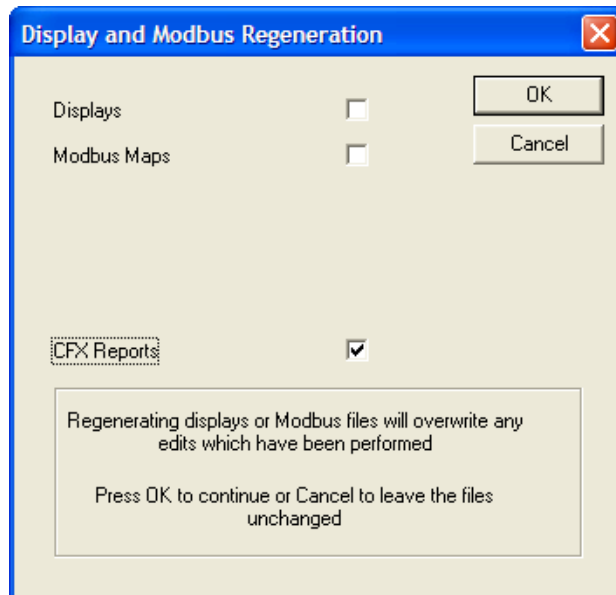

3. Select the **CFX Reports** checkbox.
4. Click **OK**.

## H.5 Generating a CFX Report from the Web Browser

---

To generate a CFX report from the web browser:

1. Start a new browser session and select the Reports options.

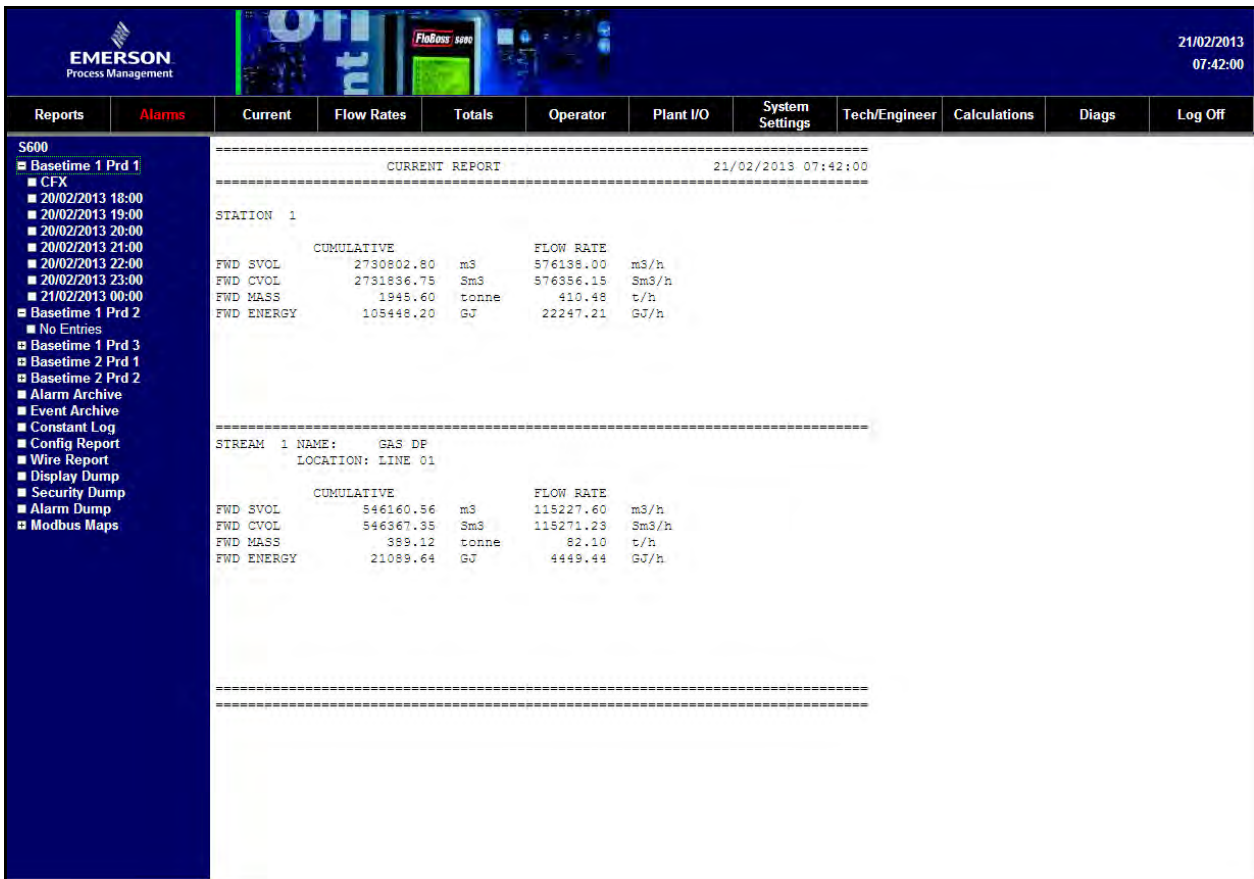

2. Select the CFX option. The CFX control page displays, showing the available controls for any stream for which you have set the CFX option in PCSetup.

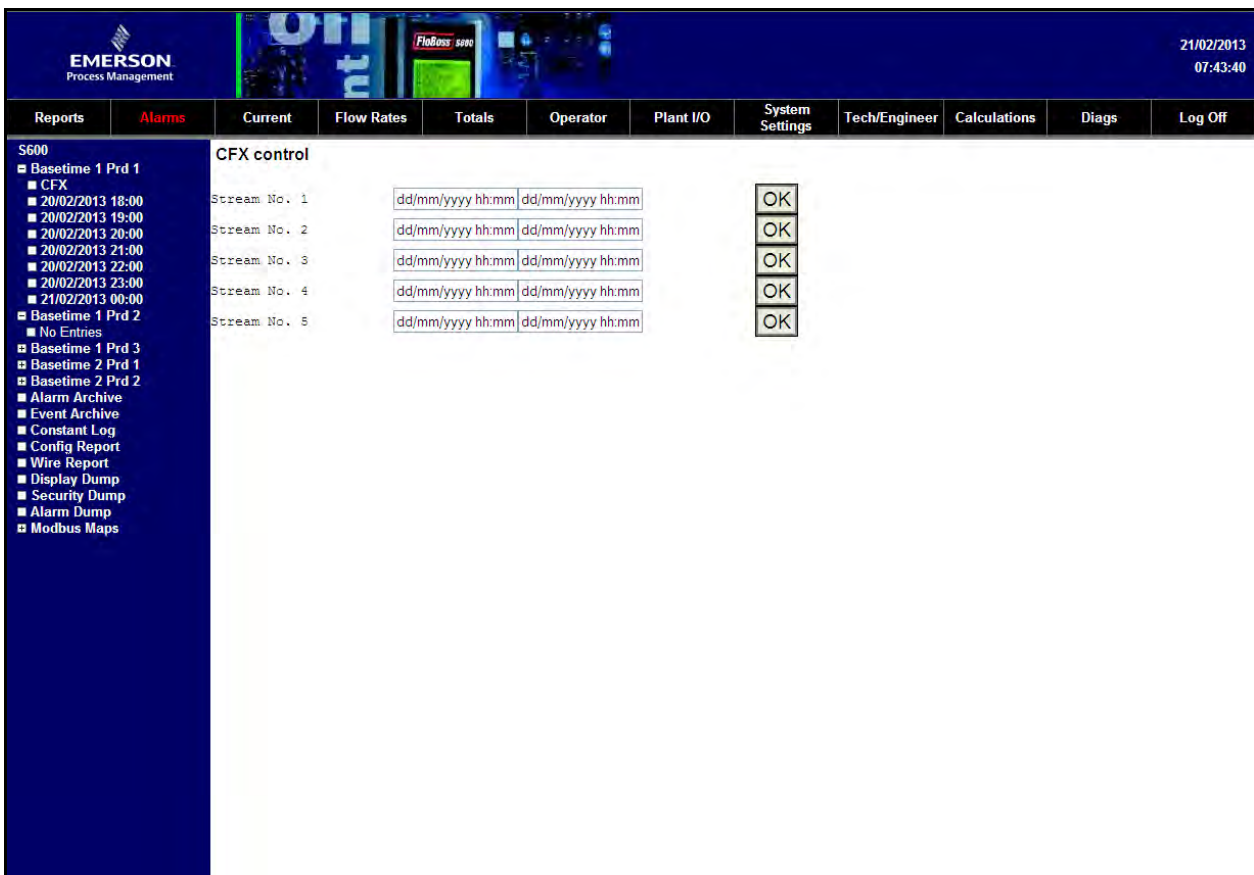

- To generate a CFX report for a stream, enter the time range in the corresponding input field. The first field indicates the report's start time; the second field indicates the report's end time. The system exports to the CFX report any historical items, alarms, and events specific to this stream that were generated during the time range you have selected. When completed, your screen might look like this for stream 1:

Stream No. 1	20/02/2013 18:00	20/02/2013 21:00	OK
Stream No. 2	dd/mm/yyyy hh:mm	dd/mm/yyyy hh:mm	OK
Stream No. 3	dd/mm/yyyy hh:mm	dd/mm/yyyy hh:mm	OK
Stream No. 4	dd/mm/yyyy hh:mm	dd/mm/yyyy hh:mm	OK
Stream No. 5	dd/mm/yyyy hh:mm	dd/mm/yyyy hh:mm	OK

**CFX Files and Time Stamps**

The time stamp for a generated CFX file is typically several seconds **after** the period closes. For example, a CFX file that contains historical flow data, alarms, and events for the hour between 12:00 and 13:00 is generated and given a time stamp of approximately 5 seconds after 13:00 (that is, 13:00:05). To download the CFX file that contains data between 12:00 and 13:00, you need to enter **13:00** for the start time and **13:01** for the time stamp.

- Click **OK** to generate the CFX report for the selected stream. A File Download dialog displays.

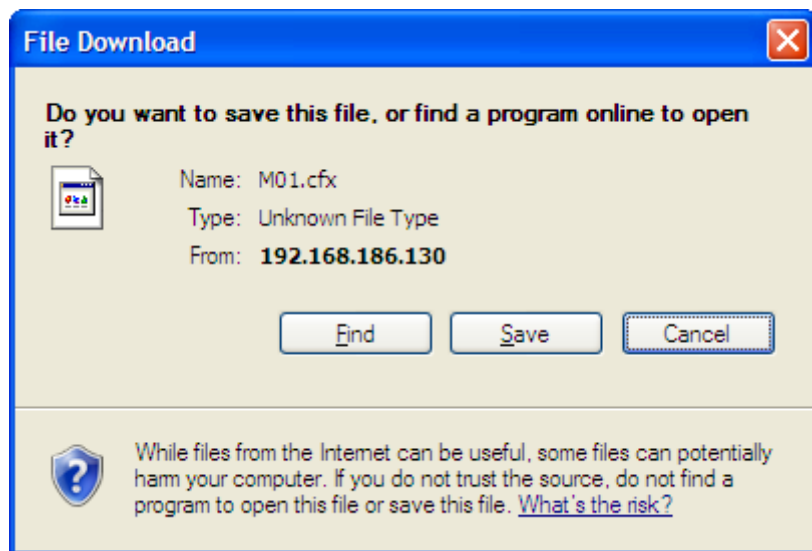

**Note:** This dialog may not appear instantaneously. The time the system needs to generate a CFX report depends on the number of items (including archive items, alarms, and events) it must include in the report. The greater the number of items, the more time the system needs to generate the report, and the longer the wait for this dialog to display.

5. Click **Save** and select a location and file name for the report. The default file name is `MXX_DD_MM_YYYY_hh_mm_ss.cfx`, where:
  - M** is meter
  - XX** is the meter number
  - DD\_MM\_YYYY** is the creation date (day, month, year) stamp for the file
  - hh\_mm\_ss** is the creation time stamp (hours, minutes, seconds) for the file.
6. Once you save the file, you can open it with dedicated tools.

## H.6 Understanding the CFX File Structure

---

As stated previously, the time stamps the system applies to generated CFX file reports are typically seconds after the end of the period. Understanding how the system creates CFX files can help.

First, the program creating CFX files uses components which are both time-dependent and time-independent:

- Header (**not** time-dependent)
- Meter configuration (time-dependent)
- Collection of historical items (time-dependent)
- Collection of alarms (time-dependent)
- Collection of events (time-dependent)
- File terminator (**not** time-dependent)

When you select a time range for a particular stream, the system searches for the newest meter configured for that range and all historical items, alarms, and events in that range.

For example, an “hourly” CFX report contains historic items for one hour of flow data. If you specify a start time of 10:00 and an end time of 14.01, the system generates a CFX file containing:

- A header
- A meter configuration at 14:00
- A collection of historical items:
  - 10:00 – flow data from 09:00 to 10:00
  - 11:00 – flow data from 10:00 to 11:00
  - 12:00 – flow data from 11:00 to 12:00
  - 13:00 – flow data from 12:00 to 13:00
  - 14:00 – flow data from 13:00 to 14:00
- A collection of all alarms generated between 09:00 and 14:00
- A collection of all events generated between 09:00 and 14:00
- A file terminator

All data collection begins at 09:00 but because the time stamp in the S600+ follows (“trails”) the flow data, flow data starts at 09:00, but the report generates at 10:00.

# Appendix I – Network Printing

## In This Chapter

I.1	Overview.....	I-1
	I.1.1 Supported Printers.....	I-2
	I.1.2 Supported Paper Sizes .....	I-2
I.2	Configuring Printers from PCSetup .....	I-2
I.3	Configuring Printers from the S600+ .....	I-4
	I.3.1 Configuring at Runtime.....	I-4
	I.3.2 Printer Options.....	I-4
I.4	Printing Retries.....	I-5
I.5	Editing Report Line Lengths.....	I-5
I.6	Network Printing Alarms.....	I-8

This appendix provides an overview of the Network Printing function.

**Note:** Network printing is available for CPU modules delivered from the factory with the binary (“firmware”) at 06.20 or greater. Although you can upgrade the binary on old CPU modules, network printing requires a **factory** upgrade of additional firmware. No user upgrade of these components is possible. If you wish to use network printing with old CPU modules, you **must** return them to the factory for firmware upgrades.

## I.1 Overview

Network printing enables you to use one or more printers connected in the same network with the S600+ to print reports, alarms, events and all other S600+-printable documents.



### Caution

**To ensure MID compliance, do not use network printing when the printer is legally controlled. In that case, use a serial printer with hardware handshaking.**

You can connect to and use a network printer without having to install printer drivers. Once a printer is connected to the network and given an IP address, you specify that IP address (as part of the printer configuration) and start using the printer.

**Note:** Advanced printer functions such as support for paper sizes **other** than metric A4 (297mm x 210 mm) or US letter (8.5in x 11 in), paper source, color printing, paper orientation, and so on are not currently available with this feature.

Printer configuration is minimized. Each network printer needs to have an IP address and a defined “print task” (reports, alarms, events, or a combination of the three). You can easily change these settings at run time.

The S600+ generates reports periodically and generates alarms and events as they occur. These are “printing tasks.” You assign each printer connected to the S600+ one or more tasks. For redundancy,

multiple printers can perform the same task. Report, alarm, and event printing can occur automatically and manually (from the front panel), since each task has specific triggers for automatic printing:

- Reports print as soon as they generate.
- Alarms and events print either as soon as the number of specified alarms/events since the last print has occurred or as soon as an “elapsed time since the last print” value exceeds the time specified in the configuration.

Network printing does not replace the option to connect a serial printer. This option is still available, and you can combine the two printing protocols as necessary.

### I.1.1 Supported Printers

The S600+ uses a generic network printing driver which supports a large number of printers by printing files in RAW format. This format implies that the file is sent to the printer as the S600+ generates it.

To determine if the printer is compatible, check whether port 9100 of the printer is open and whether the printer accepts RAW protocol.

### I.1.2 Supported Paper Sizes

Network printing currently supports only **two** sizes of paper: metric A4 (297mm x 210mm) and US letter (8.5in x 11in). Further, the function supports up to 78 characters per line for A4 paper and up to 80 characters per line for Letter paper.

---

**Note:** Refer to *Section I.5, Editing Report Line Lengths*, for information on adjusting the line lengths of the two supported paper sizes.

---

## I.2 Configuring Printers from PCSetup

---

Select **I/O Setup > Comms** from the PCSetup menu to define a printer as a communications link. Any communication link can be defined as a printer link by changing its function to **PRINTER**.

For each communication link that you set to **PRINTER**, you need to define the communication protocol and the communication port or IP address (depending on the protocol selected).

Additional printer settings include:

- Printing task (Alarm, Event, or Report)
- Trigger type for automatic printing of Alarms and Events (the timeout period of number of items)
- Values for each trigger

You can configure all the Comms links as printers. However, once you define a Comms link as a printer you **cannot** change it at runtime through either the Webserver or the Front Panel.



You can also define automatic printing triggers in the Comms menu (although this feature is available **only** for network printers). To enable a trigger type (based on a timeout or number of items), set its value to some non-zero value.

*Figure I-1* shows a serial printer configured for COM3; compare it to *Figure I-2*, which shows the configuration for a network printer.

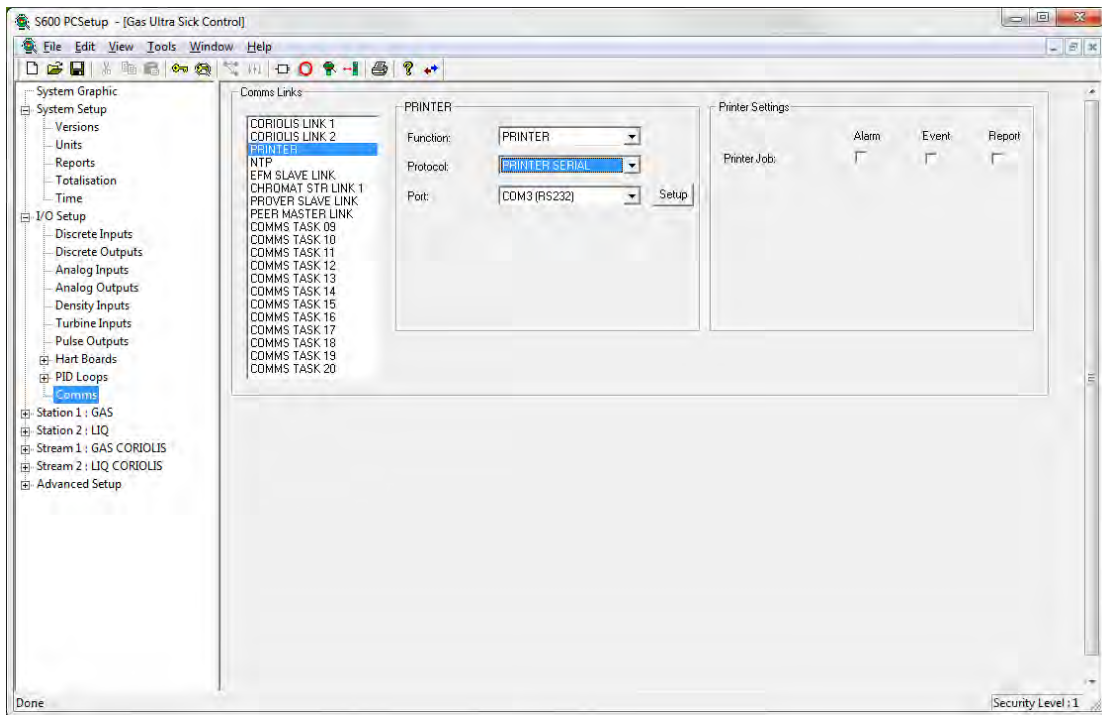

*Figure I-1. Defining a Serial Printer on COM3 Port*

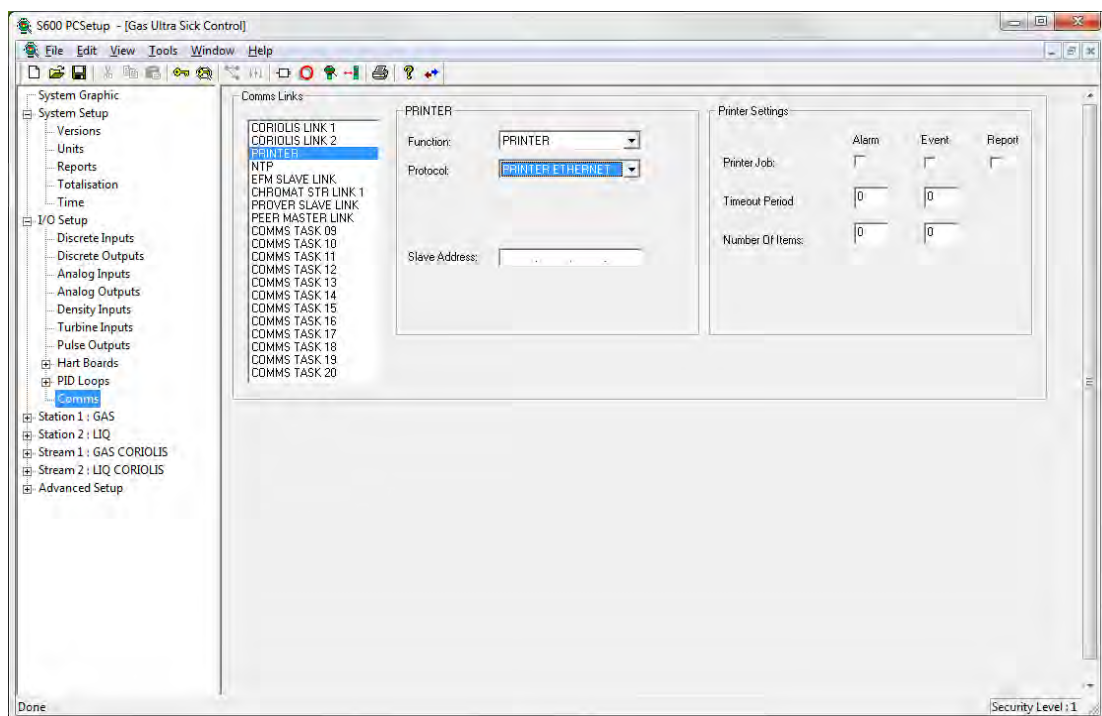

*Figure I-2. Defining a Network Printer*

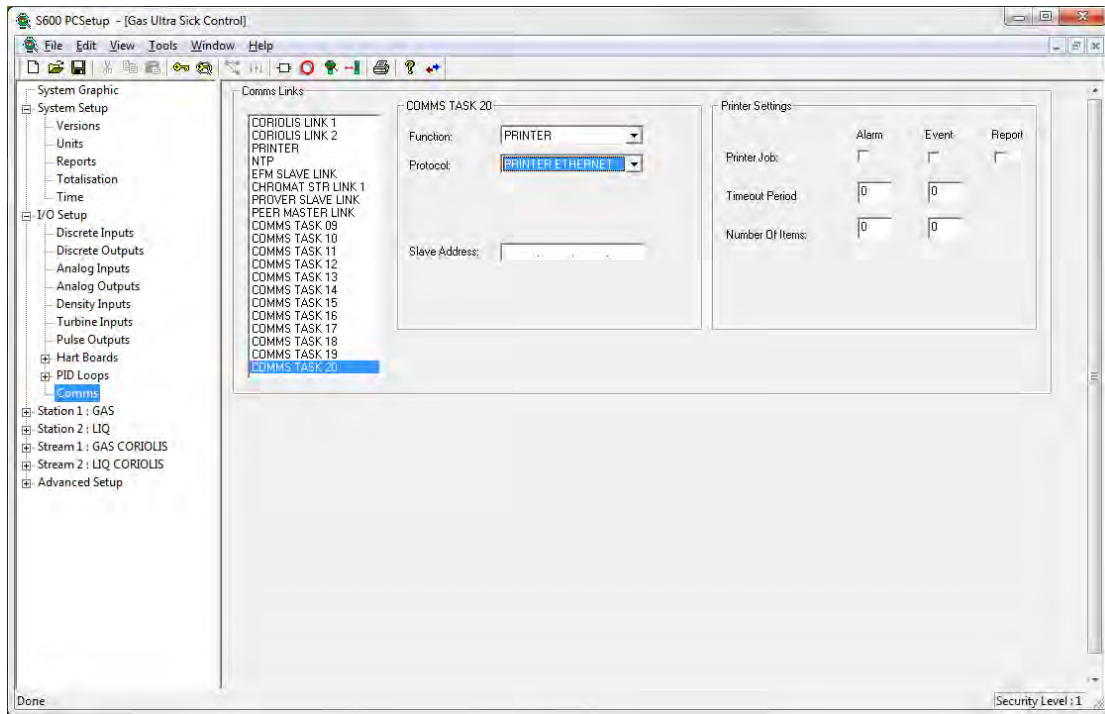

Figure I-3. Defining Comms Task 20 for the Printer

### I.3 Configuring Printers from the S600+

You can also configure a printer from the S600+ Front Panel or Webserver.

#### I.3.1 Configuring at Runtime

The system defines printer tasks as Comms links. To change the printer communication settings (protocol, IP or port) and the general printer options (printing task, trigger value) through the Webserver or the Front Panel, you must access the Communications section.

PRINTER 1 Port: PORT 3 Protocol MODBUS TCP	PRINTER 1 TCP/IP ADDRESS 10.97.23.32	PRINTER 1 Alarm Event     1 0	PRINTER 1 Report     1	PRINTER 1 Alarm trigger Timeout (mins)     0 No of alarms     10	PRINTER 1 Event trigger Timeout (mins)     0 No of events     0
--	---	--	---------------------------	---	--

#### I.3.2 Printer Options

You can edit printer options (printing task and triggers) through the Webserver and Front Panel.

**Printing Task** Select a print task by changing the value in the displays from zero (task not checked) to a value other than zero (task checked). The system then assigns all tasks with a non-zero value to the printer.

**Printing Trigger** You cannot edit the printing task directly. By using a non-zero value for a trigger value, that trigger value also sets the trigger type.

For example, if the Timeout trigger value is zero, printing is not triggered by Timeout. However, if you change that value to 1 minute,

the printer prints new alarms and events every minute, if there are new alarms and events.

## I.4 Printing Retries

While printing, the S600+ performs a number of retries reading the response from the printer after sending the print request. During this time the printing task does not send any other print requests to the printer. There is a one-second delay between each retry.

By default, the system has a maximum of 10 retries, so there is at most a 10-second interval between two print jobs. Depending on the network to which the S600+ and the printers are connected, more or fewer retries might be needed to be able to complete a print job.

You can change the maximum number of retries using the System Editor. Access the System section and edit the Keypad Integer (KPINT) named PRN MAX RETRIES.

**Note:** The System Editor is available **only** with Config600 Pro.

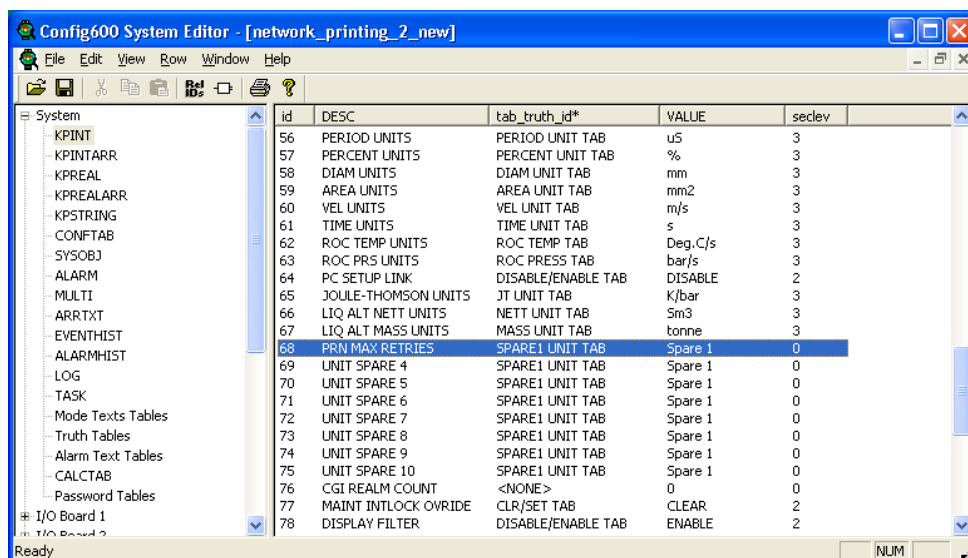

Figure I-4. Redefining Printer Retries

In case of a printer error, an alarm occurs. The S600+ then tries to reprint after a 1-minute wait from the previous failed print attempt. Further print attempts continue until the printer recovers from the error, the printer IP address changes (and a new printer is assigned), or the communication protocol changes.

## I.5 Editing Report Line Lengths

The Network Printing function currently supports two paper sizes, metric A4 (297 mm x 210 mm) and US letter (8.5 in x 11 in). US letter paper size is the default. A4 paper accommodates up to 78 characters per line, while US letter accommodates up to 80 characters per line. This section describes the process you use to adjust the line length for printed reports so that report content does not exceed the width of the page or the capability of your printer. For example, if your printer uses

A4 paper but can only accommodate 36 characters per line, use this procedure to adjust the report line length.

To edit report line lengths:

1. Access the System Editor application and open the configuration containing the reports you want to edit.
2. Using the left pane, select **System > KPINTARR**. From the resulting screen, double-click the **ALARM FORMAT** object.

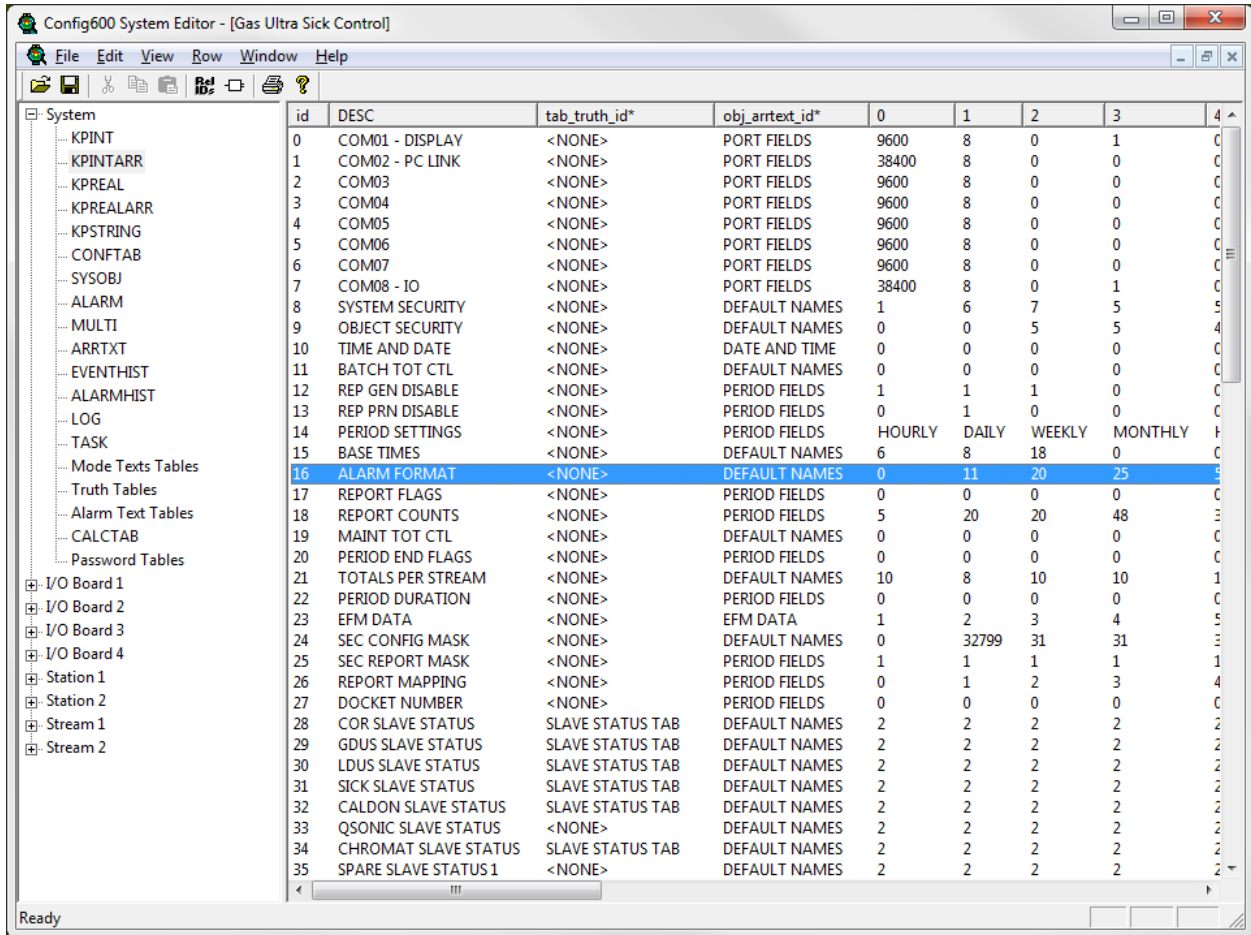

Figure I-5. Selecting the ALARM FORMAT Object

An Edit dialog displays:

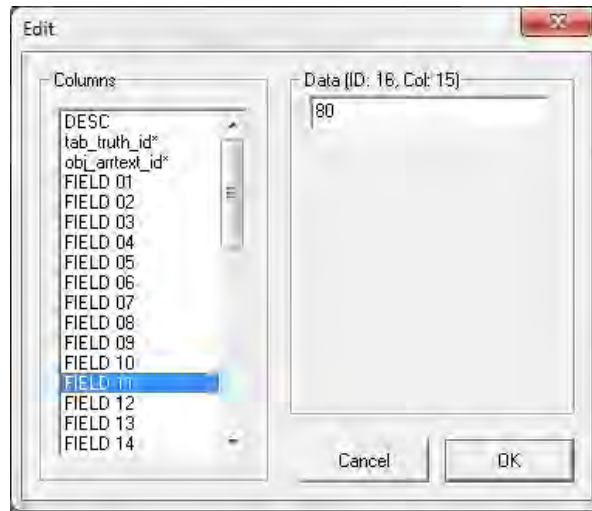

Figure I-6. Edit Dialog

Each item in the Column section is associated with a specific piece of information that appears on a report. The information appears on the report based on the position you define in the Data field. Position **0** appears at the start of the line. If you set a field to **-1** the system does not include that information on the report. *Table I-1* indicates the values of the fields:

Table I-1. Field Descriptions

Field	Description
01	Date; common for all report/log/archive types
02	Time; common for all report/log/archive types
03	Computer ID; common for all report/log/archive types
04	Object descriptor (alarm, archive, report, etc.); common data for most messages
05	Field descriptor (Value, InUse, etc.); common data for most messages
06	Alarm text (HH, LL, H, L, etc.); data for alarm messages
07	Alarm Status (SET, CLR, ACC); data for alarm messages
08	Alarm Value; data for alarm messages
09	Second line of two-line constant change message; data for constants change message
10	Value field (that is, the value stored in the Value field for a KPINT object); value field for several message types
11	Total number of characters in a log line; common for all log types.

**Note:** The value stored in all fields up to 11 **must be smaller** than the value specified in field 11.

3. Edit the value in field 11 and click **OK** to save your changes.

**Examples** The following examples show settings for various kinds of messages.

Alarm archive examples:

```

F1      F2      F3  F4      F5      F7      F11
0       11      20  25      50      63      80
↓       ↓       ↓   ↓       ↓       ↓       ↓
06/09/2013 08:48:45 S600 STR01 CORIOLIS FLOW I/P ERR CLR
    
```

```

F1      F2      F3  F4      F5      F7 F8      F11
0       11      20  25      50      63 65      80
↓       ↓       ↓   ↓       ↓       ↓   ↓       ↓
06/09/2013 09:31:49 S600 STR01 SERIAL DENS L CLR 50.000000
    
```

In the following example Field 03 is set to -1, which means that the computer ID does not display. Field 04 was moved forward 3 characters.

```

F1      F2      F3  F4      F5      F7 F8      F11
0       11      1  22      50      63 65      80
↓       ↓       ↓   ↓       ↓       ↓   ↓       ↓
04/09/2013 11:12:55 STR01 SERIAL DENS L SET
    
```

Event archive examples:

```

F1      F2      F3  F4      F5      F10      F11
0       11      20  25      50      63      80
↓       ↓       ↓   ↓       ↓       ↓       ↓
06/09/2013 08:48:45 S600 STR01 DENS SEL VALUE I/O
    
```

```

F1      F2      F3  F4      F6      F10      F11
0       11      20  25      50      63      80
↓       ↓       ↓   ↓       ↓       ↓       ↓
06/09/2013 09:31:20 S600 STR01 KP PULSE FREQ VALUE
                                CHANGED FROM 2.0000000E+01 TO 5.0000000E+01 Hz
                                ↑
                                F9
                                25
    
```

In the following example Fields 01 and 03 are both set to -1. All other relevant fields were set correspondingly to reduce the length of the archive line.

```

F2      F4      F6      F7      F11
0       11      25      42      60
↓       ↓       ↓       ↓       ↓
13:01:37 STR01 SERIAL PRESS MODE KEYPAD
    
```

## I.6 Network Printing Alarms

The table below shows the alarms that can be raised as part of the network printing functionality.

Alarm	Description
03	Idle
05	Error – The file has been sent to the printer, but no job id has been assigned so it cannot print.
06	Not Defined – No network printer has been configured.

<b>Alarm</b>	<b>Description</b>
08	Job Cancelled – Printing has been cancelled at the printer.
09	Job Error – The file has been sent to the printer but has not been completed or cancelled.
11	Not Acc Jobs – Buffer is full so no new jobs can be accepted.
12	No Net Print – Kernel does not support network printing.

---

**Note:** If network printing problems occur (i.e. multiple copies of a report), then the printer should be checked for any error messages (e.g. low toner) and these issues rectified. The FloBoss S600+ assumes any reports sent to the device will be printed correctly.

---

*[This page is intentionally left blank.]*



# Appendix J – Sampling

## In This Chapter

---

J.1	Overview.....	J-1
J.2	Input / Outputs .....	J-1
	J.2.1 Sampler Output.....	J-2
	J.2.2 Sampler Can Select Output.....	J-2
J.3	Sampling Options.....	J-2
	J.3.1 Sampler Method.....	J-2
	J.3.2 Sampler Mode .....	J-3
	J.3.3 Can Fill Indicator.....	J-4
	J.3.4 Auto Disable.....	J-4
	J.3.5 Auto Restart .....	J-4
J.4	Sampling Sequence.....	J-5
J.5	Sampling Alarms .....	J-10
J.6	Sampling Displays.....	J-11
J.7	Sampling – System Editor.....	J-13

---

This appendix provides an overview of the S600+ sampling functionality.

### Station or Stream Based

When creating a configuration, you can enable sampling either at the stream or at the station to which the stream is assigned, but not both.

---

**Note:** Refer to *Chapter 5 Station Configuration* or *Chapter 6 Stream Configuration* for details of sampling configuration screens.

---

## J.1 Overview

Sampling is the method by which a sample of the product being metered is collected in a sample container (can). When the can is full it can be removed and sent to a laboratory for analysis.

Whilst sampling is active, the FloBoss S600+ calculates the frequency of the samples (grabs) required to fill the can based on the input parameters. You can configure these parameters via the front panel / webserver or from a supervisory system.

Can full indication is provided, and support is also available for dual can sampling.

## J.2 Input / Outputs

You can configure the following inputs and outputs associated with the sampler.

**Inputs** In a configuration with sampling, the following inputs can be assigned:

Can 1 Fill Indication	4-20mA ADC
Can 2 Fill Indication	4-20mA ADC
Sampler Flow Rate Low	Digital Input
Sampler Can 1 High	Digital Input
Sampler Can 2 High	Digital Input

Flow Switch (Flow Prop 3 Only)	Digital Input
Pressure Switch (Flow Prop 3 Only)	Digital Input

---

**Notes:**

- Some (or none) of these inputs may be required, depending on the sampling configuration.
  - The Can 1 and Can 2 Fill Indication 4-20mA ADC Low and High Scale values should be configured to correspond to the Can Volume of the sampler.
  - The flow switch and pressure switch digital inputs are not available by default. They are specific to the FLOW PROP 3 (ANP sampling) functionality and need to be added via the system editor if required.
- 

**Outputs** In a configuration with sampling, the following outputs can be assigned:

Sampler Output (Grab Command)	Digital Output
Sampler Can Select Output	Digital Output

### J.2.1 Sampler Output

The S600+ sampler logic sets the Sampler Output (Grab Command) digital output to command the sampler to take a grab. The time between grabs is called the Grab Interval and is calculated based on the Sampler Method selected.

If the Sampler Output (Grab Command) digital output is configured with Sense = Normal, the duration of the grab signal is equal to the Minimum Interval value, with a minimum value of 3 seconds.

If a shorter duration is required, the Sense = Pulse On should be selected and the Pulse Width set to the required duration.

For Flow Prop 3 mode, the Sampler Output duration is dictated by the Sampler Pulse Duration (default 3 sec).

### J.2.2 Sampler Can Select Output

In Dual mode, when Can Selected = 1, the Sampler Can Select Output is cleared; when Can Selected = 2, the Sampler Can Select Output is set.

---

## J.3 Sampling Options

You can configure many sampler options including Sampler Method, Sampler Mode, Can Fill Indicator, Auto Disable, and Auto Restart.

### J.3.1 Sampler Method

The Sampler Method determines the grab interval. Possible options are Time Prop, Flow Prop 1, Flow Prop 2, and Flow Prop 3.

- Time Prop** In this mode the grab interval is in seconds.  
The number of grabs required to fill the can is calculated from the Can Volume and Grab Volume.  
Number of grabs = Can volume (m<sup>3</sup>) / Grab volume (m<sup>3</sup>)  
The Grab interval is then calculated from the Number of grabs and the Can fill period.  
Grab interval (s) = Can fill period (hrs) \* 3600 / Number of grabs
- Flow Prop 1** In this mode the grab interval is in volume (m<sup>3</sup>).  
The number of grabs required to fill the can is calculated from the Can Volume and Grab Volume.  
Number of grabs = Can volume (m<sup>3</sup>) / Grab volume (m<sup>3</sup>)  
The Grab interval is then calculated from the Number of grabs and the Can volume.  
Grab interval (m<sup>3</sup>) = Expected volume (m<sup>3</sup>) / Number of grabs
- Flow Prop 2** In this mode the grab interval is in volume (m<sup>3</sup>) and is equal to the expected volume (m<sup>3</sup>).
- Flow Prop 3** In this mode the grab interval is in volume (m<sup>3</sup>) and is equal to the expected volume (m<sup>3</sup>).  
It also supports the pressure switch and flow switch digital inputs. If the pressure switch is set during sampling, sampling will be stopped. When the Sampler Output has been set to take a grab, the system expects the flow switch to be set.

### J.3.2 Sampler Mode

The Sampler Mode determines the number of containers used by the sampler.

**SINGLE/DUAL** In SINGLE mode, the samples are acquired in one can. In DUAL mode, the samples are acquired into two cans and the sampler switches to the second can when the first can is full (according to the Twin Can Changeover Mode selection).

**Twin Can Changeover Mode** You can set the can changeover to AUTO (automatically change over to the second can when the first is full) or MANUAL (sampling pauses when the first can is full and requires you to change the value of Sampler Can Select Output before sampling continues on the second can).

---

**Notes:**

- If sampling is stopped because both cans are full, the Twin Can Changeover Mode is set to MANUAL by the system. You must set back to AUTO if required.
  - Additionally, the display for Twin Can Changeover Mode must be manually added to the displays.
-

### J.3.3 Can Fill Indicator

The Can Fill Indicator is used by the system to determine when the sampler container is full.

**Grab Count** Uses the number of grabs taken to determine when the can is full.

Grabs Count and Grab Volume are used to calculate Can Volume Filled. When Can Volume Filled is greater than Can High High Percent of Can Volume, the Can Full Status is set.

**Digital Input** Uses Sampler Can 1 High digital input to determine when the can is full.

Grab Count and Grab Volume are used to calculate the Can Volume Filled. When the Sampler Can 1 High digital input (shown as Can Full I/O Status) is set, the Can Full Status is set.

**Analog Input** Uses Can x Fill Indication 4-20mA ADC input to determine when the can is full.

The Can x Fill Indication 4-20mA ADC input (shown as Can Fill Indicator) is used to calculate the Can Volume Filled. When the Can Volume Filled is greater than the Can High High Percent of Can Volume, the Can Full Status is set.

### J.3.4 Auto Disable

The system stops sampling based on your selection in the Auto Disable field. You can select more than one Auto Disable option.

**On Can Full** The system stops sampling if the Can Full Status for the current can is set.

The sampling sequence stage number changes to 6, Stopped Can Full.

Sampling continues on the second can if the Sampler mode is set to DUAL, the Twin Can Changeover Mode is set to AUTO, and the second can is available.

**On Flowrate Limit** The system stops sampling if the stream or station gross volume flow rate drops below the Flow Rate Low Limit.

The sampling sequence stage number changes to 7, Stopped Low Flow.

**On Flow Status** System stops sampling if the Sampler Flow Rate Low digital input set.

The sampling sequence stage number changes to 7, Stopped Low Flow.

### J.3.5 Auto Restart

If enabled, sampling restarts automatically following a pause for Can Full, Flowrate Limit, or Flow Status after the condition has cleared.

If disabled, you must manually restart sampling by setting Start Command to Start after the condition has cleared.

## J.4 Sampling Sequence

The sampling sequence functions in stages. *Table J-1* shows the stages involved.

Note that some of the stages are only applicable to certain sampling methods as indicated.

*Table J-1. Sampling Sequence Stages*

Stage	Title	Description
0	Idle	<p><b>Wait for a command to start the sequence.</b></p> <p>Clear all sampler alarms.</p> <p>Handle reset can volume command.</p> <p>Check Operator Commands:</p> <ul style="list-style-type: none"> <li>▪ If the Start command has been issued: <ul style="list-style-type: none"> <li>○ If mode is FLOW PROP 3, reset cans, set Sampler Output digital output, increment grab counters and proceed to stage 8 (Initial Time).</li> <li>○ Else proceed to stage 1 (Monitor).</li> </ul> </li> </ul>

Stage	Title	Description
1	Monitor	<p><b>Monitor sampler status.</b></p> <p>Handle reset volume command.</p> <p>Check Operator Commands:</p> <ul style="list-style-type: none"> <li>▪ If the Stop command has been issued, proceed to stage 5 (Stopped Manually) and set 'Sampler Stopped when Flowing' alarm (if flow is present).</li> <li>▪ If the Terminate command has been issued, proceed to stage 0 (Idle). <b>Note:</b> This is only applicable if mode is FLOW PROP 3 and is not available by default. It would need to be added via the system editor if required.</li> </ul> <p>Check Can(s) Full, if set:</p> <ul style="list-style-type: none"> <li>▪ If mode is FLOW PROP 3, proceed to stage 0 (Idle).</li> <li>▪ All other modes proceed to stage 6 (Stopped Can Full) or stage 13 (Can Switch Over – Dual Can AUTO only).</li> </ul> <p>Check Low Flow Status, if set:</p> <ul style="list-style-type: none"> <li>▪ If mode is FLOW PROP 3, proceed to stage 0 (Idle).</li> <li>▪ All other modes proceed to stage 7 (Stopped Low Flow) and set 'sampler stopped when flowing' alarm if flow is present.</li> </ul> <p>Check if grab required (including overruns awaiting output):</p> <ul style="list-style-type: none"> <li>▪ If mode is FLOW PROP 3, check pressure switch. <ul style="list-style-type: none"> <li>○ If pressure switch ON, proceed to stage 11 (Stopped Pressure Switch) and raise 'Pressure Switch' alarm.</li> <li>○ If pressure switch OFF, proceed to stage 9 (Check Flow Switch).</li> </ul> </li> <li>▪ If grab required, proceed to stage 2 (Digital Output 'n'), set Sampler Output digital output, increment grab counters and increment current can volume (Grab Count and Dig I/P).</li> <li>▪ If no grabs required, stay in stage 1 (Monitor).</li> <li>▪ If mode is FLOW PROP 1 or FLOW PROP 2: <ul style="list-style-type: none"> <li>○ If number of grabs required &gt; 1, increase overruns by (number of grabs required – 1).</li> </ul> </li> </ul>
2	Digital Output 'n'	<p><b>Synchronize with IO communications</b></p> <p>Handle reset volume command.</p> <p>Check Operator Commands:</p> <ul style="list-style-type: none"> <li>▪ If the Stop command has been issued, maintain the digital output for the configured time then proceed to stage 5 (Stopped Manually) and set 'Sampler Stopped when Flowing' alarm (if flow is present).</li> <li>▪ If the Terminate command has been issued, maintain the digital output for the configured time then proceed to stage 0 (Idle).</li> </ul> <p>Check Pressure Switch:</p> <ul style="list-style-type: none"> <li>▪ If mode is FLOW PROP 3, check pressure switch. <ul style="list-style-type: none"> <li>○ If pressure switch ON, proceed to stage 11 (Stopped Pressure Switch) and raise 'Pressure Switch' alarm.</li> </ul> </li> </ul> <p>Allow the command to be registered by the IO handling task.</p> <p>Proceed to stage 3 (Minimum Interval).</p>

Stage	Title	Description
3	Minimum Interval	<p><b>Ensure a delay between sampler pulses.</b></p> <p>Handle reset volume command.</p> <p>Check Operator Commands:</p> <ul style="list-style-type: none"> <li>▪ If the Stop command has been issued, proceed to stage 5 (Stopped Manually) and set 'Sampler Stopped when Flowing' alarm (if flow is present).</li> <li>▪ If the Terminate command has been issued, proceed to stage 0 (Idle).</li> </ul> <p>Check Pressure Switch:</p> <ul style="list-style-type: none"> <li>▪ If mode is FLOW PROP 3, check pressure switch. <ul style="list-style-type: none"> <li>○ If pressure switch ON, proceed to stage 11 (Stopped Pressure Switch) and raise 'Pressure Switch' alarm.</li> </ul> </li> </ul> <p>Check Can(s) Full, if set:</p> <ul style="list-style-type: none"> <li>▪ If mode is FLOW PROP 3, proceed to stage 0 (Idle).</li> <li>▪ All other modes, proceed to stage 6 (Stopped Can Full) or stage 13 (Can Switch Over – Dual Can AUTO only).</li> </ul> <p>Once the minimum interval between pulses has been reached, clear Sampler Output digital output. Proceed to stage 4 (Post Pulse).</p>
4	Post Pulse	<p><b>Post Pulse Output Delay</b></p> <p>Allow the command to be registered by the IO handling task.</p> <p>Proceed to stage 1 (Monitor).</p>
5	Stopped Manually	<p><b>Sampler has been stopped manually</b></p> <p>Handle reset volume command.</p> <p>Check Operator Commands:</p> <ul style="list-style-type: none"> <li>▪ If the Start command has been issued, proceed to stage 1 (Monitor).</li> <li>▪ If the Stop command has been issued, proceed to stage 0 (Idle).</li> </ul> <p>Raise can full alarms if required.</p>
6	Stopped Can Full	<p><b>Sampler has been stopped – can(s) full</b></p> <p>Handle reset volume command.</p> <p>Check Operator Commands:</p> <ul style="list-style-type: none"> <li>▪ If the Start command has been issued, proceed to stage 1 (Monitor).</li> <li>▪ If the Stop command has been issued, proceed to stage 0 (Idle).</li> </ul> <p>Raise low flow alarms if required.</p> <p>If auto restart is enabled, can is not full, and low flow status clear, proceed to stage 1 (Monitor).</p>

Stage	Title	Description
7	Stopped Low Flow	<p><b>Sampler has been stopped – low flow</b></p> <p>Handle reset volume command.</p> <p>Check Operator Commands:</p> <ul style="list-style-type: none"> <li>▪ If the Start command has been issued, proceed to stage 1 (Monitor).</li> <li>▪ If the Stop command has been issued, proceed to stage 0 (Idle).</li> </ul> <p>Raise can full alarms if required.</p> <p>Raise low flow alarms if required.</p> <p>If auto restart is enabled, can is not full, and low flow status clear, proceed to stage 1 (Monitor).</p>
8	Initial Time	<p><b>Monitor for sampler ready feedback</b></p> <p>Flow Prop 3 Mode Only.</p> <p>Check Operator Commands:</p> <ul style="list-style-type: none"> <li>▪ If the Stop command has been issued, proceed to stage 0 (Idle).</li> </ul> <p>Check Pressure Switch:</p> <ul style="list-style-type: none"> <li>▪ If mode is FLOW PROP 3, check pressure switch. <ul style="list-style-type: none"> <li>○ If pressure switch ON, proceed to stage 11 (Stopped Pressure Switch) and raise 'Pressure Switch' alarm.</li> </ul> </li> </ul> <p>Check Initial Flow Switch Feedback:</p> <ul style="list-style-type: none"> <li>▪ If mode is FLOW PROP 3, check flow switch. <ul style="list-style-type: none"> <li>○ Wait for Sampler Pulse Duration to expire (default 3 sec) then clear Sampler Output digital output.</li> <li>○ If Flow Switch digital input set, proceed to stage 1 (Monitor).</li> <li>○ If Flow Switch digital input clear, set Sampler Output digital output again and check for Flow Switch digital input.</li> <li>○ Repeat for Initial Actuations (default 5) until Flow Switch digital input set.</li> </ul> </li> </ul> <p>If no feedback received from Flow Switch, proceed to stage 12 (Stopped Initialise) and set 'Sampler Failed to Initialise' alarm.</p>



Stage	Title	Description
9	Check Flow Switch	<p><b>Monitor Flow Switch status</b></p> <p>Flow Prop 3 Mode Only</p> <p>Check Operator Commands:</p> <ul style="list-style-type: none"> <li>▪ If the Stop command has been issued, proceed to stage 0 (Idle).</li> </ul> <p>Check Pressure Switch:</p> <ul style="list-style-type: none"> <li>▪ If mode is FLOW PROP 3, check pressure switch. <ul style="list-style-type: none"> <li>○ If pressure switch ON, proceed to stage 11 (Stopped Pressure Switch) and raise 'Pressure Switch' alarm.</li> </ul> </li> </ul> <p>Check Flow Switch:</p> <ul style="list-style-type: none"> <li>▪ If mode is FLOW PROP 3, check flow switch. <ul style="list-style-type: none"> <li>○ Wait for Sampler Pulse Duration to expire (default 3 sec) then clear Sampler Output digital output.</li> <li>○ If Flow Switch digital input set, proceed to stage 3 (Minimum Interval).</li> <li>○ If Flow Switch digital input clear for &gt; 1 sec, raise 'Flow Switch Fail' alarm and proceed to stage 3 (Minimum Interval).</li> </ul> </li> </ul>
10	Not Used	
11	Stopped Press Switch	<p><b>Sampler has been stopped – pressure switch</b></p> <p>Flow Prop 3 Mode Only.</p> <p>Handle reset volume command.</p> <p>Check Operator Commands:</p> <ul style="list-style-type: none"> <li>▪ If the Start command has been issued, proceed to stage 1 (Monitor).</li> <li>▪ If the Stop command has been issued, proceed to stage 0 (Idle).</li> </ul> <p>Raise can full alarms if required.</p> <p>Check Pressure Switch:</p> <ul style="list-style-type: none"> <li>▪ If pressure switch OFF, proceed to stage 1 (Monitor) and clear 'Pressure Switch' alarm</li> </ul>
12	Stopped Initialise	<p><b>Sampler has been stopped – failed to initialise</b></p> <p>Flow Prop 3 Mode Only.</p> <p>Handle reset volume command.</p> <p>Check Operator Commands:</p> <ul style="list-style-type: none"> <li>▪ If the Start command has been issued, proceed to stage 3 (Initial Time).</li> <li>▪ If the Stop command has been issued, proceed to stage 0 (Idle).</li> </ul>

Stage	Title	Description
13	Can Switch Over	<p><b>Switchover Cans</b></p> <p>Dual Can Mode Only.</p> <p>Handle reset volume command.</p> <p>Check Operator Commands:</p> <ul style="list-style-type: none"> <li>▪ If the Stop command has been issued, proceed to stage 5 (Stopped Manually) and set 'Sampler Stopped when Flowing' alarm if flow is present.</li> <li>▪ If the Terminate command has been issued, proceed to stage 0 (Idle).</li> </ul> <p>Switch Can Selected, switch Sampler Can Select Output.</p> <p>Once changeover time has elapsed, proceed to stage 1 (Monitor).</p>

## J.5 Sampling Alarms

---

Table J-2 shows the alarms that can be raised as part of the sampling functionality.

The alarm limits / dead bands are calculated based on the can volume and the operator entered percentages.

High limit = can volume \* (can high limit / 100)

High high limit = can volume \* (can high high limit / 100)

High dead band = can volume \* ((high limit – 2.0) / 100)

High high dead band = can volume \* ((high high limit – 2.0) / 100)

*Table J-2. Sampling Alarms*

Alarm	Description
<b>Can x Full</b>	Volume greater than or equal to the High High limit (Grab Count, Analogue Input). Digital input ON (Digital Input) .
<b>Can x High</b>	Volume greater than or equal to the High limit. Alarm is cleared when the volume is less than the high dead band.
<b>Speed</b>	In Time Prop mode: The configured time proportional interval is less than the minimum interval (This cannot be less than 1 second). In Flow Prop 1 and Flow Prop 2 modes: The number of overruns is greater than 10. (Alarm cleared when number of overruns is less than 6).
<b>Stopped</b>	The sampler has been stopped but flow is still present.
<b>Low Flow</b>	The sampler has been automatically stopped. The flow rate is below the low flow limit.
<b>Flow Switch</b>	Flow Prop 3 Mode Only. The sampler has been automatically stopped. The flow switch digital input status has been set to OFF for more than the permitted time (1 second).
<b>Press Switch</b>	Flow Prop 3 Mode Only. The sampler has been automatically stopped. The pressure switch digital input status is set to ON.

<b>Alarm</b>	<b>Description</b>
<b>Init Fail</b>	Flow Prop 3 Mode Only. The sampler has been automatically stopped. The number of initial grabs taken has exceeded the maximum allowed before the flow switch signal is received from the sampler.
<b>FSW Stuck</b>	Flow Prop 3 Mode Only. The sampler has been automatically stopped. The flow switch has been ON for more than the permitted time (FSW On Limit, default 2 sec).

## J.6 Sampling Displays

The following table describes the displays associated with sampling. Access the displays through the S600+ front panel or web browser.

*Table J-3. Sampling Displays*

<b>Display (SAMP PARAMS)</b>	<b>Description</b>
<b>SAMPLER METHOD</b>	Identifies the sampling method in use as described in section J.3.
<b>SAMPLER MODE</b>	Single Can or Dual Can.
<b>CAN FILL INDICATOR</b>	Identifies the method by which the can full indication is obtained (Grab Count, Digital input, Analogue input).
<b>A / DISABLE CAN FULL</b>	Auto disable on can full – enable / disable.
<b>A / DISABLE F/R LIM</b>	Auto disable on flow rate limit – enable / disable.
<b>A / DISABLE F/R STAT</b>	Auto disable on flow status (Sampler Flow Rate Low digital input) – enable / disable.
<b>A / RESTART</b>	Auto restart (following auto disable) – enable / disable.
<b>EXPECTED VOL</b>	Volume (m3) over which samples are to be taken to fill can – used in Flow Prop modes.
<b>PERIOD</b>	Time (hours) over which samples are to be taken to fill can – used in Time Prop mode.
<b>FR LOW LIMIT</b>	Low limit for auto disable on flow rate limit option.
<b>TIME PROP INTERVAL</b>	Calculated time (s) between grabs – used in Time Prop mode.
<b>MINIMUM INTERVAL</b>	Indicates minimum time (seconds) between grabs.
<b>CAN VOLUME</b>	Total can volume.
<b>GRAB VOLUME</b>	Required grab volume.
<b>CAN LOW PERCENT</b>	Not used.
<b>CAN HH PERCENT</b>	High High alarm value as a percentage of the can volume. Used to indicate can full.
<b>CAN H PERCENT</b>	High alarm value as a percentage of the can volume.

Display (SAMP CONTROL)	Description
<b>START COMMAND</b>	Start or Stop sampling command. <b>Note:</b> Following a cold start, Reset Can x Vol must be carried out for Can Selected before Start sampling command will be accepted. (Does not apply to Flow Prop 3).
<b>CAN SELECTED</b>	Can 1 or Can 2 (will show can 1 in single can mode).
<b>STAGE No</b>	Current sampling stage.
<b>LOW FLOW STATUS</b>	Set to CLEAR when flow above the flow rate low limit value, otherwise SET. Also set by Sampler Flow Rate Low digital input.
<b>OVERRUNS</b>	In Flow Prop 1 or Flow Prop 2, if number of grabs required based on the flow increment is greater than 1, overruns will be incremented by (number of grabs required - 1). <b>Note:</b> If sampling has been paused and restarted, overruns will still be calculated based on the flow increment since the last grab was taken.  The sampler will attempt to “catch up” by issuing grabs to decrease the number of overruns, if permitted by the values of Minimum Interval, Expected Volume and volume flow rate.

Display (SAMP CAN x)	Description
<b>RESET CAN x VOL</b>	Updates Can Fill Indicator and Can Volume Recalculates Grabs to Fill Can and Time Prop Interval  Resets Grabs Count, Grabs Remaining, Overruns, Can Vol Filled and Can Vol Remaining. <b>Note:</b> If Can Fill Indicator = ANALOG I/P, Can Vol Filled and Can Vol Remaining are not reset.  Clears various sampler alarms.
<b>GRABS COUNT</b>	Current grab count.
<b>GRABS REMAINING</b>	Grabs remaining before the can is full.
<b>GRABS TO FILL CAN</b>	Calculated number of grabs to fill the can.
<b>CAN VOL FILLED</b>	Volume (m3) that is currently in the can.
<b>CAN VOL REMAINING</b>	Volume (m3) equal to (Can Volume – Can Vol Filled).
<b>CAN FULL STATUS</b>	Set to CLEAR when can is not full, otherwise SET.
<b>CAN FULL I/O STAT</b>	Current status of Sampler Can X High digital input. Applies when using Can Fill Indicator = Dig. I/P.

---

<b>CAN FILL INDICATOR</b>	Current value of Can X Fill Indication 4-20mA ADC. Applies when using Can Fill Indicator = Analog I/P.
---------------------------	--

---

## **J.7 Sampling – System Editor**

---

For Flow Prop 3 mode, you must configure additional digital inputs used by the system for the flow switch and pressure switch.

For Flow Prop 3 mode, the terminate command must be added to the SAMP RUN CMNDS truth table (Ctext 4 = TERMINATE, sval4 = 3).

---

**Note:** System editor is available **only** with the Config600 Pro software and requires completion of the RA901 Advanced Config600 Training Course.

---

*[This page is intentionally left blank.]*

## Appendix K – Gas Composition

### In This Chapter

K.1	Station/Stream Combinations .....	K-2
K.2	Gas Composition Modes .....	K-4
	K.2.1 CHROMAT Mode .....	K-4
	K.2.2 KEYPAD Mode .....	K-4
	K.2.3 DOWNLOAD Mode .....	K-5
	K.2.4 USER Mode .....	K-6
	K.2.5 Mode Selection .....	K-6
K.3	Chromat Telemetry .....	K-8
	K.3.1 Telemetry Inputs .....	K-8
	K.3.2 Telemetry Outputs .....	K-9
	K.3.3 EURO Stages .....	K-11
	K.3.4 USA Stages .....	K-16
	K.3.5 Siemens Stages .....	K-20
	K.3.6 Generic Stages .....	K-21
K.4	Composition Processing .....	K-23
	K.4.1 Component Ordering .....	K-23
	K.4.2 High/Low Limits .....	K-25
	K.4.3 Deviation .....	K-26
	K.4.4 Normalisation .....	K-26
	K.4.5 Additional .....	K-27
	K.4.6 Splits .....	K-27
	K.4.7 Critical Alarms .....	K-30
	K.4.8 Non-Critical Alarms .....	K-30
	K.4.9 Timeouts .....	K-31
K.5	Auxiliary Data .....	K-31
	K.5.1 EURO (2551 / 2350 EURO) + USA (2251 / 2350 USA) .....	K-32
	K.5.2 SIEMENS + GENERIC .....	K-32
	K.5.3 Station to Stream Copying .....	K-32
K.6	Dual GC Handling .....	K-33
	K.6.1 CHROMAT A .....	K-33
	K.6.2 CHROMAT B .....	K-33
	K.6.3 CHROMAT AUTO .....	K-34
K.7	Displays .....	K-34
	K.7.1 Default Displays .....	K-34
K.8	Alarms .....	K-35
	K.8.1 Default Alarms .....	K-35
K.9	Reports .....	K-37
	K.9.1 CHR TELEMETRY .....	K-37
	K.9.2 CHR D/LOAD .....	K-39
K.10	Modbus Maps .....	K-41
K.11	User Customisation – How Tos .....	K-42
	K.11.1 SIEMENS GC .....	K-43
	K.11.2 GENERIC GC .....	K-43
	K.11.3 Multi-dropped GCs .....	K-43
	K.11.4 Mole Select - Keypad Fail Switchback .....	K-43
	K.11.5 Download Flag .....	K-43

This appendix details the options available for Gas Composition handling, including single or dual interfaces direct from the flow computer to a gas chromatograph.

The following chromatograph interfaces (Serial or Ethernet) are currently supported:

- 2551 Euro
- 2350 Euro (in SIM2551 emulation mode)
- 2350 USA (in SIM2251 emulation mode)
- 2251 USA
- Siemens
- Generic (user-configurable)

Information on setting up the Serial / Ethernet communications interfaces can be found in *Section 4.10, Communications Port*.

The following terminology is used within this appendix:

- GC/chromat – Gas Chromatograph
- Station – refers to Station functionality in the S600+
- Stream – refers to Stream functionality in the S600+
- GC Stream – refers to the GC Analysis stream

## K.1 Station/Stream Combinations

---

During config generation, various station and metering stream combinations are available:

- **Moles at Individual Stream** – No chromat handling at the station level, all handling is carried out at the stream(s).
- **Moles from Station Only** – No chromat handling at the stream level, all handling is carried out at the station and data copied to the stream(s).
- **Moles from Station Chromat** – Interface to chromat is at station level and data passed to stream(s). Some handling is carried out at stream level.

The following table describes possible station and stream combinations and how they are to be configured in Config Generator and PCSetup.

These options are also detailed in *Section 2.1.4, Specify Stations* and *Section 2.1.5, Define Streams*.

---

**Note:** The Config Generation Station options include Single Chromat and Dual Chromat. Dual Chromat functions are described in *Section K.6, Dual GC Handling*.

---



Table K-1. Station/Stream Combinations

Option	Generation			Comms Links			Station Gas Composition			Stream 1 Gas Composition			Stream 2 Gas Composition			Description		
	Station	Stream 1	Stream 2	CHROMAT STN LINK 1	CHROMAT STR LINK 1	CHROMAT STR LINK 2	Type	Address	Stream	Type	Station Number	Address	Stream	Type	Station Number		Address	Stream
1	No Chromat	Moles at Individual Stream	Moles at Individual Stream	Not Available	Disabled	Disabled	Not Available	Not Available	Not Available	KP ONLY	Not Used	Not Available	Not Available	KP ONLY	Not Used	Not Available	Not Available	Streams using individual Keypad composition. Each stream has optional Download or User composition.
2	No Chromat	Moles at Individual Stream	Moles at Individual Stream	Not Available	Enabled	Enabled	Not Available	Not Available	Not Available	CHROMAT A	Not Used	X	J	CHROMAT A	Not Used	Y	K	Each stream connected to dedicated GC, accepts results for analysis stream J/K. Address values must be different. Each stream has optional Keypad, Download or User composition.
3	No Chromat	Moles at Individual Stream	Moles at Individual Stream	Not Available	Enabled	Disabled	Not Available	Not Available	Not Available	CHROMAT A	Not Used	X	J	CHROMAT A	Not Used	X	K	Streams connected to common GC, Stream 1 accepts GC analysis stream J, Stream 2 accepts GC analysis stream K. Address values must be the same. Each stream has optional Keypad, Download or User composition.
4	Chromat	Moles From Station Only	Moles From Station Only	Disabled	Disabled	Disabled	KP ONLY	Not Available	Not Available	Not Available	Not Available	Not Available	Not Available	Not Available	Not Available	Not Available	Not Available	Station using Keypad composition. Station has optional Download or User composition. Checks applied at Station. Streams use in-use Station composition.
5	Chromat	Moles From Station Only	Moles From Station Only	Enabled	Disabled	Disabled	CHROMAT X	Not Used	O	Not Available	Not Available	Not Available	Not Available	Not Available	Not Available	Not Available	Not Available	Station connected to GC. Accepts any GC analysis stream. Station has optional Keypad, Download or User composition. Checks/Splits/Addnls applied at Station. Streams use in-use Station composition.
6	Chromat	Moles From Station Only	Moles From Station Only	Enabled	Disabled	Disabled	CHROMAT X	Not Used	L	Not Available	Not Available	Not Available	Not Available	Not Available	Not Available	Not Available	Not Available	Station connected to GC. Accepts GC analysis stream L. Station has optional Keypad, Download or User composition. Checks/Splits/Addnls applied at Station. Streams use in-use Station composition.
7	Chromat	Moles From Station Chromat	Moles From Station Chromat	Enabled	Disabled	Disabled	CHROMAT X	Not Used	O	CHROMAT A	1	Not Used	J	CHROMAT A	1	Not Used	K	Station connected to GC. Station accepts any GC analysis stream. Stream 1 accepts GC analysis stream J, Stream 2 accepts GC analysis stream K. Each stream has optional Keypad, Download or User composition. Checks/Splits/Addnls applied at Stream.

## K.2 Gas Composition Modes

---

Several modes are available for gas composition. These can be selected using Initial Mode on the Station Gas Composition and Stream Gas Composition displays in PCSetup, or under MOLE SELECT on the flow computer displays.

The data available on the Gas Composition screen changes depending on the selections made. Refer to *Section 5.5, Station Gas Composition* and *Section 6.3.4, Stream Gas Composition* for more details.

The following sub-sections describe these modes, which data set they correspond to, and how they are processed by the S600+. Detailed descriptions of composition processing are given in *Section K.4, Composition Processing*.

### K.2.1 CHROMAT Mode

In CHROMAT mode, the S600+ reads a gas composition from a GC via a Modbus link, with processing and checks optionally applied.

Note that CHROMAT mode can only be used when the Type (set on the Station Gas Composition and Stream Gas Composition screens), is set to CHROMAT A (Single / Dual GC) or CHROMAT B / CHROMAT AUTO (Dual GC) in PCSetup.

In CHROMAT mode, the Station or Stream good chromat set (CHR GOOD MOLES) becomes the in-use gas composition (CHR SLCT MOLES).

The raw composition set read from the GC passes through several validation and processing steps before becoming the good chromat set – namely components ordering, high/low limits check, deviation checks, normalisation, additional component processing, CX+ component splitting, critical and non-critical alarm checks. These are described in *Section K.3, Chromat Telemetry* and *Section K.4, Composition Processing, Composition Processing*. Note, these processing steps are user selectable on the Station Gas Composition and Stream Gas Composition displays in PCSetup.

### K.2.2 KEYPAD Mode

In KEYPAD mode, you can enter a fixed gas composition with processing and checks optionally applied.

In KEYPAD mode, the Station or Stream keypad set (KEYPAD MOLES) is processed to become the in-use gas composition (CHR SLCT MOLES).

The keypad set is validated against high and low limits before becoming the in-use set. Details of this are given in *Section K.4.2, High/Low Limits*.

It is possible to have an optional user acceptance step before a new keypad set is validated. This allows the user to confirm that the correct values have been entered before they become in-use.

The validated keypad set can be normalised to give a component total of 100% before it becomes the in-use set.

Acceptance and normalisation are configured using Acceptance Type (set on the Station Gas Composition and Stream Gas Composition screens), in PCSetup. Details of normalisation are given in *Section K.4.4, Normalisation*. The following options are available:

- ACC/COPY**
  - Keypad set components can be changed by the user but will not be validated to become the in-use composition until the user sets the Acceptance Command.
  - No normalisation is carried out on the validated keypad set before it is transferred to the in-use composition.
- ACC/NORM**
  - Keypad set components can be changed by the user but will not be validated to become the in-use composition until the user sets the Acceptance Command.
  - Normalisation is carried out on the validated keypad set before it is transferred to the in-use composition.
- AUTO/NORM**
  - Keypad set components can be changed by the user and will be validated to become the in-use composition without the use of the Acceptance Command.
  - Normalisation is carried out on the validated keypad set before it is transferred to the in-use composition.

If ACC/COPY option is used it is important that the values written to the keypad set sum to 100%, otherwise calculations that use the in-use gas composition as an input may give errors.

### K.2.3 DOWNLOAD Mode

DOWNLOAD mode is intended to allow a gas composition to be downloaded to the flow computer from a supervisory system via a Modbus link.

In DOWNLOAD mode, the Station or Stream download set (CHR DLOAD MOLES) becomes the in-use gas composition (CHR SLCT MOLES).

The download set is monitored by the S600+ and if a change in any component is seen, the download set is validated against high and low limits before becoming the in-use set. Details of this are given in *Section K.4.2, High/Low Limits*.

No acceptance step is available before a new download set is validated.

No normalisation is carried out on the validated download set before it becomes the in-use set.

With no acceptance step or normalisation, it is important that the values written to the download set sum to 100%, otherwise calculations that use the in-use gas composition as an input may give errors.

A timeout may be applied to the download set. The download set component values must be updated within the entered D/L TIMEOUT value. More details are given in *Sections K.2.5, Mode Selection* and *Section K.4.9, Timeouts*.

It is possible to use a Download Flag with the download set. This should be added to the supervisory Modbus Map along with the download set. If the Download Flag is set to 1 then the download set is validated, irrespective of whether any component has changed. Once validated the Download Flag is reset to 0. This must be configured using System Editor: details are given in *Section K.11.5 Download Flag*.

## K.2.4 USER Mode

USER mode is intended to allow a fixed gas composition to be selected for the purpose of calculation testing. If used for this purpose, it may be desirable to have the user gas components on the flow computer displays as read-only or with a restricted security level.

In USER mode, the Station or Stream user set (CHR USER MOLES) becomes the in-use gas composition (CHR SLCT MOLES).

The user set is monitored by the S600+ and if a change in any component is seen, the user set is validated against high and low limits before becoming the in-use set. Details of this are given in *Section K.4.2, High/Low Limits*.

No acceptance step is available before a new user set is validated.

No normalisation is carried out on the validated user set before it becomes the in-use set.

With no acceptance step or normalisation, it is important that the values written to the user set sum to 100%, otherwise calculations that use the in-use gas composition as an input may give errors.

## K.2.5 Mode Selection

This section describes mode selection for the gas composition, including manual mode selection by the operator and automatic mode switching to KEYPAD-FAIL mode, as well as the option to revert to the last good chromat set.

**Manual Mode Selection** Modes can be selected manually by the user using MOLE SELECT on the flow computer display.

- MOLE SELECT cannot be placed into CHROMAT mode:
  - If no set has yet been received from the GC.  
OR
  - If the latest set read from the GC fails any of the configured validation checks described in *Section K.4, Composition Processing*.  
OR

- If no new analysis data has been received from the GC within the Analysis Timeout time (applies to certain GC types, see *Section K.4.9, Timeouts*).

OR

- If communications to the GC have failed.
- MOLE SELECT cannot be placed into KEYPAD, DOWNLOAD or USER mode:
  - If the relevant set fails the high and low limit validation checks described in *Section K.4.2, High/Low Limits*.

**KEYPAD-FAIL Mode** Under the following conditions, the flow computer will automatically switch the gas composition mode to KEYPAD-FAIL and the validated keypad set will become the in-use set. Note, if the keypad set cannot be validated then the gas composition will remain in its current mode and the in-use set will not update.

- In CHROMAT mode (If the 'Revert to Last Good after Failure' option is not set in PCSetup):
    - If the latest set read from the GC fails any of the configured validation checks described in *Section K.4, Composition Processing*.
- OR
- If no new analysis data has been received from the GC within the Analysis Timeout time (applies to certain GC types, see *Section K.4.9, Timeouts*).
- OR
- If communications to the GC have failed.
- In DOWNLOAD mode:
  - If the latest download set fails the high and low limit validation checks described in *Section K.4.2, High/Low Limits*.
- In USER mod:
  - If the latest user set fails the high and low limit validation checks described in *Section K.4.2, High/Low Limits*, the mode will remain USER, but the in-use set will not update.

**Revert to Last Good** In CHROMAT mode it is possible for the flow computer to use the last good gas composition set read from the GC, if the 'Revert to Last Good after Failure' option is set in PCSetup, and a good set has previously been read from the GC. This will occur in the following conditions:

- If the latest set read from the GC fails any of the configured validation checks described in *Section K.4, Composition Processing*.

OR

- If no new analysis data has been received from the GC within the Analysis Timeout time (applies to certain GC types, see *Section K.4.9, Timeouts*).

OR

- If communications to the GC have failed.

If the 'Revert to Last Good after Failure' option is set in PCSetup and no good set has previously been read from the GC, the switch to KEYPAD-FAIL mode will be made, as described above.

**Keypad Fail with Recovery**

It is possible to configure the gas composition mode handling to automatically switch back from KEYPAD-FAIL mode to CHROMAT mode when a new valid chromat set is read from the GC. This requires the use of System Editor and is described in *Section K.11.4, Mole Select – Keypad Fail Switchback*.

### K.3 Chromat Telemetry

---

When Type (configured on the Station Gas Composition and Stream Gas Composition screens) is set to CHROMAT A, CHROMAT B or CHROMAT AUTO, the Modbus master process interfaces to the GC as instructed by the chromatograph data handling software. The handling software triggers a controlled, sequential series of polls, enabling the orderly acquisition of analysis report data. This handling is controlled by the CHROM TELEM calculation table and the poll sequences for each GC type are detailed below.

#### K.3.1 Telemetry Inputs

The following objects are inputs to the CHROM TELEM calculation table.

<b>Telemetry Mode (MODE)</b>	Not used
<b>Chromat Type (TYPE)</b>	Type of GC (2551 EURO, 2350 EURO, 2350 USA, 2251 USA, GENERIC, SIEMENS)
<b>Address (SLAVE ADDR)</b>	This is the slave address of the GC. (Not always used, see <i>Section K.1, Station/Stream Combinations</i> .)
<b>Stream (CYCLE STREAM)</b>	This is the GC Analysis stream that the S600+ will accept the composition data from (0 = accept all streams).
<b>Analysis Timeout (ANALYSIS T/O)</b>	This is the time (in seconds) during which the S600+ expects to receive a new composition from the GC.
<b>Mole Order</b>	Used to order the Raw Mole % read from the chromat. Used as an input when the chromat type is set to SIEMENS or GENERIC. Used as an output when the chromat type is set to EURO or USA, where order is dictated by the Component Codes read from chromat. See <i>Section K.4.1, Component Ordering</i> .

<b>Poll Delay</b>	Time interval in seconds between triggering of Modbus polls to the chromat. (Not available in PCSetup)
<b>Matched Reset Delay (RESET DELAY 1)</b>	The delay (seconds) in resetting the new data flag, after it has been set by the chromat, when the stream indicated by the chromat matches the CYCLE STREAM configured in the flow computer. (Not available in PCSetup)
<b>Unmatched Reset Delay (RESET DELAY 2)</b>	The delay (seconds) in resetting the new data flag, after it has been set by the chromat, when the stream indicated by the chromat <b>does not</b> match the CYCLE STREAM configured in the flow computer. <b>Note:</b> If this value is set to zero, then the sequence does not reset the non-matched new data flag. (Not available in PCSetup)
<b>Slave Address</b>	Array of Modbus slave addresses for GCs. Used by Modbus map file as Slave Address Object.
<b>Slave Status</b>	Field of array of Modbus slave statuses for GCs. Used by Modbus map file as Slave Status Object.

### K.3.2 Telemetry Outputs

The following objects are outputs from the CHROM TELEM calculation table.

<b>Telemetry Stage (TELEM STAGE)</b>	The stage in the telemetry sequence. One of the following values:
<b>0</b>	POLL IDLE – Idle
<b>1</b>	POLL STAT PRE-REP – Poll delay, then poll for status data
<b>2</b>	WAIT STAT PRE-REP – Wait for status data
<b>3</b>	POLL CODES – Poll delay, then poll for component codes
<b>4</b>	WAIT CODES – Wait for component codes
<b>5</b>	POLL MOLES – Poll delay, then poll for mole percentages
<b>6</b>	WAIT MOLES – Wait for mole percentage data
<b>7</b>	POLL CV – Poll delay, then poll for auxiliary data
<b>8</b>	WAIT CV – Wait for auxiliary data
<b>9</b>	FORCE IMMED RESET – Reset new data flag (reserved)
<b>10</b>	POSTREP POLL STAT – Poll delay, then poll again for status data

	<b>11</b>	POST REP WAIT STAT – Wait for status data
	<b>12</b>	PROCESS DATA – Process analysis data
	<b>13</b>	POST REP DELAY – Delay after a matched report, then poll again for status data
	<b>14</b>	PRE-RESET WAIT STAT – Wait for new status data
	<b>15</b>	RESET REPORT – Poll delay, then reset new data flag
	<b>16</b>	WAIT RESET – Wait for new data flag reset
	<b>17</b>	NONE MTCH DELAY – Delay after unmatched report, then poll again for status data
	<b>18</b>	NONE MTCH WAIT STAT – Wait for status data
	<b>19</b>	NONE MTCH RESET REP – Poll delay, then reset new data flag
	<b>20</b>	NONE MTCH WAIT RESET – Wait for new data flag reset
<b>Status Request Flag 1 (TELEM REQ.STAT 1)</b>		Trigger for Modbus master GC Status Data poll
<b>Moles Request Flag (TELEM REQ.MOLES)</b>		Trigger for Modbus master GC Composition Mole % poll
<b>CV (etc.) Request Flag (TELEM REQ.CV)</b>		Trigger for Modbus master GC Auxiliary Data poll
<b>New Data Reset Flag (TELEM REQ.RESET)</b>		Trigger for Modbus master GC reset New Data Flag poll
<b>Current Report Status (CURR REPORT STAT)</b>		Updated based on the validation status of the last result for the GC. Values:
	<b>0</b>	No result (for the configured GC stream) has been received since a flow computer cold start
	<b>1</b>	Result is for the configured GC stream and has passed the configured processing steps (see <i>Section K.4, Composition Processing</i> )
	<b>2</b>	Result is for the configured GC stream but has not passed the configured processing steps (see <i>Section K.4, Composition Processing</i> )
	<b>3</b>	A new result has not been received within the timeout period (see <i>Section K.4.9, Timeouts</i> )
<b>Good Report Latch (PREV REPORT STAT)</b>		Latched based on the validation status of results from the GC Values:
	<b>0</b>	No result (for the configured GC stream) has been received since a flow computer cold start
	<b>1</b>	A result has been received for the configured GC stream and has passed the configured processing steps (see <i>Section K.4, Composition Processing</i> )



<b>Raw Status Data</b>	GC Status Data from Modbus poll
<b>Raw Mole % (RAW MOLE PCNTS)</b>	GC Composition Mole % from Modbus poll
<b>Raw CV (etc.) (RAW MISC DATA)</b>	GC Auxiliary Data from Modbus poll
<b>Adjusted Moles (CURR ADJ.MOLES)</b>	Ordered GC Composition Mole % with normalisation, splits applied, additional added but no limit or alarm checks
<b>Good Moles (GOOD ADJ.MOLES)</b>	Ordered GC Composition Mole % with normalisation, splits applied, additional added, when limit and alarm checks are passed
<b>Alarm Registers</b>	Array used to indicate the alarm status of the GC handling. Meaning if field indicating 1:
<b>Field 01</b>	System Alarm (RX Fail)
<b>Field 02</b>	Configuration Alarm (Splits Error, Additional Error)
<b>Field 03</b>	Critical Alarm (indicated by GC)
<b>Field 04</b>	Non-Critical Alarm (indicated by GC)
<b>Field 05</b>	Low Limit Alarm (components 1-16)
<b>Field 06</b>	Low Limit Alarm (components 17-32)
<b>Field 07</b>	High Limit Alarm (components 1-16)
<b>Field 08</b>	High Limit Alarm (components 17-32)
<b>Field 09</b>	Deviation Alarm (components 1-16)
<b>Field 10</b>	Deviation Alarm (components 17-32)
<b>Codes Request Flag (TELEM REQ.CODES)</b>	Trigger for Modbus master GC Component Codes poll
<b>Component Codes</b>	GC Component Codes from Modbus poll
<b>Ordered Moles (GOOD ORDER MOLES)</b>	Ordered GC Composition Mole % without normalisation, splits applied or additional added, when limit and alarm checks have passed
<b>Analysis Time Stamp (LAST ANALYSIS AT)</b>	Time of the last good analysis from the GC
<b>Report Flags</b>	Used to generate CHROM TELEM report
<b>Status Request Flag 2 (TELEM REQ.STAT 2)</b>	Trigger for Modbus master GC Status Data poll (used instead of Status Request Flag 1 for Chromat Type = USA)

### K.3.3 EURO Stages

The GC telemetry sequence for the chromat types 2551 EURO and 2350 EURO is described below. The main features of the sequence are:

- The GC is constantly polled for Status Data.
- If the New Data Flag is set **and** the Analysis/Calibration Flag is indicating Analysis **and** the last analysed GC stream matches the S600+ stream, then further polls will be issued for analysis data.

- The analysis data is processed and validated (see *Section K.4, Composition Processing*). Components are ordered using the Component Codes read from the GC.
- The New Data Flag is reset.

---

**Note:**

- The chromatograph data handling for 2551 and 2350 Euro chromatograph types is identical.
  - In the following description, the time-out period for the GC to respond is dictated by the Timeout and Retry Limit values configured in the chromat Modbus map Properties.
- 

*Table K-2. Euro Stages*

<b>Stage</b>	<b>Description</b>
<b>1</b> POLL IDLE	Set next stage to <b>POLL STAT PRE-REP.</b>
<b>2</b> POLL STAT PRE-REP	Wait Poll Delay, then set the flag for the Modbus master process to poll for status data at addresses 3041 to 3061 (CHR REQ. STAT 1). Set next stage to <b>WAIT STAT PRE-REP.</b>

Stage	Description
3 WAIT STAT PRE-REP	<p>Wait up to the time-out period for the GC to respond. If no reply has been received then set the CHROM TELEM RX FAIL alarm and set the stage to <b>POLL IDLE</b>.</p> <p>If a reply <b>has</b> been received <b>and</b> the New Data Flag is set <b>and</b> the Analysis/Calibration Flag is indicating Analysis <b>and</b> the last analysed GC stream matches the S600+ stream*, then set the stage to <b>POLL CODES</b>.</p> <p>If a reply <b>has</b> been received <b>and</b> the New Data Flag is set <b>and</b> the Analysis/Calibration Flag is indicating Analysis <b>and</b> the last analysed GC stream <b>does not</b> match the S600+ stream* <b>and</b> the delay for non-matched reset is non-zero, then set the stage to <b>NONE MTCH DELAY</b>.</p> <p>If a reply <b>has</b> been received <b>and</b> the New Data Flag is set <b>and</b> the Analysis/Calibration Flag is indicating Analysis <b>and</b> the last analysed GC stream <b>does not</b> match the S600+ stream* <b>and</b> the delay for non-matched reset is zero, then set the stage to <b>POLL IDLE</b>.</p> <p>If a reply <b>has</b> been received <b>and</b> the New Data Flag is set <b>and</b> the Analysis/Calibration Flag is indicating Calibration, then set the stage to <b>NONE MTCH RESET REP</b>.</p> <p>If a reply has been received and New Data Flag is clear, then set the stage to <b>POLL IDLE</b>.</p> <p>* For Station handling, S600+ stream = 0 will accept all GC streams. For stream handling, S600+ stream must match GC stream.</p>
4 POLL CODES	<p>Wait ~1 second, then flag the Modbus master to poll for the component codes at addresses 3001 to 3016 (CHR REQ. CODES) and set the next stage to <b>WAIT CODES</b>.</p>
5 WAIT CODES	<p>Wait up to the time-out period for the GC to respond. If no reply has been received, then set the CHROM TELEM RX FAIL alarm and set the stage to <b>POLL IDLE</b>.</p> <p>If a reply has been received, then set the stage to <b>POLL MOLES</b>.</p>
6 POLL MOLES	<p>Wait ~1 second, then flag the Modbus master to poll for the mole percentage results at addresses 7000 to 7016 (CHR REQ. MOLE) and set the next stage to <b>WAIT MOLES</b>.</p>

Stage	Description
7 WAIT MOLES	<p>Wait up to the time-out period for the GC to respond. If no reply has been received, then set the CHROM TELEM RX FAIL alarm and set the stage to <b>POLL IDLE</b>.</p> <p>If a reply has been received, then set the stage to <b>POLL CV</b>.</p>
8 POLL CV	<p>Wait ~1 second, then set the flag for the Modbus master to poll for CV and other auxiliary data at addresses 7033 to 7039 and 7087 (CHR REQ. CV). Set the next stage to <b>WAIT CV</b>.</p>
9 WAIT CV	<p>Wait up to the time-out period for the GC to respond. If no reply has been received, then set the CHROM TELEM RX FAIL alarm and set the stage to <b>POLL IDLE</b>.</p> <p>If a reply has been received, then set the next stage to <b>POST REP POLL STAT</b>.</p>
10 FORCE IMMEDIATE RESET	<i>Currently reserved</i>
11 POST REP POLL STAT	<p>Wait ~1 second, then set the flag for the Modbus master to poll for status data at addresses 3041 to 3061 (CHR REQ. STAT 1).</p> <p>Set next stage to <b>POST REP WAIT STAT</b>.</p>
12 POST REP WAIT STAT	<p>Wait up to the time-out period for the GC to respond. If no reply has been received, then set the CHROM TELEM RX FAIL alarm and set the stage to <b>POLL IDLE</b>.</p> <p>If a reply <b>has</b> been received <b>and</b> the Analysis/Calibration Flag is indicating Analysis <b>and</b> the last analysed GC stream matches the S600+ stream, then set the stage to <b>PROCESS DATA</b>.</p> <p>Otherwise, set the next stage to <b>POLL IDLE</b>.</p>

Stage	Description
13 PROCESS DATA	<ol style="list-style-type: none"> <li>1. Reorder the received raw mole percentages into S600+ internal order using the received component codes, starting at 100.</li> <li>2. If configured to do so, check low/high and deviation limits.</li> <li>3. If configured to do so, normalise the reordered mole percentage set.</li> <li>4. If enabled, apply the additional.</li> <li>5. If enabled (or dictated by component code), apply splits to CX+ component.</li> <li>6. Copy the processed mole percentage set into the CHR ADJ. MOLES set.</li> <li>7. If enabled, perform critical alarm checks.</li> <li>8. If enabled, perform non-critical alarm checks.</li> <li>9. If there are no limit, critical, non-critical or deviation alarms, then mark the analysis as good, copy the fully processed mole percentage set into CHR GOOD MOLES, copy the reordered mole percentages from Step 1 into CHR ORDERED MOLES, update auxiliary data, and update the Last Analysis Time.</li> </ol> <p>Set next stage to <b>POST REP DELAY</b>.</p>
14 POST REP DELAY	<p>Wait up to the specified time (delay for matched report reset, CHR RF DELAY1), then set the flag for the Modbus master to poll for status data at addresses 3041 to 3061 (CHR REQ. STAT 1). Set next stage to <b>PRE-RESET WAIT STAT</b>.</p>
15 PRE-RESET WAIT STAT	<p>Wait up to the time-out period for the GC to respond. If no reply has been received, then set the CHROM TELEM RX FAIL alarm and set the stage to <b>POLL IDLE</b>.</p> <p>If a reply <b>has</b> been received <b>and</b> the New Data Flag is set <b>and</b> the Analysis/Calibration Flag is indicating Analysis <b>and</b> the last analysed GC stream matches the S600+ stream, then set the stage to <b>RESET REPORT</b>.</p> <p>Otherwise, set the next stage to <b>POLL IDLE</b>.</p>
16 RESET REPORT	<p>Wait ~1 second, then set the flag for the Modbus master process to reset the New Data Flag at address 3058 (CHR REQ. RESET). Set the next stage to <b>WAIT RESET</b>.</p>

Stage	Description
17 WAIT RESET	<p>Wait up to the time-out period for the GC to respond. If no reply has been received, then set the CHROM TELEM RX FAIL alarm and set the stage to <b>POLL IDLE</b>.</p> <p>If a reply <b>has</b> been received, then set the next stage to <b>POLL IDLE</b>. This is the last stage of the normal data acquisition cycle.</p>
18 NONE MTCH DELAY	<p>Wait up to the specified time (delay for non-matched report reset, CHR RF DELAY2), then set the flag for the Modbus master to poll for status data at addresses 3041 to 3061 (CHR REQ. STAT 1). Set next stage to <b>NONE MTCH WAIT STAT</b>.</p>
19 NONE MTCH WAIT STAT	<p>Wait up to the time-out period for the GC to respond. If no reply has been received, then set the CHROM TELEM RX FAIL alarm and set the stage to <b>POLL IDLE</b>.</p> <p>If a reply <b>has</b> been received <b>and</b> the New Data Flag is set <b>and</b> the Analysis/Calibration Flag is indicating Analysis <b>and</b> the last analysed GC stream <b>does not</b> match the S600+ stream, then set the stage to <b>NONE MTCH RESET REP</b>.</p> <p>Otherwise, set the next stage to <b>POLL IDLE</b>.</p>
20 NONE MTCH RESET REP	<p>Wait ~1 second, then set the flag for the Modbus master process to reset the New Data Flag at address 3058 (CHR REQ. RESET). Set the next stage to <b>NONE MTCH WAIT RESET</b>.</p>
21 NONE MTCH WAIT RESET	<p>Wait up to the time-out period for the GC to respond. If no reply has been received, then set the CHROM TELEM RX FAIL alarm and set the stage to <b>POLL IDLE</b>.</p> <p>If a reply <b>has</b> been received, then set the next stage to <b>POLL IDLE</b>. This is the last stage of the cycle where a new report has been flagged by is not assigned to this S600+ station or stream.</p>

### K.3.4 USA Stages

The GC telemetry sequence for the chromat types 2251 USA and 2350 USA is described below. The main features of the sequence are:

- The GC is constantly polled for Status Data. The Address Range polled is different from the EURO types.
- If the Last Analysis Start Time Minute has changed **and** the Analysis/Calibration Flag is indicating Analysis **and** the last

analysed GC stream matches the S600+ stream, then further polls will be issued for analysis data.

- The analysis data is processed and validated (see *Section K.4, Composition Processing*). Components are ordered using the Component Codes read from the GC.

---

**Note:**

- The chromatograph data handling for 2251 and 2350 USA chromatograph is identical.
  - In the following description, the time-out period for the GC to respond is dictated by the Timeout and Retry Limit values configured in the chromat Modbus map Properties.
- 

*Table K-3. USA Stages*

Stage	Description
1 POLL IDLE	Set next stage to <b>POLL STAT PRE-REP</b> . Then set the flag for the Modbus master process to poll for status data at addresses 3033 to 3059 (CHR REQ. STAT 2).
2 POLL STAT PRE-REP	<p>Wait up to the time-out period for the GC to respond. If no reply has been received then set the flag for the Modbus master process to poll for status data at addresses 3033 to 3059 (CHR REQ. STAT 2). If no reply is received after 4 attempts set the CHROM TELEM RX FAIL alarm and set the stage to <b>POLL IDLE</b>.</p> <p>If a reply <b>has</b> been received <b>and</b> the Last Analysis Start Time Minute has changed <b>and</b> the Analysis/Calibration Flag is indicating Analysis <b>and</b> the last analysed GC stream matches the S600+ stream*, then flag the Modbus master to poll for the component codes at addresses 3001 to 3016 (CHR REQ. CODES) and set the next stage to <b>POLL CODES</b>.</p> <p>* For Station handling, S600+ stream = 0 will accept all GC streams. For stream handling, S600+ stream must match GC stream.</p>

---

Stage	Description
3 POLL CODES	<p>Wait up to the time-out period for the GC to respond. If no reply has been received then set the flag for the Modbus master process to poll for the component codes at addresses 3001 to 3016 (CHR REQ. CODES). If no reply is received after 4 attempts set the CHROM TELEM RX FAIL alarm and set the stage to <b>POLL IDLE</b>.</p> <p>If a reply has been received, then flag the Modbus master to poll for the mole percentage results at addresses 7000 to 7016 (CHR REQ. MOLE) and set the next stage to <b>POLL MOLES</b>.</p>
4 POLL MOLES	<p>Wait up to the time-out period for the GC to respond. If no reply has been received then set the flag for the Modbus master process to poll for mole percentage results at addresses 7000 to 7016 (CHR REQ. MOLE). If no reply is received after 4 attempts set the CHROM TELEM RX FAIL alarm and set the stage to <b>POLL IDLE</b>.</p> <p>If a reply has been received, then flag the Modbus master to poll for the CV and other auxiliary data at addresses 7033 to 7039 and 7087 (CHR REQ. CV) and set the next stage to <b>POLL CV</b>.</p>
5 POLL CV	<p>Wait up to the time-out period for the GC to respond. If no reply has been received then set the flag for the Modbus master process to poll for CV and other auxiliary data at addresses 7033 to 7039 and 7087 (CHR REQ. CV). If no reply is received after 4 attempts set the CHROM TELEM RX FAIL alarm and set the stage to <b>POLL IDLE</b>.</p> <p>If a reply has been received, then flag the Modbus master to poll for the status data at addresses 3033 to 3059 (CHR REQ. STAT 2) and set the next stage to <b>POST REP POLL STAT</b>.</p>



Stage	Description
6 POST REP POLL STAT	<p>Wait up to the time-out period for the GC to respond. If no reply has been received then set the flag for the Modbus master process to poll for status data at addresses 3033 to 3059 (CHR REQ. STAT 2). If no reply is received after 4 attempts set the CHROM TELEM RX FAIL alarm and set the stage to <b>POLL IDLE</b>.</p> <p>If a reply <b>has</b> been received <b>and</b> the Last Analysis Start Time Minute has not changed, then set the stage to <b>PROCESS DATA</b>.</p> <p>If a reply <b>has</b> been received <b>and</b> the Last Analysis Start Time Minute has changed, then set the stage to <b>POLL IDLE</b>.</p>
7 PROCESS DATA	<ol style="list-style-type: none"> <li>1. Reorder the received raw mole percentages into S600+ internal order using the received component codes, starting at 100. If received component code is less than 100, add 100 before processing.*</li> <li>2. If configured to do so, check low/high and deviation limits.</li> <li>3. If configured to do so, normalise the reordered mole percentage set.</li> <li>4. If enabled, apply the additional.</li> <li>5. If enabled (or dictated by component code), apply splits to CX+ component.</li> <li>6. Copy the processed mole percentage set into the CHR ADJ. MOLES set.</li> <li>7. If enabled, perform critical alarm checks.</li> <li>8. If enabled, perform non-critical alarm checks.</li> <li>9. If there are no limit, critical, non-critical or deviation alarms, then mark the analysis as good, copy the fully processed mole percentage set into CHR GOOD MOLES, copy the reordered mole percentages from Step 1 into CHR ORDERED MOLES, update the RD and CV, and update the Last Analysis Time.</li> </ol> <p>Set next stage to <b>POLL IDLE</b>.</p> <p>* Note: USA option is incompatible with using component code 0 for unused components in the GC.</p>

### K.3.5 Siemens Stages

The GC telemetry sequence for the chromat type SIEMENS is described below. The main features of the sequence are:

- The GC is alternately polled for Status Data and New Data Flag.
- If the New Data Flag is set, then further polls will be issued for analysis data.
- The analysis data is processed and validated (see *Section K.4, Composition Processing*). Components are ordered using the Mole Order entered by the user.

---

**Note:**

- Config600 does not generate the correct Modbus map file for the Siemens type GC. The data handling module sets flags to poll Modbus registers. The Modbus map must be configured by the user in Modbus Editor. Refer to *How To 197*.
  - In the following description, the time-out period for the GC to respond is dictated by the Timeout and Retry Limit values configured in the chromat Modbus map Properties.
- 

*Table K-4. Siemens Stages*

Stage	Description
1 POLL IDLE	Alternate setting the flags for the Modbus master process to poll the GC for status data (CHR REQ. STAT 1) and New Data Flag (CHR REQ. CODES). Then set next stage to <b>POLL STAT PRE-REP</b> .
2 POLL STAT PRE-REP	<p>Wait up to the time-out period for the GC to respond. If no reply is received set the CHROM TELEM RX FAIL alarm and set the stage to <b>POLL IDLE</b>.</p> <p>When polling for New Data Flag:</p> <p>If a reply <b>has</b> been received <b>and</b> the New Data Flag has changed to <math>\geq 1</math>, then flag the Modbus master to poll for the mole percentage results, CV and other auxiliary data (CHR REQ. MOLE) and set the next stage to <b>POLL MOLES</b>.</p> <p>If a reply <b>has</b> been received <b>and</b> the New Data Flag has not changed, then set the next stage to <b>POLL IDLE</b>.</p> <p>When polling for status data:</p> <p>If a reply <b>has</b> been received <b>and</b> Analyzer Status value <math>&lt; 600</math>, then raise CHROM TELEM CRITICAL alarm and set the next stage to <b>POLL IDLE</b>.</p> <p>If a reply <b>has</b> been received <b>and</b> Analyzer Status value <math>\geq 600</math>, then set the next stage to <b>POLL IDLE</b>.</p>

---

Stage	Description
3 POLL MOLES	<p>Wait up to the time-out period for the GC to respond. If no reply is received set the CHROM TELEM RX FAIL alarm and set the stage to <b>POLL IDLE</b>.</p> <p>If a reply has been received, then set the next stage to <b>PROCESS DATA</b>.</p>
4 PROCESS DATA	<p>If the last analysed GC stream matches the S600+ stream*, then process the received GC data:</p> <ol style="list-style-type: none"> <li>1. Reorder the received raw mole percentages into S600+ internal order using the Mole Order entered in S600+.</li> <li>2. If configured to do so, check low/high and deviation limits.</li> <li>3. If configured to do so, normalise the reordered mole percentage set.</li> <li>4. If enabled, apply the additionals.</li> <li>5. If enabled (or dictated by component code), apply splits to CX+ component.</li> <li>6. Copy the processed mole percentage set into the CHR ADJ. MOLES set.</li> <li>7. If enabled, perform critical alarm checks.</li> <li>8. If there are no limit, critical, or deviation alarms, then mark the analysis as good, copy the fully processed mole percentage set into CHR GOOD MOLES, copy the reordered mole percentages from Step 1 into CHR ORDERED MOLES, update the auxiliary data, and update the Last Analysis Time.</li> </ol> <p>Set next stage to <b>POLL IDLE</b>.</p> <p>* For Station handling, S600+ stream = 0 will accept all GC streams. For stream handling, S600+ stream must match GC stream.</p>

### K.3.6 Generic Stages

The GC telemetry sequence for the chromat type GENERIC is described below. The main features of the sequence are:

- The GC is constantly polled for Status Data.
- If the New Data Flag is set, then further polls will be issued for analysis data.
- The New Data Flag is reset.
- The analysis data is processed and validated (see *Section K.4, Composition Processing*). Components are ordered using the Mole Order entered by the user.

**Note:**

- By default, Config600 will use the 2551/2350 EURO Modbus map file for the Generic type GC. If a different map is required, it must be configured by the user in Modbus Editor. Refer to *How To 158*.
  - In the following description, the time-out period for the GC to respond is dictated by the Timeout and Retry Limit values configured in the chromat Modbus map Properties.
- 

*Table K-5. Generic Stages*

<b>Stage</b>	<b>Description</b>
1 POLL IDLE	<p>Set the flag for the Modbus master process to poll for status data (CHR REQ. STAT 1).</p> <p>Set next stage to <b>POLL STAT PRE-REP</b>.</p>
2 POLL STAT PRE-REP	<p>Wait up to the time-out period for the GC to respond. If no reply has been received then set the RX FAIL alarm and set the stage to <b>POLL IDLE</b>.</p> <p>If a reply <b>has</b> been received <b>and</b> the New Data Flag is set, then flag the Modbus master to poll for the mole percentage (CHR REQ. MOLE) and set the stage to <b>POLL MOLES</b>.</p> <p>If a reply <b>has</b> been received <b>and</b> the New Data Flag is not set, then set the stage to <b>POLL IDLE</b>.</p>
4 POLL MOLES	<p>Wait up to the time-out period for the GC to respond. If no reply is received set the RX FAIL alarm and set the stage to <b>POLL IDLE</b>.</p> <p>If a reply has been received, then flag the Modbus master to poll for the CV and other auxiliary data (CHR REQ. CV) and set the next stage to <b>POLL CV</b>.</p>
5 POLL CV	<p>Wait up to the time-out period for the GC to respond. If no reply has been received then set the RX FAIL alarm and set the stage to <b>POLL IDLE</b>.</p> <p>If a reply has been received, then flag the Modbus master to reset the New Data Flag at address 3058 (CHR REQ. RESET) and set the next stage to <b>FORCE IMMED RESET</b>.</p>
6 FORCE IMMED RESET	<p>Wait up to the time-out period for the GC to respond. If no reply has been received then set the RX FAIL alarm and set the stage to <b>PROCESS DATA</b>.</p> <p>If a reply has been received then set the stage to <b>PROCESS DATA</b>.</p>

---

Stage	Description
7 PROCESS DATA	<p>If the last analysed GC stream matches the S600+ stream*, then process the received GC data:</p> <ol style="list-style-type: none"> <li>1. Reorder the received raw mole percentages into S600+ internal order using the Mole Order entered in S600+.</li> <li>2. If configured to do so, check low/high and deviation limits.</li> <li>3. If configured to do so, normalise the reordered mole percentage set.</li> <li>4. If enabled, apply the additional.</li> <li>5. If enabled (or dictated by component code), apply splits to CX+ component.</li> <li>6. Copy the processed mole percentage set into the CHR ADJ. MOLES set.</li> <li>7. If enabled, perform critical alarm checks.</li> <li>8. If enabled, perform non-critical alarm checks.</li> <li>9. If there are no limit, critical, non-critical or deviation alarms, then mark the analysis as good, copy the fully processed mole percentage set into CHR GOOD MOLES, copy the reordered mole percentages from Step 1 into CHR ORDERED MOLES, update the auxiliary data, and update the Last Analysis Time.</li> </ol> <p>Set next stage to <b>POLL IDLE</b>.</p> <p>* For Station handling, S600+ stream = 0 will accept all GC streams. For stream handling, S600+ stream must match GC stream.</p>

## K.4 Composition Processing

This section details how the raw composition values are processed, and the checks performed before the data can be copied to the CHR SELECT MOLES and used in subsequent calculations.

### K.4.1 Component Ordering

Component ordering is carried out on the raw composition values read from the chromat. The chromat logic orders the raw values from the Modbus map, to give the correct component values in the flow computer.

**EURO & USA** For the EURO and USA chromat types, the raw values read from the chromat are ordered according to the component codes contained in the CHR CODES array. This array would normally be read from the chromat using addresses 3001-3016 on the Modbus map. The table of recognised component codes is shown in *Table K-6. Component Codes*.

The field of the CHR CODES array gives the component code of the raw component percentage in the corresponding field of the CHR RAW MOLES array, normally read from the chromat using addresses 7001-7016 on the Modbus map. E.g.:

- If CHR CODES **FIELD 01** = 100, the percentage value at CHR RAW MOLES **FIELD 01** will be assigned to Methane in the flow computer component set.
- If CHR CODES **FIELD 05** = 114, the percentage value at CHR RAW MOLES **FIELD 05** will be assigned to Nitrogen in the flow computer component set.

---

**Note:**

- Any value of component code not included in *Table K-6. Component Codes* will result in the corresponding field of CHR RAW MOLES being ignored.
  - For the USA option, if the value of component code read is less than 100, the S600+ will add 100 before applying the component codes in *Table K-6. Component Codes*. This means that component codes less than 100 must not be used for unused component addresses.
- 

*Table K-6. Component Codes*

Code	Component	Code	Component
100	METHANE	114	NITROGEN
101	ETHANE	115	CO
102	PROPANE	116	OXYGEN
103	I_BUTANE	117	CO2
104	N_BUTANE	119	NONANE
105	I_PENTANE	120	OCTANE
106	N_PENTANE	125	DECANE
107	NEO_PENTANE	139	HEXANE
108	C6_PLUS (47/35/17)	140	H2S
109	C6_PLUS (50/50/0)	144	H2O
110	C6_PLUS (50/25/25)	145	HEPTANE
111	C6_PLUS (57/28/14)	146	ARGON
112	HYDROGEN	150	CX_PLUS (C9)
113	HELIUM	151	CX_PLUS (C8)
		152	CX_PLUS (C7)

---

**Note:** Before splits are applied, C6+ codes are assigned to the C6\_PLUS field, C7+/C8+/C9+ codes are assigned to the CX\_PLUS field.

---

**SIEMENS & GENERIC** For the SIEMENS and GENERIC chromat type, the order of components is defined by the values entered in the MOLE ORDER array.

The value entered for each component corresponds to its position in the CHR RAW MOLES array on the Modbus map. If **1** is entered in the MOLE ORDER field for Methane, the value of CHR RAW MOLES, **FIELD 01** will be assigned to Methane. If **14** is entered for CO2, the value of CHR RAW MOLES, **FIELD 14** will be assigned to CO2.

## K.4.2 High/Low Limits

The various gas composition sets are verified against high and low limits when they change in value.

### KEYPAD, DOWNLOAD & USER

If the Check Limits option is enabled:

- Check all components, plus the calculated component total, against the corresponding high and low limits, unless the limit value equals 0.

If the Check Limits option is not enabled:

- Check the calculated component total against the default high limit (102%) and low limit (98%).

If the check fails, reject the new composition set and raise the relevant alarm, if enabled:

- For the Keypad set, MOLE SELECT K\_COMP.
- For the Download set, MOLE SELECT DL COMP.
- For the User set, MOLE SELECT USER COMP

**CHROMAT** When a new analysis becomes available from the chromat, the ordered set (before normalisation, splits or additional are applied) is verified against high and low limits.

If the Check Limits option is enabled:

- Check all components, plus the calculated component total, against the corresponding high and low limits, unless the limit value equals 0.
- Check the field used to read the Un-Normalised Total from the chromat against the TOTAL high and low limits, unless the limit value equals 0.

If the Check Limits option is not enabled:

- Check the calculated component total against the default high limit (100.5%) and low limit (99.5%).

If the check fails, reject the new composition set and raise the relevant alarm, if enabled:

- If a component or total is less than the low limit, CHROM TELEM MOLE LO.
- If a component or total is greater than the high limit, CHROM TELEM MOLE HI.

---

**Note:**

- For the **GENERIC** chromat type, the flow computer does not calculate the component total, but uses the Un-normalised Total read from the chromat as the calculated total.
  - For the **SIEMENS** chromat type, the flow computer does calculate the component total, but does not check the Un-normalised Total read from the chromat.
- 

### K.4.3 Deviation

When a new analysis becomes available from the chromat, the ordered set (before normalisation, splits or additional are applied) can be verified against deviation limits.

If the Check Deviation option is enabled and a valid analysis has been received from the chromat following a cold start of the flow computer:

- Check all components, plus the calculated component total, against the corresponding deviation limits, unless the limit value equals 0.

If the absolute value of the difference between the new component and the component from the last valid analysis is greater than the deviation limit, the check fails. The following alarm is raised, if enabled:

- CHROM TELEM MOLE DV.

### K.4.4 Normalisation

When a new analysis becomes available from the chromat, the ordered set can be normalised to force the sum of the components to equal 100%. Normalisation can also be applied to the keypad set.

Normalisation is configured using Acceptance Type (configured on the Station Gas Composition and Stream Gas Composition screens in PCSetup). The following options are available:

- ACC/COPY**   ▪ No normalisation is carried out.
- ACC/NORM & AUTO/NORM**   ▪ Normalisation is carried out.

Normalisation is carried out by calculating a Normalisation Factor (NF):



$$NF = 100 / \sum C_A$$

where  $\sum C_A$  is the sum of the un-normalised components mol %.

Each normalised component ( $C_B$ ) is then calculated using:

$$C_B = NF * C_A$$

## K.4.5 Additional

When a new analysis becomes available from the chromat, it is possible to apply additional components to the set. These are components that are not available from the chromat analysis but are available from a laboratory analysis.

In PCSetup, these are entered under Mole Additional, with H<sub>2</sub>S, H<sub>2</sub>O, Helium, Oxygen, CO (Carbon Monoxide) and Hydrogen available for entry.

It is assumed that the entered additional components are already normalised, but the existing components must be adjusted to ensure that the sum of all components is equal to 100%. An additional Normalisation Factor ( $NF_{add}$ ) is calculated:

$$NF_{add} = (100 - \sum C_{add}) / 100$$

where  $\sum C_{add}$  is the sum of the additional components.

Each non-additional component ( $C_C$ ) is then calculated using:

$$C_C = NF_{add} * C_{A/B}$$

Where  $C_{A/B}$  is the normalised component set, or the un-normalised set if normalisation has not been applied.

If an additional component is outside of the low or high limit, an additional component is also present in the composition set from the chromat, or an additional component is also defined in the Mole Splits set, the MOLE SELECT ADDNLS alarm will be raised. When a new analysis becomes available from the chromat, the CHROM TELEM CONFIG alarm will be raised and the analysis will be rejected.

## K.4.6 Splits

If the chromat analysis provides a component that describes the combined mol % of heavier alkanes (C<sub>6+</sub>, C<sub>7+</sub>, C<sub>8+</sub> or C<sub>9+</sub>), it is possible to split this component into individual components (hexane, heptane, octane, nonane and decane). Before splits are applied, C<sub>6+</sub> codes (108-111) are assigned to the C6\_PLUS field, C<sub>7+</sub>/C<sub>8+</sub>/C<sub>9+</sub> codes (150-152) are assigned to the CX\_PLUS field.

Splits are configured in PCSetup using the Apply Splits selection and the Mole Splits set. The options for Apply Splits are described below.

**NO SPLITS** For GENERIC and SIEMENS chromat types:

If a component is assigned to C6\_PLUS in the Mole Order array it is copied to hexane and C6\_PLUS is zeroed in the adjusted component set.

If a component is assigned to CX\_PLUS in the Mole Order array it is copied to heptane and CX\_PLUS is zeroed in the adjusted component set.

For EURO and USA chromat types:

The value assigned to the C6\_PLUS component field will be split according to the C6\_PLUS component code:

$$C_D^{HEXANE} = C_C^{C6\_PLUS} * F_{HEX}$$

$$C_D^{HEPTANE} = C_C^{C6\_PLUS} * F_{HEP}$$

$$C_D^{OCTANE} = C_C^{C6\_PLUS} * F_{OCT}$$

C6_PLUS Code	F <sub>HEX</sub>	F <sub>HEP</sub>	F <sub>OCT</sub>
108	0.47466	0.3534	0.17194
109	0.5	0.5	0.0
110	0.5	0.25	0.25
111	0.57143	0.28572	0.14285

The output value of the C6\_PLUS component will be set to 0.0%.

The value assigned to the CX\_PLUS component field will be assigned to a particular component according to the CX\_PLUS component code:

CX_PLUS Code	C <sub>D</sub> <sup>HEPTANE</sup>	C <sub>D</sub> <sup>OCTANE</sup>	C <sub>D</sub> <sup>NONANE</sup>	C <sub>D</sub> <sup>DECANE</sup>
150	0.0%	0.0%	C <sub>C</sub> <sup>CX_PLUS</sup>	0.0%
151	0.0%	C <sub>C</sub> <sup>CX_PLUS</sup>	0.0%	0.0%
152	C <sub>C</sub> <sup>CX_PLUS</sup>	0.0%	0.0%	0.0%

The output value of the CX\_PLUS component will be set to 0.0%.

**C6PLUS** When Apply Splits = C6PLUS, the value assigned to the C6\_PLUS component field will be split using the entered Mole Splits values.

STR01 MOLE SPLITS	
HEXANE	100 %
HEPTANE	0 %
OCTANE	0 %
NONANE	0 %
DECANE	0 %

Figure K-1. Gas Composition – MOLE SPLITS

$$C_D^{HEXANE} = C_C^{C6\_PLUS} * SPLIT\%^{HEXANE} * 0.01$$

$$C_D^{HEPTANE} = C_C^{C6\_PLUS} * SPLIT\%^{HEPTANE} * 0.01$$

$$C_D^{OCTANE} = C_C^{C6\_PLUS} * SPLIT\%^{OCTANE} * 0.01$$

$$C_D^{NONANE} = C_C^{C6\_PLUS} * SPLIT\%^{NONANE} * 0.01$$

$$C_D^{DECANE} = C_C^{C6\_PLUS} * SPLIT\%^{DECANE} * 0.01$$

The output value of the C6\_PLUS component will be set to 0.0%.

**C7PLUS** When Apply Splits = C7PLUS, the value assigned to the CX\_PLUS component field will be split using the entered Mole Splits values.

$$C_D^{HEPTANE} = C_C^{CX\_PLUS} * SPLIT\%^{HEPTANE} * 0.01$$

$$C_D^{OCTANE} = C_C^{CX\_PLUS} * SPLIT\%^{OCTANE} * 0.01$$

$$C_D^{NONANE} = C_C^{CX\_PLUS} * SPLIT\%^{NONANE} * 0.01$$

$$C_D^{DECANE} = C_C^{CX\_PLUS} * SPLIT\%^{DECANE} * 0.01$$

The output value of the CX\_PLUS component will be set to 0.0%.

**C8PLUS** When Apply Splits = C8PLUS, the value assigned to the CX\_PLUS component field will be split using the entered Mole Splits values.

$$C_D^{OCTANE} = C_C^{CX\_PLUS} * SPLIT\%^{OCTANE} * 0.01$$

$$C_D^{NONANE} = C_C^{CX\_PLUS} * SPLIT\%^{NONANE} * 0.01$$

$$C_D^{DECANE} = C_C^{CX\_PLUS} * SPLIT\%^{DECANE} * 0.01$$

The output value of the CX\_PLUS component will be set to 0.0%.

**C9PLUS** When Apply Splits = C9PLUS, the value assigned to the CX\_PLUS component field will be split using the entered Mole Splits values.

$$C_D^{NONANE} = C_C^{CX\_PLUS} * SPLIT\%^{NONANE} * 0.01$$

$$C_D^{DECANE} = C_C^{CX\_PLUS} * SPLIT\%^{DECANE} * 0.01$$

The output value of the CX\_PLUS component will be set to 0.0%.

**C10PLUS** Not used (treated as NO SPLITS).

If Apply Splits = C6PLUS but heavier alkanes are assigned to the CX\_PLUS field, no split processing will take place. The same applies if Apply Splits = C7/8/9PLUS but heavier alkanes are assigned to the C6\_PLUS field.

If the sum of the Mole Splits does not equal 100%, the MOLE SELECT SPLITS alarm will be raised. When a new analysis becomes available from the chromat, the CHROM TELEM CONFIG alarm will be raised and the analysis will be rejected.

### K.4.7 Critical Alarms

When a new analysis becomes available from the chromat, it is possible to check if Critical alarms are being indicated by the chromat. This is configured in PCSetup using the Check Critical Alarms selection.

When the check is enabled, for the chromat types EURO, USA and GENERIC, two fields read from the chromat via Modbus are evaluated for the statuses of specified bits, as shown in the following table (fields belong to CHR REGISTERS array):

TYPE	Bit	15	14	13	12	11	10	9	8	7	6	5	4	3	2	1	0
EURO	Field 06		x	x	x				x	x			x	x	x	x	x
	Field 07												x	x		x	
USA	Field 14	x	x														
	Field 15														x		x
GENERIC	Field 06		x														
	Field 07														x		

For the EURO and USA default Modbus maps, the two fields are used to read addresses 3046 and 3047.

For chromat type SIEMENS, the value of Field 01 of the CHR REGISTERS array, read from the chromat via Modbus is used to check for Critical alarm status. If the value of this field is < 600, this is taken to indicate critical alarms.

For all chromat types, if Critical alarms are indicated then the new analysis will be rejected. The following alarm is raised, if enabled:

- CHROM TELEM CRITICAL.

### K.4.8 Non-Critical Alarms

When a new analysis becomes available from the chromat, it is possible to check if Non-Critical alarms are being indicated by the chromat. This is configured in PCSetup using the Check Non Critical Alarms selection.

When the check is enabled, for the chromat types EURO, USA and GENERIC, two fields read from the chromat via Modbus are evaluated for the statuses of specified bits, as shown in the following table (fields belong to CHR REGISTERS array):

TYPE	Bit	15	14	13	12	11	10	9	8	7	6	5	4	3	2	1	0
EURO	Field 06	x				x	x	x									
	Field 07														x		x
USA	Field 14											x	x	x	x		
	Field 15													x			
GENERIC	Field 06											x	x	x	x		
	Field 07																

For the EURO and USA default Modbus maps, the two fields are used to read addresses 3046 and 3047.

For chromat type SIEMENS, there is no check for Non-Critical alarms.

If Non-Critical alarms are indicated then the new analysis will be rejected. The following alarm is raised, if enabled:

- CHROM TELEM NCRITICAL.

## K.4.9 Timeouts

The following timeout values are available (dependent on the configuration selections made):

**Analysis Timeout** – this is enterable via PCSetup and is also changeable for a running configuration (if configured on a display). It specifies the maximum time (in seconds) that the S600+ will wait to receive a new composition from the GC before raising an alarm. If it is set to 0, then no timeout checks are performed.

**Download Timeout** – this is enterable via PCSetup and is also changeable for a running configuration (if configured on a display). It specifies the maximum time (in minutes) that the S600+ will wait to receive a new composition from the supervisory computer before raising an alarm. If it is set to 0, then no timeout checks are performed. (See *Section K.11.5, Download Flag* for details of how to configure the Download Flag to prevent the Download Timeout alarm when the Download composition set does not change).

## K.5 Auxiliary Data

Additional data items may also be available from a GC (other than mol% data). These are requested once the composition data has been received using the POLL CV telemetry message trigger. (For the SIEMENS type, the POLL CV trigger is not set, so the request for Auxiliary Data should use the POLL MOLES trigger).

### K.5.1 EURO (2551 / 2350 EURO) + USA (2251 / 2350 USA)

The auxiliary data is located at the following Modbus addresses:

- 7033** – Dry Superior CV – This is read into CHR RAW MISC (FIELD 01) and by default this is copied to the REAL CV Object CALC2 field
- 7034** – Saturated Superior CV – This is read into CHR RAW MISC (FIELD 02) and is used for information purposes only
- 7035** – Real Relative Density – This is read into CHR RAW MISC (FIELD 03) and by default this is copied to the REAL RD object CALC4 field
- 7036** – Compressibility (Z) – This is read into CHR RAW MISC (FIELD 04) and is used for information purposes only
- 7037** – Superior Wobbe Index – This is read into CHR RAW MISC (FIELD 05) and is used for information purposes only
- 7038** – Un-Normalised Total - This is read into CHR RAW MISC (FIELD 06) and is used in the composition checks detailed in section K4.2
- 7039** – Molar Mass – This is read into CHR RAW MISC (FIELD 07) and is used for information purposes only
- 7087** – Dry Inferior CV – This is read into CHR RAW MISC (FIELD 21) and by default this is copied to the REAL CV object CALC4 field

### K.5.2 SIEMENS + GENERIC

The Modbus addresses that hold this data will be dependent on the GC model. The handling of Dry CV and Real Relative Density will be as above providing the Modbus map is configured to use the correct fields within the CHR RAW MISC database object. For GENERIC type, the Un-Normalised Total is used in the composition checks detailed in *Section K.4.2, High/Low Limits*.

### K.5.3 Station to Stream Copying

For streams that take their chromat data from a Station, the Auxiliary data is updated according to the option chosen in Config Generator.

- Moles from Station Only** In-use Station Real Relative Density is copied to CALC4 field of the Stream Real Relative Density (CHROMAT mode value).
- Station Superior Chromat Real CV (SUP CHROMAT mode value) is copied to the CALC2 field of the Stream Real CV (SUP CHROMAT mode value).
- Station Inferior Chromat Real CV (INF CHROMAT mode value) is copied to the CALC4 field of the Stream Real CV (INF CHROMAT mode value).

**Moles from Station Chromat** For matching data sets (when the GC Stream read via Modbus matches the configured GC Stream), the Stream CHR RAW MISC array is updated with values from the Station CHR RAW MISC array. Stream Real Relative Density and Real CV are then updated as described in *Section K.5.1, EURO (2551/2350 EURO) + USA (2251/2350 USA)*.

## K.6 Dual GC Handling

The S600+ also has the option to have Dual GCs at station level. This is selected in Config Generator when configuring the station – the options are Single Chromat, Dual Chromat, No Chromat. Refer to *Section 5.5, Station Gas Composition* for details on the selectable options available.

When Dual GC handling is selected, the S600+ always polls both configured GC's and processes the composition data based on the Type (configured on the Station Gas Composition and Stream Gas Composition screens) that is selected.

These selections are detailed below:

### K.6.1 CHROMAT A

If Chromat A is selected, the S600+ always uses the composition data from GC A as a priority.

If the link to GC A fails or the composition received is deemed invalid, then the composition from GC B is be used provided it is valid (refer to *Section K.4, Composition Processing* for details on the checks performed).

If the composition data from both GC A and B is invalid (or both links have failed), then the Last Good data (or Keypad Data) is used (depending on the configuration selections made).

If GC B data becomes valid, this will be used until GC A data is good, then GC A data will be used as a priority.

### K.6.2 CHROMAT B

If Chromat B is selected, the S600+ always uses the composition data from GC B as a priority.

If the link to GC B fails or the composition received is deemed invalid, then the composition from GC A is used provided it is valid (refer to *Section K.4, Composition Processing* for details on the checks performed).

If the composition data from both GC A and B is invalid (or both links have failed), then the Last Good data (or Keypad Data) is used (depending on the configuration selections made).

If GC A data becomes valid, this will be used until GC B data is good, then GC B data will be used as a priority.

### K.6.3 CHROMAT AUTO

If Chromat AUTO is selected, the S600+ alternates between using GC A and GC B data. The philosophy behind this is that the analysis cycles at the two GC's will be offset from each other. For example, if each GC performs an analysis every 20 minutes and these analysis have a 10-minute offset from each other the S600+ would receive a new analysis every 10 minutes.

GC A Analysis at 00:00. 00:20, 00:40, etc.

GC B Analysis at 00:10. 00:30, 00:50, etc.

S600+ new analysis at 00:00 (GC A), 00:10 (GC B), 00:20 (GC A), etc.

If the link to GC A fails or the composition received is deemed invalid, then the composition from GC B will be used provided it is valid (refer to *Section K.4, Composition Processing* for details on the checks performed).

If the link to GC B fails or the composition received is deemed invalid, then the composition from GC A will be used provided it is valid (refer to *Section K.4, Composition Processing* for details on the checks performed).

If the composition data from both GC A and B is invalid (or both links have failed), then the Last Good data (or Keypad Data) is used (depending on the configuration selections made).

If GC A data becomes valid, this will be used until GC B data is good, then the switching between GC A and GC B will restart.

Similarly, if GC B data becomes valid, this will be used until GC A data is good, then the switching between GC A and GC B will restart.

---

## K.7 Displays

### K.7.1 Default Displays

The displays for the GCs can be located under one of two places on the web server or front panel depending on how the application was configured.

For applications that assign a GC to a station, then the composition information can be found under:

**Operator > Station n > Composition**

where **n** is the station number

For applications that assign a GC to a stream, then the composition information can be found under:

**Operator > Stream n > Composition**

where **n** is the stream number

The following table shows the items that are available in the default Composition displays:



---

**Note:** It is recommended that if splits / mol lo / mol hi / mol dev / user or download options are selected that these displays are added by the user. This can be done by using the Display Editor. For more information refer to *Chapter 13, Display Editor*.

---

Item	Definition
<b>Mole Select</b>	Selects which composition set is used. Details in <i>Section K.2, Gas Composition Modes</i> .
<b>Acceptance Command</b>	Used to accept a new Keypad moles composition set. Details in <i>Section K.2, Gas Composition Modes</i> .
<b>Keypad Moles</b>	Displays the values for the Keypad moles composition set. These values can be modified by the user.
<b>Selected Moles</b>	Displays the values for the Selected moles composition set (in-use).
<b>Telem Stage</b>	Indicates the current stage for the chromat task. Details in <i>Section K.3, Chromat Telemetry</i> .
<b>Telem Poll Delay</b>	Specifies the time in seconds to wait between issuing polls to the chromat. Details in <i>Section K.3, Chromat Telemetry</i> .
<b>Telem Reset Delay 1</b>	Delay before issuing a reset of the new data flag after a new analysis has been received and processed for a matching cycle stream. Details in <i>Section K.3, Chromat Telemetry</i> .
<b>Telem Reset Delay 2</b>	Delay before issuing a reset of the new data flag after a new analysis has been received and processed but the cycle streams do not match, for example on an analysis for stream 1 was expected but the chromat indicated the analysis was for stream 2. Details in <i>Section K.3, Chromat Telemetry</i> .
<b>D/Load Timeout</b>	Defines a timeout which, when expired, raises an alarm to indicate that the supervisory (Modbus master) has not written a new Download composition set in time. Details in <i>Section K.4.9, Timeouts</i> .

---

## K.8 Alarms

---

### K.8.1 Default Alarms

The following chromatograph alarms are available:

Alarm	Definition
<b>CHROM TELEM CONFIG</b>	Occurs when a new analysis is available from the GC, but a fault associated with the MOLE SELECT SPLITS or ADDNLS alarms is present.
<b>CHROM TELEM CRITICAL</b>	Occurs when the GC is indicating a Critical alarm. See <i>Section K.4.7, Critical Alarms</i> .
<b>CHROM TELEM MOLE DV</b>	Occurs when a component, or the total, of the new composition set from the GC is deviates from the previously received value by more than the limit. See <i>Section K.4.3, Deviation</i> .
<b>CHROM TELEM MOLE HI</b>	Occurs when a component, or the total, of the new composition set from the GC is higher than the high limit. See <i>Section K.4.2, High/Low Limits</i> .

<b>CHROM TELEM MOLE LO</b>	Occurs when a component, or the total, of the new composition set from the GC is lower than the low limit. See <i>Section K.4.2, High/Low Limits</i> .
<b>CHROM TELEM NCRITICAL</b>	Occurs when the GC is indicating a Non Critical alarm. See <i>Section K.4.8, Non-Critical Alarms</i> .
<b>CHROM TELEM REP TOUT</b>	Occurs when the GC has not indicated that a new composition set is available within the timeout period specified. See <i>Section K.4.9, Timeouts</i> .
<b>CHROM TELEM RX FAIL</b>	Occurs when the timeout period for the GC to respond has expired. See <i>Section K.3, Chromat Telemetry</i> .
<b>DL COMP</b>	Occurs when that the downloaded set has been rejected. This can be because one of the components is outside the limits for that component or because the sum of the downloaded components is less than 98% or greater than 102%. <b>Note:</b> No normalisation of a download set occurs - the downloaded composition is expected to already be normalised to 100%.
<b>DL T/OUT</b>	Occurs when the S600+ has not received an updated composition from the supervisory system within the configured Download Timeout period.
<b>K_COMP</b>	Occurs when the keypad entered composition is outside the limits set on the Gas Composition page on PCSetup. This check applies to the total and the individual components.
<b>MOLE DV</b>	Occurs when any component (MOLE DeViation) exceeds the deviation limit percentage set up in PCSetup on the Gas Composition page. This alarm is raised for the complete composition; diagnose the component that is in error.
<b>MOLE HI</b>	Occurs when any component exceeds the highest acceptable percentage set up in PCSetup on the Gas Composition page. This alarm is raised for the complete composition; diagnose the component that is in error.
<b>MOLE LO</b>	Occurs when any component falls below the lowest acceptable percentage set up in PCSetup on the Gas Composition page. This alarm is raised for the complete composition; diagnose the component that is in error.
<b>MOLE SELECT ADDNLS</b>	Occurs when an additional component is outside of the low or high limit, an additional component is also present in the composition set from the GC, or an additional component is also defined in the Mole Splits set. See <i>Section K.4.5, Additional</i> .
<b>MOLE SELECT DL COMP</b>	Occurs when a component, or the total, of the Download composition set is outside of the low or high limit. See <i>Section K.4.2, High/Low Limits</i> .
<b>MOLE SELECT DL T/OUT</b>	Occurs when the Download composition set has not changed within the timeout period specified. See <i>Section K.4.9, Timeouts</i> .
<b>MOLE SELECT K_COMP</b>	Occurs when a component, or the total, of the keypad entered composition set is outside of the low or high limit. See <i>Section K.4.2, High/Low Limits</i> .
<b>MOLE SELECT SPLITS</b>	Occurs when the entered Mole splits do not add up to 100%. See <i>Section K.4.6, Splits</i> .

<b>MOLE SELECT USER COMP</b>	Occurs when a component, or the total, of the User composition set is outside of the low or high limit. See <i>Section K.4.2, High/Low Limits</i> .
----------------------------------	---

## K.9 Reports

### K.9.1 CHR TELEMETRY

By default, when you select a GC, the system **does not** automatically add the GC telemetry report. You must **add** it manually.

Once added the report will automatically generate every time a new analysis is received (and validated) from the GC.

To configure the report:

1. Select **System Setup > Reports**. The Reports screen opens.

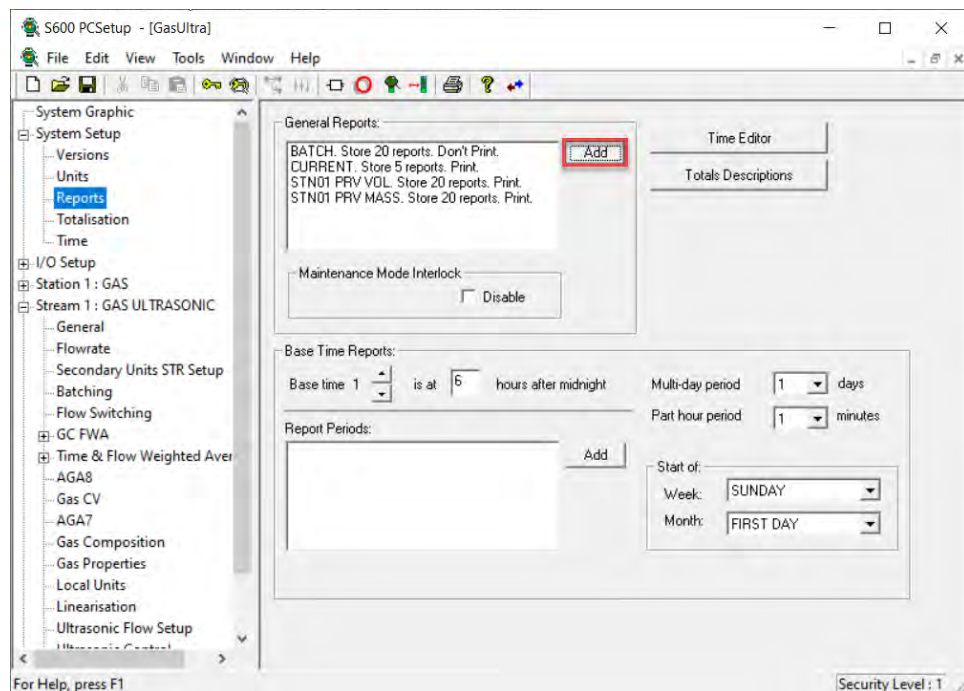

*Figure K-2. Add Report – CHR TELEMETRY*

2. Click **Add** in the General Report section to add the report. The Archive Configuration screen opens.

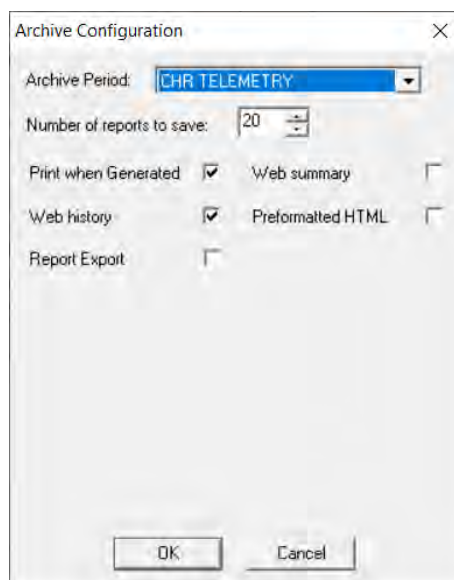

*Figure K-3. CHR TELEMETRY*

3. Select **CHR TELEMETRY** in the Archive Period field.
4. Enter the number of reports you wish to save.
5. Click **OK** when you have finished.

When generated, the report should resemble the following example:

Config600 Report Editor - [rep23.txt]

File Edit View Window Help

0 CHROMAT REPORT dd/mm/yyyy hh:mm:ss

=====

STREAM 1 NAME: GAS DP  
LOCATION: LINE 01

LAST ANALYSIS AT : 12.00 23/08/04  
CURR REPORT STAT : 0

REAL CV :  
REAL RD (SG) :  
MOLE SELECT : KEYPAD  
PREV SELECTED SET :

	RAW MOLE PCNTS	KEYPAD MOLES	SELECTED MOLES
REAL CV	0.000000	37.000000	37.000000
REAL RD (SG)	0.000000	0.600000	0.600000
NITROGEN	0.000000	0.259500	0.259500
CO2	0.000000	0.595600	0.595600
H2S	0.000000	0.000000	0.000000
H2O	0.000000	0.000000	0.000000
HELIUM	0.000000	0.000000	0.000000
METHANE	0.000000	96.522200	96.522200
ETHANE	0.000000	1.818600	1.818600
PROPANE	0.000000	0.459600	0.459600
N_BUTANE	0.000000	0.100700	0.100700
I_BUTANE	0.000000	0.000000	0.000000
N_PENTANE	0.000000	0.243800	0.243800
I_PENTANE	0.000000	0.000000	0.000000
NEO_PENTANE	0.000000	0.000000	0.000000
HEXANE	0.000000	0.000000	0.000000
HEPTANE	0.000000	0.000000	0.000000
OCTANE	0.000000	0.000000	0.000000
NONANE	0.000000	0.000000	0.000000
DECANE	0.000000	0.000000	0.000000
OXYGEN	0.000000	0.000000	0.000000
CO	0.000000	0.000000	0.000000
HYDROGEN	0.000000	0.000000	0.000000
BENZENE	0.000000	0.000000	0.000000
TOLUENE	0.000000	0.000000	0.000000
ARGON	0.000000	0.000000	0.000000
C6_PLUS	0.000000	0.000000	0.000000
CX_PLUS	0.000000	0.000000	0.000000
TOTAL	0.000000	0.000000	100.000000

=====

For Help, press F1

Figure K-4. Example Report – CHR TELEMETRY

Using the Report Editor, you can modify the layout of the report. For more information, refer to *Chapter 12, Report Editor*.

## K.9.2 CHR D/LOAD

By default, when you select downloaded moles, the system **does not** automatically add the download report. You must **add** it manually.

Once added it will automatically generate every time a new composition is downloaded from the supervisory.

To configure the report:

1. Select **System Setup > Reports**. The Reports screen opens.

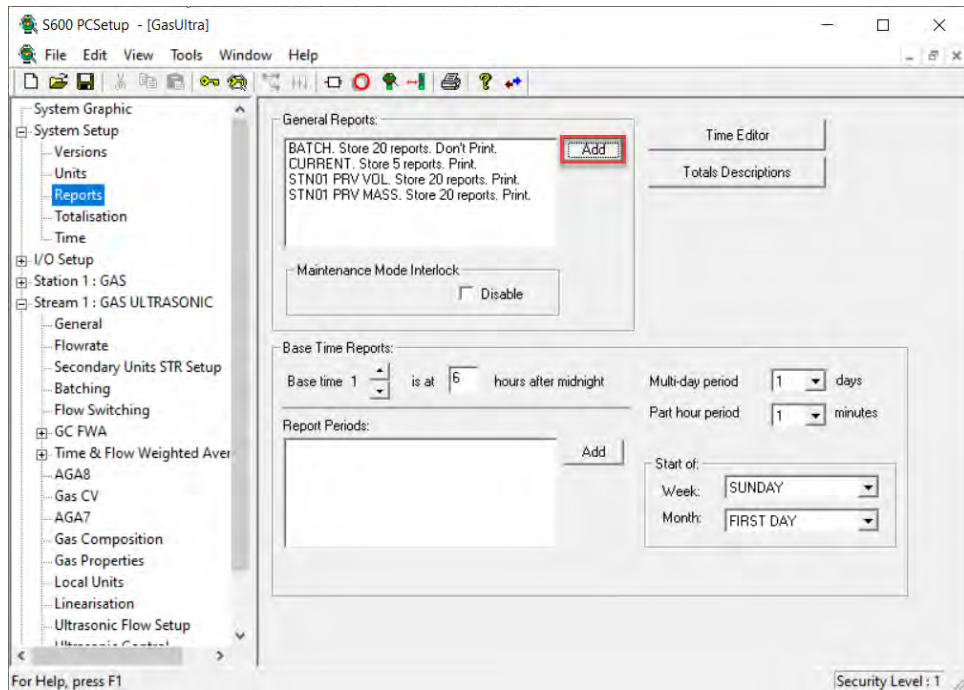

Figure K-5. Add Report – CHR D/LOAD

2. Click **Add** in the General Reports section to add the report. The Archive Configuration screen opens.

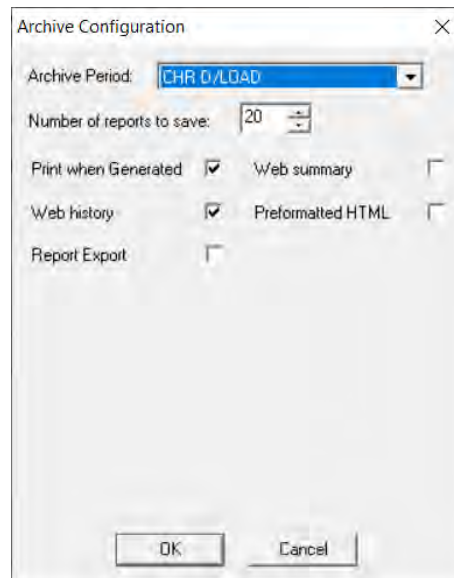

Figure K-6. CHR D/LOAD

3. Select **CHR D/LOAD** from the list.
4. Select the number of reports you wish to save.
5. Click **OK** when you have finished.

When generated, the report should resemble the following example:

Config600 Report Editor - [rep22.txt]

File Edit View Window Help

0 CHROMAT REPORT dd/mm/yyyy hh:mm:ss

---

STATION 1

D/L TIME STAMP : 12.00 28/08/08

D/LOAD STATUS : NULL

MOLE SELECT : KEYPAD

PREV SELECTED SET :

	DOWNLOADED MOLES	KEYPAD MOLES	SELECTED MOLES
NITROGEN	0.000000	0.259500	0.259500
CO2	0.000000	0.595600	0.595600
H2S	0.000000	0.000000	0.000000
H2O	0.000000	0.000000	0.000000
HELIUM	0.000000	0.000000	0.000000
METHANE	100.000000	96.522200	96.522200
ETHANE	0.000000	1.818600	1.818600
PROPANE	0.000000	0.459600	0.459600
N_BUTANE	0.000000	0.100700	0.100700
I_BUTANE	0.000000	0.000000	0.000000
N_PENTANE	0.000000	0.243800	0.243800
I_PENTANE	0.000000	0.000000	0.000000
NEO_PENTANE	0.000000	0.000000	0.000000
HEXANE	0.000000	0.000000	0.000000
HEPTANE	0.000000	0.000000	0.000000
OCTANE	0.000000	0.000000	0.000000
NONANE	0.000000	0.000000	0.000000
DECANE	0.000000	0.000000	0.000000
OXYGEN	0.000000	0.000000	0.000000
CO	0.000000	0.000000	0.000000
HYDROGEN	0.000000	0.000000	0.000000
BENZENE	0.000000	0.000000	0.000000
TOLUENE	0.000000	0.000000	0.000000
ARGON	0.000000	0.000000	0.000000
C6_PLUS	0.000000	0.000000	0.000000
CX_PLUS	0.000000	0.000000	0.000000
TOTAL	0.000000	0.000000	100.000000

Figure K-7. Example Report – CHR D/LOAD

Using the Report Editor, you can modify the layout of the report. For more information, refer to *Chapter 12, Report Editor*.

## K.10 Modbus Maps

This section contains examples of the Modbus Maps that PCSetup will generate.

### EURO / USA Types

The auto generated map for these options is identical and contains all Modbus addresses for each GC. The structure of the Modbus map takes its definition from the standard Emerson GC Modbus maps (SIM\_2251 and SIM\_2251 UK). The GC Type selection determines which of these addresses is polled for and this is handled internally within the S600+, using triggers for individual Modbus messages.

Each type polls a different range of addresses for the CHR REGISTERS data.

Type	Addresses	Message Trigger
EURO	3041-3061	CHR REQ.STAT 1
USA	3033-3059	CHR REQ.STAT 2

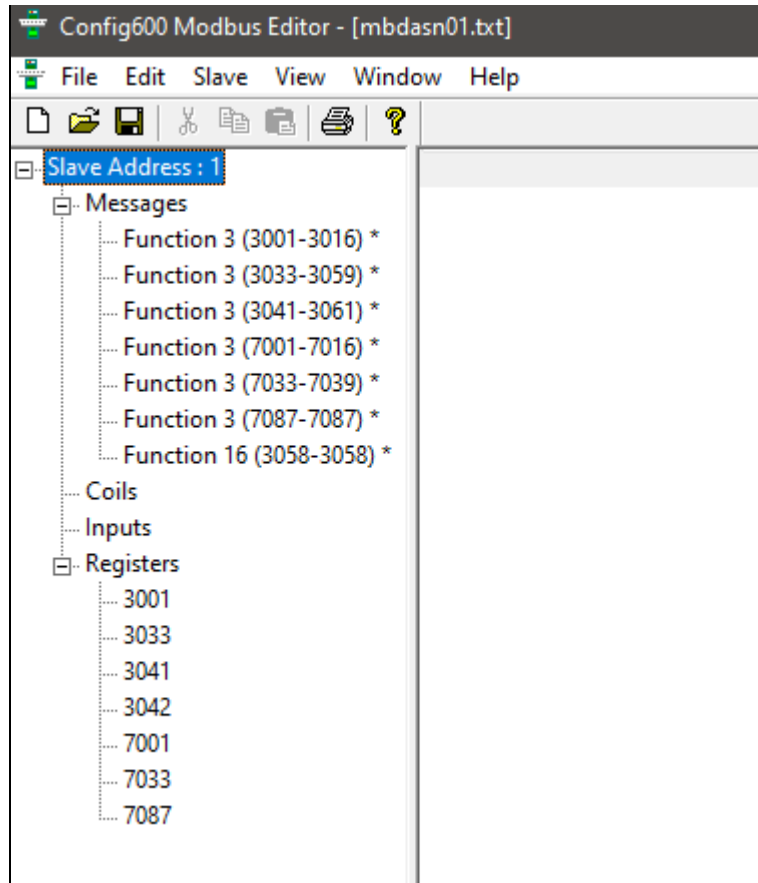

Figure K-8. CHR TELEMETRY

**GENERIC / SIEMENS Types**

The above map is provided by default for these GC Type options – it must therefore be modified in line with the specific GC requirements.

For more information, refer to *Chapter 14, Modbus Editor*.

For the required data points and message triggers, refer to How To document 197 for SIEMENS and 158 for GENERIC.

**K.11 User Customisation – How Tos**

The following sections describe custom changes to the flow computer chromat handling that can be carried out by the user using Config600. Some changes may involve the use of System Editor, which requires a Pro Licence.



### **K.11.1 SIEMENS GC**

Refer to **How To 197** (available from Emerson Support) for details on how to configure the SIEMENS GC Type.

### **K.11.2 GENERIC GC**

Refer to **How To 158** (available from Emerson Support) for details on how to configure the GENERIC GC Type.

### **K.11.3 Multi-dropped GCs**

Refer to **How To 141** (available from Emerson Support) for details on how to configure Multi-dropped GCs on a single RS-485 link.

### **K.11.4 Mole Select – Keypad Fail Switchback**

Refer to **How To 231** (available from Emerson Support) for details on how to configure Mole Select to automatically revert to Chromat mode from Keypad Fail mode once a valid analysis becomes available. (Requires Pro Licence.)

### **K.11.5 Download Flag**

Refer to **How To 230** (available from Emerson Support) for details on how to configure the Download Flag to prevent a Download Timeout alarm when the Download composition set has not changed. (Requires Pro Licence.)

*[This page is intentionally left blank.]*

## Appendix L – Backup Functionality

### In This Chapter

L.1	Backup Command.....	L-1
L.2	Configuration Upload.....	L-1
L.3	PCSetup / System Editor.....	L-1

The backup functionality allows you to save user-configurable items to a file stored in flash memory.

### L.1 Backup Command

On a running S600+, you can execute the backup command to store any changes made to user-configurable items.

The backup command is located under Menu 5 (System Settings) / Page 6 (Software Status). When the system Run Mode is changed, you have the option of Cold Start, Warm Start, or Backup.

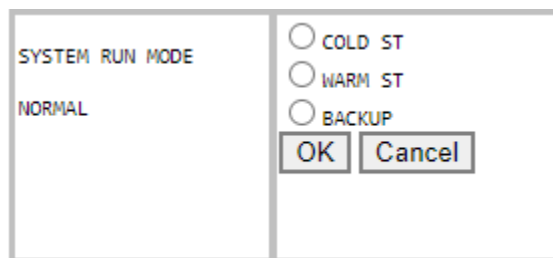

If you select Backup, all the current settings are written to the exback file (which is held in flash memory).

**Note:** If the running S600+ already contains an exback file, the file is deleted and re-created to ensure all data is stored (for example, from new displays).

If the S600+ is subsequently cold started, the changes contained in the exback file are used to update the running machine.

### L.2 Configuration Upload

The configuration from a running S600+ can be uploaded to a PC using the Transfer tools (Receive Tab). Refer to *Chapter 9 – Config Transfer* for more information.

### L.3 PCSetup / System Editor

If an exback file exists and PCSetup or System Editor is used to open the configuration, the you are presented with a prompt to Synchronise the data.

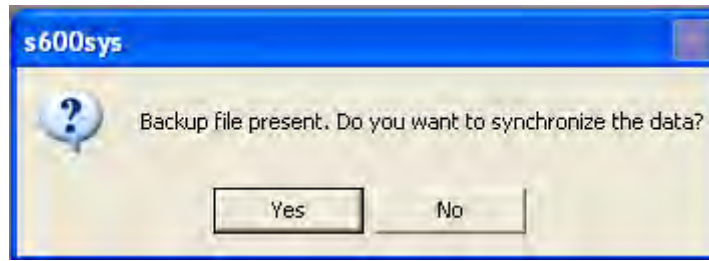

Select **Yes** to copy data from the exback file into the existing configuration and then delete the exback file.

---

**Note:** If you need to recover the original configuration, a copy of the deleted exback file is placed in the logs folder and renamed backup.log. Additionally, the entire configuration folder is copied before the synchronisation occurs and renamed as <configuration>\_bkup.

---

Select **No** to leave the exback file in the extras folder and to not synchronise the data. You will be prompted to synchronise the data again the next time you open the configuration unless you manually delete the exback file.

## L.4 Configuration Download

---

The configuration can be downloaded to the S600+ using the Transfer tools (Send Tab). Refer to *Chapter 9 – Config Transfer* for more information.

---

**Note:** If the exback file is still present in the extras folder when the configuration is downloaded (i.e., no synchronisation has occurred), the changes within the exback file will overwrite any changes made within PCSetup.

---

# Index

## 1

- 1.59e-005..... 6-66
- 15/15 Deg C..... 6-69, 6-115, 6-139
- 1962..... 6-77

## 3

- 3 Identical Cell..... 6-106

## A

- A CRUDE.....
  - ..... 5-23, 5-36, 5-50, 6-173, 6-199, 6-207, 6-222
- About
  - About Config600..... 2-27
  - About PCSetup..... 2-27
  - About System Editor..... 8-6
- abs(x)
  - LogiCalc Editor..... 15-27
- ABT 1 Alarm..... 7-6
- ACC/Copy..... 5-10, 6-31, 6-82, 6-122, 6-145
- ACC/Norm..... 5-10, 6-31, 6-82, 6-122, 6-145
- Acceptance Type... 5-10, 6-31, 6-82, 6-122, 6-145
- Access Allowed..... 7-21
- Access, security..... 7-14
- Accessing
  - Display Editor..... 13-1
  - LogiCalc Editor..... 15-2, 15-5
  - Remote Archive Uploader..... 11-2
  - Remote Front Panel..... 10-7
  - System Editor..... 8-2
- Accessing Config600..... 1-8
- Accessing Modbus Editor..... 14-2
- Activating
  - Activation Code..... 1-9
  - Config600..... 1-9
- Active Alarms/Events..... 7-4
- ADC..... A-1, E-2
  - Analogue Input Object..... D-4, D-7
  - Linear Two-point ADC Device Calibration..... D-3
  - Modes (MODE TAB PLANTI/O)..... E-21
- Add All Inputs..... 7-26
- Add All Outputs..... 7-27
- Adding
  - Adding an Item..... 7-24
  - Base Time Report to a Configuration..... 3-11
  - Discrete (Digital) Inputs..... 4-4
  - New I/O Point..... 4-15
  - Reports..... 3-13
- Adding a Data Point..... 12-7
- Adding a General Report..... 3-10
- Adding a Modbus Data Point..... 14-5
- Adding Report Lines..... 12-9
- Addnls Alarm..... 7-6
- Address . 2-16, 5-10, 6-31, 6-82, 6-122, 6-145, A-1
  - Address Map..... 4-30
  - Slave Comm Port..... 4-30

- Address Map..... 4-33
- Adiabatic exponent..... 6-126
- Advanced Setup Configuration..... 7-1
- A-Fail Alarm..... 7-6
- AGA..... A-1
- AGA3..... 6-80
- AGA3 (Volume Flowrate)..... 6-80
- AGA5..... 6-25, 6-30
- AGA7..... 6-119, 6-143
- AGA7 (Gross Volume Flowrate)..... 6-119, 6-143
- AGA8..... 6-23, 6-56, 6-112, 6-136
  - AGA8 (Compressibility) - Gas DP..... 6-56
  - AGA8 (Compressibility) - Gas Turbine..... 6-112
  - AGA8 (Compressibility) - Gas Ultrasonic..... 6-136
- AI..... A-1
- Air..... 6-68
  - Relative Humidity..... 6-68
- AirCO2 Content..... 6-68
- Alarm
  - PR OP Fxd..... 7-11
- ALARM..... E-3
- Alarm Acceptance on TX..... 4-34
- Alarm and Event
  - Descriptions..... 7-6
- Alarm Limits..... 6-5, 6-110, 7-15
  - Ball Prover..... 5-31
  - Compact Prover..... 5-44
  - Master Meter Prover..... 5-56
  - Qsonic..... 6-163
  - Station..... 5-2
- ALARMHIST..... E-3
- Alarms..... 5-10, 6-5, 6-26, 6-30, 6-31, 6-45, 6-82, 6-122, 6-145, 7-3
  - ABT 1..... 7-6
  - Addnls..... 7-6
  - A-Fail..... 7-6
  - AGA3..... 6-80
  - AGA7..... 6-119, 6-143
  - AGA8..... 6-23, 6-56, 6-112, 6-136
  - Alarm Accept on TX..... 4-30
  - Alarm Accepts..... 7-21
  - Alarm Archive Size..... 7-4
  - Alarm Disable & Suppress..... 7-15
  - Alarm Mode Latched..... 7-4
  - Alarm System Operation..... 7-4
  - Alarm Text Tables..... E-19
  - Annubar..... 6-66
  - Bad Pulse..... 7-6
  - Ball Prover Alarm Limits..... 5-31
  - Batching..... C-30
  - Batt Fail..... 7-6
  - B-Fail..... 7-6
  - Blocked..... 7-6
  - Calc Fail..... 7-7
  - Can Full..... 7-7
  - Can Hgh..... 7-7
  - Cell Input..... 6-95

Check Critical Alarms.....	5-10, 6-31, 6-82, 6-122, 6-145	Lo .....	7-9
Cold Start .....	7-7	LogiCalc Editor .....	15-2
Common.....	7-7	LoLo.....	7-9
Compact Prover Alarm Limits.....	5-44	Low Flow .....	7-9
Complete.....	7-7	Low Prd .....	7-9
Conf CSum.....	7-7	MA IP Err.....	7-9
Conf Err.....	7-7	MA Op Fxd.....	7-9
Config .....	7-7	MA Op Sat .....	7-9
Config Chg.....	7-7	Master Meter Prover Alarm Limits .....	5-56
Coriolis.....	6-36, 6-189	Mole Dv .....	7-10
CRC Fail.....	7-7	Mole Fail.....	7-10
Critical.....	7-7	Mole Hi.....	7-10
Data Tout.....	7-8	Mole Lo.....	7-10
Denied .....	7-8	Monitor.....	7-10
Dens Limit.....	7-8	Move Uncm.....	7-10
Dev Err.....	7-8	No Permit.....	7-10
Dev Open .....	7-8	NX19.....	6-77
Discrep.....	7-8	O/P Err.....	7-10
Drv Gain.....	7-8	O-Flow.....	7-10
Dscrp .....	7-8	O-Range.....	7-10
Editing.....	7-4	Overflow .....	7-10
EEProm Fail.....	7-8	Pic Fail .....	7-11
Error .....	7-8	Pipe Correction.....	6-53
Event 1.....	7-8	PR OP Sat .....	7-11
Event 2.....	7-8	Pre Warn.....	7-11
Exception.....	7-8	Printer Communications .....	7-4
Fail A .....	7-8	Printing Err.....	7-11
Fail B .....	7-8	PTZ.....	6-78
Fail CH_A.....	7-8	Pure Gas/Air.....	6-68
Fail CH_B.....	7-9	Pwr Reset.....	7-11
Fail CH_C.....	7-9	QSonc .....	6-164
Fail CH_D.....	7-9	RAM Fail.....	7-11
Fail IO.....	7-9	ROC.....	7-11
Fail Warn.....	7-9	ROM Fail .....	7-11
Fatal Crd.....	7-9	RT Int .....	7-11
Fixed Vel.....	7-9	RX Fail .....	7-11
Flow Switching.....	C-53	Sampler.....	7-11
FRQ O-Rnge.....	7-9	Scaling .....	7-11, 7-12
Gas CV .....	6-139	Seal Fail .....	7-12
Gas Properties.....	6-126	Sec OP Fxd.....	7-12
Gas Properties.....	6-92	Sec OP Sat .....	7-12
Gas Properties (Ultrasonic).....	6-149	Select.....	7-12
GOST CV .....	6-88	Self Calib .....	7-12
GOST Flow.....	6-89	Sens Fail.....	7-12
GPA2172.....	6-70	SGERG .....	6-74
H/W Fail .....	7-9	SICK Control .....	6-165
Hi .....	7-9	SICK Ultrasonic.....	6-165
High Prd .....	7-9	Slug Flow.....	7-12
Hi-Hi .....	7-9	Speed.....	7-12
I/P Err.....	7-9	Splits.....	7-12
Illegal.....	7-9	Station Limits.....	5-4
Integ-Fail .....	7-9	Stopped.....	7-12
Invalid Inc .....	7-9	Suppress Alarms in Maintenance.....	6-2
IP O-Rnge.....	7-9	Suppress Alarms in Maintenance for Streams.....	6-4
ISO5167.....	6-59	Suppress on Cutoff for Streams.....	6-5
ISO6976.....	6-70	Suppressing LogiCalc.....	15-28
ISO6976/GPA.....	6-115	Task Fail.....	7-12
K_Comp .....	7-9	Temp Fail.....	7-12
Limits.....	7-4	Testing LogiCalc .....	15-28
Linearisation.....	6-40, 6-130, 6-153, 6-168, 6-193, 6-219	Tot Corr.....	7-12
Link.....	7-9	Tot Part.....	7-12
		Tot Res.....	7-12
		Tot Roll Ovr.....	7-13

Tot Roll Udr.....	7-13	API1121M .....	
TPU Fail.....	7-13	.....	5-23, 5-36, 5-50, 6-173, 6-199, 6-207, 6-222
Tsk Err.....	7-13	Append .....	8-6
Tsk Of low .....	7-13	Append Page.....	13-3
Tx Config.....	7-13	Apply Splits.....	5-10, 6-31, 6-82, 6-122, 6-145
Tx Elec.....	7-13	Applying	
Tx Fail.....	7-13	Firewall Rule to a Range of IPs.....	G-3
Ultrasonic .....	6-158	Aromatics CCF.....	6-199, 6-222
Ultrasonic Control.....	6-162	Aromatics Type.....	6-199, 6-207, 6-222
Unavail.....	7-13	Arrange Icons .....	2-27
Undefined.....	7-13	ARRTXT .....	E-3
U-Range.....	7-13	ASCII.....	A-1
V-Cone.....	6-64	Assigning	
Warm St.....	7-13	Analog Inputs.....	4-6
Warn Ch_B.....	7-13	Discrete (Digital) Inputs.....	4-2
Warn Ch_C.....	7-13	Discrete (Digital) Outputs.....	4-5
Warn Ch_D.....	7-13	PID Loops .....	4-24
Warning.....	7-13	Pulse Outputs.....	4-22
Zero Div.....	7-14	Turbine Inputs.....	4-19
Zero High.....	7-14	Assignment.....	2-27, 6-110
Zero Low .....	7-14	ASTM.....	6-173
Zero Noise.....	7-14	Atm press (bara/psia).....	7-1
Zero Op.....	7-14	Auto Disable .....	5-15, 6-42, 6-132, 6-155
Zero Prog .....	7-14	Sampler Coriolis Liquid .....	6-171, 6-197, 6-216
Alarms pane.....	15-4	Auto Disable On Can Full.....	J-4
ALM_ACC .....	E-3	Auto Disable On Flow Status.....	J-4
ALM_CLR.....	E-3	Auto Disable On Flowrate Limit.....	J-4
ALM_SET.....	E-3	Auto hide unused Displays.....	7-21
Alpha		Auto Restart.....	5-15, 6-42, 6-132, 6-155, J-4
Coriolis Observed Density Correction.....	6-173	Sampler Coriolis Liquid .....	6-171, 6-197, 6-216
Coriolis Standard Density Correction.....	6-182	Auto Switch Modes .....	E-22
Turbine Observed Density Correction.....		Auto/Manual .....	4-24
.....	6-199, 6-222	Auto/Norm.....	5-10, 6-31, 6-82, 6-122, 6-145
Turbine Standard Density Correction.....	6-207	Automatic Failover.....	F-17
An Out Channel .....	4-24	Automatic Polling.....	11-2
Analog.....	4-23	Available Alarms.....	7-4
Analog I/P .....		Average.....	6-241
.....	6-42, 6-132, 6-155, 6-171, 6-197, 6-216	Average Temp & Pressure.....	5-4
Analog Input .....	4-6	Average Density.....	6-241
Analog Output.....	4-15	Average Method	
Analogue.....	A-1	Provers.....	B-66
Analogue (Analog) Inputs		Averaging	
Assigning.....	4-6	Flow-weighted (FWA).....	6-19
BSW .....	6-213, 6-236	Mode.....	5-4
Calibration Requirements .....	D-1	Stations .....	5-4
Editing.....	4-7	Time-weighted (TWA) .....	6-20
Object (ADC).....	D-4, D-7	AV-MN/AV.....	B-40, B-74, B-104
Analogue (Analog) Outputs		AWG .....	A-1
Editing.....	4-15	<b>B</b>	
PID Loop Settings.....	4-24	Bad Pulse	
Analogue Output		Configuration.....	4-19
Calibration.....	D-10	Reset Mode.....	4-19
Calibration Control Requirements .....	D-10	Bad Pulse Alarm.....	7-6
Analysing a Configuration.....	2-17	Ball Prover.....	5-20
Analysis Timeout....	5-10, 6-31, 6-82, 6-122, 6-145	Alarm Limits .....	5-31
ANIN.....	A-1	Constants.....	5-23
Annubar.....	2-8, 6-66, A-1	Flow Balance Setup.....	5-18
Annubar (Mass Flowrate).....	6-66	Hardware.....	5-30
Annubar Base Temp.....	6-66	Run Data .....	5-21
Annubar Diamond 11 + 1998 .....	6-66	Ball provers .....	B-2
ANOUT.....	A-1	bar - in H2O (@60F) .....	7-1
ANSI.....	A-1		

bar - kPa..... 7-1  
 bar - psi ..... 7-1  
 Base Compressibility (Zb).....  
 ..... 6-56, 6-68, 6-74, 6-77, 6-112  
 Ultrasonic Gas..... 6-136  
 Base Conditions  
 Pressure.....6-68  
 Temperature .....6-68  
 Base Density (DT)..... 6-36,  
 6-56, 6-68, 6-74, 6-78, 6-92, 6-112, 6-119, 6-143  
 BSW ..... 6-213, 6-236  
 Coriolis Observed Density Correction..... 6-173  
 Coriolis Standard Density Correction..... 6-182  
 RHOc.....6-88  
 Turbine Gas..... 6-126  
 Turbine Observed Density Correction.....  
 ..... 6-199, 6-222  
 Turbine Standard Density Correction..... 6-207  
 Ultrasonic Gas..... 6-136  
 Base K Factor  
 Master Meter Constants .....5-50  
 Base Pressure..... 6-80, 6-149  
 Base Sediment and Water (BSW)..... 6-213, 6-236  
 Base Temperature.....6-80  
 Base Time  
 Add Report to a Configuration.....3-11  
 Base Time Reports..... 3-8  
 Base Values  
 Ball Prover Constants .....5-23  
 Base Viscosity .....6-68  
 Base Volume  
 Compact Prover Constants.....5-36  
 Basetime..... A-1  
 Batch control ..... A-1  
 Batch Recalculation..... C-32  
 Batch Stack Slot Edit Commands (Front Panel  
 Display)..... C-59  
 Batch Stack Slot Edit Commands (Webserver).....  
 ..... C-65  
 Batches  
 Recalculating..... C-32  
 Batching ..... 2-8, C-2, E-19  
 Alarms..... C-30  
 Batch Sequence and Control ..... C-19  
 Retrospective Batch Totals..... C-29  
 Screen ..... C-8  
 ScreenStation..... C-8  
 Sequence and Control ..... C-19  
 Sequence Stages..... C-20  
 Setup ..... C-8  
 Stages..... C-20  
 Station Sequence Stage Descriptions..... C-21  
 Station Stand Alone Stages ..... C-26  
 Stream Standalone Stages ..... C-28  
 Stream Supervised Stages..... C-29  
 Supervised Station Stages..... C-27  
 Ticket..... C-30  
 Batt Fail Alarm..... 7-6  
 Baud ..... A-1  
 Baud rate..... A-1  
 Baud Rate..... 9-5, F-4  
 Behaviour..... 4-9  
 Beta.....6-59, 6-64, 6-80, 6-89

B-Fail Alarm..... 7-6  
 Bi-di proving  
 Communications ..... B-3  
 Inputs ..... B-3  
 Outputs..... B-3  
 Pulse interpolation..... B-5  
 Pulse measurement..... B-4  
 Sphere switch interface..... B-5  
 Bi-Directional Prover ..... 5-20  
 Bi-directional proving..... B-2  
 Binary ..... A-1  
 Bit ..... A-1  
 Bit link (jumper) ..... A-1  
 Bit switch..... A-2  
 Block Valves..... 6-16  
 Valve Setup Type..... 6-16  
 Valve Timings ..... 6-16  
 Blocked Alarm..... 7-6  
 Breakpoint..... 15-14  
 BSW  
 Parameters ..... 6-213, 6-236  
 Btu - J..... 7-1  
 Buffer..... A-2  
 Bus ..... A-2  
 Buttons ..... 2-27  
 System Editor Icon Bar..... 8-6  
 Bytes ..... A-2

**C**

Calc Explorer Options ..... 7-23  
 Calc Explorer..... 2-27, 7-22  
 Add All Inputs ..... 7-26  
 Add All Outputs..... 7-27  
 Adding an Item..... 7-24  
 Button..... 8-6  
 Save as Bitmap..... 7-29  
 Calc Fail Alarm..... 7-7  
 Calc Select  
 BSW..... 6-213, 6-236  
 CALC/ALM Auto Switch Modes..... E-22  
 CALC/ALM Modes (MODE TAB CALC)..... E-22  
 CALCALMITEM..... E-4  
 Calculated ..... 6-241  
 Calculated MF versus Avg of Previous Historical  
 MFs ..... B-75  
 Calculated MF versus Initial Base MF . B-75, B-105  
 Calculated Output..... 6-62  
 Calculated Pressure  
 Ball Prover Constants ..... 5-23  
 Calculated Temperature  
 Ball Prover Constants ..... 5-23  
 Calculation Limit Check ..... 6-59, 6-89  
 Calculation Limits ..... 6-25, 6-40, 6-53, 6-56, 6-64,  
 6-66, 6-68, 6-69, 6-74, 6-77, 6-78, 6-80, 6-112,  
 6-115, 6-168  
 Turbine Gas ..... 6-130  
 Turbine Liquid..... 6-193, 6-219  
 Ultrasonic Control..... 6-162  
 Ultrasonic Gas ..... 6-153  
 Ultrasonic Gas ..... 6-136, 6-139  
 Ultrasonic Gas ..... 6-158  
 Calculation Parameters ..... 6-25, 6-69, 6-115



Ultrasonic Gas.....	6-139	Cell	
Calculation Results.....	4-15	3 Identical .....	6-106
Turbine Observed Density Correction.....		Hi Hi.....	6-97
.....	6-199, 6-222	Lo Hi .....	6-96
Turbine Standard Density Correction.....	6-207	Lo Hi Hi.....	6-102
Calculation Results Limits.....	6-59, 6-89	Lo Mid Hi .....	6-98
Calculation Type.....	6-39, 6-59, 6-64, 6-68, 6-80	Single.....	6-95
Calculation Type Modified .....	6-77	Cell Input Stacking.....	6-95
Calculation Version.....	6-64, 6-66	CFX files and time stamps .....	H-7
1991 .....	6-59	CFX Reporting	
GOST8563 97.....	6-89	Adding reports .....	H-1
Calculations		Changing CFX settings .....	H-4
Provers.....	B-34, B-66	Enabling reports.....	H-3
Calibrated Diameter.....	6-53	File structure.....	H-8
Calibrated Temperature.....	6-53	Generating from the web browser .....	H-5
Compact Prover Constants.....	5-36	Regenerating the report template.....	H-5
Calibration		Changing PC clock .....	1-11
Analogue Input .....	D-3	Channel .....	4-23
Analogue Input Requirements .....	D-1	Characteristics .....	6-89
Analogue Output.....	D-10	Check.....	6-241
Control Requirements.....	D-2	Check Critical Alarms.....	
DAC Device .....	D-11	.....	5-10, 6-31, 6-82, 6-122, 6-145
Field Calibration.....	D-1	Check Deviations ..	5-10, 6-31, 6-82, 6-122, 6-145
Linear Two-point ADC Device.....	D-3	Check Non Critical Alarms.....	
Linear Two-point Device PRT.....	D-8	.....	5-10, 6-31, 6-82, 6-122, 6-145
Non-linear Three-point Curve Calibration Control		Check Limits	
Mechanism .....	D-7	Coriolis Gas Composition ..	5-10, 6-31, 6-82, 6-122
Offset PRT Calibration Control Mechanism ....	D-8	Ultrasonic Gas Composition.....	6-145
Offset PRT Device Calibration.....	D-8	Check Mode Selection.....	E-19
Operator Interface.....	D-3	Checksum.....	7-20, 9-3
Pressure.....	6-238	Chromat.....	6-241
PRT/RTD.....	4-13, 4-14	Communications ...	5-10, 6-31, 6-82, 6-122, 6-145
Temperature .....	6-238	Processing .....	5-10, 6-31, 6-82, 6-122, 6-145
call		Slave Address .....	2-16
LogiCalc Editor.....	15-25	Telemetry.....	5-10, 6-31, 6-82, 6-122, 6-145
Calorific Value .....	6-25, 6-30, 6-139	Chromatograph.....	5-10, 6-31, 6-82, 6-122, 6-145
AGA5.....	6-69	Chromatographs.....	K-1
GPA2172.....	6-115	Chronometry	
ISO6976.....	6-115	P154 Dual Chronometry Switch Pair.....	E-20
Calorific Value (AGA5).....	6-25, 6-30	Clone	
Can		Config Organiser.....	2-30
Can Fill Indicator.....	5-15, 6-42, 6-132, 6-155	Close.....	2-27
Sampler Coriolis Liquid..	6-171, 6-197, 6-216	Close O/P.....	4-5
Can Fill Period.....	5-15, 6-42, 6-132, 6-155	CO2 Content.....	6-68
Sampler Coriolis Liquid..	6-171, 6-197, 6-216	Code .....	15-2
Can High High Limit.....	5-15, 6-42, 6-132, 6-155	Coefficient a to c.....	6-53
Sampler Coriolis Liquid..	6-171, 6-197, 6-216	Coefficient Linear Expansion.....	6-66
Can High Limit.....		Cold start.....	A-2
..	5-15, 6-42, 6-132, 6-155, 6-171, 6-197, 6-216	Cold Start Alarm.....	7-7
Can Limits.....	5-15, 6-42, 6-132, 6-155	Columns	
Sampler Coriolis Liquid..	6-171, 6-197, 6-216	System Editor.....	8-8
Can Low Limit.....	5-15, 6-42, 6-132, 6-155	Combustion Heat	
Sampler Coriolis Liquid..	6-171, 6-197, 6-216	Hcb .....	6-88
Can Volume.....	5-15, 6-42, 6-132, 6-155	Hch.....	6-88
Sampler Coriolis Liquid..	6-171, 6-197, 6-216	COMMIT .....	G-3
Can Fill Digital Input.....	J-4	Committing the Firewall Rules .....	G-3
Can Fill Grab Count.....	J-4	Common	
Can Fill Indicator Analogue Input .....	J-4	Common Links.....	4-30
Can Full Alarm.....	7-7	Common Stream Settings.....	6-4
Can High Alarm.....	7-7	Coriolis Gas Composition ..	5-10, 6-31, 6-82, 6-122
Carbon St.....	6-53	Ultrasonic Gas Composition.....	6-145
Cascade .....	2-27	Common Alarm.....	7-7
CATS .....	A-2	Common File Exchange (CFX) .....	H-1

Common Stream		Accessing .....	1-8
Flowrate Limits .....	6-5	Activating .....	1-9
Weighted Average.....	6-18	Lite.....	1-3
Comms.....	4-31	Lite Plus.....	1-3
Comms Link .....	4-31	Pro.....	1-4
Comms Properties		Configuration .....	1-4, 9-1, 15-5
Remote Archive Uploader.....	11-7	I/O .....	2-4
Communication.....	4-30	Measurement Units.....	2-3
Communications .....	4-1, 9-4, 14-1	Naming.....	2-2
Bi-di proving.....	B-3	Saving .....	2-29
Coriolis.....	6-45, 6-189	Stations .....	2-5
Defining.....	2-16	Streams.....	2-8
Editing Communications Port.....	4-30	Configuration screens .....	2-26
Master Meter Prover.....	B-78	Configuration Wizard.....	2-1
Port.....	4-30	Step 1 of 6 Name Configuration.....	2-2
Provers.....	B-43, B-78	Step 2 of 6 Select Measurement Units.....	2-3
Qsonic.....	6-163	Step 3 of 6 Specify I/O .....	2-4
Set up Peer-to-Peer.....	F-4	Step 4 of 6 Define Stations .....	2-5
Tasks.....	7-15	Step 5 of 6 Define Streams .....	2-8
Ultrasonic Control.....	6-162	Step 6 of 6 Define Communications .....	2-16
Compact Folder Format.....	11-15	Configurations	
Compact Prover.....	5-32	Adding a Base Time Report .....	3-11
Alarm Limits .....	5-44	Advanced Setup.....	7-1
Constants .....	5-36	Analysing .....	2-17
Hardware.....	5-43	Format.....	2-23, 15-2
Prover.....	B-42	Initial Stream .....	6-2
Run Data.....	5-34	Managing Reports .....	3-13
Company Address.....	3-2	New Button .....	2-27
Company Fax.....	3-2	Opening an Existing.....	2-23
Company Information.....	3-2	Save Button.....	2-27
Company Telephone.....	3-2	Send .....	9-6
Compile.....	15-14	Station.....	5-1
Complete Alarm.....	7-7	Streams.....	6-2
Compress .....	6-241	Updates.....	1-1
Compressibility .....		Version.....	2-23, 15-2
.....	6-23, 6-56, 6-112, 6-119, 6-136, 6-143	Configure	
AGA3.....	6-80	Automatic Polling .....	11-2
AGA8.....	6-56, 6-112	Manual Polling.....	11-6
NX19.....	6-77	Configuring	
PTZ .....	6-78	Communications Port on your USB	
SGERG.....	6-74	Communications Port.....	10-2
Computer Alarms .....	7-4	Disabling Remote Front Panel.....	10-8
Conf CSum Alarm .....	7-7	PC WITH a Native Serial Communications Port	
Conf Err Alarm.....	7-7	.....	10-3
Config Alarm.....	7-7	PC without a Native Serial Communications Port	
Config Chg Alarm.....	7-7	.....	10-1
Config Created.....	3-3	S600+ to Use the Remote Front Panel.....	10-4
Config Format.....	3-3	Set up Peer-to-Peer Options .....	F-4
Config Format 8.....	3-2	Configuring the Batch Stack Through the Front	
Config Last Edited .....	3-3	Panel Display .....	C-58
Config Organiser.....	2-27, 2-30	Configuring the Batch Stack Through the System	
Clone.....	2-30	Editor.....	C-56
Delete .....	2-30	Configuring the Next Batch.....	C-38
Move Down.....	2-30	CONFTAB.....	E-6
Move Up.....	2-30	connect.....	15-25
Rename.....	2-30	LogiCalc Editor .....	15-25
Config Transfer.....	9-1	Connect (const).....	15-9
Button .....	2-27	Connect Wizard.....	7-24, 15-4
Enabling PCSetup Link .....	9-2	Connecting	
Licensing.....	9-10	S600+ via Serial Cable.....	9-2
Send Configuration.....	9-6	const .....	15-8, 15-9, 15-10
Config Version.....	3-2	Const Statement	
Config600.....	1-1, 1-3, A-2	LogiCalc Editor .....	15-24

Constants.....	7-1, 15-8, A-2	CTSM For Spool	
Ball Prover.....	5-23	Ultrasonic Gas.....	6-158
Compact Prover.....	5-36	CUMTOT.....	E-6
Editing Conversions/Constants.....	7-1	Cumulative Totals.....	4-22
Master Meter Prover.....	5-50	Cut.....	2-27, 8-6
Contents.....	2-27	Cut Display.....	13-8
Control Action.....	4-24	Cut Off Mode.....	E-19
Control bus.....	A-2	CV.....	6-139
Control Limits		CV	
Flow Switching and Flow Balancing for Streams ..		CV AGA5.....	2-8
.....	6-5	CV GOST.....	2-8
Streams.....	6-5	CV GPA2172.....	2-8
Conversion.....	4-15, 4-24	CV ISO6976.....	2-8
Analog.....	4-10, 4-13	CV Table.....	6-25, 6-69, 6-115
Convert Density Units from Kgm3.....	15-19	CV	
Convert Density Units to Kgm3.....	15-18	Ultrasonic Gas.....	6-139
Convert Temperature Units.....	15-18	CV.....	6-241
PRT/RTD.....	4-12	CV	
Conversions/Constants.....	3-3, 7-1	CV Vol Units.....	7-17
Editing Conversions/Constants.....	7-1	CV.....	A-2
Copy.....	2-27, 8-6	CVAGA5.....	6-30
Copy Display.....	13-8	CVOL Fail Mode.....	6-119, 6-143
Coriolis.....	2-8, 6-45, 6-189	CVOL Flowrate.....	6-80
Communications.....	6-45, 6-189	<b>D</b>	
Gas.....	6-22, 6-45	DAC.....	A-2
Gas Composition.....	5-10, 6-31, 6-82, 6-122	DAC Control Mechanism.....	D-12
Gas Properties.....	6-36	DAC Device Calibration.....	D-11
Liquid.....	6-167, 6-189	Analogue Input.....	D-11
Observed Density Correction.....	6-173	DACOUT.....	E-6
Standard Density Correction.....	6-182	Daniel Liquid Ultrasonic.....	6-238
Validation Logic.....	6-48	Communications.....	6-238
CORR DENS.....	6-50	Control Data.....	6-238
Corrected.....	6-241	Flow Source Selection.....	6-238
Corrected Orifice Diameter.....	6-53	Meter Variable Limits.....	6-238
Corrected Pipe Diameter.....	6-53	Pressure Source.....	6-238
Corrected Volume.....	7-17	Serial Flow Type.....	6-238
Correction Type.....	6-50	Temperature Source.....	6-238
Corrections		Data.....	8-8
Ultrasonic Gas.....	6-158	System Editor.....	8-8
CPL Calculation		Data Bits.....	9-5, F-4
Ball Prover Constants.....	5-23	Data Index	
Compact Prover Constants.....	5-36	LogiCalc Editor.....	15-25
Coriolis Observed Density Correction.....	6-173	Data Integrity	
Coriolis Standard Density Correction.....	6-182	Remote Archive Uploader.....	11-17
Master Meter Constants.....	5-50	Data Items	
Turbine Observed Density Correction.....		Data Item Security.....	7-17
.....	6-199, 6-222	Data Point.....	13-6
Turbine Standard Density Correction.....	6-207	Adding.....	12-7
CPSM for Spool		Editing.....	12-9
Ultrasonic Gas.....	6-158	Data points.....	14-5
CPU.....	A-2	Data Points	
CRC Fail Alarm.....	7-7	Assignment Button.....	2-27
Creating		Display Editor.....	13-5
LogiCalc.....	15-5	Security.....	7-17
New Configuration.....	2-1	Data Tout Alarm.....	7-8
Streams.....	2-8	Data Type	
Critical Alarm.....	7-7	LogiCalc Editor.....	15-25
cst - mm2s.....	7-1	Database	
CTL Temperature		Objects.....	8-4
Ball Prover Constants.....	5-23	Objects and Fields.....	E-2
CTL_CPL.....	A-2	S600+.....	8-3
CTS.....	A-2		

Tables.....	8-4, 8-5	Derivative Action (D) .....	4-30
Database Fields.....	E-18	Derivative Time.....	4-24
Databus.....	A-2	Description.....	4-2, 4-9, 4-18, 4-21, 4-22
Daylight Savings changes.....	1-11	LogiCalc Editor .....	15-2
DCS.....	A-2	Detail.....	6-56, 6-136
DCU.....	A-2	Dev Err Alarm.....	7-8
Debug .....	15-14	Dev Open Alarm.....	7-8
Debugging a LogiCalc Remotely.....	15-16	Deviation.....	4-9
Passing an Object from the Duty to the Standby		DF.....	6-74
S600+ .....	F-14	DI.....	A-2, A-3
Decimal Places.....	13-5	Diagnostics.....	7-21
Defaults		DIAM Units.....	7-17
Time .....	3-16	Differential Pressure	
Defining		Cell Input .....	6-126
Communications.....	2-16	DIG I/P.....	6-42, 6-132, 6-155, 6-171, 6-197, 6-216
Streams.....	2-8	DIGIO.....	E-6
DEG C - K.....	7-1	Setup Table.....	E-19
DEG.API.....	5-23, 5-36, 5-50	Digital Inputs.....	4-2
Delete.....	8-6, 14-8	dim.....	15-6
Config Organiser.....	2-30	LogiCalc Editor .....	15-24
Deleting		DIN .....	A-3
Delete Line.....	12-6	Directory Settings.....	11-12
Levels .....	7-16	Disabling	
Passwords.....	7-16	Remote Front Panel.....	10-8
Reports .....	3-13	Discharge Coefficients.....	6-59, 6-80, 6-89
Security.....	7-16	Discrep Alarm .....	7-8
Deleting a Modbus Data Point.....	14-8	Discrepancy.....	6-110, A-3
Deleting Report Lines.....	12-10	Discrete Inputs.....	4-2
Denied Alarm.....	7-8	Adding.....	4-4
Dens A.....	6-241	Assigning.....	4-2
Dens B.....	6-241	Editing.....	4-3
Dens Exp Constant.....	6-50	Discrete Outputs.....	4-5
Dens Limit Alarm.....	7-8	Assigning.....	4-5
Dens Units .....	7-17	Display	
Densitometer.....	2-8, A-2	system graph.....	7-22
Densitometer Input		Display Editor.....	13-1
Density Measurement.....	6-13	Accessing.....	13-1
Specified Gravity.....	6-13	Append Page.....	13-3, 13-5
Densitometers .....	4-17	Button.....	2-27
Density.....	6-45, 6-50, 7-1	Data Point.....	13-5
Coriolis.....	6-189	Decimal Places.....	13-5
Density and CV.....	6-119, 6-143	Displays.....	13-8
Density Compressibility (Zd).....	6-77	Edit Line .....	13-3, 13-5
Density Pressure (P2).....	6-77	Editing.....	13-3
Density Temperature (T3).....	6-77	Exponential Format.....	13-5
Failure Modes.....	6-242	Help .....	13-3
Transducer Modes (MODE TAB DENS IP)...	E-22	Insert Menu.....	13-3, 13-5
Density Calibration Pressure.....	6-45	Insert Page.....	13-3, 13-5
Coriolis.....	6-189	Insert/Append Page.....	13-5
Density Inputs.....	4-17	Leading Zeros.....	13-5
Editing.....	4-18	Limits .....	13-5
Density Measurement.....	6-13	Menu/Page.....	13-3
Observed Density.....	6-13	Menu/Page Clipboard .....	13-8
Density Table Units		Navigating.....	13-2
Coriolis Observed Density Correction.....	6-173	Page Clipboard.....	13-8
Coriolis Standard Density Correction.....	6-182	Regenerating Displays.....	13-8
Turbine Observed Density Correction.....		Save.....	13-3
.....	6-199, 6-222	Text.....	13-5
Turbine Standard Density Correction.....	6-207	Translate.....	13-3, 13-7
Density Units		Displays.....	2-27, 7-20, 7-21, F-26
Ball Prover Constants.....	5-23	Editing.....	7-21
Compact Prover Constants.....	5-36	Displays/Webserver.....	7-15
Master Meter Constants.....	5-50	Editing.....	7-21

Documents	
Config600 Configuration Software User Manual (A6169)	1-11
S600+ Flow Computer Product Data Sheet (S600+)	1-11
S600+ Flow Manager Instruction Manual (A6115)	1-11
DOSETUP	E-7
Downloading	
Verifying the Peer to Peer Link	F-28
Downstream Density	6-50
Downstream Pressure	6-59, 6-89
Downstream/Upstream Correction	6-50
DP	2-8, A-3
Cell Input	6-95
Cell Input Stacking	6-95
Cut Off Mode	E-19
DP Cell Input Conditioning Screen	6-110
DP Cell Type Flange	6-80
Gas	6-50
Gas Properties	6-92
GOST Flow	6-89
Live/Check Mode Selection	E-19
Modes (MODE TAB DP STACK)	E-22
Stack Type	E-19
Units	7-17
DP Cell Input Conditioning	6-95
DP Stacks	4-15
DPCCELL	E-7
DPR	A-3
DRAM	A-3
Drv Gain Alarm	7-8
Dscrp Alarm	7-8
DT TO BASE	6-173
Dual Chronometry	5-30, 5-43
Ball Prover Hardware	5-30
Compact Prover Constants	5-43
Dual Chronometry Switch Pair	E-20
Dual Ethernet Module	2-4
Dual Ethernet System	4-34
Dual Ethernet Systems	4-30
Dual Level A	4-19
Dual Level B	4-19
Duty / Standby	F-1
DVC	A-3
DYN VISC Units	7-17
<b>E</b>	
E Format	A-3
Edit	8-8
Edit Displays	2-27
Edit Line	13-3
Edit Menu	2-27
Edit Placement	12-6, 12-9
Edit line	13-5
Editing	
Alarms	7-4
Analog Inputs	4-7
Analog Outputs	4-15
Communications Port	4-30
Constants	7-1
Conversions/Constants	7-1
Density Inputs	4-18
Discrete (Digital) Inputs	4-3
Display Editor	13-3
Displays/Webserver	7-21
Edit Line	13-5
Edit Placement	12-6
Edit Security	2-27
Flowrates	5-2
HART Boards	4-23
Levels	7-16
Passwords	7-16
Reports	3-13
Security	7-15, 7-16
System Editor	8-8
Totals Descriptors	7-3
Turbine Inputs	4-21
Editing a Data Point	12-9
Editing Modbus Register Format	14-8
Editor	
Display	13-1
Modbus	14-1, 14-2
Placement	12-7
Report	12-1
Transfer	9-1
EEPROM	A-3
EEProm Alarm	7-8
Elasticity	
Ball Prover Constants	5-23
Compact Prover Constants	5-36
Email Codes	1-9
Enabling	
Automatic Operation	11-6
PC Setup Link	9-2
Peer-to-Peer Link	F-3
Energy	7-1, 7-17
Energy Fail Mod	6-119, 6-143
Energy Ration (Ev/Em)	6-25, 6-30
Engineering Values	3-3, 7-17
Equilibrium Vapour Pressure (Pe)	6-199, 6-222
Error	
Error Check Frequency	4-19
Error Percent	6-130, 6-153, 6-158
Error Alarm	7-8
Ethernet	A-3
Ethernet Module	2-4
Ethylene	6-39
BASE COMP(Zb)	6-39
Base Conditions	6-39
BASE DENSITY	6-39
Calculation Limits	6-39
Calculation Type	6-39
Flowing Conditions	6-39
METER DENSITY	6-39
UPSTR COMP(Zb)	6-39
EU	A-3
Event 1 Alarm	7-8
Event 2 Alarm	7-8
Event Archive Size	7-4
Event History Type	E-19
Event Logging	11-1
EVENTHIST	E-8
Example LogiCalcs	15-2

Examples	
LogiCalc Editor.....	15-16
Exception Alarm.....	7-8
exf wall.txt.....	G-1
Exit .....	2-27
exp(x)	
LogiCalc Editor.....	15-27
Expansion Factor .....	6-64, 6-80, 6-89
Calc Type .....	6-64
Discharge Coeff.....	6-59
Exponent .....	A-3
Exponential Format.....	13-5
Extended Folder Format.....	11-15
External	
Ultrasonic Gas.....	6-158
External Access .....	7-20
<b>F</b>	
Factors .....	6-59, 6-64, 6-66, 6-89
Fail A Alarm.....	7-8
Fail B Alarm.....	7-8
Fail CH_A Alarm .....	7-8
Fail CH_B Alarm .....	7-9
Fail CH_C Alarm.....	7-9
Fail CH_D Alarm.....	7-9
Fail Warn Alarm.....	7-9
Failure Modes	
Density.....	6-242
Fatal Crd Alarm.....	7-9
Fault Totals .....	6-119, 6-143
FFactor	
Coriolis Observed Density Correction.....	6-173
Coriolis Standard Density Correction.....	6-182
Turbine Observed Density Correction....	6-199, 6-222
Turbine Standard Density Correction.....	6-207
Field Calibration.....	D-1
Field Name	
LogiCalc Editor.....	15-25
Figures	
1-1. Config Upgrade dialog.....	1-2
1-2. License Agreement.....	1-6
1-3. Choose Components.....	1-6
1-4. Install Locationg.....	1-7
1-5. Installation Progress.....	1-7
1-6. Installation Complete.....	1-8
1-7. Config600 Menu.....	1-9
1-8. Config600 Activation Screen.....	1-10
2-1. Config600 Welcome.....	2-1
2-2. Configuration Generator, Step 1.....	2-2
2-3. Configuration Generator, Step 2.....	2-3
2-4. Configuration Generator, Step 3.....	2-4
2-5. Configuration Generator, Step 4.....	2-5
2-6. Gas Station Option Summary .....	2-6
2-7. Gas Station Options Summarized.....	2-7
2-8. Liquid Station Options Summary screens	2-7
2-9. Configuration Generator, Step 5.....	2-9
2-10. Gas Stream Options Summary.....	2-10
2-11. Gas Stream Options Summarized.....	2-13
2-12. Liquid Stream Options Summary .....	2-14
2-13. Liquid Stream Options Summarized .....	2-15
2-14. Configuration Generator, Step 6.....	2-16
2-15. Generating Config dialog box.....	2-17
2-16. Example System Graphic .....	2-17
2-17. System Graphic (Stations and Streams).....	2-18
2-18. Stream Values (expanded).....	2-18
2-19. Value selection (expanded).....	2-19
2-20. Input Values (expanded).....	2-20
2-21. Input Values (assigned).....	2-21
2-22. Selectable icons.....	2-22
2-23. Select Config.....	2-23
2-24. Configuration-specific System Graphic	2-25
2-25. PCSetup Editor.....	2-26
2-26. Config Organiser.....	2-31
3-1. System Setup screen.....	3-1
3-2. Versions screen.....	3-2
3-3. Units screen.....	3-4
3-4. Reports screen.....	3-6
3-5. Archive Configuration dialog box .....	3-10
3-6. Archive Configuration .....	3-12
3-7. Managing Configurations.....	3-13
3-8. Totalisation .....	3-14
3-9. Totals Detail dialog.....	3-15
3-10. Date/Time Parameters .....	3-16
4-1. Typical I/O Setup Screen (Discrete Inputs	
Shown).....	4-2
4-2. Digital Input Selection dialog box .....	4-3
4-3. Edit Description dialog box .....	4-4
4-4. Digital Input Selection (New I/O Point).....	4-4
4-5. Digital Output Selection dialog box.....	4-5
4-6. Analog Input Assignment dialog box.....	4-6
4-7. Analog Input, PRT/RTD, and HART dialog	
boxes .....	4-8
4-8. Analog Input Assignment dialog box.....	4-15
4-9. Analog Output Items.....	4-16
4-10. I/O Channels for Density Input.....	4-17
4-11. Alarm Reminder.....	4-18
4-12. Edit Description dialog box.....	4-18
4-13. Pulse Input Assignment dialog box.....	4-19
4-14. Edit Description dialog box.....	4-21
4-15. Pulse Output Items .....	4-21
4-16. Pulse Output Items .....	4-22
4-17. HART Module Configuration screen ....	4-23
4-18. PID Loop Enabled screen.....	4-24
4-19. Analog Output Assignment screen.....	4-24
4-20. PID Loop Output Assigned screen .....	4-25
4-21. PID Loop Output Assigned screen .....	4-25
4-22. PID Loop PV Assigned screen.....	4-26
4-23. Example Communication Task	
Configurations .....	4-31
5-1. Stations on the Hierarchy Menu.....	5-1
5-2. Flowrate Options.....	5-3
5-3. Calculation Result dialog box .....	5-3
5-4. Calculation Result (with limits).....	5-4
5-5. Flowrate Alarms with Limits .....	5-4
5-6. Average Temperature & Pressure.....	5-5
5-7. Calculation Result dialog box .....	5-5
5-8. Secondary Units STN Setup .....	5-6
5-10. Dual Units Setup – Periodic Totals dialog	
box.....	5-8
5-11. Flow Switching screen.....	5-9
5-12. Station Gas Composition screen.....	5-10
5-13. Station Sampling.....	5-16
5-14. Flow Balance Setup screen.....	5-19

5-15. Run Data screen (Ball Prover).....	5-21	6-37. SGERG (Compressibility) screen.....	6-75
5-16. Constants screen (Ball Prover).....	5-24	6-38. NX19 (Compressibility) screen.....	6-77
5-17. Hardware screen (Ball Prover).....	5-30	6-39. PTZ (Compressibility) screen.....	6-79
5-18. Alarm Limits screen (Ball Prover).....	5-32	6-40. AGA3 (Volume Flowrate) screen.....	6-80
5-19. Run Data screen (Compact Prover).....	5-34	6-41. Gas Composition screen.....	6-82
5-20. Constants screen (Compact Prover).....	5-37	6-42. Z Steam (Compressibility) screen.....	6-87
5-21. Hardware screen (Compact Prover).....	5-43	6-43. GOST CV screen.....	6-88
5-22. Alarm Limits screen (Compact Prover).....	5-44	6-44. GOST Flow screen.....	6-90
5-23. Run Data (MMeter Prover).....	5-47	6-45. Gas Properties screen.....	6-92
5-25. Constants screen (MMeter Prover).....	5-50	6-46. Lo Hi Cell Input Handling.....	6-96
5-25. Hardware screen (MMeter Prover).....	5-56	6-47. Lo Hi Cell Input Handling Flowchart.....	6-97
5-26. Alarm Limits screen (MMeter Prover).....	5-57	6-48. Hi Hi Cell Input Handling Flowchart.....	6-98
5-9. Dual Units Setup – Cumulative Totals dialog box.....	5-7	6-49. Lo Mid Hi Cell Input Handling.....	6-99
6-1. Stream Hierarchy screen.....	6-3	6-50. Lo Mid High Cell Input Handling Flowchart .. .....	6-100
6-2. General Settings.....	6-4	6-51. Lo Mid Hi Cell Input Handling Flowchart.....	6-101
6-3. Alarm Suppression dialog box.....	6-5	.....	6-101
6-4. Flowrate Settings.....	6-6	6-52. Lo Mid Hi Cell Input Handling Flowchart.....	6-101
6-5. Calculation Result dialog box.....	6-6	.....	6-101
6-6. Alarm Suppression dialog box.....	6-7	6-53. Lo Mid Hi Cell Input Handling Flowchart.....	6-102
6-7. Secondary Units STR Setup.....	6-8	.....	6-102
6-10. Flow Switching screen.....	6-11	6-54. Lo Hi Hi Cell Input Handling.....	6-103
6-100. Standard Density Correction screen.....	6-207	6-55. Lo Hi Hi Cell Input Handling Flowchart (1)...	6-104
6-101. BSW screen.....	6-214	.....	6-104
6-102. Local Units screen.....	6-215	6-56. Lo Hi Hi Cell Input Handling Flowchart (2)...	6-105
6-103. Sampling screen.....	6-217	.....	6-105
6-104. Linearisation screen.....	6-220	6-57. Lo Hi Hi Cell Input Handling Flowchart (3)...	6-105
6-105. Observed Density Correction screen.....	6-223	.....	6-105
6-106. Standard Density Correction screen.....	6-230	6-58. Lo Hi Hi Cell Input Handling Flowchart (4)...	6-106
6-107. BSW screen.....	6-237	.....	6-106
6-108. Daniel Liquid Ultrasonic screen.....	6-238	6-59. 3 Identical Cell Input Handling Flowchart (1)	6-107
6-11. Gas Component Flow Weighted Averaging screen.....	6-12	.....	6-107
6-12. Density Measurement Calculation Limits screen.....	6-14	6-60. 3 Identical Cell Input Handling Flowchart (2)	6-108
6-13. Density Measurement Densitometer screen .....	6-15	.....	6-108
6-14. Block Valves screen.....	6-17	6-61. 3 Identical Cell Input Handling Flowchart (3)	6-108
6-15. Time & Flow Weighted Averaging Example .....	6-19	.....	6-108
6-16. Weighted Averaging screen.....	6-21	6-62. 3 Identical Cell Input Handling Flowchart (4)	6-108
6-17. AGA8 (Compressibility) screen.....	6-23	.....	6-108
6-18. Gas CV screen.....	6-26	6-63. 3 Identical Cell Input Handling Flowchart (5)	6-108
6-19. Calorific Value screen.....	6-31	.....	6-108
6-20. Gas Composition screen.....	6-32	6-64. 3 Identical Cell Input Handling Flowchart (6)	6-109
6-21. Gas Properties screen.....	6-37	.....	6-109
6-22. Ethylene screen.....	6-39	6-65. 3 Identical Cell Input Handling Flowchart (7)	6-109
6-23. Linearisation screen.....	6-41	.....	6-109
6-24. Stream Sampling screen.....	6-43	6-66. 3 Identical Cell Input Handling Flowchart (8)	6-109
6-25. Coriolis screen.....	6-46	.....	6-109
6-26. Local Units screen.....	6-49	6-67. 3 Identical Cell Input Handling Flowchart (9)	6-109
6-27. Temperature/Pressure Correction screen.... .....	6-51	.....	6-109
6-28. Density Correction screen.....	6-51	6-68. DP Cell Input Conditioning screen.....	6-110
6-29. Pipe Correction screen.....	6-53	6-69. AGA8 screen.....	6-112
6-30. AGA8 (Compressibility) screen.....	6-57	6-70. Gas CV screen.....	6-115
6-31. ISO5167 (Mass Flowrate) screen.....	6-60	6-71. AGA7 screen.....	6-120
6-32. ISOTR9464 screen.....	6-63	6-72. Gas Composition screen.....	6-122
6-33. VCone (Mass Flowrate) screen.....	6-64	6-73. Gas Properties screen.....	6-127
6-34. Annubar (Mass Flowrate) screen.....	6-66	6-74. Local Units screen.....	6-129
6-35. Pure Gas/Air screen.....	6-68	6-75. Linearisation screen.....	6-131
6-36. Gas CV (ISO6976 or GPA2172- ASTMD3588) screen.....	6-70	6-76. Stream Sampling screen.....	6-133
		6-77. AGA8 screen.....	6-136
		6-78. Gas CV screen.....	6-139
		6-79. AGA7 screen.....	6-144
		6-8. Dual Units Setup dialog box.....	6-9
		6-80 Gas Composition screen.....	6-145
		6-81. Gas Properties screen.....	6-150

6-82. Local Units screen.....	6-152	10-1. Device Manager.....	10-2
6-83. Linearisation screen .....	6-154	10-2. Device Manager Hardware .....	10-3
6-84. Stream Sampling screen.....	6-156	10-3. Advanced Settings.....	10-4
6-85. Ultrasonic Flow Setup screen.....	6-159	10-4. Remote Front Panel.....	10-7
6-86. Ultrasonic Control screen .....	6-162	10-5. Remote Front Panel Startup Menu.....	10-8
6-87. Qsonic Flow Setup screen.....	6-164	11-1. Remote Archive Uploader screen.....	11-2
6-88. SICK Control screen.....	6-165	11-2. Display Editor with shortcut menu .....	11-3
6-89. Local Units screen.....	6-168	11-3. Edit FC List Item screen .....	11-5
6-9. Dual Units Setup – Periodic Totals dialog box .....	6-10	11-4. Tools Menu - Automatic Operation Enabled .....	11-6
6-90. Linearisation screen .....	6-169	11-5. Typical Display Page (Stream 2 Flow Limits shown).....	11-7
6-91. Sampling screen.....	6-171	11-6. Remote Archive Uploader Tree.....	11-9
6-92. Observed Density Correction screens	6-174	11-7. Progress Bar .....	11-10
6-93. Standard Density Correction screens	6-182	11-8. Manual Upload Options.....	11-11
6-94. BSW screen.....	6-189	11-9. Report Archive.....	11-12
6-95. Coriolis screen.....	6-190	11-10. Select Folder .....	11-13
6-96. Local Units screen.....	6-193	11-11. Select Folder .....	11-13
6-97. Linearisation screen .....	6-195	11-12. Save As .....	11-15
6-98. Sampling screen.....	6-197	11-13. Compact Folder Format.....	11-16
6-99. Observed Density Correction screens	6-200	11-14. Extended Folder Format.....	11-17
7-1. Conversion/Constants screen.....	7-2	11-15. Print dialog .....	11-18
7-2. Totals Descriptor screen .....	7-3	11-16. Print Preview .....	11-19
7-3. Edit Description dialog box.....	7-3	11-17. Print Setup .....	11-20
7-4. Alarms screen.....	7-4	11-18. Abort Transfer.....	11-20
7-5. Security screen.....	7-15	12-1. PCSetup Reports screen.....	12-2
7-6. Passwords dialog box.....	7-15	12-2. PCSetup Reports screen with Edit button .....	12-3
7-7. Security screen, Password Edits .....	7-17	12-3. Report Editor .....	12-3
7-8. Passwords dialog box.....	7-17	12-4. Select Config dialog.....	12-4
7-9. Data Item Security .....	7-18	12-5. Select Config dialog.....	12-4
7-10. Units Security dialog box.....	7-19	12-6. Report Editor screen (populated) .....	12-5
7-11. Units Security Level.....	7-19	12-7. Report Editor menu.....	12-6
7-12. Login dialog box.....	7-20	12-8. Placement Editor.....	12-7
7-13. Displays/Webserver screen .....	7-21	12-9. Connect Wizard .....	12-8
7-14. Calc Explorer (blank).....	7-22	12-10. Placement Editor with revised label ...	12-8
7-15. Calc Explorer menu.....	7-23	12-11. Placement Editor dialog box.....	12-9
7-16. Calc Explorer Menu Options .....	7-23	12-12. Connect Wizard.....	12-9
7-17. Connect Wizard .....	7-25	13-1. Display Editor main menu screen.....	13-2
7-18. Newly Added Item.....	7-25	13-2. Typical Display Page (Stream 2 Flow Limits shown).....	13-3
7-19. Adding Inputs .....	7-26	13-3. Display Editor with shortcut menu .....	13-4
7-20. Added Units .....	7-26	13-4. Edit dialog box .....	13-5
7-21. Adding Outputs.....	7-27	13-5. Edit dialog box .....	13-6
7-22. Added Outputs.....	7-28	13-6. Connect Wizard .....	13-6
7-23. Saving a Bitmap.....	7-29	13-7. Translate dialog box .....	13-7
8-1. System Editor screen (blank).....	8-2	13-8. Display Regenerating.....	13-9
8-2. Open dialog box .....	8-2	14-1. Modbus Editor main screen.....	14-3
8-3. Open dialog box (with .cfg file).....	8-3	14-2. Properties dialog box .....	14-4
8-4. System Editor screen (loaded).....	8-3	14-3. Insert shortcut menu.....	14-6
8-5. Object/Table Relationship .....	8-4	14-4. Enter Details dialog box.....	14-6
8-6. System Editor screen .....	8-5	14-5. Choose dialog box.....	14-7
8-7. Calc Editor dialog box.....	8-7	14-6. Enter Details dialog box.....	14-7
8-8. Connect Wizard.....	8-8	14-7. Connect Wizard .....	14-8
8-9. Edit Dialog (System Editor).....	8-9	14-8. Edit Format dialog box .....	14-9
8-10. Edit dialog box.....	8-9	14-9. Message Details dialog box .....	14-11
9-1. PCSetup Error Message .....	9-2	14-10. Connect Wizard.....	14-11
9-2. Config Transfer screen .....	9-3	14-11. Message Details dialog box (with trigger) .....	14-12
9-3. Config Transfer screen .....	9-5	14-12. Select Slaves dialog box.....	14-12
9-4. Config Transfer Send tab.....	9-7	14-13. Choose dialog box.....	14-13
9-5. Config Transfer Receive tab .....	9-8	14-14. Modbus Map Regeneration.....	14-13
9-6. Save As New Config dialog box .....	9-9	14-15. Modbus Map Options.....	14-14
9-7. Config Transfer Logging tab .....	9-9		
9-8. Config Transfer Licensing tab .....	9-10		
9-9. Licenses on Key .....	9-11		
9-10. Transferred License.....	9-12		



15-1. LogiCalc screen.....	15-2	F-12. Edit dialog (3).....	F-13
15-2. Select Config dialog box.....	15-3	F-13. Peer Critical CALCTAB Object.....	F-14
15-3. LogiCalc screen (loaded).....	15-3	F-14. Calc Editor Outputs.....	F-14
15-4. LogiCalc screen (loaded).....	15-5	F-15. Connect Wizard – Assigning an object to an output of the SYS PEER CRITICAL Calctab.....	F-15
15-5. Set Variable dialog.....	15-15	F-16. New Output with Object Assigned.....	F-15
B-1. Components of a BIDI Prover.....	B-5	F-17. Connect Wizard – Assigning an object to an input of the SYS PEER CRITICAL calctab.....	F-16
B-2. Sphere Switch Selections.....	B-6	F-18. System Editor.....	F-17
B-3. Two Sphere Switches.....	B-8	F-19. Status Input and Output Description....	F-18
B-4. Pinout for Two Sphere Switches.....	B-8	F-20. Duty/Standby Connection Diagram.....	F-19
B-5. Four Sphere Switches.....	B-9	F-21. Connecting A's Health Digital Output to B's Digital Input.....	F-20
B-6. Pinout for Four Sphere Switches.....	B-9	F-22. List of Discrete Inputs before Assignment ...	F-20
B-7. Initial Pass of Proof Run Timing.....	B-45	F-23. Digital Input Selection.....	F-21
C-1. Product Table Options.....	C-3	F-24. SYS PEER HEALTH and PEER HEALTH Object (after assignment to Digital Inputs).....	F-21
C-2. Station Batching.....	C-8	F-25. List of Discrete Outputs before Assignment .....	F-21
C-3. Flowrate Totals.....	C-14	F-26. SYS PEER DUTY IO Digital Output Assignment.....	F-22
C-4. Product Interface Detection Form (in PCSetup).....	C-16	F-27. SYS PEER HEALTH Digital Output Assignment.....	F-22
C-6. Slops Handling Examples.....	C-18	F-28. SYS PEER HEALTH Digital Output Assignment.....	F-23
C-11. Batch Configuration.....	C-39	F-29. PCSetup Communications.....	F-23
C-12. Volume Load.....	C-40	F-30. Peer Params Setup dialog.....	F-24
C-13. Batch Defined.....	C-40	F-31. Peer Duty Logic page.....	F-24
C-14. Batch Information.....	C-41	F-32. Peer Master Link Operator Command Page .....	F-25
C-15. Batch Information.....	C-42	F-33. Peer Duty Logic page.....	F-26
C-16. Ticket Number.....	C-43	I-1. Defining a Serial Printer on COM3 Port.....	I-3
C-17. Recalculate Day.....	C-43	I-2. Defining a Network Printer.....	I-3
C-18. Recalculate Base Density.....	C-44	I-3. Defining Comms Task 20 for the Printer.....	I-4
C-19. Recalculate Command.....	C-44	I-4. Redefining Printer Retries.....	I-5
C-20. Recall Ticket Number.....	C-45	I-5. Selecting the ALARM FORMAT Object.....	I-6
C-21. Day Selection.....	C-45	I-6. Edit Dialog.....	I-7
C-22. Base Density Display.....	C-46	K-1. Gas Composition – MOLE SPLITS.....	K-29
C-23. Base Density Display.....	C-46	K-2. Add Report – CHR TELEMETRY.....	K-37
C-24. Base Density Display.....	C-47	K-3. CHR TELEMETRY.....	K-37
C-25. Station Flow Switching screen.....	C-48	K-4. Example Report – CHR TELEMETRY... ..	K-38
C-26. Stream Flow Switching screen.....	C-49	K-5. CHR D/LOAD.....	K-39
C-27. Batch Stack.....	C-55	K-6. CHR D/LOAD.....	K-39
C-28. Config600 System Editor (1).....	C-58	K-7. CHR D/LOAD.....	K-40
C-29. Config600 System Editor (2).....	C-58	K-8. CHR TELEMETRY.....	K-41
C-30. Batch Slots.....	C-58	File Locations	
C-31. Slot Editing Options.....	C-59	Remote Archive Uploader.....	11-12
C-32. Insert Batch Command.....	C-59	File Menu.....	2-27
C-33. Entering Data.....	C-61	File names.....	12-5
C-34. Pressing CLEAR.....	C-61	Filter (*) Keyword.....	G-2
C-35. Input out of Range.....	C-61	Filter Keyword.....	G-2
C-36. Abort Confirmation Screen.....	C-62	Finding Objects.....	8-6
C-37. Changes Discarded Message.....	C-62	Firewall.....	G-1
C-38. Copy to Slot.....	C-63	*Filter Keyword.....	G-2
C-39. Confirmation Screen.....	C-63	ACCEPT.....	G-2
C-40. Changes Discarded.....	C-63	Adding Rules to the Chain.....	G-3
C-41. Delete Confirmation.....	C-64	After Checking the Rules.....	G-3
C-42. Batch Slots.....	C-65	ALLOW_IN.....	G-2
C-43. Slot Editing Options.....	C-65	ALLOW_OUT.....	G-2
F-1. Select Communications (Step 6 of 6).....	F-4	Applying a Rule to a Range of IPs.....	G-3
F-2. Comms Link with Peer Master Link and Port Settings.....	F-5	COMMIT.....	G-3
F-3. Port Com Setup Dialog.....	F-5		
F-4. Peer Params Setup screen.....	F-7		
F-5. Pop-up menu on Alarms screen.....	F-10		
F-6. Edit dialog (1).....	F-10		
F-7. Edit dialog (2).....	F-11		
F-8. Peer Critical Alarm.....	F-11		
F-9. CALCTAB screen.....	F-12		
F-10. Edit dialog (1).....	F-12		
F-11. Edit dialog (2).....	F-13		

Committing the Rules.....	G-3	Editing.....	5-2
Default Policies.....	G-2	Flow Switching.....	6-10, C-47
DROP.....	G-2	ISO5167.....	2-8
exfwall.txt.....	G-1	Low Limit for Sampling.....	5-15
FORWARD.....	G-2	PID Loop Control.....	6-5
INPUT.....	G-2	Setpoint for Streams.....	6-10, C-47
Inverting a Rule.....	G-3	Streams.....	6-5
Operational Behaviour.....	G-3	Units.....	3-3
OUTPUT.....	G-2	VCone.....	2-8
Rules File.....	G-1	VCone Wet Gas.....	2-8
User Defined Chains.....	G-2	Flow-Weighted Averaging (TWA).....	6-19
Fixed Vel Alarm.....	7-9	for/next.....	
Flange.....	6-89	LogiCalc Editor.....	15-24
Flash memory.....	A-3	For/next.....	15-7
FloBoss S600+.....	1-3	Format.....	2-23
Flow.....	6-59	Forward MF.....	
Flow balance.....	A-3	Ultrasonic Gas.....	6-158
Flow Balance Setup.....		Forward Premium Flow Limit.....	
Ball Prover.....	5-18	.....	6-59, 6-64, 6-66, 6-158
Flow Calibration Pressure.....	6-45	Free running.....	15-14
Coriolis.....	6-189	FREQT.....	E-8
Flow Coefficient.....	6-59, 6-64, 6-66, 6-89	Frequency.....	4-22
Flow Computer List.....	11-2	FRQ.....	A-3
Flow Data Source.....		FRQ O-Rnge Alarm.....	7-9
Coriolis.....	6-189	Function.....	4-30, 4-31
Flow Extension.....	6-80	Numioboards.....	15-12
Flow Integral Acceptance Factor.....	6-45	Numstation.....	15-12
Coriolis.....	6-189	Numstream.....	15-12
Flow Prop. 6-42, 6-132, 6-155, 6-171, 6-197, 6-216.....		Function codes.....	14-1
Flow Prop 1.....	J-3	function/end.....	
Flow Prop 2.....	J-3	LogiCalc Editor.....	15-23
Flow Prop 3.....	J-3	FWA.....	6-18
Flow Rate Points.....		CG.....	6-11
Ultrasonic Gas Spool Wall Roughness.....	6-158		
Flow switching.....	A-3		
Flow Switching.....	5-8, 6-10, C-47		
Alarms.....	C-53		
Algorithm 1.....	C-50		
Algorithm 2.....	C-50		
Algorithm 3.....	C-51		
Algorithm 4.....	C-51		
Algorithms.....	C-50		
Stages.....	C-51		
Station.....	C-47		
Stream.....	C-49		
Streams.....	6-10, C-47		
Flow Units.....			
Coriolis.....	6-189		
Flowing Conditions.....	6-68		
Flowing Viscosity.....	6-68		
Flowrate.....	5-2, 6-158		
SICK.....	6-165		
Ultrasonic.....	6-158		
Flowrate Low Limit.....	6-42, 6-132, 6-155		
Sampler Coriolis Liquid.....	6-171, 6-197, 6-216		
Flowrate/Frequency.....	6-40, 6-168		
Turbine Gas.....	6-130		
Turbine Liquid.....	6-193, 6-219		
Ultrasonic Gas.....	6-153		
Flowrates.....			
AGA3.....	2-8		
Alarm Limits.....	6-5		
Annubar.....	2-8		
		<b>G</b>	
		Gas	
		AGA3 (Volume Flowrate).....	6-80
		AGA7 (Gross Volume Flowrate).....	6-119, 6-143
		AGA8 (Compressibility) - Gas DP.....	6-56
		AGA8 (Compressibility) - Gas Turbine.....	6-112
		AGA8 (Compressibility) - Gas Ultrasonic.....	6-136
		Annubar.....	6-66
		Calorific Value (AGA5).....	6-25, 6-30
		Coriolis.....	6-22, 6-45
		AGA8.....	6-23
		Coriolis.....	6-189
		Gas Properties.....	6-36
		Downstream/Upstream Correction.....	6-50
		DP.....	6-50
		AGA3.....	6-80
		Annubar (Mass Flowrate).....	6-66
		Cell Input.....	6-95
		GPA2172.....	6-69
		ISO5167 (Mass Flowrate).....	6-59
		ISO6976.....	6-69
		ISOTR9464(Mass Flowrate).....	6-62
		NX19.....	6-77
		PTZ.....	6-78
		Pure Gas/Air (Mass Flowrate).....	6-68
		SGERG.....	6-74
		V-Cone (Mass Flowrate).....	6-64
		Ethylene.....	6-39

Gas Component Flow Weighted Averaging ...	6-11	General Guidelines	
Gas Composition - Coriolis .....	5-10, 6-31, 6-82, 6-122	System Editor .....	8-10
Gas Composition - Ultrasonic.....	6-145	General Reports	
Gas CV (ISO6976 or GPA2172).....	6-25	Adding to a configuration.....	3-10
Gas CV (ISO6976 or GPA2172) - Gas DP ...	6-69	General Settings	
Gas CV (ISO6976 or GPA2172) - Gas Turbine....	6-115	Streams.....	6-4
Gas CV (ISO6976 or GPA2172) - Gas Ultrasonic	6-139	GOST 30319.1-96 Calc 52/53.....	6-88
Gas Expansion.....	6-64	GOST 8563-97.....	6-89
Gas Expansion Factor .....	6-66	GOST CV.....	6-88
Gas Options .....	2-8	GOST Flow.....	6-89
Gas Properties - Coriolis .....	6-36	GPA .....	6-25
Gas Properties - DP .....	6-92	Ultrasonic Gas .....	6-139
GOST CV .....	6-88	GPA2172 .....	6-25, 6-69, 6-115, 6-139
GOST Flow.....	6-89	Grab Count.....	6-42, 6-132, 6-155, 6-171, 6-197, 6-216
ISO5167 (Mass Flowrate).....	6-59	Grab Size.....	4-22
ISOTR9464.....	6-62	Grab Volume .....	5-15, 6-42, 6-132, 6-155
Linearisation - Turbine .....	6-130	Sampler Coriolis Liquid .....	6-171, 6-197, 6-216
Linearisation - Ultrasonic.....	6-153	Graphical display.....	7-22
NX19 (Compressibility) .....	6-77	Gross.....	6-56
Pipe Correction.....	6-53	Gross Heating Value (HV).....	6-56, 6-112
PTZ (Compressibility) .....	6-78	Ultrasonic Gas .....	6-136
SGERG (Compressibility).....	6-74	Gross1.....	6-112, 6-136
Steam .....	6-86	Gross2.....	6-112, 6-136
Turbine.....	6-112	Group Count.....	6-42, 6-132, 6-155
AGA8.....	6-112	Groups	
Gas Properties .....	6-126	Alarms.....	7-4
GPA.....	6-115		
ISO6976.....	6-115	<b>H</b>	
Ultrasonic .....	6-135	H/W Fail Alarm.....	7-9
AGA8.....	6-136	Hardware .....	5-43
Gas CV .....	6-139	Ball Prover .....	5-30
Gas Properties .....	6-149	Compact Prover.....	5-43
Ultrasonic Flow.....	6-158	Hardware Handshake .....	F-4
Ultrasonic SICK Control .....	6-165	Master Meter Prover.....	5-56
V-Cone (Mass Flowrate).....	6-64	HART .....	A-3
Z Steam.....	6-86	Modes (MODE TAB PLANTI/O).....	E-21
Gas Chromatograph .....	5-10, 6-31, 6-82, 6-122, 6-145	HART Boards	
Gas Composition.....	6-68	Editing.....	4-23
Coriolis.....	5-10, 6-31, 6-82, 6-122	HART Module .....	2-4, E-8
Ultrasonic .....	6-145	Master Mode .....	E-20
Gas Properties		Modes (MODE TAB PLANTI/O).....	E-23
Coriolis.....	6-36	Poll Format.....	E-20
DP .....	6-92	HART Modules.....	4-22
Turbine.....	6-126	HARTTAB .....	E-10
Ultrasonic .....	6-149	Heating Value.....	6-30
Gas Stream		Help Menu.....	2-27
AGA8.....	6-56	Hex .....	A-3
Gas Composition..	5-10, 6-31, 6-82, 6-122, 6-145	Hi Alarm.....	7-9
Gas Turbine.....	6-119, 6-143	Hierarchy menu.....	2-26
Pipe Correction.....	6-53	High .....	5-2, 13-5
QSONIC.....	6-163	H 5-2, 6-5	
Gas Turbine		High Band .....	6-5
AGA7.....	6-119, 6-143	High Scale.....	4-15, 4-24
Gas Velocity .....	6-158	High High.....	5-2
QSONIC.....	6-163	HH .....	5-2, 6-5
Ultrasonic Control.....	6-162	High Prd Alarm.....	7-9
GC FWA.....	6-11	High Scale.....	4-16
General Formulae		Highway Addressable Remote Transducer (HART)	
Provers.....	B-67	.....	4-22
		Hi-Hi Alarm.....	7-9
		Hi-Hi Cell.....	6-97

Holding register.....	A-3	Illegal Alarm.....	7-9
Hot Duty Standby.....	2-16	Initial	
HV.....	A-3	Ball Prover Constants.....	5-23
Hydrometer Correction		Initial Mode.....	4-8, 5-10, 6-31, 6-82, 6-122, 6-145
Coriolis Observed Density Correction.....	6-173	Initial Stream Configurations.....	6-2
Turbine Observed Density Correction.....		Inlet Edge Radius.....	6-89
.....	6-199, 6-222	Input.....	4-1
Hz.....	A-3	INPUT	
<b>I</b>		Applying a Firewall Rule to a Range of IPs....	G-3
I/O.....	A-4	Input Parameters	
Adding a New Point.....	4-15	Ultrasonic Control.....	6-162
Assignment & Scalings.....	7-15	Inputs.....	8-7
Ball Prover Hardware.....	5-30	AGA3 (Volume Flowrate).....	6-80
Board.....	4-2, 4-6, 4-15, 4-19	Bi-directional proving.....	B-3
Channel.....	4-2, 4-6, 4-15, 4-19	Coriolis Gas Properties.....	6-36
Compact Prover Constants.....	5-43	Coriolis Standard Density Correction.....	6-182
Coriolis.....	6-189	DP Gas Properties.....	6-92
Density.....	6-45, 6-189	ISO5167 (Mass Flowrate).....	6-59
Master Meter Hardware.....	5-56	ISOTR9464.....	6-62
Meter Variable Limits.....	6-45	Turbine Gas.....	6-126
Pressure.....	6-45, 6-189	Turbine Observed Density Correction.....	
Selection.....	6-45	.....	6-199, 6-222
Temperature.....	6-45, 6-189	Turbine Standard Density Correction.....	6-207
I/O alarms.....	7-4	Ultrasonic Control.....	6-162
I/O Board.....	4-17	Ultrasonic Gas.....	6-158
I/O Channel.....	4-18, 4-20	Insert.....	14-7
I/O module.....	4-20	Insert.....	8-6
I/O Module.....	2-4	Insert Line.....	12-6
I/O Selection		Insert Page.....	13-3
Coriolis.....	6-189	Insert/Append Page.....	13-5
I/O Setup.....	2-4, 4-1	Insert Menu.....	13-3
Adding a New I/O Point.....	4-15	Display Editor.....	13-5
Analog Outputs.....	4-15	Insert Special.....	14-6
Communications Port.....	4-30	Inserting Modbus Slaves.....	14-12
Density Inputs.....	4-17	Inspection Period.....	6-89
Digital Inputs.....	4-2	Installation.....	1-5
Discrete (Digital) Outputs.....	4-5	Installing	
Discrete Inputs.....	4-2	LogiCalc on the S600+.....	15-15
HART Modules.....	4-22	Int Pipe Roughness.....	6-89
PID Loops.....	4-23	int(x)	
Pulse Outputs.....	4-21	LogiCalc Editor.....	15-27
Turbine Inputs.....	4-19	Integer.....	A-4
I/P Err Alarm.....	7-9	Integ-Fail Alarm.....	7-9
Icon bar.....	2-26	Integral Action (I).....	4-29
Icon Bar.....	2-27	Integral Time.....	4-24
System Editor.....	8-6	Interface	
Icons		QSonics.....	6-163
System Editor.....	8-6	Internal	
Ideal Calorific Value (SUP).....	6-25, 6-69, 6-115	Ultrasonic Gas.....	6-158
Ultrasonic Gas.....	6-25, 6-139	Interpolation Factor.....	5-30
Ideal Density.....	6-25, 6-69, 6-115	Ball Prover Hardware.....	5-30
Ultrasonic Gas.....	6-139	Compact Prover Constants.....	5-43
Ideal Relative Density (RD).....		Introduction.....	1-1
.....	6-25, 6-56, 6-69, 6-112, 6-115	Inuse Composition.....	6-36, 6-88, 6-92, 6-149
Ultrasonic Gas.....	6-136, 6-139	Turbine Gas.....	6-126
Identity.....	7-21	Inuse Meter Factor	
if / then / else / endif		Ultrasonic Gas.....	6-158
LogiCalc Editor.....	15-24	Invalid Inc Alarm.....	7-9
if/then.....	15-11	Invert.....	4-2, 4-5
if/then/else/endif.....	15-11	Inverting a Firewall Rule.....	G-3
IIO.....	A-4	IO Fail Alarm.....	7-9
		IOASSIGN.....	E-10

ioboard(x), station(x), stream(x)	
LogiCalc Editor.....	15-26
IP.....	A-4
IP O-Rnge Alarm.....	7-9
IP VII/2 4.12.....	6-213, 6-236
IP2.....	6-173, 6-199, 6-222, A-4
iptables.....	G-1
IS.....	A-4
Isentropic Exponent.....	6-36, 6-59, 6-64, 6-66, 6-68, 6-80, 6-89, 6-92, 6-126, 6-149
ISO.....	A-4
ISO 5167.....	A-4
ISO 6976.....	A-4
ISO5167.....	2-8, 6-59, 6-64
ISO5167 (Mass Flowrate).....	6-59
ISO6976.....	6-25, 6-69, 6-115, 6-139
ISO6976/1995.....	6-69, 6-115, 6-139
Ultrasonic Gas.....	6-139
ISOTR9464.....	6-62
Item.....	4-16, 4-22
Item Type.....	4-16
Iteration Type	
Coriolis Observed Density Correction.....	6-173
Turbine Observed Density Correction.....	6-199, 6-222
<b>J</b>	
Joule-Thompson.....	6-50
JT Coefficient.....	6-50, 6-62
JT ISOTR9464.....	2-8
JT METHOD.....	6-50
<b>K</b>	
K Factor.....	5-21
K Factors	
Compact Prover Alarm Limits.....	5-44
Linearisation.....	6-168
Local Units.....	6-192, 6-215
Turbine Liquid.....	6-193, 6-219
Units.....	7-17
K_Comp Alarm.....	7-9
Kdpf.....	6-45
Coriolis.....	6-189
Keypad.....	4-9, 6-110, 6-241
Keypad Fail with Recovery ....	5-10, 6-31, 6-82, 6-122, 6-145
Keypad Moles.....	5-10, 6-31, 6-82, 6-122, 6-145
K-factor.....	6-193
K-factors	
Turbine Gas.....	6-130
KG/M3.....	5-23, 5-36, 5-50
KPINT.....	E-10
KPINTARR.....	E-10
KPREAL.....	E-12
KPREALARR.....	E-12
KPSTRING.....	E-13
Ktpf1.....	6-45
Coriolis.....	6-189
<b>L</b>	
Language Specifications	
LogiCalc Editor.....	15-23
Last Edited.....	15-2
Lastgood.....	6-241
Launching	
Accessing the System Editor.....	8-2
Display Editor.....	13-1
LogiCalc Editor.....	15-2, 15-5
Remote Archive Uploader.....	11-1, 11-2
Remote Front Panel.....	10-7
Launching Config600.....	1-8
lb - kg.....	7-1
Leading Zeros.....	13-5
LED.....	A-4
Left pane.....	2-26
Length.....	7-1
let	
LogiCalc Editor.....	15-24
Levels	
Deleting.....	7-16
Editing.....	7-16
Security.....	7-15, 7-16, 7-21
Licensing.....	9-10
Limit Check.....	6-59, 6-62, 6-80, 6-89, 6-112
Limits.....	13-5
Coriolis Gas Composition.....	5-10, 6-31, 6-82, 6-122
Ultrasonic Gas Composition.....	6-145
Limits alarms.....	7-4
Line Pressure.....	6-149
Ultrasonic Gas.....	6-136, 6-158
Line Temperature.....	6-149
Ultrasonic Gas.....	6-136, 6-158
Linear Two-point ADC Device Calibration.....	D-3
Linear Two-point Device PRT Calibration.....	D-8
Linearisation.....	6-193
Alarms.....	6-40, 6-168, 6-219
Flowrate/Frequency.....	6-40, 6-168
Gas – Coriolis.....	6-40, 6-168
K-factor.....	6-168
Liquid – Turbine.....	6-193, 6-219
Meterfactor.....	6-40, 6-168
Turbine Gas.....	6-130
Ultrasonic Gas.....	6-153
Link Alarm.....	7-9
Link to Stream.....	4-30
Liquid	
Coriolis.....	6-189
Linearisation.....	6-193, 6-219
Liquid – Coriolis.....	6-167, 6-189
Liquid – Turbine.....	6-192
Liquid – Ultrasonic.....	6-215
Turbine	
Linearisation.....	6-193
Liquid Stream	
Sampling.....	6-171, 6-197, 6-216
Live Inputs	
Coriolis Standard Density Correction.....	6-182
Turbine Observed Density Correction.....	6-199, 6-222
Turbine Standard Density Correction.....	6-207

Live/Check Mode Selection.....	E-19	Perform PTZ Calculations and Convert Units.....	15-20
Lo Alarm.....	7-9	Perform PTZ Calculations on All Streams....	15-22
Lo Mid Hi Cell.....	6-98	pow(x, y).....	15-27
Load Config.....	15-2	PTZ Calculations.....	15-17
Local Units.....	6-192, 6-215	Remotely Debugging.....	15-16
K-FACTOR UNITS.....	6-192, 6-215	return.....	15-25
LOG.....	E-13	Section Index.....	15-25
log(x)		setalarm(x, v), clearalarm(x, v), accalarm(x, v).....	15-27
LogiCalc Editor.....	15-27	setalarm/clearalarm/accalarm.....	15-26
Logging.....	9-9	sin(x), cos(x), tan(x).....	15-27
LogiCalc.....	15-1, 15-3	Starting.....	15-5
const.....	15-8	Statements.....	15-23
Constants.....	15-8	Suppressing Alarms.....	15-28
dim.....	15-6	Temperature Units.....	15-18
for/next.....	15-7	Testing Alarms.....	15-28
Function		timenow().....	15-27
Numiboards.....	15-12	while/do/wend.....	15-24
Numstation.....	15-12	LogiCalc Tips.....	15-4
Numstream.....	15-12	Login.....	2-27, 7-19, 7-20
Loops.....	15-7	Lo-Hi Cell.....	6-96
Remote debug.....	15-16	Lo-Hi-Hi Cell.....	6-102
Statement		LoLo Alarm.....	7-9
const.....	15-9	Loop.....	15-7
if/then.....	15-11	Loop Delay.....	14-4
if/then/else/endif.....	15-11	Low.....	5-2, 13-5
Variables.....	15-6	L.....	5-2, 6-5
while/do/wend.....	15-7	LL.....	5-2, 6-5
LogiCalc Editor		Low Band.....	6-5
abs(x).....	15-27	Low Data Source.....	6-45
Accessing.....	15-2	Low DP Cut Off.....	6-110
Alarms Suppressing.....	15-28	Low Frequency Cutoff.....	4-19
Alarms Testing.....	15-28	Low Low.....	5-2
Built-in Functions.....	15-26	Low Scale.....	4-15, 4-24
call.....	15-25	Low Units.....	6-45
connect.....	15-25	Streams.....	6-5
const.....	15-24	Low Flow Alarm.....	7-9
Convert Density Units from Kgm3.....	15-19	Low Prd Alarm.....	7-9
Convert Density Units to Kgm3.....	15-18	Low Scale.....	4-16
Convert Temperature Units.....	15-18		
Creating a LogiCalc.....	15-5	<b>M</b>	
Data Index.....	15-25	m - yd.....	7-1
Data Type.....	15-25	m3 - bbl.....	7-1
Debugging.....	15-16	m3 - cf.....	7-1
dim.....	15-24	MA IP Err Alam.....	7-9
Examples.....	15-16	MA Op Fxd Alarm.....	7-9
exp(x).....	15-27	MA Op Sat Alarm.....	7-9
Field Name.....	15-25	Machine ID.....	1-9
for/next.....	15-24	Machine Name.....	3-2
function/end.....	15-23	Maintenance mode.....	6-4
if then/else/endif.....	15-24	Maintenance Mode.....	6-2, 6-4
Installing on the S600+.....	15-15	Managing Configuration Reports.....	3-13
int(x).....	15-27	Mantissa.....	A-4
ioboard(x), station(x), stream(x).....	15-26	Manual Comm Settings	
Language XE "Language Specifications:LogiCalc		Remote Archive Uploader.....	11-7
Editor" Specifications.....	15-23	Manual Position.....	4-24
let.....	15-24	Map Properties	
Load Config.....	15-2	Modbus.....	14-3
log(x).....	15-27	Maps.....	14-1
NOT(x), NOTB(x).....	15-27	Mass.....	6-189, 7-1, 7-17
numiboards(), numstations(), numstream().....	15-26	Mass Fail Mode.....	6-119, 6-143
numobjects(x).....	15-26		
Perform PTZ Calculations.....	15-17		

Mass Flowrate.....6-59, 6-64, 6-66, 6-89	Turbine Liquid..... 6-193, 6-219
Mass Flowrate	Ultrasonic Gas.....6-153
Annubar..... 6-66	Meter linearisation.....A-4
ISO5167.....6-59	Meter Location..... 6-2, 6-4
ISOTR9464.....6-62	Meter Pe
Pure Gas/Air.....6-68	Coriolis Observed Density Correction.....6-173
V-Cone.....6-64	Coriolis Standard Density Correction.....6-182
Master..... 14-1	Meter Pressure.....
Master Meter	..... 6-36, 6-50, 6-74, 6-112, 6-119, 6-143
Alarm Limits.....5-56	Turbine Gas.....6-126
Constants.....5-50	Turbine Standard Density Correction.....6-207
Hardware.....5-56	Meter Pulses
Master Meter Hardware.....5-56	Master Meter Alarm Limits..... 5-56
Prover..... 5-45, B-75	Meter Setup
Run Data.....5-46	Coriolis..... 6-189
Matching Name..... 3-2	Gas Coriolis..... 6-45
Max Acceptable Gap Between Successive Polls ...	Meter Slave Addresses..... 2-16
.....6-45	Meter Temperature.....
Coriolis..... 6-189	..... 6-36, 6-50, 6-74, 6-119, 6-143
Max Flowrate	Turbine Gas.....6-126
Coriolis..... 6-189	Turbine Standard Density Correction.....6-207
Max Flowrate Meter Variable Limits.....6-45	Meter Temperature (SEL)
Max Meter Total.....6-45	Coriolis Observed Density Correction.....6-173
Coriolis..... 6-189	Meter Variable Limits..... 6-45
Maximum	Coriolis..... 6-189
Max Time Drift.....4-30	Method.....
McCrometer.....6-64	..... 5-15, 6-18, 6-42, 6-56, 6-112, 6-132, 6-155
Measured..... 6-110, 6-241	FWA.....6-11
Measurement	Sampler Coriolis Liquid..... 6-171, 6-197, 6-216
Measurement Point.....6-50	Ultrasonic Gas.....6-136
Menu bar.....2-26	Weighted Averaging..... 6-21
Menu/Page.....13-3	Min VxWorks..... 15-2
Menu/Page Clipboard.....13-8	Minimum Interval.....5-15, 6-42, 6-132, 6-155
Message Function.....14-11	Sampler Coriolis Liquid..... 6-171, 6-197, 6-216
Message Length.....14-11	Mixture SG..... 6-25, 6-30
Message Length Mode.....14-4	Modbus
Meter CCF	Data Point, Deleting..... 14-8
Coriolis Observed Density Correction.....6-173	Data Point, Inserting..... 14-5
Turbine Standard Density Correction.....6-207	Insert message request.....14-10
Meter CPL	Map Properties..... 14-3
Coriolis Observed Density Correction.....6-173	Modbus..... 4-30, 14-1, 14-2
Turbine Standard Density Correction.....6-207	Modbus.....A-4
Meter CTL	Modbus Editor
Coriolis Observed Density Correction.....6-173	Accessing..... 14-2
Turbine Standard Density Correction.....6-207	Modbus Editor..... 14-1
Meter Density.....6-68, 6-112	Display Editor..... 13-8
Turbine Standard Density Correction.....6-207	Slave Port..... 2-16
Ultrasonic Gas.....6-158	Modbus maps..... 14-2
Meter Density (DT)	Modbus Maps
Coriolis Standard Density Correction.....6-182	Regenerating.....14-13
Meter Density (SEL)	Modbus Slave Message.....14-10
Coriolis Observed Density Correction.....6-173	Modbus Slaves
Meter factor..... 5-21, 6-193, A-4	Inserting.....14-12
Meter Factor	Modbus Timeout
Compact Prover Alarm Limits.....5-44	SICK Control.....6-165
Ultrasonic Gas.....6-158	Mode.....4-19, 5-15, 6-42, 6-132, 6-155
Meter Factor Method	Sampler Coriolis Liquid..... 6-171, 6-197, 6-216
Turbine Gas.....6-130	MODE TAB CALC.....E-22
Ultrasonic Gas.....6-153	MODE TAB DENS IP.....E-22
Ultrasonic Gas.....6-158	MODE TAB DP STACK.....E-22
Meter Factors..... 6-130, 6-153	MODE TAB PLANTI/O.....E-21, E-23
Linearisation.....6-40, 6-168	Mode Tables.....E-21
Turbine Gas.....6-130	Modem.....A-4

Modes of Operation.....	6-241	Noise.....	A-4
Modulate.....	A-4	Non-linear Three-point Curve Calibration Control Mechanism .....	D-7
Molar Mass .....	6-56, 6-112	Non-volatile memory .....	A-4
Ultrasonic Gas.....	6-136	Normal.....	4-2
Mole Additional.....	5-10, 6-31, 6-82, 6-122, 6-145	Normal Flowrate	
Mole Alarms and Limits		Turbine Liquid.....	6-193, 6-219
Mole Hi Limits.....	5-10, 6-31, 6-82, 6-122, 6-145	Normalisation.....	6-11
Mole Lo Limits.....	5-10, 6-31, 6-82, 6-122, 6-145	NOT(x), NOTB(x)	
Mole Deviation Limits... 5-10, 6-31, 6-82, 6-122, 6-145		LogiCalc Editor .....	15-27
Mole Dv Alarm.....	7-10	NTP.....	4-30
Mole Fail Alarm.....	7-10	Number of Switches.....	5-30
Mole Flag.....	6-11	Ball Prover Hardware.....	5-30
Mole Hi Alarm.....	7-10	Number of Valves.....	6-10, C-47
Mole Lo Alarm.....	7-10	Numioboards .....	15-12
Mole Order.....	5-10	numioboards(), numstations(), numstream()	
Mole Order Port....	5-10, 6-31, 6-82, 6-122, 6-145	LogiCalc Editor .....	15-26
Mole Splits .....	5-10, 6-31, 6-82, 6-122, 6-145	numobjects(x, .....	15-26
Moles at Individual Stream.....	2-8	Numstation.....	15-12
Moles from Station Chromat.....	2-8	Numstations.....	15-12
Moles from Station Only .....	2-8	Numstream.....	15-12
Moles Stream .....	2-8	NX19.....	6-77
Monel.....	6-53	NX-19.....	A-4
Monitor Alarm.....	7-10	NX19 (Compressibility).....	6-77
MOV.....	6-16, A-4		
Move Display.....	13-8	<b>O</b>	
Move Uncm Alarm.....	7-10	O/P Err Alarm .....	7-10
Moving Config600 from one PC to another.....	1-10	Object.....	A-5
MTR PRESS (SEL).....	6-173	Objects .....	8-4
MULTI .....	E-14	Observed Density (DT)	
Multiplexer.....	A-4	Coriolis Observed Density Correction.....	6-173
Murdock.....	6-59	Turbine Observed Density Correction.....	6-199, 6-222
MV Clamping.....	4-24	Observed Density Correction..	6-173, 6-199, 6-222
MV Slew Rate.....	4-24	Observed Pressure (DT)	
MX-AV/AV.....	B-40, B-74, B-104	Coriolis Observed Density Correction.....	6-173
MX-MN/AVG.....	B-40, B-74, B-103	Turbine Observed Density Correction.....	6-199, 6-222
MX-MN/MN.....	B-40, B-74, B-104	Observed Temperature (DT)	
MX-MN/MX*MN.....	B-40, B-74, B-104	Coriolis Observed Density Correction.....	6-173
MX-MN/MX+MN2.....	B-40, B-74, B-103	Turbine Observed Density Correction.....	6-199, 6-222
		Octal.....	A-5
<b>N</b>		Off-line.....	A-5
N2K		Offset PRT Calibration Control Mechanism.....	D-8
Compact Prover Constants.....	5-36	Offset PRT Device Calibration.....	D-8
Navigating		O-Flow Alarm.....	7-10
Display Editor.....	13-2	On Can Full.....	5-15, 6-42, 6-132, 6-155
Navigating PCSetup Editor .....	2-25	Sampler Coriolis Liquid .....	6-171, 6-197, 6-216
Negative Limit		On Flow Status.....	5-15, 6-42, 6-132, 6-155
Compact Prover Constants.....	5-36	Sampler Coriolis Liquid .....	6-171, 6-197, 6-216
Network printing.....	I-1	On Flowrate Limit .....	5-15, 6-42, 6-132, 6-155
Network Printing		Sampler Coriolis Liquid .....	6-171, 6-197, 6-216
Configuring printers.....	I-2, I-4, J-2	On-line.....	15-16, A-5
Editing report line length.....	I-6	Open collector.....	A-5
Supported paper sizes .....	I-2	Open Configuration.....	8-6
Supported printers.....	I-2	Button.....	2-27
New Configuration.....	2-1, 2-4	Open.....	2-27
Button .....	2-27	Open Configurations.....	2-27
Name.....	2-2	Opening	
New .....	2-27	Existing Configuration.....	2-23
New LogiCalc .....	15-5	Open O/P.....	4-5
New Placement.....	12-6		
New Window .....	2-27		
No Permit Alarm.....	7-10		



System Editor.....	8-2	Link.....	2-16
Operational Modes.....	6-241	Passing an Object from the Duty to the Standby S600+.....	F-14
Opto-isolator.....	A-5	Peer to Peer Options.....	4-30, F-4
O-Range Alarm.....	7-10	Standby.....	F-1
Orifice.....	6-53	Verifying.....	F-28
Orifice Material.....	6-53	Peer-to-peer link.....	A-5
Output.....	4-1	Peer-to-peer Link.....	4-36
Outputs.....	4-5, 8-7	Perform PTZ Calculations.....	15-17
Bi-di proving.....	B-3	Perform PTZ Calculations and Convert Units.....	15-20
Coriolis Gas Properties.....	6-36	Perform PTZ Calculations on All Streams.....	15-22
DP Gas Properties.....	6-92	Period.....	6-11
Gas Properties.....	6-149	Periodic Object Transfer.....	F-16
Turbine Gas.....	6-126	Peter Temp.....	6-112
Overflow Alarm.....	7-10	Phase Locked Loop.....	5-30, 5-43
Overrange.....	A-5	Ball Prover Hardware.....	5-30
<b>P</b>		Compact Prover Constants.....	5-43
P144		Master Meter Hardware.....	5-56
I/O Module.....	2-4	Pic Fail Alarm.....	7-11
PID Type.....	E-20	PID.....	4-23, A-5
P154.....	5-30	Control Action.....	4-27
Prover I/O Module.....	2-4	Control Method.....	4-26
Prover Type.....	E-21	Derivative Time.....	4-28
P188 HART Communication Module.....	2-4	Integral Time.....	4-28
P190 Dual Ethernet Module.....	2-4	Manual Position.....	4-28
Page Clipboard.....	13-8	MV Clamping High Limit.....	4-26
Page Toggle.....	2-27	MV Clamping Low Limit.....	4-27
Parameters		Proportional Band.....	4-28
BSW.....	6-213, 6-236	PV Channel Settings.....	4-27
Calorific Value (AGA5).....	6-25, 6-30	PV Range.....	4-28
Parity.....	9-5, F-4	Setpoint.....	4-27
Pass K-factor.....	B-68	SP Rate of Change.....	4-27
Passing an Object from the Duty to the Standby S600+.....	F-14	SP Tracking.....	4-27
Password.....	7-14	Switch Over Logic.....	4-28
Password Tables.....	E-21	PID Loops.....	4-23, 4-29
Passwords.....	7-15	Analog Outputs.....	4-15
Deleting.....	7-16	Assigning.....	4-24
Editing.....	7-16	Derivative Action (D).....	4-30
Paste.....	2-27, 8-6	Flowrate Control for Streams.....	6-5, 6-10, C-47
PC Password.....	7-15	I/O Module PID Type.....	E-20
PC Setup Link		Integral Action (I).....	4-29
Enabling.....	9-2	PID.....	E-14
PCB.....	A-5	PID Control Loops.....	4-15
PCSetup Editor		PID Controller.....	4-29
Icon Bar.....	2-27	PID Type.....	E-20
Menu Bar.....	2-27	Proportional Action (P).....	4-29
Navigating.....	2-25	Runtime.....	4-24
New Configuration.....	2-1	Type.....	E-20
Opening an Existing Configuration.....	2-23	PIP.....	E-14
Version Number.....	2-27	Pipe.....	6-53
Pd		Pipe Correction.....	6-53
Turbine Standard Density Correction.....	6-207	Pipe Material.....	6-53
Pe (DT)		Pipe Correction.....	6-53
Coriolis Observed Density Correction.....	6-173	Pipe Diameter.....	6-66
Pe.....	6-199, 6-222	Ball Prover Constants.....	5-23
Peer-to-Peer.....	2-16	Compact Prover Constants.....	5-36
Critical Data.....	F-9	Pipe Inside Diameter.....	6-238
Displays.....	F-26	Pipe Outside Diameter.....	6-238
Downloading and Verifying.....	F-28	Placement Editor.....	12-7
Duty.....	F-1	Plenum	
Functionality.....	F-1	Compact Prover Constants.....	5-36
		Poisson's Ration.....	6-238

Policies	
Firewall.....	G-2
Poll Delay.....	14-4
POP.....	E-14
Port.....	4-30, 4-32, A-5
Qsonic.....	6-163
Positive Limit	
Compact Prover Constants.....	5-36
pow(x, y)	
LogiCalc Editor.....	15-27
PR OP Fxd Alarm.....	7-11
PR OP Sat Alarm.....	7-11
PRDTOT.....	E-14
Pre Switch (Forward)	
Ball Prover Constants.....	5-23
Pre Switch (Reverse)	
Ball Prover Constants.....	5-23
Pre Warn Alarm.....	7-11
Premium Billing.....	6-59, 6-64, 6-66, 6-119, 6-143
Forward Premium Flow Limit.....	6-59, 6-64, 6-66
Premium Billing Mode.....	6-59, 6-64, 6-66, 6-119, 6-143
Reverse Premium Flow Limit.....	6-59, 6-64, 6-66
Ultrasonic Gas.....	6-158
Premium Flow Limit.....	6-119, 6-143
Pressure.....	6-45, 6-56, 6-74, 6-77, 6-78, 6-112, 6-119, 6-143, 7-1, 7-2
Ball Prover Constants.....	5-23
Compact Prover Constants.....	5-36
Coriolis.....	6-189
Master Meter Constants.....	5-50
Pressure Loss.....	6-59, 6-64, 6-66, 6-89
Pressure Units.....	7-17
Qsonic.....	6-163
Ultrasonic Gas.....	6-136, 6-158
Pressure and Density.....	6-59, 6-64, 6-66, 6-89
Primary Inputs	
Ultrasonic Gas.....	6-158
Print.....	2-27, 7-21, 8-6
Print Alarms/Events.....	7-4
Print Preview.....	2-27
Print Setup.....	2-27
Remote Archive Uploader.....	11-18
Printing Err Alarm.....	7-11
Printing, network.....	I-1
Priority	
Streams Flow Switching.....	6-10, C-47
Probe Diameter.....	6-66
Process alarms.....	7-4
Product Data Sheet	
Config600.....	1-11
S600+.....	1-11
Product Interface Detection.....	C-15
Product Selection	
Coriolis Standard Density Correction.....	6-182
Turbine Observed Density Correction.....	6-199, 6-222
Turbine Standard Density Correction.....	6-207
Product Type	
Ball Prover Constants.....	5-23
Compact Prover Constants.....	5-36
Coriolis Observed Density Correction.....	6-173
Coriolis Standard Density Correction.....	6-182
Master Meter Constants.....	5-50
Turbine Observed Density Correction.....	6-199, 6-222
Turbine Standard Density Correction.....	6-207
Program.....	A-5
Program pane.....	15-3
Programs.....	15-1
Prop Band.....	4-24
Proportional Action (P).....	4-29
Protocol.....	4-30, 4-32, A-5
Prove sequence.....	A-5
PROVED KF	
Master Meter Alarm Limits.....	5-56
Prover.....	1-4
Ball	
Run Data.....	5-21
Compact	
Hardware.....	5-43
Dual Chronometry Switch Pair.....	E-20
Prover board.....	5-43
Provers	
Abort Index.....	B-21, B-29, B-62, B-88, B-92
Alarm Limits.....	5-31, 5-44, 5-56
API Ch.4 Method 1 (default)....	B-40, B-74, B-103
Average Method.....	B-34, B-66, B-97
Averaging Calculations.....	B-34, B-67, B-97
AV-MN/AV.....	B-40, B-74, B-104
Ball.....	5-20, 5-21
Ball Prover Alarm Limits.....	5-31
Ball Prover Constants.....	5-23
Ball Prover Flow Balance Setup.....	5-18
Ball Prover Hardware.....	5-30
Bi-Directional.....	5-20, 5-21
Bi-directional (ball).....	B-2
Bi-directional Constants.....	5-23
Bi-directional Prover Alarm Limits.....	5-31
Bi-directional Prover Flow Balance Setup.....	5-18
Bi-directional Prover Hardware.....	5-30
Calculations.....	B-34
Calculated MF versus Avg of Previous History	
MFs.....	B-41
Calculated MF versus Initial Base MF.....	B-41
Calculation Index.....	B-30, B-63, B-93
Calculations.....	B-97
Calculations.....	B-66
Communications.....	B-3, B-43, B-78
Compact.....	5-32, B-42
Compact Inputs.....	B-43
Compact Outputs.....	B-43
Compact Prover Alarm Limits.....	5-44
Compact Prover Constants.....	5-36
Compact Prover Hardware.....	5-43
Compact Prover Run Data.....	5-34
Complete Sequence Stage Descriptions.....	B-14, B-48, B-81
Configuration Screens.....	5-18
Constants.....	5-23, 5-36, 5-50
Control.....	B-46, B-79
Control Stage Description.....	B-57, B-89
Control Stages.....	B-56, B-88
Correction Factor (CPLm/CPLp).....	B-70, B-99
Correction Factor (CTLm/CTLp).....	B-36
Correction Factor (CTSp/CPSp).....	B-36, B-70

Correction Factor for the Effect of Pressure on the Liquid.....	B-36, B-70, B-99	Prover Indicated Volume Flowrate (m3/h)...	B-101
Correction Factor for the Effect of Pressure on the Prover Steel.....	B-36, B-70	Prover Mass (kg).....	B-102
Correction Factor for the Effect of Temperature on the Liquid.....	B-36, B-99	Prover Master Link.....	B-3
Correction Factor for the Effect of Temperature on the Prover Steel.....	B-36, B-70	Prover Module.....	2-4
Default Prove Sequence Stages.....	B-80	Pulse gating.....	B-4
Default Sequence Stages.....	B-13, B-48	Pulse Gating.....	B-44, B-79
Final Average Data (Over Consecutive Good Runs).....	B-35, B-69, B-98	Pulse interpolation.....	B-5
Formulae		Pulse Interpolation.....	B-44, B-79
Averaging Calculations.....	B-34, B-67, B-97	Pulse Measurement.....	B-4, B-79
Correction Factor (CPLm/CPLp)...	B-70, B-99	Remote.....	B-1
Correction Factor (CTLm/CTLp)...	B-36, B-99	Remote Addresses.....	2-16
Correction Factor (CTSp/CPSp)...	B-36, B-70	Remote Streams.....	2-16
Mass Prover Calculations.....	B-72	Report.....	B-95
Stability Calculations.....	B-36, B-70, B-99	Run Average Data.....	B-34, B-97
Volume Prover Calculations.....	B-71	Run Average Data (Over Number of Passes)...	B-68
General Formulae.....	B-67	Run Average Frequency (Hz).....	B-35, B-98
Gross Standard Volume (Sm3).....	B-37, B-100	Run Control Stage Description.....	B-57, B-89
Gross Volume (m3).....	B-38, B-72	Run Control Stages.....	B-56, B-88
Hardware.....	5-30, 5-43, 5-56	Run Data.....	5-34, 5-46
Indicated Volume (m3).....	B-100	Run Stage Abort Index.....	B-29, B-62, B-92
Indicated Volume Flowrate (m3/h).....	B-101	Run Stage Calculation Index.....	B-30, B-63, B-93
Inputs.....	B-3, B-43, B-78	Screens.....	5-18
K-factor Deviation.....	B-40, B-74, B-103	Sequence Abort Index.....	B-21, B-88
Local.....	B-1	Sequence and Control.....	B-46, B-79
Mass (kg).....	B-39, B-73, B-102	Sequence Stage Descriptions... ..	B-14, B-48, B-81
Mass Flowrate (kg/h).....	B-39, B-73, B-103	Sequence Stages.....	B-13, B-48, B-80
Mass K-factor (pls/kg).....	B-39, B-73, B-103	Sphere switch interface.....	B-5
Mass Prover Calculations.....	B-72	Stability Calculations.....	B-36, B-70, B-99
Master Meter.....	5-45, B-75	Stage Abort Index.....	B-29, B-62, B-92
Master Meter Alarm Limits.....	5-56	Stage Calculation Index.....	B-30, B-63, B-93
Master Meter Constants.....	5-50	Stage Description.....	B-57, B-89
Master Meter Hardware.....	5-56	Stage Descriptions.....	B-14, B-48, B-81
Master Meter Inputs/Outputs.....	B-78	Stages.....	B-13, B-48, B-56, B-80, B-88
Master Meter Run Data.....	5-46	Standard References.....	B-34, B-67, B-97
Meter Factor.....		Statistical.....	B-41, B-75, B-104
.....	B-38, B-39, B-72, B-73, B-101, B-102	Stream Data.....	B-63, B-94
Meter Indicated Standard Volume (Sm3).....		Stream/Prover Discrepancy Checks... ..	B-36, B-99
.....	B-37, B-71, B-100	Type.....	E-21
Meter Indicated Volume (m3).. ..	B-37, B-71, B-100	Valve Command Outputs.....	B-10
Meter Indicated Volume Flowrate (m3/h)...	B-102	Valve interface.....	B-10
Meter Mass (kg).....	B-39, B-73, B-102	Valve Operating Mode.....	B-10
Meter Mass Flowrate (kg/h).....	B-103	Valve Position Inputs.....	B-10
Meter/Prover Discrepancy Checks.....	B-70	Valve Seal Detection.....	B-11
MX-AV/AV.....	B-40, B-74, B-104	Variable Rate of Change.....	B-36, B-70, B-99
MX-MN/AVG.....	B-40, B-74, B-103	Volume Flowrate (m3/h).....	B-38, B-72
MX-MN/MN.....	B-40, B-74, B-104	Volume K-factor (pls/m3).....	B-38, B-72, B-100
MX-MN/MX+MN2.....	B-40, B-74, B-103	Volume Prover Calculations.....	B-71
Options.....	2-8	Proving.....	B-1
Outputs.....	B-3, B-43, B-78	PRT.....	A-5, E-15
P154 Prover Type.....	E-21	Input Object.....	D-8, D-9
Pass Average Data (Sampled during each Pass).....	B-67	Linear Two-point Device PRT Calibration.....	D-8
.....	B-67	Modes (MODE TAB PLANT/O).....	E-21
Pass Average Flowrate.....	B-68	PRT Input Object.....	D-9
Pass Average Frequency (Hz).....	B-68	PRT/RTD Inputs.....	4-6, 4-15
Pressure Correction Factor.....	B-102	PRT/RTD.....	4-6
Prove Sequence and Control.....	B-79	PRT/RTD Input.....	4-6
Prove/Stream Data.....	B-63, B-94	PRV PCF	
Prover Gross Standard Volume (Sm3).....	B-71	Master Meter Alarm Limits.....	5-56
		PRV PULSES	
		Master Meter Alarm Limits.....	5-56
		PRV_CTL.....	E-16
		Pseudo Critical.....	6-77
		PSU.....	A-5

PSW Percent.....	6-213, 6-236	Recent Files.....	2-27
PTZ.....	6-78, A-5	REF METER DENS .....	6-213, 6-236
PTZ (Compressibility).....	6-78	REF STD DENS.....	6-213, 6-236
PTZ Calculations.....	15-17	Reference	
Pulse gating .....	B-4	Ball Prover Constants .....	5-23
Pulse Gating.....	B-44	Compact Prover Constants.....	5-36
Pulse I/O Select		Master Meter Constants .....	5-50
Master Meter Hardware.....	5-56	Reference Conditions.....	6-25, 6-68, 6-69, 6-115
PULSE I/P.....	6-189	Ultrasonic Gas .....	6-139
pulse inputs.....	4-19	Reference Temperature	
Pulse interpolation		Coriolis Observed Density Correction.....	6-173
Bi-di proving.....	B-5	Coriolis Standard Density Correction.....	6-182
Pulse Interpolation.....	B-44	Turbine Observed Density Correction.....	6-199, 6-222
Pulse measurement		.....	6-207
Bi-di proving.....	B-4	Turbine Standard Density Correction.....	6-207
Pulse Measurement		Regenerate.....	2-27, 2-29
Compact Prover Alarm Limits.....	5-44	Regenerating Displays.....	13-8
Provers.....	B-4	Regenerating Modbus Maps.....	14-13
Pulse Off.....	4-5	Register .....	14-8
Pulse On.....	4-5	Re-installing Config600.....	1-10
Pulse Width.....	4-5	Related technical information.....	1-11
Pulse Outputs.....	4-21	Relative Density (SG).....	6-74, 6-80
Assigning.....	4-22	Relative Humidity.....	6-68
Pulse Width.....	4-6	Relative IDs.....	8-6
Pure Air .....	6-68	Reload Tree Command	
Pure Gas .....	6-68	Remote Archive Uploader.....	11-8
Pure Gas Air.....	6-68	Remote Access.....	7-21
PUREGAS .....	2-8	Remote Archive Uploader.....	11-1
PV Channel.....	4-24	Accessing .....	11-2
PV Range .....	4-24	Comms Fail.....	11-17
PV Type.....	4-24	Compact Folder Format.....	11-15
Pwr Reset Alarm.....	7-11	Data Integrity .....	11-17
		Directory Settings.....	11-12
		Enabling Automatic Operation.....	11-6
		Event Logging.....	11-1
		Extended Folder Format.....	11-15
		File Locations .....	11-12
		File Names.....	11-17
		File Recovery.....	11-17
		File Size.....	11-17
		Flow Computer List.....	11-2
		Launching .....	11-1
		Manual Polling .....	11-6
		Printing .....	11-18
		Reload Tree Command .....	11-8
		Report Archive.....	11-11
		Saving Reports .....	11-14
		Setting Communication Options for Manual	
		Operation.....	11-7
		Tools > Manual Comm Settings.....	11-7
		Upload All Command .....	11-5, 11-10
		Upload New Command .....	11-5, 11-10
		Remote Debug.....	15-16
		Remote Front Panel.....	10-1
		Accessing .....	10-7
		Bits per second.....	10-2
		Changing the Communications Port on your USB	
		Communications Port.....	10-2
		Configuring PC WITH a Native Serial	
		Communications Port.....	10-3
		Configuring PC without a Native Serial	
		Communications Port.....	10-1
		Configuring the S600+ .....	10-4

Data bits.....	10-2	Retrieving config files.....	9-1
Disabling.....	10-8	Retrospective Batch Totals.....	C-29
Flow control.....	10-2	Retry Limit.....	14-4
Parity.....	10-2	return	
Restoring if Remote Communications Fail.....	10-9	LogiCalc Editor.....	15-25
Serial Communications Port.....	10-1	Reverse MF	
Startup Menu.....	10-7	Ultrasonic Gas.....	6-158
Stop bits.....	10-2	Reverse Premium Flow Limit.....	6-59, 6-64, 6-66
Remotely Debugging a LogiCalc.....	15-16	Reverse Premium Limit	
Removing Report Lines.....	12-10	Ultrasonic Gas.....	6-158
Rename		Revert to Last Good after Failure.....	
Config Organiser.....	2-30	.....	5-10, 6-31, 6-82, 6-122, 6-145
REP00 – REP39.....	E-17	Reynolds Number.....	6-59, 6-64, 6-66, 6-89
Report Archive.....	11-11	Ultrasonic Gas.....	6-158
Report Editor.....	12-1	Right pane.....	2-26
Accessing.....	12-2	ROC.....	4-9, 5-23, 5-36
Copy.....	12-6	ROC PRS Units.....	7-17
Cut.....	12-6	ROC Temp Units.....	7-17
Delete.....	12-6	ROC Alarm.....	7-11
Delete Line.....	12-6	Rod Coefficient	
Edit Placement.....	12-6, 12-9	Compact Prover Constants.....	5-36
Editing a Data Point.....	12-9	ROM.....	A-5
Insert Line.....	12-6	ROM Fail Alarm.....	7-11
New Placement.....	12-6	Rounding	
Paste.....	12-6	Ball Prover Constants.....	5-23
Using.....	12-6	Compact Prover Constants.....	5-36
Report files.....	12-5	Coriolis Observed Density Correction.....	6-173
Report History		Coriolis Standard Density Correction.....	6-182
Firewall Rules to the Chain.....	G-3	Master Meter Constants.....	5-50
Report Line Length		Turbine Observed Density Correction.....	
Editing.....	I-6	.....	6-199, 6-222
Report Lines		Turbine Standard Density Correction.....	6-207
Adding.....	12-9	RS-232.....	A-5
Deleting.....	12-10	RS-422.....	A-5
Reporting		RS-485.....	A-6
CFX.....	H-1	RSMT Dish Calib Factor.....	6-59, 6-89
Reports.....	3-13, 7-21	RT Int Alarm.....	7-11
Adding.....	3-13	RTD.....	A-6
Adding a Base Time Report to a Configuration.....		RTRIP K FACTOR	
.....	3-11	Ball Prover Alarm Limits.....	5-31
Base Time.....	3-8	RTRIP M.FACTOR	
Batch Hourly.....	3-8	Ball Prover Alarm Limits.....	5-31
Company Information.....	3-2	RTRIP PULSES	
Daily.....	3-8	Ball Prover Alarm Limits.....	5-31
Deleting.....	3-13	RTS.....	A-6
Editing.....	3-13	RTS Off Delay.....	F-4
Hourly.....	3-8	RTS On Delay.....	F-4
Managing Configuration.....	3-13	RTU.....	A-6
Monthly.....	3-8	RTV.....	A-6
Multi Day.....	3-8	Run.....	15-14
Part Hour.....	3-8	Run Control Stage Description.....	B-24
Printing Remote Archive Uploader.....	11-18	Run Data	
Provers.....	B-95	Ball Prover.....	5-21
Remote Archive Uploader Report Archive.....	11-11	Compact Prover.....	5-34
Remote Archive Uploader Saving.....	11-14	Master Meter Prover.....	5-46
Saving Remote Archive Uploader.....	11-14	Run Stage Abort Index.....	B-62
System Setup.....	3-6	Runtime.....	4-24
Weekly.....	3-8	RX Buffer Size.....	14-4
Reports & Totalisation.....	7-15	RX Fail Alarm.....	7-11
Required		RX/RXD.....	A-6
Required Level.....	7-15		
Required Level.....	7-15		
Reset.....	4-19		

**S**

S.G. .... 5-23, 5-36, 5-50

S600 Connection..... 9-5

S600+..... A-6

    CFX..... H-1

    Chromatographs..... K-1

    Connecting via Serial Cable..... 9-2

    Database..... 8-3

    Database Fields..... E-2

    Database Objects..... E-2

    Firewall..... G-1

    Installing a LogiCalc ..... 15-15

    Network printing..... I-1

    Password..... 7-15

S600+ Database ..... 8-3

    Objects..... 8-4

    Tables..... 8-5

Sample..... A-6

Sampler

    ID ..... 5-15, 6-42, 6-132, 6-155

Sampler Alarm..... 7-11

Sampler ID

    Coriolis Liquid..... 6-171, 6-197, 6-216

Sampling..... 2-8, 6-171, 6-197, 6-216

    Gas Coriolis ..... 6-42, 6-132, 6-155

    Inputs..... J-1

    Liquid Coriolis..... 6-171, 6-197, 6-216

    Station..... 5-15

Save..... 15-13

Saving

    Save..... 2-27

    Save As..... 2-27

    Save as Bitmap ..... 7-29

    Save Configuration..... 2-27, 8-6

Saving a configuration..... 2-29

Saving Display Editor changes ..... 13-8

Scaling Alarm ..... 7-11, 7-12

Scope of Manual..... 1-2

Seal Fail Alarm ..... 7-12

Sec OP Fxd Alarm..... 7-12

Sec OP Sat Alarm ..... 7-12

Secondary Link..... 4-30, 4-34

Secondary Units Setup..... 5-6

    Stream ..... 6-7

Section Index..... 15-25

Security ..... 2-27, 7-14

    Checksum..... 7-20

    Data Item..... 7-17

    Deleting Passwords..... 7-16

    Display Editor..... 13-5

    Edit Button..... 2-27

    Editing..... 7-15

    Editing Passwords..... 7-16

    Level..... 7-15, 7-21

    Security Button..... 2-27

    Security for Data editing..... 7-15

SECURITY..... E-17

Security code..... A-6

See Observed Density Correction for product selection..... 6-182, 6-207

SEL PRESS

    Coriolis Standard Density Correction..... 6-182

SEL TEMP

    Coriolis Standard Density Correction..... 6-182

SEL TO BASE..... 6-173

Select Alarm..... 7-12

Selecting

    Communications ..... 2-16

Self Calib Alarm ..... 7-12

Send

    Send Configuration..... 9-6

Sens Fail Alarm..... 7-12

Sense..... 4-2, 4-3, 4-5

Sensor..... 4-23

SERG GOST 30319-96..... 6-92

Serial

    Cable ..... 9-2

    Coriolis ..... 6-189

    Density ..... 6-45, 6-189

    Meter Variable Limits ..... 6-45

    Pressure..... 6-45, 6-189

    Temperature..... 6-45, 6-189

Server Address ..... 4-30, 4-33

Set up Peer-to-Peer

    Options..... F-4

setalarm(x, v), clearalarm(x, v), accalam(x, v)..... 15-27

setalarm/clearalarm/accalarm

    LogiCalc Editor ..... 15-26

Setpoint ..... 4-9

Setpoint (SP) ..... 4-24

    Flowrate for Streams..... 6-10, C-47

    SP Clamp Rate..... 4-24

    SP Tracking..... 4-24

Settings..... 2-27, 6-110

Settle..... 6-16

Setup

    Ball Prover Constants ..... 5-23

    Compact Prover Constants..... 5-36

    Master Meter Constants ..... 5-50

    Qsonic..... 6-163

    Slave Port..... 4-30

SG ..... A-6

SG/RD..... 6-77

SGERG..... 6-74

SGERG (Compressibility) ..... 6-74

SICK Control..... 6-165

    Alarm Limits ..... 6-165

    Billing Modes ..... 6-165

    Forward Meter Factors ..... 6-165

    Forward/Reverse Premium Limits ..... 6-165

    Input Parameters..... 6-165

    Low flow cut off limit..... 6-165

    Meter Factor Method..... 6-165

    Modbus Timeout ..... 6-165

    Reverse Meter Factors ..... 6-165

    SICK COMMS ..... 6-165

Simulation ..... 15-14

sin(x), cos(x), tan(x)

    LogiCalc Editor ..... 15-27

Single..... 4-19, 6-110, 6-171, 6-197, 6-216

Single Can / Dual Can Mode ..... J-3

Single Cell..... 6-95

Single step ..... 15-14

Site Code..... 1-9

Slave.....	14-1, 14-12	Startup Menu	
Slave Address .....	4-30	Remote Front Panel.....	10-7
Slave Link.....	4-30	Startup Mode.....	6-110
Slave address.....	14-12	Startup Screen.....	2-27
Slave Address .....	14-13	Statement	
Slops Handling Examples .....	C-18	const.....	15-9
Slug Flow Alarm.....	7-12	dim.....	15-6
SOLENOID .....	6-16	if/then.....	15-11
Special Edit.....	8-7	if/then/else/endif.....	15-11
Specific heat ratio.....	6-126	Statements	
Specify I/O .....	2-4	LogiCalc Editor .....	15-23
Specifying		Station	
Communications.....	2-16	Batching .....	C-8
Streams.....	2-8	Secondary Units Setup.....	5-6
Speed		Station or stream based.....	J-1
Speed of Sound.....	6-36, 6-92, 6-126, 6-149	Station-based proving .....	B-1
Speed Alarm.....	7-12	Stations.....	5-1
Sphere switch interface.....	B-5	Alarm Limits .....	5-2
Split.....	2-27	Averaging.....	5-4
Splits.....	5-10, 6-31, 6-82, 6-122, 6-145	Configuration.....	5-1
Splits Alarm.....	7-12	Flow Switching.....	5-8, C-47
SRAM.....	A-6	Number.....	6-31, 6-82, 6-122, 6-145
Stability Bands		Pressure.....	5-4
Ball Prover Constants .....	5-23	Sampling.....	5-15
Compact Prover Constants.....	5-36	Temperature.....	5-4
Master Meter Constants .....	5-50	Totals Descriptors .....	7-3
Stability R.O.C.		Statiscal.....	B-75, B-104
Ball Prover Constants .....	5-23	Statistical.....	B-41
Compact Prover Constants.....	5-36	Status pane.....	15-4
Master Meter Constants .....	5-50	Status Pane.....	15-2
Stack Type.....	6-110	Status/Control.....	6-56, 6-74, 6-77, 6-112
Stages		Ultrasonic Gas .....	6-136
Close a Stream.....	C-51	Steam.....	6-86
Close the Last Stream .....	C-51	Calc Method Type .....	6-86
Delay after Closing.....	C-51	Calculation Limits.....	6-86
Delay after Opening.....	C-51	Enthalpy (H).....	6-86
Emergency Shutdown.....	C-51	Inputs.....	6-86
Flow Switching.....	C-51	Meter Density .....	6-86
Idle .....	C-51	Upstream Pressure.....	6-86
Monitor Flow .....	C-51	Upstream Temperature .....	6-86
Normal Shutdown.....	C-51	Stop Bits .....	9-5, F-4
Open a Subsequent Stream.....	C-51	Stopped Alarm.....	7-12
Open the First Stream.....	C-51	Stopping a Batch.....	C-40
Run Control Stage Description.....	B-24	Stream	
Stainless.....	6-53	Secondary Units Setup.....	6-7
Standard.....	6-56, 6-112, 6-119, 6-143	Stream Flow Switching Setup .....	C-49
Conditions.....	6-78, 6-80	Streams .....	5-10, 6-31, 6-82, 6-122, 6-145
Density Correction.....	6-182, 6-207	Alarm Limits .....	6-5
Ultrasonic Gas.....	6-136	Alarms to Suppress on Cutoff.....	6-5
Standard Compressibility (Zs).....	6-25, 6-56, 6-69, 6-74, 6-77, 6-78, 6-112, 6-115, 6-119, 6-143	Block Valves.....	6-16
Ultrasonic Gas.....	6-136, 6-139	Common Settings.....	6-4
Standard Density Correction		Configuration.....	6-2
Ultrasonic .....	6-230	Defining .....	2-8
Standby .....	F-1	Densitometer.....	2-8
Start Address.....	14-11	Density.....	6-119, 6-143
Starting		Details .....	6-4
Display Editor.....	13-1	Flow Switching.....	6-10, C-47
LogiCalc Editor.....	15-2, 15-5	Flowrates.....	6-5
Remote Archive Uploader.....	11-1, 11-2	Gas Component Flow Weighted Averaging ..	6-11
Remote Front Panel .....	10-7	General Settings .....	6-4
Starting a Batch .....	C-39	Initial Configurations .....	6-2
		Remote Prover.....	2-16
		Stream/Station.....	7-3

Totals Descriptors ..... 7-3  
 Type ..... 6-2, 6-4  
 Superior Calorific Value ..... 6-74  
 Supported Units ..... 3-5  
 Suppress Alarms in Maintenance ..... 6-2, 6-4  
 Sutherland Constant ..... 6-36, 6-68, 6-92, 6-126  
 Switching Points ..... 6-110  
 SYSOBJ ..... E-17  
 System alarms ..... 7-4  
 System display ..... 7-22  
 System Editor  
   Accessing ..... 8-2  
   Buttons ..... 8-6  
   Edit Dialog ..... 8-8  
   Finding Objects ..... 8-6  
   General Guidelines ..... 8-10  
   Icon Bar ..... 8-6  
   Navigating ..... 8-5  
   Objects ..... 8-4  
   System Editor ..... 8-1  
   Tables ..... 8-5  
 System Graphic ..... 2-17  
 System Host Alarms ..... 7-4  
 System Setup ..... 3-1  
   Reports ..... 3-6  
   Totalisations ..... 3-14  
   Units ..... 3-3  
   Versions ..... 3-2

**T**

Tables

1-1. Config600 Tools ..... 1-4  
 1-2. Additional Technical Information ..... 1-11  
 2-1. Config600 Icon Bar ..... 2-27  
 2-2. Config 600 Menu Bar ..... 2-27  
 3-1. Standard Measurement Units ..... 3-5  
 6-1. Observed Density Correction Product Selection ..... 6-179  
 6-2. Standard Density Correction Product Selection ..... 6-187  
 6-3. Observed Density Correction Product Selection ..... 6-205  
 6-4. Standard Density Correction Product Selection ..... 6-212  
 6-5. Observed Density Correction Product Selection ..... 6-228  
 6-6. Standard Density Correction Product Selection ..... 6-235  
 B-1. Bi-Directional Sphere Switch Selections (Prover mode set to BIDI 4-WAY and the number of switches set to 2) ..... B-6  
 B-2. Bi-Directional Sphere Switch Selections (Prover mode set to BIDI 4-WAY and the number of switches set to 4) ..... B-7  
 B-3. Type 2 ( Prover mode set to UNI TYPE 2) ..... B-7  
 B-4. Rotork (Prover mode set to UNI ROTORK and the number of switches set to 4) ..... B-7  
 B-5. Valve Positions ..... B-10  
 B-6. Default Prove Sequence Stages ..... B-13  
 B-7. Prove Sequence Stages (Complete) ..... B-14  
 B-8. Prove Sequence Abort Index ..... B-22

B-9. BIDI Prover Run Control Stages ..... B-22  
 B-10. Prover Run Control Stages ..... B-24  
 B-11. Run Stage Abort Index ..... B-29  
 B-12. Run Stage Calculation Index ..... B-30  
 B-13. Proof Run Signals ..... B-45  
 B-14. Default Prove Sequence Stages ..... B-48  
 B-15. Complete Prove Sequence Stages ..... B-48  
 B-16. Prove Sequence Abort Index ..... B-55  
 B-17. Prover Run Control Stages ..... B-56  
 B-18. Compact Run Control Stages ..... B-57  
 B-19. Run Stage Abort Index ..... B-62  
 B-20. Run Stage Calculation Index ..... B-63  
 B-21. Master Meter/Stream Combinations – Liquid ..... B-77  
 B-22. Master Meter/Stream Combinations – Gas ..... B-77  
 B-23. Default Prove Sequence Stages ..... B-81  
 B-24. Complete Prove Sequence Stages ..... B-81  
 B-25. Prove Sequence Abort Index ..... B-88  
 B-26. Prover Run Control Stages ..... B-89  
 B-27. Prover Run Control Stages ..... B-89  
 B-28. Run Stage Abort Index ..... B-92  
 B-29. Run Stage Calculation Index ..... B-93  
 C-1. Station Batch Sequence Stages ..... C-20  
 C-2. Station Batch Sequence Stages ..... C-21  
 C-3. Standalone Station Batch Sequence Stages ..... C-26  
 C-4. Supervised Station Batch Sequence Stages ..... C-27  
 C-5. Standalone Stream Batch Sequence Stages ..... C-28  
 C-6. Supervised Stream Batch Sequence Stages ..... C-29  
 C-7. BATCH CONTROL and RECALL TICKET Displays ..... C-32  
 C-8. BCH CURR BASE DENS and RECALL BASE DENS Displays ..... C-33  
 C-9. STATION BCH CURR BS&W and RECALL BS&W Displays ..... C-33  
 C-10. STATION BCH CURR MTR TEMP and RECALL METER TEMP Displays ..... C-33  
 C-11. BCH CURR RECALC and RECALL RECALC Displays ..... C-34  
 C-12. STATION/STREAM BATCH CURR RESULTS and RECALL RESULTS Displays ..... C-34  
 F-1. System Alarms Not Invoking a Failover ..... F-17  
 F-2. Status Input and Output Descriptions ..... F-18  
 FWA ..... 6-11  
 I-1. Field Descriptions ..... I-7  
 J-1. Sampling Sequence Stages ..... J-5  
 J-2. Sampling Alarms ..... J-10  
 J-3. Sampling Displays ..... J-11  
 K-1. Component Code ..... K-24  
 K-1. Station/Stream Combinations ..... K-3  
 K-2. Euro Stages ..... K-12  
 K-3. USA Stages ..... K-17  
 K-4. Siemens Stages ..... K-20  
 K-5. Generic Stages ..... K-22  
 S600+ Database ..... 8-5  
 Turbine Meter Setup ..... E-21  
 Tap Type ..... 6-59, 6-89  
 Tas Oflow Alarm ..... 7-13



Task.....	A-6	Totals Descriptors	
TASK.....	E-17	Editing.....	7-3
Task Err		TOTTAB.....	E-17
Scaling.....	7-12	TPU Fail Alarm.....	7-13
Task Err Alarm.....	7-12	Transducer.....	A-6
Task Fail Alarm.....	7-12	Transducer Modes (MODE TAB DENS IP)....	E-22
Tasks.....	4-30	Transfer.....	2-27, 9-4
TCP/IP.....	14-1, A-6	Transfers	
Technical Support.....	1-9	Logging.....	9-9
Temp Fail Alarm.....	7-12	Translate.....	13-3, 13-7
Temperature.....	6-45, 6-56, 6-68, 6-74, 6-77, 6-78, 6-112, 6-119, 6-143, 7-1	Travel.....	6-16
Ball Prover Constants.....	5-23	TRI-REG.....	A-6
Compact Prover Constants.....	5-36	Troubleshooting	
Coriolis.....	6-189	Alarms.....	7-3
Downstream/Upstream Correction.....	6-50	Checksum.....	7-20
Expansion Constant.....	6-50	Restoring the Remote Front Panel if Remote Communications Fail.....	10-9
Master Meter Constants.....	5-50	Truth Tables.....	E-21
Qsonic.....	6-163	Tsk Err Alarm.....	7-13
Security Units.....	7-17	Tube Coefficient	
Ultrasonic Gas.....	6-136, 6-158	Ball Prover Constants.....	5-23
Temperature Coefficient.....	6-238	Compact Prover Constants.....	5-36
Test.....	6-16	Turbine.....	2-8, 6-112
Text.....	13-5	Linearisation.....	6-193, 6-219
TFWA.....	7-15	Liquid.....	6-192
Thermal Expansion.....	6-64	Observed Density Correction.....	6-199, 6-222
Thermal Expansion Factor.....	6-66	Standard Density Correction.....	6-207
Thresholds.....	4-19	Turbine Inputs.....	4-19
Ticket		Assigning.....	4-19
Batching.....	C-30	Editing.....	4-21
Tile.....	2-27	Turbine Meter Setup Tables.....	E-21
Time.....	3-16	TWA.....	6-18
Time Prop.....	6-42, 6-132, 6-155	Twin Can Changeover.....	J-3
Time-out.....	6-110	Twin can changeover mode.....	5-15, 6-42, 6-132, 6-155, 6-171, 6-197, 6-216
Time & Flow Weighted Averaging.....	6-18	Two Point Control Mechanism.....	D-5
Method.....	6-18	TW-XFLOW	
Time-Weighted Averaging – XFLOW (TW- XFLOW).....	6-21	Time-Weighted Averaging – XFLOW.....	6-21
Variables.....	6-18	TX.....	A-6
Time and flow averaging.....	A-6	TX Buffer Size.....	14-4
Time and Flow Weighted Averaging.....	6-18	Tx Config Alarm.....	7-13
Time Prop.....	J-3	Tx Elec Alarm.....	7-13
timenow()		Tx Fail Alarm.....	7-13
LogiCalc Editor.....	15-27	Type.....	4-7, 6-74
Timeout.....	14-5	Coriolis Gas Composition.....	5-10, 6-31, 6-82, 6-122
Time-Weighted Averaging – XFLOW (TW- XFLOW).....	6-21	Ultrasonic Gas Composition.....	6-145
Time-Weighted Averaging (TWA).....	6-20	<b>U</b>	
Tips, LogiCalc.....	15-4	Ultrasonic	
tone - US ton.....	7-1	Gas Composition.....	6-145
Tool Bar Status Bar.....	2-27	Ultrasonic.....	2-8, 6-135
Tools Menu.....	2-27	Ultrasonic.....	6-158
Tot Corr Alarm.....	7-12	Ultrasonic	
Tot Part Alarm.....	7-12	Flow Setup.....	6-158
Tot Res Alarm.....	7-12	Ultrasonic	
Tot Roll Ovr Alarm.....	7-13	Communications.....	6-162
Tot Roll Udr Alarm.....	7-13	Ultrasonic	
Totalisation.....	3-14, E-19	Control.....	6-162
Totalise.....	A-6	Ultrasonic	
Totals.....	7-17	SICK Control.....	6-165
Totals & Flowrates.....	3-3, 7-17		
Totals & Flowrates			
Units.....	3-3		

Ultrasonic		Ultrasonic Gas .....	6-153
Liquid .....	6-215	Valve interface .....	B-10
Unassigned .....	4-6, 4-15	Valve Seal Detection .....	B-11
Unavail Alarm .....	7-13	Valves .....	2-8
Uncorrected Volume .....	7-17	Number per Stream .....	6-10, C-47
Uncorrected Volume Flowrate		Valve Setup .....	6-16
Ultrasonic Gas .....	6-158	Valve Timings .....	6-16
Undefined Alarm .....	7-13	Variable .....	15-15
Underrange .....	A-6	Variable pane .....	15-3
Understanding the CFX file structure .....	H-8	Variables .....	6-149, 15-6, A-6
Uni-Directional .....	B-23	Coriolis Gas Properties .....	6-36
Units .....	4-15, 7-17	DP Gas Properties .....	6-92
Configuration		LogiCalc Editor .....	15-2
Measurement .....	2-3	Turbine Gas .....	6-126
Local Units .....	6-192, 6-215	Variable Pane .....	15-2
System Setup .....	3-3	Weighted Averaging .....	6-21
Unlock application .....	1-9	VCF Calculations .....	5-50
Update Interval .....	4-30	V-Cone .....	A-7
Updates		V-Cone (Mass Flowrate) .....	6-64
Configuration files .....	1-1	V-CONE 2001 .....	6-64
Upload All Command .....	11-5, 11-10	VDI/VDE 2040 .....	6-77
Upload All Reports .....	11-10	Velocity	
Upload New Command		Ultrasonic Gas .....	6-158
Remote Archive Uploader .....	11-5, 11-10	Velocity Correction Factor	
Upload New Reports .....	11-10	Ultrasonic Gas .....	6-158
Upstream Compressibility (Zf) .....		Velocity of Approach Factor .....	6-59, 6-80, 6-89
6-56, 6-68, 6-74, 6-77, 6-78, 6-112, 6-119, 6-143		Velocity of sound .....	6-163
Ultrasonic Gas .....	6-136	Velocity of Sound	
Upstream Conditions .....	6-78	Qsonic .....	6-163
Upstream Correction .....	6-50	Ultrasonic Control .....	6-162
Upstream Density .....		Velocity Units .....	7-17
..... 6-56, 6-59, 6-64, 6-66, 6-77, 6-78, 6-80, 6-89		Vent Tube .....	6-59
Ultrasonic Gas .....	6-136	Verifying	
Upstream Pressure .....	6-56, 6-59, 6-62,	Peer to Peer Link .....	F-28
6-64, 6-66, 6-68, 6-77, 6-78, 6-80, 6-89, 6-92		Version	
Upstream Temperature .....	6-53,	Configuration .....	2-23
6-56, 6-62, 6-66, 6-68, 6-77, 6-78, 6-80, 6-92		System Setup .....	3-2
U-Range Alarm .....	7-13	Version Number .....	2-27
Use enhanced error check .....	6-110	View menu .....	2-27
User .....	6-53	Viewing	
User Expansion Coefficient .....	6-53	Configuration .....	2-17
User Moles .....	5-10, 6-31, 6-82, 6-122, 6-145	Viewing Batch Information .....	C-41
Username .....	7-14, 7-15	Viscosity.. 6-36, 6-59, 6-64, 6-66, 6-80, 6-89, 6-92,	
Using		6-126, 6-149	
Report Editor .....	12-6	Base Viscosity .....	6-68
Using Report Editor .....	12-6	Sutherland Constant .....	6-68
UVOL		Viscosity @ Tn .....	6-36, 6-92, 6-126, 6-149
Ball Prover Constants .....	5-23	Viscosity Calc .....	6-68
Compact Prover Constants .....	5-36	Viscosity Calc Type .....	6-36, 6-92, 6-126, 6-149
Master Meter Constants .....	5-50	Viscosity Tn .....	6-36, 6-92, 6-126, 6-149
UVOL Fail Mode .....	6-119, 6-143	VNIC .....	6-56, 6-112, 6-136
UVOL Flowrate .....	6-80	Volatile .....	A-7
<b>V</b>		Volumes .....	5-15, 6-42, 6-132, 6-155, 7-1
Validation Logic		Sampler Coriolis Liquid .....	6-171, 6-197, 6-216
Coriolis .....	6-48	Sampling .....	5-15
Validation Parameters .....	6-45	VOS (Velocity of Sound) .. 6-36, 6-92, 6-126, 6-149	
Coriolis .....	6-189	VWI .....	A-7
Value		<b>W</b>	
LogiCalc Editor .....	15-2	Wall Thick	
Turbine Gas .....	6-130	Ball Prover Constants .....	5-23
Turbine Liquid .....	6-193, 6-219	Compact Prover Constants .....	5-36

Warm St Alarm .....	7-13
Warm start .....	A-7
Warn Ch_B Alarm .....	7-13
Warn Ch_C Alarm .....	7-13
Warn Ch_D Alarm .....	7-13
Warning Alarm.....	7-13
Watchdog.....	A-7
Water (kg/m3).....	7-1
Webserver.....	3-2, 7-20
Weighted Averaging Screen.....	6-21
Welcome to Config600 screen.....	2-1
Wet Gas .....	6-59
while/do/wend	
LogiCalc Editor.....	15-24
While/do/wend .....	15-7
Windows Menu .....	2-27
Wizard	
Connect Wizard.....	7-24

**Y**

Youngs Modulus.....	6-238
Ultrasonic Gas.....	6-158

**Z**

Z AGA8.....	2-8
Z Ethylene.....	6-39
Z NX19.....	2-8
Z SGERG.....	2-8
Z Steam.....	6-86
Zb.....	6-74
Zero Div Alarm.....	7-14
Zero High Alarm.....	7-14
Zero Low Alarm.....	7-14
Zero Noise Alarm.....	7-14
Zero Op Alarm .....	7-14
Zero Prog Alarm.....	7-14

For customer service and technical support, visit [Emerson.com/SupportNet](https://emerson.com/SupportNet).

**Global Headquarters,**

**North America, and Latin America:**

Emerson Automation Solutions  
Energy and Transportation Solutions  
6005 Rogerdale Road  
Houston, TX 77072 U.S.A.  
T +1 281 879 2699 | F +1 281 988 4445  
[Emerson.com/EnergyandTransportation](https://emerson.com/EnergyandTransportation)

**United Kingdom:**

Emerson Process Management Limited  
Regulatory Compliance Department  
Company No. 00671801  
Meridian East  
Leicester LE19 1UX UK  
T +44 11 6828 23 64  
[ukproductcompliance@emerson.com](mailto:ukproductcompliance@emerson.com)

**Europe:**

Emerson S.R.L  
Regulatory Compliance Shared Services  
Department  
Company No. J12/88/2006  
Emerson 4 Street  
Parcul Industrial Tetarom 11  
Romania  
T +40 374 132 000

**Middle East/Africa:**

Emerson Automation Solutions  
Energy and Transportation Solutions  
Emerson FZE  
P.O. Box 17033  
Jebel Ali Free Zone – South 2  
Dubai U.A.E.  
T +971 4 8118100 | F +971 4 8865465

**Asia-Pacific:**

Emerson Automation Solutions  
Energy and Transportation Solutions  
1 Pandan Crescent  
Singapore 128461  
T +65 6777 8211 | F +65 6777 0947

© 2004–2023 Energy and Transportation Solutions, an affiliate of Emerson Electric Co. All rights reserved.

This publication is for informational purposes only. While every effort has been made to ensure accuracy, this publication shall not be read to include any warranty or guarantee, express or implied, including as regards the products or services described or their use or applicability. Energy and Transportation Solutions (ETS) reserves the right to modify or improve the designs or specifications of its products at any time without notice. All sales are governed by ETS terms and conditions which are available upon request. ETS accepts no responsibility for proper selection, use or maintenance of any product, which remains solely with the purchaser and/or end-user. Emerson Automation Solutions, Emerson, and the Emerson logo are trademarks and service marks of Emerson Electric Co. All other marks are the property of their respective owners.