

# Micro Motion™ 4200 2-Wire Transmitter



The Micro Motion 4200 2-wire transmitter enables the use of reliable and accurate Micro Motion Coriolis meters virtually anywhere in your plant. The 2-wire Coriolis meter delivers measurement accuracy, repeatability, and operational savings on a level not previously possible in loop-powered applications.

- Replace existing 2-wire flow devices with minimal effort and without incurring additional power or cabling costs
- Wireless THUM™ option maximizes installation and operation flexibility
- Low energy, loop-powered design enables easy integration of Coriolis into existing processes for improved measurement and reduced maintenance for an even greater number of flow points
- Reduce the complexity and improve the performance of new process plants with loop-powered mA output and HART® protocol 2-wire Coriolis
- Compact, integral 2-wire transmitter design saves electrical cost and space for use on integrated systems and skids
- Direct mass measurement improves process control while reducing number of measurement devices required
- Accurate, repeatable measurement ensures higher quality production and overall improved process profitability
- Certified for SIL2 and SIL3 Safety applications per IEC 61508

## Overview 4200 2-wire transmitter

The Micro Motion 2-wire Coriolis meter delivers multivariable and diagnostic information through HART® communications. Comprised of a cutting-edge 4200 transmitter and the proven best-in-class performance of a Micro Motion Coriolis meter, the Micro Motion 2-wire meter brings reduced costs through improved process consistency and maximized up time. Micro Motion 2-wire Coriolis is ideally suited for use in the chemical, petrochemical and refining industries, and for continuous process and mass balance applications.

### Access information when you need it with asset tags

Newly shipped devices include a unique QR code asset tag that enables you to access serialized information directly from the device. With this capability, you can:

- Access device drawings, diagrams, technical documentation, and troubleshooting information in your MyEmerson account
- Improve mean time to repair and maintain efficiency
- Ensure confidence that you have located the correct device
- Eliminate the time-consuming process of locating and transcribing nameplates to view asset information

## Installation types for the 4200 transmitter



### WARNING

If you are installing the transmitter in a hazardous area, refer to Micro Motion approval instructions, shipped with the product or available from the Emerson web site ( [Emerson.com/flowmeasurement](https://www.emerson.com/flowmeasurement)). Improper installation in a hazardous area can cause an explosion.

**General configuration**

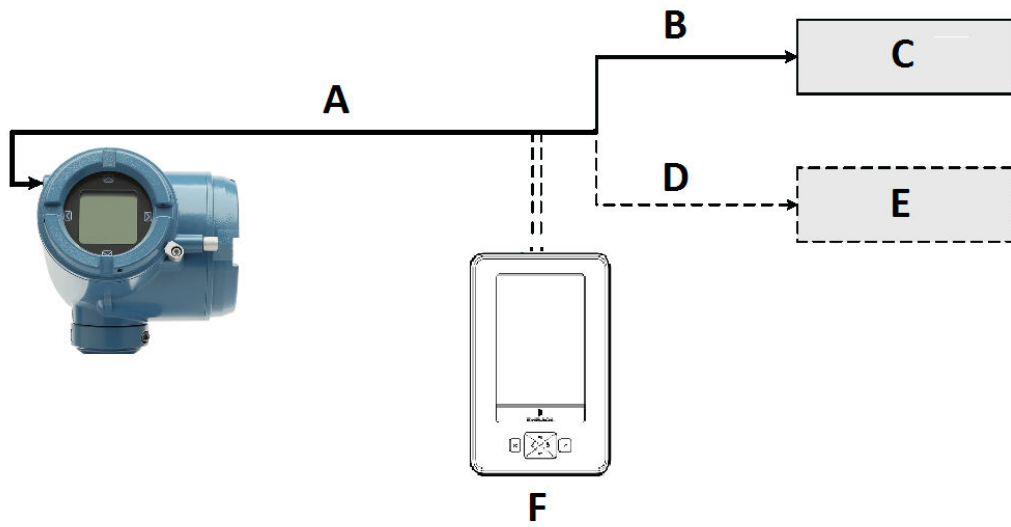

- A. 2-wire cable power and signal
- B. 4-20 mA
- C. mA receiving device
- D. HART<sup>®</sup> variables
- E. Distributed Control System (DCS)
- F. Emerson AMS Trex communicator

### Connection example for cases where a barrier is required

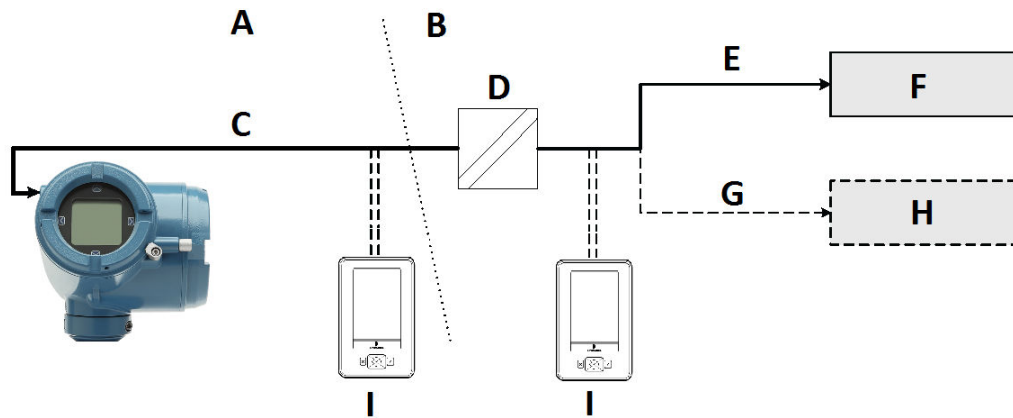

- A. Hazardous area
- B. Safe area
- C. 2-wire cable power and signal
- D. Barrier
- E. 4-20 mA
- F. mA receiving device
- G. HART variables
- H. Distributed Control System (DCS)
- I. Emerson AMS Trex communicator

## Applications

Applications are custom-designed software available to offer additional functionality and performance to transmitters. These applications are available through options in the transmitter model code. See [Ordering information](#) for details.

### Smart Meter Verification

- Provides a quick, complete assessment of a Coriolis meter, determining whether the meter has been affected by erosion, corrosion, or other influences affecting meter calibration
- A basic version of Smart Meter Verification is included with the 4200 transmitter that provides simple pass/fail results.

### Petroleum measurement and API correction option

- Accepts inputs from temperature and pressure devices
- Calculates values as per May, 2004 API Chapter 11.1
  - Relative density (specific gravity and API gravity) at reference temperature from observed density and temperature
  - Volume corrected to reference temperature and pressure
- Calculates flow-weighted average temperature and flow-weighted average observed density (specific gravity and API gravity)

### Concentration measurement

Provides concentration measurement based on either industry-specific or liquid-specific units and relationships. Standard measurement options include:

- Industry-specific:
  - °Brix
  - °Plato
  - °Balling
  - °Baumé at SG60/60
  - Specific gravity
- Liquid-specific:
  - % HFCS
  - Concentration derived from reference density
  - Concentration derived from specific gravity

Additionally, the application can be customized for site-specific concentration measurement (such as %HNO<sup>3</sup>, %NaOH).

## Electrical connections

Connection type	Transmitter
Input/Output	<ul style="list-style-type: none"> <li>■ Two pairs of wiring terminals for transmitter input/output, digital communications, and power</li> <li>■ Screw terminals accept solid or stranded conductors, 26 AWG (0.129 mm<sup>2</sup>) to 14 AWG (2.08 mm<sup>2</sup>).</li> <li>■ Note that all power to the electronics is supplied over the primary 4 - 20 mA signal wiring (Channel A).</li> </ul>
Digital communications administrative connection	<ul style="list-style-type: none"> <li>■ Two clips inside the terminal cover for a temporary connection to HART/Bell 202 terminals.</li> <li>■ Loop resistance is required and must be present in the main I/O loop, but not physically on the main terminal block.</li> </ul>

## Input/output signal detail

Transmitter code	Descriptions
Channel A	<p>One passive 4-20mA output with HART®</p> <ul style="list-style-type: none"> <li>■ Isolated to ±50 VDC from earth ground</li> <li>■ Maximum load limit: 600 Ω</li> <li>■ External power: 17.8 to 30 VDC.</li> <li>■ Can report mass flow, volume flow, gas standard volume flow, temperature, or density</li> <li>■ Milliamp output is NE-43 compliant</li> <li>■ Note that all power to the electronics is supplied over the primary 4 - 20 mA signal wiring (Channel A).</li> </ul>

Transmitter code	Descriptions
Channel B	<p>One passive 4-20mA or frequency or discrete output (Optional Licensed Channel)</p> <ul style="list-style-type: none"> <li>▪ Isolated to <math>\pm 50</math> VDC from earth ground</li> <li>▪ Maximum load limit: 600 <math>\Omega</math></li> <li>▪ External power: 7 to 30 VDC</li> <li>▪ Can report mass flow, volume flow, gas standard volume flow, temperature, or density</li> <li>▪ Milliamp output is NE-43 compliant</li> <li>▪ Note that Channel B requires its own power source independent from Channel A.</li> </ul>

## Digital communications

Connection type	Transmitter
HART® Bell 202	<p>The HART signal is superimposed on the milliamp output, and is available for host system interface:</p> <ul style="list-style-type: none"> <li>▪ Frequency: 1.2 and 2.2 kHz</li> <li>▪ Amplitude: up to 1.0 mA</li> <li>▪ 1200 baud, one stop bit, odd parity</li> <li>▪ Address: 0 (default), configurable</li> <li>▪ Requires 250 to 600 Ohms resistance</li> </ul>

## Environmental limits

### Aluminum housing

Type	Ambient temperature limits
Operating	-40 °F (-40.0 °C) to 149 °F (65.0 °C)
Storage	-40 °F (-40.0 °C) to 185 °F (85.0 °C)

### Stainless steel housing

Type	Ambient temperature limits
Operating	-40 °F (-40.0 °C) to 140 °F (60.0 °C)
Storage	-40 °F (-40.0 °C) to 185 °F (85.0 °C)

### Vibration limits

Meets IEC 60068-2-6, endurance sweep, 5 to 2000 Hz up to 1.0 g.

### Housing rating

Type	Value
Transmitter	NEMA 4X ( IP66/67/69k) polyurethane-painted cast aluminum

**Humidity limits**

The humidity limits are 5 to 95% relative humidity, non-condensing between -40 °F (-40.0 °C) to 149 °F (65.0 °C).

## Environmental effects

**EMI effects**

- Complies with EMC directive 2014/30/EU per EN 61326 Industrial
- Complies with NAMUR NE-21 (2017-08-01)

**Note**

For more information, please contact the factory for the certificate of conformance.

- These standards include surge and transient testing. The 4700 incorporates internal protection against surge and transient events.



**Ambient temperature effect**

- On analog outputs: ±0.0025% of span per °C change from the temperature at which the outputs were trimmed.

## Hazardous area classifications

### Hazardous area classifications

Approval Type	Approval	
CSA C-US		XP: <ul style="list-style-type: none"> <li>■ CLASS I, DIV. 1, Groups C, D</li> <li>■ CLASS I, DIV. 2, Groups A, B, C, D</li> <li>■ CLASS II, Div. 1, Groups E, F, and G</li> </ul> IS: <ul style="list-style-type: none"> <li>■ CLASS I, DIV. 1, Groups A, B, C, D</li> <li>■ CLASS I, DIV. 2, Groups A, B, C, D</li> <li>■ CLASS II, Div. 1, Groups E, F, and G</li> </ul> NI: <ul style="list-style-type: none"> <li>■ CLASS I, DIV. 2, Groups A, B, C, D</li> <li>■ CLASS II, Div. 2, Groups F, and G</li> </ul>

Approval Type	Approval	
ATEX		<ul style="list-style-type: none"> <li>▪ II 2(1)G Ex db [ia Ga] IIC T6 Gb</li> <li>▪ II 2(1)D Ex tb [ia Da] IIIC T72°C Db</li> <li>▪ IP66/IP67</li> </ul> <p>or</p> <ul style="list-style-type: none"> <li>▪ II 2(1)G Ex db eb [ia Ga] IIC T6 Gb</li> <li>▪ II 2(1)D Ex tb [ia Da] IIIC T72°C Db</li> <li>▪ IP66/IP67</li> </ul> <p>or</p> <ul style="list-style-type: none"> <li>▪ II 1G Ex ia IIC T4 Ga</li> <li>▪ II 1D Ex ia IIIC T77°C Da</li> <li>▪ IP66/IP67</li> </ul>
		<ul style="list-style-type: none"> <li>▪ II 3(1)G Ex ec [ia Ga] IIC T6 Gc</li> <li>▪ II 3(1)D Ex tc [ia Da] IIIC T72°C Dc</li> <li>▪ IP66/IP67</li> </ul>
IECEX		<p>IECEX Z1 Ex d:</p> <ul style="list-style-type: none"> <li>▪ Ex db [ia Ga] IIC T6 Gb</li> <li>▪ Ex tb [ia Da] IIIC T72°C Db</li> <li>▪ IP66/IP67</li> </ul> <p>IECEX Z1 Ex de:</p> <ul style="list-style-type: none"> <li>▪ Ex db eb [ia Ga] IIC T6 Gb</li> <li>▪ Ex tb [ia Da] IIIC T72°C Db</li> <li>▪ IP66/IP67</li> </ul> <p>IECEX Z0/1 Ex ia:</p> <ul style="list-style-type: none"> <li>▪ Ex ia IIC T4 Ga</li> <li>▪ Ex ia IIIC T77°C Da</li> <li>▪ IP66/IP67</li> </ul> <p>IECEX Z2 Ex ec:</p> <ul style="list-style-type: none"> <li>▪ Ex ec [ia Ga] IIC T6 Gc</li> <li>▪ Ex tc [ia Da] IIIC T72°C Dc</li> <li>▪ IP66/IP67</li> </ul>

## Physical specifications

### Transmitter

Specification	Value
Housing	NEMA 4X (IP66/67) polyurethane-painted cast aluminum or 316L stainless steel. Available with ½ in NPT or M20 conduit connections



Specification	Value
Weight	See the sensor product data sheet for combined weight of the flowmeter: <ul style="list-style-type: none"> <li>▪ Integral mount version 6.48 lb (2.939 kg)</li> <li>▪ Remote mount version 8.21 lb (3.724 kg)</li> <li>▪ Stainless steel integral mount version 14.5 lb (6.58 kg)</li> <li>▪ Stainless steel remote version without mounting bracket 19.7 lb (8.94 kg)</li> <li>▪ Stainless steel remote mount version 21.7 lb (9.84 kg)</li> </ul>
Cable gland entrances	Two ½ in -NPT or M20 x1.5 female conduit port
Mounting	<ul style="list-style-type: none"> <li>▪ Available integrally mounted to the following Coriolis sensors:                             <ul style="list-style-type: none"> <li>— CMF200 - CMF350<sup>(1)</sup></li> <li>— CMFS007 - CMFS150</li> <li>— F025-F400</li> <li>— H025-H400</li> <li>— R025-R300</li> <li>— T025-T150</li> </ul> </li> <li>▪ Available as a remote mount transmitter for the following Coriolis sensors:                             <ul style="list-style-type: none"> <li>— CMF010 - CMF350</li> <li>— CMFS007- CMFS150</li> <li>— F025 - F400</li> <li>— H025 - H400</li> <li>— R025-R300</li> <li>— T075 - T150</li> </ul> </li> <li>▪ Available as a stainless steel transmitter for the following Coriolis sensors:                             <ul style="list-style-type: none"> <li>— CMFS007- CMFS150</li> <li>— F025 - F400</li> <li>— H025 - H400</li> <li>— R025-R300</li> <li>— T075 - T150</li> </ul> </li> <li>▪ High temperature sensors are not compatible with the 4200 transmitter.</li> <li>▪ The transmitter can be rotated on the mounting in 45 degree increments.</li> </ul>
Interface/display <div style="text-align: center;">  </div>	Standard user interface with LCD panel <ul style="list-style-type: none"> <li>▪ Suitable for hazardous area installation</li> <li>▪ User interface module can rotate 360° in 90° increments by software selection</li> <li>▪ Four capacitive buttons for local operation without removing transmitter housing cover</li> <li>▪ Display can be configured to scroll through displayed variables at user-specified rate</li> <li>▪ Display update rate is user-configurable: 500 to 10,000 milliseconds</li> </ul>

(1) Aluminum housing only.

## Dimensions

### 4200 transmitter aluminum painted housing integral installation

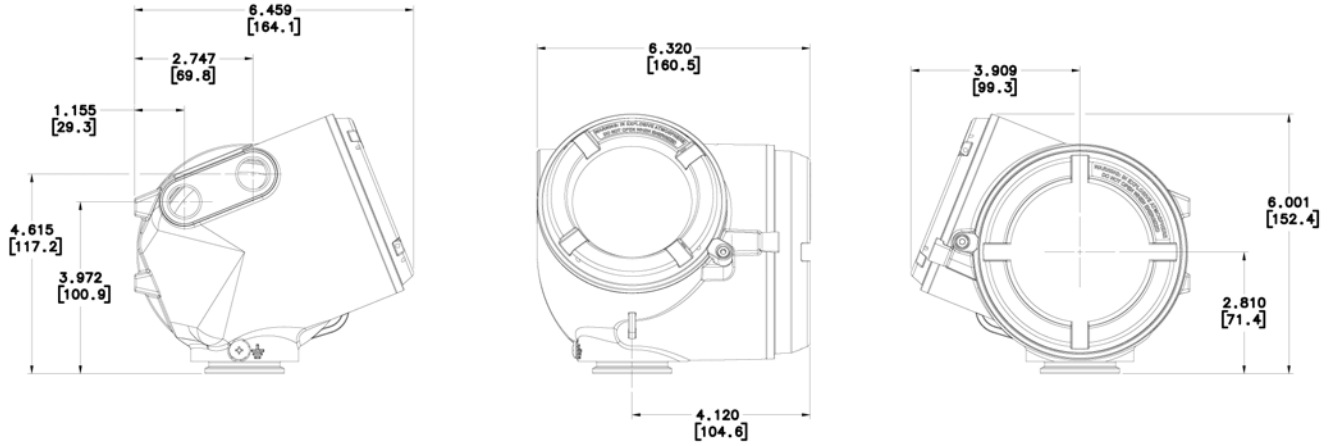

Dimensions are in inches [mm]

### 4200 transmitter stainless steel housing integral installation

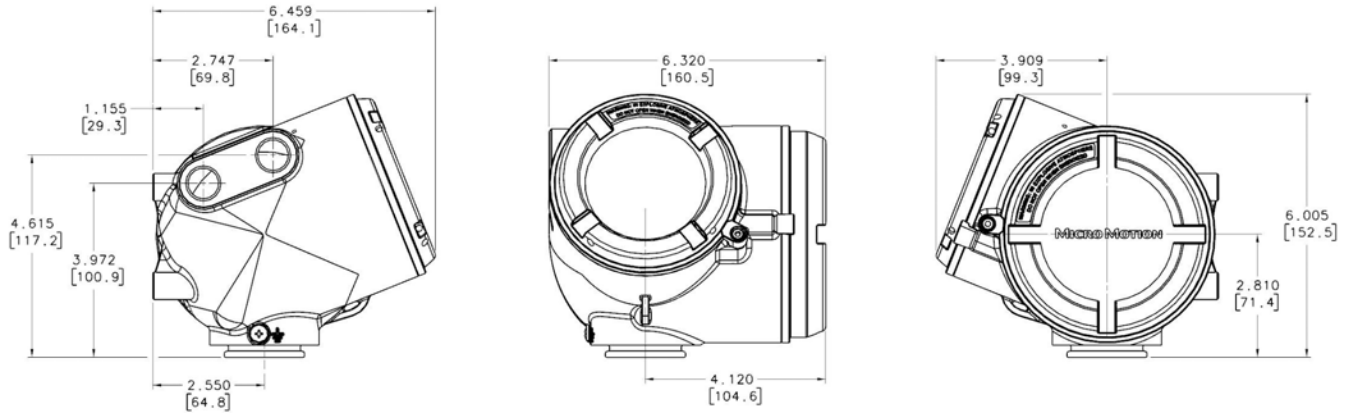

Dimensions are in inches [mm]

4200 transmitter aluminum painted housing remote installation

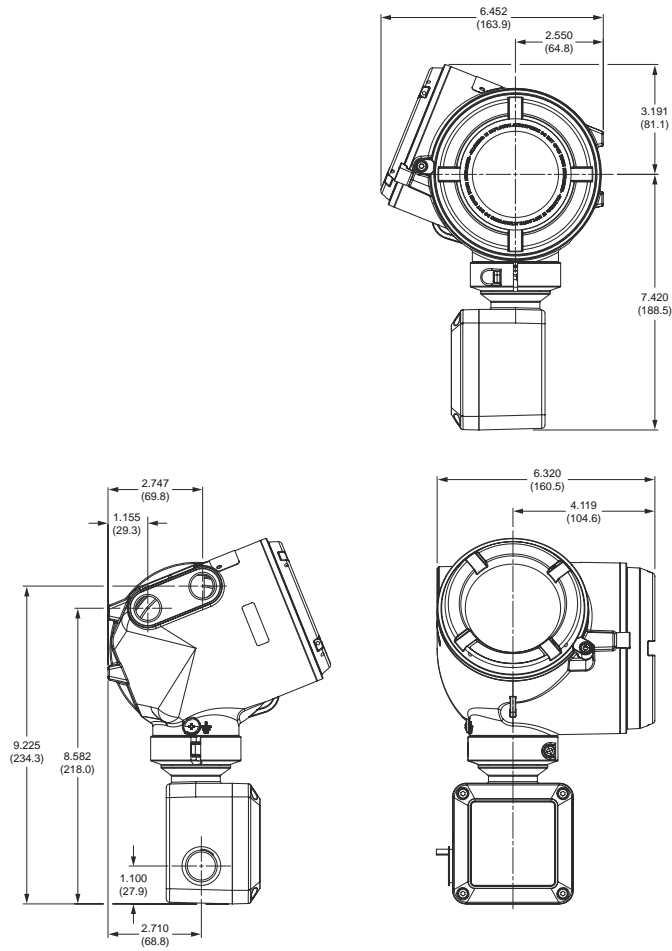

Dimensions are in inches [mm]

4200 transmitter stainless steel housing remote installation

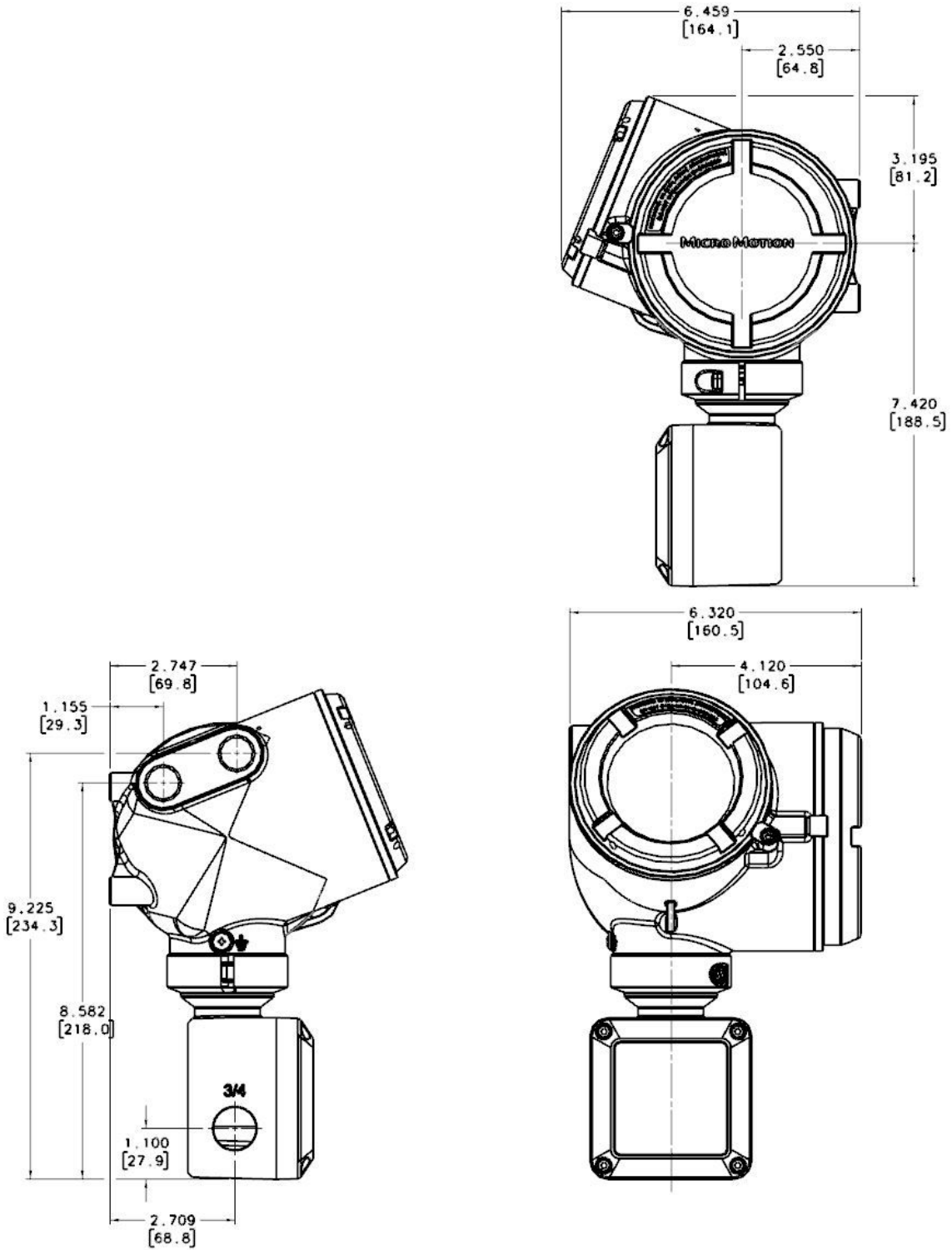

Dimensions are in inches [mm]

## 4200 with Smart Wireless THUM™ Adapter

The 4200 transmitter is available with the Smart Wireless THUM Adapter using order option code NI (THUM ordered separately and not assembled to the 4200 transmitter). Refer to the [Add on options](#) table.

# Ordering information

## 4200

### Base model

Model	Product description
4200	4200 Micro Motion Field Mount Loop-Powered Transmitter

### Mounting

Code	Options for 4200
I	Integral mount transmitter (polyurethane-painted aluminum housing)
C	9-wire remote mount transmitter (polyurethane-painted aluminum housing), 316 stainless steel bracket for wall or pipe mounting and hardware for 2" (50.8 mm) pipe mount; Includes 10ft. (3M) of CFEPS cable
J	Integral mount transmitter (316L stainless steel housing)
P	9-wire remote mount transmitter (316L stainless steel housing), 316 stainless steel bracket for wall or pipe mounting and hardware for 2" (50.8 mm) pipe mount; Includes 10ft. (3M) of CFEPS cable

### Power

Code	Power options
1	Loop Powered

### Display

Code	Transmitter display options
<b>Available with all approval codes</b>	
2	Dual-line display for process variables and totalizer reset
3	No display
<b>Available with approval code MA</b>	
7	Non-glass dual-line display for process variables and totalizer reset

### Output Hardware Board

Code	Output Hardware Board
A	4-20mA (Loop Powered)

**Conduit connection**

Code	Conduit connection options
B	1/2-inch NPT -- no gland
C	1/2-inch NPT with brass nickel cable gland
D	1/2-inch NPT with stainless steel cable gland
E	M20 -- no gland
F	M20 with brass nickel cable gland
G	M20 with stainless steel cable gland
K	JISB0202 1/2G -- no gland
L	Japan -- brass nickel cable gland
M	Japan -- stainless steel cable gland

**Approval**

Code	Approval options
MA	Micro Motion Standard (no approval)
AA	CSA (US and Canada): Class I, Div. 1 Ex Proof
AB	CSA (US and Canada): Class I, Div. 1 Intrinsically Safe
ZA	ATEX: II 2G, Ex de, Zone 1 and II 2D Ex tb, Zone 21
FA	ATEX: II 2G, Ex d, Zone 1 and II 2D Ex tb, Zone 21
ZB	ATEX: II 1G, Ex ia, Zone 0/Zone 1 and II 1D, Ex ia, Zone 20/Zone 21
IA	IECEX: EPL Gb, Ex d, Zone 1 and EPL Db, Ex tb, Zone 21
EA	IECEX: EPL Gb, Ex de, Zone 1 and EPL Db, Ex tb, Zone 21
EB	IECEX: EPL Ga, Ex ia, Zone 0/Zone 1 and EPL Da, Ex ia, Zone 20/Zone 21
2A	CSA (US and Canada): Class I, Div. 2
VA	ATEX: II 3G, Ex ec, Zone 2 and II 3D Ex tc Zone 22
3A	IECEX: EPL Gc, Ex ec, Zone 2 and EPL Dc, Ex tc Zone 22
R1	EAC: Ex de, Zone 1
R2	EAC: Ex d, Zone 1
R3	EAC: nA, Zone 2
R5	EAC: Ex ia, Zone 1

**Transmitter option 1**

Code	Transmitter Option 1
Z	Standard

**Transmitter option 2**

Code	Transmitter Option 2
Z	Standard

**Factory options**

Code	Factory options for 4200
Z	Standard product
X	ETO product

**Output channel A assignment**

Code	Output channel A assignment
<b>Available with A Output Hardware Board</b>	
A	Channel A : 4-20mA/HART® (Loop Powered)

**Output channel B assignment**

Code	Output channel B assignment
<b>Available with A Output Hardware Board</b>	
A	Channel B : One passive 4-20mA output, or frequency output, or discrete output (optional)
Z	Channel OFF

**Add on Options**

Code	Add on options (all are optional, none mandatory)
<b>Instrument Tagging</b>	
TG	Instrument -- customer information required (maximum 24 characters)
<b>Meter Verification</b>	
MV	Smart Meter Verification Available with all mounting options, but Mounting C is limited to 60 ft (20m) of 9-wire cable and only available when purchased with a new 9-wire sensor
<b>Enhanced Measurement (select only one from this group)</b>	
PS	API Referral Software
CM	Concentration Measurement Software
<b>Additional Certifications, Requires "A" option</b>	
SI	Safety certification of 4-20 mA output per IEC 61508 Only Channel A is certified.
<b>Smart Wireless 775 THUM™ Ready, Requires "A" board option</b>	
NI	Smart Wireless 775 THUM Ready -- 775 ordered separately and not assembled to the 4200 transmitter

For more information: [Emerson.com/global](https://emerson.com/global)

©2024 Micro Motion, Inc. All rights reserved.

The Emerson logo is a trademark and service mark of Emerson Electric Co. Micro Motion, ELITE, ProLink, MVD and MVD Direct Connect marks are marks of one of the Emerson Automation Solutions family of companies. All other marks are property of their respective owners.