

NEOTECHA HIGH TEMP IN-LINE SAMPLING SAPRO[®]

Sapro HT sampling valve for representative sampling without process interruption suitable for high temperature applications up to 350°C (662°F)



FEATURES

- The High Temperature sampling valve assures a 'true representative sample' every time without process interruption because it is installed directly into a process pipeline.
- The operation of the sampling valve is simple and safe and designed for temperatures up to 350°C continuously.
- A bellow sealed primary spindle seal.
- Standard provided with leak detection ports.
- Available in wafer and flanged body style.
- Low cost of ownership due to the ease of assembly and disassembly for cleaning and maintenance.
- A hard faced knife edge seating surface Stellite-21 to cut through process impurities.
- Smooth operation due to an axial needle bearing.
- Standard bottle adaptor provided with ISO GL 45 thread and G 1/8" vent connection. Customer bottle threads are available on request.
- Optional safety cabinet and bottle support table.

GENERAL APPLICATIONS

The Sapro HT is designed for thermal oil applications and other high temperature services.

In general thermal oil is highly volatile, has a low viscosity and is combustible. The Sapro HT is designed to reduce emissions to avoid potential fire hazards.

TECHNICAL DATA

Size (DN):	25 - 100
Pressure (bar):	Max. 16
Body styles:	Wafer and lugged (ANSI/DIN)
Temperature (°C):	Max. 350 continuously
Borosilicate glass bottles:	Max. 500°C ΔT max. 100°C

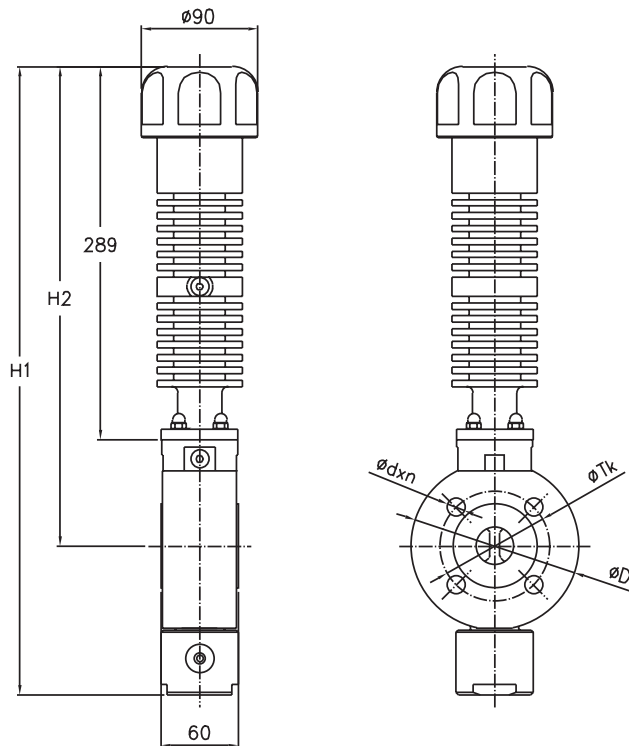

DIMENSIONS

Size DN	Size NPS	H1	H2	ØD	ØTk	ØTk	Ød*n	Ød*n	Weight (kg)	Item number
				DIN	ANSI	DIN	ANSI			
25	1"	487	372	130	85	79.4	4x14	4x16	12.5	SH025D2103A5B00
40	1½"	503	380	150	110	98.4	4x18	4x16	13.3	SH040D2103A5B00
50	2"	514	386	165	125	120.6	4x18	4x19	14.2	SH050D2103A5B00
65	2½"	532	396	176	145	139.7	4x18	4x19	16.5	SH065D2103A5B00
80	3"	545	403	190	160	152.4	8x18	4x19	17.8	SH080D2103A5B00
100	4"	572	418	220	180	190.5	8x18	8x19	19.5	SH100D2103A5B00

APPLICATION EXAMPLES FOR THERMAL OIL

- Typical systems
 - Heat exchangers
 - Dryers
 - Jacketed kettles
- Chemical and petrochemical industry
 - Asphalt products
 - Rubber and tire industries
 - Soap and detergents
 - Paints and coatings
 - Solvent recovery
 - Resins
- Polymer processing
 - Polyethylene
 - Polypropylene
 - PVC/PET
 - Polyamide and polyester fibers

MANUALLY OPERATED BOTTLE SAMPLING

The HT sampling valve is a simple, safe and effective method to take samples of corrosive, high temperature media. The operation is achieved by a non-rising multi turn hand wheel, which lifts the valve spindle from its metal seat. The sample media can now flow into the bottle. The displaced air in the empty bottle can be released to a plant scrubbing or venting system using a G 1/8" connection on the bottle adaptor, as the bottle is filled.

The standard bottle adaptor is provided with an ISO GL 45 thread and a G 1/8" vent connection.

Adaptors are available per customer's bottle threading upon request.

The standard discharge diameter of the bottle adaptor is 4 mm and can be enlarged up to 12 mm for high viscosity medias.

NEOTECHA HIGH TEMP IN-LINE SAMPLING SAPRO®

Material specification

1	Handwheel	Anodized aluminium
2	Belleville spring package	Spring steel
3	Gland	Bronze
4	Secondary spindle seal	Graphite
5	Leak detection port	Thread G 1/8"
6	Body heat extension	Stainless steel 1.4305
7	Spindle	Stainless steel 1.4435 Hastelloy C-276
8	Two layer Bellow seal	Stainless steel 1.4571 Hastelloy C-276
9	Body	Stainless steel 1.4435 Hastelloy C-276
10	Spindle	Stainless steel 1.4435 / Stellite 21 coated Hastelloy C-276 / Stellite 21 coated
11	Seat	Stainless steel 1.4435 Hastelloy C-276
12	Soft seals	Graphite reinforced with Hastelloy C-276
13	Bottle adaptor	Stainless steel 1.4435 Hastelloy C-276
14	Vent	Thread G 1/8"

Other materials on request

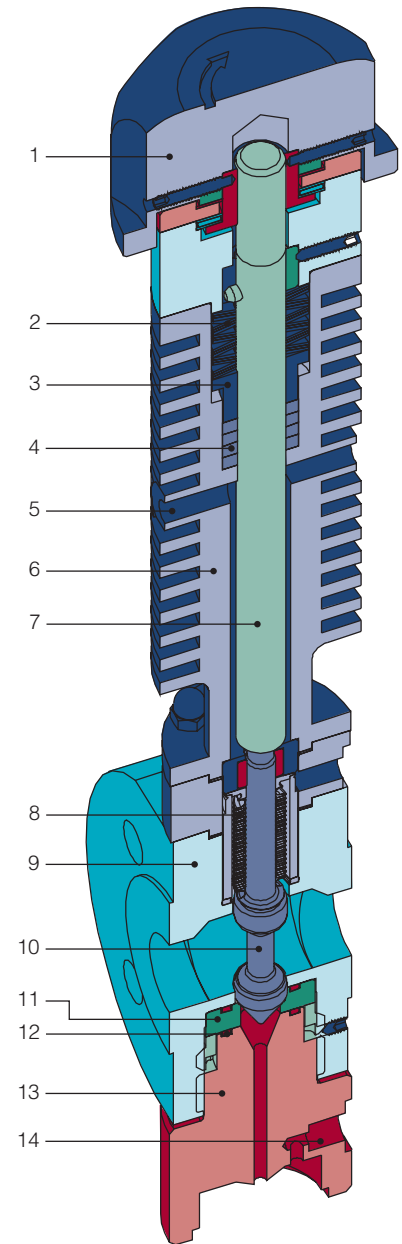

Neither Emerson, Emerson Automation Solutions, nor any of their affiliated entities assumes responsibility for the selection, use or maintenance of any product. Responsibility for proper selection, use, and maintenance of any product remains solely with the purchaser and end user.

Neotecha is a mark owned by one of the companies in the Emerson Automation Solutions business unit of Emerson Electric Co. Emerson Automation Solutions, Emerson and the Emerson logo are trademarks and service marks of Emerson Electric Co. All other marks are the property of their respective owners.

The contents of this publication are presented for informational purposes only, and while every effort has been made to ensure their accuracy, they are not to be construed as warranties or guarantees, express or implied, regarding the products or services described herein or their use or applicability. All sales are governed by our terms and conditions, which are available upon request. We reserve the right to modify or improve the designs or specifications of such products at any time without notice.

Emerson.com/FinalControl