



CLARKSON FIGURE PCS17
KNIFE GATE VALVES

Bi-directional zero leakage knife gate valve. The new standard for innovation and performance with its drop-in new generation perimeter seat, that ensures zero leakage in either direction



FEATURES

- Unique drop-in next-generation perimeter cartridge seats ensure zero leakage and quick and cost-effective maintenance resulting in lower cost of ownership.
- Re-engineered seat geometry and a new precision moulding process ensure zero water leakage at low or high pressures.
- Seat material is available a variety of materials including EPDM, Viton (FKM), Nitrile (NBR).
- The seat is in-line replaceable.
- Solid cast, one piece body in 316 stainless steel. Designed and qualified through FEA analysis for optimum performance and reliability.
- Four post yoke design makes it easier to make packing adjustments and is more efficient for seat repair/replacement. Also makes actuator retro-fitting quick and easy.
- Built to industry standards including; MSS SP-81 face to face and full port design to Schedule 40.

GENERAL APPLICATION

- Waste water
- Mining
- Power
- Chemical
- Petrochemical
- General process

TECHNICAL DATA

Size range: DN 50 - 750 (NPS 2 - 30)
 Temperature rating: 150°C (300°F) EPDM (std)
 120°C (250°F) NBR
 205°C (400°F) FKM
 Pressure rating: DN 50 - 600 = 1034 kPa
 (NPS 2 - 24 = 150 psi)
 DN 750 = 690 kPa
 (NPS 30 = 100 psi)
 at ambient temperature
 End connections: MSS SP-81 Face to face

CLARKSON FIGURE PCS17

KNIFE GATE VALVES

OPTIONS

- Handwheel (standard)
- Bevel gear operators
- Non-rising stem actuator
- Cable lockout for manual handwheel valves
- Lock-pin style lockouts for open/closed positions
- Pneumatic/hydraulic/spring cylinders
- Electric actuators
- Control accessories
- Extension stems, floorstands, stem guides
- Safety guards and shrouds

VALVE BENEFITS

STANDARD SEAT DETAIL

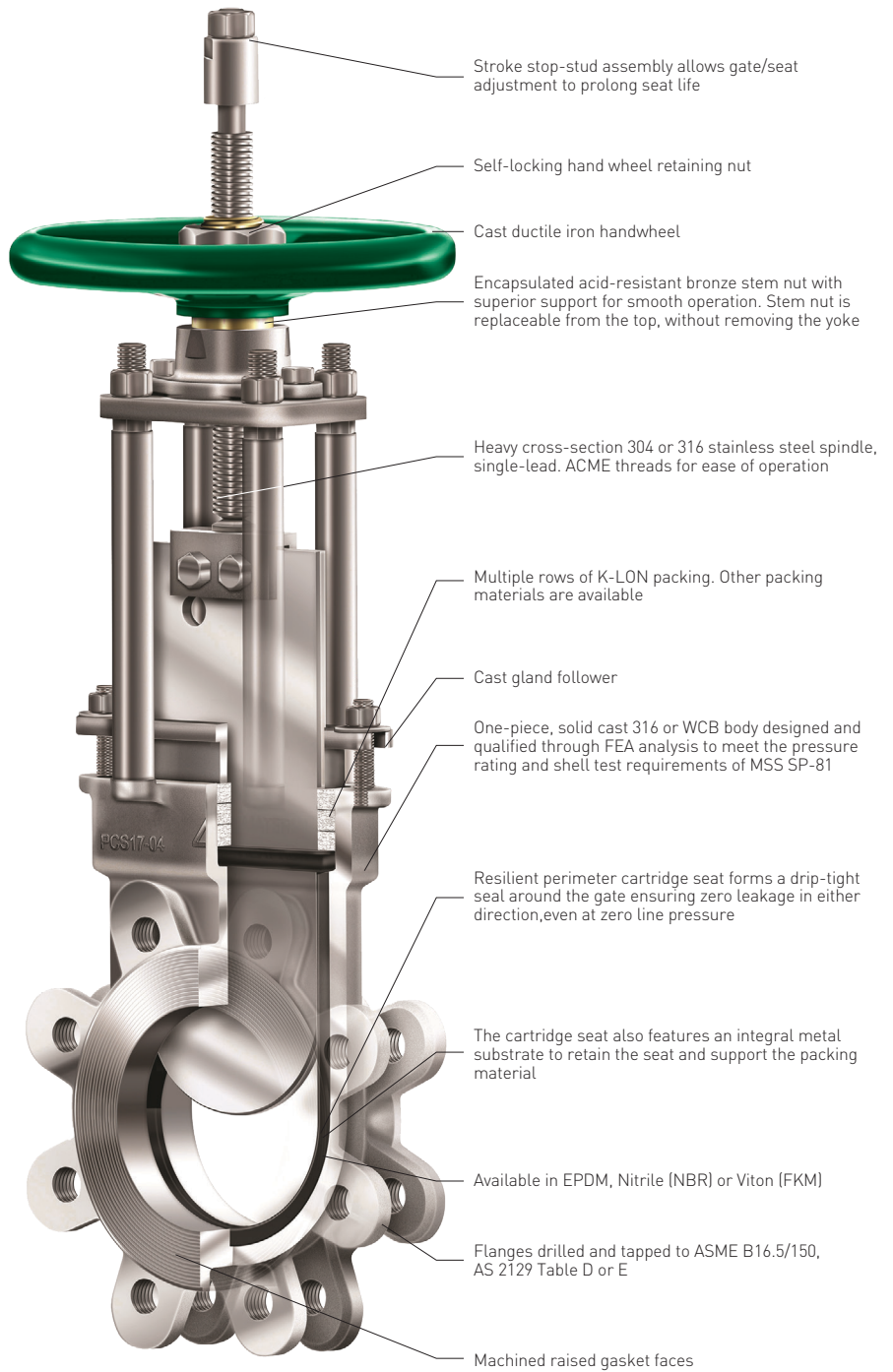
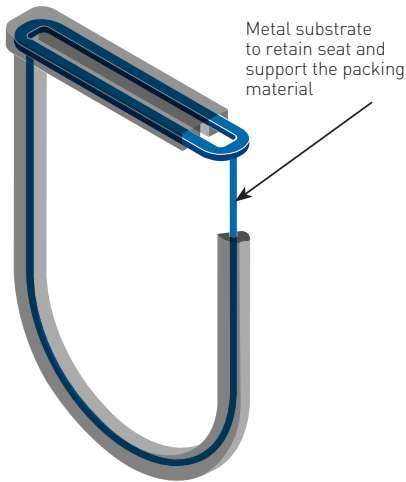
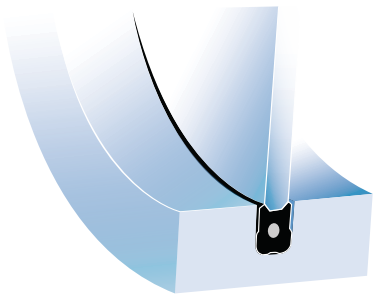

CLARKSON FIGURE PCS17

KNIFE GATE VALVES

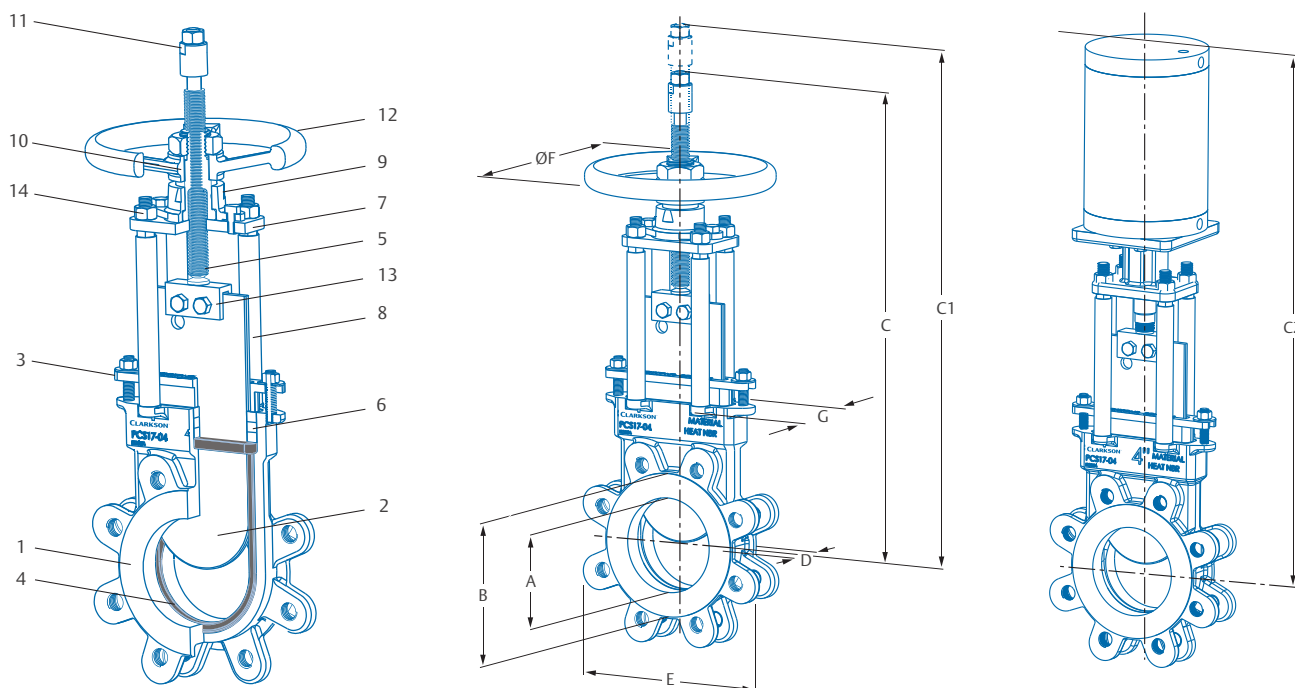

PARTS LIST

No.	Description	Material	No.	Description	Material
1	Body	316 S/S	8	Yoke post	316 S/S
2	Gate	316 S/S	9	Bushing retainer	304 S/S
3	Gland follower	316 S/S	10	Stem nut	Bronze
4	Seat	EPDM , Nitrile, FKM	11	Stroke adjustment nut	304 S/S
5	Spindle	316 S/S	12	Handwheel	Iron
6	Gland packing	K-LON	13	Clevis	316 S/S
7	Yoke top plate	316 S/S	14	Fasteners	304 S/S

DIMENSIONS mm (inches)

Valve size DN (NPS)	Bore		Rising spindle		Mass						
	A	ASME 150 B	[closed] C	[open] C1	C2	D	E	ØF	G	kg (lbs)	K _v * [C _v ❖] at full open
50 (2)	51 (2.00)	92 (3.62)	362 (14.25)	419 (16.50)	438 (17.25)	48 (1.88)	152 (6.0)	305 (12)	70 (2.75)	11.8 (26)	246 (284)
80 (3)	76 (3.00)	127 (5.00)	406 (16.00)	486 (19.13)	527 (20.75)	51 (2.00)	191 (7.5)	305 (12)	73 (2.88)	13.6 (30)	587 (678)
100 (4)	102 (4.00)	157 (6.19)	454 (17.88)	559 (22.00)	600 (23.63)	51 (2.00)	229 (9.0)	305 (12)	73 (2.88)	16.8 (37)	1109 (1281)
150 (6)	152 (6.00)	216 (8.50)	597 (23.50)	756 (29.75)	783 (30.81)	57 (2.25)	279 (11.0)	406 (16)	89 (3.50)	27.7 (61)	2753 (3180)
200 (8)	203 (8.00)	270 (10.62)	699 (27.50)	895 (35.25)	978 (38.50)	70 (2.75)	343 (13.5)	508 (20)	89 (3.50)	38.1 (84)	4711 (5441)
250 (10)	254 (10.00)	324 (12.75)	810 (31.88)	1067 (42.00)	1143 (45.00)	70 (2.75)	406 (16.0)	508 (20)	127 (5.00)	63.1 (139)	7766 (8970)
300 (12)	305 (12.00)	381 (15.00)	927 (36.50)	1232 (48.50)	1362 (53.63)	76 (3.00)	483 (19.0)	508 (20)	127 (5.00)	86.2 (190)	11742 (13562)
350 (14)	333 (13.12)	413 (16.25)	1026 (40.38)	1359 (53.50)	1549 (61.00)	76 (3.00)	533 (21.0)	508 (20)	127 (5.00)	130.2 (287)	13401 (15478)
400 (16)	381 (15.00)	470 (18.50)	1130 (44.50)	1511 (59.50)	1699 (66.88)	89 (3.50)	597 (23.5)	508 (20)	178 (7.00)	171.9 (379)	16965 (19594)
450 (18)	429 (16.88)	533 (21.00)	1232 (48.50)	1664 (65.50)	1851 (72.88)	89 (3.50)	635 (25.0)	-	267 (10.50)	252.2 (556)	21247 (24540)
500 (20)	478 (18.81)	584 (23.00)	1346 (53.00)	1826 (71.88)	2019 (79.50)	114 (4.50)	711 (28.0)	-	289 (11.38)	332.0 (732)	26452 (30552)
600 (24)	575 (22.62)	692 (27.25)	1581 (62.25)	2159 (85.00)	2353 (92.63)	114 (4.50)	838 (33.0)	-	397 (15.63)	477.2 (1052)	38872 (44897)
750 (30)	730 (28.75)	857 (33.75)	2083 (82.00)	2661 (104.75)	-	117 (4.63)	978 (38.5)	-	356 (14.00)	872.3 (1923)	66850 (77212)

NOTE

Dimension D = The face to face dimension.

Dimension E = The maximum valve or upstand clearance dimension for installation.

* K_v = The flow rate of water in m³/hr that will pass through a valve with a differential pressure of 1 bar (100 kPa) at 20°C.

❖ C_v = The volume of water in US gpm that will pass through a valve with a differential pressure of 1 psi at 60°F.

C_v = 1.155 K_v

Dimensions are nominal.

DN 450 (NPS 18) and larger are with bevel gear operator.

CLARKSON FIGURE PCS17

KNIFE GATE VALVES

PRESSURE/TEMPERATURE GRAPH (DN 50 - 600 (NPS 2 - 24) ONLY)

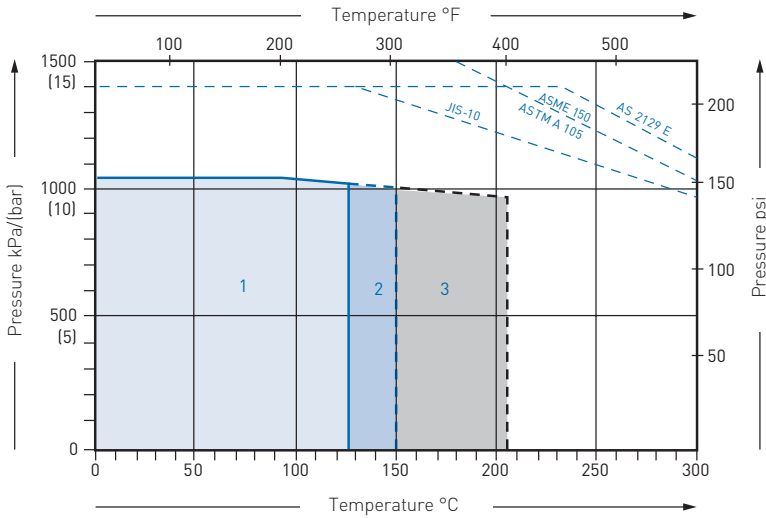

PRESSURE/TEMPERATURE RATINGS

Nitrile seated

1034 kPa/10.3 bar (150 psi) at 100°C (212°F)
1020 kPa/10.2 bar (148 psi) at 120°C (250°F)

EPDM seated

1034 kPa/10.3 bar (150 psi) at 100°C (212°F)
1006 kPa/10.0 bar (146 psi) at 150°C (300°F)

FKM seated

1034 kPa/10.3 bar (150 psi) at 100°C (212°F)
1000 kPa/10.0 bar (145 psi) at 205°C (400°F)

1. Nitrile seated valve trim code number is 521
2. EPDM seated valve trim code number is 520
3. FKM seated valve trim code number is 522

NOTE

To minimize risk to personnel, Emerson recommend the use of purpose built guards and shrouds. Refer to the Emerson data sheet or consult factory for details.

SELECTION GUIDE

Example:	250 (10)	PCS17	520	AS 2129 E
Valve size	DN 50 - 750 (NPS 2 - 30)			
Figure number	PCS17 Resilient perimeter seat			
Trim code	See table			
End connections	AS 2129 E or ASME 150			

Trim code	Body	Gate	Seat	Gland			
				follower	Bridge	Spindle	Packing
520	316 S/S	316 S/S	EPDM	316 S/S	316 S/S	316 S/S	K-LON
521	316 S/S	316 S/S	Nitrile	316 S/S	316 S/S	316 S/S	K-LON
522	316 S/S	316 S/S	FKM	316 S/S	316 S/S	316 S/S	K-LON

HANDWHEEL ACTUATOR

Nominal valve size DN (NPS)	HW Ø"	Max. recommended line pressure differential			
		kPa	psi	Estimated ⁽¹⁾ Rimpull	
				Kg-f	lb-f
50 (2)	12	1034	150	6	14
80 (3)	12			10	22
100 (4)	12			14	32
150 (6)	16			24	53
200 (8)	20			32	70
250 (10)	20	517	75	29	64
300 (12)	20			41	90
350 (14)	20			44	97
400 (16)	20	241	35	52	115

NOTE

1. Estimations based on internal calculations; actual thrust and torque requirements may vary in the field

© 2010, 2020 Emerson Electric Co. All rights reserved 04/20. Clarkson is a mark owned by one of the companies in the Emerson Automation Solutions business unit of Emerson Electric Co. The Emerson logo is a trademark and service mark of Emerson Electric Co. All other marks are the property of their prospective owners.

The contents of this publication are presented for informational purposes only, and while every effort has been made to ensure their accuracy, they are not to be construed as warranties or guarantees, express or implied, regarding the products or services described herein or their use or applicability. All sales are governed by our terms and conditions, which are available upon request. We reserve the right to modify or improve the designs or specifications of such products at any time without notice.

Emerson Electric Co. does not assume responsibility for the selection, use or maintenance of any product. Responsibility for proper selection, use and maintenance of any Emerson Electric Co. product remains solely with the purchaser.

Emerson.com/FinalControl