



OVERALL SPECIFICATION

FLUID	: Compressed air or neutral gas The compressed air used must be dry to prevent ice buildup
PORTS	: G3/4 to G1 1/2
MAX. INLET PRESSURE	at 23°C : 17,5 bar at 50°C : 12 bar
AMBIENT TEMPERATURE	: -10°C to +50°C (+ 60°C at 12 bar)
MAX. FLOW (P1=10 bar)	: G3/4 = 10400 l/mn - G1 = 11400 l/mn
BOWL CAPACITY	total : 500 cm ³ useful : 300 cm ³



CONSTRUCTION

Filtering capacity 30 µm or 5 µm
 Filtering element of sintered plastic
 Aluminium body
 Metal bowl with polypropylene level viewing window
 Bowl equipped with pipable semi-automatic or automatic drain
 (operating pressure: 2 to **12 bar**) or manual drain as option

CHOICE OF EQUIPMENT

port size	maximum flow (ANR) inlet pressure 8 bar		code					
			filter					
			manual drain ⁽³⁾		semi-automatic drain		automatic drain	
(l/min)	(dm ³ /s)	30 µm	5 µm ⁽¹⁾	30 µm	5 µm ⁽¹⁾	30 µm	5 µm ⁽¹⁾	
Standard filter								
G 3/4	9700	162	34207005	34207017	34207001	34207013	34207009	34207021
G 1	10300	172	34207006	34207018	34207002	34207014	34207010	34207022
G 1 1/4 ⁽²⁾	10300	172	34207007	34207019	34207003	34207015	34207011	34207023
G 1 1/2 ⁽²⁾	10300	172	34207008	34207020	34207004	34207016	34207012	34207024

⁽¹⁾ With a filtering element of 5 µm, the flow is reduced by approx. 15 %
⁽²⁾ The G 1 1/4 and G 1 1/2 versions are composed of a G 1 version + 1 set of 2 G 1 1/4 or G 1 1/2 flanges (1 connecting flange for each end of each component). When assembling several components together (FRL, isolation valve etc...), select G 1 components and provide for 1 set of G 1 1/4 or G 1 1/2 flanges (see "Accessories" pages).
⁽³⁾ Metal manual drain.

OTHER PRODUCT OPTIONS

- [Electronic pressure switch](#)
- [By-pass module](#)

ACCESSORIES (see pages suivantes)

PRESSURE LOSS VERSUS AIR FLOW CURVES

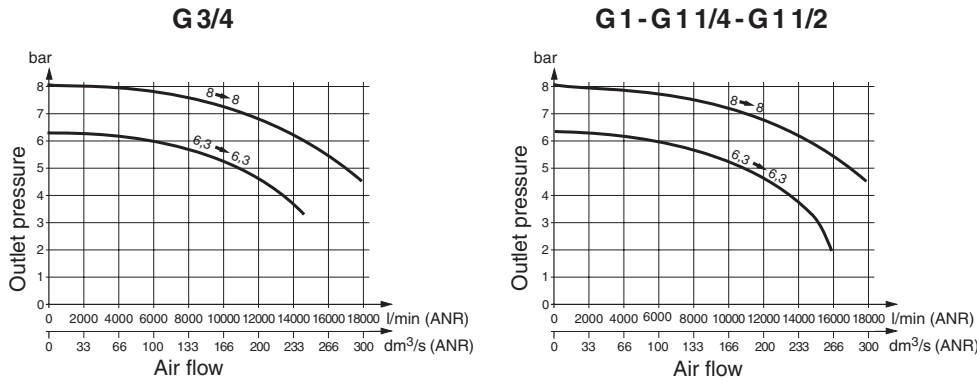

DIMENSIONS AND WEIGHTS - G3/4 - G1 VERSIONS

Weight: 0,9 kg

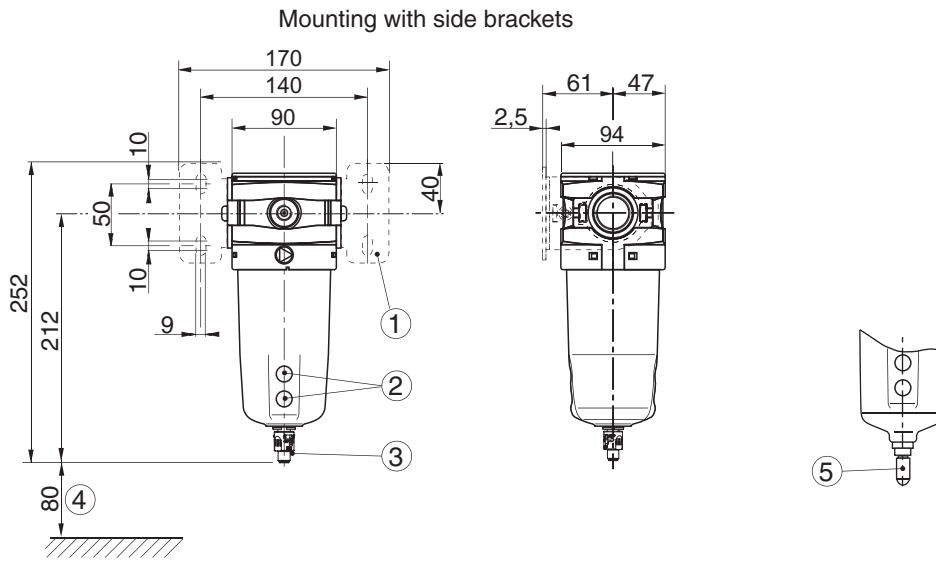

G 1 1/4 - G 1 1/2 versions - see accessories

- ① Mounting with 2 side brackets (accessory)
- ② Condensate level window
- ③ semi-automatic drain connectable G1/8
- ④ Clearance required for bowl removal
- ⑤ Automatic drain connectable to 6 mm ID flexible tubing

INSTALLATION AND MAINTENANCE

Products must be installed with the bowls in vertical position (at the bottom).

Air flow direction indicated by arrow (▶)

Use an alkaline solution (soapy water) and not a solvent for cleaning the polycarbonate bowls and sight glasses.

SPARE PARTS KIT

catalogue number	code pièces de rechange							bowl o'ring (x 1)	
	30 µm	5 µm	semi-automatic drain	automatic drain	semi-automatic	drain automatic	manual (brass)		
34207001...7004	97802778	-	97802780	-	97802900	-	-	97802915	
34207037...7040			-	97802878	-	97801643	-		
34207009...7012			-	-	-	-	97802825		-
34207045...7048			-	-	-	-	-		-
34207005...7008			-	-	-	-	-		-
34207041...7044	-	97802776	97802780	-	97802900	-	-	97802915	
34207013...7016			-	97802878	-	97801643	-		
34207049...7052			-	-	-	-	97802825		-
34207021...7024			-	-	-	-	-		-
34207057...7060			-	-	-	-	-		-
34207017...7020	-	-	-	-	-	97802825	-		
34207053...7056	-	-	-	-	-	-	-		