

# Fisher™ 3660 and 3661 Positioners

Fisher 3660 pneumatic and 3661 electro-pneumatic single-acting positioners are part of the 3660 series of positioners. They are used with various actuators on sliding-stem valves for throttling applications. These rugged positioners provide a valve position proportional to a pneumatic input or a standard milliamper DC input signal received from a control device.

## Features

- **Accurate, Efficient, Vibration-Resistant Operation**—Positioner design provides accurate, fast-responding instruments able to withstand the vibrations of most plant environments. Low steady-state air consumption contributes to efficient operation.
- **Variable Gain**—Easily adjustable gain and damping adjustments fine tune the positioner stability to specific application requirements.
- **Versatility**—Positioner accepts a standard pneumatic input signal (3660) or a standard milliamper DC input signal (3661) from a control device. This positioner provides split range capabilities and adjustable zero and spans.
- **Fewer Spare Parts Required**—Most of the parts for 3660 and 3661 positioners are interchangeable, requiring fewer spare parts to support these positioners.
- **Rugged Construction**—The case and cover are designed to withstand mechanical vibration and rough handling.
- **Easy Positioner Adjustments**—Zero and span adjustments can be made with the cover in place.
- **Control Valve Diagnostic Testing Capability**—To support diagnostic testing of valve/actuator/positioner packages with the FlowScanner™ valve diagnostic system, connectors, piping, and other hardware can be installed between the 3660 or 3661 positioner and the actuator. A typical connector installation is shown in figure 4.



Fisher 3660 Positioner with  
Baumann™ Valve and Actuator

W7174

## Specifications

### Available Configuration

The Fisher 3660 series of positioners include the following models:

**3660:** Single-acting pneumatic valve positioner  
**3661:** Single-acting electro-pneumatic valve positioner

### Input Signal

**3660:**  
■ 0.2 to 1.0 bar (3 to 15 psig), ■ 0.4 to 2.0 bar (6 to 30 psig), or ■ Split range, see table 2  
**3661:**  
■ 4-20 mA DC constant current with 30 VDC maximum compliance voltage ■ Split range is also available, see table 2

### Equivalent Circuit (3661)

120 ohms shunted by three 5.6 V zener diodes

### Output Signal

**Type:** Pneumatic pressure as required by the actuator up to full supply pressure  
**Action:** ■ Direct (increasing input signal increases positioner output), ■ Reverse (increasing input signal decreases positioner output)

### Supply Pressure<sup>(1)</sup>

**Recommended:** 10% above actuator requirements  
**Maximum:** 6.2 bar (90 psig) or pressure rating of actuator, whichever is lower

**Medium:** Air

3660 and 3661 are not compatible with natural gas as the supply medium

### Performance

**Independent Linearity:** ±1% of output span  
**Hysteresis:** 0.5% of output span<sup>(2)</sup>  
**Deadband:** 0.1% of input span

**Electromagnetic Compatibility for 3661 electro-pneumatic positioner:**  
Meets EN 61326-1:2013

Immunity—Industrial locations per Table 2 of the EN 61326-1 standard. Performance is shown in table 1 below.

Emissions—Class A

ISM equipment rating: Group 1, Class A

### Positioner Adjustments

**Span:** Adjustable from 19 mm to 50 mm (0.75 to 2 inches) stem travel

**Zero:** 0 to 100%

**Gain:** 0.5 to 6% PB (proportional band)<sup>(3)</sup>

**Output Volume Damping:** Loop dynamic response adjustment

### Delivery Capacity<sup>(4)</sup>:

**1.4 Bar (20 Psig) Supply:** 4.3 normal m<sup>3</sup>/hour (150 scfh)

**2.4 Bar (35 Psig) Supply:** 6.6 normal m<sup>3</sup>/hour (230 scfh)

### Exhaust Capacity<sup>(4)</sup>:

**1.4 Bar (20 Psig) Supply:** 4.8 normal m<sup>3</sup>/hour (170 scfh)

**2.4 Bar (35 Psig) Supply:** 7.4 normal m<sup>3</sup>/hour (260 scfh)

### Steady-State Air Consumption<sup>(4,5)</sup>

**3660:** 0.17 normal m<sup>3</sup>/hour (6.0 scfh) at 1.4 bar (20 psig) supply pressure.

0.22 normal m<sup>3</sup>/hour (7.9 scfh) at 2.4 bar (35 psig) supply pressure

**3661:** 0.24 normal m<sup>3</sup>/hour (8.8 scfh) at 1.4 bar (20 psig) supply pressure. 0.33 normal m<sup>3</sup>/hour (12.3 scfh) at 2.4 bar (35 psig) supply pressure

### Operating Influences

**Supply Pressure:** 69 mbar (1 psig) change in supply pressure changes the actuator stem position less than 0.16%<sup>(6)</sup> of the travel

### Operative Temperature Limits<sup>(1)</sup>

-40 to 82°C (-40 to 180°F)

### Hazardous Area Classification for 3660

3660 pneumatic positioners comply with the requirements of ATEX Group II Category 2 Gas and Dust

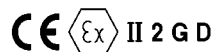

3660 pneumatic positioners meet Customs Union technical regulation TP TC 012/2011 for Groups II/III Category 2 equipment

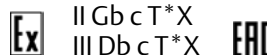

## Specifications (continued)

### Hazardous Area Classification for 3661

CSA & FM—Intrinsically Safe, Type n, Non-incendive

ATEX & IECEx—Intrinsically Safe, Type n  
(Gas Atmospheres Only)

### Housing Classification for 3661

CSA—Type 3 Encl.

FM—NEMA 3, IP54

ATEX & IECEx—IP44

Mounting orientation requires vent location to be below horizontal

### Other Classifications/Certifications for 3661

CUTR— Customs Union Technical Regulations (Russia, Kazakhstan, Belarus, and Armenia)

INMETRO— National Institute of Metrology, Quality, and Technology (Brazil)

KGS—Korea Gas Safety Corporation (South Korea)

Contact your [Emerson sales office](#) or Local Business Partner for classification/certification specific information

### Mounting

The positioner can be mounted in one of four different configurations. See figure 1.

### Pressure Connections

1/4 NPT internal

### Conduit Connection for 3661

1/2 NPT (M20 or PG13 adaptors optional)

### Vent Connection

1/4 NPT internal

### Maximum Valve Stem Travel

50 mm (2 inch); adjustable to obtain lesser travel with standard input signal—minimum 19 mm (0.75 inch)

### Construction Materials

See table 4

### Approximate Weight

3660: 2.6 pounds (1.2 kg)

3661: 3.0 pounds (1.4 kg)

### Options

3660:

- Instrument and output pressure gauges,
- Integrally mounted bypass valve

3661: Output pressure gauge

3660 and 3661: Connectors for diagnostic testing

- stainless steel or ■ brass

NOTE: Specialized instrument terms are defined in ANSI/ISA Standard 51.1 - Process Instrument Terminology.

1. The pressure/temperature limits in this bulletin and any applicable standard or code limitation should not be exceeded.

2. Hysteresis value at a gain setting of 1/2 turn.

3. Adjusting the gain (PB) adjustment will change the nozzle flapper relationship. This nozzle flapper change affects the actuator/positioner response time.

4. Normal m<sup>3</sup>/hr—normal cubic meters per hour (0°C and 1.01325 bar absolute). Scfh—standard cubic feet per hour (60°F and 14.7 psia).

5. Air consumption at a gain setting of 1/2 turn.

6. At supply pressure of 2.4 bar (35 psig).

**Table 1. Fisher 3661 Electro-Pneumatic Positioner EMC Summary Results—Immunity**

Port	Phenomenon	Basic Standard	Test Level	Performance Criteria <sup>(1)</sup>
Enclosure	Electrostatic discharge (ESD)	IEC 61000-4-2	4 kV contact 8 kV air	A
	Radiated EM field	IEC 61000-4-3	80 to 1000 MHz @ 10V/m with 1 kHz AM at 80% 1400 to 2000 MHz @ 3V/m with 1 kHz AM at 80% 2000 to 2700 MHz @ 1V/m with 1 kHz AM at 80%	A
	Rated power frequency magnetic field	IEC 61000-4-8	60 A/m at 50 Hz	A
I/O signal/control	Burst	IEC 61000-4-4	1 kV	A
	Surge	IEC 61000-4-5	1 kV (line to ground only, each)	B
	Conducted RF	IEC 61000-4-6	150 kHz to 80 MHz at 3 Vrms	A
Specification limit = ±1% of span 1. A = No degradation during testing. B = Temporary degradation during testing, but is self-recovering.				

Figure 1. Mounting Configurations (see table 3 for Positioner Action and Signals)

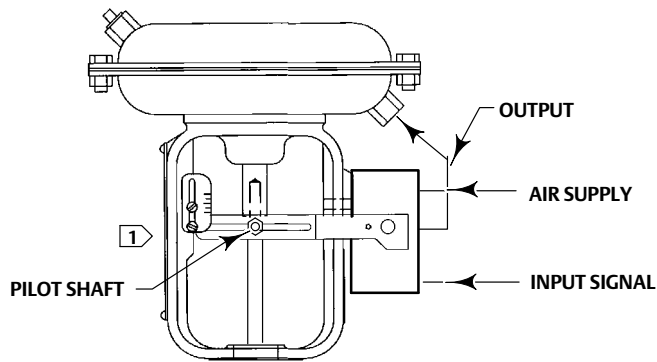

**ACTUATOR: AIR-TO-RETRACT  
POSITIONER ACTION: DIRECT  
(INCREASING INPUT SIGNAL INCREASES  
OUTPUT PRESSURE TO ACTUATOR)**

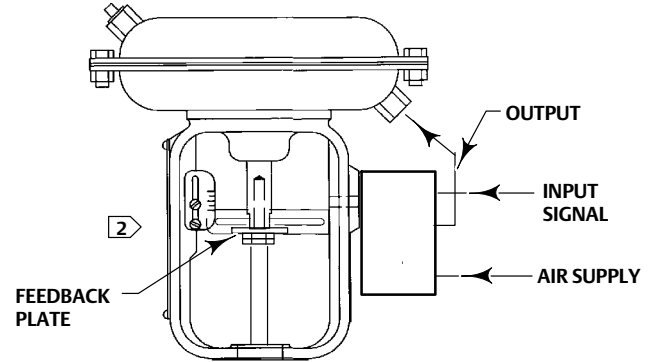

**ACTUATOR: AIR-TO-RETRACT  
POSITIONER ACTION: REVERSE  
(INCREASING INPUT SIGNAL DECREASES  
OUTPUT PRESSURE TO ACTUATOR)**

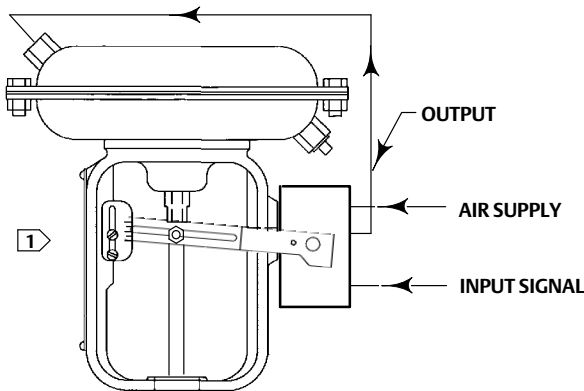

**ACTUATOR: AIR-TO-EXTEND  
POSITIONER ACTION: REVERSE  
(INCREASING INPUT SIGNAL DECREASES  
OUTPUT PRESSURE TO ACTUATOR)**

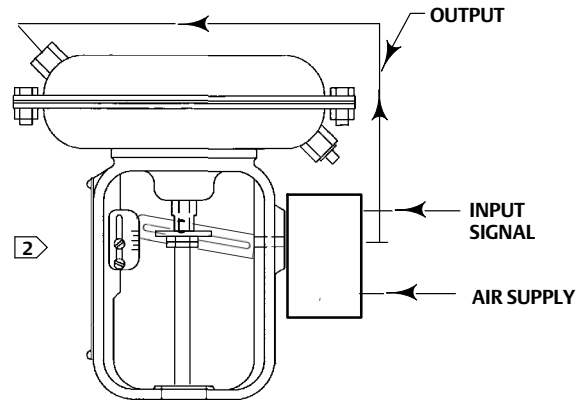

**ACTUATOR: AIR-TO-EXTEND  
POSITIONER ACTION: DIRECT  
(INCREASING INPUT SIGNAL INCREASES  
OUTPUT PRESSURE TO ACTUATOR)**

**Notes:**

- ① When mounting on Baumann actuators, install feedback plate so lip is up. Install feedback lever arm assembly so pilot shaft is on top of the feedback plate.
- ② When mounting on Baumann actuators, install feedback plate so lip is down. Install feedback lever arm assembly so pilot shaft is underneath the feedback plate.

1789106-B  
1789105-B  
3880195-B  
A4035-2

**Table 2. Standard and Split Range Capabilities**

POSITIONER	3660		3660		3661
	0.2 to 1.0 bar (3 to 15 Psig) Input Signal		0.4 to 2.0 bar (6 to 30 Psig) Input Signal		
	Bar	Psig	Psig	Bar	
One Way 1:1	0.2 to 1.0	3 to 15	6 to 30	0.4 to 2.0	4 to 20
Two Way 2:1	0.2 to 0.6 0.6 to 1.0	3 to 9 9 to 15	6 to 18 18 to 30	0.4 to 1.2 1.2 to 2.0	4 to 12 12 to 20
Three Way 3:1	0.2 to 0.5 0.5 to 0.8 0.8 to 1.0	3 to 7 7 to 11 11 to 15	6 to 14 14 to 22 22 to 30	0.4 to 1.0 1.0 to 1.6 1.6 to 2.0	4 to 9.33 9.33 to 14.66 14.66 to 20
Four Way 4:1	0.2 to 0.4 0.4 to 0.6 0.6 to 0.8 0.8 to 1.0	3 to 6 6 to 9 9 to 12 12 to 15	6 to 12 12 to 18 18 to 24 24 to 30	0.4 to 0.8 0.8 to 1.2 1.2 to 1.6 1.6 to 2.0	4 to 8 8 to 12 12 to 16 16 to 20

**Table 3. Positioner Input Signal, Action, and Output Signal**

Input Signal	Positioner Output
Direct 0.2 to 1.0 bar (3 to 15 psig) 0.4 to 2.0 bar (6 to 30 psig) 4 to 20 mA	Up to 6.2 bar (90 psig)
Reverse 1.0 to 0.2 bar (15 to 3 psig) 2.0 to 0.4 bar (30 to 6 psig) 20 to 4 mA	
For split range signal refer to table 2	

**Table 4. Construction Materials**

PART	MATERIAL	
	Standard	Optional
Case and Cover	Aluminum	---
Feedback Lever Assembly	Stainless Steel	---
Range Spring	N09902	---
Input Module Diaphragm Relay Gasket O-Ring	Nitrile Nitrile Silicone Rubber Ethylene/Propylene	---
Nozzle	Aluminum	---
Flapper	Aluminum	---
Relay Metal Parts	Aluminum and Stainless Steel	---
Gauges	Brass and Plastic	---
All Fasteners	Stainless Steel	
Exterior Tubing and Fitting	Copper/Brass	Stainless Steel
Connectors for Diagnostic Testing	Stainless Steel or Brass	---

# Principle of Operation

Refer to figure 2 for operational schematic.

The instrument pressure acts on the input module, which controls the flapper-nozzle system of the relay. Supply pressure is applied to the relay, and the output pressure of the relay is supplied to the control valve actuator.

For a direct-acting positioner, increases in instrument pressure causes the input module to pivot the beam. The beam pivots the flapper and restricts the nozzle. The nozzle pressure increases and causes the relay assembly to increase output pressure to the actuator. With a direct-acting actuator, this increased pressure moves the actuator stem downward. Stem movement is fed back to the beam by means of a feedback lever and range spring, which cause the flapper to pivot slightly away from the nozzle to prevent any further increases in relay output pressure. The positioner is

once again in equilibrium but at a higher instrument pressure, a slightly different flapper position, and a new actuator stem position.

A decrease in instrument pressure decreases nozzle pressure, which allows the relay to bleed off actuator loading pressure.

Operation of a reverse-acting positioner is similar except that the flapper position is reversed from that shown in figure 2. The reversed position uses the alternate flapper pivot point so that increases in instrument pressure rotate the flapper away from the nozzle to reduce nozzle pressure.

With a 3661 electro-pneumatic positioner, the electro-pneumatic converter provides a 0.2 to 1.0 bar (3 to 15 psig) output pressure proportional to the 4-20 mA input signal. The 0.2 to 1.0 bar (3 to 15 psig) output pressure becomes the input signal pressure to the input module.

Figure 2. Operational Schematic

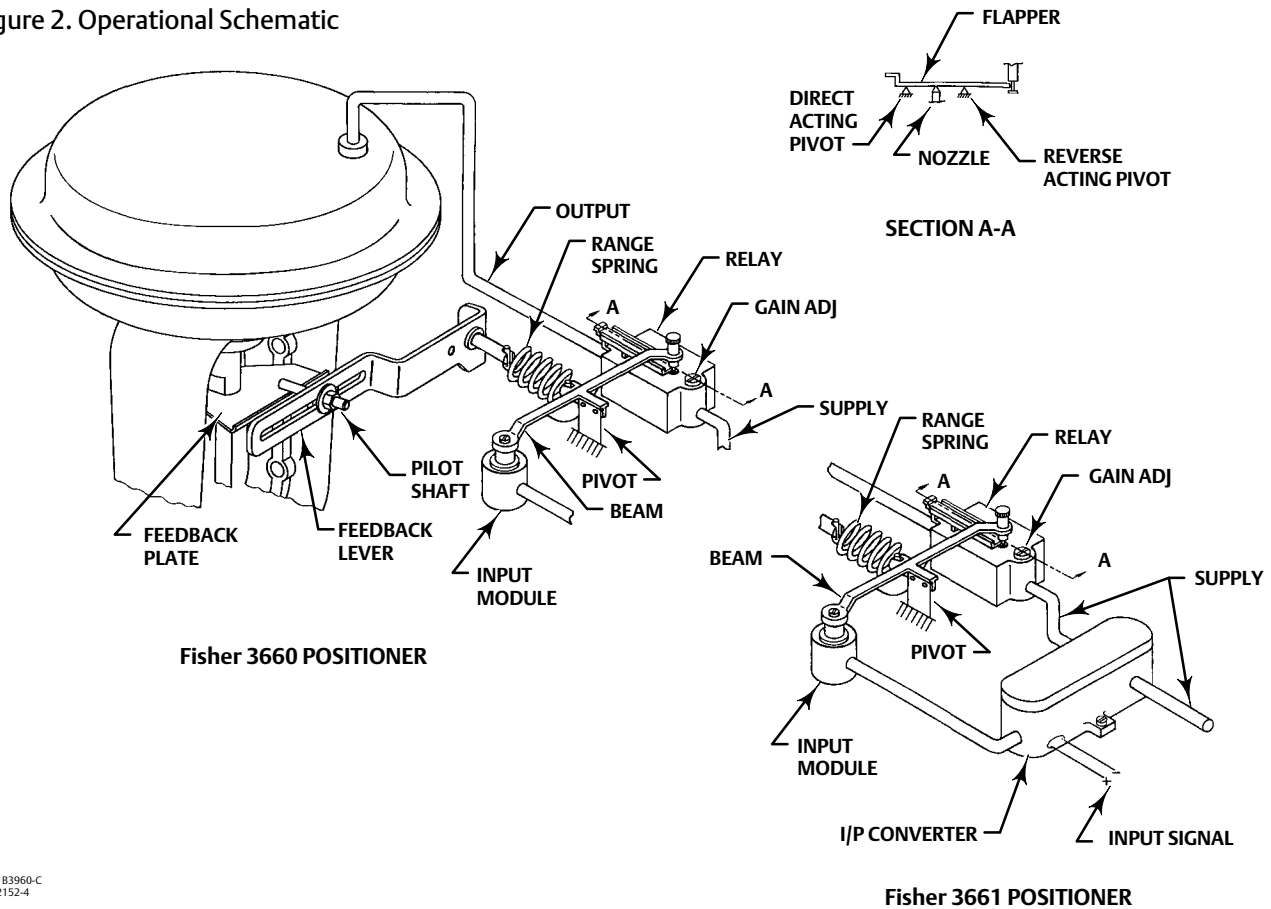

3183960-C  
B2152-4

**Product Bulletin**

62.1:3660  
August 2018

**3660 and 3661 Positioners**

D101407X012

Figure 3. Positioner Dimensions and Connections (see table 5 for the X dimension)

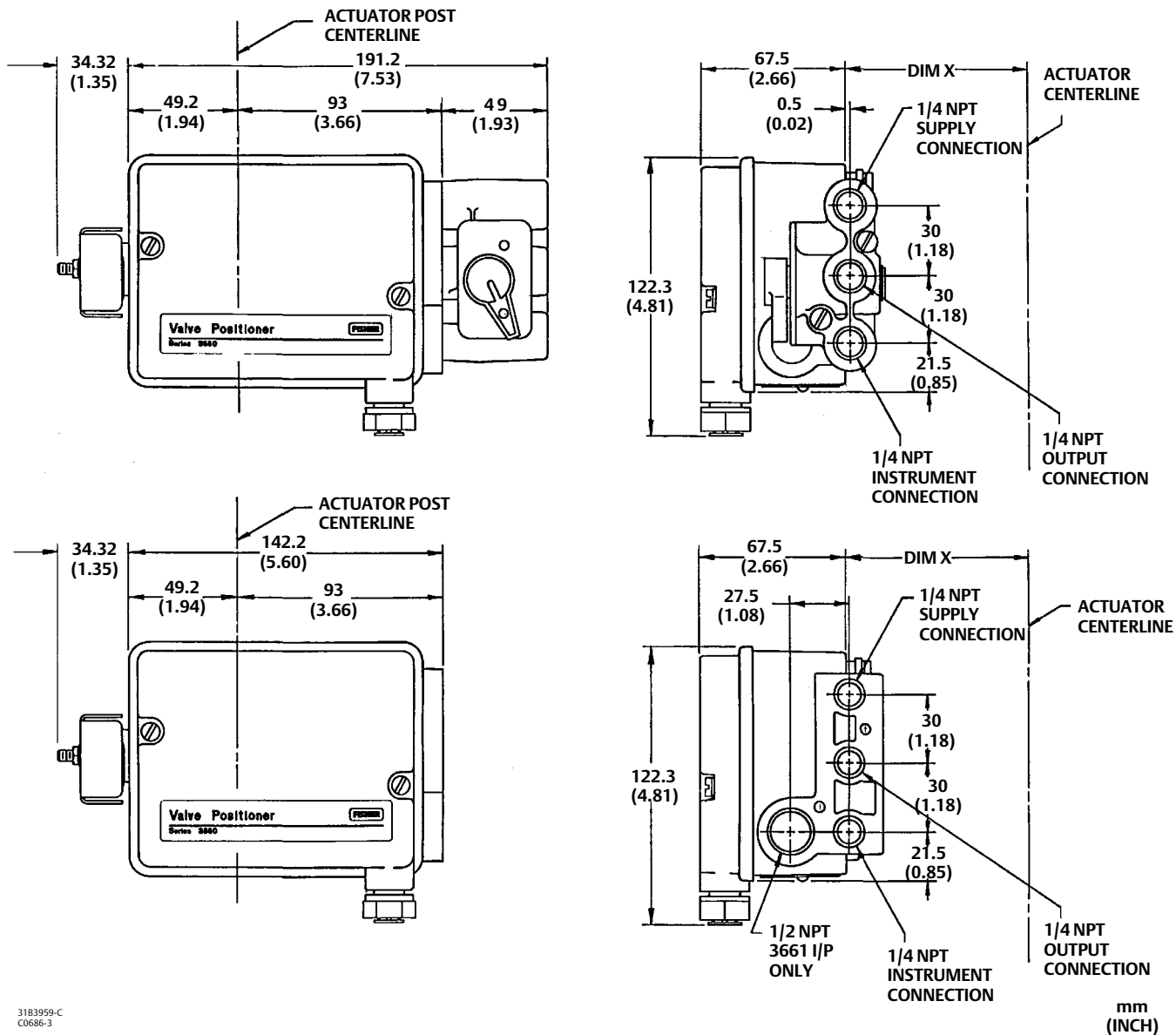

3183959-C  
C0686-3

mm  
(INCH)



Table 5. Dimension X for figure 3

ACTUATOR CENTERLINE TO POSITIONER			
Type	Size	X	
		mm	Inch
657/667	30	92.2	3.63
	34	95.3	3.75
	40	104.9	4.13
	45/46	108.0	4.25
	50/60	128.5	5.06
	30i	121.5	4.78
	34i	123.2 / 121.5	4.85 / 4.78
	40i	129.5	5.10
	45i/46i	129.5 / 134.9	5.10 / 5.31
	50i/60i	144.5	5.69
1250	225	86.0	3.39
	450	86.0	3.39
	675	110.0	4.33
3024S	1.21	83.5	3.29
	1.31	87.5	3.44
	1.41	87.5	3.44
Baumann	16in <sup>2</sup>	53.8	2.12
	32in <sup>2</sup>	71.4	2.81
	54in <sup>2</sup>	71.4	2.81
	70in <sup>2</sup>	71.4	2.81
GX	225	81.0	3.19
	750	81.0	3.19
	1200	81.0	3.19

## Installation

The supply pressure medium should be clean, dry, filtered air. If the supply source is capable of exceeding the maximum actuator operating pressure or positioner supply pressure, appropriate steps must be taken during installation to protect the positioner and all connected equipment against overpressure.

Overall dimensions and connections are shown in figure 3 and table 5.

## Ordering Information

### Application

When ordering, specify:

1. Type number
2. Input signal range: pneumatic or milliampere
3. Maximum supply pressure available
4. Valve plug travel: actuator type and size
5. Stroking time requirements, if critical
6. Ambient temperature range
7. Direct or reverse acting
8. Supply pressure regulator, gauges, and bypass, if required
9. Hazardous area classification (3661)
10. Connectors for diagnostic testing, if required

Figure 4. FlowScanner Diagnostic System Connections

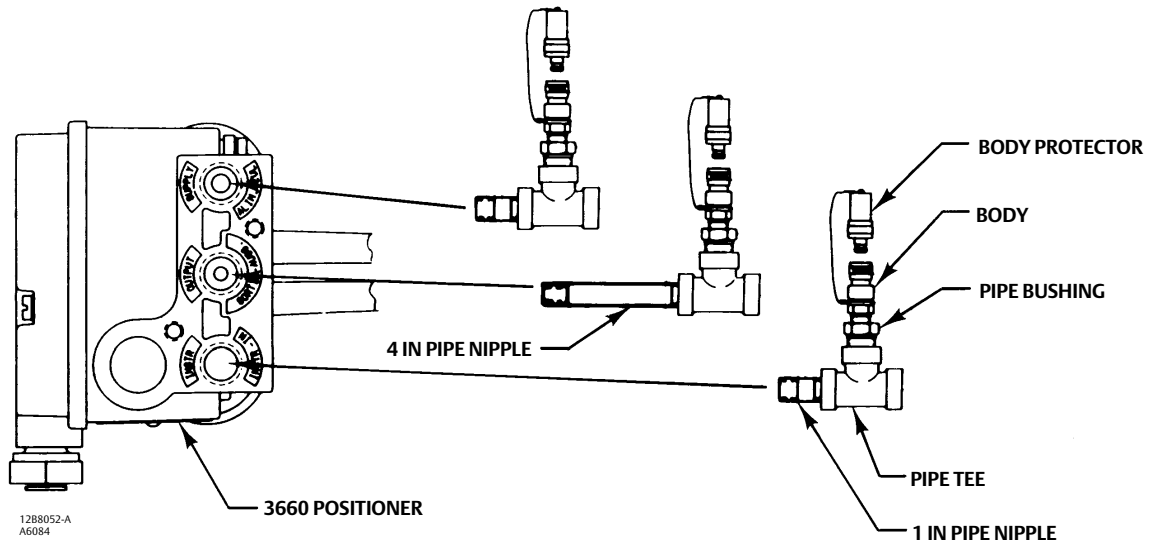

Fisher 3660 POSITIONER

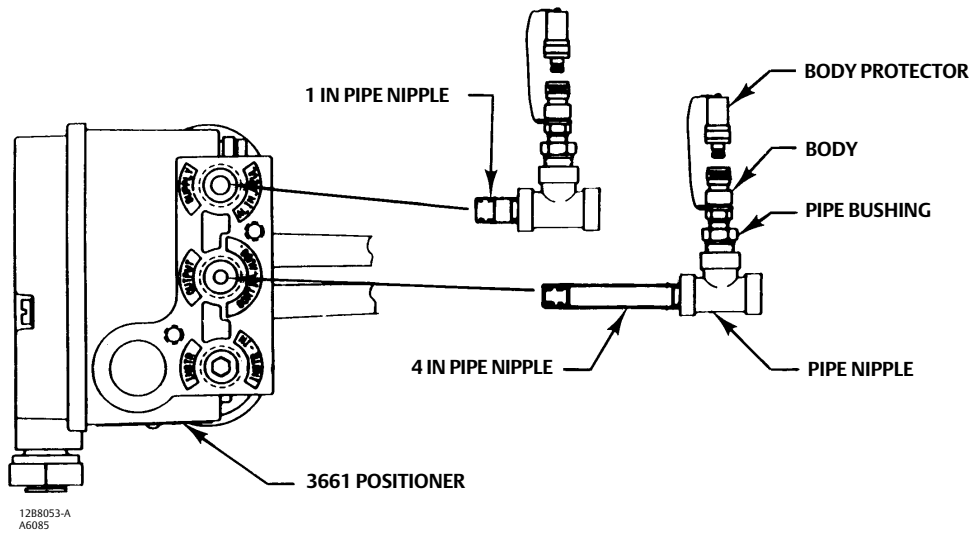

Fisher 3661 POSITIONER



Neither Emerson, Emerson Automation Solutions, nor any of their affiliated entities assumes responsibility for the selection, use or maintenance of any product. Responsibility for proper selection, use, and maintenance of any product remains solely with the purchaser and end user.

Fisher, Baumann, and FlowScanner are marks owned by one of the companies in the Emerson Automation Solutions business unit of Emerson Electric Co. Emerson Automation Solutions, Emerson, and the Emerson logo are trademarks and service marks of Emerson Electric Co. All other marks are the property of their respective owners.

The contents of this publication are presented for informational purposes only, and while every effort has been made to ensure their accuracy, they are not to be construed as warranties or guarantees, express or implied, regarding the products or services described herein or their use or applicability. All sales are governed by our terms and conditions, which are available upon request. We reserve the right to modify or improve the designs or specifications of such products at any time without notice.

Emerson Automation Solutions  
Marshalltown, Iowa 50158 USA  
Sorocaba, 18087 Brazil  
Cernay, 68700 France  
Dubai, United Arab Emirates  
Singapore 128461 Singapore

[www.Fisher.com](http://www.Fisher.com)

