

NEC® 2014 CODE REVIEW



A GUIDE FOR USE OF ELECTRICAL PRODUCTS IN HAZARDOUS LOCATIONS



TABLE OF CONTENTS

INTRODUCTION AND GENERAL INFORMATION

Purpose of the Review	1
Code Excerpts/Notations	1
Technical Help Available	3
Disclaimer	3
Permissions	3
Trade Sizes	3
Most Appleton Products Designed for Hazardous Locations are Suitable for All Classes	3
Appleton Products Meet or Exceed Authorized Standards	3
Introduction	4
Appleton® Registered Trademarks; Metric Designator and Trade Size	5
Types of Explosionproof Construction (Appleton Products)	6-7

NEC® ARTICLES 500 THROUGH 516 – TEXT AND COMMENTARY

Article 500 – Hazardous (Classified) Locations, Class I, II, and III, Divisions 1 and 2	
Changes to Article 500	9
500.1 Scope — Articles 500 Through 504	9
500.2 Definitions	9
500.3 Other Articles	10
500.4 General	10
500.5 Classifications of Locations	11
500.6 Material Groups	13
500.7 Protection Techniques	15
500.8 Equipment	16
500.9 Specific Occupancies	20
Article 501 – Class I Locations	
Changes to Article 501	21
501.1 Scope	21
501.5 Zone Equipment	21
501.10 Wiring Methods	22
501.15 Sealing and Drainage	25
501.17 Process Sealing	31
501.20 Conductor Insulation, Class I, Divisions 1 and 2	32
501.25 Uninsulated Exposed Parts, Class I, Divisions 1 and 2	32
501.30 Grounding and Bonding, Class I, Divisions 1 and 2	32
501.35 Surge Protection	32
501.100 Transformers and Capacitors	34
501.105 Meters, Instruments, and Relays	34
501.115 Switches, Circuit Breakers, Motor Controllers, and Fuses	35
501.120 Control Transformers and Resistors	36
501.125 Motors and Generators	37
501.130 Luminaires	38
501.135 Utilization Equipment	41
501.140 Flexible Cords, Class I, Divisions 1 and 2	42
501.145 Receptacles and Attachment Plugs, Class I, Divisions 1 and 2	43
501.150 Signaling, Alarm, Remote-Control, and Communications Systems	43

TABLE OF CONTENTS

Article 502 – Class II Locations	
Changes to Article 502	45
502.1 Scope	45
502.5 Explosionproof Equipment	45
502.6 Zone Equipment	45
502.10 Wiring Methods	47
502.15 Sealing, Class II, Divisions 1 and 2	48
502.25 Uninsulated Exposed Parts, Class II, Divisions 1 and 2	48
502.30 Grounding and Bonding, Class II, Divisions 1 and 2	49
502.35 Surge Protection — Class II, Divisions 1 and 2	49
502.100 Transformers and Capacitors	49
502.115 Switches, Circuit Breakers, Motor Controllers, and Fuses	50
502.120 Control Transformers and Resistors	50
502.125 Motors and Generators	51
502.128 Ventilating Piping	52
502.130 Luminaires	53
502.135 Utilization Equipment	53
502.140 Flexible Cords — Class II, Divisions 1 and 2	54
502.145 Receptacles and Attachment Plugs	54
502.150 Signaling, Alarm, Remote-Control, and Communications Systems; and Meters, Instruments, and Relays	54
Article 503 – Class III Locations	
Changes to Article 503	57
503.1 Scope	57
503.5 General	57
503.6 Zone Equipment	58
503.10 Wiring Methods	58
503.25 Uninsulated Exposed Parts, Class III, Divisions 1 and 2	59
503.30 Grounding and Bonding — Class III, Divisions 1 and 2	59
503.100 Transformers and Capacitors — Class III, Divisions 1 and 2	59
503.115 Switches, Circuit Breakers, Motor Controllers, and Fuses — Class III, Divisions 1 and 2	59
503.120 Control Transformers and Resistors — Class III, Divisions 1 and 2	59
503.125 Motors and Generators — Class III, Divisions 1 and 2	59
503.128 Ventilating Piping — Class III, Divisions 1 and 2	60
503.130 Luminaires — Class III, Divisions 1 and 2	60
503.135 Utilization Equipment — Class III, Divisions 1 and 2	60
503.140 Flexible Cords — Class III, Divisions 1 and 2	61
503.145 Receptacles and Attachment Plugs — Class III, Divisions 1 and 2	61
503.150 Signaling, Alarm, Remote-Control, and Local Loudspeaker Intercommunications Systems — Class III, Divisions 1 and 2	61
503.155 Electric Cranes, Hoists, and Similar Equipment — Class III, Divisions 1 and 2	61
503.160 Storage Battery Charging Equipment — Class III, Divisions 1 and 2	62
Article 504 – Intrinsically Safe Systems	
Changes to Article 504	63
504.1 Scope	63
504.2 Definitions	63
504.3 Application of Other Articles	64
504.4 Equipment	64
504.10 Equipment Installation	64

TABLE OF CONTENTS

504.20 Wiring Methods	64
504.30 Separation of Intrinsically Safe Conductors	65
504.50 Grounding	65
504.60 Bonding	66
504.70 Sealing	66
504.80 Identification	66
Article 505 – Zone 0, 1, and 2 Locations	
Changes to Article 505	67
505.1 Scope	67
505.2 Definitions	68
505.3 Other Articles	69
505.4 General	69
505.5 Classifications of Locations	69
505.6 Material Groups	70
505.7 Special Precaution	71
505.8 Protection Techniques	72
505.9 Equipment	73
505.15 Wiring Methods	76
505.16 Sealing and Drainage	78
505.17 Flexible Cords and Connections	81
505.18 Conductors and Conductor Insulation	81
505.19 Uninsulated Exposed Parts	81
505.20 Equipment Requirements	81
505.22 Increased Safety “e” Motors and Generators	82
505.25 Grounding and Bonding	82
505.26 Process Sealing	83
Article 506 – Zone 20, 21, and 22 Locations for Combustible Dusts or Ignitable Fibers/Flyings	
Changes to Article 506	85
506.1 Scope	85
506.2 Definitions	85
506.3 Other Articles	87
506.4 General	87
506.5 Classification of Locations	87
506.6 Material Groups	88
506.7 Special Precaution	88
506.8 Protection Techniques	88
506.9 Equipment Requirements	89
506.15 Wiring Methods	91
506.16 Sealing	92
506.17 Flexible Cords	92
506.20 Equipment Installation	93
506.25 Grounding and Bonding	93
Article 510 – Hazardous (Classified) Locations – Specific	
Changes to Article 510	95
510.1 Scope	95
510.2 General	95

TABLE OF CONTENTS

Article 511 – Commercial Garages, Repair and Storage	
Changes to Article 511	97
511.1 Scope	97
511.2 Definitions	97
511.3 Area Classification, General	97
511.4 Wiring and Equipment in Class I Locations	98
511.7 Wiring and Equipment Installed Above Class I Locations	98
511.9 Sealing	98
511.10 Special Equipment	98
511.12 Ground-Fault Circuit-Interrupter Protection for Personnel	100
511.16 Grounding and Bonding Requirements	100
Article 513 – Aircraft Hangers	
Changes to Article 513	101
513.1 Scope	101
513.2 Definitions	101
513.3 Classification of Locations	102
513.4 Wiring and Equipment in Class I Locations	102
513.7 Wiring and Equipment Not Installed in Class I Locations	102
513.8 Underground Wiring	103
513.9 Sealing	103
513.10 Special Equipment	103
513.12 Ground-Fault Circuit-Interrupter Protection for Personnel	104
513.16 Grounding and Bonding Requirements	104
Article 514 – Motor Fuel Dispensing Facilities	
Changes to Article 514	105
514.1 Scope	105
514.2 Definition	105
514.3 Classification of Locations	105
514.4 Wiring and Equipment Installed in Class I Locations	109
514.7 Wiring and Equipment Above Class I Locations	109
514.8 Underground Wiring	109
514.9 Sealing	109
514.11 Circuit Disconnects	110
514.13 Provisions for Maintenance and Service of Dispensing Equipment	110
514.16 Grounding and Bonding	110
Article 515 – Bulk Storage Plants	
Changes to Article 515	111
515.1 Scope	111
515.3 Class I Locations	111
515.4 Wiring and Equipment Located in Class I Locations	111
515.7 Wiring and Equipment Above Class I Locations	111
515.8 Underground Wiring	111
515.9 Sealing	112
515.10 Special Equipment — Gasoline Dispensers	112
515.16 Grounding and Bonding	112

TABLE OF CONTENTS

Article 516 – Spray Application, Dipping, Coating, and Printing Processes Using Flammable or Combustible Materials	
Changes to Article 516	117
516.1 Scope	117
516.2 Definitions	117
516.3 Classification of Locations	117
516.4 Wiring and Equipment in Class I Locations	121
516.7 Wiring and Equipment Not Within Classified Locations	124
516.10 Special Equipment	124
516.16 Grounding	126
APPENDIXES	
Appendix A-1: Class I Flammable Gases And Vapors	127-132
Appendix A-2: Class II Combustible Dusts	133-136
Appendix B-1: Applicable Product Standards	137-138
Appendix B-2: NEMA Enclosure Definitions	139
Appendix B-3: Comparison Between NEMA Enclosure Type Numbers and IEC Enclosure Classification Designations	140-141
Appendix C: Standards, Testing and Certification	142-143
Appendix D: Quick Selection Guide — Equipment for Hazardous Locations	144-147
Appendix E-1: Lighting and Power Diagrams: Class I, Divisions 1 and 2, Group B; Class I, Zones 1 and 2, Groups IIA, IIB + H ₂	148-149
Appendix E-2: Power Diagram: Class I, Division 1, Groups C and D, Class I, Zone 1, Groups IIA, IIB	150-151
Appendix E-3: Lighting Diagram: Class I, Division 1, Groups C and D; Class I, Zone 1, Groups IIA and IIB	152-153
Appendix E-4: Lighting and Power Diagram: Class I, Division 2, Groups C and D; Class I, Zone 2, Groups IIA and IIB	154-155
Appendix E-5: Power Diagram: Class II, Divisions 1 and 2, Groups E, F and G; Class II, Zones 21 and 22	156-157
Appendix E-6: Lighting Diagram: Class II, Divisions 1 and 2, Groups E, F and G; Class II, Zones 21 and 22	158-159
Appendix E-7: Lighting and Power Diagram: Class I, Zone 1; Class I, Zone 2	160-161
Appendix F: Glossary of Definitions	162

NOTES:

INTRODUCTION AND GENERAL INFORMATION



PURPOSE OF THE REVIEW

- Assist in interpreting the requirements of Articles 500-516 of the 2014 *NEC*®
- To provide information that will assist in minimizing the fire and explosive hazards encountered in classified locations, including references to sources where more detailed information can be obtained.
- To acquaint the reader with the various types of electrical equipment, and equipment design, used in hazardous locations.
- To provide a guide for the correct selection and installation of electrical products in hazardous (classified) locations, in conformance with the *National Electrical Code*®.

CODE EXCERPTS/NOTATIONS

- *NEC*® Articles 500 thru 516 indicated with blue text. For the 2014 Appleton® Code Review, the commentary text, where practical, has been located directly following the published *NEC*® rule.
- Commentaries on *NEC*® presented in black text.
- Underlined text indicates change from previous *NEC*® edition.

Material that is extracted from another standard has not been compromised or violated. Any editing of the extracted text is consistent with that of the *NEC*®.

Appendix A contains tables of flash points for common hazardous gases as well as information on ignition temperatures for hazardous dusts.

Appendix B contains an informative list of associated installation standards for electrical equipment with which Appleton products are designed, tested, and manufactured to comply. This appendix also includes the NEMA Enclosure Type definitions and a practical conversion chart that can be used to convert a NEMA Enclosure Type to an IEC IP Classification.

Appendix C contains an informative list of electrical and fire safety organizations.

Appendix D contains an informative quick selection guide of Appleton products for each type of hazardous location.

Appendix E contains clarifying diagrams of typical Appleton hazardous location product installations.

Appendix F contains a descriptive glossary of definitions.

NOTES:

INTRODUCTION AND GENERAL INFORMATION

TECHNICAL HELP AVAILABLE

The information presented in this booklet provides extensive help in determining *NEC*[®] requirements for the use of electrical products in hazardous locations. However, even though every attempt has been made to provide complete data, questions inevitably arise. In these circumstances, contact your local Appleton[®] representative for technical assistance. In addition, Appleton's staff of technical experts is at your service.

The *NEC*[®] and other NFPA[®] Standards are international standards. All measurements in the 2014 *NEC*[®] are shown in SI metric units, followed by the inch-pound value in parenthesis. For example, 1.6 mm (1/16 in.).

A soft metric conversion is when the dimensions of a product already designed and manufactured to the English or Imperial inch-pound system have their dimensions converted to metric dimensions. The product does not change.

A hard metric measurement is where a product has been designed to SI metric dimensions. No conversion from English or Imperial inch-pound measurement units is involved.

A hard conversion is where an existing product is redesigned into a new size. For example, if a dimension is required to be 10 feet, it is shown in the *NEC*[®] as 3.0 m (10 ft.). Where rounding off would create a safety hazard, the metric conversions are mathematically identical. Note that the 10 feet remains the same, and the metric value of 3.03 m appears and has not been rounded off to 3.0 m.

DISCLAIMER

The information presented in this booklet has been assembled from various sources. Although every attempt has been made to ensure accuracy, neither Appleton Grp LLC nor its contributors to this publication assumes responsibility for any inaccuracies or omissions in the data presented. As a safety precaution, information to be utilized from this booklet should be verified from the 2014 *National Electrical Code*[®] and other sources.

PERMISSIONS

Reprinted with permission from NFPA 70[®] - 2014, *National Electrical Code*[®], Copyright © 2013, National Fire Protection Association, Quincy, MA. This material is not the official position of the NFPA on the referenced subject, which is represented only by the standard in its entirety. Association Such permission does not imply an endorsement by the NFPA[®] of Appleton Group equipment shown in this booklet. NFPA[®] does not endorse any product. NFPA 70[®], the title *National Electrical Code*[®] and the acronym *NEC*[®] are registered trademarks of the National Fire Protection.

TRADE SIZES

The electrical industry has been incorrectly referring to raceways in inches for many years. Raceway sizes have always been an approximation. For example, there has never been a ½ inch raceway! The *NEC*[®] in Section 90.9(C)(1) states that "where the actual measured size of a product is not the same as the nominal size, trade size designators shall be used rather than dimensions." To alleviate potential confusion, this text uses only the term trade size when referring to conduit and tubing sizes.

MOST APPLETON PRODUCTS DESIGNED FOR HAZARDOUS LOCATIONS ARE SUITABLE FOR ALL CLASSES

Many Appleton[®] electrical products approved for Class I, Division 1 and 2, are also suitable for Class II, Division 1 and 2, and for Class III, Division 1 and 2. A glance through the Appleton Master Catalog will confirm this information. All Appleton[®] products intended for use in Class I locations are designed to conform to the requirements in *NEC*[®] Sections 500.5(B)(1) and (2), and enumerated in Section 500.7(A) for "Explosionproof Equipment" as defined in Article 100. Products designed for Class II locations conform to the requirements stated in *NEC*[®] Sections 500.5(C)(1) and 500.5(C)(2). Products designed for Class III locations conform to the requirements of *NEC*[®] Sections 500.5(D)(1) and 500.5(D)(2).

APPLETON PRODUCTS MEET OR EXCEED AUTHORITATIVE STANDARDS

Appleton[®] Explosionproof, Flameproof, Dust-Ignitionproof, Dusttight, Nonincendive, Increased Safety, Restricted Breathing, and Nonsparking products meet or exceed the prescribed requirements of Underwriters Laboratories, Inc., and Chapter 5 of the 2014 *National Electrical Code*[®]. They provide an extra margin of safety and greater durability than the minimum specifications require.

Many other national, state, and local codes and regulations are invoked where custom-made equipment is manufactured. This Code Review is offered only as a guide to the correct and safe protection for classified products installed in hazardous location applications. State and local authorities and codes should always be consulted to properly meet all installation requirements.

INTRODUCTION AND GENERAL INFORMATION

INTRODUCTION

In order to create an explosion, three things need to be present: fuel, oxygen, and an ignition source. In addition to these three factors being present, an explosion will only occur if the mixture of the fuel with air is between its upper and lower flammable limits.

The lower flammable limit (LFL) is the minimum level of fuel that must be present, as a percentage of the total fuel/air mixture, to start and sustain combustion. At fuel levels below the minimum flammable limit, there is not enough fuel mixed with the air to support combustion.

The upper flammable limit (UFL) is the maximum level of fuel that can be present, as a percentage of the total fuel/air mixture, to start and sustain combustion. At fuel levels above the upper flammable limit, there is not enough oxygen present in the air to support combustion.

The lower explosive limit (LEL) of a fuel is sometimes referred to instead of the LFL. The only difference between the LFL and LEL, is that the LFL is reached when a flammable material mixed with air will propagate in at least one direction, and the LEL is reached when the mixture will propagate in all directions. Except for hydrogen, which has an LFL of about 4% and an LEL of around 9%, the LEL and LFL are usually pretty close to each other. Propagation of combustion in any direction is trouble, so the LFL is the number to pay attention to.

A hazardous (classified) location exists when a manufacturing, storage or handling process provides a fuel, consisting of a flammable gas, flammable liquid-produced vapors, combustible liquid-produced vapors, combustible dust, combustible flying or fiber, or some combination of these three elements; and these flammable components can be mixed with enough oxygen from the ambient air to form an explosive atmosphere between the LFL and UFL. Standards written by organizations like the National Fire Protection Association (NFPA) and the American Petroleum Institute (API) define the requirements for classification of hazardous locations.



Ignition of an explosive atmosphere can be caused either by a spark or a hot surface. Hazardous location electrical equipment needs to be specially designed and built to prevent any sparks or hot surfaces from becoming ignition sources. Protection techniques and test requirements are specified in electrical equipment standards, published by certification agencies, like Underwriters Laboratories (UL), Canadian Standards Association (CSA) and Factory Mutual (FM); and standards writing organizations such as The Instrumentation, Systems and Automation Society (ISA) and the International Electrotechnical Commission (IEC).

Even if electrical equipment is designed and built to employ protection techniques for hazardous location protection, it could cause an ignition hazard either by being improperly matched to the hazard present, or having the equipment protection technique invalidated or compromised by improper or inappropriate installation methods.

The objective of Articles 500 through 516 of the *NEC*[®] is to insure that hazardous location occupancies are properly identified and evaluated, and to make sure that electrical equipment and wiring installed and used in hazardous locations does not become an ignition source for an explosive atmosphere. This is accomplished by:

- Defining and classifying the forms and types of flammable and combustible materials that may be present;
- Requiring that hazardous (classified) locations be assessed, formally classified and documented for the degree and type of hazard that they represent;
- Recognizing different hazardous location and flammable or combustible atmosphere classification systems, and specifying how they might coexist in the same installation;
- Defining and recognizing explosion protection techniques for electrical equipment that are matched to the particular hazardous atmosphere(s) that may be present;
- Specifying electrical equipment marking and other certification documentation that must be provided by manufacturers of hazardous location electrical equipment to installers, users and inspectors;
- Providing specialized installation requirements for specific hazardous location protection techniques or occupancies;
- Providing references to standards and publications from NFPA[®] and other recognized organizations where users and inspectors can obtain more information; and
- Where necessary, requiring that specification and installation of electrical equipment in hazardous locations be done under the direction of specially qualified individuals.

INTRODUCTION AND GENERAL INFORMATION

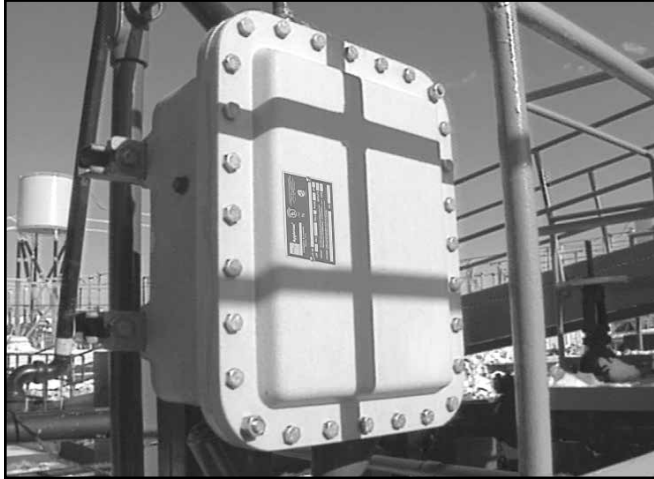

Following is a partial list of Registered Trademarks of Appleton Electric LLC that may be found in this 2014 Code Review Booklet:

A-51°
 “ST”°
 Codemaster°
 Contender°
 Division 2 Contender°
 FM8°
 Form 35°
 Intraground°
 Kwiko°
 Mercmaster°
 PowerPlex°
 Powertite°
 Reelite°
 Slide-Loc°
 Stylmaster°
 U-Line°
 UniCode°
 Unilets°
 V-51°
 Viamaster°



Metric Designator and Trade Size

Metric	Trade Size	Inches
12		3/8
16		1/2
21		3/4
27		1
35		1-1/4
41		1-1/2
53		2
63		2-1/2
78		3
91		3-1/2
103		4
129		5
155		6



TYPES OF EXPLOSIONPROOF CONSTRUCTION – APPLETON PRODUCTS

DESIGN OF EXPLOSIONPROOF EQUIPMENT

There is a rather common misconception that explosionproof equipment is gas-tight. It would be inadvisable to make an entire wiring system gas-tight. Whenever an enclosure was opened for servicing apparatus, for example, the explosive mixture could enter and be trapped in the enclosure. The trapped atmosphere could then explode the instant the apparatus was again operated. The explosion could develop pressures sufficient to burst a gas-tight enclosure and allow flames to escape into the surrounding atmosphere.

The requirement is not that enclosures be gas-tight, but that they be designed and manufactured strong enough to contain an explosion and prevent the escape of flame or heat that could ignite surrounding atmospheres. Burned gases do escape from explosionproof equipment, but their escape path has been engineered so the temperature of the escaping gas is well below its ignition point when it escapes into the surrounding atmosphere. Appleton explosionproof products are designed to withstand a hydrostatic test of four times the maximum internal explosion pressure that could be developed from a gas explosion.

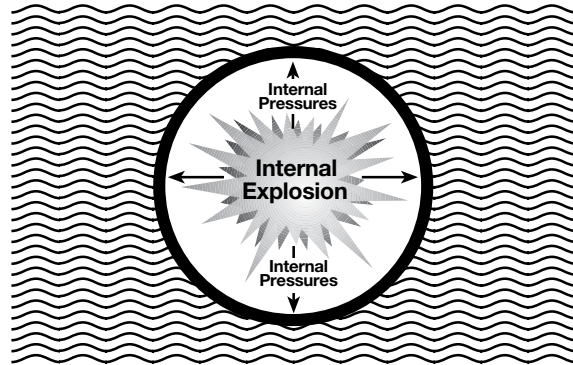

Appleton products have several different types of explosionproof construction. They are as follows:

GROUND JOINT CONSTRUCTION

Ground joint construction has two carefully machined metal surfaces which are bolted tightly together keeping the hot flaming gases caused by an explosion inside. Internal pressures force the hot gases out between the ground surfaces but are cooled in the process and therefore cannot ignite the surrounding atmosphere.

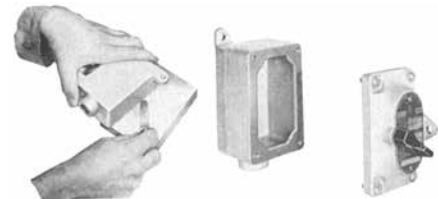
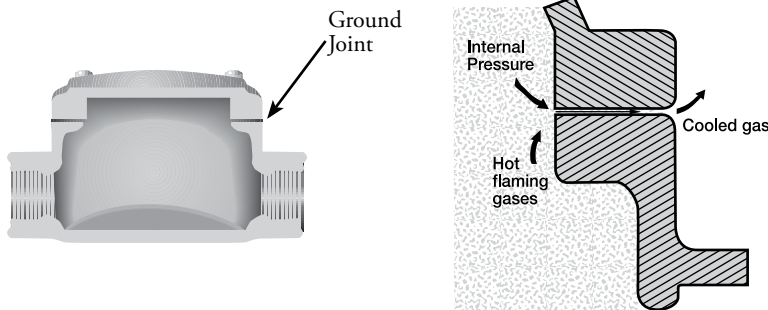

The mating surfaces of both cover and body are precision machined to meet or exceed explosionproof requirements of NEC* and UL.

THREADED JOINT CONSTRUCTION

Threaded Joint Construction is where one part of the enclosure threads into the other to form an enclosed unit. A minimum thread engagement is required, depending upon classified location Class and Group. In case of explosion, the threaded surfaces will allow the internal gas pressures to be dissipated and cooled (see illustration), but will not allow hot flaming gases to escape to the surrounding atmosphere. There has been a recent revision to the ANSI standard for Class I, Division 1 fittings and connectors. The revision addresses the minimum male NPT thread length. The minimum requirement is now what is known as the L4 thread plane. This is the same plane

that is used for conduit threading. The revision was intended to ensure that the male NPT threads of these fittings and connectors do not "bottom" prior to achieving wrenchtight make-up with female NPT threaded equipment entries of enclosures or corresponding fittings.

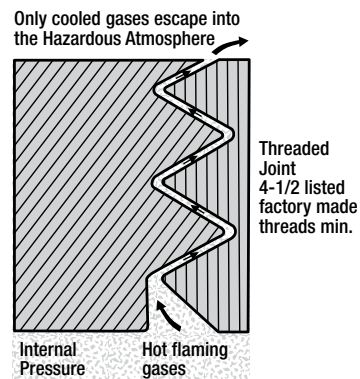
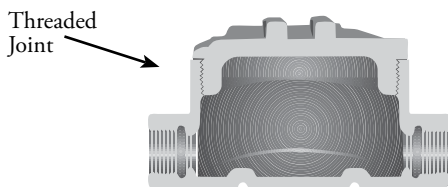

TYPES OF EXPLOSIONPROOF CONSTRUCTION – APPLETON PRODUCTS

LABYRINTH-PATH CONSTRUCTION

Labyrinth-path joint construction provides a torturous path for gases or vapors to slowly escape from the enclosure, cooling them in the process. Projections on the cover fit into corresponding recesses of the body. Hot gases or vapors begin their escape from the enclosure up the inner projection, reversing directions a total of five times before exiting at the outer projection of the enclosure. By the time the gases or vapors escape from the enclosure, they have cooled sufficiently to prevent ignition of the surrounding atmosphere.

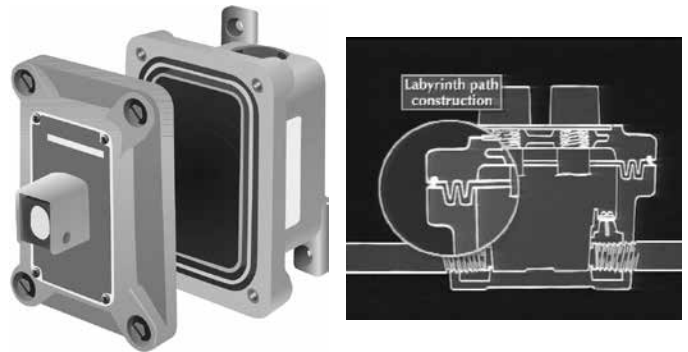

PRECISION ACME/SQUARE THREAD CONSTRUCTION

Appleton AE series threaded type enclosures have dome covers with acme screw type square threads designed to prevent seizing.

Precision acme threads provide a controlled flame path, ensuring safe operation in ignitable atmospheres. The controlled spacing of threads provides quick removal of domes.



CLOSE TOLERANCE SHAFT CONSTRUCTION

Close tolerance shaft construction is where two closely machined surfaces make contact over a prescribed distance allowing sufficient dissipation and cooling of internal pressures, but will not allow flames into the surrounding ignitable atmosphere.

This type of construction is used for shafts where threaded joint construction cannot be utilized such as in push button stations and other similar equipment.

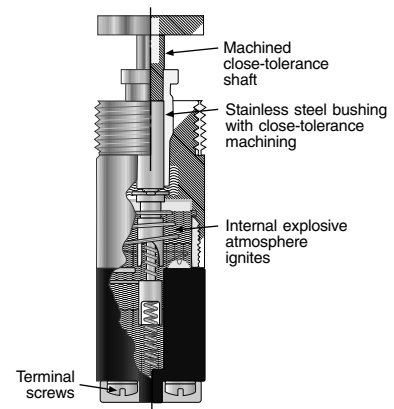

TYPICAL FACTORY SEALED PUSH BUTTON/PILOT LIGHT STATION

Appleton's explosionproof EFD Push Button stations feature an ultra-compact factory sealed, momentary contact push button assembly. Two push buttons can be mounted side-by-side on a single gang EFD cover with pilot light above. This provides a compact, start-stop-pilot, control device.



Combination Push Button and Pilot Light.

NOTES:

INTERPRETATION OF ARTICLE 500: HAZARDOUS (CLASSIFIED) LOCATIONS, CLASSES I, II, AND III, DIVISIONS 1 AND 2

CHANGES TO ARTICLE 500

The following Article 500 sections have been revised during the 2014 *NEC*® Code cycle. These changes are those that are substantive and should be noted. This list does not include those changes that are editorial in nature.

- Underlined text indicates a section that has been revised from the previous *NEC*® edition. It is not intended to indicate legislation text detailing the word-for-word revisions to the section. Where minor revisions have been made to a section, these will include underlined text for select words to indicate the minor revision.
- **Section 500.2:**
Definition, Combustible Dust
- **Section 500.5(A):**
Classification of Locations
- **Section 500.6(A) Informational Note 3:**
Material Groups, Class I Group Classification
- **Section 500.8(B)(1):**
Equipment, Approval for Class and Properties
- **Section 500.8(C)(4):**
Equipment, Marking, Equipment Temperature
- **Section 500.8(D)(1):**
Equipment, Temperature
- **Section 500.8(E)(1):**
Equipment, Threading

Informational Note: Text that is followed by a reference in brackets has been extracted from NFPA 497-2008, *Recommended Practice for the Classification of Flammable Liquids, Gases, or Vapors and of Hazardous (Classified) Locations for Electrical Installations in Chemical Process Areas*, and NFPA 499-2008, *Recommended Practice for the Classification of Combustible Dusts and of Hazardous (Classified) Locations for Electrical Installation in Chemical Process Areas*. Only editorial changes were made to the extracted text to make it consistent with this *Code*.

500.1 Scope — Articles 500 Through 504. Articles 500 through 504 cover the requirements for electrical and electronic equipment and wiring for all voltages in Class I, Divisions 1 and 2; Class II, Divisions 1 and 2; and Class III, Divisions 1 and 2 locations where fire or explosion hazards may exist due to flammable gases, flammable liquid-produced vapors, combustible liquid-produced vapors, combustible dusts, or ignitable fibers/flyings.

Informational Note No. 1: The unique hazards associated with explosives, pyrotechnics, and blasting agents are not addressed in this article.

Informational Note No. 2: For the requirements for electrical and electronic equipment and wiring for all voltages in Zone 0, Zone 1, and Zone 2 hazardous (classified) locations where fire or explosion hazards may exist due to flammable gases or vapors or flammable liquids, refer to Article 505.

Informational Note No. 3: For the requirements for electrical and electronic equipment and wiring for all voltages in Zone 20, Zone 21, and Zone 22 hazardous (classified) locations where fire or explosion hazards may exist due to combustible dusts or ignitable fibers/flyings, refer to Article 506.

500.2 Definitions. For purposes of Articles 500 through 504 and Articles 510 through 516, the following definitions apply.

The definitions in Article 500.2 are supplementary to those that appear in Article 100.

Combustible Dust. Dust particles that are 500 microns or smaller (material passing a U.S. No. 35 Standard Sieve as defined in ASTM E 11-09, Standard Specification for Wire Cloth and Sieves for Testing Purposes) and present a fire or explosion hazard when dispersed and ignited in air.

Informational Note: See ASTM E 1226-12a, *Standard Test Method for Explosibility of Dust Clouds*, or ISO 6184-1, *Explosion protection systems — Part 1: Determination of explosion indices of combustible dusts in air*, for procedures for determining the explosibility of dusts.

Revised to correlate with revisions that were adopted in the 2013 edition of NFPA 499 *Recommended Practice for the Classification of Combustible Dusts and of Hazardous (Classified) Locations for Electrical Installations in Chemical Process Areas*.

Combustible Gas Detection System. A protection technique utilizing stationary gas detectors in industrial establishments.

Control Drawing. A drawing or other document provided by the manufacturer of the intrinsically safe or associated apparatus, or of the nonincendive field wiring apparatus or associated nonincendive field wiring apparatus, that details the allowed interconnections between the intrinsically safe and associated apparatus or between the nonincendive field wiring apparatus or associated nonincendive field wiring apparatus.

More information on control drawings and their recommended content can be found in the Instrumentation, Systems, and Automation Society standard ISA RP 12.02.02 “Recommendations for the Preparation, Content, and Organization of Intrinsic Safety Control Drawings”.

Dust-Ignitionproof. Equipment enclosed in a manner that excludes dusts and does not permit arcs, sparks, or heat otherwise generated or liberated inside of the enclosure to cause ignition of exterior accumulations or atmospheric suspensions of a specified dust on or in the vicinity of the enclosure.

Informational Note: For further information on dust-ignitionproof enclosures, see Type 9 enclosure in ANSI/NEMA 250-2008, *Enclosures for Electrical Equipment*, and ANSI/UL 1203-2009, *Explosionproof and Dust-Ignitionproof Electrical Equipment for Hazardous (Classified) Locations*.

Type 9 is a broad specification. It includes equipment constructed for indoor use in hazardous (classified) locations classified as Class II, Division 1, Groups E, F, or G. Products identified as Class II, Division 1, Groups E, F, or G meet the requirements for Type 9 rated equipment.

INTERPRETATION OF ARTICLE 500: HAZARDOUS (CLASSIFIED) LOCATIONS, CLASSES I, II, AND III, DIVISIONS 1 AND 2

Dusttight. Enclosures constructed so that dust will not enter under specified test conditions.

Informational Note: See ANSI/ISA-12.12.01-2012, *Nonincendive Electrical Equipment for Use in Class I and II, Division 2, and Class III, Divisions 1 and 2 Hazardous (Classified) Locations*.

Hermetically Sealed. Equipment sealed against the entrance of an external atmosphere where the seal is made by fusion, for example, soldering, brazing, welding, or the fusion of glass to metal.

Informational Note: For further information, see ANSI/ISA-12.12.01-2012, *Nonincendive Electrical Equipment for Use in Class I and II, Division 2, and Class III, Divisions 1 and 2 Hazardous (Classified) Locations*.

Nonincendive Circuit. A circuit, other than field wiring, in which any arc or thermal effect produced under intended operating conditions of the equipment is not capable, under specified test conditions, of igniting the flammable gas-air, vapor-air, or dust-air mixture.

Informational Note: Conditions are described in ANSI/ISA-12.12.01-2012, *Nonincendive Electrical Equipment for Use in Class I and II, Division 2, and Class III, Divisions 1 and 2 Hazardous (Classified) Locations*.

Nonincendive Component. A component having contacts for making or breaking an incandive circuit and the contacting mechanism is constructed so that the component is incapable of igniting the specified flammable gas-air or vapor-air mixture. The housing of a nonincendive component is not intended to exclude the flammable atmosphere or contain an explosion.

Informational Note: For further information, see ANSI/ISA-12.12.01-2012, *Nonincendive Electrical Equipment for Use in Class I and II, Division 2, and Class III, Divisions 1 and 2 Hazardous (Classified) Locations*.

Nonincendive Equipment. Equipment having electrical/electronic circuitry that is incapable, under normal operating conditions, of causing ignition of a specified flammable gas-air, vapor-air, or dust-air mixture due to arcing or thermal means.

Informational Note: For further information, see ANSI/ISA-12.12.01-2012, *Nonincendive Electrical Equipment for Use in Class I and II, Division 2, and Class III, Divisions 1 and 2 Hazardous (Classified) Locations*.

Nonincendive Field Wiring. Wiring that enters or leaves an equipment enclosure and, under normal operating conditions of the equipment, is not capable, due to arcing or thermal effects, of igniting the flammable gas-air, vapor-air, or dust-air mixture. Normal operation includes opening, shorting, or grounding the field wiring.

Nonincendive Field Wiring Apparatus. Apparatus intended to be connected to nonincendive field wiring.

Informational Note: For further information see ANSI/ISA-12.12.01-2012, *Nonincendive Electrical Equipment for Use in Class I and II, Division 2, and Class III, Divisions 1 and 2 Hazardous (Classified) Locations*.

Oil Immersion. Electrical equipment immersed in a protective liquid in such a way that an explosive atmosphere that may be above the liquid or outside the enclosure cannot be ignited.

Purged and Pressurized. The process of (1) purging, supplying an enclosure with a protective gas at a sufficient flow and positive pressure to reduce the concentration of any flammable gas or vapor initially present to an acceptable level; and (2) pressurization, supplying an

enclosure with a protective gas with or without continuous flow at sufficient pressure to prevent the entrance of a flammable gas or vapor, a combustible dust, or an ignitable fiber.

Informational Note: For further information, see ANSI/ NFPA 496-2013, *Purged and Pressurized Enclosures for Electrical Equipment*.

Unclassified Locations. Locations determined to be neither Class I, Division 1; Class I, Division 2; Class I, Zone 0; Class I, Zone 1; Class I, Zone 2; Class II, Division 1; Class II, Division 2; Class III, Division 1; Class III, Division 2; Zone 20; Zone 21; Zone 22; or any combination thereof.

A commonly used term in industrial is to also refer to “unclassified locations” as “ordinary locations”. These terms have the same meaning.

500.3 Other Articles. Except as modified in Articles 500 through 504, all other applicable rules contained in this *Code* shall apply to electrical equipment and wiring installed in hazardous (classified) locations.

500.4 - General.

(A) Documentation. All areas designated as hazardous (classified) locations shall be properly documented. This documentation shall be available to those authorized to design, install, inspect, maintain, or operate electrical equipment at the location.

(B) Reference Standards. Important information relating to topics covered in Chapter 5 may be found in other publications.

Informational Note No. 1: It is important that the authority having jurisdiction be familiar with recorded industrial experience as well as with the standards of the National Fire Protection Association (NFPA), the American Petroleum Institute (API), and the International Society of Automation (ISA) that may be of use in the classification of various locations, the determination of adequate ventilation, and the protection against static electricity and lightning hazards.

Informational Note No. 2: For further information on the classification of locations, see NFPA 30-2012, *Flammable and Combustible Liquids Code*; NFPA 32-2011, *Standard for Drycleaning Plants*; NFPA 33-2007, *Standard for Spray Application Using Flammable or Combustible Materials*; NFPA 34-2007, *Standard for Dipping and Coating Processes Using Flammable or Combustible Liquids*; NFPA 35-2011, *Standard for the Manufacture of Organic Coatings*; NFPA 36-2013, *Standard for Solvent Extraction Plants*; NFPA 45-2004, *Standard on Fire Protection for Laboratories Using Chemicals*; NFPA 55-2013, *Standard for the Storage, Use, and Handling of Compressed Gases and Cryogenic Fluids in Portable and Stationary Containers, Cylinders, and Tanks*; NFPA 58-2014, *Liquefied Petroleum Gas Code*; NFPA 59-2012, *Utility LP-Gas Plant Code*; NFPA 497-2012, *Recommended Practice for the Classification of Flammable Liquids, Gases, or Vapors and of Hazardous (Classified) Locations for Electrical Installations in Chemical Process Areas*; NFPA 499-2013, *Recommended Practice for the Classification of Combustible Dusts and of Hazardous (Classified) Locations for Electrical Installations in Chemical Process Areas*; NFPA 820-2012, *Standard for Fire Protection in Wastewater Treatment and Collection Facilities*; ANSI/API RP500-2012, *Recommended Practice for Classification of Locations of Electrical Installations at Petroleum Facilities Classified as Class I, Division 1 and Division 2*; ISA-12.10-1988, *Area Classification in Hazardous (Classified) Dust Locations*.

Informational Note No. 3: For further information on protection against static electricity and lightning hazards in hazardous (classified) locations, see NFPA 77-2014, *Recommended Practice on Static Electricity*; NFPA 780-2014, *Standard for the Installation of Lightning Protection Systems*; and API RP 2003-1998, *Protection Against Ignitions Arising Out of Static Lightning and Stray Currents*.

Informational Note No. 4: For further information on ventilation, see NFPA 30-2012, *Flammable and Combustible Liquids Code*; and ANSI/API RP 500-2012, *Recommended Practice for Classification of Locations for Electrical Installations at Petroleum Facilities Classified as Class I, Division 1 and Division 2*.

INTERPRETATION OF ARTICLE 500: HAZARDOUS (CLASSIFIED) LOCATIONS, CLASSES I, II, AND III, DIVISIONS 1 AND 2

Informational Note No. 5: For further information on electrical systems for hazardous (classified) locations on offshore oil- and gas-producing platforms, see ANSI/API RP 14F-1999, *Recommended Practice for Design and Installation of Electrical Systems for Fixed and Floating Offshore Petroleum Facilities for Unclassified and Class I, Division 1 and Division 2 Locations*.

500.5 - Classification of Locations.

(A) Classifications of Locations. Locations shall be classified depending on the properties of the flammable gas, flammable liquid-produced vapor, combustible liquid-produced vapors, combustible dusts, or fibers/flyings that may be present, and the likelihood that a flammable or combustible concentration or quantity is present. Each room, section, or area shall be considered individually in determining its classification. Where pyrophoric materials are the only materials used or handled, these locations are outside the scope of this article.

Revised to more clearly indicate that pyrophoric materials are outside of the scope of Article 500.

Informational Note: Through the exercise of ingenuity in the layout of electrical installations for hazardous (classified) locations, it is frequently possible to locate much of the equipment in a reduced level of classification or in an unclassified location and, thus, to reduce the amount of special equipment required.

Rooms and areas containing ammonia refrigeration systems that are equipped with adequate mechanical ventilation may be classified as “unclassified” locations.

Informational Note: For further information regarding classification and ventilation of areas involving ammonia, see ANSI/ASHRAE 15-1994, *Safety Code for Mechanical Refrigeration*, and ANSI/CGA G2.1-1989, *Safety Requirements for the Storage and Handling of Anhydrous Ammonia*.

Hazardous locations are classified by the type of the hazard present, represented by the Class, and by the degree to which the hazard is present, represented by the Division. The *NEC*[®] only addresses classification of locations that are hazardous due to the presence of flammable gases, flammable liquid-produced vapors, combustible liquid-produced vapors or combustible dusts or ignitable flyings/fibers. Pyrophoric materials are not covered. A Pyrophoric material is any material that ignites spontaneously or emits sparks when rubbed, scratched, or struck.

Flammable liquid-produced and combustible liquid-produced vapors are also required to be a consideration when classifying locations. Although these types of areas traditionally have been addressed during the classification determination process they now are specifically noted as a rule to be considered as classification as a Class I, Division 1 and Class I, Division 2 classified area.

(B) Class I Locations. Class I locations are those in which flammable gases, flammable liquid-produced vapors, or combustible liquid-produced vapors are or may be present in the air in quantities sufficient to produce explosive or ignitable mixtures. Class I locations shall include those specified in 500.5(B)(1) and (B)(2).

(1) Class I, Division 1. A Class I, Division 1 location is a location

(1) In which ignitable concentrations of flammable gases, flammable liquid-produced vapors, or combustible liquid-produced vapors can exist under normal operating conditions, or

(2) In which ignitable concentrations of such flammable gases, flammable liquid-produced vapors, or combustible liquids above their flash points may exist frequently because of repair or maintenance operations or because of leakage, or

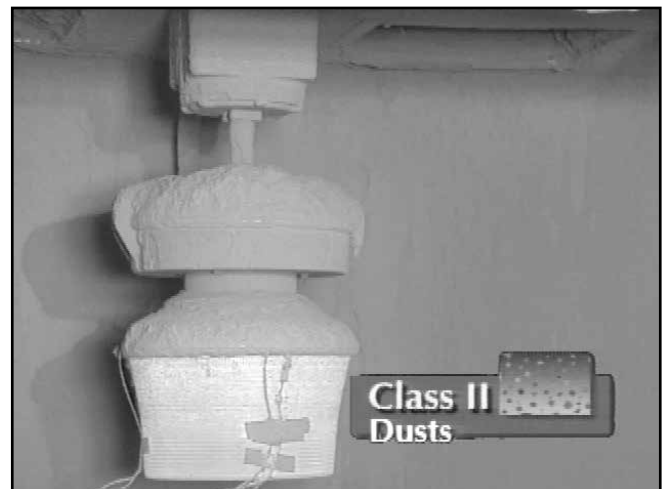

INTERPRETATION OF ARTICLE 500: HAZARDOUS (CLASSIFIED) LOCATIONS, CLASSES I, II, AND III, DIVISIONS 1 AND 2

(3) In which breakdown or faulty operation of equipment or processes might release ignitable concentrations of flammable gases, flammable liquid–produced vapors, or combustible liquid–produced vapors and might also cause simultaneous failure of electrical equipment in such a way as to directly cause the electrical equipment to become a source of ignition.

Informational Note No. 1: This classification usually includes the following locations:

- (1) Where volatile flammable liquids or liquefied flammable gases are transferred from one container to another
- (2) Interiors of spray booths and areas in the vicinity of spraying and painting operations where volatile flammable solvents are used
- (3) Locations containing open tanks or vats of volatile flammable liquids
- (4) Drying rooms or compartments for the evaporation of flammable solvents
- (5) Locations containing fat- and oil-extraction equipment using volatile flammable solvents
- (6) Portions of cleaning and dyeing plants where flammable liquids are used
- (7) Gas generator rooms and other portions of gas manufacturing plants where flammable gas may escape
- (8) Inadequately ventilated pump rooms for flammable gas or for volatile flammable liquids
- (9) The interiors of refrigerators and freezers in which volatile flammable materials are stored in open, lightly stoppered, or easily ruptured containers
- (10) All other locations where ignitable concentrations of flammable vapors or gases are likely to occur in the course of normal operations

Informational Note No. 2: In some Division 1 locations, ignitable concentrations of flammable gases or vapors may be present continuously or for long periods of time. Examples include the following:

- (1) The inside of inadequately vented enclosures containing instruments normally venting flammable gases or vapors to the interior of the enclosure
- (2) The inside of vented tanks containing volatile flammable liquids
- (3) The area between the inner and outer roof sections of a floating roof tank containing volatile flammable fluids
- (4) Inadequately ventilated areas within spraying or coating operations using volatile flammable fluids
- (5) The interior of an exhaust duct that is used to vent ignitable concentrations of gases or vapors

Experience has demonstrated the prudence of avoiding the installation of instrumentation or other electrical equipment in these particular areas altogether or where it cannot be avoided because it is essential to the process and other locations are not feasible [see 500.5(A), Informational Note] using electrical equipment or instrumentation approved for the specific application or consisting of intrinsically safe systems as described in Article 504.

In summary, a Class I, Division 1 location is one where there is or may be an explosive atmosphere of gases or vapors mixed with air present during normal operation, for any reason.

(2) **Class I, Division 2.** A Class I, Division 2 location is a location

(1) In which volatile flammable gases, flammable liquid–produced vapors, or combustible liquid–produced vapors are handled, processed, or used, but in which the liquids, vapors, or gases will normally be confined within closed containers or closed systems from which they can escape only in case of accidental rupture or breakdown of such containers or systems or in case of abnormal operation of equipment, or

(2) In which ignitable concentrations of flammable gases, flammable liquid–produced vapors, or combustible liquid–produced vapors are normally prevented by positive mechanical ventilation and which might become hazardous through failure or abnormal operation of the ventilating equipment, or

(3) That is adjacent to a Class I, Division 1 location, and to which ignitable concentrations of flammable gases, flammable liquid–produced vapors, or combustible liquid–produced vapors above their flash points might occasionally be communicated unless such communication is prevented by adequate positive-pressure ventilation from a source of clean air and effective safeguards against ventilation failure are provided.

Informational Note No. 1: This classification usually includes locations where volatile flammable liquids or flammable gases or vapors are used but that, in the judgment of the authority having jurisdiction, would become hazardous only in case of an accident or of some unusual operating condition. The quantity of flammable material that might escape in case of accident, the adequacy of ventilating equipment, the total area involved, and the record of the industry or business with respect to explosions or fires are all factors that merit consideration in determining the classification and extent of each location.

Informational Note No. 2: Piping without valves, checks, meters, and similar devices would not ordinarily introduce a hazardous condition even though used for flammable liquids or gases. Depending on factors such as the quantity and size of the containers and ventilation, locations used for the storage of flammable liquids or liquefied or compressed gases in sealed containers may be considered either hazardous (classified) or unclassified locations. See NFPA 30-2012, *Flammable and Combustible Liquids Code*, and NFPA 58-2014, *Liquefied Petroleum Gas Code*.

In summary, a Class I, Division 2 location is one where there is an explosive atmosphere of gases or vapors mixed with air when an abnormal condition exists, such as failure of a containment wall or ventilation system.

(C) **Class II Locations.** Class II locations are those that are hazardous because of the presence of combustible dust. Class II locations shall include those specified in 500.5(C)(1) and (C)(2).

(1) **Class II, Division 1.** A Class II, Division 1 location is a location

(1) In which combustible dust is in the air under normal operating conditions in quantities sufficient to produce explosive or ignitable mixtures, or

(2) Where mechanical failure or abnormal operation of machinery or equipment might cause such explosive or ignitable mixtures to be produced, and might also provide a source of ignition through simultaneous failure of electrical equipment, through operation of protection devices, or from other causes, or

(3) In which Group E combustible dusts may be present in quantities sufficient to be hazardous.

Informational Note: Dusts containing magnesium or aluminum are particularly hazardous, and the use of extreme precaution is necessary to avoid ignition and explosion.

INTERPRETATION OF ARTICLE 500: HAZARDOUS (CLASSIFIED) LOCATIONS, CLASSES I, II, AND III, DIVISIONS 1 AND 2

This section specifically references Group E metal dust. This is a more appropriate reference than “dusts of an electrically conductive nature”, which is vague, since just about any dust can become electrically conductive when it has a high enough moisture content.

(2) Class II, Division 2. A Class II, Division 2 location is a location

(1) In which combustible dust due to abnormal operations may be present in the air in quantities sufficient to produce explosive or ignitable mixtures; or

(2) Where combustible dust accumulations are present but are normally insufficient to interfere with the normal operation of electrical equipment or other apparatus, but could as a result of infrequent malfunctioning of handling or processing equipment become suspended in the air; or

(3) In which combustible dust accumulations on, in, or in the vicinity of the electrical equipment could be sufficient to interfere with the safe dissipation of heat from electrical equipment, or could be ignitable by abnormal operation or failure of electrical equipment.

Informational Note No. 1: The quantity of combustible dust that may be present and the adequacy of dust removal systems are factors that merit consideration in determining the classification and may result in an unclassified area.

Informational Note No. 2: Where products such as seed are handled in a manner that produces low quantities of dust, the amount of dust deposited may not warrant classification.

The definition separates the dust accumulation issue from the dust suspension probability issue.

(D) Class III Locations. Class III locations are those that are hazardous because of the presence of easily ignitable fibers or where materials producing combustible flyings are handled, manufactured, or used, but in which such fibers/flyings are not likely to be in suspension in the air in quantities sufficient to produce ignitable mixtures. Class III locations shall include those specified in 500.5(D)(1) and (D)(2).

(1) Class III, Division 1. A Class III, Division 1 location is a location in which easily ignitable fibers/flyings are handled, manufactured, or used.

Informational Note No. 1: Such locations usually include some parts of rayon, cotton, and other textile mills; combustible fibers/flyings manufacturing and processing plants; cotton gins and cotton-seed mills; flax-processing plants; clothing manufacturing plants; woodworking plants; and establishments and industries involving similar hazardous processes or conditions.

Informational Note No. 2: Easily ignitable fibers/flyings include rayon, cotton (including cotton linters and cotton waste), sisal or henequen, istle, jute, hemp, tow, cocoa fiber, oakum, baled waste kapok, Spanish moss, excelsior, and other materials of similar nature.

(2) Class III, Division 2. A Class III, Division 2 location is a location in which easily ignitable fibers/flyings are stored or handled other than in the process of manufacture.

500.6 Material Groups. For purposes of testing, approval, and area classification, various air mixtures (not oxygen-enriched) shall be grouped in accordance with 500.6(A) and (B).

Exception: Equipment identified for a specific gas, vapor, or dust.

Informational Note: This grouping is based on the characteristics of the materials. Facilities

are available for testing and identifying equipment for use in the various atmospheric groups.

(A) Class I Group Classifications. Class I groups shall be according to 500.6(A)(1) through (A)(4).

Informational Note No. 1: Informational Note Nos. 2 and 3 apply to 500.6(A).

Informational Note No. 2: The explosion characteristics of air mixtures of gases or vapors vary with the specific material involved. For Class I locations, Groups A, B, C, and D, the classification involves determinations of maximum explosion pressure and maximum safe clearance between parts of a clamped joint in an enclosure. It is necessary, therefore, that equipment be identified not only for class but also for the specific group of the gas or vapor that will be present.

Informational Note No. 3: Certain chemical atmospheres may have characteristics that require safeguards beyond those required for any of the Class I groups. Carbon disulfide is one of these chemicals because of its low autoignition temperature (90°C) and the small joint clearance permitted to arrest its flame.

GROUPS A, B, C AND D (CLASS I)

Potentially explosive gases and vapors are divided into four groups, A, B, C, and D. NFPA 497, “*Classification of Flammable Liquids, Gases, or Vapors and of Hazardous (Classified) Locations for Electrical Installations in Chemical Process Areas*”, contains information on which gases and vapors go into each of these groups, and also provides information on how to classify hazardous areas due to the presence of flammable gases and vapors.

The four gas groups were created so that electrical equipment intended to be used in hazardous (classified) locations could be rated for families of gases and vapors, and tested with a designated worst-case gas/air mixture to cover the entire group. If electrical equipment will be used only in the presence of one flammable gas, the testing can be done with that gas instead of the designated test gas.

There are four characteristics of flammable gases that are critical to the design of electrical equipment to be used in hazardous (classified) locations. These characteristics are: maximum experimental safe gap (MESG), minimum igniting current ratio (MIC ratio), maximum explosion pressure, and autoignition temperature.

The gases fall into Gas Groups A, B, C or D based on two of these characteristics: MESG and MIC ratio.

The MESG is determined by using a device called the Westerberg apparatus. This device has two chambers that are separated by two parallel metal plates. The plates can be adjusted to different gaps between them. A flammable gas/air mixture is introduced into both sides of the apparatus, and is then ignited on one side. The MESG is the maximum gap between the two plates that will not cause ignition of the gas in the volume without the ignition source.

MESG is important in the design of explosionproof enclosures, which rely on the enclosure to keep an ignition inside the enclosure from propagating to the outside atmosphere. Enclosures for gases with a small MESG number will require smaller gaps in their joints and tighter tolerances than those designed for gases with higher MESG numbers.

The MIC ratio is the minimum current required in a specified inductive ignition device that will ignite a gas/air mixture; divided by the minimum current required to ignite a methane/air mixture, using

INTERPRETATION OF ARTICLE 500: HAZARDOUS (CLASSIFIED) LOCATIONS, CLASSES I, II, AND III, DIVISIONS 1 AND 2

the same inductive ignition device. The resulting MIC ratio compares the minimum ignition energy of the gas/air mixture being tested, to the minimum ignition energy of methane. The most likely reason that methane is used as the reference is because the early work in hazardous location safety was done in coal mines where methane is the gas most often encountered.

The minimum ignition energy is important in the design of an intrinsically safe apparatus, which limits the energy that can be stored and released by any part of a circuit to less than the minimum ignition energy of the gas or vapor that will be present in use.

The maximum explosion pressure is the peak pressure produced inside an enclosure when the designated test gas/air mixture is ignited inside of it. This parameter is important in the design of explosionproof enclosures, since the housing has to survive a hydrostatic pressure test, without permanent deformation, to a pressure based on a multiple of the maximum explosion pressure.

The substance's autoignition temperature is the lowest temperature at which it will burst into flame in air, even without an external spark or other source. This parameter is important for all methods of protection. The autoignition temperature, however, has no correlation to MESG or the MIC ratio. For example, hydrogen has both a very low MESG and MIC ratio, but has a very high autoignition temperature over 500°C.

The gas groups, from A to D, contain gases with MESG values and MIC ratios that go from smallest to largest.

More information on the properties of flammable gases and vapors can be found in Appendix A.

(1) Group A. Acetylene. [497:3.3.5.1.1]

Gas Group A contains only acetylene. Acetylene has similar MESG and MIC ration numbers to hydrogen, but is separated into its own group because of two other reasons. Acetylene will form hot particles when combusted in concentrations with air over about 30%, and design considerations for Group A enclosures need to consider the ejection of these hot particles. Acetylene can also react with some metals and form unstable compounds. Acetylene is the designated test gas for Group A.

(2) **Group B.** Flammable gas, flammable liquid–produced vapor, or combustible liquid–produced vapor mixed with air that may burn or explode, having either a maximum experimental safe gap (MESG) value less than or equal to 0.45 mm or a minimum igniting current ratio (MIC ratio) less than or equal to 0.40. [497:3.3.5.1.2]

Informational Note: A typical Class I, Group B material is hydrogen.

Exception No. 1: Group D equipment shall be permitted to be used for atmospheres containing butadiene, provided all conduit runs into explosionproof equipment are provided with explosionproof seals installed within 450 mm (18 in.) of the enclosure.

Exception No. 2: Group C equipment shall be permitted to be used for atmospheres containing allyl glycidyl ether, n-butyl glycidyl ether, ethylene oxide, propylene oxide, and acrolein, provided all conduit runs into explosionproof equipment are provided with explosionproof seals installed within 450 mm (18 in.) of the enclosure.

There are two exceptions allowed by this section. These exceptions are allowed for explosionproof equipment, because the gases specified in both

exceptions have minimum ignition energies that put them into the Group B range, but have MESG values that are in the range of Group D for butadiene, and in Group C for the gases in Exception No. 2. Minimum ignition energy is not a critical factor in the performance of explosionproof enclosures, but it is for other methods of protection, such as intrinsic safety. Therefore, these exceptions are only valid for explosionproof applications. The explosionproof conduit seals are required to minimize the passage of gases and vapors and prevent the passage of flames.

(3) **Group C.** Flammable gas, flammable liquid–produced vapor, or combustible liquid–produced vapor mixed with air that may burn or explode, having either a maximum experimental safe gap (MESG) value greater than 0.45 mm and less than or equal to 0.75 mm, or a minimum igniting current ratio (MIC ratio) greater than 0.40 and less than or equal to 0.80. [497:3.3.5.1.3]

Informational Note: A typical Class I, Group C material is ethylene.

Gas Group C contains flammable gas having either an MESG value greater than 0.45 mm and less than or equal to 0.75 mm, or an MIC ratio greater than 0.40 and less than or equal to 0.80. Ethylene is the designated test gas for Group C.

(4) **Group D.** Flammable gas, flammable liquid–produced vapor, or combustible liquid–produced vapor mixed with air that may burn or explode, having either a maximum experimental safe gap (MESG) value greater than 0.75 mm or a minimum igniting current ratio (MIC ratio) greater than 0.80. [497:3.3.5.1.4]

Informational Note No. 1: A typical Class I, Group D material is propane.

Informational Note No. 2: For classification of areas involving ammonia atmospheres, see ANSI/ASHRAE 15-1994, *Safety Code for Mechanical Refrigeration*, and ANSI/CGA G2.1-1989, *Safety Requirements for the Storage and Handling of Anhydrous Ammonia*.

Ammonia is a Group D gas that is often encountered and widely used as a component in refrigerants and fertilizers. For classification of areas involving ammonia, see ANSI/ASHRAE 15-1994, *Safety Code for Mechanical Refrigeration*, and ANSI/CGA G2.1 1989, *Safety Requirements for the Storage and Handling of Anhydrous Ammonia*.

(B) **Class II Group Classifications.** Class II groups shall be in accordance with 500.6(B)(1) through (B)(3).

GROUPS E, F AND G (CLASS II)

Combustible dusts are defined as any finely divided solid material 420 microns or less in diameter (U.S. No. 40 Standard Sieve or smaller), and are divided into three Groups, E, F, and G. NFPA 499, *Classification of Combustible Dusts and of Hazardous (Classified) Locations for Electrical Installations in Chemical Process Areas*, contains information on which dusts go into each of these groups, and also provides information on how to classify hazardous areas due to the presence of combustible dusts.

More information on the properties of combustible dusts can be found in Appendix A-5 and A-6.

(1) **Group E.** Atmospheres containing combustible metal dusts, including aluminum, magnesium, and their commercial alloys, or other combustible dusts whose particle size, abrasiveness, and conductivity present similar hazards in the use of electrical equipment. [499:3.3.4.1]

Informational Note: Certain metal dusts may have characteristics that require safeguards

INTERPRETATION OF ARTICLE 500: HAZARDOUS (CLASSIFIED) LOCATIONS, CLASSES I, II, AND III, DIVISIONS 1 AND 2

beyond those required for atmospheres containing the dusts of aluminum, magnesium, and their commercial alloys. For example, zirconium, thorium, and uranium dusts have extremely low ignition temperatures [as low as 20°C (68°F)] and minimum ignition energies lower than any material classified in any of the Class I or Class II groups.

Section 500.6(B)(1) states that “Group E dusts are considered to be electrically conductive.” These dusts are metal dusts, such as aluminum, magnesium, and their commercial alloys or other dusts of small particle size, abrasiveness and/or electrical conductivity as to present a similar hazard. Although electrical conductivity is not a major criteria for classifying dusts into Groups, it is a characteristic nature of Group E dusts. If the dust is electrically conductive, caution is advised, as these dusts may ignite from bridging the gap between energized terminals, from arcs or from failure of equipment. Where Group E dusts are present in hazardous quantities, only Class II, Division 1 electrical equipment can be used. There is no such classification as Class II, Division 2, Group E. There is no middle ground. Either the location contains enough electrically conductive dusts to make it a Division 1 location, or there is not enough dust present to make it a hazardous location. However, great care must be taken, as only a small amount of electrically conductive combustible dust can make a location Class II, Division 1, Group E. Unless thorough tests are made, it is safer to use Division 1 equipment.

Group E contains combustible metal dusts. Any area that has a sufficient quantity of Group E dusts present to cause a hazard must be classified as Class II, Division 1. Classification as a Division 2 area is not allowed. Metal dusts can be extremely hazardous. Some metals, like magnesium, can burn even when under water.

(2) Group F. Atmospheres containing combustible carbonaceous dusts that have more than 8 percent total entrapped volatiles (see ASTM D 3175-02, *Standard Test Method for Volatile Matter in the Analysis Sample for Coal and Coke*, for coal and coke dusts) or that have been sensitized by other materials so that they present an explosion hazard. Coal, carbon black, charcoal, and coke dusts are examples of carbonaceous dusts. [\[499:3.3.4.2\]](#)

Informational Note: Testing of specific dust samples, following established ASTM testing procedures, is a method used to identify the combustibility of a specific dust and the need to classify those locations containing that material as Group F.

(3) Group G. Atmospheres containing combustible dusts not included in Group E or F, including flour, grain, wood, plastic, and chemicals. [\[499:3.3.4.3\]](#)

Informational Note No. 1: For additional information on group classification of Class II materials, see NFPA 499-2013, *Recommended Practice for the Classification of Combustible Dusts and of Hazardous (Classified) Locations for Electrical Installations in Chemical Process Areas*.

Informational Note No. 2: The explosion characteristics of air mixtures of dust vary with the materials involved. For Class II locations, Groups E, F, and G, the classification involves the tightness of the joints of assembly and shaft openings to prevent the entrance of dust in the dust-ignitionproof enclosure, the blanketing effect of layers of dust on the equipment that may cause overheating, and the ignition temperature of the dust. It is necessary, therefore, that equipment be identified not only for the class but also for the specific group of dust that will be present.

Informational Note No. 3: Certain dusts may require additional precautions due to chemical phenomena that can result in the generation of ignitable gases. See ANSI/IEEE C2-2012, *National Electrical Safety Code*, Section 127A, Coal Handling Areas.

500.7 Protection Techniques. Section 500.7(A) through (L) shall be acceptable protection techniques for electrical and electronic equipment in hazardous (classified) locations.

(A) Explosionproof Equipment. This protection technique shall be permitted for equipment in Class I, Division 1 or 2 locations.

Explosionproof enclosures are very widely used to protect electrical equipment in hazardous (classified) locations. The protection concept works by enclosing the electrical apparatus inside a robust housing, where every path from the inside of the enclosure to the outside, called a flame path, is controlled. If a flammable atmosphere gets inside the enclosure and is ignited by the electrical apparatus, the flame paths will prevent that ignition from being transmitted to the flammable atmosphere outside the enclosure. The outside surface temperature of the explosionproof enclosure also must be controlled so it does not become an ignition source for the outside atmosphere. More information on explosionproof enclosures and flame path construction can be found on pages 6 and 7.

(B) Dust Ignitionproof. This protection technique shall be permitted for equipment in Class II, Division 1 or 2 locations.

(C) Dusttight. This protection technique shall be permitted for equipment in Class II, Division 2 or Class III, Division 1 or 2 locations.

Dust protection concepts work by ensuring enclosures that are used in Class II environments keep dust from entering enclosures in quantities large enough to cause a problem with the electrical equipment inside. For dust-ignitionproof enclosures the outside surface temperature of the enclosure also must be controlled to avoid thermal ignition of a dust cloud, or burning of a dust layer on the enclosure.

(D) Purged and Pressurized. This protection technique shall be permitted for equipment in any hazardous (classified) location for which it is identified.

Purging can be used to keep a hazardous atmosphere from reaching its lower flammable limit (LFL) or pressurizing with clean air or inert gas can be used to keep flammable gas or dust out of an enclosure, or even entire rooms or buildings. If inert gas is used in areas where personnel will be present, care must be taken to avoid any asphyxiation hazards.

(E) Intrinsic Safety. This protection technique shall be permitted for equipment in Class I, Division 1 or 2; or Class II, Division 1 or 2; or Class III, Division 1 or 2 locations. The provisions of Articles 501 through 503 and Articles 510 through 516 shall not be considered applicable to such installations, except as required by Article 504, and installation of intrinsically safe apparatus and wiring shall be in accordance with the requirements of Article 504.

Intrinsic safety does not depend on an enclosure to protect electrical apparatus. Intrinsic safety is a system consisting of a special power limiter (associated apparatus) located in the unclassified area, the wiring to the unit in the hazardous area, and the hazardous area apparatus. This system is designed so that it is not capable of storing and releasing enough energy in the hazardous location to ignite a flammable atmosphere. The system must be safe even with up to two faults applied to the circuit. Intrinsic safety, because of the limited amount of power that can be transmitted to the hazardous location, is limited to instrumentation and other applications that do not use much power. This is especially true for Gas Groups A and B, where the gases have very low ignition energies. In addition to Division 1 wiring methods, any ordinary location wiring method can be used for the wiring between the associated apparatus in the safe area and the hazardous location apparatus, provided the wiring is separated adequately from other circuits. This is possible because there is not enough energy in each intrinsically safe circuit to cause an ignition capable spark, even if the wires are shorted to each other or to ground.

INTERPRETATION OF ARTICLE 500: HAZARDOUS (CLASSIFIED) LOCATIONS, CLASSES I, II, AND III, DIVISIONS 1 AND 2

(F) Nonincendive Circuit. This protection technique shall be permitted for equipment in Class I, Division 2; Class II, Division 2; or Class III, Division 1 or 2 locations.

Nonincendive circuits are energy limited, like intrinsically safe circuits for Division 1; they cannot release enough energy to cause a flammable atmosphere to ignite. Unlike intrinsically safe circuits, they are evaluated with no faults applied, since the risk in Division 2 of having a flammable atmosphere present is lower. These circuits can also be installed using ordinary location wiring methods, provided adequate separation from other circuits is maintained.

(G) Nonincendive Equipment. This protection technique shall be permitted for equipment in Class I, Division 2; Class II, Division 2; or Class III, Division 1 or 2 locations.

Nonincendive equipment does not depend on an enclosure as protection against causing ignition of a flammable atmosphere. It has no normally arcing or sparking components that are not protected by other methods, and has no hot surface capable of causing thermal ignition of a flammable atmosphere. Nonincendive equipment may have both incendive and nonincendive circuit connections, for instance, a 120 V connection for power, which is incendive; and a signal or sensor circuit that is nonincendive. Appropriate Division 2 wiring methods must always be used to wire incendive circuits.

(H) Nonincendive Component. This protection technique shall be permitted for equipment in Class I, Division 2; Class II, Division 2; or Class III, Division 1 or 2 locations.

A nonincendive component is treated the same as nonincendive equipment. The wiring connections to a nonincendive component may be either incendive or nonincendive, and must be installed appropriately.

(I) Oil Immersion. This protection technique shall be permitted for current-interrupting contacts in Class I, Division 2 locations as described in 501.115(B)(1)(2).

Oil immersion works by submerging arcing or sparking contacts in a noncombustible mineral oil, isolating the flammable atmosphere from the ignition source. This method of protection is not very widely used anymore, since it requires frequent maintenance.

(J) Hermetically Sealed. This protection technique shall be permitted for equipment in Class I, Division 2; Class II, Division 2; or Class III, Division 1 or 2 locations.

Hermetic sealing isolates ignition capable arcing or sparking contacts from flammable atmospheres by placing them in an enclosure that is sealed gastight, by using fusion joints of metal, glass, or ceramic materials.

(K) Combustible Gas Detection System. A combustible gas detection system shall be permitted as a means of protection in industrial establishments with restricted public access and where the conditions of maintenance and supervision ensure that only qualified persons service the installation. Where such a system is installed, equipment specified in 500.7(K)(1), (K)(2), or (K)(3) shall be permitted.

The type of detection equipment, its listing, installation location(s), alarm and shutdown criteria, and calibration frequency shall be documented when combustible gas detectors are used as a protection technique.

Informational Note No. 1: For further information, see ANSI/ISA-60079-29-1, *Explosive Atmospheres – Part 29-1: Gas Detectors – Performance Requirements of detectors for flammable gases*, and ANSI/UL 2075, *Gas and Vapor Detectors and Sensors*.

Informational Note No. 2: For further information, see ANSI/API RP 500–Revised 2002, *Recommended Practice for Classification of Locations for Electrical Installations at Petroleum Facilities Classified as Class I, Division 1 or Division 2*.

Informational Note No. 3: For further information, see ANSI/ISA-60079-29-2, *Explosive Atmospheres – Part 29-2: Gas detectors – Selection, installation, use and maintenance of detectors for flammable gases and oxygen*.

Informational Note No. 4: For further information, see ISA-TR 12.13.03-2009 *Guide for Combustible Gas Detection as a Method of Protection*.

(1) Inadequate Ventilation. In a Class I, Division 1 location that is so classified due to inadequate ventilation, electrical equipment suitable for Class I, Division 2 locations shall be permitted. Combustible gas detection equipment shall be listed for Class I, Division 1, for the appropriate material group, and for the detection of the specific gas or vapor to be encountered.

(2) Interior of a Building. In a building located in, or with an opening into, a Class I, Division 2 location where the interior does not contain a source of flammable gas or vapor, electrical equipment for unclassified locations shall be permitted. Combustible gas detection equipment shall be listed for Class I, Division 1 or Class I, Division 2, for the appropriate material group, and for the detection of the specific gas or vapor to be encountered.

(3) Interior of a Control Panel. In the interior of a control panel containing instrumentation utilizing or measuring flammable liquids, gases, or vapors, electrical equipment suitable for Class I, Division 2 locations shall be permitted. Combustible gas detection equipment shall be listed for Class I, Division 1, for the appropriate material group, and for the detection of the specific gas or vapor to be encountered.

Protection of electrical apparatus using combustible gas detection works by using these detectors, rated for use in the hazardous area, to shut down equipment when the flammable gas level gets to a predetermined point, usually 25% of the LFL. This protection method was introduced to allow the use of Division 2 rated equipment in Division 1 under certain conditions, or to allow the use of ordinary location equipment in Division 2. There are some circumstances where specialized equipment that is not hazardous area rated has to be used in a hazardous area to maintain the overall safety of the process. Use of this protection scheme should be very rare. There is a great deal of engineering and technical expertise necessary to successfully implement protection of this type, and that is why it is limited to industrial establishments with limited public access.

Documentation for the application of the combustible gas detection protection method is required.

Sections 500.7(K)(1); 500.7(K)(2); and 500.7(K)(3) now require that combustible gas detection equipment be listed for the appropriate gas group and for the detection of the specific gas or vapor to be encountered.

(L) Other Protection Techniques. Other protection techniques used in equipment identified for use in hazardous (classified) locations.

500.8 Equipment. Articles 500 through 504 require equipment construction and installation that ensure safe performance under conditions of proper use and maintenance.

INTERPRETATION OF ARTICLE 500: HAZARDOUS (CLASSIFIED) LOCATIONS, CLASSES I, II, AND III, DIVISIONS 1 AND 2

Informational Note No. 1: It is important that inspection authorities and users exercise more than ordinary care with regard to installation and maintenance.

Informational Note No. 2: Since there is no consistent relationship between explosion properties and ignition temperature, the two are independent requirements.

Informational Note 2 reinforces the point that ignition temperature is unrelated to the other properties of gases that cause them to be classified into either Groups A, B, C, or D.

Informational Note No. 3: Low ambient conditions require special consideration. Explosionproof or dust-ignitionproof equipment may not be suitable for use at temperatures lower than -25°C (-13°F) unless they are identified for low-temperature service. However, at low ambient temperatures, flammable concentrations of vapors may not exist in a location classified as Class I, Division 1 at normal ambient temperature.

(A) Suitability. Suitability of identified equipment shall be determined by one of the following:

- (1) Equipment listing or labeling
- (2) Evidence of equipment evaluation from a qualified testing laboratory or inspection agency concerned with product evaluation
- (3) Evidence acceptable to the authority having jurisdiction such as a manufacturer's self-evaluation or an owner's engineering judgment.

Informational Note: Additional documentation for equipment may include certificates demonstrating compliance with applicable equipment standards, indicating special conditions of use, and other pertinent information. [Guidelines for certificates may be found in ANSI/ISA 12.00.02, Certificate Standard for AEx Equipment for Hazardous \(Classified\) Locations.](#)

Section 500.8 requires electrical equipment installed in a hazardous location has to meet the requirements to be used in that location, and gives three different ways that the information about the suitability of the equipment can be obtained. Equipment listing and labeling is the most common method of determining suitability however Appleton Grp LLC has the ability to provide evidence of suitability by the other permitted methods upon request.

(B) Approval for Class and Properties.

(1) Equipment shall be identified not only for the class of location but also for the explosive, combustible, or ignitable properties of the specific gas, vapor, dust, or fibers/flyings that will be present. In addition, Class I equipment shall not have any exposed surface that operates at a temperature in excess of the [autoignition](#) temperature of the specific gas or vapor. Class II equipment shall not have an external temperature higher than that specified in 500.8(D)(2). Class III equipment shall not exceed the maximum surface temperatures specified in 503.5.

Informational Note: Luminaires and other heat-producing apparatus, switches, circuit breakers, and plugs and receptacles are potential sources of ignition and are investigated for suitability in classified locations. Such types of equipment, as well as cable terminations for entry into explosionproof enclosures, are available as listed for Class I, Division 2 locations. Fixed wiring, however, may utilize wiring methods that are not evaluated with respect to classified locations. Wiring products such as cable, raceways, boxes, and fittings, therefore, are not marked as being suitable for Class I, Division 2 locations. Also see 500.8(C)(6)(a).

Some mechanical and electrical wiring products are necessary and acceptable to use in Class I, Division 2 hazardous locations in accordance with Chapter 5 of the *NEC*; however they generally will

not be marked as suitable for Class I, Division 2.

(2) Equipment that has been identified for a Division 1 location shall be permitted in a Division 2 location of the same class, group, and temperature class and shall comply with (a) or (b) as applicable.

(a) Intrinsically safe apparatus having a control drawing requiring the installation of associated apparatus for a Division 1 installation shall be permitted to be installed in a Division 2 location if the same associated apparatus is used for the Division 2 installation.

(b) Equipment that is required to be explosionproof shall incorporate seals in accordance with 501.15(A) or (D) when the wiring methods of 501.10(B) are employed.

Autoignition temperature is not related to other gas properties and has to be considered independently. Intrinsically safe installations are a system, and must be installed as a system in order to meet their design requirements, even when installed in Division 2. Explosionproof enclosures usually contain arcing and sparking devices, and the seals are necessary to maintain the integrity of the installation of the explosionproof enclosure in Division 2 as well as in Division 1.

(3) Where specifically permitted in Articles 501 through 503, general-purpose equipment or equipment in general-purpose enclosures shall be permitted to be installed in Division 2 locations if the equipment does not constitute a source of ignition under normal operating conditions.

Determining whether or not a particular piece of general-purpose equipment is suitable to use in a Division 2 location requires evidence of suitability from a qualified source.

(4) Equipment that depends on a single compression seal, diaphragm, or tube to prevent flammable or combustible fluids from entering the equipment shall be identified for a Class I, Division 2 location even if installed in an unclassified location. Equipment installed in a Class I, Division 1 location shall be identified for the Class I, Division 1 location.

Informational Note: Equipment used for flow measurement is an example of equipment having a single compression seal, diaphragm, or tube.

The above section recognizes that the inside of an electrical equipment enclosure that is connected to a flammable process through a single seal, is in fact a Division 2 area. Leakage or failure of the seal could produce a flammable atmosphere inside the equipment enclosure. Since the inside of the enclosure meets the definition of a Division 2 location, the electrical equipment must be identified as suitable for use in a Division 2 location, even if the location outside the enclosure is not classified. Measures that must be taken to ensure process gas or fluid does not enter the wiring raceway are addressed in Section 501.15(F)(3).

(5) Unless otherwise specified, normal operating conditions for motors shall be assumed to be rated full-load steady conditions.

(6) Where flammable gases, flammable liquid-produced vapors, combustible liquid-produced vapors, or combustible dusts are or may be present at the same time, the simultaneous presence of both shall be considered when determining the safe operating temperature of the electrical equipment.

Informational Note: The characteristics of various atmospheric mixtures of gases, vapors, and dusts depend on the specific material involved.

INTERPRETATION OF ARTICLE 500: HAZARDOUS (CLASSIFIED) LOCATIONS, CLASSES I, II, AND III, DIVISIONS 1 AND 2

Dust layers can cause an insulating effect that can raise the operating temperature of heat producing electrical equipment in normal operation. This might create a situation where an equipment surface temperature exposed to the flammable atmosphere would be cool enough for a particular flammable gas when dust is not present, but would be over the temperature rating of the same flammable gas when dust is present.

(C) Marking. Equipment shall be marked to show the environment for which it has been evaluated. Unless otherwise specified or allowed in (C)(6), the marking shall include the information specified in (C)(1) through (C)(5).

These marking requirements are required to be denoted on the equipment and not just on the carton labels or instructions.

(1) Class. The marking shall specify the class(es) for which the equipment is suitable.

(2) Division. The marking shall specify the division if the equipment is suitable for Division 2 only. Equipment suitable for Division 1 shall be permitted to omit the division marking.

Informational Note: Equipment not marked to indicate a division, or marked "Division 1" or "Div. 1," is suitable for both Division 1 and 2 locations; see 500.8(B)(2). Equipment marked "Division 2" or "Div. 2" is suitable for Division 2 locations only.

(3) Material Classification Group. The marking shall specify the applicable material classification group(s) in accordance with 500.6.

Exception: Fixed luminaires marked for use only in Class I, Division 2 or Class II, Division 2 locations shall not be required to indicate the group.

(4) Equipment Temperature. The marking shall specify the temperature class or operating temperature at a 40°C ambient temperature, or at the higher ambient temperature if the equipment is rated and marked for an ambient temperature of greater than 40°C. For equipment installed in a Class II, Division 1 location, the temperature class or operating temperature shall be based on operation of the equipment when blanketed with the maximum amount of dust that can accumulate on the equipment. The temperature class, if provided, shall be indicated using the temperature class (T codes) shown in Table 500.8(C). Equipment for Class I and Class II shall be marked with the maximum safe operating temperature, as determined by simultaneous exposure to the combinations of Class I and Class II conditions.

The product listing standards for Class II, Division 1 equipment requires that the temperature class and/or operating temperature be determined when the equipment is covered with the maximum amount of dust. Listed equipment for Class II, Division 1 has been evaluated in accordance with this requirement. This is not a new requirement in the product listing standards.

Exception: Equipment of the non-heat-producing type, such as junction boxes, conduit, and fittings, and equipment of the heat-producing type having a maximum temperature not more than 100°C shall not be required to have a marked operating temperature or temperature class.

Informational Note: More than one marked temperature class or operating temperature, for gases and vapors, dusts, and different ambient temperatures, may appear.

(5) Ambient Temperature Range. Electrical equipment designed for use in the ambient temperature range between -25°C to +40°C shall require no ambient temperature marking. For equipment rated for a temperature range other than -25°C to +40°C, the marking shall

specify the special range of ambient temperatures in degrees Celsius. The marking shall include either the symbol "Ta" or "Tamb."

Informational Note: As an example, such a marking might be "-30°C Ta +40°C."

Table 500.8(C) Classification of Maximum Surface Temperature

Maximum Temperature		Temperature Class
C°	F°	(T Code)
450	842	T1
300	572	T2
280	536	T2A
260	500	T2B
230	446	T2C
215	419	T2D
200	392	T3
180	356	T3A
165	329	T3B
160	320	T3C
135	275	T4
120	248	T4A
100	212	T5
85	185	T6

(6) Special Allowances.

(a) *General-Purpose Equipment.* Fixed general-purpose equipment in Class I locations, other than fixed luminaires, that is acceptable for use in Class I, Division 2 locations shall not be required to be marked with the class, division, group, temperature class, or ambient temperature range.

An example of this is fittings that are listed to the unclassified (ordinary) location standards. They are not specifically listed for Class I, Division 2 locations however the Code permits the installation of these fittings in a Class I, Division 2 location as they do not present an ignition source.

(b) *Dusttight Equipment.* Fixed dusttight equipment, other than fixed luminaires, that is acceptable for use in Class II, Division 2 and Class III locations shall not be required to be marked with the class, division, group, temperature class, or ambient temperature range.

(c) *Associated Apparatus.* Associated intrinsically safe apparatus and associated nonincendive field wiring apparatus that are not protected by an alternative type of protection shall not be marked with the class, division, group, or temperature class. Associated intrinsically safe apparatus and associated nonincendive field wiring apparatus shall be marked with the class, division, and group of the apparatus to which it is to be connected.

(d) *Simple Apparatus.* "Simple apparatus" as defined in Article 504, shall not be required to be marked with class, division, group, temperature class, or ambient temperature range.

(D) Temperature.

(1) Class I Temperature. The temperature marking specified in

INTERPRETATION OF ARTICLE 500: HAZARDOUS (CLASSIFIED) LOCATIONS, CLASSES I, II, AND III, DIVISIONS 1 AND 2

500.8(C) shall not exceed the autoignition temperature of the specific gas or vapor to be encountered.

Informational Note: For information regarding autoignition temperatures of gases and vapors, see NFPA 497-2013, *Recommended Practice for the Classification of Flammable Liquids, Gases, or Vapors, and of Hazardous (Classified) Locations for Electrical Installations in Chemical Process Areas*.

(2) Class II Temperature. The temperature marking specified in 500.8(C) shall be less than the ignition temperature of the specific dust to be encountered. For organic dusts that may dehydrate or carbonize, the temperature marking shall not exceed the lower of either the ignition temperature or 165°C (329°F).

Informational Note: See NFPA 499-2013, *Recommended Practice for the Classification of Combustible Dusts and of Hazardous (Classified) Locations for Electrical Installations in Chemical Process Areas*, for minimum ignition temperatures of specific dusts.

The ignition temperature for which equipment was approved prior to this requirement shall be assumed to be as shown in Table 500.8(D) (2).

Table 500.8(D)(2) Class II Temperatures

Class II Group	Equipment Not Subject to Overloading		Equipment (Such as Motors or Power Transformers) That May Be Overloaded			
			Normal Operation		Abnormal Operation	
	°C	°F	°C	°F	°C	°F
E	200	392	200	392	200	392
F	200	392	150	302	200	392
G	165	329	120	248	165	329

(E) Threading. The supply connection entry thread form shall be NPT or metric. Conduit and fittings shall be made wrenchtight to prevent sparking when fault current flows through the conduit system, and to ensure the explosionproof integrity of the conduit system where applicable. Equipment provided with threaded entries for field wiring connections shall be installed in accordance with 500.8(E)(1) or (E)(2) and with (E)(3).

(1) Equipment Provided with Threaded Entries for NPT Threaded Conduit or Fittings. For equipment provided with threaded entries for NPT-threaded conduit or fittings, listed conduit, listed conduit fittings, or listed cable fittings shall be used. All NPT-threaded conduit and fittings shall be threaded with a National (American) Standard Pipe Taper (NPT) thread.

This section clarifies that not only is the conduit required to be “listed” but also the conduit fittings and cable fittings.

NPT threaded entries into explosionproof equipment shall be made up with at least five threads fully engaged.

When using NPT entries it is important that these threads be installed wrenchtight. There is no clear definition for the term wrenchtight, however a good rule of thumb is handtight with no less than ¼ additional turn with a wrench. This is important to ensure that the roots and crests of the threads are fully engage and therefore create a sound flamepath as well as a secure mechanical and electrical grounding joint.

Exception: For listed explosionproof equipment, joints with factory-threaded NPT entries shall be made up with at least four and one-half threads fully engaged.

This exception is to recognize that factory produced threads provide for better control of thread specification tolerances and that the resulting threading engagement is adequate to perform the function of an explosionproof joint.

Informational Note No. 1: Thread specifications for male NPT threads are located in ANSI/ASME B1.20.1-1983, *Pipe Threads, General Purpose (Inch)*.

Informational Note No. 2: Female NPT-threaded entries use a modified National Standard Pipe Taper (NPT) thread with thread form per ANSI/ASME B1.20.1-1983, *Pipe Threads, General Purpose (Inch)*. See ANSI/UL 1203-2009, *Explosionproof and Dust-Ignition-Proof Electrical Equipment for Use in Hazardous (Classified) Locations*.

(2) Equipment Provided with Threaded Entries for Metric Threaded Conduit or Fittings. For equipment with metric threaded entries, listed conduit fittings or listed cable fittings shall be used. Such entries shall be identified as being metric, or listed adapters to permit connection to conduit or NPT threaded fittings shall be provided with the equipment and shall be used for connection to conduit or NPT threaded fittings.

Metric threaded entries into explosionproof equipment shall have a class of fit of at least 6g/6H and shall be made up with at least five threads fully engaged for Group C and group D, and at least eight threads fully engaged for Group A and Group B.

These threads must be identified to prevent improper assembly of fittings that do not employ metric threaded hubs.

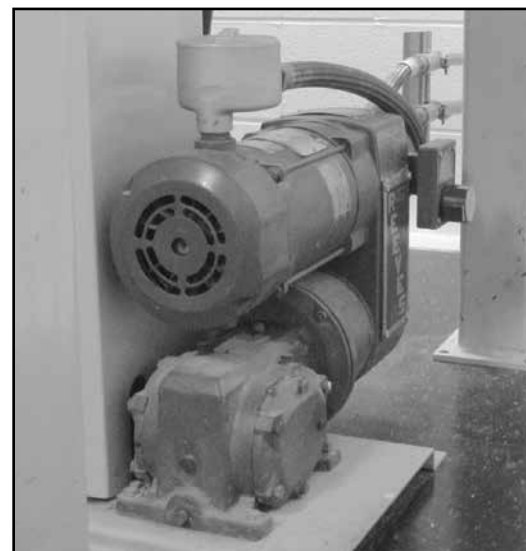

TYPICAL CLASS I, DIVISION 1 WIRING.

Informational Note: Threading specifications for metric threaded entries are located in ISO 9651-1998, *ISO general purpose metric screw threads – Tolerances – Part 1: Principles and basic data*, and ISO 965-3-1998, *ISO general purpose metric screw threads – Tolerances – Part 3: Deviations for constructional screw threads*.

INTERPRETATION OF ARTICLE 500: HAZARDOUS (CLASSIFIED) LOCATIONS, CLASSES I, II, AND III, DIVISIONS 1 AND 2

(3) Unused Openings. All unused openings shall be closed with listed metal close-up plugs. The plug engagement shall comply with 500.8(E)(1) or (E)(2).

(F) Optical Fiber Cables. Where an optical fiber cable contains conductors that are capable of carrying current, (composite optical fiber cable), the optical fiber cable shall be installed in accordance with the requirements of Articles 500, 501, 502, or 503, as applicable.

500.9 Specific Occupancies. Articles 510 through 517 cover garages, aircraft hangars, motor fuel dispensing facilities, bulk storage plants, spray application, dipping and coating processes, and health care facilities.

INTERPRETATION OF ARTICLE 501: CLASS I LOCATIONS

CHANGES TO ARTICLE 501

The following Article 501 sections have been revised during the 2014 *NEC*® Code cycle. These changes are those that are substantive and should be noted. This list does not include those changes that are editorial in nature.

Underlined text indicates a section that has been revised from the previous *NEC*® edition. It is not intended to indicate legislation text detailing the word-for-word revisions to the section. Where minor revisions have been made to a section, these will include underlined text for select words to indicate the minor revision.

- **Section 501.10(A)(1)(e)(New)**
Wiring Methods. Class I, Division 1. General. Fiber Optic Cables
- **Section 501.10(A)(2)**
Wiring methods. Class I, Division 1. Flexible Connections. Cord Connectors
- **Section 501.10(A)(2)(c)**
Wiring Methods. Class I, Division 1. Flexible Connections. TC-ER-HL Cable
- **Section 501.10(A)(3)**
Wiring Methods. Class I, Division 1. Boxes and Fittings. Informational Note
- **Section 501.10(B)(1)(5)**
Wiring Methods. Class I, Division 2. General. Type TC-ER
- **Section 501.10(B)(1)(7)**
Wiring Methods. Class I, Division 2. General. Optical Fiber Cable
- **Section 501.10(B)(2)(3)**
Wiring Methods. Class I, Division 2. Flexible Connections. Interlocked Armor Type MC Cable
- **Section 501.10(B)(2)(7)**
Wiring Methods. Class I, Division 2. Flexible Connections. Elevator Cable
- **Section 501.10(B)(4)**
Wiring Methods. Class I, Division 2. Boxes and Fittings
- **Section 501.15(B)(2)**
Sealing and Drainage. Conduit Seals, Class I, Division Boundary. Informational Note
- **Section 501.15(C)(6)**
Sealing and Drainage. Class I, Divisions 1 and 2. Conductor or Optical Fiber Fill
- **Section 501.17(4)**
Process Sealing. Secondary Seal
- **Section 501.105(B)(6)(1)**
Meters, Instruments, and Relays. Class I, Division 2. Connections. Switch

- **Section 501.125(B)**
Motors and Generators. Class I, Division 2
- **Section 501.130(B)(4)**
Luminaires. Class I, Division 2. Portable Lighting Equipment
- **Section 501.140(A)**
Flexible Cords, Class I, Divisions 1 and 2. Permitted Uses

I. General

501.1 Scope. Article 501 covers the requirements for electrical and electronic equipment and wiring for all voltages in Class I, Division 1 and 2 locations where fire or explosion hazards may exist due to flammable gases or vapors or flammable liquids.

Informational Note: For the requirements for electrical and electronic equipment and wiring for all voltages in Zone 0, Zone 1, or Zone 2 hazardous (classified) locations where fire or explosion hazards may exist due to flammable gases or vapors or flammable liquids, refer to Article 505.

The general rules in *NEC*® chapters one through four apply to the electronic wiring and equipment in locations classified as Class I unless modified by Article 501.

The rules in Article 500 also apply to Article 501.

Equipment listed and marked in accordance with Section 505.9(C)(2) for use in Class I, Zone 0, 1, or 2 locations is permitted in Class I, Division 2 locations for the same gas and with a suitable temperature class. Equipment listed and marked in accordance with Section 505.9(C)(2) for use in Class I, Zone 0 locations is permitted in Class I, Division 1 or Division 2 locations for the same gas with a suitable temperature class.

Note: See Article 505 for the requirements for installing electrical and electronic equipment and wiring for all voltages in Class I, Zone 0, Zone 1, or Zone 2 hazardous (classified) locations.

501.5 Zone Equipment. Equipment listed and marked in accordance with 505.9(C)(2) for use in Zone 0, 1, or 2 locations shall be permitted in Class I, Division 2 locations for the same gas and with a suitable temperature class. Equipment listed and marked in accordance with 505.9(C)(2) for use in Zone 0 locations shall be permitted in Class I, Division 1 or Division 2 locations for the same gas and with a suitable temperature class.



AJBEW CAST JUNCTION BOX



POWERPLEX PANELBOARD

INTERPRETATION OF ARTICLE 501: CLASS I LOCATIONS

II. Wiring

501.10 Wiring Methods. Wiring methods shall comply with 501.10(A) or (B).

Class I, Division 1 wiring methods include threaded rigid metal conduit (RMC) or threaded steel intermediate metal conduit (IMC), type M.I. cable, type MC-HL cable, or type ITC-HL cable, optical fiber cables, or rigid nonmetallic conduit (RNC).

(A) Class I, Division 1.

(1) General. In Class I, Division 1 locations, the wiring methods in (a) through (e) shall be permitted.

(a) Threaded rigid metal conduit or threaded steel intermediate metal conduit.

Threaded conduit entries that are made in the field must have at least five threads fully engaged while those made by the manufacturer must have at least 4 and one half threads fully engaged. This takes into consideration that factory produced threads are typically of precision quality due to the tooling and corresponding production control.

Exception: Type PVC conduit and Type RTRC conduit shall be permitted where encased in a concrete envelope a minimum of 50 mm (2 in.) thick and provided with not less than 600 mm (24 in.) of cover measured from the top of the conduit to grade. The concrete encasement shall be permitted to be omitted where subject to the provisions of 514.8, Exception No. 2, and 515.8(A). Threaded rigid metal conduit or threaded steel intermediate metal conduit shall be used for the last 600 mm (24 in.) of the underground run to emergence or to the point of connection to the aboveground raceway. An equipment grounding conductor shall be included to provide for electrical continuity of the raceway system and for grounding of non-current-carrying metal parts.

PVC conduit and RTRC conduit are permitted where encased in a concrete envelope a minimum of 50 mm (2 in.) thick and provided with not less than 600 mm (24 in.) of cover measured from the top of the conduit to grade. The concrete encasement can be omitted where the provisions of Section 514.8, Exception No. 2; and Section 515.8(A) are complied with. Threaded rigid metal conduit (RMC) or threaded steel intermediate metal conduit (IMC) is required the last 600 mm (24 in.) of the underground run to emergence or to the point of connection to the above ground raceway. An equipment grounding conductor must be installed in accordance with Section 352.60 or 355.60.

(b) Type MI cable terminated with fittings listed for the location. Type MI cable shall be installed and supported in a manner to avoid tensile stress at the termination fittings.

Type MI cable must be terminated with fittings listed for the location. Type MI cable shall be installed and supported in a manner to avoid tensile stress at the termination fittings. (See section 332.12 for restrictions on the use of type MI cable)

(c) In industrial establishments with restricted public access, where the conditions of maintenance and supervision ensure that only qualified persons service the installation, Type MC-HL cable listed for use in Class I, Zone 1 or Division 1 locations, with a gas/vaportight continuous corrugated metallic sheath, an overall jacket of suitable polymeric material, and a separate equipment grounding conductor(s) in accordance with 250.122, and terminated with fittings listed for the application.

Type MC-HL cable shall be installed in accordance with the provisions of Article 330, Part II.

MC-HL cable is permitted in industrial establishments with restricted public access, where the conditions of maintenance and supervision ensure that only qualified persons service the installation. The type MC-HL cable must be listed for use in Class I, Division 1 locations. It must have a gas/vaportight continuous corrugated metallic sheath, an overall jacket of suitable polymeric material, separate grounding conductors in accordance with 250.122, and terminated with fittings listed for the application. (See section 330.12 for restrictions on the use of type MC cable). This section also requires that the installation methods for MC cable are to be followed when installing MC-HL cable.

SHOWN BELOW ARE JUST A FEW OF THE MANY PRODUCTS SUITABLE FOR USE IN CLASS I, DIVISION 1 AREAS. THESE PRODUCTS MUST BE EXPLOSIONPROOF AND ALL THREADED JOINTS MUST HAVE AT LEAST FIVE THREADS FULLY ENGAGED, EXCEPT FOR LISTED EXPLOSIONPROOF EQUIPMENT, IN WHICH 4-1/2 THREADS FULLY ENGAGED FOR FACTORY THREADED NPT ENTRIES ARE ACCEPTABLE.

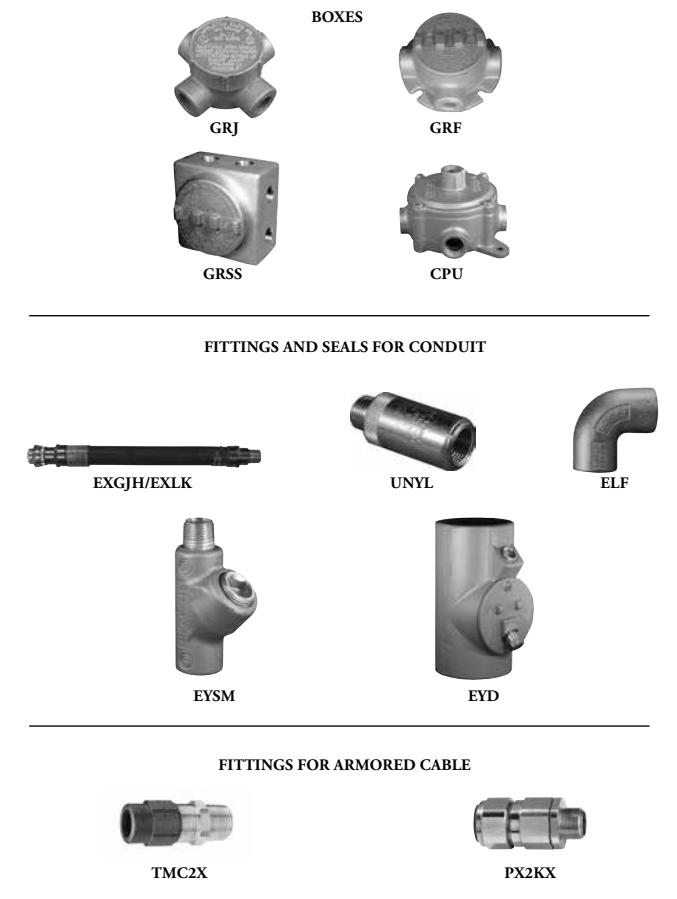

(d) In industrial establishments with restricted public access, where the conditions of maintenance and supervision ensure that only qualified persons service the installation, Type ITC-HL cable listed for use in Class I, Zone 1 or Division 1 locations, with a gas/vaportight continuous corrugated metallic sheath and an overall jacket of suitable polymeric material, and terminated with fittings listed for the application, and installed in accordance with the provisions of Article 727.

INTERPRETATION OF ARTICLE 501: CLASS I LOCATIONS

Type ITC-HL cable is permitted in industrial establishments with restricted public access, where the conditions of maintenance and supervision ensure that only qualified persons service the installation. The type ITC-HL cable must be listed for use in Class I, Division 1 locations. It must have a gas/vaportight continuous corrugated metallic sheath, an overall jacket of suitable polymeric material, and terminated with fittings listed for the application. (See section 727.5 for restrictions on the use of Type ITC-HL cable). Installation methods for ITC cable are to be followed when installing ITC-HL cable. The construction of ITC-HL is similar to that of MC-HL cables. The difference is the conductors and quantities contained in the cable. Connectors that are listed for MC-HL cable are suitable for use with ITC-HL cable based on the same cable diameters.

(e) Optical fiber cable Types OFNP, OFCP, OFNR, OFCR, OFNG, OFCG, OFN, and OFC shall be permitted to be installed in raceways in accordance with 501.10(A). These optical fiber cables shall be sealed in accordance with 501.15.

Section 770.3(A) permits the use of Listed optical fiber cables in Hazardous (Classified) Locations providing they are sealed in accordance with the requirements in Chapter 5. Subsection (e) has been added to ensure the specific requirements for sealing these cables are known.

(2) Flexible Connections. Where necessary to employ flexible connections, as at motor terminals, the following shall be permitted:

(1) Flexible fittings listed for the location, or

(2) Flexible cord in accordance with the provisions of 501.140, terminated with cord connectors listed for the location, or

Where flexible connections are necessary, flexible fittings listed for Class I, Division 1 locations (Appleton® EXGJH/EXLK). Flexible cord is permitted where terminated with cord connectors that are Listed for Class I, Division 1 or that are simply Listed for use with the specific cord where they are sealed in accordance with the requirements in Section 501.140. TC-ER-HL cable is permitted where the specific conditions in Subsection (3) are complied with.

(3) In industrial establishments with restricted public access, where the conditions of maintenance and supervision ensure that only qualified persons service the installation, for applications limited to 600 volts, nominal, or less, and where protected from damage by location or a suitable guard, listed Type TC-ER-HL cable with an overall jacket and a separate equipment grounding conductor(s) in accordance with 250.122 that is terminated with fittings listed for the location

Flexible fittings listed for the location have been the industry standard. These fittings are explosionproof and go through extensive testing to qualify for this application.

In lieu of these explosionproof “flexible” fittings, also allowed is portable cord for extra hard usage and now in *NEC*® 2014 type TC-ER-HL cable, a more robust type TC (Tray Cable). Both have additional installation requirements (special connectors, sealing, etc.), require protection from physical damage either by location or suitable guard and are restricted to industrial establishments to insure maintenance and engineering supervision. In addition portable cord for extra hard usage is allowed only where the required degree of movement provided by the portion of the circuit where the fixed wiring methods of 501.10(A) cannot provide the necessary degree of movement for fixed and mobile electrical utilization equipment.

(3) Boxes and Fittings. All boxes and fittings shall be approved for Class I, Division 1.

*Informational Note: For entry into enclosures required to be explosionproof, see the information on construction, testing, and marking of cables, explosionproof cable fittings, and explosionproof cord connectors in ANSI/UL 2225-2011, *Cables and Cable-Fittings for Use in Hazardous (Classified) Locations*.*

All boxes, fittings, and joints must be approved for Class I, Division 1 applications. Unlike boxes and fittings that are permitted for installation in Class I, Division 2 locations, boxes and fittings specifically approved for Class I, Division 1 locations are marked with their Class and Division rating. In most cases they are also marked with their rated gas Groups. The product standard for conduit fittings is ANSI/UL 1203. The Informational Note also identifies the product standard for Cord and Cable Fittings. A product only marked with its rated Class and Division is rated for all gas Groups within that Class and Division. A product not marked with the Division is suitable for use in both Division 1 and Division 2.

(B) Class I, Division 2.

(1) General. In Class I, Division 2 locations, the following wiring methods shall be permitted:

(1) All wiring methods permitted in 501.10(A).

(2) Enclosed gasketed busways and enclosed gasketed wireways.

(3) Type PLTC and Type PLTC-ER cable in accordance with the provisions of Article 725, including installation in cable tray systems. The cable shall be terminated with listed fittings.

(4) Type ITC and Type ITC-ER cable as permitted in 727.4 and terminated with listed fittings.

(5) Type MC, MV, TC, or TC-ER cable, including installation in cable tray systems. The cable shall be terminated with listed fittings.

Type TC-ER cable has been added as a permissible wiring method for Class I, Division 2 locations as other extended run cables had been permitted such as PLTC-ER and ITC-ER which are all constructed to the same strength requirements.



TYPICAL CLASS I, DIVISION 2 RIGID CONDUIT INSTALLATION.

(6) In industrial establishments with restricted public access, where the conditions of maintenance and supervision ensure that only qualified persons service the installation and where metallic conduit does not provide sufficient corrosion resistance, listed reinforced thermosetting resin conduit (RTRC), factory elbows, and associated fittings, all

INTERPRETATION OF ARTICLE 501: CLASS I LOCATIONS

marked with the suffix -XW, and Schedule 80 PVC conduit, factory elbows, and associated fittings shall be permitted.

Where seals are required for boundary conditions as defined in 501.15(A)(4), the Division 1 wiring method shall extend into the Division 2 area to the seal, which shall be located on the Division 2 side of the Division 1–Division 2 boundary.

Type RTRC-XW conduit and Schedule 80 PVC conduit are only permitted where the AHJ considers other conduit types do not provide sufficient corrosion resistance.

(7) Optical fiber cable Types OFNP, OFCP, OFNR, OFCR, OFNG, OFCG, OFN, and OFC shall be permitted to be installed in cable trays or any other raceway in accordance with 501.10(B). Optical fiber cables shall be sealed in accordance with 501.15.

Optical fiber cable of the types listed in Subsection (7) has been added as a permissible wiring method for Class I, Division 2 locations.

(2) Flexible Connections. Where provision must be made for flexibility, one or more of the following shall be permitted:

- (1) Listed flexible metal fittings.
- (2) Flexible metal conduit with listed fittings.
- (3) Interlocked armor Type MC cable with listed fittings.
- (4) Liquidtight flexible metal conduit with listed fittings.
- (5) Liquidtight flexible nonmetallic conduit with listed fittings.
- (6) Flexible cord listed for extra-hard usage and terminated with listed fittings. A conductor for use as an equipment grounding conductor shall be included in the flexible cord.
- (7) For elevator use, an identified elevator cable of Type EO, ETP, or ETT, shown under the “use” column in Table 400.4 for “hazardous (classified) locations” and terminated with listed fittings.

Informational Note: See 501.30(B) for grounding requirements where flexible conduit is used.

Where flexibility is needed Flexible Metal Fittings, Flexible Metal Conduit with listed fittings, Liquidtight Flexible Metal Conduit with listed fittings, Liquidtight Flexible Nonmetallic Conduit with listed fittings, or flexible cord listed for extra-hard usage and terminated with listed fittings shall be used. Type MC cable with interlocked armor is now permitted. In addition, Type EO, ETP, or ETT are now permitted for elevator use. The fittings for these permitted cables are not required to be listed “for the location”, as there are no product standards for Class I, Division 2 fittings. This means that the fitting is required to be listed for use with the specific type of conduit or for use with cord. An additional conductor for grounding shall be included in the flexible cord. Refer to 501.30(B) for additional requirements for bonding and grounding of flexible conduit.

(3) Nonincendive Field Wiring. Nonincendive field wiring shall be permitted using any of the wiring methods permitted for unclassified locations. Nonincendive field wiring systems shall be installed in accordance with the control drawing(s). Simple apparatus, not shown on the control drawing, shall be permitted in a nonincendive field wiring circuit, provided the simple apparatus does not interconnect the nonincendive field wiring circuit to any other circuit.

ON THIS PAGE ARE JUST A FEW OF THE MANY PRODUCTS SUITABLE FOR USE IN CLASS I, DIVISION 2 AREAS. PRODUCTS FOR DIVISION 2 NEED NOT BE EXPLOSIONPROOF, EXCEPT AS NOTED IN NEC 501.10(B)(4)

CONDUIT BODIES



FORM 35



FM7



MOGUL



FM8

BOXES



JB



GSU



PTB

CONNECTORS FOR CABLE/CORD



TMC2



CG



ST W/GROUND LUG

Informational Note: Simple apparatus is defined in 504.2.

Separate nonincendive field wiring circuits shall be installed in accordance with one of the following:

INTERPRETATION OF ARTICLE 501: CLASS I LOCATIONS

- (1) In separate cables
- (2) In multiconductor cables where the conductors of each circuit are within a grounded metal shield
- (3) In multiconductor cables or in raceways, where the conductors of each circuit have insulation with a minimum thickness of 0.25 mm (0.01 in.)

Nonincendive field wiring is permitted using any of the methods suitable for wiring in unclassified locations. However, it must be installed in accordance with the control drawing(s). Simple apparatus as defined in Section 504.2, not shown on the control drawing is permitted in a nonincendive field wiring circuit, provided the simple apparatus does not interconnect the nonincendive field wiring circuit to any other circuit.

Separate nonincendive field wiring circuits are permitted to be installed in separate cables, in multiconductor cables that employ conductors in for each circuit in a separate metal shield, or in multiconductor cables that employ circuit conductors that each has a minimum insulation thickness of 0.25 mm (0.01 in.).

(4) Boxes and Fittings. Boxes and fittings shall not be required to be explosionproof except as required by 501.105(B)(1), 501.115(B)(1), and 501.150(B)(1).

These referenced sections essentially describe equipment that employs arcing and sparking contacts.

Informational Note: For entry into enclosures required to be explosionproof, see the information on construction, testing, and marking of cables, explosionproof cable fittings, and explosionproof cord connectors in ANSI/UL 2225-2011, *Cables and Cable-Fittings for Use in Hazardous (Classified) Locations*.

TMC2 Series is suitable for use with MC cable when installed in accordance with Sections 501.10(B) and 501.15(E). Also suitable for use with type TC Tray Cable when installed in accordance with Section 501.10(B).

501.15 Sealing and Drainage. Seals in conduit and cable systems shall comply with 501.15(A) through (F). Sealing compound shall be used in Type MI cable termination fittings to exclude moisture and other fluids from the cable insulation.

Informational Note No. 1: Seals are provided in conduit and cable systems to minimize the passage of gases and vapors and prevent the passage of flames from one portion of the electrical installation to another through the conduit. Such communication through Type MI cable is inherently prevented by construction of the cable. Unless specifically designed and tested for the purpose, conduit and cable seals are not intended to prevent the passage of liquids, gases, or vapors at a continuous pressure differential across the seal. Even at differences in pressure across the seal equivalent to a few inches of water, there may be a slow passage of gas or vapor through a seal and through conductors passing through the seal. Temperature extremes and highly corrosive liquids and vapors can affect the ability of seals to perform their intended function.

Informational Note No. 2: Gas or vapor leakage and propagation of flames may occur through the interstices between the strands of standard stranded conductors larger than 2 AWG. Special conductor constructions, such as compacted strands or sealing of the individual strands, are means of reducing leakage and preventing the propagation of flames.

PURPOSE OF SEALING FITTINGS.

Conduit and cable seals are not intended to prevent the passage of liquids, gases or vapors through the conduit system.

TYPICAL SEAL APPLICATIONS

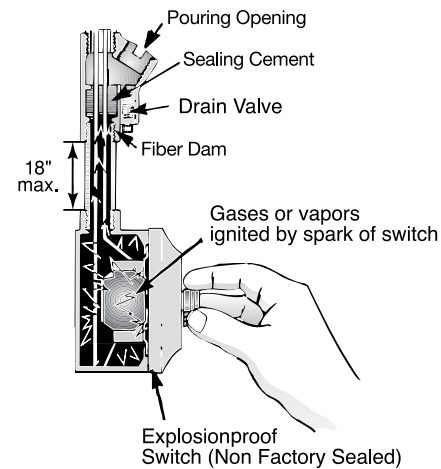
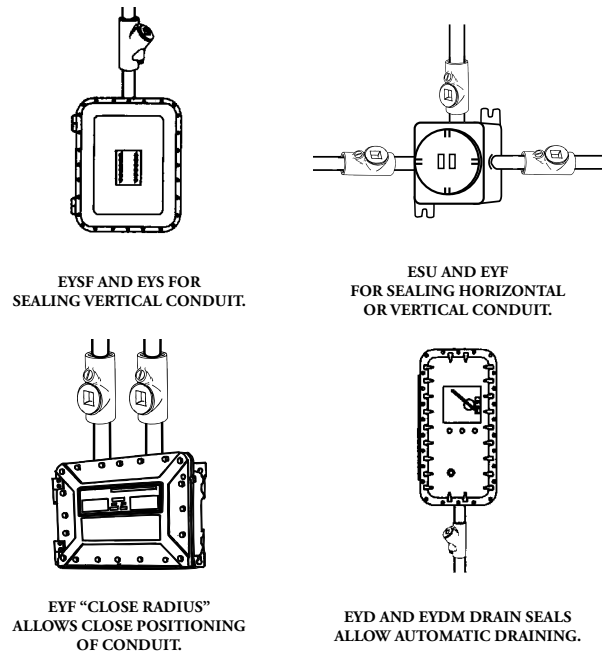

SEALS REQUIRED IN EACH CONDUIT WITHIN 18" OF ARC-PRODUCING DEVICE.

Seals are only intended to minimize the passage of vapors or gases and prevent passage of flames through the conduit system. Because sealing compound is somewhat porous, gases and vapors do get through it or can be transmitted through the air spaces between strands of stranded conductors. However, with only normal atmospheric pressure, the passage of gases or vapors through a seal is not sufficient to cause a hazardous condition.

Recognizing that standard sealing fittings do not completely prevent the passage of gases and vapors through the conduit system should create an increased awareness of the importance of sealing fittings,

INTERPRETATION OF ARTICLE 501: CLASS I LOCATIONS

particularly in their use in reducing “pressure piling,” an increasing pressure buildup along an entire conduit system as a result of explosions traveling through the system. The use of additional seals, in excess of Code requirements, will reduce this pressure and provide an extra margin of safety, especially important where the gas or vapor concentration is present continuously and at a dangerous level.

The propagation of flames and leakage of gases and vapors can occur through the interstices between the strands of standard stranded conductors in conductor sizes No. 2 AWG and larger. Sealing of individual strands or the use of compacted strands are proposed as means of dealing with this hazardous situation.

Appleton® sealing fittings are suitable for Class I and II locations.

EYS and EYD are for sealing vertical conduit. EY and ESU are for sealing vertical and horizontal conduit. EYDM and EYD also have drain valves.

(A) Conduit Seals, Class I, Division 1. In Class I, Division 1 locations, conduit seals shall be located in accordance with 501.15(A) (1) through (A)(4).

(1) Entering Enclosures. Each conduit entry into an explosionproof enclosure shall have a conduit seal where either of the following conditions applies:

(1) The enclosure contains apparatus, such as switches, circuit breakers, fuses, relays, or resistors, that may produce arcs, sparks, or temperatures that exceed 80 percent of the autoignition temperature, in degrees Celsius, of the gas or vapor involved in normal operation.

Exception: Seals shall not be required for conduit entering an enclosure under any one of the following conditions:

a. The switch, circuit breaker, fuse, relay, or resistor is enclosed within a chamber hermetically sealed against the entrance of gases or vapors.

b. The switch, circuit breaker, fuse, relay, or resistor is immersed in oil in accordance with 501.115(B)(1)(2).

c. The switch, circuit breaker, fuse, relay, or resistor is enclosed within a factory-sealed explosionproof chamber located within the enclosure, identified for the location, and marked “factory sealed” or equivalent.

d. The switch, circuit breaker, fuse, relay, or resistor is part of a nonincendive circuit.

Such apparatus may cause an ignition of gases or vapors that have migrated into the explosionproof enclosure. Under such an occurrence, the conduit seal will prevent the explosion and resulting flame front from propagating down the conduit system.

(2) The entry is metric designator 53 (trade size 2) or larger, and the enclosure contains terminals, splices, or taps.

This serves as an additional precaution for larger conduit systems. As these systems can be expected to contain greater gas migrations, the requirement for arcing and sparking apparatus in an explosionproof enclosure is expanded here to include containment of terminals, splices, or taps. This applies only when the conduit metric designator is 53 (2 trade size) or larger.

Factory-sealed enclosures shall not be considered to serve as a seal for another adjacent explosionproof enclosure that is required to

have a conduit seal.

External field-installed seals are NOT required if current-interrupting contacts are internally sealed in such a manner that arcs or sparks are not created within the enclosure leading to the conduit system (trade size 1-1/2 or smaller). The Appleton® General Catalog refers to such equipment as “factory sealed.”

Conduit seals shall be installed within 450 mm (18 in.) from the enclosure. Only explosionproof unions, couplings, reducers, elbows, capped elbows, and conduit bodies similar to L, T, and Cross types that are not larger than the trade size of the conduit shall be permitted between the sealing fitting and the explosionproof enclosure.

(2) Pressurized Enclosures. Conduit seals shall be installed within 450 mm (18 in.) of the enclosure in each conduit entry into a pressurized enclosure where the conduit is not pressurized as part of the protection system.

Informational Note No. 1: Installing the seal as close as possible to the enclosure will reduce problems with purging the dead airspace in the pressurized conduit.

Informational Note No. 2: For further information, see NFPA 496-2013, *Standard for Purged and Pressurized Enclosures for Electrical Equipment*.

(3) Two or More Explosionproof Enclosures. Where two or more explosionproof enclosures that require conduit seals are connected by nipples or runs of conduit not more than 900 mm (36 in.) long, a single conduit seal in each such nipple connection or run of conduit shall be considered sufficient if the seal is located not more than 450 mm (18 in.) from either enclosure.

(4) Class I, Division 1 Boundary. A conduit seal shall be required in each conduit run leaving a Division 1 location. The sealing fitting shall be permitted to be installed on either side of the boundary within 3.05 m (10 ft) of the boundary, and it shall be designed and installed to minimize the amount of gas or vapor within the portion of the conduit installed in the Division 1 location that can be communicated beyond the seal. The conduit run between the conduit seal and the point at which the conduit leaves the Division 1 location shall contain no union, coupling, box, or other fitting except for a listed explosionproof reducer installed at the conduit seal.

If the conduit seal is within 450mm (18 in.) of the enclosure on either side of the boundary and within 3.05 m (10 ft) of the boundary it shall serve as both a boundary and equipment seal.

Exception No. 1: Metal conduit that contains no unions, couplings, boxes, or fittings, that passes completely through a Division 1 location with no



INTERPRETATION OF ARTICLE 501: CLASS I LOCATIONS

fittings installed within 300 mm (12 in.) of either side of the boundary, shall not require a conduit seal if the termination points of the unbroken conduit are located in unclassified locations.

Exception No. 2: For underground conduit installed in accordance with 300.5 where the boundary is below grade, the sealing fitting shall be permitted to be installed after the conduit emerges from below grade, but there shall be no union, coupling, box, or fitting, other than listed explosionproof reducers at the sealing fitting, in the conduit between the sealing fitting and the point at which the conduit emerges from below grade.

The listed explosionproof reducers are not required to be provided with the sealing fitting by the sealing fitting manufacturer. Where listed explosionproof reducers are used they must be rated for the Group in which they are installed.

(B) Conduit Seals, Class I, Division 2. In Class I, Division 2 locations, conduit seals shall be located in accordance with 501.15(B)(1) and (B)(2).

(1) Entering Enclosures. For connections to enclosures that are required to be explosionproof, a conduit seal shall be provided in accordance with 501.15(A)(1)(1) and (A)(3). All portions of the conduit run or nipple between the seal and enclosure shall comply with 501.10(A).

(2) Class I, Division 2 Boundary. A conduit seal shall be required in each conduit run leaving a Class I, Division 2 location. The sealing fitting shall be permitted to be installed on either side of the boundary within 3.05 m (10 ft) of the boundary and it shall be designed and installed to minimize the amount of gas or vapor within the portion of the conduit installed in the Division 2 location that can be communicated beyond the seal. Rigid metal conduit or threaded steel intermediate metal conduit shall be used between the sealing fitting and the point at which the conduit leaves the Division 2 location, and a threaded connection shall be used at the sealing fitting. The conduit run between the conduit seal and the point at which the conduit leaves the Division 2 location shall contain no union, coupling, box, or other fitting except for a listed explosionproof reducer installed at the conduit seal. Such seals shall not be required to be explosionproof but shall be identified for the purpose of minimizing the passage of gases permitted under normal operating conditions and shall be accessible.

Informational Note: For further information, refer to ANSI/UL 514B-2012, Conduit, Tubing, and Cable Fittings.

The listed explosionproof reducers are not required to be provided with the sealing fitting by the sealing fitting manufacturer. Where listed explosionproof reducers are used they must be rated for the Group in which they are installed.

This boundary seal is not required to be approved for Class I, Division 1 (explosionproof) locations. Where a seal other than one approved for Class I, Division 1 (explosionproof) locations is used, it must be identified for the purpose of minimizing the passage of gases under normal operating conditions.

Informational Note provided to identify the product standard that contains requirements for seals that are unclassified.

Exception No. 1: Metal conduit that contains no unions, couplings, boxes, or fittings, that passes completely through a Division 2 location with no fittings installed within 300 mm (12 in.) of either side of the boundary, shall not be required to be sealed if the termination points of the unbroken conduit are located in unclassified locations.



SEAL FITTINGS (LEFT TO RIGHT): VERTICAL ONLY,

CLASS I, DIVISION 1 AND 2

Sealing fittings must be installed at boundary between a hazardous and non-hazardous area. Sealing fittings must also be installed at boundary between a Class I, Division 1 area and a Class I, Division 2 area.

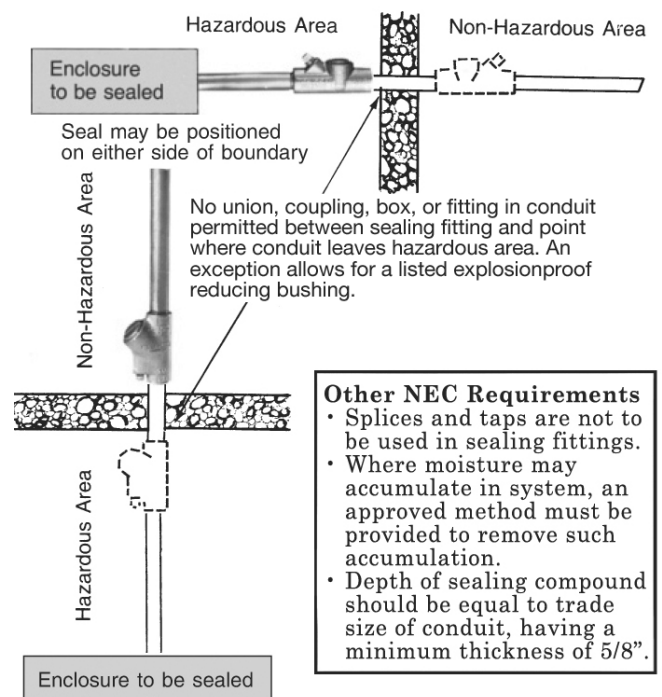

IMPORTANT NOTE: Where trade size of 2" or larger conduit is used with an enclosure required to be approved for Class I, Division 1, or at a boundary where any size conduit leaves a hazardous area to a non-hazardous area (or from Division 1 to Division 2), external seals must ALWAYS be used. However, external seals need not be placed within 18" of an enclosure containing an arcing device if the product is factory sealed for the specific Class and Group.

INTERPRETATION OF ARTICLE 501: CLASS I LOCATIONS

Exception No. 2: Conduit systems terminating in an unclassified location where the metal conduit transitions to cable tray, cablebus, ventilated busway, or Type MI cable, or to cable not installed in any cable tray or raceway system, shall not be required to be sealed where passing from the Division 2 location into the unclassified location under the following conditions:

(1) The unclassified location is outdoors located or the unclassified location is indoors and the conduit system is entirely in one room.

(2) The conduits shall not terminate at an enclosure containing an ignition source in normal operation.

Exception No. 3: Conduit systems passing from an enclosure or a room that is unclassified, as a result of pressurization, into a Division 2 location shall not require a seal at the boundary.

Informational Note: For further information, refer to NFPA 496-2013, *Standard for Purged and Pressurized Enclosures for Electrical Equipment*.

Exception No. 4: Segments of aboveground conduit systems shall not be required to be sealed where passing from a Division 2 location into an unclassified location if all of the following conditions are met:

(1) No part of the conduit system segment passes through a Division 1 location where the conduit segment contains unions, couplings, boxes, or fittings that are located within 300 mm (12 in.) of the Division 1 location.

(2) The conduit system segment is located entirely in outdoor locations.

(3) The conduit system segment is not directly connected to canned pumps, process or service connections for flow, pressure, or analysis measurement, and so forth, that depend on a single compression seal, diaphragm, or tube to prevent flammable or combustible fluids from entering the conduit system.

(4) The conduit system segment contains only threaded metal conduit, unions, couplings, conduit bodies, and fittings in the unclassified location.

(5) The conduit system segment is sealed at its entry to each enclosure or fitting located in the Division 2 location that contains terminals, splices, or taps.

(C) Class I, Divisions 1 and 2. Seals installed in Class I, Division 1 and Division 2 locations shall comply with 501.15(C)(1) through (C)(6).

Exception: Seals that are not required to be explosionproof by 501.15(B)(2) or 504.70 shall not be required to comply with 501.15(C).

(1) Fittings. Enclosures that contain connections or equipment shall be provided with an integral sealing means, or sealing fittings listed for the location shall be used. Sealing fittings shall be listed for use with one or more specific compounds and shall be accessible.

Sealing fitting compounds are not listed on their own merits. They are listed and evaluated for use with the sealing fittings. Some sealing fittings are listed with more than one sealing compound. Where this is the case, refer to the sealing fitting installation instructions for proper preparation of the sealing compound.

(2) Compound. The compound shall provide a seal to minimize the passage of gas and/or vapors through the sealing fitting and shall not be affected by the surrounding atmosphere or liquids. The melting point of the compound shall not be less than 93°C (200°F).

(3) Thickness of Compounds. The thickness of the sealing compound

installed in completed seals, other than listed cable sealing fittings, shall not be less than the metric designator (trade size) of the sealing fitting expressed in the units of measurement employed; however, in no case shall the thickness of the compound be less than 16 mm (5/8 in.).

(4) Splices and Taps. Splices and taps shall not be made in fittings intended only for sealing with compound; nor shall other fittings in which splices or taps are made be filled with compound.

(5) Assemblies. An entire assembly shall be identified for the location where the equipment that may produce arcs, sparks, or high temperatures is located in a compartment that is separate from the compartment containing splices or taps, and an integral seal is provided where conductors pass from one compartment to the other. In Division 1 locations, seals shall be provided in conduit connecting to the compartment containing splices or taps where required by 501.15(A)(1)(2).

(6) Conductor or Optical Fiber Fill. The cross-sectional area of the conductors or optical fiber tubes (metallic or nonmetallic) permitted in a seal shall not exceed 25 percent of the cross-sectional area of a rigid metal conduit of the same trade size unless the seal is specifically identified for a higher percentage of fill.

Conduit sealing fittings are available for expanded fill applications. These sealing fittings facilitate conduit fill applications up to 40% fill. Utilization of these seals can reduce the total number of conduit runs required by a given installation.

Appleton's EF series allows a maximum of 40% fill. These fittings are UL listed for Class I, Groups B,C, D, Class II Groups E,F,G and Class III locations.

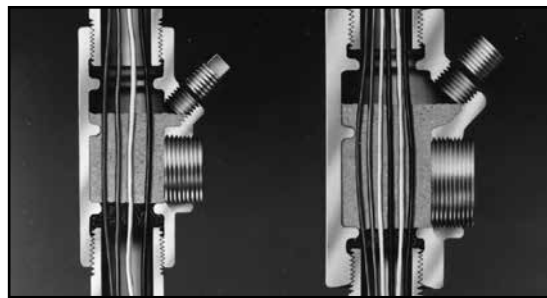

CUT-A-WAY VIEW COMPARISON OF 25% FILL SEAL (LEFT) VS 40% EXPANDED FILL (RIGHT) TO MEET 501.15(C)(6).

External seals are ALWAYS required in the following: **situation (1)** Class I, Division 1 areas where metric designator 53 (trade size 2) or larger conduit enters an enclosure (whether or not factory sealed or whether or not containing an arcing device); **situation (2)** in Class I, Division 1 or Class I, Division 2 areas where any size conduit enters an enclosure required to be approved for Class I, Division 1 (such as an enclosure with an arcing device); and **situation (3)** at a boundary where any size conduit leaves a hazardous area to an area of lesser hazard (see specific boundary situations below).

External seals are not required with an enclosure containing an arcing device if the product is factory sealed for the specific Class and Group [unless situations (1) and or (2) exist].

INTERPRETATION OF ARTICLE 501: CLASS I LOCATIONS

Note: In each conduit run passing from a Class I, Division 2 location into an unclassified location, the seal is not required to be rated as explosionproof.

(D) Cable Seals, Class I, Division 1. In Division 1 locations, cable seals shall be located according to 501.15(D)(1) through (D)(3).

(1) At Terminations. Cables shall be sealed with sealing fittings that comply with 501.15(C) at all terminations. Type MC-HL cables with a gas/vaportight continuous corrugated metallic sheath and an overall jacket of suitable polymeric material shall be sealed with a listed fitting after the jacket and any other covering have been removed so that the sealing compound can surround each individual insulated conductor in such a manner as to minimize the passage of gases and vapors.

Cable is required to be sealed at all terminations in a Class I, Division 1 location whether the enclosure contains arcing and sparking devices or not.

Exception: Shielded cables and twisted pair cables shall not require the removal of the shielding material or separation of the twisted pairs, provided the termination is sealed by an approved means to minimize the entrance of gases or vapors and prevent propagation of flame into the cable core.

This exception permits shielded cables and twisted pair cables without requiring the removal of the shielding material or separation of the twisted pairs within the seal fitting. The termination must be by an approved means to minimize the entrance of gases or vapors and prevent propagation of flame into the cable core. This exception recognizes that the removal of the cable shield for sealing individual conductors may cause electronic problems in some instrumentation circuits.



ES 25% FILL SEALING HUB WITH LOCKNUT AND SEALING GASKET OPTION

(2) Cables Capable of Transmitting Gases or Vapors. Cables with a gas/vaportight continuous sheath capable of transmitting gases or vapors through the cable core, installed in conduit, shall be sealed in the Class I, Division 1 location after the jacket and any other coverings have been removed so that the sealing compound can surround each individual insulated conductor or optical fiber tube and the outer jacket.

Sealing requirements for cable are the same as for those described for conduit plus the additional requirement that sealing compound must surround each individual conductor and the outer jacket.

Exception: Multiconductor cables with a gas/vaportight continuous sheath capable of transmitting gases or vapors through the cable core shall be permitted to be considered as a single conductor by sealing the cable in the conduit within 450 mm (18 in.) of the enclosure and the cable end within the enclosure by an approved means to minimize the entrance of gases or vapors and prevent the propagation of flame into the cable core, or by other approved methods. It shall not be required to remove the shielding material

or separate the twisted pairs of shielded cables and twisted pair cables.

This exception provides that a multiconductor cable need not have the outer jacket removed and sealing compound applied around each individual conductor in certain situations. The entire cable is permitted to be considered as if it were a single conductor. The sealing compound, therefore, need only be applied to the outer jacket, provided that an approved method is used to prevent the entrance of gases or vapors or propagation of flame into the cable core (possible method is the use of epoxy mastics if future laboratory investigations determine that it provides the necessary protection required by 501.15(D)(2)). The outer jacket of the cable in the conduit must be sealed within 18" of the enclosure.

(3) Cables Incapable of Transmitting Gases or Vapors. Each multiconductor cable installed in conduit shall be considered as a single conductor if the cable is incapable of transmitting gases or vapors through the cable core. These cables shall be sealed in accordance with 501.15(A).

Where cable is installed in conduit and is incapable of transmitting gases or vapors through the cable core, the sealing requirements are the same as those for conductors in conduit.

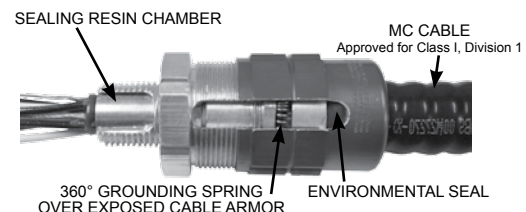

TMC2X SEALING CABLE FITTING APPROVED FOR CLASS I, DIVISION 1.

(E) Cable Seals, Class I, Division 2. In Division 2 locations, cable seals shall be located in accordance with 501.15(E)(1) through (E)(4).

Exception: Cables with an unbroken gas/vaportight continuous sheath shall be permitted to pass through a Division 2 location without seals.

This exception recognizes that cables with an unbroken gas/vaportight sheath are to be treated like conduit when passing through a Division 2 location.

(1) Terminations. Cables entering enclosures that are required to be explosionproof shall be sealed at the point of entrance. The sealing fitting shall comply with 501.15(B)(1) or be explosionproof. Multiconductor or optical multifiber cables with a gas/vaportight continuous sheath capable of transmitting gases or vapors through the cable core that are installed in a Division 2 location shall be sealed with a listed fitting after the jacket and any other coverings have been removed so that the sealing compound can surround each individual insulated conductor or optical fiber tube in such a manner as to minimize the passage of gases and vapors. Multiconductor or optical multifiber cables installed in conduit shall be sealed as described in 501.15(D).

Cables entering enclosures that are not required to be explosionproof are not required to be sealed at their terminations in a Class I, Division 2 location.

The sealing requirements for multiconductor cables in conduit are

INTERPRETATION OF ARTICLE 501: CLASS I LOCATIONS

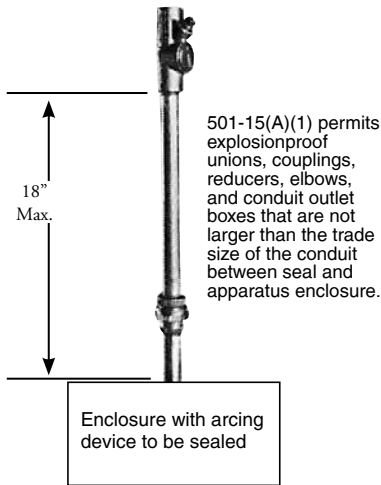

CLASS I, DIVISION 1 AND 2.

Seals must be placed in each conduit within 450 mm (18 in.) of a device that may produce arcs, sparks, or high temperatures.

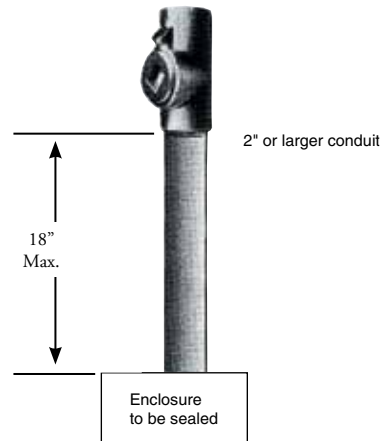

CLASS I, DIVISION 1.

Where metric designator 53 (trade size 2) or larger conduit enters an enclosure, seals are required within 450 mm (18 in.) of the enclosure. (Seals are not required on any trade size conduit in Class I, Division 2 areas unless the enclosure is required to be approved for Class I, Division 1.)

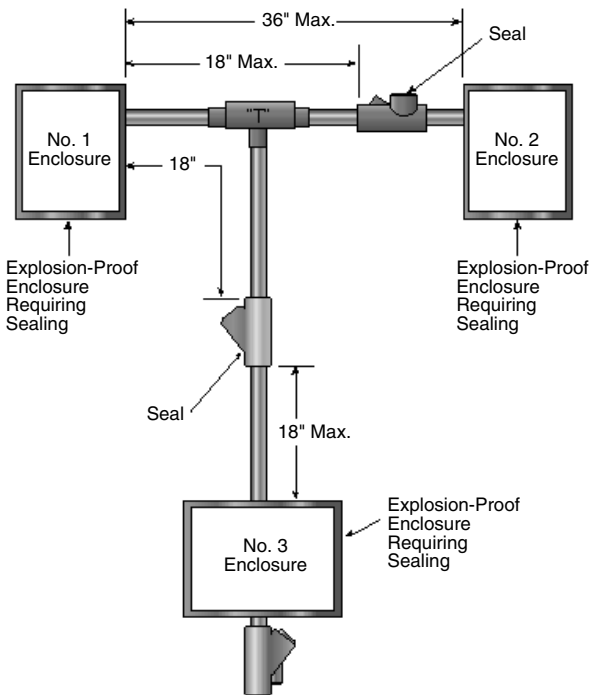

CLASS I, DIVISION 1.

In above, *NEC*[®] requires two seals so that the run of conduit between Enclosure No. 1 and Enclosure No. 2 is sealed. Even if Enclosure No. 3 were not required to be sealed, the seal in the vertical run of conduit to Enclosure No. 3 would be required to be sealed within 18 in. of Enclosure No. 1, because the vertical conduit run to the "T" fitting is a conduit run to Enclosure No. 1.

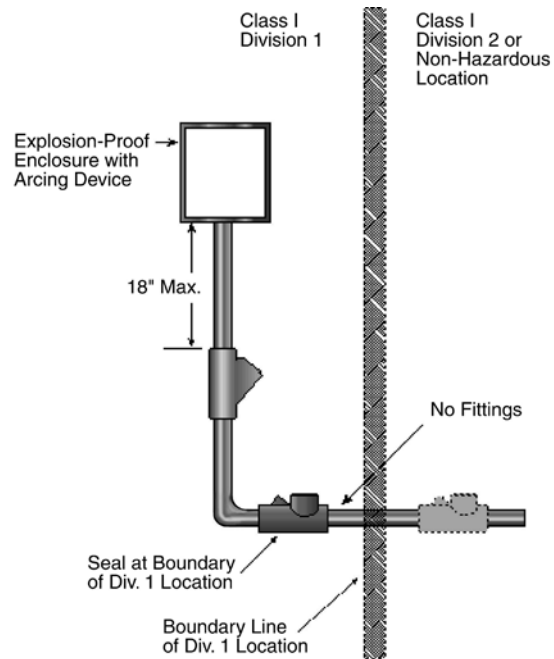

CLASS I, DIVISION 1.

NEC[®] requires seal at boundary of Class I, Division 1 location. The seal may be on either side of the boundary if there is no box, fitting, etc. between the boundary and the sealing fitting. It must be within 3.05 m (10 ft.) of either side of the boundary.

INTERPRETATION OF ARTICLE 501: CLASS I LOCATIONS

treated the same for Class I, Division 1 and Class I, Division 2 locations where they enter enclosures that are required to be explosionproof.

Exception No. 1: Cables leaving an enclosure or room that is unclassified as a result of Type Z pressurization and entering into a Division 2 location shall not require a seal at the boundary.

This exception permits cables that pass from an enclosure or room that is unclassified as a result of Type Z pressurization into a Class I, Division 2 location to not require a seal at the boundary.

Exception No. 2: Shielded cables and twisted pair cables shall not require the removal of the shielding material or separation of the twisted pairs, provided the termination is by an approved means to minimize the entrance of gases or vapors and prevent propagation of flame into the cable core.

This exception is the same as the exception in 501.15(D)(1) for shielded cables and twisted pair cables. Its purpose is to not require the removal of the shielding material or separation of the twisted pairs provided the termination is by an approved means. The termination must be by an approved means to minimize the entrance of gases or vapors and prevent propagation of flame into the cable core. This exception recognizes that the removal of the cable shield for sealing individual conductors may cause electronic problems in some instrumentation circuits.

(2) Cables That Do Not Transmit Gases or Vapors. Cables that have a gas/vaportight continuous sheath and do not transmit gases or vapors through the cable core in excess of the quantity permitted for seal fittings shall not be required to be sealed except as required in 501.15(E)(1). The minimum length of such a cable run shall not be less than the length needed to limit gas or vapor flow through the cable core, excluding the interstices of the conductor strands, to the rate permitted for seal fittings [200 cm³/hr (0.007 ft³/hr) of air at a pressure of 1500 pascals (6 in. of water)].

These types of cables are not required to be sealed in accordance with the same rules for Class I, Division 1 cable seals. They are however, required to be sealed at their terminations when entering enclosures that are required to be explosionproof in a Class I, Division 2 location.

As the described sealing characteristics of these cables are difficult to ascertain in the field, if there is any doubt as to the suitability of the cable to prevent the transmission of gases or vapors, the cable should be sealed according to 501(E)(3).

(3) Cables Capable of Transmitting Gases or Vapors. Cables with a gas/vaportight continuous sheath capable of transmitting gases or vapors through the cable core shall be sealed as required in 501.15(E)(1), unless the cable is attached to process equipment or devices that may cause a pressure in excess of 1500 pascals (6 in. of water) to be exerted at a cable end, in which case a seal, a barrier, or other means shall be provided to prevent migration of flammables into an unclassified location.

The requirements of this rule are essentially the same as Section 501.15(E)(2) with the additional requirement that if the cable is attached to certain process equipment that will result in additional pressure in the conduit system then a supplemental seal or barrier is required to prevent the migration of flammables into an unclassified area.

(4) Cables Without Gas/Vaportight Sheath. Cables that do not have a gas/vaportight continuous sheath shall be sealed at the boundary of the Division 2 and unclassified location in such a manner as to minimize the passage of gases or vapors into an unclassified location.

As gases and vapors are likely to penetrate through the interstices of the outer sheath it is required that these gases/vapors be prevented from migrating into an adjacent unclassified area. In the absence of being run in conduit where a conduit seal can be installed at the boundary, another option is to terminate and seal the cable into a Class I, Division 2 enclosure at the boundary of the Division 2 location. On the other side of this enclosure the cable could then be run through to the unclassified location with no additional seals required.

(F) Drainage.

(1) Control Equipment. Where there is a probability that liquid or other condensed vapor may be trapped within enclosures for control equipment or at any point in the raceway system, approved means shall be provided to prevent accumulation or to permit periodic draining of such liquid or condensed vapor.

(2) Motors and Generators. Where liquid or condensed vapor may accumulate within motors or generators, joints and conduit systems shall be arranged to minimize the entrance of liquid. If means to prevent accumulation or to permit periodic draining are necessary, such means shall be provided at the time of manufacture and shall be considered an integral part of the machine.

NEC® Sections 501.15(F)(1) and 501.15(F)(2) require that if condensed vapor may be trapped in the enclosure, an approved means must be provided to prevent such accumulation or to permit periodic draining.

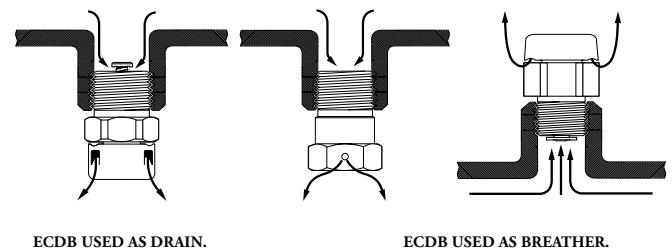

501.17 Process Sealing. This section shall apply to process-connected equipment, which includes, but is not limited to, canned pumps, submersible pumps, flow, pressure, temperature, or analysis measurement instruments. A process seal is a device to prevent the migration of process fluids from the designed containment into the external electrical system. Process-connected electrical equipment that incorporates a single process seal, such as a single compression seal, diaphragm, or tube to prevent flammable or combustible fluids from entering a conduit or cable system capable of transmitting fluids, shall be provided with an additional means to mitigate a single process seal failure. The additional means may include, but is not limited to, the following:

(1) A suitable barrier meeting the process temperature and pressure conditions that the barrier will be subjected to upon failure of the single process seal. There shall be a vent or drain between the single process seal and the suitable barrier. Indication of the single process seal failure shall be provided by visible leakage, an audible whistle, or other means of monitoring.

(2) A listed Type MI cable assembly, rated at not less than 125 percent of the process pressure and not less than 125 percent of the maximum

INTERPRETATION OF ARTICLE 501: CLASS I LOCATIONS

process temperature (in degrees Celsius), installed between the cable or conduit and the single process seal.

(3) A drain or vent located between the single process seal and a conduit or cable seal. The drain or vent shall be sufficiently sized to prevent overpressuring the conduit or cable seal above 6 in. water column (1493 Pa). Indication of the single process seal failure shall be provided by visible leakage, an audible whistle, or other means of monitoring.

(4) An add-on secondary seal marked “secondary seal” and rated for the pressure and temperature conditions to which it will be subjected upon failure of the single process seal.

Process-connected electrical equipment that does not rely on a single process seal or is listed and marked “single seal” or “dual seal” shall not be required to be provided with an additional means of sealing.

Informational Note: For construction and testing requirements for process sealing for listed and marked single seal, dual seal, or secondary seal equipment, refer to ANSI/ISA-12.27.01-2011, *Requirements for Process Sealing Between Electrical Systems and Flammable or Combustible Process Fluids*.

The section now recognizes secondary seal equipment as an acceptable means to mitigate a single process seal failure.

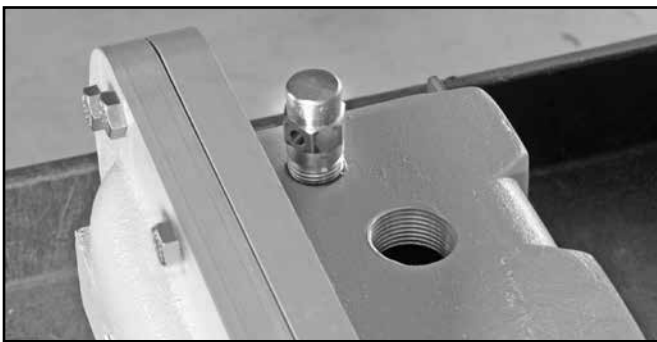

ECDB BREATHER INSTALLED IN TOP OF EXPLOSIONPROOF ENCLOSURE.

501.20 Conductor Insulation, Class I, Divisions 1 and 2. Where condensed vapors or liquids may collect on, or come in contact with, the insulation on conductors, such insulation shall be of a type identified for use under such conditions; or the insulation shall be protected by a sheath of lead or by other approved means.

501.25 Uninsulated Exposed Parts, Class I, Divisions 1 and 2. There shall be no uninsulated exposed parts, such as electrical conductors, buses, terminals, or components, that operate at more than 30 volts (15 volts in wet locations). These parts shall additionally be protected by a protection technique according to 500.7(E), (F), or (G) that is suitable for the location.

501.30 Grounding and Bonding, Class I, Divisions 1 and 2. Regardless of the voltage of the electrical system, wiring and equipment in Class I, Division 1 and 2 locations shall be grounded as specified in Article 250 and in accordance with the requirements of 501.30(A) and (B).

(A) Bonding. The locknut-bushing and double-locknut types of contacts shall not be depended on for bonding purposes, but bonding jumpers with proper fittings or other approved means of bonding shall be used. Such means of bonding shall apply to all intervening raceways, fittings, boxes, enclosures, and so forth between Class I locations and

the point of grounding for service equipment or point of grounding of a separately derived system.

Exception: The specific bonding means shall be required only to the nearest point where the grounded circuit conductor and the grounding electrode are connected together on the line side of the building or structure disconnecting means as specified in 250.32(B), provided the branchcircuit overcurrent protection is located on the load side of the disconnecting means.

The locknut-bushing and double-locknut types of contacts must not be used for bonding purposes. Bonding jumpers with proper fittings or other approved means of bonding must be used. These methods apply to all intervening raceways, fittings, boxes, enclosures, etc. between Class I locations and point of grounding for service equipment or separately derived system. These methods only apply to the point of grounding of a building disconnecting means in accordance with Sections 250.32(A), (B), and (C) where the branch circuit protective device is located on the load side of the disconnecting means.

(B) Types of Equipment Grounding Conductors. Flexible metal conduit and liquidtight flexible metal conduit shall include an equipment bonding jumper of the wire type in compliance with 250.102.

Exception: In Class I, Division 2 locations, the bonding jumper shall be permitted to be deleted where all of the following conditions are met:

- (1) Listed liquidtight flexible metal conduit 1.8 m (6 ft) or less in length, with fittings listed for grounding, is used.*
- (2) Overcurrent protection in the circuit is limited to 10 amperes or less.*
- (3) The load is not a power utilization load.*

NEC® Section 501.30(B) requires that liquidtight flexible metal conduit, as well as flexible metal conduit, be installed with internal or external bonding jumpers in parallel with each conduit if these conduits are “to be relied upon to complete a sole equipment grounding path.” The equipment bonding jumpers must comply with all other requirements of Section 250.102.

In Class I, Division 2 locations, the Exception permits the use of listed liquidtight flexible metal conduit 1.8 m (6 ft) or less in length if: (1) fittings listed for grounding are used; (2) the over-current protection in the circuit is limited to 10 amperes or less; and (3) circuit to a load is not a power utilization load.

501.35 Surge Protection.

(A) Class I, Division 1. Surge arresters, surge-protective devices, and capacitors shall be installed in enclosures identified for Class I, Division 1 locations. Surge-protective capacitors shall be of a type designed for specific duty.

Surge arresters, transient voltage suppressors (TVSS), and capacitors shall be installed in enclosures identified for Class I, Division 1 locations. These enclosures may be identified as Explosionproof or Purged and Pressurized.

(B) Class I, Division 2. Surge arresters and surgeprotective devices shall be nonarcing, such as metal-oxide varistor (MOV) sealed type, and surge-protective capacitors shall be of a type designed for specific duty. Enclosures shall be permitted to be of the general-purpose type. Surge protection of types other than described in this paragraph shall be installed in enclosures identified for Class I, Division 1 locations.

INTERPRETATION OF ARTICLE 501: CLASS I LOCATIONS

SELECTION OF SEALS.

VERTICAL — FOR SEALING VERTICAL CONDUIT



EYSM
1/2"–4"



EYS
1/2"–1"

SEALING HUBS — FOR CONDUIT RISERS IN CAST OR SHEET METAL ENCLOSURES



ES SERIES
1/2"–6"

FOR SEALING VERTICAL/HORIZONTAL CONDUIT



ESUF
1/2"–1"



EY — CLOSE TURNING RADIUS
1/2"–1" 1-1/4"–3" 3-1/2"–6"

DAMMING AND POURING: HORIZONTAL CONDUIT.
Sealing Compound

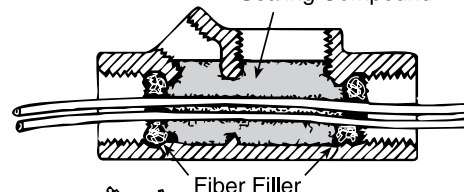

Fiber Filler

DRAIN SEALS—FOR VERTICAL CONDUIT



EYD — CLOSE TURNING RADIUS
1/2"–1" 1-1/4"–3" 3-1/2"–4"

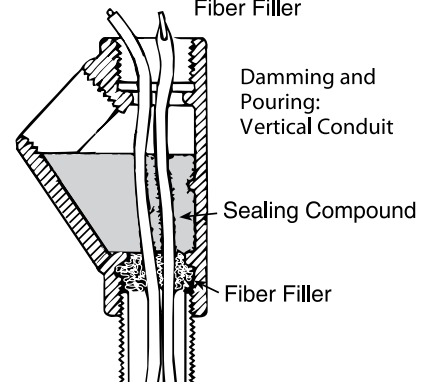

Damming and
Pouring:
Vertical Conduit

Sealing Compound

Fiber Filler

FOR VERTICAL CONDUIT — 40% CONDUIT FILL



EYS116
STANDARD



EYDEF
DRAIN



EYDEF
DRAIN

DAMMING AND POURING COMPOUNDS IN SEALING FITTINGS.



CONSTRUCT DAM IN HUB. TUCK FILLER AROUND EACH CONDUCTOR. CONDUCTORS SHOULD BE SEPARATED AND FIBER PACKED TIGHTLY AROUND THEM.

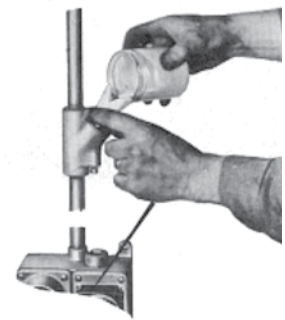

MIX KWIKO SEALING CEMENT THOROUGHLY IN A CLEAN CONTAINER. POUR DIRECTLY INTO THE SEALING FITTING. DEPTH OF SEALING COMPOUND SHOULD EQUAL TRADE SIZE OF CONDUIT, HAVING A MINIMUM OF 16 MM (5/8 IN.) THICKNESS.

INTERPRETATION OF ARTICLE 501: CLASS I LOCATIONS

RECEPTACLES AND PLUGS—CLASS I, DIVISION 1 AND 2.



U-LINE® 20 AMP



EBR — 30, 60, 100, AND 150 AMP



CPS 20 AMP



CPP 20 AMP PLUG

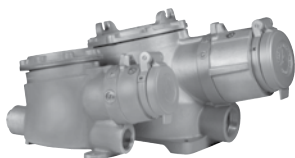

FSQC — 30, 60, 100 AMP



JBR — 30, 60 AMP

These enclosures are not required to be identified as Class I, Division 2 where they contain surge arresters and TVSS devices of the nonarcing type or where they contain surge-protective capacitors designated as special duty type. If they contain other surge protection types then the enclosure must be identified as Class I, Division 1.

III. Equipment

501.100 Transformers and Capacitors.

(A) **Class I, Division 1.** In Class I, Division 1 locations, transformers and capacitors shall comply with 501.100(A)(1) and (A)(2).

(1) **Containing Liquid That Will Burn.** Transformers and capacitors containing a liquid that will burn shall be installed only in vaults that comply with 450.41 through 450.48 and with (1) through (4) as follows:

(1) There shall be no door or other communicating opening between the vault and the Division 1 location.

(2) Ample ventilation shall be provided for the continuous removal of flammable gases or vapors.

(3) Vent openings or ducts shall lead to a safe location outside of buildings.

(4) Vent ducts and openings shall be of sufficient area to relieve explosion pressures within the vault, and all portions of vent ducts within the buildings shall be of reinforced concrete construction.

(2) **Not Containing Liquid That Will Burn.** Transformers and capacitors that do not contain a liquid that will burn shall be installed in vaults complying with 501.100(A)(1) or be identified for Class I locations.

(B) **Class I, Division 2.** In Class I, Division 2 locations, transformers shall comply with 450.21 through 450.27, and capacitors shall comply with 460.2 through 460.28.

Caution should be taken when selecting transformers being used in Class I, Division 2 locations due to the temperature rise of the transformer. Transformer maximum normal operating temperature could exceed Class I gas autoignition temperature(s). The use of lower temperature rise transformers can be an acceptable method to address this concern.

Transformers are typically designed to have a specific maximum temperature rise at a specific maximum ambient. Also in the design is an allowable maximum hot spot temperature above the temperature rise.

Transformer maximum operating temperature = Temperature rise + Hot Spot (at a given Ambient).

501.105 Meters, Instruments, and Relays.

(A) **Class I, Division 1.** In Class I, Division 1 locations, meters, instruments, and relays, including kilowatt-hour meters, instrument transformers, resistors, rectifiers, and thermionic tubes, shall be provided with enclosures identified for Class I, Division 1 locations. Enclosures for Class I, Division 1 locations include explosionproof enclosures and purged and pressurized enclosures.

Informational Note: See NFPA 496-2013, Standard for Purged and Pressurized Enclosures for Electrical Equipment.

INTERPRETATION OF ARTICLE 501: CLASS I LOCATIONS

(B) Class I, Division 2. In Class I, Division 2 locations, meters, instruments, and relays shall comply with 501.105(B)(1) through (B)(6).

(1) Contacts. Switches, circuit breakers, and make-and-break contacts of pushbuttons, relays, alarm bells, and horns shall have enclosures identified for Class I, Division 1 locations in accordance with 501.105(A).

Exception: General-purpose enclosures shall be permitted if current-interrupting contacts comply with one of the following:

(1) *Are immersed in oil*

(2) *Are enclosed within a chamber that is hermetically sealed against the entrance of gases or vapors*

(3) *Are in nonincendive circuits*

(4) *Are listed for Division 2*

(2) Resistors and Similar Equipment. Resistors, resistance devices, thermionic tubes, rectifiers, and similar equipment that are used in or in connection with meters, instruments, and relays shall comply with 501.105(A).

Exception: General-purpose-type enclosures shall be permitted if such equipment is without make-and-break or sliding contacts [other than as provided in 501.105(B)(1)] and if the maximum operating temperature of any exposed surface will not exceed 80 percent of the autoignition temperature in degrees Celsius of the gas or vapor involved or has been tested and found incapable of igniting the gas or vapor. This exception shall not apply to thermionic tubes.

(3) Without Make-or-Break Contacts. Transformer windings, impedance coils, solenoids, and other windings that do not incorporate sliding or make-or-break contacts shall be provided with enclosures. General-purpose-type enclosures shall be permitted.

(4) General-Purpose Assemblies. Where an assembly is made up of components for which general-purpose enclosures are acceptable as provided in 501.105(B)(1), (B)(2), and (B)(3), a single general-purpose enclosure shall be acceptable for the assembly. Where such an assembly includes any of the equipment described in 501.105(B)(2), the maximum obtainable surface temperature of any component of the assembly shall be clearly and permanently indicated on the outside of the enclosure. Alternatively, equipment shall be permitted to be marked to indicate the temperature class for which it is suitable, using the temperature class (T Code) of Table 500.8(C).

(5) Fuses. Where general-purpose enclosures are permitted in 501.105(B)(1) through (B)(4), fuses for overcurrent protection of instrument circuits not subject to overloading in normal use shall be permitted to be mounted in general purpose enclosures if each such fuse is preceded by a switch complying with 501.105(B)(1).

(6) Connections. To facilitate replacements, process control instruments shall be permitted to be connected through flexible cord, attachment plug, and receptacle, provided all of the following conditions apply:

(1) A switch complying with 501.105(B)(1) is provided so that the attachment plug is not depended on to interrupt current.

Exception: The switch is not required if the circuit is nonincendive field wiring.

This exception is intended to permit non-power circuits wired by other nonincendive means such as control cable and instrument cable.

(2) The current does not exceed 3 amperes at 120 volts, nominal.

(3) The power-supply cord does not exceed 900 mm (3 ft), is of a type listed for extra-hard usage or for hard usage if protected by location, and is supplied through an attachment plug and receptacle of the locking and grounding type.

(4) Only necessary receptacles are provided.

(5) The receptacle carries a label warning against unplugging under load.

501.115 Switches, Circuit Breakers, Motor Controllers, and Fuses.

These products contain arcing devices and must meet the requirements of 501.115(A) and (B) as applicable. All Appleton switches, circuit breakers and motor starters comply with this Section. Products are offered that are suitable for use in Class I, Division 1 and Class I, Division 2 locations.

(A) Class I, Division 1. In Class I, Division 1 locations, switches, circuit breakers, motor controllers, and fuses, including pushbuttons, relays, and similar devices, shall be provided with enclosures, and the enclosure in each case, together with the enclosed apparatus, shall be identified as a complete assembly for use in Class I locations.

(B) Class I, Division 2. Switches, circuit breakers, motor controllers, and fuses in Class I, Division 2 locations shall comply with 501.115(B) (1) through (B)(4).

(1) Type Required. Circuit breakers, motor controllers, and switches intended to interrupt current in the normal performance of the function for which they are installed shall be provided with enclosures identified for Class I, Division 1 locations in accordance with 501.105(A), unless general-purpose enclosures are provided and any of the following apply:

(1) The interruption of current occurs within a chamber hermetically sealed against the entrance of gases and vapors.

This method prevents the source gas or vapor from gaining access into the device where the interruption of current is to occur.

(2) The current make-and-break contacts are oil-immersed and of the general-purpose type having a 50-mm (2-in.) minimum immersion for power contacts and a 25-mm (1-in.) minimum immersion for control contacts.

This method prevents the arcing of a current interrupting contact.

(3) The interruption of current occurs within a factorysealed explosionproof chamber.



POWERPLEX PANELBOARD

INTERPRETATION OF ARTICLE 501: CLASS I LOCATIONS

This method prevents the propagation of an explosion into the general-purpose cavity of the enclosure.

(4) The device is a solid state, switching control without contacts, where the surface temperature does not exceed 80 percent of the autoignition temperature in degrees Celsius of the gas or vapor involved.

This method prevents arcing as it does not rely on contacts for its current interrupting function. This section permits the use of approved cartridge type fuses as supplementary protection within luminaires.

(2) **Isolating Switches.** Fused or unfused disconnect and isolating switches for transformers or capacitor banks that are not intended to interrupt current in the normal performance of the function for which they are installed shall be permitted to be installed in general-purpose enclosures.

(3) **Fuses.** For the protection of motors, appliances, and lamps, other than as provided in 501.115(B)(4), standard plug or cartridge fuses shall be permitted, provided they are placed within enclosures identified for the location; or fuses shall be permitted if they are within general-purpose enclosures, and if they are of a type in which the operating element is immersed in oil or other approved liquid, or the operating element is enclosed within a chamber hermetically sealed against the entrance of gases and vapors, or the fuse is a nonindicating, filled, current-limiting type.

NEC® Section 501.115(B)(2) permits the use of disconnect and isolating switches in general purpose enclosures in Class I, Division 2 locations if neither the switch or fuse operates as a normal current interrupting device. In such a case, the fuse is used for short-circuit protection only.

(4) **Fuses Internal to Luminaires.** Listed cartridge fuses shall be permitted as supplementary protection within luminaires.

Push button and selector switch control stations are used in conjunction with contactors or magnetic starters for remote control of motors.

Motor starter and circuit breaker enclosures, whether provided as combination units or as starters only or breakers only, are Class I, Division 1, suitable for use in wet locations — AEB Bolted Series, AE Threaded Cover Series: NEMA 4X.

501.120 Control Transformers and Resistors. Transformers, impedance coils, and resistors used as, or in conjunction with, control equipment for motors, generators, and appliances shall comply with 501.120(A) and (B).

(A) **Class I, Division 1.** In Class I, Division 1 locations, transformers, impedance coils, and resistors, together with any switching mechanism associated with them, shall be provided with enclosures identified for Class I, Division 1 locations in accordance with 501.105(A).

MOTOR STARTERS AND BREAKERS FOR CLASS I, DIVISION 1 AND 2



AEXMS CLASS I, DIVISION 1 & 2
MANUAL STARTER.



AE SERIES BOLTED COVER
CLASS I, DIVISION 1 & 2
CIRCUIT BREAKER.

MOTORSTARTERS FOR CLASS I, DIVISION 1 AND 2



AE SERIES
THREADED COVER



AEB SERIES
BOLTED COVER MOTOR STARTER

SWITCHRACK FOR CLASS I, DIVISION 2

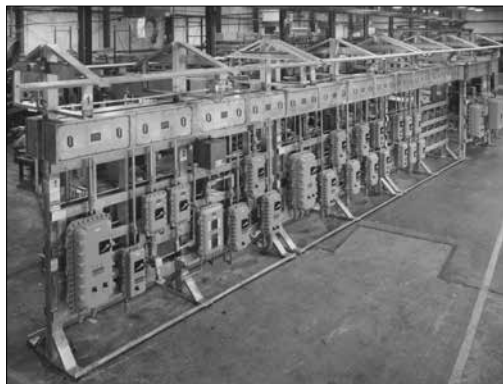

DISCONNECT SWITCHES FOR CLASS I, DIVISION 1.



GUSC TUMBLER — 30 AMP



EDS DISCONNECT —
30-200 AMP

INTERPRETATION OF ARTICLE 501: CLASS I LOCATIONS

(B) Class I, Division 2. In Class I, Division 2 locations, control transformers and resistors shall comply with 501.120(B)(1) through (B)(3).

(1) **Switching Mechanisms.** Switching mechanisms used in conjunction with transformers, impedance coils, and resistors shall comply with 501.115(B).

(2) Coils and Windings. Enclosures for windings of transformers, solenoids, or impedance coils shall be permitted to be of the general-purpose type.

(3) Resistors. Resistors shall be provided with enclosures; and the assembly shall be identified for Class I locations, unless resistance is nonvariable and maximum operating temperature, in degrees Celsius, will not exceed 80 percent of the autoignition temperature of the gas or vapor involved or the resistor has been tested and found incapable of igniting the gas or vapor.

501.125 Motors and Generators.

(A) **Class I, Division 1.** In Class I, Division 1 locations, motors, generators, and other rotating electrical machinery shall be one of the following:

(1) Identified for Class I, Division 1 locations

(2) Of the totally enclosed type supplied with positive pressure ventilation from a source of clean air with discharge to a safe area, so arranged to prevent energizing of the machine until ventilation has been established and the enclosure has been purged with at least 10 volumes of air, and also arranged to automatically de-energize the equipment when the air supply fails

(3) Of the totally enclosed inert gas-filled type supplied with a suitable reliable source of inert gas for pressurizing the enclosure, with devices provided to ensure a positive pressure in the enclosure and arranged to automatically de-energize the equipment when the gas supply fails

(4) Of a type designed to be submerged in a liquid that is flammable only when vaporized and mixed with air, or in a gas or vapor at a pressure greater than atmospheric and that is flammable only when mixed with air; and the machine is so arranged to prevent energizing it until it has been purged with the liquid or gas to exclude air, and also arranged to automatically de-energize the equipment when the supply of liquid or gas or vapor fails or the pressure is reduced to atmospheric

Totally enclosed motors of the types specified in 501.125(A)(2) or (A)(3) shall have no external surface with an operating temperature in degrees Celsius in excess of 80 percent of the autoignition temperature of the gas or vapor involved. Appropriate devices shall be provided to detect and automatically de-energize the motor or provide an adequate alarm if there is any increase in temperature of the motor beyond designed limits. Auxiliary equipment shall be of a type identified for the location in which it is installed.

(B) **Class I, Division 2.** In Class I, Division 2 locations, motors, generators, and other rotating electrical machinery in which are employed sliding contacts, centrifugal or other types of switching mechanism (including motor overcurrent, overloading, and overtemperature devices), or integral resistance devices, either while starting or while running, shall be identified for Class I, Division 1 locations, unless such sliding contacts, switching mechanisms, and resistance devices are provided with enclosures identified for Class I, Division 2 locations in accordance with 501.105(B). The exposed surface of space heaters used to prevent condensation of moisture during shutdown periods shall not exceed 80 percent of the autoignition

PANELBOARDS FOR CLASS I, DIVISION 1 & 2.



ALPN — NON-FACTORY SEALED
PANELBOARD



POWERPLEX PANELBOARD
(DIVISION 2)

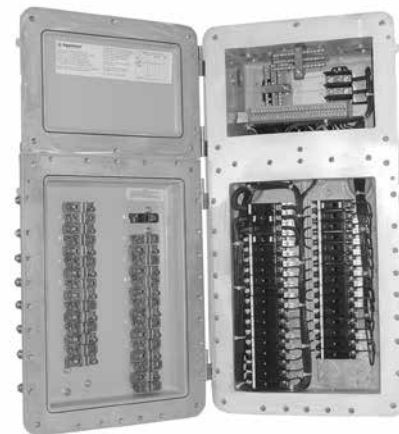

EWP — FACTORY SEALED

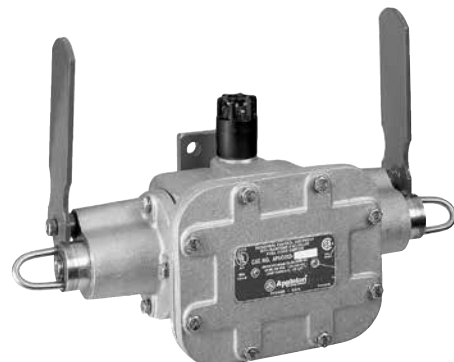

AFU — DOUBLE END CONVEYOR SWITCH

INTERPRETATION OF ARTICLE 501: CLASS I LOCATIONS

temperature in degrees Celsius of the gas or vapor involved when operated at rated voltage, and the maximum space heater surface temperature [based on a 40°C or higher marked ambient] shall be permanently marked on a visible nameplate mounted on the motor. Otherwise, space heaters shall be identified for Class I, Division 2 locations. In Class I, Division 2 locations, the installation of open or nonexplosionproof enclosed motors, such as squirrel-cage induction motors without brushes, switching mechanisms, or similar arc producing devices that are not identified for use in a Class I, Division 2 location, shall be permitted.

NEC® Section 501.125(B) requires that all motors, generators, and other rotating electric machinery with sliding contacts, centrifugal or other types of switching mechanism (including motor overcurrent, overloading, and overtemperature devices), or integral resistance devices, either while starting or while running be identified for Class I, Division 1 locations except where the sliding contacts, switching mechanisms, and resistance devices are provided with enclosures identified for Class I, Division 2 locations in accordance with Section 501.105(B). However the installation of open or nonexplosionproof enclosed motors, such as squirrel-cage induction motors without brushes, switching mechanisms, or similar arc-producing devices that are not identified for use in, are acceptable in a Class I, Division 2 location.

Informational Note No. 1: It is important to consider the temperature of internal and external surfaces that may be exposed to the flammable atmosphere.

NEC® Section 501.125(B) Informational Note 1 adds an extra cautionary note that urges consideration of internal and external surface temperature of the electrical equipment that may be exposed to the flammable atmosphere.

Informational Note No. 2: It is important to consider the risk of ignition due to currents arcing across discontinuities and overheating of parts in multisection enclosures of large motors and generators. Such motors and generators may need equipotential bonding jumpers across joints in the enclosure and from enclosure to ground. Where the presence of ignitable gases or vapors is suspected, clean-air purging may be needed immediately prior to and during start-up periods.

Informational Note 2 urges caution in the case of multisection enclosures of large motors and generators, which may (1) arc across discontinuities and (2) overheat in some parts. Recommended precautionary action includes (1) the use of equipotential bonding jumpers across joints in the enclosures and from enclosure to ground, and (2) clean air purging immediately before and during startup periods where ignitable gases or vapors are suspected. The reason for the Informational Note 2 is that overheating of parts is not only caused by transient currents, but also may occur during motor starting, fault contribution or load changes.

Informational Note No. 3: For further information on the application of electric motors in Class I, Division 2 hazardous (classified) locations, see IEEE 1349-2011, *IEEE Guide for the Application of Electric Motors in Class I, Division 2 and Class I, Zone 2 Hazardous (Classified) Locations*.

IEEE 1349 now addresses Class I, Zone 2 locations as well as Class I, Division 2 Hazardous (Classified) Locations.

Due to the concerns emphasized in Informational Note 1 and 2, often motors suitable for Class I, Division 1 are selected for Class I, Division 2 applications.

Informational Note No. 4: Reciprocating engine-driven generators, compressors, and other equipment installed in Class I, Division 2 locations may present a risk of ignition of flammable materials associated with fuel, starting, compression, and so forth, due to

inadvertent release or equipment malfunction by the engine ignition system and controls. For further information on the requirements for ignition systems for reciprocating engines installed in Class I, Division 2 hazardous (classified) locations, see ANSI/ISA-12.20.01-2009, *General Requirements for Electrical Ignition Systems for Internal Combustion Engines in Class I, Division 2 or Zone 2, Hazardous (Classified) Locations*.

This Information Note identifies the product standard that addresses risk of ignition with engine driven equipment due to fuel, starting, compression etc.

501.130 Luminaires. Luminaires shall comply with 501.130(A) or (B).

(A) Class I, Division 1. In Class I, Division 1 locations, luminaires shall comply with 501.130(A)(1) through (A)(4).

NEC® Section 501.130(A) applies where lamps are of a size or type that may, under normal operating conditions, reach surface temperatures exceeding 80 percent of the ignition temperature in degrees Celsius of the gas or vapor involved, except where a type that has been tested in order to determine the marked operating temperature or temperature class (T Code) is installed.

(1) Luminaires. Each luminaire shall be identified as a complete assembly for the Class I, Division 1 location and shall be clearly marked to indicate the maximum wattage of lamps for which it is identified. Luminaires intended for portable use shall be specifically listed as a complete assembly for that use.

In Class I, Division 1, luminaires must be identified for the location. They must be protected against damage by locating luminaire so accidental damage is unlikely or by suitable guards. Appleton Class I, Division 1 luminaires are all factory sealed by construction, eliminating need for external seals.

(2) Physical Damage. Each luminaire shall be protected against physical damage by a suitable guard or by location.



In Class I, Division 1 locations all luminaires (lighting fixtures) are required to be identified as a complete assembly and protected against physical damage by a suitable guard or by location. They must be

INTERPRETATION OF ARTICLE 501: CLASS I LOCATIONS

TYPICAL FIXTURE HANGER INSTALLATIONS — CLASS I AND II, DIVISION 1*

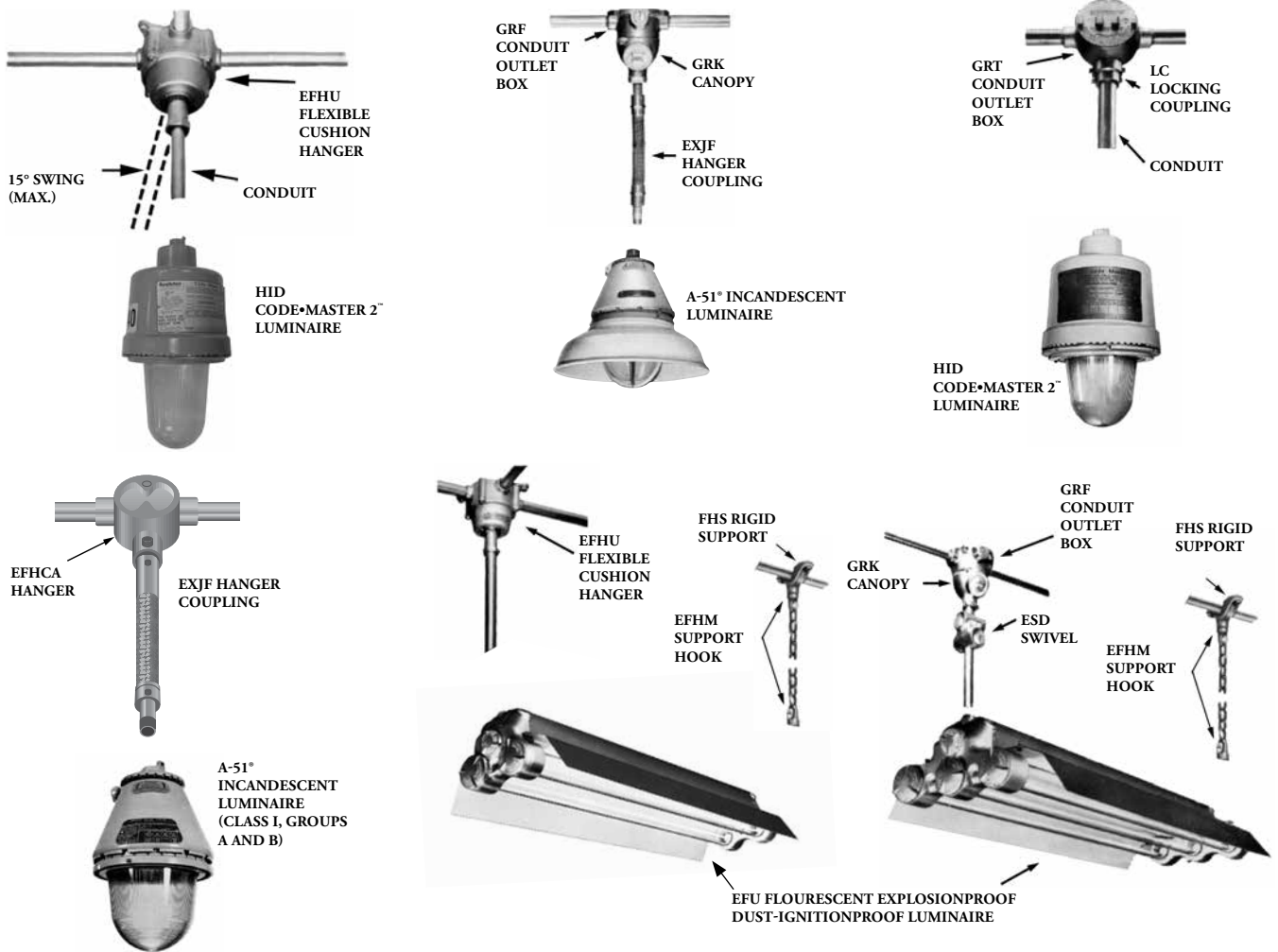

CLASS I, DIVISION 2*

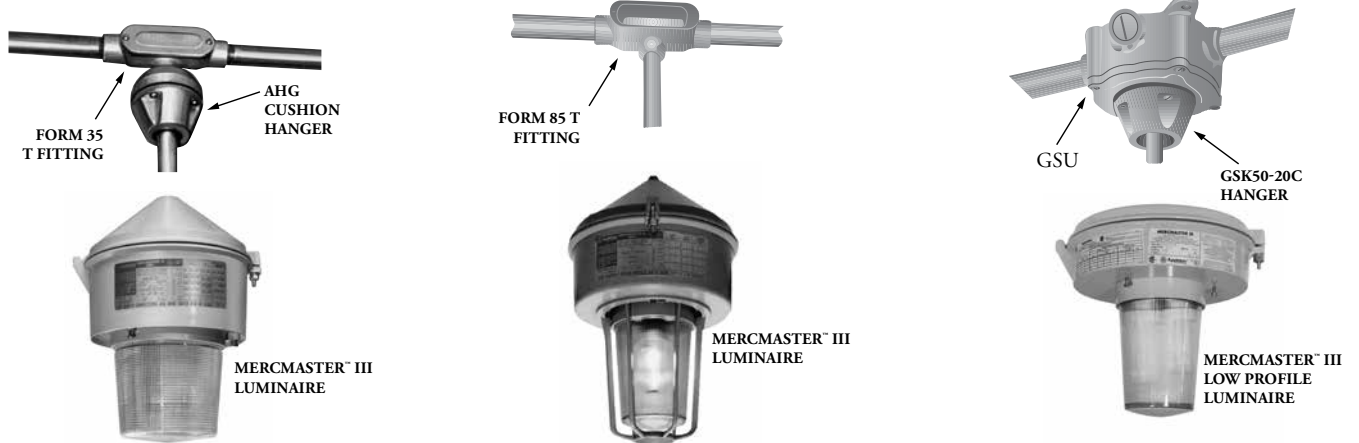

*FIXTURES USING STEMS LONGER THAN 12" MUST HAVE FLEXIBLE FITTING.

INTERPRETATION OF ARTICLE 501: CLASS I LOCATIONS

clearly marked to indicate the maximum wattage of lamps for which it is identified. Where they are intended for portable use they must be specifically listed as a complete assembly for that use.

(3) **Pendant Luminaires.** Pendant luminaires shall be suspended by and supplied through threaded rigid metal conduit stems or threaded steel intermediate conduit stems, and threaded joints shall be provided with set-screws or other effective means to prevent loosening. For stems longer than 300 mm (12 in.), permanent and effective bracing against lateral displacement shall be provided at a level not more than 300 mm (12 in.) above the lower end of the stem, or flexibility in the form of a fitting or flexible connector identified for the Class I, Division 1 location shall be provided not more than 300 mm (12 in.) from the point of attachment to the supporting box or fitting.

Pendant Luminaires must be suspended by and supplied through threaded Rigid Metal Conduit or steel Intermediate Metal Conduit. Stems up to 12 in. (300mm), and threaded joints are required to be provided with set-screws or other effective means to prevent loosening. Longer stems require permanent and effective bracing against lateral displacement or a Class I, Division 1 identified flexible fitting or connector.

(4) **Supports.** Boxes, box assemblies, or fittings used for the support of luminaires shall be identified for Class I locations.

(B) **Class I, Division 2.** In Class I, Division 2 locations, luminaires shall comply with 501.130(B)(1) through (B)(6).

(1) **Luminaires.** Where lamps are of a size or type that may, under normal operating conditions, reach surface temperatures exceeding 80 percent of the autoignition temperature in degrees Celsius of the gas or vapor involved, luminaires shall comply with 501.130(A)(1) or shall be of a type that has been tested in order to determine the marked operating temperature or temperature class (T code).

(2) **Physical Damage.** Luminaires shall be protected from physical damage by suitable guards or by location. Where there is danger that falling sparks or hot metal from lamps or luminaires might ignite localized concentrations of flammable vapors or gases, suitable enclosures or other effective protective means shall be provided.

In Class I, Division 2 locations, fixed luminaires shall be protected from physical damage by suitable guards or by location and where there is danger that falling sparks or hot metal from lamps or luminaires might ignite flammable vapors or gases they must be in suitable enclosures or other effective protective means must be provided.

(3) **Pendant Luminaires.** Pendant luminaires shall be suspended by threaded rigid metal conduit stems, threaded steel intermediate metal conduit stems, or other approved means. For rigid stems longer than 300 mm (12 in.), permanent and effective bracing against lateral displacement shall be provided at a level not more than 300 mm (12 in.) above the lower end of the stem, or flexibility in the form of an identified fitting or flexible connector shall be provided not more than 300 mm (12 in.) from the point of attachment to the supporting box or fitting.

(4) **Portable Lighting Equipment.** Portable lighting equipment shall comply with 501.130(A)(1).

Exception: Where portable lighting equipment is mounted on movable stands and is connected by flexible cords, as covered in 501.140, it shall be permitted to comply with 501.130(B)(1), where mounted in any position, provided that it also complies with 501.130(B)(2).

FIXTURE HANGERS — CLASS I, DIVISION 1



LED LUMINAIRES — CLASS I, DIVISION 2



HID LUMINAIRES — CLASS I, DIVISION 2



FLUORESCENT LUMINAIRES — CLASS I, DIVISION 2

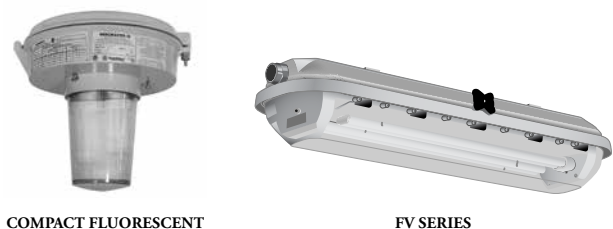

INTERPRETATION OF ARTICLE 501: CLASS I LOCATIONS

INCANDESCENT LUMINAIRES — CLASS I, DIVISION 2



STYLMASTER™

MERCMASTER™ III QL

V-51*

ALL CLASS I, DIVISION 2 LED, HID, FLUORESCENT AND INCANDESCENT LUMINAIRES SHOWN ON THESE TWO PAGES ARE ENCLOSED AND GASKETED AND THEREFORE SUITABLE FOR USE IN WET LOCATIONS. THEIR CONSTRUCTION MAKES THEM SUITABLE FOR CLASS I, DIVISION 2 LOCATIONS. SUCH LUMINAIRES ARE MORE ECONOMICAL TO INSTALL IN AREAS WHERE CLASS I, DIVISION 1 LUMINAIRES ARE NOT REQUIRED.

NEC® Section 501.130(B)(4) Exception states that portable luminaires used in Class I, Division 2 locations do not have to be approved for Class I, Division 1 if they are mounted on a movable stand and connected by an approved flexible cord. The luminaire only needs to be approved for Class I, Division 2, providing it conforms to Section 501.130(B)(2), which specifies:

- (1) that luminaire be protected by suitable guard or location;
- (2) that luminaire has suitable enclosure to prevent sparks or hot metal from lamp causing ignition of the surrounding atmosphere; and
- (3) that luminaire does not exceed temperature limitations.

INCANDESCENT LUMINAIRE — CLASS I, DIVISION 1



G-EFWB

FLUORESCENT LUMINAIRE — CLASS I, DIVISION 1



PAPL

CAUTION: Restrictions on portable electric lamps are more severe in applications covered in Article 516. During spray operation in Class I [as covered in Section 516.4(D)] and during cleaning and repair operations in Class I (as covered in Section 501.130), portable lamps must be approved for Class I, Division 1 and/or Class II, Division 1. However, in Class I cleaning and repair operations, Section

501.130(B)(1) and Exception applies, meaning that a portable lamp approved for Class I, Division 2 may be used if it is mounted on a movable stand and is connected by an approved flexible cord.

(5) Switches. Switches that are a part of an assembled fixture or of an individual lampholder shall comply with 501.115(B)(1).

(6) Starting Equipment. Starting and control equipment for electric-discharge lamps shall comply with 501.120(B).

Exception: A thermal protector potted into a thermally protected fluorescent lamp ballast if the luminaire is identified for the location.

CLASS I, DIVISION 1 AND 2, GROUP D.

Appleton Reelites® (power cable reels) are used to provide power or electrical control over long distances to movable utilization equipment, such as machinery, cranes and machine tools where constant cable tension is required to automatically take up cable slack as equipment moves. Reelites also provide storage and safety for these retractable power sources.

EXPLOSIONPROOF REELITES® FOR USE WITH UTILIZATION EQUIPMENT.

APPLETON REELITES® CLASS I, DIVISION 1 AND 2



AERL SERIES

501.135 Utilization Equipment.

(A) Class I, Division 1. In Class I, Division 1 locations, all utilization equipment shall be identified for Class I, Division 1 locations.

(B) Class I, Division 2. In Class I, Division 2 locations, all utilization equipment shall comply with 501.135(B)(1) through (B)(3).

(1) Heaters. Electrically heated utilization equipment shall conform with either item (1) or item (2):

(1) The heater shall not exceed 80 percent of the autoignition temperature in degrees Celsius of the gas or vapor involved on any surface that is exposed to the gas or vapor when continuously energized at the maximum rated ambient temperature. If a temperature controller is not provided, these conditions shall apply when the heater is operated at 120 percent of rated voltage.

NEC® Section 501.135(B)(1) elaborates on the use of electrically heated utilization equipment in Class I, Division 2 locations. This equipment either (1) could not exceed 80% of the ignition temperature of the atmosphere encountered when operated at 120% of rated voltage or (2) it must be approved for Class I, Division 1.

INTERPRETATION OF ARTICLE 501: CLASS I LOCATIONS

Section 501.135(B)(1)(1), Exception permits “electrical resistance heat tracing approved for Class I, Division 2 locations” (not Class I, Division 1).

Exception No. 1: For motor-mounted anticondensation space heaters, see 501.125.

NEC® Section 501.135(B)(1) Exception 1 excludes motor-mounted anti-condensation space heaters from the requirement that they not exceed 80% of the ignition temperature in degrees Celsius when operated at 120% of rated voltage. In such a case, Section 501.125(B) applies, which states that “When operated at rated voltage, the exposed surface of space heaters used to prevent condensation of moisture during shut-down periods shall not exceed 80% of the ignition temperature in degrees Celsius of the gas or vapor involved.” In other words, Section 501.125(B) specified “at rated voltage.”

Exception No. 2: Where a current-limiting device is applied to the circuit serving the heater to limit the current in the heater to a value less than that required to raise the heater surface temperature to 80 percent of the autoignition temperature.

(2) The heater shall be identified for Class I, Division 1 locations.

Exception to (2): Electrical resistance heat tracing identified for Class I, Division 2 locations.

NEC® Section 501.135(B)(1)(1), Exception 2 permits, in a Class I, Division 2 location, the use of electrically heated utilization equipment if some current-limiting means is provided to prevent the equipment temperature from exceeding 80% of the ignition temperature of the gas or vapor involved or be identified for Class I, Division 1 location.

(2) **Motors.** Motors of motor-driven utilization equipment shall comply with 501.125(B).

(3) **Switches, Circuit Breakers, and Fuses.** Switches, circuit breakers, and fuses shall comply with 501.115(B).



EDS CONTROL STATION



CONTENDER EDS
MANUAL MOTOR STARTERS

501.140 Flexible Cords, Class I, Divisions 1 and 2.

(A) **Permitted Uses.** Flexible cord shall be permitted:

(1) For connection between portable lighting equipment or other portable utilization equipment and the fixed portion of their supply circuit. The flexible cord shall be attached to the utilization equipment with a cord connector listed for the protection technique of the equipment wiring compartment. An attachment plug in accordance

with 501.140(B)(4) shall be employed.

Flexible cord used on portable lighting equipment or other portable utilization equipment must be attached to the utilization equipment with a cord connector that meets the rating of the portable equipment. This is regardless of what classified area the utilization equipment is being used in. An example would be an explosionproof portable luminaire. The cord that connects the luminaire would be required to be explosionproof even if the luminaire was being utilized in a Class I, Division 2 location.

(2) For that portion of the circuit where the fixed wiring methods of 501.10(A) cannot provide the necessary degree of movement for fixed and mobile electrical utilization equipment, and the flexible cord is protected by location or by a suitable guard from damage and only in an industrial establishment where conditions of maintenance and engineering supervision ensure that only qualified persons install and service the installation.

(3) For electric submersible pumps with means for removal without entering the wet-pit. The extension of the flexible cord within a suitable raceway between the wet-pit and the power source shall be permitted.

(4) For electric mixers intended for travel into and out of open-type mixing tanks or vats.

(5) For temporary portable assemblies consisting of receptacles, switches, and other devices that are not considered portable utilization equipment but are individually listed for the location.

This Section addresses equipment such as portable power carts where these types of equipment do not meet the definition as portable utilization equipment but provide portable power to utilization equipment.

(B) **Installation.** Where flexible cords are used, the cords shall comply with all of the following:

(1) Be of a type listed for extra-hard usage

(2) Contain, in addition to the conductors of the circuit, an equipment grounding conductor complying with 400.23

(3) Be supported by clamps or by other suitable means in such a manner that there is no tension on the terminal connections

(4) In Division 1 locations or in Division 2 locations where the boxes, fittings, or enclosures are required to be explosionproof, the cord shall be terminated with a cord connector or attachment plug listed for the location or a listed cord connector installed with a seal listed for the location. In Division 2 locations where explosionproof equipment is not required, the cord shall be terminated with a listed cord connector or listed attachment plug.

When the cord connector is installed into a seal that is “listed for the location” the cord connector need only be listed for use with the cord. It is not also required to be “listed for the location”.

This Section addresses the proper methods for sealing cord entering enclosures that are required to be explosionproof and those instances where the cord is installed in a Class I, Division 2 location and is feeding equipment that is not required to be explosionproof. For non-explosionproof installation the cord connector must simply be listed for the cord, not listed for the location.

(5) Be of continuous length. Where 501.140(A)(5) is applied, cords

INTERPRETATION OF ARTICLE 501: CLASS I LOCATIONS

shall be of continuous length from the power source to the temporary portable assembly and from the temporary portable assembly to the utilization equipment.

Informational Note: See 501.20 for flexible cords exposed to liquids having a deleterious effect on the conductor insulation.

This Section addresses the installation requirements for the new provision added in section 501.140(A)(5) relating to temporary portable assemblies. In these installations both the cord from the fixed supply power source to the temporary portable assembly and the cord from the temporary portable assembly to the utilization equipment must be a continuous length.

NEC® Section 501.140 limits flexible cords to connections between portable utilization equipment, such as a lamp, and the fixed portion of a supply circuit now with the permitted use of an intermittent temporary portable assembly such as a power cart that is listed for the location. In addition, that portion of the circuit where the fixed wiring methods of Section 501.10(A) cannot provide the necessary degree of movement for fixed and mobile electrical utilization equipment, in an industrial establishment where conditions of maintenance and engineering supervision ensure that only qualified persons will install and service the installation, and the flexible cord is protected by location or by a suitable guard from damage the flexible cord must be continuous. A cord connector used as an extension cord, therefore, is not permitted in Class I, Division 1 locations. Where flexible cords are used they shall be a type approved for “extra hard usage” (see Table 400.4) and must include a grounding conductor identified with markings as specified in Section 400.23. They must be connected to terminals or supply conductors in an approved manner. They must be supported so that there will be no tension on the terminals or connections, and they must be provided with suitable seals where required.

NEC® Section 501.140 classifies an electric submersible pump with means for removal without entering the wet-pit as portable utilization equipment. Thus defined, flexible cord is permitted “between this product and the fixed portion of the supply circuit.”

NEC® Section 501.140 classifies electric mixers as portable utilization “if intended for travel into and out of open-type mixing tanks or vats.” Flexible cord may be used between this product and the fixed portion of the supply circuit. This permission is granted because there is no other practical method available to power this type of equipment besides the use of flexible cord.

501.145 Receptacles and Attachment Plugs, Class I, Divisions 1 and 2.

(A) Receptacles. Receptacles shall be part of the premises wiring, except as permitted by 501.140(A).

(B) Attachment Plugs. Attachment plugs shall be of the type providing for connection to the equipment grounding conductor of a flexible cord and shall be identified for the location.

Exception: Receptacles and attachment plugs as provided in 501.105(B)(6).

Section revised to clarify that the receptacle is part of the premises wiring and the plug is part of the utilization equipment.

Arcing at exposed contacts must be prevented in Class I, Division 1 or 2 locations. Accordingly, receptacles are designed so that plug contacts are safely within an explosionproof enclosure when they are electrically engaged, confining arcing if any to the receptacle interior. This is accomplished in two ways:

RECEPTACLES AND PLUGS—CLASS I, DIVISION 1 AND 2.



Receptacles with Switches. In the FSQX, FSQC, EBR, EBRH, U-Line® and N1 and N2 receptacles, the plug cannot be inserted unless the switch is in the OFF position and cannot be withdrawn with the receptacle in the ON position. This means that arcing does not occur outside the enclosure because mated parts are dead during plug insertion and withdrawal.

Receptacles without Switches. CES/CESD receptacles rely on mechanical means (Delayed Action) rather than on switches to confine arcing to the receptacle interior during plug insertion and withdrawal. To operate, insert plug to first stop, move Slide-Lok® slide to right and push plug fully forward. The construction design used in these receptacles prevents removal of the plug until any flame, spark or hot metal from an arc has cooled sufficiently to prevent ignition of the surrounding atmosphere.

CES/CESD



501.150 Signaling, Alarm, Remote-Control, and Communications Systems.

(A) Class I, Division 1. In Class I, Division 1 locations, all apparatus and equipment of signaling, alarm, remote-control, and communications systems, regardless of voltage, shall be identified for Class I, Division 1 locations, and all wiring shall comply with 501.10(A), 501.15(A), and 501.15(C).

(B) Class I, Division 2. In Class I, Division 2 locations, signaling, alarm, remote-control, and communications systems shall comply with 501.150(B)(1) through (B)(4).

(1) Contacts. Switches, circuit breakers, and make-and-break contacts of pushbuttons, relays, alarm bells, and horns shall have enclosures

INTERPRETATION OF ARTICLE 501: CLASS I LOCATIONS

identified for Class I, Division 1 locations in accordance with 501.105(A).

Exception: General-purpose enclosures shall be permitted if current-interrupting contacts are one of the following:

- (1) Immersed in oil*
- (2) Enclosed within a chamber hermetically sealed against the entrance of gases or vapors*
- (3) In nonincendive circuits*
- (4) Part of a listed nonincendive component*

(2) Resistors and Similar Equipment. Resistors, resistance devices, thermionic tubes, rectifiers, and similar equipment shall comply with 501.105(B)(2).

(3) Protectors. Enclosures shall be provided for lightning protective devices and for fuses. Such enclosures shall be permitted to be of the general-purpose type.

(4) Wiring and Sealing. All wiring shall comply with 501.10(B), 501.15(B), and 501.15(C).

INTERPRETATION OF ARTICLE 502: CLASS II LOCATIONS

CHANGES TO ARTICLE 502

The following Article 502 sections have been revised during the 2014 *NEC*® Code cycle. These changes are those that are substantive and should be noted. This list does not include those changes that are editorial in nature.

Underlined text indicates a section that has been revised from the previous *NEC*® edition. It is not intended to indicate legislation text detailing the word-for-word revisions to the section. Where minor revisions have been made to a section, these will include underlined text for select words to indicate the minor revision.

- **Section 502.10(A)(1)(4)**
Wiring Methods. Class II, Division 1. General. Optical Fiber Cable
- **Section 502.10(A)(2)(6)**
Wiring Methods. Class II, Division 1. Flexible Connections. Elevator Cables
- **Section 502.10(A)(3)**
Wiring Methods. Class II, Division 1. Boxes and Fittings
- **Section 502.10(B)(1)(8)**
Wiring Methods. Class II, Division 2. General. Optical Fiber Cable
- **Section 502.130(A)(1)**
Luminaires. Class II, Division 1. Marking
- **Section 502.140(A)**
Flexible Cords – Class II, Divisions 1 and 2. Permitted Uses
- **Section 502.140(B)**
Flexible Cords – Class II, Divisions 1 and 2. Installation
- **Section 502.145**
Receptacles and Attachment Plugs

The general rules in *NEC*® chapters one through four apply to the electronic wiring and equipment in locations classified as Class II unless modified by Article 502.

The rules in Article 500 also apply to Article 502.

For additional information on Class II dusts, see Appendix A-5 through A-6 of this booklet.

I. General

502.1 Scope. Article 502 covers the requirements for electrical and electronic equipment and wiring for all voltages in Class II, Division 1 and 2 locations where fire or explosion hazards may exist due to combustible dust.

502.5 Explosionproof Equipment. Explosionproof equipment and wiring shall not be required and shall not be acceptable in Class II locations unless also identified for such locations.

IMPORTANT: In Class II, Division 1 locations where dust from magnesium, aluminum, aluminum bronze powders, or other metals of similarly hazardous characteristics may be present, no transformers or capacitors shall be installed. The general rules in *NEC*® chapters one through four apply to the electronic wiring and equipment in locations classified as Class II in Section 500.5(C) unless modified by Article 502.

502.6 Zone Equipment. Equipment listed and marked in accordance with 506.9(C)(2) for Zone 20 locations shall be permitted in Class II, Division 1 locations for the same dust atmosphere; and with a suitable temperature class.

Equipment listed and marked in accordance with 506.9(C)(2) for Zone 20, 21, or 22 locations shall be permitted in Class II, Division 2 locations for the same dust atmosphere and with a suitable temperature class.

II. Wiring

502.10 Wiring Methods. Wiring methods shall comply with 502.10(A) or (B).

(A) Class II, Division 1.

(1) General. In Class II, Division 1 locations, the wiring methods in (1) through (4) shall be permitted:

(1) Threaded rigid metal conduit, or threaded steel intermediate metal conduit.

(2) Type MI cable with termination fittings listed for the location. Type MI cable shall be installed and supported in a manner to avoid tensile stress at the termination fittings.

(3) In industrial establishments with limited public access, where the conditions of maintenance and supervision ensure that only qualified persons service the installation, Type MC-HL cable, listed for use in Class II, Division 1 locations, with a gas/vaportight continuous corrugated metallic sheath, an overall jacket of suitable polymeric material, a separate equipment grounding conductor(s) in accordance with 250.122, and provided with termination fittings listed for the location, shall be permitted.

(4) Optical fiber cables Types OFNP, OFCP, OFNR, OFCR, OFNG, OFCG, OFN, and OFC shall be permitted to be installed in raceways in accordance with 502.10(A). Optical fiber cables shall be sealed in accordance with 502.15.

This Section now permits these types of cables to be installed in raceway in a Class II, Division 1 location and correlates with the permitted uses found in Section 770.3(A). They are required to be sealed in accordance with Section 502.15.

(2) Flexible Connections.

Where necessary to employ flexible connections, one or more of the following shall also be permitted:

(1) Dusttight flexible connectors.

(2) Liquidtight flexible metal conduit with listed fittings.

(3) Liquidtight flexible nonmetallic conduit with listed fittings.

In Class II, Division 1 locations, liquidtight flexible nonmetallic conduit with listed fittings, may be used where flexible connections

INTERPRETATION OF ARTICLE 502: CLASS II LOCATIONS

are necessary. The same permission also applies to Class III locations [Section 503.10(A)(2)].

Appleton offers the EXGJH or EXLK Flexible Coupling and the ST Liquid Tight Connector (for use with liquidtight flexible metal conduit). Flexible cords used with the Appleton CG and factory sealed ECC Cord Connectors must be an S or SO type and comply with all the provisions of Section 502.140.

(4) Interlocked armor Type MC cable having an overall jacket of suitable polymeric material and provided with termination fittings listed for Class II, Division 1 locations.

(5) Flexible cord listed for extra-hard usage and terminated with listed dusttight cord connectors. Where flexible cords are used, they shall comply with 502.140.

(6) For elevator use, an identified elevator cable of Type EO, ETP, or ETT, shown under the “use” column in Table 400.4 for “hazardous (classified) locations” and terminated with listed dusttight fittings.

Informational Note: See 502.30(B) for grounding requirements where flexible conduit is used.

Flexible cord is required to be terminated with listed cord connectors. A cord connector is type of fitting. This only means the cord connectors are to be listed for use with the specific cord. It does mean that the fitting must be listed “for the location”.

Where the flexible connections are subject to oil or other corrosive conditions, the insulation of the conductors shall be a type listed for the condition or shall be protected with a suitable sheath (see Section 502.30(B) for grounding requirements).

Elevator cables are permitted to be used where flexibility is necessary. The cable shall be identified as Types EO, ETP, or ETT. The fittings used to terminate these cables shall be listed for use with these cable identifications and also maintain a dusttight joint.

(3) **Boxes and Fittings.** Boxes and fittings shall be provided with threaded bosses for connection to conduit or cable terminations and shall be dusttight. Boxes and fittings in which taps, joints, or terminal connections are made, or that are used in Group E locations, shall be identified for Class II locations.

Informational Note: For entry into enclosures required to be dust-ignitionproof, see the information on construction, testing, and marking of cables, dust-ignitionproof cable fittings, and dust-ignitionproof cord connectors in ANSI/UL 2225-2011, *Cables and Cable-Fittings for Use in Hazardous (Classified) Locations*.

Although the requirement that all boxes and fittings are required to be dusttight appears to conflict with the permissible protection techniques of Section 500.7 for Class II, Division 1 locations, it is intended to require all boxes and fittings be sufficiently designed so that dusts will not enter under specified test conditions.

These boxes and fittings are not required to be “listed” as dusttight. For guidance on dusttight ratings see NEMA 250, Enclosures for Electrical Equipment (1000 Volts Maximum) permits a rating of “dusttight” for products that are rated NEMA Types 3, 3X, 3S, 3SX, 5, 12, 12K, or 13.

Fittings and boxes permitted in Class II, Division 1 locations must be dusttight with threaded bosses for connection to conduit or cable terminations. Fittings and boxes in which taps, joints, or terminal connections are made, or that are used in Group E locations, are required to be identified for Class II locations (see definition of identified), typically dust-ignitionproof.

(B) Class II, Division 2.

(1) **General.** In Class II, Division 2 locations, the following wiring methods shall be permitted:

- (1) All wiring methods permitted in 502.10(A).
- (2) Rigid metal conduit, intermediate metal conduit, electrical metallic tubing, dusttight wireways.
- (3) Type MC or MI cable with listed termination fittings.
- (4) Type PLTC and Type PLTC-ER cable in accordance with the provisions of Article 725, including installation in cable tray systems. The cable shall be terminated with listed fittings.
- (5) Type ITC and Type ITC-ER cable as permitted in 727.4 and terminated with listed fittings.

PLTC-ER and ITC-ER cables are permitted in Class II, Division 2 locations. The cable must be terminated with fittings that are listed for the type of cable. These fittings are not required to be listed “for the location”, in this case Class II, Division 2.

(6) Type MC, MI, or TC cable installed in ladder, ventilated trough, or ventilated channel cable trays in a single layer, with a space not less than the larger cable diameter between the two adjacent cables, shall be the wiring method employed.

Exception to (6): Type MC cable listed for use in Class II, Division 1

WIRING METHODS—CLASS II, DIVISION 1 AND 2 GROUPS E, F AND G.

BOXES



GRU



GRSS



GRX



GRJS



CPU

FITTINGS



UNY



EXGJH/EXLK



TMC2



CG



ST

INTERPRETATION OF ARTICLE 502: CLASS II LOCATIONS

locations shall be permitted to be installed without the spacings required by (6).

(7) In industrial establishments with restricted public access where the conditions of maintenance and supervision ensure that only qualified persons service the installation and where metallic conduit does not provide sufficient corrosion resistance, reinforced thermosetting resin conduit (RTRC) factory elbows, and associated fittings, all marked with suffix -XW, and Schedule 80 PVC conduit, factory elbows and associated fittings shall be permitted.

Type MC cable listed for use in Class II, Division 1 locations shall be permitted to be installed in Class II, Division 2 locations without the spacings that are required for the Class II, Division 1 locations.

In Class II, Division 2 locations all of the wiring methods acceptable for Class II, Division 1 may be used. It is important to note that threaded conduit is not required. (RMC) Rigid Metal Conduit and (IMC) Intermediate Metal Conduit may be used with threadless fittings. Also acceptable in Division 2 applications are (EMT) Electrical Metallic Tubing, Dusttight Wireways, Type MC or MI cable with listed termination fittings, Type PLTC in cable trays, Type ITC in cable trays and Type MC, MI, or TC cable installed in ladder, ventilated trough, or ventilated channel cable trays in a single layer, with a space not less than the larger cable diameter between the two adjacent cables.

(8) Optical fiber cable Types OFNP, OFCP, OFNR, OFCR, OFNG, OFCG, OFN, and OFC shall be permitted to be installed in cable trays or any other raceway in accordance with 502.10(B). Optical fiber cables shall be sealed in accordance with 502.15.

This Section now permits these types of cables to be installed in cable trays or any other raceway in a Class II, Division 2 location and correlates with the permitted uses found in Section 770.3(A). They are required to be sealed in accordance with Section 502.15.

(2) Flexible Connections. Where provision must be made for flexibility, 502.10(A)(2) shall apply.

Where flexibility is necessary only those wiring methods permitted for Class II, Division 1 in Section 502.10(A)(2) can be used. The prevalent requirement for these types of raceways and cable systems is to prevent the ingress of dust into the electrical systems.

(3) Nonincendive Field Wiring. Nonincendive field wiring shall be permitted using any of the wiring methods permitted for unclassified locations. Nonincendive field wiring systems shall be installed in accordance with the control drawing(s). Simple apparatus, not shown on the control drawing, shall be permitted in a nonincendive field wiring circuit, provided the simple apparatus does not interconnect the nonincendive field wiring circuit to any other circuit.

Informational Note: Simple apparatus is defined in 504.2.

Separate nonincendive field wiring circuits shall be installed in accordance with one of the following:

- (1) In separate cables
- (2) In multiconductor cables where the conductors of each circuit are within a grounded metal shield
- (3) In multiconductor cables or in raceways where the conductors of each circuit have insulation with a minimum thickness of 0.25 mm (0.01 in.)

Nonincendive field wiring is permitted using any of the wiring methods permitted for unclassified locations. However the nonincendive system must be installed in accordance with the control drawing(s). "Simple apparatus", not shown on the control drawing, is permitted in a nonincendive field wiring circuit, provided the simple apparatus does not interconnect the nonincendive field wiring circuit to any other circuit. See Section 504.2 for the definition of "Simple Apparatus". Separate nonincendive field wiring circuits shall be in separate cables, in multiconductor cables where the conductors of each circuit are within a grounded metal shield, or in multiconductor cables where the conductors of each circuit have insulation with a minimum thickness of 0.25 mm (0.01 in.).



CLASS II, DIVISION 1 AND 2, GROUP G GRAIN ELEVATOR.

(4) Boxes and Fittings. All boxes and fittings shall be dusttight.

502.15 Sealing, Class II, Divisions 1 and 2. Where a raceway provides communication between an enclosure that is required to be dust-ignitionproof and one that is not, suitable means shall be provided to prevent the entrance of dust into the dust-ignitionproof enclosure through the raceway. One of the following means shall be permitted:

- (1) A permanent and effective seal
- (2) A horizontal raceway not less than 3.05 m (10 ft) long
- (3) A vertical raceway not less than 1.5 m (5 ft) long and extending downward from the dust-ignitionproof enclosure
- (4) A raceway installed in a manner equivalent to (2) or (3) that extends only horizontally and downward from the dust-ignition proof enclosures

Where a raceway provides communication between an enclosure that is required to be dust-ignitionproof and an enclosure in an unclassified location, seals shall not be required.

Sealing fittings shall be accessible.

Seals shall not be required to be explosionproof.

Informational Note: Electrical sealing putty is a method of sealing.

Dust-ignitionproof enclosures are designed to keep dust out and thus not permit an internal dust explosion to occur. They are not designed

INTERPRETATION OF ARTICLE 502: CLASS II LOCATIONS

to withstand internal dust explosions. The intent of the Article is to prevent dust from entering the dust-ignitionproof enclosure through the raceway. Fig. 1 (on following page) illustrates the three different methods permitted to prevent combustible dust from entering the dust-ignitionproof enclosure through the raceway.

In Class II, Division 2 locations, the enclosures must be dusttight, which means that they must be, in accordance with the definition in Article 100, “so constructed that dust will not enter the enclosing case under specified test conditions.”

The *NEC*[®] permits a raceway extending from the dust-ignitionproof enclosure horizontally and downward equivalent to the permitted methods in Sections 502.15(2) or 502.15(3).

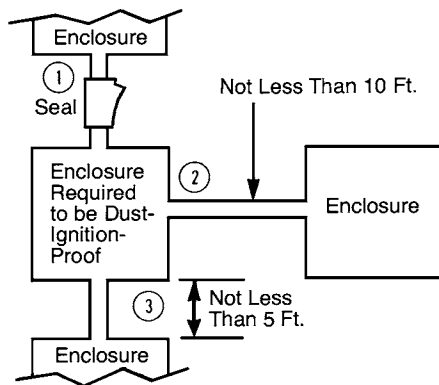

FIG. 1

The second paragraph of Section 502.15 addresses the situation where the enclosure that is not dust-ignitionproof is located in an unclassified area. In this case, no seal is required and the raceway can be any length. The reason for this is that dust cannot be transmitted through the raceway from the enclosure in the unclassified area, because, by definition, an unclassified area contains no combustible dust. Fig. 2 provides an example:

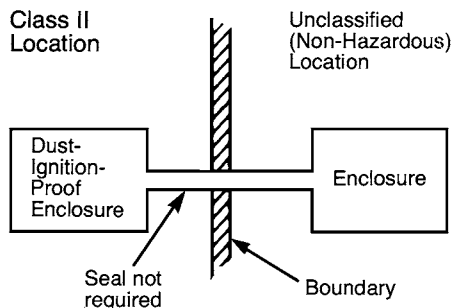

FIG. 2

NOTE: For illustrations of sealing fittings and for information on damming and pouring of sealing cement, see page 32 of this booklet. Note: Section 502.15 specifies that “Seals shall not be required to be explosionproof.”

502.25 Uninsulated Exposed Parts, Class II, Divisions 1 and 2. There shall be no uninsulated exposed parts, such as electrical conductors, buses, terminals, or components, that operate at more than 30 volts (15 volts in wet locations). These parts shall additionally be

protected by a protection technique according to 500.7(E), (F), or (G) that is suitable for the location.

These requirements clarify that uninsulated exposed parts, such as electric conductors, buses, terminals, or components, may not present a risk of electrical shock but must be protected by a protection technique according to Sections 500.7(E), 500.7(F), or 500.7(G) that is suitable for the location.



ELIMINATING DISASTERS LIKE THIS REQUIRES CAREFUL CLASSIFICATION OF AREAS AND THE USE OF THE PROPER ELECTRICAL EQUIPMENT.

502.30 Grounding and Bonding, Class II, Divisions 1 and 2. Regardless of the voltage of the electrical system, wiring and equipment in Class II, Division 1 and 2 locations shall be grounded as specified in Article 250 and in accordance with the requirements of 502.30(A) and (B).

(A) Bonding. The locknut-bushing and double-locknut types of contact shall not be depended on for bonding purposes, but bonding jumpers with proper fittings or other approved means of bonding shall be used. Such means of bonding shall apply to all intervening raceways, fittings, boxes, enclosures, and so forth, between Class II locations and the point of grounding for service equipment or point of grounding of a separately derived system.

Exception: The specific bonding means shall only be required to the nearest point where the grounded circuit conductor and the grounding electrode conductor are connected together on the line side of the building or structure disconnecting means as specified in 250.32(B) if the branch-circuit overcurrent protection is located on the load side of the disconnecting means.

(B) Types of Equipment Grounding Conductors. Liquidtight flexible metal conduit shall include an equipment bonding jumper of the wire type in compliance with 250.102.

Exception: In Class II, Division 2 locations, the bonding jumper shall be permitted to be deleted where all of the following conditions are met:

(1) Listed liquidtight flexible metal conduit 1.8 m (6 ft) or less in length, with fittings listed for grounding, is used.

(2) Overcurrent protection in the circuit is limited to 10 amperes or less.

INTERPRETATION OF ARTICLE 502: CLASS II LOCATIONS

(3) *The load is not a power utilization load.*

It is important to note that all the grounding and bonding requirements of Article 250 apply. In addition the requirements contained in Sections 502.30(A) and (B) apply to wiring and equipment in Class II, Divisions 1 and 2 locations.

These specific bonding means must be used to bond all raceways, fittings, boxes or enclosures back to the service or separately derived system in accordance with Section 250.30 supplying grounded circuit conductor. Locknut-bushing and double-locknut types of contact shall not be depended on for bonding purposes, but bonding jumpers with proper fittings or other approved means of bonding shall be used. *NEC*® Section 250.100 contains additional bonding requirements in hazardous (classified) locations.

Where flexible conduit is used as permitted in Section 502.10, an internal or external bonding jumper shall be installed in parallel with each conduit and complying with Section 250.102. In Class II, Division 2 locations, the bonding jumper may be deleted provided listed liquidtight flexible metal conduit 1.8 m (6 ft) or less in length, with fittings listed for grounding, is used; overcurrent protection in the circuit is limited to 10 amperes or less; and the load is not a power utilization load.

502.35 Surge Protection — Class II, Divisions 1 and 2. Surge arresters and surge-protective devices installed in a Class II, Division 1 location shall be in suitable enclosures. Surge-protective capacitors shall be of a type designed for specific duty.

Article 280 applies generally and in addition, surge arresters, installed in a Class II, Division 1 location, shall be in suitable enclosures. Surge-protective capacitors shall be of a type designed for specific duty.

The requirements for Multiwire Branch Circuits in a Class II, Division 1 location have been removed from this Article as the general requirements for these circuits in Section 210.4(B). See Section 90.3 “Code Arrangement”.

III. Equipment

502.100 Transformers and Capacitors.

(A) Class II, Division 1. In Class II, Division 1 locations, transformers and capacitors shall comply with 502.100(A)(1) through (A)(3).

(1) Containing Liquid That Will Burn. Transformers and capacitors containing a liquid that will burn shall be installed only in vaults complying with 450.41 through 450.48, and, in addition, (1), (2), and (3) shall apply.

(1) Doors or other openings communicating with the Division 1 location shall have self-closing fire doors on both sides of the wall, and the doors shall be carefully fitted and provided with suitable seals (such as weather stripping) to minimize the entrance of dust into the vault.

(2) Vent openings and ducts shall communicate only with the outside air.

(3) Suitable pressure-relief openings communicating with the outside air shall be provided.

(2) Not Containing Liquid That Will Burn. Transformers and capacitors that do not contain a liquid that will burn shall be installed in vaults complying with 450.41 through 450.48 or be identified as a

complete assembly, including terminal connections.

(3) Group E. No transformer or capacitor shall be installed in a Class II, Division 1, Group E location.

(B) Class II, Division 2. In Class II, Division 2 locations, transformers and capacitors shall comply with 502.100(B)(1) through (B)(3).

(1) Containing Liquid That Will Burn. Transformers and capacitors containing a liquid that will burn shall be installed in vaults that comply with 450.41 through 450.48.

(2) Containing Askarel. Transformers containing askarel and rated in excess of 25 kVA shall be as follows:

(1) Provided with pressure-relief vents

(2) Provided with a means for absorbing any gases generated by arcing inside the case, or the pressure-relief vents shall be connected to a chimney or flue that will carry such gases outside the building

(3) Have an airspace of not less than 150 mm (6 in.) between the transformer cases and any adjacent combustible material

(3) Dry-Type Transformers. Dry-type transformers shall be installed in vaults or shall have their windings and terminal connections enclosed in tight metal housings without ventilating or other openings and shall operate at not over 600 volts, nominal.

In Class II, Division 2 locations transformers and capacitors containing a liquid that will burn shall be installed in vaults that comply with Section 450.41 through 450.48. Transformers containing askarel and rated in excess of 25 kVA shall have an airspace of not less than 150 mm (6 in.) between the transformer cases and any adjacent combustible material and pressure-relief vents connected to a chimney or flue that will carry such gases outside the building or a means for absorbing any gases generated by arcing inside the case. Dry-type transformers shall operate at not over 600 volts, nominal and be installed in vaults or have their windings and terminal connections enclosed in tight metal housings without ventilating or other openings.

502.115 Switches, Circuit Breakers, Motor Controllers, and Fuses.

(A) Class II, Division 1. In Class II, Division 1 locations, switches, circuit breakers, motor controllers, fuses, push buttons, relays, and similar devices shall be provided with enclosures identified for the location.

Enclosures are required to be identified for the location for Class II, Division 1, Groups E, F, and G. See Article 100 for the definition of identified.

NEC® Section 502.115(A)(2) specifically mentions metal dusts as being extremely hazardous and requires that products used in these atmospheres have enclosures specifically identified for such locations.

In accordance with Section 502.115(A)(1), switches, circuit breakers and motor controllers, including push buttons and similar devices used in Class II, Division 1 locations must be provided with dust-ignitionproof enclosures and identified for such locations.

Note: It is not necessary for a Class II enclosure with the enclosed equipment to be evaluated as a complete assembly. Class II enclosures are evaluated for their ability to prevent the entrance of dusts. This

INTERPRETATION OF ARTICLE 502: CLASS II LOCATIONS

differs from Class I enclosures, which are evaluated on their ability to withstand an explosion.

GUBBM INSTRUMENT ENCLOSURES



(B) Class II, Division 2. In Class II, Division 2 locations, enclosures for fuses, switches, circuit breakers, and motor controllers, including push buttons, relays, and similar devices, shall be dusttight or otherwise identified for the location.



APPN POWER PANEL FOR CLASS I AND CLASS II APPLICATIONS



ACSEW CUSTOM CAST CONTROL CENTER FOR CLASS I AND CLASS II APPLICATIONS

Enclosures are required to be identified for the location or be dusttight.

In Class II, Division 2 locations switching mechanisms (including overcurrent devices) associated with control transformers, solenoids, impedance coils, and resistors shall be installed in dusttight enclosures. Where the coil or winding is not located in the same enclosure they shall be provided with tight metal housings without ventilating

openings or dusttight enclosures.

Resistors and resistance devices shall be installed in dust-ignitionproof enclosures identified for Class II locations except where the maximum normal operating temperature of the resistor will not exceed 120° C

(248° F), nonadjustable resistors or resistors that are part of an automatically timed starting sequence shall be permitted to have enclosures complying with 502.120(B)(2).

502.120 Control Transformers and Resistors.

(A) Class II, Division 1. In Class II, Division 1 locations, control transformers, solenoids, impedance coils, resistors, and any overcurrent devices or switching mechanisms associated with them shall be provided with enclosures identified for the location.

The enclosure must be identified for the location regardless of the dust that is present.

(B) Class II, Division 2. In Class II, Division 2 locations, transformers and resistors shall comply with 502.120(B)(1) through (B)(3).

(1) Switching Mechanisms. Switching mechanisms (including overcurrent devices) associated with control transformers, solenoids, impedance coils, and resistors shall be provided with enclosures that are dusttight or otherwise identified for the location.

Enclosures are required to be identified for the location or be dusttight.

(2) Coils and Windings. Where not located in the same enclosure with switching mechanisms, control transformers, solenoids, and impedance coils shall be provided with enclosures that are dusttight or otherwise identified for the location.

(3) Resistors. Resistors and resistance devices shall have dust-ignitionproof enclosures that are dusttight or otherwise identified for the location.

Resistors are required to be installed in enclosures that are identified for Class II, Division 1.

502.125 Motors and Generators.

(A) Class II, Division 1. In Class II, Division 1 locations, motors, generators, and other rotating electrical machinery shall be in conformance with either of the following:

- (1) Identified for the location
- (2) Totally enclosed pipe-ventilated

All motors, generators, and other rotating electrical machinery installed in a Class II, Division 1 location shall be identified for Class II, Division 1 locations, or be totally enclosed pipe-ventilated to ensure they have been evaluated for their function to prevent the entrance of dust and to prevent arc and sparks from escaping that could result in the ignition of the surrounding dust atmosphere.

Note: It is also required to maintain compliance with the equipment Class II temperatures in accordance with Table 500.8(D)(2).

The Motor starter and circuit breaker enclosures installed where

INTERPRETATION OF ARTICLE 502: CLASS II LOCATIONS

combustible dusts of an electrically conductive nature may be present, shall be provided with identified dust-ignitionproof enclosures (Class II, Division 1).

STARTERS ONLY.

Both Magnetic and Manual Motor Starters provide across-the-line starting of polyphase AC induction motors, plus overload protection for motors and equipment. Starters are furnished with 3-pole block type overload relay; other types available on special order.

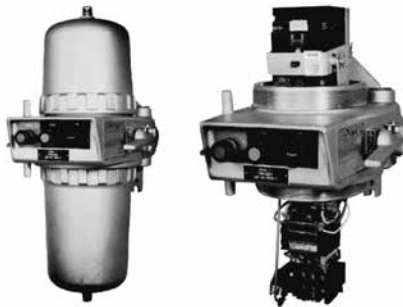

COMBINATION FULL VOLTAGE MOTOR STARTERS
WITH THERMAL MAGNETIC BREAKERS

BREAKERS ONLY.

Thermal magnetic circuit breakers provide overcurrent and short circuit protection, plus safe disconnect. Thermal time delay offers overload protection for service entrance, feeder, or branch circuits used for lighting, heating, motors and equipment.



AEB MOTOR STARTER

(B) Class II, Division 2. In Class II, Division 2 locations, motors, generators, and other rotating electrical equipment shall be totally enclosed nonventilated, totally enclosed pipe-ventilated, totally enclosed water-air-cooled, totally enclosed fan-cooled or dust-ignitionproof for which maximum full-load external temperature shall be in accordance with 500.8(D)(2) for normal operation when operating in free air (not dust blanketed) and shall have no external openings.

Exception: If the authority having jurisdiction believes accumulations of nonconductive, nonabrasive dust will be moderate and if machines can be easily reached for routine cleaning and maintenance, the following shall be permitted to be installed:

(1) *Standard open-type machines without sliding contacts, centrifugal or other types of switching mechanism (including motor overcurrent, overloading, and overtemperature devices), or integral resistance devices*

(2) *Standard open-type machines with such contacts, switching mechanisms, or resistance devices enclosed within dusttight housings without ventilating or other openings*

(3) *Self-cleaning textile motors of the squirrel-cage type*

All motors, generators, and other rotating electrical machinery installed in a Class II, Division 2 location must be totally enclosed nonventilated, totally enclosed, pipe-ventilated, totally enclosed water-air-cooled, totally enclosed fan-cooled or dust-ignitionproof with no external openings. The maximum full-load external temperature cannot exceed the values in Table 500.8(D)(2) for normal operation in free air (not dust blanketed). If the authority having jurisdiction (AHJ) believes accumulations of nonconductive, nonabrasive dust will be moderate and if machines can be easily reached for routine cleaning and maintenance the AHJ may permit standard open-type machines without sliding contacts, centrifugal or other types of switching mechanism (including motor overcurrent, overloading, and overtemperature devices), or integral resistance devices or standard open type machines with such contacts, switching mechanisms, or resistance devices enclosed within dusttight housing ventilation or other openings or self-cleaning textile motors of the squirrel-cage type.

502.128 Ventilating Piping. Ventilating pipes for motors, generators, or other rotating electrical machinery, or for enclosures for electrical equipment, shall be of metal not less than 0.53 mm (0.021 in.) in thickness or of equally substantial noncombustible material and shall comply with all of the following:

- (1) Lead directly to a source of clean air outside of buildings
- (2) Be screened at the outer ends to prevent the entrance of small animals or birds
- (3) Be protected against physical damage and against rusting or other corrosive influences

Ventilating pipes shall also comply with 502.128(A) and (B).

(A) Class II, Division 1. In Class II, Division 1 locations, ventilating pipes, including their connections to motors or to the dust-ignitionproof enclosures for other equipment, shall be dusttight throughout their length. For metal pipes, seams and joints shall comply with one of the following:

- (1) Be riveted and soldered
- (2) Be bolted and soldered
- (3) Be welded
- (4) Be rendered dusttight by some other equally effective means

(B) Class II, Division 2. In Class II, Division 2 locations, ventilating pipes and their connections shall be sufficiently tight to prevent the entrance of appreciable quantities of dust into the ventilated equipment or enclosure and to prevent the escape of sparks, flame, or burning material that might ignite dust accumulations or combustible material in the vicinity. For metal pipes, lock seams and riveted or welded joints shall be permitted; and tight-fitting slip joints shall be permitted where some flexibility is necessary, as at connections to motors.

INTERPRETATION OF ARTICLE 502: CLASS II LOCATIONS

All ventilating piping from electrical equipment such as enclosures, motors and generators are required to be manufactured from 0.021 metal (0.53 mm) or equal. The piping must comply with Section 502.128(A) for Class II, Division 1 and Section 501.128(B) for Class II, Division 2.

502.130 Luminaires.

(A) Class II, Division 1. In Class II, Division 1 locations, luminaires for fixed and portable lighting shall comply with 502.130(A)(1) through (A)(4).

(1) Marking. Each luminaire shall be identified for the location and shall be clearly marked to indicate the type and maximum wattage of the lamp for which it is designed.

Not only is the maximum wattage of the lamp required to be marked on the luminaire, but also the lamp type that is suitable for use.

ALL LUMINAIRES ILLUSTRATED ON THIS PAGE ARE DESIGNED WITH FLOWING VERTICAL LINES TO MINIMIZE DEPOSITS OF DUST. ALL LUMINAIRES ARE DUST-IGNITIONPROOF, MEETING THE REQUIREMENTS OF SECTION 502.130(A)(1). THE LUMINAIRES ALSO COMPLY WITH THIS ARTICLE IN REGARD TO PROVIDING NAMEPLATES THAT SPECIFY MAXIMUM WATTAGE FOR WHICH THE LUMINAIRES ARE APPROVED. APPROVALS FOR CLASS II ARE BASED ON THE ASSUMPTION THAT THE LUMINAIRES WILL BE MOUNTED IN A VERTICAL POSITION.



CODE*MASTER JR.

CODE*MASTER

A-51



VRS/DRS



MERCMASTER III

MERCMASTER III
LOW PROFILES

MERCMASTER LED

SEE PAGE 39 FOR COMPLETE HANGING METHODS.

(2) Physical Damage. Each luminaire shall be protected against physical damage by a suitable guard or by location.

(3) Pendant Luminaires. Pendant luminaires shall be suspended by threaded rigid metal conduit stems, by threaded steel intermediate metal conduit stems, by chains with approved fittings, or by other approved means. For rigid stems longer than 300 mm (12 in.), permanent and

effective bracing against lateral displacement shall be provided at a level not more than 300 mm (12 in.) above the lower end of the stem, or flexibility in the form of a fitting or a flexible connector listed for the location shall be provided not more than 300 mm (12 in.) from the point of attachment to the supporting box or fitting. Threaded joints shall be provided with set screws or other effective means to prevent loosening. Where wiring between an outlet box or fitting and a pendant luminaire is not enclosed in conduit, flexible cord listed for hard usage shall be permitted to be used in accordance with 502.10(A)(2)(5). Flexible cord shall not serve as the supporting means for a luminaire.

SUGGESTED HANGING METHODS - CLASS II, DIVISION 1 AND 2

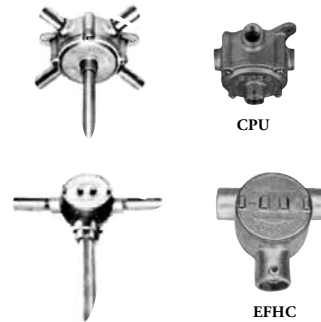

SEE PAGE 39 FOR COMPLETE HANGING METHODS.

(4) Supports. Boxes, box assemblies, or fittings used for the support of luminaires shall be identified for Class II locations.

(B) Class II, Division 2. In Class II, Division 2 locations, luminaires shall comply with 502.130(B)(1) through (B)(5).

(1) Portable Lighting Equipment. Portable lighting equipment shall be identified for the location. They shall be clearly marked to indicate the maximum wattage of lamps for which they are designed.

(2) Fixed Lighting. Luminaires for fixed lighting shall be provided with enclosures that are dusttight or otherwise identified for the location. Each luminaire shall be clearly marked to indicate the maximum wattage of the lamp that shall be permitted without exceeding an exposed surface temperature in accordance with 500.8(D)(2) under normal conditions of use.

This section requires a rating of "dusttight" for the fixed lighting enclosure (ballast tank). Older editions of the code described the intent of minimizing the deposits of dust onto the lamp and lamp holder. It is important to note that this objective rule is now imposed on the requirements for coils and windings and contacts.

(3) Physical Damage. Luminaires for fixed lighting shall be protected from physical damage by suitable guards or by location.

(4) Pendant Luminaires. Pendant luminaires shall be suspended by threaded rigid metal conduit stems, by threaded steel intermediate metal conduit stems, by chains with approved fittings, or by other approved means. For rigid stems longer than 300 mm (12 in.), permanent and effective bracing against lateral displacement shall be provided at a level not more than 300 mm (12 in.) above the lower end of the stem, or flexibility in the form of an identified fitting or a flexible connector shall be provided not more than 300 mm (12 in.) from the point of

INTERPRETATION OF ARTICLE 502: CLASS II LOCATIONS

attachment to the supporting box or fitting. Where wiring between an outlet box or fitting and a pendant luminaire is not enclosed in conduit, flexible cord listed for hard usage shall be permitted if terminated with a listed cord connector that maintains the protection technique. Flexible cord shall not serve as the supporting means for a luminaire.

This Section requires the cord connector to be listed for use with hard usage cord.

(5) Electric-Discharge Lamps. Starting and control equipment for electric-discharge lamps shall comply with the requirements of 502.120(B).

In Class II locations each luminaire must be identified and marked with the maximum size lamp permitted in watts, or designed to minimize the deposit of dust on lamps and to prevent the escape of sparks, burning material, or hot metal. Electric-discharge lamps and starting and control equipment for electric-discharge lamps must comply with 502.120(B) and must be marked and identified for the specific location where dust from magnesium, aluminum, aluminum bronze powders, or other metals of similarly hazardous characteristics may be present. All boxes, box assemblies, or fittings used to support luminaires are required to be identified for Class II locations.

Note: The minimum ignition temperatures of specific dusts are contained in NFPA 499 (Recommended Practice for the Classification of Combustible Dusts and of Hazardous (Classified) Locations for Electrical Installations in Chemical Process Areas).

502.135 Utilization Equipment.

(A) Class II, Division 1. In Class II, Division 1 locations, all utilization equipment shall be identified for the location.

In Class II, Division 1 locations, utilization equipment must be identified for Class II locations and where dust from magnesium, aluminum, aluminum bronze powders, or other metals of similarly hazardous characteristics may be present, such equipment shall be identified for the specific location.

(B) Class II, Division 2. In Class II, Division 2 locations, all utilization equipment shall comply with 502.135(B)(1) through (B)(4).

(1) Heaters. Electrically heated utilization equipment shall be identified for the location.

Exception: Metal-enclosed radiant heating panel equipment shall be permitted to be dusttight and marked in accordance with 500.8(C).

In Class II, Division 2 locations, electrically heated utilization equipment must be identified for a Class II location except for Metal-enclosed radiant heating panel equipment which is permitted to be dusttight where it is marked in accordance with Section 500.8(C).

Note: Table 500.8(C) contains the maximum surface temperatures for the "T" codes that may appear on the utilization equipment.

(2) Motors. Motors of motor-driven utilization equipment shall comply with 502.125(B).

(3) Switches, Circuit Breakers, and Fuses. Enclosures for switches, circuit breakers, and fuses shall comply with 502.115(B).

The enclosure is required to be either identified for the location by reference to section 502.115(B) or be dusttight.

MOTOR STARTERS & BREAKERS—CLASS II, DIVISION 1 AND 2.

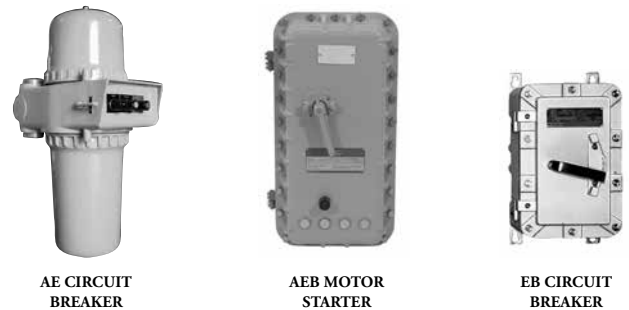

(4) Transformers, Solenoids, Impedance Coils, and Resistors. Transformers, solenoids, impedance coils, and resistors shall comply with 502.120(B).

Dusttight enclosures or enclosures identified for the location are required for switches, circuit breakers, and fuses. Motors are required to comply with Section 502.125(B) and control transformers, solenoids, impedance coils, and resistors must comply with Section 502.120(B).

All luminaires illustrated in this section are designed with flowing vertical lines to minimize deposits of dust. All luminaires are dust-ignitionproof, meeting the requirements of Section 502.130(A)(1). The luminaires also comply with this Article in regard to providing nameplates that specify maximum wattage for which the luminaires are approved. Approvals for Class II are based on the assumption that the luminaires will be mounted in a vertical position.

502.140 Flexible Cords — Class II, Divisions 1 and 2.

(A) Permitted Uses. Flexible cords used in Class II locations shall comply with all of the following:

(1) For connection between portable lighting equipment or other portable utilization equipment and the fixed portion of its supply circuit. The flexible cord shall be attached to the utilization equipment with a cord connector listed for the protection technique of the equipment wiring compartment. An attachment plug in accordance with 502.145 shall be employed.

(2) Where flexible cord is permitted by 502.10(A)(2) for fixed and mobile electrical utilization equipment; where the flexible cord is protected by location or by a suitable guard from damage; and only in an industrial establishment where conditions of maintenance and engineering supervision ensure that only qualified persons install and service the installation.

(3) For electric submersible pumps with means for removal without entering the wet-pit. The extension of the flexible cord within a suitable raceway between the wet-pit and the power source shall be permitted.

(4) For electric mixers intended for travel into and out of open-type mixing tanks or vats.

(5) For temporary portable assemblies consisting of receptacles, switches, and other devices that are not considered portable utilization equipment but are individually listed for the location.

(B) Installation. Where flexible cords are used, the cords shall comply with all of the following:

INTERPRETATION OF ARTICLE 502: CLASS II LOCATIONS

(1) Be of a type listed for extra-hard usage.

Exception: Flexible cord listed for hard usage as permitted by 502.130(A)(3) and (B)(4).

(2) Contain, in addition to the conductors of the circuit, an equipment grounding conductor complying with 400.23.

(3) Be supported by clamps or by other suitable means in such a manner that there will be no tension on the terminal connections.

(4) In Division 1 locations, the cord shall be terminated with a cord connector listed for the location or a listed cord connector installed with a seal listed for the location. In Division 2 locations, the cord shall be terminated with a listed dusttight cord connector.

(5) Be of continuous length. Where 502.140(A)(5) is applied, cords shall be of continuous length from the power source to the temporary portable assembly and from the temporary portable assembly to the utilization equipment.

This Section now addresses the requirements for Flexible Cords in a Class II, Division 1 or 2 location in a similar manner/context that Section 501.140 addresses the requirements for Flexible Cords in a Class I, Division 1 or 2 location.

Since this section contains the requirement for both Class II, Division 1 and 2 the specific sealing requirements for each Division are addressed. If the cord is terminating into Class II, Division 1 equipment then the cord connector needs to be listed for the location or it may simply be listed for use with flexible cord and then it would have to go through a listed sealing fitting. If the cord is terminated into Class II, Division 2 equipment then the cord connector needs only to be listed for use with flexible cord.

Flexible cords used with plugs and cable connectors are required by Section 502.140 to be listed for "extra hard usage" (see Table 400.4) and include grounding conductor identified with markings specified in *NEC*® Section 400.23. Plugs and cord connectors must have cable clamps of such strength that tension on the terminal connections are eliminated, complying with Section 502.140(4). Listed flexible cord for hard usage is permitted in accordance with Sections 502.130(A)(3) and 502.130(B)(4).

502.145 Receptacles and Attachment Plugs. Receptacles and attachment plugs shall be identified for the location.

(A) Class II, Division 1.

(1) Receptacles. In Class II, Division 1 locations, receptacles shall be part of the premises wiring.

(2) Attachment Plugs. Attachment plugs shall be of the type that provides for connection to the equipment grounding conductor of the flexible cord.

(B) Class II, Division 2.

(1) Receptacles. In Class II, Division 2 locations, receptacles shall be part of the premises wiring.

(2) Attachment Plugs. Attachment plugs shall be of the type that provides for connection to the equipment grounding conductor of the flexible cord.

Section 502.145(B) specifically requires that receptacles and plugs used in Class II, Division 2 locations "be so designed that connection to the supply circuit cannot be made or broken while live parts are exposed." For Class II, Division 1 locations, this same requirement must certainly apply, although the *NEC*® does not state it explicitly. Section 502.145(A) requires receptacles and attachment plugs to be identified for Class II, Division 1 locations. Appleton receptacles and plugs for hazardous locations are designed to prevent ignition of dusts in the surrounding atmosphere.

The Section also acknowledges that the Receptacles are part of the premises wiring and the Attachment Plugs is part of the utilization equipment. This was not clear in previous editions of the Code.

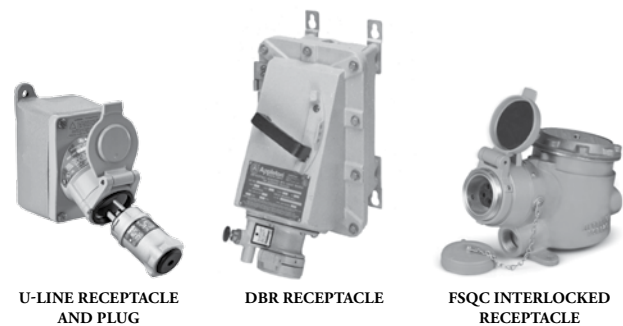

SAFETY CONSTRUCTION DESIGN OF APPLETON RECEPTACLES AND PLUGS.

Live parts of Appleton receptacles and plugs are electrically dead during plug insertion and withdrawal. In the FSQX, FSQC, EBR, EBRH, DBR, U-Line® and N1 and N2 receptacles, the plug cannot be inserted unless the switch is in the OFF position and cannot be withdrawn with the receptacle in the ON position.

502.150 Signaling, Alarm, Remote-Control, and Communications Systems; and Meters, Instruments, and Relays.

Informational Note: See Article 800 for rules governing the installation of communications circuits.

(A) Class II, Division 1. In Class II, Division 1 locations, signaling, alarm, remote-control, and communications systems; and meters, instruments, and relays shall comply with 502.150(A)(1) through (A)(3).

(1) Contacts. Switches, circuit breakers, relays, contactors, fuses and current-breaking contacts for bells, horns, howlers, sirens, and other devices in which sparks or arcs may be produced shall be provided with enclosures identified for the location.

Exception: Where current-breaking contacts are immersed in oil or where the interruption of current occurs within a chamber sealed against the entrance of dust, enclosures shall be permitted to be of the general-purpose type.

(2) Resistors and Similar Equipment. Resistors, transformers, choke coils, rectifiers, thermionic tubes, and other heat-generating equipment

INTERPRETATION OF ARTICLE 502: CLASS II LOCATIONS

shall be provided with enclosures identified for the location.

Exception: Where resistors or similar equipment are immersed in oil or enclosed in a chamber sealed against the entrance of dust, enclosures shall be permitted to be of the general-purpose type.

(3) Rotating Machinery. Motors, generators, and other rotating electrical machinery shall comply with 502.125(A).

(B) Class II, Division 2. In Class II, Division 2 locations, signaling, alarm, remote-control, and communications systems; and meters, instruments, and relays shall comply with 502.150(B)(1) through (B)(4).

(1) Contacts. Contacts shall comply with 502.150(A)(1) or shall be installed in enclosures that are dusttight or otherwise identified for the location.

Exception: In nonincendive circuits, enclosures shall be permitted to be of the general-purpose type.

(2) Transformers and Similar Equipment. The windings and terminal connections of transformers, choke coils, and similar equipment shall comply with 502.120(B)(2).

(3) Resistors and Similar Equipment. Resistors, resistance devices, thermionic tubes, rectifiers, and similar equipment shall comply with 502.120(B)(3).

(4) Rotating Machinery. Motors, generators, and other rotating electrical machinery shall comply with 502.125(B).

Meters, instruments and relays for Class II, Division 1 locations must be provided with enclosures identified for such locations. Wiring methods must comply with the requirements in Sections 502.150(A)(1) through 502.150(A)(4) for Class II, Division 1 locations and Sections 502.150(B)(1) through 502.150(B)(4) for Class II, Division 2 locations.

Note: Where Group E dusts are present, there are only Class II, Division 1 locations. Equipment used where metal dusts (which are highly electrically conductive) are present must be identified for the specific conditions, in accordance with Section 502.150(A)(5).

For Class II, Division 2 locations, the enclosures must be dusttight or identified for Class II, Division 2. Nonincendive circuits may be contained in general purpose type enclosures. Resistors must have enclosures identified for Class II, Division 1.



GRAIN ELEVATOR — CLASS II, DIVISIONS 1 AND 2.

NOTES:

INTERPRETATION OF ARTICLE 503: CLASS III LOCATIONS

CHANGES TO ARTICLE 503

The following Article 503 sections have been revised during the 2014 *NEC*® Code cycle. These changes are those that are substantive and should be noted. This list does not include those changes that are editorial in nature.

Underlined text indicates a section that has been revised from the previous *NEC*® edition. It is not intended to indicate legislation text detailing the word-for-word revisions to the section. Where minor revisions have been made to a section, these will include underlined text for select words to indicate the minor revision.

- **Section 503.5**
General
- **Section 503.10(A)(1)(4)**
Wiring Methods. Class III, Division 1. General. Type TC-ER Cable
- **Section 503.10(A)(3)(6)**
Wiring Methods. Class III, Division 1. Flexible Connections. Elevator Cable

All Appleton® products suitable for Class II, Division 1 and 2, Group G, are also suitable for Class III, Divisions 1 and 2.

UL states that “equipment listed for Class II, Group G hazardous locations is also suitable for use in Class III locations, except fan-cooled type motors where there is a very large amount of lint or combustible Flyings.”

Class III location requirements are basically the same as for Class II, except that Class III is less restrictive under some conditions. The following is a description of the basic similarities and differences:

Equipment installed in Class III locations shall be able to function at full rating without developing surface temperatures high enough to cause excessive dehydration gradual carbonization or excessive drying that may result in the material becoming susceptible to spontaneous ignition. Equipment that may be overloaded such as motor and transformers must not exceed the maximum operating temperatures listed in 503.5 in such locations. The maximum surface temperatures permitted are 165 °C for equipment not subject to overload and 120 °C for equipment subject to overload, such as motors and power transformers (same as for Class II, Division 1, Group G). Dusttight enclosures are required in Class III, Division 1 and 2 locations, as they are for most equipment in Class II, Division 2 locations.

I. General

503.1 Scope. Article 503 covers the requirements for electrical and electronic equipment and wiring for all voltages in Class III, Division 1 and 2 locations where fire or explosion hazards may exist due to ignitable fibers/flyings.

503.5 General. Equipment installed in Class III locations shall be able to function at full rating without developing surface temperatures high enough to cause excessive dehydration or gradual carbonization of accumulated fibers/flyings. Organic material that is carbonized or excessively dry is highly susceptible to spontaneous ignition. The maximum surface temperatures under operating conditions shall not exceed 165°C (329°F) for equipment that is not subject to overloading, and 120°C (248°F) for equipment (such as motors or power transformers) that may be overloaded. In a Class III, Division 1 location, the operating temperature shall be the temperature of

CLASS III AREAS DEFINED

LOCATIONS ARE THOSE THAT ARE HAZARDOUS BECAUSE OF THE PRESENCE OF EASILY IGNITIBLE FIBERS OR FLYINGS, BUT IN WHICH SUCH FIBERS OR FLYINGS ARE NOT LIKELY TO BE IN SUSPENSION IN THE AIR IN QUANTITIES SUFFICIENT TO PRODUCE IGNITIBLE MIXTURES. CLASS III, DIVISION 1 IS A LOCATION IN WHICH EASILY IGNITIBLE FIBERS OR MATERIALS PRODUCING COMBUSTIBLE FLYINGS ARE HANDLED, MANUFACTURED, OR USED.

CLASS III, DIVISION 2. IS A LOCATION IN WHICH EASILY IGNITIBLE FIBERS ARE STORED OR HANDLED OTHER THAN IN THE PROCESS OF MANUFACTURE.



CLASS III, DIVISION 1 MANUFACTURING AREA.

THESE VIEWS OF A MATTRESS FACTORY ILLUSTRATE THE BASIC DIFFERENCES BETWEEN DIVISION 1 AND DIVISION 2 IN CLASS III LOCATIONS. LEFT, THE LOCATION IS DIVISION 1 BECAUSE COMBUSTIBLE FIBERS OR FLYINGS ARE NORMALLY PRESENT DURING THE MANUFACTURING PROCESS. BELOW (RIGHT), THE LOCATION IS DIVISION 2 BECAUSE COMBUSTIBLE FIBERS OR FLYINGS ARE NOT NORMALLY PRODUCED IN SUFFICIENT QUANTITIES TO PRODUCE IGNITIBLE MIXTURES DURING STORAGE.



CLASS III, DIVISION 2 STORAGE AREA.

INTERPRETATION OF ARTICLE 503: CLASS III LOCATIONS

the equipment when blanketed with the maximum amount of dust (simulating fibers/flyings) that can accumulate on the equipment.

Informational Note: For electric trucks, see NFPA 505- 2013, *Fire Safety Standard for Powered Industrial Trucks Including Type Designations, Areas of Use, Conversions, Maintenance, and Operation*.

The product listing standards for Class III, Division 1 equipment requires that the temperature class and/or operating temperature be determined when the equipment is covered with the maximum amount of dust to simulate fibers and flyings. Listed equipment for Class III, Division 1 have been evaluated in accordance with this requirement. This is not a new requirement in the product listing standards.

The general rules in *NEC*® chapters one through four apply to the electronic wiring and equipment in locations classified as Class III unless modified by Article 503.

The rules in Article 500 also apply to Article 503.

503.6 Zone Equipment. Equipment listed and marked in accordance with 506.9(C)(2) for Zone 20 locations and with a temperature class of not greater than T120°C (for equipment that may be overloaded) or not greater than T165°C (for equipment not subject to overloading) shall be permitted in Class III, Division 1 locations.

Equipment listed and marked in accordance with 506.9(C)(2) for Zone 20, 21, or 22 locations and with a temperature class of not greater than T120°C (for equipment that may be overloaded) or not greater than T165°C (for equipment not subject to overloading) shall be permitted in Class III, Division 2 locations.

Listed equipment for Zone 20 is permitted to be installed in Class III, Division 1 and 2 locations. In addition, equipment that is rated as Zone 20, 21, or 22 are suitable for installation in Class III, Division 2 locations. This change reflected that the Code already permits Zone 20, 21, and 22 locations to be alternatively classified as an appropriate Class III location, therefore the equipment is considered to meet the intended function based on their Zone 20, 21, or 22 listed rating.

II. Wiring

503.10 Wiring Methods. Wiring methods shall comply with 503.10(A) or (B).

(A) Class III, Division 1.

(1) General. In Class III, Division 1 locations, the wiring method shall be in accordance with (1) through (4):

(1) Rigid metal conduit, Type PVC conduit, Type RTRC conduit, intermediate metal conduit, electrical metallic tubing, dusttight wireways, or Type MC or MI cable with listed termination fittings.

(2) Type PLTC and Type PLTC-ER cable in accordance with the provisions of Article 725 including installation in cable tray systems. The cable shall be terminated with listed fittings.

(3) Type ITC and Type ITC-ER cable as permitted in 727.4 and terminated with listed fittings.

(4) Type MC, MI, TC, or TC-ER cable installed in ladder, ventilated trough, or ventilated channel cable trays in a single layer, with a space not less than the larger cable diameter between the two adjacent cables,

shall be the wiring method employed. The cable shall be terminated with listed fittings.

Exception to (4): Type MC cable listed for use in Class II, Division 1 locations shall be permitted to be installed without the spacings required by 503.10(A)(1)(4).

This Section now also permits Type TC-ER (Extended Run) cable in Class III, Division 1 locations. All these cables are required to be terminated with listed fittings. This means that the fitting is specifically listed for use with the cable type. It does not require that the fittings be “listed for the location”.

(2) Boxes and Fittings. All boxes and fittings shall be dusttight.

(3) Flexible Connections. Where necessary to employ flexible connections, one or more of the following shall be permitted:

(1) Dusttight flexible connectors

(2) Liquidtight flexible metal conduit with listed fittings,

(3) Liquidtight flexible nonmetallic conduit with listed fittings,

(4) Interlocked armor Type MC cable having an overall jacket of suitable polymeric material and installed with listed dusttight termination fittings

(5) Flexible cord in compliance with 503.140

Informational Note: See 503.30(B) for grounding requirements where flexible conduit is used.

(6) For elevator use, an identified elevator cable of Type EO, ETP, or ETT, shown under the “use” column in Table 400.4 for “hazardous (classified) locations” and terminated with listed dusttight fittings.

The requirements for Flexible Connections are basically the same for Class III as for Class II, except as noted in the Exception to Section 503.10(B) for Class III, Division 2 locations. The Section permits Type MC cable that employs an overall jacket of suitable polymeric material to be used in Class III, Division 1 location where flexible connections are required. In addition Elevator Cables are now permitted with fittings that are listed for the specific type of elevator cable and that will exclude dust from entering.

(4) Nonincendive Field Wiring. Nonincendive field wiring shall be permitted using any of the wiring methods permitted for unclassified locations. Nonincendive field wiring systems shall be installed in accordance with the control drawing(s). Simple apparatus, not shown on the control drawing, shall be permitted in a nonincendive field wiring circuit, provided the simple apparatus does not interconnect the nonincendive field wiring circuit to any other circuit.

Informational Note: Simple apparatus is defined in 504.2.

Separate nonincendive field wiring circuits shall be installed in accordance with one of the following:

(1) In separate cables

(2) In multiconductor cables where the conductors of each circuit are within a grounded metal shield

(3) In multiconductor cables where the conductors of each circuit have insulation with a minimum thickness of

INTERPRETATION OF ARTICLE 503: CLASS III LOCATIONS

0.25 mm (0.01 in.)

(B) Class III, Division 2. In Class III, Division 2 locations, the wiring method shall comply with 503.10(A).

Exception: In sections, compartments, or areas used solely for storage and containing no machinery, open wiring on insulators shall be permitted where installed in accordance with Article 398, but only on condition that protection as required by 398.15(C) be provided where conductors are not run in roof spaces and are well out of reach of sources of physical damage.

The wiring methods are similar to those for Class II, Division 2 except that RNC (rigid nonmetallic conduit) and EMT (electrical metallic tubing) are permitted in Class III, Division 1. Section 503.10(A) also permits RMC (rigid metal conduit), IMC (intermediate metal conduit), dusttight wireways and MC or MI cable with listed termination fitting in those locations. All boxes and fittings are required to be dusttight. RMC and IMC do not need to be threaded, permitting the use of threadless connectors. Where necessary to use flexible connections Section 503.10(A)(2) permits the use of dusttight flexible connectors, LFMC (liquidtight flexible metallic conduit) and LFNC (liquidtight flexible nonmetallic conduit) with listed fittings (see 503.30(B) for the grounding rules where flexible conduit is used). Flexible cord in accordance with Section 503.140 is all acceptable.

Section 503.10(B) in addition to the wiring methods in Section 503.10(A) listed above, permits open wiring in accordance with Article 398 under very specific and limited conditions in Class III, Division 2 locations.

503.25 Uninsulated Exposed Parts, Class III, Divisions 1 and 2. There shall be no uninsulated exposed parts, such as electrical conductors, buses, terminals, or components, that operate at more than 30 volts (15 volts in wet locations). These parts shall additionally be protected by a protection technique according to 500.7(E), (F), or (G) that is suitable for the location.

Exception: As provided in 503.155.

503.30 Grounding and Bonding — Class III, Divisions 1 and 2. Regardless of the voltage of the electrical system, wiring and equipment in Class III, Division 1 and 2 locations shall be grounded as specified in Article 250 and with the following additional requirements in 503.30(A) and (B).

(A) Bonding. The locknut-bushing and double-locknut types of contacts shall not be depended on for bonding purposes, but bonding jumpers with proper fittings or other approved means of bonding shall be used. Such means of bonding shall apply to all intervening raceways, fittings, boxes, enclosures, and so forth, between Class III locations and the point of grounding for service equipment or point of grounding of a separately derived system.

Exception: The specific bonding means shall only be required to the nearest point where the grounded circuit conductor and the grounding electrode conductor are connected together on the line side of the building or structure disconnecting means as specified in 250.32(B) if the branch-circuit overcurrent protection is located on the load side of the disconnecting means.

(B) Types of Equipment Bonding Conductors. Liquidtight flexible metal conduit shall include an equipment bonding jumper of the wire type in compliance with 250.102.

This section clarifies that the equipment bonding jumper being described is intended to be that of the wire type.

Exception: In Class III, Division 1 and 2 locations, the bonding jumper shall be permitted to be deleted where all of the following conditions are met:

- (1) Listed liquidtight flexible metal conduit 1.8 m (6 ft) or less in length, with fittings listed for grounding, is used.*
- (2) Overcurrent protection in the circuit is limited to 10 amperes or less.*
- (3) The load is not a power utilization load.*

BONDING.

The requirements for Class III are similar to those for Class I and II in that locknut-bushing and double-locknut types of contacts are not permitted to be depended upon; bonding jumpers or other means must be used. These requirements are only required as specified in 250.100 to the point where the grounded circuit conductor is connected to the grounding electrode conductor.

EQUIPMENT GROUNDING CONDUCTORS.

NEC® Section 503.30 requirements for “Grounding Equipment” are essentially the same for Class III, Divisions 1 and 2 as for Class II, Divisions 1 and 2. In Class III locations, Section 503.30(B) is the same as Section 502.30(B) for Class II locations. However, for Class III locations, the Exception to Section 503.30(B) applies to both Division 1 and 2 locations, not just Division 2 as for Class II locations. Thus, the Exception is more permissible than the similar Exceptions for Class I and II.

III. Equipment

503.100 Transformers and Capacitors — Class III, Divisions 1 and 2. Transformers and capacitors shall comply with 502.100(B).

503.115 Switches, Circuit Breakers, Motor Controllers, and Fuses — Class III, Divisions 1 and 2. Switches, circuit breakers, motor controllers, and fuses, including pushbuttons, relays, and similar devices, shall be provided with dusttight enclosures.

Section 503.115 specifies “dusttight” enclosures only and makes no distinction between Division 1 and 2 of Class III.

503.120 Control Transformers and Resistors — Class III, Divisions 1 and 2. Transformers, impedance coils, and resistors used as, or in conjunction with, control equipment for motors, generators, and appliances shall be provided with dusttight enclosures complying with the temperature limitations in 503.5.

The requirements in Section 503.120 for transformers, impedance coils, and resistors used as or in conjunction with control equipment for motors, generators, and appliances in both Class III, Divisions 1 and 2 require that they be provided and enclosed in dusttight enclosures and that they must also comply with the temperature limitations in Section 503.5.

503.125 Motors and Generators — Class III, Divisions 1 and 2. In Class III, Divisions 1 and 2 locations, motors, generators, and other rotating machinery shall be totally enclosed nonventilated, totally enclosed pipe ventilated, or totally enclosed fan cooled.

Exception: In locations where, in the judgment of the authority having jurisdiction, only moderate accumulations of lint or flyings are likely to collect on, in, or in the vicinity of a rotating electrical machine and where such machine is readily accessible for routine cleaning and maintenance, one

INTERPRETATION OF ARTICLE 503: CLASS III LOCATIONS

of the following shall be permitted:

- (1) Self-cleaning textile motors of the squirrel-cage type
- (2) Standard open-type machines without sliding contacts, centrifugal or other types of switching mechanisms, including motor overload devices
- (3) Standard open-type machines having such contacts, switching mechanisms, or resistance devices enclosed within tight housings without ventilating or other openings

NEC® Section 503.125 avoids duplication by stating general requirements for both Divisions 1 and 2. It is apparent that the exceptions apply to Division 2 as well as Division 1. “Types Not Permitted” are not needed, as positive requirements on the types of motors that may be used is stated. Basically the requirements for motors and generators are the same for Class III, Divisions 1 and 2 as for Class II, Division 2 locations. Requirements in Class II, Division 2 locations are slightly more severe than in Class III, Division 1 locations (standard open type machines with contacts, switch mechanisms or resistance devices require “tight” enclosures rather than “dusttight” enclosures required in Class II, Division 2). Section 503.5 temperature limitations apply to Class III.

503.128 Ventilating Piping — Class III, Divisions 1 and 2. Ventilating pipes for motors, generators, or other rotating electrical machinery, or for enclosures for electric equipment, shall be of metal not less than 0.53 mm (0.021 in.) in thickness, or of equally substantial noncombustible material, and shall comply with the following:

- (1) Lead directly to a source of clean air outside of buildings
- (2) Be screened at the outer ends to prevent the entrance of small animals or birds
- (3) Be protected against physical damage and against rusting or other corrosive influences

Ventilating pipes shall be sufficiently tight, including their connections, to prevent the entrance of appreciable quantities of fibers/flyings into the ventilated equipment or enclosure and to prevent the escape of sparks, flame, or burning material that might ignite accumulations of fibers/flyings or combustible material in the vicinity. For metal pipes, lock seams and riveted or welded joints shall be permitted; and tight-fitting slip joints shall be permitted where some flexibility is necessary, as at connections to motors.

NEC® Section 503.128 requirements for Ventilating Piping are similar to those for Class III as for Class II. Section 503.128 lists the same material and installation requirements for Class III as for Class II, and joint requirements are the same as for Class II, Division 2.

503.130 Luminaires — Class III, Divisions 1 and 2.

(A) Fixed Lighting. Luminaires for fixed lighting shall provide enclosures for lamps and lampholders that are designed to minimize entrance of fibers/flyings and to prevent the escape of sparks, burning material, or hot metal. Each luminaire shall be clearly marked to show the maximum wattage of the lamps that shall be permitted without exceeding an exposed surface temperature of 165°C (329°F) under normal conditions of use.

(B) Physical Damage. A luminaire that may be exposed to physical damage shall be protected by a suitable guard.

(C) Pendant Luminaires. Pendant luminaires shall be suspended

by stems of threaded rigid metal conduit, threaded intermediate metal conduit, threaded metal tubing of equivalent thickness, or by chains with approved fittings. For stems longer than 300 mm (12 in.), permanent and effective bracing against lateral displacement shall be provided at a level not more than 300 mm (12 in.) above the lower end of the stem, or flexibility in the form of an identified fitting or a flexible connector shall be provided not more than 300 mm (12 in.) from the point of attachment to the supporting box or fitting.

FIXTURES FOR CLASS III, DIVISION 1 AND 2.



(D) Portable Lighting Equipment. Portable lighting equipment shall be equipped with handles and protected with substantial guards. Lampholders shall be of the unswitched type with no provision for receiving attachment plugs. There shall be no exposed current-carrying metal parts, and all exposed non-current-carrying metal parts shall be grounded. In all other respects, portable lighting equipment shall comply with 503.130(A).

NEC® Section 503.130 (A) specifies that enclosures must be designed to “minimize the entrance of fibers and flyings”. Maximum surface temperature, not lamp temperature, is the same for Class III, Divisions 1 and 2 as for Class II, Division 2, Group G; (165 °C). Section 503.130(C) lists the means by which pendant fixtures may be suspended. Portable luminaires are covered in Section 503.130(D) which states that (1) there shall be no exposed current carrying parts and (2) exposed noncurrent carrying parts shall be grounded. This wording is intended to emphasize these two important requirements in accordance with Article 410.

503.135 Utilization Equipment — Class III, Divisions 1 and 2.

(A) Heaters. Electrically heated utilization equipment shall be identified for Class III locations.

(B) Motors. Motors of motor-driven utilization equipment shall comply with 503.125.

(C) Switches, Circuit Breakers, Motor Controllers, and Fuses. Switches, circuit breakers, motor controllers, and fuses shall comply with 503.115.

Electrically heated utilization equipment (heaters) must be identified for Class III locations. Motor requirements are slightly more severe

INTERPRETATION OF ARTICLE 503: CLASS III LOCATIONS

for Class II, Division 2 locations than for Class III, Division 1 and 2 locations [see Sections 502.125(B) and 502.135(B)]. Enclosures for switches, circuit breakers, motor controllers and fuses must have dusttight covers.

503.140 Flexible Cords — Class III, Divisions 1 and 2. Flexible cords shall comply with the following:

- (1) Be of a type listed for extra-hard usage
- (2) Contain, in addition to the conductors of the circuit, an equipment grounding conductor complying with 400.23
- (3) Be supported by clamps or other suitable means in such a manner that there will be no tension on the terminal connections
- (4) Be terminated with a listed dusttight cord connector.

Flexible cords must be a type listed for extra-hard usage, the same as Class II, Division 1 and 2 (Section 502.140), except that seals and dust-ignitionproof enclosures are not required in Class III, Division 1 and 2 locations. A suitable means must however be provided to prevent the entrance of fibers and flyings. This section requires that the cord connector be listed. This cord connector is not required to be “listed for the location”.

503.145 Receptacles and Attachment Plugs — Class III, Divisions 1 and 2. Receptacles and attachment plugs shall be of the grounding type, shall be designed so as to minimize the accumulation or the entry of fibers/flyings, and shall prevent the escape of sparks or molten particles.



MD2SR CAST ALUMINUM RECEPTACLE WITH INTERLOCKED SWITCH AVAILABLE FUSED OR NON-FUSED. WHEN THESE RECEPTACLES ARE USED IN CLASS III, DIVISION 1 OR 2 LOCATIONS, THE CONDITIONS IMPOSED BY 503.145 EXCEPTION MUST BE MET.

Exception: In locations where, in the judgment of the authority having jurisdiction, only moderate accumulations of lint or flyings are likely to collect in the vicinity of a receptacle, and where such receptacle is readily accessible for routine cleaning, general-purpose grounding-type receptacles mounted so as to minimize the entry of fibers/flyings shall be permitted.

Receptacles and attachment plugs in Class III, Division 1 and 2 are required to be of the grounding type and be designed so that the entry of fibers and flyings will be minimized and sparks or molten particles cannot escape. Where it can be determined that only moderate accumulations of lint or flyings will be likely to collect in the vicinity

of a receptacle, and where such a receptacle is readily accessible for routine cleaning, the authority having jurisdiction may permit general-purpose grounding-type receptacles mounted so as to minimize the entry of fibers and flyings.

RECEPTACLES FOR CLASS III, DIVISION 1 AND 2.



POWERTITE

GENERAL PURPOSE RECEPTACLES ARE SUITABLE FOR CLASS III, DIVISION 1 IF THEY MEET THE CONDITIONS IMPOSED BY 503.145 EXCEPTION.

503.150 Signaling, Alarm, Remote-Control, and Local Loudspeaker Intercommunications Systems — Class III, Divisions 1 and 2. Signaling, alarm, remote-control, and local loudspeaker intercommunications systems shall comply with the requirements of Article 503 regarding wiring methods, switches, transformers, resistors, motors, luminaires, and related components.

NEC® Section 503.150 requires that these systems be installed in accordance with the component requirements in other pertinent sections of Article 503; for example the wiring methods used to supply these systems must be wired in accordance with Sections 503.10(A) and 503.10(B) and luminaires (lighting fixtures) in accordance with Section 503.130(A) through (D).

503.155 Electric Cranes, Hoists, and Similar Equipment — Class III, Divisions 1 and 2. Where installed for operation over combustible fibers or accumulations of flyings, traveling cranes and hoists for material handling, traveling cleaners for textile machinery, and similar equipment shall comply with 503.155(A) through (D).

PRODUCTS SUITABLE FOR USE IN CLASS III, DIVISION 1 AND 2.

ALL PRODUCTS SUITABLE FOR USE IN CLASS II, DIVISION 2 SHOWN ON PAGE 46 ARE ALSO SUITABLE FOR USE IN CLASS III, DIVISION 1 AND 2 LOCATIONS. THESE PRODUCTS ARE IN ADDITION TO THOSE SPECIFICALLY APPROVED FOR CLASS III, DIVISION 1 AND 2.



TMC2



CG



ST

(A) Power Supply. The power supply to contact conductors shall be electrically isolated from all other systems, ungrounded, and shall be equipped with an acceptable ground detector that gives an alarm and automatically deenergizes the contact conductors in case of a fault to ground or

INTERPRETATION OF ARTICLE 503: CLASS III LOCATIONS

gives a visual and audible alarm as long as power is supplied to the contact conductors and the ground fault remains.

(B) Contact Conductors. Contact conductors shall be located or guarded so as to be inaccessible to other than authorized persons and shall be protected against accidental contact with foreign objects.

(C) Current Collectors. Current collectors shall be arranged or guarded so as to confine normal sparking and prevent escape of sparks or hot particles. To reduce sparking, two or more separate surfaces of contact shall be provided for each contact conductor. Reliable means shall be provided to keep contact conductors and current collectors free of accumulations of lint or flyings.

(D) Control Equipment. Control equipment shall comply with 503.115 and 503.120.

503.160 Storage Battery Charging Equipment — Class III, Divisions 1 and 2. Storage battery charging equipment shall be located in separate rooms built or lined with substantial noncombustible materials. The rooms shall be constructed to prevent the entrance of ignitable amounts of flyings or lint and shall be well ventilated.

Storage battery charging equipment is now required to be located in a separate unclassified well ventilated room which must be constructed with noncombustible materials and designed to prevent the entrance of flyings or lint in ignitable quantities.

INTERPRETATION OF ARTICLE 504: INTRINSICALLY SAFE SYSTEMS

CHANGES TO ARTICLE 504

The following Article 504 sections have been revised during the 2014 *NEC*® Code cycle. These changes are those that are substantive and should be noted. This list does not include those changes that are editorial in nature.

Underlined text indicates a section that has been revised from the previous *NEC*® edition. It is not intended to indicate legislation text detailing the word-for-word revisions to the section. Where minor revisions have been made to a section, these will include underlined text for select words to indicate the minor revision.

- **Section 504.10(B) through (D)**
Equipment Installation. Location. Enclosures. Simple Apparatus
- **Section 504.30(A)(2)93**
Separation of Intrinsically Safe Conductors. Within Enclosures
- **Section 504.30(C)**
Separation of Intrinsically Safe Conductors. From Grounded Metal

The concept of intrinsic safety is based on insuring that a safe system, consisting of associated apparatus located in an unclassified location, intrinsically safe apparatus in the hazardous location, and the wiring that connects them, cannot store and release enough energy to ignite the flammable atmosphere present, either by spark ignition or by creating hot surfaces that could cause ignition.

504.1 Scope. This article covers the installation of intrinsically safe (I.S.) apparatus, wiring, and systems for Class I, II, and III locations.

Informational Note: For further information, see ANSI/ISA-RP 12.06.01-2003, *Recommended Practice for Wiring Methods for Hazardous (Classified) Locations Instrumentation — Part 1: Intrinsic Safety*.

504.2 Definitions.

Associated Apparatus. Apparatus in which the circuits are not necessarily intrinsically safe themselves but that affects the energy in the intrinsically safe circuits and is relied on to maintain intrinsic safety. Such apparatus is one of the following:

- (1) Electrical apparatus that has an alternative type of protection for use in the appropriate hazardous (classified) location
- (2) Electrical apparatus not so protected that shall not be used within a hazardous (classified) location

Informational Note No. 1: Associated apparatus has identified intrinsically safe connections for intrinsically safe apparatus and also may have connections for nonintrinsically safe apparatus.

Informational Note No. 2: An example of associated apparatus is an intrinsic safety barrier, which is a network designed to limit the energy (voltage and current) available to the protected circuit in the hazardous (classified) location, under specified fault conditions.

The function of associated apparatus in an intrinsically safe system is to limit the power supplied to the intrinsically safe apparatus

to a voltage and current level that will not ignite the flammable atmosphere. Associated apparatus is also used to separate signal lines connected to intrinsically safe apparatus from possible unprotected sources of power in the unclassified location. Associated apparatus devices are often called “barriers”. Associated apparatus is usually installed in the unclassified location, as specified in Section 504.2(2). If associated apparatus is installed in a hazardous location, it must be protected using another protection technique suitable for that hazardous location, for instance inside an explosionproof enclosure if installed in Division 1, as specified in Section 504.2(1).

Different Intrinsically Safe Circuits. Intrinsically safe circuits in which the possible interconnections have not been evaluated and identified as intrinsically safe.

Intrinsically Safe Apparatus. Apparatus in which all the circuits are intrinsically safe.

Intrinsically safe apparatus is the part of the intrinsically safe system installed in the hazardous location. It may be connected to more than one associated apparatus; for instance, one set of wires connected for power, and another set for a signal circuit. The control drawing for the intrinsically safe equipment provides the parameters of the associated apparatus that can be used for each connection.

Intrinsically Safe Circuit. A circuit in which any spark or thermal effect is incapable of causing ignition of a mixture of flammable or combustible material in air under prescribed test conditions.

Informational Note: Test conditions are described in ANSI/UL 913-2006, *Standard for Safety, Intrinsically Safe Apparatus and Associated Apparatus for Use in Class I, II, and III, Division 1, Hazardous (Classified) Locations*.

Intrinsically Safe System. An assembly of interconnected intrinsically safe apparatus, associated apparatus, and interconnecting cables, in that those parts of the system that may be used in hazardous (classified) locations are intrinsically safe circuits.

Informational Note: An intrinsically safe system may include more than one intrinsically safe circuit.

Simple Apparatus. An electrical component or combination of components of simple construction with well-defined electrical parameters that does not generate more than 1.5 volts, 100 mA, and 25 mW, or a passive component that does not dissipate more than 1.3 watts and is compatible with the intrinsic safety of the circuit in which it is used.

Informational Note: The following apparatus are examples of simple apparatus:

- (1) Passive components; for example, switches, junction boxes, resistance temperature devices, and simple semiconductor devices such as LEDs
- (2) Sources of stored energy consisting of single components in simple circuits with well-defined parameters; for example, capacitors or inductors, whose values are considered when determining the overall safety of the system
- (3) Sources of generated energy; for example, thermocouples and photocells, that do not generate more than 1.5 volts, 100 mA, and 25 mW

Any limitations on the use of simple apparatus that can be used in the hazardous location will be listed on the control drawing for the associated apparatus. In the case of using a device that will heat up, such as an RTD, care must be taken to stay below the 1.3 Watt limit to avoid creating a hot surface. Care must also be taken that the use of simple apparatus does not connect two or more intrinsically safe

INTERPRETATION OF ARTICLE 504: INTRINSICALLY SAFE SYSTEMS

circuits together in the hazardous location. This can create a situation where sufficient energy could be released to cause an ignition.

504.3 Application of Other Articles. Except as modified by this article, all applicable articles of this *Code* shall apply.

504.4 Equipment. All intrinsically safe apparatus and associated apparatus shall be listed.

Exception: Simple apparatus, as described on the control drawing, shall not be required to be listed.

Because of the extensive analysis and testing that is necessary for intrinsic safety verification, intrinsically safe apparatus and associated apparatus are required to have a third party listing. Simple apparatus would normally not be listed.

504.10 Equipment Installation.

(A) Control Drawing. Intrinsically safe apparatus, associated apparatus, and other equipment shall be installed in accordance with the control drawing(s).

Exception: A simple apparatus that does not interconnect intrinsically safe circuits.

Informational Note No. 1: The control drawing identification is marked on the apparatus.

Informational Note No. 2: Associated apparatus with a marked U_m of less than 250 V may require additional overvoltage protection at the inputs to limit any possible fault voltages to less than the U_m marked on the product.

Intrinsically safe systems cannot be safely installed unless the proper control drawings are available. Control drawings are required to be supplied by both the manufacturers of associated apparatus and intrinsically safe apparatus. These two control drawings, used together, provide the necessary information for the user to correctly configure and install the intrinsically safe system. If one manufacturer provides both the associated apparatus and the intrinsically safe apparatus as a system, the information for the whole system may be contained on one control drawing.

(B) Location. Intrinsically safe apparatus shall be permitted to be installed in any hazardous (classified) location for which it has been identified.

Associated apparatus shall be permitted to be installed in any hazardous (classified) location for which it has been identified.

Simple apparatus shall be permitted to be installed in any hazardous (classified) location in which the maximum surface temperature of the simple apparatus does not exceed the ignition temperature of the flammable gases or vapors, flammable liquids, combustible dusts, or ignitable fibers/flyings present.

(C) Enclosures. General-purpose enclosures shall be permitted for intrinsically safe apparatus and associated apparatus unless otherwise specified in the manufacturer's documentation.

(D) Simple Apparatus. For simple apparatus, the maximum surface temperature can be determined from the values of the output power from the associated apparatus or apparatus to which it is connected to obtain the temperature class. The temperature class can be determined by:

(1) Reference to Table 504.10(D)

(2) Calculation using the following equation:

$$T = P_o R_{th} + T_{amb}$$

where:

T = surface temperature

P_o = output power marked on the associated apparatus or intrinsically safe apparatus

R_{th} = thermal resistance of the simple apparatus

T_{amb} = ambient temperature (normally 40°C) and reference Table 500.8(C)

In addition, components with a surface area smaller than 10 cm² (excluding lead wires) may be classified as T5 if their surface temperature does not exceed 150°C.

Table 504.10(D) Assessment for T4 Classification According to Component Size and Temperature

Total Surface Area Excluding Lead Wires	Requirement for T4 Classification
<20 mm ²	Surface Temperature ≤275°C
≥20 mm ² ≤10 cm ²	Surface Temperature ≤200°C
≥20 mm ²	Power not exceeding 1.3 W*

*Based on 40°C ambient temperature. Reduce to 1.2 W with an ambient of 60°C or 1.0 W with 80°C ambient temperature.

To avoid causing a thermal ignition hazard using simple apparatus, this clause gives a method to calculate the temperature likely to be generated, using information available on the control drawing provided for the associated apparatus. Higher temperatures are allowed for very small surfaces, since testing has proven that it takes higher temperatures from devices with very small surface areas to thermally ignite flammable atmospheres.

The thermal resistance of a device is a parameter that tells you how much something will heat up as a function of how much power is applied to it, and the units need to be in °C/ Watt to work with Table 504.10(B).

The requirements to consider the temperature of simple apparatus, as well as the calculations for simple apparatus temperature determination, is included in 504.10(B). Table 504.10(B) was also added to permit temperature allowances for small components. Allowing any component to heat up to a level over the autoignition temperature of the flammable gas present may not seem the right thing to do, but testing has determined that a higher temperature is necessary to ignite a flammable atmosphere when a hot surface also has a very small surface area.

504.20 Wiring Methods. Any of the wiring methods suitable for unclassified locations, including those covered by Chapter 7 and Chapter 8, shall be permitted for installing intrinsically safe apparatus. Sealing shall be as provided in 504.70, and separation shall be as provided in 504.30.

Since intrinsically safe wiring does not carry enough energy to ignite

INTERPRETATION OF ARTICLE 504: INTRINSICALLY SAFE SYSTEMS

the flammable atmospheres that it is listed for, any wiring method allowed by the *NEC*[®] can be used in Division 1 and Division 2 to connect associated apparatus and intrinsically safe apparatus. To avoid accidental connection to other nonintrinsically safe circuits or picking up induced currents from other higher power wiring, there are wiring separation requirements imposed by Section 504.30.

504.30 Separation of Intrinsically Safe Conductors.

(A) From Nonintrinsically Safe Circuit Conductors.

(1) In Raceways, Cable Trays, and Cables. Conductors of intrinsically safe circuits shall not be placed in any raceway, cable tray, or cable with conductors of any nonintrinsically safe circuit.

Exception No. 1: Where conductors of intrinsically safe circuits are separated from conductors of nonintrinsically safe circuits by a distance of at least 50 mm (2 in.) and secured, or by a grounded metal partition or an approved insulating partition.

Informational Note: No. 20 gauge sheet metal partitions 0.91 mm (0.0359 in.) or thicker are generally considered acceptable.

Exception No. 2: Where either (1) all of the intrinsically safe circuit conductors or (2) all of the nonintrinsically safe circuit conductors are in grounded metal-sheathed or metal-clad cables where the sheathing or cladding is capable of carrying fault current to ground.

Informational Note: Cables meeting the requirements of Articles 330 and 332 are typical of those considered acceptable.

Exception No. 3: Intrinsically safe circuits in a Division 2 or Zone 2 location shall be permitted to be installed in a raceway, cable tray, or cable along with nonincendive field wiring circuits when installed in accordance with 504.30(B).

Exception No. 4: Intrinsically safe circuits passing through a Division 2 or Zone 2 location to supply apparatus that is located in a Division 1, Zone 0 or Zone 1 location shall be permitted to be installed in a raceway, cable tray, or cable along with nonincendive field wiring circuits when installed in accordance with 504.30(B).

Informational Note: Nonincendive field wiring circuits are described in 501.10(B)(3), 502.10(B)(3), and 503.10(A)(4).

(2) Within Enclosures. Conductors of intrinsically safe circuits shall be secured so that any conductor that might come loose from a terminal is unlikely to come into contact with another terminal. The conductors shall be separated from conductors of nonintrinsically safe circuits by one of the methods in (1) through (4).

(1) Separation by at least 50 mm (2 in.) from conductors of any nonintrinsically safe circuits

(2) Separation from conductors of nonintrinsically safe circuits by use of a grounded metal partition 0.91 mm (0.0359 in.) or thicker

(3) Separation from conductors of nonintrinsically safe circuits by use of an approved insulating partition that extends to within 1.5 mm (0.0625 in.) of the enclosure walls

(4) Where either (1) all of the intrinsically safe circuit conductors or (2) all of the nonintrinsically safe circuit conductors are in grounded metal-sheathed or metal-clad cables where the sheathing or cladding is capable of carrying fault current to ground

Informational Note No. 1: Cables meeting the requirements of Articles 330 and 332 are typical of those considered acceptable.

Informational Note No. 2: The use of separate wiring compartments for the intrinsically safe and nonintrinsically safe terminals is a typical method of complying with this requirement.

Informational Note No. 3: Physical barriers such as grounded metal partitions or approved insulating partitions or approved restricted access wiring ducts separated from other such ducts by at least 19 mm (3/4 in.) can be used to help ensure the required separation of the wiring.

(3) Other (Not in Raceway or Cable Tray Systems). Conductors and cables of intrinsically safe circuits run in other than raceway or cable tray systems shall be separated by at least 50 mm (2 in.) and secured from conductors and cables of any nonintrinsically safe circuits.

Exception: Where either (1) all of the intrinsically safe circuit conductors are in Type MI or MC cables or (2) all of the nonintrinsically safe circuit conductors are in raceways or Type MI or MC cables where the sheathing or cladding is capable of carrying fault current to ground.

(B) From Different Intrinsically Safe Circuit Conductors. The clearance between two terminals for connection of field wiring of different intrinsically safe circuits shall be at least 6 mm (0.25 in.), unless this clearance is permitted to be reduced by the control drawing. Different intrinsically safe circuits shall be separated from each other by one of the following means:

(1) The conductors of each circuit are within a grounded metal shield.

(2) The conductors of each circuit have insulation with a minimum thickness of 0.25 mm (0.01 in.).

Exception: Unless otherwise identified.

(C) From Grounded Metal. The clearance between the uninsulated parts of field wiring conductors connected to terminals and grounded metal or other conducting parts shall be at least 3 mm (0.125 in.).

Separation of intrinsically safe circuits, both terminations and conductors, from all other circuits, including other intrinsically safe circuits, must be maintained in order to insure the safety of the system. Separation is accomplished by using separate raceways for intrinsically safe wiring, keeping a certain distance between intrinsically safe circuits and others circuits, or in some cases, by making sure the conductors are separated by a minimum thickness of solid insulation.

Section 504.30(B)(3) provides a default field wiring terminal clearance requirement of 6mm for intrinsically safe circuits, unless the control drawing permits a smaller clearance.

504.50 Grounding.

(A) Intrinsically Safe Apparatus, Enclosures, and Raceways. Intrinsically safe apparatus, enclosures, and raceways, if of metal, shall be connected to the equipment grounding conductor.

Informational Note: In addition to an equipment grounding conductor connection, a connection to a grounding electrode may be needed for some associated apparatus; for example, zener diode barriers, if specified in the control drawing. See ANSI/ISA-RP 12.06.01-2003, *Recommended Practice for Wiring Methods for Hazardous (Classified) Locations Instrumentation — Part 1: Intrinsic Safety*.

Some associated apparatus, such as non-isolating type zener

INTERPRETATION OF ARTICLE 504: INTRINSICALLY SAFE SYSTEMS

diode barriers, need an effective ground connection (less than 1 ohm to ground) to operate correctly and maintain the safety of the intrinsically safe circuit. The safety ground for zener barriers must be connected separately to ground from all other grounds, to insure that any other electrical equipment in the area where the barriers are installed does not inadvertently use the barrier ground in the case of a ground fault occurring on the other equipment. The zener diode safety barrier ground is sized to handle a very small fault current, and a large fault current from a different piece of electrical equipment could overload the safety ground and cause it to separate. This is not a concern if galvanically isolated barriers are used, since they require no ground connection to operate properly and limit the power to the hazardous location by using an isolation transformer or optical couplers.

(B) Associated Apparatus and Cable Shields. Associated apparatus and cable shields shall be grounded in accordance with the required control drawing. See 504.10(A).

Informational Note: Supplementary connection(s) to the grounding electrode may be needed for some associated apparatus; for example, zener diode barriers, if specified in the control drawing. See ANSI/ISA RP 12.06.01-2003, Recommended Practice for Wiring Methods for Hazardous (Classified) Locations Instrumentation — Part 1: Intrinsic Safety.

(C) Connection to Grounding Electrodes. Where connection to a grounding electrode is required, the grounding electrode shall be as specified in 250.52(A)(1), (A)(2), (A)(3), and (A)(4) and shall comply with 250.30(A)(4). Sections 250.52(A)(5), (A)(7), and (A)(8) shall not be used if any of the electrodes specified in 250.52(A)(1), (A)(2), (A)(3), or (A)(4) are present.

504.60 Bonding.

(A) Hazardous Locations. In hazardous (classified) locations, intrinsically safe apparatus shall be bonded in the hazardous (classified) location in accordance with 250.100.

(B) Unclassified. In unclassified locations, where metal raceways are used for intrinsically safe system wiring in hazardous (classified) locations, associated apparatus shall be bonded in accordance with 501.30(A), 502.30(A),

503.30(A), 505.25, or 506.25 as applicable.

504.70 Sealing. Conduits and cables that are required to be sealed by 501.15, 502.15, 505.16, and 506.16 shall be sealed to minimize the passage of gases, vapors, or dusts. Such seals shall not be required to be explosionproof or flameproof but shall be identified for the purpose of minimizing passage of gases, vapors, or dusts under normal operating conditions and shall be accessible.

Exception: Seals shall not be required for enclosures that contain only intrinsically safe apparatus, except as required by 501.17.

Unlike explosionproof enclosures, where listed explosionproof seals are necessary to keep an explosion generated inside the enclosure from traveling through the raceway, seals on intrinsically safe enclosures do not need to be explosionproof, since intrinsically safe equipment cannot cause an ignition. The seals used do not need to be listed, and only need to provide environmental protection. These seals are required to be identified for the purpose of minimizing the passage of gases, vapors or dusts under normal operating conditions. This rule requires that these seals be accessible. (See Article 100 for the definition of Identified.)

504.80 Identification. Labels required by this section shall be suitable

for the environment where they are installed with consideration given to exposure to chemicals and sunlight.

(A) Terminals. Intrinsically safe circuits shall be identified at terminal and junction locations in a manner that is intended to prevent unintentional interference with the circuits during testing and servicing.

(B) Wiring. Raceways, cable trays, and other wiring methods for intrinsically safe system wiring shall be identified with permanently affixed labels with the wording “Intrinsic Safety Wiring” or equivalent. The labels shall be located so as to be visible after installation and placed so that they may be readily traced through the entire length of the installation. Intrinsic safety circuit labels shall appear in every section of the wiring system that is separated by enclosures, walls, partitions, or floors. Spacing between labels shall not be more than 7.5 m (25 ft).

Exception: Circuits run underground shall be permitted to be identified where they become accessible after emergence from the ground.

Informational Note No. 1: Wiring methods permitted in unclassified locations may be used for intrinsically safe systems in hazardous (classified) locations. Without labels to identify the application of the wiring, enforcement authorities cannot determine that an installation is in compliance with this Code.

Informational Note No. 2: In unclassified locations, identification is necessary to ensure that nonintrinsically safe wire will not be inadvertently added to existing raceways at a later date.

(C) Color Coding. Color coding shall be permitted to identify intrinsically safe conductors where they are colored light blue and where no other conductors colored light blue are used. Likewise, color coding shall be permitted to identify raceways, cable trays, and junction boxes where they are colored light blue and contain only intrinsically safe wiring.

Terminals and wiring for intrinsically safe circuits need to be identified to keep them adequately separated from all other wiring. Light blue is designated as a color code for intrinsically safe wiring if color-coding is desired and light blue has not been used as a color code for any other wiring.

The Intrinsically Safe Sections align with the requirements in the listing product standards, such as ANSI/ISA-60079-11 and ANSI/UL 913.

INTERPRETATION OF ARTICLE 505: CLASS I, ZONE 0, 1, AND 2 LOCATIONS

CHANGES TO ARTICLE 505

The following Article 505 sections have been revised during the 2014 *NEC*® Code cycle. These changes are those that are substantive and should be noted. This list does not include those changes that are editorial in nature.

Underlined text indicates a section that has been revised from the previous *NEC*® edition. It is not intended to indicate legislation text detailing the word-for-word revisions to the section. Where minor revisions have been made to a section, these will include underlined text for select words to indicate the minor revision.

- **Section 505.5(A)**
Classifications of Locations.
- **Section 505.6**
Material Groups. Group II
- **Section 505.7(F)**
Special Precaution. Available Short-Circuit Current for Type of Protection “e”
- **Section 505.9(C)(2)(6)**
Equipment. Marking. Zone Equipment. Temperature Classification. Cable Fittings
- **Table 505.9(C)(2)(4)**
Types of Protection Designation. Encapsulation “mc”
- **Section 505.15(B)(1)(g)**
Wiring Methods. Class I, Zone 1. General. Intrinsic Safety Type “ib”
- **Section 505.15(B)(1)(h)**
Wiring Methods. Class I, Zone 1. General. Optical Fiber Cable
- **Section 505.15(B)(1)(i)**
Wiring Methods. Class I, Zone 1. General. Type TC-ER-HL Cable
- **Section 505.15(C)(1)(b)**
Wiring Methods. Class I, Zone 1. Class I, Zone 2. General. Type TC and TC-ER Cable
- **Section 505.15(C)(1)(h)**
Wiring Methods. Class I, Zone 1. Class I, Zone 2. General. Optical Fiber Cable
- **Section 505.15(C)(2)**
Wiring Methods. Class I, Zone 1. Class I, Zone 2. Flexible Connections. Elevator Cable
- **Section 505.16(B)(5)**
Sealing and Drainage. Zone 1. Cables Capable of Transmitting Gases or Vapors. Optical Fiber Cable
- **Section 505.16(B)(6)**
Sealing and Drainage. Zone 1. Cables Incapable of Transmitting Gases or Vapors. Optical Fiber Cable

- **Section 505.16(C)(2)(a)**
Sealing and Drainage. Zone 2. Cable Seals. Optical Fiber Cable
- **Section 505.16(D)(5)**
Sealing and Drainage. Class I, Zones 0, 1, and 2. Conductor or Optical Fiber Fill. Optical Fiber Cable
- **Section 505.17(B)**
Flexible Cords and Connections. Instrumentation Connections for Zone 2
- **Section 505.20(C)**
Equipment Requirements. Zone 2. Electric Motors
- **Section 505.20(D)**
Equipment Requirements. Zone 2. Materials. Marking
- **Section 505.22**
Increased Safety “e” Motors and Generators. Engine Driven Equipment Ignition Sources
- **Section 505.26(4)**
Process Sealing. Secondary Seals

Informational Note: Text that is followed by a reference in brackets has been extracted from NFPA 497-2012, *Recommended Practice for the Classification of Flammable Liquids, Gases, or Vapors and of Hazardous (Classified) Locations for Electrical Installations in Chemical Process Areas*. Only editorial changes were made to the extracted text to make it consistent with this *Code*.

505.1 Scope. This article covers the requirements for the zone classification system as an alternative to the division classification system covered in Article 500 for electrical and electronic equipment and wiring for all voltages in Class I, Zone 0, Zone 1, and Zone 2 hazardous (classified) locations where fire or explosion hazards may exist due to flammable gases, vapors, or liquids.

Informational Note: For the requirements for electrical and electronic equipment and wiring for all voltages in Class I, Division 1 or Division 2; Class II, Division 1 or Division 2; and Class III, Division 1 or Division 2 hazardous (classified) locations where fire or explosion hazards may exist due to flammable gases or vapors, flammable liquids, or combustible dusts or fibers, refer to Articles 500 through 504.

Article 505 deals with the Zone classification system for hazardous locations, which is based on the IEC hazardous location classification system for flammable gas, and introduces IEC based protection techniques. The Zone area classification system for flammable gas consists of three Zones (Zone 0, Zone 1 and Zone 2), as compared to the Division system, which divides hazardous locations into Division 1 and Division 2.

To correlate the two systems, Division 1 would contain both Zone 0 and Zone 1, and Zone 2 and Division 2 are equivalent.

Division 1	Zone 0
	Zone 1
Division 2	Zone 2

INTERPRETATION OF ARTICLE 505: CLASS I, ZONE 0, 1, AND 2 LOCATIONS

Although conductors in raceways can be used to install Zone equipment, equipment standards for Zone hazardous location protection techniques assume that cable, rather than conductors in conduit, is the preferred wiring method for installation in the hazardous location. The only types of cable now allowed by the *NEC*® for use in Zone 1 installations are MI, MC-HL, and ITC-HL. Flexible Cord is permitted with certain restrictions. There are many more types of cable available outside the U.S. for use in IEC Zone installations, but they are not allowed in Zone installations covered by the *NEC*®. The only types of conduit now allowed by the *NEC*® for use in Class I, Zone 1 installations are Threaded Rigid Metal Conduit and Threaded Steel Intermediate Metal Conduit. Types PVC and RTRC Conduits are permitted with certain restrictions. These types of Cables and Conduit are also permitted for installation in Class I, Zone 2 locations. In addition to these, types MC, MV, TC, ITC, ITC-ER, PLTC, and PLTC-ER cables, Flexible Metal Conduit, Liquidtight Flexible Metal Conduit, Liquidtight Flexible Nonmetallic Conduit, and Flexible Cord are also permitted in Class I, Zone 2 locations with certain restrictions.

505.2 Definitions.

Combustible Gas Detection System. A protection technique utilizing stationary gas detectors in industrial establishments.

Electrical and Electronic Equipment. Materials, fittings, devices, appliances, and the like that are part of, or in connection with, an electrical installation.

Informational Note: Portable or transportable equipment having self-contained power supplies, such as batteryoperated equipment, could potentially become an ignition source in hazardous (classified) locations. See ANSI/ISA- 12.12.03-2011, *Standard for Portable Electronic Products Suitable for Use in Class I and II, Division 2, Class I Zone 2 and Class III, Division 1 and 2 Hazardous (Classified) Locations*.

Encapsulation “m.” Type of protection where electrical parts that could ignite an explosive atmosphere by either sparking or heating are enclosed in a compound in such a way that this explosive atmosphere cannot be ignited.

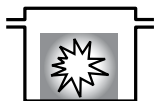

Informational Note No. 1: See ANSI/ISA-60079-18 (12.23.01)-2009, *Explosive atmospheres — Part 18: Equipment protection by encapsulation “m”*; and ANSI/UL 60079-18-2009, *Explosive atmospheres — Part 18: Equipment protection by encapsulation “m.”*

Informational Note No. 2: Encapsulation is designated type of protection “ma” for use in Zone 0 locations. Encapsulation is designated type of protection “m” or “mb” for use in Zone 1 locations. Encapsulation is designated type of protection “mc” for use in Zone 2 locations.

Flameproof “d.” Type of protection where the enclosure will withstand an internal explosion of a flammable mixture that has penetrated into the interior, without suffering damage and without causing ignition, through any joints or structural openings in the enclosure, of an external explosive gas atmosphere consisting of one or more of the gases or vapors for which it is designed.

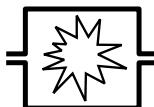

Informational Note: See ANSI/ISA-60079-1 (12.22.01)- 2009, *Explosive Atmospheres*,

Part 1: Equipment protection by flameproof enclosures “d”; and ANSI/UL 60079-1- 2009, *Electrical Apparatus for Explosive Gas Atmospheres — Part 1: Flameproof Enclosures “d.”*

Increased Safety “e.” Type of protection applied to electrical equipment that does not produce arcs or sparks in normal service and under specified abnormal conditions, in which additional measures are applied so as to give increased security against the possibility of excessive temperatures and of the occurrence of arcs and sparks.

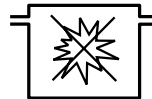

Informational Note: See ANSI/ISA-60079-7 (12.16.01)- 2008, *Explosive Atmospheres, Part 7: Equipment protection by increased safety “e”*; and ANSI/UL 60079-7-2008, *Electrical Apparatus for Explosive Gas Atmospheres — Part 7: Increased Safety “e.”*

Intrinsic Safety “i.” Type of protection where any spark or thermal effect is incapable of causing ignition of a mixture of flammable or combustible material in air under prescribed test conditions.



Informational Note No. 1: See ANSI/UL 913-2006, *Intrinsically Safe Apparatus and Associated Apparatus for Use in Class I, II, and III, Hazardous Locations*; ANSI/ISA- 60079-11 (12.02.01)-2011, *Explosive Atmospheres: Part 11: Equipment protection by intrinsic safety “i”*; and ANSI/UL 60079-11-2011, *Explosive Atmospheres, Part 11: Equipment protection by intrinsic safety “i.”*

Informational Note No. 2: Intrinsic safety is designated type of protection “ia” for use in Zone 0 locations. Intrinsic safety is designated type of protection “ib” for use in Zone 1 locations. Intrinsic safety is designated type of protection “ic” for use in Zone 2 locations.

Informational Note No. 3: Intrinsically safe associated apparatus, designated by [ia], [ib], or [ic], is connected to intrinsically safe apparatus (“ia,” “ib,” or “ic,” respectively) but is located outside the hazardous (classified) location unless also protected by another type of protection (such as flameproof).

Oil Immersion “o.” Type of protection where electrical equipment is immersed in a protective liquid in such a way that an explosive atmosphere that may be above the liquid or outside the enclosure cannot be ignited.



Informational Note: See ANSI/ISA-60079-6 (12.00.05)- 2009, *Explosive Atmospheres, Part 6: Equipment protection by oil immersion “o”*; and ANSI/UL 60079-6-2009, *Electrical Apparatus for Explosive Gas Atmospheres — Part 6: Oil-Immersion “o.”*

Powder Filling “q.” Type of protection where electrical parts capable of igniting an explosive atmosphere are fixed in position and completely surrounded by filling material (glass or quartz powder) to prevent the ignition of an external explosive atmosphere.

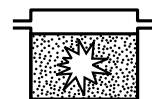

Informational Note: See ANSI/ISA-60079-5 (12.00.04)- 2009, *Explosive Atmospheres, Part 5: Equipment protection by powder filling “q”*; and ANSI/UL 60079-5, *Electrical Apparatus*

INTERPRETATION OF ARTICLE 505: CLASS I, ZONE 0, 1, AND 2 LOCATIONS

for Explosive Gas Atmospheres — Part 5: Powder Filling “q.”

Pressurization “p.” Type of protection for electrical equipment that uses the technique of guarding against the ingress of the external atmosphere, which may be explosive, into an enclosure by maintaining a protective gas therein at a pressure above that of the external atmosphere.



Informational Note: See ANSI/ISA-60079-2 (12.04.01)- 2010, *Explosive Atmospheres, Part 2: Equipment protection by pressurized enclosures “p”*; and IEC 60079-13- 2010, *Electrical apparatus for explosive gas atmospheres — Part 13: Construction and use of rooms or buildings protected by pressurization*.

Type of Protection “n.” Type of protection where electrical equipment, in normal operation, is not capable of igniting a surrounding explosive gas atmosphere and a fault capable of causing ignition is not likely to occur.

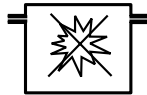

Informational Note: See ANSI/UL 60079-15-2009, *Electrical Apparatus for Explosive Gas Atmospheres — Part 15: Type of Protection “n”*; and ANSI/ISA-60079-15 (12.12.02)-2009, *Explosive Atmospheres — Part 15: Equipment protection by type of protection “n.”*

Unclassified Locations. Locations determined to be neither Class I, Division 1; Class I, Division 2; Class I, Zone 0; Class I, Zone 1; Class I, Zone 2; Class II, Division 1; Class II, Division 2; Class III, Division 1; Class III, Division 2; Zone 20; Zone 21; Zone 22; or any combination thereof.

505.3 Other Articles. All other applicable rules contained in this Code shall apply to electrical equipment and wiring installed in hazardous (classified) locations.

Exception: As modified by Article 504 and this article.

505.4 General.

(A) Documentation for Industrial Occupancies. All areas in industrial occupancies designated as hazardous (classified) locations shall be properly documented. This documentation shall be available to those authorized to design, install, inspect, maintain, or operate electrical equipment at the location.

Informational Note: For examples of area classification drawings, see ANSI/API RP 505-1997, *Recommended Practice for Classification of Locations for Electrical Installations at Petroleum Facilities Classified as Class I, Zone 0, Zone 1, or Zone 2*; ANSI/ISA-TR(12.24.01)-1998 (IEC 60079-10 Mod), *Recommended Practice for Classification of Locations for Electrical Installations Classified as Class I, Zone 0, Zone 1, or Zone 2*; IEC 60079-10-1995, *Electrical Apparatus for Explosive Gas Atmospheres, Classification of Hazardous Areas*; and *Model Code of Safe Practice in the Petroleum Industry, Part 15: Area Classification Code for Petroleum Installations*, IP 15, The Institute of Petroleum, London.

(B) Reference Standards. Important information relating to topics covered in Chapter 5 may be found in other publications.

Informational Note No. 1: It is important that the authority having jurisdiction be familiar with recorded industrial experience as well as with standards of the National Fire Protection Association (NFPA), the American Petroleum Institute (API), the International Society of Automation (ISA), and the International Electrotechnical Commission (IEC) that may be of use in the classification of various locations, the determination of adequate

ventilation, and the protection against static electricity and lightning hazards.

Informational Note No. 2: For further information on the classification of locations, see NFPA 497-2012, *Recommended Practice for the Classification of Flammable Liquids, Gases, or Vapors and of Hazardous (Classified) Locations for Electrical Installations in Chemical Process Areas*; ANSI/API RP 505-1997, *Recommended Practice for Classification of Locations for Electrical Installations at Petroleum Facilities Classified as Class I, Zone 0, Zone 1, or Zone 2*; ANSI/ISA-TR(12.24.01)-1998 (IEC 60079-10- Mod), *Recommended Practice for Classification of Locations for Electrical Installations Classified as Class I, Zone 0, Zone 1, or Zone 2*; IEC 60079-10-1995, *Electrical Apparatus for Explosive Gas Atmospheres, Classification of Hazardous Areas*; and *Model Code of Safe Practice in the Petroleum Industry, Part 15: Area Classification Code for Petroleum Installations*, IP 15, The Institute of Petroleum, London.

Informational Note No. 3: For further information on protection against static electricity and lightning hazards in hazardous (classified) locations, see NFPA 77-2014, *Recommended Practice on Static Electricity*; NFPA 780-2014, *Standard for the Installation of Lightning Protection Systems*; and API RP 2003-1998, *Protection Against Ignitions Arising Out of Static Lightning and Stray Currents*.

Informational Note No. 4: For further information on ventilation, see NFPA 30-2012, *Flammable and Combustible Liquids Code*, and ANSI/API RP 505-1997, *Recommended Practice for Classification of Locations for Electrical Installations at Petroleum Facilities Classified as Class I, Zone 0, Zone 1, or Zone 2*.

Informational Note No. 5: For further information on electrical systems for hazardous (classified) locations on offshore oil and gas producing platforms, see ANSI/API RP 14FZ-2000, *Recommended Practice for Design and Installation of Electrical Systems for Fixed and Floating Offshore Petroleum Facilities for Unclassified and Class I, Zone 0, Zone 1, and Zone 2 Locations*.

Informational Note No. 6: For further information on the installation of electrical equipment in hazardous (classified) locations in general, see IEC 60079-14-1996, *Electrical apparatus for explosive gas atmospheres — Part 14: Electrical installations in explosive gas atmospheres (other than mines)*, and IEC 60079-16-1990, *Electrical apparatus for explosive gas atmospheres — Part 16: Artificial ventilation for the protection of analyzer(s) houses*.

Informational Note No. 7: For further information on application of electrical equipment in hazardous (classified) locations in general, see ANSI/ISA-60079-0 (12.00.01)- 2009, *Explosive Atmospheres — Part 0: Equipment — General Requirements*; ANSI/ISA-12.01.01-1999, *Definitions and Information Pertaining to Electrical Apparatus in Hazardous (Classified) Locations*; and ANSI/UL 60079-0, *Electrical Apparatus for Explosive Gas Atmospheres — Part 0: General Requirements*

505.5 Classifications of Locations.

(A) Classification of Locations. Locations shall be classified depending on the properties of the flammable gases, flammable liquid-produced vapors, combustible liquid-produced vapors, combustible dusts, or fibers/flyings that may be present and the likelihood that a flammable or combustible concentration or quantity is present. Each room, section, or area shall be considered individually in determining its classification. Where pyrophoric materials are the only materials used or handled, these locations are outside the scope of this article.

NFPA 497 and NFPA 499 do not address the requirements for the use of pyrophoric materials.

Informational Note No. 1: See 505.7 for restrictions on area classification.

Informational Note No. 2: Through the exercise of ingenuity in the layout of electrical installations for hazardous (classified) locations, it is frequently possible to locate much of the equipment in reduced level of classification or in an unclassified location and, thus, to reduce the amount of special equipment required.

Rooms and areas containing ammonia refrigeration systems that are equipped with adequate mechanical ventilation

INTERPRETATION OF ARTICLE 505: CLASS I, ZONE 0, 1, AND 2 LOCATIONS

may be classified as “unclassified” locations.

Informational Note: For further information regarding classification and ventilation of areas involving ammonia, see ANSI/ASHRAE 15-1994, *Safety Code for Mechanical Refrigeration*; and ANSI/CGA G2.1-1989 (14-39), *Safety Requirements for the Storage and Handling of Anhydrous Ammonia*.

(B) Class I, Zone 0, 1, and 2 Locations. Class I, Zone 0, 1, and 2 locations are those in which flammable gases or vapors are or may be present in the air in quantities sufficient to produce explosive or ignitable mixtures. Class I, Zone 0, 1, and 2 locations shall include those specified in 505(B)(1), (B)(2), and (B)(3).

(1) Class I, Zone 0. A Class I, Zone 0 location is a location in which

(1) Ignitable concentrations of flammable gases or vapors are present continuously, or

(2) Ignitable concentrations of flammable gases or vapors are present for long periods of time.

Informational Note No. 1: As a guide in determining when flammable gases or vapors are present continuously or for long periods of time, refer to ANSI/API RP 505-1997, *Recommended Practice for Classification of Locations for Electrical Installations of Petroleum Facilities Classified as Class I, Zone 0, Zone 1 or Zone 2*; ANSI/ISA-TR12.24.01- 1998 (IEC 60079-10 Mod), *Recommended Practice for Classification of Locations for Electrical Installations Classified as Class I, Zone 0, Zone 1, or Zone 2*; IEC 60079- 10-1995, *Electrical apparatus for explosive gas atmospheres, classifications of hazardous areas; and Area Classification Code for Petroleum Installations, Model Code, Part 15*, Institute of Petroleum.

Informational Note No. 2: This classification includes locations inside vented tanks or vessels that contain volatile flammable liquids; inside inadequately vented spraying or coating enclosures, where volatile flammable solvents are used; between the inner and outer roof sections of a floating roof tank containing volatile flammable liquids; inside open vessels, tanks and pits containing volatile flammable liquids; the interior of an exhaust duct that is used to vent ignitable concentrations of gases or vapors; and inside inadequately ventilated enclosures that contain normally venting instruments utilizing or analyzing flammable fluids and venting to the inside of the enclosures.

(2) Class I, Zone 1. A Class I, Zone 1 location is a location

(1) In which ignitable concentrations of flammable gases or vapors are likely to exist under normal operating conditions; or

(2) In which ignitable concentrations of flammable gases or vapors may exist frequently because of repair or maintenance operations or because of leakage; or

(3) In which equipment is operated or processes are carried on, of such a nature that equipment breakdown or faulty operations could result in the release of ignitable concentrations of flammable gases or vapors and also cause simultaneous failure of electrical equipment in a mode to cause the electrical equipment to become a source of ignition; or

(4) That is adjacent to a Class I, Zone 0 location from which ignitable concentrations of vapors could be communicated, unless communication is prevented by adequate positive pressure ventilation from a source of clean air and effective safeguards against ventilation failure are provided.

Informational Note No. 1: Normal operation is considered the situation when plant equipment is operating within its design parameters. Minor releases of flammable material may be part of normal operations. Minor releases include the releases from mechanical packings on pumps. Failures that involve repair or shutdown (such as the breakdown of pump seals and flange gaskets, and spillage caused by accidents) are not considered normal operation.

Informational Note No. 2: This classification usually includes locations where volatile flammable liquids or liquefied flammable gases are transferred from one container to another. In areas in the vicinity of spraying and painting operations where flammable solvents are used; adequately ventilated drying rooms or compartments for evaporation of flammable solvents; adequately ventilated locations containing fat and oil extraction equipment using volatile flammable solvents; portions of cleaning and dyeing plants where volatile flammable liquids are used; adequately ventilated gas generator rooms and other portions of gas manufacturing plants where flammable gas may escape; inadequately ventilated pump rooms for flammable gas or for volatile flammable liquids; the interiors of refrigerators and freezers in which volatile flammable materials are stored in the open, lightly stoppered, or in easily ruptured containers; and other locations where ignitable concentrations of flammable vapors or gases are likely to occur in the course of normal operation but not classified Zone 0.

(3) Class I, Zone 2. A Class I, Zone 2 location is a location

(1) In which ignitable concentrations of flammable gases or vapors are not likely to occur in normal operation and, if they do occur, will exist only for a short period; or

(2) In which volatile flammable liquids, flammable gases, or flammable vapors are handled, processed, or used but in which the liquids, gases, or vapors normally are confined within closed containers of closed systems from which they can escape, only as a result of accidental rupture or breakdown of the containers or system, or as a result of the abnormal operation of the equipment with which the liquids or gases are handled, processed, or used; or

(3) In which ignitable concentrations of flammable gases or vapors normally are prevented by positive mechanical ventilation but which may become hazardous as a result of failure or abnormal operation of the ventilation equipment; or

(4) That is adjacent to a Class I, Zone 1 location, from which ignitable concentrations of flammable gases or vapors could be communicated, unless such communication is prevented by adequate positive-pressure ventilation from a source of clean air and effective safeguards against ventilation failure are provided.

Informational Note: The Zone 2 classification usually includes locations where volatile flammable liquids or flammable gases or vapors are used but which would become hazardous only in case of an accident or of some unusual operating condition.

505.6 Material Groups. For purposes of testing, approval, and area classification, various air mixtures (not oxygen enriched) shall be grouped as required in 505.6(A), (B), and (C).

Informational Note No. 1: Group I is intended for use in describing atmospheres that contain firedamp (a mixture of gases, composed mostly of methane, found underground, usually in mines). This *Code* does not apply to installations underground in mines. See 90.2(B).

Informational Note No. 2: The gas and vapor subdivision as described above is based on the maximum experimental safe gap (MESG), minimum igniting current (MIC), or both. Test equipment for determining the MESG is described in IEC 60079-1A-1975, Amendment No. 1 (1993), *Construction and verification tests of flameproof enclosures of electrical apparatus*; and UL Technical Report No. 58 (1993). The test equipment for determining MIC is described in IEC 60079-11- 1999, *Electrical apparatus for explosive gas atmospheres — Part 11: Intrinsic safety “i.”* The classification of gases or vapors according to their maximum experimental safe gaps and minimum igniting currents is described in IEC 60079-12- 1978, *Classification of mixtures of gases or vapours with air according to their maximum experimental safe gaps and minimum igniting currents*.

Informational Note No. 3: Group II is currently subdivided into Group IIA, Group IIB, and Group IIC. Prior marking requirements permitted some types of protection to be marked without a subdivision, showing only Group II.

INTERPRETATION OF ARTICLE 505: CLASS I, ZONE 0, 1, AND 2 LOCATIONS

Informational Note No. 4: It is necessary that the meanings of the different equipment markings and Group II classifications be carefully observed to avoid confusion with Class I, Divisions 1 and 2, Groups A, B, C, and D.

Class I, Zone 0, 1, and 2, groups shall be as follows:

(A) Group IIC. Atmospheres containing acetylene, hydrogen, or flammable gas, flammable liquid–produced vapor, or combustible liquid–produced vapor mixed with air that may burn or explode, having either a maximum experimental safe gap (MESG) value less than or equal to 0.50 mm or minimum igniting current ratio (MIC ratio) less than or equal to 0.45. [497:3.3.5.2.1]

Informational Note: Group IIC is equivalent to a combination of Class I, Group A, and Class I, Group B, as described in 500.6(A)(1) and (A)(2).

(B) Group IIB. Atmospheres containing acetaldehyde, ethylene, or flammable gas, flammable liquid–produced vapor, or combustible liquid–produced vapor mixed with air that may burn or explode, having either maximum experimental safe gap (MESG) values greater than 0.50 mm and less than or equal to 0.90 mm or minimum igniting current ratio (MIC ratio) greater than 0.45 and less than or equal to 0.80. [497:3.3.5.2.2]

Informational Note: Group IIB is equivalent to Class I, Group C, as described in 500.6(A)(3).

(C) Group IIA. Atmospheres containing acetone, ammonia, ethyl alcohol, gasoline, methane, propane, or flammable gas, flammable liquid–produced vapor, or combustible liquid–produced vapor mixed with air that may burn or explode, having either a maximum experimental safe gap (MESG) value greater than 0.90 mm or minimum igniting current ratio (MIC ratio) greater than 0.80. [497:3.3.5.2.3]

Informational Note: Group IIA is equivalent to Class I, Group D as described in 500.6(A)(4).

As in the Class/Division system the grouping of flammable gases in the Zone system is also done by ranking them by ignition energy and MESG. Group I gases are those found in underground mines, and are not covered by the scope of the *NEC*. Group II gases are those not in mining situations, and are divided into three groups: Group IIC, Group IIB and Group IIA, from lowest ignition energy to highest. The correlation of the Zone gas groups to the division gas Groups is shown in the following table.

Comparison of Material Group Classification

Typical Material	Article 500 Division Group	Article 505 Zone Group
Acetylene	A	IIC
Hydrogen	B	IIC *
Ethylene	C	IIB
Gasoline-Propane-Methane	D	IIA

* Products rated and marked for IIB + H₂ are suitable for use in hydrogen atmospheres.

505.7 Special Precaution. Article 505 requires equipment construction and installation that ensures safe performance under conditions of proper use and maintenance.

Informational Note No. 1: It is important that inspection authorities and users exercise more than ordinary care with regard to the installation and maintenance of electrical equipment in hazardous (classified) locations.

Informational Note No. 2: Low ambient conditions require special consideration. Electrical equipment depending on the protection techniques described by 505.8(A) may not be suitable for use at temperatures lower than –20°C (–4°F) unless they are identified for use at lower temperatures. However, at low ambient temperatures, flammable concentrations of vapors may not exist in a location classified Class I, Zones 0, 1, or 2 at normal ambient temperature.

(A) Implementation of Zone Classification System. Classification of areas, engineering and design, selection of equipment and wiring methods, installation, and inspection shall be performed by qualified persons.

The Section requires that the total process of implementation of the Zone Classification System be conducted by qualified persons. (See Article 100 for the definition of qualified persons). The older rule requiring that the classification of areas and the selection of equipment and wiring methods be the sole authority of a registered professional engineer had been removed.

(B) Dual Classification. In instances of areas within the same facility classified separately, Class I, Zone 2 locations shall be permitted to abut, but not overlap, Class I, Division 2 locations. Class I, Zone 0 or Zone 1 locations shall not abut Class I, Division 1 or Division 2 locations.

(C) Reclassification Permitted. A Class I, Division 1 or Division 2 location shall be permitted to be reclassified as a Class I, Zone 0, Zone 1, or Zone 2 location, provided all of the space that is classified because of a single flammable gas or vapor source is reclassified under the requirements of this article.

(D) Solid Obstacles. Flameproof equipment with flanged joints shall not be installed such that the flange openings are closer than the distances shown in Table 505.7(D) to any solid obstacle that is not a part of the equipment (such as steelworks, walls, weather guards, mounting brackets, pipes, or other electrical equipment) unless the equipment is listed for a smaller distance of separation.

Section 505.7(D) is necessary as testing of enclosures with flanged joints showed that smaller clearances than those currently in the type “d” equipment standards are necessary to stop ignition transmission of a hydrogen flammable atmosphere, if the outside edge of the flange is too close to a solid object. Precautions need to be taken so that type “d” enclosures with flanged joints are not installed with a solid object too close to the outside of the flange, unless that enclosure has been tested with a solid obstruction in front of the flange and rated for that condition.

Table 505.7(D) Minimum Distance of Obstructions from Flameproof “d” Flange Openings

Gas Group	Minimum Distance	
	mm	in.
IIC	40	1 ³⁷ / ₆₄
IIB	30	1 ³ / ₁₆
IIA	10	2 ⁵ / ₆₄

(E) Simultaneous Presence of Flammable Gases and Combustible Dusts or Fibers/Flyings. Where flammable gases, combustible dusts, or fibers/flyings are or may be present at the same time, the simultaneous presence shall be considered during the selection and installation of the electrical equipment and the wiring methods, including the determination of the safe operating temperature of the electrical equipment.

INTERPRETATION OF ARTICLE 505: CLASS I, ZONE 0, 1, AND 2 LOCATIONS

This Section addresses the issue of simultaneous presence since Article 506 had addressed this issue. This Section correlates with the requirements of Article 506.

(F) Available Short-Circuit Current for Type of Protection “e”. The available short-circuit current for electrical equipment using type of protection “e” for the field wiring connections in Zone 1 locations shall be limited to 10,000 rms symmetrical amperes to reduce the likelihood of ignition of a flammable atmosphere by an arc during a short-circuit event.

Informational Note: Limitation of the available shortcircuit current to this level may require the application of current-limiting fuses or current-limiting circuit breakers.

This Section and Informational Note is necessary as ANSI/UL 508A limits the short circuit current rating of terminals and terminal blocks to 10,000 rms Amps unless otherwise specified. These terminals are also employed in applications other than those covered by ANSI/UL 508A.

505.8 Protection Techniques. Acceptable protection techniques for electrical and electronic equipment in hazardous (classified) locations shall be as described in 505.8(A) through (I).

Informational Note: For additional information, see ANSI/ISA-60079-0 (12.00.01)-2009, *Explosive Atmospheres — Part 0: Equipment — General Requirements*; ANSI/ISA-12.01.01-1999, *Definitions and Information Pertaining to Electrical Apparatus in Hazardous (Classified) Locations*; and ANSI/UL 60079-0, *Electrical Apparatus for Explosive Gas Atmospheres — Part 0: General Requirements*.

(A) Flameproof “d”. This protection technique shall be permitted for equipment in Class I, Zone 1 or Zone 2 locations.

(B) Purged and Pressurized. This protection technique shall be permitted for equipment in those Class I, Zone 1 or Zone 2 locations for which it is identified.

(C) Intrinsic Safety. This protection technique shall be permitted for apparatus and associated apparatus in Class I, Zone 0, Zone 1, or Zone 2 locations for which it is listed.

(D) Type of Protection “n”. This protection technique shall be permitted for equipment in Class I, Zone 2 locations. Type of protection “n” is further subdivided into nA, nC, and nR.

Informational Note: See Table 505.9(C)(2)(4) for the descriptions of subdivisions for type of protection “n”.

(E) Oil Immersion “o”. This protection technique shall be permitted for equipment in Class I, Zone 1 or Zone 2 locations.

(F) Increased Safety “e”. This protection technique shall be permitted for equipment in Class I, Zone 1 or Zone 2 locations.

(G) Encapsulation “m”. This protection technique shall be permitted for equipment in Class I, Zone 0, Zone 1, or Zone 2 locations for which it is identified.

Informational Note: See Table 505.9(C)(2)(4) for the descriptions of subdivisions for encapsulation.

(H) Powder Filling “q”. This protection technique shall be permitted for equipment in Class I, Zone 1 or Zone 2 locations.

(I) Combustible Gas Detection System. A combustible gas detection system shall be permitted as a means of protection in industrial

establishments with restricted public access and where the conditions of maintenance and supervision ensure that only qualified persons service the installation. Where such a system is installed, equipment specified in 505.8(I)(1), (I)(2), or (I)(3) shall be permitted. The type of detection equipment, its listing, installation location(s), alarm and shutdown criteria, and calibration frequency shall be documented when combustible gas detectors are used as a protection technique.

Informational Note No. 1: For further information, see ANSI/API RP 505-1997, *Recommended Practice for Classification of Locations for Electrical Installations at Petroleum Facilities Classified as Class I, Zone 0, Zone 1, and Zone 2*.

Informational Note No. 2: For further information, see ANSI/ISA-60079-29-2, *Explosive Atmospheres — Part 29-2: Gas detectors — Selection, installation, use and maintenance of detectors for flammable gases and oxygen*.

Informational Note No. 3: For further information, see ANSI/ISA-TR12.13.03-2009, *Guide for Combustible Gas Detection as a Method of Protection*.

(1) Inadequate Ventilation. In a Class I, Zone 1 location that is so classified due to inadequate ventilation, electrical equipment suitable for Class I, Zone 2 locations shall be permitted. Combustible gas detection equipment shall be listed for Class I, Zone 1, for the appropriate material group, and for the detection of the specific gas or vapor to be encountered.

(2) Interior of a Building. In a building located in, or with an opening into, a Class I, Zone 2 location where the interior does not contain a source of flammable gas or vapor, electrical equipment for unclassified locations shall be permitted. Combustible gas detection equipment shall be listed for Class I, Zone 1 or Class I, Zone 2, for the appropriate material group, and for the detection of the specific gas or vapor to be encountered.

(3) Interior of a Control Panel. In the interior of a control panel containing instrumentation utilizing or measuring flammable liquids, gases, or vapors, electrical equipment suitable for Class I, Zone 2 locations shall be permitted. Combustible gas detection equipment shall be listed for Class I, Zone 1, for the appropriate material group, and for the detection of the specific gas or vapor to be encountered.

Since Division 1 contains Zone 0, which is the most dangerous of the hazardous locations, equipment used in Division 1 has to be built to handle the worst-case conditions. In a Division 1 location, the only protection techniques available are explosionproof enclosures, purging or pressurizing, and intrinsic safety for very low power applications.

By splitting Division 1 into two parts, Zone 0 and Zone 1, the Zone system allows the use of some additional protection techniques such as increased safety, encapsulation, and powder filling, that are not possible for Division 1 equipment. Intrinsic safety and encapsulation “ma” are the only protection techniques allowed in Zone 0.

In Section 505.8(I), a documentation requirement for listing information, the types of detectors used, installation locations, alarm and shutdown criteria and calibration frequency is included in the Combustible Gas Detection System protection technique.

Informational Note No. 1 in Section 505.8(I) references ANSI/API RP 505 instead of ANSI/API RP 500. API RP 505 covers area classifications for the Zone system in petroleum facilities, and API RP 500 covers classifications for the Division system.

Section 505.8(I) requires that combustible gas detection equipment be listed for the appropriate gas group and for the specific gas or vapor encountered.

INTERPRETATION OF ARTICLE 505: CLASS I, ZONE 0, 1, AND 2 LOCATIONS

505.9 Equipment.

(A) Suitability. Suitability of identified equipment shall be determined by one of the following:

- (1) Equipment listing or labeling
- (2) Evidence of equipment evaluation from a qualified testing laboratory or inspection agency concerned with product evaluation
- (3) Evidence acceptable to the authority having jurisdiction such as a manufacturer's self-evaluation or an owner's engineering judgment

Informational Note: Additional documentation for equipment may include certificates demonstrating compliance with applicable equipment standards, indicating special conditions of use, and other pertinent information.

(B) Listing.

(1) Equipment that is listed for a Zone 0 location shall be permitted in a Zone 1 or Zone 2 location of the same gas or vapor, provided that it is installed in accordance with the requirements for the marked type of protection. Equipment that is listed for a Zone 1 location shall be permitted in a Zone 2 location of the same gas or vapor, provided that it is installed in accordance with the requirements for the marked type of protection.

(2) Equipment shall be permitted to be listed for a specific gas or vapor, specific mixtures of gases or vapors, or any specific combination of gases or vapors.

Informational Note: One common example is equipment marked for "IIB. + H₂."

IMPORTANT: Equipment intended to be installed in *NEC*[®] Zone hazardous locations needs to be evaluated to determine its suitability. Equipment that is certified to standards other than those adapted to meet U.S. requirements, may not be suitable for use when installed using *NEC*[®] installation techniques, and the electrical portions of the equipment may not even meet the minimum U.S. requirements for use in unclassified locations.

For example, type "d" enclosures evaluated to the IEC standards assume that cables will be used to connect them to the wiring system, and will be sealed by a cable gland within 50 mm (2 in.) of the enclosure. If the enclosure is connected using conduit, with a seal within 18 inches to *NEC*[®] rules, the internal explosion pressure could be higher. The IEC test gas mixtures used for the explosion transmission testing are also different from those specified in the standards for Division explosionproof equipment. These factors taken together could cause a type "d" enclosure to fail when installed with conduit according to the *NEC*[®] rules.

The Informational Note for this section notes the gas group rating IIB+H₂ is often used. This is because IIB+H₂ in the Zone system corresponds to the Division system Gas Group B.

Section 505.9(B)(1) states that equipment listed for Zone 0 can be installed in Zone 1 and Zone 2. The phrase "provided that it is installed in accordance with the requirements for the marked type of protection" was added in 2005. This phrase was also added after the sentence saying that Zone 1 equipment can be installed in Zone 2 locations.

This phrase was added primarily to avoid confusion on installing intrinsically safe equipment. Intrinsically safe apparatus listed and

marked only for Zone 0 needs to be used with the associated apparatus for Zone 0 specified on its control drawing, even if the intrinsically safe apparatus is installed in Zone 1 or Zone 2. If the installation for Zone 1 and/or Zone 2 uses different associated apparatus, it needs to be separately listed and marked for Zone 1 and/or Zone 2, and the specifications for the Zone 1 and/or Zone 2 associated apparatus need to be listed on the control drawing as well.

(C) Marking. Equipment shall be marked in accordance with 505.9(C)(1) or (C)(2).

(1) Division Equipment. Equipment identified for Class I, Division 1 or Class I, Division 2 shall, in addition to being marked in accordance with 500.8(C), be permitted to be marked with all of the following:

- (1) Class I, Zone 1 or Class I, Zone 2 (as applicable)
- (2) Applicable gas classification group(s) in accordance with Table 505.9(C)(1)(2)
- (3) Temperature classification in accordance with 505.9(D)(1)

Table 505.9(C)(1)(2) Material Groups

Material Group	Comment
IIC	See 505.6(A)
IIB	See 505.6(B)
IIA	See 505.6(C)

(2) Zone Equipment. Equipment meeting one or more of the protection techniques described in 505.8 shall be marked with all of the following in the order shown:

- (1) Class
- (2) Zone
- (3) Symbol "AEx"
- (4) Protection technique(s) in accordance with Table 505.9(C)(2)(4)
- (5) Applicable material group in accordance with Table 505.9(C)(1)(2) or a specific gas or vapor
- (6) Temperature classification in accordance with 505.9(D)(1)

Exception No. 1: Associated apparatus NOT suitable for installation in a hazardous (classified) location shall be required to be marked only with (3), (4), and (5), but BOTH the symbol AEx (3) and the symbol for the type of protection (4) shall be enclosed within the same square brackets, for example, [AEx ia] IIC.

Exception No. 2: Simple apparatus as defined in 504.2 shall not be required to have a marked operating temperature or temperature class.

Exception No. 3: Fittings for the termination of cables shall not be required to have a marked operating temperature or temperature class.

Exception No. 1 to Section 505.9(C)(2)(6) clarifies the use of the square brackets in the marking requirements for intrinsically safe associated apparatus. If the associated apparatus is designed to be installed in the hazardous location, it has to use another method of protection to protect the associated apparatus, and only the output of the hazardous area terminals is intrinsically safe and can use

INTERPRETATION OF ARTICLE 505: CLASS I, ZONE 0, 1, AND 2 LOCATIONS

intrinsically safe wiring methods.

For example, associated apparatus that is inside a flameproof housing with an intrinsically safe output suitable for Zone 0 would be marked AExd[ia]. Since the associated apparatus is flameproof, or AExd, the equipment can be installed in a Zone 1 location. The intrinsically safe output is acceptable for Zone 0, so it can be wired from the Zone 1 location into a Zone 0 location; using intrinsically safe wiring methods from the AExd Zone 1 installation into the Zone 0 location (after passing through an explosionproof seal to leave the AExd enclosure). Zone 1 wiring methods must be used to connect the AExd installation to the unclassified location.

Exception No. 2 of Section 505.9(C)(2)(6) was added to clarify that simple apparatus, as defined in Article 504, is not marked for use in hazardous locations. Even though the potential temperature rise of the simple apparatus must be evaluated using information from the associated apparatus control drawing, a temperature class or operating temperature is not marked.

Exception No. 3 of Section 505.9(C)(2)(6) clarifies that cable fittings are not required to be marked with a temperature classification as they are non-heat producing equipment.

This Section includes all of the current Zone 0, 1, and 2 protection techniques based on the revised product standards.

Informational Note No. 1: An example of the required marking for intrinsically safe apparatus for installation in Class I, Zone 0 is "Class I, Zone 0, AEx ia IIC T6." An explanation of the marking that is required is shown in Informational Note Figure 505.9(C)(2), No.1.

Informational Note No. 2: An example of the required marking for intrinsically safe associated apparatus mounted in a flameproof enclosure for installation in Class I, Zone 1 is "Class I, Zone 1 AEx d[ia] IIC T4."

Informational Note No. 3: An example of the required marking for intrinsically safe associated apparatus NOT for installation in a hazardous (classified) location is "[AEx ia] IIC."

Informational Note No. 4: The EPL (or equipment protection level) may appear in the product marking. EPLs are designated as G for gas, D for dust, or M for mining and are then followed by a letter (a, b, or c) to give the user a better understanding as to whether the equipment provides either (a) a "very high," (b) a "high," or (c) an "enhanced" level of protection against ignition of an explosive atmosphere. For example, an AEx d IIC T4 motor (which is suitable by protection concept for application in Zone 1) may additionally be marked with an EPL of "Gb" to indicate that it was provided with a high level of protection, such as AEx d IIC T4 Gb.

Informational Note No. 5: Equipment installed outside a Zone 0 location, electrically connected to equipment located inside a Zone 0 location, may be marked Class I, Zone 0/1. The "0/1" indicates that equipment contains a separation element and can be installed at the boundary between a Zone 0 and a Zone 1 location. See ANSI/ISA-60079-26, *Electrical Apparatus for Use in Class I, Zone 0 Hazardous (Classified) Locations*.

The Informational Note to Section 505.9(C)(2) clarifies that the example cited was for intrinsically safe apparatus. Informational Notes 2 and 3 were added to clarify the use of the square brackets in the marking, to distinguish intrinsically safe associated apparatus that is to be installed in the hazardous location, from associated apparatus that is to be installed in an unclassified location.

(D) Class I Temperature. The temperature marking specified in 505.9(D)(1) shall not exceed the autoignition temperature of the specific gas or vapor to be encountered.

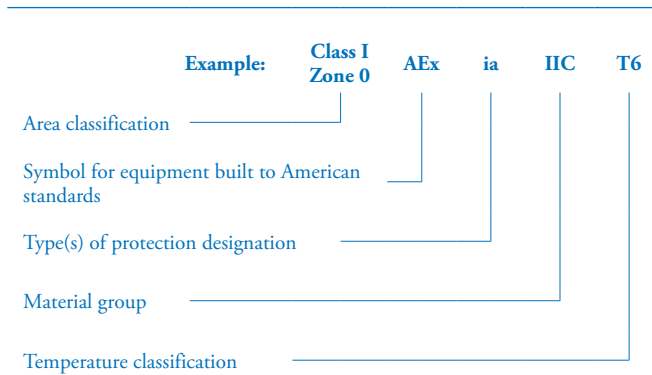

Informational Note Figure 505.9(C)(2), No. 1, Zone Equipment Marking.



**UNICODE® 2 SERIES CONTROL STATION
CLASS I, ZONE 1 AEx dem IIC T6**

Informational Note: For information regarding autoignition temperatures of gases and vapors, see NFPA 497-2012, *Recommended Practice for the Classification of Flammable Liquids, Gases, or Vapors and of Hazardous (Classified) Locations for Electrical Installations in Chemical Process Areas*; and IEC 60079-20-1996, *Electrical Apparatus for Explosive Gas Atmospheres, Data for Flammable Gases and Vapours, Relating to the Use of Electrical Apparatus*.

(1) Temperature Classifications. Equipment shall be marked to show the operating temperature or temperature class referenced to a 40°C ambient, or at the higher ambient temperature if the equipment is rated and marked for an ambient temperature of greater than 40°C. The temperature class, if provided, shall be indicated using the temperature class (T code) shown in Table 505.9(D)(1).

The table includes the EPL (Equipment Protection Levels) for the relevant Types of Protection Designations. This was required as the product standards now contain these markings.

Electrical equipment designed for use in the ambient temperature range between -20°C and +40°C shall require no ambient temperature marking.

This section clarifies that when there is no marked ambient temperature, then the suitable ambient temperatures that the equipment has been evaluated for is -25°C to +40°C.

Electrical equipment that is designed for use in a range of ambient temperatures other than -20°C to +40°C is considered to be special; and

INTERPRETATION OF ARTICLE 505: CLASS I, ZONE 0, 1, AND 2 LOCATIONS

Table 505.9(C)(2)(4) Types of Protection Designation

Designation	Technique	Zone*
d	Flameproof enclosure	1
db	Flameproof enclosure	1
e	Increased safety	1
eb	Increased safety	1
ia	Intrinsic safety	0
ib	Intrinsic safety	1
ic	Intrinsic safety	2
[ia]	Associated apparatus	Unclassified**
[ib]	Associated apparatus	Unclassified**
[ic]	Associated apparatus	Unclassified**
ma	Encapsulation	0
m	Encapsulation	1
mb	Encapsulation	1
mc	Encapsulation	2
nA	Nonsparking equipment	2
nAc	Nonsparking equipment	2
nC	Sparking equipment in which the contacts are suitably protected other than by restricted breathing enclosure	2
nCc	Sparking equipment in which the contacts are suitably protected other than by restricted breathing enclosure	2
nR	Restricted breathing enclosure	2
nRc	Restricted breathing enclosure	2
o	Oil immersion	1
ob	Oil immersion	1
px	Pressurization	1
pxb	Pressurization	1
py	Pressurization	1
pyb	Pressurization	1
pz	Pressurization	2
pzc	Pressurization	2
q	Powder filled	1
qb	Powder filled	1

*Does not address use where a combination of techniques is used.

**Associated apparatus is permitted to be installed in a hazardous (classified) location if suitably protected using another type of protection.

the ambient temperature range shall then be marked on the equipment, including either the symbol “Ta” or “Tamb” together with the special range of ambient temperatures, in degrees Celsius.

Informational Note: As an example, such a marking might be “-30°C to +40°C.”

Exception No. 1: Equipment of the non-heat-producing type, such as conduit fittings, and equipment of the heat-producing type having a maximum temperature of not more than 100°C (212°F) shall not be required to have a marked operating temperature or temperature class.

Exception No. 2: Equipment identified for Class I, Division 1 or Division

Table 505.9(D)(1) Classification of Maximum Surface Temperature for Group II Electrical Equipment

Temperature Class (T Code)	Maximum Surface Temperature (°C)
T1	≤ 450
T2	≤ 300
T3	≤ 200
T4	≤ 135
T5	≤ 100
T6	≤ 85

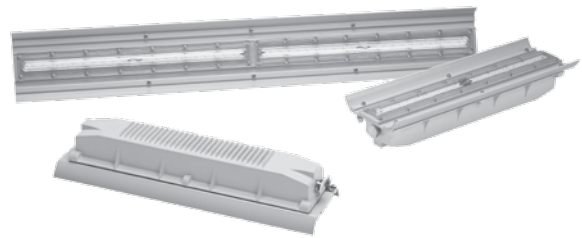

VIAMASTER™ LED SERIES LUMINAIRES
 NEC/CEC — CLASS I, DIVISION 2, GROUPS A, B, C, D;
 CLASS I, ZONE 2, AEx nA IIC; Ex nA IIC;
 SIMULTANEOUS EXPOSURE (CLASS I, DIVISION 2/CLASS II, DIVISION 1);
 TYPE 3R, 4X; WET LOCATIONS; IP66
 ATEX/IECEX — ZONES 2 and 22; Ex II 3 GD; EPL Gc AND Dc; Ex nA IIC;
 Ex tc IIC; IK08; IP66
 ATEX/IECEX — ZONE 21; Ex II 2 D; EPL Db; Ex tb IIC; IK08



MERCMASTER LED LUMINAIRE
 NEC/CEC — CLASS I, DIVISION 2, GROUPS A, B, C, D;
 CLASS I, ZONE 2; TYPE 3R, 4X; IP66, IP67
 IEC/ATEX — ZONE 2 AND 22; Ex II 3 GD; AATEX/IECEX; IP66

2 locations as permitted by 505.20(A), (B), and (C) shall be permitted to be marked in accordance with 505.8(C) and Table 500.8(C).

(E) Threading. The supply connection entry thread form shall be NPT or metric. Conduit and fittings shall be made wrenchtight to prevent sparking when fault current flows through the conduit system, and to ensure the explosionproof or flameproof integrity of the conduit system where applicable. Equipment provided with threaded entries for field wiring connections shall be installed in accordance with 505.9(E)(1) or (E)(2) and with (E)(3).

INTERPRETATION OF ARTICLE 505: CLASS I, ZONE 0, 1, AND 2 LOCATIONS

(1) Equipment Provided with Threaded Entries for NPT Threaded Conduit or Fittings. For equipment provided with threaded entries for NPT threaded conduit or fittings, listed conduit, listed conduit fittings, or listed cable fittings shall be used.

Section clarifies that not only is the conduit required to be “listed” but also the conduit fittings and cable fittings.

All NPT threaded conduit and fittings referred to herein shall be threaded with a National (American) Standard Pipe Taper (NPT) thread.

NPT threaded entries into explosionproof or flameproof equipment shall be made up with at least five threads fully engaged.

Exception: For listed explosionproof or flameproof equipment, factory threaded NPT entries shall be made up with at least 4 1/2 threads fully engaged.

Informational Note No. 1: Thread specifications for male NPT threads are located in ANSI/ASME B1.20.1-1983, *Pipe Threads, General Purpose (Inch)*.

Informational Note No. 2: Female NPT threaded entries use a modified National Standard Pipe Taper (NPT) thread with thread form per ANSI/ASME B1.20.1-1983, *Pipe Threads, General Purpose (Inch)*. See ANSI UL/ISA 60079-1, *Electrical Apparatus for Explosive Gas Atmospheres — Part 1: Flameproof Enclosures “d.”*

(2) Equipment Provided with Threaded Entries for Metric Threaded Conduit or Fittings. For equipment with metric threaded entries, listed conduit fittings or listed cable fittings shall be used. Such entries shall be identified as being metric, or listed adapters to permit connection to conduit or NPT threaded fittings shall be provided with the equipment and shall be used for connection to conduit or NPT threaded fittings.

Metric threaded entries into explosionproof or flameproof equipment shall have a class of fit of at least 6g/6H and be made up with at least five threads fully engaged for Groups C, D, IIB, or IIA and not less than eight threads fully engaged for Groups A, B, IIC, or IIB + H₂.

Informational Note: Threading specifications for metric threaded entries are located in ISO 965/1-1980, *ISO general purpose metric screw threads — Tolerances — Part 1: Principles and basic data*; and ISO 965-3-1998, *ISO general purpose metric screw threads — Tolerances — Part 3: Deviations for constructional screw threads*; and ISO 965/3-1980, *Metric Screw Threads*.

This section requires that metric threaded entries shall have a specified class of fit of 6g/6H and that a minimum required number of thread are engaged based on the Group Classifications. This metric fit Class is similar to the unified straight thread Class 2 fit.

(3) Unused Openings. All unused openings shall be closed with close-up plugs listed for the location and shall maintain the type of protection. The plug engagement shall comply with 505.9(E)(1) or 505.9(E)(2).

This section addresses the requirements for close-up plugs used to close unused openings. The section requires these plugs to be “listed” and that a specified thread engagement is provided

(F) Optical Fiber Cables. Where an optical fiber cable contains conductors that are capable of carrying current (composite optical fiber cable), the optical fiber cable shall be installed in accordance with the requirements of Articles 505.15 and 505.16.

This section addresses the proper wiring methods and sealing requirements for fiber optic cable assemblies installed in a Class I, Zone rated area.

505.15 Wiring Methods. Wiring methods shall maintain the integrity of protection techniques and shall comply with 505.15(A) through (C).

(A) Class I, Zone 0. In Class I, Zone 0 locations, only intrinsically safe wiring methods in accordance with Article 504 shall be permitted.

Per Table 505.9(C)(2)(4) Types of Protection Designation Intrinsic Safety “ia” and Encapsulation “ma” are permitted protection techniques for Zone 0.

(B) Class I, Zone 1.

(1) General. In Class I, Zone 1 locations, the wiring methods in (B)(1)(a) through (B)(1)(i) shall be permitted.

(a) All wiring methods permitted by 505.15(A).

Class I, Zone 0 wiring methods are permitted in Class I, Zone 1 locations.

(b) In industrial establishments with restricted public access, where the conditions of maintenance and supervision ensure that only qualified persons service the installation, and where the cable is not subject to physical damage, Type MC-HL cable listed for use in Class I, Zone 1 or Division 1 locations, with a gas/vaportight continuous corrugated metallic sheath, an overall jacket of suitable polymeric material, and a separate equipment grounding conductor(s) in accordance with 250.122, and terminated with fittings listed for the application. Type MC-HL cable shall be installed in accordance with the provisions of Article 330, Part II.

(c) In industrial establishments with restricted public access, where the conditions of maintenance and supervision ensure that only qualified persons service the installation, and where the cable is not subject to physical damage, Type ITC-HL cable listed for use in Class I, Zone 1 or Division 1 locations, with a gas/vaportight continuous corrugated metallic sheath and an overall jacket of suitable polymeric material, and terminated with fittings listed for the application. Type ITC-HL cable shall be installed in accordance with the provisions of Article 727.

Informational Note: See 727.4 and 727.5 for restrictions on use of Type ITC cable.

This Section specifically requires the use of termination fittings that are “listed for the location”.

(d) Type MI cable terminated with fittings listed for Class I, Zone 1 or Division 1 locations. Type MI cable shall be installed and supported in a manner to avoid tensile stress at the termination fittings.

(e) Threaded rigid metal conduit, or threaded steel intermediate metal conduit.

(f) Type PVC conduit and Type RTRC conduit shall be permitted



TMC2X CABLE CONNECTOR
CLASS I, ZONE 1 AEx d IIC

INTERPRETATION OF ARTICLE 505: CLASS I, ZONE 0, 1, AND 2 LOCATIONS

where encased in a concrete envelope a minimum of 50 mm (2 in.) thick and provided with not less than 600 mm (24 in.) of cover measured from the top of the conduit to grade. Threaded rigid metal conduit or threaded steel intermediate metal conduit shall be used for the last 600 mm (24 in.) of the underground run to emergence or to the point of connection to the aboveground raceway. An equipment grounding conductor shall be included to provide for electrical continuity of the raceway system and for grounding of non-current-carrying metal parts.

(g) Intrinsic safety type of protection “ib” shall be permitted using the wiring methods specified in Article 504.

Informational Note: For entry into enclosures required to be flameproof, explosionproof, or of increased safety, see the information on construction, testing, and marking of cables; flameproof and increased safety cable fittings; and flameproof and increased safety cord connectors in ANSI/UL 2225-2011, Cables and Cable-Fittings for Use in Hazardous (Classified) Locations.

(h) Optical fiber cable Types OFNP, OFCP, OFNR, OFCR, OFNG, OFCG, OFN, and OFC shall be permitted to be installed in raceways in accordance with 505.15(B). Optical fiber cable shall be sealed in accordance with 505.16.

Informational Note: For entry into enclosures required to be flameproof, explosionproof, or of increased safety, see the information on construction, testing, and marking of cables; flameproof and increased safety cable fittings; and flameproof and increased safety cord connectors in ANSI/UL 2225-2011, Cables and Cable-Fittings for Use in Hazardous (Classified) Locations.

Section 770.3(A) permits the use of Listed optical fiber cables in Hazardous (Classified) Locations providing they are sealed in accordance with the requirements in Chapter 5. Subsection (h) has been added to ensure the specific requirements for sealing these cables are known.

(i) In industrial establishments with restricted public access, where the conditions of maintenance and supervision ensure that only qualified persons service the installation, for applications limited to 600 volts nominal or less, for cable diameters 25 mm (1 in.) or less, and where the cable is not subject to physical damage, Type TC-ER-HL cable listed for use in Class I, Zone 1 locations, with an overall jacket and a separate equipment grounding conductor(s) in accordance with 250.122, and terminated with fittings listed for the location, Type TC-ER-HL cable shall be installed in accordance with the provisions of Article 336, including the restrictions of 336.10(7).

Many types of wiring methods permitted in Section 505.15(B)(1) are not a practical method for connection to equipment that are rated for Class I, Zone 1. Type TC-ER-HL cables are a good method to make these connections and meet crush resistance requirements.

(2) Flexible Connections. Where necessary to employ flexible connections, flexible fittings listed for Class I, Zone 1 or Division



TMC2 CABLE CONNECTOR
CLASS I, ZONE 1 AEx e II

1 locations, or flexible cord in accordance with the provisions of 505.17(A) terminated with a listed cord connector that maintains the type of protection of the terminal compartment, shall be permitted.

(C) Class I, Zone 2.

(1) General. In Class I, Zone 2 locations, the following wiring methods shall be permitted.

(a) All wiring methods permitted by 505.15(B).

(b) Types MC, MV, TC, or TC-ER cable, including installation in cable tray systems. The cable shall be terminated with listed fittings. Single conductor Type MV cables shall be shielded or metallic-armored.

TC-ER cable has been added as a permissible wiring method for Class I, Zone 2 as the other extended run cables had been permitted such as PLTC-ER and ITC-ER which are all constructed to the same strength requirements.

(c) Type ITC and Type ITC-ER cable as permitted in 727.4 and terminated with listed fittings.

Shielding or metal armored single conductor cable is required to prevent it from inducing currents in adjacent conductors. Section 505.15(C)(c) references Section 727.4 for ITC cable installation.

(d) Type PLTC and Type PLTC-ER cable in accordance with the provisions of Article 725, including installation in cable tray systems. The cable shall be terminated with listed fittings.

(e) Enclosed gasketed busways, enclosed gasketed wireways.

(f) In industrial establishments with restricted public access, where the conditions of maintenance and supervision ensure that only qualified persons service the installation, and where metallic conduit does not provide sufficient corrosion resistance, listed reinforced thermosetting resin conduit (RTRC), factory elbows, and associated fittings, all marked with the suffix -XW, and Schedule 80 PVC conduit, factory elbows, and associated fittings shall be permitted. Where seals are required for boundary conditions as defined in 505.16(C)(1)(b), the Zone 1 wiring method shall extend into the Zone 2 area to the seal, which shall be located on the Zone 2 side of the Zone 1/Zone 2 boundary.

This Section permits RTRC conduit and Schedule 80 PVC conduit in Class I, Zone 2 areas of industrial establishments and where additional corrosion resistance is required. RTRC conduit is required to be “listed”.

(g) Intrinsic safety type of protection “ic” shall be permitted using any of the wiring methods permitted for unclassified locations. Intrinsic safety type of protection “ic” systems shall be installed in accordance with the control drawing(s). Simple apparatus, not shown on the control drawing, shall be permitted in an intrinsic safety type of protection “ic” circuit, provided that the simple apparatus does not interconnect the intrinsic safety type of protection “ic” systems to any other circuit.

Informational Note: Simple apparatus is defined in 504.2.

(h) Optical fiber cable of Types OFNP, OFCP, OFNR, OFCR, OFNG, OFCG, OFN, and OFC shall be permitted to be installed in cable trays or any other raceway in accordance with 505.15(C). Optical fiber cable shall be sealed in accordance with 505.16.

Optical fiber cable of the types listed in Subsection (h) has been added

INTERPRETATION OF ARTICLE 505: CLASS I, ZONE 0, 1, AND 2 LOCATIONS

as a permissible wiring method for Class I, Zone 2 locations.

Separate intrinsic safety type of protection “ic” systems shall be installed in accordance with one of the following:

- (1) In separate cables
- (2) In multiconductor cables where the conductors of each circuit are within a grounded metal shield
- (3) In multiconductor cables where the conductors of each circuit have insulation with a minimum thickness of 0.25 mm (0.01 in.)

This section permits a relatively new protection technique for Zone 2 locations. The “ic” and “[ic]” methods are contained in the ANSI standard for Intrinsic Safety.

(2) Flexible Connections. Where provision must be made for flexibility, flexible metal fittings, flexible metal conduit with listed fittings, liquidtight flexible metal conduit with listed fittings, liquidtight flexible nonmetallic conduit with listed fittings, or flexible cord in accordance with the provisions of 505.17 terminated with a listed cord connector that maintains the type of protection of the terminal compartment shall be permitted.

Informational Note: See 505.25(B) for grounding requirements where flexible conduit is used.

Exception: For elevator use, an identified elevator cable of Type EO, ETP, or ETT, shown under the “use” column in Table 400.4 for “hazardous (classified) locations,” that is terminated with listed connectors that maintain the type of protection of the terminal compartment, shall be permitted.

Type EO, ETP, or ETT are now specifically permitted in the Section for elevator use as these are recognized in Table 400.4 for hazardous (Classified) locations.

505.16 Sealing and Drainage. Seals in conduit and cable systems shall comply with 505.16(A) through (E). Sealing compound shall be used in Type MI cable termination fittings to exclude moisture and other fluids from the cable insulation.

Informational Note No. 1: Seals are provided in conduit and cable systems to minimize the passage of gases and vapors and prevent the passage of flames from one portion of the electrical installation to another through the conduit. Such communication through Type MI cable is inherently prevented by construction of the cable. Unless specifically designed and tested for the purpose, conduit and cable seals are not intended to prevent the passage of liquids, gases, or vapors at a continuous pressure differential across the seal. Even at differences in pressure across the seal equivalent to a few inches of water, there may be a slow passage of gas or vapor through a seal and through conductors passing through the seal. See 505.16(C)(2)(b). Temperature extremes and highly corrosive liquids and vapors can affect the ability of seals to perform their intended function. See 505.16(D)(2).

Informational Note No. 2: Gas or vapor leakage and propagation of flames may occur through the interstices between the strands of standard stranded conductors larger than 2 AWG. Special conductor constructions, for example, compacted strands or sealing of the individual strands, are means of reducing leakage and preventing the propagation of flames.

(A) Zone 0. In Class I, Zone 0 locations, seals shall be located according to 505.16(A)(1), (A)(2), and (A)(3).

(1) Conduit Seals. Seals shall be provided within 3.05 m (10 ft) of where a conduit leaves a Zone 0 location. There shall be no unions, couplings, boxes, or fittings, except listed reducers at the seal, in the

conduit run between the seal and the point at which the conduit leaves the location.

Exception: A rigid unbroken conduit that passes completely through the Zone 0 location with no fittings less than 300 mm (12 in.) beyond each boundary shall not be required to be sealed if the termination points of the unbroken conduit are in unclassified locations.

(2) Cable Seals. Seals shall be provided on cables at the first point of termination after entry into the Zone 0 location.

(3) Not Required to Be Explosionproof or Flameproof. Seals shall not be required to be explosionproof or flameproof.

(B) Zone 1. In Class I, Zone 1 locations, seals shall be located in accordance with 505.16(B)(1) through (B)(8).

(1) Type of Protection “d” or “e” Enclosures. Conduit seals shall be provided within 50 mm (2 in.) for each conduit entering enclosures having type of protection “d” or “e.”

Exception No. 1: Where the enclosure having type of protection “d” is marked to indicate that a seal is not required.

Exception No. 2: For type of protection “e,” conduit and fittings employing only NPT to NPT raceway joints or fittings listed for type of protection “e” shall be permitted between the enclosure and the seal, and the seal shall not be required to be within 50 mm (2 in.) of the entry.

Informational Note: Examples of fittings employing other than NPT threads include conduit couplings, capped elbows, unions, and breather drains.

Exception No. 3: For conduit installed between type of protection “e” enclosures employing only NPT to NPT raceway joints or conduit fittings listed for type of protection “e,” a seal shall not be required.

Section 505.16(B)(1) requires a conduit seal within 50 mm (2 in.) of a type “d” or “e” enclosure, instead of just stating that seals are required.

Exceptions 2 and 3 are to make type “e” equipment easier to install in Zone 1 locations.

Exception 2 to Section 505.16(B)(1) allows a close nipple, elbow, or other NPT threaded fitting to be used between a type “e” enclosure and the conduit seal, thus allowing the seal to be more than 50 mm (2 in.) from the enclosure. This is allowable because type “e” equipment is designed to prevent ignitions from occurring by using widely spaced terminals that are mechanically protected from loosening in service. The enclosures of type “e” equipment are not designed to contain an explosion like type “d” enclosures are. The distance that a conduit seal is located from the enclosure can affect the explosion pressure inside a type “d” enclosure, but is not a factor in a type “e” enclosure. There are often many connections made to type “e” junction boxes, and allowing the conduit seal to be further away from the type “e” enclosure makes installation much easier.

Because of the fact that explosions do not occur in type “e” enclosures and explosion pressure is not an issue, Exception 3 to Section 505.16(B)(1) allows the conduit seal to be eliminated when type “e” enclosures are connected only to each other, using conduit and fittings with NPT joints only. Seals are still required if one end of the conduit is connected to a type “d” enclosure or crosses an area classification boundary.

(2) Explosionproof Equipment. Conduit seals shall be provided for each conduit entering explosionproof equipment according to

INTERPRETATION OF ARTICLE 505: CLASS I, ZONE 0, 1, AND 2 LOCATIONS

505.16(B)(2)(a), (B)(2)(b), and (B)(2)(c).

(a) In each conduit entry into an explosionproof enclosure where either (1) the enclosure contains apparatus, such as switches, circuit breakers, fuses, relays, or resistors, that may produce arcs, sparks, or high temperatures that are considered to be an ignition source in normal operation, or (2) the entry is metric designator 53 (trade size 2) or larger and the enclosure contains terminals, splices, or taps. For the purposes of this section, high temperatures shall be considered to be any temperatures exceeding 80 percent of the autoignition temperature in degrees Celsius of the gas or vapor involved.

Exception: Conduit entering an enclosure where such switches, circuit breakers, fuses, relays, or resistors comply with one of the following:

(1) Are enclosed within a chamber hermetically sealed against the entrance of gases or vapors.

(2) Are immersed in oil.

(3) Are enclosed within a factory-sealed explosionproof chamber located within the enclosure, identified for the location, and marked "factory sealed" or equivalent, unless the entry is metric designator 53 (trade size 2) or larger. Factory-sealed enclosures shall not be considered to serve as a seal for another adjacent explosionproof enclosure that is required to have a conduit seal.

(b) Conduit seals shall be installed within 450 mm (18 in.) from the enclosure. Only explosionproof unions, couplings, reducers, elbows, capped elbows, and conduit bodies similar to L, T, and cross types that are not larger than the trade size of the conduit shall be permitted between the sealing fitting and the explosionproof enclosure.

(c) Where two or more explosionproof enclosures for which conduit seals are required under 505.16(B)(2) are connected by nipples or by runs of conduit not more than 900 mm (36 in.) long, a single conduit seal in each such nipple connection or run of conduit shall be considered sufficient if located not more than 450 mm (18 in.) from either enclosure.

(3) Pressurized Enclosures. Conduit seals shall be provided in each conduit entry into a pressurized enclosure where the conduit is not pressurized as part of the protection system. Conduit seals shall be installed within 450 mm (18 in.) from the pressurized enclosure.

Informational Note No. 1: Installing the seal as close as possible to the enclosure reduces problems with purging the dead airspace in the pressurized conduit.

Informational Note No. 2: For further information, see NFPA 496-2013, *Standard for Purged and Pressurized Enclosures for Electrical Equipment*.

(4) Class I, Zone 1 Boundary. Conduit seals shall be provided in each conduit run leaving a Class I, Zone 1 location. The sealing fitting shall be permitted on either side of the boundary of such location within 3.05 m (10 ft) of the boundary and shall be designed and installed so as to minimize

the amount of gas or vapor within the Zone 1 portion of the conduit from being communicated to the conduit beyond the seal. Except for listed explosionproof reducers at the conduit seal, there shall be no union, coupling, box, or fitting between the conduit seal and the point at which the conduit leaves the Zone 1 location.

Exception: Metal conduit containing no unions, couplings, boxes, or fittings and passing completely through a Class I, Zone 1 location with no fittings less than 300 mm (12 in.) beyond each boundary shall not require a conduit seal if the termination points of the unbroken conduit are in

unclassified locations.

(5) Cables Capable of Transmitting Gases or Vapors. Conduits containing cables with a gas/vaportight continuous sheath capable of transmitting gases or vapors through the cable core shall be sealed in the Zone 1 location after removing the jacket and any other coverings so that the sealing compound surrounds each individual insulated conductor or optical fiber tube and the outer jacket.

Exception: Multiconductor cables with a gas/vaportight continuous sheath capable of transmitting gases or vapors through the cable core shall be permitted to be considered as a single conductor by sealing the cable in the conduit within 450 mm (18 in.) of the enclosure and the cable end within the enclosure by an approved means to minimize the entrance of gases or vapors and prevent the propagation of flame into the cable core, or by other approved methods. For shielded cables and twisted pair cables, it shall not be required to remove the shielding material or separate the twisted pair.

(6) Cables Incapable of Transmitting Gases or Vapors. Each multiconductor or optical multifiber cable in conduit shall be considered as a single conductor or single optical fiber tube if the cable is incapable of transmitting gases or vapors through the cable core. These cables shall be sealed in accordance with 505.16(D).

(7) Cables Entering Enclosures. Cable seals shall be provided for each cable entering flameproof or explosionproof enclosures. The seal shall comply with 505.16(D).

(8) Class I, Zone 1 Boundary. Cables shall be sealed at the point at which they leave the Zone 1 location.

Exception: Where cable is sealed at the termination point.

(C) Zone 2. In Class I, Zone 2 locations, seals shall be located in accordance with 505.16(C)(1) and (C)(2).

(1) Conduit Seals. Conduit seals shall be located in accordance with (C)(1)(a) and (C)(1)(b).

(a) For connections to enclosures that are required to be flameproof or explosionproof, a conduit seal shall be provided in accordance with 505.16(B)(1) and (B)(2). All portions of the conduit run or nipple between the seal and enclosure shall comply with 505.16(B).

(b) In each conduit run passing from a Class I, Zone 2 location into an unclassified location. The sealing fitting shall be permitted on either side of the boundary of such location within 3.05 m (10 ft) of the boundary and shall be designed and installed so as to minimize the amount of gas or vapor within the Zone 2 portion of the conduit from being communicated to the conduit beyond the seal. Rigid metal conduit or threaded steel intermediate metal conduit shall be used between the sealing fitting and the point at which the conduit leaves the Zone 2 location, and a threaded connection shall be used at the sealing fitting. Except for listed explosionproof reducers at the conduit seal, there shall be no union, coupling, box, or fitting between the conduit seal and the point at which the conduit leaves the Zone 2 location. Conduits shall be sealed to minimize the amount of gas or vapor within the Class I, Zone 2 portion of the conduit from being communicated to the conduit beyond the seal. Such seals shall not be required to be flameproof or explosionproof but shall be identified for the purpose of minimizing passage of gases under normal operating conditions and shall be accessible.

This Section correlates with the purpose explanation of seals that is also found in Article 501.

INTERPRETATION OF ARTICLE 505: CLASS I, ZONE 0, 1, AND 2 LOCATIONS

Exception No. 1: Metal conduit containing no unions, couplings, boxes, or fittings and passing completely through a Class I, Zone 2 location with no fittings less than 300 mm (12 in.) beyond each boundary shall not be required to be sealed if the termination points of the unbroken conduit are in unclassified locations.

Exception No. 2: Conduit systems terminating at an unclassified location where a wiring method transition is made to cable tray, cablebus, ventilated busway, Type MI cable, or cable that is not installed in a raceway or cable tray system shall not be required to be sealed where passing from the Class I, Zone 2 location into the unclassified location. The unclassified location shall be outdoors or, if the conduit system is all in one room, it shall be permitted to be indoors. The conduits shall not terminate at an enclosure containing an ignition source in normal operation.

Exception No. 3: Conduit systems passing from an enclosure or room that is unclassified as a result of pressurization into a Class I, Zone 2 location shall not require a seal at the boundary.

Informational Note: For further information, refer to NFPA 496-2013, *Standard for Purged and Pressurized Enclosures for Electrical Equipment*.

Exception No. 4: Segments of aboveground conduit systems shall not be required to be sealed where passing from a Class I, Zone 2 location into an unclassified location if all the following conditions are met:

(1) No part of the conduit system segment passes through a Zone 0 or Zone 1 location where the conduit contains unions, couplings, boxes, or fittings within 300 mm (12 in.) of the Zone 0 or Zone 1 location.

(2) The conduit system segment is located entirely in outdoor locations.

(3) The conduit system segment is not directly connected to canned pumps, process or service connections for flow, pressure, or analysis measurement, and so forth, that depend on a single compression seal, diaphragm, or tube to prevent flammable or combustible fluids from entering the conduit system.

(4) The conduit system segment contains only threaded metal conduit, unions, couplings, conduit bodies, and fittings in the unclassified location.

(5) The conduit system segment is sealed at its entry to each enclosure or fitting housing terminals, splices, or taps in Zone 2 locations.

(2) **Cable Seals.** Cable seals shall be located in accordance with (C)(2)(a), (C)(2)(b), and (C)(2)(c).

(a) **Explosionproof and Flameproof Enclosures.** Cables entering enclosures required to be flameproof or explosionproof shall be sealed at the point of entrance. The seal shall comply with 505.16(D). Multiconductor or optical multifiber cables with a gas/vaportight continuous sheath capable of transmitting gases or vapors through the cable core shall be sealed in the Zone 2 location after removing the jacket and any other coverings so that the sealing compound surrounds each individual insulated conductor or optical fiber tube in such a manner as to minimize the passage of gases and vapors. Multiconductor or optical multifiber cables in conduit shall be sealed as described in 505.16(B)(4).

Exception No. 1: Cables passing from an enclosure or room that is unclassified as a result of Type Z pressurization into a Zone 2 location shall not require a seal at the boundary.

Exception No. 2: Shielded cables and twisted pair cables shall not require the removal of the shielding material or separation of the twisted pairs, provided the termination is by an approved means to minimize the entrance of gases or vapors and prevent propagation of flame into the cable core.

(b) **Cables That Will Not Transmit Gases or Vapors.** Cables with a gas/vaportight continuous sheath and that will not transmit gases or vapors through the cable core in excess of the quantity permitted for seal fittings shall not be required to be sealed except as required in 505.16(C)(2)(a). The minimum length of such cable run shall not be less than the length that limits gas or vapor flow through the cable core to the rate permitted for seal fittings [200 cm³/hr (0.007 ft³/hr) of air at a pressure of 1500 pascals (6 in. of water)].

Informational Note No. 1: For further information on construction, testing, and marking of cables, cable fittings, and cord connectors, see ANSI/UL 2225-2011, *Cables and Cable-Fittings for Use in Hazardous (Classified) Locations*.

Informational Note No. 2: The cable core does not include the interstices of the conductor strands.

(c) **Cables Capable of Transmitting Gases or Vapors.** Cables with a gas/vaportight continuous sheath capable of transmitting gases or vapors through the cable core shall not be required to be sealed except as required in 505.16(C)(2)(a), unless the cable is attached to process equipment or devices that may cause a pressure in excess of 1500 pascals (6 in. of water) to be exerted at a cable end, in which case a seal, barrier, or other means shall be provided to prevent migration of flammables into an unclassified area.

Exception: Cables with an unbroken gas/vaportight continuous sheath shall be permitted to pass through a Class I, Zone 2 location without seals.

(d) **Cables Without Gas/Vaportight Continuous Sheath.** Cables that do not have gas/vaportight continuous sheath shall be sealed at the boundary of the Zone 2 and unclassified location in such a manner as to minimize the passage of gases or vapors into an unclassified location.

Informational Note: The cable sheath may be either metal or a nonmetallic material.

(D) **Class I, Zones 0, 1, and 2.** Where required, seals in Class I, Zones 0, 1, and 2 locations shall comply with 505.16(D)(1) through (D)(5).

(1) **Fittings.** Enclosures for connections or equipment shall be provided with an integral means for sealing, or sealing fittings listed for the location shall be used. Sealing fittings shall be listed for use with one or more specific compounds

and shall be accessible.

(2) **Compound.** The compound shall provide a seal against passage of gas or vapors through the seal fitting, shall not be affected by the surrounding atmosphere or liquids, and shall not have a melting point less than 93°C (200°F).

(3) **Thickness of Compounds.** In a completed seal, the minimum thickness of the sealing compound shall not be less than the trade size of the sealing fitting and, in no case, less than 16 mm (5/8 in.).

Exception: Listed cable sealing fittings shall not be required to have a minimum thickness equal to the trade size of the fitting.

(4) **Splices and Taps.** Splices and taps shall not be made in fittings intended only for sealing with compound, nor shall other fittings in which splices or taps are made be filled with compound.

(5) **Conductor or Optical Fiber Fill.** The cross-sectional area of the conductors or optical fiber tubes (metallic or nonmetallic) permitted in a seal shall not exceed 25 percent of the cross-sectional area of a rigid metal conduit of the same trade size unless it is specifically listed for a higher percentage of fill.

INTERPRETATION OF ARTICLE 505: CLASS I, ZONE 0, 1, AND 2 LOCATIONS

(E) Drainage.

(1) **Control Equipment.** Where there is a probability that liquid or other condensed vapor may be trapped within enclosures for control equipment or at any point in the raceway system, approved means shall be provided to prevent accumulation or to permit periodic draining of such liquid or condensed vapor.

(2) **Motors and Generators.** Where liquid or condensed vapor may accumulate within motors or generators, joints and conduit systems shall be arranged to minimize entrance of liquid. If means to prevent accumulation or to permit periodic draining are necessary, such means shall be provided at the time of manufacture and shall be considered an integral part of the machine.

505.17 Flexible Cords and Connections.

(A) **Flexible Cords, Class I, Zones 1 and 2.** A flexible cord shall be permitted for connection between portable lighting equipment or other portable utilization equipment and the fixed portion of their supply circuit. Flexible cord shall also be permitted for that portion of the circuit where the fixed wiring methods of 505.15(B) and (C) cannot provide the necessary degree of movement for fixed and mobile electrical utilization equipment in an industrial establishment where conditions of maintenance and engineering supervision ensure that only qualified persons install and service the installation, and where the flexible cord is protected by location or by a suitable guard from damage. The length of the flexible cord shall be continuous. Where flexible cords are used, the cords shall comply with the following:

- (1) Be of a type listed for extra-hard usage
- (2) Contain, in addition to the conductors of the circuit, an equipment grounding conductor complying with 400.23
- (3) Be connected to terminals or to supply conductors in an approved manner
- (4) Be supported by clamps or by other suitable means in such a manner that there will be no tension on the terminal connections
- (5) Be terminated with a listed cord connector that maintains the type of protection where the flexible cord enters boxes, fittings, or enclosures that are required to be explosionproof or flameproof

This Section requires the cord connectors not only be listed but to be listed for the purpose of maintaining the type of protection where the cord connector enters equipment that are required to explosionproof or flameproof.

- (6) Cord entering an increased safety “e” enclosure shall be terminated with a listed increased safety “e” cord connector.

Informational Note: See 400.7 for permitted uses of flexible cords.

Electric submersible pumps with means for removal without entering the wet-pit shall be considered portable utilization equipment. The extension of the flexible cord within a suitable raceway between the wet-pit and the power source shall be permitted.

Electric mixers intended for travel into and out of open-type mixing tanks or vats shall be considered portable utilization equipment.

Informational Note: See 505.18 for flexible cords exposed to liquids having a deleterious effect on the conductor insulation.

(B) Instrumentation Connections for Zone 2. To facilitate replacements, process control instruments shall be permitted to be connected through flexible cords, attachment plugs, and receptacles, provided that all of the following conditions apply:

(1) A switch listed for Zone 2 is provided so that the attachment plug is not depended on to interrupt current, unless the circuit is type “ia,” “ib,” or “ic” protection, in which case the switch is not required.

(2) The current does not exceed 3 amperes at 120 volts, nominal.

(3) The power-supply cord does not exceed 900 mm (3 ft), is of a type listed for extra-hard usage or for hard usage if protected by location, and is supplied through an attachment plug and receptacle of the locking and grounding type.

(4) Only necessary receptacles are provided.

(5) The receptacle carries a label warning against unplugging under load.

This Section was added to address the use of plug and receptacle applications that can be applied to the non-power applications. The requirement provides the rules for process instruments to be readily replaced when required.

505.18 Conductors and Conductor Insulation.

(A) **Conductors.** For type of protection “e,” field wiring conductors shall be copper. Every conductor (including spares) that enters Type “e” equipment shall be terminated at a Type “e” terminal.

Type “e” terminals rely on spacing and protection from loosening, so that sparks or high terminal temperatures are not generated that could cause an explosion; spare unterminated conductors could decrease terminal spacings and possibly cause sparks or increases terminal temperatures to occur. This would not be a problem in a type “d” enclosure, since the enclosure would contain an explosion, but causing sparking or increased terminal temperatures would completely negate the type “e” protection method.

(B) **Conductor Insulation.** Where condensed vapors or liquids may collect on, or come in contact with, the insulation on conductors, such insulation shall be of a type identified for use under such conditions, or the insulation shall be protected by a sheath of lead or by other approved means.

505.19 Uninsulated Exposed Parts. There shall be no uninsulated exposed parts, such as electrical conductors, buses, terminals, or components that operate at more than 30 volts (15 volts in wet locations). These parts shall additionally be protected by type of protection “ia,” “ib,” or “nA” that is suitable for the location.

Intrinsically safe “ia” or “ib” apparatus and nonincendive “nA” equipment operating at no more than 30 volts are permissible. Some types of instrumentation that employ this method of protection, such as pH sensors, have bare live parts that must be in direct contact with the process in order to operate.

505.20 Equipment Requirements.

(A) **Zone 0.** In Class I, Zone 0 locations, only equipment specifically listed and marked as suitable for the location shall be permitted.

Exception: Intrinsically safe apparatus listed for use in Class I, Division 1 locations for the same gas, or as permitted by 505.9(B)(2), and with a suitable temperature class shall be permitted.

INTERPRETATION OF ARTICLE 505: CLASS I, ZONE 0, 1, AND 2 LOCATIONS

(B) Zone 1. In Class I, Zone 1 locations, only equipment specifically listed and marked as suitable for the location shall be permitted.

Exception No. 1: Equipment identified for use in Class I, Division 1 or listed for use in Zone 0 locations for the same gas, or as permitted by 505.9(B)(2), and with a suitable temperature class shall be permitted.

Exception No. 2: Equipment identified for Class I, Zone 1 or Zone 2 type of protection "p" shall be permitted.

(C) Zone 2. In Class I, Zone 2 locations, only equipment specifically listed and marked as suitable for the location shall be permitted.

Exception No. 1: Equipment listed for use in Zone 0 or Zone 1 locations for the same gas, or as permitted by 505.9(B)(2), and with a suitable temperature class, shall be permitted.

Exception No. 2: Equipment identified for Class I, Zone 1 or Zone 2 type of protection "p" shall be permitted.

Exception No. 3: Equipment identified for use in Class I, Division 1 or Division 2 locations for the same gas, or as permitted by 505.9(B)(2), and with a suitable temperature class shall be permitted.

Exception No. 4: In Class I, Zone 2 locations, the installation of open or nonexplosionproof or nonflameproof enclosed motors, such as squirrel-cage induction motors without brushes, switching mechanisms, or similar arc-producing devices that are not identified for use in a Class I, Zone 2 location shall be permitted.

Informational Note No. 1: It is important to consider the temperature of internal and external surfaces that may be exposed to the flammable atmosphere.

Informational Note No. 2: It is important to consider the risk of ignition due to currents arcing across discontinuities and overheating of parts in multisection enclosures of large motors and generators. Such motors and generators may need equipotential bonding jumpers across joints in the enclosure and from enclosure to ground. Where the presence of ignitable gases or vapors is suspected, clean air purging may be needed immediately prior to and during start-up periods.

Informational Note No. 3: For further information on the application of electric motors in Class I, Zone 2 hazardous (classified) locations, see IEEE 1349-2011, *IEEE Guide for the Application of Electric Motors in Class I, Division 2 and Class I, Zone 2 Hazardous (Classified) Locations*.

(D) Materials. Equipment marked Group IIC shall be permitted for applications requiring Group IIA or Group IIB equipment. Similarly, equipment marked Group IIB shall be permitted for applications requiring Group IIA equipment.

Equipment marked for a specific gas or vapor shall be permitted for applications where the specific gas or vapor may be encountered.

Informational Note: One common example combines these markings with equipment marked IIB +H₂. This equipment is suitable for applications requiring Group IIA equipment, Group IIB equipment, or equipment for hydrogen atmospheres.

Section 505.20(D) clarifies that IIC equipment is suitable for applications requiring IIA or IIB equipment. Similarly, it clarifies that IIB equipment is suitable for applications requiring IIA equipment. This correlates with the marking requirements in the product standards.

(E) Manufacturer's Instructions. Electrical equipment installed in hazardous (classified) locations shall be installed in accordance with the instructions (if any) provided by the manufacturer.

505.22 Increased Safety "e" Motors and Generators. In Class I, Zone 1 locations, Increased Safety "e" motors and generators of all voltage ratings shall be listed for Zone 1 locations, and shall comply with all of the following:

(1) Motors shall be marked with the current ratio, I_A/I_N , and time, t_E .

(2) Motors shall have controllers marked with the model or identification number, output rating (horsepower or kilowatt), full-load amperes, starting current ratio (IA/IN), and time (tE) of the motors that they are intended to protect; the controller marking shall also include the specific overload protection type (and setting, if applicable) that is listed with the motor or generator.

(3) Connections shall be made with the specific terminals listed with the motor or generator.

(4) Terminal housings shall be permitted to be of substantial, nonmetallic, nonburning material, provided an internal grounding means between the motor frame and the equipment grounding connection is incorporated within the housing.

(5) The provisions of Part III of Article 430 shall apply regardless of the voltage rating of the motor.

(6) The motors shall be protected against overload by a separate overload device that is responsive to motor current. This device shall be selected to trip or shall be rated in accordance with the listing of the motor and its overload protection.

(7) Sections 430.32(C) and 430.44 shall not apply to such motors.

(8) The motor overload protection shall not be shunted or cut out during the starting period.

Since type "e" motors and generators are designed to not cause an explosion, and do not rely on their enclosures to contain explosions like type "d" equipment, the hottest temperature that occurs anywhere in the motor or generator needs to be measured and marked, not just the outside surface temperature. Overload protection devices are required to keep these internal temperatures from exceeding those determined during the testing process.

Informational Note: Reciprocating engine-driven generators, compressors, and other equipment installed in Class I, Zone 2 locations may present a risk of ignition of flammable materials associated with fuel, starting, compression, and so forth, due to inadvertent release or equipment malfunction by the engine ignition system and controls. For further information on the requirements for ignition systems for reciprocating engines installed in Class I, Zone 2 hazardous (classified) locations, see ANSI/ISA-12.20.01-2009, *General Requirements for Electrical Ignition Systems for Internal Combustion Engines in Class I, Division 2 or Zone 2, Hazardous (Classified) Locations*.

The new Information Note references the product standard for electrical ignition systems for engines that may become a source of ignition in a classified location. The standard employs Class I, Zone 2 protection techniques utilizing non-shielded technology for ignition systems in these applications.

505.25 Grounding and Bonding. Regardless of the voltage of the electrical system, grounding and bonding shall comply with Article 250 and the requirements in 505.25(A) and (B).

(A) Bonding. The locknut-bushing and double-locknut types of contacts shall not be depended on for bonding purposes, but bonding jumpers with proper fittings or other approved means of bonding shall be used. Such means of bonding shall apply to all intervening raceways,

INTERPRETATION OF ARTICLE 505: CLASS I, ZONE 0, 1, AND 2 LOCATIONS

fittings, boxes, enclosures, and so forth, between Class I locations and the point of grounding for service equipment or point of grounding of a separately derived system.

Exception: The specific bonding means shall be required only to the nearest point where the grounded circuit conductor and the grounding electrode are connected together on the line side of the building or structure disconnecting means as specified in 250.32(B), provided the branchcircuit overcurrent protection is located on the load side of the disconnecting means.

(B) Types of Equipment Grounding Conductors. Flexible metal conduit and liquidtight flexible metal conduit shall include an equipment bonding jumper of the wire type in compliance with 250.102.

Exception: In Class I, Zone 2 locations, the bonding jumper shall be permitted to be deleted where all of the following conditions are met:

- (a) Listed liquidtight flexible metal conduit 1.8 m (6 ft) or less in length, with fittings listed for grounding, is used.*
- (b) Overcurrent protection in the circuit is limited to 10 amperes or less.*
- (c) The load is not a power utilization load.*

505.26 Process Sealing. This section shall apply to process-connected equipment, which includes, but is not limited to, canned pumps, submersible pumps, flow, pressure, temperature, or analysis measurement instruments. A process seal is a device to prevent the migration of process fluids from the designed containment into the external electrical system. Process connected electrical equipment that incorporates a single process seal, such as a single compression seal, diaphragm, or tube to prevent flammable or combustible fluids from entering a conduit or cable system capable of transmitting fluids, shall be provided with an additional means to mitigate a single process seal failure. The additional means may include, but is not limited to the following:

- (1) A suitable barrier meeting the process temperature and pressure conditions that the barrier is subjected to upon failure of the single process seal. There shall be a vent or drain between the single process seal and the suitable barrier. Indication of the single process seal failure shall be provided by visible leakage, an audible whistle, or other means of monitoring.
- (2) A listed Type MI cable assembly, rated at not less than 125 percent of the process pressure and not less than 125 percent of the maximum process temperature (in degrees Celsius), installed between the cable or conduit and the single process seal.
- (3) A drain or vent located between the single process seal and a conduit or cable seal. The drain or vent shall be sufficiently sized to prevent overpressuring the conduit or cable seal above 6 in. water column (1493 Pa). Indication of the single process seal failure shall be provided by visible leakage, an audible whistle, or other means of monitoring.
- (4) An add-on secondary seal marked “secondary seal” and rated for the pressure and temperature conditions to which it will be subjected upon failure of the single process seal.

This Subsection was included to address the secondary seal method that is now covered in the product standard ANSI/ISA-12.27.01.

Process-connected electrical equipment that does not rely on a single process seal or is listed and marked “single seal” or “dual seal” shall not

be required to be provided with an additional means of sealing.

Informational Note: For construction and testing requirements for process sealing for listed and marked single seal, dual seal, or secondary seal equipment, refer to ANSI/ISA-12.27.01-2011, *Requirements for Process Sealing Between Electrical Systems and Flammable or Combustible Process Fluids*.

NOTES:

INTERPRETATION OF ARTICLE 506: ZONE 20, 21, AND 22 LOCATIONS FOR COMBUSTIBLE DUSTS OR IGNITABLE FIBERS/FLYINGS

CHANGES TO ARTICLE 506

The following Article 506 sections have been revised during the 2014 *NEC*® Code cycle. These changes are those that are substantive and should be noted. This list does not include those changes that are editorial in nature.

Underlined text indicates a section that has been revised from the previous *NEC*® edition. It is not intended to indicate legislation text detailing the word-for-word revisions to the section. Where minor revisions have been made to a section, these will include underlined text for select words to indicate the minor revision.

- **Section 506.2**
Definitions. Combustible Dust
- **Section 506.3**
Other Articles
- **Section 506.6**
Material Groups
- **Section 506.9(C)(1)**
Equipment Requirements. Marking. Division Equipment
- **Section 506.9(C)(2)**
Equipment Requirements. Marking. Zone Equipment
- **Section 506.9(D)**
Equipment Requirements. Temperature Classification
Table 506.9(C)(2)(3)
Types of Protection Designation
- **Section 506.15(A)(6) Exception No. 2**
Wiring Methods. Zone 20. Flexible Connections. Elevator Cable
- **Section 506.15(A)(7)**
Wiring Methods. Zone 20. Optical Fiber Cable
- **Section 506.15(C)(6)**
Wiring Methods. Zone 22. Type TC-ER Cable
- **Section 506.15(C)(9)**
Wiring Methods. Zone 22. Optical Fiber Cable
- **Section 506.20(D)**
Equipment Installation. Material Group

Informational Note: Text that is followed by a reference in brackets has been extracted from NFPA 499-2013, *Recommended Practice for the Classification of Combustible Dusts and of Hazardous (Classified) Locations for Electrical Installation in Chemical Process Areas*. Only editorial changes were made to the extracted text to make it consistent with this *Code*.

506.1 Scope. This article covers the requirements for the zone classification system as an alternative to the division classification system covered in Article 500, Article 502, and Article 503 for electrical and electronic equipment and wiring for all voltages in Zone 20, Zone 21,

and Zone 22 hazardous (classified) locations where fire and explosion hazards may exist due to combustible dusts or ignitable fibers/flyings.

Informational Note No. 1: For the requirements for electrical and electronic equipment and wiring for all voltages in Class I, Division 1 or Division 2; Class II, Division 1 or Division 2; Class III, Division 1 or Division 2; and Class I, Zone 0 or Zone 1 or Zone 2 hazardous (classified) locations where fire or explosion hazards may exist due to flammable gases or vapors, flammable liquids, or combustible dusts or fibers, refer to Articles 500 through 505.

Informational Note No. 2: Zone 20, Zone 21, and Zone 22 area classifications are based on the modified IEC area classification system as defined in ANSI/ISA-61241-10 (12.10.05)-2004, *Electrical Apparatus for Use in Zone 20, Zone 21, and Zone 22 Hazardous (Classified) Locations — Classification of Zone 20, Zone 21, and Zone 22 Hazardous (Classified) Locations*.

Informational Note No. 3: The unique hazards associated with explosives, pyrotechnics, and blasting agents are not addressed in this article.

Article 506 addresses the Zone system for combustible dust, fibers and flyings. Like the Zone system for flammable gas, the Zone dust classification has three Zones (Zone 20, Zone 21, and Zone 22), and is the primary system used for combustible dust hazardous locations outside North America. More information on how the dust Zones are classified can be found in ANSI/ISA 61241-10 (12.10.05), "Electrical Apparatus for Use in Zone 20, Zone 21, and Zone 22 Hazardous (Classified) Locations — Classification of Zone 20, Zone 21, and Zone 22 Hazardous (Classified) Locations."

Combustible metallic dusts are now incorporated into the scope of Article 506. The primary purpose of Article 506 is to allow installations using Zone based area classifications for combustible dust. Article 506 also provides a cross reference to the Class II and Class III protection techniques allowed in Articles 502 and 503, and how equipment using those Class II and III, Division 1 and Division 2 based techniques can be safely installed and used in Zone 20, 21, and 22 hazardous locations.

506.2 Definitions. For purposes of this article, the following definitions apply. Associated Nonincendive Field Wiring Apparatus. Apparatus in which the circuits are not necessarily nonincendive themselves but that affect the energy in nonincendive field wiring circuits and are relied upon to maintain nonincendive energy levels. Such apparatus are one of the following:

(1) Electrical apparatus that has an alternative type of protection for use in the appropriate hazardous (classified) location

(2) Electrical apparatus not so protected that shall not be used in a hazardous (classified) location Informational Note: Associated nonincendive field wiring apparatus has designated associated nonincendive field wiring apparatus connections for nonincendive field wiring apparatus and may also have connections for other electrical apparatus.

Combustible Dust. Dust particles that are 500 microns or smaller (material passing a U.S. No. 35 Standard Sieve as defined in ASTM E 11-09, Standard Specification for Wire Cloth and Sieves for Testing Purposes) and present a fire or explosion hazard when dispersed and ignited in air.

Informational Note: See ASTM E 1226-12a, *Standard Test Method for Explosibility of Dust Clouds*, or ISO 6184-1, *Explosion protection systems — Part 1: Determination of explosion indices of combustible dusts in air, for procedures for determining the explosibility of dusts.*

The term Combustible Dust is contained in a number of NFPA standards where these definitions may not be identical therefore the

INTERPRETATION OF ARTICLE 506: ZONE 20, 21, AND 22 LOCATIONS FOR COMBUSTIBLE DUSTS OR IGNITABLE FIBERS/FLYINGS

definition as intended by the NFPA 70 Code Panel 14 was added to the *NEC*. This was also added to ensure correlation between the NFPA classification standard for dust (NFPA 499) and the *NEC*. This Section was revised to define the size of the dust particles as 500 microns or smaller. The size had been defined as 420 microns or smaller. This was necessary to correlate with NFPA 499 which was also revised to change the size of the dust particles.

Dust-Ignitionproof. Equipment enclosed in a manner that excludes dusts and does not permit arcs, sparks, or heat otherwise generated or liberated inside of the enclosure to cause ignition of exterior accumulations or atmospheric suspensions of a specified dust on or in the vicinity of the enclosure.

Informational Note: For further information on dustignitionproof enclosures, see Type 9 enclosure in ANSI/NEMA 250-2008, *Enclosures for Electrical Equipment*, and ANSI/UL 1203-2009, *Explosionproof and Dust-Ignitionproof Electrical Equipment for Hazardous (Classified) Locations*.

The Information Note makes reference to Type 9 enclosures in ANSI/NEMA-250, however equipment that is marked only as Type 9 do not indicate what Dust Material Groups the equipment is suitable for use in. ANSI/UL 1203 does require the full classification marking on the listed equipment, to include the Class, Material Group, Zone, and Temperature Classification, if required.

Dusttight. Enclosures constructed so that dust will not enter under specified test conditions.

Informational Note: See ANSI/ISA-12.12.01-2012, *Nonincendive Electrical Equipment for Use in Class I and II, Division 2, and Class III, Divisions 1 and 2 Hazardous (Classified) Locations*.

Nonincendive Circuit. A circuit, other than field wiring, in which any arc or thermal effect produced under intended operating conditions of the equipment is not capable, under specified test conditions, of igniting the flammable gas-air, vapor-air, or dust-air mixture.

Informational Note: Conditions are described in ANSI/ISA-12.12.01-2012, *Nonincendive Electrical Equipment for Use in Class I and II, Division 2, and Class III, Divisions 1 and 2 Hazardous (Classified) Locations*.

Nonincendive Equipment. Equipment having electrical/electronic circuitry that is incapable, under normal operating conditions, of causing ignition of a specified flammable gas-air, vapor-air, or dust-air mixture due to arcing or thermal means.

Informational Note: For further information, see ANSI/ISA-12.12.01-2012, *Nonincendive Electrical Equipment for Use in Class I and II, Division 2, and Class III, Divisions 1 and 2 Hazardous (Classified) Locations*.

Nonincendive Field Wiring. Wiring that enters or leaves an equipment enclosure and, under normal operating conditions of the equipment, is not capable, due to arcing or thermal effects, of igniting the flammable gas-air, vapor-air, or dust-air mixture. Normal operation includes opening, shorting, or grounding the field wiring.

Nonincendive Field Wiring Apparatus. Apparatus intended to be connected to nonincendive field wiring.

Informational Note: For further information, see ANSI/ISA-12.12.01-2012, *Nonincendive Electrical Equipment for Use in Class I and II, Division 2, and Class III, Divisions 1 and 2 Hazardous (Classified) Locations*.

Pressurized. The process of supplying an enclosure with a protective gas with or without continuous flow, at sufficient pressure to prevent the

entrance of combustible dust or ignitable fibers/flyings.

Informational Note: Informational Note: For further information, see ANSI/NFPA 496-2013, *Standard for Purged and Pressurized Enclosures for Electrical Equipment*.

Protection by Encapsulation “m.” Type of protection where electrical parts that could cause ignition of a mixture of combustible dust or fibers/flyings in air are protected by enclosing them in a compound in such a way that the explosive atmosphere cannot be ignited.

Informational Note No. 1: For additional information, see ANSI/ISA-60079-18 (12.23.01)-2009, *Explosive atmospheres — Part 18: Equipment protection by encapsulation “m”*; ANSI/UL 60079-18-2009, *Explosive atmospheres — Part 18: Equipment protection by encapsulation “m”*; and ANSI/ISA-61241-18 (12.10.07)-2011, *Electrical Apparatus for Use in Zone 20, Zone 21 and Zone 22 Hazardous (Classified) Locations — Protection by Encapsulation “m.”*

Informational Note No. 2: Encapsulation is designated level of protection “maD” or “ma” for use in Zone 20 locations. Encapsulation is designated level of protection “mbD” or “mb” for use in Zone 21 locations. Encapsulation is designated type of protection “mc” for use in Zone 22 locations.

ANSI/ISA-60079-18 (12.23.01) and ANSI/UL 60079-18 now include three levels of protection by Encapsulation for explosive dust atmospheres.

Protection by Enclosure “t.” Type of protection for explosive dust atmospheres where electrical apparatus is provided with an enclosure providing dust ingress protection and a means to limit surface temperatures.

Informational Note No. 1: For additional information, see ANSI/ISA-60079-31 (12.10.03)-2009, *Explosive Atmospheres — Part 31: Equipment Dust Ignition Protection by Enclosure “t”*; and ANSI/ISA-61241-1 (12.10.03)-2011, *Electrical Apparatus for Use in Zone 21 and Zone 22 Hazardous (Classified) Locations — Protection by Enclosure “t.”*

Informational Note No. 2: Protection by enclosure is designated level of protection “ta” for use in Zone 20 locations. Protection by enclosure is designated level of protection “tb” or “td” for use in Zone 21 locations. Protection by enclosure is designated level of protection “tc” or “td” for use in Zone 22 locations.

The referenced product standards now include three levels of protection by Enclosure for explosive dust atmospheres.

Protection by Intrinsic Safety “iD.” Type of protection where any spark or thermal effect is incapable of causing ignition of a mixture of combustible dust, fibers, or flyings in air under prescribed test conditions.

Informational Note No. 1: For additional information, see ANSI/ISA-60079-11 (12.01.01)-2011, *Electrical Apparatus for Explosive Gas Atmospheres — Part 11: intrinsic safety “i”*; ANSI/UL 60079-11-2011, *Electrical Apparatus for Explosive Gas Atmospheres — Part 11: Intrinsic safety “i”*; and ANSI/ISA-61241-11 (12.10.04)-2011, *Electrical Apparatus for Use in Zone 20, Zone 21 and Zone 22 Hazardous (Classified) Locations — Protection by Intrinsic Safety “i.”*

Informational Note No. 2: Intrinsic safety is designated level of protection “iaD” or “ia” for use in Zone 20 locations. Intrinsic safety is designated level of protection “ibD” or “ib” for use in Zone 21 locations. Intrinsic safety is designated type of protection “ic” for use in Zone 22 locations.

The new edition of ISA 60079-11 (12.02.01) now includes the requirements for intrinsically safe equipment for explosive dust atmospheres.

Protection by Pressurization “pD.” Type of protection that guards

INTERPRETATION OF ARTICLE 506: ZONE 20, 21, AND 22 LOCATIONS FOR COMBUSTIBLE DUSTS OR IGNITIBLE FIBERS/FLYINGS

against the ingress of a mixture of combustible dust or fibers/flyings in air into an enclosure containing electrical equipment by providing and maintaining a protective gas atmosphere inside the enclosure at a pressure above that of the external atmosphere.

Informational Note: For additional information, see ANSI/ISA-61241-2 (12.10.06)-2006, *Electrical Apparatus for Use in Zone 21 and Zone 22 Hazardous (Classified) Locations — Protection by Pressurization “pD.”*

The Zone dust classification system divides hazardous locations into three Zones, in a system parallel to the Zone flammable gas system described in Article 505.

Zone 20 Hazardous (Classified) Location. An area where combustible dust or ignitable fibers/flyings are present continuously or for long periods of time in quantities sufficient to be hazardous, as classified by 506.5(B)(1).

Zone 21 Hazardous (Classified) Location. An area where combustible dust or ignitable fibers/flyings are likely to exist occasionally under normal operation in quantities sufficient to be hazardous, as classified by 506.5(B)(2).

Zone 20 and Zone 21 together are the equivalent to Class II, Division 1 and Class III, Division 1, with Zone 20 locations representing the highest level of combustible dust hazard present.

Zone 22 Hazardous (Classified) Location. An area where combustible dust or ignitable fibers/flyings are not likely to occur under normal operation in quantities sufficient to be hazardous, as classified by 506.5(B)(3).

Zone 22 is equivalent to Class II, Division 2 and Class III, Division 2.

506.3 Other Articles. All other applicable rules contained in this Code shall apply to electrical equipment and wiring installed in hazardous (classified) locations.

Exception: As modified by Article 504 and this article.

This Section ties in the requirements that are contained in the General Sections of the Code. It had been missing from previous editions of the NEC®. This is important for proper use of the Code.

506.4 General.

(A) Documentation for Industrial Occupancies. Areas designated as hazardous (classified) locations shall be properly documented. This documentation shall be available to those authorized to design, install, inspect, maintain, or operate electrical equipment.

(B) Reference Standards. Important information relating to topics covered in Chapter 5 are found in other publications.

Informational Note: It is important that the authority having jurisdiction be familiar with the recorded industrial experience as well as with standards of the National Fire Protection Association (NFPA), the International Society of Automation (ISA), and the International Electrotechnical Commission (IEC) that may be of use in the classification of various locations, the determination of adequate ventilation, and the protection against static electricity and lightning hazards.

506.5 Classification of Locations.

(A) Classifications of Locations. Locations shall be classified on the basis of the properties of the combustible dust or ignitable fibers/

flyings that may be present, and the likelihood that a combustible or combustible concentration or quantity is present. Each room, section, or area shall be considered individually in determining its classification. Where pyrophoric materials are the only materials used or handled, these locations are outside of the scope of this article.

(B) Zone 20, Zone 21, and Zone 22 Locations. Zone 20, Zone 21, and Zone 22 locations are those in which combustible dust or ignitable fibers/flyings are or may be present in the air or in layers, in quantities sufficient to produce explosive or ignitable mixtures. Zone 20, Zone 21, and Zone 22 locations shall include those specified in 506.5(B)(1), (B)(2), and (B)(3).

Informational Note: Through the exercise of ingenuity in the layout of electrical installations for hazardous (classified) locations, it is frequently possible to locate much of the equipment in a reduced level of classification and, thus, to reduce the amount of special equipment required.

(1) Zone 20. A Zone 20 location is a location in which

(a) Ignitable concentrations of combustible dust or ignitable fibers/flyings are present continuously.

(b) Ignitable concentrations of combustible dust or ignitable fibers/flyings are present for long periods of time.

Informational Note No. 1: As a guide to classification of Zone 20 locations, refer to ANSI/ISA-61241-10 (12.10.05)-2004, *Electrical Apparatus for Use in Zone 20, Zone 21, and Zone 22 Hazardous (Classified) Locations — Classification of Zone 20, Zone 21, and Zone 22 Hazardous (Classified) Locations.*

Informational Note No. 2: Zone 20 classification includes locations inside dust containment systems; hoppers, silos, etc., cyclones and filters, dust transport systems, except some parts of belt and chain conveyors, etc.; blenders, mills, dryers, bagging equipment, etc.

(2) Zone 21. A Zone 21 location is a location

(a) In which ignitable concentrations of combustible dust or ignitable fibers/flyings are likely to exist occasionally under normal operating conditions; or

(b) In which ignitable concentrations of combustible dust or ignitable fibers/flyings may exist frequently because of repair or maintenance operations or because of leakage; or

(c) In which equipment is operated or processes are carried on, of such a nature that equipment breakdown or faulty operations could result in the release of ignitable concentrations of combustible dust or ignitable fibers/flyings and also cause simultaneous failure of electrical equipment in a mode to cause the electrical equipment to become a source of ignition; or

(d) That is adjacent to a Zone 20 location from which ignitable concentrations of dust or ignitable fibers/flyings could be communicated, unless communication is prevented by adequate positive pressure ventilation from a source of clean air and effective safeguards against ventilation failure are provided.

Informational Note No. 1: As a guide to classification of Zone 21 locations, refer to ANSI/ISA-61241-10 (12.10.05)-2004, *Electrical Apparatus for Use in Zone 20, Zone 21, and Zone 22 Hazardous (Classified) Locations — Classification of Zone 20, Zone 21, and Zone 22 Hazardous (Classified) Locations.*

Informational Note No. 2: This classification usually includes locations outside dust containment and in the immediate vicinity of access doors subject to frequent removal or

INTERPRETATION OF ARTICLE 506: ZONE 20, 21, AND 22 LOCATIONS FOR COMBUSTIBLE DUSTS OR IGNITABLE FIBERS/FLYINGS

opening for operation purposes when internal combustible mixtures are present; locations outside dust containment in the proximity of filling and emptying points, feed belts, sampling points, truck dump stations, belt dump over points, etc. where no measures are employed to prevent the formation of combustible mixtures; locations outside dust containment where dust accumulates and where due to process operations the dust layer is likely to be disturbed and form combustible mixtures; locations inside dust containment where explosive dust clouds are likely to occur (but neither continuously, nor for long periods, nor frequently) as, for example, silos (if filled and/or emptied only occasionally) and the dirty side of filters if large self-cleaning intervals are occurring.

(3) Zone 22. A Zone 22 location is a location

(a) In which ignitable concentrations of combustible dust or ignitable fibers/flyings are not likely to occur in normal operation and, if they do occur, will only persist for a short period; or

(b) In which combustible dust or fibers/flyings are handled, processed, or used but in which the dust or fibers/flyings are normally confined within closed containers or closed systems from which they can escape only as a result of the abnormal operation of the equipment with which the dust or fibers/flyings are handled, processed, or used; or

(c) That is adjacent to a Zone 21 location, from which ignitable concentrations of dust or fibers/flyings could be communicated, unless such communication is prevented by adequate positive pressure ventilation from a source of clean air and effective safeguards against ventilation failure are provided.

*Informational Note No. 1: As a guide to classification of Zone 22 locations, refer to ANSI/ISA-61241-10 (12.10.05)-2004, *Electrical Apparatus for Use in Zone 20, Zone 21, and Zone 22 Hazardous (Classified) Locations — Classification of Zone 20, Zone 21, and Zone 22 Hazardous (Classified) Locations*.*

Informational Note No. 2: Zone 22 locations usually include outlets from bag filter vents, because in the event of a malfunction there can be emission of combustible mixtures; locations near equipment that has to be opened at infrequent intervals or equipment that from experience can easily form leaks where, due to pressure above atmospheric, dust will blow out; pneumatic equipment, flexible connections that can become damaged, etc.; storage locations for bags containing dusty product, since failure of bags can occur during handling, causing dust leakage; and locations where controllable dust layers are formed that are likely to be raised into explosive dust-air mixtures. Only if the layer is removed by cleaning before hazardous dust-air mixtures can be formed is the area designated unclassified.

Informational Note No. 3: Locations that normally are classified as Zone 21 can fall into Zone 22 when measures are employed to prevent the formation of explosive dust-air mixtures. Such measures include exhaust ventilation. The measures should be used in the vicinity of (bag) filling and emptying points, feed belts, sampling points, truck dump stations, belt dump over points, etc.

The dust zones are classified using the same philosophy as for the gas zones. The dust Zone 20 is where a hazard is present much of the time in normal operation, Zone 21 is where the hazard is present at least part of the time, and Zone 22 is where the dust hazard exists only during abnormal operation or leaks.

506.6 Material Groups. For the purposes of testing, approval, and area classification, various air mixtures (not oxygen enriched) shall be grouped as required in 506.6(A), (B), and (C).

(A) Group IIIC. Combustible metal dust. *Informational Note: Group IIIC is equivalent to Class II, Group E as described in 500.6(B)(1).*

(B) Group IIIB. Combustible dust other than combustible metal dust.

Informational Note: Group IIIB is equivalent to Class II, Groups F and G as described in 500.6(B)(2) and 500.6(B)(3), respectively.

(C) Group IIIA. Solid particles, including fibers, greater than 500 μm in nominal size, which may be suspended in air and could settle out of the atmosphere under their own weight.

Informational Note No. 1: Group IIIA is equivalent to Class III.

Informational Note No. 2: Examples of flyings include rayon, cotton (including cotton linters and cotton waste), sisal, jute, hemp, cocoa fiber, oakum, and baled waste kapok.

Product standards include a marking of the dust group. Article 506 now defines the dust groups to better ensure proper selection of the equipment.

506.7 Special Precaution. Article 506 requires equipment construction and installation that ensures safe performance under conditions of proper use and maintenance.

Informational Note: It is important that inspection authorities and users exercise more than ordinary care with regard to the installation and maintenance of electrical equipment in hazardous (classified) locations.

(A) Implementation of Zone Classification System. Classification of areas, engineering and design, selection of equipment and wiring methods, installation, and inspection shall be performed by qualified persons.

Zone dust installations require the use of qualified personnel. Those individuals who are qualified to perform Class II installations should not have any trouble with the Zone system, since at the moment, no new methods of protection or wiring methods have been introduced, only the area classification system is different.

(B) Dual Classification. In instances of areas within the same facility classified separately, Zone 22 locations shall be permitted to abut, but not overlap, Class II or Class III, Division 2 locations. Zone 20 or Zone 21 locations shall not abut Class II or Class III, Division 1 or Division 2 locations.

(C) Reclassification Permitted. A Class II or Class III, Division 1 or Division 2 location shall be permitted to be reclassified as a Zone 20, Zone 21, or Zone 22 location, provided that all of the space that is classified because of a single combustible dust or ignitable fiber/flying source is reclassified under the requirements of this article.

The reclassification and dual classification rules parallel those applied to Zone flammable gas locations.

(D) Simultaneous Presence of Flammable Gases and Combustible Dusts or Fibers/Flyings. Where flammable gases, combustible dusts, or fibers/flyings are or may be present at the same time, the simultaneous presence shall be considered during the selection and installation of the electrical equipment and the wiring methods, including the determination of the safe operating temperature of the electrical equipment.

As with Class II installations, care must be taken when flammable gas and combustible dust are present at the same time. The temperature rating is usually more critical for dust than gas, and the equipment temperature can go higher, since dust can have an insulating effect on heat dissipation. This is especially true with high heat producing equipment like luminaires, where dust can both insulate radiated heat and absorb radiated light energy so as to produce heat.

506.8 Protection Techniques. Acceptable protection techniques for electrical and electronic equipment in hazardous (classified) locations

INTERPRETATION OF ARTICLE 506: ZONE 20, 21, AND 22 LOCATIONS FOR COMBUSTIBLE DUSTS OR IGNITABLE FIBERS/FLYINGS

shall be as described in 506.8(A) through (J).

(A) Dust Ignitionproof. This protection technique shall be permitted for equipment in Zone 20, Zone 21, and Zone 22 locations for which it is identified.

Dust Ignitionproof protection is acceptable for Class II, Division 1, and therefore is acceptable for any Zone location. The construction and testing requirements for Class II, Division 1 Dust Ignitionproof enclosures, for now, exceed those required in the parallel IEC standards. These differences will have to be identified and exceptions taken in the U.S. version of the IEC standard before it can be put into general use for U.S. installations.

(B) Pressurized. This protection technique shall be permitted for equipment in Zone 21 and Zone 22 locations for which it is identified.

Pressurization to Class I, Division 1 or Zone 1 standards are acceptable for Zone 21, and pressurization to Class I, Division 2 and Zone 2 standards are acceptable for Zone 22, since the process of pressurizing an enclosure keeps flammable gas and dust out of the enclosure.

(C) Intrinsic Safety. This protection technique shall be permitted for equipment in Zone 20, Zone 21, and Zone 22 locations for which it is identified.

Intrinsic safety for Divisions or Zones will almost always be acceptable for combustible dust, since the ignition energy of dusts is usually above the ignition energies of all the gases. Very fine dust and some of the new “nanodusts” may be an exception to this, but very little data is available at this time on these substances. Dust ingress can cause operational problems with intrinsically safe equipment that is not designed to exclude dust from entering the enclosure, and in particular, metallic dust can cause severe problems with intrinsically safe equipment. Intrinsic safety works in part by maintaining certain spacing between different parts of the circuit, and conductive metal dust can violate these spacings. Metal dusts are outside the scope of Article 506.

(D) Dusttight. This protection technique shall be permitted for equipment in Zone 22 locations for which it is identified.

Dusttight protection is suitable for Class II, Division 2, and therefore is also suitable for Zone 22.

(E) Protection by Encapsulation “m”. This protection technique shall be permitted for equipment in Zone 20, Zone 21, and Zone 22 locations for which it is identified.

Informational Note: See Table 506.9(C)(2)(3) for the descriptions of subdivisions for encapsulation.

(F) Nonincendive Equipment. This protection technique shall be permitted for equipment in Zone 22 locations for which it is identified.

Nonincendive circuits also work in dust environments for the same reason that intrinsically safe circuits do. The ignition energy available from equipment certified for gas atmospheres is not sufficient to ignite combustible dust atmospheres. As with intrinsically safe equipment, care should be taken with equipment that will not exclude dust from the equipment enclosure, making sure the ingress of dust will not adversely affect equipment operation.

(G) Protection by Enclosure “t”. This protection technique shall be permitted for equipment in Zone 20, Zone 21, and Zone 22 locations for which it is identified.

Informational Note: See Table 506.9(C)(2)(3) for the descriptions of subdivisions for protection by enclosure “t.”

(H) Protection by Pressurization “pD”. This protection technique shall be permitted for equipment in Zone 21 and Zone 22 locations for which it is identified.

(I) Protection by Intrinsic Safety “iD”. This protection technique shall be permitted for equipment in Zone 20, Zone 21, and Zone 22 locations for which it is listed.

506.9 Equipment Requirements.

(A) Suitability. Suitability of identified equipment shall be determined by one of the following:

- (1) Equipment listing or labeling
- (2) Evidence of equipment evaluation from a qualified testing laboratory or inspection agency concerned with product evaluation
- (3) Evidence acceptable to the authority having jurisdiction such as a manufacturer’s self-evaluation or an owner’s engineering judgment

Informational Note: Additional documentation for equipment may include certificates demonstrating compliance with applicable equipment standards, indicating special conditions of use, and other pertinent information.

(B) Listing.

- (1) Equipment that is listed for Zone 20 shall be permitted in a Zone 21 or Zone 22 location of the same dust or ignitable fiber/flying. Equipment that is listed for Zone 21 may be used in a Zone 22 location of the same dust fiber/flying.
- (2) Equipment shall be permitted to be listed for a specific dust or ignitable fiber/flying or any specific combination of dusts fibers/flyings.

(C) Marking.

(1) Division Equipment. Equipment identified for Class II, Division 1 or Class II, Division 2 shall, in addition to being marked in accordance with 500.8(C), be permitted to be marked with all of the following:

- (1) Zone 20, 21, or 22 (as applicable)
- (2) Material group in accordance with 506.6
- (3) Maximum surface temperature in accordance with 506.9(D), marked as a temperature value in degrees C, preceded by “T” and followed by the symbol “°C”

Marking for material group has been added to better ensure proper selection of equipment.

(2) Zone Equipment. Equipment meeting one or more of the protection techniques described in 506.8 shall be marked with the following in the order shown:

- (1) Zone
- (2) Symbol “AEx”
- (3) Protection technique(s) in accordance with Table 506.9(C)(2)(3)

INTERPRETATION OF ARTICLE 506: ZONE 20, 21, AND 22 LOCATIONS FOR COMBUSTIBLE DUSTS OR IGNITABLE FIBERS/FLYINGS

(4) [Material group in accordance with 506.6](#)

(5) [Maximum surface temperature in accordance with 506.9\(D\)](#), marked as a temperature value in degrees C, preceded by “T” and followed by the symbol “°C”

(6) [Ambient temperature marking in accordance with 506.9\(D\)](#)

Marking for material group has been added to better ensure proper selection of equipment.

Informational Note: The EPL (or equipment protection level) may appear in the product marking. EPLs are designated as G for gas, D for dust, or M for mining, and are then followed by a letter (a, b, or c) to give the user a better understanding as to whether the equipment provides either (a) a “very high,” (b) “high,” or (c) an “enhanced” level of protection against ignition of an explosive atmosphere. For example, an AEx pb IIIB T165°C motor (which is suitable by protection concept for application in Zone 21) may additionally be marked with an EPL of “Db”, AEx p IIIB T165°C Db.

This informational note identifies the product standards that provide for the EPL marking. This is to help the user make better decisions on what type of equipment for a given protection technique is needed for their application. Refer to ANSI/UL 60079-31-2009 for more detailed information.

Exception: Associated apparatus NOT suitable for installation in a hazardous (classified) location shall be required to be marked only with 506.9(C)(2)(2), (3), and (5), but BOTH the symbol AEx in 506.9(C)(2)(2) and the symbol for the type of protection in 506.9(C)(2)(3) shall be enclosed within the same square brackets; for example, [AEx iaD] or [AEx ia] IIIC.

The material group and ambient temperature limitations are not required to be marked for associated apparatus.

(D) Temperature Classifications. Equipment shall be marked to show the [maximum surface temperature referenced to a 40°C ambient, or at the higher marked ambient temperature if the equipment is rated and marked for an ambient temperature of greater than 40°C. For equipment installed in a Zone 20 or Zone 21 location, the operating temperature shall be based on operation of the equipment when blanketed with the maximum amount of dust \(or with dust-simulating fibers/flyings\) that can accumulate on the equipment.](#) Electrical equipment designed for use in the ambient temperature range between -20°C and +40°C shall require no additional ambient temperature marking. Electrical equipment that is designed for use in a range of ambient temperatures other than -20°C and +40°C is considered to be special; and the ambient temperature range shall then be marked on the equipment, including either the symbol “Ta” or “Tamb” together with the special range of ambient [temperatures](#).

Informational Note: As an example, such a marking might be “-30°C ≤ Ta ≤ +40°C.”

The Section clarifies the required elements for the Temperature Classification marking and correlates with the requirements that are contained in the product standards.

Exception No. 1: Equipment of the non-heat-producing type, such as conduit fittings, shall not be required to have a marked operating temperature.

Exception No. 2: Equipment identified for Class II, Division 1 or Class II, Division 2 locations as permitted by 506.20(B) and (C) shall be permitted to be marked in accordance with 500.8(C) and Table 500.8(C).

(E) Threading. The supply connection entry thread form shall be NPT

Table 506.9(C)(2)(3) Types of Protection Designation

Designation	Technique	Zone*
iaD	Protection by intrinsic safety	20
ia	Protection by intrinsic safety	20
ibD	Protection by intrinsic safety	21
ib	Protection by intrinsic safety	21
ic	Protection by intrinsic safety	22
[iaD]	Associated apparatus	Unclassified**
[ia]	Associated apparatus	Unclassified**
[ibD]	Associated apparatus	Unclassified**
[ib]	Associated apparatus	Unclassified**
[ic]	Associated apparatus	Unclassified**
maD	Protection by encapsulation	20
ma	Protection by encapsulation	20
mbD	Protection by encapsulation	21
mb	Protection by encapsulation	21
mc	Protection by encapsulation	22
pD	Protection by pressurization	21
p	Protection by pressurization	21
pb	Protection by pressurization	21
tD	Protection by enclosures	21
ta	Protection by enclosures	21
tb	Protection by enclosures	21
tc	Protection by enclosures	21

*Does not address use where a combination of techniques is used.

**Associated apparatus is permitted to be installed in a hazardous (classified) location if suitably protected using another type of protection.

Informational Note: The “D” suffix on the type of protection designation was employed prior to the introduction of Group IIIA, IIIB, and IIIC; which is now used to distinguish between the type of protection employed for Group II (Gases) or Group III (Dusts).

The table includes the current protection techniques for Class I, Zones 0, 1, and 2 to include “ic” for intrinsic safety, “[ic]” for associated apparatus, and “mc” protection by encapsulation.

or metric. Conduit and fittings shall be made wrenchtight to prevent sparking when the fault current flows through the conduit system and to ensure the integrity of the conduit system. Equipment provided with threaded entries for field wiring connections shall be installed in accordance with 506.9(E)(1) or (E)(2) and with (E)(3).

(1) Equipment Provided with Threaded Entries for NPT-Threaded Conduit or Fittings. For equipment provided with threaded entries for NPT-threaded conduit or fittings, listed conduit fittings or [listed](#) cable fittings shall be used. All NPT-threaded conduit and fittings referred to herein shall be threaded with a National (American) Standard Pipe Taper (NPT) thread.

INTERPRETATION OF ARTICLE 506: ZONE 20, 21, AND 22 LOCATIONS FOR COMBUSTIBLE DUSTS OR IGNITABLE FIBERS/FLYINGS

Informational Note: Thread specifications for NPT threads are located in ANSI/ASME B1.20.1-1983, *Pipe Threads, General Purpose (Inch)*.

(2) Equipment Provided with Threaded Entries for Metric-Threaded Conduit or Fittings. For equipment with metric-threaded entries, listed conduit fittings or listed cable fittings shall be used. Such entries shall be identified as being metric, or listed adapters to permit connection to conduit or NPT-threaded fittings shall be provided with the equipment and shall be used for connection to conduit or NPT-threaded fittings. Metric-threaded entries shall be made up with at least five threads fully engaged.

Fittings are required to be listed when used in metric threaded entries and that there be a minimum of 5 threads engaged. If it is a conduit fitting it must be listed for use with that conduit type and if it is a cable fitting, it must be listed for use with that cable type.

(3) Unused Openings. All unused openings shall be closed with listed metal close-up plugs. The plug engagement shall comply with 506.9(E)(1) or (E)(2).

All unused openings are required to be closed in a manner that maintains the level of protection. Although this appears to be self evident it was not previously addressed in Article 506.

(F) Optical Fiber Cables. Where an optical fiber cable contains conductors that are capable of carrying current (composite optical fiber cable), the optical fiber cable shall be installed in accordance with the requirements of Articles 506.15 and 506.16.

506.15 Wiring Methods. Wiring methods shall maintain the integrity of the protection techniques and shall comply with 506.15(A), (B), or (C).

(A) Zone 20. In Zone 20 locations, the following wiring methods shall be permitted.

(1) Threaded rigid metal conduit or threaded steel intermediate metal conduit.

(2) Type MI cable terminated with fittings listed for the location. Type MI cable shall be installed and supported in a manner to avoid tensile stress at the termination fittings.

Exception No. 1: MI cable and fittings listed for Class II, Division 1 locations shall be permitted to be used.

Exception No. 2: Equipment identified as intrinsically safe “iaD” or “ia” shall be permitted to be connected using the wiring methods identified in 504.20.

The wiring methods permitted for intrinsically safe apparatus in explosive dust atmospheres classified under the zone scheme are different from those permitted under the Division scheme. The wiring methods for intrinsically safe apparatus were previously addressed in 506.8 – Protection techniques.

(3) In industrial establishments with limited public access, where the conditions of maintenance and supervision ensure that only qualified persons service the installation, Type MC-HL cable listed for use in Zone 20 locations, with a continuous corrugated metallic sheath, an overall jacket of suitable polymeric material, and a separate equipment grounding conductor(s) in accordance with 250.122, and terminated with fittings listed for the application, shall be permitted. Type MC-HL cable shall be installed in accordance with the provisions of Article 330, Part II.

Exception: Type MC-HL cable and fittings listed for Class II, Division 1 locations shall be permitted to be used.

(4) In industrial establishments with restricted public access, where the conditions of maintenance and supervision ensure that only qualified persons service the installation, and where the cable is not subject to physical damage, Type ITC-HL cable listed for use in Zone 1 or Class I, Division 1 locations, with a gas/vaportight continuous corrugated metallic sheath and an overall jacket of suitable polymeric material, and terminated with fittings listed for the application. Type ITC-HL cable shall be installed in accordance with the provisions of Article 727.

The use of ITC-HL cable is permitted in a Zone 20 location. The cable must be terminated with fittings that are listed for the application. In other words the fitting must provide the required level of protection to maintain the protection technique.

(5) Fittings and boxes shall be identified for use in Zone 20 locations.

Exception: Boxes and fittings listed for Class II, Division 1 locations shall be permitted to be used.

(6) Where necessary to employ flexible connections, liquidtight flexible metal conduit with listed fittings, liquidtight flexible nonmetallic conduit with listed fittings, or flexible cord listed for extra-hard usage and provided with listed fittings shall be used. Where flexible cords are used, they shall also comply with 506.17 and shall be terminated with a listed cord connector that maintains the type of protection of the terminal compartment. Where flexible connections are subject to oil or other corrosive conditions, the insulation of the conductors shall be of a type listed for the condition or shall be protected by means of a suitable sheath.

Cord connectors are required to be listed for the application to maintain the protection level of the terminal compartment.

Exception No. 1: Flexible conduit and flexible conduit and cord fittings listed for Class II, Division 1 locations shall be permitted to be used.

Exception No. 2: For elevator use, an identified elevator cable of Type EO, ETP, or ETT, shown under the “use” column in Table 400.4 for “hazardous (classified) locations,” and terminated with listed connectors that maintain the type of protection of the terminal compartment shall be permitted.

Informational Note No. 1: See 506.25 for grounding requirements where flexible conduit is used.

Informational Note No. 2: For further information on construction, testing, and marking of cables, cable fittings, and cord connectors, see ANSI/UL 2225-2011, *Cables and Cable-Fittings for Use in Hazardous (Classified) Locations*.

Type EO, ETP, or ETT are now specifically permitted in the Section for elevator use as these are recognized in Table 400.4 for hazardous (Classified) locations.

The wiring methods suitable for Class II, Division 1 are suitable for Zone 20.

(7) Optical fiber cable Types OFNP, OFCP, OFNR, OFCR, OFNG, OFCG, OFN, and OFC shall be permitted to be installed in raceways in accordance with 506.15(A). Optical fiber cables shall be sealed in accordance with 506.16.

This Section correlates with the permitted uses for these types of cables in Section 770.3(A).

INTERPRETATION OF ARTICLE 506: ZONE 20, 21, AND 22 LOCATIONS FOR COMBUSTIBLE DUSTS OR IGNITABLE FIBERS/FLYINGS

(B) Zone 21. In Zone 21 locations, the wiring methods in (B)(1) and (B)(2) shall be permitted.

- (1) All wiring methods permitted in 506.15(A).
- (2) Fittings and boxes that are dusttight, provided with threaded bosses for connection to conduit, in which taps, joints, or terminal connections are not made, and are not used in locations where metal dust is present, may be used.

In Zone 21, all the methods for Zone 20 are accepted as well as dusttight fittings and boxes, since the area is not as hazardous as Zone 20.

These boxes and fittings are not required to be “listed” as dusttight. For guidance on dusttight ratings see NEMA 250, Enclosures for Electrical Equipment (1000 Volts Maximum) permits a rating of “dusttight” for products that are rated NEMA Types 3, 3X, 3S, 3SX, 5, 12, 12K, or 13.

Informational Note: For further information on construction, testing, and marking of cables, cable fittings, and cord connectors, see ANSI/UL 2225-2011, Cables and Cable-Fittings for Use in Hazardous (Classified) Locations.

Exception: Equipment identified as intrinsically safe “ibD” or “ib” shall be permitted to be connected using the wiring methods identified in 504.20.

(C) Zone 22. In Zone 22 locations, the following wiring methods shall be permitted.

- (1) All wiring methods permitted in 506.15(B).
- (2) Rigid metal conduit, intermediate metal conduit, electrical metallic tubing, dusttight wireways.
- (3) Type MC or MI cable with listed termination fittings.
- (4) Type PLTC and Type PLTC-ER cable in accordance with the provisions of Article 725, including installation in cable tray systems. The cable shall be terminated with listed fittings.

Type PLTC-ER cable is permitted to be used in a Zone 22 location and where terminated with listed fittings. This simply means the fittings must be listed for the cable type. The fittings are not required to be listed for the location.

- (5) Type ITC and Type ITC-ER cable as permitted in 727.4 and terminated with listed fittings.

Type ITC-ER cable is permitted to be used in a Zone 22 location and where terminated with listed fittings. This simply means the fittings must be listed for the cable type. The fittings are not required to be listed for the location.

- (6) Type MC, MI, MV, TC, or TC-ER cable installed in ladder, ventilated trough, or ventilated channel cable trays in a single layer, with a space not less than the larger cable diameter between two adjacent cables, shall be the wiring method employed. Single-conductor Type MV cables shall be shielded or metallic armored. The cable shall be terminated with listed fittings.

Type TC-ER cable terminated with listed fittings is permitted as other Extended Run cable constructions are currently permitted. Type PLTC-ER, Type ITC-ER and Type TC-ER are all built to the same strength requirements.

(7) Intrinsic safety type of protection “ic” shall be permitted using any of the wiring methods permitted for unclassified locations. Intrinsic safety type of protection “ic” systems shall be installed in accordance with the control drawing(s). Simple apparatus, not shown on the control drawing, shall be permitted in a circuit of intrinsic safety type of protection “ic”, provided that the simple apparatus does not interconnect the intrinsic safety type of protection “ic” circuit to any other circuit.

Informational Note: The term Simple Apparatus is defined in 504.2.

Separation of circuits of intrinsic safety type of protection “ic” shall be in accordance with one of the following:

- a. Be in separate cables
- b. Be in multiconductor cables where the conductors of each circuit are within a grounded metal shield
- c. Be in multiconductor cables where the conductors have insulation with a minimum thickness of 0.25 mm (0.01 in.)

(8) Boxes and fittings shall be dusttight.

In Zone 22, any Class II, Division 1 or Division 2 wiring method is acceptable.

These boxes and fittings are not required to be “listed” as dusttight. For guidance on dusttight ratings see NEMA 250, Enclosures for Electrical Equipment (1000 Volts Maximum) permits a rating of “dusttight” for products that are rated NEMA Types 3, 3X, 3S, 3SX, 5, 12, 12K, or 13.

(9) Optical fiber cable Types OFNP, OFCP, OFNR, OFCR, OFNG, OFCG, OFN, and OFC shall be permitted to be installed in cable trays or any raceway in accordance with 506.15(C). Optical fiber cables shall be sealed in accordance with 506.16.

This Section correlates with the permitted uses for these types of cables in Section 770.3(A).

506.16 Sealing. Where necessary to protect the ingress of combustible dust or ignitable fibers/flyings, or to maintain the type of protection, seals shall be provided. The seal shall be identified as capable of preventing the ingress of combustible dust or ignitable fibers/flyings and maintaining the type of protection but need not be explosionproof or flameproof.

As with seals on intrinsically safe equipment, the seals on Zone dust equipment do not have to be explosionproof to prevent the ingress of dust. The only time explosionproof seals would be required is when the location is also classified as Zone 0, 1, or 2 as well as for Zone 20, 21, or 22, and the enclosure is rated as explosionproof for flammable gas as well as suitable for use with combustible dust.

506.17 Flexible Cords. Flexible cords used in Zone 20, Zone 21, and Zone 22 locations shall comply with all of the following:

- (1) Be of a type listed for extra-hard usage
- (2) Contain, in addition to the conductors of the circuit, an equipment grounding conductor complying with 400.23
- (3) Be connected to terminals or to supply conductors in an approved manner

INTERPRETATION OF ARTICLE 506: ZONE 20, 21, AND 22 LOCATIONS FOR COMBUSTIBLE DUSTS OR IGNITABLE FIBERS/FLYINGS

(4) Be supported by clamps or by other suitable means in such a manner to minimize tension on the terminal connections

(5) Be terminated with a listed cord connector that maintains the protection technique of the terminal compartment

Informational Note: For further information on construction, testing, and marking of cables, cable fittings, and cord connectors, see ANSI/UL 2225-2011, *Cables and Cable-Fittings for Use in Hazardous (Classified) Locations*.

The use of flexible cords is the same as that allowed for Class II locations.

506.20 Equipment Installation.

(A) Zone 20. In Zone 20 locations, only equipment listed and marked as suitable for the location shall be permitted. Exception: Equipment listed for use in Class II, Division 1 locations with a suitable temperature class shall be permitted.

(B) Zone 21. In Zone 21 locations, only equipment listed and marked as suitable for the location shall be permitted.

Exception No. 1: Apparatus listed for use in Class II, Division 1 locations with a suitable temperature class shall be permitted.

Exception No. 2: Pressurized equipment identified for Class II, Division 1 shall be permitted.

(C) Zone 22. In Zone 22 locations, only equipment listed and marked as suitable for the location shall be permitted.

Exception No. 1: Apparatus listed for use in Class II, Division 1 or Class II, Division 2 locations with a suitable temperature class shall be permitted.

Exception No. 2: Pressurized equipment identified for Class II, Division 1 or Division 2 shall be permitted.

(D) Material Group. Equipment marked Group IIIC shall be permitted for applications requiring IIIA or IIIB equipment. Similarly, equipment marked Group IIIB shall be permitted for applications requiring IIIA equipment.

This Section clarifies the elements of the material group markings that are also contained in the product standards.

(E) Manufacturer's Instructions. Electrical equipment installed in hazardous (classified) locations shall be installed in accordance with the instructions (if any) provided by the manufacturer.

(F) Temperature. The temperature marking specified in 506.9(C)(2)(5) shall comply with (E)(1) or (E)(2):

(1) For combustible dusts, less than the lower of either the layer or cloud ignition temperature of the specific combustible dust. For organic dusts that may dehydrate or carbonize, the temperature marking shall not exceed the lower of either the ignition temperature or 165°C (329°F).

(2) For ignitable fibers/flyings, less than 165°C (329°F) for equipment that is not subject to overloading, or 120°C (248°F) for equipment (such as motors or power transformers) that may be overloaded.

Informational Note: See NFPA 499-2013, *Recommended Practice for the Classification of Combustible Dusts and of Hazardous (Classified) Locations for Electrical Installations in Chemical Processing Areas*, for minimum ignition temperatures of specific dusts.

506.25 Grounding and Bonding. Regardless of the voltage of the electrical system, grounding and bonding shall comply with Article 250 and the requirements in 506.25(A) and (B).

(A) Bonding. The locknut-bushing and double-locknut types of contacts shall not be depended on for bonding purposes, but bonding jumpers with proper fittings or other approved means of bonding shall be used. Such means of bonding shall apply to all intervening raceways, fittings, boxes, enclosures, and so forth, between Zone 20, Zone 21, and Zone 22 locations and the point of grounding for service equipment or point of grounding of a separately derived system.

Exception: The specific bonding means shall be required only to the nearest point where the grounded circuit conductor and the grounding electrode conductor are connected together on the line side of the building or structure disconnecting means as specified in 250.32(B) if the branch side overcurrent protection is located on the load side of the disconnecting means.

(B) Types of Equipment Grounding Conductors. Liquidtight flexible metal conduit shall include an equipment bonding jumper of the wire type in compliance with 250.102.

Exception: In Zone 22 locations, the bonding jumper shall be permitted to be deleted where all of the following conditions are met:

(1) Listed liquidtight flexible metal conduit 1.8 m (6 ft) or less in length, with fittings listed for grounding, is used.

(2) Overcurrent protection in the circuit is limited to 10 amperes or less.

(3) The load is not a power utilization load.

These requirements are the same for Class II locations.

NOTES:

INTERPRETATION OF ARTICLE 510: HAZARDOUS (CLASSIFIED) LOCATIONS – SPECIFIC

There were no changes to Article 510 for the 2014 *NEC*® Code. This is a general Article that defines the structure of the specific locations addressed in Articles 511 through 516.

510.1 Scope. Articles 511 through 517 cover occupancies or parts of occupancies that are or may be hazardous because of atmospheric concentrations of flammable liquids, gases, or vapors, or because of deposits or accumulations of materials that may be readily ignitable.

510.2 General. The general rules of this *Code* and the provisions of Articles 500 through 504 shall apply to electrical wiring and equipment in occupancies within the scope of Articles 511 through 517, except as such rules are modified in Articles 511 through 517. Where unusual conditions exist in a specific occupancy, the authority having jurisdiction shall judge with respect to the application of specific rules.

These articles deal with specific hazardous locations and parts of those locations where highly volatile flammable gases and vapors are present. The flammable liquids covered by these articles include gasoline, jet fuels, paints and lacquers, all highly volatile flammable liquids that release large volumes of vapors and gases. Such vapors are not only dangerous near their point of release, but often at considerable distances from the liquid itself. Warning: Some locations may need to be classified as both Class I and Class II hazardous locations, such as paints.

DIVISION 1 AND DIVISION 2 DIFFERENCES.

Articles 511-517 hazardous locations are typically either outdoor applications or large indoor areas with few partitions or walls. Class I, Division 1 and Class I, Division 2 areas characteristically exist adjacent to each other -- the Division 1 location being near the point of vapor release and the Division 2 location being at a given distance from the point of release from the flammable liquid. In such locations, Division 1 means that the vapor concentration is sufficient to produce an ignitable mixture under normal conditions. A Division 2 location indicates that the vapor concentration necessary to produce a flammable mixture exists only under unusual conditions, such as an accidental rupture of a flammable liquid container or the simultaneous failure of process equipment and electrical equipment (a remote possibility).

In areas where the spread of flammable vapors and gases is not contained by adequate partitions, Class I, Division 2 can be thought of as “transition zone” between the Class I, Division 1 location and the non-hazardous area. Class I, Division 1 is a hazardous area where flammable gases or vapors are released from the liquid. Further away from the point of release, the gases or vapors are not normally of sufficient concentration to produce an ignitable mixture -- and so such an area is designated as a Class I, Division 2 location. This Class I, Division 2 location is sometimes referred to as the “transition zone.” Outside this Division 2 “transition zone” is the non-hazardous area.

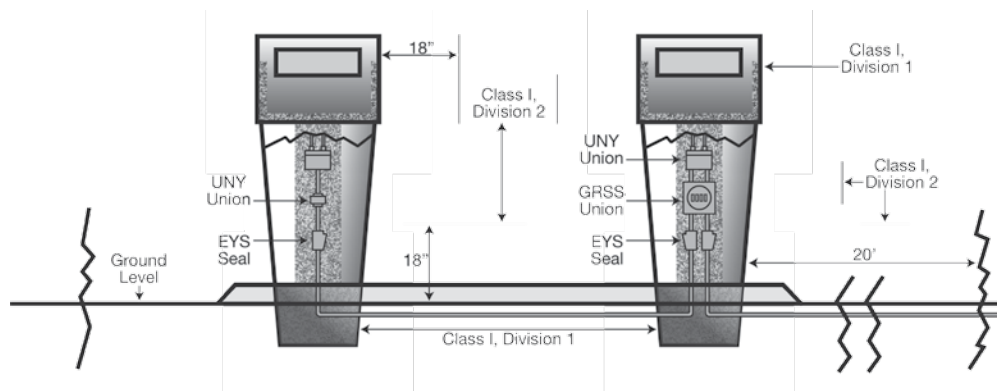

These outdoor gasoline pumps illustrate the concept of Class I, Division 2 as being “a transition zone” between a Class I, Division 1 location and a non-hazardous one. This principle also applies to indoor areas where gases or vapors are released from highly volatile flammable liquids, but where there are no unpierced walls to contain the vapors or gases. In this drawing, there is no “transition zone” at top of pumps, even though there is no partition, because the vapors (typically gasoline) are heavier than air, tending to settle toward ground level.

NOTES:

INTERPRETATION OF ARTICLE 511: COMMERCIAL GARAGES, REPAIR AND STORAGE

CHANGES TO ARTICLE 511

There were no significant revisions made to Article 511 for the 2014 Code. The changes that were made are editorial in nature.

Informational Note: Text that is followed by a reference in brackets has been extracted from NFPA 30A-2012, *Code for Motor Fuel Dispensing Facilities and Repair Garages*. Only editorial changes were made to the extracted text to make it consistent with this *Code*.

511.1 Scope. These occupancies shall include locations used for service and repair operations in connection with self-propelled vehicles (including, but not limited to, passenger automobiles, buses, trucks, and tractors) in which volatile flammable liquids or flammable gases are used for fuel or power.

The scope of Article 511 includes occupancies used for the service and repair operations in connection with self-propelled vehicles (such as, passenger automobiles, buses, trucks, and tractors.) But it is not limited to these examples. It covers occupancies in which volatile flammable liquids or flammable gases are used for fuel or power. These include gasoline, propane, compressed natural gas and liquefied natural gas.

511.2 Definitions.

Major Repair Garage. A building or portions of a building where major repairs, such as engine overhauls, painting, body and fender work, and repairs that require draining of the motor vehicle fuel tank are performed on motor vehicles, including associated floor space used for offices, parking, or showrooms. [30A:3.3.12.1]

Minor Repair Garage. A building or portions of a building used for lubrication, inspection, and minor automotive maintenance work, such as engine tune-ups, replacement of parts, fluid changes (e.g., oil, antifreeze, transmission fluid, brake fluid, air-conditioning refrigerants), brake system repairs, tire rotation, and similar routine maintenance work, including associated floor space used for offices, parking, or showrooms. [30A:3.3.12.2]

These definitions are taken directly from NFPA 30A, *Code for Motor Fuel Dispensing Facilities and Repair Garages*.

The major reference standard for this section has been changed from NFPA 88A to NFPA 30A. Additional information may be obtained in NFPA 88A-2002.

511.3 Area Classification, General. Where Class I liquids or gaseous fuels are stored, handled, or transferred, electrical wiring and electrical utilization equipment shall be designed in accordance with the requirements for Class I, Division 1 or 2 hazardous (classified) locations as classified in accordance with 500.5 and 500.6, and this article. A Class I location shall not extend beyond an unpierced wall, roof, or other solid partition that has no openings. [30A:8.3.5, 8.3.2]

(A) Parking Garages. Parking garages used for parking or storage shall be permitted to be unclassified.

Informational Note: For further information, see NFPA 88A- 2011, *Standard for Parking Structures*, and NFPA 30A-2012, *Code for Motor Fuel Dispensing Facilities and Repair Garages*.

(B) Repair Garages, With Dispensing. Major and minor repair garages that dispense motor fuels into the fuel tanks of vehicles,

including flammable liquids having a flash point below 38°C (100°F) such as gasoline, or gaseous fuels such as natural gas, hydrogen, or LPG, shall have the dispensing functions and components classified in accordance with Table 514.3(B)(1) in addition to any classification required by this section. Where Class I liquids, other than fuels, are dispensed, the area within 900 mm (3 ft) of any fill or dispensing point, extending in all directions, shall be a Class I, Division 2 location.

(C) Major Repair Garages. Where flammable liquids having a flash point below 38°C (100°F) such as gasoline, or gaseous fuels such as natural gas, hydrogen, or LPG, will not be dispensed, but repair activities that involve the transfer of such fluids or gases are performed, the classification rules in (1), (2), and (3) shall apply.

(1) Floor Areas.

(a) *Ventilation Provided.* The floor area shall be unclassified where there is mechanical ventilation providing a minimum of four air changes per hour or 0.3 m³/min/m² (1 cfm/ft²) of exchanged air for each square meter (foot) of floor area. Ventilation shall provide for air exchange across the entire floor area, and exhaust air shall be taken at a point within 0.3 m (12 in.) of the floor.

(b) *Ventilation Not Provided.* The entire floor area up to a level of 450 mm (18 in.) above the floor shall be classified as Class I, Division 2 if the ventilation does not comply with 511.3(C)(1)(a).

(2) Ceiling Areas. Where lighter-than-air gaseous fueled vehicles, such as vehicles fueled by natural gas or hydrogen, are repaired or stored, the area within 450 mm (18 in.) of the ceiling shall be considered for classification in accordance with (a) and (b).

(a) *Ventilation Provided.* The ceiling area shall be unclassified where ventilation is provided, from a point not more than 450 mm (18 in.) from the highest point in the ceiling, to exhaust the ceiling area at a rate of not less than 0.3 m³/min/m² (1 cfm/ft²) of ceiling area at all times that the building is occupied or when vehicles using lighter-than-air gaseous fuels are parked below this area.

(b) *Ventilation Not Provided.* Ceiling areas that are not ventilated in accordance with 511.3(C)(2)(a) shall be classified as Class I, Division 2.

(3) Pit Areas in Lubrication or Service Room. Any pit, belowgrade work area, or subfloor work area shall be classified as provided in (a) or (b).

(a) *Ventilation Provided.* The pit area shall be a Class I, Division 2 location where there is mechanical ventilation providing a minimum of six air changes per hour.

(b) *Ventilation Not Provided.* Where ventilation is not provided in accordance with 511.3(C)(3)(a), any pit or depression below floor level shall be a Class I, Division 1 location that extends up to the floor level.

(D) Minor Repair Garages. Where flammable liquids having a flash point below 38°C (100°F) such as gasoline, or gaseous fuels such as natural gas or hydrogen, will not be dispensed or transferred, the classification rules in (D)(1), (D)(2), and (D)(3) shall apply to the lubrication and service rooms.

(1) Floor Areas. Floor areas in minor repair garages without pits, belowgrade work areas, or subfloor work areas shall be unclassified. Where floor areas include pits, belowgrade work areas, or subfloor work areas in lubrication or service rooms, the classification rules in (a) or (b) shall apply.

INTERPRETATION OF ARTICLE 511: COMMERCIAL GARAGES, REPAIR AND STORAGE

(a) *Ventilation Provided.* The entire floor area shall be unclassified where there is mechanical ventilation providing a minimum of four air changes per hour or $0.3 \text{ m}^3/\text{min}/\text{m}^2$ ($1 \text{ cfm}/\text{ft}^2$) of exchanged air for each square meter (foot) of floor area. Ventilation shall provide for air exchange across the entire floor area, and exhaust air shall be taken at a point within 0.3 m (12 in.) of the floor.

(b) *Ventilation Not Provided.* The floor area up to a level of 450 mm (18 in.) above any unventilated pit, belowgrade work area, or subfloor work area and extending a distance of 900 mm (3 ft) horizontally from the edge of any such pit, belowgrade work area, or subfloor work area, shall be classified as Class I, Division 2.

(2) **Ceiling Areas.** Where lighter-than-air gaseous fuels (such as natural gas or hydrogen) will not be transferred, such locations shall be unclassified.

(3) **Pit Areas in Lubrication or Service Room.** Any pit, belowgrade work area, or subfloor work area shall be classified as provided in (a) or (b).

(a) *Ventilation Provided.* Where ventilation is provided to exhaust the pit area at a rate of not less than $0.3 \text{ m}^3/\text{min}/\text{m}^2$ ($1 \text{ cfm}/\text{ft}^2$) of floor area at all times that the building is occupied, or when vehicles are parked in or over this area and where exhaust air is taken from a point within 300 mm (12 in.) of the floor of the pit, belowgrade work area, or subfloor work area, the pit shall be unclassified. [30A:7.4.5.4. Table 8.3.1]

(b) *Ventilation Not Provided.* Where ventilation is not provided in accordance with 511.3(D)(3)(a), any pit or depression below floor level shall be a Class I, Division 2 location that extends up to the floor level.

(E) Modifications to Classification.

(1) **Specific Areas Adjacent to Classified Locations.** Areas adjacent to classified locations in which flammable vapors are not likely to be released, such as stock rooms, switchboard rooms, and other similar locations, shall be unclassified where mechanically ventilated at a rate of four or more air changes per hour, or designed with positive air pressure, or where effectively cut off by walls or partitions.

(2) **Alcohol-Based Windshield Washer Fluid.** The area used for storage, handling, or dispensing into motor vehicles of alcohol-based windshield washer fluid in repair garages shall be unclassified unless otherwise classified by a provision of 511.3. [30A:8.3.5, Exception]

The classification of locations include the requirements based on the garage categories.

511.4 Wiring and Equipment in Class I Locations.

(A) **Wiring Located in Class I Locations.** Within Class I locations as classified in 511.3, wiring shall conform to applicable provisions of Article 501.

(B) **Equipment Located in Class I Locations.** Within Class I locations as defined in 511.3, equipment shall conform to applicable provisions of Article 501.

(1) **Fuel-Dispensing Units.** Where fuel-dispensing units (other than liquid petroleum gas, which is prohibited) are located within buildings, the requirements of Article 514 shall govern.

Where mechanical ventilation is provided in the dispensing area, the control shall be interlocked so that the dispenser cannot operate without ventilation, as prescribed in 500.5(B)(2).

(2) **Portable Lighting Equipment.** Portable lighting equipment shall be equipped with handle, lampholder, hook, and substantial guard attached to the lampholder or handle. All exterior surfaces that might come in contact with battery terminals, wiring terminals, or other objects shall be of nonconducting material or shall be effectively protected with insulation. Lampholders shall be of an unswitched type and shall not provide means for plug-in of attachment plugs. The outer shell shall be of molded composition or other suitable material. Unless the lamp and its cord are supported or arranged in such a manner that they cannot be used in the locations classified in 511.3, they shall be of a type identified for Class I, Division 1 locations.

511.7 Wiring and Equipment Installed Above Class I Locations.

(A) Wiring in Spaces Above Class I Locations.

(1) **Fixed Wiring Above Class I Locations.** All fixed wiring above Class I locations shall be in metal raceways, rigid nonmetallic conduit, electrical nonmetallic tubing, flexible metal conduit, liquidtight flexible metal conduit, or liquidtight flexible nonmetallic conduit, or shall be Type MC, AC, MI, manufactured wiring systems, or PLTC cable in accordance with Article 725, or Type TC cable or Type ITC cable in accordance with Article 727. Cellular metal floor raceways or cellular concrete floor raceways shall be permitted to be used only for supplying ceiling outlets or extensions to the area below the floor, but such raceways shall have no connections leading into or through any Class I location above the floor.

Section 511.7(A)(1) was modified to include type AC cable as an acceptable wiring method for areas above Class I locations.

(2) **Pendant.** For pendants, flexible cord suitable for the type of service and listed for hard usage shall be used.

(B) Electrical Equipment Installed Above Class I Locations.

(1) **Fixed Electrical Equipment.** Electrical equipment in a fixed position shall be located above the level of any defined Class I location or shall be identified for the location.

(a) *Arcing Equipment.* Equipment that is less than 3.7 m (12 ft) above the floor level and that may produce arcs, sparks, or particles of hot metal, such as cutouts, switches, charging panels, generators, motors, or other equipment (excluding receptacles, lamps, and lampholders) having make-and-break or sliding contacts, shall be of the totally enclosed type or constructed so as to prevent the escape of sparks or hot metal particles.

(b) *Fixed Lighting.* Lamps and lampholders for fixed lighting that is located over lanes through which vehicles are commonly driven or that may otherwise be exposed to physical damage shall be located not less than 3.7 m (12 ft) above floor level, unless of the totally enclosed type or constructed so as to prevent escape of sparks or hot metal particles

511.9 **Sealing.** Seals complying with the requirements of 501.15 and 501.15(B)(2) shall be provided and shall apply to horizontal as well as vertical boundaries of the defined Class I locations.

511.10 Special Equipment.

(A) **Battery Charging Equipment.** Battery chargers and their control equipment, and batteries being charged, shall not be located within locations classified in 511.3.

(B) **Electric Vehicle Charging Equipment.**

INTERPRETATION OF ARTICLE 511: COMMERCIAL GARAGES, REPAIR AND STORAGE

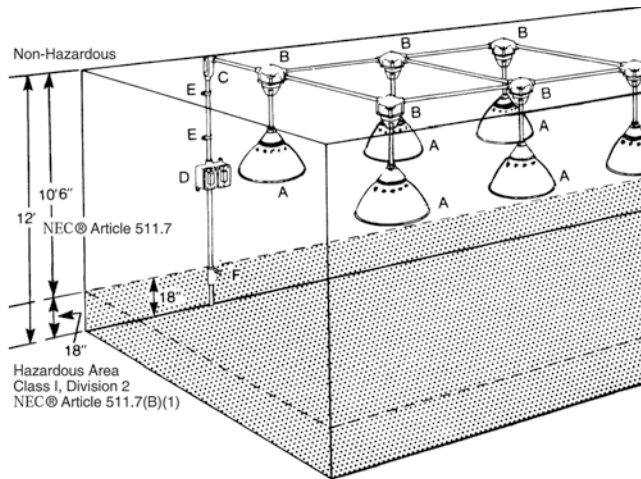

LUMINAIRES (A) AND FS OR FD BOXES (D) ILLUSTRATED HERE MAY BE INSTALLED LESS THAN 12 FEET FROM THE FLOOR LEVEL BECAUSE THEY MEET SECTION 511.7(B)(1) REQUIREMENT OF BEING "TOTALLY ENCLOSED." THE LUMINAIRES (A) ARE ENCLOSED AND GASKETED AND THE FS/FD (D) UNITS ARE ENCLOSED WITH GASKETED COVERS. SPARKS OR HOT METAL PARTICLES ARE CONTAINED BY THE COVERS OR ENCLOSURES (B) AND CANNOT BE TRANSMITTED THROUGH THE CONDUIT TO THE HAZARDOUS AREA NEAR THE FLOOR BECAUSE OF THE SEAL (F).

- A—CLASS I, DIVISION 2 LUMINAIRES
- B—ENCLOSED AND GASKETED FIXTURE HANGERS
- C—CONDUIT BODY
- D—FS OR FD WEATHERPROOF COVER
- E—MALLEABLE IRON CLAMPS AND CLAMP BACKS
- F—EXPLOSIONPROOF SEALS

TOTALLY ENCLOSED DEVICES (KEYED "D" LEFT).



FS BOX AND COVER



GFI COVER

TOTALLY ENCLOSED LUMINAIRES (KEYED "A" LEFT).



MERCMASTER III



STYLMASTER



VIAMASTER

TOTALLY ENCLOSED FITTINGS



FM7 SERIES



FM8 SERIES



FORM 85



FORM 35

FIXTURE HANGERS (KEYED "B" LEFT).



GS CUSHION TYPE



AHG CUSHION TYPE



T FITTING WITH AHG TYPE HANGER



T FITTING

INTERPRETATION OF ARTICLE 511: COMMERCIAL GARAGES, REPAIR AND STORAGE

(1) **General.** All electrical equipment and wiring shall be installed in accordance with Article 625, except as noted in 511.10(B)(2) and (B)(3). Flexible cords shall be of a type identified for extra-hard usage.

(2) **Connector Location.** No connector shall be located within a Class I location as defined in 511.3.

(3) **Plug Connections to Vehicles.** Where the cord is suspended from overhead, it shall be arranged so that the lowest point of sag is at least 150 mm (6 in.) above the floor. Where an automatic arrangement is provided to pull both cord and plug beyond the range of physical damage, no additional connector shall be required in the cable or at the outlet.

511.12 Ground-Fault Circuit-Interrupter Protection for Personnel. All 125-volt, single-phase, 15- and 20-ampere receptacles installed in areas where electrical diagnostic equipment, electrical hand tools, or portable lighting equipment are to be used shall have ground-fault circuit-interrupter protection for personnel.

511.16 Grounding and Bonding Requirements.

(A) **General Grounding Requirements.** All metal raceways, the metal armor or metallic sheath on cables, and all non-current-carrying metal parts of fixed or portable electrical equipment, regardless of voltage, shall be grounded.

(B) **Supplying Circuits with Grounded and Grounding Conductors in Class I Locations.** Grounding in Class I locations shall comply with 501.30.

(1) **Circuits Supplying Portable Equipment or Pendants.** Where a circuit supplies portables or pendants and includes a grounded conductor as provided in Article 200, receptacles, attachment plugs, connectors, and similar devices shall be of the grounding type, and the grounded conductor of the flexible cord shall be connected to the screw shell of any lampholder or to the grounded terminal of any utilization equipment supplied.

(2) **Approved Means.** Approved means shall be provided for maintaining continuity of the equipment grounding conductor between the fixed wiring system and the non-current-carrying metal portions of pendant luminaires, portable luminaires, and portable utilization equipment.

INTERPRETATION OF ARTICLE 513: AIRCRAFT HANGARS

CHANGES TO ARTICLE 513

There were no significant revisions made to Article 513 for the 2014 Code. The changes that were made are editorial in nature.

513.1 Scope. This article shall apply to buildings or structures in any part of which aircraft containing Class I (flammable) liquids or Class II (combustible) liquids whose temperatures are above their flash points are housed or stored and in which aircraft might undergo service, repairs, or alterations. It shall not apply to locations used exclusively for aircraft that have never contained fuel or unfueled aircraft.

Informational Note No. 1: For definitions of aircraft hangar and unfueled aircraft, see NFPA 409-2011, *Standard on Aircraft Hangars*.

Informational Note No. 2: For further information on fuel classification see NFPA 30-2012, *Flammable and Combustible Liquids Code*.

Article 513 allows use of the Zone classification system as described in Article 505. This is possible since aircraft hangars are not open to the general public, and desirable, since major airlines and the U.S. Armed Forces operate aircraft hangars worldwide.

513.2 Definitions. For the purpose of this article, the following definitions shall apply.

Aircraft Painting Hangar. An aircraft hangar constructed for the express purpose of spray/coating/dipping applications and provided with dedicated ventilation supply and exhaust.

Mobile Equipment. Equipment with electrical components suitable to be moved only with mechanical aids or is provided with wheels for movement by person(s) or powered devices.

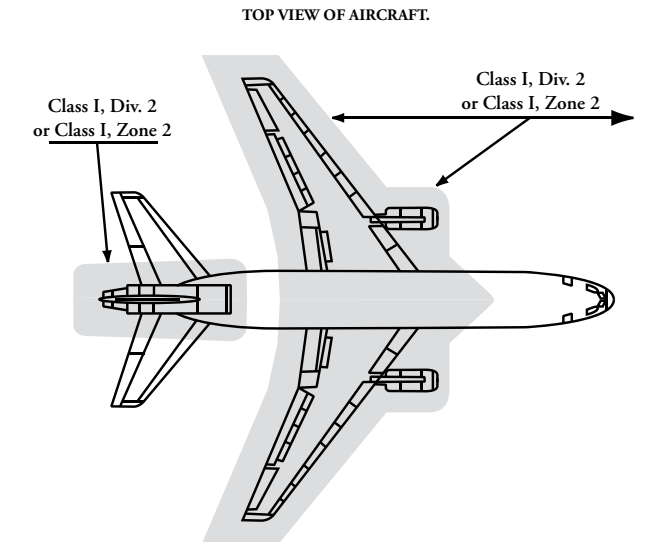

THIS VIEW FROM THE TOP SHOWS CLASS I, DIVISION 2 OR ZONE 2 AREAS AROUND THE AIRCRAFT ENGINES AND WINGS (WHICH CONTAIN FUEL TANKS). THESE ZONES EXTEND HORIZONTALLY 5 FEET IN ALL DIRECTIONS AND EXTEND UPWARD FROM FLOOR LEVEL TO 5 FEET ABOVE THE HIGHEST SURFACE OF THE WING OR ENGINE ENCLOSURES, WHICHEVER IS HIGHEST.

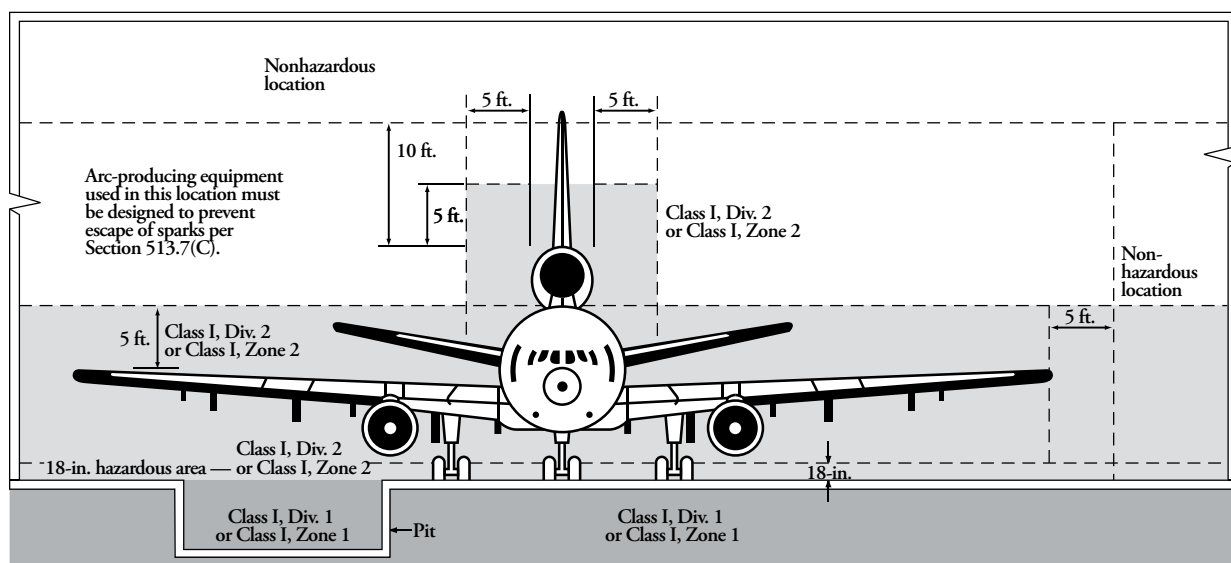

THE AREA SHOWN IN THE DRAWING MORE THAN 5 FEET ABOVE THE WING IS NORMALLY NON-HAZARDOUS. HOWEVER, ARC-PRODUCING EQUIPMENT THAT IS NOT CAPABLE OF CONTAINING SPARKS OR HOT METAL PARTICLES IS NOT PERMITTED IN THIS AREA, BECAUSE SUCH IGNITIONS MIGHT REACH THE HAZARDOUS AREA BELOW. SECTION 513.7(C) FORBIDS THE USE OF SUCH EQUIPMENT THAT IS LESS THAN 10 FEET ABOVE THE WING AND ENGINES. BECAUSE THE ENGINE IN THE TAIL IS THE HIGHEST POINT OF THIS PARTICULAR AIRCRAFT, THE AREA EXTENDS 10 FEET ABOVE THE REAR ENGINE, RATHER THAN FROM THE WING.

INTERPRETATION OF ARTICLE 513: AIRCRAFT HANGARS

Portable Equipment (as applied to Article 513). Equipment with electrical components suitable to be moved by a single person without mechanical aids.

513.3 Classification of Locations.

(A) Below Floor Level. Any pit or depression below the level of the hangar floor shall be classified as a Class I, Division 1 or Zone 1 location that shall extend up to said floor level.

(B) Areas Not Cut Off or Ventilated. The entire area of the hangar, including any adjacent and communicating areas not suitably cut off from the hangar, shall be classified as a Class I, Division 2 or Zone 2 location up to a level 450 mm (18 in.) above the floor.

(C) Vicinity of Aircraft.

(1) Aircraft Maintenance and Storage Hangars. The area within 1.5 m (5 ft) horizontally from aircraft power plants or aircraft fuel tanks shall be classified as a Class I, Division 2 or Zone 2 location that shall extend upward from the floor to a level 1.5 m (5 ft) above the upper surface of wings and of engine enclosures.

(2) Aircraft Painting Hangars. The area within 3 m (10 ft) horizontally from aircraft surfaces from the floor to 3 m (10 ft) above the aircraft shall be classified as Class I, Division 1 or Class I, Zone 1. The area horizontally from aircraft surfaces between 3.0 m (10 ft) and 9.0 m (30 ft) from the floor to 9.0 m (30 ft) above the aircraft surface shall be classified as Class I, Division 2 or Class I, Zone 2.

Informational Note: See NFPA 33-2011, *Standard for Spray Application Using Flammable or Combustible Materials*, for information on ventilation and grounding for static protection in spray painting areas.

(D) Areas Suitably Cut Off and Ventilated. Adjacent areas in which flammable liquids or vapors are not likely to be released, such as stock rooms, electrical control rooms, and other similar locations, shall be unclassified where adequately ventilated and where effectively cut off from the hangar itself by walls or partitions.

513.4 Wiring and Equipment in Class I Locations.

(A) General. All wiring and equipment that is or may be installed or operated within any of the Class I locations defined in 513.3 shall comply with the applicable provisions of Article 501 or Article 505 for the division or zone in which they are used.

Attachment plugs and receptacles in Class I locations shall be identified for Class I locations or shall be designed such that they cannot be energized while the connections are being made or broken.

(B) Stanchions, Rostrums, and Docks. Electrical wiring, outlets, and equipment (including lamps) on or attached to stanchions, rostrums, or docks that are located or likely to be located in a Class I location, as defined in 513.3(C), shall comply with the applicable provisions of Article 501 or Article 505 for the division or zone in which they are used.

513.7 Wiring and Equipment Not Installed in Class I Locations.

(A) Fixed Wiring. All fixed wiring in a hangar but not installed in a Class I location as classified in 513.3 shall be installed in metal raceways or shall be Type MI, TC, or MC cable.

Exception: Wiring in unclassified locations, as described in 513.3(D), shall be permitted to be any suitable type wiring method recognized in Chapter 3.

STATIC ELECTRICITY.

The flow of flammable liquids through non-conducting materials can generate static electricity. Therefore the aircraft and truck dispensing the fuel need to be grounded to safely dissipate the static charge. An effective method of providing such safety is through the use of Appleton Static Grounding Reel installed on a truck. Alligator Clip attaches to TGP Grounding Stud, which is permanently installed on the aircraft. The other Alligator Clip attaches to ground.



STATIC DISCHARGE GROUNDING REEL (SD SERIES)



TGP GROUNDING STUD AND TGR GROUNDING PLUG

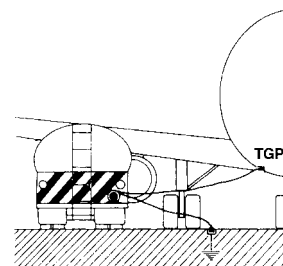

GROUNDING REEL INSTALLED ON A TRUCK. ALLIGATOR CLIP ATTACHES TO TGP GROUNDING STUD, WHICH IS PERMANENTLY INSTALLED ON THE AIRCRAFT. THE OTHER ALLIGATOR CLIP ATTACHES TO GROUND.

The exception in Section 513.7(A) states that wiring methods used shall be any Chapter 3 method that is suitable, instead of any recognized method from Chapter 3.

(B) Pendants. For pendants, flexible cord suitable for the type of service and identified for hard usage or extra-hard usage shall be used. Each such cord shall include a separate equipment grounding conductor.

(C) Arcing Equipment. In locations above those described in 513.3, equipment that is less than 3.0 m (10 ft) above wings and engine enclosures of aircraft and that may produce arcs, sparks, or particles of hot metal, such as lamps and lampholders for fixed lighting, cutouts, switches, receptacles, charging panels, generators, motors, or other equipment having make-and-break or sliding contacts, shall be of the totally enclosed type or constructed so as to prevent the escape of sparks

INTERPRETATION OF ARTICLE 513: AIRCRAFT HANGERS

or hot metal particles.

Exception: Equipment in areas described in 513.3(D) shall be permitted to be of the general-purpose type.

(D) Lampholders. Lampholders of metal-shell, fiber-lined types shall not be used for fixed incandescent lighting.

(E) Stanchions, Rostrums, or Docks. Where stanchions, rostrums, or docks are not located or likely to be located in a Class I location, as defined in 513.3(C), wiring and equipment shall comply with 513.7, except that such wiring and equipment not more than 457 mm (18 in.) above the floor in any position shall comply with 513.4(B). Receptacles and attachment plugs shall be of a locking type that will not readily disconnect.

(F) Mobile Stanchions. Mobile stanchions with electrical equipment complying with 513.7(E) shall carry at least one permanently affixed warning sign with the following words or equivalent:

WARNING
KEEP 5 FT CLEAR OF AIRCRAFT
ENGINES AND FUEL TANK AREAS
or
WARNING
KEEP 1.5 METERS CLEAR OF AIRCRAFT
ENGINES AND FUEL TANK AREAS

513.8 Underground Wiring.

(A) Wiring and Equipment Embedded, Under Slab, or Underground. All wiring installed in or under the hangar floor shall comply with the requirements for Class I, Division 1 locations. Where such wiring is located in vaults, pits, or ducts, adequate drainage shall be provided.

(B) Uninterrupted Raceways, Embedded, Under Slab, or Underground. Uninterrupted raceways that are embedded in a hangar floor or buried beneath the hangar floor shall be considered to be within the Class I location above the floor, regardless of the point at which the raceway descends below or rises above the floor.

513.9 Sealing. Seals shall be provided in accordance with 501.15 or 505.16, as applicable. Sealing requirements specified shall apply to horizontal as well as to vertical boundaries of the defined Class I locations.

The sealing section was reworded to reflect the harmonized sealing language used in the other Articles.

513.10 Special Equipment.

(A) Aircraft Electrical Systems.

(1) De-energizing Aircraft Electrical Systems. Aircraft electrical systems shall be de-energized when the aircraft is stored in a hangar and, whenever possible, while the aircraft is undergoing maintenance.

(2) Aircraft Batteries. Aircraft batteries shall not be charged where installed in an aircraft located inside or partially inside a hangar.

(B) Aircraft Battery Charging and Equipment. Battery chargers and their control equipment shall not be located or operated within any of

the Class I locations defined in 513.3 and shall preferably be located in a separate building or in an area such as defined in 513.3(D). Mobile chargers shall carry at least one permanently affixed warning sign with the following words or equivalent:

WARNING
KEEP 5 FT CLEAR OF AIRCRAFT ENGINES
AND FUEL TANK AREAS
or
WARNING
KEEP 1.5 METERS CLEAR OF AIRCRAFT
ENGINES AND FUEL TANK AREAS

Tables, racks, trays, and wiring shall not be located within a Class I location and, in addition, shall comply with Article 480.

(C) External Power Sources for Energizing Aircraft.

(1) Not Less Than 450 mm (18 in.) Above Floor. Aircraft energizers shall be designed and mounted such that all electrical equipment and fixed wiring will be at least 450 mm (18 in.) above floor level and shall not be operated in a Class I location as defined in 513.3(C).

(2) Marking for Mobile Units. Mobile energizers shall carry at least one permanently affixed warning sign with the following words or equivalent:

WARNING
KEEP 5 FT CLEAR OF AIRCRAFT
ENGINES AND FUEL TANK AREAS
or
WARNING
KEEP 1.5 METERS CLEAR OF AIRCRAFT
ENGINES AND FUEL TANK AREAS

(3) Cords. Flexible cords for aircraft energizers and ground support equipment shall be identified for the type of service and extra-hard usage and shall include an equipment grounding conductor.

(D) Mobile Servicing Equipment with Electrical Components.

(1) General. Mobile servicing equipment (such as vacuum cleaners, air compressors, air movers) having electrical wiring and equipment not suitable for Class I, Division 2 or Zone 2 locations shall be so designed and mounted that all such fixed wiring and equipment will be at least 450 mm (18 in.) above the floor. Such mobile equipment shall not be operated within the Class I location defined in 513.3(C) and shall carry at least one permanently affixed warning sign with the following words or equivalent:

WARNING
KEEP 5 FT CLEAR OF AIRCRAFT ENGINES
AND FUEL TANK AREAS
or
WARNING
KEEP 1.5 METERS CLEAR OF AIRCRAFT ENGINES
AND FUEL TANK AREAS

INTERPRETATION OF ARTICLE 513: AIRCRAFT HANGERS

(2) **Cords and Connectors.** Flexible cords for mobile equipment shall be suitable for the type of service and identified for extra-hard usage and shall include an equipment grounding conductor. Attachment plugs and receptacles shall be identified for the location in which they are installed and shall provide for connection of the equipment grounding conductor.

(3) **Restricted Use.** Equipment that is not identified as suitable for Class I, Division 2 locations shall not be operated in locations where maintenance operations likely to release flammable liquids or vapors are in progress.

(E) **Portable Equipment.**

(1) **Portable Lighting Equipment.** Portable lighting equipment that is used within a hangar shall be identified for the location in which they are used. For portable luminaires, flexible cord suitable for the type of service and identified for extra-hard usage shall be used. Each such cord shall include a separate equipment grounding conductor.

(2) **Portable Utilization Equipment.** Portable utilization equipment that is or may be used within a hangar shall be of a type suitable for use in Class I, Division 2 or Zone 2 locations. For portable utilization equipment, flexible cord suitable for the type of service and approved for extra-hard usage shall be used. Each such cord shall include a separate equipment grounding conductor.

513.12 Ground-Fault Circuit-Interrupter Protection for Personnel.

All 125-volt, 50/60-Hz, single-phase, 15- and 20-ampere receptacles installed in areas where electrical diagnostic equipment, electrical hand tools, or portable lighting equipment are to be used shall have ground-fault circuit-interrupter protection for personnel.

Section 513.12 brings aircraft hangars in line with commercial garages in requiring ground-fault circuit interrupter protection for personnel. Receptacles that provide 400 Hz power for aircraft equipment are not covered by this requirement.

513.16 Grounding and Bonding Requirements.

(A) **General Grounding Requirements.** All metal raceways, the metal armor or metallic sheath on cables, and all non-current-carrying metal parts of fixed or portable electrical equipment, regardless of voltage, shall be grounded. Grounding in Class I locations shall comply with 501.30 for Class I, Division 1 and 2 locations and 505.25 for Class I, Zone 0, 1, and 2 locations.

(B) **Supplying Circuits with Grounded and Grounding Conductors in Class I Locations.**

(1) **Circuits Supplying Portable Equipment or Pendants.** Where a circuit supplies portables or pendants and includes a grounded conductor as provided in Article 200, receptacles, attachment plugs, connectors, and similar devices shall be of the grounding type, and the grounded conductor of the flexible cord shall be connected to the screw shell of any lampholder or to the grounded terminal of any utilization equipment supplied.

(2) **Approved Means.** Approved means shall be provided for maintaining continuity of the grounding conductor between the fixed wiring system and the non-current-carrying metal portions of pendant luminaires, portable luminaires, and portable utilization equipment.



INSTALLATION OF LUMINAIRES IN JET FUEL AREA.

INTERPRETATION OF ARTICLE 514: MOTOR FUEL DISPENSING FACILITIES

CHANGES TO ARTICLE 514

The following Article 514 sections have been revised during the 2014 *NEC*® Code cycle. These changes are those that are substantive and should be noted. This list does not include those changes that are editorial in nature.

Underlined text indicates a section that has been revised from the previous *NEC*® edition. It is not intended to indicate legislation text detailing the word-for-word revisions to the section. Where minor revisions have been made to a section, these will include underlined text for select words to indicate the minor revision.

- **Figure 514.3(B)**
Classification of Locations. Classified Areas Adjacent to Dispenser Mounted on Aboveground Storage Tank
- **Section 514.3(C)(New)**
Classification of Locations. Motor Fuel Dispensing Stations in Boatyards and Marinas
- **Section 514.13**
Provision for Maintenance and Service of Dispensing Equipment

Informational Note: Text that is followed by a reference in brackets has been extracted from NFPA 30A-2012, *Code for Motor Fuel Dispensing Facilities and Repair Garages*. Only editorial changes were made to the extracted text to make it consistent with this Code.

514.1 Scope. This article shall apply to motor fuel dispensing facilities, marine/motor fuel dispensing facilities, motor fuel dispensing facilities located inside buildings, and fleet vehicle motor fuel dispensing facilities.

Informational Note: For further information regarding safeguards for motor fuel dispensing facilities, see NFPA 30A-2012, *Code for Motor Fuel Dispensing Facilities and Repair Garages*.

The scope specifically includes marine fuel dispensing facilities and motor fuel dispensing facilities located inside buildings, such as those in commercial garages.

514.2 Definition.

Motor Fuel Dispensing Facility. That portion of a property where motor fuels are stored and dispensed from fixed equipment into the fuel tanks of motor vehicles or marine craft or into approved containers, including all equipment used in connection therewith. [30A:3.3.11]

Informational Note: Refer to Articles 510 and 511 with respect to electrical wiring and equipment for other areas used as lubrication rooms, service rooms, repair rooms, offices, salesrooms, compressor rooms, and similar locations.

The definition of Motor Fuel Dispensing facility was extracted from NFPA 30A.

514.3 Classification of Locations. [See Figure 514.3.]

(A) Unclassified Locations. Where the authority having jurisdiction can satisfactorily determine that flammable liquids having a flash point below 38°C (100°F), such as gasoline, will not be handled, such location shall not be required to be classified.

(B) Classified Locations. [See Figure 514.3(B).]

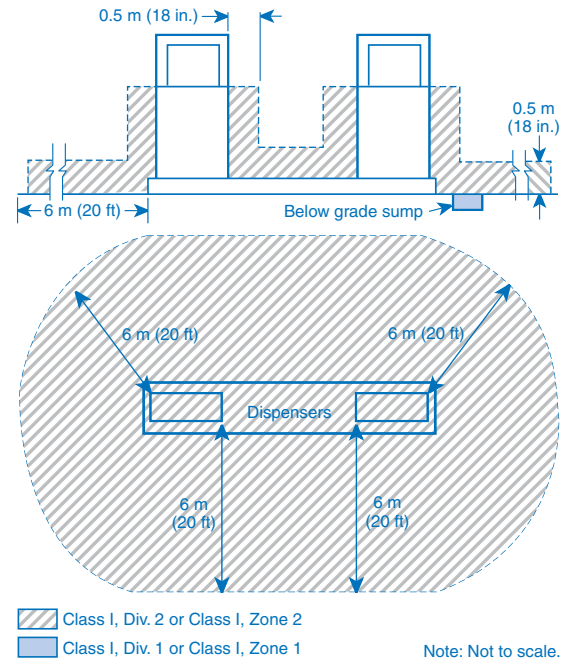

Figure 514.3. Classified Areas Adjacent to Dispensers [30A: Figure 8.3.2(a)]

Figure 514.3 depicts, in a general way, the extent of Class I, Division 1 and Class I, Division 2 spaces in service station locations.

(1) Class I Locations. Table 514.3(B)(1) shall be applied where Class I liquids are stored, handled, or dispensed and shall be used to delineate and classify motor fuel dispensing facilities and commercial garages as defined in Article 511. Table 515.3 shall be used for the purpose of delineating and classifying aboveground tanks. A Class I location shall not extend beyond an unpierced wall, roof, or other solid partition. [30A:8.1, 8.3]

(2) Compressed Natural Gas, Liquefied Natural Gas, and Liquefied Petroleum Gas Areas. Table 514.3(B)(2) shall be used to delineate and classify areas where compressed natural gas (CNG), liquefied natural gas (LNG), or liquefied petroleum gas (LPG) is stored, handled, or dispensed. Where CNG or LNG dispensers are installed beneath a canopy or enclosure, either the canopy or the enclosure shall be designed to prevent accumulation or entrapment of ignitable vapors, or all electrical equipment installed beneath the canopy or enclosure shall be suitable for Class I, Division 2 hazardous (classified) locations. Dispensing devices for liquefied petroleum gas shall be located not less than 1.5 m (5 ft) from any dispensing device for Class I liquids. [30A:12.1, 12.4, 12.5]

Informational Note No. 1: For information on area classification where liquefied petroleum gases are dispensed, see NFPA 58-2014, *Liquefied Petroleum Gas Code*.

Informational Note No. 2: For information on classified areas pertaining to LP-Gas systems other than residential or commercial, see NFPA 58-2014, *Liquefied Petroleum Gas Code*, and NFPA 59-2012, *Utility LP-Gas Plant Code*.

Informational Note No. 3: See 514.3(C) for motor fuel dispensing stations in marinas and boatyards.

INTERPRETATION OF ARTICLE 514: MOTOR FUEL DISPENSING FACILITIES

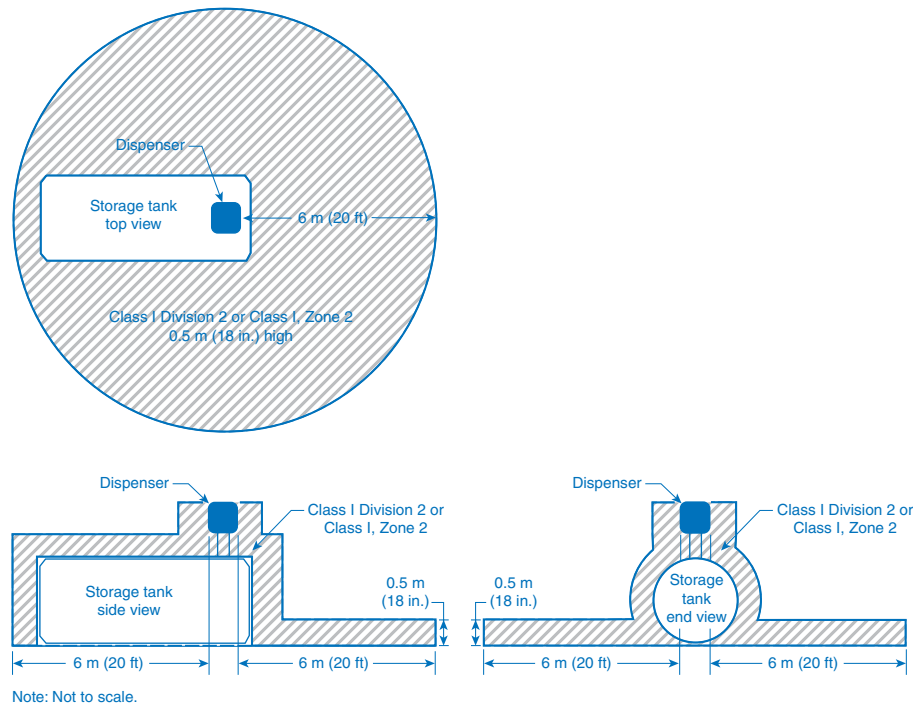

Figure 514.3(B) Classified Areas Adjacent to Dispenser Mounted on Aboveground Storage Tank. [30A: Figure 8.3.2(b)]

Table 514.3(B)(1) contains precise delineation of Class I, Division 1 spaces, referencing the publication ANSI/UL 87, Power Operated Dispensing Devices for Petroleum Products. Primary change is the space within the dispenser, some of which is not now designated as Class I, Division 1. This publication is also referenced to indicate Class I, Division 2 spaces. The Table is based on Table 8.3.1 of NFPA 30A, Code for Motor Fuel Dispensing Facilities and Repair Garages. The Table includes the appropriate Zone locations. Note that in accordance with section 514.9 seals are the first fittings installed after the conduit emerges from the concrete and that seals are installed in each conduit entering the dispensers.

OUTDOOR/INDOOR DISPENSERS.

Any outdoor area or any indoor area with mechanical ventilation within 20 feet of a gas pump up to 18 inches above grade level is Class I, Division 2. If the indoor area has gravity ventilation, a 25-foot horizontal distance from any edge of the enclosure is required. For “Dispensing Units” see sketch above.

REMOTE PUMPING SYSTEMS.

Where Class I liquids are transferred from storage to individual or multiple dispensing units by pumps located elsewhere than at the dispensing units.

Outdoor. Any pit, box or space below grade level is Class I, Division 1 if any part is within a 10-foot horizontal distance from any edge of pump.

Indoor. Entire space within a pit is Class I, Division 1.

ABOVE GROUND STORAGE TANKS.

Figure 514.3(B) has been added to depict the classified areas adjacent to dispenser mounted on aboveground storage tank. This figure is extracted from NFPA 30A.

WIRING AND EQUIPMENT NOT WITHIN CLASS I DISPENSING AREAS.

Wiring and equipment used in other areas such as service bays, sales areas, Storage and restrooms must comply with Article 514 Table 514-3(B)(1). The service bays and adjacent areas not cut off by walls would need to comply with Article 511 and may be unclassified by “special permission”. Other rooms outside the Class I area that are properly cut off by walls would be unclassified.

The use of arc-producing equipment less than 12 feet above a Class I location if the enclosure is capable of containing sparks or hot metal particles is permitted [Section 511.7(B)].

(C) Motor Fuel Dispensing Stations in Boatyards and Marinas.

(1) General. Electrical wiring and equipment located at or serving motor fuel dispensing locations shall be installed on the side of the wharf, pier, or dock opposite from the liquid piping system.

Informational Note: For additional information, see NFPA 303-2011, *Fire Protection Standard for Marinas and Boatyards*, and NFPA 30A-2012, *Motor Fuel Dispensing Facilities and Repair Garages*.

(2) Classification of Class I, Division 1 and 2 Areas. The following

INTERPRETATION OF ARTICLE 514: MOTOR FUEL DISPENSING FACILITIES

Table 514.3(B)(1) Class I Locations — Motor Fuel Dispensing Facilities

Location	Division (Group D)	Zone (Group IIA)	Extent of Classified Location ¹
Dispensing Device (except Overhead Type)^{2,3}			
Under dispenser containment	1	1	Entire space within and under dispenser pit or containment
Dispenser	2	2	Within 450 mm (18 in.) of dispenser enclosure or that portion of dispenser enclosure containing liquid handling components, extending horizontally in all directions and down to grade level
Outdoor	2	2	Up to 450 mm (18 in.) above grade level, extending 6 m (20 ft) horizontally in all directions from dispenser enclosure
Indoor			
- with mechanical ventilation	2	2	Up to 450 mm (18 in.) above floor level, extending 6 m (20 ft) horizontally in all directions from dispenser enclosure
- with gravity ventilation	2	2	Up to 450 mm (18 in.) above floor level, extending 7.5 m (25 ft) horizontally in all directions from dispenser enclosure
Dispensing Device — Overhead Type⁴			
	1	1	Space within dispenser enclosure and all electrical equipment integral with dispensing hose or nozzle
	2	2	Within 450 mm (18 in.) of dispenser enclosure, extending horizontally in all directions and down to grade level
	2	2	Up to 450 mm (18 in.) above grade level, extending 6 m (20 ft) horizontally in all directions from a point vertically below edge of dispenser enclosure
Remote Pump —			
Outdoor	1	1	Entire space within any pit or box below grade level, any part of which is within 3 m (10 ft) horizontally from any edge of pump
	2	2	Within 900 mm (3 ft) of any edge of pump, extending horizontally in all directions
	2	2	Up to 450 mm (18 in.) above grade level, extending 3 m (10 ft) horizontally in all directions from any edge of pump
Indoor	1	1	Entire space within any pit
	2	2	Within 1.5 m (5 ft) of any edge of pump, extending in all directions
	2	2	Up to 900 mm (3 ft) above floor level, extending 7.5 m (25 ft) horizontally in all directions from any edge of pump
Sales, Storage, Rest Rooms including structures (such as the attendant's kiosk) on or adjacent to dispensers			
	unclassified	unclassified	Except as noted below
	1	1	Entire volume, if there is any opening to room within the extent of a Division 1 or Zone 1 location
	2	2	Entire volume, if there is any opening to room within the extent of a Division 2 or Zone 2 location
Tank, Aboveground			
Inside tank	1	0	Entire inside volume
Shell, ends, roof, dike area	1	1	Entire space within dike, where dike height exceeds distance from tank shell to inside of dike wall for more than 50 percent of tank circumference
	2	2	Entire space within dike, where dike height does not exceed distance from tank shell to inside of dike wall for more than 50 percent of tank circumference
Vent	2	2	Within 3 m (10 ft) of shell, ends, or roof of tank
	1	1	Within 1.5 m (5 ft) of open end of vent, extending in all directions
	2	2	Between 1.5 m and 3 m (5 ft and 10 ft) from open end of vent, extending in all directions

¹For marine application, grade level means the surface of a pier, extending down to water level.

²Refer to Figure 514.3(a) and Figure 514.3(b) for an illustration of classified location around dispensing devices.

³Area classification inside the dispenser enclosure is covered in UL 87, *Standard for Power-Operated Dispensing Devices for Petroleum Products*.

⁴Ceiling-mounted hose reel. [30A: Table 8.3.1]

INTERPRETATION OF ARTICLE 514: MOTOR FUEL DISPENSING FACILITIES

Table 514.3(B)(1) Class I Locations — Motor Fuel Dispensing Facilities — Continued

Location	Division (Group D)	Zone (Group IIA)	Extent of Classified Location ¹
Tank, Underground			
Inside tank	1	0	Entire inside volume
Fill Opening	1	1	Entire space within any pit or box below grade level, any part of which is within a Division 1 or Division 2 classified location or within a Zone 1 or Zone 2 classified location
	2	2	Up to 450 mm (18 in.) above grade level, extending 1.5 m (5 ft) horizontally in all directions from any tight-fill connection and extending 3 m (10 ft) horizontally in all directions from any loose-fill connection
Vent	1	1	Within 1.5 m (5 ft) of open end of vent, extending in all directions
	2	2	Between 1.5 m and 3 m (5 ft and 10 ft) from open end of vent, extending in all directions
Vapor Processing System			
Pits	1	1	Entire space within any pit or box below grade level, any part of which: (1) is within a Division 1 or Division 2 classified location; (2) is within a Zone 1 or Zone 2 classified location; (3) houses any equipment used to transfer or process vapors
Equipment in protective enclosures	2	2	Entire space within enclosure
Equipment <i>not</i> within protective enclosure	2	2	Within 450 mm (18 in.) of equipment containing flammable vapors or liquid, extending horizontally in all directions and down to grade level
	2	2	Up to 450 mm (18 in.) above grade level within 3 m (10 ft) horizontally of the vapor processing equipment
- Equipment enclosure	1	1	Entire space within enclosure, if flammable vapor or liquid is present under normal operating conditions
	2	2	Entire space within enclosure, if flammable vapor or liquid is not present under normal operating conditions
- Vacuum assist blower	2	2	Within 450 mm (18 in.) of blower, extending horizontally in all directions and down to grade level
	2	2	Up to 450 mm (18 in.) above grade level, extending 3 m (10 ft) horizontally in all directions
Vault	1	1	Entire interior space, if Class I liquids are stored within

¹For marine application, grade level means the surface of a pier, extending down to water level.

²Refer to Figure 514.3(a) and Figure 514.3(b) for an illustration of classified location around dispensing devices.

³Area classification inside the dispenser enclosure is covered in UL 87, *Standard for Power-Operated Dispensing Devices for Petroleum Products*.

⁴Ceiling-mounted hose reel. [30A: Table 8.3.1]

criteria shall be used for the purposes of applying Table 514.3(B)(1) and Table 514.3(B)(2) to motor fuel dispensing equipment on floating or fixed piers, wharfs, or docks.

(D) Closed Construction. Where the construction of floating docks, piers, or wharfs is closed so that there is no space between the bottom of the dock, pier, or wharf and the water, as in the case of concrete-enclosed expanded foam or similar construction, and the construction includes integral service boxes with supply chases, the following shall apply:

(1) The space above the surface of the floating dock, pier, or wharf shall be a Class I, Division 2 location with distances as specified in Table 514.3(B)(1) for dispenser and outdoor locations.

(2) Spaces below the surface of the floating dock, pier, or wharf that have areas or enclosures, such as tubs, voids, pits, vaults, boxes, depressions, fuel piping chases, or similar spaces, where flammable liquid or vapor can accumulate shall be a Class I, Division 1 location.

Exception No. 1: Dock, pier, or wharf sections that do not support fuel

dispensers and abut, but are located 6.0 m (20 ft) or more from, dock sections that support a fuel dispenser(s) shall be permitted to be Class I, Division 2 locations where documented air space is provided between dock sections to allow flammable liquids or vapors to dissipate without traveling to such dock sections. The documentation shall comply with 500.4(A).

Exception No. 2: Dock, pier, or wharf sections that do not support fuel dispensers and do not directly abut sections that support fuel dispensers shall be permitted to be unclassified where documented air space is provided and where flammable liquids or vapors cannot travel to such dock sections. The documentation shall comply with 500.4(A).

(E) Open Construction. Where the construction of piers, wharfs, or docks is open, as in the case of decks built on stringers supported by pilings, floats, pontoons, or similar construction, the following shall apply:

(1) The area 450 mm (18 in.) above the surface of the dock, pier, or wharf and extending 6.0 m (20 ft) horizontally in all directions from the outside edge of the dispenser and down to the water level shall be a Class 1, Division 2 location.

INTERPRETATION OF ARTICLE 514: MOTOR FUEL DISPENSING FACILITIES

Table 514.3(B)(2) Electrical Equipment Classified Areas for Dispensing Devices

Dispensing Device	Extent of Classified Area	
	Class I, Division 1	Class I, Division 2
Compressed natural gas	Entire space within the dispenser enclosure	1.5 m (5 ft) in all directions from dispenser enclosure
Liquefied natural gas	Entire space within the dispenser enclosure and 1.5 m (5 ft) in all directions from the dispenser enclosure	From 1.5 m to 3.0 m (5 ft to 10 ft) in all directions from the dispenser enclosure
Liquefied petroleum gas	Entire space within the dispenser enclosure; 450 mm (18 in.) from the exterior surface of the dispenser enclosure to an elevation of 1.2 m (4 ft) above the base of the dispenser; the entire pit or open space beneath the dispenser and within 6.0 m (20 ft) horizontally from any edge of the dispenser when the pit or trench is not mechanically ventilated.	Up to 450 mm (18 in.) aboveground and within 6.0 m (20 ft) horizontally from any edge of the dispenser enclosure, including pits or trenches within this area when provided with

(2) Enclosures such as tubs, voids, pits, vaults, boxes, depressions, piping chases, or similar spaces where flammable liquids or vapors can accumulate within 6.0 m (20 ft) of the dispenser shall be a Class I, Division 1 location.

Section 514.3(C) was relocated from Section 555.21

514.4 Wiring and Equipment Installed in Class I Locations. All electrical equipment and wiring installed in Class I locations as classified in 514.3 shall comply with the applicable provisions of Article 501.

Exception: As permitted in 514.8.

Informational Note: For special requirements for conductor insulation, see 501.20.

Requirements are somewhat different than for indoor pumps, as liquids dispensed are not typically gasoline.

Table 514.3(B)(1) gives requirements for a lubrication or service room where no dispensing takes place. An unventilated pit in such an area has been determined to be Class I, Division 2. The area is unclassified when ventilated in accordance with NFPA 30A, Section 5-3.1.

Flammable liquids shall be known as Class I liquids. Class I liquids are divided into three classes as follows:

Class IA shall include liquids having flash points below 73°F (22.8°C) and having a boiling point below 100°F (37.8°C).

Class IB shall include liquids having flash points below 73°F (22.8°C) and having a boiling point at or above 100°F (37.8°C).

Class IC shall include liquids having flash points at or above 73°F (22.8°C) and having a boiling point below 100°F (37.8°C).

It should be mentioned that flash point was selected as the basis for classification of flammable and combustible liquids because it is directly related to a liquid's ability to generate vapor, i.e., its volatility. Since it is the vapor of the liquid, not the liquid itself that burns, vapor generation becomes the primary factor in determining the fire hazard. The expression "low flash - high hazard" applies. Liquids having flash points below ambient storage temperatures generally display a rapid rate of flame spread over the surface of the liquid, since it is not necessary for the heat of the fire to expend its energy in heating the liquid to generate more vapor.

VAPOR PROCESSING EQUIPMENT NOT WITHIN PROTECTIVE ENCLOSURES AND VACUUM ASSIST BLOWERS.

For "Vapor Processing Equipment Located Within Protective Enclosures," see NFPA 30A, Code for Motor Fuel Dispensing Facilities and Repair Garages, Section 10.1. Any of the equipment within the protective enclosure is Class I, Division 2, Group D.

514.7 Wiring and Equipment Above Class I Locations. Wiring and equipment above the Class I locations as classified in 514.3 shall comply with 511.7.

514.8 Underground Wiring. Underground wiring shall be installed in threaded rigid metal conduit or threaded steel intermediate metal conduit. Any portion of electrical wiring that is below the surface of a Class I, Division 1, or a Class I, Division 2, location [as classified in Table 514.3(B)(1) and Table 514.3(B)(2)] shall be sealed within 3.05 m (10 ft) of the point of emergence above grade. Except for listed explosionproof reducers at the conduit seal, there shall be no union, coupling, box, or fitting between the conduit seal and the point of emergence above grade. Refer to Table 300.5.

Exception No. 1: Type MI cable shall be permitted where it is installed in accordance with Article 332.

Exception No. 2: Type PVC conduit and Type RTRC conduit shall be permitted where buried under not less than 600 mm (2 ft) of cover. Where Type PVC conduit or Type RTRC conduit is used, threaded rigid metal conduit or threaded steel intermediate metal conduit shall be used for the last 600 mm (2 ft) of the underground run to emergence or to the point of connection to the aboveground raceway, and an equipment grounding conductor shall be included to provide electrical continuity of the raceway system and for grounding of non-current-carrying metal parts.

Section 514.8 prohibits joints between where a conduit emerges from the grade and the conduit seal, except for listed reducers. In addition, the seal must be within 10 ft of the point of emergence from grade. The section now specifies what specific types of rigid nonmetallic conduit are permissible.

514.9 Sealing.

(A) At Dispenser. A listed seal shall be provided in each conduit run entering or leaving a dispenser or any cavities or enclosures in direct communication therewith. The sealing fitting shall be the first fitting after the conduit emerges from the earth or concrete.

INTERPRETATION OF ARTICLE 514: MOTOR FUEL DISPENSING FACILITIES

(B) At Boundary. Additional seals shall be provided in accordance with 501.15. Sections 501.15(A)(4) and (B)(2) shall apply to horizontal as well as to vertical boundaries of the defined Class I locations.

514.11 Circuit Disconnects.

(A) General. Each circuit leading to or through dispensing equipment, including all associated power, communications, data, and video circuits, and equipment for remote pumping systems, shall be provided with a clearly identified and readily accessible switch or other approved means, located remote from the dispensing devices, to disconnect simultaneously from the source of supply, all conductors of the circuits, including the grounded conductor, if any.

Single-pole breakers utilizing handle ties shall not be permitted.

(B) Attended Self-Service Motor Fuel Dispensing Facilities. Emergency controls as specified in 514.11(A) shall be installed at a location acceptable to the authority having jurisdiction, but controls shall not be more than 30 m (100 ft) from dispensers. [30A:6.7.1]

(C) Unattended Self-Service Motor Fuel Dispensing Facilities. Emergency controls as specified in 514.11(A) shall be installed at a location acceptable to the authority having jurisdiction, but the control shall be more than 6 m (20 ft) but less than 30 m (100 ft) from the dispensers. Additional emergency controls shall be installed on each group of dispensers or the outdoor equipment used to control the dispensers. Emergency controls shall shut off all power to all dispensing equipment at the station. Controls shall be manually reset only in a manner approved by the authority having jurisdiction. [30A:6.7.2]

Informational Note: For additional information, see 6.7.1 and 6.7.2 of NFPA 30A-2012, *Code for Motor Fuel Dispensing Facilities and Repair Garages*.

514.13 Provisions for Maintenance and Service of Dispensing Equipment. Each dispensing device shall be provided with a means to remove all external voltage sources, including power, communications, data, and video circuits and including feedback, during periods of maintenance and service of the dispensing equipment. The location of this means shall be permitted to be other than inside or adjacent to the dispensing device. The means shall be capable of being locked in the open position in accordance with 110.25.

Section 514.13 requires a lock out means to remove all voltages from dispensing equipment during service and maintenance. The section specifies all of the types of circuits that are required to have provisions that remove all voltage sources to the dispensing device during maintenance and service operations. Section 110.25 was added to consolidate requirements for disconnecting means that are capable of being locked in the open position. This is intended to also address those circuits that are other than power circuits.

514.16 Grounding and Bonding. All metal raceways, the metal armor or metallic sheath on cables, and all non-current-carrying metal parts of fixed and portable electrical equipment, regardless of voltage, shall be grounded and bonded. Grounding and bonding in Class I locations shall comply with 501.30.

INTERPRETATION OF ARTICLE 515: BULK STORAGE PLANTS

CHANGES TO ARTICLE 515

There were no significant revisions made to Article 515 for the 2014 Code. The changes that were made are editorial in nature.

Informational Note: Text that is followed by a reference in brackets has been extracted from NFPA 30-2012, *Flammable and Combustible Liquids Code*. Only editorial changes were made to the extracted text to make it consistent with this Code.

515.1 Scope. This article covers a property or portion of a property where flammable liquids are received by tank vessel, pipelines, tank car, or tank vehicle and are stored or blended in bulk for the purpose of distributing such liquids by tank vessel, pipeline, tank car, tank vehicle, portable tank, or container.

515.3 Class I Locations. Table 515.3 shall be applied where Class I liquids are stored, handled, or dispensed and shall be used to delineate and classify bulk storage plants. The class location shall not extend beyond a floor, wall, roof, or other solid partition that has no communicating openings. [30:8.1, 8.2.2]

Informational Note No. 1: The area classifications listed in Table 515.3 are based on the premise that the installation meets the applicable requirements of NFPA 30-2012, *Flammable and Combustible Liquids Code*, Chapter 5, in all respects. Should this not be the case, the authority having jurisdiction has the authority to classify the extent of the classified space.

Informational Note No. 2: See 555.21 for gasoline dispensing stations in marinas and boatyards.

515.4 Wiring and Equipment Located in Class I Locations. All electrical wiring and equipment within the Class I locations defined

in 515.3 shall comply with the applicable provisions of Article 501 or Article 505 for the division or zone in which they are used.

Exception: As permitted in 515.8.

Section 555.21 was relocated to Section 514.3(C).

515.7 Wiring and Equipment Above Class I Locations.

(A) Fixed Wiring. All fixed wiring above Class I locations shall be in metal raceways, Schedule 80 PVC conduit, Type RTRC marked with the suffix -XW, or Type MI, Type TC, or Type MC cable, or Type PLTC and Type PLTC-ER cable in accordance with the provisions of Article 725, including installation in cable tray systems or Type ITC and Type ITC-ER cable as permitted in 727.4. The cable shall be terminated with listed fittings.

(B) Fixed Equipment. Fixed equipment that may produce arcs, sparks, or particles of hot metal, such as lamps and lampholders for fixed lighting, cutouts, switches, receptacles, motors, or other equipment having make-and-break or sliding contacts, shall be of the totally enclosed type or be constructed so as to prevent the escape of sparks or hot metal particles.

(C) Portable Luminaires or Other Utilization Equipment. Portable luminaires or other utilization equipment and their flexible cords shall comply with the provisions of Article 501 or Article 505 for the class of location above which they are connected or used.

515.8 Underground Wiring.

(A) Wiring Method. Underground wiring shall be installed in threaded rigid metal conduit or threaded steel intermediate metal conduit or, where buried under not less than 600 mm (2 ft) of cover, shall be

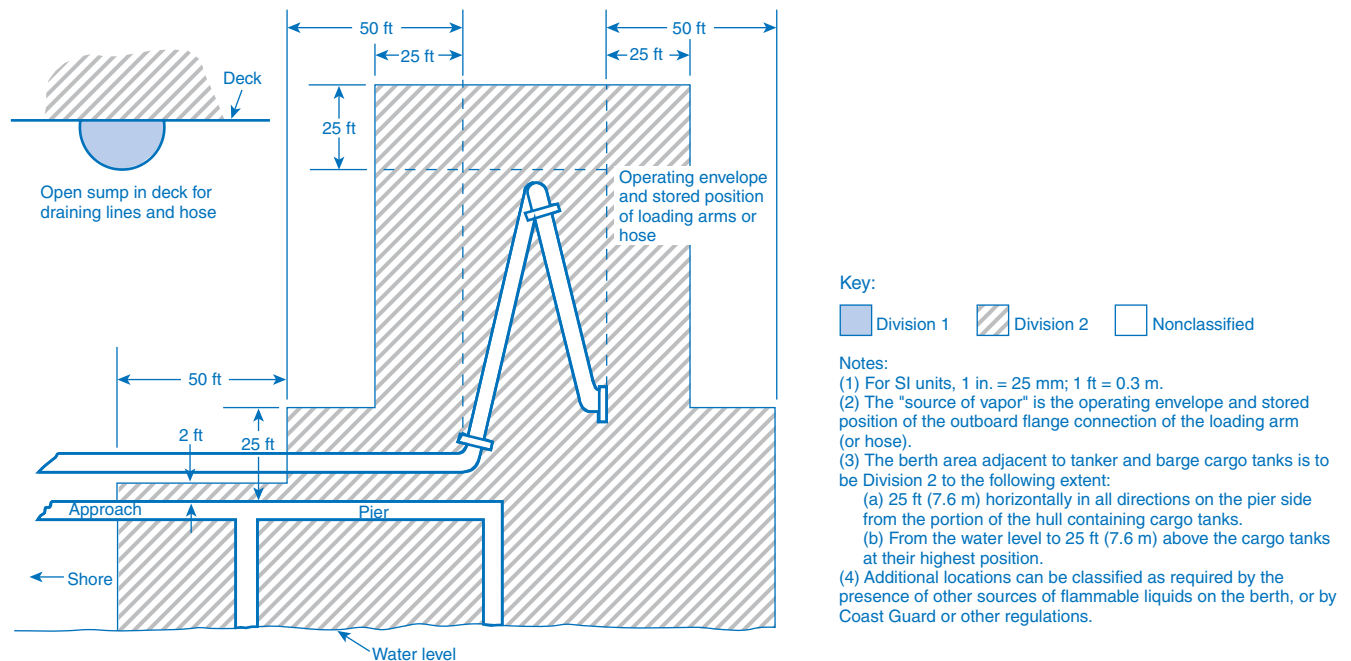

Figure 515.3 Marine Terminal Handling Flammable Liquids. [30:Figure 29.3.22]

INTERPRETATION OF ARTICLE 515: BULK STORAGE PLANTS

Table 515.3 Electrical Area Classifications

Location	NEC Class I Division	Zone	Extent of Classified Area
Indoor equipment installed in accordance with Section 5.3 of NFPA 30 where flammable vapor–air mixtures can exist under normal operation	1	0	The entire area associated with such equipment where flammable gases or vapors are present continuously or for long periods of time
	1	1	Area within 1.5 m (5 ft) of any edge of such equipment, extending in all directions
	2	2	Area between 1.5 m and 2.5 m (5 ft and 8 ft) of any edge of such equipment, extending in all directions; also, space up to 900 mm (3 ft) above floor or grade level within 1.5 m to 7.5 m (5 ft to 25 ft) horizontally from any edge of such equipment ¹
Outdoor equipment of the type covered in Section 5.3 of NFPA 30 where flammable vapor–air mixtures may exist under normal operation	1	0	The entire area associated with such equipment where flammable gases or vapors are present continuously or for long periods of time
	1	1	Area within 900 mm (3 ft) of any edge of such equipment, extending in all directions
	2	2	Area between 900 mm (3 ft) and 2.5 m (8 ft) of any edge of such equipment, extending in all directions; also, space up to 900 mm (3 ft) above floor or grade level within 900 mm to 3.0 m (3 ft to 10 ft) horizontally from any edge of such equipment
Tank storage installations inside buildings	1	1	All equipment located below grade level
	2	2	Any equipment located at or above grade level
Tank – aboveground	1	0	Inside fixed roof tank
	1	1	Area inside dike where dike height is greater than the distance from the tank to the dike for more than 50 percent of the tank circumference
Shell, ends, or roof and dike area	2	2	Within 3.0 m (10 ft) from shell, ends, or roof of tank; also, area inside dike to level of top of dike wall
Vent	1	0	Area inside of vent piping or opening
	1	1	Within 1.5 m (5 ft) of open end of vent, extending in all directions
	2	2	Area between 1.5 m and 3.0 m (5 ft and 10 ft) from open end of vent, extending in all directions
Floating roof with fixed outer roof	1	0	Area between the floating and fixed roof sections and within the shell
Floating roof with no fixed outer roof	1	1	Area above the floating roof and within the shell
Underground tank fill opening	1	1	Any pit, or space below grade level, if any part is within a Division 1 or 2, or Zone 1 or 2, classified location
	2	2	Up to 450 mm (18 in.) above grade level within a horizontal radius of 3.0 m (10 ft) from a loose fill connection, and within a horizontal radius of 1.5 m (5 ft) from a tight fill connection
Vent – discharging upward	1	0	Area inside of vent piping or opening
	1	1	Within 900 mm (3 ft) of open end of vent, extending in all directions
	2	2	Area between 900 mm and 1.5 m (3 ft and 5 ft) of open end of vent, extending in all directions
Drum and container filling – outdoors or indoors	1	0	Area inside the drum or container
	1	1	Within 900 mm (3 ft) of vent and fill openings, extending in all directions
	2	2	Area between 900 mm and 1.5 m (3 ft and 5 ft) from vent or fill opening, extending in all directions; also, up to 450 mm (18 in.) above floor or grade level within a horizontal radius of 3.0 m (10 ft) from vent or fill opening
Pumps, bleeders, withdrawal fittings			
Indoors	2	2	Within 1.5 m (5 ft) of any edge of such devices, extending in all directions; also, up to 900 mm (3 ft) above floor or grade level within 7.5 m (25 ft) horizontally from any edge of such devices
Outdoors	2	2	Within 900 mm (3 ft) of any edge of such devices, extending in all directions. Also, up to 450 mm (18 in.) above grade level within 3.0 m (10 ft) horizontally from any edge of such devices

¹The release of Class I liquids may generate vapors to the extent that the entire building, and possibly an area surrounding it, should be considered a Class I, Division 2 or Zone 2 location.

²When classifying extent of area, consideration shall be given to fact that tank cars or tank vehicles may be spotted at varying points. Therefore, the extremities of the loading or unloading positions shall be used. [30: Table 8.2.2]

INTERPRETATION OF ARTICLE 515: BULK STORAGE PLANTS

Table 515.3 Electrical Area Classifications — Continued

Location	NEC Class I Division	Zone	Extent of Classified Area
Pits and sumps			
Without mechanical ventilation	1	1	Entire area within a pit or sump if any part is within a Division 1 or 2, or Zone 1 or 2, classified location
With adequate mechanical ventilation	2	2	Entire area within a pit or sump if any part is within a Division 1 or 2, or Zone 1 or 2, classified location
Containing valves, fittings, or piping, and not within a Division 1 or 2, or Zone 1 or 2, classified location	2	2	Entire pit or sump
Drainage ditches, separators, impounding basins			
Outdoors	2	2	Area up to 450 mm (18 in.) above ditch, separator, or basin; also, area up to 450 mm (18 in.) above grade within 4.5 m (15 ft) horizontally from any edge
Indoors			Same classified area as pits
Tank vehicle and tank car ² loading through open dome	1	0	Area inside of the tank
	1	1	Within 900 mm (3 ft) of edge of dome, extending in all directions
	2	2	Area between 900 mm and 4.5 m (3 ft and 15 ft) from edge of dome, extending in all directions
Loading through bottom connections with atmospheric venting	1	0	Area inside of the tank
	1	1	Within 900 mm (3 ft) of point of venting to atmosphere, extending in all directions
	2	2	Area between 900 mm and 4.5 m (3 ft and 15 ft) from point of venting to atmosphere, extending in all directions; also, up to 450 mm (18 in.) above grade within a horizontal radius of 3.0 m (10 ft) from point of loading connection
Office and rest rooms	Unclassified		If there is any opening to these rooms within the extent of an indoor classified location, the room shall be classified the same as if the wall, curb, or partition did not exist.
Loading through closed dome with atmospheric venting	1	1	Within 900 mm (3 ft) of open end of vent, extending in all directions
	2	2	Area between 900 mm and 4.5 m (3 ft and 15 ft) from open end of vent, extending in all directions; also, within 900 mm (3 ft) of edge of dome, extending in all directions
Loading through closed dome with vapor control	2	2	Within 900 mm (3 ft) of point of connection of both fill and vapor lines extending in all directions
Bottom loading with vapor control or any bottom unloading	2	2	Within 900 mm (3 ft) of point of connections, extending in all directions; also up to 450 mm (18 in.) above grade within a horizontal radius of 3.0 m (10 ft) from point of connections
Storage and repair garage for tank vehicles	1	1	All pits or spaces below floor level
	2	2	Area up to 450 mm (18 in.) above floor or
Garages for other than tank vehicles	Unclassified		If there is any opening to these rooms within the extent of an outdoor classified location, the entire room shall be classified the same as the area classification at the point of the opening.
Outdoor drum storage	Unclassified		
Inside rooms or storage lockers used for the storage of Class I liquids	2	2	Entire room
Indoor warehousing where there is no flammable liquid transfer	Unclassified		If there is any opening to these rooms within the extent of an indoor classified location, the room shall be classified the same as if the wall, curb, or partition did not exist.
Piers and wharves			See Figure 515.3.

¹The release of Class I liquids may generate vapors to the extent that the entire building, and possibly an area surrounding it, should be considered a Class I, Division 2 or Zone 2 location.

²When classifying extent of area, consideration shall be given to fact that tank cars or tank vehicles may be spotted at varying points. Therefore, the extremities of the loading or unloading positions shall be used. [30: Table 8.2.2]

INTERPRETATION OF ARTICLE 515: BULK STORAGE PLANTS

permitted in Type PVC conduit, Type RTRC conduit, or a listed cable. Where Type PVC conduit or Type RTRC conduit is used, threaded rigid metal conduit or threaded steel intermediate metal conduit shall be used for not less than the last 600 mm (2 ft) of the conduit run to the conduit point of emergence from the underground location or to the point of connection to an aboveground raceway. Where cable is used, it shall be enclosed in threaded rigid metal conduit or threaded steel intermediate metal conduit from the point of lowest buried cable level to the point of connection to the aboveground raceway.

(B) Insulation. Conductor insulation shall comply with 501.20.

(C) Nonmetallic Wiring. Where Type PVC conduit, Type RTRC conduit, or cable with a nonmetallic sheath is used, an equipment grounding conductor shall be included to provide for electrical continuity of the raceway system and for grounding of non-current-carrying metal parts.

515.9 Sealing. Sealing requirements shall apply to horizontal as well as to vertical boundaries of the defined Class I locations. Buried raceways and cables under defined Class I locations shall be considered to be within a Class I, Division 1 or Zone 1 location.

515.10 Special Equipment — Gasoline Dispensers. Where gasoline or other volatile flammable liquids or liquefied flammable gases are dispensed at bulk stations, the applicable provisions of Article 514 shall apply.

515.16 Grounding and Bonding. All metal raceways, the metal armor or metallic sheath on cables, and all non-current-carrying metal parts of fixed or portable electrical equipment, regardless of voltage, shall be grounded and bonded as provided in Article 250.

Grounding and bonding in Class I locations shall comply with 501.30 for Class I, Division 1 and 2 locations and 505.25 for Class I, Zone 0, 1, and 2 locations.

Informational Note: For information on grounding for static protection, see 4.5.3.4 and 4.5.3.5 of NFPA 30-2012, *Flammable and Combustible Liquids Code*.

STATIC ELECTRICITY.

Static electricity can build up to dangerous levels. Shown here are two safe ways to discharge static electricity with Appleton products.

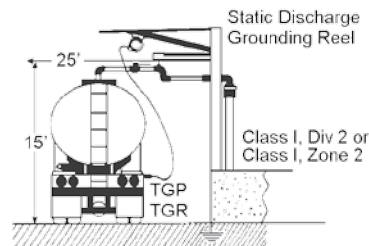

GROUNDING REEL INSTALLED ON BUILDING. HERE TGR PLUG REPLACES ALLIGATOR CLIP FURNISHED AS STANDARD WITH REEL.

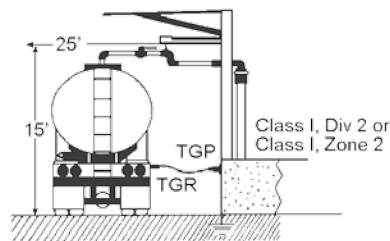

TGP STUDS AND TGR PLUG USED AT GASOLINE BULK STATION. STUDS PERMANENTLY INSTALLED ON TRUCK AND BUILDING.



TGP GROUNDING STUD AND TGR GROUNDING PLUG



STATIC DISCHARGE GROUNDING REEL

Grounding Reel installed on building. Here TGR Plug replaces alligator clip furnished as standard with reel. TGP Studs and TGR Plug used at gasoline bulk station. Studs permanently installed on truck and building. TGP Grounding Static Discharge Stud and TGR Grounding Reel Grounding Plug

INTERPRETATION OF ARTICLE 515: BULK STORAGE PLANTS



BULK PLANT OR TERMINAL. *NEC*® SECTION 515.1 DEFINES SUCH A PLANT AS A LOCATION “WHERE FLAMMABLE LIQUIDS ARE RECEIVED AND ARE STORED OR BLENDED IN BULK FOR THE PURPOSE OF DISTRIBUTING SUCH LIQUIDS BY TANK VESSEL,” ETC.



TYPICALLY, PRODUCTS FROM BULK STORAGE PLANTS ARE DISTRIBUTED BY TANK TRUCKS.

NOTES:

INTERPRETATION OF ARTICLE 516: SPRAY APPLICATION, DIPPING, AND COATING PROCESSES

CHANGES TO ARTICLE 516

The following Article 516 sections have been revised during the 2014 *NEC*® Code cycle. These changes are those that are substantive and should be noted. This list does not include those changes that are editorial in nature.

Underlined text indicates a section that has been revised from the previous *NEC*® edition. It is not intended to indicate legislation text detailing the word-for-word revisions to the section. Where minor revisions have been made to a section, these will include underlined text for select words to indicate the minor revision.

- **Throughout Article 516:**

Multiple revisions were made to correspond with revisions to NFPA 33 and NFPA 34.

Informational Note: Text that is followed by a reference in brackets has been extracted from NFPA 33-2011, *Standard for Spray Application Using Flammable and Combustible Materials*, or NFPA 34-2011, *Standard for Dipping, Coating, and Printing Processes Using Flammable or Combustible Liquids*. Only editorial changes were made to the extracted text to make it consistent with this *Code*.

516.1 Scope. This article covers the regular or frequent application of flammable liquids, combustible liquids, and combustible powders by spray operations and the application of flammable liquids, or combustible liquids at temperatures above their flashpoint, by dipping, coating, or other means.

Informational Note: For further information regarding safeguards for these processes, such as fire protection, posting of warning signs, and maintenance, see NFPA 33-2011, *Standard for Spray Application Using Flammable and Combustible Materials*, and NFPA 34-2011, *Standard for Dipping and Coating Processes Using Flammable or Combustible Liquids*. For additional information regarding ventilation, see NFPA 91-2011, *Standard for Exhaust Systems for Air Conveying of Vapors, Gases, Mists, and Noncombustible Particulate Solids*.

516.2 Definitions. For the purpose of this article, the following definitions shall apply.

Flash-Off Area. An open or enclosed area after a spray application process where vapors are released due to exposure to ambient air or a heated atmosphere. [33:3.3.1.1]

Limited Finishing Workstation. An apparatus that is capable of confining the vapors, mists, residues, dusts, or deposits that are generated by a spray application process and that meets the requirements of Section 14.3 of NFPA 33, *Standard for Spray Application Using Flammable or Combustible Materials*, but does not meet the requirements of a spray booth or spray room, as herein defined. [33:3.3.15.1]

Resin Application Area. Any area in which polyester resins or gelcoats are spray applied. [33:3.3.1.2]

Spray Area. Any fully enclosed, partly enclosed, or unenclosed area in which ignitable quantities of flammable or combustible vapors, mists, residues, dusts, or deposits are present due to the operation of spray processes, including (1) any area in the direct path of a spray application process; (2) the interior of a spray booth or spray room or limited finishing workstation, as herein defined; (3) the interior of any exhaust plenum, eliminator section, or scrubber section; (4) the interior of any exhaust duct or exhaust stack leading from a spray application process; (5) the interior of any air recirculation filter house or enclosure, including secondary recirculation particulate filters; (6) any solvent concentrator (pollution abatement) unit or solvent

recovery (distillation) unit. The following are not considered to be a part of the spray area: (1) fresh air make-up units; (2) air supply ducts and air supply plenums; (3) recirculation air supply ducts downstream of secondary filters; (4) exhaust ducts from solvent concentrator (pollution abatement) units. [33:3.3.2.3]

Informational Note: Unenclosed spray areas are locations outside of buildings or are localized operations within a larger room or space. Such are normally provided with some local vapor extraction/ventilation system. In automated operations, the area limits are the maximum area in the direct path of spray operations. In manual operations, the area limits are the maximum area of spray when aimed at 90 degrees to the application surface.

Spray Booth. A power-ventilated enclosure for a spray application operation or process that confines and limits the escape of the material being sprayed, including vapors, mists, dusts, and residues that are produced by the spraying operation and conducts or directs these materials to an exhaust system. [33:3.3.14]

Informational Note: A spray booth is an enclosure or insert within a larger room used for spray/coating/dipping applications. A spray booth may be fully enclosed or have open front or face and may include a separate conveyor entrance and exit. The spray booth is provided with a dedicated ventilation exhaust but may draw supply air from the larger room or have a dedicated air supply.

Spray Room. A power-ventilated fully enclosed room used exclusively for open spraying of flammable or combustible materials. A spray room is a purposefully enclosed room built for spray/coating/dipping applications provided with dedicated ventilation supply and exhaust. Normally the room is configured to house the item to be painted, providing reasonable access around the item/process. Depending on the size of the item being painted, such rooms may actually be the entire building or the major portion thereof. [33:3.3.15]

The Appleton APL Fluorescent Luminaire is suitable for use in paint spray areas as defined in *NEC*® Section 516.2. Light is concentrated in two lamps (not furnished with fixture) in just a 2 foot width. Its compact size makes it ideal in areas where there is restricted mounting space.

The PAPL Portable Fluorescent Luminaire is designed for use directly inside a paint spray booth, complying with *NEC*® Section 516.3(B) and NFPA 33-2003. Available in two and four lamp units. UL Listed for horizontal use only.

Unenclosed Spray Area. Any spray area that is not confined by a limited finishing workstation, spray booth, or spray room, as herein defined. [33:3.3.2.3.2].

Subsection 516.3(A)(1)a was added by a tentative interim amendment (TIA). See page 1.

Reference to page 1 in the TIA note is to page 1 of NFPA 70.

516.3 Classification of Locations. Classification is based on dangerous quantities of flammable vapors, combustible mists, residues, dusts, or deposits that are present or might be present in quantities sufficient to produce ignitable or explosive mixtures with air.

(A) Zone Classification of Locations.

(1) For the purposes of this article, the zone system of electrical area classification shall be applied as follows:

INTERPRETATION OF ARTICLE 516: SPRAY APPLICATION, DIPPING, AND COATING PROCESSES

THE APPLETON EFU FLOURESCENT LUMINAIRES ARE NOT ONLY APPROVED FOR USE IN CLASS I AND II, DIVISIONS 1 AND 2 LOCATIONS, BUT ALSO WITHIN PAINT SPRAY BOOTHS WHERE THE LUMINAIRES ARE SUBJECT TO READILY IGNITIBLE DEPOSITS OF RESIDUES OR MATERIALS THAT ARE FLAMMABLE OR COMBUSTIBLE.

EFU/APL SERIES AND PAPL SERIES SUITABLE FOR USE IN PAINT SPRAY AREAS.



EFU/APL SERIES



PAPL SERIES

a. The inside of open or closed containers or vessels shall be considered a Class I, Zone 0 location.

b. A Class I, Division 1 location shall be permitted to be alternatively classified as a Class I, Zone 1 location.

c. A Class I, Division 2 location shall be permitted to be alternatively classified as a Class I, Zone 2 location.

d. A Class II, Division 1 location shall be permitted to be alternatively classified as a Zone 21 location.

e. A Class II, Division 2 location shall be permitted to be alternatively classified as a Zone 22 location. [33:6.2.2]

(2) For the purposes of electrical area classification, the division system and the zone system shall not be intermixed for any given source of release. [33:6.2.3]

(3) In instances of areas within the same facility classified separately, Class I, Zone 2 locations shall be permitted to abut, but not overlap, Class I, Division 2 locations. Class I, Zone 0 or Zone 1 locations shall not abut Class I, Division 1 or Division 2 locations. [33:6.2.4]

(4) Open flames, spark-producing equipment or processes, and equipment whose exposed surfaces exceed the autoignition temperature of the material being sprayed shall not be located in a spray area or in any surrounding area that is classified as Division 2, Zone 2, or Zone 22.

Exception: This requirement shall not apply to drying, curing, or fusing apparatus. [33:6.2.5]

(5) Any utilization equipment or apparatus that is capable of producing sparks or particles of hot metal and that is located above or adjacent to either the spray area or the surrounding Division 2, Zone

2, or Zone 22 areas shall be of the totally enclosed type or shall be constructed to prevent the escape of sparks or particles of hot metal. [33:6.2.6].

(B) Class I, Division 1 or Class I, Zone 0 Locations. The following spaces shall be considered Class I, Division 1, or Class I, Zone 0, as applicable:

(1) The interior of any open or closed container of a flammable liquid

(2) The interior of any dip tank or coating tank

(3) The interior of any ink fountain, ink reservoir, or ink tank

Informational Note: For additional guidance, see Chapter 6 of NFPA 33-2011, *Standard for Spray Application Using Flammable or Combustible Materials*, and Chapter 6 of NFPA 34-2011, *Standard for Dipping and Coating Processes Using Flammable or Combustible Liquids*.

(C) Class I, Division 1; Class I, Zone 1; or Class II, Division 1; or Zone 21 Locations. The following spaces shall be considered Class I, Division 1, or Class I, Zone 1, or Class II, Division 1, or Zone 21 locations, as applicable:

(1) The interior of spray booths and rooms except as specifically provided in 516.3(D)(7).

(2) The interior of exhaust ducts.

These are ducts leading to exhaust fans that exhaust materials used in the spraying processes.

(3) Any area in the direct path of spray operations.

(4) For open dipping and coating operations, all space within a 1.5-m (5-ft) radial distance from the vapor sources extending from these surfaces to the floor. The vapor source shall be the liquid exposed in the process and the drainboard, and any dipped or coated object from which it is possible to measure vapor concentrations exceeding 25 percent of the lower flammable limit at a distance of 300 mm (1 ft), in any direction, from the object as in Figure 516.3(D)(1).

(5) Sumps, pits, or belowgrade channels within 7.5 m (25 ft) horizontally of a vapor source. If the sump, pit, or channel extends beyond 7.5 m (25 ft) from the vapor source, it shall be provided with a vapor stop or it shall be classified as Class I, Division 1 for its entire length.

The Code states that all pits having an opening within a Class I, Division 1 or 2 location are Class I, Division 1. If the pit is more than 25 feet horizontally from the vapor source, the entire pit is Division 1.

(6) All space in all directions outside of but within 900 mm (3 ft) of open containers, supply containers, spray gun cleaners, and solvent distillation units containing flammable liquids.

Interiors of Enclosed Coating or Dipping Process. This statement is extracted from NFPA 34, *Standard for Dipping and Coating Processes Using Flammable and Combustible Liquids*. These Division 1 locations include any enclosed coating or dipping operations.

(7) For limited finishing workstations, the area inside the curtains or partitions. See Figure 516.3(D)(5).

INTERPRETATION OF ARTICLE 516: SPRAY APPLICATION, DIPPING, AND COATING PROCESSES

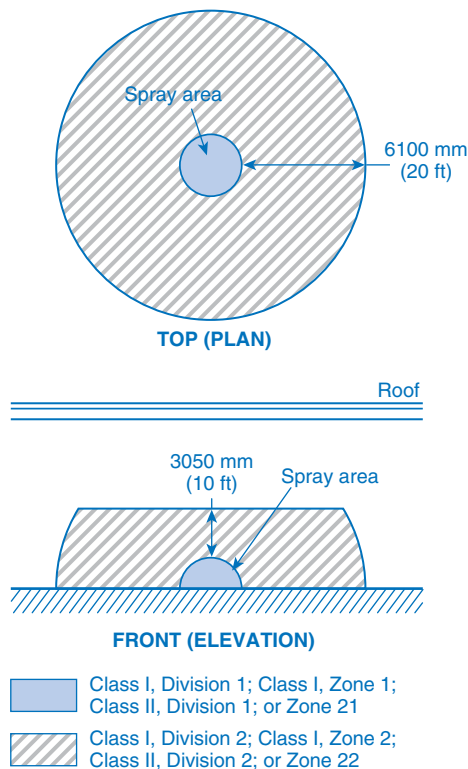

Figure 516.3(D)(1) Electrical Area Classification for Unenclosed Spray Areas. [33:Figure 6.5.1]

(D) Class I, Division 2; Class I, Zone 2; Class II, Division 2; or Zone 22 Locations. The following spaces shall be considered Class I, Division 2; Class I, Zone 2; Class II, Division 2; or Zone 22, as applicable.

(1) Unenclosed Spray Processes. For unenclosed spraying, all space outside of but within 6 m (20 ft) horizontally and 3 m (10 ft) vertically of the Class I, Division 1 or Class I, Zone 1 location as defined in 516.3(A) and not separated from it by partitions. See Figure 516.3(D)(1). [33:6.5.1]

(2) Closed-Top, Open-Face, and Open-Front Spray Booths and Spray Rooms. If spray application operations are conducted within a closed-top, open-face, or open-front booth or room, as shown in Figure 516.3(D)(2), any electrical wiring or utilization equipment located outside of the booth or room but within 915 mm (3 ft) of any opening shall be suitable for Class I, Division 2; Class I, Zone 2; Class II, Division 2; or Zone 22 locations, whichever is applicable. The Class I, Division 2; Class I, Zone 2; Class II, Division 2; or Zone 22 locations shown in Figure 516.3(D)(2) shall extend from the edges of the open face or open front of the booth or room in accordance with the following:

Informational Note: For both interlocked and noninterlocked exhaust ventilation systems, the Division 2, Zone 2 or Zone 22 location extends 915 mm (3 ft) horizontally and 915 mm (3 ft) vertically from the open face or open front of the booth or room, as shown in Figure 516.3(D)(2).

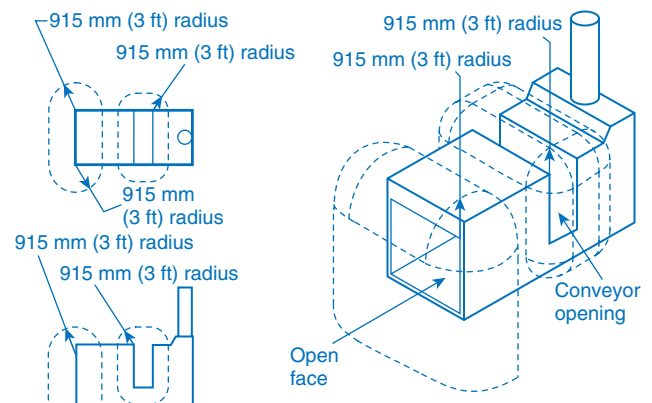

Figure 516.3(D)(2) Class I, Division 2; Class I, Zone 2; Class II, Division 2; or Zone 22 Locations Adjacent to a Closed Top, Open Face, or Open Front Spray Booth or Room.

(3) Open-Top Spray Booths. For spraying operations conducted within an open top spray booth, the space 915 mm (3 ft) vertically above the booth and within 915 mm (3 ft) of other booth openings shall be considered Class I, Division 2; Class I, Zone 2; Class II, Division 2; or Zone 22. [33:6.5.3]

(4) Enclosed Spray Booths and Spray Rooms. For spraying operations confined to an enclosed spray booth or room, electrical area classification shall be as follows: [33:6.5.4]

(1) The area within 915 mm (3 ft) of any opening shall be classified as Class I, Division 2; Class I, Zone 2; Class II, Division 2; or Zone 22 locations, whichever is applicable, as shown in Figure 516.3(D)(4)(1).

(2) Where exhaust air is recirculated, both of the following shall apply:

a. The interior of any recirculation path from the secondary particulate filters up to and including the air supply plenum shall be classified as Class I, Division 2; Class I, Zone 2; Class II, Division 2; or Zone 22 locations, whichever is applicable.

b. The interior of fresh air supply ducts shall be unclassified.

(3) Where exhaust air is not recirculated, the interior of fresh air supply ducts and fresh air supply plenums shall be unclassified.

(5) Limited Finishing Workstations. For limited finishing workstations, the area inside the 915-mm (3-ft) space horizontally and vertically beyond the volume enclosed by the outside surface of the curtains or partitions shall be classified as Class I, Division 2; Class I, Zone 2; Class II, Division 2; or Zone 22, as shown in Figure 516.3(D)(5).

(6) Areas Adjacent to Open Dipping and Coating Processes. Electrical wiring and electrical utilization equipment located adjacent to open processes shall meet the requirements of 516(D)(6)(1) through (4) and Figure 516.3(D)(6)(a), Figure 516.3(D)(6)(b), Figure 516.3(D)(6)(c), Figure 516.3(D)(6)(d), or Figure 516.3(D)(6)(e), whichever is applicable. [34:6.4]

(1) Electrical wiring and electrical utilization equipment located in any sump, pit, or below grade channel that is within 7620 mm (25

INTERPRETATION OF ARTICLE 516: SPRAY APPLICATION, DIPPING, AND COATING PROCESSES

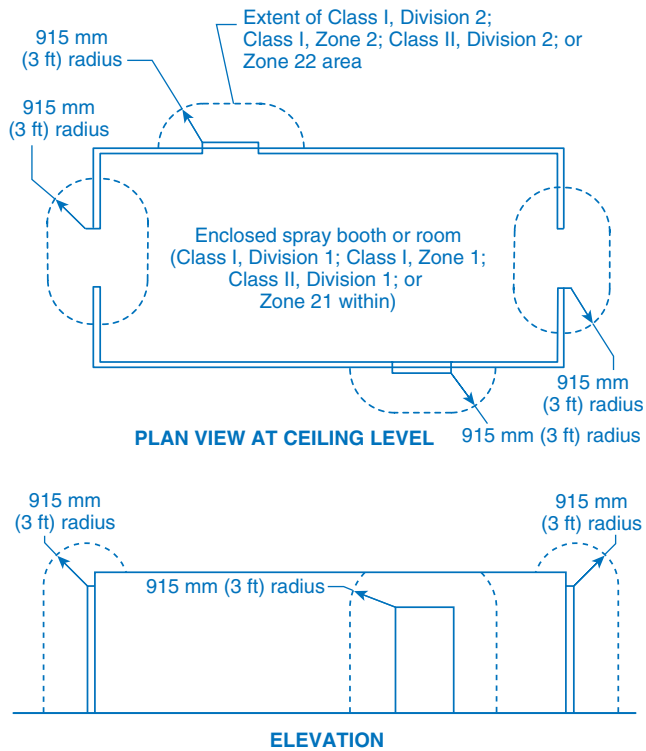

Figure 516.3(D)(4)(1) Class I, Division 2; Class I, Zone 2; Class II, Division 2; or Zone 22 Locations Adjacent to an Enclosed Spray Booth or Spray Room. [33:Figure 6.5.4]

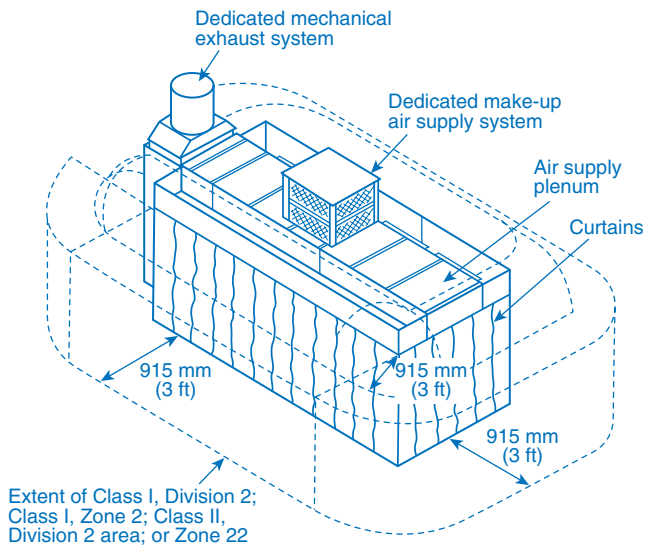

Figure 516.3(D)(5) Class I, Division 2; Class I, Zone 2; Class II, Division 2; or Zone 22 Locations Adjacent to a Limited Finishing Workstation. [33:Figure 14.3.5.1]

ft) horizontally of a vapor source, as defined by this standard, shall be suitable for Class I, Division 1 or Class I, Zone 1 locations. If the sump, pit, or channel extends beyond 7620 mm (25 ft) of the vapor source, it shall be provided with a vapor stop, or it shall be classified as Class I, Division 1 or Class I, Zone 1 for its entire length. [34:6.4.1]

(2) Electrical wiring and electrical utilization equipment located within 1525 mm (5 ft) of a vapor source shall be suitable for Class I, Division 1 or Class I, Zone 1 locations. The space inside a dip tank, ink fountain, ink reservoir, or ink tank shall be classified as Class I, Division 1 or Class I, Zone 0, whichever is applicable. [34:6.4.2]

(3) Electrical wiring and electrical utilization equipment located within 915 mm (3 ft) of the Class I, Division 1 or Class I, Zone 1 location described in 516.3(D)(6)(2) shall be suitable for Class I, Division 2 or Class I, Zone 2 locations, whichever is applicable. [34:6.4.3]

(4) The space 915 mm (3 ft) above the floor and extending 6100 mm (20 ft) horizontally in all directions from the Class I, Division 1 or Class I, Zone 1 location described in 6.4.3 shall be classified as Class I, Division 2 or Class I, Zone 2, and electrical wiring and electrical utilization equipment located within this space shall be suitable for Class I, Division 2 or Class I, Zone 2 locations, whichever is applicable. [34:6.4.4]

Exception: This space shall be permitted to be unclassified for purposes of electrical installations if the surface area of the vapor source does not exceed 0.5 m² (5 ft²), the contents of the dip tank, ink fountain, ink reservoir, or ink tank do not exceed 19 L (5 gal), and the vapor concentration during operating and shutdown periods does not exceed 25 percent of the lower flammable limit.

(7) **Enclosed Coating and Dipping Operations.** Areas adjacent to enclosed dipping and coating processes shall be classified in accordance with 516.3(D)(7) and Figure 516.3(D)(7). The space adjacent to an enclosed dipping or coating process or apparatus shall be considered unclassified. [34:6.5.3]

Exception: The space within 915 mm (3 ft) in all directions from any opening in the enclosures shall be classified as Class I, Division 2 or Class I, Zone 2, as applicable. [34:6.5.2]

The interior of any enclosed dipping or coating process or apparatus shall be a Class I, Division 1 or Class I, Zone 1 location, and electrical wiring and electrical utilization equipment located within this space shall be suitable for Class I, Division 1 or Class I, Zone 1 locations, whichever is applicable. The area inside the dip tank shall be classified as Class I, Division 1 or Class I, Zone 0, whichever is applicable. [34:6.5.1]

(8) **Open Containers.** All space in all directions within 600 mm (2 ft) of the Division 1 or Zone 1 area surrounding open containers, supply containers, spray gun cleaners, and solvent distillation units containing flammable liquids, as well as the area extending 1.5 m (5 ft) beyond the Division 1 or Zone 1 area up to a height of 460 mm (18 in.) above the floor or grade level. [33:6.5.5]

(E) **Adjacent Locations.** Adjacent locations that are cut off from the defined Class I or Class II locations by tight partitions without communicating openings, and within which flammable vapors or combustible powders are not likely to be released, shall be unclassified.

(F) **Unclassified Locations.** Locations using drying, curing, or fusion apparatus and provided with positive mechanical ventilation adequate to prevent accumulation of flammable concentrations of vapors, and provided with effective interlocks to de-energize all electrical

INTERPRETATION OF ARTICLE 516: SPRAY APPLICATION, DIPPING, AND COATING PROCESSES

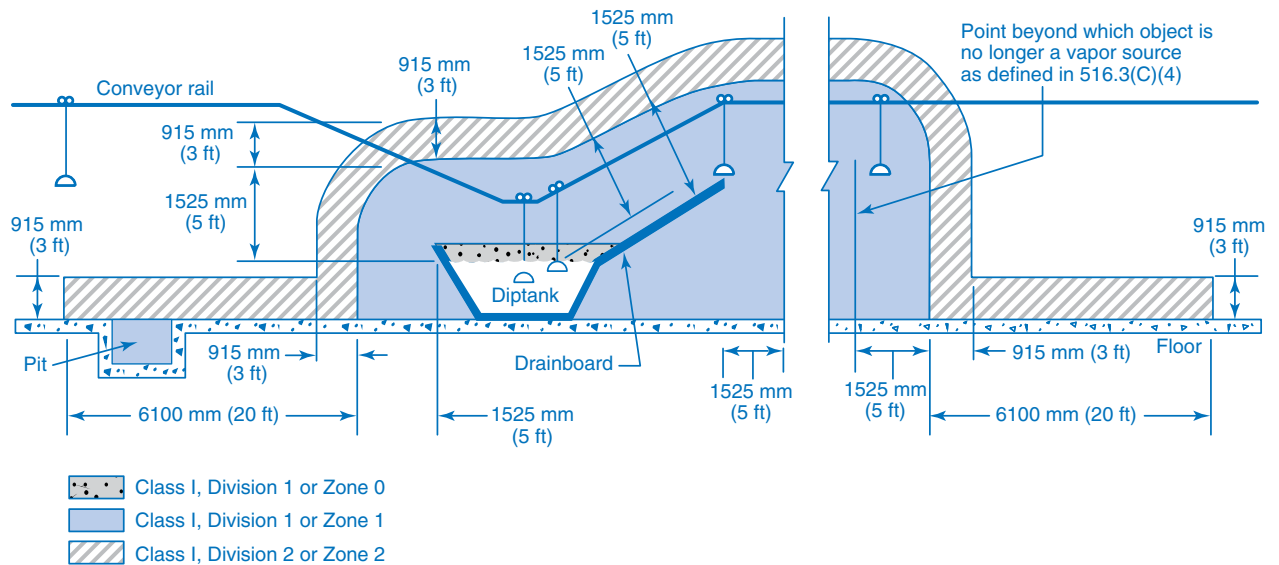
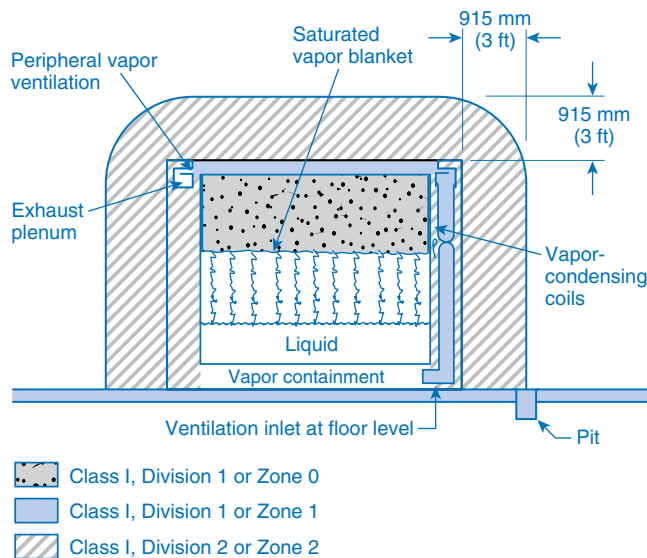

Figure 516.3(D)(6)(a) Electrical Area Classification for Open Dipping and Coating Processes Without Vapor Containment or Ventilation. [34:Figure 6.4(a)]



Definitions

Freeboard: The distance from the maximum solvent or coating material level to the top of the tank

Freeboard ratio: The freeboard height divided by the smaller of the interior length or interior width of the tank

Figure 516.3(D)(6)(b) Electrical Area Classification for Open Dipping and Coating Processes with Peripheral Vapor Containment and Ventilation — Vapors Confined to Process Equipment. [34:Figure 6.4(b)]

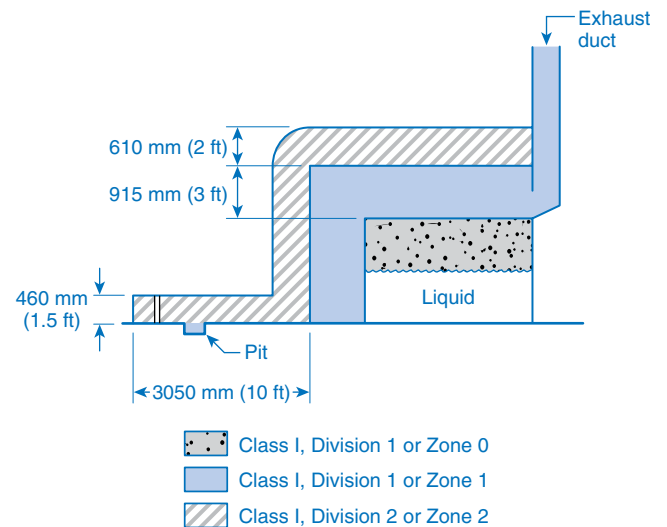

Figure 516.3(D)(6)(c) Electrical Area Classification for Open Dipping and Coating Processes with Partial Peripheral Vapor Containment and Ventilation — Vapors NOT Confined to Process Equipment. [34:Figure 6.4(c)]

INTERPRETATION OF ARTICLE 516: SPRAY APPLICATION, DIPPING, AND COATING PROCESSES

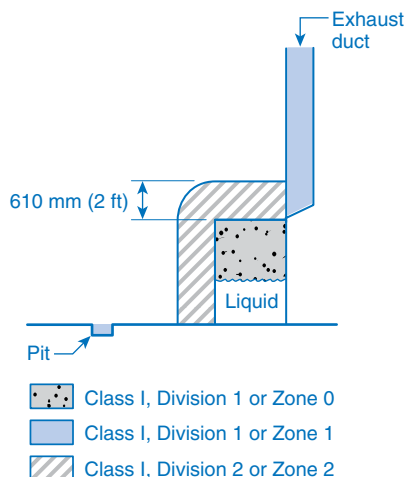

Figure 516.3(D)(6)(d) Electrical Area Classification for Open Dipping and Coating Processes with Partial Peripheral Vapor Containment and Ventilation — Vapors Confined to Process Equipment. [34:Figure 6.4(d)]

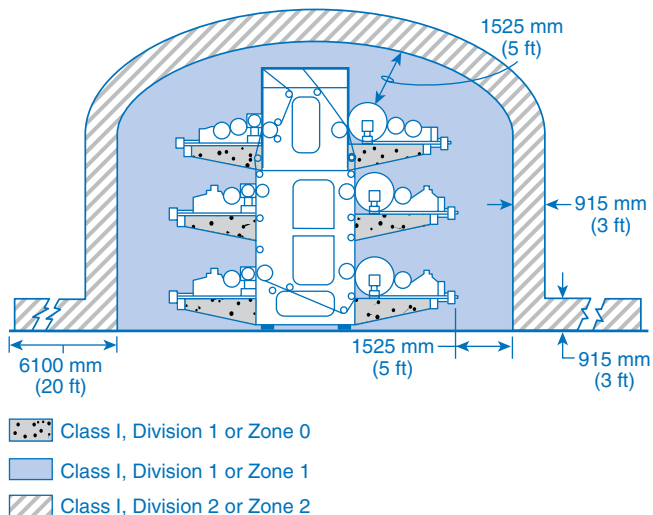

Figure 516.3(D)(6)(e) Electrical Area Classification for a Typical Printing Process. [34:Figure 6.4(e)]

equipment (other than equipment identified for Class I locations) in case the ventilating equipment is inoperative, shall be permitted to be unclassified where the authority having jurisdiction so judges.

Informational Note: For further information regarding safeguards, see NFPA 86-2011, *Standard for Ovens and Furnaces*.

When spraying adjacent to enclosed coating and dipping operations, where the operation is enclosed, the location is nonhazardous. The Exception describes as Class I, Division 2 the space “within 3 feet in all directions from any opening in the enclosure.”

516.4 Wiring and Equipment in Class I Locations.

(A) Wiring and Equipment — Vapors. All electrical wiring and equipment within the Class I location (containing vapor only — not residues) defined in 516.3 shall comply with the applicable provisions of Article 501 or Article 505, as applicable.

(B) Wiring and Equipment — Vapors and Residues. Unless specifically listed for locations containing deposits of dangerous quantities of flammable or combustible vapors, mists, residues, dusts, or deposits (as applicable), there shall be no electrical equipment in any spray area as herein defined whereon deposits of combustible residue may readily accumulate. All electrical wiring shall be comply with 516.4(A).

(C) Illumination.

(1) Luminaires, like that shown in Figure 516.4(C)(1), that are attached to the walls or ceiling of a spray area but that are outside any classified area and are separated from the spray area by glass panels shall be suitable for use in unclassified locations. Such fixtures shall be serviced from outside the spray area. [33:6.6.1]

(2) Luminaires, like that shown in Figure 516.4(C)(1), that are attached to the walls or ceiling of a spray area; that are separated from the spray area by glass panels and that are located within a Class I,

Division 2; a Class I, Zone 2; a Class II, Division 2; or a Zone 22 location shall be suitable for such location. Such fixtures shall be serviced from outside the spray area. [33:6.6.2]

(3) Luminaires, like that shown in Figure 516.4(C)(3), that are an integral part of the walls or ceiling of a spray area shall be permitted to be separated from the spray area by glass panels that are an integral part of the fixture. Such fixtures shall be listed for use in Class I, Division 2; Class I, Zone 2; Class II, Division 2; or

Zone 22 locations, whichever is applicable, and also shall be listed for accumulations of deposits of combustible residues. Such fixtures shall be permitted to be serviced from inside the spray area. [33:6.6.3]

(4) Glass panels used to separate luminaires from the spray area or that are an integral part of the luminaire shall meet the following requirements. a. Panels for light fixtures or for observation shall be of heat-treated glass, laminated glass, wired glass, or hammered-wired glass and shall be sealed to confine vapors, mists, residues, dusts, and deposits to the spray area. [33:5.5.1]

Exception: Listed spray booth assemblies that have vision panels constructed of other materials shall be permitted.

b. Panels for light fixtures shall be separated from the fixture to prevent the surface temperature of the panel from exceeding 93°C (200°F). [33:5.5.2]

c. The panel frame and method of attachment shall be designed to not fail under fire exposure before the vision panel fails. [33:5.5.3]

(D) Portable Equipment. Portable electric luminaires or other utilization equipment shall not be used in a spray area during spray operations.

Exception No. 1: Where portable electric luminaires are required for operations in spaces not readily illuminated by fixed lighting within the spraying area, they shall be of the type identified for Class I, Division 1 or

INTERPRETATION OF ARTICLE 516: SPRAY APPLICATION, DIPPING, AND COATING PROCESSES

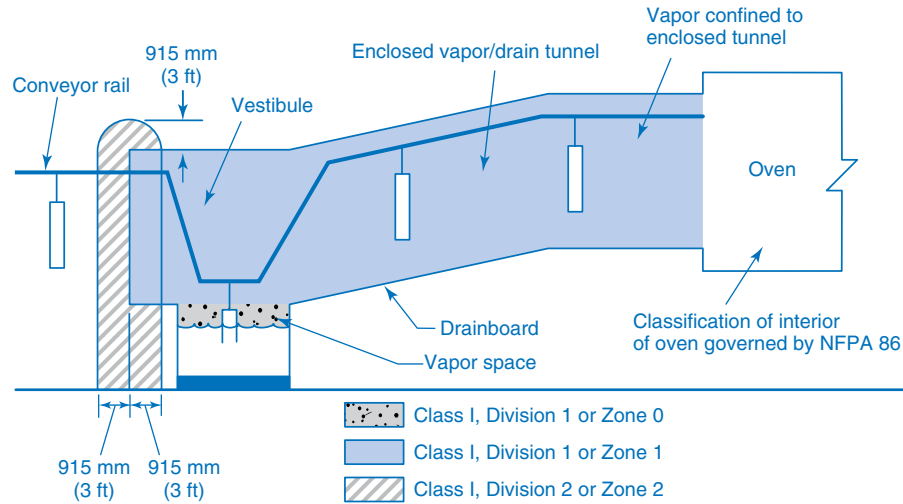

Figure 516.3(D)(7) Electrical Area Classification Around an Enclosed Dipping or Coating Process. [34:Figure 6.5]

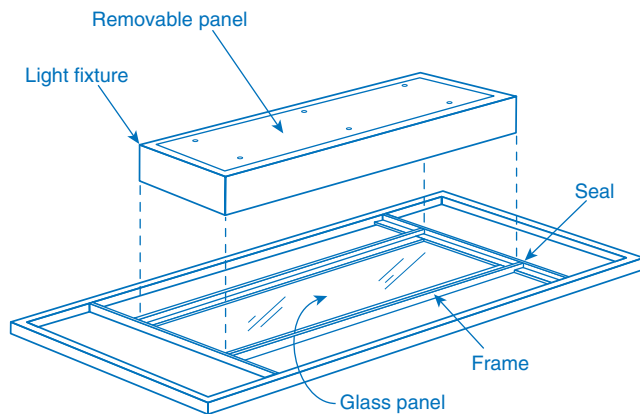

Figure 516.4(C)(1) Example of a Luminaire that is Mounted Outside of the Spray Area and is Serviced from Outside the Spray Area. [33:Figure 6.6.1]

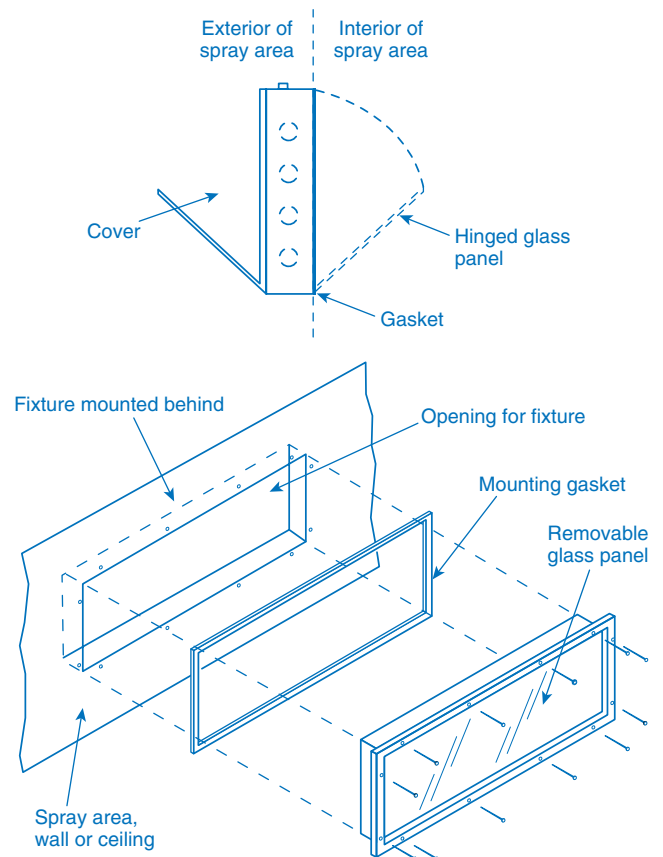

Figure 516.4(C)(3) Example of a Luminaire that is an Integral Part of the Spray Area and is Serviced from Inside the Spray Area. [33:Figure 6.6.3]

Class 1, Zone 1 locations where readily ignitable residues may be present. [33:6.9 Exception]

Exception No. 2: Where portable electric drying apparatus is used in spray booths and the following requirements are met:

(a) The apparatus and its electrical connections are not located within the spray enclosure during spray operations.

(b) Electrical equipment within 450 mm (18 in.) of the floor is identified for Class I, Division 2 or Class I, Zone 2 locations.

(c) All metallic parts of the drying apparatus are electrically bonded and grounded.

(d) Interlocks are provided to prevent the operation of spray equipment while drying apparatus is within the spray enclosure, to allow for a

INTERPRETATION OF ARTICLE 516: SPRAY APPLICATION, DIPPING, AND COATING PROCESSES

3-minute purge of the enclosure before energizing the drying apparatus and to shut off drying apparatus on failure of ventilation system.

(E) Electrostatic Equipment. Electrostatic spraying or detearing equipment shall be installed and used only as provided in 516.10.

Informational Note: For further information, see NFPA 33- 2011, *Standard for Spray Application Using Flammable or Combustible Materials*.

(F) Static Electric Discharges.

(1) All persons and all electrically conductive objects, including any metal parts of the process equipment or apparatus, containers of material, exhaust ducts, and piping systems that convey flammable or combustible liquids, shall be electrically grounded. [34:6.8.1]

(2) Provision shall be made to dissipate static electric charges from all nonconductive substrates in printing processes.

516.7 Wiring and Equipment Not Within Classified Locations.

(A) Wiring. All fixed wiring above the Class I and II locations shall be in metal raceways, Type PVC conduit, Type RTRC conduit, or electrical nonmetallic tubing; where cables are used, they shall be Type MI, Type TC, or Type MC cable. Cellular metal floor raceways shall only be permitted to supply ceiling outlets or as extensions to the area below the floor of a Class I or II location. Where cellular metal raceways are used, they shall not have connections leading into or passing through the Class I or II location unless suitable seals are provided.

This section permits Type PVC conduit and Type RTRC conduit. This better defines the types of rigid nonmetallic conduit that is suitable for the application.

(B) Equipment. Equipment that may produce arcs, sparks, or particles of hot metal, such as lamps and lampholders for fixed lighting, cutouts, switches, receptacles, motors, or other equipment having make-and-break or sliding contacts, where installed above a Classified location or above a location where freshly finished goods are handled, shall be of the totally enclosed type or be constructed so as to prevent the escape of sparks or hot metal particles.

Subsection 516.10(A) was revised by a tentative interim amendment (TIA). See page 1.

Reference to page 1 in the TIA note is to page 1 of NFPA 70.

516.10 Special Equipment.

(A) Fixed Electrostatic Equipment. This section shall apply to any equipment using electrostatically charged elements for the atomization, charging, and/or precipitation of hazardous materials for coatings on articles or for other similar purposes in which the charging or atomizing device is attached to a mechanical support or manipulator. This shall include robotic devices. This section shall not apply to devices that are held or manipulated by hand. Where robot or programming procedures involve manual manipulation of the robot arm while spraying with the high voltage on, the provisions of 516.10(B) shall apply. The installation of electrostatic spraying equipment shall comply with 516.10(A)(1) through (A)(10). Spray equipment shall be listed except as otherwise permitted. All automatic electrostatic equipment systems shall comply with 516.4(A)(1) through (A)(9). [33:1.5]

Informational Note: For more information on listing and approval of electrostatic

spray equipment, see NFPA 33-2011, *Standard for Spray Application Using Flammable or Combustible Materials*, Section 11.5. NFPA 33 permits certain electrostatic spray equipment to be approved for use when additional mitigation equipment is employed.

(1) Power and Control Equipment. Transformers, high-voltage supplies, control apparatus, and all other electrical portions of the equipment shall be installed outside of the Class I location as defined in 516.3 or be of a type identified for the location.

Exception: High-voltage grids, electrodes, electrostatic atomizing heads, and their connections shall be permitted within the Class I location.

(2) Electrostatic Equipment. Electrodes and electrostatic atomizing heads shall be adequately supported in permanent locations and shall be effectively insulated from ground. Electrodes and electrostatic atomizing heads that are permanently attached to their bases, supports, reciprocators, or robots shall be deemed to comply with this section.

(3) High-Voltage Leads. High-voltage leads shall be properly insulated and protected from mechanical damage or exposure to destructive chemicals. Any exposed element at high voltage shall be effectively and permanently supported on suitable insulators and shall be effectively guarded against accidental contact or grounding.

(4) Support of Goods. Goods being coated using this process shall be supported on conveyors or hangers. The conveyors or hangers shall be arranged (1) to ensure that the parts being coated are electrically connected to ground with a resistance of 1 megohm or less and (2) to prevent parts from swinging.

(5) Automatic Controls. Electrostatic apparatus shall be equipped with automatic means that will rapidly deenergize the high-voltage elements under any of the following conditions:

(1) Stoppage of ventilating fans or failure of ventilating equipment from any cause

(2) Stoppage of the conveyor carrying goods through the high-voltage field unless stoppage is required by the spray process

(3) Occurrence of excessive current leakage at any point in the high-voltage system

(4) De-energizing the primary voltage input to the power supply

(6) Grounding. All electrically conductive objects in the spray area, except those objects required by the process to be at high voltage, shall be adequately grounded. This requirement shall apply to paint containers, wash cans, guards, hose connectors, brackets, and any other electrically conductive objects or devices in the area.

Informational Note: For more information on grounding and bonding for static electricity purposes, see NFPA 33-2011, *Standard for Spray Application Using Flammable or Combustible Materials*; NFPA 34-2011, *Standard for Dipping, Coating, and Printing Processes Using Flammable or Combustible Liquids*; and NFPA 77-2014, *Recommended*

Practice on Static Electricity.

(7) Isolation. Safeguards such as adequate booths, fencing, railings, interlocks, or other means shall be placed about the equipment or incorporated therein so that they, either by their location, character, or both, ensure that a safe separation of the process is maintained.

(8) Signs. Signs shall be conspicuously posted to convey the following:

INTERPRETATION OF ARTICLE 516: SPRAY APPLICATION, DIPPING, AND COATING PROCESSES

(1) Designate the process zone as dangerous with regard to fire and accident

(2) Identify the grounding requirements for all electrically conductive objects in the spray area

(3) Restrict access to qualified personnel only

(9) **Insulators.** All insulators shall be kept clean and dry.

(10) **Other Than Nonincendive Equipment.** Spray equipment that cannot be classified as nonincendive shall comply with (A)(10)(a) and (A)(10)(b).

(a) Conveyors, hangers, and application equipment shall be arranged so that a minimum separation of at least twice the sparking distance is maintained between the workpiece or material being sprayed and electrodes, electrostatic atomizing heads, or charged conductors. Warnings defining this safe distance shall be posted. [33:11.4.1]

(b) The equipment shall provide an automatic means of rapidly de-energizing the high-voltage elements in the event the distance between the goods being painted and the electrodes or electrostatic atomizing heads falls below that specified in (a). [33:11.3.8]

(B) **Electrostatic Hand-Spraying Equipment.** This section shall apply to any equipment using electrostatically charged elements for the atomization, charging, or precipitation of flammable and combustible materials for coatings on articles, or for other similar purposes in which the charging or atomizing device is hand-held and manipulated during the spraying operation. Electrostatic hand-spraying equipment and devices used in connection with paint-spraying operations shall be of listed types and shall comply with 516.10(B)(1) through (B)(5).

(1) **General.** The high-voltage circuits shall be designed so as not to produce a spark of sufficient intensity to ignite the most readily ignitable of those vapor-air mixtures likely to be encountered, or result in appreciable shock hazard upon coming in contact with a grounded object under all normal operating conditions. The electrostatically charged exposed elements of the handgun shall be capable of being energized only by an actuator that also controls the coating material supply.

(2) **Power Equipment.** Transformers, power packs, control apparatus, and all other electrical portions of the equipment shall be located outside of the Class I location or be identified for the location.

Exception: The handgun itself and its connections to the power supply shall be permitted within the Class I location.

(3) **Handle.** The handle of the spraying gun shall be electrically

connected to ground by a conductive material and be constructed so that the operator in normal operating position is in direct electrical contact with the grounded handle with a resistance of not more than 1 megohm to prevent buildup of a static charge on the operator's body. Signs indicating the necessity for grounding other persons entering the spray area shall be conspicuously posted.

(4) **Electrostatic Equipment.** All electrically conductive objects in the spraying area, except those objects required by the process to be at high voltage, shall be electrically connected to ground with a resistance of not more than 1 megohm. This requirement shall apply to paint containers, wash cans, and any other electrical conductive objects or devices in the area. The equipment shall carry a prominent, permanently installed warning regarding the necessity for this

grounding feature.

Informational Note: For more information on grounding and bonding for static electricity purposes, see NFPA 33-2011, *Standard for Spray Application Using Flammable or Combustible Materials*; NFPA 34-2011, *Standard for Dipping, Coating, and Printing Processes Using Flammable or Combustible Liquids*; and NFPA 77-2014, *Recommended Practice on Static Electricity*.

(5) **Support of Objects.** Objects being painted shall be maintained in electrical contact with the conveyor or other grounded support. Hooks shall be regularly cleaned to ensure adequate grounding of 1 megohm or less. Areas of contact shall be sharp points or knife edges where possible. Points of support of the object shall be concealed from random spray where feasible; and, where the objects being sprayed are supported from a conveyor, the point of attachment to the conveyor shall be located so as to not collect spray material during normal operation. [33: Chapter 12]

(C) **Powder Coating.** This section shall apply to processes in which combustible dry powders are applied. The hazards associated with combustible dusts are present in such a process to a degree, depending on the chemical composition of the material, particle size, shape, and distribution.

(1) **Electrical Equipment and Sources of Ignition.** Electrical equipment and other sources of ignition shall comply with the requirements of Article 502. Portable electric luminaires and other utilization equipment shall not be used within a Class II location during operation of the finishing processes. Where such luminaires or utilization equipment are used during cleaning or repairing operations, they shall be of a type identified for Class II, Division 1 locations, and all exposed metal parts shall be connected to an equipment grounding conductor.

Exception: Where portable electric luminaires are required for operations in spaces not readily illuminated by fixed lighting within the spraying area, they shall be of the type listed for Class II, Division 1 locations where readily ignitable residues may be present.

(2) **Fixed Electrostatic Spraying Equipment.** The provisions of 516.10(A) and 516.10(C)(1) shall apply to fixed electrostatic spraying equipment.

(3) **Electrostatic Hand-Spraying Equipment.** The provisions of 516.10(B) and 516.10(C)(1) shall apply to electrostatic hand-spraying equipment.

(4) **Electrostatic Fluidized Beds.** Electrostatic fluidized beds and associated equipment shall be of identified types. The high-voltage circuits shall be designed such that any discharge produced when the charging electrodes of the bed are approached or contacted by a grounded object shall not be of sufficient intensity to ignite any powder-air mixture likely to be encountered or to result in an appreciable shock hazard.

(a) Transformers, power packs, control apparatus, and all other electrical portions of the equipment shall be located outside the powder-coating area or shall otherwise comply with the requirements of 516.10(C)(1).

Exception: The charging electrodes and their connections to the power supply shall be permitted within the powdercoating area.

(b) All electrically conductive objects within the powder-coating area shall be adequately grounded. The powder-coating equipment shall carry a prominent, permanently installed warning regarding the necessity for grounding these objects.

INTERPRETATION OF ARTICLE 516: SPRAY APPLICATION, DIPPING, AND COATING PROCESSES

Informational Note: For more information on grounding and bonding for static electricity purposes, see NFPA 33-2011, *Standard for Spray Application Using Flammable or Combustible Materials*; NFPA 34-2011, *Standard for Dipping, Coating, and Printing Processes Using Flammable or Combustible Liquids*; and NFPA 77-2014, *Recommended Practice on Static Electricity*.

(c) Objects being coated shall be maintained in electrical contact (less than 1 megohm) with the conveyor or other support in order to ensure proper grounding. Hangers shall be regularly cleaned to ensure effective electrical contact.

Areas of electrical contact shall be sharp points or knife edges where possible.

(d) The electrical equipment and compressed air supplies shall be interlocked with a ventilation system so that the equipment cannot be operated unless the ventilating fans are in operation. [33: Chapter 15]

516.16 Grounding. All metal raceways, the metal armors or metallic sheath on cables, and all non-current-carrying metal parts of fixed or portable electrical equipment, regardless of voltage, shall be grounded and bonded. Grounding and bonding shall comply with 501.30, 502.30, or 505.25, as applicable.

Informational Note: For more information on grounding and bonding for static electricity purposes, see NFPA 33-2011, *Standard for Spray Application Using Flammable or Combustible Materials*; NFPA 34-2011, *Standard for Dipping and Coating Processes Using Flammable or Combustible Liquids*; and NFPA 77-2007, *Recommended Practice on Static Electricity*.

(c) Objects being coated shall be maintained in electrical contact (less than 1 megohm) with the conveyor or other support in order to ensure proper grounding. Hangers shall be regularly cleaned to ensure effective electrical contact. Areas of electrical contact shall be sharp points or knife edges where possible.

(d) The electrical equipment and compressed air supplies shall be interlocked with a ventilation system so that the equipment cannot be operated unless the ventilating fans are in operation. [33: Chapter 15]

516.16 - Grounding. All metal raceways, the metal armors or metallic sheath on cables, and all non-current-carrying metal parts of fixed or portable electrical equipment, regardless of voltage, shall be grounded and bonded. Grounding and bonding shall comply with 501.30, 502.30, or 505.25, as applicable.



APPENDIX A-1: CLASS I FLAMMABLE GASES AND VAPORS

Data is from NFPA 497-2012, *Recommended Practice for the Classification of Flammable Liquids, Gases, or Vapors and of Hazardous (Classified) Locations for Electrical Installations in Chemical Process Areas*.

Chemical	CAS No.	Class I Division Group	Class I Zone Group	Flash Point		Auto Ignition Temperature		Flammable (Explosive) Limits Percent by Volume		Vapor Density (Air = 1)
				°C	°F Reference ⑥	°C	°F Reference ⑥	°C	°F Reference ⑥	
Acetaldehyde	75-07-0	C	IIA	-38	-36	175	347	4.0	60.0	1.5
Acetic Acid	64-19-7	D	IIA	39	102	426	799		19.9	2.1
Acetic Acid-ert-Butyl Ester	540-88-5	D						1.7	9.8	4.0
Acetic Anhydride	108-24-7	D	IIA	49	120	316	601	2.7	10.3	3.5
Acetone	67-64-1	D	IIA	-20	-4	465	869	2.5	12.8	2.0
Acetone Cyanohydrin	75-86-5	D		74	165	688	1270	2.2	12.0	2.9
Acetonitrile	75-05-8	D	IIA	6	43	524	975	3.0	16.0	1.4
Acetylene	74-86-2	A	IIC			305	581	2.5	100	0.9
Acrolein (Inhibited)	107-02-8	B(C)②	IIB			235	455	2.8	31.0	1.9
Acrylic Acid	79-10-7	D	IIB	54	129	438	820	2.4	8.0	2.5
Acrylonitrile	107-13-1	D	IIB	0	32	481	898	3	17	1.8
Adiponitrile	111-69-3	D		93	199	550	1022			1.0
Allyl Alcohol	107-18-6	c	IIB	22	72	378	712	2.5	18.0	2.0
Allyl Chloride	107-05-1	D	IIA	-32	-26	485	905	2.9	11.1	2.6
Allyl Glycidyl Ether	106-92-3	B(C)②				57	135			3.9
Alpha-Methyl Styrene	98-83-9	D				574	1065	0.8	11.0	4.1
n-Amyl Acetate	628-63-7	D	IIA	25	77	360	680	1.1	7.5	4.5
sec-Amyl Acetate	626-38-0	D	IIA	23	73			1.1	7.5	4.5
Ammonia	7664-41-7	D1	IIA			651	1204	15	28	0.6
Aniline	62-53-3	D	IIA	70	158	615	1139	1.2	8.3	3.2
Benzene	71-43-2	d	IIA	-11	12	498	928	1.2	7.8	2.8
Benzyl Chloride	98-87-3	D				585	1085	1.1		4.4
Bromopropyne	106-96-7	D		10	50	324	615	3.0		
n-Butane	106-97-8	D⑤	IIA			288	550	1.9	8.5	2.0
1,3-Butadiene	106-99-0	B(D)②	IIB			420	788	2.0	11.5	1.9
1-Butanol	71-36-3	D	IIA	36	97	343	649	1.4	11.2	2.6
Butyl alcohol (s) (butanol-2)	78-92-2	D		23.8	75	405	761	1.7	9.8	2.6
Butylamine	109-73-9	D	IIA	-12	10	312	594	1.7	9.8	2.5
Butylene	25167-67-3	D	IIA			385	725	1.6	10.0	1.9
n-Butyraldehyde	123-72-8	C	IIA	-12	10	218	424	1.9	12.5	2.5
n-Butyl Acetate	123-86-4	D	IIA	22	72	421	790	1.7	7.6	4.0
sec-Butyl Acetate	105-46-4	D		-8	18			1.7	9.8	4.0
tert-Butyl Acetate	540-88-5	D						1.7	9.8	4.0
n-Butyl Acrylate (Inhibited)	141-32-2	D	IIB	49	120	293	559	1.7	9.9	4.4
n-Butyl Glycidyl Ether	2426-08-6	B(C)②								
n-Butyl Formal	110-62-3	C								
Butyl Mercaptan	109-79-5	C		2	36					3.1
Butyl-2-Propenoate	141-32-2	D		49	120	1.7	35	9.9	4.4	5.5
para tert-Butyl Toluene	98-51-1	D								
n-Butyric Acid	107-92-6	D		72	162	443	829	2.0	10.0	3.0
Carbon Disulfide	75-15-0	③	IIC	-30	-22	90	194	1.3	50.0	2.6
Carbon Monoxide	630-08-0	C	IIB			609	1128	12.5	74	0.97
Chloroacetaldehyde	107-20-0	C		88	190					
Chlorobenzene	108-90-7	D		29	84	593	1099	1.3	9.6	3.9
1-Chloro-1- Nitropropane	2425-66-3	C								
Chloroprene	126-99-8	D		-20	-4			4.0	20.0	3.0
Cresol	1319-77-3	D		81	178	559	1038	1.1		3.7
Crotonaldehyde	4170-30-3	C	IIB	13	55	232	450	2.1	15.5	2.4

① For classification of areas involving ammonia, see ASHRAE 15, *Safety Code for Mechanical Refrigeration*, and ANSI/CGA G2.1, *Safety Requirements for the Storage and Handling of Anhydrous Ammonia*.

② Where all conduit runs into explosionproof equipment are provided with explosionproof seals installed within 450 mm (18 in.) of the enclosure, equipment for the group classification shown in parentheses is permitted.

③ Certain chemicals have characteristics that require safeguards beyond those required for any of the above groups. Carbon disulfide is one of these chemicals because of its low autoignition temperature and the small joint clearance necessary to arrest its flame propagation.

④ Petroleum naphtha is a saturated hydrocarbon mixture whose boiling range is 20°C to 135°C (68°F to 275°F). It is also known as benzene, ligroin, petroleum ether, and naphtha.

⑤ Commercial grades of aliphatic hydrocarbon solvents are mixtures of several isomers of the same chemical formula (or molecular weight). The autoignition temperatures (AIT) of the individual isomers are significantly different. The electrical equipment should be suitable for the AIT of the solvent mixture. (See A.4.4.2 of NFPA 497-2012).

⑥ The Fahrenheit conversions are rounded to the nearest °F.

⑦ Liquid type and flash point vary due to regional blending differences.

⑧ Fuel and process gas mixtures found by test not to present hazards similar to those of hydrogen may be grouped based on the test results.

APPENDIX A-1: CLASS I FLAMMABLE GASES AND VAPORS

Data is from NFPA 497-2012, *Recommended Practice for the Classification of Flammable Liquids, Gases, or Vapors and of Hazardous (Classified) Locations for Electrical Installations in Chemical Process Areas*.

Chemical	CAS No.	Class I Division Group	Class I Zone Group	Flash Point		Auto Ignition Temperature		Flammable (Explosive) Limits Percent by Volume		Vapor Density (Air = 1)
				°C	°F Reference ⑥	°C	°F Reference ⑥	°C	°F Reference ⑥	
Cumene	98-82-8	D	IIA	36	97	424	795	0.9	6.5	4.1
Cyclohexane	110-82-7	D	IIA	-17	1	245	473	1.3	8.0	2.9
Cyclohexanol	108-93-0	D	IIA	68	154	300	572			3.5
Cyclohexanone	108-94-1	D	IIA	44	111	420	788	1.1	9.4	3.4
Cyclohexene	110-83-8	D	IIA	-6	21	244	471	1.2		2.8
Cyclopropane	75-19-4	D	IIA			503	937	2.4	10.4	1.5
p-Cymene	99-87-6	D	IIA	47	117	436	817	0.7	5.6	4.6
Decene	872-05-9	D				235	455			4.8
n-Decaldehyde	112-31-2	C								
n-Decanol	112-30-1	D		82	180	288	550			5.3
Decyl Alcohol	112-30-1	D		82	180	288	550			5.3
Diacetone Alcohol	123-42-2	D		64	147	603	1117	1.8	6.9	4.0
Di-Isobutylene	25167-70-8	D		2	36	391	736	0.8	4.8	3.8
Di-Isobutyl Ketone	108-83-8	D		60	140	396	745	0.8	7.1	4.9
o-Dichlorobenzene	955-50-1	D	IIA	66	151	647	1197	2.2	9.2	5.1
1,4-Dichloro-2,3 Epoxybutane	3583-47-9	D	IIA					1.9	8.5	2.0
1,1-Dichloroethane	1300-21-6	D	IIA			438	820	6.2	16.0	3.4
1,2-Dichloroethylene	156-59-2	D	IIA	97	207	460	860	5.6	12.8	3.4
1,1-Dichloro-1-Nitroethane	594-72-9	C		76	169					5.0
1,3-Dichloropropene	10061-02-6	D		35	95			5.3	14.5	3.8
Dicyclopentadiene	77-73-6	C	IIA	32	90	503	937			
Diethylamine	109-87-9	C	IIA	-28	-18	312	594	1.8	10.1	2.5
Diethylaminoethanol	100-37-8	C	IIA	60	140	320	608			4.0
Diethyl Benzene	25340-17-4	D		57	135	395	743			4.6
Diethyl Ether (Ethyl Ether)	60-29-7	C	IIB	-45	-49	160	320	1.9	36	2.6
Diethylene Glycol Monobutyl Ether	112-34-5	C		78	172	228	442	0.9	24.6	5.6
Diethylene Glycol Monomethyl Ether	111-77-3	C		93	199	241	466			
n-n-Dimethyl Aniline	121-69-7	C		63	145	371	700	1.0		4.2
Dimethyl Formamide	68-12-2	D	IIA	58	136	455	851	2.2	15.2	2.5
Dimethyl Sulfate	77-78-1	D		83	181	188	370			4.4
Dimethylamine	124-40-3	C	IIA			400	752	2.8	14.4	1.6
2,2-Dimethylbutane	75-83-2	D⑤		-48	-54	405	761			
2,3-Dimethylbutane	78-29-8	D⑤				396	745			
3,3-Dimethylheptane	1071-26-7	D⑤				325	617			
2,3-Dimethylhexane	31394-54-4	D⑤				438	820			
2,3-Dimethylpentane	107-83-5	D⑤				335	635			
Di-N-Propylamine	142-84-7	C	IIA	17	63	299	570			
1,4-Dioxane	123-91-1	C	IIB	12	54	180	356	2.0	22.0	3.0
Dipentene	138-86-3	D	IIA	45	113	237	459	0.7	6.1	4.7
Dipropylene Glycol Methyl Ether	34590-94-8	C		85	185			1.1	3.0	5.1
Diisopropylamine	108-18-9	C	IIA	-6	21	316	601	1.1	7.1	3.5
Dodecene	6842-15-5	D		100	212	255	491			
Epichlorohydrin	3132-64-7	C		33	91	411	772	3.8	21.0	3.2
Ethane	74-84-0	D	IIA	-29	-20	472	882	3.0	12.5	1.0
Ethanol	64-17-5	D	IIA	13	55	363	686	3.3	19.0	1.6
Ethylamine	75-04-7	D		-18	0	385	545	3.5	14.0	1.6
Ethylene	74-85-1	C	IIB			490	914	2.7	36.0	1.0
Ethylenediamine	107-15-3	D		33	91	385	725	2.5	12.0	2.1

① For classification of areas involving ammonia, see ASHRAE 15, *Safety Code for Mechanical Refrigeration*, and ANSI/CGA G2.1, *Safety Requirements for the Storage and Handling of Anhydrous Ammonia*.

② Where all conduit runs into explosionproof equipment are provided with explosionproof seals installed within 450 mm (18 in.) of the enclosure, equipment for the group classification shown in parentheses is permitted.

③ Certain chemicals have characteristics that require safeguards beyond those required for any of the above groups. Carbon disulfide is one of these chemicals because of its low autoignition temperature and the small joint clearance necessary to arrest its flame propagation.

④ Petroleum naphtha is a saturated hydrocarbon mixture whose boiling range is 20°C to 135°C (68°F to 275°F). It is also known as benzine, ligroin, petroleum ether, and naphtha.

⑤ Commercial grades of aliphatic hydrocarbon solvents are mixtures of several isomers of the same chemical formula (or molecular weight). The autoignition temperatures (AIT) of the individual isomers are significantly different. The electrical equipment should be suitable for the AIT of the solvent mixture. (See A.4.4.2 of NFPA 497-2012).

⑥ The Fahrenheit conversions are rounded to the nearest °F.

⑦ Liquid type and flash point vary due to regional blending differences.

⑧ Fuel and process gas mixtures found by test not to present hazards similar to those of hydrogen may be grouped based on the test results.

APPENDIX A-1: CLASS I FLAMMABLE GASES AND VAPORS

Data is from NFPA 497-2012, *Recommended Practice for the Classification of Flammable Liquids, Gases, or Vapors and of Hazardous (Classified) Locations for Electrical Installations in Chemical Process Areas*.

Chemical	CAS No.	Class I Division Group	Class I Zone Group	Flash Point		Auto Ignition Temperature		Flammable (Explosive) Limits Percent by Volume		Vapor Density (Air = 1)
				°C	°F Reference ⑥	°C	°F Reference ⑥	°C	°F Reference ⑥	
Ethylenimine	151-56-4	C		-11	12	320	608	3.3	54.8	1.5
Ethylene Chlorohydrin	107-07-3	D		59	138	425	797	4.9	15.9	2.8
Ethylene Dichloride	107-06-2	D		13	55	413	776	6.2	16.0	3.4
Ethylene Glycol Monoethyl Ether Acetate	111-15-9	C	IIA	47	117	379	714	1.7		4.7
Ethylene Glycol Monobutyl Ether Acetate	112-07-2	C				340	644	0.9	8.5	
Ethylene Glycol Monobutyl Ether	111-76-2	C		238	460	1.1	34	12.7	4.1	1.0
Ethylene Glycol Monoethyl Ether	110-80-5	C		235	455	1.7	35	15.6	3.0	5.4
Ethylene Glycol Monomethyl Ether	109-86-4	D		285	545	1.8	35	14.0	2.6	9.2
Ethylene Oxide	75-21-8	B(C)②	IIB	-20	-4	429	804	3	100	1.5
2-Ethylhexaldehyde	123-05-7	C		52	126	191	376	0.8	7.2	4.4
2-Ethylhexanol	104-76-7	D		81	178			0.9	9.7	4.5
2-Ethylhexyl Acrylate	103-09-3	D		88	190	252	486			
Ethyl Acetate	141-78-6	D	IIA	-4	25	427	801	2.0	11.5	3.0
Ethyl Acrylate (Inhibited)	140-88-5	D	IIA	9	48	372	621	1.4	14.0	3.5
Ethyl Alcohol	64-17-5	D	IIA	13	55	363	685	3.3	19.0	1.6
Ethyl Sec-Amyl Ketone	541-85-5	D		59	139					
Ethyl Benzene	100-41-4	D		15	59	432	810	0.8	6.7	3.7
Ethyl Butanol	97-95-0	D		57	135			1.2	7.7	3.5
Ethyl Butyl Ketone	106-35-4	D		46	115					4.0
Ethyl Chloride	75-00-3	D		-50	-58	519	966	3.8	15.4	2.2
Ethyl Formate	109-94-4	D	IIA	-20	-4	455	851	2.8	16.0	2.6
Ethyl Mercaptan	75-08-1	C	IIB	-18	0	300	572	2.8	18.0	2.1
n-Ethyl Morpholine	100-74-3	C		32	90					4.0
2-Ethyl-3-Propyl Acrolein	645-62-5	C		68	154					4.4
Ethyl Silicate	78-10-4	D								7.2
Formaldehyde (Gas)	50-00-0	B	IIB			430	806	7	73	1.0
Formic Acid	64-18-6	D	IIA	50	122	434	813	18.0	57.0	1.6
Fuel Oil 1	8008-20-6	D		38-72 ⑦	100-162 ⑦	210	410	0.7	5.0	
Fuel Oil 2				52-96 ⑦	126-205 ⑦	257	495			
Fuel Oil 6				66-132 ⑦	151-270 ⑦					
Furfural	98-01-1	C		60	140	316	601	2.1	19.3	3.3
Furfuryl Alcohol	98-00-0	C		75	167	490	914	1.8	16.3	3.4
Gasoline	8006-61-9	D		-46	-51	280	536	1.4	7.6	3.0
n-Heptane	142-82-5	D	IIA	-4	25	204	399	1.0	6.7	3.5
n-Heptene	81624-04-6	D⑤		-1	30	204	399			3.4
n-Hexane	110-54-3	D⑤	IIA	-23	-9	225	437	1.1	7.5	3.0
Hexanol	111-27-3	D	IIA	63	146					3.5
2-Hexanone	591-78-6	D		35	95	424	795	1.2	8.0	3.5
Hexene	592-41-6	D		-26	-15	245	473	1.2	6.9	
sec-Hexyl Acetate	108-84-9	D		45	113					5.0
Hydrazine	302-01-2	C		38	100	23	73		98.0	1.1
Hydrogen	1333-74-0	B	IIC			500	932	4	75	0.1
Hydrogen Cyanide	74-90-8	C	IIB	-18	0	538	1000	5.6	40.0	0.9
Hydrogen Selenide	7783-07-5	C								
Hydrogen Sulfide	7783-06-4	C	IIB	260	500	4.0	39	44.0	1.2	
Isoamyl Acetate	123-92-2	D		25	77	360	680	1.0	7.5	4.5

① For classification of areas involving ammonia, see ASHRAE 15, *Safety Code for Mechanical Refrigeration*, and ANSI/CGA G2.1, *Safety Requirements for the Storage and Handling of Anhydrous Ammonia*.

② Where all conduit runs into explosionproof equipment are provided with explosionproof seals installed within 450 mm (18 in.) of the enclosure, equipment for the group classification shown in parentheses is permitted.

③ Certain chemicals have characteristics that require safeguards beyond those required for any of the above groups. Carbon disulfide is one of these chemicals because of its low autoignition temperature and the small joint clearance necessary to arrest its flame propagation.

④ Petroleum naphtha is a saturated hydrocarbon mixture whose boiling range is 20°C to 135°C (68°F to 275°F). It is also known as benzene, ligroin, petroleum ether, and naphtha.

⑤ Commercial grades of aliphatic hydrocarbon solvents are mixtures of several isomers of the same chemical formula (or molecular weight). The autoignition temperatures (AIT) of the individual isomers are significantly different. The electrical equipment should be suitable for the AIT of the solvent mixture. (See A.4.4.2 of NFPA 497-2012).

⑥ The Fahrenheit conversions are rounded to the nearest °F.

⑦ Liquid type and flash point vary due to regional blending differences.

⑧ Fuel and process gas mixtures found by test not to present hazards similar to those of hydrogen may be grouped based on the test results.

APPENDIX A-1: CLASS I FLAMMABLE GASES AND VAPORS

Data is from NFPA 497-2012, *Recommended Practice for the Classification of Flammable Liquids, Gases, or Vapors and of Hazardous (Classified) Locations for Electrical Installations in Chemical Process Areas*.

Chemical	CAS No.	Class I Division Group	Class I Zone Group	Flash Point		Auto Ignition Temperature		Flammable (Explosive) Limits Percent by Volume		Vapor Density (Air = 1)
				°C	°F Reference ⑥	°C	°F Reference ⑥	°C	°F Reference ⑥	
Isoamyl Alcohol	123-51-3	D		43	109	350	662	1.2	9.0	3.0
Isobutane	75-28-5	D⑤	IIA			460	860	1.8	8.4	2.0
Isobutyl Acetate	110-19-0	D		18	64	421	790	2.4	10.5	4.0
Isobutyl Acrylate	106-63-8	D				427	801			4.4
Isobutyl Alcohol	78-83-1	D	IIA	-40	-40	416	781	1.2	10.9	2.5
Isobutyraldehyde	78-84-2	C	IIA	-40	-40	196	385	1.6	10.6	2.5
Isodecaldehyde	112-31-2	C								5.4
Isohexane	107-83-5	D⑤	IIA			264	507			
Isopentane	78-78-4	D⑤				420	788			
Isooctyl Aldehyde	123-05-7	C				197	387			
Isophorone	78-59-1	D		84	183	460	860	0.8	3.8	4.8
Isoprene	78-79-5	D		-54	-65	220	428	1.5	8.9	2.4
Isopropyl Acetate	108-21-4	D				460	860	1.8	8.0	3.5
Isopropyl Ether	108-20-3	D	IIA	-28	-18	443	829	1.4	7.9	3.5
Isopropyl Glycidyl Ether	4016-14-2	C								
Isopropylamine	75-31-0	D		-26	-15	402	756	2.3	10.4	2.0
Kerosene	8008-20-6	D	IIA	72	162	210	410	0.7	5.0	
Liquefied Petroleum Gas	68476-85-7	D				405	761			
Mesityl Oxide	141-97-9	D		31	88	344	651	1.4	7.2	3.4
Methane	74-82-8	D	IIA			600	1112	5	15	0.6
Methanol	67-56-1	D	IIA	12	54	385	725	6.0	36.0	1.1
Methyl Acetate	79-20-9	D	IIA	-10	14	454	849	3.1	16.0	2.6
Methyl Acrylate	96-33-3	D	IIB	-3	27	468	874	2.8	25.0	3.0
Methyl Alcohol	67-56-1	D	IIA			385	725	6.0	36	1.1
Methyl Amyl Alcohol	108-11-2	D	IIA	41	106			1.0	5.5	3.5
Methyl Chloride	74-87-3	D	IIA	-46	-51	632	1170	8.1	17.4	1.7
Methyl Ether	115-10-6	C	IIB	-41	-42	350	662	3.4	27.0	1.6
Methyl Ethyl Ketone	78-93-3	D	IIB	-6	21	404	759	1.4	11.4	2.5
Methyl Formal	534-15-6	C		1	34	238	460			3.1
Methyl Formate	107-31-3	D	IIA	-19	-2	449	840	4.5	23.0	2.1
2-Methylhexane	31394-54-4	D⑤				280	536			
Methyl Isobutyl Ketone	108-10-1	D		13	55	440	824	1.2	8.0	3.5
Methyl Isocyanate	624-83-9	D	IIA	-15	5	534	993	5.3	26.0	2.0
Methyl Mercaptan	74-93-1	C		-18	0			3.9	21.8	1.7
Methyl Methacrylate	80-62-6	D	IIA	10	50	422	792	1.7	8.2	3.6
Methyl N-Amyl Ketone	110-43-0	D		49	120	393	739	1.1	7.9	3.9
Methyl Tertiary Butyl Ether	1634-04-4	D		-80	-112	435	815	1.6	8.4	0.2
2-Methyloctane	3221-61-2					220	428			
2-Methylpropane	75-28-5	D⑤				460	860			
Methyl-1-Propanol	78-83-1	D	IIA	-40	-40	416	781	1.2	10.9	2.5
Methyl-2-Propanol	75-65-0	D		10	50	360	680	2.4	8.0	2.6
2-Methyl-5-Ethyl Pyridine	104-90-5	D		74	166			1.1	6.6	4.2
Methylacetylene	74-99-7	C						1.7		1.4
Methylacetylene- Propadiene	27846-30-6	C	IIB							
Methylal	109-87-5	C		-18	0	237	459	1.6	17.6	2.6
Methylamine	74-89-5	D	IIA			430	806	4.9	20.7	1.0
2-Methylbutane	78-78-4	D⑤		-56	-69	420	788	1.4	8.3	2.6
Methylcyclohexane	208-87-2	D		-4	25	250	482	1.2	6.7	3.4

① For classification of areas involving ammonia, see ASHRAE 15, *Safety Code for Mechanical Refrigeration*, and ANSI/CGA G2.1, *Safety Requirements for the Storage and Handling of Anhydrous Ammonia*.

② Where all conduit runs into explosionproof equipment are provided with explosionproof seals installed within 450 mm (18 in.) of the enclosure, equipment for the group classification shown in parentheses is permitted.

③ Certain chemicals have characteristics that require safeguards beyond those required for any of the above groups. Carbon disulfide is one of these chemicals because of its low autoignition temperature and the small joint clearance necessary to arrest its flame propagation.

④ Petroleum naphtha is a saturated hydrocarbon mixture whose boiling range is 20°C to 135°C (68°F to 275°F). It is also known as benzine, ligroin, petroleum ether, and naphtha.

⑤ Commercial grades of aliphatic hydrocarbon solvents are mixtures of several isomers of the same chemical formula (or molecular weight). The autoignition temperatures (AIT) of the individual isomers are significantly different. The electrical equipment should be suitable for the AIT of the solvent mixture. (See A.4.4.2 of NFPA 497-2012).

⑥ The Fahrenheit conversions are rounded to the nearest °F.

⑦ Liquid type and flash point vary due to regional blending differences.

⑧ Fuel and process gas mixtures found by test not to present hazards similar to those of hydrogen may be grouped based on the test results.

APPENDIX A-1: CLASS I FLAMMABLE GASES AND VAPORS

Data is from NFPA 497-2012, *Recommended Practice for the Classification of Flammable Liquids, Gases, or Vapors and of Hazardous (Classified) Locations for Electrical Installations in Chemical Process Areas*.

Chemical	CAS No.	Class I Division Group	Class I Zone Group	Flash Point		Auto Ignition Temperature		Flammable (Explosive) Limits Percent by Volume		Vapor Density (Air = 1)
				°C	°F Reference ⑥	°C	°F Reference ⑥	°C	°F Reference ⑥	
Methylcyclohexanol	25630-42-3	D		68	154	296	565			3.9
2-Methylcyclohexanone	583-60-8	D								3.9
2-Methylheptane		D⑤				420	788			
3-Methylhexane	589-34-4	D⑤				280	536			
3-Methylpentane	94-14-0	D⑤				278	532			
2-Methylpropane	75-28-5	D⑤				460	860			
2-Methyl-1-Propanol	78-83-1	D		-40	-40	223	433	1.2	10.9	2.5
2-Methyl-2-Propanol	75-65-0	D				478	892	2.4	8.0	2.6
2-Methyloctane	2216-32-2	D⑤				220	428			
3-Methyloctane	2216-33-3	D⑤				220	428			
4-Methyloctane	2216-34-4	D⑤				225	437			
Monoethanolamine	141-43-5	D	IIA	85	185	410	770			2.1
Monoisopropanolamine	78-96-6	D		77	171	374	705			2.6
Monomethyl Aniline	100-61-8	C				482	900			
Monomethyl Hydrazine	60-34-4	C		23	73	194	381	2.5	92.0	1.6
Morpholine	110-91-8	C	IIA	35	95	310	590	1.4	11.2	3.0
Naphtha (Coal Tar)	8030-30-6	D	IIA	42	108	277	531			
Naphtha (Petroleum)	8030-30-6	D④	IIA	42	108	288	550	1.1	5.9	2.5
Neopentane	463-82-1	D⑤		-65	-85	450	842	1.4	8.3	2.6
Nitrobenzene	98-95-3	D	IIA	88	190	482	900	1.8		4.3
Nitroethane	79-24-3	C	IIB	28	82	414	777	3.4		2.6
Nitromethane	75-52-5	C	IIA	35	95	418	784	7.3		2.1
1-Nitropropane	108-03-2	C	IIB	34	93	421	790	2.2		3.1
2-Nitropropane	79-46-9	C ^c		28	82	428	802	2.6	11.0	3.1
n-Nonane	111-84-2	D⑤	IIA	31	88	205	401	0.8	2.9	4.4
Nonene	27214-95-8	D						0.8		
Nonyl Alcohol	143-08-8	D	IIA					0.8	6.1	5.0
n-Octane	111-65-9	D⑤	IIA	13	55	206	403	1.0	6.5	3.9
Octene	25377-83-7	D		8	46	230	446	0.9		3.9
n-Octyl Alcohol	111-87-5	D	IIA							4.5
n-Pentane	109-66-0	D⑤	IIA	-40	-40	243	469	1.5	7.8	2.5
1-Pentanol	71-41-0	D	IIA	33	91	300	572	1.2	10.0	3.0
2-Pentanone	107-87-9	D	IIA	7	45	452	846	1.5	8.2	3.0
1-Pentene	109-67-1	D		-18	0	275	527	1.5	8.7	2.4
2-Pentene	109-68-2	D		-18	0					2.4
2-Pentyl Acetate	626-38-0	D		23	74			1.1	7.5	4.5
Phenylhydrazine	100-63-0	D		89	192					3.7
Process Gas > 30% H2		B ⑧				520	968	4.0	75.0	0.1
Propane	74-98-6	D	IIA			450	842	2.1	9.5	1.6
1-Propanol	71-23-8	D	IIA	15	59	413	775	2.2	13.7	2.1
2-Propanol	67-63-0	D	IIA	12	54	399	750	2.0	12.7	2.1
Propiolactone	57-57-8	D						2.9		2.5
Propionaldehyde	123-38-6	C	IIB	-9	16	207	405	2.6	17.0	2.0
Propionic Acid	79-09-4	D	IIA	54	130	466	871	2.9	12.1	2.5
Propionic Anhydride	123-62-6	D		74	166	285	545	1.3	9.5	4.5
n-Propyl Acetate	109-60-4	D	IIA	14	57	450	842	1.7	8.0	3.5
n-Propyl Ether	111-43-3	C		21	70	215	419	1.3	7.0	3.5
Propyl Nitrate	627-13-4	B		20	68	175	347	2.0	100.0	

① For classification of areas involving ammonia, see ASHRAE 15, *Safety Code for Mechanical Refrigeration*, and ANSI/CGA G2.1, *Safety Requirements for the Storage and Handling of Anhydrous Ammonia*.

② Where all conduit runs into explosionproof equipment are provided with explosionproof seals installed within 450 mm (18 in.) of the enclosure, equipment for the group classification shown in parentheses is permitted.

③ Certain chemicals have characteristics that require safeguards beyond those required for any of the above groups. Carbon disulfide is one of these chemicals because of its low autoignition temperature and the small joint clearance necessary to arrest its flame propagation.

④ Petroleum naphtha is a saturated hydrocarbon mixture whose boiling range is 20°C to 135°C (68°F to 275°F). It is also known as benzene, ligroin, petroleum ether, and naphtha.

⑤ Commercial grades of aliphatic hydrocarbon solvents are mixtures of several isomers of the same chemical formula (or molecular weight). The autoignition temperatures (AIT) of the individual isomers are significantly different. The electrical equipment should be suitable for the AIT of the solvent mixture. (See A.4.4.2 of NFPA 497-2012).

⑥ The Fahrenheit conversions are rounded to the nearest °F.

⑦ Liquid type and flash point vary due to regional blending differences.

⑧ Fuel and process gas mixtures found by test not to present hazards similar to those of hydrogen may be grouped based on the test results.

APPENDIX A-1: CLASS I FLAMMABLE GASES AND VAPORS

Data is from NFPA 497-2012, *Recommended Practice for the Classification of Flammable Liquids, Gases, or Vapors and of Hazardous (Classified) Locations for Electrical Installations in Chemical Process Areas*.

Chemical	CAS No.	Class I Division Group	Class I Zone Group	Flash Point		Auto Ignition Temperature		Flammable (Explosive) Limits Percent by Volume		Vapor Density (Air = 1)
				°C	°F Reference ⑥	°C	°F Reference ⑥	°C	°F Reference ⑥	
Propylene	115-07-1	D	IIA			460	860	2.4	10.3	1.5
Propylene Dichloride	78-87-5	D	IIA	16	61	557	1035	3.4	14.5	3.9
Propylene Oxide	75-56-9	B(C)②	IIB	-37	-35	449	840	2.3	36.0	2.0
Pyridine	110-86-1	D	IIA	20	68	482	900	1.8	12.4	2.7
Styrene	100-42-5	D	IIA	31	88	490	914	0.9	6.8	3.6
Tetrahydrofuran	109-99-9	C	IIB	-14	7	321	610	2.0	11.8	2.5
Tetrahydronaphthalene	119-64-2	D				385	725	0.8	5.0	4.6
Tetramethyl Lead	75-74-1	C		38	100					9.2
Toluene	108-88-3	D	IIA	4	39	480	896	1.1	7.1	3.1
n-Tridecene	2437-56-1	D						0.6		6.4
Triethylamine	121-44-8	C	IIA	-9	16	249	480	1.2	8.0	3.5
Triethylbenzene	25340-18-5	D		83	181				56.0	5.6
2,2,3-Trimethylbutane		D⑤				442	828			
2,2,4-Trimethylbutane		D⑤				407	765			
2,2,3-Trimethylpentane		D⑤				396	745			
2,2,4-Trimethylpentane		D⑤	IIA			415	779			
2,3,3-Trimethylpentane		D⑤				425	797			
Tripopylamine	102-69-2	D	IIA	41	106					4.9
Turpentine	8006-64-2	D		35	95	253	487	0.8		
n-Undecene	28761-27-5	D						0.7		5.5
Unsymmetrical Dimethyl Hydrazine	57-14-7	C	0.85	-15	5	249	480	2.0	95.0	1.9
Valeraldehyde	110-62-3	C		280	536	222	432			3.0
Vinyl Acetate	108-05-4	D	IIA	-6	21	402	756	2.6	13.4	3.0
Vinyl Chloride	75-01-4	D	IIA	-78	-108	472	882	3.6	33.0	2.2
Vinyl Toluene	25013-15-4	D		52	126	494	921	0.8	11.0	4.1
Vinylidene Chloride	75-35-4	D	IIA			570	1058	6.5	15.5	3.4
Xylene	1330-20-7	D	0.2	25	77	464	867	0.9	7.0	3.7
Xylidine	121-69-7	C		63	146	371	700	1.0		4.2

① For classification of areas involving ammonia, see ASHRAE 15, *Safety Code for Mechanical Refrigeration*, and ANSI/CGA G2.1, *Safety Requirements for the Storage and Handling of Anhydrous Ammonia*.

② Where all conduit runs into explosionproof equipment are provided with explosionproof seals installed within 450 mm (18 in.) of the enclosure, equipment for the group classification shown in parentheses is permitted.

③ Certain chemicals have characteristics that require safeguards beyond those required for any of the above groups. Carbon disulfide is one of these chemicals because of its low autoignition temperature and the small joint clearance necessary to arrest its flame propagation.

④ Petroleum naphtha is a saturated hydrocarbon mixture whose boiling range is 20°C to 135°C (68°F to 275°F). It is also known as benzene, ligroin, petroleum ether, and naphtha.

⑤ Commercial grades of aliphatic hydrocarbon solvents are mixtures of several isomers of the same chemical formula (or molecular weight). The autoignition temperatures (AIT) of the individual isomers are significantly different. The electrical equipment should be suitable for the AIT of the solvent mixture. (See A.4.4.2 of NFPA 497-2012).

⑥ The Fahrenheit conversions are rounded to the nearest °F.

⑦ Liquid type and flash point vary due to regional blending differences.

⑧ Fuel and process gas mixtures found by test not to present hazards similar to those of hydrogen may be grouped based on the test results.

APPENDIX A-2: CLASS II COMBUSTIBLE DUSTS

Data is from NFPA 499-2013, *Recommended Practice for the Classification of Combustible Dusts and of Hazardous (Classified) Locations for Electrical Equipment Installations in Chemical Process Areas*.

Notes: (General) NFPA 499-2008 has classified 25 Group E, 10 Group F and 185 Group G combustible dusts. The tables shown below, does not include all dusts that may be encountered in business and industry. Some dusts were not classified because they have explosive characteristics that require safeguards that go beyond those required for combustible dusts classified by NEC®. On the other hand, other dusts were not classified because they do not represent a significant hazard, that is, they are not combustible. However, any combustible dust not included in these tables (such as thorium hydride and uranium) should be investigated by a qualified testing laboratory (see NFPA "Fire Protection Handbook," for additional dusts not classified by NEC®. Even such pesticide combustible dusts as Ferbam, Manganese Vancide and Sevin classified above, which have ignition temperatures below that which would be safe within the operating temperature ranges presented in Section 500.8(C) and Table 500.8(C)(2), may present serious problems. Also, caution is advised with combustible dusts that melt or sublime below the operating temperature of the electrical equipment (see footnotes 3 and 4 above).

(1) Normally, the minimum ignition temperature of a layer of a specific dust is lower than the minimum ignition temperature of a cloud of that dust. Since this is not universally true, the lower of the two minimum ignition temperatures is listed. If no symbol appears in the "Code" column, then the layer ignition temperature is shown. "CL" means the cloud ignition temperature is shown. "NL" means that no layer ignition temperature is available, and the cloud ignition temperature is shown. "M" signifies that the dust layer melts before it ignites; the cloud ignition temperature is shown. "S" signifies that the dust layer sublimates before it ignites; the cloud ignition temperature is shown.

(2) Certain metal dusts might have characteristics that require safeguards beyond those required for atmospheres containing the dusts of aluminum, magnesium, and their commercial alloys. For example, zirconium and thorium dusts can ignite spontaneously in air, especially at elevated temperatures.

(3) Due to the impurities found in coal, its ignition temperatures vary regionally, and ignition temperatures are not available for all regions in which coal is mined.

Chemical	CAS No.	NEC		Layer or Cloud Ignition Temperature		
		Division	Group	Code	°C	°F
						Reference ①
Aluminum, A422 flake	7429-90-5	E			320	608
Aluminum, atomized collector fines		E		CL	550	1022
Aluminum—cobalt alloy (60-40)		E			570	1058
Aluminum—copper alloy (50-50)		E			830	1526
Aluminum—lithium alloy (15% Li)		E			400	752
Aluminum—magnesium alloy (dowmetal)		E		CL	430	806
Aluminum—nickel alloy (58-42)		E			540	1004
Aluminum—silicon alloy (12% Si)		E		NL	670	1238
Boron, commercial amorphous (85% B)	7440-42-8	E			400	752
Calcium silicide		E			540	1004
Chromium (97%) electrolytic, milled	7440-47-3	E			400	752
Ferromanganese, medium carbon	12604-53-4	E			290	554
Ferrosilicon (88% Si, 9% Fe)	8049-17-0	E			800	1472
Ferrotitanium (19% Ti, 74.1% Fe, 0.06% C)		E		CL	380	716
Iron, 98% H2 reduced		E			290	554
Iron, 99% carbonyl	13463-40-6	E			310	590
Manganese	7439-96-5	E			240	464
Magnesium, grade B, milled		E			430	806
Tantalum	7440-25-7	E			300	572
Thorium (contains 1.2% O)	7440-29-1	E		CL	270	518
Tin, 96%, atomized (2% Pb)	7440-31-5	E			430	806
Titanium, 99% Ti	7440-32-6	E		CL	330	626
Titanium hydride (95% Ti, 3.8% H)	7704-98-5	E		CL	480	896
Vanadium, 86.4%	7440-62-2	E			490	914
Zirconium hydride	7704-99-6	E			270	518
Zirconium (contains 0.3% O)	7440-67-7	E		CL	330	626
Asphalt	8052-42-4	F			510	950
Carbon black (more than 8% total entrapped volatiles)		F				
Charcoal (activated)	64365-11-3	F			180	356
Charcoal (more than 8% total entrapped volatiles)		F				
Coal, Kentucky bituminous		F			180	356
Coal, Pittsburgh experimental		F			170	338
Coal, Wyoming		F			180	356
Coke (more than 8% total entrapped volatiles)		F				
Gilsonite	12002-43-6	F			500	932
Lignite, California		F			180	356
Petroleum coke (more than 8% total entrapped volatiles)		F				
Pitch, coal tar	65996-93-2	F		NL	710	1310
Pitch, petroleum	68187-58-6	F		NL	630	1166
Shale, oil	68308-34-9	F				
Acetal, linear		G		NL	440	824
Acetoacet-p-phenetidine	122-82-7	G		NL	560	1040
Acetoacetanilide	102-01-2	G		M	440	824
Acrylamino-t-nitrothiazole		G			450	842
Acrylamide polymer		G			240	464
Acrylonitrile polymer		G			460	860

① The Fahrenheit conversions are rounded to the nearest °F.

APPENDIX A-2: CLASS II COMBUSTIBLE DUSTS

Data is from NFPA 499-2013, *Recommended Practice for the Classification of Combustible Dusts and of Hazardous (Classified) Locations for Electrical Equipment Installations in Chemical Process Areas*.

Chemical	CAS No.	NEC Division Group	Code	Layer or Cloud Ignition Temperature	
				°C	°F Reference ①
Acrylonitrile-vinyl chloride-vinylidenechloride copolymer		G		210	410
Acrylonitrile-vinyl pyridine copolymer		G		240	464
Adipic acid	124-04-9	G	M	550	1022
Alfalfa meal		G		200	392
Alkyl ketone dimer sizing compound		G		160	320
Allyl alcohol derivative (CR-39)		G	NL	500	932
Almond shell		G		200	392
Amino-5-nitrothiazole	121-66-4	G		460	860
Anthranilic acid	118-92-3	G	M	580	1076
Apricot pit		G		230	446
Aryl-nitrosomethylamide		G	NL	490	914
Aspirin [acetol (2)]	50-78-2	G	M	660	1220
Azelaic acid	109-31-9	G	M	610	1130
Azo-bis-butyronitrile	78-67-1	G		350	662
Benzethonium chloride		G	CL	380	716
Benzoic acid	65-85-0	G	M	620	1148
Benzotriazole	95-14-7	G	M	440	824
Beta-naphthalene-axo-dimethylaniline		G		175	347
Bis(2-hydroxy-5-chlorophenyl) methane	97-23-4	G	NL	570	1058
Bisphenol-A	80-05-7	G	M	570	1058
Carboxymethyl cellulose	9000-11-7	G		290	554
Carboxypolymethylene		G	NL	520	968
Cashew oil, phenolic, hard		G		180	356
Cellulose		G		260	500
Cellulose acetate		G		340	644
Cellulose acetate butyrate		G	NL	370	698
Cellulose triacetate		G	NL	430	806
Cherry pit		G		220	428
Chlorinated phenol		G	NL	570	1058
Chlorinated polyether alcohol		G		460	860
Chloroacetoacetanilide	101-92-8	G	M	640	1184
Cinnamon		G		230	446
Citrus peel		G		270	518
Cocoa bean shell		G		370	698
Coconut shell		G		220	428
Cork		G		210	410
Corn		G		250	482
Corn dextrine		G		370	698
Corn cob grit		G		240	464
Cornstarch, commercial		G		330	626
Cornstarch, modified		G		200	392
Cottonseed meal		G		200	392
Coumarone-indene, hard		G	NL	520	968
Crag No. 974	533-74-4	G	CL	310	590
Cube root, South America	83-79-4	G		230	446
Di-alpha-cumyl peroxide, 40-60 on CA	80-43-3	G		180	356
Diallyl phthalate	131-17-9	G	M	480	896
Dicyclopentadiene dioxide		G	NL	420	788
Dieldrin (20%)	60-57-1	G	NL	550	1022
Dihydroacetic acid		G	NL	430	806
Dimethyl isophthalate	1459-93-4	G	M	580	1076
Dimethyl terephthalate	120-61-6	G	M	570	1058
Dinitro-o-toluamide	148-01-6	G	NL	500	932
Dinitrobenzoic acid		G	NL	460	860
Diphenyl	92-52-4	G	M	630	1166
Ditertiary-butyl-paracresol	128-37-0	G	NL	420	788
Dithane m-45	8018-01-7	G		180	356
Epoxy		G	NL	540	1004

① The Fahrenheit conversions are rounded to the nearest °F.

APPENDIX A-2: CLASS II COMBUSTIBLE DUSTS

Data is from NFPA 499-2013, *Recommended Practice for the Classification of Combustible Dusts and of Hazardous (Classified) Locations for Electrical Equipment Installations in Chemical Process Areas*.

Chemical	CAS No.	NEC Division Group	Code	Layer or Cloud Ignition Temperature	
				°C	°F Reference ①
Epoxy-bisphenol A		G	NL	510	950
Ethyl cellulose		G	CL	320	608
Ethyl hydroxyethyl cellulose		G	NL	390	734
Ethylene oxide polymer		G	NL	350	662
Ethylene-maleic anhydride copolymer		G	NL	540	1004
Ferbam™	14484-64-1	G		150	302
Flax shive		G		230	446
Fumaric acid	110-17-8	G	M	520	968
Garlic, dehydrated		G	NL	360	680
Green base harmon dye		G		175	347
Guar seed		G	NL	500	932
Gulasonic acid, diacetone		G	NL	420	788
Gum, arabic		G		260	500
Gum, karaya		G		240	464
Gum, manila		G	CL	360	680
Gum, tragacanth	9000-65-1	G		260	500
Hemp hurd		G		220	428
Hexamethylene tetramine	100-97-0	G	S	410	770
Hydroxyethyl cellulose		G	NL	410	770
Isotoic anhydride		G	NL	700	1292
L-sorbose		G	M	370	698
Lignin, hydrolized, wood-type, fine		G	NL	450	842
Lycopodium		G		190	374
Malt barley		G		250	482
Manganese vancide		G		120	248
Mannitol	69-65-8	G	M	460	860
Methacrylic acid polymer		G		290	554
Methionine (l-methionine)	63-68-3	G		360	680
Methyl cellulose		G		340	644
Methyl methacrylate polymer	9011-14-7	G	NL	440	824
Methyl methacrylate-ethyl acrylate		G	NL	440	824
Methyl methacrylate-styrene-butadiene		G	NL	480	896
Milk, skimmed		G		200	392
N,N-dimethylthio-formamide		G		230	446
Nitropyridone	100703-82-0	G	M	430	806
Nitrosamine		G	NL	270	518
Nylon polymer	63428-84-2	G		430	806
Para-oxy-benzaldehyde	123-08-0	G	CL	380	716
Paraphenylene diamine	106-50-3	G	M	620	1148
Paratertiary butyl benzoic acid	98-73-7	G	M	560	1040
Pea flour		G		260	500
Peach pit shell		G		210	410
Peanut hull		G		210	410
Peat, sphagnum	94114-14-4	G		240	464
Pecan nut shell	8002-03-7	G		210	410
Pectin	5328-37-0	G		200	392
Pentaerythritol	115-77-5	G	M	400	752
Pettrin acrylate monomer	7659-34-9	G	NL	220	428
Petroleum resin	64742-16-1	G		500	932
Phenol formaldehyde	9003-35-4	G	NL	580	1076
Phenol formaldehyde, polyalkylene-p	9003-35-4	G		290	554
Phenol furfural	26338-61-4	G		310	590
Phenylbetanaphthylamine	135-88-6	G	NL	680	1256
Phthalic anhydride	85-44-9	G	M	650	1202
Phthalimide	85-41-6	G	M	630	1166
Polycarbonate		G	NL	710	1310
Polyethylene, high pressure process	9002-88-4	G		380	716
Polyethylene, low pressure process	9002-88-4	G	NL	420	788

① The Fahrenheit conversions are rounded to the nearest °F.

APPENDIX A-2: CLASS II COMBUSTIBLE DUSTS

Data is from NFPA 499-2013, *Recommended Practice for the Classification of Combustible Dusts and of Hazardous (Classified) Locations for Electrical Equipment Installations in Chemical Process Areas*.

Chemical	CAS No.	NEC Division Group	Code	Layer or Cloud Ignition Temperature	
				°C	°F Reference ①
Polyethylene terephthalate	25038-59-9	G	NL	500	932
Polyethylene wax	68441-04-8	G	NL	400	752
Polypropylene (no antioxidant)	9003-07-0	G	NL	420	788
Polystyrene latex	9003-53-6	G		500	932
Polystyrene molding compound	9003-53-6	G	NL	560	1040
Polyurethane foam, fire retardant	9009-54-5	G		390	
Polyurethane foam, no fire retardant	9009-54-5	G		440	824
Polyvinyl acetate	9003-20-7	G	NL	550	
Polyvinyl acetate/alcohol	9002-89-5	G		440	824
Polyvinyl butyral	63148-65-2	G		390	
Polyvinyl chloride-dioctyl phthalate		G	NL	320	
Potato starch, dextrinated	9005-25-8	G	NL	440	824
Pyrethrum	8003-34-7	G		210	410
Rayon (viscose) flock	61788-77-0	G		250	482
Red dye intermediate		G		175	347
Rice		G		220	428
Rice bran		G	NL	490	914
Rice hull		G		220	428
Rosin, DK	8050-09-7	G	NL	390	734
Rubber, crude, hard	9006-04-6	G	NL	350	662
Rubber, synthetic, hard (33% S)	64706-29-2	G	NL	320	608
Safflower meal		G		210	410
Salicylanilide	87-17-2	G	M	610	1130
Sevin	63-25-2	G		140	284
Shellac	9000-59-3	G	NL	400	752
Sodium resinate	61790-51-0	G		220	428
Sorbic acid (copper sorbate or potash)	110-44-1	G		460	860
Soy flour	68513-95-1	G		190	374
Soy protein	9010-10-0	G		260	500
Stearic acid, aluminum salt	637-12-7	G		300	572
Stearic acid, zinc salt	557-05-1	G	M	510	950
Styrene modified polyester-glass fiber	100-42-5	G		360	680
Styrene-acrylonitrile (70-30)	9003-54-7	G	NL	500	932
Styrene-butadiene latex (>75% styrene)	903-55-8	G	NL	440	824
Styrene-maleic anhydride copolymer	9011-13-6	G	CL	470	878
Sucrose	57-50-1	G	CL	350	662
Sugar, powdered	57-50-1	G	CL	370	698
Sulfur	7704-34-9	G		220	428
Terephthalic acid	100-21-0	G	NL	680	1256
Trithiobisdimethylthio-formamide		G		230	446
Tung, kernels, oil-free	8001-20-5	G		240	464
Urea formaldehyde molding compound	9011-05-6	G	NL	460	860
Urea formaldehyde-phenol formaldehyde	25104-55-6	G		240	464
Vinyl chloride-acrylonitrile copolymer	9003-00-3	G		470	878
Vinyl toluene-acrylonitrile butadiene	76404-69-8	G	NL	530	986
Violet 200 dye		G		175	347
Vitamin B1, mononitrate	59-43-8	G	NL	360	680
Vitamin C	50-81-7	G		280	536
Walnut shell, black		G		220	428
Wheat		G		220	428
Wheat flour	130498-22-5	G		360	680
Wheat gluten, gum	100684-25-1	G	NL	520	968
Wheat starch		G	NL	380	716
Wheat straw		G		220	428
Wood flour		G		260	500
Woodbark, ground		G		250	482
Yeast, torula	68602-94-8	G		260	500

① The Fahrenheit conversions are rounded to the nearest °F.

APPENDIX B-1: APPLICABLE PRODUCT STANDARDS

API STANDARDS

International Society of Automation

- ANSI/API RP 14FZ-2013, *Recommended Practice for Design, Installation, and Maintenance of Electrical Systems for Fixed and Floating Offshore Petroleum Facilities for Unclassified and Class I, Zone 0, Zone 1, and Zone 2 Locations*
- ANSI/API RP 14F-2013, *Design, Installation, and Maintenance of Electrical Systems for Fixed and Floating Offshore Petroleum Facilities for Unclassified and Class I, Division 1 and Division 2 Locations*
- ANSI/API RP500-2012, *Recommended Practice for Classification of Locations of Electrical Installations at Petroleum Facilities Classified as Class I, Division 1 and Division 2*
- ANSI/API RP 505-1997, *Recommended Practice for Classification of Locations for Electrical Installations at Petroleum Facilities Classified as Class I, Zone 0, Zone 1, or Zone 2*

ASME STANDARDS

- ANSI/ASME B1.20.1-1983, *Pipe Threads, General Purpose (Inch)*

ASTM STANDARDS

ASTM International, originally American Society of Testing and Materials

- ASTM D3175-2011, *Standard Test Method for Volatile Matter in the Analysis Sample for Coal and Coke*
- ASTM E 11-09, *Standard Specification for Wire Cloth and Sieves for Testing Purposes*
- ASTM E 1226-12a, *Standard Test Methods Method for Explosibility of Dust Clouds*

IEEE STANDARDS

Institute of Electrical and Electronics Engineers, Inc.

- IEEE Std. 1349- 2001, *IEEE Guide for the Application of Electric Motors in Class I, Division 2 Hazardous (Classified) Locations*
- ANSI/IEEE C2-2013, *National Electrical Safety Code, Section 127A, Coal Handling Areas*

ISA STANDARDS

International Society of Automation

- ANSI/ISA-60079-0 (12.00.01)-2009, *Explosive Atmospheres – Part 0: Equipment - General Requirements*
- ANSI/ISA-RP 12.06.01-2003, *Recommended Practice for Wiring Methods for Hazardous (Classified) Locations Instrumentation — Part 1: Intrinsic Safety*
- ANSI/ISA-12.12.01-2012, *Nonincendive Electrical Equipment for Use in Class I and II, Division 2, and Class III, Division 1 and 2 Hazardous (Classified) Locations*
- ANSI/ISA-60079-15-2009, *Explosive Atmospheres – Part 15: Equipment protection by type of protection “n”*
- ANSI/ISA 12.12.03-2011, *Standard for Portable Electronic Products Suitable for Use in Class I and II, Division 2 Hazardous (Classified) Locations*
- ANSI/ISA 60079-29-1-2013, *Explosive Atmospheres – Part 29-1: Gas detectors – Performance requirements of detectors for flammable gases*
- ANSI/ISA 12.27.01-2011, *Requirements for Process Sealing Between Electrical Systems and Flammable or Combustible Process Fluids*

- ANSI/ISA 60079-7 (12.16.01)-2008, *Explosive Atmospheres, Part 7: Equipment protection by increased safety “e”*
- ANSI/ISA 60079-1 (12.22.01)-2009, *Explosive Atmospheres, Part 1: Equipment protection by flameproof enclosures “d”*
- ANSI/ISA 60079-18 (12.23.01)-2009, *Explosive Atmospheres – Part 18: Equipment protection by encapsulation “m”*
- ANSI/ISA 61241-10 (12.10.05)-2004, *Electrical Apparatus for Use in Zone 20, 21, and 22 Hazardous (Classified) Locations – Classification of Zone 20, Zone 21, and Zone 22 Hazardous (Classified) Locations*
- ANSI/ISA 60079-5 (12.00.04)-2009, *Explosive Atmospheres, Part 5: Equipment protection by powder filling “q”*
- ISA 12.10-1988, *Area Classification in Hazardous (Classified) Dust Locations*
- ANSI/ISA-TR(12.24.01)-1998 (IEC 60079-10 Mod), *Recommended Practice for Classification of Locations for Electrical Installations Classified as Class I, Zone 0, Zone 1, or Zone 2*

ISO STANDARDS

International Organization of Standardization

- ISO 965/1-2009, *Metric Screw Threads*
- ISO 965/3-2009, *Metric Screw Threads*
- ISO 6184-1, *Explosion protection systems – Part 1: Determination of explosion indices of combustible dusts in air*

INSTITUTE OF PETROLEUM STANDARDS

- *Model Code of Safe Practice in the Petroleum Industry, Part 15: Area Classification Code for Petroleum Installations, IP 15, The Institute of Petroleum, London*

NFPA STANDARDS

National Fire Protection Association

- NFPA 30-2012 *Flammable and Combustible Liquids Code*
- NFPA 30A-2012, *Code for Motor Fuel Dispensing Facilities and Repair Garages*
- NFPA 32-2011, *Standard for Drycleaning Plants*
- NFPA 33-2011, *Standard for Spray Application Using Flammable or Combustible Materials*
- NFPA 34-2011, *Standard for Dipping and Coating Processes Using Flammable or Combustible Liquids*
- NFPA 35-2011, *Standard for the Manufacture of Organic Coatings*
- NFPA 36-2013, *Standard for Solvent Extraction Plants*
- NFPA 45-2011, *Standard on Fire Protection for Laboratories Using Chemicals*
- NFPA 55-2013, *Compressed Gases and Cryogenic Fluids Code*
- NFPA 58-2014, *Liquefied Petroleum Gas Code*
- NFPA 59-2012, *Utility LP-Gas Plant Code*
- NFPA 77-2014, *Recommended Practice on Static Electricity*
- NFPA 86-2011, *Standard for Ovens and Furnaces*
- NFPA 88A-2011, *Standard for Parking Structures*
- NFPA 91-2010, *Standard for Exhaust Systems for Air Conveying of Vapors, Gases, Mists, and Noncombustible Particulate Solids*
- NFPA 409-2011, *Standard for Aircraft Hangers*
- NFPA 496-2013, *Purged and Pressurized Enclosures for Electrical Equipment*
- NFPA 497-2012, *Recommended Practice for the Classification of Flammable Liquids, Gases, or Vapors and of Hazardous (Classified)*

APPENDIX B-1: APPLICABLE PRODUCT STANDARDS

Locations for Electrical Installations in Chemical Process Areas

- NFPA 499-2013, *Recommended Practice for the Classification of Combustible Dusts and of Hazardous (Classified) Locations for Electrical Installations in Chemical Process Areas*
- NFPA 505-2013, *Fire Safety Standard for Powered Industrial Trucks Including Type Designations, Areas of Use, Conversions, Maintenance, and Operation*
- NFPA 820-2012, *Standard for Fire Protection in Wastewater Treatment and Collection Facilities*

DEFINITION OF UL STANDARD NUMBERS.

The UL Catalog “Standards for Safety” presents three categories of UL Standards: (1) Published Standards; (2) Proposed Standards; and (3) Desk Standards. Published Standards and Proposed Standards are shown alphabetically by product category and numerically by the UL Standard number. Desk Standards have no UL Standard numbers. For these, UL selects appropriate requirements from its Published Standards, applying them in evaluating more than 4,000 generic product categories shown in UL’s ten published Product Directories. These products can be tested and UL Listed even though no Published Standard number exists.

In addition to the general *Standards for Safety* catalog, UL publishes individual catalogs on a specific UL Standard number. These catalogs are entitled “UL—, (Standard number), Standard for Safety.” These catalogs describe in detail the UL requirements, including extensive tests, that the specific product must pass to become “UL Listed.”

Note: In 2006 UL Standards 698, 877, 886, 894, and 1010 were withdrawn and the requirements incorporated into UL1203, Explosion-Proof and Dust Ignitionproof Electrical Equipment for use in Hazardous (Classified) Location.

UL STANDARDS

Underwriters Laboratories Inc.

- ANSI/UL 50-2007, *Enclosures for Electrical Equipment, Non-Environmental Considerations*
- ANSI/UL 50E-2007, *Enclosures for Electrical Equipment, Environmental Considerations*
- ANSI/UL 67-2013, *Panelboards*
- ANSI/UL 98-2012, *Enclosed and Dead-Front Switches*
- ANSI/UL 355-2011, *Cord Reels*
- ANSI/UL 467-2013, *Grounding and Bonding Equipment*
- ANSI/UL 498-2014, *Attachment Plugs and Receptacles*
- ANSI/UL 508-2013, *Industrial Control Equipment*
- ANSI/UL 514A-2013, *Metallic Outlet Boxes*
- ANSI/UL 514B-2012, *Conduit, Tubing, and Cable Fittings*
- ANSI/UL 844-2012, *Luminaires for Use in Hazardous (Classified) Locations*
- ANSI/UL 913-2013, *Intrinsically Safe Apparatus and Associated Apparatus for Use in Class I, II, and III, Division 1, Hazardous (Classified) Locations*
- ANSI/UL 924-2014, *Emergency Lighting and Power Equipment*
- ANSI/UL 1203-2013, *Explosionproof and Dust-Ignitionproof Electrical Equipment for Hazardous (Classified) Locations*
- ANSI/UL 1598-2012, *Luminaires*
- ANSI/UL 1598A-2005, *Supplemental Requirements for Luminaires for Installation on Marine Vessels*
- ANSI/UL 1682-2013, *Plugs, Receptacles, and Cable Connectors of the Pin and Sleeve Type*

- ANSI/UL 1686-2014, *Pin and Sleeve Configurations*
- ANSI/UL 2075-2013, *Gas and Vapor Detectors and Sensors*
- ANSI/UL 2225-2013, *Cables and Cable-Fittings For Use In Hazardous (Classified) Locations*
- ANSI/UL 8750-2014, *Light Emitting Diode (LED) Equipment for Use in Lighting Products*
- ANSI/UL 60079-0-2009, *Electrical Apparatus for Explosive Gas Atmospheres — Part 0: General Requirements*
- ANSI/UL 60079-1-2009, *Electrical Apparatus for Explosive Gas Atmospheres — Part 1: Flameproof Enclosures “d”*
- ANSI/UL 60079-5-2009, *Electrical Apparatus for Explosive Gas Atmospheres — Part 5: Powder Filling “q”*
- ANSI/UL 60079-6-2009, *Electrical Apparatus for Explosive Gas Atmospheres — Part 6: Oil-Immersion “o”*
- ANSI/UL 60079-7-2009, *Electrical Apparatus for Explosive Gas Atmospheres — Part 7: Increased Safety “e”*
- ANSI/UL 60079-11-2011, *Electrical Apparatus for Explosive Gas Atmospheres — Part 11: Intrinsic Safety “i”*
- ANSI/UL 60079-15-2009, *Electrical apparatus for explosive gas atmospheres — Part 15: Type of protection “n”*
- ANSI/UL 60079-18-2009, *Explosive atmospheres – Part 18: Equipment protection by encapsulation “m”*

IEC STANDARDS

International Electrotechnical Commission

- IEC 60079-1A-1975, Amendment No. 1 (1993), *Construction and verification tests of flameproof enclosures of electrical apparatus*
- IEC 60079-10-1995, *Electrical Apparatus for Explosive Gas Atmospheres, Classification of Hazardous Areas*
- IEC 60079-11-1999, *Electrical apparatus for explosive gas atmospheres – Part 11: Intrinsic safety “i”*
- IEC 60079-12-1978, *Classification of mixtures of gases or vapours with air according to their maximum experimental safe gaps and minimum*
- IEC 60079-13-2010, *Electrical Apparatus for explosive gas atmospheres – Part 13: Construction and use of rooms or buildings protected by pressurization*
- IEC 60079-14-1996, *Electrical apparatus for explosive gas atmospheres – Part 14: Electrical installations in explosive gas atmospheres (other than mines)*
- IEC 60079-16-1990, *Electrical apparatus for explosive gas atmospheres – Part 16: Artificial ventilation for the protection of analyzer(s) houses ignition currents*
- IEC 60079-20-1996, *Electrical Apparatus for Explosive Gas Atmospheres, Data for Flammable Gases and Vapours, Relating to the Use of Electrical Apparatus*

OTHER STANDARDS

- ANSI/ASHRAE 15-1994, *Safety Code for Mechanical Refrigeration*
- ANSI/CGA G2.1-1989, *Safety Requirements for the Storage and Handling of Anhydrous Ammonia*
- ANSI/NEMA 250-2008, *Enclosures for Electrical Equipment*

APPENDIX B-2: NEMA ENCLOSURE DEFINITIONS

NON-CLASSIFIED LOCATION ENCLOSURES.

- NEMA enclosures 2, 5, 12, 12K and 13 are not intended to provide protection against conditions such as internal condensation. NEMA enclosures 3, 3X, 3R, 3RX, 3S, 3SX, 4, 4X, 6 and 6P are not intended to provide protection against conditions such as internal condensation or internal icing.
- **Type 1 Enclosures.** Type 1 enclosures are intended for indoor use primarily to provide a degree of protection against limited amounts of falling dirt in locations where unusual service conditions do not exist.
- **Type 2 Enclosures.** Type 2 enclosures are intended for indoor use primarily to provide a degree of protection against limited amounts of falling water and dirt.
- **Type 3 Enclosures.** Type 3 enclosures are intended for outdoor use primarily to provide a degree of protection against rain, sleet, and wind-blown dust; and to be undamaged by the formation of ice on the enclosure.
- **Type 3X Enclosures.** Type 3X enclosures are intended for outdoor use primarily to provide a degree of protection against rain, sleet, and wind blown dust; and to be undamaged by the formation of ice on the enclosure. These enclosures also provide an additional level of protection against corrosion.
- **Type 3R Enclosures.** Type 3R enclosures are intended for outdoor use primarily to provide a degree of protection against rain and sleet; and to be undamaged by the formation of ice on the enclosure. They must have a provision for a drain hole.
- **Type 3RX Enclosures.** Type 3RX enclosures are intended for outdoor use primarily to provide a degree of protection against rain and sleet; and to be undamaged by the formation of ice on the enclosure. They must have a provision for a drain hole. These enclosures also provide an additional level of protection against corrosion.
- **Type 3S Enclosures.** Type 3S enclosures are intended for outdoor use primarily to provide a degree of protection against rain, sleet, and windblown dust, and to provide for operation of external mechanisms when ice laden.
- **Type 3SX Enclosures.** Type 3SX enclosures are intended for outdoor use primarily to provide a degree of protection against rain, sleet, and windblown dust, and to provide for the operation of external mechanisms when ice laden. These enclosures also provide an additional level of protection against corrosion.
- **Type 4 Enclosures.** Type 4 enclosures are intended for indoor or outdoor use primarily to provide a degree of protection against windblown dust and rain, splashing water, and hose-directed water; and to be undamaged by the formation of ice on the enclosure.
- **Type 4X Enclosures.** Type 4X enclosures are intended for indoor or outdoor use primarily to provide a degree of protection against corrosion, windblown dust and rain, splashing water, and hose-directed water; and to be undamaged by the formation of ice on the enclosure.
- **Type 5 Enclosures.** Type 5 enclosures are intended for indoor use primarily to provide a degree of protection against settling airborne dust, falling dirt, and dripping noncorrosive liquids.
- **Type 6 Enclosures.** Type 6 enclosures are intended for indoor or outdoor use primarily to provide a degree of protection against hose-directed water and the entry or water during temporary submersion at a limited depth; and to be undamaged by the formation of ice on the enclosure.

- **Type 6P Enclosures.** Type 6P enclosures are intended for indoor or outdoor use primarily to provide a degree of protection against hose-directed water and the entry of water during prolonged submersion at a limited depth; and to be undamaged by the formation of ice on the enclosure.
- **Type 12 Enclosures.** Type 12 enclosures are intended for indoor use primarily to provide a degree of protection against circulating dust, falling dirt, and dripping noncorrosive liquids.
- **Type 12K Enclosures.** Type 12K enclosures are intended for indoor use primarily to provide a degree of protection against circulating dust, falling dirt, and dripping noncorrosive liquids. The knockouts shall be provided only in the top or bottom walls, or both.
- **Type 13 Enclosures.** Type 13 enclosures are intended for indoor use primarily to provide a degree of protection against lint, dust, spraying of water, oil, and noncorrosive coolant.

CLASSIFIED LOCATION ENCLOSURES.

- **Type 7 Enclosures.** Type 7 enclosures are for indoor use in hazardous (classified) locations as Class I, Division 1, Groups A, B, C, or D, as defined in the *National Electrical Code*.
- **Type 8 Enclosures.** Type 8 enclosures are for indoor or outdoor use in hazardous (classified) locations as Class I, Division 1, Groups A, B, C, or D, as defined in the *National Electrical Code*.
- **Type 9 Enclosures.** Type 9 enclosures are intended for indoor use in hazardous (classified) locations as Class II, Division 1, Groups E, F, and G, as defined in the *National Electrical Code*.
- **Type 10 Enclosures (MSHA).** Type 10 enclosures shall be capable of meeting the requirements of the Mine Safety and Health Administration, *30 C.F.R.*, Part 18.



APPENDIX B-3: COMPARISON BETWEEN NEMA ENCLOSURE TYPE NUMBERS AND IEC ENCLOSURE CLASSIFICATION DESIGNATIONS

IEC Publication 60529 “Classification of Degrees of Protection Provided by Enclosures” provides a system for specifying the enclosures of electrical equipment on the basis of the degree of protection provided by the enclosure. IEC 60529 does not specify degrees of protection against mechanical damage of equipment, risk of explosions, or conditions such as moisture (produced for example by condensation), corrosive vapors, fungus, or vermin. The NEMA Standard for Enclosures for Electrical Equipment does test for environmental conditions such as corrosion, rust, icing, oil, and coolants. For this reason, and because the test and evaluations for other characteristics are not identical, the IEC Enclosure Classification Designations cannot be exactly equated with NEMA Enclosure Type numbers.

The IEC designation consists of the letters IP followed by two numerals. The first characteristic numeral indicates the degree of protection provided by the enclosure with respect to persons and solid foreign objects entering the enclosure. The second characteristic numeral indicates the degree of protection provided by the enclosure with respect to the harmful ingress of water.









The following table provides an understanding as to the specific characteristic that an IP defines.

UNDERSTANDING THE INGRESS PROTECTION SYSTEM

IP

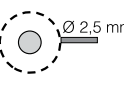
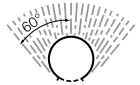
The IEC IP classification system designates the degree of protection provided by an enclosure against impact and/or water or dust penetration (ingress). It has two numbers; first—protection against solid objects, second—protection against liquid.

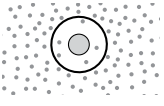
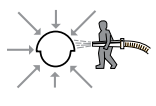
EXAMPLE: IP 54

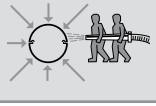
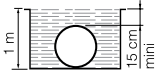
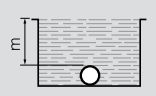
1 ST FIGURE: protection against solid bodies			2 ND FIGURE: protection against liquids		
IP	TESTS		IP	TESTS	
0	No protection		0	No protection	
1		Protected against solid bodies larger than 50 mm (e.g. accidental contact with the hand)	1		Protected against vertically-falling drops of water (condensation)
2		Protected against solid bodies larger than 12.5 mm (e.g. finger of the hand)	2		Protected against drops of water falling at up to 15° from the vertical
3		Protected against solid bodies larger than 2.5 mm (tools, wires)	3		Protected against drops of rainwater at up to 60° from the vertical
4		Protection against solid bodies larger than 1 mm (fine tools, small wires)	4		Protected against projections of water from all directions
5		Protected against dust (no harmful deposit)	5		Protected against jets of water from all directions
6		Completely protected against dust	6		Completely protected against jets of water of similar force to heavy seas
			7		Protected against the effects of temporary immersion
			8		Protected against effects of prolonged immersion under specified conditions

APPENDIX B-3: COMPARISON BETWEEN NEMA ENCLOSURE TYPE NUMBERS AND IEC ENCLOSURE CLASSIFICATION DESIGNATIONS

The following table provides an equivalent conversion from NEMA enclosure Type numbers to IEC Enclosure Classification Designations. The NEMA type numbers should be considered to meet or exceed the test requirements for the associated IEC Classification. This table cannot be used to convert from IEC Classifications to NEMA Enclosure Type numbers.

Reference: NEMA 250-2003, Enclosures for Electrical Equipment (1000 Volts Maximum).

Approximation of NEMA Enclosure Type numbers to IEC Classification Designations

(Cannot be used to convert IEC Classification Designations to NEMA Type numbers)

NEMA ENCLOSURE	
Type Number	IEC Enclosure Classification Designation
1	IP21
2	IP22
3	IP55
3X	IP55
3R	IP24
3RX	IP24
3S	IP55
3SX	IP55
4 and 4X	IP66
5	IP53
6 and 6P	IP67
12 and 12K	IP54
13	IP54

APPENDIX C: STANDARDS, TESTING AND CERTIFICATION

AMERICAN NATIONAL STANDARDS INSTITUTE (ANSI).

- The Institute oversees the creation, promulgation and use of thousands of norms and guidelines that directly impact businesses in nearly every sector: from acoustical devices to construction equipment, from dairy and livestock production to energy distribution, and many more. ANSI is also actively engaged in accrediting programs that assess conformance to standards – including globally-recognized cross-sector programs such as the ISO 9000 (quality) and ISO 14000 (environmental) management systems.

INSTITUTE OF ELECTRICAL AND ELECTRONICS ENGINEERS (IEEE).

- IEEE's core purpose is to foster technological innovation and excellence for the benefit of humanity.

INTERNATIONAL SOCIETY OF AUTOMATION.

- ISA develops standards; certifies industry professionals; provides education and training; publishes books and technical articles; and hosts conferences and exhibitions for automation professionals. ISA is the founding sponsor of the Automation Federation.

INTERTEK TESTING SERVICES (ITS).

- ITS is an OSHA Certified Nationally Recognized Testing Laboratory (NRTL). The ITS mark for electrical safety is the ETL mark.

AMERICAN PETROLEUM INSTITUTE (API).

- This organization publishes Recommended Practice for Classification of Locations for Electrical Installations in Petroleum Facilities (API RP 500).

NATIONAL ELECTRICAL MANUFACTURERS ASSOCIATION (NEMA).

- NEMA issues standards on electrical equipment on all major categories of electrical equipment. Generally where construction and performance relate to safety, reference is made to standards of others, such as Underwriters Laboratories Incorporated. The widely recognized NEMA enclosure types are described in NEMA's Standard Publication/No. 250.

INTERNATIONAL ELECTROTECHNICAL COMMISSION (IEC).

- This organization is comprised of approximately forty member countries, including the United States. The purpose of the IEC is to establish standards for a wide variety of electrical products to encourage international trade. IEC publication series 79, entitled Electrical Apparatus for Explosive Gas Atmospheres, consists of several parts covering area classification, test apparatus and several techniques used for protection of apparatus, intended for use in hazardous locations.

OCCUPATIONAL SAFETY AND HEALTH ADMINISTRATION (OSHA).

- OSHA mandates the use of electrical equipment that has been verified by Nationally Recognized Test Labs (NRTLs) as being suitable for the application. Some units of a system installation are not necessarily NRTL certified if such certification is judged not applicable. All products involved must meet *NEC*® requirements, as interpreted by OSHA.

OTHER ASSOCIATIONS.

- Professional and technical organizations develop and/or sponsor standards as product guidelines, application recommendations, safety rules or test methods. Typical associations include the American Iron and Steel Institute (AISI), the Aluminum Association (AA), the Illuminating Engineering Society (IES) and the Edison Electric Institute (EEI).

UNDERWRITERS LABORATORIES, INC. (UL).

- UL is an OSHA Certified Nationally Recognized Testing Laboratory (NRTL). In addition to specific UL Standards, UL publishes a "Green" book, an "Orange" book and a "Red" book. These three books contain the names of companies who have qualified to use the Listing or Classification Marking of Underwriters Laboratories on products which have been found to be in compliance with applicable UL requirements. The "Green" book, entitled Electrical Construction Materials Directory, contains detailed information on Listed electrical devices generally considered as construction materials, and for use by electricians or others in the electrical industry. The "Orange" book, entitled Electrical Appliance and Utilization Equipment Directory, contains detailed information on Listed appliances or other similar equipment generally considered for use by the general public. The "Red" book, entitled Hazardous Location Equipment Directory, contains detailed information on Listed equipment intended for use in hazardous locations as defined by Article 500 of the *National Electrical Code*. These three publications can be used to obtain the names of companies who have a Listing in a specific product category, and to obtain information regarding the scope, limitations, or special conditions of a particular product category.

LOCAL BUILDING CODES.

- These codes influence and determine ultimate decisions on product suitability. *NEC*® Article 100 provides this definition: "APPROVED: Acceptable to authority having jurisdiction."

MANUFACTURERS DATA.

- Manufacturers such as Appleton Group, working with recognized organizations, develop and improve products for third party certification and thus set additional product suitability standards.
- Standards set by such organizations as Underwriters Laboratories (UL) and Canadian Standards Association (CSA) identify the criteria used by Appleton in the design and company testing of its products. These Third Party standards evolved over the years as manufacturing and processing became more complex and more hazardous.

APPENDIX C: STANDARDS, TESTING AND CERTIFICATION

NATIONAL FIRE PROTECTION ASSOCIATION (NFPA).

- One of the pioneering organizations to set standards for the wiring and control of electricity was the National Fire Protection Association. Formed in 1896, the NFPA is composed of national and regional groups, plus individuals, firms and institutions interested in protecting life and property. This organization sets minimum standards to form a *National Electrical Code (NEC)*, which is used as a criteria for insurance, state and civic inspectors when making inspections or recommendations for electrical installations. Typical member organizations of the NFPA are the National Electrical Manufacturers Association, American Petroleum Institute, Institute of Electrical and Electronic Engineers, American Institute of Architects, Underwriters Laboratories, Inc., Factory Mutual, American Insurance Association, and many fire underwriting groups.
- Appleton designs and tests its products to meet or exceed the standards established by Third Party Certifiers.

CANADIAN STANDARDS ASSOCIATION (CSA).

- CSA is an OSHA Certified Nationally Recognized Testing Laboratory (NRTL). CSA has established standards similar to UL for the testing of electrical products. Thousands of Appleton products marketed in the USA are both UL Listed and CSA Certified. All products manufactured by Appleton Electric Limited (Canada) meet or exceed CSA standards and most are CSA certified.

FACTORY MUTUAL (FM).

- FM is an OSHA Certified Nationally Recognized Testing Laboratory (NRTL). FM is a non-profit third party testing and certification organization, providing many of the same services as UL. FM uses three broad standards: 3611, 3615 and 3616. In addition, FM tests and approves products not covered by these standards.

APPLETON'S CERTIFICATION POLICY.

- In each section of the Appleton Catalog under "Compliances," the appropriate published UL Standard is shown. This number signifies that the products in that section meet or exceed the requirements of that UL Standard. The term "Compliances" does not necessarily mean that the products are UL Listed. UL approval is a matter of independent record, signified by product nameplate or carton marking and can be ascertained by referring to approved sources. Although the majority of Appleton products are UL Listed, there are instances where this is impractical. For example, a product may not be UL Listed because it is a subassembly, such as a mounting box. Often a product is not UL Listed because it is in the process of being approved by UL. Due to technical problems in presentation, most of the Appleton UL Listed products are not so indicated in the Appleton Catalog, but information regarding UL approvals on any specific product is obtainable upon request. Appleton has thousands of UL Listed products. In addition all other NRTL and/or IEC standards and compliances are also listed.

NORTH AMERICAN CERTIFICATION.

- The United States and Canada are both members of the IECEx Conformity Assessment System. As a result for Hazardous Location Certification UL and CSA accepts each other's data for purpose of providing their National Certification Marks. This applies when the Essential Requirements of both countries are the same.

APPENDIX D: QUICK SELECTION GUIDE – EQUIPMENT FOR HAZARDOUS LOCATIONS

Product Category	Class I, Division 1; Class I, Zone 1	Class I, Division 2; Class I, Zone 2	Class II, Division 1 & 2 Group E, F, G; Class II, Zone 21 and 22	Class II, Division 2 Group F & G; Class III, Division 1 & 2; Class II, Zone 22
Conduit Outlet Boxes (Cast)				
CPU	X		X	X
ELBD	X		X	X
ELBY	X		X	X
ER	X		X	X
GR	X		X	X
GRF	X		X	X
GRH	X		X	X
GRJ	X		X	X
GRJS	X		X	X
GRSS/GRSSA	X		X	X
GRU/GRUE	X		X	X
GRUJ	X		X	X
GRUO	X		X	X
FM8		X		
Big Bend (BB)		X		
FM7		X		
FM9		X		
Form 35		X		
Form 85		X		
GSU		X		
JB/JBD/JBLX		X		
LBDN/LBD		X		
Mogul		X		
PTB/PTC		X		
SEH		X		
Junction Boxes (Cast)				
ACSEW	X		X	
AETE	X		X	
AGUB	X		X	
AJBEW	X		X	
DTX			X	
EXB	X		X	
GUBB	X		X	
GUBBD	X		X	
GUBBM	X		X	
RS		X		
W Series		X		
Plugs and Receptacles				
ACP ①	X			
CES/CESD	X			
CPH	X			
CPS/CPC	X			
DBR			X	X
EBR/EBRH	X		X	X
ECC ④			X	X
ECP	X			
EFS	X			

① When used with JBR, EBR receptacles.

② Suitable if installed in compliance with NEC® 501.130(B)(3).

③ Suitable if installed in compliance with NEC® 502.10(A)(2).

④ Suitable for Group G only.

⑤ Temperature restrictions apply. Please refer to the Appleton Master Catalog for complete information.

APPENDIX D: QUICK SELECTION GUIDE – EQUIPMENT FOR HAZARDOUS LOCATIONS

Product Category	Class I, Division 1; Class I, Zone 1	Class I, Division 2; Class I, Zone 2	Class II, Division 1 & 2 Group E, F, G; Class II, Zone 21 and 22	Class II, Division 2 Group F & G; Class III, Division 1 & 2; Class II, Zone 22
EFSR-GFI	X		X	X
ENR	X		X	X
ENRC	X			
FP	X		X	X
FSQC	X		X	X
FSQX	X		X	X
JBR	X			
N1 (U-Line®)	X		X	X
NCP	X		X	X
ACP	X	X	X	X
ECP	X	X		
MD2SR	X	X	X	X
N2 (U-Line®)	X	X	X	X
NCP	X	X		
Powertite			X	
WSR			X	
WSRD			X	
Luminaires (LED, HID, Incandescent, Fluorescent)				
A-51	X		X	
AHL	X		X	
APL	X		X	
Code•Master 2	X		X	
Code•Master 2 Floodlight	X			
Code•Master Jr.	X		X	
Code•Master Strobe and Beacon	X			
DRS			X	
EDTP			X	
EFU	X		X	
EHL-N	X			
ELS Series	X			
G-EFJB/WB	X			
PAPL	X			
Areamaster I/2		X		
Areamaster LED		X		
Corrofflood		X		
FD Series		X		
FV Series		X		
Mercmaster II		X	X	X ⑤
Mercmaster III		X	X	X ⑤
Mercmaster III 400		X	X	X ⑤
Mercmaster III Emergency		X	X	X ⑤
Mercmaster III Low Profile		X	X	X ⑤
Mercmaster Jr.		X	X	X ⑤
Mercmaster LED		X		
N2LS		X		
Stylemaster Strobe and Beacon		X	X	X ⑤
Viamaster		X		

① When used with JBR, EBR receptacles.

② Suitable if installed in compliance with NEC® 501.130(B)(3).

③ Suitable if installed in compliance with NEC® 502.10(A)(2).

④ Suitable for Group G only.

⑤ Temperature restrictions apply. Please refer to the Appleton Master Catalog for complete information.

APPENDIX D: QUICK SELECTION GUIDE – EQUIPMENT FOR HAZARDOUS LOCATIONS

Product Category	Class I, Division 1; Class I, Zone 1	Class I, Division 2; Class I, Zone 2	Class II, Division 1 & 2 Group E, F, G; Class II, Zone 21 and 22	Class II, Division 2 Group F & G; Class III, Division 1 & 2; Class II, Zone 22
Fixture Hangers				
CPU	X		X	X
EFHC	X		X	X
EFHCA	X		X	X
EFHM/F	X		X	X
EFHU	X		X	X
ESD/ESS	X		X	X
EXJF	X		X	X
GRF/GRK	X		X	X
AHG Cushion ②	X	X		
GS Cushion ②	X	X		
JB Cushion ②	X	X		
Control Stations and Pilot Lights				
Contender—Div. 1	X	X	X	X
Contender—Div. 2		X	X	X
EDS/EDSC	X		X	X
EFD	X		X	X
EFDB	X		X	X
EFDL/T	X			
EFS	X		X	X
N1	X			
N2		X	X	X
UniCode - UCS		X	X	X
Unicode 2		X		
Switches				
AFAX	X		X	X
AFSX	X		X	X
AFUX	X		X	X
Contender—Div. 1	X		X	X
EDS & EFS	X		X	X
EDS Disconnect	X		X	X
GUSC	X		X	X
N1	X			
FD2 Series	X	X		
MD2DS	X	X		
WST ③				X
Motor Starters, Circuit Breakers and Manual Contractors				
AE Series (Bolted)	X	X	X	X
AE Series (Threaded)	X	X	X	X
AEB Series (Bolted)	X	X	X	X
AEXMS	X	X	X	X
EB1/2/3	X	X	X	X
EDS			X	X
EFD			X	X
N1	X	X		

① When used with JBR, EBR receptacles.

② Suitable if installed in compliance with NEC® 501.130(B)(3).

③ Suitable if installed in compliance with NEC® 502.10(A)(2).

④ Suitable for Group G only.

⑤ Temperature restrictions apply. Please refer to the Appleton Master Catalog for complete information.

APPENDIX D: QUICK SELECTION GUIDE – EQUIPMENT FOR HAZARDOUS LOCATIONS

Product Category	Class I, Division 1; Class I, Zone 1	Class I, Division 2; Class I, Zone 2	Class II, Division 1 & 2 Group E, F, G; Class II, Zone 21 and 22	Class II, Division 2 Group F & G; Class III, Division 1 & 2; Class II, Zone 22
Panelboards				
AGPN	X		X	X
ALPF	X		X	X
ALPN	X		X	X
APPF	X		X	X
APPN	X		X	X
EWP	X		X	X
D2P				
XP	X	X		
Sealing Hubs, Unions, Seals, Flex Couplings, Drain/Breather, Reducing Bushings, Bell Reducers				
BR	X		X	X
BRTB	X			
CN Series	X	X		
ECDB	X		X	X
EL	X		X	X
ES	X		X	X
ESUF/M	X		X	X
EXGJH/EXLK	X		X	X
EYD	X			
EYDEF	X		X	X
EYDM	X		X	X
EYF/M	X		X	X
EYS	X			
EYSEF	X		X	X
EYSF/M	X		X	X
PLG	X			
RB	X		X	X
UNA	X		X	X
UNL	X		X	X
UNY/UNF	X		X	X
Conduit Hubs, Conduit Hangers, Liquidtight Connectors, Cable Connectors, Cable Tray Clamps, Cord Reels				
AERL	X			
CG ③	X	X	X	X
CH	X	X	X	X
HUB	X	X		
RL 200E-500E	X			
RW300E-500E	X			
ST/STN	X	X	X	X
STB	X	X	X	X
STL	X	X	X	X
STNM ③	X	X	X	X
TCC, TCCD	X		X	X
TMC/TMC2	X	X		
TMCX/TMC2X	X	X	X	X

① When used with JBR, EBR receptacles.

② Suitable if installed in compliance with NEC® 501.130(B)(3).

③ Suitable if installed in compliance with NEC® 502.10(A)(2).

④ Suitable for Group G only.

⑤ Temperature restrictions apply. Please refer to the Appleton Master Catalog for complete information.

APPENDIX E-1: LIGHTING AND POWER DIAGRAMS: CLASS I, DIVISION 1 AND 2, GROUP B; CLASS I, ZONES 1 AND 2, GROUPS IIA, IIB+ H₂ [∅]

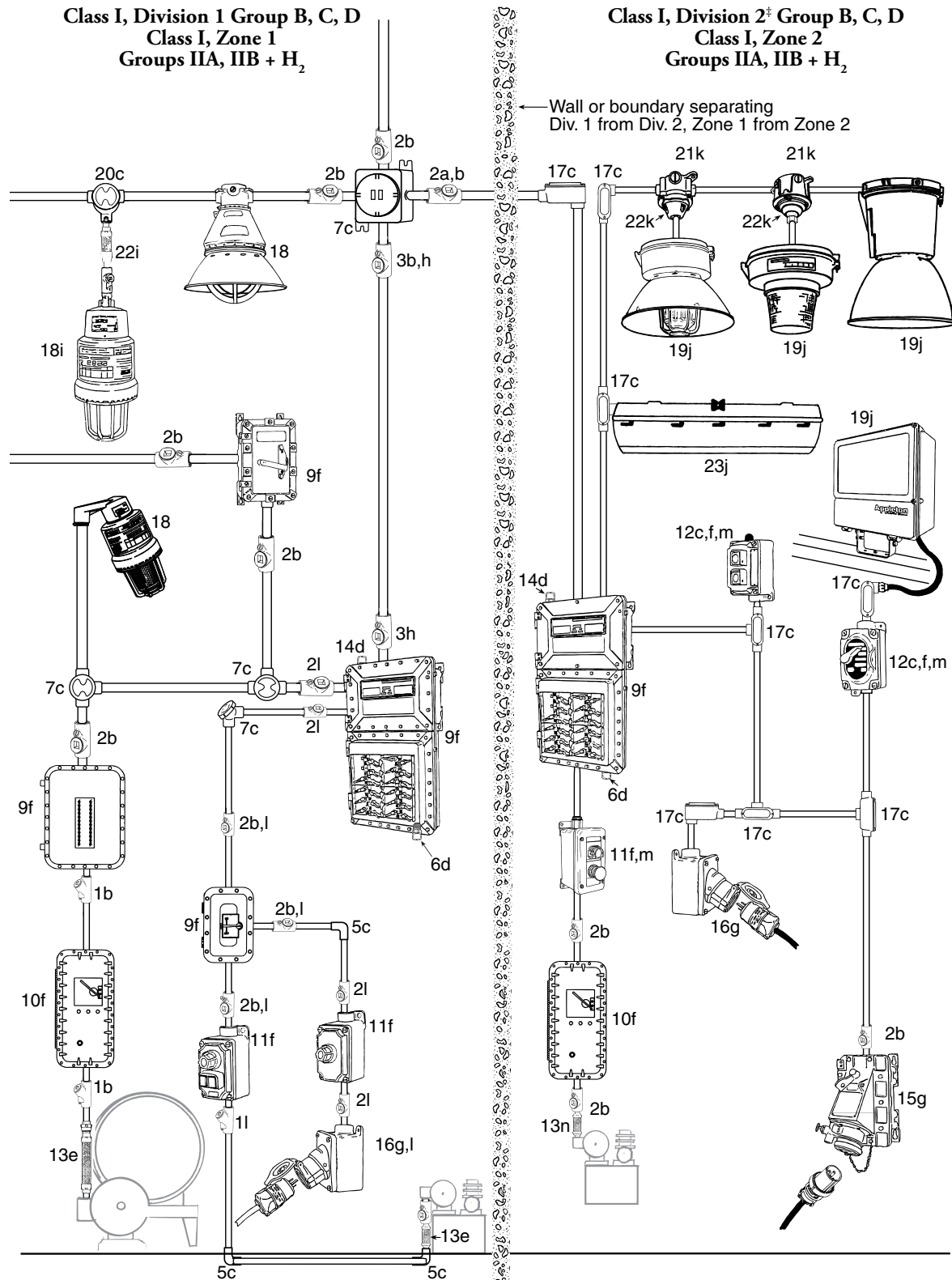

For Class I, Division 2 locations seals are required when using 2" trade size or larger where splices or taps are contained.
[∅] Refer to Section 505.9(C)(1).
[‡] All items shown in Division 1 are also suitable for Division 2.

APPENDIX E-1: LIGHTING AND POWER DIAGRAMS: CLASS I, DIVISION 1 AND 2, GROUP B; CLASS 1, ZONES 1 AND 2, GROUPS IIA, IIB+ H₂[◇]

Key to Product[†]

- 1— Sealing Fitting. EYSF/M, EYS—used with vertical conduits.
- 2— Sealing Fittings. EYF/M, EYS series—used for sealing vertical or horizontal conduits.
- 3— Sealing Fitting, expanded fill. EYSEF, EYDEF.
- 4— Union, UNY-NR, UNF-NR, UNL.
- 5— Elbows. ELF, ELMF, ELMFL.
- 6— Drain. DRNB4X, ECDB50B.
- 7— Explosionproof Junction Boxes. GR, GU, GRH, GRF, ELBY, GRSS, GUBB, with threaded covers. See “I” opposite.
- 8— Explosionproof Junction Boxes, AJBEW, with ground surface covers.
- 9— Panelboards, Circuit Breaker, ALPN, APPN, AGPN, APPF, D2P, EWP, Manual Starter, Disconnect Switch, AE, EB, EDS, MD2DS.
- 10— Combination Circuit Breaker and Line Starter. AEB Series, bolted cover.
- 11— Push Button/Pilot Light, factory sealed. Division 1—EDS, EFDB, Division 2 only—EFS Division 2 Contender, UniCode, N2.
- 12— Switch/Motor Starter, factory sealed. Division 1—EDS, EFDB. Factory sealed switch Division 2—FDK2.
- 13— Flexible Coupling. EXGJH, EXLK, liquidtight connector.
- 14—Breather. BRTB4X, ECDB50B.
- 15— Receptacle, non-factory sealed, interlocked. FSQC, JBR, EBRH.
- 16— Receptacle, EFSB, EFS requires seal for Group B, Division 1. See “I” opposite.
- 17— Conduit Boxes, Bodies, Fittings. Form 35, Form 85, FM7, FM8, FM9, Mogul, JB, GSU, LBD.
- 18— Luminaires, Division 1—CodeMaster Jr., AAPA.
- 19— Luminaires, Division 2—HID—Mercmaster III, Mercmaster II, Mercmaster III Low Profile, Areamaster I/2, Corrolood.
- 20— Fixture Hangers, Division 1—EFHC, EFHCA.
- 21— Fixture Hangers, Division 2—JB, GSU.
- 22— Flexible Fixture Supports, Division 1—EXJF; Division 2—JB Cushion, AHG Cushion, GS Cushion.
- 23— Luminaires. Division 2—Fluorescent, FV Series.

National Electric Code[®] Reference

- a— *Sec. 501.15(A)(4)* Seal required (within 10 feet) on either side of boundary entering or leaving hazardous area
- b— *Sec. 501.15(A)(1)* Seals required within 18 inches of all arcing devices.
- c— *Sec. 501.10(A) and (B) and 500.8(D)* In Division 1, boxes and fittings must be explosionproof and have 5 full threads (4-1/2 when factory threaded) engaged. Permitted wiring methods include Threaded RMC, Threaded IMC, Listed MI cable/fittings, and Listed MC-HL cable with Listed cable connectors. In Division 2, boxes and fittings are not required to be explosionproof unless the enclosure contains arcing (contacts), sparking or heatproducing devices. Permitted wiring methods include all those for Division 1 such as Threaded RMC, Threaded IMC, and Listed MC-HL cable with Listed cable connectors. Also a variety of additional cable and raceway systems are permitted including MC cable with approved MC cable connectors.
- d— *Sec. 501.15(F)(1)* Drain/Breathers must be installed to prevent accumulation of liquids or condensed vapors.
- e— *Sec. 501.10(A)(2)* Flexible connections as at motor terminals must be explosionproof and listed for Class I, Division 1 locations.
- f— *Sec. 501.115* Panelboards, circuit breakers, push buttons, switches, motor controllers—shall be explosionproof and approved for Class I, Division 1 locations.
- g— *Sec. 501.145* Receptacles and plugs must be explosionproof, Group B approved and provide grounding conductor for portable equipment.
- h— *Sec. 501.15(C)(6)* Approved expanded fill seals permit up to 40% fill of cross sectional area of conduit.
- i— *Sec. 501.130(A)(1) and (3)* Lighting fixtures in Division 1 must be identified for the Class I, Division 1 location and if stem exceeds 12 inches it must be braced or have a flexible connector.
- j— *Sec. 501.130(B)(1)* In Division 2, fixtures must be tested and marked as to operating temperature or temperature range.
- k— *Sec. 501.130(B)(3)* In Division 2, hangers must be effectively braced or provide flexibility in the form of an identified fitting or flexible connector.
- l— For Division 1 listings, some products require seals installed immediately adjacent. See catalog for exact distance (can vary by product).
- m— *Sec. 501.15(A)(1)* Seals shall not be required in Class I, Division 1 and 2 locations if switches (contacts) are enclosed within a factory sealed explosionproof chamber.
- n— *Sec. 501.10(B)(2)* Class I, Division 2 flexible connections as at motor terminals can be flexible metal conduit (indoors), liquidtight flexible metal conduit, or liquidtight flexible nonmetallic conduit with listed fittings.

[◇] Refer to Section 505.9(C)(1).

[†] Not every size and style of mentioned series is suitable for Group B.

See General Catalog for specific listings.

APPENDIX E-2: POWER DIAGRAM: CLASS I, DIVISION 1, GROUPS C, D; CLASS I, ZONE 1, GROUPS IIA, IIB[∅]

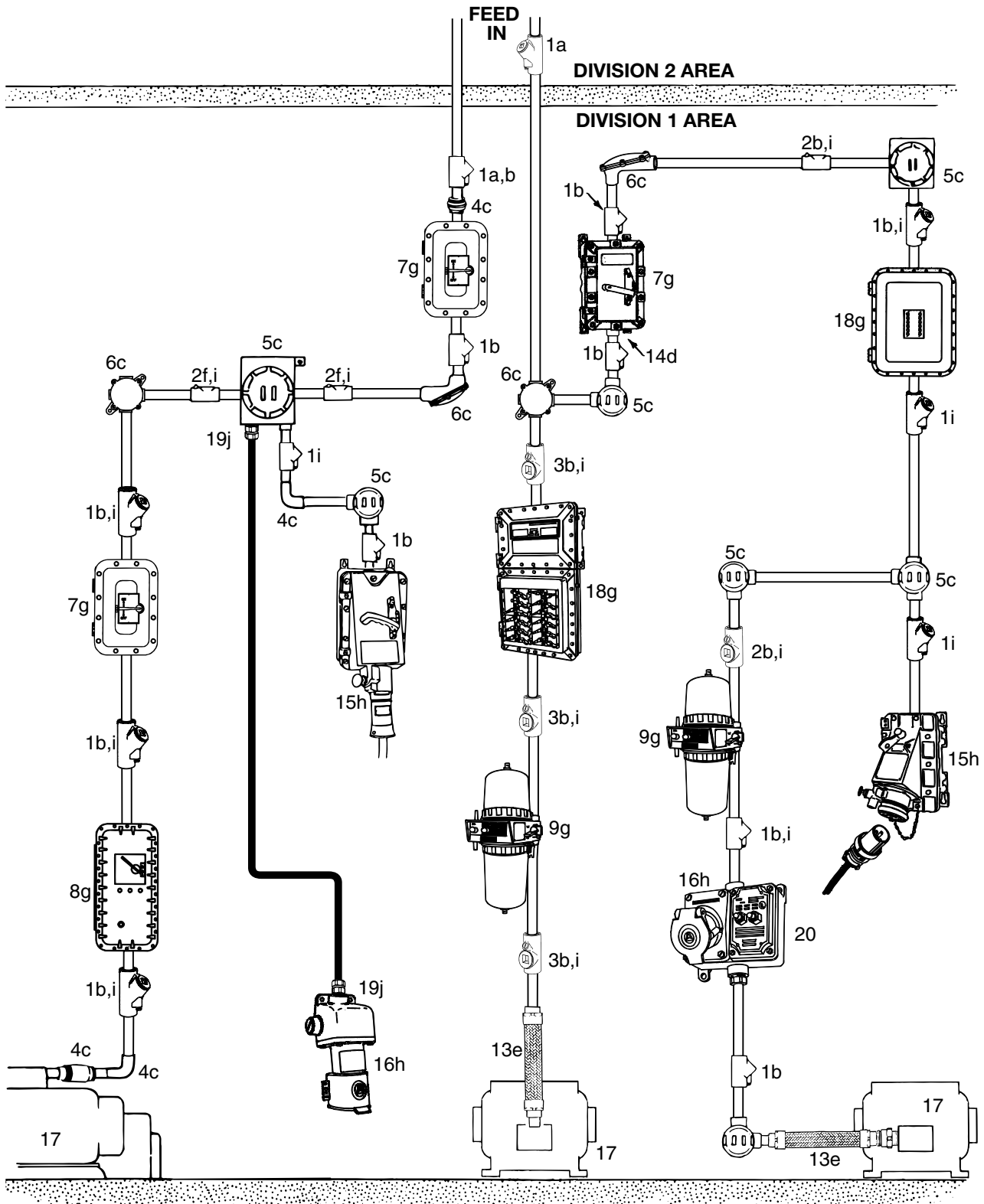

[∅] Refer to Section 505.9(C)(1).

APPENDIX E-2: POWER DIAGRAM: CLASS I, DIVISION 1, GROUPS C, D; CLASS I, ZONE 1, GROUPS IIA, IIB[◇]

Key to Product

- 1— Sealing Fitting. EYSF/M, EYS 1, 2, 3, 16, 26, 36—used with vertical conduits.
- 2— Sealing Fittings. EYF/M, EYS, EYD, EYDM, ESUF/M—used with vertical or horizontal conduits.
- 3— Sealing Fittings, expanded fill. EYSEF, EYDEF.
- 4— Unions/Elbows. UNY-NR, UNF-NR, UNY/F UNL, UNYL/UNFL; ELF, ELMF,UNA.
- 5— Explosionproof Junction Boxes. GR, GRSS, GRF, GUBB, GRU, GRUE, GU, ELBY, with threaded covers.
- 6— Explosionproof Junction Boxes. ELBD[‡], CPU, ER, AJBEW, with ground surface covers.
- 7— Circuit Breaker/Disconnect Switch/Manual Starters. AE-Series, AEXMS, EDS, EFS, N1.
- 8— Combination Circuit Breaker and Line Starter. AEB bolted cover.
- 9— Combination Line Starter and Circuit Breaker. AE threaded cover.
- 10— Push Button/Pilot Light, factory sealed. EDS, EFDB, EFD, EFS/D Contender.
- 11— Push Button, non-factory sealed. N1, EFD, OFC.
- 12— Switch/Motor Starter, factory sealed. EFD, EDS, EFDB.
- 13— Flexible Connector. EXGJH, EXLK.
- 14— Drain/Breather, combination. ECDB5OHP.
- 15— Receptacle, non-factory sealed. FSQC, JBR, EBR.
- 16— Receptacle, factory sealed. U-Line, EFS, CPS, CES, CESD[†].
- 17— Motor for Explosionproof Location.
- 18— Panelboards. EWP, ALPN, APPN, AGPN, APPF.
- 19— Type MC-HL Cable with TMCX Connectors, Listed for Class I, Division 1.
- 20— Ground Fault Interrupter (GFI) EFSRGFI, GFS1.

National Electric Code® Reference

- a— *Sec. 501.15(A)(4)* Seal required on either side of boundary (within 10 feet) entering or leaving hazardous area.
- b— *Sec. 501.15(A)(1)* Seals required within 18 inches of all arcing devices.
- c— *Sec. 501.10(A) and 500.8(D)* Boxes and fittings must be explosionproof and have 5 full threads (4-1/2 when factory threaded) engaged. Permitted wiring methods include Threaded RMC, Threaded IMC, Listed MI cable/fittings and Listed MC-HL cable with Listed cable connectors.
- d— *Sec. 501.15(F)(1)* Drain/breathers must be installed to prevent accumulation of liquids or condensed vapors.
- e— *Sec. 501.10(A)(2)* Flexible connections as at motor terminals must be explosionproof.
- f— *Sec. 501.10(A)(3)* All boxes, fittings and joints shall be approved for Class I, Division 1.
- g— *Sec. 501.115* Panelboards, circuit breakers, push buttons, switches, motor controllers—shall be explosionproof and approved for Class I, Division 1 locations.
- h— *Sec. 501.115* Receptacles and plugs must be explosionproof and provide grounding conductor for portable equipment.
- i— *Sec. 501.15(A)(1)(2)* Seals required if entries are trade size 2" or larger.
- j— *Sec. 501.15(D)(1)* Cable seals, Class I, Division 1.

[◇] Refer to Section 505.9(C)(1).

[‡] ELBD is suitable for Group D only.

[†] 60 Amp CES/CESD Suitable for Group D only.

APPENDIX E-3: LIGHTING DIAGRAM: CLASS I, DIVISION 1, GROUPS C, D; CLASS I, ZONE 1, GROUPS IIA, IIB^Ø

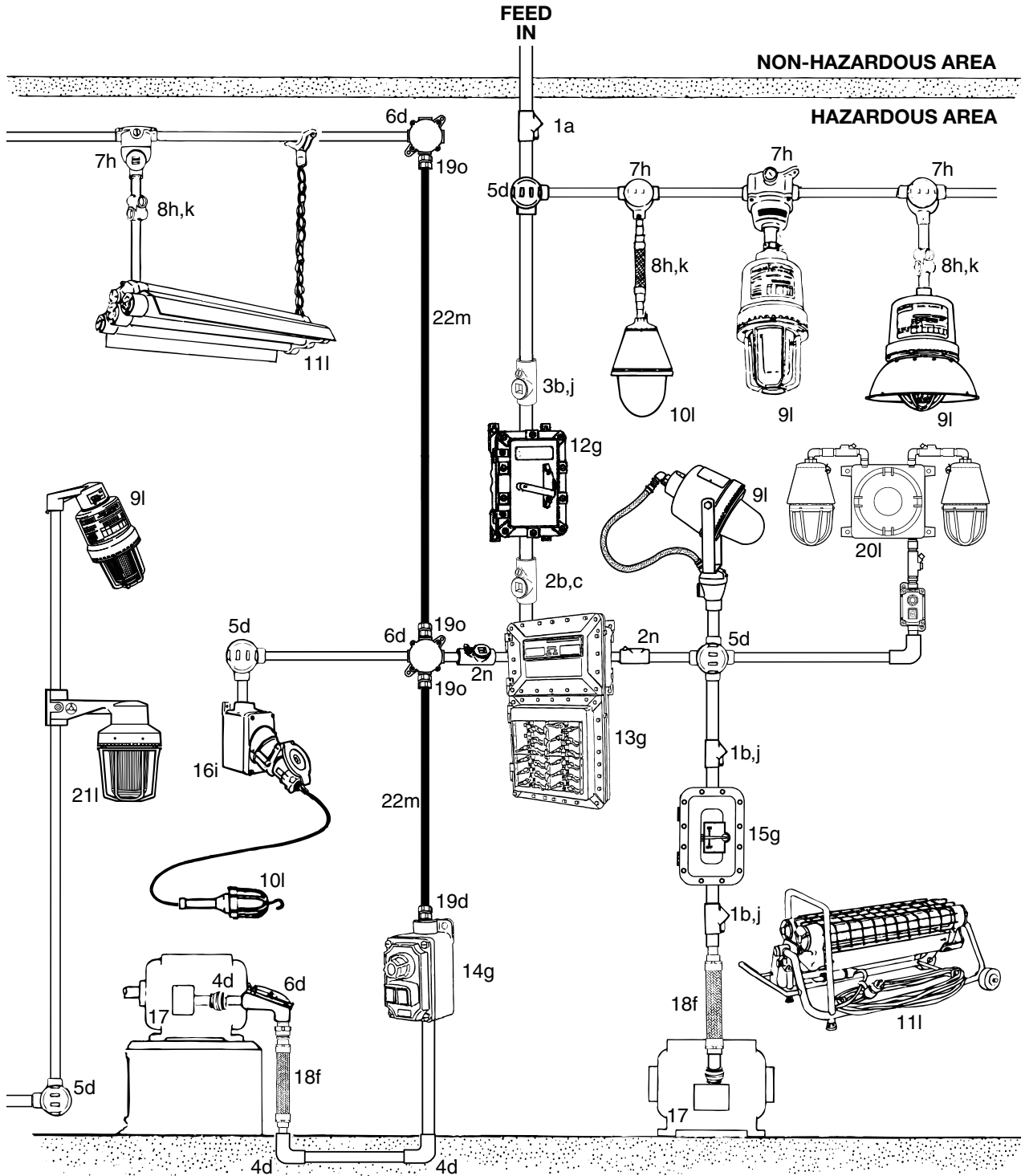

^Ø Refer to Section 505.9(C)(1).

APPENDIX E-3: LIGHTING DIAGRAM: CLASS I, DIVISION 1, GROUPS C, D; CLASS I, ZONE 1, GROUPS IIA, IIB[∅]

Key to Product

- 1— Sealing Fittings. EYSF/M, EYS 1, 2, 3, 16, 26, 36—used with vertical conduits.
- 2— Sealing Fittings. EYF/M, EYS, EYD, EYDM, ESUF/M—used with vertical or horizontal conduits.
- 3— Sealing Fittings, expanded fill. EYSEF, EYDEF.
- 4— Unions/Elbows. UNY-NR, UNF-NR, UNY/E, UNL, UNYL/UNFL; ELF, ELMF.
- 5— Explosionproof Junction Boxes. GR, GRSS, GRF, GUBB, GRU, GRUE, GU, with threaded covers.
- 6— Explosionproof Junction boxes. ELBD, CPU, AJBEW, with ground surface covers.
- 7— Fixture Hangers. CPU, EFHU, EFHC, GRF, FHS.
- 8— Flexible and Swivel Fixture Supports. EXJF, ESD, ESS.
- 9— Luminaires, HID. CodeMaster-2, Codemaster Jr., CodeMaster Flood.
- 10— Luminaires, Incandescent. A-51, EHL, G-EFWB.
- 11— Luminaires, Fluorescent. EFU, APL, PAPL.
- 12— Circuit Breaker. EB.
- 13— Panelboard, factory sealed. EWP.
- 14— Push Button/ Pilot Light, factory sealed. EDS, EFDB.
- 15— Switch/Manual Motor Starter. AEXMS, EDS Disconnect.
- 16— Receptacle, factory sealed, U-Line. EFS.
- 17— Motor for Hazardous Location.
- 18— Flexible Connector. EXGJH, EXLK.
- 19— TMCX Cable/Connectors, listed for Class I, Division 1.
- 20— Emergency Lighting System. ELS Series.
- 21— Strobe Warning Light. CodeMaster Strobe.
- 22— MC-HL armored/PVC jacketed cable.

National Electric Code® Reference

- a— *Sec. 501.15(A)(4)* Seal required on either side of boundary (within 10 feet) entering or leaving hazardous area.
- b— *Sec. 501.15(A)(1)* Seals required within 18 inches of all arcing devices.
- c— *Sec. 501.15(A)(1)* Seals required if conduit is Trade Size 2 or larger.
- d— *Sec. 501.10(A) and 500.8(D)* Boxes and fittings must be explosionproof and have 5 full threads (4-1/2 when factory threaded) engaged. Permitted wiring methods include Threaded RMC, Threaded IMC, Listed MI cable/fittings and Listed MC-HL cable with Listed cable connectors.
- e— *Sec. 501.15(F)(1)* Drain/breathers must be installed to prevent accumulation of liquids or condensed vapors.
- f— *Sec. 501.10(A)(2)* Flexible connections as at motor terminals must be explosionproof.
- g— *Sec. 501.115* Panelboards, circuit breakers, push buttons, switches, motor controllers—shall be explosionproof and approved for Class I, Division 1 locations.
- h— *Sec. 501.130(A)(4)* Boxes and fittings used for support of lighting fixtures shall be approved for Class I, Division 1 locations.
- i— *Sec. 501.145* Receptacles and plugs must be explosionproof and provide grounding conductor for portable equipment.
- j— *Sec. 501.15(C)(6)* Approved expanded fill seals permit up to 40% fill of cross sectional area of conduit.
- k— *Sec. 501.130(A)(3)* Pendant fixture stems must be threaded rigid or IMC conduit. Stems over 12 inches must be braced or have approved flexible connector.
- l— *Sec. 501.130(A)(1)* All lighting fixtures, both fixed and portable, must be approved for Class I, Division 1.
- m— *Sec. 501.10(A)(1)(c)* Where wiring methods allow MC-HL cable in industrial establishments with limited public access.
- n— For some applications products may require seals installed immediately adjacent. Refer to Catalog
- o— *Sec. 501.15(D)(1)* Cable seals, Class I, Division 1.

[∅] Refer to Section 505.9(C)(1).

APPENDIX E-4: LIGHTING AND POWER DIAGRAM: CLASS I, DIVISION 2, GROUPS C, D; CLASS I, ZONE 2, GROUPS IIA, IIB

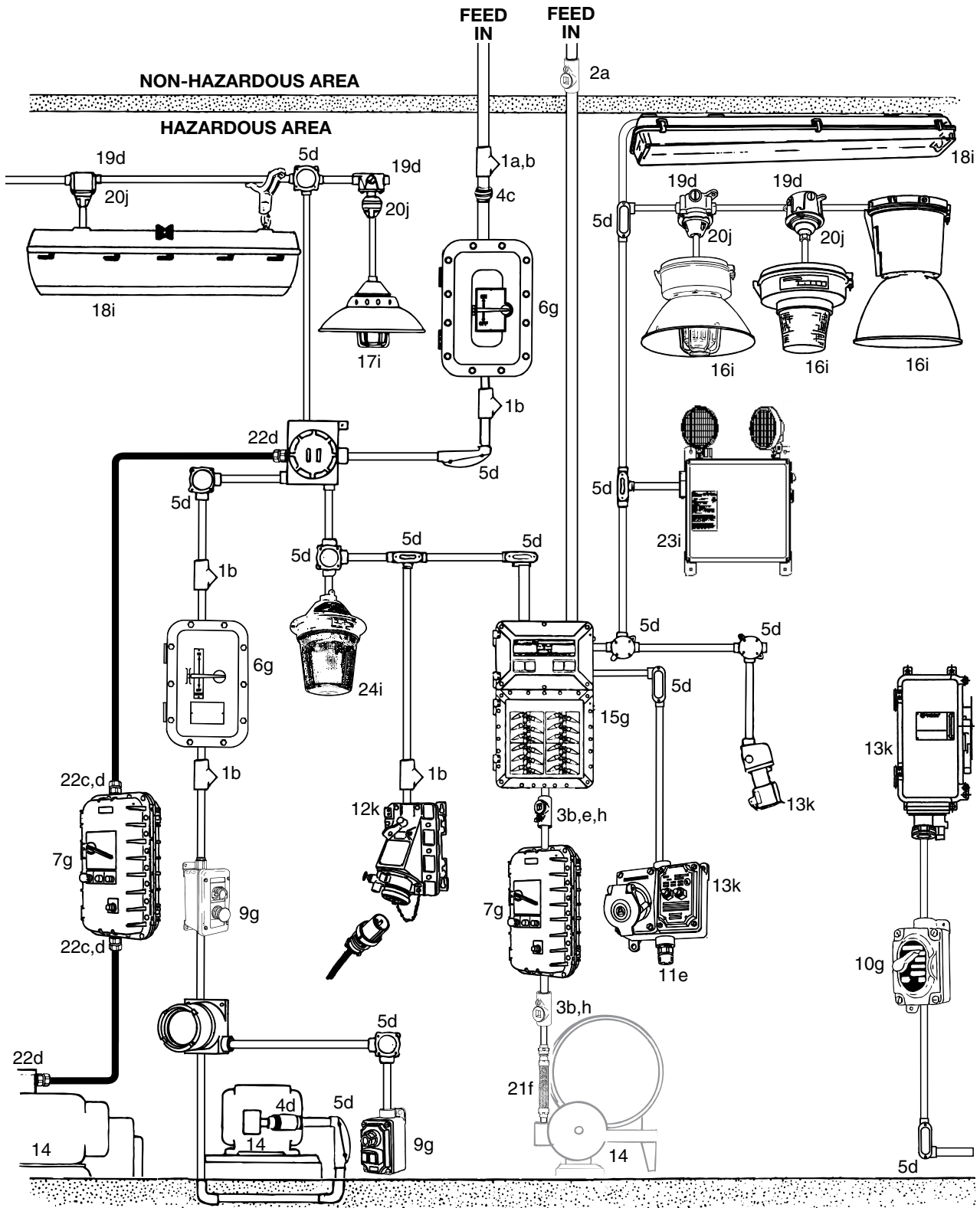

All items this page also suitable for Class I, Zone 2.

APPENDIX E-4: LIGHTING AND POWER DIAGRAM: CLASS I, DIVISION 2, GROUPS C, D; CLASS I, ZONE 2, GROUPS IIA, IIB

Key to Product

- 1— Sealing Fitting. EYSF/M, EYS 1, 2, 3, 16, 26, 36—used with vertical conduits.
- 2— Sealing Fittings. EYF/M, EYS, EYD, EYDM, ESUF/M—used with vertical or horizontal conduits.
- 3— Sealing Fitting, expanded fill. EYSEF, EYDEF.
- 4— Unions/Elbows. UNY-NR, UNF-NR, UNY/F, UNL, UNYL/ UNFL; ELF, ELME.
- 5— Conduit Boxes, Bodies, Fittings. Form 35, 85, 7, 8, 9, Mogul, JB, GSU, LBD, RS.
- 6— Circuit Breaker or Disconnect Switch. EB, AE, AEXMS, EDS, MD2DS.
- 7— Combination Circuit Breaker and Line Starter. AEB, bolted cover.
- 8— Combination Line Starter and Circuit Breaker, AE, threaded cover.
- 9— Push Button/Pilot Light, factory sealed. EDS, EFDB, UniCode.
- 10— Switch/Motor Starter, factory sealed. EFD, EFDB, EDS.
- 11— Drain/Breather, combination. ECDB5OHP.
- 12— Receptacle, non-factory sealed, interlocked, EBR, JBR.
- 13— Receptacle, factory sealed, U-Line. EFS with GFI, CES, CESD, MD2SR.
- 14— Motor for Division 2 Hazardous Location.
- 15— Lighting Panelboard, factory sealed. D2P.
- 16— Luminaires, HID—Mercmaster III, Mercmaster II, Mercmaster Low Profile, Areamaster I/2, Corrofflood.
- 17— Luminaires, Incandescent—Stylmaster, V-51.
- 18— Luminaires, Fluorescent—VRS, Mercmaster III Compact Fluorescent, FD Series, Stylmaster-PL, V-51-PL. FV Series.
- 19— Outlet Boxes for Pendant Mount Fixtures. JB, GSU.
- 20— Flexible Fixture Supports. AHG, EXJF, JB Cushion, AHG Cushion.
- 21— Flexible Connector. EXGJH, EXLK; Liquidtight flexible metal conduit and fittings. ST, STB, STN.
- 22— Cable/Connectors. MC-HL—listed for Division 2. TMCX.
- 23— Emergency Lighting System. N2LS.
- 24— Strobe Warning Light—Stylmaster Strobe.

National Electric Code® Reference

- a— *Sec. 501.15(B)(2)* Seals required on either side of the boundary (within 10 feet) entering or leaving the hazardous (classified) areas
- b— *Sec. 501.15(B)(1)* Seals required in all conduits connected to enclosures that are required to be explosionproof
- c— *Sec. 501.15(B)(1) and 501.15(E)(1)* Class I, Division 1 wiring methods such as threaded rigid metal conduit, IMC and explosionproof fittings are required between the seal and the explosionproof enclosure. MC-HL or MC cable is allowed however fittings must be Class I, Division 1 listed (cable connector with integral sealing method).
- d— *Sec. 501.10(B)* Boxes and fittings are not required to be explosionproof unless the enclosure contains arcing (contacts), sparking or heat producing devices. Permitted wiring methods include all those for Division 1 such as threaded RMC, threaded IMC and listed MC-HL cable with listed cable connectors. Also a variety of additional cable and raceway systems are permitted including MC cable with listed MC cable connectors.
- e— *Sec. 501.15(F)(1)* Drains/Breathers must be installed to prevent accumulation of liquids or condensed vapors.
- f— *Sec. 501.10(B)(2)* Flexible connections such as flexible fittings and liquidtight flexible metal conduit with listed fittings are permitted. Listed liquidtight flexible metal conduit fittings are fittings listed for use with liquidtight flexible metal conduit. They are not fittings listed for Class I, Division 2 hazardous (classified) locations. (There is no such thing as a liquidtight flexible metal conduit fitting listed for Class I, Division 2.)
- g— *Sec. 501.115(B)(1)* Circuit breakers, pushbuttons, switches, motor controllers shall be identified for the location - explosionproof or contacts are within a factory sealed explosionproof chamber.
- h— *Sec. 501.15(C)(6)* Approved expanded fill seals permit up to 40% fill of cross sectional area of conduit.
- i— *Sec. 501.130(B)(1)* Luminaires (lighting fixtures) shall be tested and marked with the operating temperature/T-Code (Class I, Division 2) or luminaires shall be identified Class I, Division 1 - explosionproof
- j— *Sec. 501.130(B)(3)* Pendant fixture stems must be threaded rigid metal or IMC conduit. Stems over 12 inches must be braced or have an approved flexible fitting/connector.
- k— *Sec. 501.145* Receptacles and plugs must be identified for the location (explosionproof or Class I, Division 2) and have a grounding conductor for portable equipment.

APPENDIX E-5: POWER DIAGRAM: CLASS II, DIVISIONS 1 AND 2, GROUPS E^o, F AND G; CLASS II, ZONES 21 AND 22[†]

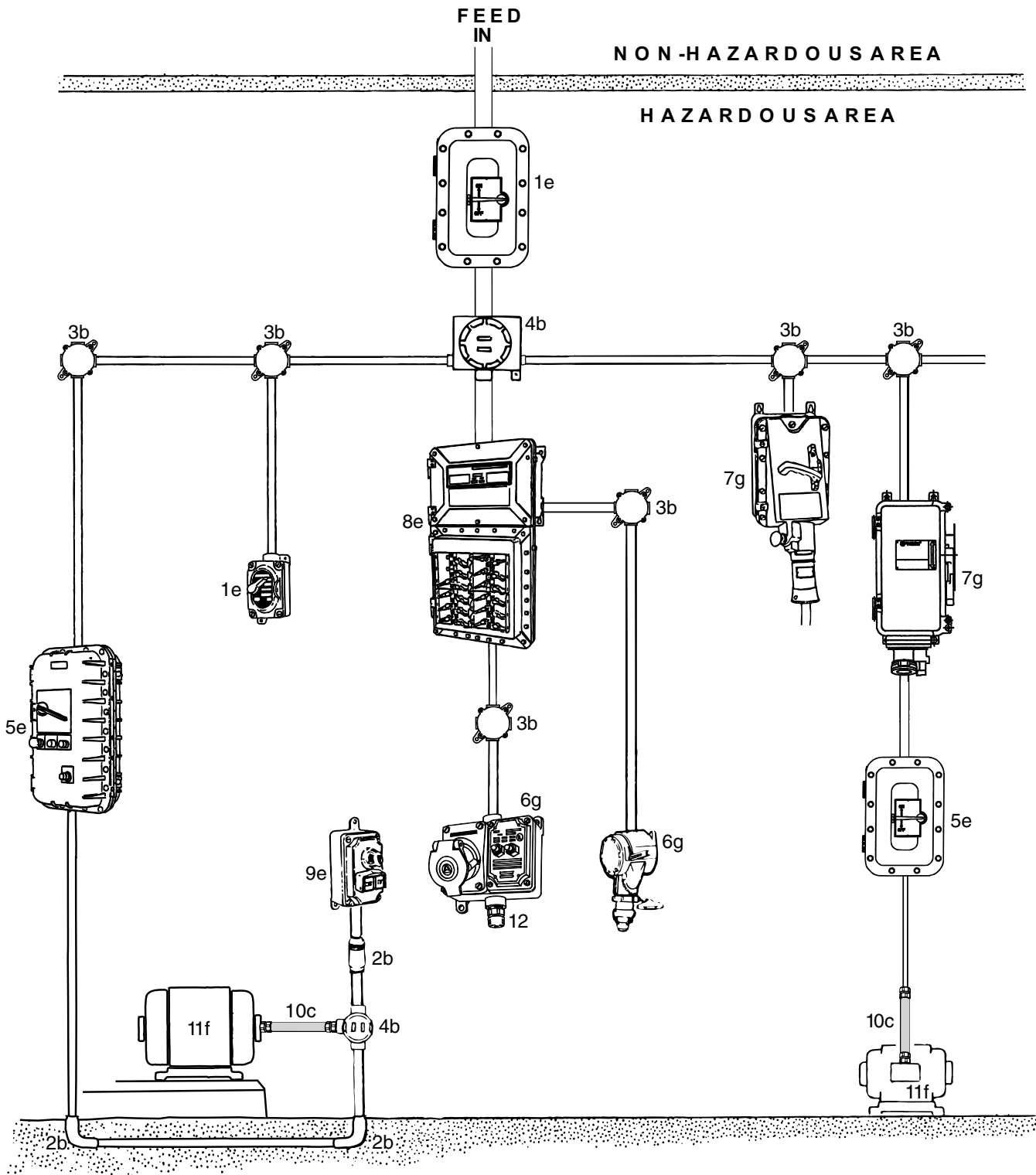

^o Where Class II, Group E dusts are present in hazardous quantities, there are only Division 1 locations.

APPENDIX E-5: POWER DIAGRAM: CLASS II, DIVISIONS 1 AND 2, GROUPS E[∅], F AND G; CLASS II, ZONES 21 AND 22[†]

Key to Product

- 1— Circuit Breaker or Disconnect Switch. AEB, EDS series
- 2— Unions/Elbows. UNY-NR, UNF-NR, UNY/F UNL, UNYL/UNFL; ELF, ELME.
- 3[†]— Junction Box. CPU, with ground surface cover.
- 4[†]— Junction Box. GUBB, with screw cover.
- 5— Combination/Motor Starter. AEB, AEXMS.
- 6— Receptacle. EFS U-Line with GFI, CPS, FSQC.
- 7— Receptacle, Interlocked. DBR, EBR, JBR, MD2SR.
- 8— Panelboard. EWP, D2P, ALPN, APPN, AGPN, APPF.
- 9— Push Button Station. EFDB, N2, EFS, EFD, UniCode,
- 10— Flexible Connector. Liquidtight, ST Fittings.
- 11— Motor for Location.
- 12—Combination Drain/Breather ECDB50HP.

National Electric Code® Reference

- a— *Sec. 502.10(A) and (B)* Wiring methods in Class, II Division 1 include threaded RMC, threaded IMC and MC-HL cable with cable connectors listed for Division 1. In addition to all the Division 1 wiring methods, permitted methods for Class II, Division 2 include unthreaded RMC & IMC as well as EMT. Also a variety of additional cable and raceway systems are permitted including MC cable with listed MC cable connectors.
- b— *Sec. 502.10(A)(1)(4) and (B)(4)* Boxes and fittings in Class II, Division 1 have threaded bosses and are dust Ignitionproof (NEMA 9) for Group E and when enclosures contain taps, splices or cable terminations. All other boxes and fittings in Class I, Division 1 and all boxes and fittings in Class II, Division 2 locations are dusttight. Where not available dusttight, use boxes and fittings approved for Class II, Division 1.
- c— *Sec. 502.10(A)(2) and (B)(2)* Flexible connections for Division 1 and Division 2 include dusttight flexible connectors, liquidtight flexible conduit (both metal and nonmetallic) with listed fittings, jacketed interlock armor MC cable with Class II, Division 1 listed connectors and flexible cord for extra hard usage with bushed fittings.
- d— *Sec. 502.15* Sealing is required to keep dust from entering a dust ignitionproof enclosure through the raceway and is the same for Division 1 and Division 2. It can be accomplished via distance or a “permanent and effective seal”. Sealing fittings must be accessible but not explosionproof.
- e— *Sec. 502.115(A) and (B)* Circuit breakers, pushbuttons, switches, motor controllers in Group E and Division 1 shall be dust ignitionproof. Dusttight enclosures are suitable for Division 2
- f— *Sec. 502.125* Motors and generators in Class II, Division 1 are identified for Class II, Division 1. For Division 2 see Table 500.8(D)(2)
- g— *Sec. 502.145(A) and (B)* In Division 1 receptacles and attachment plugs shall be identified for Class II. In Division 2 connection to the supply circuit cannot be made or broken while live parts are exposed. Identified Class II receptacles and attachment plugs will also meet this requirement. *Note:* Due to the conductive and abrasive nature of metal dusts, there are no plugs and receptacles made for use in a Group E location.

[∅] Where Class II, Group E dusts are present in hazardous quantities, there are only Division 1 locations.

[†] Products Listed for use in Class II, Division 1 and 2 are permitted to be installed in Class II, Zones 21 and 22 locations in accordance with the wiring methods in NEC® Article 506.

APPENDIX E-6: LIGHTING DIAGRAM: CLASS II, DIVISIONS 1, AND 2, GROUPS E^o, F, AND G; CLASS II, ZONES 21 AND 22[†]

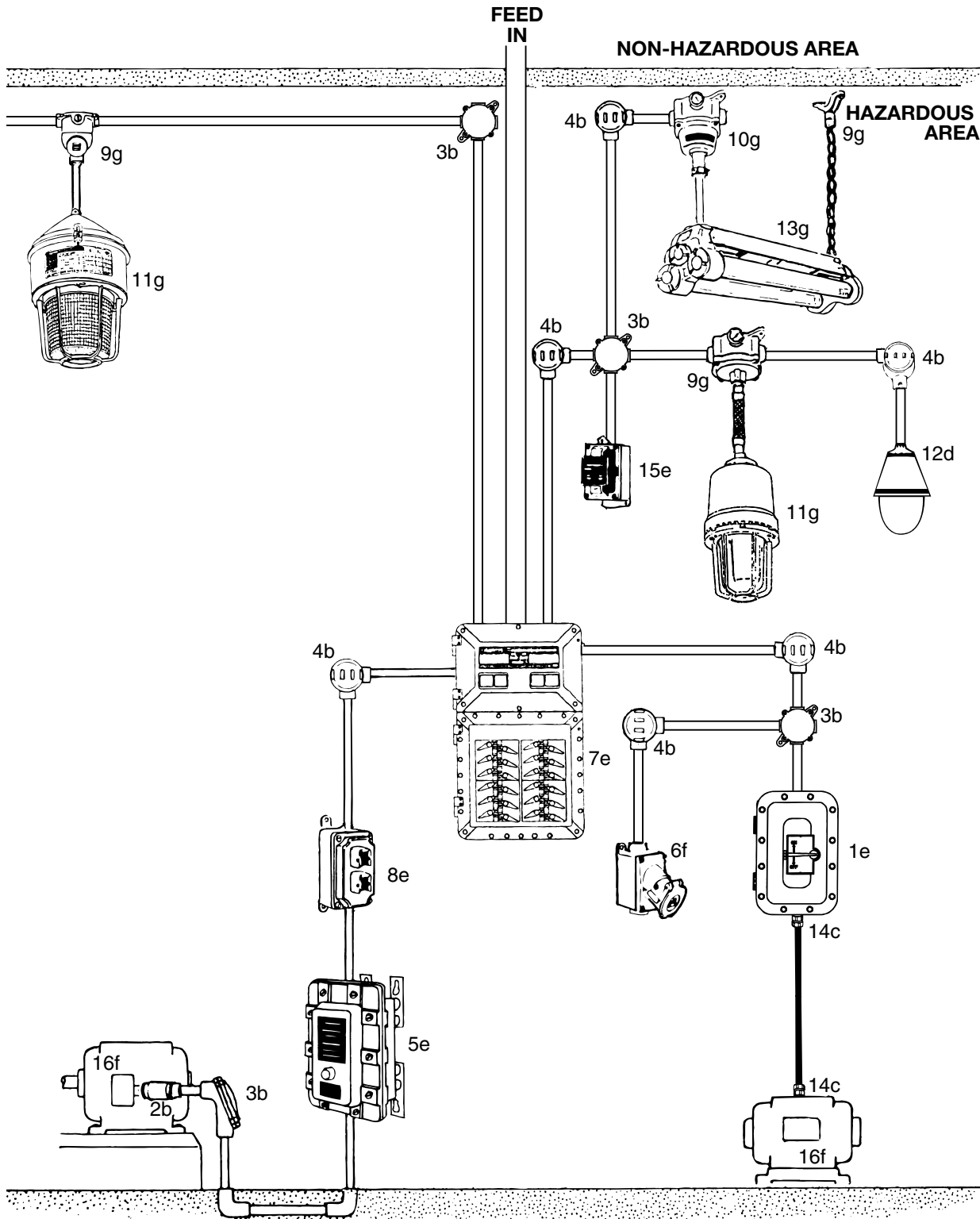

∅ Where Class II, Group E dusts are present in hazardous quantities, there are only Division 1 locations.

APPENDIX E-6: LIGHTING DIAGRAM: CLASS II, DIVISIONS 1, AND 2, GROUPS E[∅], F, AND G; CLASS II, ZONES 21 AND 22[†]

Key to Product

- 1— Circuit Breaker, Disconnect Switch, Manual Starter. EB,EDS, EXMS.
- 2— Unions/Elbows, UNY-NR, UNF-NR, UNY/F UNL, UNYL/UNFL, ELF, ELMF.
- 3[†]— Junction Box. CPU, ELBD, with ground surface cover.
- 4[†]— Junction Box. GR, with screw cover.
- 5— Manual Motor Starter. EXMS.
- 6— Receptacle. EFS U-Line.
- 7— Panelboard, EWP, D2P, ALPN, AGPN, APPN, APPF.
- 8— Push Button/Pilot Light, EFDB, N2, EFS, EFD, UniCode.
- 9— Fixture Hangers. Division 1—CPU, GRF, EFHC, EFHU, EXJF.
- 10— Fixture Hangers. Division 2—JB cushion, GS cushion, AHG cushion.
- 11— Luminaires, Division 1, HID—Codemaster, Codemaster Jr., Mercmaster III, Mercmaster II.
- 12— Luminaires, Division 1, Incandescent—A-51, EDTP, EHL.
- 13— Luminaires, Division 1, Fluorescent—EFU, MMIII Low Profile, APL, PAPL.
- 14— Flexible Connector. Liquidtight, ST Fittings.
- 15— Switches. EFS, EDS, Contender.
- 16— Motors for Location.

National Electric Code® Reference

- a— *Sec. 502.145(A) and (B)* In Division 1 receptacles and attachment plugs shall be identified for Class II. In Division 2 connection to the supply circuit cannot be made or broken while live parts are exposed. Identified Class II receptacles and attachment plugs will also meet this requirement. *Note:* Due to the conductive and abrasive nature of metal dusts, there are no plugs and receptacles made for use in a Group E location.
- b— *Sec. 502.10(A)(1)(4) and (B)(4)* Boxes and fittings in Class II Division 1 have threaded bosses and are dust Ignitionproof (NEMA 9) for Group E and when enclosures contain taps, splices or cable terminations. All other boxes and fittings in Class I, Division 1 and all boxes and fittings in Class II Division 2 locations are dusttight. Where not available dusttight, use boxes and fittings approved for Class II, Division 1.
- c— *Sec. 502.10(A)(2) and (B)(2)* Flexible connections for Division 1 and Division 2 include dusttight flexible connectors, liquidtight flexible conduit (both metal and nonmetallic) with listed fittings, jacketed interlock armor MC cable with Class II, Division 1 listed connectors and flexible cord for extra hard usage with bushed fittings.
- d— *Sec. 502.130(B)* In Division 2, luminaires must be suitable for Division 1 or be dusttight, temperature tested and marked with maximum lamp wattage not to exceed Table 500.8(D)(2).
- e— *Sec. 502.115(A) and (B)* Circuit breakers, pushbuttons, switches, motor controllers in Group E and Division 1 shall be dust ignitionproof. Dusttight enclosures are suitable for Division 2.
- f— *Sec. 502.125* Motors and generators in Class II, Division 1 are identified for Class II, Division 1. For Division 2 see Table 500.8(D)(2)
- g— *Sec. 502.130(A)* In Division 1, luminaires shall be identified for Class II (dust ignitionproof) and marked with maximum lamp wattage. Pendant luminaires are permitted to be suspended by threaded RMC or threaded IMC stems, or chain. Stems longer than 12 inches must be braced or have a Class II listed flexible fitting or connector. For wiring not enclosed in conduit, flexible cord for hard usage with seals shall be used.

[∅] Where Class II, Group E dusts are present in hazardous quantities, there are only Division 1 locations.

[†] Products Listed for use in Class II, Division 1 and 2 are permitted to be installed in Class II, Zones 21 and 22 locations in accordance with the wiring methods in NEC® Article 506.

APPENDIX E-7: LIGHTING AND POWER DIAGRAM: CLASS I, ZONE 1; CLASS I, ZONE 2

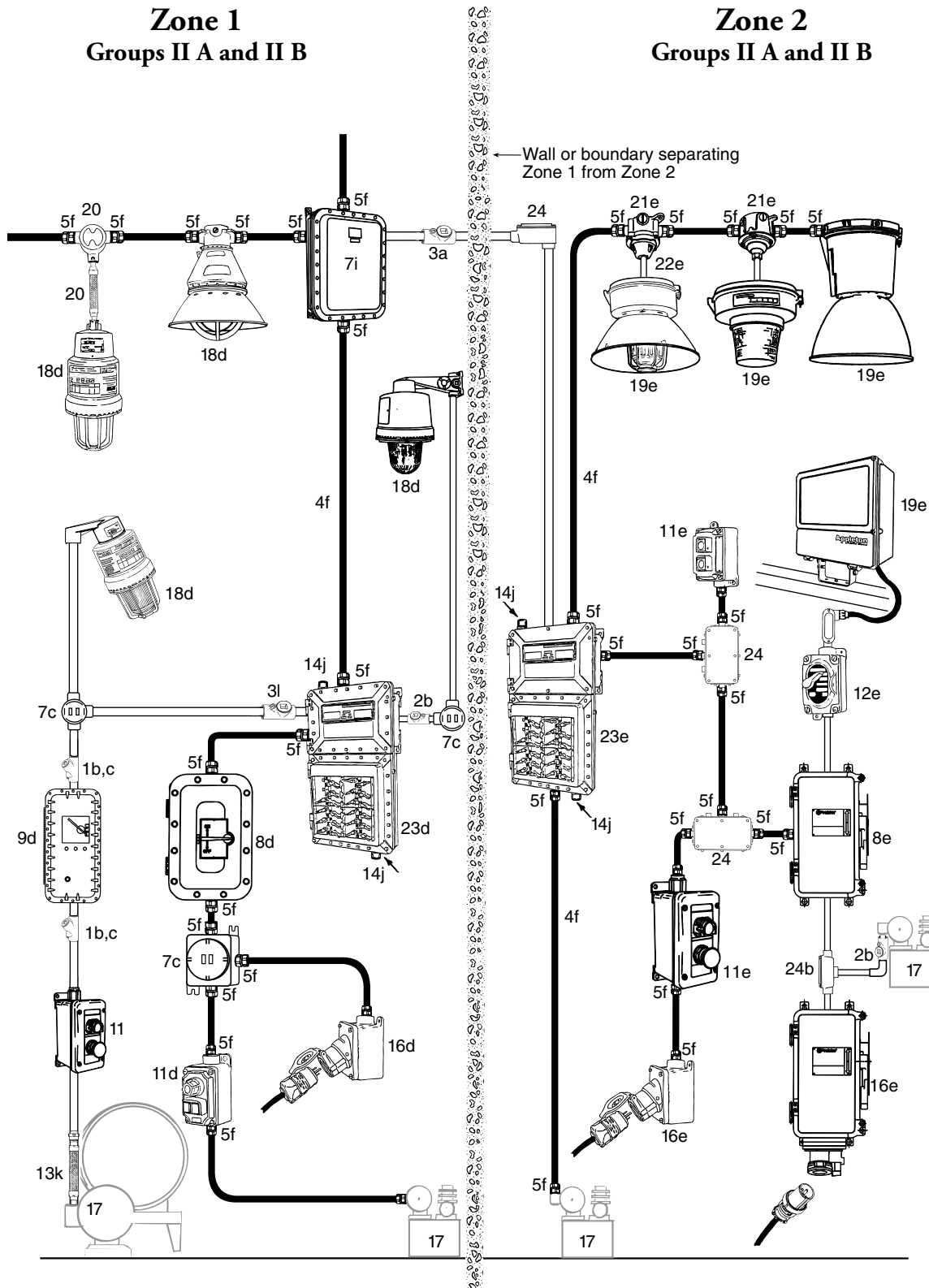

APPENDIX E-7: LIGHTING AND POWER DIAGRAM: CLASS I, ZONE 1; CLASS I, ZONE 2

Key to Product

- 1— Sealing Fittings. EYSF/M, EYS 1, 2, 3, 16, 26, 36—used with vertical conduits.
- 2— Sealing Fittings. EYF/M, EYS, EYD, EYDM, ESUF/M—used with vertical or horizontal conduits.
- 3— Sealing Fittings, expanded fill. EYSEF, EYDEF.
- 4— Cable, MC-HL, TMCX.
- 5— Cable connector, TMCX. See “f” opposite.
- 6— Unions. UNY-NR, UNF-NR, UNY/F UNL, UNYL/UNFL.
- 7— Explosionproof Junction Boxes. GR, GRSS, GRF, GUBB, GRU, GRUE, AJBEW.
- 8— Circuit Breaker or Disconnect Switch. AE, EB, AEXMS, EDS, MD2DS.
- 9— Combination Circuit Breaker and Line Starter. AEB, with bolted cover.
- 10— Push Button/Pilot Light, factory sealed. EDS, EFD.
- 11— Push Button/Pilot Light, factory sealed, approved for Zone 1 and Zone 2. UniCode, EDS, EFD, Division 2 Contender.
- 12— Switch/Motor Starter, factory sealed. EFD, EFD.
- 13— Flexible Coupling. EXGJH, EXLK.
- 14— Drain/Breather, combination. ECDB.
- 15— Receptacle, non-factory sealed, interlocked. EBR, JBR.
- 16— Receptacle, factory sealed. U-Line, EFS, MD2SR.
- 17— Motor for explosionproof location.
- 18— Luminaires, Zone 1. CodeMaster, CodeMaster Jr., A-51, EFU.
- 19— Luminaires, Zone 2. Mercmaster III, Mercmaster III-400, Mercmaster Low Profile, Areamaster.
- 20— Fixture Hangers, Zone 1. EXJF, EFHC, EFHU.
- 21— Fixture Hangers, Zone 2. JB, GSU.
- 22— Flexible Fixture Supports, Zone 2. JB Cushion, AHG Cushion.
- 23— Panelboard, Zone 1. EWP, ALPN, AGPN, APPN, APPF; Zone 2—D2P.
- 24— Conduit Boxes, Bodies, Fittings, Zone 2. Form 35, 85, 7, 8, Mogul, JB, GSU, LBD, RS.

National Electric Code® Reference

- a— *Sec. 505.16(B)(4)* Seals required within 3.05m (10 ft.) of either side of boundary entering or leaving hazardous area.
- b— *Sec. 505.15(B)* Wiring methods for Zone 1 sealing and drainage per *Sec. 505.16*. In Zone 2 [505.15(C)] wiring methods are same as for Division 2. Sealing and drainage per *Sec. 505.16*.
- c— *Sec. 505.15(B)* Listed explosionproof fittings and boxes used with rigid, steel IMC or MI cable required.
- d— *Sec. 505.20(B)* In Zone 1, equipment must be specifically listed and marked. Equipment listed for Class 1, Division 1 of the same gas group and with similar temperature marking (if any) is permitted.
- e— *Sec. 505.20(C)* In Zone 2, equipment suitable for Class 1, Division 1 or Division 2 of the same gas group and similar temperature is permitted.
- f— *Sec. 505.15(B)(C)* Approved MC-HL cable and listed fittings are suitable for use in Zone 1 and Zone 2.
- g— *Sec. 505.16(B)(2)*. Seals required within 18 inches of all arcing devices.
- i— *Sec. 505.9(E), 505.15(B) and 505.20(B)* Boxes must be explosionproof and have 5 full NPT threads engaged when used with rigid or IMC conduit. Approved MI cable and fittings allowed. Approved MC-HL cable allowed with approved cable connectors.
- j— *Sec. 505.16(E)* Drain/breathers must be installed to prevent accumulation of liquids or condensed vapors.
- k— *Sec. 505.15(B)(2)* Flexible connections as at motor terminals must be listed for Class I, Zone 1 or Division 1 location or can be flexible cord meeting 505.17.
- l— *Sec. 505.16(D)(5)* Approved expanded fill seals permit up to 40% fill of cross sectional area of conduit.

APPENDIX F: GLOSSARY OF DEFINITIONS

Aircraft Hanger:

- A location used for storage or servicing of aircraft in which gasoline, or other volatile flammable liquids or flammable gases or any jet fuels are used. It shall not include locations used exclusively for aircraft that have never contained such liquids or gases, or aircraft drained and properly purged (unfueled).

Approved:

- Acceptable to the authority having jurisdiction.

Associated Apparatus:

- Apparatus in which the circuits are not necessarily intrinsically safe themselves, but that affect the energy in the intrinsically safe circuits and are relied upon to maintain intrinsic safety. Associated apparatus may be either: (1) Electrical apparatus that has an alternative-type protection for use in the appropriate hazardous (classified) location, or (2) Electrical apparatus not so protected that shall not be used within a hazardous (classified) location.

Bulk Storage Plant:

- The portion of a property where flammable liquids are received by tank vessel, pipelines, tank car, or tank vehicle, and are stored or blended in bulk for the purpose of distributing such liquids by tank vessel, pipeline, tank car, tank vehicle, portable tank, or container.

Control Drawing:

- A drawing or other document provided by the manufacturer of the intrinsically safe or associated apparatus, or of the nonincendive field wiring apparatus or associated nonincendive field wiring apparatus, that details the allowed interconnections between the intrinsically safe and associated apparatus or between the nonincendive field wiring apparatus or associated nonincendive field wiring apparatus.

Dust-ignitionproof:

- Enclosed in a manner that will exclude dusts and, where installed and protected in accordance with this Code, will not permit arcs, sparks, or heat otherwise generated or liberated inside of the enclosure to cause ignition of exterior accumulations or atmospheric suspensions of a specified dust on or in the vicinity of the enclosure.

Dusttight:

- Constructed so that dust will not enter the enclosing case under specified test conditions.

Explosionproof Apparatus:

- Apparatus enclosed in a case that is capable of withstanding an explosion of a specified gas or vapor that may occur within it and of preventing the ignition of a specified gas or vapor surrounding the enclosure by sparks, flashes, or explosion of the gas or vapor within, and that operates at such an external temperature that a surrounding flammable atmosphere will not be ignited thereby.

Identified (as applied to equipment):

- Recognizable as suitable for the specific purpose, function, use, environment, application, and so forth, where described in a particular Code requirement.

Intrinsically Safe Apparatus:

- Apparatus in which all the circuits are intrinsically safe.

Intrinsically Safe Circuit:

- A circuit in which any spark or thermal effect is incapable of causing ignition of a mixture of flammable or combustible material in air under prescribed test conditions.

Intrinsically Safe Circuits, Different:

- Different intrinsically safe circuits are intrinsically safe circuits in which the possible interconnections have not been evaluated and approved as intrinsically safe.

Intrinsically Safe System:

- An assembly of interconnected intrinsically safe apparatus, associated apparatus, and interconnecting cables in that those parts of the system that may be used in hazardous (classified) locations are intrinsically safe circuits.

Listed:

- Equipment or materials included in a list published by an organization acceptable to the authority having jurisdiction and concerned with product evaluation, that maintains periodic inspection of production of listed equipment or materials, and whose listing states either that the equipment or material meets appropriate designated standards or has been tested and found suitable for a specified purpose.
- Note: Some Section in Chapter 5 of the *NEC*® use the term “listed” and others use the phrase “listed for the location” or “listed for the application”. In the case of “listed for the location” and “listed for the application” these phrases are synonymous. These mean that the equipment must be listed and specifically rated for use for the location (application).

Motor Fuel Dispensing Facility:

- A location where gasoline or other volatile flammable liquids or liquefied flammable gases are transferred to the fuel tanks (including auxiliary fuel tanks) of self-propelled vehicles or approved containers.

Nonincendive Circuit:

- A circuit in which any arc or thermal effect produced, under intended operating conditions of the equipment or due to opening, shorting, or grounding of field wiring, is not capable, under specified test conditions, of igniting the flammable gas, vapor, or dust-air mixture.

Qualified Person:

- One familiar with the construction and operation of the equipment and the hazards involved.

Simple Apparatus:

- A device that will neither generate nor store more than 1.2 volts, 0.1 ampere, 25 milliwatts, or 20 microjoules.

Special Permission:

- The written consent of the authority having jurisdiction.

Unclassified Location:

- Takes the place of undefined terms such as nonclassified and nonhazardous locations.

Volatile Flammable Liquid:

- A flammable liquid having a flash point below 38 °C (100 °F), or a flammable liquid whose temperature is above its flash point, or a Class II combustible liquid having a vapor pressure not exceeding 40 psia (276 kPa) at 38 °C (100 °F) whose temperature is above its flash point.

Appleton is our premium line of industrial electrical products under Appleton Group, a business unit of Emerson Industrial Automation.

Emerson Industrial Automation brings integrated manufacturing solutions to diverse industries worldwide. Our comprehensive product line, extensive experience, world-class engineering and global presence enable us to implement solutions that give our customers the competitive edge.

For over 150 years, our electrical product brands have been providing a rich tradition of long-term, practical, high quality solutions with applications ranging from the construction and safe operation of petrochemical and process plants to providing quality power that precisely controls automotive robotic production.

Engineers, distributors, contractors, electricians and site maintenance professionals around the world trust Emerson Industrial Automation brands to make electrical installations safer, more productive and more reliable.

Appleton Group is organized into three focused businesses that provide distributors and end-users expert knowledge and excellent service.

Electrical Construction Materials

This group is made up of the Appleton, Nutsteel and O-Z/Gedney brands. They manufacture a broad range of electrical products including conduit and cable fittings, plugs and receptacles, enclosures and controls, conduit bodies and industrial and hazardous lighting. Whether the application is hazardous location, industrial or commercial, the electrical construction materials group has the products to meet your needs.

Power Quality Solutions

The SolaHD brand offers the broadest power quality line, including uninterruptible power supplies, power conditioners, voltage regulators, shielded transformers, surge protection devices and power supplies.

Heating Cable Systems

This group is made up of the EasyHeat and Nelson brands. They offer a broad range of electrical heating cable products for residential, commercial and industrial applications.

Asia/Pacific
+ 65.6891.7600

Australia
+ 61.3.9721.0348

Brazil — São Paulo/SP
+ 55.11.2122.5777

Brazil — Camaçari/BA
+ 55.71.3496.4427

Canada
+ 1.888.765.2226

China
+ 86.21.3418.3888

Europe
+ 33.3.2254.1390

Mexico/Latin America
+ 52.55.5809.5049

Middle East/Africa/India
+ 971.4.811.8100

United States
+ 1.800.621.1506

Appleton Grp LLC
9377 W. Higgins Road
Rosemont, IL 60018
1.800.621.1506
appletonelec.com

Connect with Appleton
Facebook | Twitter | YouTube



Appleton Grp LLC d/b/a Appleton Group. The Appleton, O-Z/Gedney, SolaHD, EasyHeat, Nelson and Emerson logos are registered in the U.S. Patent and Trademark Office. EasyHeat, Inc. is a wholly owned subsidiary of Appleton Grp LLC. All other product or service names are the property of their registered owners. © 2014, Appleton Grp LLC. All rights reserved. The Emerson logo is a trademark and a service mark of Emerson Electric Co. ©2014 Emerson Electric Co.

EMERSON. CONSIDER IT SOLVED