

Fisher™ 1051 and 1052 Style H and J Sizes 40, 60 and 70 Rotary Actuators

Contents

Introduction	1
Scope of Manual	1
Description	2
Specifications	3
Educational Services	3
Principle of Operation	4
Installation	4
Actuator Mounting	5
Loading Connections	12
Adjustment	13
1051 and 1052 Turnbuckle Adjustment	13
1052 Spring Adjustment	14
Initial Compression	14
Stroking Range	15
Maintenance	15
Disassembly	16
Assembly	18
Changing Actuator Mounting	22
Changing Styles	22
Changing Positions	23
Top-Mounted Handwheels and Adjustable Travel Stops	25
Handwheel and Travel Stop Operations	25
Handwheel and Travel Stop Maintenance	26
For Top-Mounted Handwheels and Adjustable Up Travel Stops	27
For Adjustable Down Travel Stops	27

Figure 1. Fisher 1051 Actuator with H Mounting Adaptation and 3610J Positioner

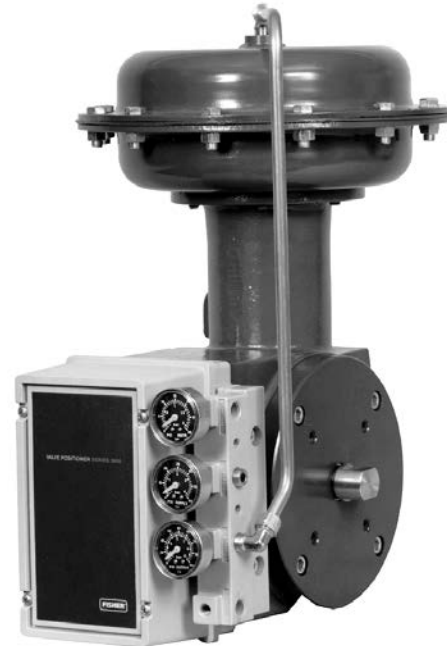

W4252

Parts Ordering	28
Parts List	28

Introduction

Scope of Manual

This manual provides installation, adjustment, operation, maintenance, and parts ordering information for Fisher 1051 (sizes 40 and 60) and 1052 (sizes 40, 60, and 70) diaphragm rotary actuators with H and J mounting adaptations (see figures 1 and 2). Also, this instruction manual provides information for the optional top-mounted handwheel, and both the optional up and down travel stops. Instructions for the control valve body, the positioner, accessories, and other sizes or constructions of this actuator are covered in separate manuals.

Table 1. Fisher 1051 and 1052 Actuator Specifications

<p>Operation</p> <p>Direct Acting: Increasing loading pressure extends the diaphragm rod out of the spring barrel</p> <p>Service:</p> <p>1051: For on-off or throttling service with positioner</p> <p>1052: For on-off or throttling service with or without a positioner</p> <p>Actuator Sizes</p> <p>1051: 40, and 60</p> <p>1052: 40, 60, and 70</p> <p>Maximum Diaphragm Sizing Pressure⁽²⁾⁽³⁾</p> <p>Size 40: 4.5 bar (65 psig)</p> <p>Size 60: 2.8 bar (40 psig)</p> <p>Size 70: 3.8 bar (55 psig)</p> <p>Maximum Diaphragm Casing Pressure⁽²⁾⁽³⁾</p> <p>Size 40: 5.2 bar (75 psig)</p> <p>Size 60: 3.4 bar (50 psig)</p> <p>Size 70: 4.5 bar (65 psig)</p> <p>Maximum Valve Shaft Rotation</p> <p>90, 75, or 60 deg with optional stops</p> <p>Torque Limits (mm)⁽⁴⁾</p> <p>Limited by maximum diaphragm sizing pressure or tables 2 and 3, whichever is less</p>	<p>Stroking Time</p> <p>Dependent on actuator size, rotation, spring rate, initial spring compression, and supply pressure. If stroking time is critical, consult your Emerson sales office</p> <p>Material Temperature Capabilities⁽³⁾</p> <p>Nitrile Diaphragm or O-Rings⁽¹⁾: -40 to 82°C (-40 to 180°F)</p> <p>Silicone Diaphragm: -40 to 149°C (-40 to 300°F)</p> <p>Travel Indication</p> <p>Graduated disk and pointer combination located on actuator end of valve shaft</p> <p>Pressure Connections</p> <p>1/4 NPT internal</p> <p>Mounting Positions</p> <p>See figure 10</p> <p>Approximate Weights</p> <p>See table 8</p> <p>Additional Specifications</p> <p>For casing pressure ranges and for material identification of the parts, see the Parts List</p>
<p>1. Nitrile O-rings are used in optional top-mounted handwheel, adjustable down travel stop, and adjustable up travel stop assemblies.</p> <p>2. Use this value to determine the maximum torque output allowed.</p> <p>3. The pressure / temperature limits in this manual and any applicable standard or code limitation for valve should not be exceeded.</p> <p>4. Exceeding any torque requirements could damage the actuator and impair safe operation.</p>	

Do not install, operate, or maintain a 1051 or 1052 actuator without being fully trained and qualified in valve, actuator, and accessory installation, operation, and maintenance. To avoid personal injury or property damage, it is important to carefully read, understand, and follow all the contents of this manual, including all safety cautions and warnings. If you have any questions about these instructions, contact your [Emerson sales office](#) before proceeding.

Description

1051 and 1052 diaphragm rotary actuators are pneumatic spring-return actuators for use with rotary-control valves and other equipment. The 1051 actuator can be used for on-off service, or it can be used for throttling service when equipped with a valve positioner. The 1052 actuator can be used for on-off service, or it can be used for throttling service when equipped with or without a valve positioner. The 1052 actuator spring is adjustable.

The H mounting adaptation permits the actuator to be used with equipment other than Fisher valve bodies. The mounting brackets and couplings for rotary actuation are user-provided. This mounting adaptation includes a flat-surface mounting plate that is drilled and tapped for attaching the user-provided bracket. Cap screws for attaching the bracket are provided. H mounting also includes an output shaft (with milled flats) to provide the Double D rotary output either directly or through a user-provided coupling. Output shaft diameters and torque limits are listed in table 2. Dimensional information for the mounting plate and output shaft are shown in figures 4, 5, and 6.

Figure 2. Fisher 1052 Actuator with J Mounting Adaptation



W4139-1

The **J mounting adaptation** permits the actuator to be used for rotary actuation of Fisher keyed-shaft butterfly valve bodies and other keyed-shaft equipment. This mounting adaptation uses the standard butterfly valve mounting bracket and provides an output shaft with an attached coupling for keyed equipment shafts. Coupling sizes and torque limits are listed in table 3. Dimensional information for the mounting bracket and stub shaft coupling is shown in figures 4, 5, and 7.

Additionally, a top-mounted handwheel can be applied for infrequent service as a manual handwheel actuator. For more frequent manual operation, a side-mounted handwheel actuator is available. Also, an adjustable up travel stop can be added to limit the actuator stroke in the upward direction, or an adjustable down travel stop can be added to limit actuator stroke in the downward direction.

Specifications

Specifications are shown in table 1 for 1051 and 1052 actuators. Specifications for a given 1051 or 1052 actuator as it originally comes from the factory are stamped on a nameplate attached to the actuator.

Educational Services

For information on available courses for 1051 and 1052 Style H and J actuators, as well as a variety of other products, contact:

Emerson Automation Solutions
Educational Services - Registration
Phone: 1-641-754-3771 or 1-800-338-8158
E-mail: education@emerson.com
emerson.com/fishervalvetraining

Table 2. Output Shaft Diameters and Torque Limits for Actuators With H Mounting

ACTUATOR SIZE	OUTPUT SHAFT DIAMETER		TORQUE LIMIT FOR H MOUNTING	
	mm	Inches	N•m	Inch-Pounds
40	22.2	7/8	240	2120
	28.6	1-1/8	468	4140
	38.1	1-1/2	1110	9815
60	28.6	1-1/8	468	4140
	38.1	1-1/2	1210	10,680
70 ⁽¹⁾	38.1	1-1/2	1210	10,680

1. 1052 actuator only.

Table 3. Acceptable Shaft Diameters and Torque Limits for Actuators With J Mounting

ACTUATOR SIZE	COUPLING AVAILABILITY BY KEYED SHAFT DIAMETER		TORQUE LIMIT FOR J MOUNTING	
	mm	Inches	N•m	Inch-Pounds
40	9.5	3/8	52	460
	12.7	1/2	69	610
	15.9	5/8	114	1010
	19.1	3/4	207	1830
	25.4	1	468	4140
60	19.1	3/4	207	1830
	25.4	1	468	4140
	31.8	1-1/4	1030	9110
	38.1	1-1/2	1360	12,000
70 ⁽¹⁾	50.8	2	2650	23,430
	31.8	1-1/4	1030	9110
	38.1	1-1/2	1360	12,000
	50.8	2 ⁽²⁾	2650	23,430

1. 1052 actuator only.

2. Coupling supplied for mating with either 44.5 or 50.8 mm (1-3/4 or 2-inch) keyed shaft.

Principle of Operation

The diaphragm rod moves down as loading pressure is increased on top of the diaphragm. As the loading pressure is decreased, the spring forces the diaphragm rod upward.

The spring and diaphragm have been selected to meet the requirements of the application and, in service, the actuator should produce full travel of the valve or other operated equipment with the diaphragm pressure as indicated on the nameplate.

Consult the separate positioner instruction manual for actuator principle of operation with positioner.

Installation

▲ WARNING

Always wear protective gloves, clothing, and eyewear when performing any maintenance operations to avoid personal injury.

To avoid personal injury or property damage caused by bursting of pressure retaining parts, be certain the service conditions do not exceed the limits given in table 1. Use pressure limiting or pressure relieving devices to prevent the diaphragm sizing pressure from exceeding the maximum allowable diaphragm sizing pressure.

Check with your process or safety engineer for any additional measures that must be taken to protect against process media.

If installing into an existing application, also refer to the WARNING at the beginning of the Maintenance section in this instruction manual.

⚠ WARNING

To avoid personal injury or parts damage, do not use an operating pressure that exceeds the Maximum Diaphragm Casing Pressure (table 1) or produces a torque greater than the Maximum Allowable Valve Shaft Torque (see Catalog 14). Use pressure-limiting or pressure-relieving devices to prevent the diaphragm casing pressure from exceeding its limit.

Figure 3. Top Mounted Handwheel

ACTUATOR SIZE	H _c		J _c	
	mm	Inch	mm	Inch
40	281	11.06	356	14.00
60	359	14.12	432	17.00
70 ⁽¹⁾	335	13.62	356	14.00

1. Size 70 available in 1052 only.

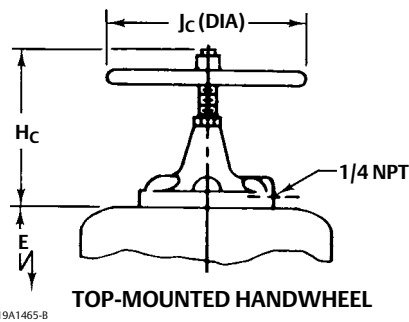

Actuator Mounting

Use the following steps to connect the actuator to a valve body or other equipment. Unless otherwise specified, key numbers are shown in figures 12 and 13. Mounting dimensions are shown in figures 4, 5, 6, and 7.

Note

For an actuator with an H mounting adaptation and a 22.2 through 38.1 mm (7/8 through 1-1/2 inch) output shaft, find dimensions and center of gravity information in figures 3, 4, 5, 6, and 9, and approximate weights in table 8. This information is required for proper fabrication of the user-provided bracket and coupling.

1. For an actuator with an H mounting adaptation, attach an appropriate mounting bracket (not provided) to the mounting plate (key 22) with the cap screws (key 78). See figures 4, 5, and 6 for mounting dimensions on the mounting plate. Tighten the cap screws to the bolt torques listed in table 4.
2. Consult figure 10 for available mounting styles and positions. The actuator is normally positioned vertically with the valve body or other equipment in a horizontal pipeline.

Note

If the milled flats or the coupling on the end of the actuator output shaft (key 87) are oriented such that the output shaft cannot accommodate the operated equipment shaft, refer to the Changing Positions portion of the Changing Actuator Mounting section. This procedure describes how the output shaft can be repositioned to accommodate the operated equipment shaft.

3. If using an actuator with a **J mounting** adaptation, note that the valve shaft coupling (key 90) is furnished with two keyways lettered A and B as shown in figure 8 and 12 (letters C and D on the coupling are not used and can be disregarded). Align the appropriate keyway with the keyway in the operated equipment shaft. If using a Fisher butterfly valve, align the appropriate keyway on the coupling with the valve shaft keyway indicated in table 9. Then install the woodruff key (key 91) in the shaft keyseat, and slide the coupling onto the shaft. It is helpful to apply a light coat of grease to the inside of the coupling before sliding it onto the shaft.
4. For an actuator with an **H mounting** adaptation, slide the actuator (with the user-provided mounting bracket attached) into the user-provided coupling on the operated shaft. Then, secure the actuator to the operated equipment in the desired mounting position with the appropriate fasteners, such as mounting cap screws. See figures 4, 5 and 6 for output shaft dimensions.
5. For an actuator with a **J mounting** adaptation, secure the mounting bracket (key 22) to the valve body with the cap screws (key 78, not shown). Tighten the cap screws to the bolt torques in table 4. For 31.8 and 38.1 mm (1-1/4 and 1-1/2 inch) valve shafts, also place the two spacers (key 92, not shown) between the mounting bracket and valve body during this step.
6. For an actuator with a **J mounting** adaptation and a **50.8 mm (2-inch) output shaft** (key 87, figure 14), note that the valve shaft coupling (key 90, figure 14) is furnished with two keyways lettered A and B as shown in figure 8 (letters C and D on the coupling are not used and can be disregarded). Align the appropriate keyway with the keyway in the operated equipment shaft. Then, install the woodruff key (key 91, not shown in figure 14) in the shaft keyseat, and slide the coupling onto the shaft using the appropriate coupling keyway (see table 9 and figure 8). It is helpful to apply a light coat of grease to the inside of the coupling before sliding it onto the shaft. Secure the actuator (user-provided mounting bracket) to the operated equipment in the desired mounting position with the appropriate fasteners, such as mounting cap screws.
7. Follow the instructions given in the Turnbuckle Adjustment section before proceeding to the Loading Connection portion of this section.

Table 4. Key 78 Cap Screw Torque Values

STYLE H MOUNTING						
Actuator Size	Valve Shaft Diameter		Bolt Size	Bolt Torque		Key 78 Part Number
	mm	Inch	Inch	N • m	lbf • ft	
40	22.2	7/8	5/16	22.6	16.7	1C5958X0042
40	28.6	1-1/8	3/8	39	29	1A353124052
60	28.6	1-1/8	3/8	39	29	1A353124052
40	38.1	1-1/2	1/2	92	68	1A582324052
60, 70	38.1	1-1/2	1/2	92	68	1A582324052
STYLE J MOUNTING - FLAT PLATE MOUNTING						
60, 70	44.5	1-3/4	1/2	92	68	1A582324052
60, 70	50.8	2	1/2	92	68	1A582324052
STYLE J MOUNTING - FISHER 7600, 9100, 9500 WITH KEYED SHAFT						
40	9.5	3/8	3/8	39	29	1A341824052
40	12.7	1/2	3/8	39	29	1A341824052
40	15.9	5/8	3/8	39	29	1A341824052
40	19.1	3/4	3/8	39	29	1A341824052
60	19.1	3/4	3/8	39	29	1A341824052
40	25.4	1	3/8	39	29	1A341824052
60	25.4	1	3/8	39	29	1A341824052
60, 70	31.8	1-1/4	5/8	163	120	1P1477X0012
60, 70	38.1	1-1/2	5/8	163	120	1P1477X0012

Table 5. Style H or J Mounting Dimensions

ACTUATOR SIZE	C	E		F	H	P	Y
		1051	1052				
mm							
40	333	505	607	54	114	175	73
60	473	749	876	64	121	186	76
70 ⁽¹⁾	536	---	849	64	121	186	76
Inch							
40	13.12	19.88	23.88	2.12	4.50	6.88	2.88
60	18.62	29.50	34.50	2.50	4.75	7.31	3.00
70 ⁽¹⁾	21.12	---	33.44	2.50	4.75	7.31	3.00

1. Size 70 available in 1052 only.

Figure 4. Fisher 1051 Mounting Dimensions (refer to table 5)

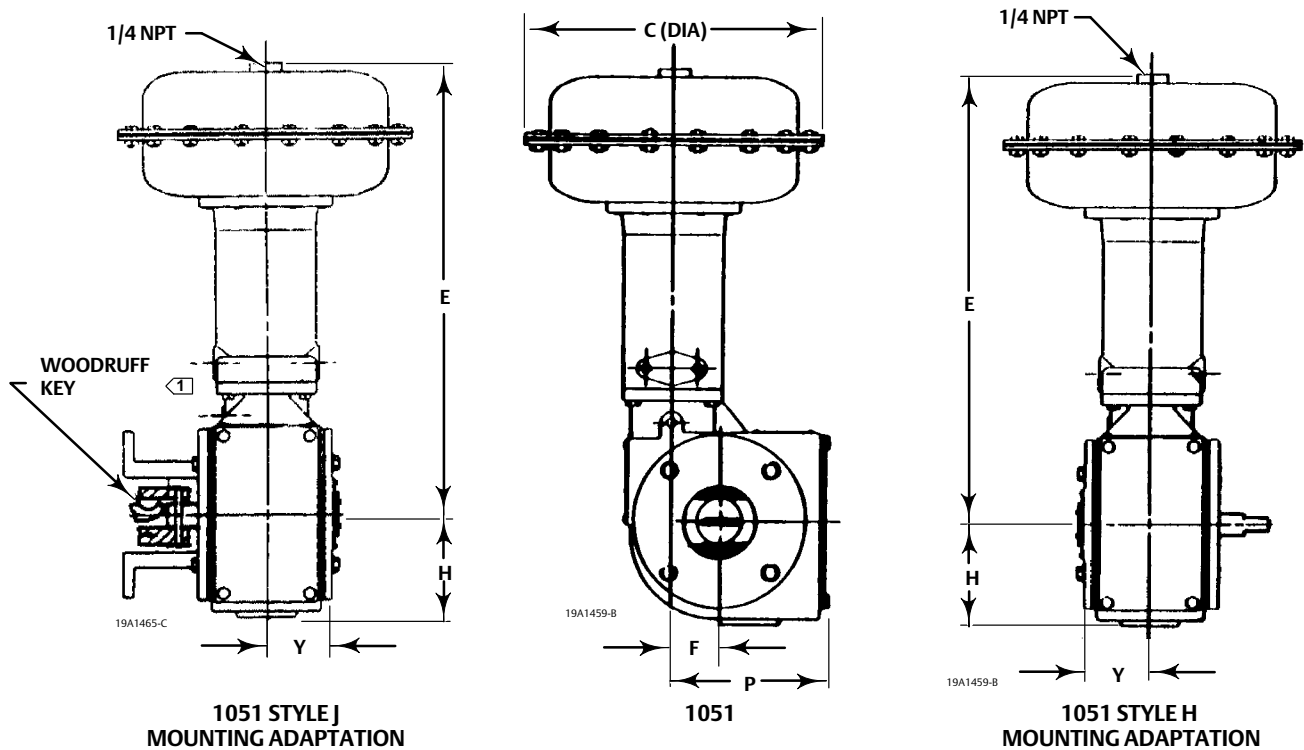

NOTE:
 1 SEE PARTS LIST FOR WOODRUFF KEY NUMBERS
 C0577-3

Figure 5. Fisher 1052 Mounting Dimensions (refer to table 5)

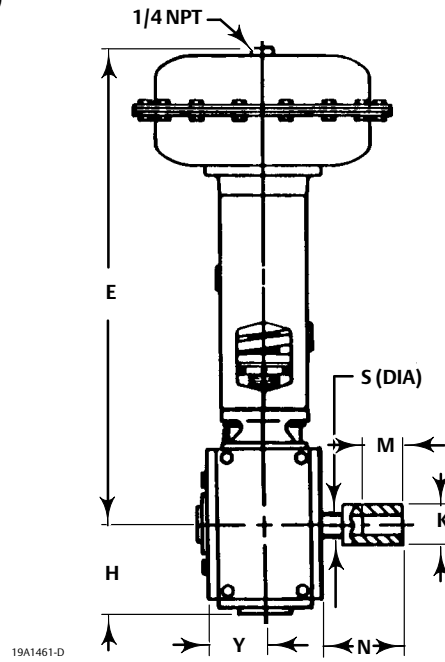
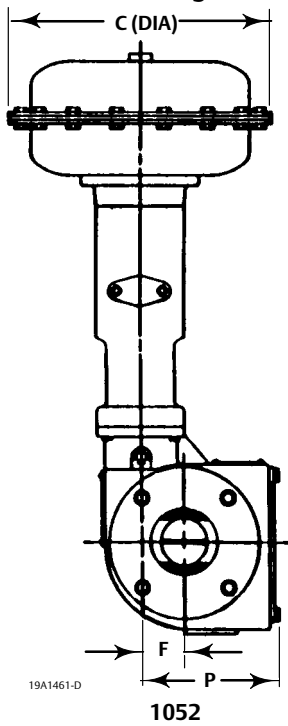

1052 STYLE J MOUNTING ADAPTATION
FOR 44.5 AND 50.8 mm (1-3/4 AND 2-INCH)
KEYED EQUIPMENT SHAFT

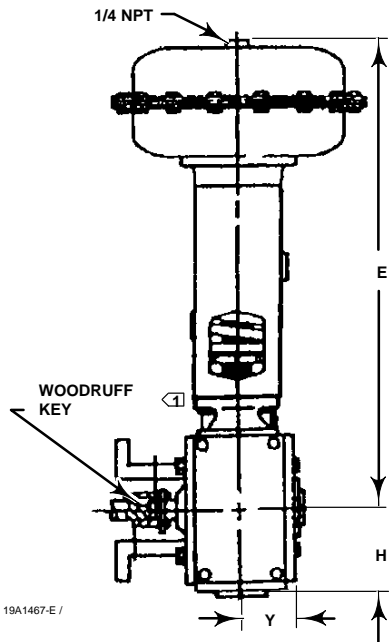

1052 STYLE J ADAPTATION
9.5 THRU 38.1 mm (3/8 THRU 1-1/2-INCH) OUTPUT SHAFTS

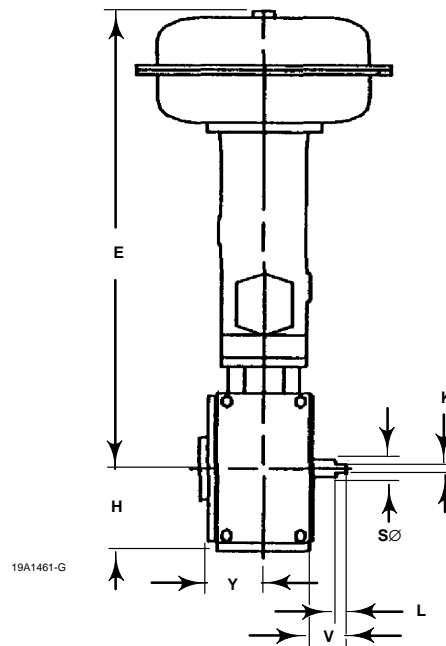

1052 STYLE H ADAPTATION
12.7 THRU 38.1 mm (1/2 THRU 1-1/2-INCH) OUTPUT SHAFTS

NOTE:

1 SEE PARTS LIST FOR WOODRUFF KEY NUMBERS

C0676-3

Table 6. Style H Mounting Dimensions

ACTUATOR SIZE 1051	ACTUATOR SIZE 1052	S ACTUATOR OUTPUT SHAFT DIAMETER		V		L		K ⁽¹⁾		T		U		W
		mm	Inch	mm	Inch	mm	Inch	mm	Inch	mm	Inch	mm	Inch	
40	40	22.2	7/8	26.2	1.03	19.1	0.75	<u>15.75</u> 15.62	<u>0.620</u> 0.615	57.2	2.25	28.4	1.12	5/16-18 UNC
40 & 60	40 & 60	28.6	1-1/8	26.2	1.03	19.1	0.75	<u>22.10</u> 21.97	<u>0.870</u> 0.865	76.2	3.00	38.1	1.50	3/8-16 UNC
	40, 60 & 70	38.1	1-1/2	28.4	1.50	28.4	1.12	<u>28.45</u> 28.32	<u>1.120</u> 1.115	88.9	3.50	44.5	1.75	1/2-13 UNC

1. Tolerance for the K dimension is indicated by showing maximum and minimum dimensions.

Figure 6. Fisher 1051 and 1052 Style H Mounting Dimensions (refer to table 6)

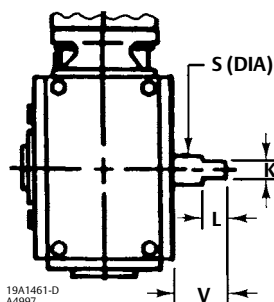

19A1461-D
A4997

22.2 THRU 38.1 mm
(7/8 THRU 1-1/2 INCH)
OUTPUT SHAFTS WITH
STYLE H MOUNTING

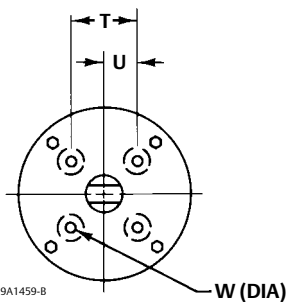

19A1459-B

22.2 THRU 38.1 mm
(7/8 THRU 1-1/2 INCH)
OUTPUT SHAFTS WITH
STYLE H MOUNTING

A3254-1

Table 7. Style J Mounting Dimensions

ACTUATOR SIZE 1051 & 1052	VALVE SHAFT DIAMETER		COUPLING ⁽¹⁾ INNER DIAMETER		V		L ⁽²⁾		K		T		U		W	
	mm	Inch	mm	Inch	mm	Inch	mm	Inch	mm	Inch	mm	Inch	mm	Inch	mm	Inch
40	9.5	3/8	<u>9.53</u> 9.58	<u>0.375</u> 0.377	137	5.38	39.6	1.56	15.7	0.62	117	4.62	---	---	11.2	0.44
	12.7	1/2	<u>12.70</u> 12.75	<u>0.500</u> 0.502	137	5.38	39.6	1.56	15.7	0.62	117	4.62	---	---	11.2	0.44
	15.9	5/8	<u>15.90</u> 15.95	<u>0.626</u> 0.628	160	6.31	49.3	1.94	25.4	1.00	146	5.75	31.8	1.25	11.2	0.44
40 & 60	19.1	3/4	<u>19.05</u> 19.10	<u>0.750</u> 0.752	160	6.31	47.8	1.88	20.6	0.81	146	5.75	31.8	1.25	11.2	0.44
	25.4	1	<u>25.43</u> 25.48	<u>1.0010</u> 1.0025	160	6.31	47.8	1.88	17.5	0.69	146	5.75	31.8	1.25	11.2	0.44
60 & 70 ⁽³⁾	31.8	1-1/4	<u>31.75</u> 31.80	<u>1.250</u> 1.252	148	5.81	68.3	2.69	30.2	1.19	210	8.25	50.8	2.00	17.5	0.69
	38.1	1-1/2	<u>38.13</u> 38.18	<u>1.501</u> 1.503	148	5.81	68.3	2.69	23.9	0.94	210	8.25	50.8	2.00	17.5	0.69
60 & 70 ⁽³⁾	44.5 & 50.8	1-3/4 & 2	<u>44.45</u> 44.50	<u>1.750</u> 1.752	123	4.84	69.9	2.75	---	---	88.9	3.50	44.5	1.75	1/2-13 UNC ⁽⁴⁾	1/2-13 UNC ⁽⁵⁾
	50.8	2	<u>50.83</u> 50.90	<u>2.001</u> 2.004	123	4.84	69.9	2.75	---	---	88.9	3.50	44.5	1.75	1/2-13 UNC ⁽⁴⁾	1/2-13 UNC ⁽⁵⁾

1. Tolerance for the Coupling Inner diameter is indicated by showing maximum and minimum dimensions.
 2. The L dimension is the matchline to the end of the actuator shaft.
 3. Size 70 is only available for the 1052.
 4. 25.4 mm deep.
 5. 1 inch deep.

Figure 7. Fisher 1051 and 1052 Style J Mounting Dimensions (refer to table 7)

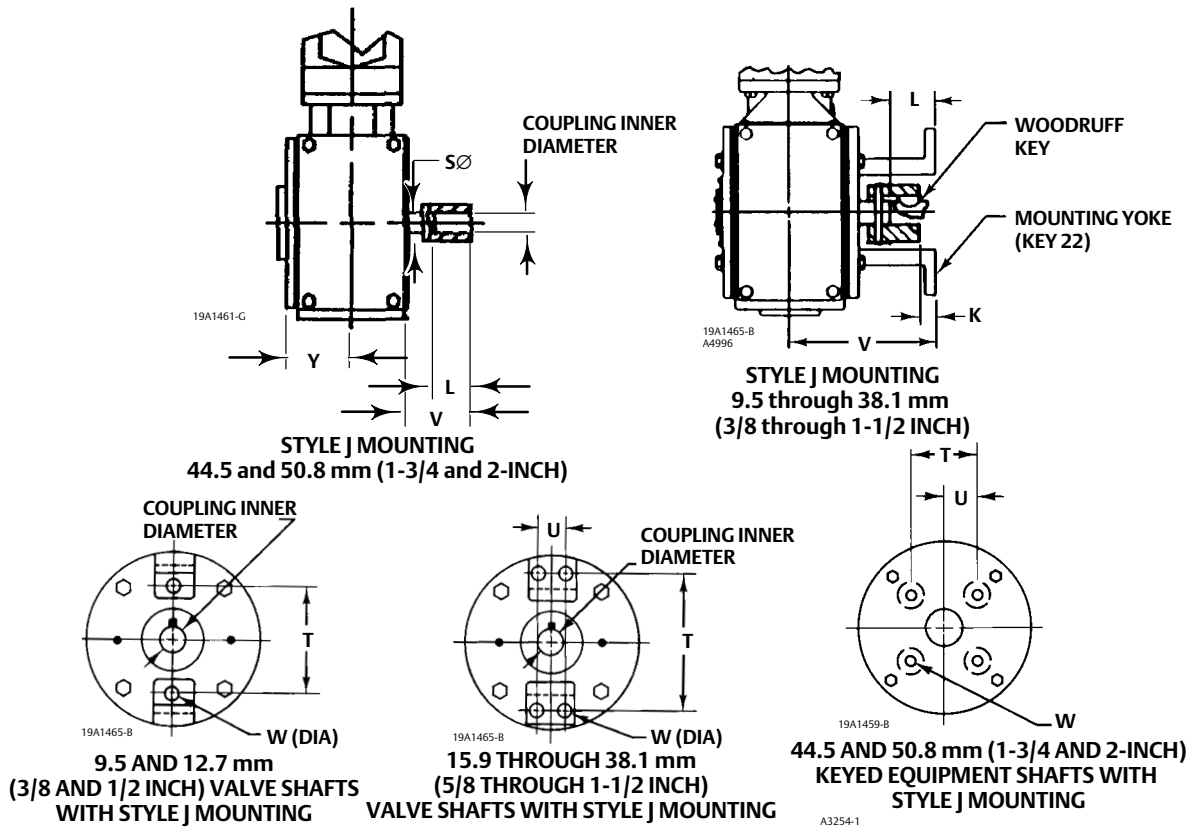

Table 8. Approximate Actuator Weights

SIZE	1051		1052		TOP-MOUNTED HANDWHEEL	
	Kg	Lb	Kg	Lb	Kg	Lb
40	43	94	45	99	7.3	16
60	89	197	92	203	11	24
70	---	---	123	272	21.3	47

Table 9. Keyway Alignment Information⁽¹⁾

DESIRED ACTUATOR ACTION	DESIRED SHAFT ROTATION, DEGREES	ACTUATOR MOUNTING POSITION	COUPLING KEYWAY TO USE ⁽³⁾	VALVE SHAFT KEYWAY TO USE FOR FISHTAIL™ DISK VALVE BODIES ⁽²⁾ (SEE FIGURE 10)			
				Clockwise to Close Valve Action ⁽⁴⁾		Counterclockwise to Close Valve Action ⁽⁴⁾	
				Flow Left to Right ⁽⁴⁾	Flow Right to Left ⁽⁴⁾	Flow Left to Right ⁽⁴⁾	Flow Right to Left ⁽⁴⁾
Push Down to Open (PDTO)	60 or 90	1	B	Nose	Tail	Tail	Nose
		2	A	Tail	Nose	Nose	Tail
		3	B	Tail	Nose	Nose	Tail
		4	A	Nose	Tail	Tail	Nose
Push Down to Close (PDTC)	60 ⁽⁵⁾ or 90	1	A	Tail	Nose	Tail	Nose
		2	B	Tail	Nose	Tail	Nose
		3	A	Nose	Tail	Nose	Tail
		4	B	Nose	Tail	Nose	Tail

1. For actuators with J mounting.
2. For conventional disk valve bodies, use either valve shaft keyway.
3. See figure 10 for reference coupling orientation to use with this table.
4. When viewed from actuator side of valve body.
5. For 60-degree rotation with PDTC action, the coupling and actuator output shaft assembly will be offset 30 degrees clockwise (for actuator housing construction style B) or counterclockwise (for actuator housing construction style A) in the lever when viewed from the splined end of the actuator shaft. 30 degrees is one spline tooth for 9.5, 12.7, and 15.9 mm (3/8, 1/2, and 5/8-inch) valve shafts and two spline teeth for 19.1 through 38.1 mm (3/4 through 1-1/2 inch) valve shafts.

Figure 8. Valve Shaft Coupling

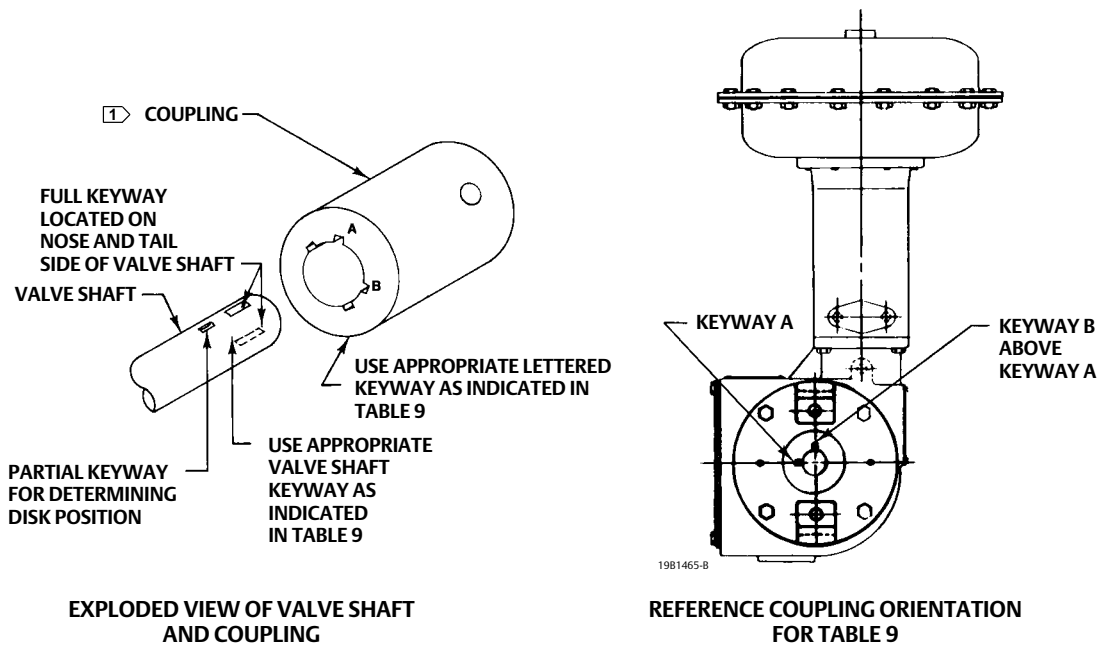

NOTE:
 1. FOR USE WITH J MOUNTING ADAPTATION (UP TO 50.8 mm (2-INCH) KEYED SHAFT DIAMETERS).
 A3253-1

Figure 9. Center of Gravity Dimensions

ACTUATOR TYPE	ACTUATOR SIZE	X		Y	
		mm	Inch	mm	Inch
1051	40	15	0.6	191	7.5
	60	10	0.4	361	14.2
1052	40	15	0.6	241	9.5
	60	10	0.4	432	17.0
	70	23	0.9	488	19.2

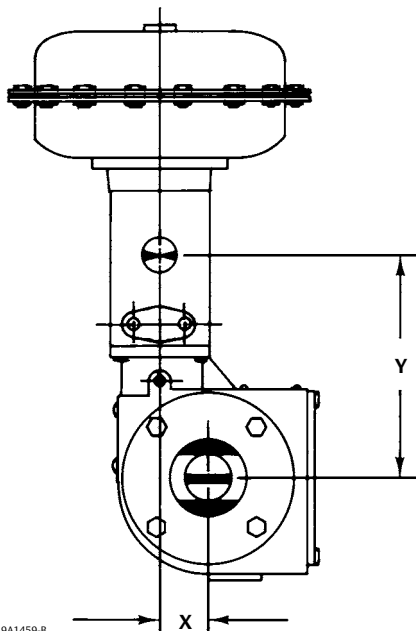

Loading Connection

1. Connect the loading pressure piping to the pressure connection in the top of the diaphragm casing.

For size 40 through 60 actuators, run either NPS 1/4 pipe or 3/8-inch tubing between the NPT 1/4 pressure connection and the positioner or automatic controller.

For size 70 actuators, run either pipe or tubing between the pressure connection and the positioner or automatic controller. If necessary, remove the 1/4-inch bushing in the pressure connection to increase connection size.

2. Keep the length of pipe or tubing as short as possible to avoid transmission lag in the control signal. If an accessory (such as a volume booster or a positioner) is used, be sure that the accessory is properly connected to the actuator. If a positioner is part of the assembly, the pressure connection to the actuator will normally be made at the factory.
3. When the actuator is completely installed and connected to the instrument, check for correct action (air-to-open or air-to-close) to match the controlling instrument. For successful operation, the actuator stem and operating shaft must move freely in response to the loading pressure change on the diaphragm.

Adjustment

⚠ WARNING

Before performing any adjustment steps, follow the steps in the WARNING at the beginning of the Maintenance section.

1051 and 1052 Turnbuckle Adjustment

Correct turnbuckle adjustment ensures that the valve body or other operated equipment is correctly closed when the actuator is against its travel stops. The turnbuckle adjustment is the only adjustment necessary on the 1051 actuator. Key numbers used in this procedure are shown in figure 12 for 1051 actuators and in figure 13 for 1052 actuators.

For accurate adjustment, remove the valve body or other operated equipment from the pipeline.

A regulated air supply will be required to stroke the actuator. Consult table 10 for the sizes of the three open end wrenches required for this procedure.

1. Remove the access plate (key 59). Also remove the machine screws (key 60), if present.

Note

For the most accurate adjustment of the actuator, do not remove the cover (key 33) during this procedure.

2. Loosen the lower locknut (key 16).

Table 10. Wrench Sizes Required for Turnbuckle Adjustment, Inches

Actuator	Size	Turnbuckle (Key 57)	Lower Locknut (Key 16)	Upper Locknut (Key 58)
1051 & 1052	40	1-1/8	3/4	1-1/8
	60	1-5/16	15/16	1-5/16
1052	70	1-5/16	1-1/8	1-5/16

3. Make sure the actuator housing (key 20) is clear of any tools or other instruments that could obstruct the actuator stroke path. Pressure the diaphragm casing enough to stroke the actuator down so that the left-hand threaded upper locknut (key 58) is accessible through the access opening. Loosen the locknut.
4. Use one of the following:
 - a. For push-down-to-close action—Slowly stroke the actuator to the down travel stop. Consult the appropriate instruction manual for determining the closed position of the valve body or other operated equipment. Adjust the turnbuckle (key 57) until the closed position is reached. Lock this adjustment with the left-hand threaded locknut (key 58). Stroke the actuator to the mid-travel position, and tighten the locknut (key 16). Tighten each locknut to the appropriate torque value listed in table 11.

⚠ WARNING

Exceeding any torque requirements could damage the actuator and impair safe operation.

- b. For push-down-to-open action—Consult the appropriate instruction manual for determining the closed position of the valve or other operated equipment. Release all pressure from the diaphragm casing, making sure the

diaphragm is against its up travel stop. Be sure that the optional handwheel is adjusted to its topmost position so that the closed position of the actuator and valve body or other operated equipment can be reached simultaneously. Check the position of the valve body or other operated equipment with respect to its properly closed position. Stroke the actuator so the turnbuckle (key 57) is accessible through the access opening. Adjust the linkage. Release pressure to the actuator, and check the new adjustment. Continue this procedure until the operated equipment is in the closed position when the actuator is resting on its up travel stop. Tighten locknut (key 16). Stroke the actuator, and tighten the left-hand threaded locknut (key 58). Tighten each locknut to the appropriate torque value listed in table 11.

⚠ WARNING

Exceeding any torque requirements could damage the actuator and impair safe operation.

5. Replace the access plate (key 59). Also, replace the machine screws (key 60), if present.
6. Loosen the self-tapping screws (key 38), and adjust the travel indicator (key 37). Retighten the self-tapping screws.

1052 Spring Adjustment

Initial Compression

The 1052 nameplate specifies a spring set, which is the initial compression adjusted into the actuator spring. Initial compression is the casing pressure at which the diaphragm and diaphragm rod begin to move away from the up travel stop with the actuator disconnected from the valve body or other operated equipment. (With the actuator connected and pressure applied to the valve body or other operated equipment, a higher casing pressure will be required to start actuator travel). The initial compression was selected (based upon the service conditions specified when the actuator was ordered) so that when the actuator and valve body or other operated equipment are in service, the operated equipment will close properly and full travel will be obtained within a diaphragm casing pressure range of 0 to 1.2, 0 to 2.3, 0 to 2.8 or 0 to 3.8 bar (0 to 18, 0 to 33, 0 to 40, or 0 to 55 psig) depending on specific actuator size and construction.

If the actuator has been disassembled or if the spring adjustment was changed, and it is desired to match the initial compression stated on the nameplate, make sure the rod end bearing (key 17, figure 13) has been disconnected from the lever (key 27, figure 13). Adjust the spring so that the diaphragm rod just starts to travel at the spring set pressure specified on the nameplate. Be sure the rod end bearing does not hit the lever as the diaphragm and diaphragm rod move away from the up travel stop.

To adjust the spring, insert a round rod into one of the slots in the lower bearing seat (key 73, figure 13). Slot diameter is 9.5 mm (3/8-inch) for size 40 actuators, 15.9 mm (5/8-inch) for size 60 actuators, and 19.1 mm (3/4-inch) for size 70 actuators.

Rotate the bearing seat to move it toward the casings (keys 1 and 2, figure 13) to increase initial compression or away from the casings to decrease initial compression.

Table 11. Recommended Bolting Torques⁽¹⁾

KEY NUMBER	ACTUATOR SIZE					
	40		60		70	
	Nom	lb•ft	Nom	lb•ft	Nom	lb•ft
6	27	20	27	20	27	20
7 & 8	41	30	41	30	102	75
9	34	25	102	75	102	75
16	34	25	61	45	102	75
18	81	60	163	120	271	200
21	23	17	68	50	68	50
23	34	25	81	60	81	60
28	81	60	163	120	271	200
34	34	25	81	60	81	60
40	9	7	9	7	9	7
54 handwheel	34	25	34	25	34	25
54 down stop	27	20	66	49	69	51
58	102	75	163	120	163	120
141	41	30	41	30	81	60

1. Exceeding any torque requirements could damage the actuator and impair safe operation.

Stroking Range

The initial spring set listed on the nameplate has been determined to be the optimum setting, and it is not recommended to make spring adjustments that will cause this value to change or be exceeded. For push-down-to-open (PDTO) action, the initial spring set is normally the maximum allowable to provide the maximum spring closing force. Any increase of this setting could over-stress the spring at full travel. For push-down-to-close (PDTC) action, the initial spring set has been determined to be the optimum balance between the air to close and the spring to open breakout torque.

If the 1052 actuator is to be changed from one action to another (i.e., from PDTC to PDTO), first refer to the initial spring compression values listed in the table for keys 11 and 13 in the Parts List section. Then adjust the unit according to the procedures in the Initial Compression portion of this section.

Maintenance

Actuator parts are subject to normal wear and must be inspected and replaced as necessary. The frequency of inspection and replacement depends upon the severity of service conditions. Instructions are given below for disassembly and assembly of parts. Key numbers referenced in the following steps are shown in figure 12 for 1051 actuators and in figure 13 for 1052 actuators unless otherwise specified.

WARNING

Avoid personal injury or property damage from sudden release of process pressure or uncontrolled movement of parts. Before performing any maintenance operations:

- Do not remove the actuator from the valve while the valve is still pressurized.
- Always wear protective gloves, clothing, and eyewear when performing any maintenance operations to avoid personal injury.
- Disconnect any operating lines providing air pressure, electric power, or a control signal to the actuator. Be sure the actuator cannot suddenly open or close the valve.

- Use bypass valves or completely shut off the process to isolate the valve from process pressure. Relieve process pressure from both sides of the valve. Drain the process media from both sides of the valve.
- Vent the power actuator loading pressure and relieve any actuator spring precompression.
- Use lock-out procedures to be sure that the above measures stay in effect while you work on the equipment.
- The valve packing box may contain process fluids that are pressurized, *even when the valve has been removed from the pipeline*. Process fluids may spray out under pressure when removing the packing hardware or packing rings, or when loosening the packing box pipe plug.
- Check with your process or safety engineer for any additional measures that must be taken to protect against process media.

Disassembly

The following procedure describes how the actuator can be completely disassembled. When inspection or repairs are required, perform only those steps necessary to accomplish the procedure. Do not under ordinary circumstances remove the cap screws (keys 7, 8, and 21).

CAUTION

Cap screw (key 18) must be disengaged from the lever (key 27) before removing the diaphragm casing (key 1). Failure to do so will allow the spring precompression to rotate the valve body or other operated equipment beyond its fully open or closed position. This could cause damage to the operated equipment.

1. Bypass the valve or other operated equipment. Relieve all actuator loading pressure, and remove the tubing or pipe from the top of the actuator.
2. Remove the positioner, if one is used.
3. Mark the orientation of the travel indicator (key 37) with respect to the travel indicator scale (key 35). Then, unscrew the cap screws and washers (keys 34 and 63), and remove the cover (key 33).
4. Remove the retaining ring (key 30), and then remove the hub (key 29) from the cover.
5. Check the condition of the bearing (key 31). If replacement of the bearing is necessary, the travel indicator scale (key 35) must first be removed by removing the self-tapping screws (key 36). Mark the orientation of the travel indicator scale on the cover before removing it.

CAUTION

When removing the actuator from the valve body, do not use a hammer or similar tool to drive the lever (key 27) or actuator off the output shaft (key 87). Driving the lever or actuator could damage operated equipment. For valves, driving the lever (key 27) could move the valve disk and bearings away from the centered position causing subsequent damage to valve parts.

If necessary, use a wheel puller to remove the lever. It is permissible to tap the wheel puller screw lightly to loosen the lever, but hitting the screw with excessive force could also damage operated parts or disrupt the centered position of a valve disk or other equipment.

6. For an actuator with an H mounting adaptation and a 22.2 through 38.1 mm (7/8 through 1-1/2 inch) output shaft, unscrew the cap screws (key 78) and remove the actuator from the operated equipment. Mark the orientation of the lever (key 27) with respect to the output shaft (key 87). This marking is used during reassembly to allow for proper lever/output shaft positioning.

Then, loosen the cap screw (key 28) so that the output shaft is free to slide off the lever. With the lever and output shaft properly marked, unscrew the cap screws (key 23) and remove the mounting plate (key 22) and output shaft (key 87) assembly from the actuator housing (key 20). If necessary, remove the retaining ring (key 88) and separate the output shaft from the mounting plate.

7. For an actuator with a J mounting adaptation (see figures 12 and 13) with a 50.8 mm (2-inch) output shaft (see figure 14) and proceed as follows:
 - a. Remove the cap screws (key 78, not shown in figures 12 and 13) and remove the actuator from the operated equipment. For an actuator with J mounting and a 31.8 or 38.1 mm (1-1/4 or 1-1/2 inch) valve shaft diameter, two spacers (key 92, not shown in figures 12 and 13) are also removed with the cap screws (key 78).
 - b. When separating the output shaft (key 87) and coupling (key 90) from the operated shaft, remember to remove the woodruff key (key 91, not shown in figure 14) from the operated shaft keyway.
 - c. Mark the orientation of the lever (key 27, figures 12 and 13) with respect to the output shaft (key 87). This marking is used during reassembly to allow for proper lever/output shaft positioning.
 - d. Loosen the cap screw (key 28, figures 12 and 13) so that the output shaft is free to slide off the lever.
 - e. With the lever and output shaft properly marked, unscrew the cap screws (key 23) and remove either the mounting bracket (key 22, figures 12 and 13 for J mounting) or the mounting plate (key 22, figure 14 for H mounting) plus the attached output shaft (key 87) from the actuator housing (key 20).
 - f. If necessary, remove the retaining ring (key 88) and slide the mounting bracket or mounting plate off the output shaft.
8. Check the bearing (key 67) in the mounting bracket or mounting plate (key 22). Press out and replace the bearing if necessary.
9. Heat the hex nut (key 19) to 177°C (350°F) long enough for the thread-locking adhesive (high strength) (key 77) to lose its holding strength. Then, remove the cap screw and hex nut (keys 18 and 19), and remove the lever (key 27) from the housing.
10. Rotate the handwheel (if one is used) counter-clockwise until the handwheel is not compressing the spring (key 11).

⚠ WARNING

To avoid personal injury from precompressed spring force suddenly thrusting the upper diaphragm casing (key 1) away from the actuator, relieve 1052 spring compression, or carefully remove 1051 casing cap screws by following the instructions presented in the next two steps before proceeding further.

11. To relieve 1052 spring compression, insert a round rod into one of the slots in the lower bearing seat (key 73). Slot diameter is 9.5 mm (3/8 inch) for size 40 actuators, 15.9 mm (5/8 inch) for size 60 actuators, and 19.1 mm (3/4 inch) for size 70 actuators. Use the rod to rotate the lower bearing seat, and move it away from the actuator casings. Continue rotating the lower bearing seat until spring compression is completely removed.
12. Loosen, but do not remove, all casing cap screws (key 5). Make sure there is no spring force on the 1051 upper diaphragm casing. Unscrew and remove the cap screws and hex nuts (keys 5 and 6), and then remove the upper diaphragm casing and the diaphragm (key 3).
13. Proceed as appropriate:

For 1051 actuators,

- a. Read and follow the warning printed on the nameplate (key 56) located on the diaphragm plate (key 4).

- b. Pull the diaphragm plate (key 4) and attached parts out of the actuator. The spring (key 11), diaphragm rod (key 10), cap screw (key 9), spring seat (key 13), hex nut (key 58), turnbuckle (key 57), hex nut (key 16), and rod end bearing (key 17) will be attached to the diaphragm head.

▲ WARNING

For 1051 actuators, the diaphragm plate (key 4) may be wedged against the diaphragm rod (key 10), thereby preventing the spring compression from being relieved as the cap screw (key 9) is loosened. Dislodge the diaphragm head from the diaphragm rod by loosening the cap screw (key 9) one full turn and tapping the underside of the diaphragm head until it follows the cap screw disassembly. Failure to check for this situation before removing the cap screw (key 9) could cause personal injury due to the sudden release of spring compression as the cap screw is disengaged.

- c. Slowly remove the cap screw (key 9) while making sure that the diaphragm head is following the cap screw removal. Note that spring load will be zero before the cap screw is completely removed. Then separate the remaining parts of the assembly.

For 1052 actuators,

- a. Remove the rod end bearing (key 17), the hex nut (key 16), the turnbuckle (key 57), and the hex nut (key 58) from the diaphragm rod (key 10).
- b. Pull the diaphragm plate (key 4) and attached parts out of the actuator. Then remove the cap screw (key 9) to separate the diaphragm plate and the diaphragm rod.
- c. Proceed as appropriate:
 - For actuator designs without a set screw in the spring barrel (key 12), remove the actuator spring (key 11) from the actuator. If it is necessary to remove the adjuster (key 74) from the spring barrel during this procedure, heat the base of the adjuster to 177°C (350°F) long enough for the thread locking adhesive (high strength) (key 77) to lose its holding strength. Then, unscrew the adjuster from the spring barrel. If the spring seat and the lower bearing seat (key 13 and 73) are to be replaced, unscrew the lower bearing seat from the adjuster, and then remove the thrust bearing and the bearing races (keys 71 and 72) from the lower bearing seat.
 - For actuator designs with a set screw, (key 75), remove the actuator spring (key 11) from the actuator. If the spring seat and the lower bearing seat (keys 13 and 73) are to be replaced, unscrew the lower bearing seat from the adjuster, and then remove the thrust bearing and the bearing races (keys 71 and 72) from the lower bearing seat. If it is necessary to remove the spring adjustment parts, heat the set screw (key 75) to 177°C (350°F) long enough for the thread-locking adhesive (high strength) (key 77) to lose its holding strength, and then loosen the set screw (key 75). Unscrew the spring adjuster (key 74) from the spring barrel (key 12).

Assembly

This procedure assumes that the actuator is completely disassembled. If the actuator is not completely disassembled, start these instructions at the appropriate step. Key numbers used are shown in figure 12 for 1051 actuators and in figure 13 for 1052 actuators.

1. If the 1052 spring barrel (key 12) was removed from the housing (key 10), align the spring barrel to the housing as described below to ensure that the offset hole in the base of the spring barrel is located properly.

For size 40 and 60 actuators, note that one of the accessory mounting bosses on the spring barrel is closer to the diaphragm end of the spring barrel. Place the spring barrel on the housing with the upper boss (the one closer to the diaphragm end) on the same side as the boss located on the housing (see figure 13). This ensures proper positioning of the offset hole. Secure the spring barrel with the cap screws (key 21).

For size 70 actuators, the spring barrel need not be aligned in any particular position when placing it on the housing.

Note

Refer to table 11 for bolting torques for actuator bolts and cap screws. Exceeding any torque requirement may impair the safe operation of the actuator.

2. Proceed as appropriate:

For 1051 actuators,

- a. Coat the thread of the cap screw (key 9) and the tapered end of the diaphragm rod (key 10) with lithium grease (key 76).
- b. Assemble the diaphragm rod, spring seat (key 13), spring (key 11), and diaphragm plate (key 4), and secure with the cap screw (key 9). Tightening the cap screw will compress the spring. Be certain the tapered end of the diaphragm rod is seated in the corresponding hole in the diaphragm plate, that the spring is seated in the spring seat, and that the cap screw is tightened to the torque specified in table 11.
- c. Install the hex nut (key 58), turnbuckle (key 57), hex nut (key 16), and rod end bearing (key 17) onto the diaphragm rod.
- d. Be certain the travel stops (key 8) are located as shown in figure 11.
- e. Install the diaphragm plate and attached parts into the actuator.
- f. Be sure the warning nameplate (key 56) is in place. Install the diaphragm (key 3) and the upper diaphragm casing (key 1). Install the cap screws and hex nuts (keys 5 and 6). Tighten the cap screws evenly in a crisscross pattern to compress the spring and secure the upper diaphragm casing. Tighten these cap screws to the torques shown in table 11.

For 1052 actuators,

- a. Proceed as appropriate:
- For actuator designs without a set screw in the spring barrel (key 12), if the adjustor and attached parts were removed, first clean and then lubricate the upper threads of the adjustor (key 74) with lithium grease (key 76) as shown in figure 13. Install the lower bearing seat (key 73), the thrust bearing (key 71), the thrust bearing races (key 72), and the spring seat (key 13) onto the adjustor. Then, first clean and then coat the lower end of the adjustor with thread-locking adhesive (high strength) (key 77) as shown in figure 13, and install the entire assembly into the spring barrel (key 12). Let the adjustor stand undisturbed for at least two hours after installation to allow the thread-locking compound to cure.

CAUTION

When applying lubricant to the upper threads and thread-locking compound to the lower threads of the adjustor, do not overlap the coat of lubricant with the coat of thread-locking compound since this will adversely affect the performance quality of both substances.

- For actuator designs with a set screw, (key 75), if the adjustor (key 74) and attached parts were removed, lubricate the threads of the adjustor with lithium grease (key 76). Install the lower bearing seat (key 73), the thrust bearing

- (key 71), the thrust bearing races (key 72), and the spring seat (key 13) onto the adjustor. Install this assembly into the spring barrel (key 12). After first cleaning and then coating the set screw (key 75) with thread-locking adhesive (high strength) (key 77), secure the adjustor with the set screw (key 75).
- b. Coat the tapered end of the diaphragm rod (key 10) and the threads of the cap screw (key 9) with lithium grease (key 76). Bolt the diaphragm plate (key 4) to the diaphragm rod with the cap screw (key 9). Tighten the cap screw to the torque value listed in table 11.
 - c. Be certain the travel stops (key 8) are located as shown in figure 11.
 - d. Install the spring (key 11) into the spring barrel. Install the diaphragm plate and diaphragm rod into the actuator. Attach the hex nut (key 58), turnbuckle (key 57), hex nut (key 16), and rod end bearing (key 17) to the diaphragm rod.
 - e. Install the diaphragm (key 3).
 - f. Place the upper diaphragm casing (key 1) on the lower diaphragm casing (key 2). If necessary, rotate the lower bearing seat (key 73) so that the upper diaphragm casing travel stop will not contact the diaphragm when the casing cap screws (key 5) are tightened. Secure the upper diaphragm casing with the cap screws and hex nuts (keys 5 and 6) in a criss-cross pattern to the torques shown in table 11. Be sure the warning nameplate is in place on the casing.
3. If the bearing (key 67) was removed, press in the new bearing. The end of the bearing should be flush with the outside of the mounting bracket or mounting plate (key 22).
 4. For an actuator with an **H mounting** adaptation, install the output shaft (key 87) through the mounting plate (key 22) and secure it with the retaining ring (key 88). Then, attach the mounting plate and output shaft assembly to the actuator housing (key 20) with the cap screws (key 23). Tighten the cap screws to the appropriate torque value listed in table 11.
 5. For an actuator with a **J mounting** adaptation, refer to figures 12 and 13. Install the output shaft (key 87) with attached coupling (key 90) through the mounting bracket (key 22) and secure it with the retaining ring (key 88). Attach the mounting bracket and output shaft assembly to the actuator housing (key 20) with the cap screws (key 23). Tighten the cap screws to the appropriate torque value listed in table 11.
 6. For an actuator with a **J mounting** adaptation and a **50.8 mm (2-inch) output shaft**, refer to figure 14. Install the output shaft (key 87) with attached coupling (key 90) through the mounting plate (key 22) and secure it with the retaining ring (key 88). Attach the mounting plate and output shaft assembly to the actuator housing with the cap screws (key 23). Tighten the cap screws to the appropriate torque value listed in table 11.
 7. Apply lithium grease (key 76) to the output shaft splines. Then, align the lever (key 27) and output shaft so that the marking that was made in step 6 or 7 of the Disassembly procedure is oriented correctly. Slide the lever into place. When installing the lever, align the bolt holes in the lever as close as possible with the hole in the rod end bearing (key 17). Temporarily rotate the lever and output shaft until the rod end bearing no longer interferes with further installation of the lever. Then, slide the lever as far as it can go onto the output shaft.
 8. Clamp the lever to the output shaft with the cap screw (key 28). Tighten the cap screw to the torque value listed in table 11.
 9. For 1052 actuators, complete the Initial Compression portion of the Adjustment section before proceeding.
 10. Rotate the lever (key 27) to align with the rod end bearing (key 17). This connection can be aided by stroking the actuator off its up travel stop with a regulated air source.

Figure 10. Actuator Housing Construction Styles and Mounting Positions

DESIRED ACTION OF		HOUSING CONSTRUCTION TO SPECIFY
Actuator	Operated Equipment	
Push Down to Open ⁽¹⁾ (PDTO)	Clockwise to Close ⁽³⁾	Style A
	Counterclockwise to Close ⁽³⁾	Style B
Push Down to Close ⁽²⁾ (PDTC)	Clockwise to Close ⁽³⁾	Style B
	Counterclockwise to Close ⁽³⁾	Style A

1. This action uses the spring to close the valve body or other equipment.
 2. This action uses the spring to open the valve body or other equipment.
 3. When viewed from actuator side of valve body or other equipment.

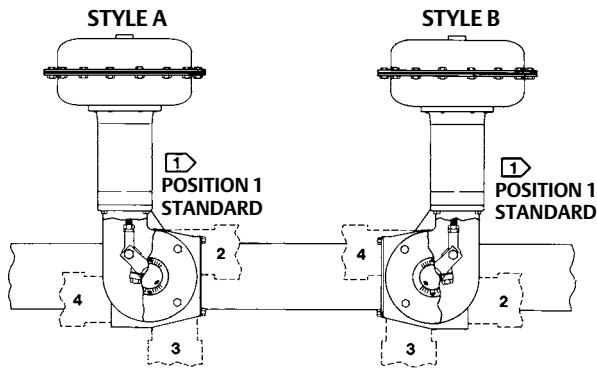

NOTE:
 1 DOTTED LINES INDICATE ALTERNATE MOUNTING POSITIONS 2, 3, AND 4.

43A6505-A
 A1578-3

11. Apply thread-locking adhesive (high strength) (key 77) to the threads of the cap screw (key 18).
12. Connect the lever (key 27) and the rod end bearing (key 17) with the cap screw and hex nut (keys 18 and 19). Tighten the cap screw to the torque value listed in table 11.
13. If a positioner is to be used, consult the separate positioner instruction manual for proper positioner installation.
14. Coat the bearing surfaces of the hub (key 29) and cover (key 33) with lithium grease (key 76). Install the bearing (key 31) and hub into the cover. Secure with the retaining ring (key 30).
15. Install the travel indicator scale (key 35) so that the markings on the scale and cover that were made in step 5 of the Disassembly procedure are oriented correctly. Secure the travel indicator scale to the cover with the self-tapping screws (key 36). Then install the travel indicator (key 37), and secure it with the self-tapping screws (key 38).
16. Position the travel indicator (key 37) so that the markings on the travel indicator and travel indicator scale that were made in step 3 of the Disassembly procedure are oriented correctly. Then, replace the cover (key 33), and secure it with the cap screws and washers (keys 34 and 63). If the holes in the cover and housing (key 20) do not align, use a regulated air source to move the actuator slightly off the up travel stop. If hole alignment cannot be obtained in this manner, temporarily loosen the cap screws (key 23), and shift the housing slightly. Do not stroke the actuator while the cover is off. Tighten the cap screws to the torque value listed in table 11.
17. Follow the instructions in the Actuator Mounting section for correct actuator mounting and adjustment. Remember to replace the access plate (key 59) when performing this procedure.

Changing Actuator Mounting

The actuator is normally positioned vertically in a horizontal pipeline. However, each style can be mounted in two possible mounting styles and four possible positions (see figure 10).

Note

Due to its weight, the 1052, size 70 actuator must be externally supported if mounted in the horizontal position.

⚠ WARNING

Before performing any Actuator Mounting steps, follow the steps in the WARNING at the beginning of the Maintenance section.

Use the following procedures along with figures 12 and 13 for key number references to convert from style A to style B or vice versa or to change the mounting position.

Changing Styles

1. Unscrew the cap screws and washers (keys 34 and 63), and remove the cover (key 33).
2. Heat the hex nut (key 19) to 177°C (350°F) long enough for the thread-locking adhesive (high strength) (key 77) to lose its holding strength. Then, remove the cap screw and hex nut (keys 18 and 19).
3. Loosen the cap screw (key 28).

CAUTION

If necessary, use a wheel puller to remove the lever (key 27) from the output shaft (key 87). It is permissible to tap the wheel puller screw lightly to loosen the lever, but hitting the screw with excessive force could damage the operated equipment.

4. Mark the side of the lever (key 27) that is nearest to the end of the output shaft (key 87). This marking is used during reassembly to determine which side of the lever should be inserted into the actuator housing first. When the lever is marked, remove the lever.
5. For an actuator with a J mounting adaptation,
 - a. Unscrew the cap screws (key 23), and remove the actuator housing (key 20) from the mounting bracket (key 22).
 - b. Rotate the actuator housing 180 degrees, maintaining the appropriate position (1, 2, 3, or 4), and place the actuator onto the mounting bracket (key 22).
 - c. Secure the actuator housing to the mounting bracket with the cap screws (key 23). Tighten the cap screws to the torque value listed in table 11.
6. For an actuator with an H mounting adaptation,
 - a. Unscrew the cap screws (key 78) and remove the actuator assembly from its mounting bracket.

- b. Unscrew the cap screws (key 23) and remove the mounting plate (key 22) and output shaft (key 87) assembly from the actuator housing. Remount the assembly on the opposite side of the actuator, and secure it to the housing with the cap screws (key 23). Tighten the cap screws to the torque value listed in table 11.
 - c. Rotate the actuator housing 180 degrees, maintaining the appropriate position (1, 2, 3, or 4) and secure the actuator housing to the mounting bracket with the cap screws (key 78). Tighten the cap screws to the torque value listed in table 4.
7. Install the lever (key 27) as follows:
- a. For push-down-to-open action, rotate the operated equipment to the fully closed position.
 - b. For push-down-to-close action, rotate the operated equipment to the fully open position.
 - c. With the operated equipment oriented correctly, slide the lever onto the output shaft (key 87) with the end marked in step 4 inserted first. When installing the lever, align the bolt holes in the lever as close as possible with the hole in the rod end bearing (key 17).
 - d. Temporarily rotate the lever and output shaft until the rod end bearing no longer interferes with further installation of the lever. Then, slide the lever as far as it can go onto the output shaft. Clamp the lever to the output shaft with the cap screw (key 28). Tighten the cap screw to the torque value listed in table 11.
 - e. Rotate the lever and output shaft back to the original position (i.e., operated equipment fully closed for push-down-to-open action or operated equipment fully open for push-down-to-close action). Then, adjust the rod end bearing so that it can be attached to the lever.
8. Apply thread-locking adhesive (high strength) (key 77) to the threads of the cap screw (key 18).
9. Connect the lever (key 27) and the rod end bearing (key 17) with the cap screw and hex nut (keys 18 and 19). This connection can be aided by stroking the actuator from its up travel stop with a regulated air source. Tighten the cap screw to the torque value listed in table 11.
10. Note the position of the valve body or other operated equipment and direction of rotation. Position the travel indicator (key 37) accordingly. Replace the cover (key 33), and secure it with the cap screws and washers (keys 34 and 63). If the holes in the cover and housing (key 20) do not align, use a regulated air source to move the actuator slightly off the up travel stop. If hole alignment cannot be obtained in this manner, temporarily loosen the cap screws (key 23), and shift the housing slightly. Do not stroke the actuator while the cover is off. Tighten both sets of cap screws to the torque values listed in table 11.
11. Follow the instructions in the Turnbuckle Adjustment section.

Changing Positions

1. Unscrew the cap screws and washers (keys 34 and 63), and remove the cover (key 33).
2. Mark the orientation of the lever (key 27) with respect to the output shaft (key 87). This marking is used during reassembly to allow for proper lever/output shaft positioning. When the lever and output shaft are properly marked, heat the hex nut (key 19) to 177°C (350°F) long enough for the thread-locking adhesive (high strength) (key 77) to lose its holding strength. Then, remove the cap screw and hex nut (keys 18 and 19).

CAUTION

If necessary, use a wheel puller to remove the lever (key 27) from the output shaft (key 87). You may tap the wheel puller screw lightly to loosen the lever, but hitting the screw with excessive force could damage the operated equipment.

3. Loosen the cap screw (key 28) and remove the lever (key 27) from the output shaft (key 87).

4. For an actuator with a J mounting adaptation.
 - a. Unscrew the cap screws (key 23), and remove the actuator housing (key 20) from the mounting bracket (key 22).
 - b. Rotate the actuator housing to the new position (1, 2, 3, or 4).
 - c. Secure the actuator housing to the mounting bracket with the cap screws (key 23). Tighten the cap screws to the torque value listed in table 11.
5. For an actuator with an H mounting adaptation.
 - a. Unscrew the cap screws (key 78) and loosen the actuator assembly from its mounting bracket.
 - b. Rotate the actuator housing to the new position (1, 2, 3, or 4).
 - c. Secure the actuator housing to the mounting bracket with the cap screws (key 78). Tighten the cap screws to the torque value listed in table 4.
6. Referring to the alignment marks that were made in step 2, install the lever (Key 27) onto the output shaft (key 87) as follows:
 - a. If the new actuator position is 90 degrees clockwise from the previous actuator position, install the lever so that its orientation mark is located 90 degrees clockwise from the mark on the output shaft.
 - b. If the new actuator position is 90 degrees or 180 degrees counterclockwise from the previous position, install the lever so that its orientation mark is located either 90 degrees (for 90 degrees) or 180 degrees (for 180 degrees) counterclockwise (respectively) from the mark on the output shaft.
 - c. Slide the lever onto the output shaft with the bolt holes in the lever aligned as closely as possible with the hole in the rod end bearing (key 17). Then, temporarily rotate the lever and output shaft until the rod end bearing no longer interferes with further installation of the lever, and slide the lever as far as it can go onto the output shaft. Clamp the lever to the output shaft with the cap screw (key 28). Tighten the cap screw to the torque value listed in table 11.
 - d. Rotate the lever and output shaft back to the original position, and then adjust the rod end bearing so that it can be attached to the lever.
7. Apply thread-locking adhesive (high strength) (key 77) to the threads of the cap screw (key 18).
8. Connect the lever (key 27) and the rod end bearing (key 17) with the cap screw and hex nut (keys 18 and 19). This connection can be aided by stroking the actuator from its up travel stop with a regulated air source. Tighten the cap screw to the torque value listed in table 11.
9. Note the position of the valve body or other operated equipment and direction of rotation. Position the travel indicator (key 37) accordingly. Replace the cover (key 33), and secure it with the cap screws and washers (keys 34 and 63). If the holes in the cover and housing (key 20) do not align, use a regulated air source to move the actuator slightly off the up travel stop. If hole alignment cannot be obtained in this manner, temporarily loosen the cap screws (key 23), and shift the housing slightly. Do not stroke the actuator while the cover is off. Then, tighten both sets of cap screws to the torque values listed in table 11.
10. Follow the instructions in the Turnbuckle Adjustment section.

Figure 11. Travel Stop Orientation

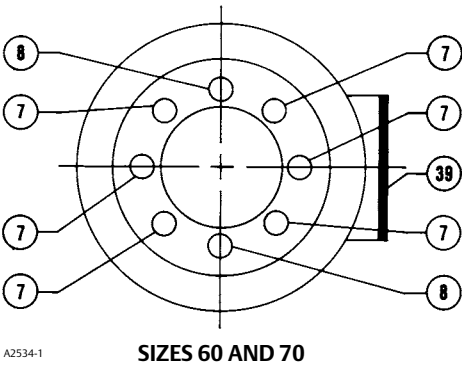
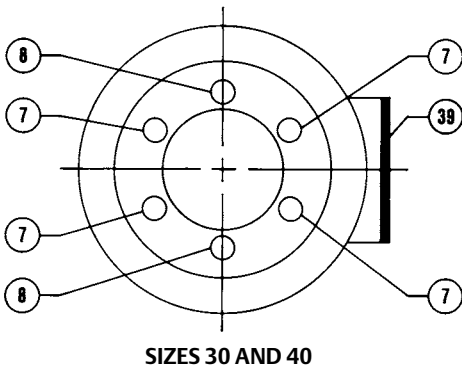

Top-Mounted Handwheels and Adjustable Travel Stops

Handwheel and Travel Stop Operation

Note

If repeated or daily manual operation is expected or desired, the unit should be equipped with a manual handwheel actuator. Refer to the separate manual handwheel actuator instruction manual for mounting instructions.

The top-mounted handwheel assembly is attached to a special upper diaphragm casing (key 1, figures 12 and 13) with cap screws (key 141, figure 15). A hex nut (key 137, figure 15) locks the handwheel in position.

Turning the handwheel (key 51, figure 15) clockwise into the upper diaphragm casing forces the pusher (key 135, figure 15) against the diaphragm and diaphragm plate (keys 3 and 4, figures 12 and 13) to compress the spring (key 11, figures 12 and 13) and move the diaphragm rod downward. Turning the handwheel counterclockwise allows the actuator spring to move the diaphragm rod upward. If the action is push-down-to-close, full opening can be restricted by positioning the handwheel at the desired position. If the action is push-down-to-open, full closing can be restricted by use of the handwheel.

The adjustable up travel stop (figure 16) limits the actuator stroke in the upward direction. To make adjustments, first relieve actuator loading pressure before removing the closing cap (key 187) as it is a pressure retaining part. Also, for size 70 actuators, the hex nut (key 137) must be loosened.

Turning the stem (key 133) clockwise into the diaphragm case moves the actuator stem downward or counterclockwise to allow the spring to move the actuator stem upward. If the action is push-down-to-close, full opening can be restricted; or if the action is push-down-to-open, full closing can be restricted by the position of the adjustable travel stop.

The adjustable down travel stop (figure 17) limits the actuator stroke in the downward direction. To make adjustments, first relieve actuator loading pressure before removing the closing cap (key 187) as it is a pressure retaining part. After removing the closing cap, loosen the hex jam nut (key 189) and either turn the hex nut (key 63 for size 40, and 70 actuators; or key 54 for size 60 actuators) down on the stem (key 133) to limit travel, or up on the stem to allow more travel. Lock the jam nut against the hex nut and replace the closing cap after the adjustment has been made. For size 70, tighten the hex nut and replace the closing cap after adjustment.

Handwheel and Travel Stop Maintenance

▲ WARNING

Avoid personal injury or property damage from sudden release of process pressure or uncontrolled movement of parts. Before performing any maintenance operations:

- Do not remove the actuator from the valve while the valve is still pressurized.
- Always wear protective gloves, clothing, and eyewear when performing any maintenance operations to avoid personal injury.
- Disconnect any operating lines providing air pressure, electric power, or a control signal to the actuator. Be sure the actuator cannot suddenly open or close the valve.
- Use bypass valves or completely shut off the process to isolate the valve from process pressure. Relieve process pressure from both sides of the valve. Drain the process media from both sides of the valve.
- Vent the power actuator loading pressure and relieve any actuator spring precompression.
- Use lock-out procedures to be sure that the above measures stay in effect while you work on the equipment.
- The valve packing box may contain process fluids that are pressurized, *even when the valve has been removed from the pipeline*. Process fluids may spray out under pressure when removing the packing hardware or packing rings, or when loosening the packing box pipe plug.
- Check with your process or safety engineer for any additional measures that must be taken to protect against process media.

If loading pressure seems to be leaking from either the handwheel or adjustable up stop, the O-rings (key 138 and 139, figures 15 and 16) may need replacement. If the adjustable down stop leaks, the O-ring (key 139, figure 17) may need replacement or possibly the closing cap (key 187, figure 17) is not tight. To tighten the closing cap, apply a good grade of thread sealant to the closing cap threads.

For ease of operation, the stem (key 133, figures 15, 16, and 17) threads may need an occasional application of lithium grease. A grease fitting (key 169, figures 15 and 16) is provided for this purpose in the size 70. The size 70 may also need to have the thrust bearing (key 175, figures 15 and 16) packed with lithium grease. Travel stops for the smaller casings can be lubricated between the stem and pusher (key 135, figures 15 and 16) with lithium grease.

1. Bypass the control valve, reduce loading pressure to atmospheric, and remove the tubing or pipe from the body (key 142, figures 15, 16, and 17).

⚠ WARNING

To avoid personal injury from the precompressed spring force thrusting the upper diaphragm casing (key 1, figures 12 and 13) away from the actuator, either relieve 1052 spring compression, or carefully remove 1051 casing cap screws by following the instructions that are referenced in the steps below before removing the casing.

2. Relieve all actuator spring compression by following the procedures presented in the Disassembly portion of the Maintenance section. Then, rotate either the handwheel (key 51, figure 15) or the travel stop stem (key 133, figures 16 and 17) counterclockwise until the handwheel or travel stop assembly is no longer compressing the spring.
3. Proceed as appropriate:

For Top-Mounted Handwheels and Adjustable Up Travel Stops

- a. Remove the upper diaphragm casing (key 1, figures 12 and 13) by following steps 1, 3, 6, 7, 9, 11, and 12 of the Disassembly portion of the Maintenance section.
- b. Remove the cap screws (key 141, figures 15 and 16, and separate the assembly from the upper casing.
- c. Loosen the locknut (key 137, figure 15) or remove the closing cap (key 187, figure 16).
- d. Turn the stem (key 133, figures 15 and 16) clockwise out of the body. On handwheel assemblies, the cotter pin and slotted nut (keys 247 and 54, figure 15) will have to be removed so that the handwheel (key 51, figure 15) and locknut can be taken off the stem first.
- e. Remove and inspect the O-rings (keys 138 and 139, figures 15 and 16); replace them if necessary.
- f. To complete disassembly for sizes 40 and 60, drive out the groove pin (key 140, figures 15 and 16), and slide the pusher (key 135, figures 15 and 16) off the stem. The pusher of a size 70 unit is held to the stem by a retaining screw (key 174, figures 15 and 16). Removing the retaining screw and pusher exposes the thrust bearing (key 175, figures 15 and 16) for inspection.

For Adjustable Down Travel Stops

Refer to figure 17 for appropriate key numbers unless otherwise stated.

- a. Remove the closing cap (key 187), and unscrew the jam nut and hex nut (keys 189 and 63 for sizes 40, and 70 actuators; or keys 189 and 54 for size 60 actuators) off the stem (key 133).
 - b. Remove the upper diaphragm casing (key 1, figures 12 and 13) and travel stop body (key 142) by following steps 1, 3, 6, 7, 9, 11, and 12 of the Disassembly portion of the Maintenance section.
 - c. Unscrew cap screws (key 141), and remove the body from the diaphragm case.
 - d. Check the condition of the O-ring (key 139), and replace it if necessary.
 - e. Loosen the hex nut (key 54), and then unscrew the travel stop stem (key 133) out of the actuator stem. The lower diaphragm plate (key 82) can now be removed and the rest of the actuator disassembled.
4. Reassemble by reversing the order of the steps you took to disassemble, being sure to apply lubricant as previously mentioned and as shown by the lubrication boxes (key 241) in figures 15 and 16. For size 70 handwheels or up travel stop assemblies, coat the threads of the retaining screws (key 174, figures 15 and 16) with thread-locking adhesive (high strength) (key 242).

5. Adjust the spring to obtain the appropriate travel stop restriction by following the procedures presented in the introductory portion of this section, and then return the unit to operation.

Parts Ordering

When corresponding with your [Emerson sales office](#) about this equipment, refer to the serial number found on the actuator nameplate (key 41, figure 12).

⚠ WARNING

Use only genuine Fisher replacement parts. Components that are not supplied by Emerson Automation Solutions should not, under any circumstances, be used in any Fisher valve, because they may void your warranty, might adversely affect the performance of the valve, and could cause personal injury and property damage.

Parts List

Retrofit Kits

Kit provides parts to add a top-mounted handwheel. Kit number 1 includes the handwheel assembly only. Kit number 2 includes Kit number 1 and a new upper case (key 1) that is required to mount the handwheel assembly.

Key	Description	Part Number
	1052 Actuator	
	Kit Number 1	
	Size 40	38A1213X032
	Size 60, Push-Down-to-Close	38A1213X062
	Size 60, Push-Down-to-Open	38A1213X052
	Kit Number 2	
	Size 40	38A1213X072
	Size 60, Push-Down-to-Close	38A1213X022
	Size 60, Push-Down-to-Open	38A1213X042
	1052 Actuator	
	Kit Number 1	
	Size 40	38A1213X032
	Size 60, Push-Down-to-Close	38A1213X062
	Size 60, Push-Down-to-Open	38A1213X052
	Size 70	CV8010X0012
	Kit Number 2	
	Size 40	38A1213X072
	Size 60, Push-Down-to-Close	38A1213X022
	Size 60, Push-Down-to-Open	38A1213X042
	Size 70	CV8010X0022

Common Parts (figures 12 and 13)

Note

Contact your Emerson sales office for part ordering information.

The size 70 actuator is available only in 1052 actuators.

Key	Description
1	Casing, Upper
2	Diaphragm Casing, Lower
3*	Diaphragm
4	Diaphragm Head
5	Screw, Cap, Hex hd
	Size 40 (16 req'd)
	Size 60 (24 req'd)
	Size 70 (28 req'd)
6	Nut, hex
	Size 40 (16 req'd)
	Size 60 (24 req'd)
	Size 70 (28 req'd)
7	Screw, cap, Hex hd
	Size 40 (4 req'd)
	Size 60 (6 req'd)
	Size 70 (10 req'd)
8	Travel Stop (2 req'd)
9	Screw, cap, Hex socket
10	Diaphragm Rod
11	Spring
12	Spring barrel

Figure 12. Fisher 1051 Actuator with Typical H and J Mounting Adaptations

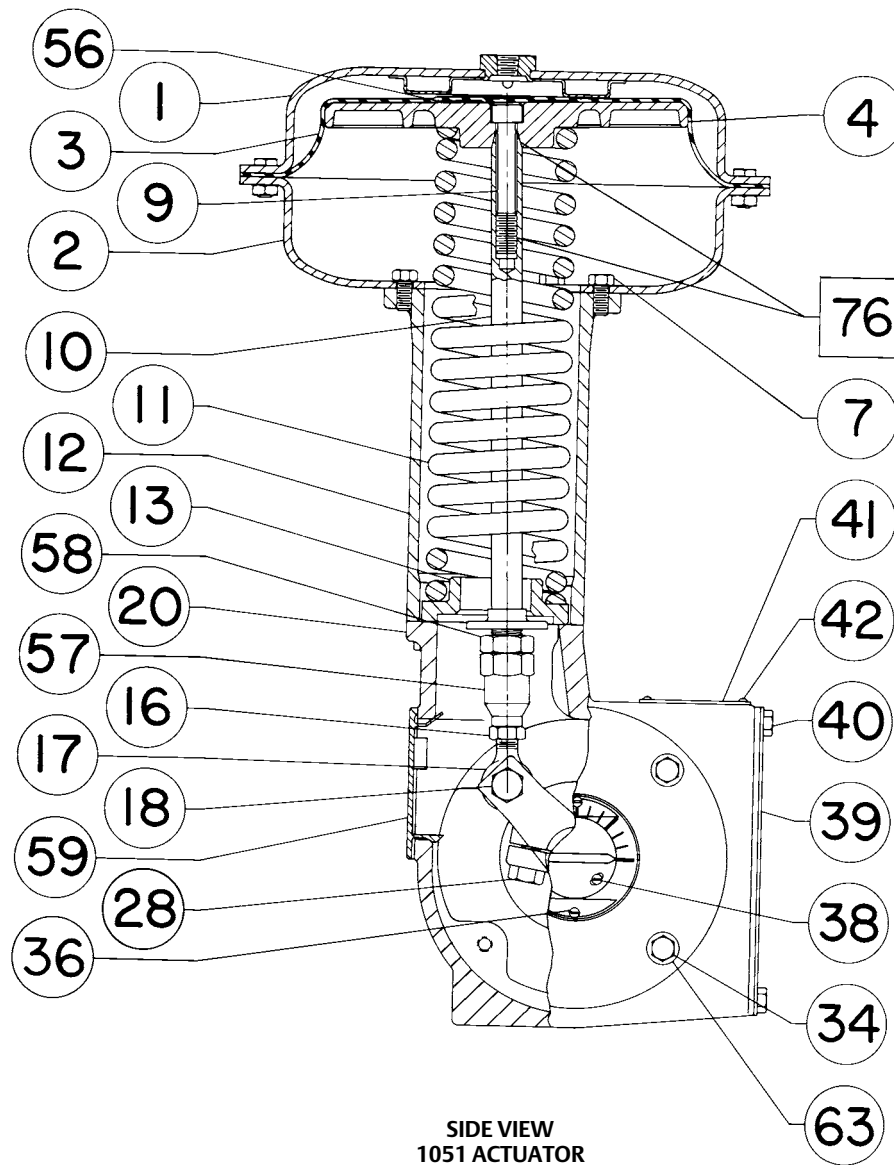

NOTES:
1. KEYS 12 AND 21 ARE NOT REQUIRED FOR SIZE 30 ACTUATORS.
2. KEYS 56, 82, 78, AND 92 ARE NOT SHOWN.
□ APPLY LUBRICANT / SEALANT
D0299-1

Key	Description	Key	Description
13	Spring seat	23	Screw, Cap, Hex socket (4 req'd)
16	Nut, hex	27	Lever
17	Bearing, Rod End	28	Screw cap, Hex Hd
18	Screw, cap, Hex hd	29	Hub
19	Nut, Hex, Jam	30	Retaining Ring, Ext
20	Housing	31*	Bushing (2 req'd)
21	Screw, Cap, Hex Hd (4 req'd)	33	Cover
22	Plate, mounting	34	Screw, Cap, Hex Hd
		34	Stud post (not shown)(w/ 3555T)(4 req'd)

Figure 12. Fisher 1051 Actuator with Typical H and J Mounting Adaptations (continued)

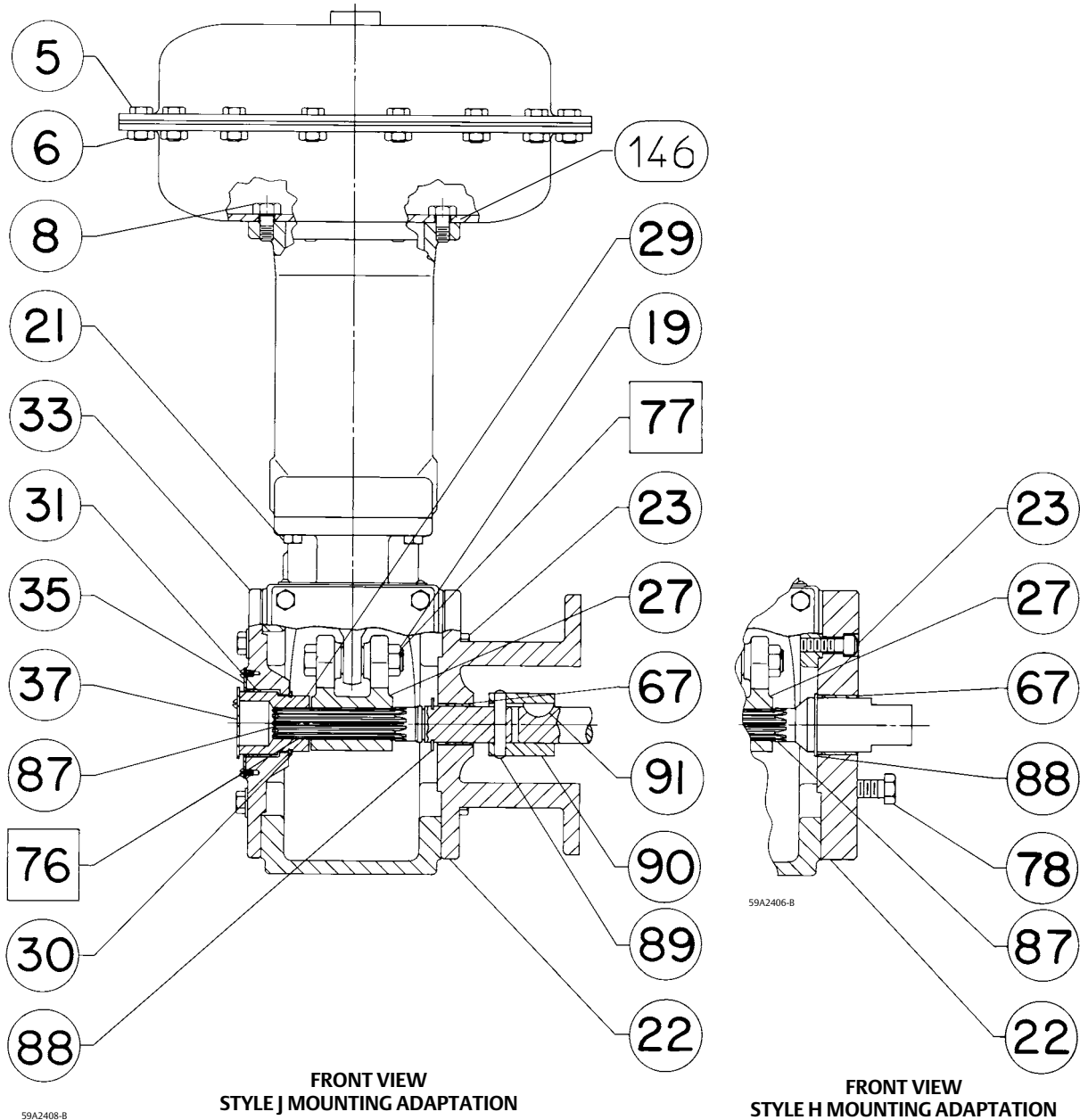
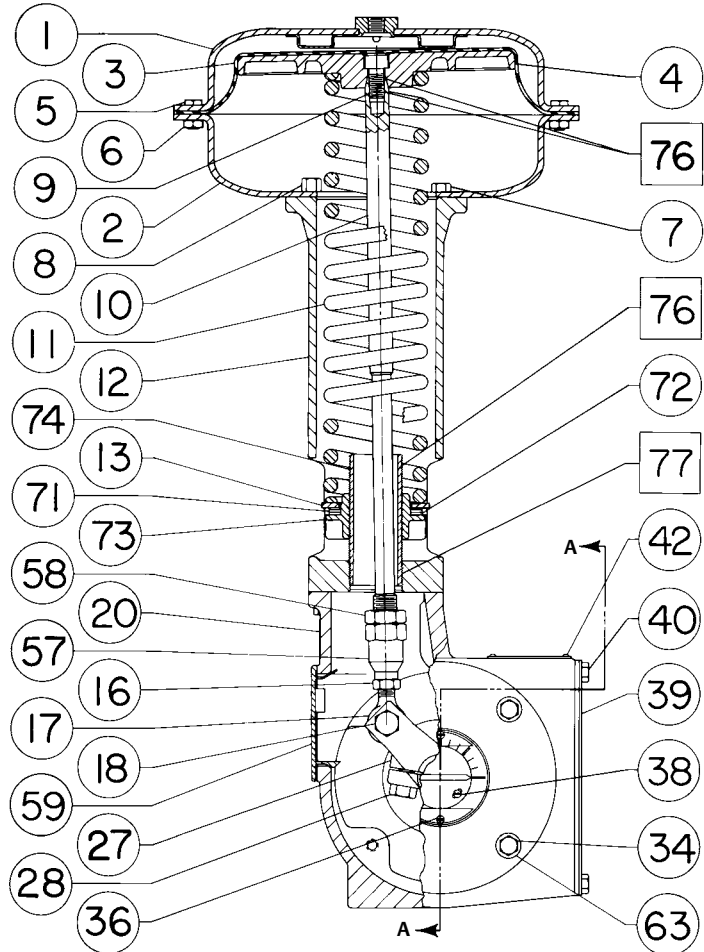

Figure 13. Fisher 1052 Actuator with Typical H and J Mounting Adaptations



**SIDE VIEW
1052 ACTUATOR**

59A2420-A
D0300-1

- NOTES:**
1. KEYS 56, 82, 78, AND 92 ARE NOT SHOWN.
□ APPLY LUBRICANT / SEALANT

Figure 13. Fisher 1052 Actuator with Typical H and J Mounting Adaptations (continued)

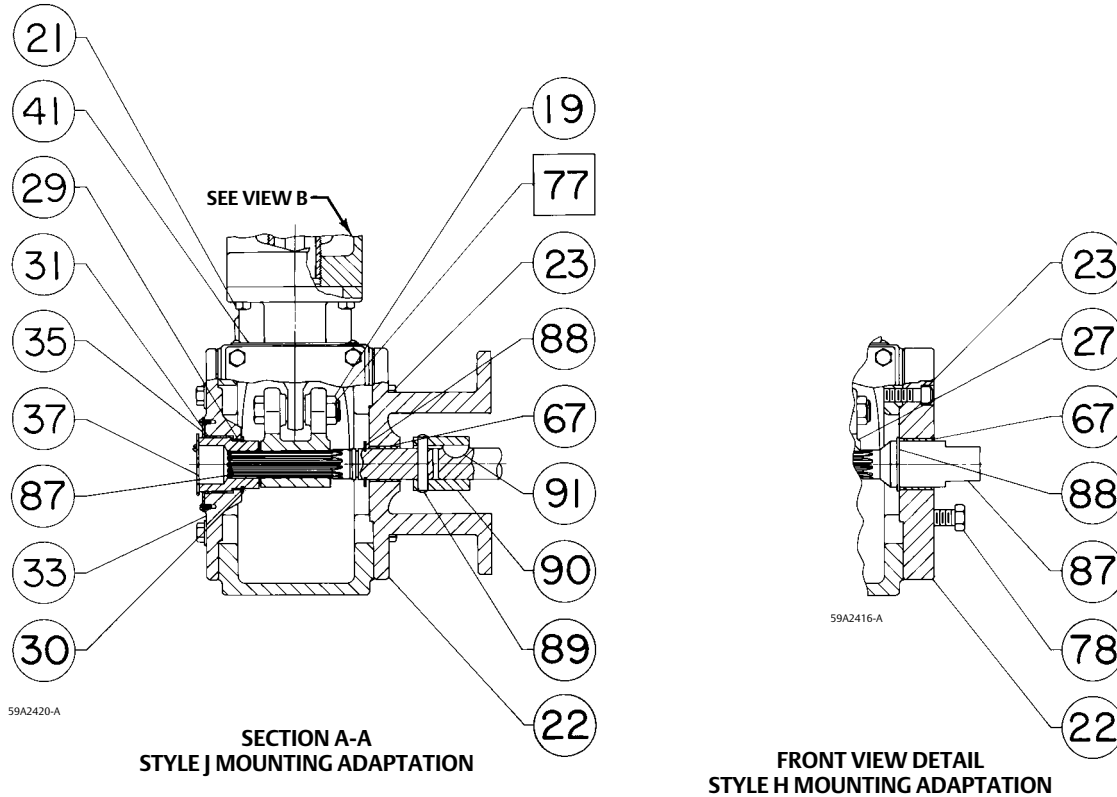

Key Description

- 35 Scale, Indicator (w/out handwheel or w/ 3555T)
- 36 Screw, Self Tap (2 req'd)
- 37 Travel Indicator
- 38 Self-Tapping Screw (2 req'd)
- 38 Machine Screw (2 req'd)
- 39 Plate, Cover
- 40 Screw, Cap, Hex hd
w/o 3610J/3620J Positioner (4 req'd)
- 41 Nameplate
- 42 Screw, Drive (4 req'd)
- 56 Nameplate
- 57 Turnbuckle
- 58 Nut, Hex, Jam
- 59 Plate, Access
- 63 Washer, Plain
Size 40 (4 req'd)
Sizes 60 & 70 (2 req'd)
- 64 Ind, Travel (not shown)(w/ 3555T)
- 65 Screw, Mach, Fill hd (w/ 3555T)
- 66 Disk, Travel Indicator (w/ 3555T) (not shown)
- 67* Bushing
- 71 Bearing, Thrust (1052)
- 72 Bearing race (1052) (2 req'd)
- 73 Bearing Seat (1052, Sizes 60 & 70)
- 74 Screw, adjusting (1052)

Key Description

- 76 Lithium Grease (not furnished w/actuator)
- 77 Thread Locking Adhesive (High Strength)
(not furnished w/actuator)
- 78 Cap Screw, Hex Hd
Style H
Size 40 (4 req'd)
Size 60 (4 req'd)
Style J
Size 30/40 (2 req'd)
w/15.9 mm (5/8-inch) actuator output shaft (4 req'd)
Size 40 (4 req'd)
Size 60 (4 req'd)
w/50.4 mm (2-inch) actuator output shaft (1 req'd)
- 82 Diaphragm head, lower (1051 w/adj down stop)
- 83 Plug, protective (1052 Size 70)
- 87 Actuator Output Shaft
- 88 Retaining Ring
- 89* Pin, Groove
- 90 Coupling
- 91* Key, Woodruff
- 92 Spacer (not shown) (2 req'd)
- Bushing, Pipe (not shown) (1052 Size 70)
- 146 Spacer (1 req'd)

Figure 14. H Mounting for 44.5 or 50.8 mm (1-3/4 or 2-Inch) Keyed Equipment Shafts

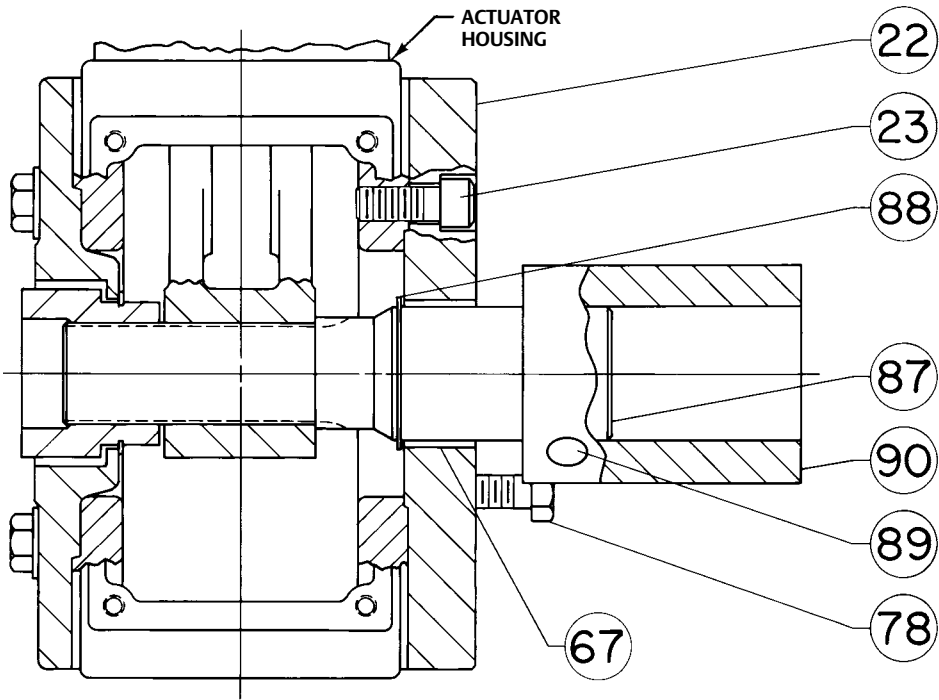

39A2401-A
A3245-1

Key Description

Figure 15. Top-Mounted Handwheel Assemblies

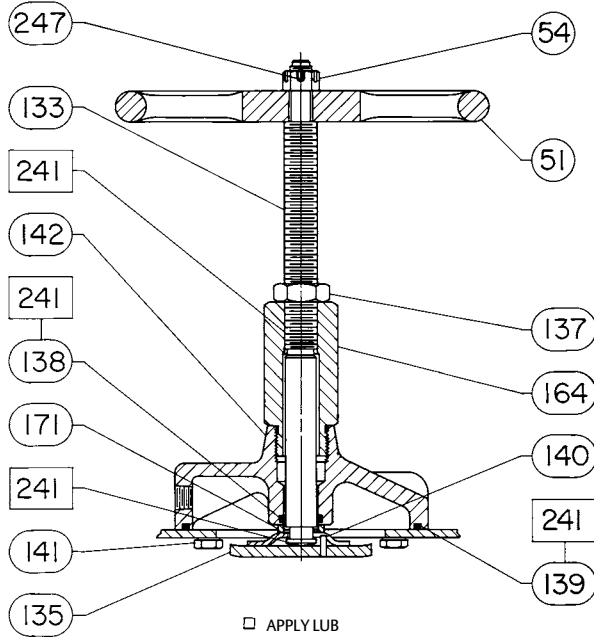

38A1213-B

TOP-MOUNTED HANDWHEEL ASSEMBLY FOR SIZE 30, 40, AND 60 ACTUATORS

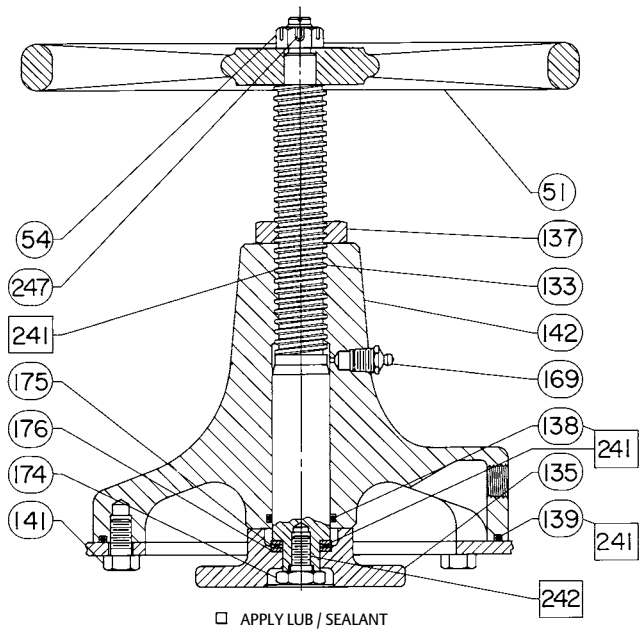

CV8010-E

TOP-MOUNTED HANDWHEEL ASSEMBLY FOR SIZE 70 ACTUATORS

Top-Mounted Handwheel (figure 15)

Key Description

- 51 Handwheel
- 54 Hex Nut, Slotted
- 133 Stem
- 135 Plate, Pusher
- 137 Hex Nut, Jam
- 138* O-Ring
- 139* O-Ring
- 140 Groove Pin (Sizes 40 & 60)
- 141 Cap Screw, Hex hd
 - Size 40 (6 req'd)
 - Size 60 (8 req'd)
 - Size 70 (12 req'd)

Key Description

- 142 Body
- 164 Body Extension (Sizes 40 & 60)
- 169 Grease Fitting (Size 70)
- 171 Spacer (Size 60)
- 174 Retaining Screw (Size 70)
- 175 Thrust Bearing (Size 70)
- 241 Lithium Grease (not furnished w/travel stop)
- 242 Thread Locking Adhesive (High Strength) (not furnished w/travel stop) (1052 Size 70 only)
- 246 Spacer (Sizes 60 & 70)
- 247 Pin, Cotter

Adjustable Up Travel Stop (figure 16)

Key	Description
133	Stem
135	Plate, Pusher
137	Nut, Travel Stop (Size 70)
138*	O-Ring
139*	O-Ring
140*	Groove Pin
141	Cap Screw, Hex Hd Size 40 (6 req'd) Size 60 (8 req'd) Size 70 (12 req'd)
142	Body
164	Body Extension (Sizes 40 & 60)
169	Grease Fitting (Size 70)
171	Spacer (Size 60)
174	Retaining Screw (Size 70)
175	Thrust Bearing
176	Bearing Race, Thrust (1052, Size 70) (2 req'd)
187	Travel stop cap (Size 70)
241	Lithium Grease (not furnished w/travel stop)
242	Thread Locking Adhesive (High Strength) (not furnished w/travel stop) (1052 Size 70 only)

Adjustable Down Travel Stop (figure 17)

Key	Description
54	Hex Nut 1051 Size 40 (1 req'd) Size 60 (2 req'd) 1052 Size 40 (1 req'd) Sizes 60 & 70 (2 req'd)
63	Flange Nut (Sizes 40 & 70)
133	Travel Stop Stem
134	Washer, Plain
139*	O-Ring
141	Cap Screw, Hex hd Size 40 (6 req'd) Size 60 (8 req'd) Size 70 (12 req'd)
142	Travel Stop Body
187	Travel Stop Cap
189	Hex Nut, Jam Sizes 40 & 60 (1 req'd) Size 70 (2 req'd)
241	Lithium Grease (not furnished w/travel stop)

Figure 16. Adjustable Up Travel Stops

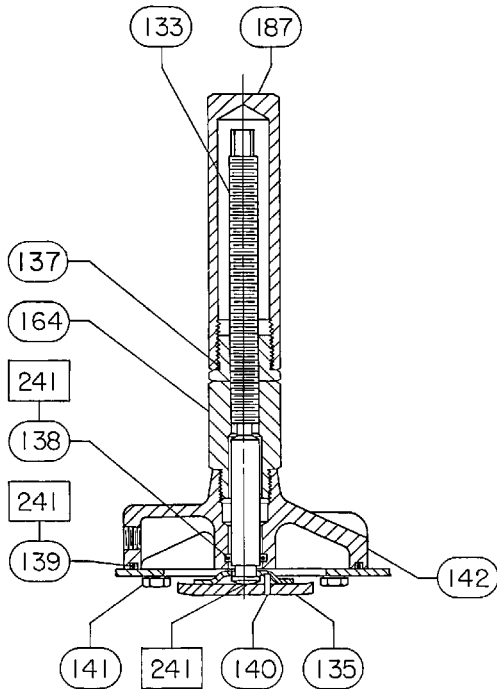

28A1207-B

□ APPLY LUB

**ADJUSTABLE UP TRAVEL STOP FOR
SIZE 30 AND 40 ACTUATORS**

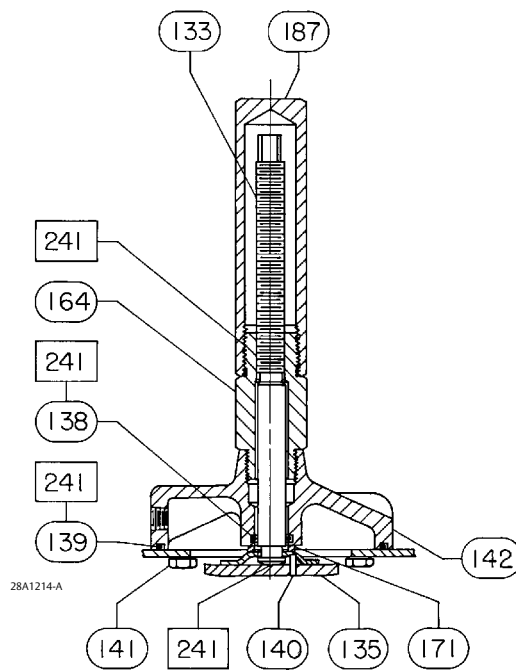

28A1214-A

□ APPLY LUB

**ADJUSTABLE UP TRAVEL STOP FOR
SIZE 60 ACTUATORS**

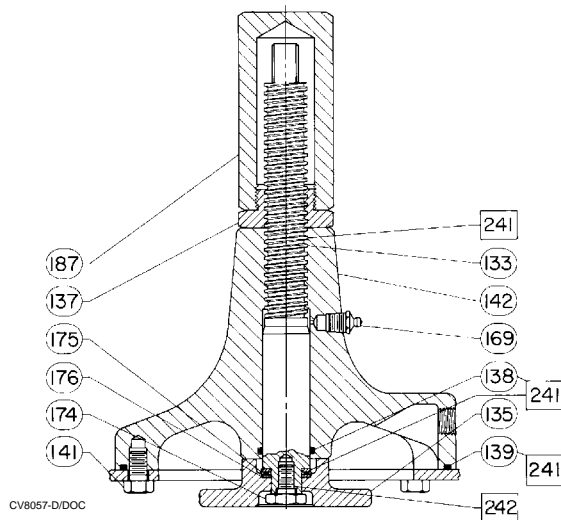

CV8057-D/DOC

□ APPLY LUB / SEALANT

**ADJUSTABLE UP TRAVEL STOP FOR SIZE 70
1052 ACTUATORS**

Figure 17. Adjustable Down Travel Stop

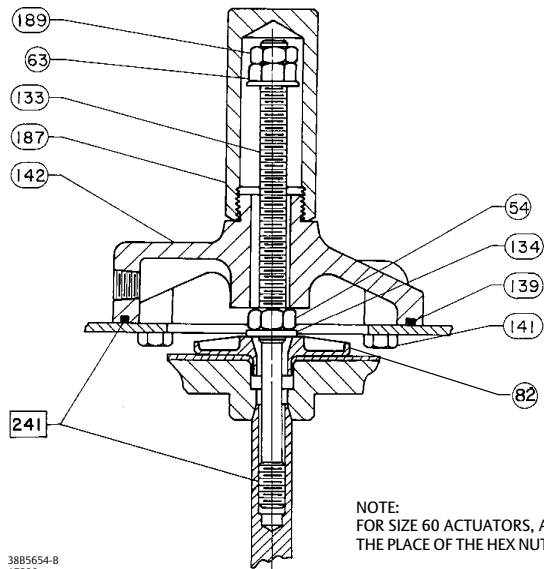

NOTE:
FOR SIZE 60 ACTUATORS, A SECOND HEX NUT (KEY 54) IS USED IN
THE PLACE OF THE HEX NUT (KEY 63)

38B5654-B
A7238

Neither Emerson, Emerson Automation Solutions, nor any of their affiliated entities assumes responsibility for the selection, use or maintenance of any product. Responsibility for proper selection, use, and maintenance of any product remains solely with the purchaser and end user.

Fisher, FISHTAIL, and TopWorx are marks owned by one of the companies in the Emerson Automation Solutions business unit of Emerson Electric Co. Emerson Automation Solutions, Emerson, and the Emerson logo are trademarks and service marks of Emerson Electric Co. All other marks are the property of their respective owners.

The contents of this publication are presented for informational purposes only, and while every effort has been made to ensure their accuracy, they are not to be construed as warranties or guarantees, express or implied, regarding the products or services described herein or their use or applicability. All sales are governed by our terms and conditions, which are available upon request. We reserve the right to modify or improve the designs or specifications of such products at any time without notice.

Emerson Automation Solutions
Marshalltown, Iowa 50158 USA
Sorocaba, 18087 Brazil
Cernay 68700 France
Dubai, United Arab Emirates
Singapore 128461 Singapore

www.Fisher.com

