

# Fisher™ HPS-C and HPT-C Valves

## Contents

Introduction .....	1
Scope of Manual .....	1
Description .....	2
Educational Services .....	2
Specifications .....	3
Installation .....	3
Maintenance .....	5
Packing Maintenance .....	6
Replacing Packing .....	7
Trim Maintenance .....	10
Trim Disassembly .....	10
Valve Plug Maintenance .....	10
Trim Assembly .....	11
Coining Soft Metal-to-Metal Seats .....	12
Parts Ordering .....	12
Parts Kits .....	12
Parts List .....	14

Figure 1. Fisher HP-C Valve with 657 Actuator



X1367

## Introduction

### Scope of Manual

This instruction manual includes installation, maintenance, and parts information for Fisher HPS-C and HPT-C valves. Refer to separate manuals for instructions covering the actuator and accessories.

Do not install, operate, or maintain HPS-C or HPT-C series valves without being fully trained and qualified in valve, actuator, and accessory installation, operation, and maintenance. To avoid personal injury or property damage, it is important to carefully read, understand, and follow all the contents of this manual, including all safety cautions and warnings. If you have any questions about these instructions, contact your [Emerson sales office](#) or Local Business Partner before proceeding.

Table 1. Specifications

**Valve Sizes**

HPS-C: NPS ■ 1 to 3 (CL900 and CL1500) and ■ 1 to 2 (CL2500)

HPT-C: NPS ■ 4, and ■ 6 (CL900 and CL1500)

**End Connection Styles<sup>(1)</sup>**

CL900, 1500, and 2500 raised-face and ring type joint flanges per ASME B16.5

Butt weld end connection per ASME B16.25

PN160 and PN250 flanges per EN1092-1

**Maximum Inlet Pressure<sup>(1)</sup>**

CL900 and 1500—Valves are consistent with pressure-temperature ratings per ASME B16.34

CL2500—Valves are consistent with pressure-temperature ratings per ASME B16.34

**Shutoff Classifications per ANSI/FCI 70-2 and IEC 60534-4**

HPT-C and HPS-C: Metal Seat:

■ Class IV is standard

■ Class V air test is optional (test will be at 50 PSID air)<sup>(2)</sup>

**Material Temperature Capability<sup>(1)</sup>**

HPT-C: -198 to 66°C (-325 to 150°F)

HPS-C: -198 to 316°C (-325 to 600°F)

**Cryogenic Leak Test**

Class C (optional)

**Maximum Actuator Thrust**

See table 2

**Flow Characteristics**

HPT-C and HPS-C: Equal percentage, linear, and modified equal percentage

**Flow Directions**

HPT-C: Normally down for linear and equal percentage trims. Flow up for Whisper Trim

HPS-C: Normally up

**Approximate Weights**

HPS-C:

NPS 1: 47 kg (103 lb)

NPS 2: 81 kg (179 lb)

NPS 3: 147 kg (324 lb)

HPT-C:

NPS 4: 271 kg (598 lb)

NPS 6: 593 kg (1308 lb)

1. Do not exceed the pressure/temperature limits in this manual and any applicable code limitation.

2. Class V shutoff cannot be performed with water. This residual trapped moisture from testing with water can cause valve and trim damages from the ice crystals formed at below freezing service temperature.

## Description

HPS-C has single-port, globe-style control valve with cage-guiding, unbalanced valve plug, and push-down-to-close valve plug action.

HPT-C has single-port, globe-style control valve with cage guiding, balanced valve plug, and push-down-to-close valve plug action.

These valves feature stainless steel construction materials and fabricated extension bonnets.

## Educational Services

For information on available courses for Fisher HPS-C and HPT-C valves, as well as a variety of other products, contact:

Emerson Automation Solutions  
 Educational Services - Registration  
 Phone: 1-641-754-3771 or 1-800-338-8158  
 E-mail: education@emerson.com  
 emerson.com/fishervalvetraining

## Specifications

Table 2. Maximum Allowable Actuator Thrust for Standard Style 3 Bonnet Extension Length

VALVE	VALVE SIZE, NPS	STEM DIAMETER		MAXIMUM ALLOWABLE STEM LOAD FOR S20910 STEM MATERIAL	
		mm	Inches	N	Lb
HPS-C	1	12.7	1/2	15413	3465
		19.1	3/4	45176	10156
	2	12.7	1/2	16458	3700
		19.1	3/4	46738	10507
		25.4	1	95130	21386
	3	19.1	3/4	48873	10987
25.4		1	89956	20223	
HPT-C	4	19.1	3/4	48055	10803
		25.4	1	89956	20223
	6	25.4	1	83382	18745
		31.8	1 1/4	139185	31290

## Installation

### ⚠ WARNING

Always wear protective gloves, clothing, and eyewear when performing any installation operations to avoid personal injury.

Personal injury or equipment damage caused by sudden release of pressure may result if the valve assembly is installed where service conditions could exceed the limits given in table 1 or on the appropriate nameplates. To avoid such injury or damage, provide a relief valve for over-pressure protection as required by government or accepted industry codes and good engineering practices.

Check with your process or safety engineer for any additional measures that must be taken to protect against process media. If installing into an existing application, also refer to the warning at the beginning of the Maintenance section in this instruction manual.

### ⚠ WARNING

When ordered, the valve configuration and construction materials were selected to meet particular pressure, temperature, pressure drop, and controlled fluid conditions. Because some valve body/trim material combinations are limited in their pressure drop and temperature ranges, do not apply any other conditions to the valve without first contacting your [Emerson sales office](#) or Local Business Partner.

### ⚠ WARNING

Some bonnet flanges have a tapped hole that was used to handle the bonnet during manufacture. Do not use this tapped hole to lift the valve assembly or personal injury may result.

1. Before installing the valve, inspect the valve and associated equipment for any damage and any foreign material.
2. Make certain the valve body interior is clean, that pipelines are free of foreign material, and the valve is oriented so that pipeline flow is in the same direction as the arrow on the side of the valve.

3. **Gas Service:** The normal method of mounting for gas service is with the actuator vertical above the valve body. However, the control valve assembly may be installed in any orientation unless limited by seismic criteria. Other positions may result in uneven valve plug and cage wear that could result in improper operation. For mounting assistance, consult your [Emerson sales office](#) or Local Business Partner.

## CAUTION

**To avoid possible damage to the packing, do not allow the installed actuator angle to be so flat as to allow liquid inside the bonnet to come in contact with the packing.**

**Also, if insulation is applied, do not let the insulation run up the extension bonnet. This could cause the packing to freeze and be damaged.**

**Liquid Service:** The preferred method of mounting for liquid service is with the actuator vertical above the valve body. This will allow a vapor layer to form between the liquid and the packing. If there are piping constraints, the actuator can be angled slightly from vertical. However, in no case should the angle be so flat as to allow liquid inside the bonnet to come in contact with the packing. For mounting assistance, consult your Emerson sales office or Local Business Partner.

4. If insulation is applied, make sure it is applied only to the body/bonnet joint. Do not let the insulation run up the extension bonnet.
5. Use accepted piping and welding practices when installing the valve in the line. For flanged valve bodies, use a suitable gasket between the valve body and pipeline flanges.
6. If the actuator and valve are shipped separately, refer to the actuator mounting procedure in the appropriate actuator instruction manual.
7. If the valve body was shipped without packing installed in the packing box, install the packing before putting the valve body into service. Refer to instructions given in the Packing Maintenance procedure.

## ⚠ WARNING

**Personal injury could result from packing leakage. Valve packing was tightened before shipment; however, the packing might require some readjustment to meet specific service conditions.**

Valves with ENVIRO-SEAL™ live-loaded packing will not require this initial readjustment. See the Fisher instruction manual ENVIRO-SEAL Packing System for Sliding-Stem Valves ([D101642X012](#)) for packing instructions. If you wish to convert your present packing arrangement to ENVIRO-SEAL packing, refer to the retrofit kits listed in the parts kit sub-section near the end of this manual.

## Maintenance

Valve parts are subject to normal wear and must be inspected and replaced as necessary. Inspection and maintenance frequency depends on the severity of service conditions. This section includes instructions for packing maintenance and trim maintenance. All maintenance operations may be performed with the valve in the line.

### **⚠ WARNING**

Avoid personal injury or property damage from sudden release of process pressure. Before performing any maintenance operations:

- Do not remove the actuator from the valve while the valve is still pressurized.
- Always wear protective gloves, clothing, and eyewear when performing any maintenance operations to avoid personal injury.
- Disconnect any operating lines providing air pressure, electric power, or a control signal to the actuator. Be sure the actuator cannot suddenly open or close the valve.
- Use bypass valves or completely shut off the process to isolate the valve from process pressure. Relieve process pressure from both sides of the valve. Drain the process media from both sides of the valve.
- Vent the pneumatic actuator loading pressure and relieve any actuator spring precompression.
- Use lock-out procedures to be sure that the above measures stay in effect while you work on the equipment.
- The valve packing box may contain process fluids that are pressurized, *even when the valve has been removed from the pipeline*. Process fluids may spray out under pressure when removing the packing hardware or packing rings, or when loosening the packing box pipe plug.
- Check with your process or safety engineer for any additional measures that must be taken to protect against process media.

### **CAUTION**

Follow instructions carefully to avoid damaging the product surfaces, which could result in damage to the product.

#### **Note**

The HPS-C/HPT-C valves use spiral-wound gaskets which are crushed to provide their seal. A spiral-wound gasket should never be reused. Whenever a gasket seal is disturbed by removing or shifting parts, a new gasket should be installed upon reassembly. This is necessary to ensure a good gasket seal because the used gasket may not seal properly.

## Packing Maintenance

This section covers PTFE V-ring, double PTFE, and graphite packing used in extension bonnets (figure 2).

---

### Note

If the valve has ENVIRO-SEAL live-loaded packing installed, refer to the instruction manual ENVIRO-SEAL Packing System for Sliding Stem Valves ([D101642X012](#)) for packing instructions. Figure 3 shows typical ENVIRO-SEAL arrangements.

---

Standard packing key numbers are shown in figures 2. ENVIRO-SEAL packing key numbers are shown in figure 3. Bonnet and valve key numbers are shown in figures 4 and 5.

For spring-loaded single PTFE V-ring packing, the spring (key 24) maintains a sealing force on the packing. If leakage is noted around the packing follower (key 28), check to be sure the shoulder on the packing follower is touching the bonnet. If the shoulder is not touching the bonnet, tighten the packing flange nuts (key 20), until the shoulder is against the bonnet. If leakage cannot be stopped in this manner, proceed with replacing packing procedures.

If there is undesirable packing leakage with other than spring-loaded packing, first try to limit the leakage and establish a stem seal by tightening the packing flange nuts.

If the packing is relatively new and tight on the stem, and if tightening the packing flange nuts does not stop the leakage, it is possible that the valve stem is worn or nicked so that a seal cannot be made. The surface finish of a new valve stem is critical for making a good packing seal. If the leakage comes from the outside diameter of the packing, it is possible that the leakage is caused by nicks or scratches around the packing box wall. If performing any of the following procedures, inspect the valve stem and packing box wall for nicks and scratches. If leakage continues, replace the packing by following the numbered steps presented in the replacing packing procedure.

## Adding Packing Rings

Key numbers referred to in this procedure are shown in figures 2, 4 and 5 unless otherwise noted.

When using packing with a lantern ring (key 24) it may be possible to add packing rings above the lantern ring as a temporary measure without removing the actuator from the valve body.

1. Isolate the control valve from the line pressure, release pressure from both sides of the valve body, and drain the process media from both sides of the valve. If using a power actuator, also shut-off all pressure lines to the power actuator, release all pressure from the actuator. Use lock-out procedures to be sure that the above measures stay in effect while you work on the equipment.
2. Remove the packing flange nuts (key 20) and lift the packing flange, upper wiper, and packing follower (keys 18, 27, and 28) away from the valve body.
3. It may be possible to dig out the old packing rings on top of the lantern ring, but use care to avoid scratching the valve plug stem or packing box wall. Clean all metal parts to remove particles that would prevent the packing from sealing.
4. Remove the stem connector and slip the packing rings over the end of the valve plug stem.
5. Reassemble the packing follower, upper wiper, packing flange, and packing flange nuts (keys 28, 27, 18, and 20).
6. Reconnect the body-actuator stem connection according to the appropriate actuator instruction manual.
7. Tighten the packing flange nuts only far enough to stop leakage under operating conditions. Check for leakage around the packing follower when the valve is being put into service. Retighten the packing flange nuts as required (see table 3).

Figure 2. Packing Arrangements

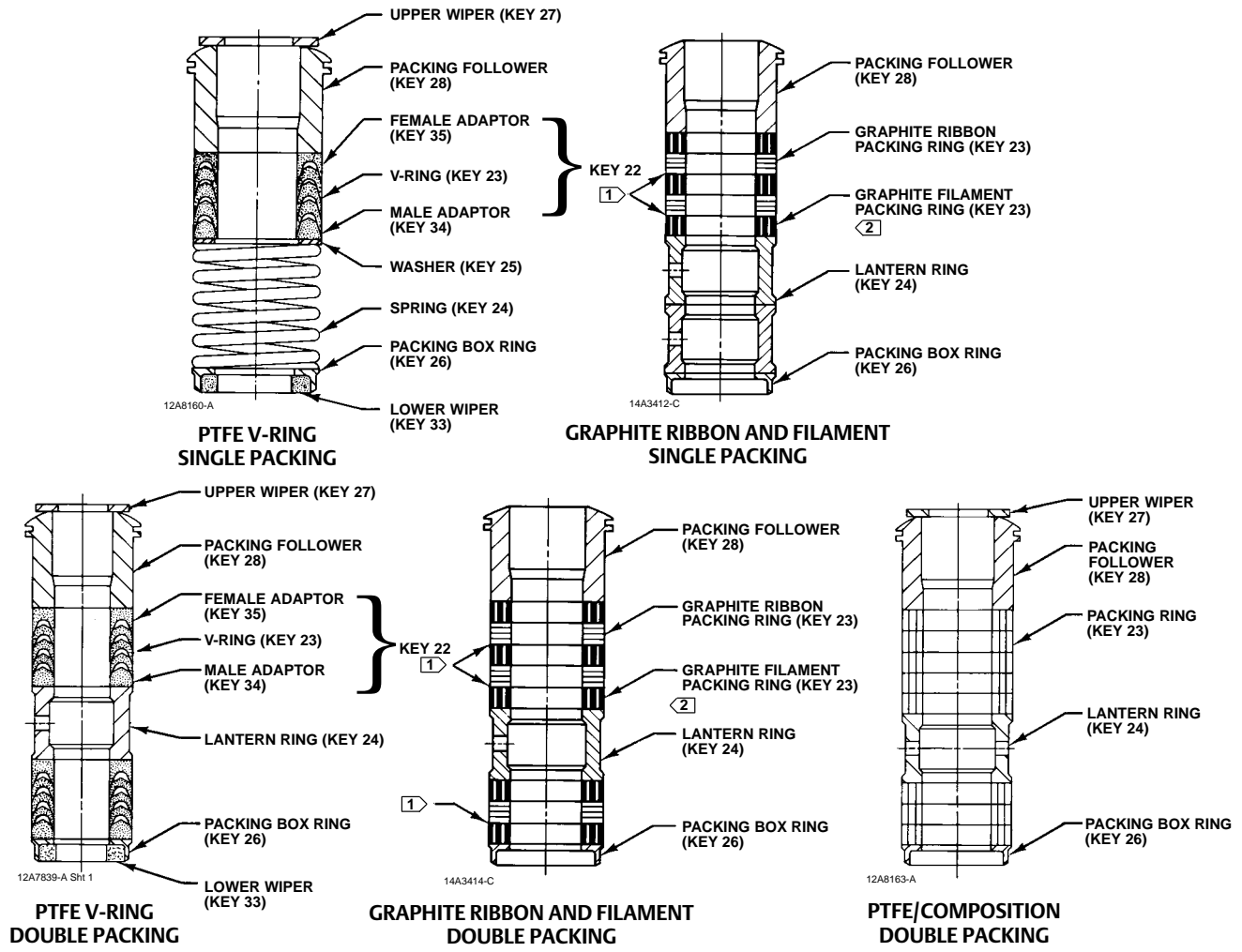

NOTES:  
 1 > 0.102 mm (0.004 INCH) THICK SACRIFICIAL ZINC WASHERS. USE ONLY ONE BELOW EACH GRAPHITE RIBBON RING.  
 2 > HAS THE APPEARANCE OF A WOVEN OR BRAIDED RING.

C0747-1

## Replacing Packing

### **⚠ WARNING**

Refer to the warning at the beginning of the Maintenance section in this instruction manual.

Key numbers and sequence of assembly of packing parts are shown in figures 2. Bonnet and valve key number locations are shown in figures 4 and 5, unless otherwise noted.

1. Isolate the control valve from the line pressure, release pressure from both sides of the valve body, and drain the process media from both sides of the valve. If using a power actuator, also shut-off all pressure lines to the power actuator, release all pressure from the actuator. Use lock-out procedures to be sure that the above measures stay in effect while you work on the equipment. Observe the warnings at the start of the Maintenance section.
2. Disconnect the operating lines from the actuator and any leak-off piping from the bonnet. Disconnect the stem connector and remove the actuator from the valve by unscrewing the yoke locknut (key 32).

- Loosen the packing flange nuts (key 20) so that the packing is not tight on the valve stem. Remove any travel indicator parts and stem locknuts from the valve stem threads.

### ⚠ WARNING

- To avoid personal injury or property damage caused by uncontrolled movement of the bonnet, loosen the bonnet by following the instructions in the next steps.

**Do not remove a stuck bonnet by pulling on it with equipment that can stretch or store energy in any other manner. The sudden release of stored energy can cause uncontrolled movement of the bonnet. If the cage sticks to the bonnet, proceed carefully with bonnet removal and support the cage so that it will not fall unexpectedly from the bonnet.**

- When lifting bonnet, be sure the plug and stem assembly (key 4, 5) and cage (key 2 ) remain in the valve body. This avoids damage to the seating surfaces as a result of the assembly dropping from the bonnet after being lifted part way out. The parts are also easier to handle separately.

### ⚠ WARNING

**To avoid possible personal injury, review your process shutdown procedures to be sure process pressure is not applied to the valve for the following procedure.**

- Hex nuts (key 13) attach the bonnet to the valve body (key 1). Loosen these nuts or cap screws approximately 3 mm (1/8 inch). Then, loosen the body-to-bonnet joint by either rocking the bonnet or prying between the bonnet and valve body. Work with a prying tool around the bonnet until the bonnet loosens.
  - If fluid leaks from the joint, it may indicate that process pressure is applied to the valve. Review your process shutdown procedures, and be sure process pressure is not applied to the valve.
  - If no fluid leaks from the joint, proceed to the next step.
- Unscrew the hex nuts (key 13) and carefully lift the bonnet off the valve stem. If the valve plug and stem assembly starts to lift with the bonnet, use a brass or lead hammer on the end of the stem and tap it back down. Set the bonnet on a cardboard or wooden surface to prevent damage to the bonnet gasket surface.

Table 3. Recommended Torque for Packing Flange Nuts

STEM DIAMETER		PRESSURE RATING <sup>(1)</sup>	TORQUE			
mm	Inches		N•m		lbf•ft	
			Min	Max	Min	Max
12.7	1/2	CL900	12	18	9	13
12.7	1/2	CL1500	15	22	11	16
12.7	1/2	CL2500	18	24	13	18
19.1	3/4	CL900	27	41	20	30
19.1	3/4	CL1500	34	50	25	37
19.1	3/4	CL2500	41	61	30	45
25.4	1	CL900	42	62	31	46
25.4	1	CL1500	52	77	38	57
25.4	1	CL2500	61	91	45	67
31.8	1-1/4	CL900	56	83	41	61
31.8	1-1/4	CL1500	68	102	50	75

1. For intermediate class ratings, use the same torque as the next lower standard class.

- If it is necessary to remove and inspect the valve trim, refer to the following Trim Maintenance section.
- Remove the bonnet gasket (key 10) and cover the opening in the valve to protect the gasket surface and prevent foreign material from getting into the valve body cavity.



- Remove the packing flange nuts, packing flange, upper wiper, and packing follower (keys 20, 18, 27, and 28). Carefully push out all the remaining packing parts from the valve side of the bonnet using a rounded rod or other tool that will not scratch the packing box wall. Clean the packing box and metal packing parts.

Table 4. Torque for Body-to-Bonnet Bolting Using Anti-Seize Lubricant<sup>(1)</sup>

VALVE TYPE	VALVE RATING	VALVE SIZE, NPS	TORQUE	
			N•m	lbf•ft
			B8M, S20910 Studs	
HPS-C	CL900 & CL1500	1	260	190
		2	370	275
		3	710	525
HPT-C		4	940	695
		6	1650	1220
HPS-C		CL2500	1	370
	2		710	525

1. For other materials, contact your [Emerson sales office](#) or Local Business Partner for torques.

- Inspect the valve stem threads and packing box surfaces for any sharp edges which might cut the packing. Scratches or burrs in the packing box surfaces could cause leakage or damage to the new packing. If the surface condition cannot be improved by light sanding, replace the damaged parts.
- If necessary, go to the Trim Maintenance procedures to remove, inspect or replace trim parts. Return to this section when installing the bonnet on the valve body.

### Installing the Bonnet

- Remove the covering protecting the valve body cavity and install a new bonnet gasket (key 10), making sure the gasket seating surfaces are clean and smooth. Then slide the bonnet over the stem and onto the stud bolts (key 12).

#### Note

Stud(s) and nut(s) should be installed such that the manufacturer's trademark and material grade marking is visible, allowing easy comparison to the materials selected and documented in the Emerson/Fisher serial card provided with this product.

### **⚠ WARNING**

**Personal injury or damage to equipment could occur if improper stud and nut materials or parts are used. Do not operate or assemble this product with stud(s) and nut(s) that are not approved by Emerson/Fisher engineering and/or listed on the serial card provided with this product. Use of unapproved materials and parts could lead to stresses exceeding the design or code limits intended for this particular service. Install studs with the material grade and manufacturer's identification mark visible. Contact your [Emerson sales office](#) or Local Business Partner immediately if a discrepancy between actual parts and approved parts is suspected.**

- Lubricate the stud threads and the faces of the hex nuts (key 13) with anti-seize lubricant (not necessary if new factory pre lubricated hex nuts are used). Replace the hex nuts and tighten them finger-tight. Stroke the valve several times to center the trim.  
  
Torque the nuts in a crisscross pattern to no more than 1/4 of the nominal torque value specified in table 4. When all nuts are tightened to that torque value, increase the torque by 1/4 of the specified nominal torque and repeat the crisscross pattern. Repeat this procedure until all nuts are tightened to the specified nominal value. Apply the final torque value again and, if any nut still turns, tighten every nut again
- Install new packing and the metal packing box parts according to the appropriate arrangement in figures 2. Place a smooth-edged pipe over the valve stem and gently tap each soft packing part into the packing box.
- Slide the packing follower, upper wiper, and packing flange (keys 28, 27, and 18) into position. Lubricate the packing flange studs (key 19) and faces of the packing flange nuts (key 20). Install the packing flange nuts.

5. Tightening packing flange nuts (key 20):
  - For spring-loaded PTFE V-ring packing, tighten the packing flange nuts until the shoulder on the packing follower (key 28) contacts the bonnet.
  - For graphite packing, tighten the packing flange nuts to the maximum recommended torque shown in table 3. Then, loosen the packing flange nuts, and retighten them to the recommended minimum torque shown in table 3.
  - For other packing types, tighten the packing flange nuts alternately in small equal increments until one of the nuts reaches the minimum recommended torque shown in table 3. Then, tighten the remaining nut until the packing flange is level and at a 90 degree angle to the valve stem.
  - For ENVIRO-SEAL live-loaded packing; refer to the Fisher instruction manual ENVIRO-SEAL Packing System for Sliding-Stem Valves ([D101642X012](#)).
6. Mount the actuator on the valve assembly and reconnect the actuator and valve stem according to the procedure in the appropriate actuator instruction manual.

## Trim Maintenance

### **⚠ WARNING**

Refer to the **WARNING** at the beginning of the Maintenance section in this instruction manual.

This procedure describes how the valve trim can be completely disassembled. When inspection or repairs are required, perform only those steps necessary to accomplish the task. Observe the warning at the start of the Maintenance section.

Key number locations are shown in figures 4 and 5 unless otherwise noted.

### Trim Disassembly

1. Remove the actuator and the bonnet according to steps 1 through 6 of the Replacing Packing procedures in the Maintenance section.

### **⚠ WARNING**

**To avoid personal injury due to leaking fluids, avoid damaging gasket sealing surfaces.**

**The surface finish of the valve stem (key 5) is critical for making a good packing seal.**

**The inside surface of the cage (key 2) is critical for tight shutoff and smooth operation of the valve plug.**

**The seating surfaces of the valve plug (key 4) and seat ring (key 6) are critical for proper shutoff.**

**Protect these surfaces accordingly.**

2. Lift the valve stem and attached valve plug out of the valve body. If the valve plug is to be reused, tape or otherwise protect the valve plug stem and the valve plug seating surface to prevent scratches.
3. Lift out the cage (key 2) and the bonnet gasket (key 10).
4. Remove the seat ring (key 3) and seat ring gasket (key 11).
5. Clean, inspect, and if necessary obtain replacement parts.

## Valve Plug Maintenance

### **CAUTION**

**To avoid the valve plug seal ring (key 7) not sealing properly and affecting valve performance, be careful not to scratch the surfaces of the ring groove on the valve plug or any of the surfaces of the replacement ring.**

1. With the valve plug (key 4) removed, according to the disassembly portion of the Trim Maintenance procedure, proceed as follows: For HPS-C valves, proceed to step 5:
2. For HPT-C valves, the spring-loaded seal ring may be removed by first working the retaining ring (key 9) off with a screwdriver. Then carefully slide the metal backup ring (key 8) and seal ring (key 7) off the valve plug (key 4).
3. A spring-loaded seal ring must be installed so that its open side faces toward the valve stem, or toward the seat of the plug depending on flow direction. To install a spring-loaded seal ring, slide the seal ring (key 7) onto the valve plug followed by the metal backup ring (key 8).
4. Then install the retaining ring (key 9) by inserting one end in the groove and, while turning the plug, press the ring into the groove. Again, be careful not to scratch any surfaces of the ring or plug.

**CAUTION**

To avoid weakening the stem that may cause failure in service, never reuse an old stem with a new valve plug. Using an old stem with a new plug requires drilling a new pin hole in the stem, which will weaken the stem. However, a used valve plug may be reused with a new stem.

5. To replace the valve stem (key 5), drive or drill out the pin (key 6). Unscrew the valve plug from the stem.
6. Screw the new stem into the valve plug. Tighten to the torque value given in table 5. Also, use this table to select the proper drill size. Drill through the stem using the hole in the valve plug as a guide. Remove any chips or burrs and drive in a new pin to lock the assembly.

**Trim Assembly**

Key number locations are shown in figure 4 and 5, unless otherwise noted.

1. Install the seat ring gasket (key 11), and seat ring (key 3).
2. Install the cage (key 2). Any rotational orientation of the cage with respect to the valve body is acceptable.
3. Lower the valve plug (key 4) and stem assembly into the cage. Make sure the seal ring (key 7) is evenly engaged in the entrance chamfer at the top of the cage (key 2) to avoid damaging the ring.
4. Place the gaskets (keys 10) on top of the cage.
5. Mount the bonnet on the valve body and complete assembly using the Replacing Packing procedures in the Maintenance section. Torque guidelines for body-to-bonnet bolting are shown in table 4.
6. If the valve has soft metal-to-metal seats, refer to the Coining Soft Metal-to-Metal Seats section, below.

Table 5. Valve Stem Connection Torque and Drill Size for Pin Hole

VALVE SIZE, NPS	VALVE STEM DIAMETER		DESIGN	VALVE STEM CONNECTION TORQUE (MINIMUM-MAXIMUM)		DRILL SIZE FOR PIN	
	mm	Inches		N•m	Lbf•ft	Inches	
1	12.7	1/2	HPS-C	81 - 115	60 - 85	1/8	
	19.1	3/4		237 - 339	175 - 250	3/16	
2	12.7	1/2		81 - 115	60 - 85	1/8	
	19.1	3/4		237 - 339	175 - 250	3/16	
	25.4	1		420 - 481	310 - 355	1/4	
3	19.1	3/4		237 - 339	175 - 250	3/16	
	25.4	1		420 - 481	310 - 355	1/4	
4	19.1	3/4		HPT-C	237 - 339	175 - 250	3/16
	25.4	1			420 - 481	310 - 355	1/4
6	25.4	1			420 - 481	310 - 355	1/4
	31.8	1-1/4			827 - 908	610 - 670	1/4

## Coining Soft Metal-to-Metal Seats

Soft metal-to-metal seat constructions consist of a valve plug with hardfaced CoCr-A seat and a non-hardfaced S31600 seat ring. For optimum shutoff performance of these constructions, coin seats by stroking the valve plug into the seat ring at least three times with maximum actuator force.

### CAUTION

To avoid possible product damage which may affect performance, do not lap soft metal-to-metal seats.

## Parts Ordering

Each body-bonnet assembly is assigned a serial number which can be found on the valve. This same number also appears on the actuator nameplate when the valve is shipped from the factory as part of a control valve assembly.

Refer to the serial number when contacting your [Emerson sales office](#) or Local Business Partner for technical assistance. When ordering replacement parts, refer to the serial number and to the eleven-character part number for each part required from the following parts kit or parts list information.

### ▲ WARNING

Use only genuine Fisher replacement parts. Components that are not supplied by Emerson Automation Solutions should not, under any circumstances, be used in any Fisher valve, because they may void your warranty, might adversely affect the performance of the valve, and could cause personal injury and property damage.

## Parts Kits

### Packing Kits

#### Standard Packing Repair Kits (Non Live-Loaded)

Stem Diameter, mm (Inches) Yoke Boss Diameter, mm (Inches)	12.7 (1/2) 71 (2-13/16)	19.1 (3/4) 90 (3-9/16)	25.4 (1) 127 (5)	31.8 (1-1/4) 127 (5, 5H)
PTFE (Contains keys 22, 24, 25, 26, 27)	RPACKX00022	RPACKX00032	RPACKX00342	RPACKX00352
Double PTFE (Contains keys 22, 24, 26, 27)	RPACKX00052	RPACKX00062	RPACKX00362	RPACKX00372
Single Graphite Ribbon/Filament (Contains keys 23 [ribbon ring], 23 [filament ring], 24, and 26)	RPACKX00112	RPACKX00122	----	---
Single Graphite Ribbon/Filament (Contains keys 23 [ribbon ring], 23 [filament ring], and 26)	---	---	RPACKX00532	RPACKX00542
Single Graphite Ribbon/Filament (Contains keys 23 [ribbon ring], 23 [filament ring])	RPACKX00142	RPACKX00152	----	---

### ENVIRO-SEAL Packing Retrofit Kits

Retrofit kits include parts to convert valves with existing standard bonnets to the ENVIRO-SEAL packing box construction. Refer to figure 3 for key numbers for PTFE and Graphite ULF packing.

Stems and packing box constructions that do not meet Fisher stem finish specifications, dimensional tolerances, and design specifications, may adversely alter the performance of this packing kit.

ENVIRO-SEAL Packing Retrofit Kits

Stem Diameter, mm (Inches) Yoke Boss Diameter, mm (Inches)	12.7 (1/2) 71 (2-13/16)	19.1 (3/4) 90 (3-9/16)	25.4 (1) 127 (5)	31.8 (1-1/4) 127 (5, 5H)
Double PTFE (Contains keys 200, 201, 211, 212, 214, 215, 216, 217, 218, tag, cable tie)	RPACKXRT022	RPACKXRT032	RPACKXRT042	RPACKXRT052
Graphite ULF (Contains keys 200, 201, 207, 208, 209, 210, 211, 212, 214, 217, tag, cable tie)	RPACKXRT272	RPACKXRT282	RPACKXRT292	RPACKXRT302
Duplex (Contains keys 200, 201, 207, 209, 211, 212, 214, 215, 216, 217, tag, cable tie)	RPACKXRT222	RPACKXRT232	RPACKXRT242	RPACKXRT252

ENVIRO-SEAL Packing Repair Kits

Repair kits include parts to replace the “soft” packing materials in valves that already have ENVIRO-SEAL packing arrangements installed or in valves that have been upgraded with ENVIRO-SEAL retrofit kits. Refer to figure 3 for key numbers for PTFE and Graphite ULF packing.

Stems and packing box constructions that do not meet Fisher stem finish specifications, dimensional tolerances, and design specifications, may adversely alter the performance of this packing kit.

ENVIRO-SEAL Packing Repair Kits

Stem Diameter, mm (Inches) Yoke Boss Diameter, mm (Inches)	12.7 (1/2) 71 (2-13/16)	19.1 (3/4) 90 (3-9/16)	25.4 (1) 127 (5)	31.8 (1-1/4) 127 (5, 5H)
Double PTFE (Contains keys 214, 215, & 218)	RPACKX00202	RPACKX00212	RPACKX00222	RPACKX00232
Graphite ULF (Contains keys 207, 208, 209, 210, and 214)	RPACKX00602	RPACKX00612	RPACKX00622	RPACKX00632
Duplex (Contains keys 207, 209, 214, and 215)	RPACKX00302	RPACKX00312	RPACKX00322	RPACKX00332

Figure 3. Enviro-seal Packing

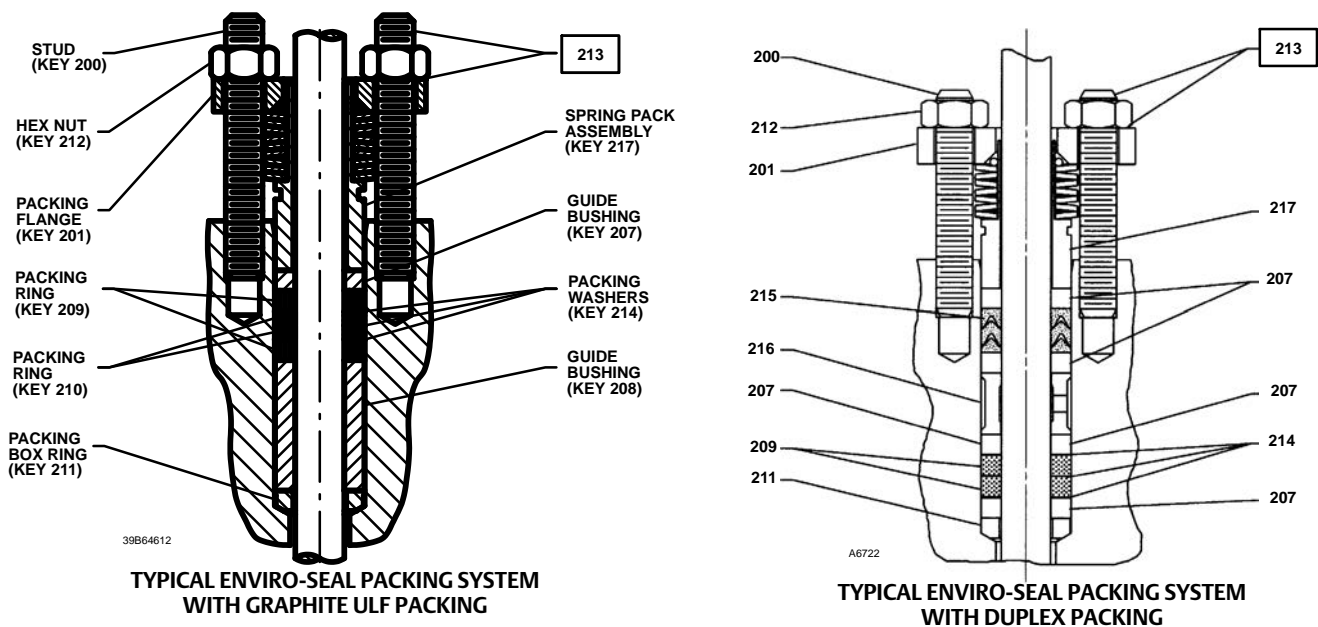

Gasket Kit

VALVE RATING	VALVE SIZE, NPS	MATERIAL	
		N06600/Graphite	N07750/Graphite
HPS-C CL1500	1	12B7100X012	12B7100X022
	2	12B7100X032	12B7100X042
	3	12B7100X052	12B7100X062
HPT-C CL1500	4	12B7100X082	---
	6	12B7100X112	---
HPS-C CL2500	1	12B7100X152	12B7100X122
	2	12B7100X162	12B7100X132

Parts List

Numerous available combinations of valve parts make selection of some parts difficult; when ordering valve parts, provide the valve serial number with the order, permitting proper selection of replacement parts to be made at the factory.

Note

Contact your [Emerson sales office](#) or Local Business Partner for Part Ordering information.

Key	Description
1	Valve Body If you need a valve body as a replacement part, order by valve size, serial number, and desired material.
2*	Cage
3*	Seat Ring
4*	Valve Plug
5*	Valve Stem
6*	Pin
7*	Seal Ring, R30003/UHMWPE
8*	Back Up Ring
9*	Retaining Ring (for HPT-C only)
10*	Bonnet Gasket

Key	Description
11*	Seat Ring Gasket
12	Stud
13	Hex Nut
14	Anti-Seize Lubricant
15	Nameplate
16	Wire
17	Bonnet If you need a bonnet as a replacement part, order by valve size and stem diameter, serial number, and desired material.
18	Packing Flange
19	Stud Bolt
20	Hex Nut
22*	Packing Set
23*	Packing Ring
24	Spring or Lantern Ring
25	Washer, Special
26*	Packing Box Ring
27*	Upper Wiper
28	Follower
29	Stud Bolt
30	Hex Nut
32	Yoke Locknut
36	Baffle
37	Retaining Ring
38	Drive Screw
41	Flow Arrow

See Parts Kits  
See Parts Kits  
See Parts Kits  
See Parts Kits  
See Parts Kits

\*Recommended spare parts

Figure 4. Fisher HPS-C Valve Assembly

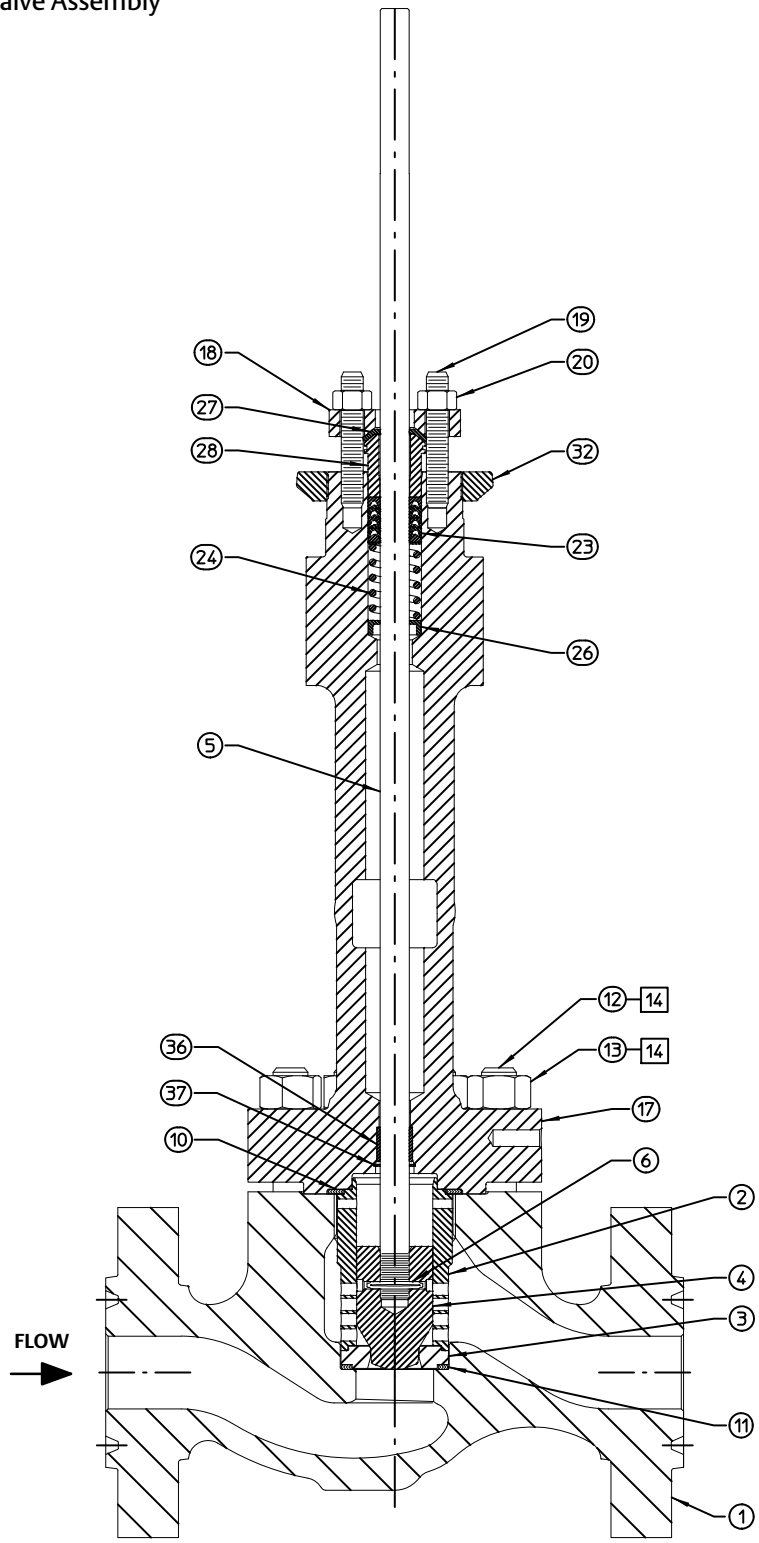

GE87219

Figure 5. Fisher HPT-C Valve Assembly

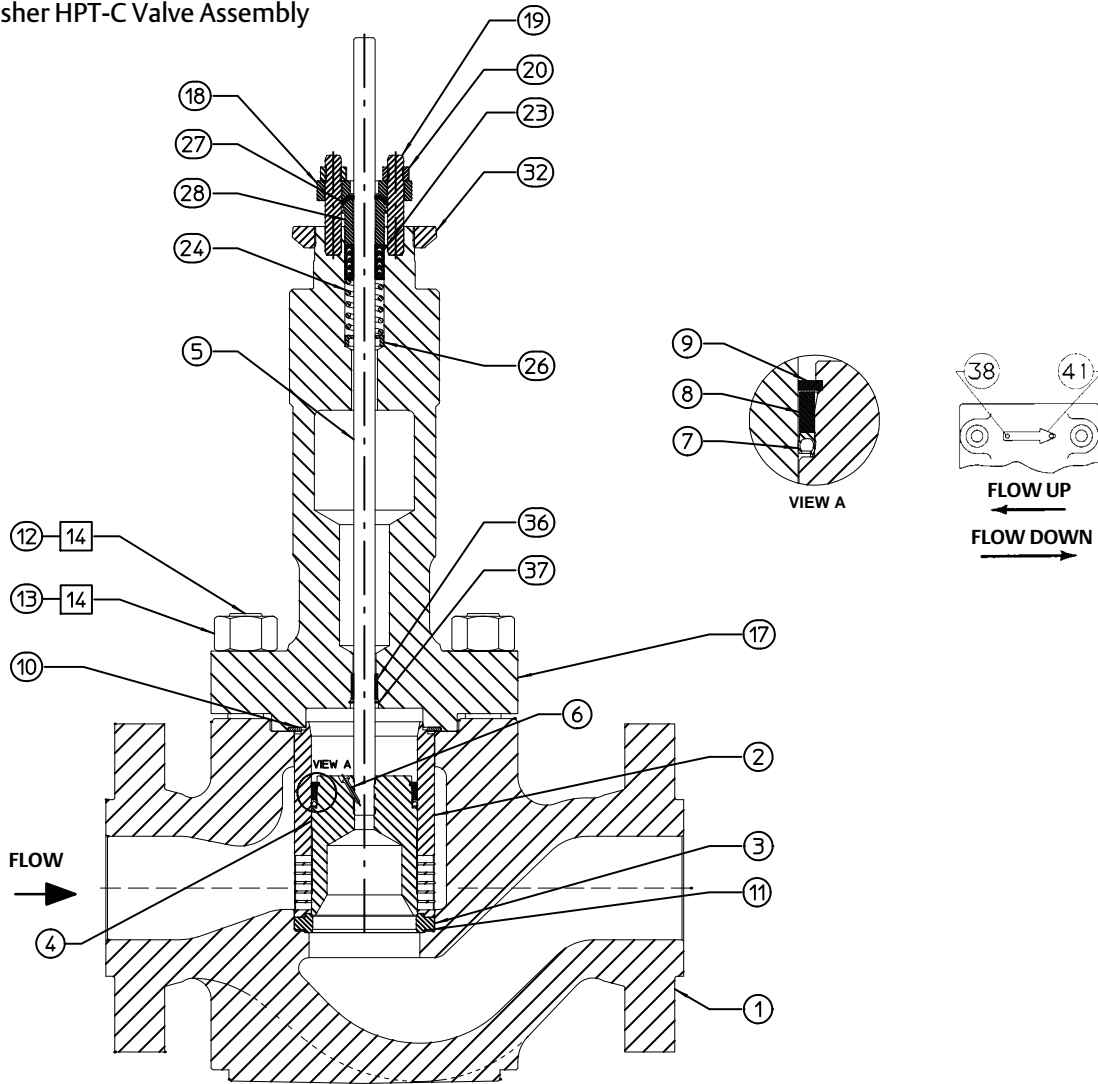

CE87206

Neither Emerson, Emerson Automation Solutions, nor any of their affiliated entities assumes responsibility for the selection, use or maintenance of any product. Responsibility for proper selection, use, and maintenance of any product remains solely with the purchaser and end user.

Fisher and ENVIRO-SEAL are marks owned by one of the companies in the Emerson Automation Solutions business unit of Emerson Electric Co. Emerson Automation Solutions, Emerson, and the Emerson logo are trademarks and service marks of Emerson Electric Co. All other marks are the property of their respective owners.

The contents of this publication are presented for informational purposes only, and while every effort has been made to ensure their accuracy, they are not to be construed as warranties or guarantees, express or implied, regarding the products or services described herein or their use or applicability. All sales are governed by our terms and conditions, which are available upon request. We reserve the right to modify or improve the designs or specifications of such products at any time without notice.

Emerson Automation Solutions  
 Marshalltown, Iowa 50158 USA  
 Sorocaba, 18087 Brazil  
 Cernay, 68700 France  
 Dubai, United Arab Emirates  
 Singapore 128461 Singapore

[www.Fisher.com](http://www.Fisher.com)

