

Montagehinweis | Notes on assembly | Indication de montage

Drehzylinder mit Drehwinkeleinstellung  
Rotary cylinder with rotation angle setting  
Vérin rotatif avec réglage précis de l'angle de rotation

## TRR

1829930147/06.2015, Replaces: 10.2003, DE/EN/FR

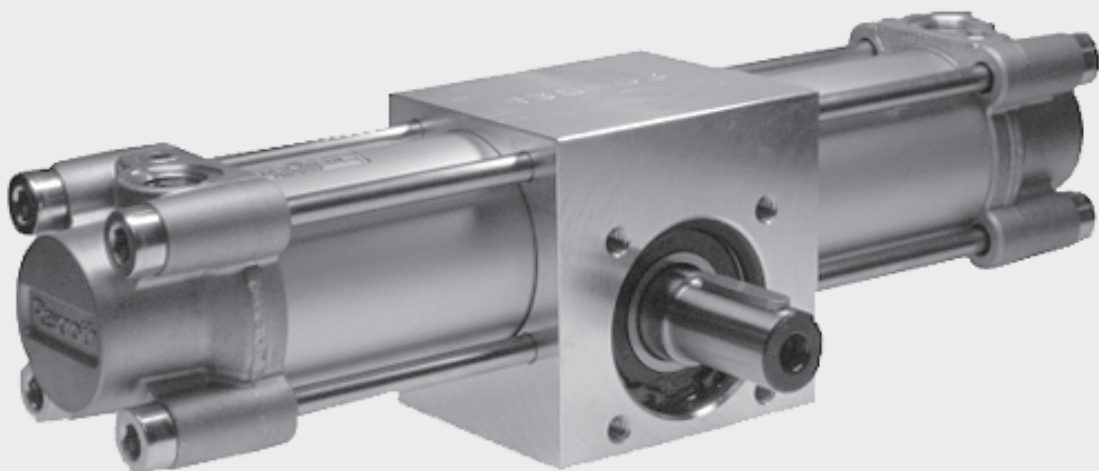

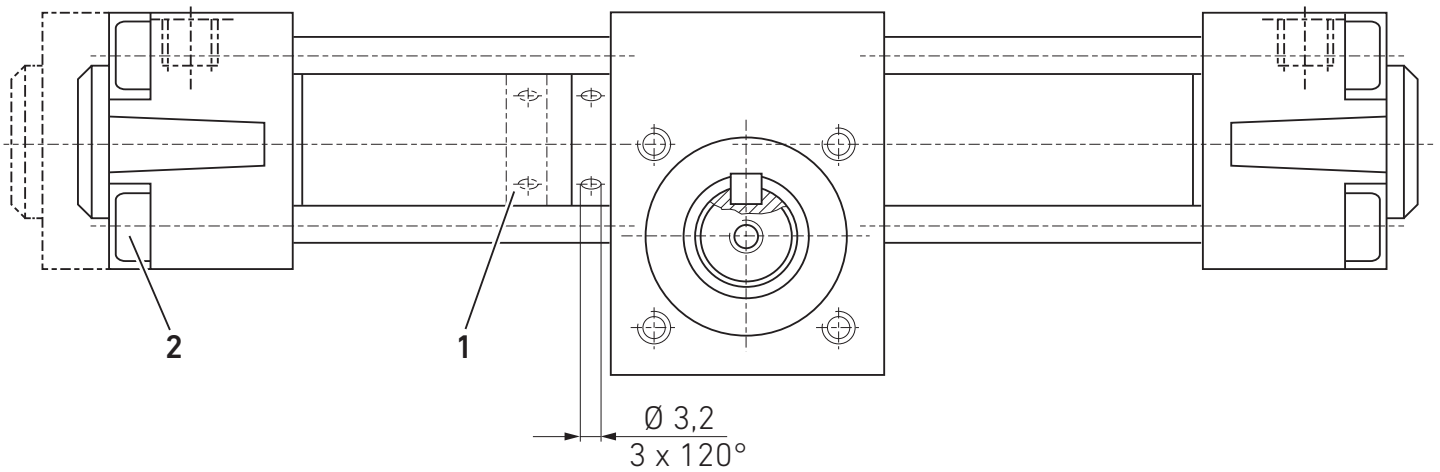

### Drehzylinder | rotary cylinder | vérin rotatif

1822932227 ... 229

1822933227 ... 229

1822934227 ... 229

1822935227 ... 229

1

**DE** Drehwinkleinstellung durch Verdrehen des Verstellringes (1).  
Dabei müssen die Halsmutter (2) der Zuganker gelöst und mit dem Moment  $M_a$  wieder angezogen werden.

Der Drehzylinder ist im Auslieferungszustand auf den max. Drehwinkel eingestellt (Verstellring herausgedreht).

**EN** Rotation angle is set by turning the adjusting ring (1).  
In so doing, the tie rod nuts (2) have to be released and re-tightened with torque  $M_a$ .

The rotary cylinder as delivered is set to the max. rotation angle (adjusting ring unscrewed).

**FR** Réglage de l'angle de rotation en tournant la bague de réglage (1).  
Les écrous à collet du tirant (2) doivent alors être desserrés et être à nouveau serrés avec le couple  $M_a$ .

Le vérin rotatif est livré réglé sur l'angle de rotation maximum (bague de réglage desserrée à fond).

Zylinderdurchmesser  
Cylinder diameter  
Diamètre du vérin  
[mm]

Anzugsmoment  $M_a$  der Halsmutter (2)  
für Antriebe mit Enddrehwinkeljustierung  
Torque  $M_a$  of the tie rod nut (2)  
for rotary actuator with rotation angle setting  
Couple de serrage  $M_a$  de l'écrou à tirant (2)  
pour vérin rotatif avec réglage de l'angle de rotation  
[Nm]

50

10-12

63

80

30-35

100



**AVENTICS GmbH**

Ulmer Straße 4  
30880 Laatzen  
Phone +49 (0) 5 11-21 36-0  
Fax: +49 (0) 511-21 36-2 69  
www.aventics.com  
info@aventics.com



The data specified above only serve to describe the product. No statements concerning a certain condition or suitability for a certain application can be derived from our information. The given information does not release the user from the obligation of own judgement and verification. It must be remembered that our products are subject to a natural process of wear and aging.

An example configuration is depicted on the title page. The delivered product may thus vary from that in the illustration.

Translation of the original operating instructions. The original operating instructions were created in the German language.

1829930147-BDL-001-AB/06.2015  
Subject to modifications. © All rights reserved by AVENTICS GmbH, even and especially in cases of proprietary rights applications. It may not be reproduced or given to third parties without its consent.