

Rosemount™ 5081FG

Two-Wire In-Situ Oxygen Analyzer (550 °C to 1600 °C)

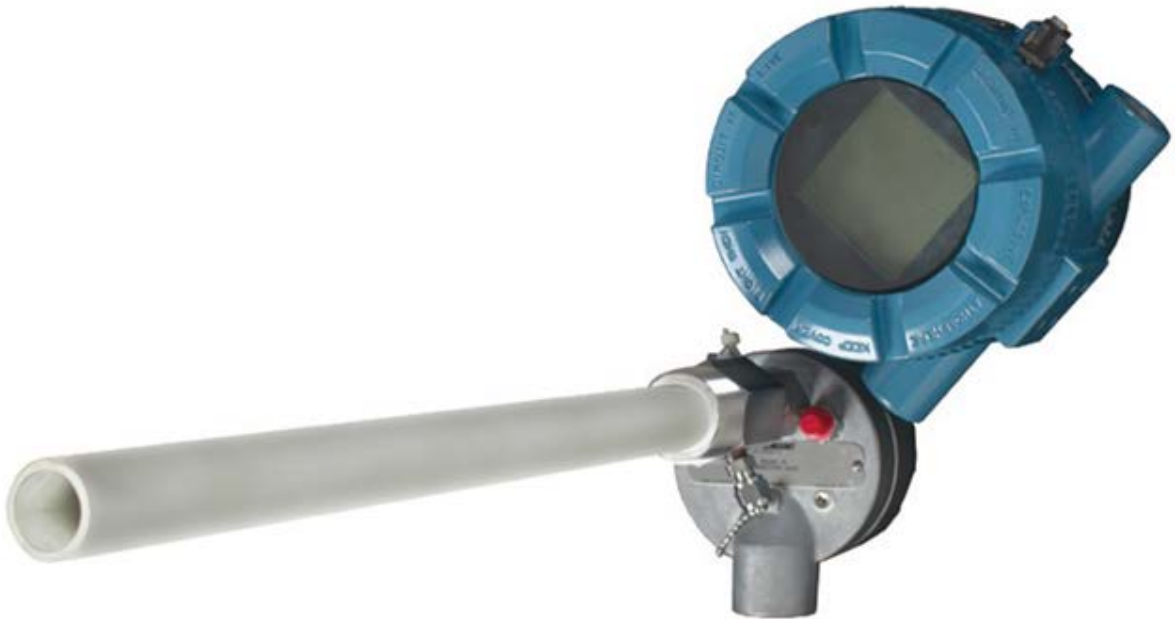

Table of Contents

SECTION i Introduction	Preface	iv
	Definitions	iv
	Symbols	iv
	Technical Support Hotline:	iv
SECTION 1 Description and Specifications	Component Checklist	1-1
	System Overview	1-3
	Scope	1-3
	System Description	1-3
	System Configuration	1-4
	System Features	1-4
	Handling the Analyzer	1-6
	System Considerations	1-6
	Specifications	1-7
SECTION 2 Installation	Pre-Installation	2-2
	Inspect	2-2
	Packing List	2-2
	Mechanical Installation	2-2
	Locating Oxygen Probe	2-2
	Installing Oxygen Probe	2-4
	Locating Rosemount 5081 Transmitter	2-7
	Installing Rosemount 5081 Transmitter	2-8
	Electrical Installation	2-11
	General	2-11
	Oxygen Probe Signal Connections	2-12
	Rosemount 5081 Transmitter 4-20 mA and Signal Connections	2-13
	Pneumatic Installation	2-14
	General	2-14
	Reference Air Package	2-14
Instrument Air (Reference Air)	2-14	
Calibration Gas	2-15	
SECTION 3 Startup and Operation	General	3-1
	Power Up	3-1
	Establishing Proper Calibration Gas Flow Rate	3-3
	Operation	3-4
	Overview	3-4
	Display	3-4
	Menu Tree	3-4
	Navigation	3-6
	Program Menu	3-7
	Operator Adjustable Parameters	3-7
	Code	3-8
	Display Code	3-9
Fault Val	3-9	
Upper Range Val	3-10	

Cell T Hi	3-10
Reset Max Cell T	3-11
Set O2 Filter Time.....	3-11
Trim 4mA	3-12
Trim 20mA	3-13
Set Hi Bottle O ₂	3-14
Set Lo Bottle O ₂	3-14
Set O ₂ Tracking.....	3-15
Set Code	3-15
Diagnostics Menu	3-16
Show Fault.....	3-16
T/C mV.....	3-17
O ₂ CELL mV	3-17
Cell Impedance.....	3-18
Current Slope.....	3-18
Current Constant	3-19
Previous Slope.....	3-19
Previous Constant	3-20
Max Cell T.....	3-20
SW Ver (SOft).....	3-21
Unit Ser # (SEr).....	3-21
SW Build Number (bLdn).....	3-21
SW Build Date (bd)	3-21
Cal Check Menu.....	3-21
In Manual	3-21
Accept High O ₂	3-22
Accept Low O ₂	3-22
Slope.....	3-23
Constant.....	3-23

**SECTION 4
HART/AMS**

Overview	4-1
Field Communicator Signal Line Connections.....	4-2
Field Communicator PC Connections.....	4-4
Off-Line and On-Line Operations.....	4-4
HART/AMS Menu Tree	4-4
Field Communicator Start Cal Check Method	4-8

**SECTION 5
Troubleshooting**

General	5-1
Probe Life.....	5-1
Fault Indications	5-3
Identifying And Correcting Fault Indications	5-4
Calibration Passes, But Still Reads Incorrectly.....	5-8
Probe Passes	
Calibration, O2 Still	
Reads High	5-8

**SECTION 6
Maintenance and Service**

Overview	6-1
Electronics	
Replacement.....	6-1
Display Board Replacement	6-1
Spare Board Stack Replacement	6-3
Oxygen Probe Replacement.....	6-3

SECTION 7
Replacement Parts

APPENDIX A	Safety Instructions	A-2
Safety Data	Safety Data Sheet for Ceramic Fiber Products	A-3

APPENDIX B	Returning Material	B-1
Return of Material		

Oxygen Analyzers

READ THIS PAGE BEFORE PROCEEDING!

ESSENTIAL INSTRUCTIONS

Emerson designs, manufactures and tests its products to meet many national and international standards. Because these instruments are sophisticated technical products, **you MUST properly install, use, and maintain them** to ensure they continue to operate within their normal specifications. The following instructions **MUST be adhered to** and integrated into your safety program when installing, using, and maintaining Emerson's Rosemount products. Failure to follow the proper instructions may cause any one of the following situations to occur: Loss of life; personal injury; property damage; damage to this instrument; and warranty invalidation.

- **Read all instructions** prior to installing, operating, and servicing the product.
- If you do not understand any of the instructions, **contact your Emerson representative** for clarification.
- **Follow all warnings, cautions, and instructions** marked on and supplied with the product.
- **Inform and educate your personnel in the proper installation, operation, and maintenance of the product.**
- **Install your equipment as specified in the Installation Instructions of the appropriate Instruction Manual and per applicable local and national codes.** Connect all products to the proper electrical and pressure sources.
- To ensure proper performance, **use qualified personnel** to install, operate, update, program, and maintain the product.
- When replacement parts are required, ensure that qualified people use replacement parts specified by Emerson. Unauthorized parts and procedures can affect the product's performance, place the safe operation of your process at risk, **and VOID YOUR WARRANTY.** Look-alike substitutions may result in fire, electrical hazards, or improper operation.
- **Ensure that all equipment doors are closed and protective covers are in place, except when maintenance is being performed by qualified persons, to prevent electrical shock and personal injury.**

The information contained in this document is subject to change without notice.

CAUTION

If a Model 275/375 Universal HART® Communicator is used with this unit, the software within the Model 275/375 may require modification. If a software modification is required, please contact your local Emerson Service Group or National Response Center at 1-800-433-6076 or 1-888-433-6829.

WARNING

Physical access

Unauthorized personnel may potentially cause significant damage to and/or misconfiguration of end users' equipment. This could be intentional or unintentional and needs to be protected against.

Physical security is an important part of any security program and fundamental to protecting your system. Restrict physical access by unauthorized personnel to protect end users' assets. This is true for all systems used within the facility.

Section 1 Introduction

Preface	page i-iv
Definitions	page i-iv
Symbols	page i-iv

PREFACE

The purpose of this manual is to provide information concerning the components, functions, installation and maintenance of the Rosemount 5081FG Two-Wire In-Situ Oxygen Analyzer (550° to 1600°C).

Some sections may describe equipment not used in your configuration. The user should become thoroughly familiar with the operation of this module before operating it. Read this instruction manual completely.

DEFINITIONS

The following definitions apply to WARNINGS, CAUTIONS, and NOTES found throughout this publication.

WARNING

Highlights an operation or maintenance procedure, practice, condition, statement, etc. If not strictly observed, could result in injury, death, or long-term health hazards of personnel.





CAUTION

Highlights an operation or maintenance procedure, practice, condition, statement, etc. If not strictly observed, could result in damage to or destruction of equipment, or loss of effectiveness.

NOTE

Highlights an essential operating procedure, condition, or statement.

SYMBOLS

-  : EARTH (GROUND) TERMINAL
-  : PROTECTIVE CONDUCT OR TERMINAL
-  : RISK OF ELECTRICAL SHOCK
-  : WARNING: REFER TO INSTRUCTION MANUAL

NOTE TO USERS

The number in the lower right corner of each illustration in this publication is a manual illustration number. It is not a part number, and is not related to the illustration in any technical manner.

Rosemount 5081FG

Reference Manual
00809-0100-4882, Rev AB
June 2019

Technical Support Hotline:

For assistance with technical problems, please call the North American Response Center. The Response Center is staffed 24 hours a day, 7 days a week.

Phone: 1-800-654-RSMT (1-800-654-7768)

Emerson may also be reached via the Internet through email and the World Wide Web:

Email: GAS.CSC@emerson.com

Section 1 Description and Specifications

Component Checklist	page 1-1
System Overview	page 1-3
Specifications	page 1-7

COMPONENT CHECKLIST

A typical Rosemount Two-Wire In-Situ Oxygen Analyzer should contain the items shown in Figure 1-1. Record the part number, serial number, and order number for each component of your system in the table located on the first page of this manual.

Also, use the product matrix in Table 1-1 at the end of this section to compare your order number against your unit. The first part of the matrix defines the model. The last part defines the various options and features of the Rosemount 5081FG Analyzer. Ensure the features and options specified by your order number are on or included with the unit.

Figure 1-1. Typical System Package

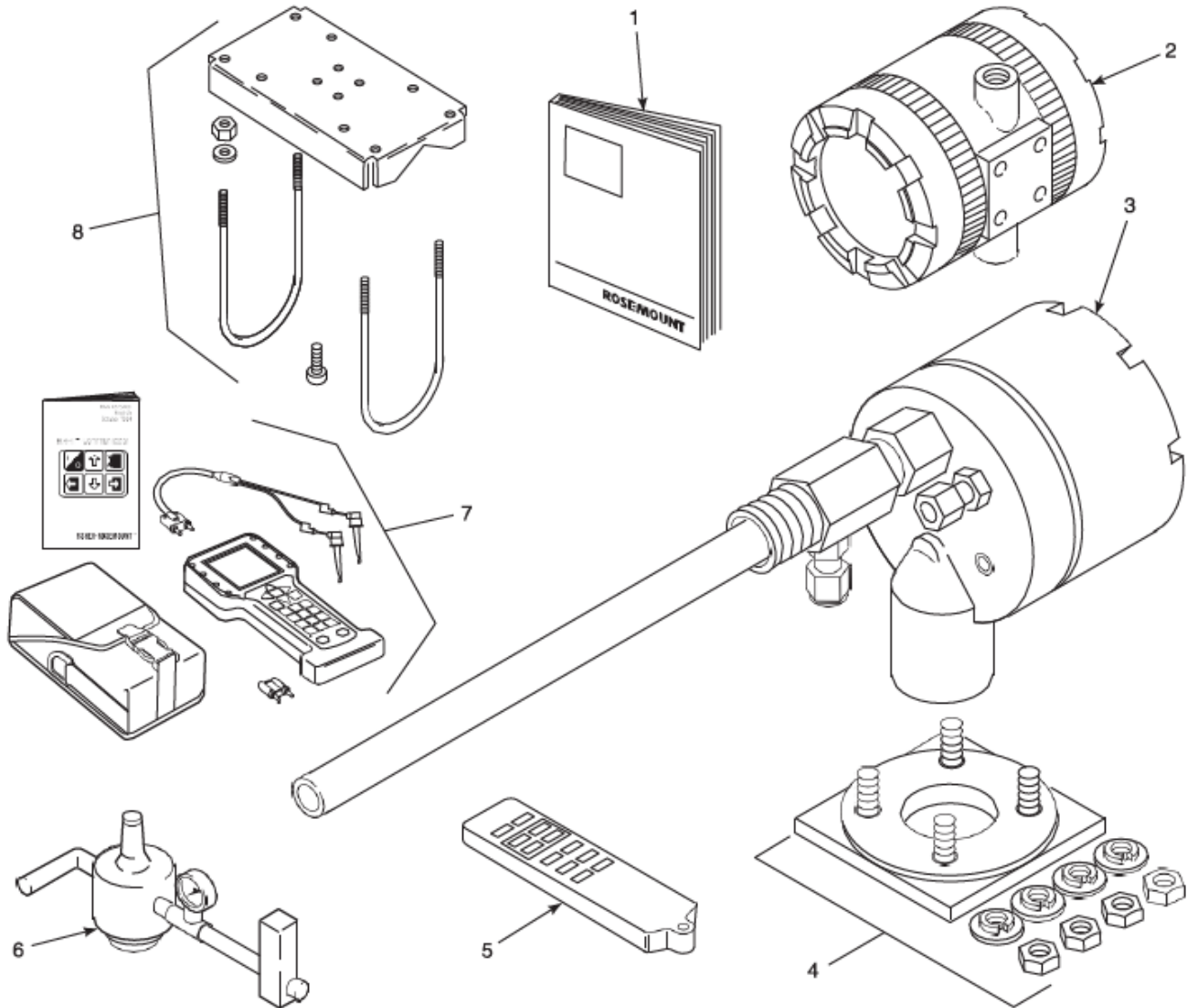

39580001

1. Instruction Manual
2. Rosemount 5081 Transmitter
3. Oxygen Probe
4. Adapter Plate with Mounting Hardware and Gasket (Optional)
5. Infrared Remote Control (IRC)
6. Reference Air Set (Optional)
7. Field Communicator Package (Optional)
8. Pipe Mounting Kit (Optional)

SYSTEM OVERVIEW

Scope

This Instruction Bulletin is designed to supply details needed to install, start up, operate, and maintain the Rosemount Two-Wire In-Situ Oxygen Analyzer. The analyzer consists of an oxygen probe and Rosemount 5081 transmitter. The signal conditioning electronics of the Rosemount 5081 transmitter outputs a 4-20 mA signal representing an O₂ value. An infrared remote control (IRC) allows access to setup, calibration, and diagnostics. This same information, plus additional details, can be accessed with the HART field communicator or Asset Management Solutions (AMS) software.

System Description

The Rosemount Two-Wire In-Situ Oxygen Analyzer is designed to measure the net concentration of oxygen in an industrial process; i.e., the oxygen remaining after all fuels have been oxidized. The oxygen probe is permanently positioned within an exhaust duct or stack and performs its task without the use of a sampling system. Rosemount 5081 transmitter is mounted remotely and conditions the oxygen probe outputs.

The equipment measures oxygen percentage by reading the voltage developed across a heated electrochemical cell, which consists of a small yttria stabilized, zirconia disc. Both sides of the disc are coated with porous metal electrodes. When operated at the proper temperature, the millivolt output voltage of the cell is given by the following Nernst equation:

$$EMF = KT \log_{10}(P1/P2) + C$$

Where:

1. P2 is the partial pressure of the oxygen in the measured gas on one side of the cell.
2. P1 is the partial pressure of the oxygen in the reference air on the opposite side of the cell.
3. T is the absolute temperature.
4. C is the cell constant.
5. K is an arithmetic constant.

NOTE

For best results, use clean, dry, instrument air (20.95% oxygen) as the reference air.

NOTE

The probe uses a Type B thermocouple to measure the cell temperature.

When the cell is at operating temperature and there are unequal oxygen concentrations across the cell, oxygen ions will travel from the high oxygen partial pressure side to the low oxygen partial pressure side of the cell. The resulting logarithmic output voltage is approximately 50 mV per decade.

The output is proportional to the inverse logarithm of the oxygen concentration. Therefore, the output signal increases as the oxygen concentration of the sample gas decreases. This characteristic enables the Rosemount Two-Wire In-Situ Oxygen Analyzer to provide exceptional sensitivity at low oxygen concentrations.

Rosemount 5081FG

The oxygen analyzer measures net oxygen concentration in the presence of all the products of combustion, including water vapor. Therefore, it may be considered an analysis on a “wet” basis. In comparison with older methods, such as the portable apparatus, which provides an analysis on a “dry” gas basis, the “wet” analysis will, in general, indicate a lower percentage of oxygen. The difference will be proportional to the water content of the sampled gas stream.

System Configuration

The equipment discussed in this manual consists of two major components: the oxygen probe and the Rosemount 5081 transmitter.

Oxygen probes are available in three length options, providing In-Situ penetration appropriate to the size of the stack or duct. The options on length are 20 in. (508 mm), 26 in. (660 mm), or 38 in. (965 mm).

Rosemount 5081 transmitter is a two-wire transmitter providing an isolated output, 4-20 mA, that is proportional to the measured oxygen concentration. A customer-supplied 24 VDC power source is required to simultaneously provide power to the electronics and a 4-20 mA signal loop. The transmitter accepts millivolt signals generated by the probe and produces the outputs to be used by other remotely connected devices. The output is an isolated 4-20 mA linearized current.

System Features

1. The cell output voltage and sensitivity increase as the oxygen concentration decreases.
2. High process temperatures eliminate the need for external cell heating and increase cell accuracy.
3. HART communication is standard. To use the HART capability, you must have either:
 - (a) Field Communicator
 - (b) Asset Management Solutions (AMS) software for the PC
4. Easy probe replacement due to the light-weight, compact probe design.
5. Remote location of the Rosemount 5081 transmitter removes the electronics from high temperature or corrosive environments.
6. Power is supplied to the electronics through the 4-20 mA line for intrinsic safety (IS) purposes.
7. Infrared remote control (IRC) allows interfacing without exposing the electronics.

8. An operator can operate and diagnostically troubleshoot the Two-Wire In-Situ Oxygen Analyzer in one of two ways:
 - a. Infrared Remote Control. The IRC allows access to fault indication menus on the Rosemount 5081 transmitter LCD display. Calibration can be performed from the IRC keypad.
 - b. Optional HART Interface (Figure 1-2). The Two-Wire In-Situ Oxygen Analyzer's 4-20 mA output line transmits an analog signal proportional to the oxygen level. The HART output is superimposed on the 4-20 mA output line. This information can be accessed through the following:
 - Field Communicator - The field communicator requires Device Description (DD) software specific to the Two-Wire In-Situ Oxygen Analyzer. The DD software will be supplied with many field communicators but can also be programmed into existing units at most Fisher-Rosemount service offices. See Section 4: HART/AMS, for additional HART information.
 - Personal Computer (PC) - The use of a personal computer requires AMS software available from Fisher-Rosemount.
9. Selected Distributed Control Systems - The use of distributed control systems requires input/output (I/O) hardware and AMS Security codes are provided to (by infrared remote control) prevent unintended changes to analyzers adjacent to the one being accessed.
10. A calibration check procedure is provided to determine if the Rosemount Two-Wire In-Situ Oxygen Analyzer is correctly measuring the net oxygen concentration in the industrial process.

Figure 1-2. Two-Wire In-Situ Oxygen Analyzer HART Connections and AMS Application

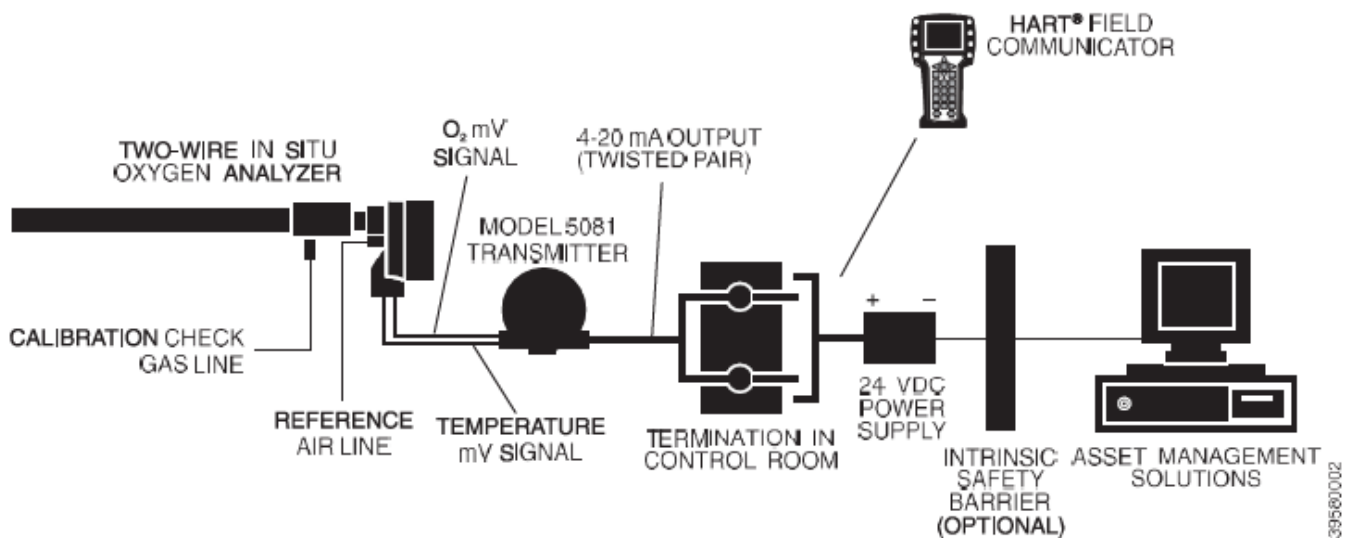

Handling the Analyzer

The probe was specially packaged to prevent breakage due to handling. Do not remove the padding material from the probe until immediately before installation.

⚠ CAUTION

It is important that printed circuit boards and integrated circuits are handled only when adequate antistatic precautions have been taken to prevent possible equipment damage. The oxygen probe is designed for industrial applications. Treat each component of the system with care to avoid physical damage. Some probe components are made from ceramics, which are susceptible to shock when mishandled.

System Considerations

Prior to installing your Rosemount Two-Wire In-Situ Oxygen Analyzer, make sure you have all the components necessary to make the system installation. Ensure all the components are properly integrated to make the system functional.

After verifying that you have all the components, select mounting locations and determine how each component will be placed in terms of available line voltage, ambient temperatures, environmental considerations, convenience, and serviceability. Figure 1-1 shows a typical system package. A typical system installation is shown in Figure 1-3.

Figure 1-3. Typical System Installation

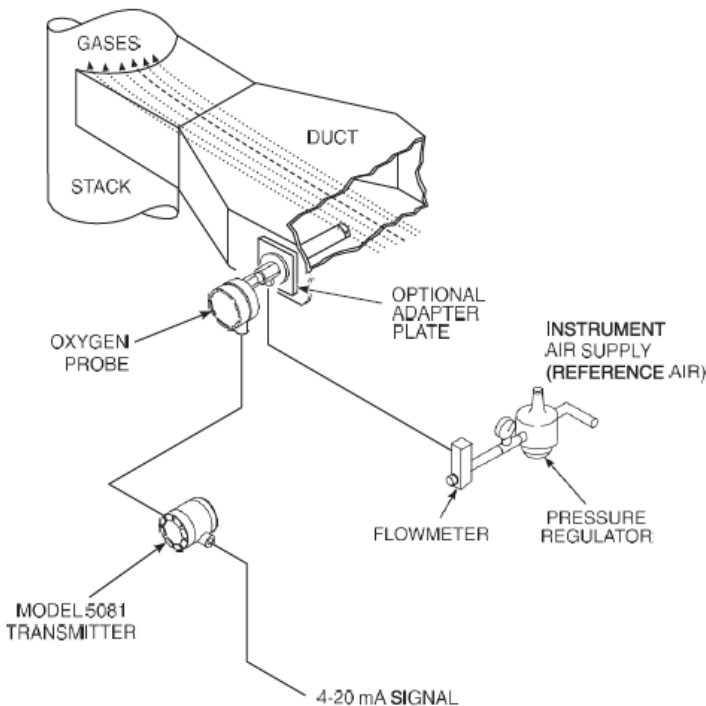

A source of instrument air is optional at the oxygen probe for reference air use. Since the unit is equipped with an in place calibration feature, provisions can be made to permanently connect calibration gas bottles to the oxygen probe.

If the calibration gas bottles will be permanently connected, a check valve is required next to the calibration fittings on the integral electronics.

This check valve is to prevent breathing of the calibration gas line and subsequent flue gas condensation and corrosion. The check valve is in addition to the stop valve in the calibration gas kit.

NOTE:

The electronics is rated Type 4X (IP65) and is capable of operation at temperatures up to 65°C (149°F).

Retain the packaging in which the Rosemount Two-Wire In-Situ Oxygen Analyzer arrived from the factory in case any components are to be shipped to another site. This packaging has been designed to protect the product.

SPECIFICATIONS

Transmitter	
Net O ₂ Range	0 to 25% O ₂
System Accuracy	±1.5% of reading or 0.05% O ₂ , whichever is greater
System Response in Flue Gas	Initial – less than 3 seconds, T90 – less than 8 seconds
Probe Lengths	20 in. (508 mm) 26 in. (660 mm) 38 in. (965 mm)
Process Temperature Limits:	550° to 1400°C (1022° to 2552°F) Operation to 1600°C (2912°F) with reduced cell life
Ambient Temperature Limits:	-40° to 149°C (-40° to 300°F)
Mounting and Mounting Position	Vertical or horizontal
Materials of Construction (Process Wetted Parts):	
Inner Probe	Zirconia
Outer Protection Tube	Alumina [1600°C (2912°F) limit] Inconel 600 [1000°C (1832°F) limit]
Probe Junction Box	Cast aluminum
Speed of Installation/Withdrawal	1 in. (25,4 mm) per minute
Hazardous Area Certification	See Section 8.
Reference Air Requirement	100 m per minute (2,119 scfh) of clean, dry instrument air; 1/4 in. tube fittings
Calibration Check Gas Fittings	1/4 in. tube fittings
Cabling	Two twisted pairs, shielded

Continued on Next Page

Electronics

Electronics Enclosure	TYPE 4X (IP65), weatherproof, and corrosion-resistant
Materials of Construction	Low copper aluminum
Ambient Temperature Limits	-20° to 65°C (-4° to 149°F)
Relative Humidity	95% with covers sealed
Power Supply and Load Requirements	See Figure 1-4
Inputs (from O ₂ Probe)	Two wires - O ₂ signal Two wires - type B thermocouple
Output	One 4-20 mA signal with superimposed digital HART signal
Hazardous Area Certification	See Section 8.
Power Transient Protection	IEC 801-4
Shipping Weight	10 lbs (4,5 kg)

Infrared Remote Control

Power Requirements	Three AAA batteries
Hazardous Area Certification	ATEX EEx ia IIC Class 1, Div 1, Group A, B, C, D

Figure 1-4. Power Supply and Load Requirements

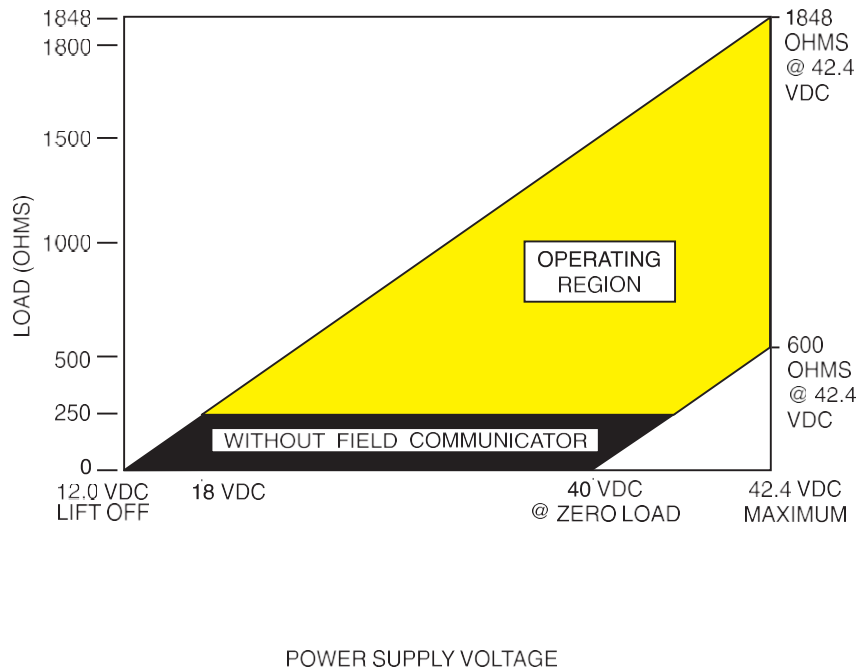

39560007

Table 1-1. Product Matrix

5081FG High Temperature Oxygen Flue Gas Analyzer

Code	Sensing Probe Type
1	20 in. (508 mm) probe, 1/4 in. tube fittings
2	26 in. (660 mm) probe, 1/4 in. tube fittings
3	38 in. (965 mm) probe, 1/4 in. tube fittings
Code	Probe Outer Tube Material - Maximum Operating Temperature
1	Alumina - 2912°F (1600°C) maximum - 1.25 NPT mounting
2	Inconel Alloy - 1832°F (1000°C) maximum - 1.25 NPT mounting
Code	Mounting Adapter- Stack Side
0	No adapter plate required uses 1.25 NPT ("0" must also be chosen under "Mounting Adapter" below)
1	New flanged installation - Square weld plate with studs (matches "Mounting Adapter" below)
2	Model 450 mounting ("4" must also be chosen under "Mounting Adapter" below)
3	Competitor's Mount ("5" must also be chosen under "Mounting Adapter" below)
Code	Mounting Adapter - Probe Side
0	No adapter plate
1	ANSI 2 in. 150 lb flange to 1.25 NPT adapter (6 in. dia. flange, 4.75 in. BC with 4 x 0.75 in. dia. holes)
2	DIN to 1.25 NPT adapter (184 mm flange, 145 mm BC with 4 x 18 mm dia. holes)
3	JIS to 1.25 NPT adapter (155 mm flange, 130 mm BC with 4 x 13 mm dia. holes)
4	Model 450 to 1.25 NPT adapter
5	Competitor's mounting flange
Code	Electronics & Housing TYPE 4X, IP65
H1	5081-G HART Electronics – ATEX/IECEX
H2	5081-G HART Electronics - CSA
H3	5081-G HART Electronics - FM
Code	Housing Mounting
1	Surface or wall mounting
2	1/2 to 2 in. pipe mounting
Code	Communications
1	No remote control
2	Infrared Remote Control (IRC) (LCD display through cover window)
Code	Calibration Accessories
1	No hardware
2	Calibration and reference air flowmeters and reference air pressure regulator
Code	Armored Cable Length
00	No cable
11	20 ft (6 m)
12	40 ft (12 m)
13	60 ft (18 m)
14	80 ft (24 m)
15	100 ft (30 m)
16	150 ft (45 m)
17	200 ft (61 m)
18	300 ft (91 m)
19	400 ft (122 m)
20	500 ft (152 m)

5081FG 2 1 0 0 1 1 1 2 11 Example

Section 2 Installation

Pre-Installation	page 2-2
Mechanical Installation	page 2-2
Electrical Installation	page 2-11
Pneumatic Installation	page 2-14

⚠ WARNING

Before installing this equipment, read the “Safety instructions for the wiring and installation of this apparatus” in Appendix A. Failure to follow safety instructions could result in serious injury or death.

PRE-INSTALLATION

Inspect

Carefully inspect the shipping container for any evidence of damage. If the container is damaged, notify the carrier immediately.

Packing List

Confirm that all items shown on the packing list are present. Notify Rosemount immediately if items are missing.

⚠ WARNING

Before installing this equipment, read the "Safety instructions for the wiring and installation of this apparatus" in Appendix A. Failure to follow safety instructions could result in serious injury or death.

MECHANICAL INSTALLATION

⚠ CAUTION

Avoid installation locations near steam soot blowers.

Locating Oxygen Probe

1. The location of the oxygen probe in the stack or flue is important for maximum accuracy in the oxygen analyzing process. The probe must be positioned so the gas it measures is representative of the process. Longer ducts may require several analyzers since the O₂ can vary due to stratification. A point too near the wall of the duct, or the in-side radius of a bend, may not provide a representative sample because of the very low flow conditions. The sensing point should be selected so the process gas temperature falls within a range of 550° to 1400°C (1022° to 2552°F). Figure 2-1 provides mechanical installation references.
2. Check the flue or stack for holes and air leakage. The presence of this condition will substantially affect the accuracy of the oxygen reading. Therefore, either make the necessary repairs or install the probe upstream of any leakage.
3. Ensure the area is clear of internal and external obstructions that will interfere with installation and maintenance access to the probe. Allow adequate clearance for probe removal (Figure 2-1).

Figure 2-1. Probe Installation Details

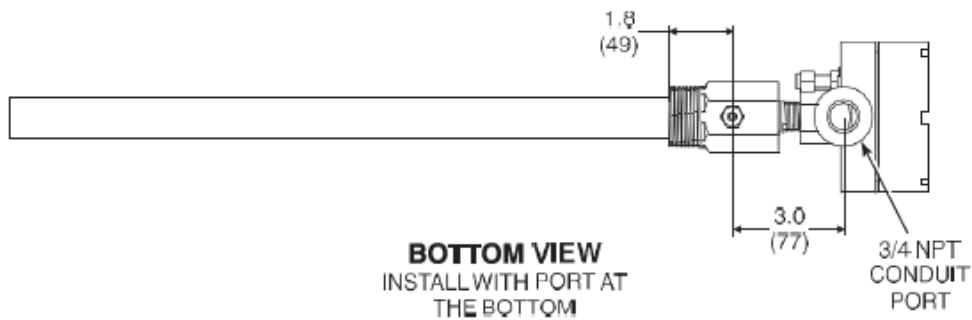
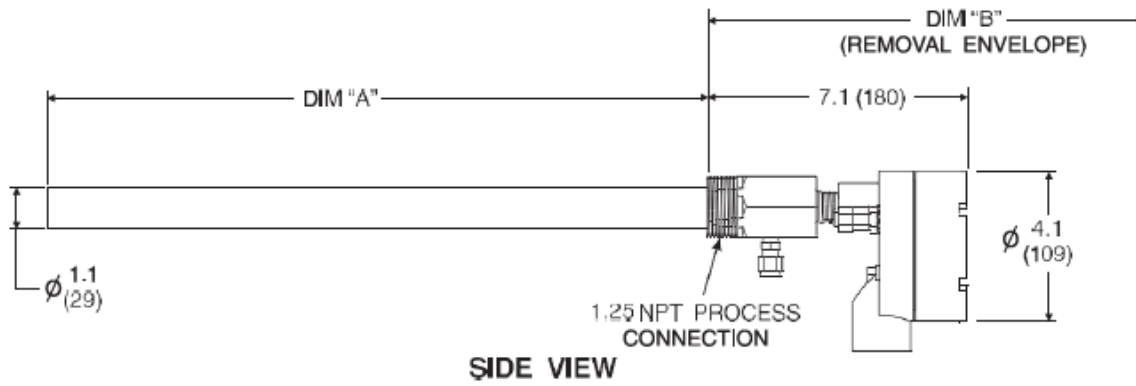
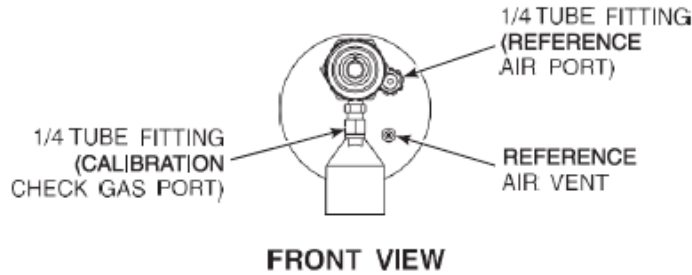

TABLE 1. INSTALLATION (REMOVAL)		
PROBE	DIM "A"	DIM "B"
20 IN.	20 (508)	31 (787)
26 IN.	26 (660)	37 (940)
38 IN.	38 (965)	49 (1244)

NOTE: DIMENSIONS ARE IN INCHES WITH MILLIMETERS IN PARENTHESES.

38580004

Installing Oxygen Probe

⚠ CAUTION

The probe was specially packaged to prevent breakage due to handling. Do not remove the padding material from the probe until immediately before installation.

1. Ensure all components are available to install the probe.

NOTE

Leave the probe inner protective cover in place until installation. This is required to protect the ceramic cell during movement.

2. If using an optional adapter plate (Figure 2-2) or an optional mounting flange (Figure 2-3), weld or bolt the component onto the duct. The through hole in the stack or duct wall and refractory material must be 2 in. (50,8 mm) diameter, minimum.
3. If the optional adapter plates are not used, a 2 in. NPT, schedule 40, pipe nipple (Figure 2-4) should be welded to the stack or duct wall. When a 2 in. NPT to 1.25 NPT adapter is threaded to the welded pipe nipple, the adapter provides the pipe threads needed for the probe's process fitting.
4. Where high particulate or slag is in the flue gas stream, it may be desirable to inset the probe in the refractory as shown in Figure 2-5. Use pipe couplings and nipples to adjust the probe insertion depth.
5. Use high temperature material (alumina wool) to seal around the probe during insertion. This prevents hot gases from escaping or cold air from entering the stack or duct.
6. Initially insert the probe to a depth of 3 in. (76,2 mm) or 1/2 the depth of the stack or duct refractory, whichever is greater.

⚠ CAUTION

After initial insertion, do not insert the probe at a rate exceeding 1 in. per minute (25.4 mm per minute) or damage to the probe may result due to thermal shock.

7. After initial insertion, insert the probe at a rate of 1 in. (25,4 mm) per minute until the probe is fully inserted.
8. Install anti-seize compound on the pipe threads and screw the probe into the process flange or adapter.
9. If insulation was removed to access the duct work for probe mounting, make sure the insulation is replaced. See Figure 2-4.

⚠ CAUTION

If the ducts will be washed down during outage, MAKE SURE to power down the probes and remove them from the wash area.

Figure 2-2. Optional Adapter Plate

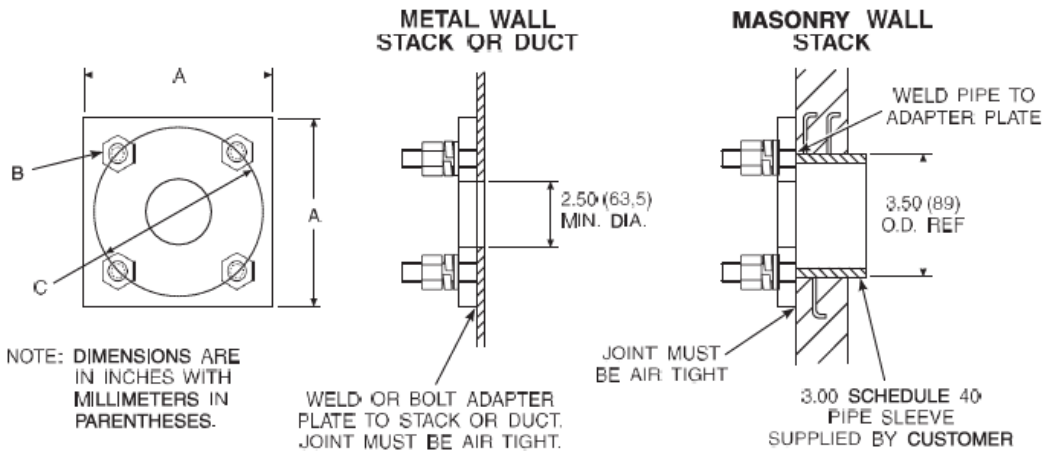
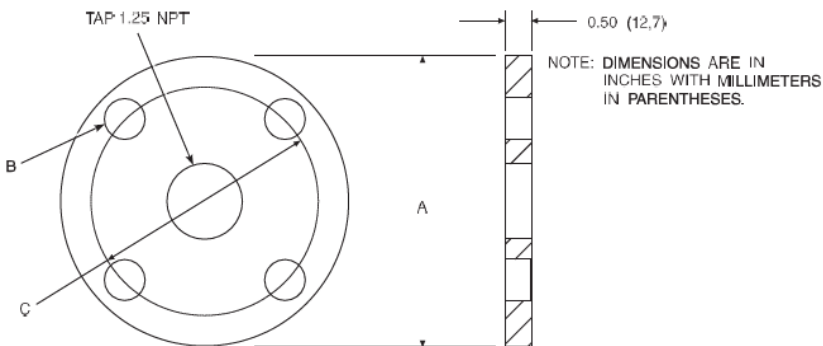

PLATE DIMENSIONS			
DIMENSION	ANSI 4512C34G01	DIN 4512C36G01	JIS 4512C35G01
"A"	6.00 (153)	7.5 (191)	6.50 (165)
"B" THREAD	0.625-11	M-16x2	M-12x1.75
"C" DIA.	4.75 (121)	5.71 (145)	5.12 (130)

39580008

Figure 2-3. Optional Probe Mounting Flange



FLANGE DIMENSIONS				
DIMENSION	ANSI 5R10158H01	DIN 5R10158H02	JIS 5R10158H03	MODEL 450 5R10158H04
"A" DIA.	6.00 (153)	7.28 (185)	6.10 (155)	9.00 (229)
"B" DIA.	0.75 (20)	0.71 (18)	0.59 (15)	0.50 (13)
"C" DIA.	4.75 (121)	5.71 (145)	5.12 (130)	7.68 (195)

Rosemount 5081FG

Figure 2-4. Horizontal Probe Installation

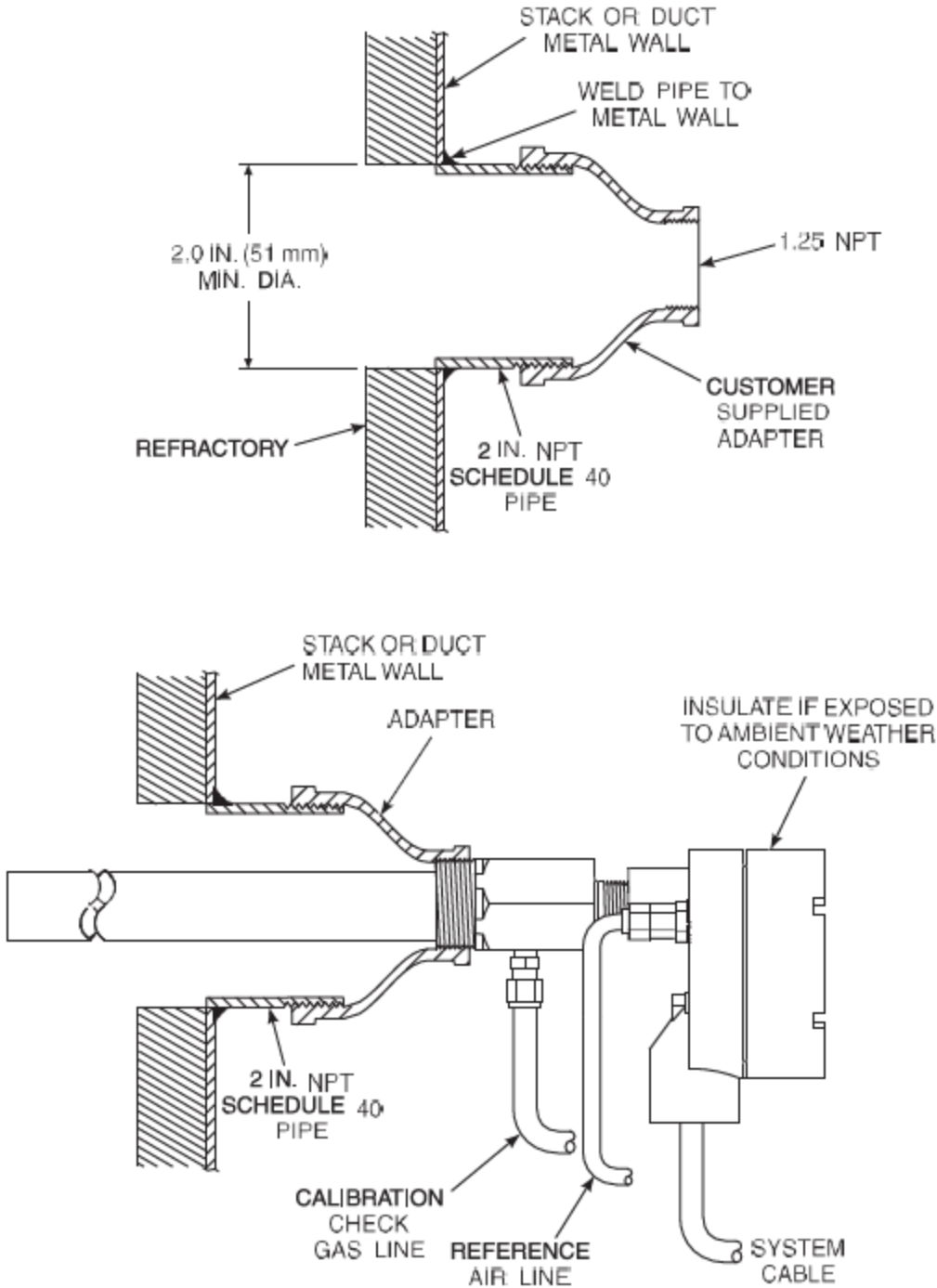

30690010

Figure 2-5. Adjusting Probe Insertion Depth

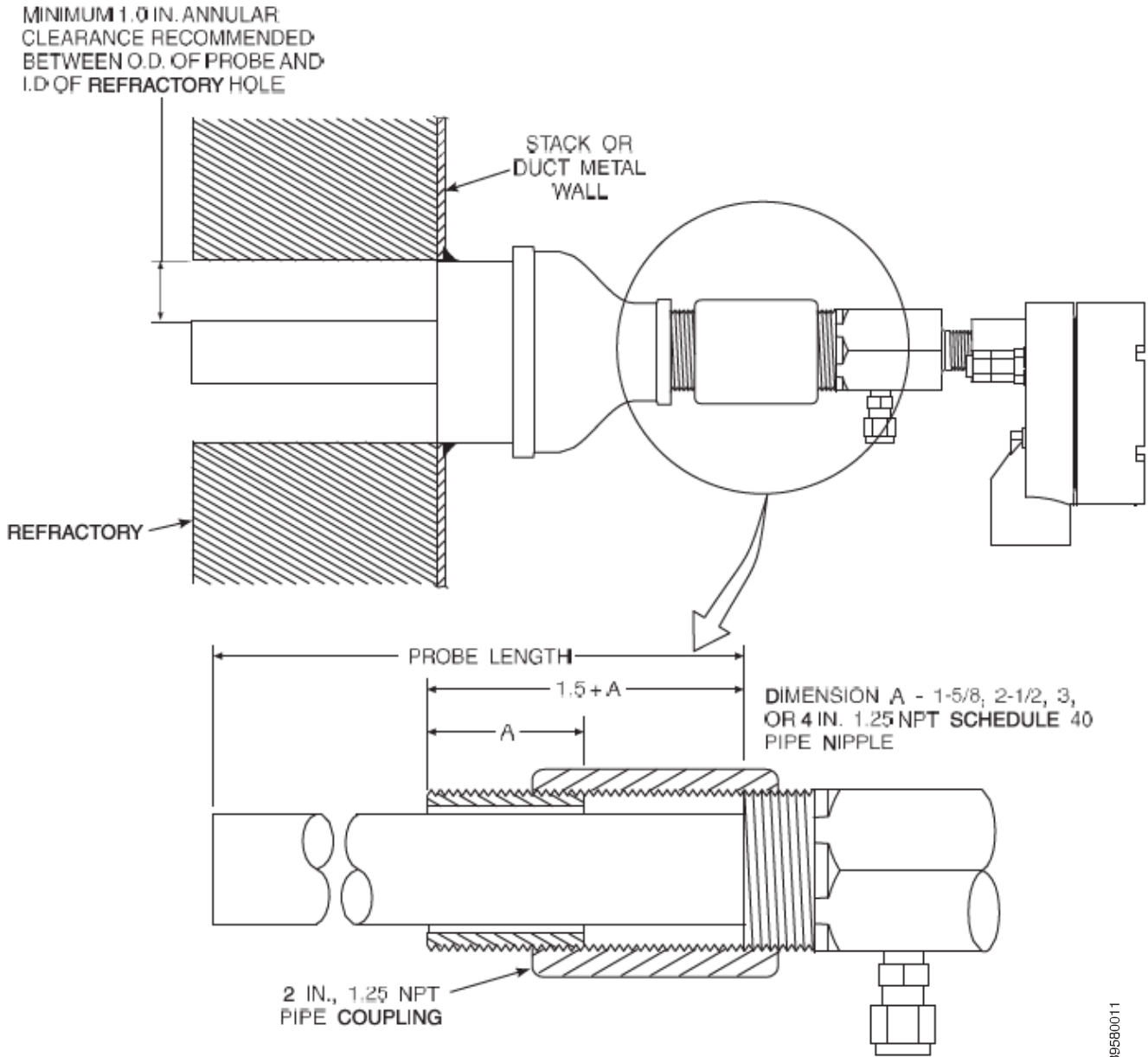

Locating Rosemount 5081 Transmitter

1. Ensure the Rosemount 5081 transmitter is easily accessible for maintenance and service and for using the infrared remote control (if applicable).

⚠ CAUTION

Do not allow the temperature of the Rosemount 5081 transmitter exceed 65°C (149°F) or damage to the unit may result.

Rosemount 5081FG

2. The ambient temperature of the transmitter housing must not exceed 65°C (149°F). Locate the electronics in an area where temperature extremes, vibration, and electromagnetic and radio frequency interference are minimal.
3. Locate the Rosemount 5081 transmitter within 150 ft (45,7 m) of the oxygen probe due to wiring and signal considerations.

Installing Rosemount 5081 Transmitter

1. Ensure all components are available to install the Rosemount 5081 transmitter.
2. Choose a method or location to mount the transmitter.
 - a. Flat Surface Mounting. The transmitter may be mounted on a flat surface using the threaded mounting holes located on the bottom of the transmitter housing. Refer to Figure 2-6 for installation references.
 - b. Pipe Mounting. An optional pipe mounting bracket is available for this type of installation. Refer to Figure 2-7 for installation references.

Figure 2-6. Flat Surface Mounting Dimensions

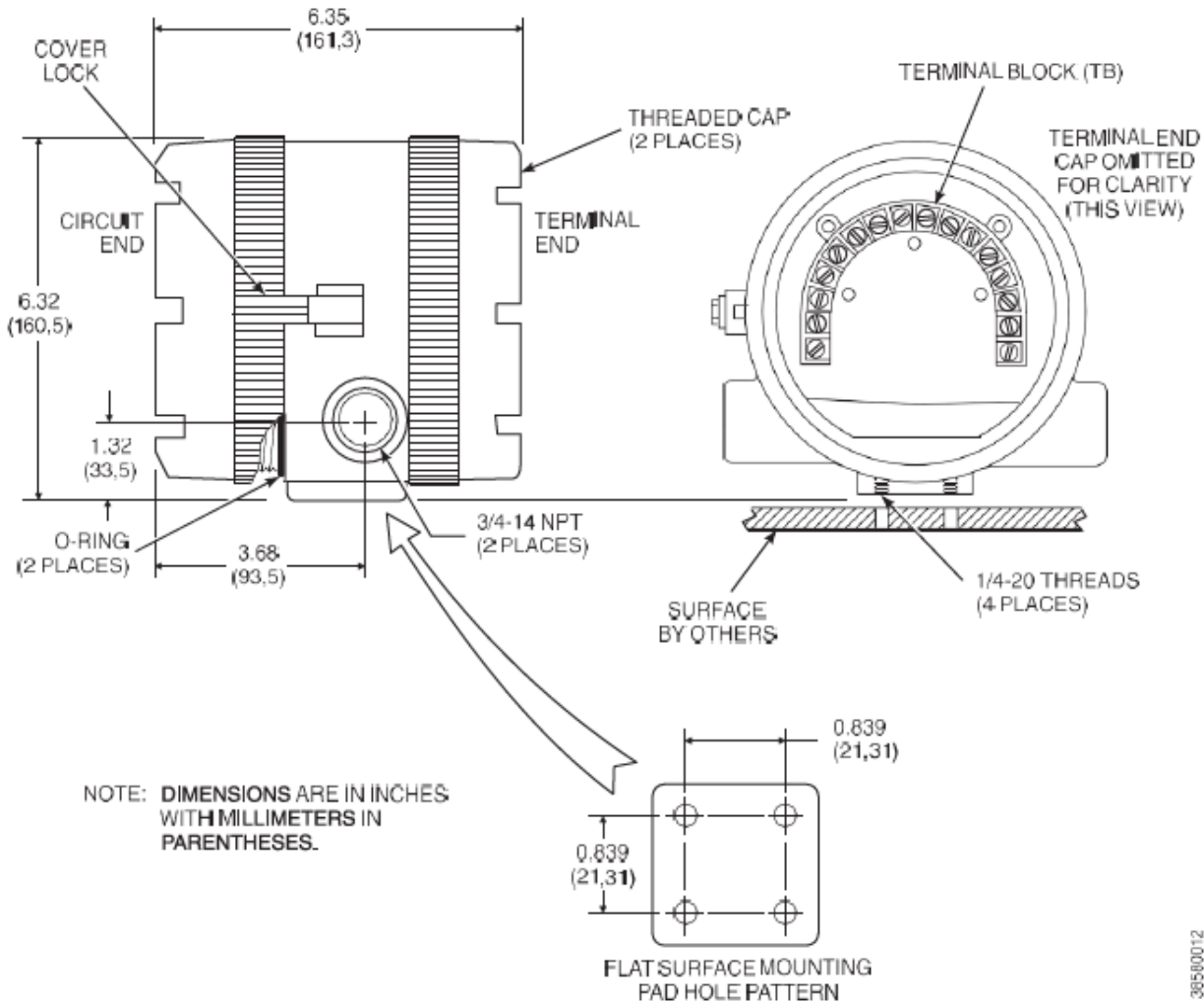

36580012

Figure 2-7. Pipe Mounting Dimensions

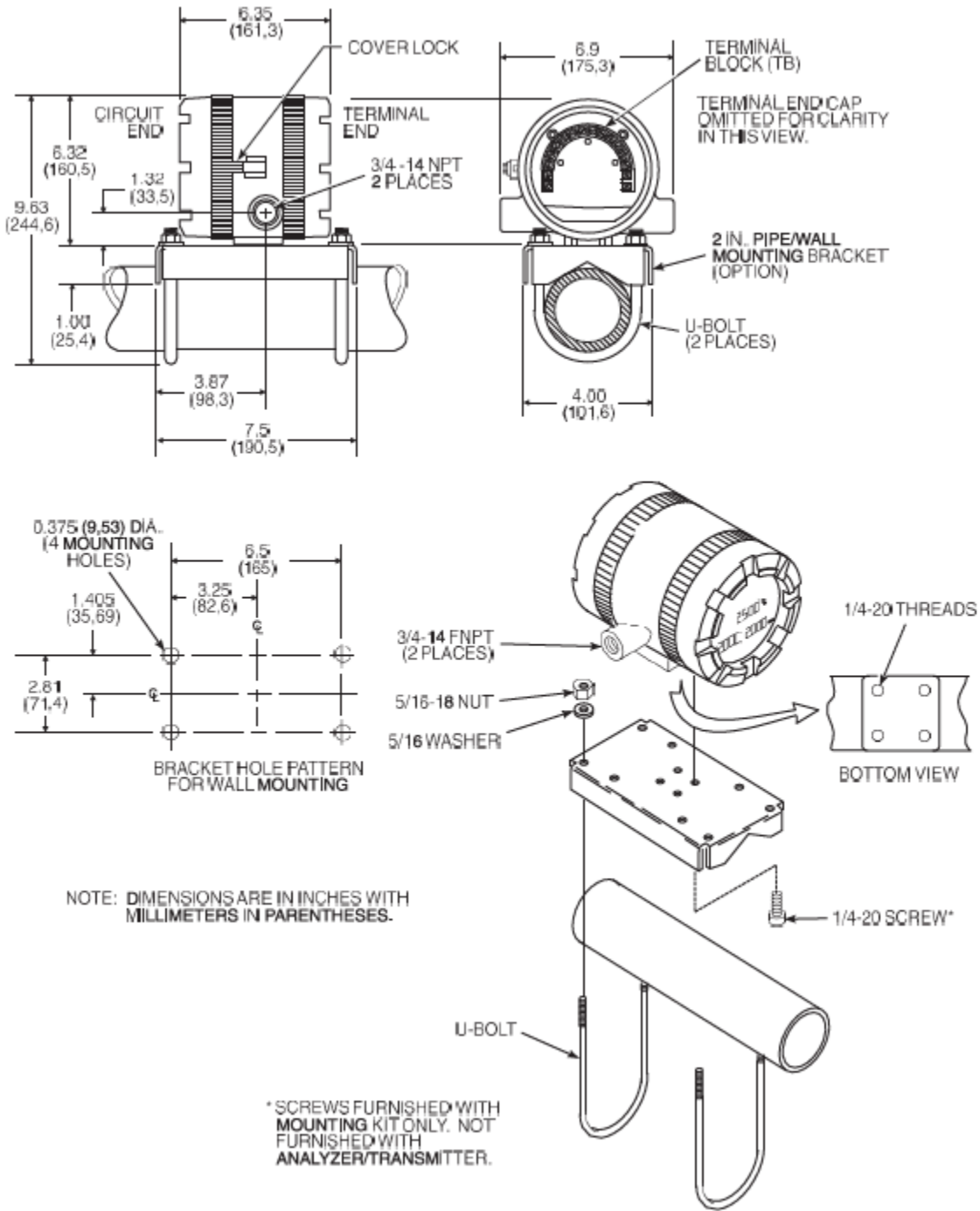

3. For correct viewing orientation, the display may be changed 90 degrees, using the following procedure:
 - a. Refer to Figure 2-8. Loosen the cover lock screw until the cover lock is disengaged from the knurled surface on the threaded circuit end cap.
 - b. Remove the circuit end cap.
 - c. Remove the three screws retaining the display board in place.
 - d. Lift and rotate the display board 90 degrees either way.
 - e. Reposition the display board on the standoffs. Install and tighten all three screws.
 - f. Install the circuit end cap and tighten the cover lock screw to secure the cover lock in place.

Figure 2-8. Display Positioning Assembly

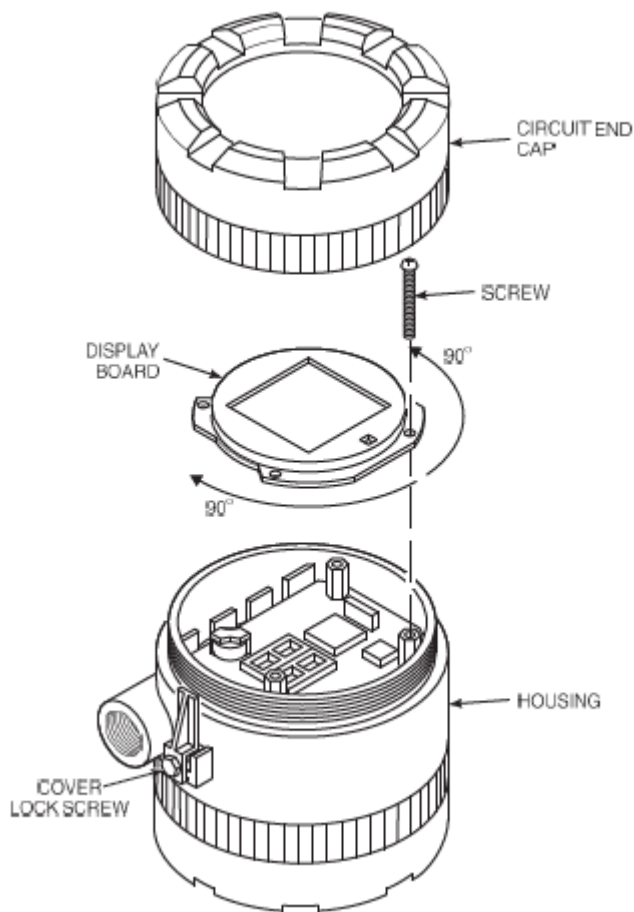

38580014

**ELECTRICAL
INSTALLATION**

All wiring must conform to local and national codes.

⚠ WARNING

For intrinsically safe applications, refer to the installation drawings on Emerson.com for the model 5081FG.

⚠ WARNING

Disconnect and lock out power before connecting the unit to the power supply.

⚠ WARNING

Install all protective equipment covers and safety ground leads after installation. Failure to install covers and ground leads could result in serious injury or death.

⚠ WARNING

To meet the Safety Requirements of IEC 61010 (EC requirement), and ensure safe operation of this equipment, connection to the main electrical power supply must be made through a circuit breaker (min 10 A) which will disconnect all current-carrying conductors during a fault situation. This circuit breaker should also include a mechanically operated isolating switch. If not, then another external means of disconnecting the supply from the equipment should be located close by. Circuit breakers or switches must comply with a recognized standard such as IEC 947.

General

The power supply and signal wiring should be shielded. Also, make sure the signal wiring is grounded at the Rosemount 5081 transmitter end only. Do not ground the signal loop at more than one point. Twisted pairs are recommended. Ground the transmitter housing to an earth ground to prevent unwanted electromagnetic interference (EMI) or radio frequency interference (RFI).

NOTE

For optimum EMI/RFI immunity, shield the 4-20 mA current loop cable and enclose in an earth grounded metal conduit.

NOTE

Never run signal or sensor wiring in the same conduit, or open tray, with power cables. Keep signal or sensor wiring at least 12 in. (0,3 m) away from other electrical equipment and 6.5 ft (2 m) from heavy electrical equipment.

⚠ CAUTION

Moisture accumulation in the transmitter housing can affect its performance and may void its warranty.

It is necessary to prevent moisture from entering the Rosemount 5081 transmitter housing. The use of weather-tight cable glands is required. If conduit is used, plug and seal connections on the transmitter housing to prevent moisture accumulation in the terminal side of the housing.

Oxygen Probe Signal Connections

1. Two signals represent the O₂ value and the cell temperature. The probe provides these values to the Rosemount 5081 transmitter for processing and signal conditioning.
2. Wiring connections for the probe are shown in Figure 2-9.

Figure 2-9. Oxygen Probe Terminal Block

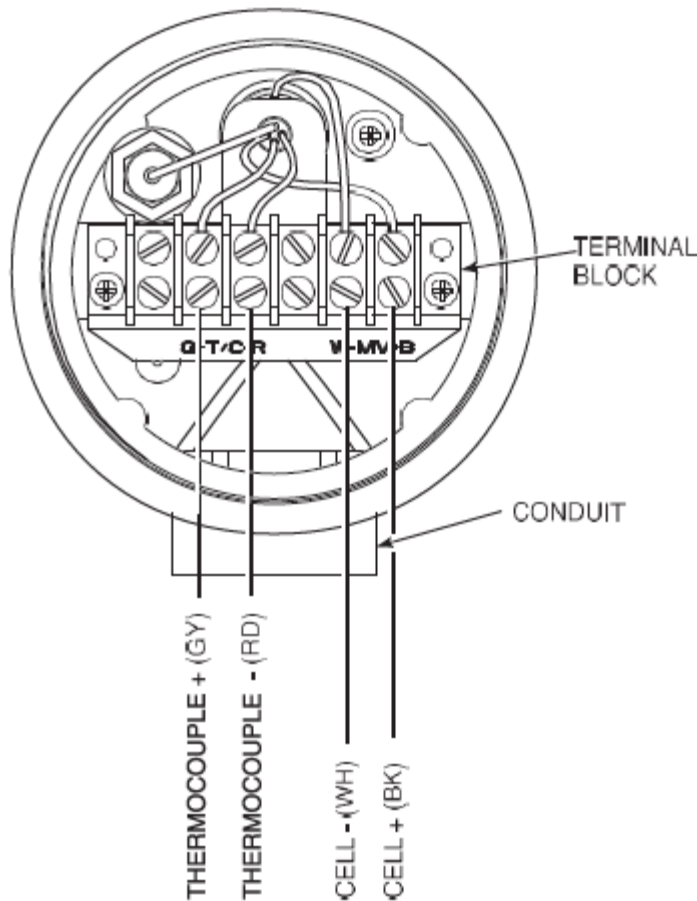

Rosemount 5081 Transmitter 4-20 mA and Signal Connections

1. A 4-20 mA signal represents the O₂ value. Superimposed on the 4-20 mA signal is HART information that is accessible through a HART field communicator or AMS software.
2. Two signals representing the O₂ value and the cell temperature are supplied to the Rosemount 5081 transmitter from the oxygen probe.
3. Wiring connections for the Rosemount 5081 transmitter are shown in Figure 2-10.

NOTE

The ground arrangement shown in Figure 2-10 limits the amount of noise introduced into the electronics.

4. Connect wire shields to terminal 1. Connect earth ground as shown.

Figure 2-10. Transmitter
Terminal Block

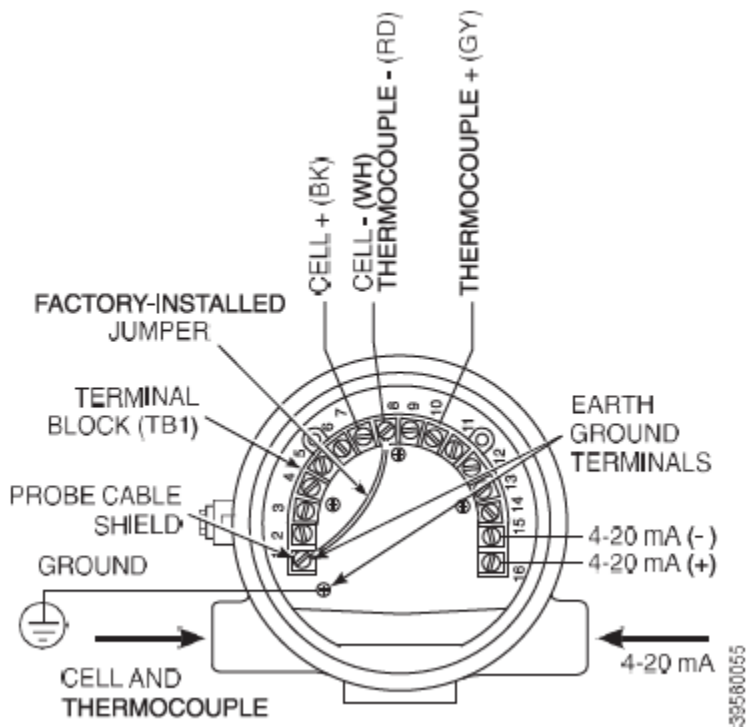

Rosemount 5081FG

PNEUMATIC INSTALLATION

General

Reference air is required for O₂ calculation, and calibration checkgas is required during a calibration check. Refer to Figure 2-11 for the gas connections on the oxygen probe.

Reference Air Package

After the oxygen probe is installed, connect the reference air set. Install the reference air set according to Figure 2-11.

Instrument Air (Reference Air)

Instrument air is required for reference. Refer to the reference air schematic, Figure 2-12. Use 10 psig (68,95 kPa gage) minimum, 225 psig (1551,38 kPa gage) at 0.2 scfh (100 ml/min.); less than 40 parts-per-million total hydrocarbons. Regulator outlet pressure should be set at 5 psi (35 kPa).

Figure 2-11. Air Set, Plant Air Connections

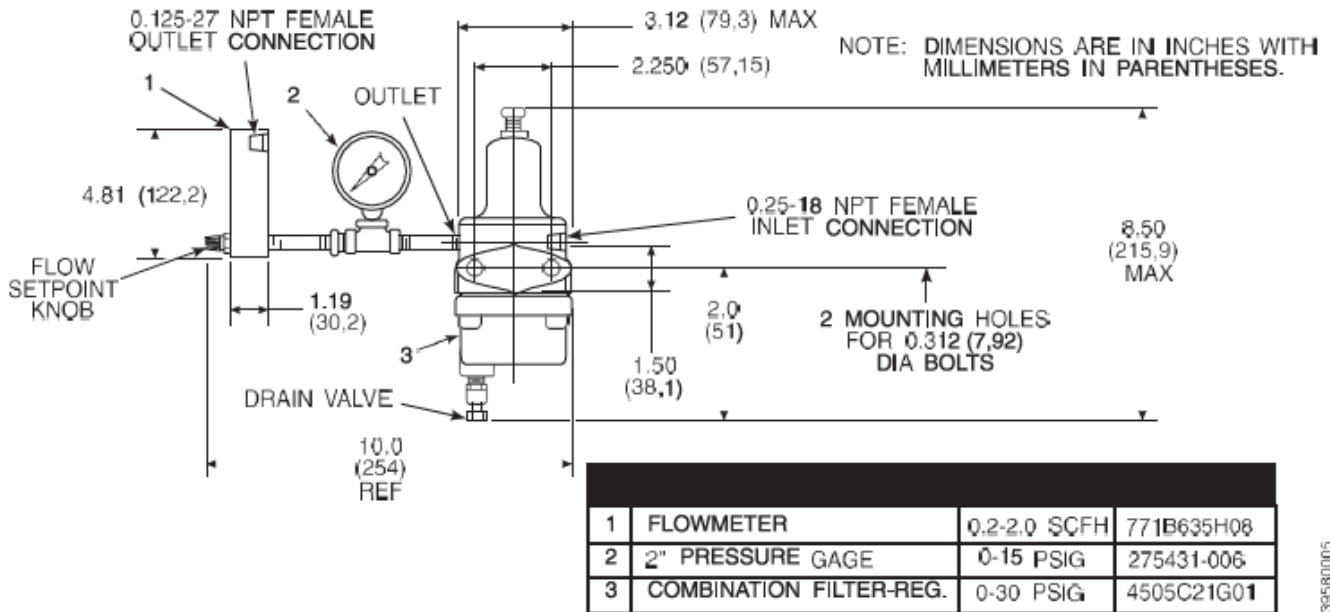
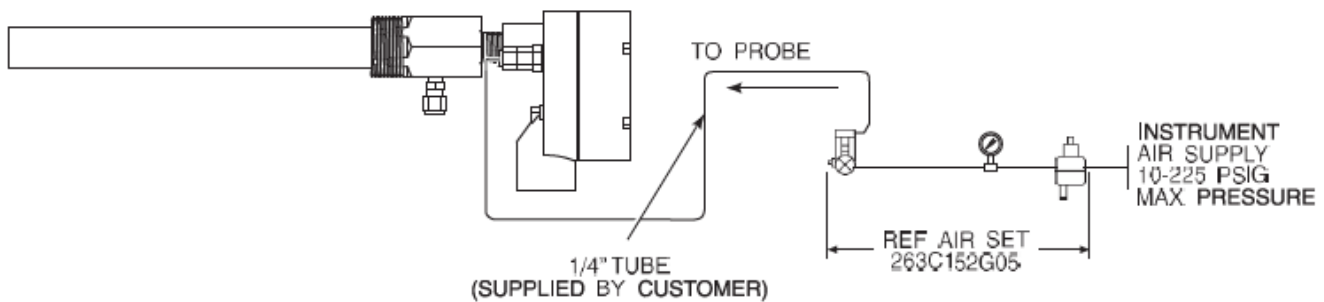

Figure 2-12. Reference Air Schematic



Calibration Gas

Two calibration check gas concentrations are used with the Two-Wire In-Situ Oxygen Analyzer: Low Gas - 0.4% O₂ and High Gas - 8% O₂, each with the balance in nitrogen.

⚠ CAUTION

Do not use 100% nitrogen as a low gas (zero gas). It is suggested that gas for the low (zero) be between 0.4% and 2.0% O₂. Do not use gases with hydrocarbon concentrations of more than 40 parts per million. Failure to use proper gases will result in erroneous readings.

Do not use 100% nitrogen for the low (0%) check gas. See Figure 2-13 for the probe connections. Set both calibration check gases at the same flow rate: 5 scfh (2,5 l/min).

Figure 2-13. Gas Connections at Oxygen Probe

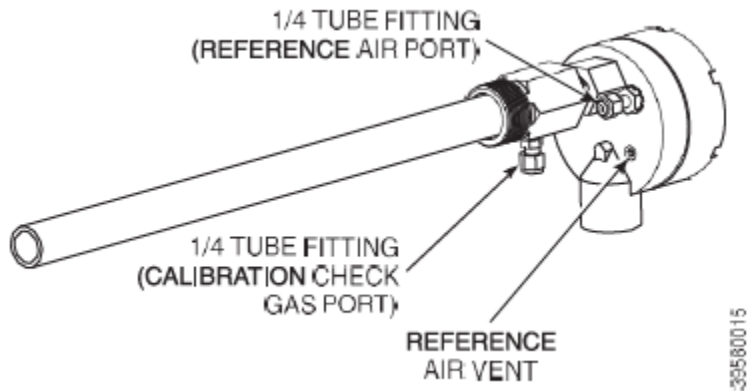

Section 3 Startup and Operation

General	page 3-1
Power Up	page 3-1
Establishing Proper Calibration Gas Flow Rate	page 3-3
Operation	page 3-4
Program Menu	page 3-7
Diagnostics Menu	page 3-16
Cal Check Menu	page 3-21

GENERAL

⚠ WARNING

Install all protective equipment covers and safety ground leads before equipment startup. Failure to install covers and ground leads could result in serious injury or death.

Verify Mechanical Installation

Ensure the Two-Wire In-Situ Oxygen Analyzer is installed correctly. See Mechanical Installation in Section 2: Installation for mechanical installation information.

Verify Terminal Block Wiring

Ensure the wiring of both the oxygen probe terminal block and Rosemount 5081 transmitter terminal block is correct. Refer to Electrical Installation in Section 2: Installation for electrical installation and wiring information.

POWER UP

General

The Two-Wire In-Situ Oxygen Analyzer displays the current oxygen reading on the LCD face of the Rosemount 5081 transmitter. The O₂ concentration, cell temperature, and 4-20 mA output current are displayed as shown in Figure 3-1. This and other information may also be accessed using HART/AMS.

Startup Display

When the probe is first inserted into the stack, some time is required until the minimum operating temperature [550°C (1022°F)] is reached. Some time is also required for the electronics to reach an operating state. Therefore, when the unit is first powered up, a faulted operation display as shown in Figure 3-2 may be displayed by the transmitter until the probe operating temperature is reached and the electronics are working properly (approximately 5 minutes).

Rosemount 5081FG

Operating Display

After the probe has reached operating temperatures, the Rosemount 5081 transmitter display should look similar to Figure 3-1. The display will now track the O₂ concentration, cell temperature, and 4-20 mA output current.

Figure 3-1. Normal Operation Display

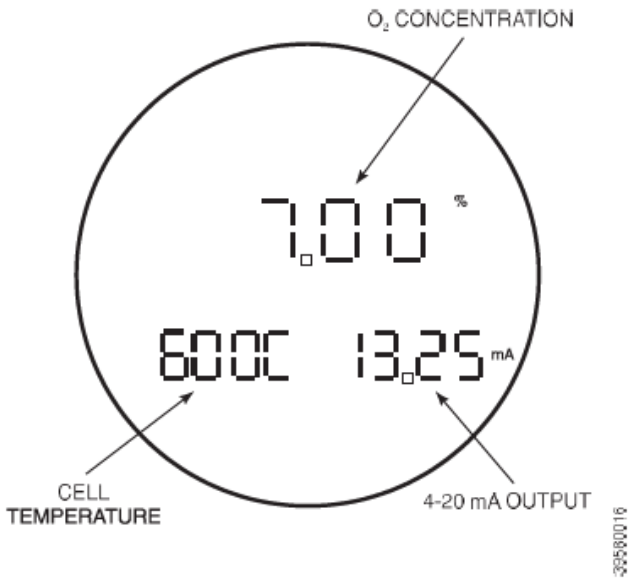

Figure 3-2. Faulted Operation Display



**ESTABLISHING
PROPER CALIBRATION
GAS FLOW RATE**

The calibration gas flow must be enough to ensure that no combustion flue gases mix with the calibration check gases and only clean, good calibration check gas surrounds the cell without expending excess gas (Figure 3-3). Monitor the O₂ concentration using an IRC or a field communicator. Set the calibration check gas flow rate as follows:

NOTE

Only set the calibration check gas flow rate at startup. It is not necessary to perform this procedure for each calibration check.

1. Adjust the calibration check gas flow to 5 scfh (2,5 l/min.) to ensure the cell is surrounded by calibration check gas. Due to the cooling effect of the gas, the cell temperature will decrease slightly, causing the O₂ concentration to drop. Once the electronics compensates for this effect, the O₂ concentration will stabilize.
2. Next, slowly reduce the calibration check gas flow until the O₂ concentration changes, which indicates that the calibration check and flue gases are mixing. Increase the flow rate until this effect is eliminated.

Figure 3-3. Proper Calibration Check Gas Flow Rate

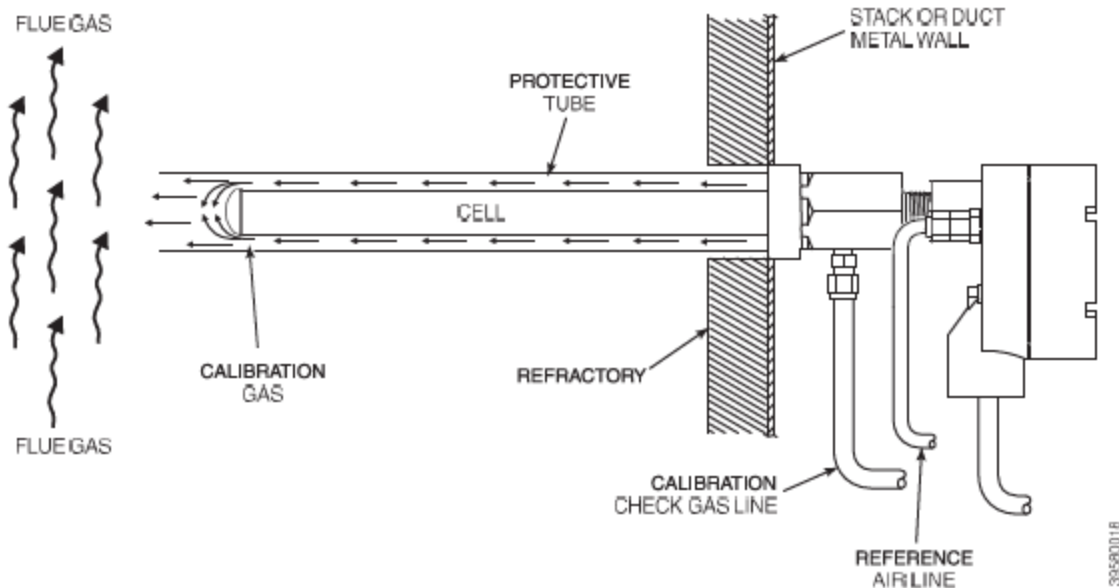

Rosemount 5081FG

OPERATION

Overview

This section explains the operator controls and displays of the Two-Wire In-Situ Oxygen Analyzer. The use of the Infrared Remote Control (IRC) and the Rosemount 5081 transmitter Liquid Crystal Display (LCD) are described in detail.

HART/AMS operation is not covered here. Refer to Section 4: HART/AMS.

Display

The LCD on the circuit end of the Rosemount 5081 transmitter displays O₂ concentration, cell temperature, and 4-20 mA output current during normal operation (Figure 3-4). The LCD will also display fault conditions when they occur. To interact with the transmitter, use the IRC and navigate through a series of menus displayed on the LCD.

Menu Tree

The screens that can be displayed are shown in the menu tree of Figure 3-5. These screens are displayed on the LCD and are accessed using the IRC keypad.

Figure 3-4. Normal Operation Display

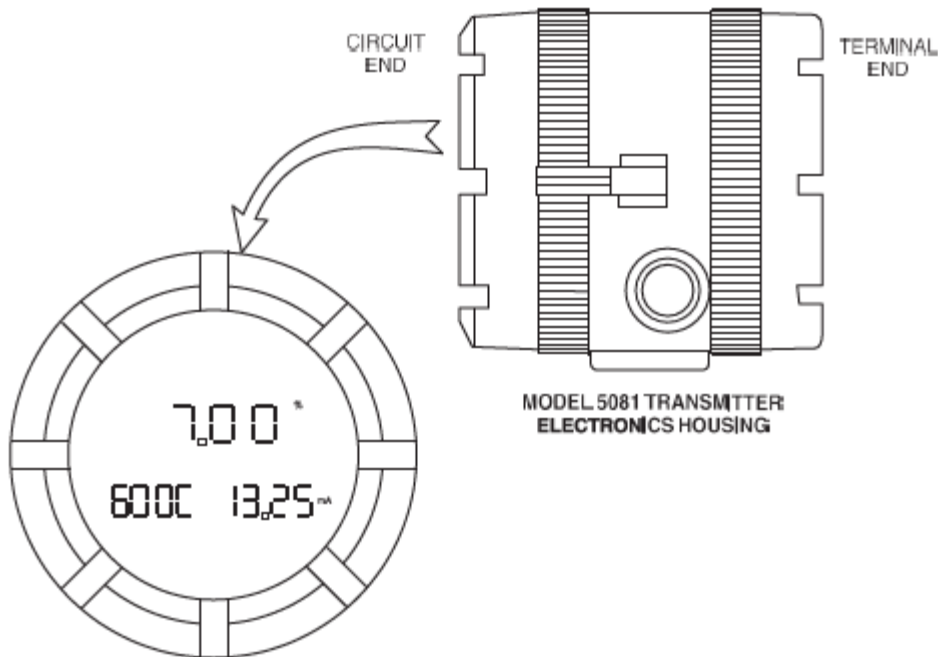

30590019

Figure 3-5. Transmitter Menu Tree

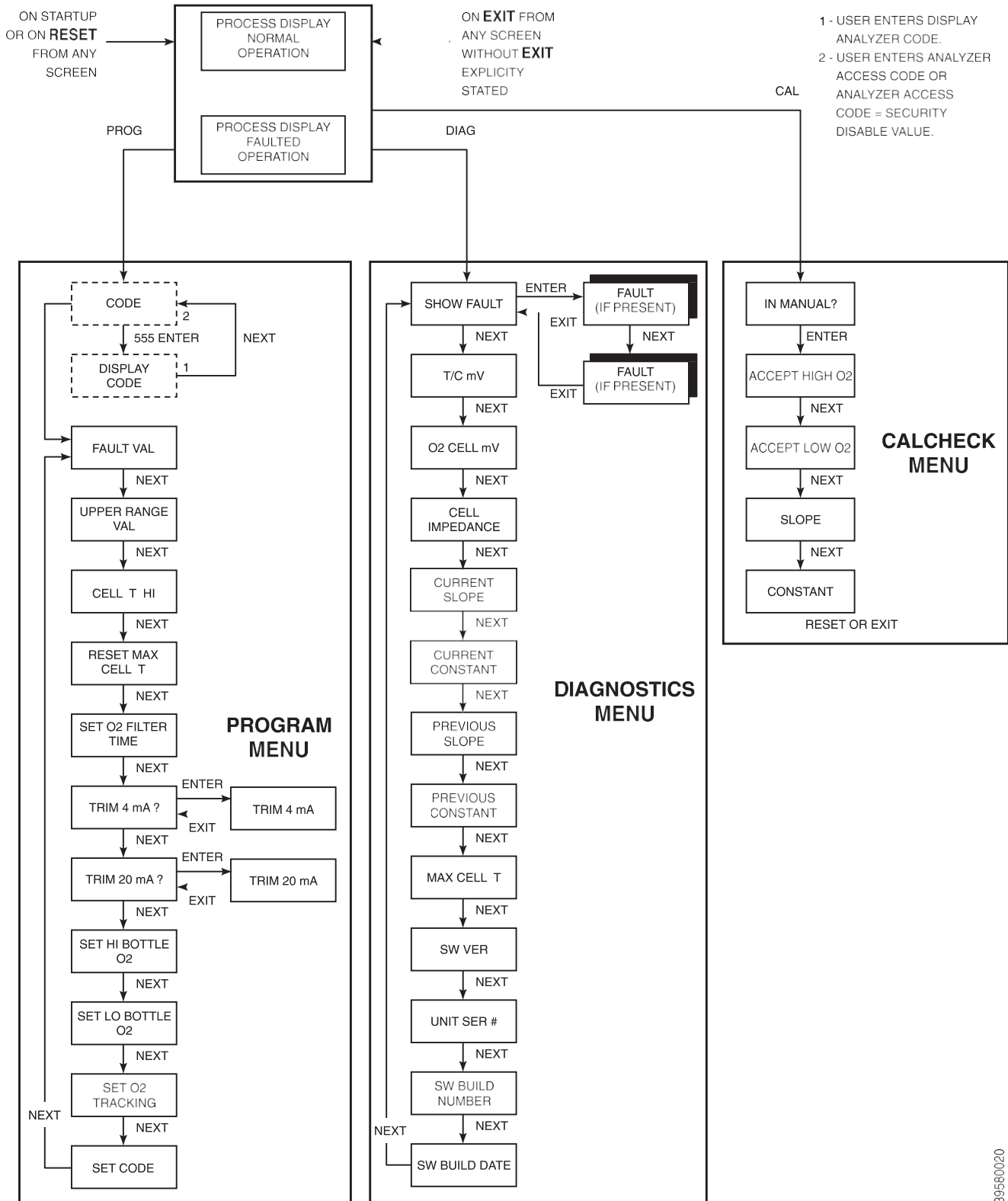

39580020

Rosemount 5081FG

Navigation

The IRC in Figure 3-6 is used to interact with the Rosemount 5081 transmitter and navigate through the screens on the LCD.

1. Hold the IRC within 6 ft (1,8 m) of the Rosemount 5081 transmitter and within 15 degrees from the centerline of the transmitter LCD. The amount of ambient light may also affect IRC performance:

NOTE

The LCD may react slowly to IRC commands. Allow sufficient time between key presses to avoid undesired or repeated commands from accumulating in the command queue.

2. Use the keys on the IRC to navigate through the menu screens. Refer to Figure 3-6. General usage is as follows:
 - a. RESET. Returns to the PROCESS DISPLAY screen at the top of the menu tree. Any non-entered number in the exited state will be ignored, and the previous data will be used.
 - b. HOLD. Not used.
 - c. Left/Right Arrow. Moves left and right among editable digits on the display.
 - d. Up/Down Arrow. Increases or decreases the value of the currently selected digit on the display.
 - e. CAL. Accesses the CALCHECK MENU branch of the menu tree. Only works from the PROCESS DISPLAY screen.

Figure 3-6. Infrared Remote Control (IRC)

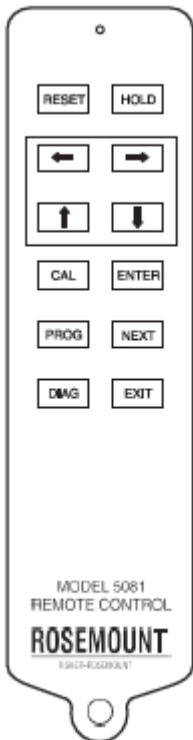

30560021

30560021

- f. PROG. Accesses the PROGRAM MENU branch of the menu tree. Only works from the PROCESS DISPLAY screen.
- g. DIAG. Accesses the DIAGNOSTICS MENU branch of the menu tree. Only works from the PROCESS DISPLAY screen.
- h. ENTER. Initiates the editing process and causes the most significant digit of the edited item to start flashing. Also processes the entry so the previous value updates to the new value entered using the arrow keys. Failure to press ENTER before exiting a screen will cancel the input value and revert to the previous value.
- i. NEXT. Accesses the next user screen as shown in the menu tree. Any non-entered number in the exited state will be ignored, and the previous data will be used.
- j. EXIT. Exits from sub-branches of the menu tree where an exit option is explicitly shown. Otherwise, returns to the PROCESS DISPLAY screen at the top of the menu tree. Any non-entered number in the exited state will be ignored, and the previous data will be used.

PROGRAM MENU

The PROGRAM MENU branch of the menu tree allows you to program and edit some process parameters, faults, outputs, and security codes. To access this branch of the menu tree, press the PROG key on the IRC when in the PROCESS DISPLAY screen (Normal or Faulted). If security is enabled, you must enter the analyzer code to gain further access to the screens in this branch. Each screen in this branch is accessed sequentially using the NEXT key. Refer to Figure 3-5 during the following menu and screen descriptions.

NOTE

To edit a screen value, press ENTER to access the data field. Use the left and right arrow keys to move among the digits in the data field. Note that the editable position will be flashing. To change the value of a digit, use the up and down arrow keys to increase or decrease the value. When finished editing, press ENTER to accept the value. To go to the next screen in the menu, press NEXT.

Operator Adjustable Parameters

Figure 3-1 lists the range and default value of operator-adjustable variables used by the Rosemount 5081 transmitter. Each of these variables may be adjusted using the PROGRAM MENU screens.

Table 3-1. Adjustatble Parameters

Parameter	Function	Range	Factory Default
CODE	Use to enter the access code for this analyzer; select 555 to display designated analyzer code	000 - 999 (excluding 000 and 555)	000 (no code)
FAULT VAL	Use to designate a 4-20mA value that when displayed will indicate an analyzer-faulted condition	3.8mA - 24mA	3.6mA
UPPER RANGE VAL	Use to set upper O ₂ % limit equivalent to 20mA output (adjust the slope of the analyzer)	2.0% - 25.0%	25%
CELL T HI	Use to set upper cell temperature for no-fault condition	650°C - 1600°C	1600°C
SET O2 FILTER TIME	Use to adjust analyzer response time to changing O ₂ %	0 - 300 seconds	0 seconds
SET HI BOTTLE O2	Use to define actual O ₂ % of high calibration check gas		8%
SET LO BOTTLE O2	Use to define actual O ₂ % of low calibration check gas		2%
SET CODE	Use to set security code for this analyzer	000 - 999 (excluding 000 and 555)	000 (no code)

Rosemount 5081FG

Code

Refer to Figure 3-7. After pressing the PROG key, this screen will display if security is enabled (see Set Code). Use this screen to identify a specific analyzer in a process to prevent accessing an adjacent analyzer when using the IRC.

Press ENTER to begin editing. At this point, you can either specify the analyzer by its access code or view its code if it is unknown.

1. To gain further access to the screens in the PROGRAM MENU branch, enter the correct three-digit analyzer access code using the arrow keys and press ENTER. If security is disabled, this screen does not appear and the system displays the FAULT VAL screen.
2. If the analyzer access code is un-known, enter 555 and press ENTER to access the DISPLAY CODE screen. In that screen you will be able to view the analyzer access code.

Figure 3-7. Code

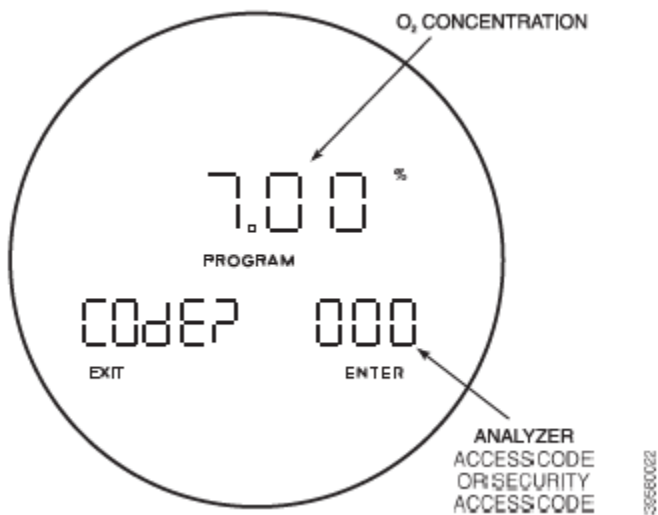

Display Code

Refer to Figure 3-8. This screen is accessible from the CODE screen by entering 555 and pressing ENTER. The DISPLAY CODE screen identifies the analyzer access code so you can return to the CODE screen and enter the code as described in Code. To return to the CODE screen, press NEXT.

Fault Val

Refer to Figure 3-9. Use this screen to set the value that the 4-20mA output will drive to and display during a fault condition. Press ENTER to begin editing. Use the arrow keys to enter a fault value. The fault value can be between 3.8 and 24 mA. Then, press ENTER to accept the value. Pressing NEXT displays the UPPER RANGE VAL screen. Refer to Section 5: Troubleshooting, for the actual fault conditions.

Figure 3-8. Display Code

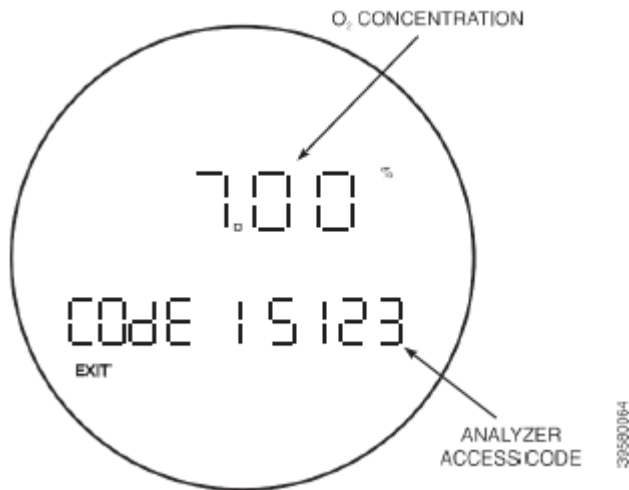
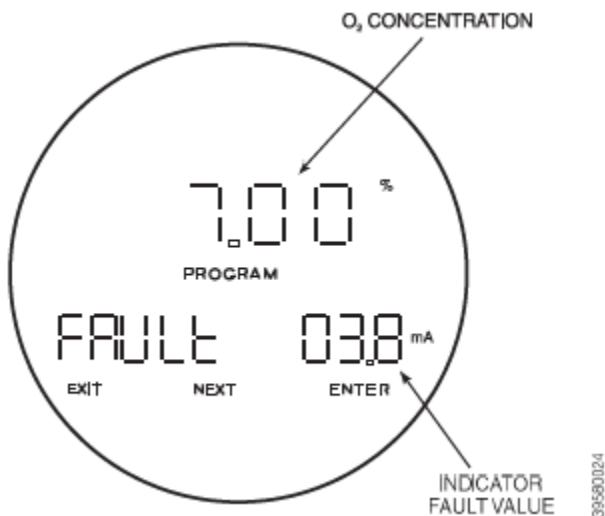

Figure 3-9. Fault Val



Rosemount 5081FG

Upper Range Val

Refer to Figure 3-10. Use this screen to set the value of the upper range limit. This value is the maximum limit of the O₂ concentration measurement and is used to scale the 4-20 mA output. Press ENTER to begin editing. Use the arrow keys to select and change the value. The upper range value can be between 0 and 25%. Then, press ENTER to accept the value. Pressing NEXT displays the CELL T HI screen.

Cell T Hi

Refer to Figure 3-11. Use this screen to set the value of the upper cell temperature fault condition. This value is the maximum allowed cell temperature before a fault condition is indicated. Press ENTER to begin editing. Use the arrow keys to select and change the value. The value must be between 550°C and 1600°C. Press ENTER to accept the value. Pressing NEXT displays the RESET MAX CELL T screen.

Figure 3-10. Upper Range Val

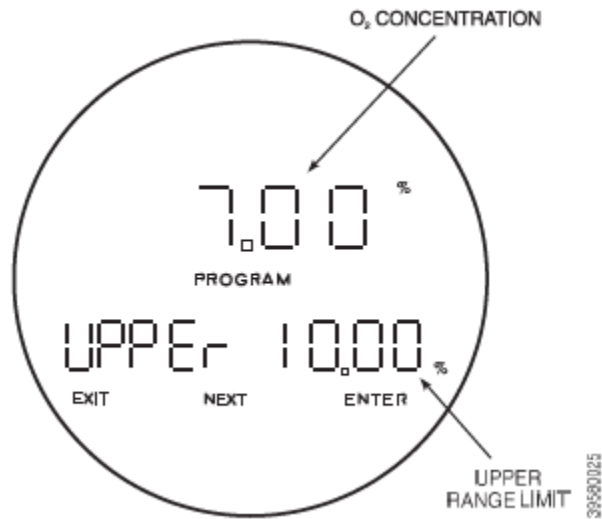
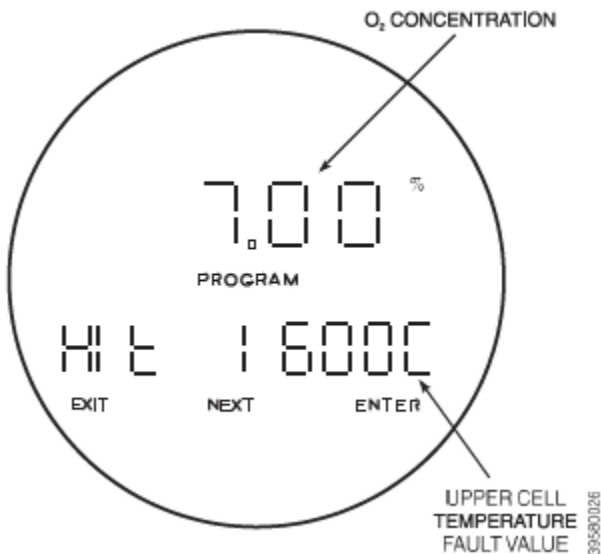

Figure 3-11. Cell T Hi



Reset Max Cell T

Refer to Figure 3-12. The transmitter tracks the maximum cell temperature obtained. Use this screen to reset the maximum cell temperature attained value to the current cell temperature. Press ENTER to begin editing. Use the arrow keys to select and change the value (Y/N). Then, press ENTER to accept the value. Pressing NEXT displays the SET O₂ FILTER TIME screen.

Set O₂ Filter Time

Refer to Figure 3-13. In some applications it is beneficial to dampen the raw O₂ signal coming from the cell. Use this screen to enter the amount of time it will take the O₂ to reach 90% of the new reading. Press ENTER to begin editing. Use the arrow keys to select and change the screen value to the O₂ filter value (in seconds). Enter a value between 0 and 300 seconds and press ENTER to accept the value. Press NEXT to access the TRIM 4 mA? screen.

Figure 3-12. Reset Max Cell T

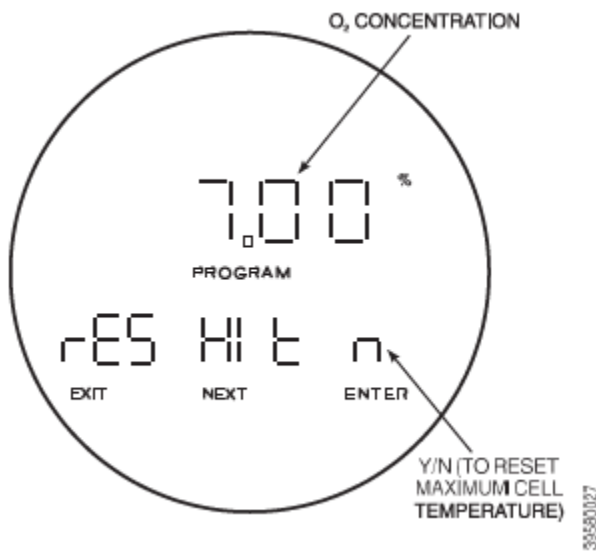
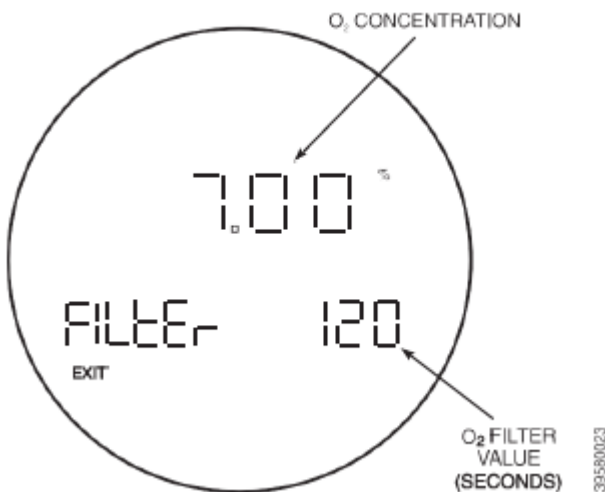

Figure 3-13. Set O₂ Filter Time



Rosemount 5081FG

Trim 4mA

Refer to Figure 3-14. Use this screen to trim the 4 mA value of the 4-20 mA output.

NOTE

Before trimming the 4 mA value you must break the loop to add the ammeter. Power down the unit, connect the ammeter in series with Rosemount 5081 transmitter terminals 15(-) and 16(+), power up the unit, and return to the TRIM 4 mA screen.

Press ENTER to begin editing. Use the arrow keys to select and change the screen value to the value displayed on the installed ammeter. Press ENTER to accept the value. After the value is entered, the unit calibrates itself to ensure it outputs 4 mA. Both the display and the ammeter will display 4 mA. Pressing EXIT returns to the initial TRIM 4 mA screen, and pressing NEXT displays the TRIM 20 mA? screen.

Figure 3-14. Trim 4mA

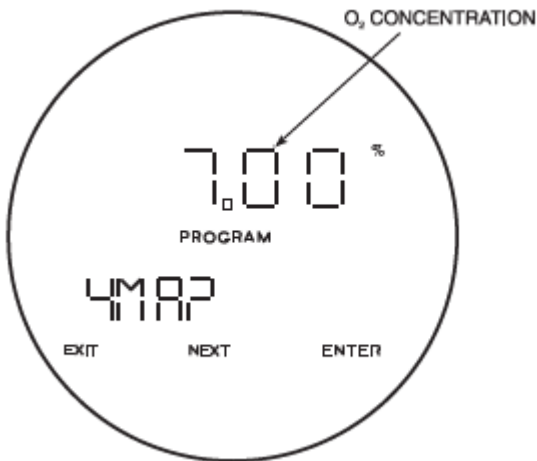

Trim 20mA

Refer to Figure 3-15. Use this screen to trim the 20 mA value of the 4-20 mA output.

NOTE

Before trimming the 20 mA value you must break the loop to add the ammeter. Power down the unit, connect the ammeter in series with Rosemount 5081 transmitter terminals 15(-) and 16(+), power up the unit, and return to the TRIM 20 mA screen.

Press ENTER to begin editing. Use the arrow keys to select and change the screen value to the value displayed on the installed ammeter. Press ENTER to accept the value. After the value is entered, the unit calibrates itself to ensure it outputs 20 mA. Both the display and the ammeter will display 20 mA. Pressing EXIT returns to the initial TRIM 20 mA screen, and pressing NEXT displays the SET HI BOTTLE O₂ screen.

Figure 3-15. Trim 20mA

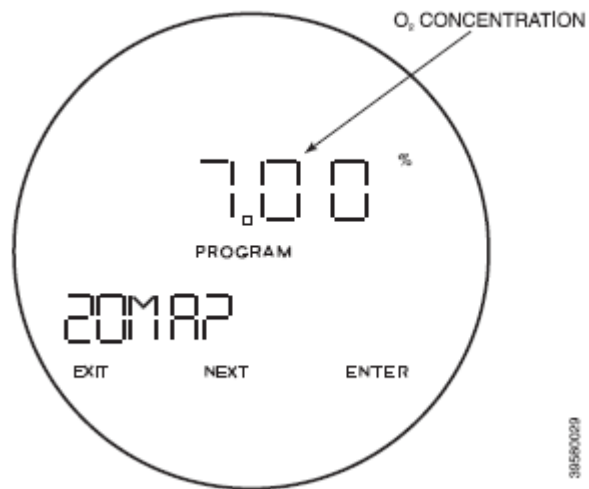

381580029

Rosemount 5081FG

Set Hi Bottle O₂

Refer to Figure 3-16. Use this screen to identify, within the electronics, the percentage of O₂ used as the high calibration check gas. Press ENTER to begin editing. Use the arrow keys to select and change the screen value to the O₂ percentage of the high calibration check gas. Press ENTER to accept the value.

Set Lo Bottle O₂

Refer to Figure 3-17. Use this screen to identify, within the electronics, the percentage of O₂ used as the low calibration check gas. Press ENTER to begin editing. Use the arrow keys to select and change the screen value to the O₂ percentage of the low calibration check gas. Press ENTER to accept the value. Press NEXT to display the SET O₂ TRACKING screen.

Figure 3-16. Set Hi Bottle O₂

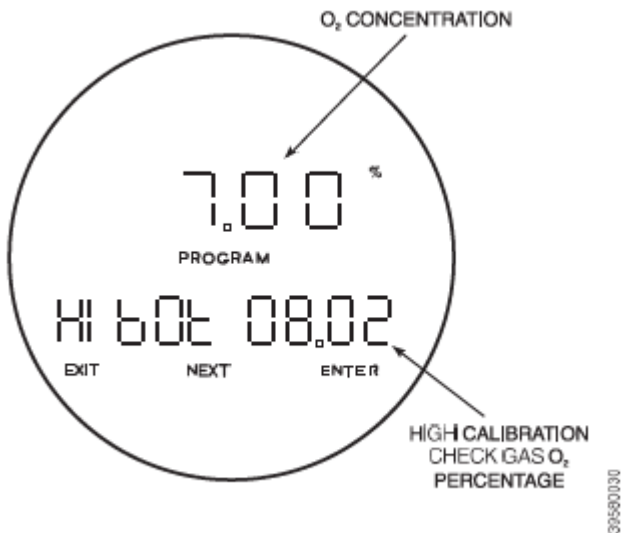
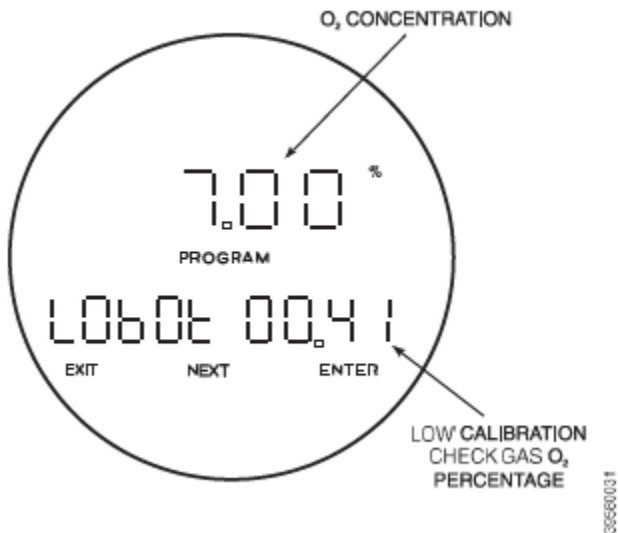

Figure 3-17. Set Lo Bottle O₂



Set O₂ Tracking

Refer to Figure 3-18. Use this screen to permit the 4-20 mA line to track the O₂ value during a calibration check. Press ENTER to begin editing. Use the arrow keys to select Y or N. Entering Y (yes) will allow the 4-20 mA line to track the O₂ value during the calibration check. Entering N (no) will hold the O₂ value steady during the calibration check. Press ENTER to accept the value. Press NEXT to display the SET CODE screen.

Set Code

Refer to Figure 3-19. Use this screen to set the security code for the Rosemount 5081 transmitter. Press ENTER to begin editing. Use the arrow keys to select and change the value. Select any value between 000 and 999, excluding 000 and 555. Code 000 indicates that no code is set. Code 555 accesses the DISPLAY CODE screen. Press ENTER to accept the value. Pressing NEXT returns to the FAULT VAL screen at the beginning of the PROGRAM MENU.

Figure 3-18. Set O₂ Tracking

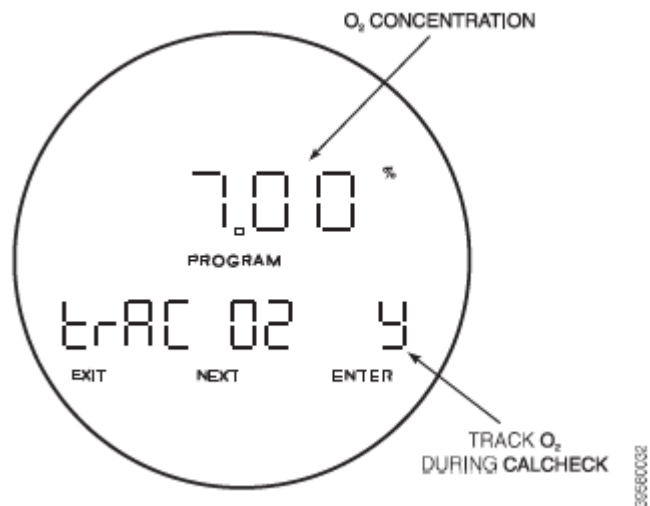

Rosemount 5081FG

Figure 3-19. Set Code

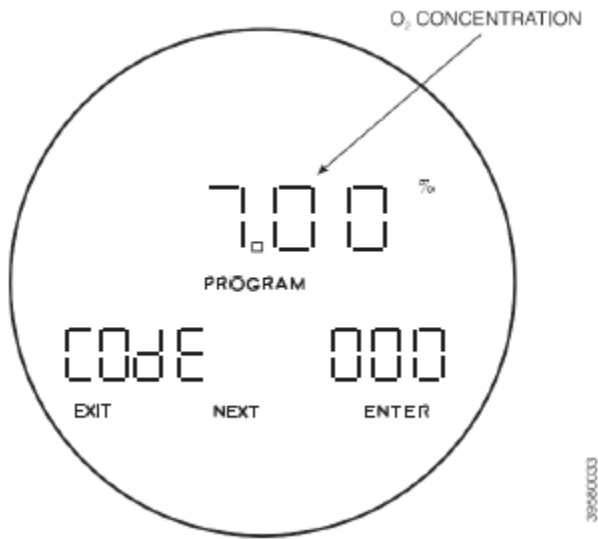

DIAGNOSTICS MENU

The DIAGNOSTICS MENU branch of the menu tree allows you to examine outputs, current faults, and unit information. None of the items in the DIAGNOSTICS MENU are editable. This branch of the menu tree may be accessed by pressing DIAG on the IRC when in the PROCESS DISPLAY screen (Normal or Faulted). Each screen in this branch is accessed sequentially by pressing NEXT. Refer to the menu in Figure 3-5 when reviewing the following menu and screens.

Show Fault

Refer to Figure 3-20. After pressing DIAG, this screen displays. Pressing ENTER accesses a screen displaying the current fault (if any). If more than one fault exists, and you are in the FAULT screen, press NEXT to go to the next fault. Information on the fault screens can be found in Section 5: Troubleshooting. Press EXIT to return from this fault sub-menu and press NEXT to access the T/C mV screen.

Figure 3-20. Show Fault



30660034

Rosemount 5081FG

T/C mV

Refer to Figure 3-21. Use this screen to examine the cell thermocouple mV output. Three decimal places are displayed. Pressing NEXT accesses the O₂ CELL mV screen.

O₂ CELL mV

Refer to Figure 3-22. Use this screen to examine the O₂ CELL mV output. Pressing NEXT accesses the CELL IMPEDANCE screen.

Figure 3-21. T/C mV

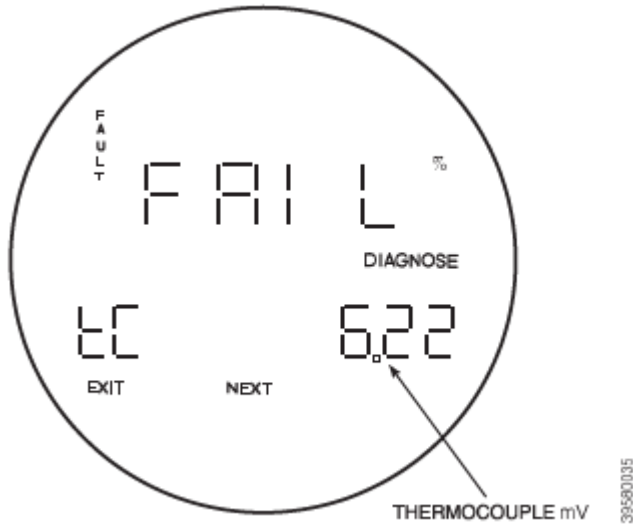
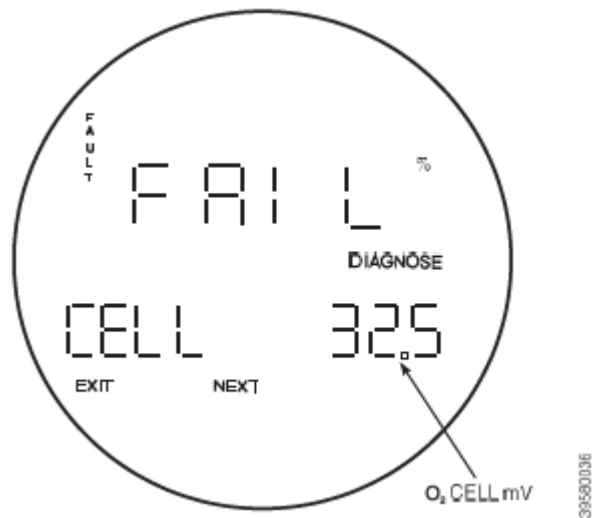

Figure 3-22. O₂ CELL mV



Cell Impedance

Refer to Figure 3-23. Use this screen to examine the O₂ cell impedance status. GOOD indicates the cell is operating normally. WARN indicates the cell has degraded but is still operational. HI indicates that the cell has degraded but is still operational; however, failure will occur soon. Pressing NEXT accesses the CURRENT SLOPE screen.

NOTE

Temperature influences cell impedance. Wait until the cell is at operating temperature before checking cell impedance. If checked before the cell reaches 550°C (1022°F), this screen displays a fail indication.

Current Slope

Refer to Figure 3-24. Use this screen to examine the slope calculated from the most recent calibration check. The slope is the amount of cell voltage generated for a given O₂ value. For each calibration check, record the slope over the life of the probe. Tracking the slope will indicate if the probe is degrading. Press NEXT to access the CURRENT CONSTANT screen.

Figure 3-23. Cell Impedance

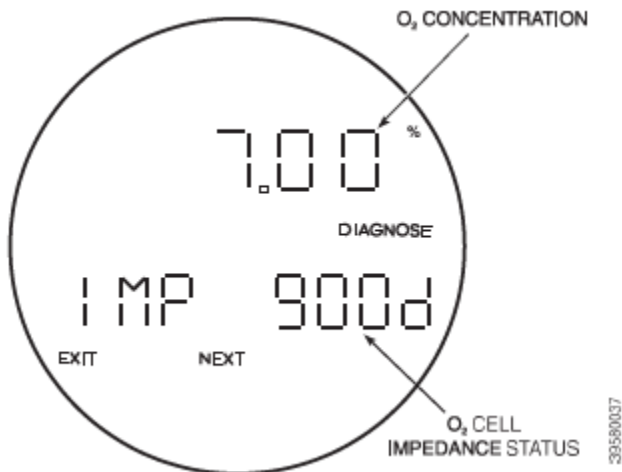
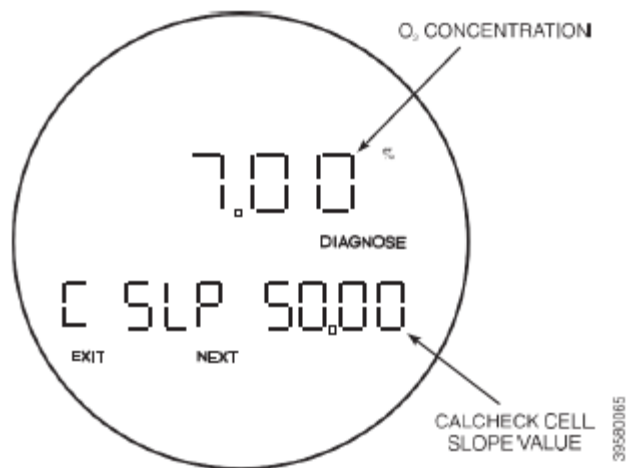

Figure 3-24. Current Slope



Rosemount 5081FG

Current Constant

Refer to Figure 3-25. Use this screen to examine the cell zero constant calculated from the most recent calibration check. The constant represents the voltage generated by the cell when no difference exists between the amount of O₂ on the reference and process sides of the cell. Press NEXT to access the PREVIOUS SLOPE screen.

Previous Slope

Refer to Figure 3-26. Use this screen to examine the slope value stored from the second to last calibration check. The slope is the amount of cell voltage generated for a given O₂ value. For each calibration check, record the slope over the life of the probe. Tracking the slope will indicate if the probe is degrading. Press NEXT to access the PREVIOUS CONSTANT screen.

Figure 3-25. Current Constant

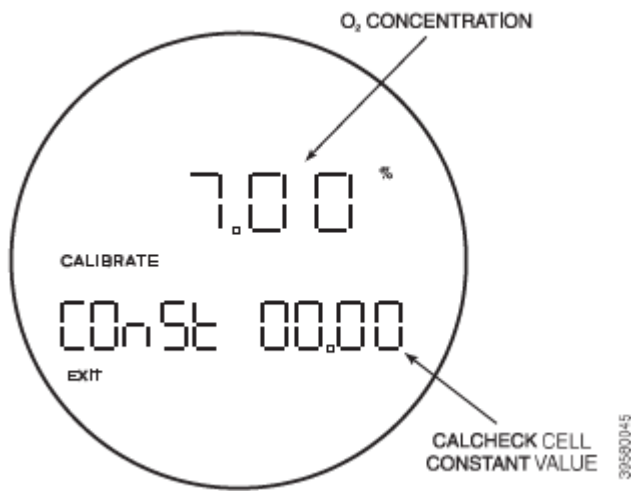
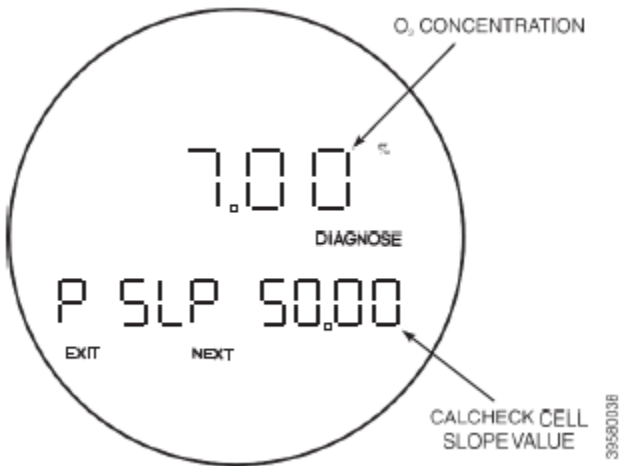

Figure 3-26. Previous Slope



Previous Constant

Refer to Figure 3-27. Use this screen to examine the cell zero constant stored from the second to last calibration check. The constant represents the voltage generated by the cell when no difference exists between the amount of O₂ on the reference and process sides of the cell. Press NEXT to access the MAX CELL T screen.

Max Cell T

Refer to Figure 3-28. Use this screen to examine the maximum temperature attained by the O₂ cell. This value can be reset under the PROGRAM MENU. Pressing NEXT accesses the SW VER screen.

Figure 3-27. Previous Constant

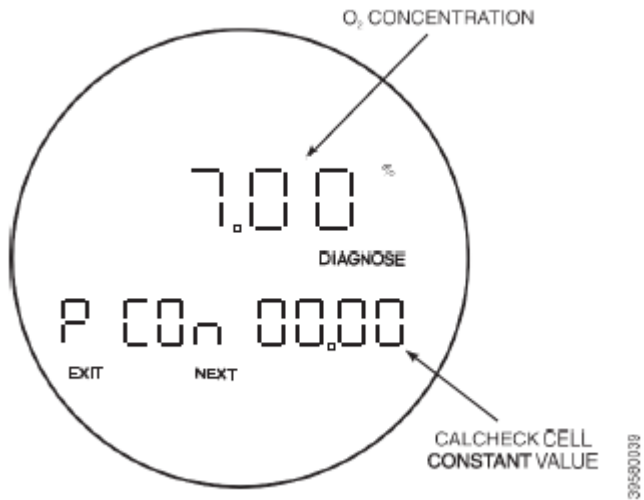
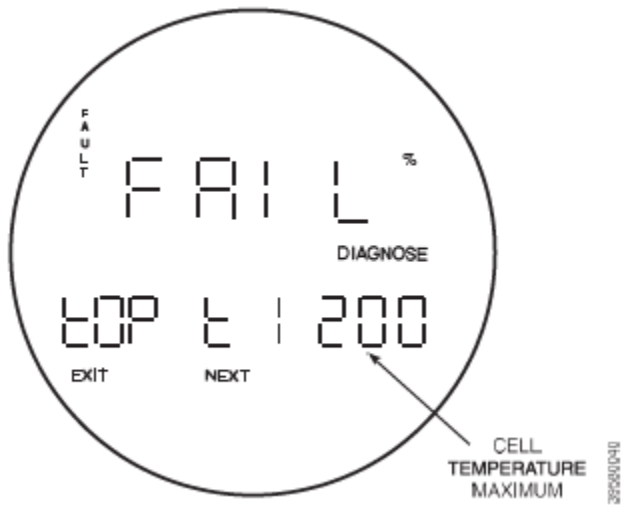

Figure 3-28. Max Cell T



Rosemount 5081FG

- SW Ver (SOft)** Use this screen to see the software version number for the Rosemount5081 transmitter. Pressing NEXT accesses the UNIT SER # screen.
- Unit Ser # (SEr)** Use this screen to see the unit serial number for the Rosemount5081 transmitter. Pressing NEXT accesses the SW BUILD NUMBER screen.
- SW Build Number (bLdn)** Use this screen to see the software build number for the Rosemount5081 transmitter. Pressing NEXT accesses the SW BUILD DATE screen.
- SW Build Date (bd)** Use this screen to see the software build date for the Rosemount5081 transmitter. Pressing NEXT returns to the beginning of the DIAGNOSTICS MENU branch (the SHOW FAULT screen).

CAL CHECK MENU

The CALCHECK MENU branch of the menu tree (Figure 3-5) allows you to perform a calibration check of the analyzer. Before performing a calibration check, ensure the high calibration check gas and low calibration check gas O₂ percentages are entered into the electronics via the PROGRAM MENU. To set these values, refer to Set Hi Bottle O₂ and Set Lo Bottle O₂.

Once these values are set, access the CAL-CHECK MENU branch by pressing CAL on the IRC when in the PROCESS DISPLAY screen (Normal or Faulted). Each screen in this branch identifies a process step in the calibration check procedure. The first screen in the sequence is the IN MANUAL? screen.

In Manual?

⚠ WARNING

Failure to remove the analyzer from automatic control loops prior to performing this procedure may result in a dangerous operating condition.

Refer to Figure 3-29. If the O₂ output value is used in any automatic process control loops the loop must be placed in manual to begin a calibration check.

Once the analyzer is removed from any automatic control loops press ENTER to edit the screen. Use the arrow keys to select Y (yes); press ENTER to start a calibration check and to display the ACCEPTHIGH O₂ screen.

Figure 3-29. In Manual?

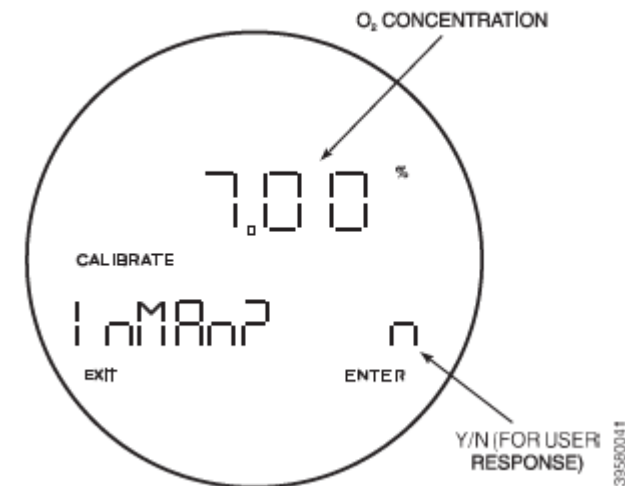

Accept High O₂

Refer to Figure 3-30. After pressing ENTER to begin the calibration check, the high calibration check gas starts to flow. After waiting approximately three minutes for the displayed O₂ value to settle, press NEXT to accept the high calibration check gas reading and apply the low calibration check gas. The next screen to display is the ACCEPT LOW O₂ screen.

Accept Low O₂

Refer to Figure 3-31. Once the low calibration check gas is applied, wait approximately three minutes for the displayed O₂ value to settle. Once the value settles, press NEXT to accept the reading and to display the SLOPE screen.

Figure 3-30. Accept High O₂

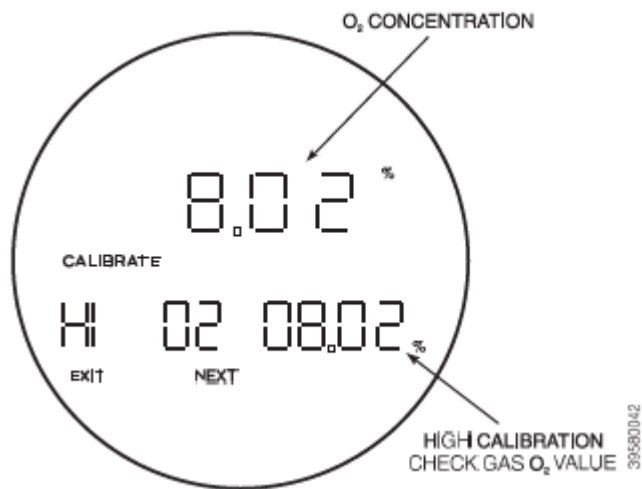
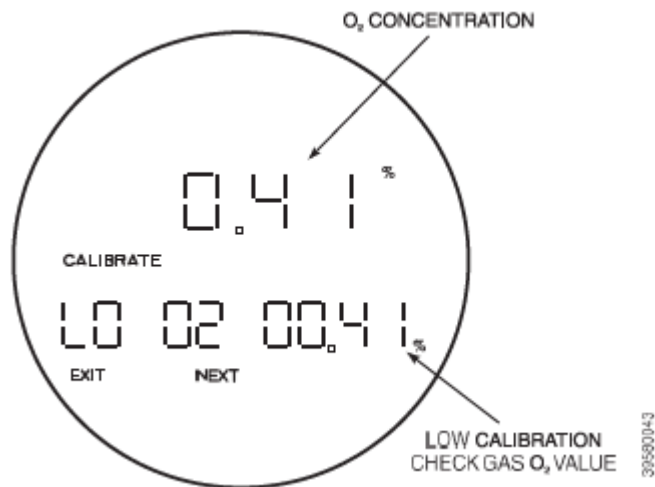

Figure 3-31. Accept Low O₂



Rosemount 5081FG

Slope

Refer to Figure 3-32. Use this screen to examine the slope calculated from current calibration check. The slope is the amount of cell voltage generated for a given O₂ value. After each calibration check, record the slope over the life of the probe. Tracking the slope will indicate if the probe is degrading. Press NEXT to access the CONSTANT screen.

Constant

Refer to Figure 3-33. Use this screen to examine the cell zero constant calculated from the current calibration check. The constant represents the voltage generated by the cell when no difference exists between the amount of O₂ on the reference and process sides of the cell. Note this value for comparison against future calibration checks. Press RESET or EXIT to return to the PROCESS DISPLAY screen.

Figure 3-32. Slope

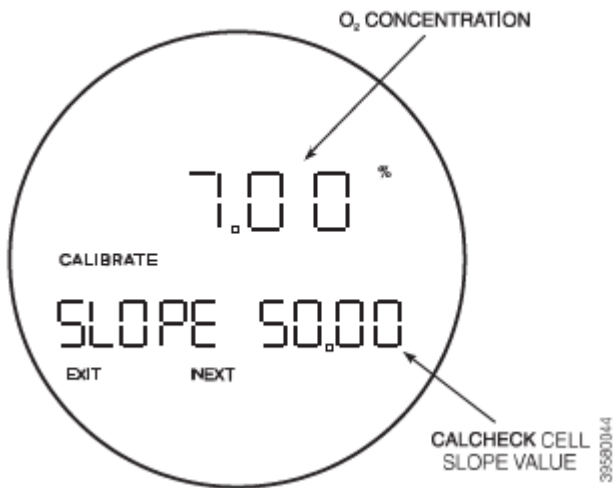
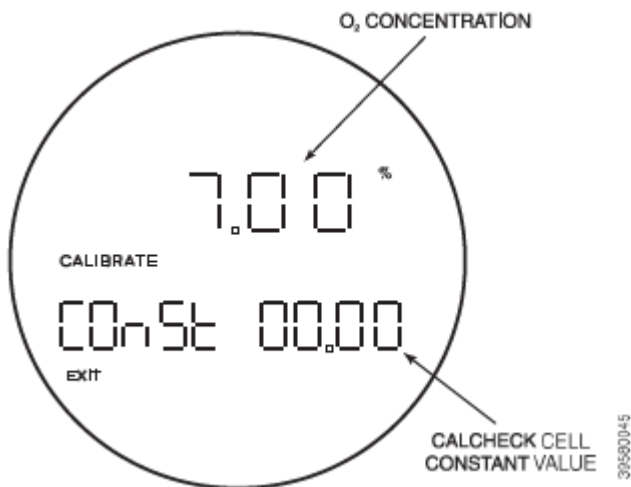

Figure 3-33. Constant



Section 4 HART/AMS

Overview	page 4-1
Field Communicator Signal Line Connections	page 4-2
Field Communicator PC Connections	page 4-4
Off-Line and On-Line Operations	page 4-4
HART/AMS Menu Tree	page 4-4
Field Communicator Start Cal Check Method	page 4-8

OVERVIEW

The HART field communicator is a hand-held communications interface device. It provides a common communications link to all microprocessor-based instruments that are HART compatible. The field communicator has a liquid crystal display (LCD) and keypad. A pocket-sized manual, included with the field communicator, details the specific functions of the keypad keys.

To interface with the Rosemount 5081FG Analyzer, the field communicator requires a termination point along the 4-20 mA current loop and a minimum load resistance of 250 ohms between the field communicator and the power supply.

The field communicator accomplishes its task using a frequency shift keying (FSK) technique. With the use of FSK, high-frequency digital communication signals are superimposed on the analyzer's 4-20 mA current loop. The field communicator does not disturb the 4-20 mA signal, since no net energy is added to the loop.

The field communicator may be interfaced with a personal computer (PC), providing that special software has been installed. To connect the field communicator to a PC, an interface adapter is required. Refer to the proper field communicator documentation regarding the PC interface option.

FIELD COMMUNICATOR SIGNAL LINE CONNECTIONS

The field communicator can connect to the analyzer's analog output signal line at any wiring termination in the 4-20 mA current loop. There are two methods of connecting the field communicator to the signal line. For applications in which the signal line has a load resistance of 250 ohms or more, refer to method 1. For applications in which the signal line load resistance is less than 250 ohms, refer to method 2.

Method 1, For Load Resistance 250 Ohms

Refer to Figure 4-1 and the following steps to connect the field communicator to a signal line < 250 ohms or more of load resistance.

⚠ WARNING

Explosions can result in death or serious injury. Do not make connections to the field communicator's serial port, 4-20 mV signal line, or NiCad recharger jack in an explosive atmosphere.

Using the supplied lead set, connect the field communicator in parallel with to the Rosemount 5081FG Analyzer. Use any wiring termination points in the analog output 4-20 mA signal line.

Figure 4-1. Signal Line Connections, 250 Ohms Load Resistance

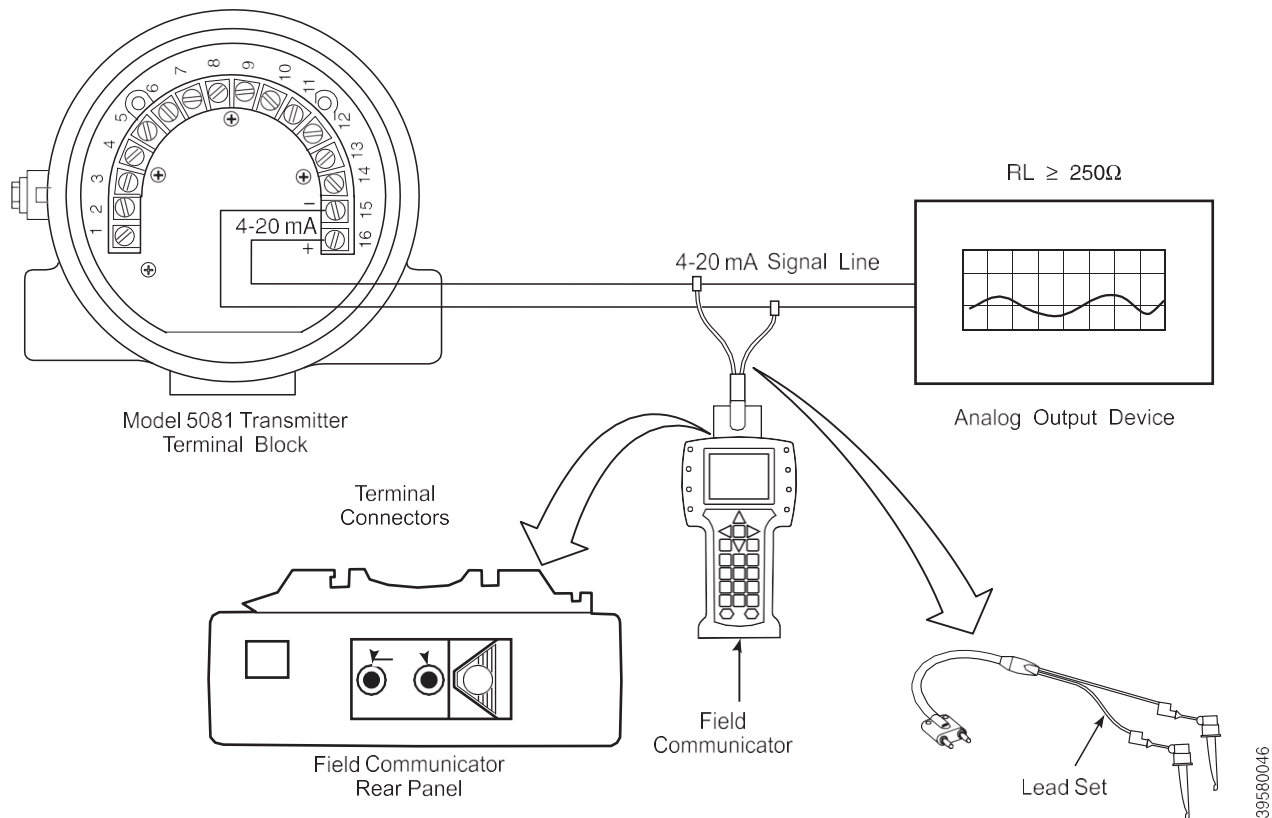

39580046

Method 2, For Load Resistance < 250 ohms

Refer to Figure 4-2 and the following steps to connect the field communicator to a signal line with < 250 ohms load resistance.

⚠ WARNING

Explosions can result in death or serious injury. Do not make connections to the field communicator's serial port, 4-20 mA signal line, or NiCad recharger jack in an explosive atmosphere.

1. At a convenient point break the analog output 4-20 mA signal line and install the optional 250 ohm load resistor.
2. Plug the load resistor into the rear panel of the field communicator.

Figure 4-2. Signal Line Connections, < 250 Ohms Load Resistance

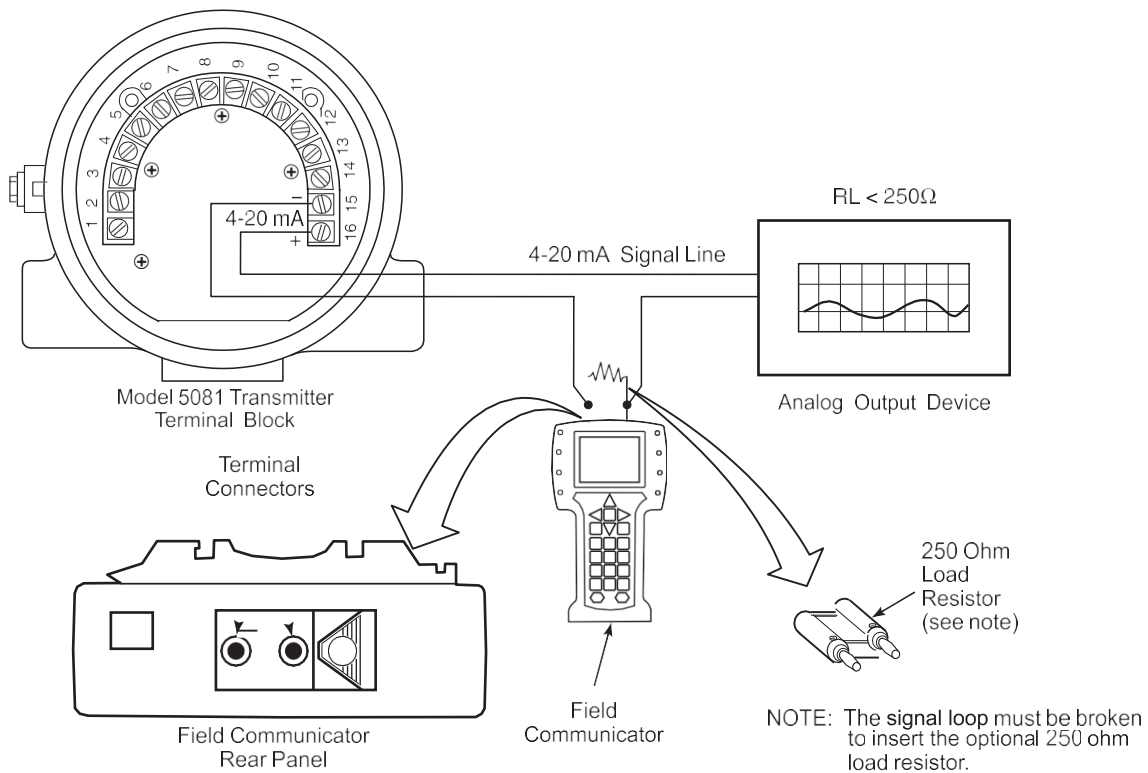

39560047

Rosemount 5081FG

FIELD COMMUNICATOR PC CONNECTIONS

There is an option to interface the field communicator with a personal computer. Refer to the applicable field communicator documentation regarding the PC interface option.

OFF-LINE AND ON-LINE OPERATIONS

The field communicator can be operated both off-line and on-line.

Off-line operations are those in which the communicator is not connected to the Rosemount 5081FG Analyzer. Off-line operations can include interfacing the field communicator with a PC (refer to applicable HART documentation regarding HART/PC applications).

In the on-line mode, the communicator is connected to the 4-20 mA analog output signal line. The communicator is connected in parallel to the Rosemount 5081FG Analyzer or in parallel to the 250 ohm load resistor.

NOTE

If the field communicator is turned on while connected to the 4-20 mA analog output signal line, an undefined status indication appears while the communicator warms up. Wait until the warm-up period ends to continue.

The opening menu displayed on the LCD is different for on-line and off-line operations. When powering up a disconnected (off-line) communicator, the LCD will display the Main Menu. When powering up a connected (on-line) communicator, the LCD will display the On-line Menu. Refer to the field communicator manual for detailed menu information.

HART/AMS MENU TREE

This section consists of a menu tree for the field communicator. This menu is specific to Two-Wire In-Situ Oxygen Analyzer applications.

Figure 4-3. HART/AMS Menu Tree (Sheet 1 of 3)

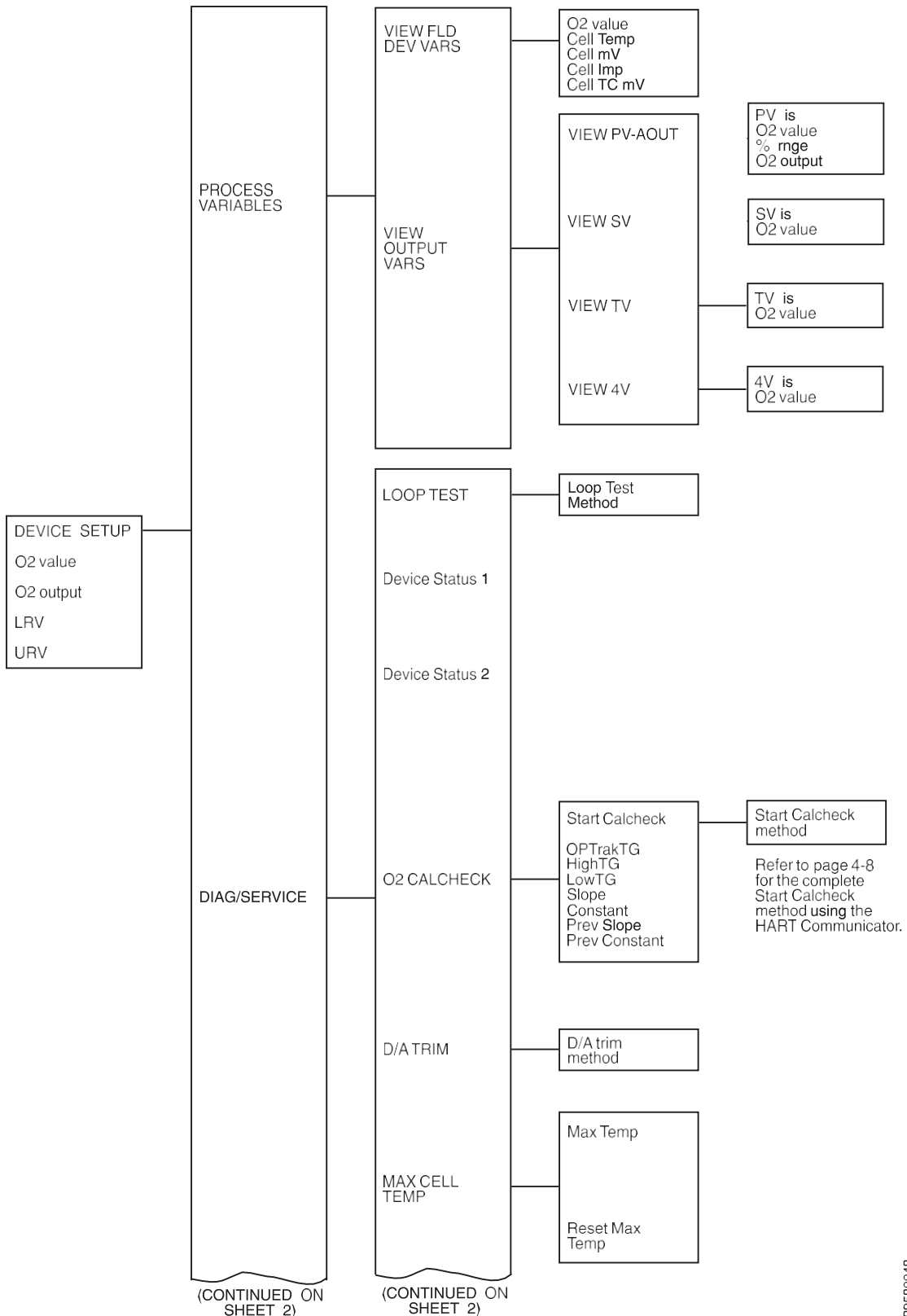
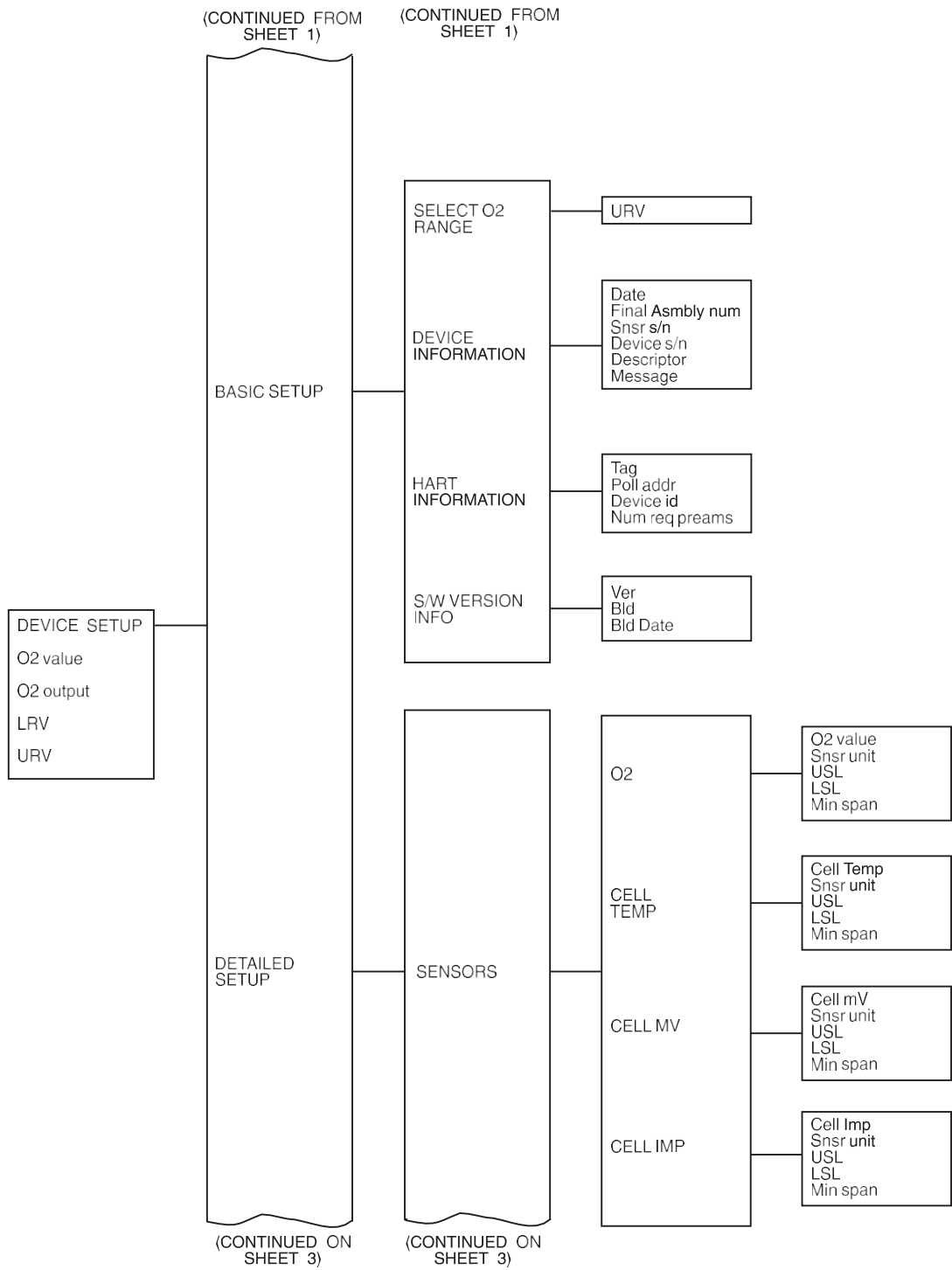
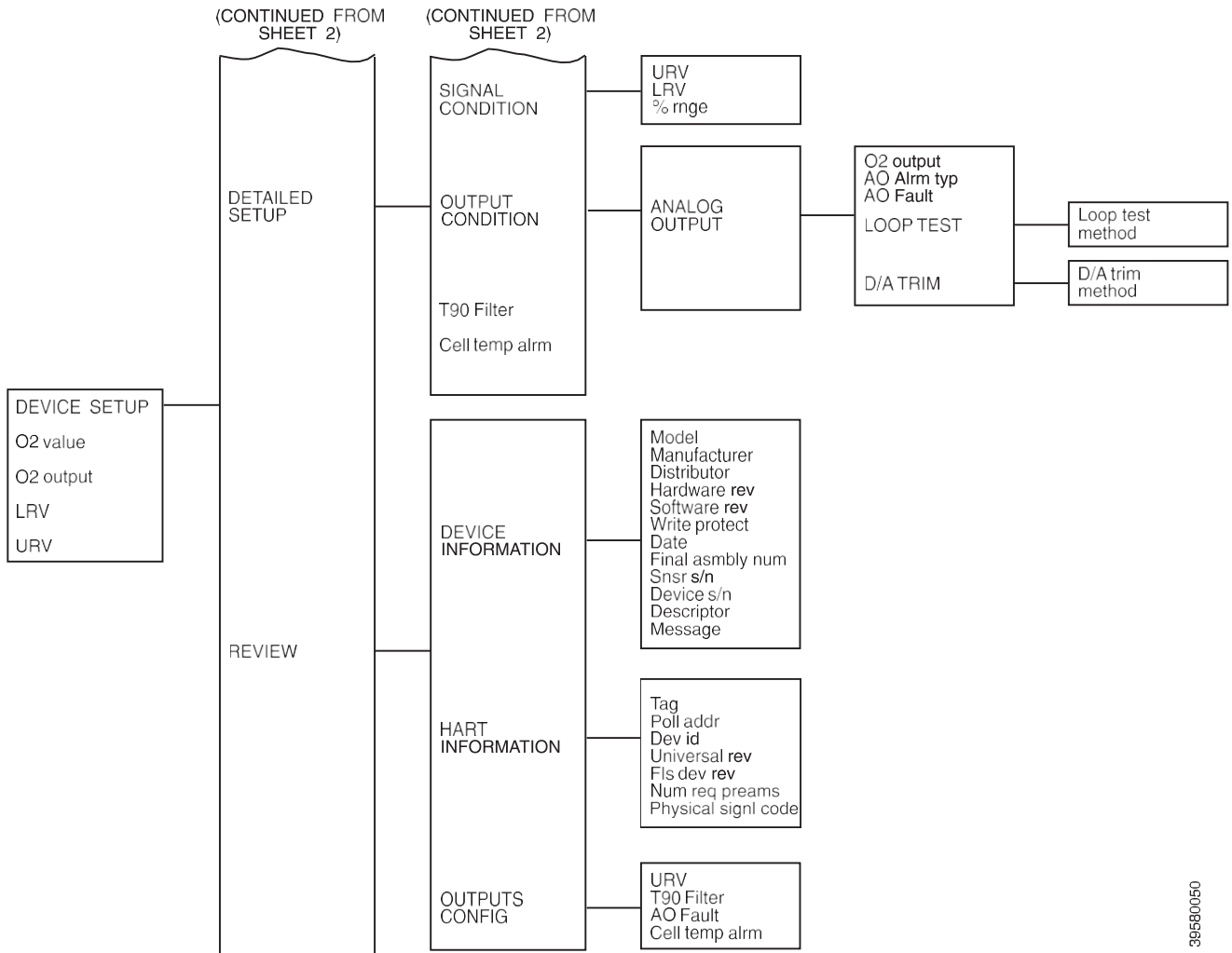

Figure 4-3. HART/AMS Menu Tree (Sheet 2 of 3)



39560049

Figure 4-3. HART/AMS Menu Tree (Sheet 3 of 3)



39580050

FIELD COMMUNICATOR START CAL CHECK METHOD

To perform a calibration check on the Two-Wire In-Situ Oxygen Analyzer with the field communicator, use the following procedure. If necessary, use the menu tree in Figure 4-3 (sheet 1 of 3) for reference.

NOTE

To select a menu item use either the up and down arrow keys to scroll to the menu item. Press the right arrow key or use the number keypad to select the menu item number. To return to a preceding menu, press the left arrow key.

NOTE

Pressing ABORT at any time during this process will purge the calibration check gases and end the calibration check procedure.

1. From the DEVICE SETUP SCREEN, select DIAG/SERVICE.
2. From the DIAG/SERVICE screen, select O₂ CALCHECK.
3. Before starting the calibration check procedure, first set up the high calibration check gas, low calibration check gas, and tracking using HART/AMS.
4. From the O₂ CALCHECK screen, select menu item 1, START CALCHECK, to access the calibration check procedure.

WARNING

Failure to remove the analyzer from automatic control loops prior to performing this procedure may result in a dangerous operating condition.

5. In the first screen, a "Loop should be removed from automatic control" warning appears. Remove the analyzer from any automatic control loops to avoid undesirable equipment performance and press OK.
6. The next screen prompts you to apply the high calibration check gas. This message will only display for approximately three seconds. Press OK.
7. At this point, calibration check gas will flow for approximately three minutes until the gas reading is taken. Once the gas is measured, the message, "Hi gas reading taken," displays for three seconds.
8. Next, the screen prompts you to apply the low calibration check gas. Press OK.
9. The low calibration check gas will flow for approximately three minutes until the reading is taken. Once the gas is measured, the message, "Low gas reading taken," displays for three seconds.
10. Next, the screen prompts you to disconnect the calibration check gases. Press OK. Once the gases are disconnected the system will purge the gases for approximately three minutes.
11. When the "Loop may be returned to automatic control" note appears, return the analyzer to the automatic control loops previously removed and press OK.

Section 5 Troubleshooting

General	page 5-1
Probe Life	page 5-1
Fault Indications	page 5-3
Identifying And Correcting Fault Indications	page 5-4
Calibration Passes, But Still Reads Incorrectly	page 5-8

GENERAL

This troubleshooting section describes how to identify and isolate faults that may develop in the Two-Wire In-Situ Oxygen Analyzer.

PROBE LIFE

The zirconium oxide technology for measuring oxygen is very stable and should provide accurate service for several years.

Life of the probe is negatively impacted by:

- Continued operation at elevated temperatures above 1300°C (2372°F).
- Operation in processes that contain high levels of sulfur, SO₂, or other acidic compounds.

Operating conditions with simultaneously high levels of SO₂ and low levels of O₂ are particularly damaging.

The health and accuracy of a given cell is closely related to the resistance, or impedance, of the cell. Figure 5-1 illustrates that the amount of output from a cell for a given O₂ value (represented as slope) will remain very stable to the point where cell impedance increases to approximately 100 ohms.

Frequently conduct calibration checks to look for the following conditions:

- Continued degradation of cell slope.
- Sluggish response. (Note how long it takes the cell to respond to the application of calibration check gases.) See Figure 5-2.

The slope will be valid only for the process temperature at which the calibration check gases are flowed, so no adjustments to the electronics are made as a result of a calibration check.

Note that cells exposed to temperatures above 1300°C (2372°F) may lose the ability to measure accurately and respond quickly when returned to the lowest end of the operating temperature range [550°C (1022°F)].

Figure 5-1. Slope vs. Impedance

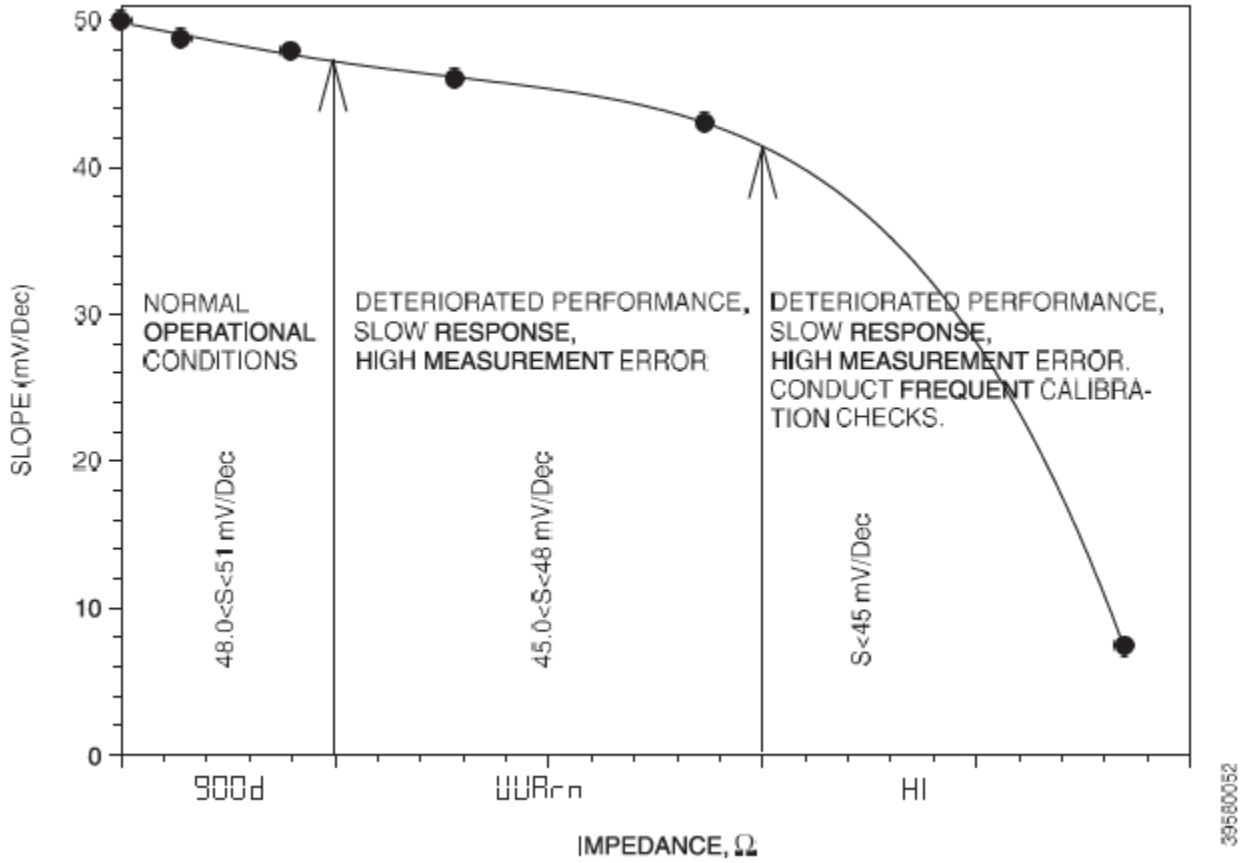
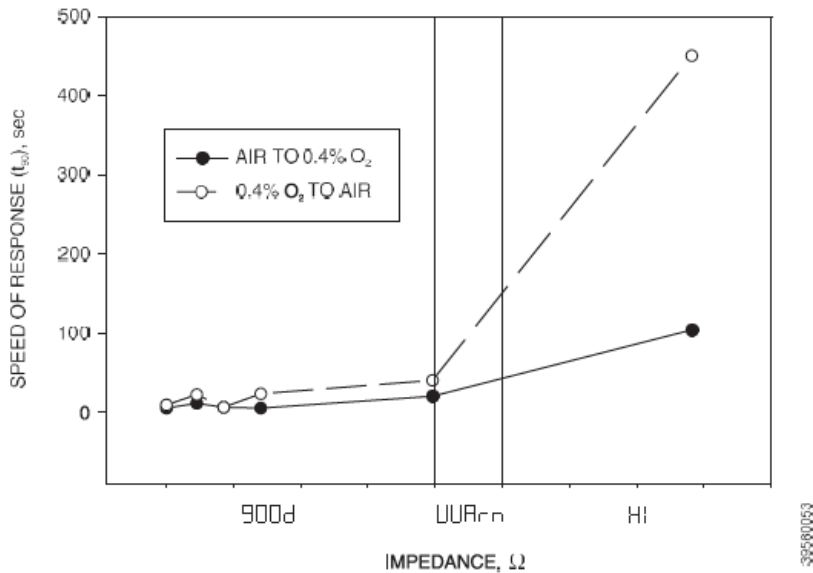

Figure 5-2. Speed of Response



FAULT INDICATIONS

The fault conditions for the Two-Wire In-Situ Oxygen Analyzer will be indicated by the faulted operation display as shown in Figure 5-3. This screen displays when a fault that invalidates the O₂ reading is present. When the error is corrected, the screen will return to a normal operation display unless another error exists.

Figure 5-3. Faulted Operation Display



IDENTIFYING AND CORRECTING FAULT INDICATIONS

A fault in the operation of the Two-Wire In-Situ Oxygen Analyzer is indicated by the faulted operation display. If no faults exist the display will indicate NONE. Information on the current fault is found under the DIAGNOSTICS MENU as detailed in Section 3: Startup and Operation.

The following paragraphs describe the faults, possible causes, and corrective actions. Refer to Figure 5-4 as needed for test points and wiring information.

NOTE

Allow adequate time for the oxygen probe to reach its operating temperature [approximately 500°C (932°F)] before investigating a fault. The SHOW FAULTS screen of the DIAGNOSTICS menu will indicate a fault until the unit reaches operating temperature.

NOTE

The probe uses a Type B thermocouple to measure the cell temperature. A Type B thermocouple output table may be useful for troubleshooting.

Figure 5-4. Transmitter Terminal Block

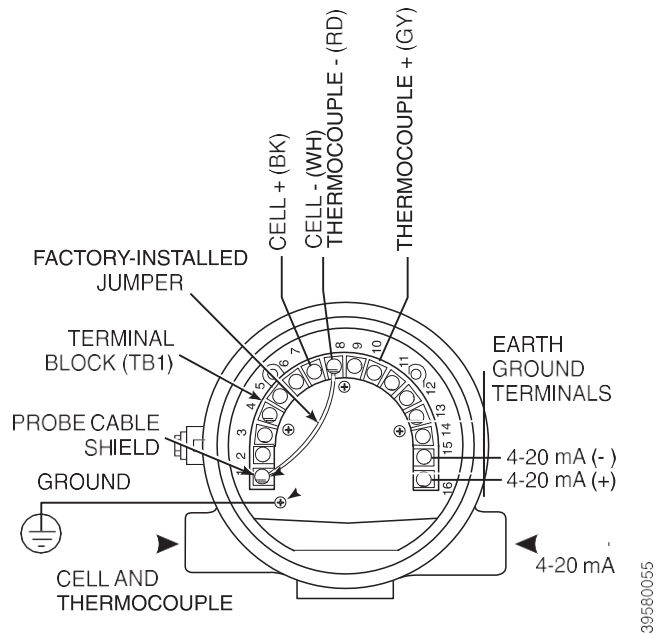

Figure 5-5. Fault 1, Open Thermocouple



Fault 1, Open Thermocouple

The thermocouple connection is open. The fault displays as shown in Figure 5-5.

1. Refer to Figure 5-4 and check the thermocouple wiring connections at terminals 8 and 10. Ensure the wires are properly connected.
2. Remove power. Disconnect the thermocouple wires (gray and red) from terminals 10 and 8. Measure the continuity across the gray and red thermocouple leads. The measurement should read approximately 1-2 ohms. Larger values indicate the thermocouple is open.
3. If the thermocouple is open, replace the oxygen probe per Oxygen Probe Replacement in Section 6: Maintenance and Service.

Figure 5-6. Fault 2, Reversed Thermocouple



Fault 2, Reversed Thermocouple Active

The thermocouple connections are reversed. The fault displays as shown in Figure 5-6.

1. Allow adequate time for the oxygen probe to reach operating temperatures. Probe temperatures below approximately 500°C (932°F) may result in this fault.
2. Refer to Figure 5-4. Check the gray (to terminal 10) and red (to terminal 8) wires for the proper placement.
3. Using a multimeter, measure between terminals 8(-) and 10(+). If the reading is negative, the thermocouple wiring is reversed. Rewire as necessary.
4. If the wiring is correct and the probe is at operating temperature, then the transmitter electronics are bad. Replace the faulty analog or CPU board per Electronics Replacement in Section 6: Maintenance and Service.

Rosemount 5081FG

Figure 5-7. Fault 3, Shorted Thermocouple



39560058

Fault 3, Shorted Thermocouple

The thermocouple connections are shorted. The fault displays as shown in Figure 5-7.

1. Allow adequate time for the oxygen probe to reach operating temperatures. Probe temperatures below approximately 500°C (932°F) may result in this fault.
2. Refer to Figure 5-4. Using a multimeter, measure between terminals 8(-) and 10(+).
3. If the multimeter reading, in voltage mode, is between -0.5 and +0.5 mV, the thermocouple is shorted.
4. If the thermocouple is shorted, replace the oxygen probe per Oxygen Probe Replacement in Section 6: Maintenance and Service.
5. If the thermocouple is not shorted, then replace the faulty analog or CPU board per Electronics Replacement in Section 6: Maintenance and Service.

Figure 5-8. Fault 4, High Probe Temperature



39560058

Fault 4, High Probe Temperature

The probe's temperature has exceeded the maximum cell temperature setpoint. The fault displays as shown in Figure 5-8.

1. If the probe temperature exceeds the maximum cell temperature setpoint, the 4-20 mA signal output will become invalid and go to the default value.
2. Verify that the upper cell temperature setpoint is configured as desired under the PROGRAM MENU in Section 3: Startup and Operation.

Figure 5-9. Fault 5, O2 Cell Open



Fault 5, O2 Cell Open

The O₂ cell connection is open. The fault displays as shown in Figure 5-9.

1. Allow adequate time for the oxygen probe to reach operating temperatures. Probe temperatures below approximately 500°C (932°F) may result in this fault.
2. Refer to Figure 5-4 and check the O₂ cell wiring connections at terminals 7 and 8. Ensure the wires are properly connected.

NOTE

Check the cell output voltage at the probe terminals -- not at the electronics.

3. Apply low calibration check gas (0.4% O₂). Measure the cell output from the O₂ cell wires at the probe terminal block. The cell output should be 100 ±20 mV. If no voltage can be measured the cell is open.
4. If the O₂ cell is open, replace the oxygen probe per Oxygen Probe Replacement in Section 6: Maintenance and Service.

Figure 5-10. Fault 6, Cell Impedance Too High



Fault 6, Cell Impedance Too High

The O₂ cell impedance has exceeded 100 ohms. The fault displays as shown in Figure 5-10.

1. This fault is usually indicated in conjunction with Fault 5, Cell Open. Correcting Fault 5 should correct Fault 6.
2. Fault 6 appears independently, the cell has degraded beyond specification.
3. If the O₂ cell has become too old, replace the oxygen probe per Oxygen Probe Replacement in Section 6: Maintenance and Service.

Rosemount 5081FG

Figure 5-11. Fault 7, Reversed O₂ Cell



Fault 7, Reversed O₂ Cell

The O₂ cell connections are reversed. The fault displays as shown in Figure 5-11.

1. Refer to Figure 5-4. Check the black (to terminal 7) and white (to terminal 8) wires for the proper placement. Rewire if necessary.
2. Apply the low calibration check gas (0.4% O₂).
3. Using a multimeter measure between terminals 7(+) and 8(-). If the cell output reading is negative, the O₂ cell wiring is reversed.
4. If the wiring is correct, check if the multimeter reading is the same as the reading shown on the O₂ CELL mV diagnostics screen (Section 3: Startup and Operation).
5. If the reading is different the transmitter electronics are faulty. Replace the faulty analog or CPU board per Electronics Replacement in Section 6: Maintenance and Service.

CALIBRATION PASSES, BUT STILL READS INCORRECTLY

There are fault conditions where no alarm indication is present and the probe passes calibration, but the O₂ reading may still be incorrect:

Probe Passes Calibration, O₂ Still Reads High

External Reference Air Leak - There may be a leak that is permitting ambient air to mix with the process gases. Since many combustion processes are slightly negative in pressure, ambient air can be drawn into the cell area, biasing the O₂ reading upward.

1. Make sure that the calibration gas line is capped tightly between calibrations.

Bad Reference Side Cell Electrode - A bad reference side cell electrode can cause an elevated O₂ reading. This fault is usually indicated by a frequent "Calibration Recommended" alarm and increasing cell impedance readings. A high cell impedance can be calibrated out, but if the impedance continues to increase rapidly, the sensing cell must be replaced.

Section 6 Maintenance and Service

Overview	page 6-1
Electronics Replacement	page 6-1
Oxygen Probe Replacement	page 6-3

OVERVIEW

This section provides the procedures to maintain and service the Rosemount 5081FG Two-Wire In-Situ Oxygen Analyzer.

⚠ WARNING

Install all protective equipment covers and safety ground leads after equipment repair or service. Failure to install covers and ground leads could result in serious injury or death.

⚠ WARNING

Disconnect and lock out power before working on any electrical components.

ELECTRONICS REPLACEMENT

Before replacing any electronic components verify that the power to the Rosemount 5081 transmitter is removed. Refer to Section 7: Replacement Parts for replacement part numbers.

Display Board Replacement

Use the following procedure to replace the display board (12, Figure 6-1).

1. Loosen screw (15) until cover lock (16) disengages from the knurled surface of circuit end cap (14). Remove circuit end cap.
2. Remove three screws (13) retaining the electronics in place.
3. Lift display board (12) to disconnect from CPU board (11). The display board is plugged into the CPU board; use care when removing the display board.
4. Align and plug the replacement display board (12) in the desired orientation. Carefully plug the display board into the mating connector on CPU board (11). Ensure the display board is fully seated.
5. Install and tighten all three screws (13).
6. Install circuit end cap (14). Tighten cover lock screw (15) until cover lock (16) engages knurled surface of circuit end cap (14).

Figure 6-1. Two-Wire In-Situ Oxygen Analyzer - Exploded View

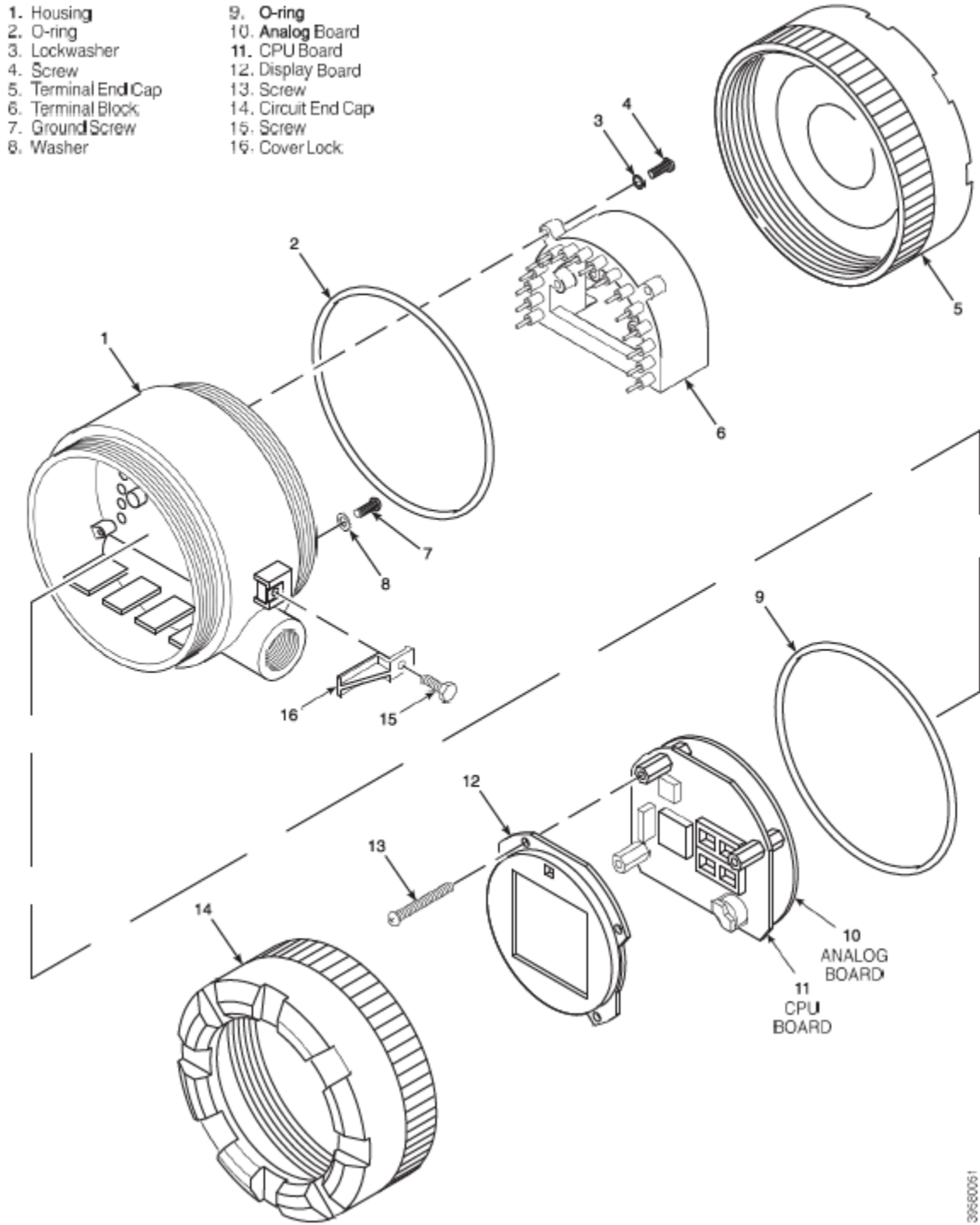

39560051

Spare Board Stack Replacement

The spare board stack is composed of the analog board (10, Figure 6-1) and the CPU board (11). Use the following procedure to replace either of these boards.

1. Loosen cover lock screw (15) until cover lock (16) disengages from the knurled surface of circuit end cap (14). Remove circuit end cap.
2. Remove three screws (13).
3. Lift display board (12) to disconnect from CPU board (11). The display board is plugged into the CPU board; use care when removing the display board.
4. Remove terminal end cap (5).
5. Remove two screws (4) and lockwashers (3). Lift terminal block (6) until the analog board (10) is unplugged from the terminal board.
6. Lift failed board stack from housing (1) by the standoffs. Reinstall terminal block (6), lockwashers (3), and screws (4).

NOTE

Rosemount 5081 analyzers shipped after August 2008 incorporate a new display board. If display board replacement is needed for an earlier analyzer unit, both the display and spare board stack must be replaced as matching parts. The earlier model analyzer uses a ribbon cable to connect the display board (12) to the CPU board (10).

7. Install new spare board stack into housing (1). Carefully seat the analog board onto housing pins. Press firmly on the CPU board standoffs to ensure good contact.
8. Align and plug the replacement display board (12) into the mating connector on the CPU board (11). Ensure the display board is fully seated.
9. Install and tighten all three screws.
10. Install terminal end cap (5) and circuit end cap (14). Tighten cover lock screw (15) until cover lock (16) engages knurled surface of circuit end cap (14).

OXYGEN PROBE REPLACEMENT

The oxygen probe is designed with ceramic materials to provide maximum life at elevated temperatures and is not rebuildable. The condition of the sensing cell can be determined periodically by two methods:

- Note the cell impedance at the electronics. When the impedance displays a warning indication (WARN), increase the frequency of impedance readings. A cell with a sustained high impedance indication (HI) indicates a probe that is beyond its useful life.
- Conduct a calibration check. Follow the prompts provided by the electronics through the process of flowing two calibration check gases of known values. Record the generated slope and constant values.

⚠ WARNING

Use heat resistant gloves and clothing when removing the probe. The probe can be as hot as 1600°C (2912°F). This can cause severe burns.

⚠ WARNING

Do not install or remove probes from a process where pressures are more than a few inches of H₂O positive pressure. Hot gases may escape from the stack and cause severe personal injury.

⚠ WARNING

Do not insert or withdraw a probe into or out of a hot process faster than 1 in. (25,4 mm) per minute or instrument damage from thermal shock may occur.

Also, ash, slag, or other materials can build up on the probe body in some applications. If this buildup is causing difficulty when withdrawing the probe, DO NOT FORCE. Rotate the probe back and forth to attempt to loosen the material on the probe body. Or, wait until the process cools down and access the buildup from inside the furnace.

Probe replacement may be conducted online as long as the process in which the probe is mounted is operating at a negative, or slightly positive, pressure. Refer to Section 5: Troubleshooting for more information.

Refer to Table 7-1 for replacement probe part numbers. Before replacing the probe, verify that the reference air and calibration check gas lines are turned off and disconnected from the probe.

1. Remove the end cap of the probe to expose the terminal block.
2. Refer to Figure 6-2. Disconnect the four wires (two oxygen signal wires and two thermocouple wires) from the terminal block.
3. Disconnect the reference air and the calibration check gas lines.
4. Unscrew the probe from the stack and remove.
5. Using a replacement probe, refer to Mechanical Installation in Section 2: Installation for mechanical installation instructions.
6. Refer to Electrical Installation in Section 2: Installation for electrical installation instructions.
7. Refer to Pneumatic Installation in Section 2: Installation for reference air and calibration check gas installation instructions.

Figure 6-2. Oxygen Probe
Terminal Block

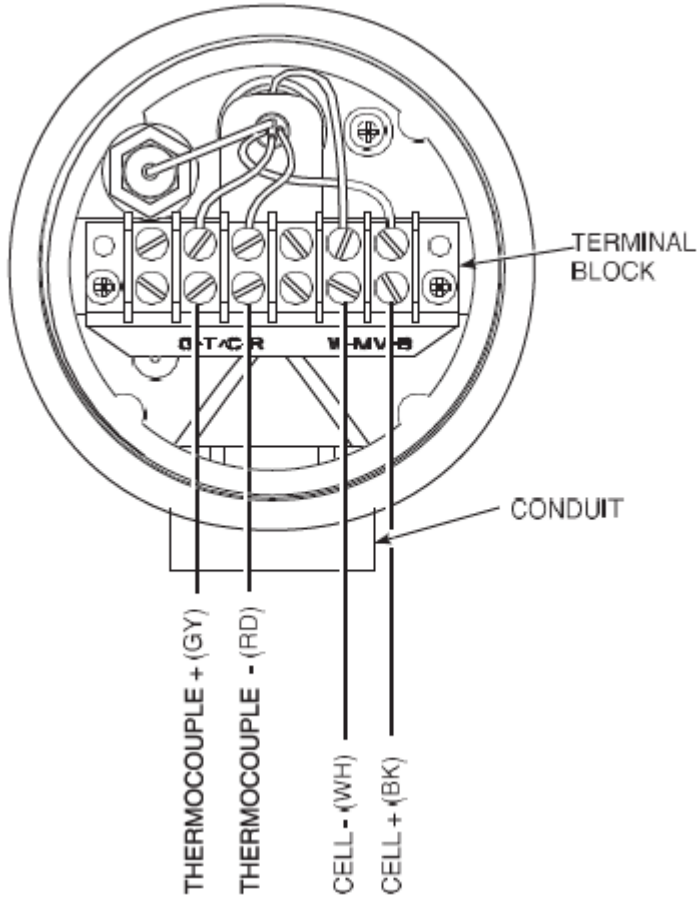

39580063

Section 7 Replacement Parts

Table 7-1. Replacement Parts List

Figure and Index Number	Part Number	Description
1-1, 2	6A00093G01	Rosemount 5081 Transmitter ATEX
1-1, 2	6A00093G02	Rosemount 5081 Transmitter CSA
1-1, 2	6A00093G03	Rosemount 5081 Transmitter FM
1-1, 3	5R10092G01	20" Replacement Oxygen Probe, with Alumina Outer Protection Tube
1-1, 3	5R10092G02	26" Replacement Oxygen Probe, with Alumina Outer Protection Tube
1-1, 3	5R10092G03	38" Replacement Oxygen Probe, with Alumina Outer Protection Tube
1-1, 3	5R10092G09	20" Replacement Oxygen Probe, with Inconel 600 Outer Protection Tube
1-1, 3	5R10092G10	26" Replacement Oxygen Probe, with Inconel 600 Outer Protection Tube
1-1, 3	5R10092G11	38" Replacement Oxygen Probe, with Inconel 600 Outer Protection Tube
6-1, 6	1A99777H04	Terminal Block
6-1, 10, 11, 12 and 13	1A99777H06	Spare Board Stack, HART Compatible, with Display Board Assembly
6-1, 12	1A99777H05	Display Board Assembly
6-1, 14	23593-01	Circuit End Cap (with Glass)
6-1, 5	1A99777H01	Terminal End Cap (without Glass)

NOTE

Rosemount 5081 analyzers shipped after August 2008 incorporate a new display board. If display board replacement is needed for an earlier analyzer unit, both the display and spare board stack must be replaced. The earlier model analyzer uses a ribbon cable to connect the display board (12) to the CPU board (11).

Rosemount 5081FG

Section 8 Rosemount 5081-G Product Certifications

European Directive information

A copy of the EC Declaration of Conformity can be found at the end of the Quick Start Guide. The most recent revision of the EC Declaration of Conformity can be found at Emerson.com/Rosemount.

Ordinary location certification

As standard, the transmitter has been examined and tested to determine that the design meets the basic electrical, mechanical, and fire protection requirements by a nationally recognized test laboratory (NRTL) as accredited by the Federal Occupational Safety and Health Administration (OSHA).

Installing equipment in North America

The US National Electrical Code (NEC) and the Canadian Electrical Code (CEC) permit the use of Division marked equipment in Zones and Zone marked equipment in Divisions. The markings must be suitable for the area classification, gas, and temperature class. This information is clearly defined in the respective codes.

USA

FM

Certificate: FM17US0021X
Standards: FM Class 3600:2011, FM Class 3610:2015, FM Class 3611:2016
FM Class 3615:2006, FM Class 3810:2005, ANSI/TYPE 250:1991

Markings:



Intrinsically Safe for use in Class I, II and III, Division 1, Groups A, B, C, D, E, F, and G; T4 Ta = -20 °C to 70 °C; Per Control Drawing Numbers 1400227; 1400228
Nonincendive for Class I, Division 2, Groups A, B, C, D; T4 Ta = -20 °C to 70 °C; Per Control Drawing Numbers 1400227; 1400228
Dust-Ignitionproof for use in Class II and Class III, Division 1, Groups E, F, G; T6 Ta = -20 °C to 70 °C; Per Control Drawing Number 1400678
Explosionproof for use in Class I, Div 1, Groups B, C, and D; T6 Ta = -20 °C to 70 °C; Per Control Drawing Number 1400678
Type 4X

Canada

CSA

Certificate: 1132747
Standards: C22.2 No. 0-M1987, C22.2 No. 25-1966, C22.2 No. 30-M1986
C22.2 No. 94-M91, C22.2 No 142-M1987, C22.2 No. 157-92,
C22.2 No. 213-M1987

Markings:



Intrinsically Safe for Class I Groups A, B, C, D; Class II Groups E, F, G; Class III; T4 Tamb = 70 °C, per Installation Drawing 1400229, 1400230
Non-Incendive for Class I, Div. 2 for Groups A, B, C, D; Class II, Div. 2, Groups F and G; Class III; T4 Tamb = 70 °C, per Installation Drawing 1400229, 1400230

Reference Manual

00809-0100-4882, Rev AB

May 2019

Rosemount 5081FG

Explosion-proof for Class I, Groups B, C, D; Class II, Groups E, F, G, Class III, T6 Tamb = 70 °C
Type 4X

Europe

ATEX

Certificate: Baseefa04ATEX0052X

Standards: EN 60079-0:2012+A11:2013

EN 60079-11:2012

Markings:  II 1 G

Ex ia IIC T4 Ga

(-20° ≤ Ta ≤ +65°C)

Special Conditions for Safe Use (X):

1. The equipment enclosure may contain light metals. The equipment must be installed in such a manner as to minimize the risk of impact or friction with other metal surfaces

International

IECEX

Certificate: IECEX BAS 09.0159X

Standards: IEC 60079-0:2011

IEC 60079-11:2011

Markings: Ex ia IIC T4 Ga

(-20° ≤ Ta ≤ +65°C)

Special Conditions for Safe Use (X):

1. The Model 5081 enclosure may be made of aluminum alloy and given a protective polyurethane paint finish; however, care should be taken to protect it from impact or abrasion if located in a zone 0 environment.

Appendix A Safety Data

Safety Instructions	page A-1
Safety Data Sheet for Ceramic Fiber Products	page A-2

SAFETY INSTRUCTIONS

IMPORTANT

**SAFETY INSTRUCTIONS FOR THE WIRING
AND INSTALLATION OF THIS APPARATUS**

The following safety instructions apply specifically to all EU member states. They should be strictly adhered to in order to assure compliance with the Low Voltage Directive. Non-EU states should also comply with the following unless superseded by local or National Standards.

1. Adequate earth connections should be made to all earthing points, internal and external, where provided.
2. After installation or troubleshooting, all safety covers and safety grounds must be replaced. The integrity of all earth terminals must be maintained at all times.
3. Mains supply cords should comply with the requirements of IEC227 or IEC245.
4. All wiring shall be suitable for use in an ambient temperature of greater than 75°C.
5. All cable glands used should be of such internal dimensions as to provide adequate cable anchorage.
6. To ensure safe operation of this equipment, connection to the mains supply should only be made through a circuit breaker which will disconnect all circuits carrying conductors during a fault situation. The circuit breaker may also include a mechanically operated isolating switch. If not, then another means of disconnecting the equipment from the supply must be provided and clearly marked as such. Circuit breakers or switches must comply with a recognized standard such as IEC947. All wiring must conform with any local standards.
7. Where equipment or covers are marked with the symbol to the right, hazardous voltages are likely to be present beneath. These covers should only be removed when power is removed from the equipment - and then only by trained service personnel.
8. Where equipment or covers are marked with the symbol to the right, there is a danger from hot surfaces beneath. These covers should only be removed by trained service personnel when power is removed from the equipment. Certain surfaces may remain hot to the touch.
9. Where equipment or covers are marked with the symbol to the right, refer to the Operator Manual for instructions.
10. All graphical symbols used in this product are from one or more of the following standards: EN61010-1, IEC417, and ISO3864.
11. Where equipment or labels are marked "Do Not Open While Energized" or similar, there is a danger of ignition in areas where an explosive atmosphere is present. This equipment should only be opened when power is removed and adequate time as specified on the label or in the instruction manual has been allowed for the equipment to cool down - and then only by trained service personnel.



SAFETY DATA SHEET FOR CERAMIC FIBER PRODUCTS

JULY 1, 1996

SECTION I. IDENTIFICATION

PRODUCT NAME

Ceramic Fiber Heaters, Molded Insulation Modules and Ceramic Fiber Radiant Heater Panels.

CHEMICAL FAMILY

Vitreous Aluminosilicate Fibers with Silicon Dioxide.

CHEMICAL NAME

N.A.

CHEMICAL FORMULA

N.A.

MANUFACTURER'S NAME AND ADDRESS

Watlow Columbia
2101 Pennsylvania Drive
Columbia, MO 65202
573-814-1300, ext. 5170
573-474-9402

HEALTH HAZARD SUMMARY WARNING

- Possible cancer hazard based on tests with laboratory animals.
- May be irritating to skin, eyes and respiratory tract.
- May be harmful if inhaled.
- Cristobalite (crystalline silica) formed at high temperatures (above 1800°F) can cause severe respiratory disease.

SECTION II. PHYSICAL DATA

APPEARANCE AND ODOR

Cream to white colored fiber shapes. With or without optional white to gray granular surface coating and/or optional black surface coating.

SPECIFIC WEIGHT: 12-25 LB./CUBIC FOOT

BOILING POINT: N.A.

VOLATILES (% BY WT.): N.A.

WATER SOLUBILITY: N.A.

SECTION III. HAZARDOUS INGREDIENTS

MATERIAL, QUANTITY, AND THRESHOLD/EXPOSURE LIMIT VALUES

Aluminosilicate (vitreous) 99+ % 1 fiber/cc TWA

CAS. No. 142844-00-0610 fibers/cc CL

Zirconium Silicate 0-10% 5 mg/cubic meter (TLV)

Black Surface Coating** 0 - 1% 5 mg/cubic meter (TLV)

Amorphous Silica/Silicon Dioxide 0-10% 20 mppcf (6 mg/cubic meter)

PEL (OSHA 1978) 3 gm cubic meter

(Respirable dust): 10 mg/cubic meter,

Intended TLV (ACGIH 1984-85)

**Composition is a trade secret.

SECTION IV. FIRE AND EXPLOSION DATA

FLASH POINT: None

FLAMMABILITY LIMITS: N.A.

EXTINGUISHING MEDIA

Use extinguishing agent suitable for type of surrounding fire.

UNUSUAL FIRE AND EXPLOSION HAZARDS / SPECIAL FIRE FIGHTING PROCEDURES

N.A.

SECTION V. HEALTH HAZARD DATA

THRESHOLD LIMIT VALUE

(See Section III)

EFFECTS OF OVER EXPOSURE

- EYE - Avoid contact with eyes. Slightly to moderately irritating. Abrasive action may cause damage to outer surface of eye.
- INHALATION - May cause respiratory tract irritation. Repeated or prolonged breathing of particles of respirable size may cause inflammation of the lung leading to chest pain, difficult breathing, coughing and possible fibrotic change in the lung (Pneumoconiosis). Pre-existing medical conditions may be aggravated by exposure: specifically, bronchial hyper-reactivity and chronic bronchial or lung disease.
- INGESTION - May cause gastrointestinal disturbances. Symptoms may include irritation and nausea, vomiting and diarrhea.
- SKIN - Slightly to moderate irritating. May cause irritation and inflammation due to mechanical reaction to sharp, broken ends of fibers.

EXPOSURE TO USED CERAMIC FIBER PRODUCT

Product which has been in service at elevated temperatures (greater than 1800°F/982°C) may undergo partial conversion to cristobalite, a form of crystalline silica which can cause severe respiratory disease (Pneumoconiosis). The amount of cristobalite present will depend on the temperature and length of time in service. (See Section IX for permissible exposure levels).

SPECIAL TOXIC EFFECTS

The existing toxicology and epidemiology data bases for RCF's are still preliminary. Information will be updated as studies are completed and reviewed. The following is a review of the results to date:

EPIDEMIOLOGY

At this time there are no known published reports demonstrating negative health outcomes of workers exposed to refractory ceramic fiber (RCF). Epidemiologic investigations of RCF production workers are ongoing.

1. There is no evidence of any fibrotic lung disease (interstitial fibrosis) whatsoever on x-ray.
2. There is no evidence of any lung disease among those employees exposed to RCF that had never smoked.
3. A statistical "trend" was observed in the exposed population between the duration of exposure to RCF and a decrease in some measures of pulmonary function. These observations are clinically insignificant. In other words, if these observations were made on an individual employee, the results would be interpreted as being within the normal range.
4. Pleural plaques (thickening along the chest wall) have been observed in a small number of employees who had a long duration of employment. There are several occupational and non-occupational causes for pleural plaque. It should be noted that plaques are not "pre-cancer" nor are they associated with any measurable effect on lung function.

TOXICOLOGY

A number of studies on the health effects of inhalation exposure of rats and hamsters are available. Rats were exposed to RCF in a series of life-time nose-only inhalation studies. The animals were exposed to 30, 16, 9, and 3 mg/m³, which corresponds with approximately 200, 150, 75, and 25 fibers/cc.

Animals exposed to 30 and 16 mg/m³ were observed to have developed a pleural and parenchymal fibroses; animals exposed to 9 mg/m³ had developed a mild parenchymal fibrosis; animals exposed to the lowest dose were found to have the response typically observed any time a material is inhaled into the deep lung. While a statistically significant increase in lung tumors was observed following exposure to the highest dose, there was no excess lung cancers at the other doses. Two rats exposed to 30 mg/m³ and one rat exposed to 9 mg/m³ developed mesotheliomas.

The International Agency for Research on Cancer (IARC) reviewed the carcinogenicity data on man-made vitreous fibers (including ceramic fiber, glasswool, rockwool, and slagwool) in 1987. IARC classified ceramic fiber, fibrous glasswool and mineral wool (rockwool and slagwool) as possible human carcinogens (Group 2B).

EMERGENCY FIRST AID PROCEDURES

- **EYE CONTACT** - Flush eyes immediately with large amounts of water for approximately 15 minutes. Eye lids should be held away from the eyeball to insure thorough rinsing. Do not rub eyes. Get medical attention if irritation persists.
- **INHALATION** - Remove person from source of exposure and move to fresh air. Some people may be sensitive to fiber induced irritation of the respiratory tract. If symptoms such as shortness of breath, coughing, wheezing or chest pain develop, seek medical attention. If person experiences continued breathing difficulties, administer oxygen until medical assistance can be rendered.
- **INGESTION** - Do not induce vomiting. Get medical attention if irritation persists.
- **SKIN CONTACT** - Do not rub or scratch exposed skin. Wash area of contact thoroughly with soap and water. Using a skin cream or lotion after washing may be helpful. Get medical attention if irritation persists.

SECTION VI. REACTIVITY DATA

STABILITY/CONDITIONS TO AVOID

Stable under normal conditions of use.

HAZARDOUS POLYMERIZATION/CONDITIONS TO AVOID

N.A.

INCOMPATIBILITY/MATERIALS TO AVOID

Incompatible with hydrofluoric acid and concentrated alkali.

HAZARDOUS DECOMPOSITION PRODUCTS

N.A.

SECTION VII. SPILL OR LEAK PROCEDURES

STEPS TO BE TAKEN IF MATERIAL IS RELEASED OR SPILLED

Where possible, use vacuum suction with HEPA filters to clean up spilled material. Use dust suppressant where sweeping if necessary. Avoid clean up procedure which may result in water pollution. (Observe Special Protection Information Section VIII.)

WASTE DISPOSAL METHODS

The transportation, treatment, and disposal of this waste material must be conducted in compliance with all applicable Federal, State, and Local regulations.

SECTION VIII. SPECIAL PROTECTION INFORMATION**RESPIRATORY PROTECTION**

Use NIOSH or MSHA approved equipment when airborne exposure limits may be exceeded. NIOSH/MSHA approved breathing equipment may be required for non-routine and emergency use. (See Section IX for suitable equipment).

Pending the results of long term health effects studies, engineering control of airborne fibers to the lowest levels attainable is advised.

VENTILATION

Ventilation should be used whenever possible to control or reduce airborne concentrations of fiber and dust. Carbon monoxide, carbon dioxide, oxides of nitrogen, reactive hydrocarbons and a small amount of formaldehyde may accompany binder burn off during first heat. Use adequate ventilation or other precautions to eliminate vapors resulting from binder burn off. Exposure to burn off fumes may cause respiratory tract irritation, bronchial hyper-reactivity and asthmatic response.

SKIN PROTECTION

Wear gloves, hats and full body clothing to prevent skin contact. Use separate lockers for work clothes to prevent fiber transfer to street clothes. Wash work clothes separately from other clothing and rinse washing machine thoroughly after use.

EYE PROTECTION

Wear safety glasses or chemical worker's goggles to prevent eye contact. Do not wear contact lenses when working with this substance. Have eye baths readily available where eye contact can occur.

SECTION IX. SPECIAL PRECAUTIONS**PRECAUTIONS TO BE TAKEN IN HANDLING AND STORING**

General cleanliness should be followed.

The Toxicology data indicate that ceramic fiber should be handled with caution. The handling practices described in this MSDS must be strictly followed. In particular, when handling refractory ceramic fiber in any application, special caution should be taken to avoid unnecessary cutting and tearing of the material to minimize generation of airborne dust.

It is recommended that full body clothing be worn to reduce the potential for skin irritation. Washable or disposable clothing may be used. Do not take unwashed work clothing home. Work clothes should be washed separately from other clothing. Rinse washing machine thoroughly after use. If clothing is to be laundered by someone else, inform launderer of proper procedure. Work clothes and street clothes should be kept separate to prevent contamination.

Product which has been in service at elevated temperatures (greater than 1800°F/982°C) may undergo partial conversion to cristobalite, a form of crystalline silica. This reaction occurs at the furnace lining hot face. As a consequence, this material becomes more friable; special caution must be taken to minimize generation of air-borne dust. The amount of cristobalite present will depend on the temperature and length in service.

IARC has recently reviewed the animal, human, and other relevant experimental data on silica in order to critically evaluate and classify the cancer causing potential. Based on its review, IARC classified crystalline silica as a group 2A carcinogen (probable human carcinogen).

The OSHA permissible exposure limit (PEL for cristobalite is 0.05 mg/m³ (respirable dust). The ACGIH threshold limit value (TLV) for cristobalite is 0.05 mg/m³ (respirable dust) (ACGIH 1991-92). Use NIOSH or MSHA approved equipment when airborne exposure limits may be exceeded. The minimum respiratory protection recommended for given airborne fiber or cristobalite concentrations are:

CONCENTRATION

Concentration	Personal Protective Equipment
0-1 fiber/cc or 0-0.05 mg/m ³ cristobalite (the OSHA PEL)	Optional disposable dust respirator (e.g. 3M 9970 or equivalent).
Up to 5 fibers/cc or up to 10 times the OSHA PEL for cristobalite	Half face, air purifying respirator equipped with high efficiency particulate air (HEPA) filter cartridges (e.g. 3M 6000 series with 2040 filter or equivalent).
Up to 25 fibers/cc or 50 times the OSHA PEL for cristobalite (2.5 mg/m ³)	Full face, air purifying respirator with high efficiency particulate air (HEPA) filter cartridges (e.g. 3M 7800S with 7255 filters or equivalent) or powered air purifying respirator (PARR) equipped with HEPA filter cartridges (e.g. 3M W3265S with W3267 filters or equivalent).
Greater than 25 fibers/cc or 50 times the OSHA PEL for cristobalite (2.5 mg/m ³)	Full face, positive pressure supplied air respirator (e.g. 3M 7800S with W9435 hose & W3196 low pressure regulator kit connected to clean air supply or equivalent).

If airborne fiber or cristobalite concentrations are not known, as minimum protection, use NIOSH/MSHA approved half face, air purifying respirator with HEPA filter cartridges.

Insulation surface should be lightly sprayed with water before removal to suppress airborne dust. As water evaporates during removal, additional water should be sprayed on surfaces as needed. Only enough water should be sprayed to suppress dust so that water does not run onto the floor of the work area. To aid the wetting process, a surfactant can be used.

After RCF removal is completed, dust suppressing cleaning methods, such as wet sweeping or vacuuming, should be used to clean the work area. If dry vacuuming is used, the vacuum must be equipped with HEPA filter. Air blowing or dry sweeping should not be used. Dust suppressing components can be used to clean up light dust.

Product packaging may contain product residue. Do not reuse except to reship or return Ceramic Fiber products to the factory.

Appendix B Return of Material

RETURNING MATERIAL

SERVICE SUPPORT - To expedite the return process outside of the United States, contact the nearest Emerson representative. Within the United States, call the Emerson Instrument and Valves Response Center using the 1-800-654-RSMT (7768) toll-free number. This center, available 24 hours a day, will assist you with any needed information or materials. The center will ask for product model and serial numbers, and will provide a Return Material Authorization (RMA) number. The center will also ask for the process material to which the product was last exposed. Emerson Instrument and Valves Response Center representatives will explain the additional information and procedures necessary to return goods exposed to hazardous substances.

Rosemount 5081FG

Reference Manual
00809-0100-4882, Rev AB
June 2019

EC Declaration of Conformity



EU Declaration of Conformity

No: RAD 1124 Rev. B

5081-G

We,

Rosemount Inc.
8200 Market Boulevard
Chanhassen, MN 55317-9685
USA

declare under our sole responsibility that the product,

Rosemount™ Oxygen Gas Transmitter model 5081-AA-BB-CC

manufactured by,

Rosemount Inc.
8200 Market Boulevard
Chanhassen, MN 55317-9685
USA

to which this declaration relates, is in conformity with the provisions of the European Union Directives, including the latest amendments, as shown in the attached schedule.

Assumption of conformity is based on the application of the harmonized standards and, when applicable or required, a European Union notified body certification, as shown in the attached schedule.

(signature)

Chris LaPoint

(name)

Vice President of Global Quality

(function)

1-Feb-19, Shakopee, MN USA

(date of issue & place)



EU Declaration of Conformity

No: RAD 1124 Rev. B

Rosemount™ Oxygen Gas Transmitter model 5081-AA-BB-CC

Where			
AA is:		CC is:	
G	Oxygen Gas measurement	60	CSA, Intrinsically Safe, NonIncendive
		67	FM, Intrinsically Safe, NonIncendive
BB is:		69	CSA, Intrinsically Safe, NonIncendive
HT	Analog/HART communications	73	ATEX / IECEx, Intrinsically Safe
FF	Fieldbus communications		

to which this declaration relates, is in conformity with relevant Union harmonization legislation:

EMC Directive (2014/30/EU)

Harmonized Standards:
EN 61326-1:2013

ATEX Directive (2014/34/EU) (The ATEX Directive is only valid if option 73 is selected)

Baseefa04ATEX0052X – Intrinsically Safe

Equipment Group II, Category 1 G Ex ia IIC T4 Ga (-20°C ≤ Ta ≤ +65°C)

Special Condition for use:

The equipment enclosure may contain light metals. The apparatus must be installed in such a manner as to minimize the risk of impact or friction with other metal surfaces.

Harmonized Standards:
EN 60079-0:2012+A11:2013
EN 60079-11:2012

ATEX Notified Body for EC Type Examination Certificate & Quality Assurance

SGS FIMKO OY [Notified Body Number: 0598]

P.O. Box 30 (Särkiniementie 3)

00211 HELSINKI

Finland

表格 1: 含有China RoHS管控物质超过最大浓度限值的部件型号列
Table 1: List of Model Parts with China RoHS Concentration above MCVs

部件名称 Part Name	有害物质 / Hazardous Substances					
	铅 Lead (Pb)	汞 Mercury (Hg)	镉 Cadmium (Cd)	六价铬 Hexavalent Chromium (Cr +6)	多溴联苯 Polybrominated biphenyls (PBB)	多溴联苯醚 Polybrominated diphenyl ethers (PBDE)
电子组件 Electronics Assembly	X	O	O	O	O	O
壳体组件 Housing Assembly	X	O	O	X	O	O

本表格系依据 SJ/T11364 的规定而制作。

This table is proposed in accordance with the provision of SJ/T11364

O: 意为该部件的所有均质材料中该有害物质的含量均低于 GB/T 26572 所规定的限量要求。

O: Indicate that said hazardous substance in all of the homogeneous materials for this part is below the limit requirement of GB/T 26572.

X: 意为在该部件所使用的所有均质材料里，至少有一类均质材料中该有害物质的含量高于 GB/T 26572 所规定的限量要求。

X: Indicate that said hazardous substance contained in at least one of the homogeneous materials used for this part is above the limit requirement of GB/T 26572.

Index

A

Adapter Plate	2-5
Adjustable Parameters	
Cell T Hi	3-10
Display Code	3-9
Fault Val	3-9
Reset Max Cell T	3-11
Adjustable Paramters	
Code	3-8
Set Code	3-15
Set Hi Bottle O2	3-14
Set Lo Bottle O2	3-14
Set O2 Filter Time	3-11
Set O2 Tracking	3-15
Upper Range Val	3-10
Adjusting Probe	
Insertion Depth	2-7

C

Cal Check Menu	3-21
Accept High O2	3-22
Accept Low O2	3-22
Constant	3-23
In Manual?	3-21
Slope	3-23
Calibration Gas	2-15
Calibration Passes, but Still	
Reads Incorrectly	5-8
Component Checklist	1-1

D

Definitions	iv
Diagnostics	
Cell Impedance	3-18
Current Constant	3-19
Current Slope	3-18
Max Cell T	3-20
O2 Cell mV	3-17
Previous Constant	3-20
Previous Slope	3-19
Show Fault	3-16
SW Build Date	3-21
SW Build Number	3-21
SW Ver	3-21
T/C mV	3-17
Unit Ser #	3-21

Diagnostics Menu	3-16
Display Board Replacement . .	6-1
Display Positioning	2-10
Display, Startup	3-1

E

Electronics Replacement	6-1
Essential Instructions	i
Establish Proper Cal	
Gas Flow Rate	3-3
Exploded View	6-2

F

Fault 1, Open Thermocouple .	5-5
Fault 2, Reversed	
Thermocouple Active	5-5
Fault 3, Shorted	
Thermocouple	5-6
Fault 4, High Probe	
Temperature	5-6
Fault 5, O2 Cell Open	5-7
Fault 6, Cell Impedance	
Too High	5-7
Fault 7, Reversed O2 Cell . . .	5-8
Fault Indications	5-3
Faulted Operation Display . . .	5-3
Field Communicator	
PC Connections	4-4

H

Handling the Analyzer	1-6
HART/AMS Menu Tree	4-4
Horizontal Probe Installation . .	2-6

I

Identifying And Correcting Fault	
Indications	5-4
Infrared Remote Control (IRC)	3-6
Installation	
Electrical	2-11
Mechanical	2-2
Pneumatic	2-14
Instrument Air	2-14

L

Locating Oxygen Probe	2-2
-----------------------------	-----

M

Maintenance	6-1
Material Safety Data Sheet . .	A-24
Menu Tree	3-4
HART	4-5
Rosemount 5081 Transmitter	
Installing	2-8
Locating	2-7

O

Off-Line and On-Line	
Operations	4-4
Operating Display	3-2
Operation	3-4
Operator Adjustable	
Parameters	3-7
Oxygen Probe	
Installing	2-4
Oxygen Probe Replacement . .	6-3
Oxygen Probe Signal	
Connections	2-12
Oxygen Probe Terminal Block .	6-5

P

Parameters	
Trim 20mA?	3-13
Trim 4mA?	3-12
Parts, Replacement	7-1
Power Supply and Load	
Requirements	1-8
Power Up	3-1
Preface	iv
Pre-Installation	2-2
Probe Installation Details	2-3
Probe Life	5-1
Probe Mounting Flange	2-5
Prod.125	
.....	1-9
Program Men	3-7

R

Reference Air Package.....	2-14
Replacement Parts	7-1
Replacement Parts List	7-1
Returning Material	B-1

S

Service	6-1
Signal Line Connections	4-2
Software Navigation	3-6
Spare Board Stack	
Replacement	6-3
Specifications	1-7
Start Cal Check Method	
HART	4-8
Symbols	iv
System Configuration	1-4
System Considerations	1-6
System Description	1-3
System Features	1-4
System Overview.....	1-3

T

Technical Support Hotline.....	iv
Transmitter 4-20 mA and Signal	
Connections	2-13
Transmitter Mounting Dimensions	
Flat Surface	2-8
Pipe	2-9
Transmitter Terminal Block . . .	5-4
Troubleshooting	5-1
Typical System Installation . . .	1-6
Typical System Package	1-2

WARRANTY

Rosemount warrants that the equipment manufactured and sold by it will, upon shipment, be free of defects in workmanship or material. Should any failure to conform to this warranty become apparent during a period of one year after the date of shipment, Rosemount shall, upon prompt written notice from the purchaser, correct such nonconformity by repair or replacement, F.O.B. factory of the defective part or parts. Correction in the manner provided above shall constitute a fulfillment of all liabilities of Rosemount with respect to the quality of the equipment.

THE FOREGOING WARRANTY IS EXCLUSIVE AND IN LIEU OF ALL OTHER WARRANTIES OF QUALITY WHETHER WRITTEN, ORAL, OR IMPLIED (INCLUDING ANY WARRANTY OF MERCHANTABILITY OF FITNESS FOR PURPOSE).

The remedy(ies) provided above shall be purchaser's sole remedy(ies) for any failure of Rosemount to comply with the warranty provisions, whether claims by the purchaser are based in contract or in tort (including negligence).

Rosemount does not warrant equipment against normal deterioration due to environment. Factors such as corrosive gases and solid particulates can be detrimental and can create the need for repair or replacement as part of normal wear and tear during the warranty period.

Equipment supplied by Rosemount but not manufactured by it will be subject to the same warranty as is extended to Rosemount by the original manufacturer.

At the time of installation it is important that the required services are supplied to the system and that the electronic controller is set up at least to the point where it is controlling the sensor heater. This will ensure, that should there be a delay between installation and full commissioning that the sensor being supplied with ac power and reference air will not be subjected to component deterioration.

CAUTION

The oxygen probe is designed for industrial applications. Treat with care to avoid physical damage. The probe contains components made from ceramic, which are susceptible to shock when mishandled. THE WARRANTY DOES NOT COVER DAMAGE FROM MISHANDLING. WARRANTY IS VOID IF OUTER PROTECTION TUBE IS BROKEN.

Global Headquarters

Emerson Automation

Solutions 6021 Innovation Blvd.
Shakopee, MN 55379, USA
+1 800 999 9307 or +1 952 906 8888
+1 952 949 7001
Gas.CSC@Emerson.com

North America

Emerson Automation Solutions

8200 Market Blvd.
Chanhassen, MN 55317, USA
+1 800 999 9307 or +1 952 906 8888
+1 952 949 7001
Gas.CSC@Emerson.com

Latin America

Emerson Automation Solutions

1300 Concord Terrace, Suite 400
Sunrise, FL 33323, USA
+1 954 846 5030
+1 952846 5121
Gas.CSC@Emerson.com

Europe

Emerson Automation Solutions Europe GmbH

Neuhofstrasse 19a P.O. Box 1046
CH 6340 Baar
Switzerland
+1 954 846 5030
+1 952846 5121
Gas.CSC@Emerson.com

Asia Pacific

Emerson Automation Solutions Asia Pacific Pte LTD

1 Pandan Crescent
Singapore 128461
+65 6777 8211
+65 6777 0947
Gas.CSC@Emerson.com

Middle East

Emerson Automation

Solutions Emerson FZE P.O. Box
17033 Jebel Ali Free Zone - South
2
+971 4 8118100
+971 4 88665465
Gas.CSC@Emerson.com



[Linkedin.com/company/Emerson-Automation-Solutions](https://www.linkedin.com/company/Emerson-Automation-Solutions)



[Twitter.com/Rosemount_News](https://twitter.com/Rosemount_News)



[Facebook.com/Rosemount](https://www.facebook.com/Rosemount)



[Youtube.com/user/RosemountMeasurement](https://www.youtube.com/user/RosemountMeasurement)

© 2019 Emerson. All rights reserved.

The Emerson logo is a trademark and service mark of Emerson Electric Co. Rosemount and Rosemount logotype are trademarks of Emerson. All other marks are the property of their respective owners.