

Rosemount™ FCL

Free Chlorine System with Rosemount 1056 Transmitter



Essential instructions

Read this page before proceeding!

Emerson designs, manufactures, and tests its products to meet many national and international standards. Because these instruments are sophisticated technical products, you must properly install, use, and maintain them to ensure they continue to operate within their normal specifications. You must adhere to the following instructions and integrate them into your safety program when installing, using, and maintaining Emerson's Rosemount products. Failure to follow the proper instructions may cause any one of the following situations to occur: loss of life, personal injury, property damage, damage to this instrument, and warranty invalidation.

- Read all instructions prior to installing, operating, and servicing the product.
- If this reference manual is not the correct one, call 1-800-854-8257 or 949-757-8500 to request the correct reference manual. Save this reference manual for future reference.
- If you do not understand any of the instructions, contact your Emerson representative for clarification.
- Follow all warnings, cautions, and instructions marked on and supplied with the product.
- Inform and educate your personnel in the proper installation, operation, and maintenance of the product.
- Install equipment as specified in the installation instructions of the appropriate Quick Start Guide and per applicable local and national codes. Connect all products to the proper electrical and pressure sources.
- To ensure proper performance, use qualified personnel to install, operate, update, program, and maintain the product.
- When replacement parts are required, ensure that qualified people use replacement parts specified by Emerson. Unauthorized parts and procedures can affect the product's performance, place the safe operation of your process at risk, and may result in fire, electrical hazards, or improper operation.
- Ensure that all equipment doors are closed and protective covers are in place, except when maintenance is being performed by qualified people, to prevent electrical shock and personal injury.

⚠ WARNING

Hazardous area installation

Qualified on-site safety personnel must carefully evaluate installations near flammable liquids or in hazardous areas. This device is not Intrinsically Safe or Explosion Proof.

To secure and maintain intrinsically safe installation, use an appropriate transmitter/safety barrier/sensor combination. The installation system must be in accordance with the governing approval agency (FM, CSA, or BASEEFA/CENELEC) hazardous area classification requirements. Consult your transmitter Reference Manual for details.

Proper installation, operation, and servicing of this sensor in a hazardous area installation are entirely the operator's responsibility.

⚠ WARNING

Electrical shock

Making cable connections to and servicing this instrument require access to shock hazard level voltages, which can cause death or serious injury.

Equipment protected throughout by double insulation.

Be sure to disconnect all hazardous voltages before opening the enclosure.

Disconnect relay contacts made to separate power sources before servicing.

Electrical installation must be in accordance with the National Electrical Code (ANSI/NFPA-70) and/or any other national or local codes.

Unused cable conduit entries must be securely sealed by non-flammable closures to provide exposure integrity in compliance with personal safety and environmental protection requirements. Unused conduit openings must be sealed with NEMA 4X or IP65 conduit plugs to maintain the ingress protection rating (IP65).

Safety and performance require that this instrument be connected and properly grounded through a three-wire power source.

Proper use and configuration is the operator's responsibility.

No external power to the instrument of more than 69 Vdc or 43 V peak is allowed, with the exception of power and relay terminals. Any violation will impair the safety protection provided.

Do not operate this instrument without the front cover secured. Refer installation, operation, and servicing to qualified personnel.

⚠ WARNING

This product is not intended for use in the light industrial, residential, or commercial environments per the instrument's certification to EN50081-2.

⚠ CAUTION

Sensor/process application compatibility

The wetted sensor materials may not be compatible with process composition and operating conditions.

Application compatibility is entirely the operator's responsibility.

⚠ WARNING

Physical access

Unauthorized personnel may potentially cause significant damage to and/or misconfiguration of end users' equipment. This could be intentional or unintentional and needs to be protected against.

Physical security is an important part of any security program and fundamental in protecting your system. Restrict physical access by unauthorized personnel to protect end users' assets. This is true for all systems used within the facility.

Contents

Chapter 1	Installation.....	7
	1.1 Unpacking and inspection.....	7
	1.2 General installation information.....	7
	1.3 Sample requirements.....	8
	1.4 Mounting, inlet, and drain connections.....	8
	1.5 Install the sensor(s).....	11
Chapter 2	Wiring.....	13
	2.1 Wire power.....	13
	2.2 Analog output wiring.....	13
	2.3 Alarm wiring.....	14
	2.4 Wire sensor.....	15
	2.5 Use Quick Start.....	17
Chapter 3	Display and operation.....	23
	3.1 Display.....	23
	3.2 Keypad.....	24
	3.3 Program the transmitter.....	25
	3.4 Security.....	27
	3.5 Using hold.....	28
	3.6 Configure the main display.....	29
Chapter 4	Programming the transmitter.....	33
	4.1 Programming overview.....	33
	4.2 Default settings.....	33
	4.3 Configuring, ranging, and simulating outputs.....	36
	4.4 Configuring alarms and assigning setpoints.....	41
	4.5 Configuring measurement.....	47
	4.6 Configuring temperature related settings.....	50
	4.7 Configuring security settings.....	51
	4.8 Setting up diagnostics.....	53
	4.9 Resetting the transmitter.....	54
Chapter 5	Calibration.....	57
	5.1 Calibrate menu.....	57
	5.2 Calibrate temperature.....	57
	5.3 Free chlorine calibration.....	58
	5.4 pH calibration.....	64
	5.5 Calibrating analog outputs.....	69
Chapter 6	Digital communications.....	71
Chapter 7	Maintenance.....	73
	7.1 Replace sensor circuit board.....	73
	7.2 Chlorine sensor.....	73
	7.3 pH sensor.....	76

	7.4 Constant head flow controller.....	77
Chapter 8	Troubleshooting.....	81
	8.1 Overview of troubleshooting.....	81
	8.2 Use the diagnostic feature.....	81
	8.3 Troubleshooting when a Fault message is showing.....	82
	8.4 Troubleshooting when a Warning message is showing.....	86
	8.5 Troubleshooting when no error message is showing - chlorine.....	88
	8.6 Troubleshooting when no error message is showing - pH.....	92
	8.7 Troubleshooting when no error message is showing - general.....	96
	8.8 Simulate chlorine inputs.....	97
	8.9 Simulate pH input.....	98
	8.10 Simulating temperature.....	99

1 Installation

1.1 Unpacking and inspection

Procedure

1. Inspect the shipping container(s). If there is damage, then contact the shipper immediately for instructions.
2. If there is no apparent damage, then unpack the container(s).
3. Ensure that all items shown on the packing list are present.
If items are missing, then notify Emerson immediately.

1.1.1 Rosemount FCL-01 (free chlorine without continuous pH correction)

The FCL-01 consists of the following items mounted on a back plate.

1. 1056-03-24-38-AN Transmitter with sensor cable attached.
2. Constant head overflow sampler with flow cell for chlorine sensor.

The free chlorine sensor (499ACL-01-54-VP), three membrane assemblies, and a bottle of electrolyte solution are in a separate package.

1.1.2 Rosemount FCL-02 (free chlorine with continuous pH correction)

The FCL-02 consists of the following items mounted on a back plate:

1. 1056-03-24-32-AN Transmitter with sensor cables attached.
2. Constant head overflow sampler with flow cells for pH and chlorine sensors.
3. Stand to hold pH buffer solution during calibration.

The free chlorine sensor (499ACL-01-54-VP), shipped with three membrane assemblies and a bottle of electrolyte solution, and the 3900VP-02-10 pH Sensor are in separate packages.

1.2 General installation information

1. Although the system is suitable for outdoor use, do not install it in direct sunlight or in areas of extreme temperature.

▲ WARNING

Hazardous areas

The system is not suitable for use in hazardous areas.

2. To keep the transmitter enclosure watertight, install plugs (provided) in the unused conduit openings.
3. Install the system in an area where vibrations and electromagnetic and radio frequency interference are minimized or absent.

4. Be sure there is easy access to the transmitter and sensor(s).

1.3 Sample requirements

Be sure the sample meets the following requirements:

1. Temperature: +32 to +122 °F (0 to +50 °C)
2. Pressure: 3 to 65 psig (0.2 to 4.5 barg)
3. Minimum flow: 3 gal/hr (11 L/hr)

1.4 Mounting, inlet, and drain connections

The Rosemount FCL is intended for wall mounting only.

Refer to [Figure 1-1](#) or [Figure 1-2](#) for details. The sensor(s) screw into the flow cell adapters as shown in the figures. For FCL-02 (free chlorine with continuous pH adjustment), you must also install the pH sensor.

Figure 1-1: FCL-01

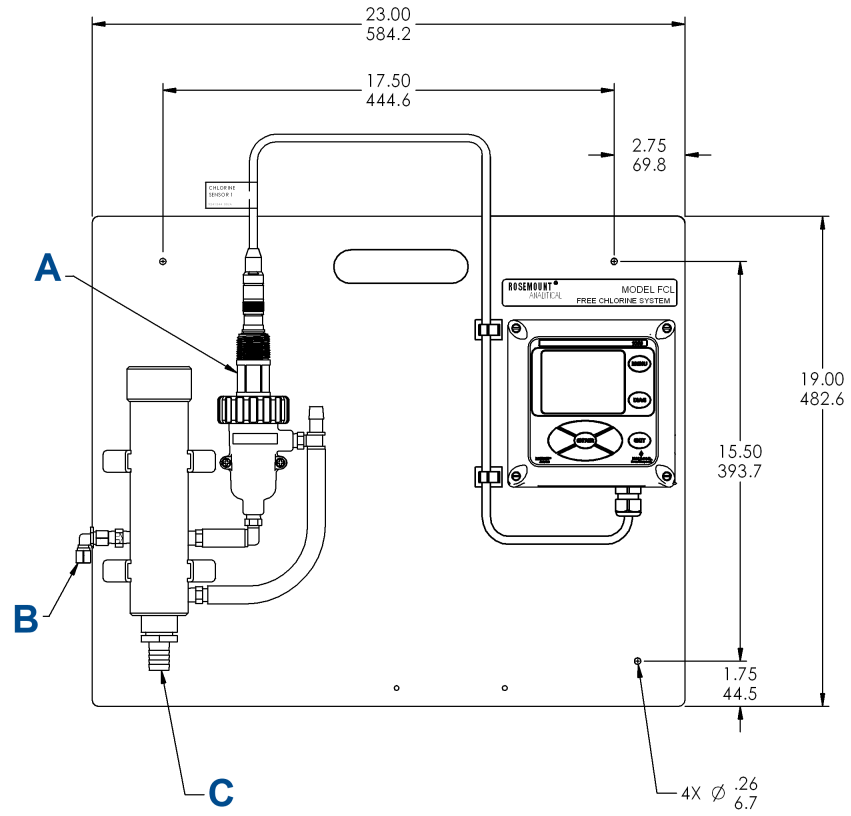

Dimensions are shown with inches above and millimeters below.

- A. Chlorine sensor
- B. Inlet
- C. Drain

Figure 1-2: FCL-02

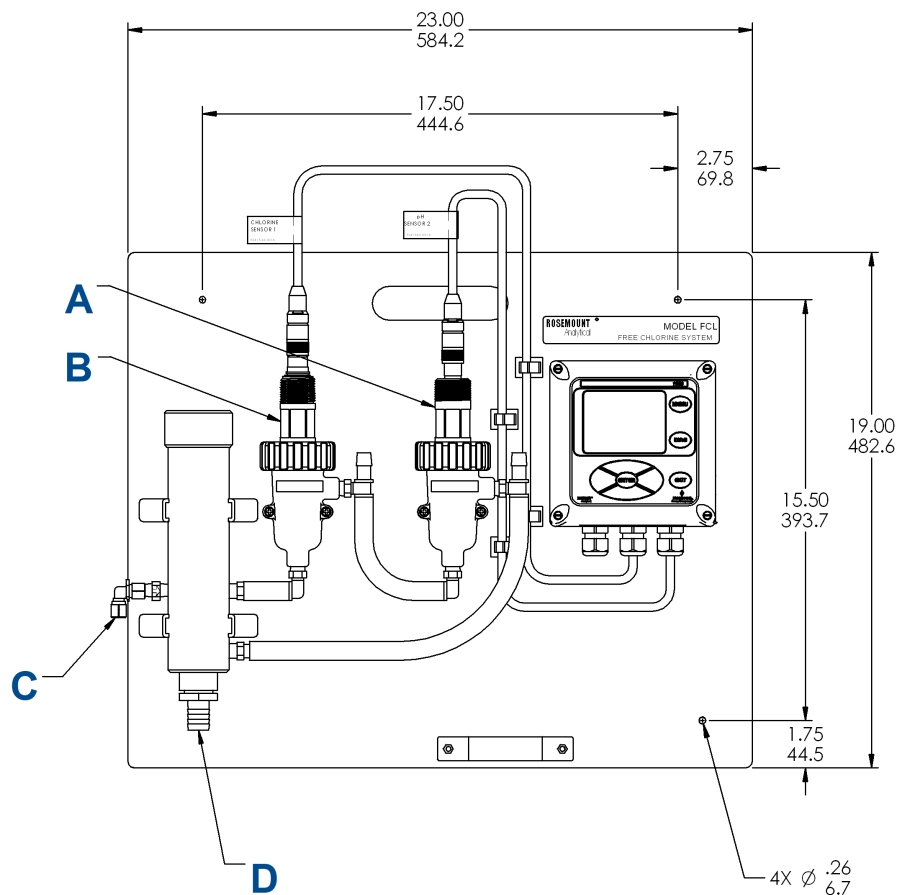

Dimensions are shown with inches above and millimeters below.

- A. pH sensor
- B. Chlorine sensor
- C. Inlet
- D. Drain

A ¼-in. outer dimension (OD) tubing compression fitting is provided for the sample inlet. If desired, you can remove the compression fitting and replace it with a barbed fitting. The fitting screws into a ¼-in. female NPT (FNPT) check valve. The check valve prevents the sensor flow cell from going dry if sample flow is lost.

The sample drains through a ¾-in. barbed fitting.

1. Attach a piece of soft tubing to the fitting and allow the waste to drain to open atmosphere.

NOTICE

Do not restrict the drain line.

2. Adjust the sample flow until the water level is even with the central overflow tube and excess water is flowing down the tube.
3. Confirm that sample is flowing through the flow cells.

1.5 Install the sensor(s)

Emerson provides the Rosemount FCL with the sensor cable pre-wired to the transmitter.

Procedure

1. Connect the chlorine sensor (499ACL-01-54-VP) to the cable labeled **CL**.
2. Connect the pH sensor (3900-VP-02-10) to the cable labeled **pH**.
The terminal end of the sensor is keyed to ensure proper mating with the cable receptacle.
3. Once the key has slid into the mating slot, tighten the connection by turning the knurled ring clockwise.
4. Screw the sensor(s) into the plastic fitting(s), which are held in the flow cell(s) by the union nut.
Do not remove the protective cap on the sensor(s) until ready to put the sensor(s) in service.

2 Wiring

2.1 Wire power

Wire AC mains power supply to the power supply board, which is mounted vertically on the left hand side of the transmitter enclosure.

⚠ WARNING

Electrical shock

Electrical installation must be in accordance with the National Electrical Code (American National Standards Institute [ANSI]/National Fire Protection Association [NFPA]-70) and/or any other applicable national or local codes.

The power connector is at the top of the board.

Procedure

1. Unplug the connector from the board and wire the power cable to it.
Lead connections are marked on the connector. (**L** is live or hot; **N** is neutral; the ground connection has the standard symbol.)
2. Run the power wiring through the conduit opening nearest the power terminal.
AC power wiring should be 14 gauge or greater.
3. Provide a switch or breaker to disconnect the transmitter from the main power supply.
4. Install the switch or breaker near the transmitter and label it as the disconnecting device for the transmitter.

2.2 Analog output wiring

Two analog output currents are located on the main circuit board, which is attached to the inside of the enclosure door.

Figure 2-1 shows the locations of the terminals. The connectors can be detached for wiring. **TB-1** is output 1. **TB-2** is output 2. Polarity is marked on the circuit board.

Figure 2-1: Analog output connections

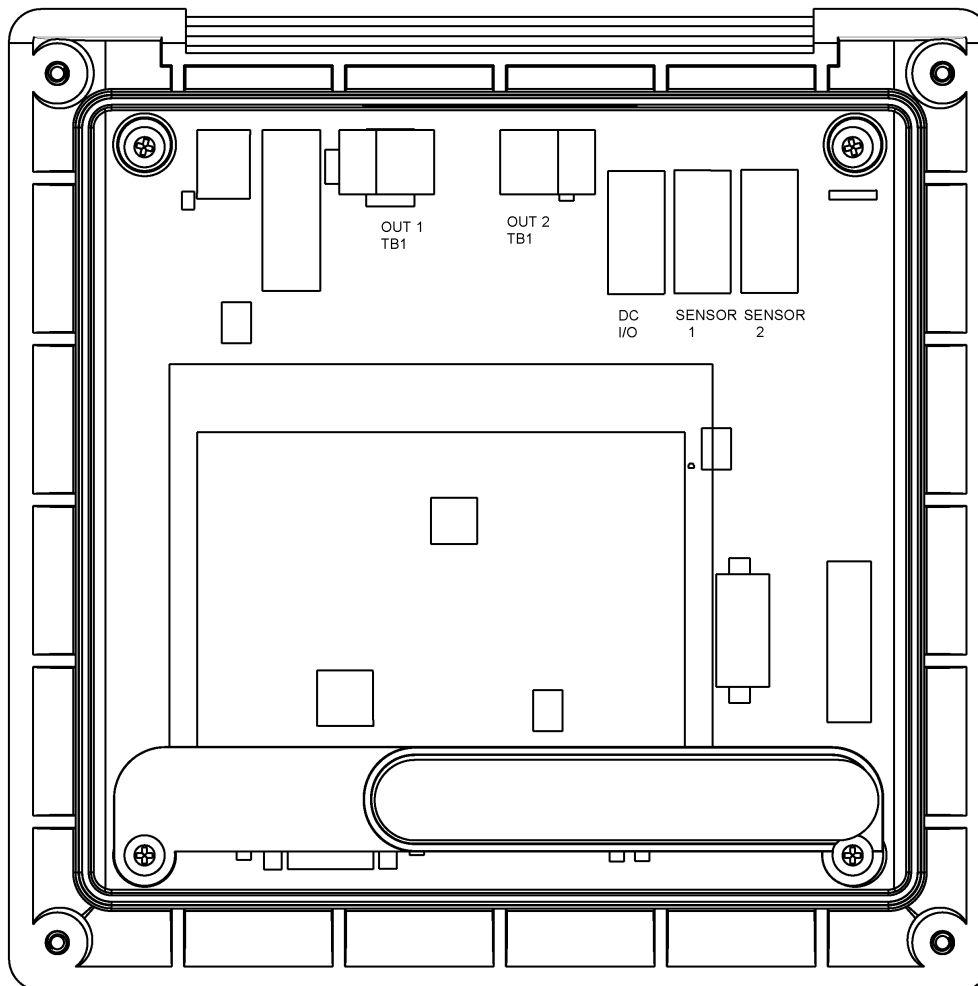

The analog outputs are on the main board near the hinged end of the enclosure door.

For best electromagnetic interference/radio frequency interference (EMI/RFI) protection, use shielded output signal cable enclosed in earth-grounded metal conduit.

Keep output signal wiring separate from power wiring. Do not run signal and power or relay wiring in the same conduit or close together in a cable tray.

2.3 Alarm wiring

The alarm relay terminal strip is located just below the power connector on the power supply board.

See [Alarm relay connections](#).

Figure 2-2: Alarm relay connections

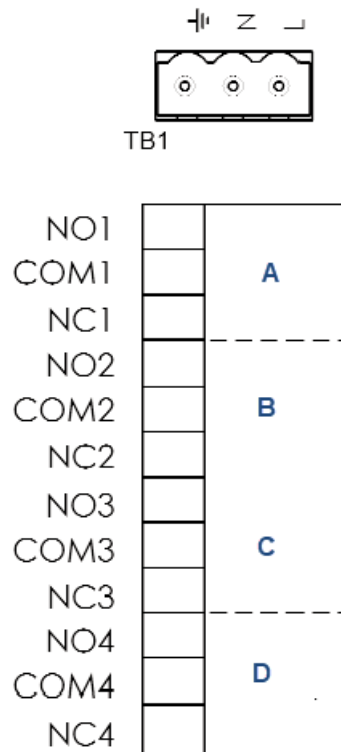

- A. Alarm relay 1
- B. Alarm relay 2
- C. Alarm relay 3
- D. Alarm relay 4

Keep alarm relay wiring separate from signal wiring. Do not run signal and power or relay wiring in the same conduit or close together in a cable tray.

2.4 Wire sensor

The Rosemount FCL is provided with sensor cables pre-wired to the transmitter. If it is necessary to replace the sensor cable, refer to the instructions below.

Procedure

1. Shut off power to the transmitter.
2. Loosen the four screws holding the front panel in place and let it drop down.
3. Locate the appropriate signal board.

Slot 1 (left)	Slot 2 (center)	Slot 3 (right)
Communication	Input 1 (chlorine)	Input 2 (optional)

4. Loosen the gland fitting and carefully push the sensor cable up through the fitting as you pull the board forward to gain access to the wires and terminal screws.

- Wire the sensor to the signal board.
Refer to the wiring diagrams in [Figure 2-3](#) and [Figure 2-4](#).

Figure 2-3: Wiring diagram for free chlorine sensor

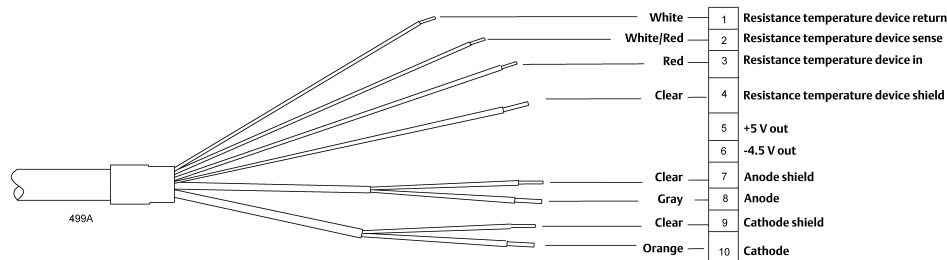

Table 2-1: Wiring diagram for free chlorine sensor

Terminal slot	Wire color	Wire function
1	White	Resistance temperature device return
2	White/red	Resistance temperature device sense
3	Red	Resistance temperature device in
4	Clear	Resistance temperature device shield
5	N/A	+5 V out
6	N/A	-4.5 V out
7	Clear	Anode shield
8	Gray	Anode
9	Clear	Cathode shield
10	Orange	Cathode

Connect green wire to metal conduit ground plate in bottom of enclosure.

Figure 2-4: Wiring diagram for 3900VP-10 pH Sensor (blue cable)

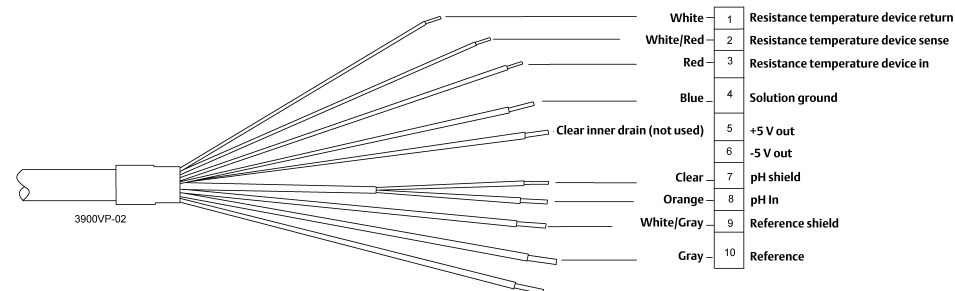

Table 2-2: Wiring diagram for 3900VP-10 pH Sensor (blue cable)

Terminal slot	Wire color	Wire function
1	White	Resistance temperature device return
2	White/red	Resistance temperature device sense

Table 2-2: Wiring diagram for 3900VP-10 pH Sensor (blue cable) (continued)

Terminal slot	Wire color	Wire function
3	Red	Resistance temperature device in
4	Blue	Solution ground
5	Clear inner drain (not used)	+5 V out
6	N/A	-5 V out
7	Clear shield	pH shield
8	Orange	pH In
9	Clear	Reference shield
10	Gray	Reference

Green (connect to green grounding screw at bottom of enclosure).

6. Once the cable has been connected to the board, slide the board fully into the enclosure while taking up the excess cable through the cable gland.
7. Tighten the gland nut to secure the cable and ensure a sealed enclosure.

2.5 Use Quick Start

Procedure

1. Once connections are secured and verified, apply power to the transmitter. When the transmitter is powered up for the first time, **Quick Start** screens appear. Using **Quick Start** is easy.
 - a. A backlit field shows the position of the cursor.
 - b. To move the cursor left or right, use the keys to the left or right of the **ENTER** key. To scroll up or down or to increase or decrease the value of a digit, use the keys above and below the **ENTER** key. Use the left and right keys to move the decimal point.
 - c. Press **ENTER** to store a setting. Press **EXIT** to leave without storing changes. Pressing **EXIT** also returns the display to the initial **Quick Start** screen.
 - d. A vertical black bar with a downward pointing arrow on the right side of the screen means there are more items to display. Continue scrolling down to display all the items. When you reach the bottom of the list, the arrow points up.

2. Choose the desired language. Scroll down to display more choices.

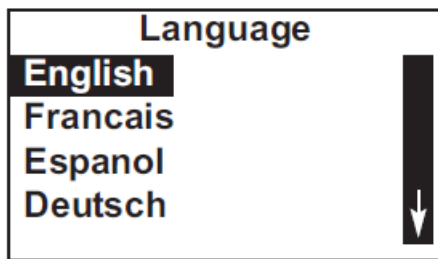

3. Choose Free Chlorine for sensor 1 (S1).

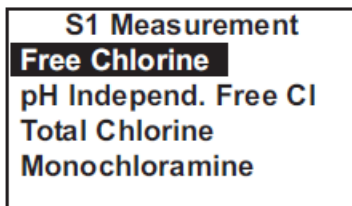

4. Choose the desired units for chlorine.

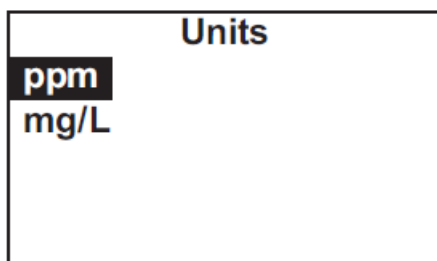

The screens in [Step 5](#) and [Step 6](#) only appear if you have a Rosemount FCL-02.

5. If you have a FCL-01, go to [Step 8](#). Otherwise, choose pH for Sensor 2 (S2).

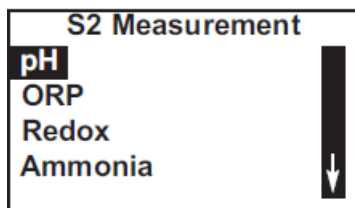

6. Choose Analyzer.

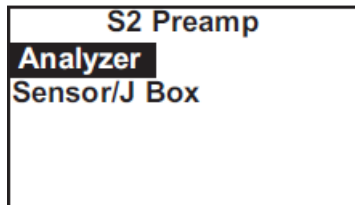

7. Choose **Live/Continuous**. Go to [Step 9](#).

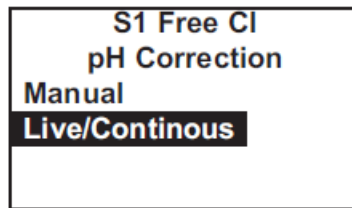

8. The screen below appears only if you have an FCL-01. Enter the pH of the process liquid.

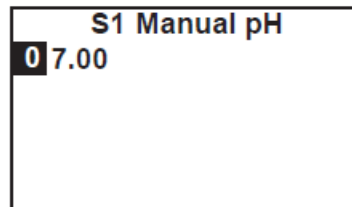

9. Choose the desired temperature units.

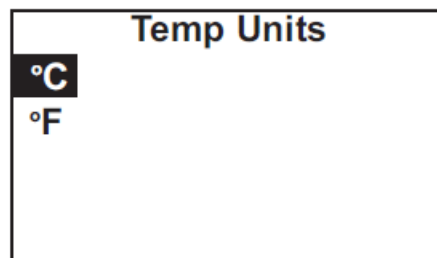

The main display appears. The outputs and alarms (if an alarm board is present) are assigned to default values.

10. To change outputs, alarms, and other settings, go to the **Main Menu** and choose **Program**. Follow the prompts.

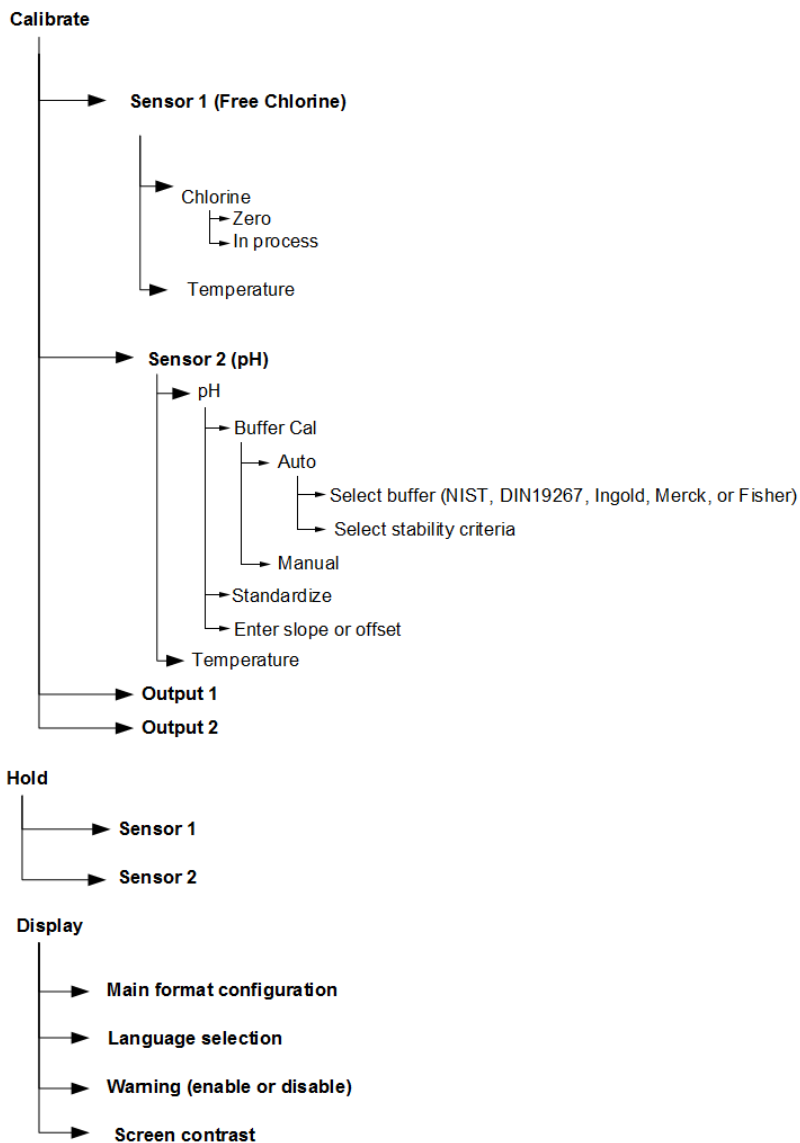

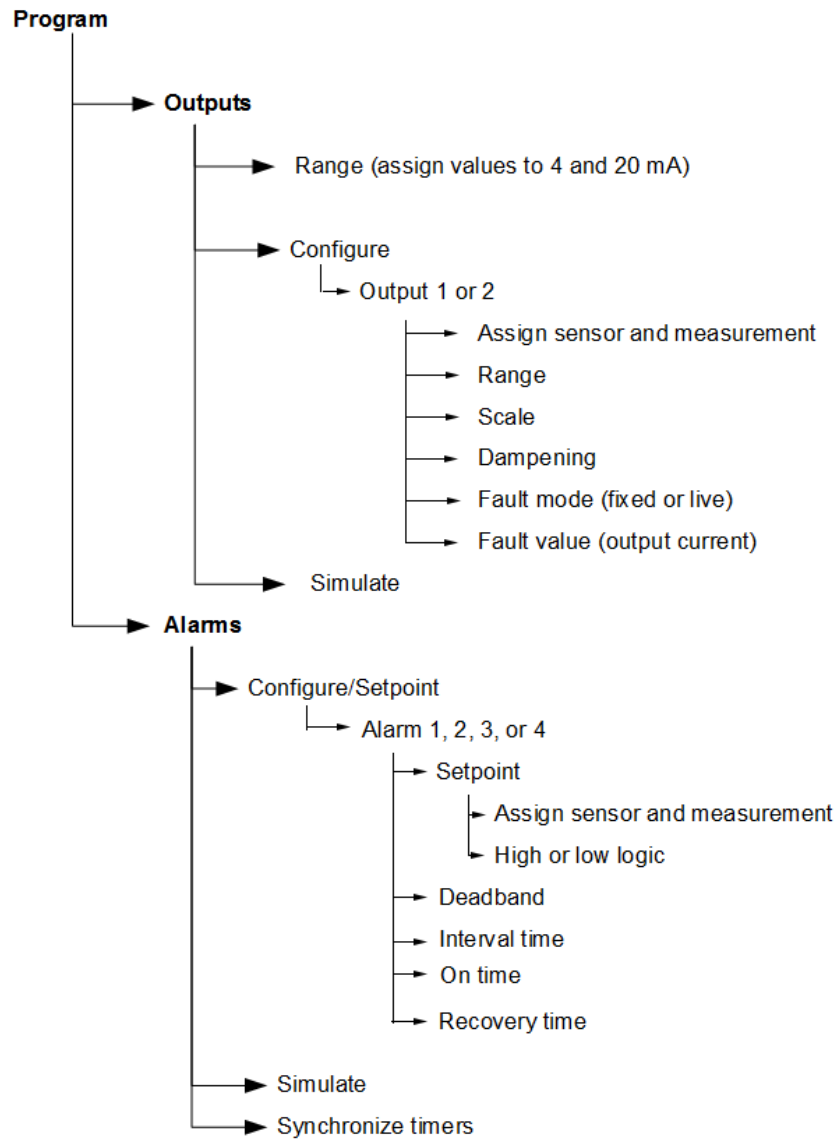

Program (continued)

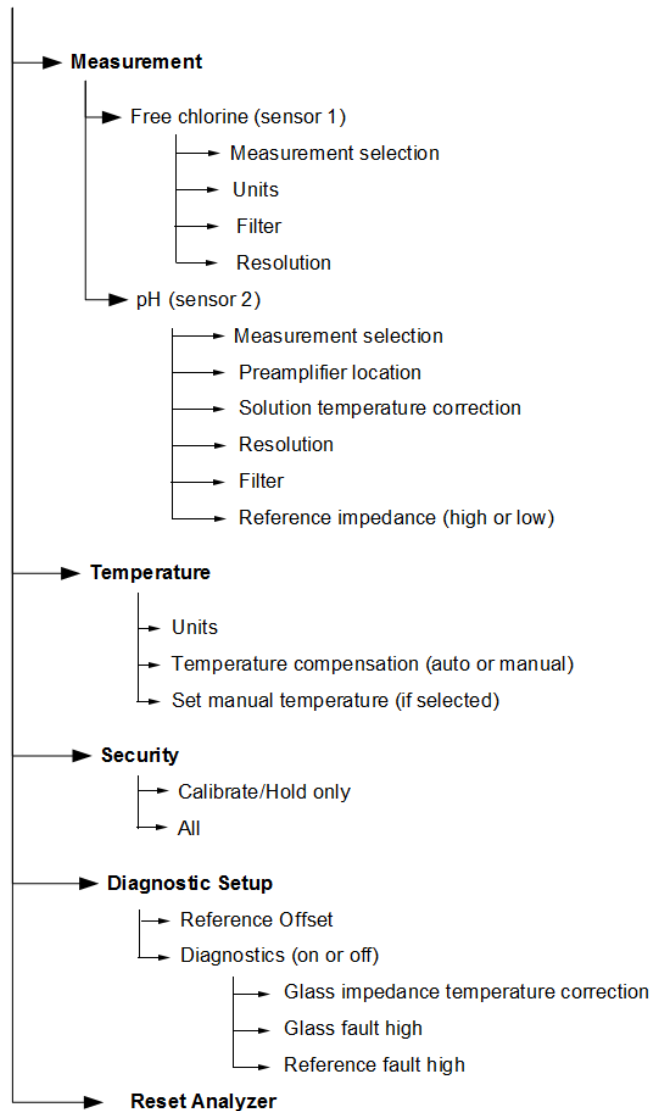

3 Display and operation

3.1 Display

The transmitter has a four line display.

See [Figure 3-1](#). You can customize the display to meet your requirements. Refer to [Configure the main display](#).

Figure 3-1: Main display

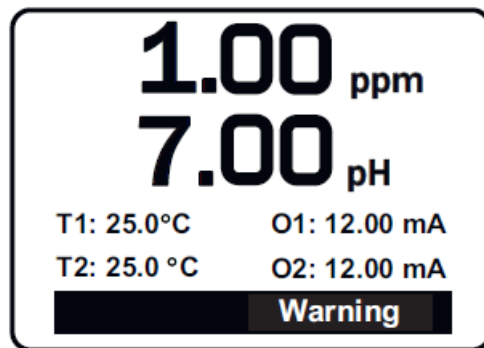

When the transmitter is being programmed or calibrated, the display changes to a screen similar to the one shown in [Figure 3-2](#). The live readings appear in small font at the top of the screen. The rest of the display shows programming and calibration information. Programming items appear in lists. The screen can only show four items at a time, and the arrow bar at the right of the screen indicates whether there are additional items in the list. See [Figure 3-3](#) for an explanation of the arrow bar.

Figure 3-2: Programming screen showing item list

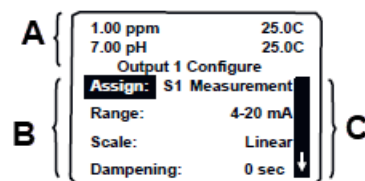

- A. Live measurement
- B. Item list
- C. Arrow bar

The position of the cursor is shown in reverse video. See [Keypad](#) and [Program the transmitter](#) for more information.

Figure 3-3: Arrow bar



- A. You are at the top of the list. There are more items for viewing. Scroll down.
- B. You are at the bottom of the list. There are more items for viewing. Scroll up.
- C. You are in the middle of the list. There are more items for viewing. Scroll up or down.

The arrow bar shows whether additional items in a list are available.

3.2 Keypad

Local communication with the transmitter is through the membrane keypad.

Figure 3-4 and Figure 3-5 explain the operation of the keys.

Figure 3-4: Transmitter keypad

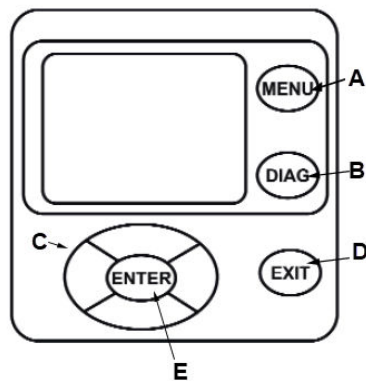

- A. Press **MENU**. The **Main Menu** screen appears.
- B. Press **DIAG**. The main diagnostic screen appears.
- C. Navigation keys move the cursor in the direction indicated in Figure 3-5.
- D. Press **EXIT** to leave a screen without storing changes. The display returns to the previous screen.
- E. Press **ENTER** to store a change or select an item. The display changes to the next screen.

Four navigation keys move the cursor around the screen. The position of the cursor is shown in reverse video. The navigation keys are used to increase or decrease the value of a numeral. Press **ENTER** to select an item and store numbers and settings. Press **EXIT** to return to the previous screen without storing changes. Pressing **MENU** always causes the main menu to appear.

Figure 3-5: Navigation keys

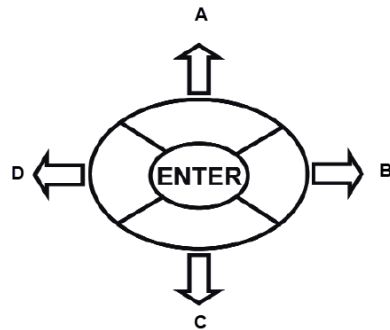

- A. Moves cursor up or increases the value of the selected digit.
- B. Moves cursor to the right.
- C. Moves cursor down or decreases the value of the selected digit.
- D. Moves cursor to the left.

The operation of the navigation keys is shown. To move a decimal point, highlight it and then press **Up** or **Down**.

3.3 Program the transmitter

Setting up and calibrating the transmitter is easy. The following tutorial describes how to move around in the programming menus. For practice, the tutorial also describes how to assign ppm chlorine values to the 4 and 20 mA analog outputs.

Procedure

1. Press **MENU**.
The main **Menu** screen appears. There are four items in the main menu. Calibrate is in reverse video, meaning that the cursor is on Calibrate.

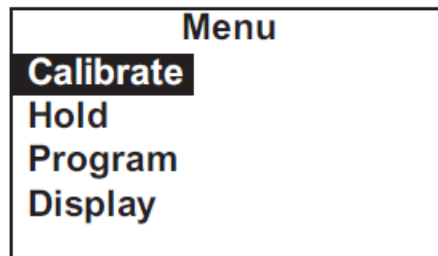

- To assign values to the analog outputs, open the `Program` sub-menu. Use **Down** to move the cursor to `Program`. Press **ENTER**.
The **Program** menu appears. There are between five and seven items in the **Program** menu. `Diagnostic Setup` appears only if you have the Rosemount FCL-02 with pH sensor. The screen displays four items at a time. The downward pointing arrow on the right of the screen shows there are more items available in the menu.

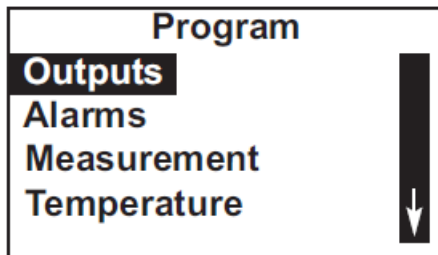

- To view the other items, use **Down** to scroll to the last item shown and continue scrolling down. When you have reached the bottom, the arrow will point up. Move the cursor back to `Outputs` and press **ENTER**.
The **Outputs** screen appears. The cursor is on `Range`. Output range is used to assign values to the low and high current outputs.

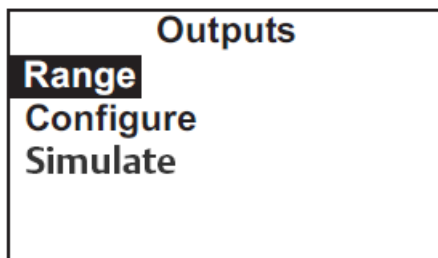

- Press **ENTER**.
The **Output Range** screen appears. The screen shows the present values assigned to output 1 (O1) and output 2 (O2). The screen also shows which sensors the outputs are assigned to. S1 is sensor 1. The assignments shown are the defaults for the FCL-01. Outputs are freely assignable under the **Configure** menu.

Output Range	
O1 S1 4mA	0.000 ppm
O1 S1 20mA:	10.00 ppm
O2 S1 4mA:	0.0C
O2 S1 20mA:	100.0C

5. For practice, change the 20 mA settings for output 1 to 8.5 ppm.
- Move the cursor to the O1 S1 20 mA: 10.00 line and press **ENTER**. The screen below appears.

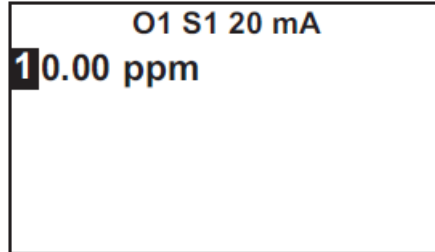

The screenshot shows a rectangular display area. At the top, it reads "O1 S1 20 mA". Below that, it reads "10.00 ppm". A black cursor bar is positioned over the first digit "1".

- Use the navigation keys to change 10.00 to 8.5 ppm. Use **Left** and **Right** to move from digit to digit. Use **Up** and **Down** to increase or decrease the numeral.
- To move the decimal point, press **Left** or **Right** until the decimal point is highlighted. Press **Up** to move the decimal point to the right. Press **Down** to move to the left.
- Press **ENTER** to store the setting.

The display returns to the summary screen shown below. Note that the 20 mA setting for output 1 has changed to 8.50 ppm.

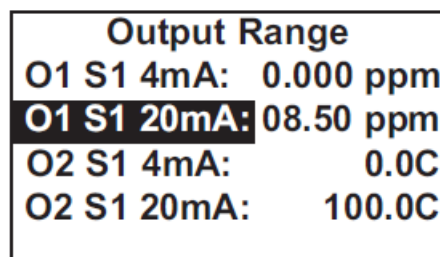

The screenshot shows a rectangular display area with the title "Output Range" at the top. Below the title, there are four lines of text: "O1 S1 4mA: 0.000 ppm", "O1 S1 20mA: 08.50 ppm", "O2 S1 4mA: 0.0C", and "O2 S1 20mA: 100.0C". The second line is highlighted with a black background.

- To return to the main menu, press **MENU**. To return to the main display, press **MENU** and then **EXIT**.

3.4 Security

3.4.1 How the security code works

Security codes prevent accidental or unwanted changes to program settings or calibrations. There are three levels of security.

- A user can view the default display and **Diagnostic** screens only.
- A user has access to the **Calibration** and **Hold** menus only.
- A user has access to all menus.

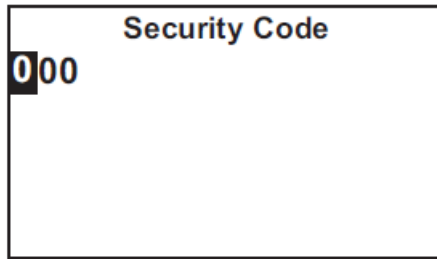

1. If a security code has been programmed, pressing **MENU** causes the **Security Code** screen to appear.
2. Enter the three-digit security code.
3. If the entry is correct, the main **Menu** screen appears. The user has access to the sub-menus the code entitles them to.
4. If the entry is wrong, the **Invalid code** screen appears.

3.4.2 Assign security codes

See [Configuring security settings](#).

3.4.3 Bypass security codes

Call the factory.

3.5 Using hold

3.5.1 Purpose of hold

To prevent unwanted alarms and improper operation of control systems or dosing pumps, place the alarms and outputs assigned to the sensor in hold before removing it for maintenance.

Hold is also useful if calibration will cause an out of limits condition. During hold, outputs assigned to the sensor remain at the last value, and alarms assigned to the sensor remain in their present state.

Once in hold, the sensor remains in hold until hold is turned off. However, if power is lost and then restored, hold is automatically turned off.

3.5.2 Put transmitter in hold

Procedure

1. Press **MENU**.
The main **Menu** screen appears.

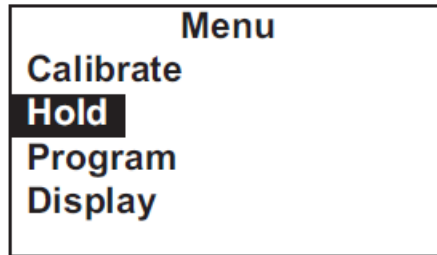

2. Select **Hold**.
The screen shows the current hold status for each sensor.

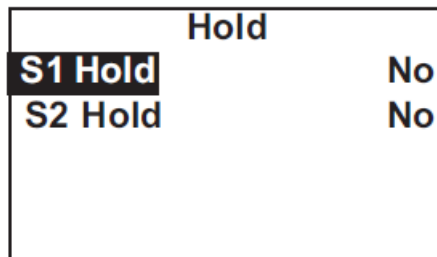

3. Select the sensor to be put in hold. Press **ENTER**.

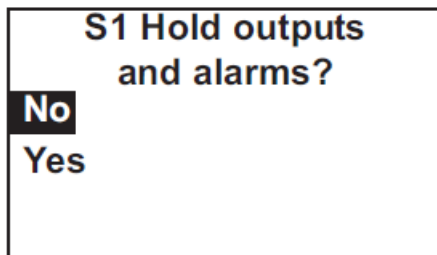

4. To put the sensor in hold, select **Yes**. To take the sensor out of hold, select **No**.

3.6 Configure the main display

You can configure the main display to meet your requirements.

Procedure

1. Press **MENU**.
The main **Menu** screen appears.

2. Move the cursor to **Display** and press **ENTER**.
The screen shows the present configuration. There are four items:
 - Main Format
 - Language
 - Warning
 - Contrast

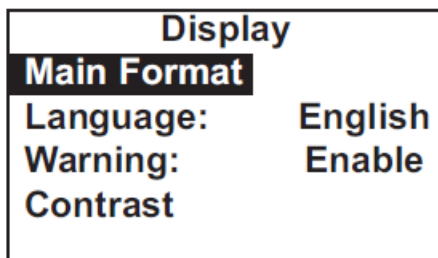

3. To make a change, move the cursor to the desired line and press **ENTER**.
A screen appears in which the present setting can be edited.
4. Press **ENTER** to store the setting.
5. **Main Format** lets you configure the second line in the main display as well as the four smaller items at the bottom of the display. Move the cursor to the desired place in the screen and press **ENTER**.

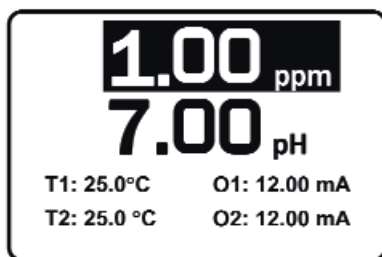

6. Scroll through the list of items and select the parameter you wish to be displayed.
7. Once you are done making changes, press **EXIT** twice to return to the **Display** menu.
8. Press **MENU** and then **EXIT** to return to the main display.

The following abbreviations are used in the quadrant display:

O	Output
T	Temperature (live)
Tm	Temperature (manual)
M	Measurement
mV	mV (pH)
I	Sensor current (chlorine)
Slp	Slope
GI	Glass impedance (pH)
RZ	Reference impedance (pH)

If you have a dual input Rosemount 1056 Transmitter, other abbreviations might appear. Consult the [Rosemount 1056 Transmitter Manual](#) for more details.

9. Choose `Language` to change the language used in the display.
10. Choose `Warning` to disable or enable warning messages.
11. Choose `Contrast` to change the display contrast.
12. To change the contrast, choose either lighter or darker and press **ENTER**. Every time you press **ENTER**, the display becomes lighter or darker.

4 Programming the transmitter

4.1 Programming overview

This section describes how to make the following program settings using the local keypad.

1. Configure and assign values to the analog current outputs.
2. Configure and assign values to the alarm relays.
3. Choose the type of chlorine measurement being made. This step is necessary because the transmitter used with the Rosemount FCL can measure forms of chlorine other than free chlorine.
4. Choose temperature units and automatic or manual temperature correction for chlorine and pH (if a pH sensor is installed).
5. Set two levels of security codes.
6. Assign limits to diagnostic warnings (applies only if a pH sensor is installed).
7. Reset the transmitter to factory default settings.

4.2 Default settings

The transmitter leaves the factory with the default settings shown in [Table 4-1](#). You can change the settings to any value shown in the column labeled **Choices**.

Table 4-1: Default settings

Item	Choices	Default
Sensor assignment		
Sensor 1	Chlorine	Chlorine
Sensor 2	pH	pH
Outputs		
Assignments (if Rosemount FCL-01)		
a. Output 1	Chlorine, temperature	Chlorine
b. Output 2	Chlorine, temperature	Temperature
2. Assignments (if FCL-02)		
a. Output 1	Chlorine, pH, temperature	Chlorine
b. Output 2	Chlorine, pH, temperature	pH
3. Range	0-20 or 4-20 mA	4-20 mA
4. 0 or 4 mA setting		
a. Chlorine and pH	-9999 to +9999	0
b. Temperature	-999.9 to +999.9	0
5. 20 mA setting		
a. Chlorine	-9999 to +9999	10
b. pH	-9999 to +9999	14

Table 4-1: Default settings (continued)

Item	Choices	Default
c. Temperature	-999.9 to +999.9	0
6. Fault current (fixed)	0.00 to 22.0 mA	22.0 mA
7. Dampening	0 to 999 sec	0 sec
8. Simulate	0.00 to 22.00 mA	12.00 mA
Alarms		
1. Logic	high or low	AL1 low, AL2, 3, 4, high
2. Assignments		
a. AL1 and AL2	Chlorine, pH, temperature, fault, interval timer	Chlorine (sensor 1)
b. AL3 and AL4	Chlorine, pH, temperature, fault, interval timer	Temperature (sensor 1)
3. Deadband	0 to 9999	0
4. Interval timer settings		
a. Interval time	0.0 to 999.9 hr	24.0 hr
b. On time	0 to 999 sec	10 sec
c. Recovery time	0 to 999 sec	60 sec
Measurement		
a. Units	ppm or mg/L	ppm
b. Resolution	0.01 or 0.001	0.001
c. Input filter	0 to 999 sec	5 sec
2. pH (sensor 2)		
a. Pre-amplifier location	analyzer or sensor/junction box	analyzer
b. solution temperature correction	on or off	off
c. resolution	0.01 or 0.1	0.01
d. input filter	0 to 999 sec	5 sec
e. Reference impedance	low or high	low
Temperature related settings		
1. Units	°C or °F	°C
2. Temperature compensation	Automatic or manual	Automatic
Security code		
1. Calibrate/Hold	000 to 999	000
2. Program/Display	000 to 999	000
pH sensor diagnostic limits		
1. Reference offset	0 to 9999 mV	60 mV
2. Diagnostics	on or off	on
3. Glass impedance temperature correction	on or off	on

Table 4-1: Default settings (continued)

Item	Choices	Default
4. Glass fault (low impedance)	0 to 9999 MΩ	10 MΩ
5. Glass fault (high impedance)	0 to 9999 MΩ	1500 MΩ
6. Reference fault (high impedance)	0 to 9999 kΩ	40 kΩ
Calibration - pH		
1. Stabilization criteria		
a. Time interval	0 to 99 sec	10 sec
b. pH change	0.01 to 1.00 pH	0.02 pH
2. User-entered slope	0.00 to 99.99 mV/pH	59.16 mV/pH
3. User-entered offset	-999 to +999 mV	0 mV
Calibration - analog outputs		
1. 4 mA	0.000 to 22.000 mA	4.000 mA
2. 20 mA	0.000 to 22.000 mA	20.000 mA

4.3 Configuring, ranging, and simulating outputs

4.3.1 Purpose of configuring outputs

This section describes how to configure, range, and simulate the two analog current outputs.

Note

Configure the outputs first.

1. Configuring an output means:
 - a. Assigning a sensor and measurement (chlorine, pH, or temperature) to an output.
 - b. Selecting a 4-20 mA or 0-20 mA output.
 - c. Choosing a linear or logarithmic output.
 - d. Adjusting the amount of dampening on the analog current output.
 - e. Selecting the value the output current goes to if the transmitter detects a fault.
2. Ranging the outputs means assigning values to the low (0 or 4 mA) and high (20 mA) outputs.
3. Simulating an output means making the transmitter generate an output equal to the value you enter.

4.3.2 Output definitions

Analog current output	The transmitter provides either a continuous 4-20 mA or 0-20 mA output signal proportional to chlorine, temperature, or pH.
Assigning an output	Outputs can be assigned to any sensor and to either free chlorine or temperature.
Linear output	Linear output means the current is directly proportional to the value of the variable assigned to the output (chlorine, pH, or temperature).
Logarithmic output	Logarithmic output means the current is directly proportional to the common logarithm of the variable assigned to the output (chlorine, pH, or temperature).
Dampening	Output dampening smooths out noisy readings. It also increases response time. The time selected for output dampening is the time to reach 63 percent of the final reading following a step change. Output dampening does not affect the response time of the display.
Fault	The transmitter continuously monitors itself and the sensor(s) for faults. If the transmitter detects a fault, a fault message appears in the main display. At the same time, the output current goes to the value programmed in this section. There are two output fault modes: <i>fixed</i> and <i>live</i> . <i>Fixed</i> means the selected output goes to the previously programmed value (between 0.00 and 22.00 mA) when a fault occurs. <i>Live</i> means the selected output is unaffected when the fault occurs.
Ranging an output	The outputs are fully rangeable, including negative numbers. If the output is logarithmic, assigned values must be positive.

4.3.3 Configure outputs

Complete the following steps to configure the analog current outputs.

Procedure

1. Press **MENU**.
The main *Menu* screen appears.
2. Move the cursor to *Program* and press **ENTER**.
The cursor is on *Outputs*.

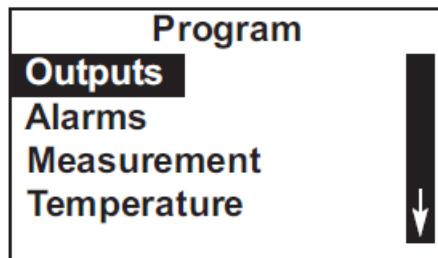

3. Press **ENTER**.

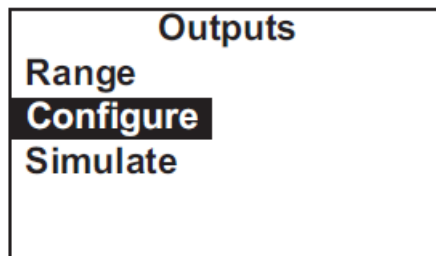

4. Choose *Configure*.

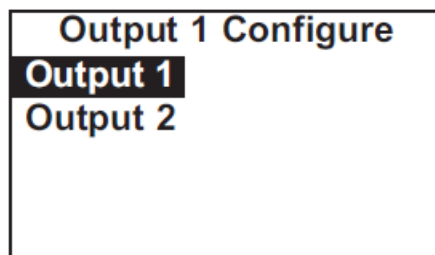

5. Choose **Output 1** or **Output 2**.
The screen shows the present configuration.

There are six items:

- Assign (S1 is sensor 1 and S2 is sensor 2)
- Range
- Scale
- Dampening
- Fault Mode
- Fault Value

To display the fifth and sixth items, scroll to the bottom of the screen and continue scrolling.

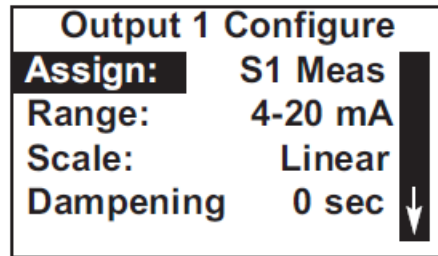

6. To make a change, move the cursor to the desired line and press **ENTER**.
A screen appears in which the present setting can be edited.
7. Press **ENTER** to store the setting.
For an explanation of terms, see [Purpose of configuring outputs](#) and [Definitions](#).
8. To return to the main display, press **MENU** and then **EXIT**.

4.3.4 Range outputs

Complete the following steps to range the outputs by assigning values to the low and high outputs.

Procedure

1. Press **MENU**.
The main **Menu** screen appears.
2. Move the cursor to **Program** and press **ENTER**.
The cursor is on **Outputs**.

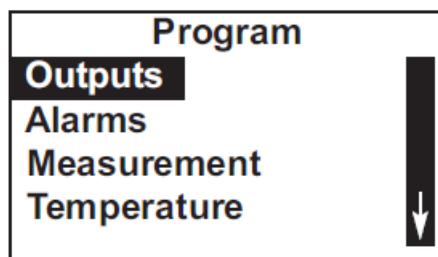

3. Press **ENTER**.

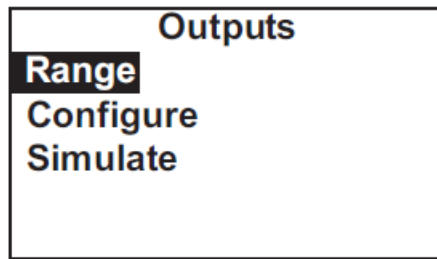

4. Choose Range.

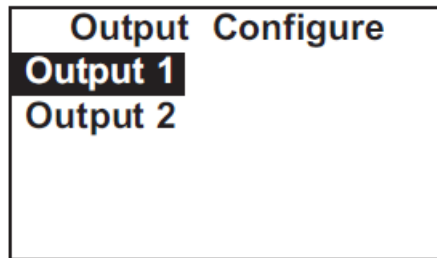

5. Choose Output 1 or Output 2.
The screen shows the present settings for the outputs. O1 is output 1, O2 is output 2, S1 is sensor 1, and S2 is sensor 2.

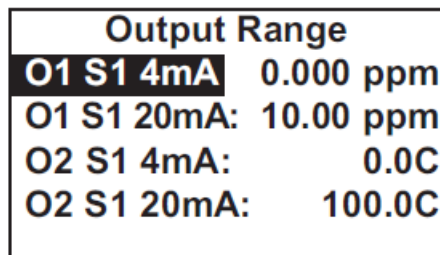

6. To make a change, move the cursor to the desired line and press **ENTER**.
A screen appears in which the present setting can be edited.
7. Press **ENTER** to store the setting.
For an explanation of terms, see [Purpose of configuring outputs](#) and [Output definitions](#).
8. To return to the main display, press **MENU** and then **EXIT**.

4.3.5 Simulate outputs

Complete the following steps to simulate an output by making the transmitter generate an output current equal to the value you enter.

Procedure

1. Press **MENU**.
The main **Menu** screen appears.

2. Move the cursor to **Program** and press **ENTER**.
The cursor is on **Outputs**.

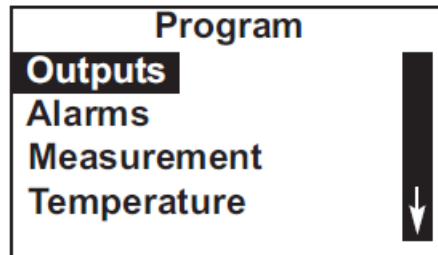

3. Press **ENTER**.

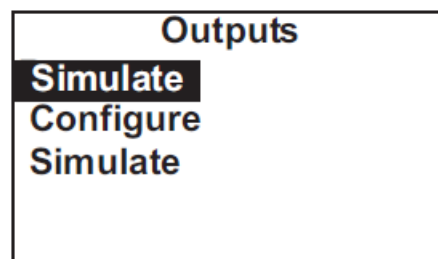

4. Choose **Simulate**.

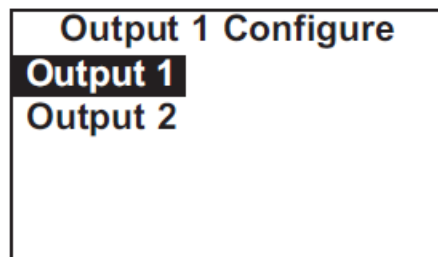

5. Choose **Output 1** or **Output 2**.

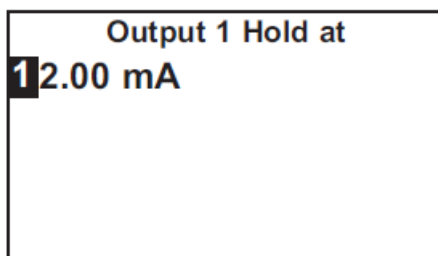

6. Enter the desired simulated output current.
7. To end the simulated current, press **MENU** or **EXIT**.

4.4 Configuring alarms and assigning setpoints

4.4.1 Purpose of configuring alarms and setpoints

This section describes how to configure and assign setpoints to the alarm relays, simulate alarm action, and synchronize interval timers.

Note

Configure the alarms first.

1. Configuring an alarm means:
 - a. Assigning a sensor and measurement (chlorine, pH, or temperature) to an alarm. An alarm relay can also be used as a timer.
 - b. Selecting high or low logic.
 - c. Choosing the deadband.
 - d. Setting the interval timer parameters.
2. Simulating an alarm means making the transmitter energize or de-energize an alarm relay.

4.4.2 Definitions of alarms and setpoints

Assigning alarms	There are four alarm relays. The relays are freely assignable to any sensor and to either the measurement (for example, chlorine) or temperature. Alarm relays can also be assigned to operate as interval timers or as fault alarms. A fault alarm activates when the transmitter detects a fault in either itself or the sensor.
Fault alarm	A fault condition exists when the transmitter detects a problem with the sensor or with the transmitter itself that is likely to cause seriously erroneous readings. If an alarm was programmed as a fault alarm, the alarm activates. At the same time, a fault message appears in the main display.
Alarm logic, setpoints, and deadbands	See Figure 4-1 and Figure 4-2 .

Figure 4-1: High alarm logic

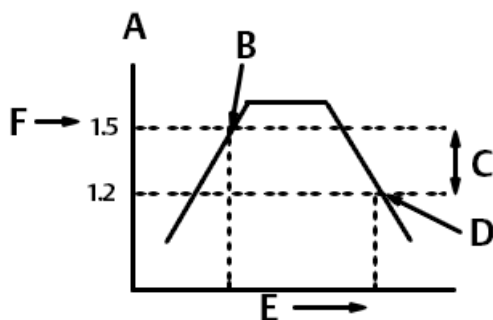

The alarm activates when the chlorine concentration exceeds the high setpoint. The alarm remains activated until the reading drops below the value determined by the deadband.

- A. Chlorine, ppm
- B. Alarm activates
- C. Deadband = 0.3 ppm
- D. Alarm deactivates
- E. Time
- F. High alarm setpoint

Figure 4-2: Low alarm logic

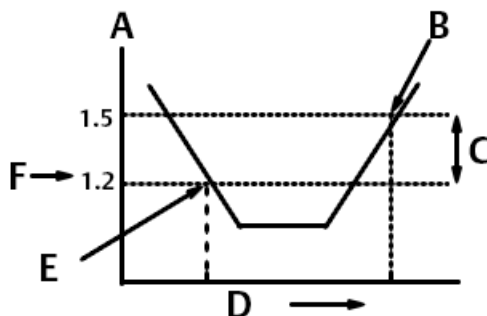

The alarm activates when the chlorine concentration drops below the low setpoint. The alarm remains activated until the reading increases above the value determined by the deadband.

- A. Chlorine, ppm
- B. Alarm deactivates
- C. Deadband = 0.3 ppm
- D. Time
- E. Alarm activates
- F. Low alarm setpoint

Interval timer Any alarm relay can be used as an interval timer. [Figure 4-3](#) shows how the timer operates. While the interval timer is operating, the main display, analog outputs, and assigned alarms for the sensor(s) can be put on hold. During hold, the main display remains at the last value.

Figure 4-3: Operation of the interval timer

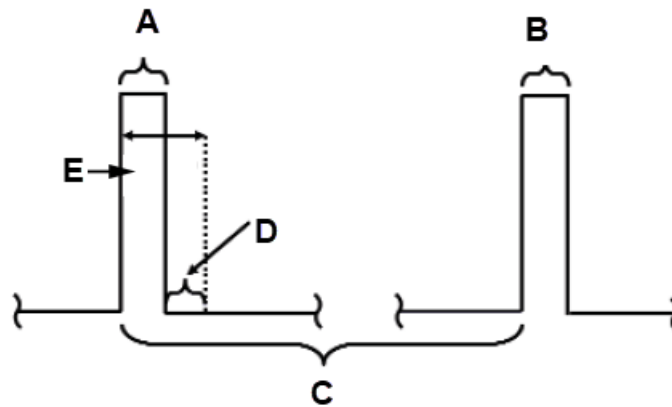

The numbers in parentheses are the allowed values for each timer parameter.

- A. On time duration (0 - 999 sec)
- B. On (relay activated)
- C. Timer interval (0 - 999.9 hr)
- D. Recovery (0 - 999 sec)
- E. Hold

Synchronize timer

If two or more relays are being used as interval timers, choosing synchronize timers will cause each timer to start one minute later than the preceding timer.

4.4.3 Configure alarms and assign setpoints

Procedure

1. Press **MENU**.
The main *Menu* screen appears.
2. Move the cursor to *Program* and press **ENTER**.
3. Choose *Alarms*.

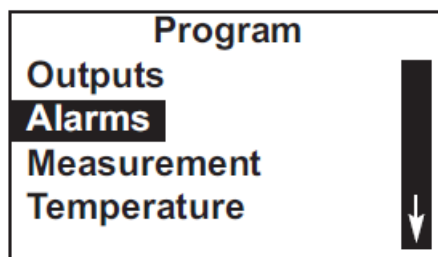

4. Choose **Configure/Setpoint**.

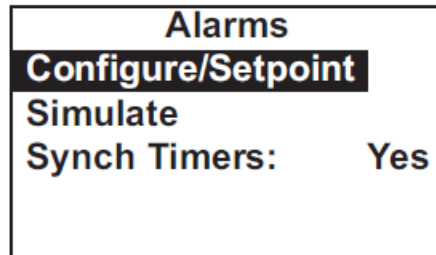

5. Choose **Alarm 1**, **Alarm 2**, **Alarm 3**, or **Alarm 4**.

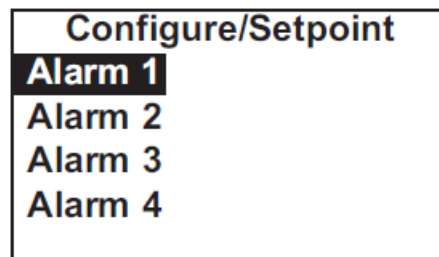

The screens summarize the present configuration and setpoints. There are eight items:

- Setpoint
- Assign (S1 is sensor 1, and S2 is sensor 2.)
- Logic
- Deadband
- Interval time
- On time
- Recover time
- Hold while active

The last four items describe the operation of the timer. Only four items are shown at a time. To view the remaining items, scroll to the bottom of the screen and continue scrolling.

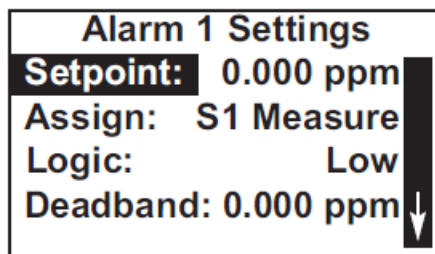

6. To make a change, move the cursor to the desired line and press **ENTER**. A screen appears in which the present setting can be edited.
7. Press **ENTER** to store the setting.

For an explanation of terms, see [Purpose of configuring alarms and setpoints](#) and [Definitions of alarms and setpoints](#).

8. To return to the main display, press **MENU** and then **EXIT**.

4.4.4 Simulate alarms

Complete the following steps to make the transmitter energize or de-energize an alarm relay.

Procedure

1. Press **MENU**.
The main *Menu* screen appears.
2. Move the cursor to *Program* and press **ENTER**.
3. Choose *Alarms*.

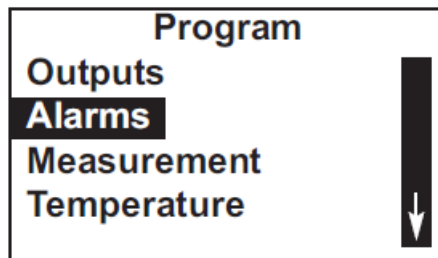

4. Choose *Simulate*.

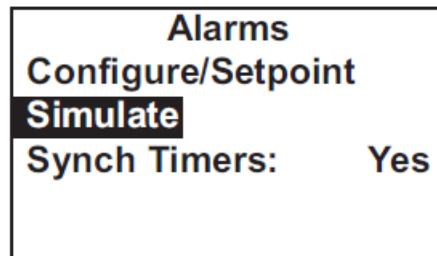

5. Choose Alarm 1, Alarm 2, Alarm 3, or Alarm 4.

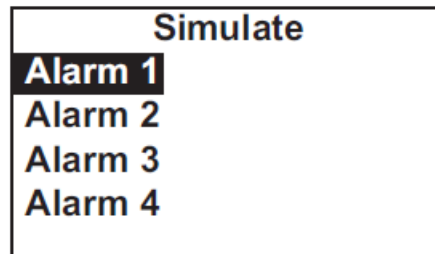

6. Choose Don't simulate, De-energize, or Energize.

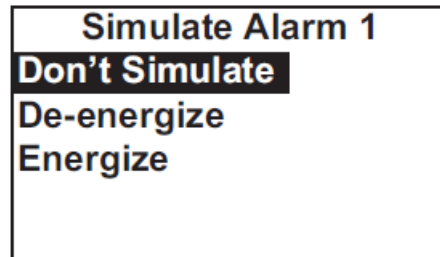

7. Press **MENU** or **EXIT** to end simulation.

4.4.5 Synchronize timers

`Synch timers` is available only if two or more alarm relays have been configured as interval timers.

Procedure

1. Press **MENU**.
The main *Menu* screen appears.
2. Move the cursor to `Program` and press **ENTER**.
3. Choose `Alarms`.

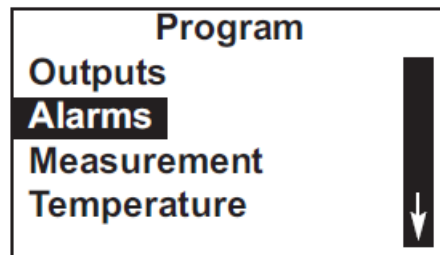

The summary display shows the current `Synch timers` setting (Yes or No).

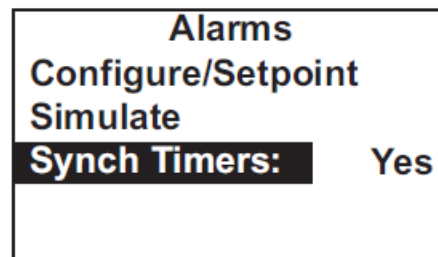

4. To make a change, choose `Synch timers` and press **ENTER**.
A screen appears in which the present setting can be edited.
5. Press **ENTER** to store the setting.
For an explanation of terms, see [Purpose of configuring alarms and setpoints](#) and [Definitions of alarms and setpoints](#).
6. To return to the main display, press **MENU** and then **EXIT**.

4.5 Configuring measurement

4.5.1 Purpose of configuring measurement

This section explains how to do the following:

1. Program the transmitter to measure free chlorine (and pH). This step is necessary, because the transmitter can be used with other sensors to measure other chlorine oxidants.
2. Set automatic or manual pH correction for the free chlorine measurement.
3. Set the level of electronic filtering of the raw signals from the chlorine and pH sensors.
4. Make various pH measurement settings. The transmitter supplied with the Rosemount FCL is designed to be as versatile as possible. The pH settings below are needed in some applications but are not used when pH is measured for the purpose of correcting free chlorine readings.
 - a. Solution temperature correction
 - b. Transmitter isopotential point

4.5.2 Chlorine definitions

Chlorine oxidants	Although the Rosemount FCL is used to measure free chlorine only, the transmitter used in the FCL can be used to measure other chlorine oxidants, for example, monochloramine and total chlorine.
Filter	The transmitter applies a software filter to the raw sensor current. The filter reduces noise but increases the response time. The available filter(s) depend on the time setting. If the filter is between 0 and 10 seconds, the transmitter applies a window filter. The window filter averages the measured value within the filter time. For example, if the filter is 5 seconds and a step increase is applied to the input, the displayed value increases linearly, reaching the final value after 5 seconds. If the filter is set to greater than 10 seconds, the transmitter applies either an adaptive filter or a continuous filter. An adaptive filter discriminates between noise and real process change. It filters changes below a fixed threshold value but does not filter changes that exceed the threshold. It is best used in situations where the noise is relatively low. A continuous filter dampens all changes. The filter timer setting is approximately equal to the time constant, the amount of time required for the reading to reach 63 percent of the final value following a step change.
pH correction	Free chlorine is the sum of hypochlorous acid (HOCl) and hypochlorite ion (OCl ⁻). The relative amount of each depends on pH. As pH increases, the concentration of HOCl decreases, and the concentration of OCl ⁻ increases. Because the sensor responds only to HOCl, a pH correction is necessary to properly convert the sensor current into a free chlorine reading. The FCL uses either continuous (live) or manual pH correction. In continuous (live) correction, the transmitter continuously monitors the pH of the sample and corrects the free chlorine readings for changes in pH. In manual pH correction, the transmitter uses the pH you enter for the pH correction. Generally, if the pH changes more than about 0.2 units over short periods of time, Emerson recommends continuous (live) pH correction. If the pH is

relatively steady or subject to only seasonal changes, manual pH correction is adequate.

Resolution If the chlorine concentration is less than 1.00 ppm (mg/L), the display resolution can be set to 0 . XX or 0 . XXX.

4.5.3 pH/ORP definitions

ORP	ORP is oxidation-reduction potential. It is the voltage difference between a noble metal indicator electrode (like platinum) and a silver/silver chloride reference electrode.
Redox	Redox is redox potential. It has the opposite sign from the ORP.
Preamplifier	The pH signal has a high impedance. Before it can be used, it must be converted into a low impedance signal. The preamplifier accomplishes this task, and it can be located in either the transmitter or the sensor. In the Rosemount FCL-02, the preamplifier is located in the transmitter.
Solution temperature correction	The pH of a solution, particularly an alkaline one, is a function of temperature. If the temperature changes, so will the pH, even though the concentration of the acid or base remains constant. Solution temperature compensation converts the pH at the measurement temperature to the pH at a reference temperature (77 ° F [25 °C]). Generally, solution temperature compensation is used only in the determination of pH in condensate, feedwater, and boiler water in steam electric power plants.
Resolution	The pH display resolution is user selectable: XX . X or XX . XX.
Filter	The transmitter applies a software filter to the raw voltage value coming from the pH sensor. The filter reduces noise, but increases the response time. See Chlorine definitions for more information.
Reference impedance	Usually, the impedance of the reference electrode in a pH sensor is low. However, a few pH sensors have high reference impedance, and the transmitter must be told that the reference impedance is high. The pH sensor used in the FCL-02 has low reference impedance.

4.5.4 Configure chlorine measurement

Complete the following steps to configure the transmitter to measure free chlorine.

Procedure

1. Press **MENU**.
The main **Menu** screen appears.
2. Move the cursor to `Program` and press **ENTER**.

3. Choose Measurement.

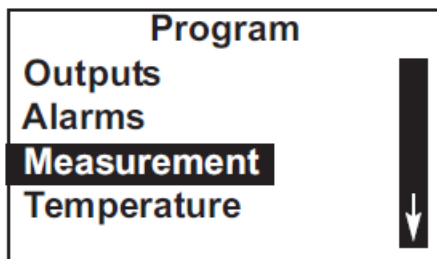

The screen below appears only if you have a Rosemount FCL-02.

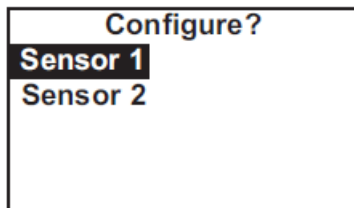

4. Choose *Sensor 1* (chlorine) or *Sensor 2* (pH).
The screen summarizes the present configuration for sensor 1 (chlorine). If you have an FCL-02, the items are *Measure*, *Units*, *Filter*, *Free Cl Correct*, and *Resolution*. If you have an FCL-01, the items are *Measure*, *Units*, *Filter*, *Manual pH*, and *Resolution*. Only four items are shown at a time. To view the remaining items, scroll to the bottom of the screen and continue scrolling.
5. To make a change, move the cursor to the desired line and press **ENTER**.
A screen appears in which the present setting can be edited.
6. To store the setting, press **ENTER**.
- a) For *Measurement*, choose *Free Chlorine*. Do not choose *pH Independent*.
Free Cl.
 - b) Leave *Filter* at the default value (5 sec) unless readings are noisy.
 - c) If you have an FCL-02, choose either *Live/Continuous* or *Manual* for *Free Cl Correct* (free chlorine correction).
Live/Continuous means the transmitter will use the pH measured on the second channel to continuously correct the chlorine reading for changes in the sample pH. *Manual* means the transmitter will use a fixed pH value entered by you to convert the raw chlorine signal to a ppm reading.
 - d) If you have an FCL-01, *Free Cl Correct* (free chlorine correction) will not appear. Instead, enter the desired pH correction value for *Manual pH*.
- The screen summarizes the present configuration for sensor 2 (pH). There are six items: *Measure*, *Preamp*, *Sol'n Temp Corr*, *Resolution*, *Filter*, and *Reference Z* (reference impedance). Only four items are shown at a time. To view the remaining items, scroll to the bottom of the screen and continue scrolling.
7. To make a change move the cursor to the desired line and press **ENTER**.
A screen appears in which the present setting can be edited.
8. To store the settings, press **ENTER**.
- a) For *pH Preamp*, choose *Analyzer*.

- b) For `pH Reference Z`, choose `Low`.
- c) Leave `Filter` at the default value unless readings are noisy.

For an explanation of terms, see [Chlorine definitions](#) and [pH/ORP definitions](#).

- 9. To return to the main display, press **MENU** and then **EXIT**.

4.6 Configuring temperature related settings

4.6.1 Purpose of temperature settings

This section describes how to do the following:

1. Choose temperature units.
2. Choose automatic or manual temperature correction for membrane permeability.
3. Choose automatic or manual temperature compensation for pH.
4. Enter a temperature for manual temperature compensation.

4.6.2 Chlorine temperature definitions

Automatic temperature correction

The free chlorine sensor is a membrane-covered amperometric sensor. It produces a current directly proportional to the rate of diffusion of free chlorine through the membrane. The diffusion rate, in turn, depends on the concentration of free chlorine in the sample and membrane permeability. Membrane permeability is a function of temperature. As temperature increases, permeability increases. Thus, an increase in temperature will cause the sensor current and the transmitter reading to increase even though the concentration of chlorine remained constant. In automatic temperature correction, the transmitter uses the temperature measured by the sensor to continuously correct for changes in membrane permeability.

Manual temperature correction

In manual temperature correction, the transmitter uses the temperature you enter for correction. It does not use the actual process temperature. Do not use manual temperature correction unless the measurement and calibration temperatures differ by no more than about 2 °C. Manual temperature correction is useful if the sensor temperature element has failed and a replacement sensor is not available.

4.6.3 pH temperature definitions

Automatic temperature compensation

A pH sensor produces a voltage that depends on the pH of the sample. The transmitter uses a temperature-dependent factor to convert the voltage to pH. In automatic temperature compensation, the transmitter uses the temperature measured by the pH sensor to calculate the conversion factor. For maximum accuracy, use automatic temperature compensation.

Manual temperature compensation

In manual temperature compensation, the transmitter converts measured voltage to pH using the temperature you enter. It does not use the actual process temperature. Do not use manual temperature compensation unless the process temperature varies no more than

about ± 2 °C. Manual temperature correction is useful if the sensor temperature element has failed and a replacement is not available.

4.6.4 Configure temperature related settings

Complete the following steps to set the temperature units and to select automatic or manual temperature correction.

Procedure

1. Press **MENU**.
The main *Menu* screen appears.
2. Move the cursor to `Program` and press **ENTER**.
3. Choose **Temperature**.

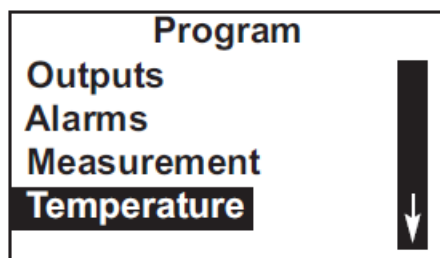

The screen summarizes the present sensor configuration.

There are between three and five items. `Units`, `S1 Temp Comp`, and `S2 Temp Comp` always appear. If manual temperature compensation was selected, the manual temperature values entered for each sensor (`S1 Manual` and `S2 Manual`) also appear.

4. To make a change, move the cursor to the desired line and press **ENTER**.
A screen appears in which the present setting can be edited.
5. To store a setting, press **ENTER**.
For an explanation of terms, see [Purpose of temperature settings](#), [Chlorine temperature definitions](#), and [pH temperature definitions](#).
6. To return to the main display, press **MENU** and then **EXIT**.

4.7 Configuring security settings

4.7.1 Purpose of security settings

This section describes how to set security codes. There are three levels of security.

1. A user can view the default display and diagnostic screens only.
2. A user has access to the calibration and hold menus only.
3. A user has access to all menus.

The security code is a three digit number. The table shows what happens when different security codes (`XXX` and `YYY`) are assigned to Calibration/Hold and All. `000` means no security.

Calibration/Hold	All	What happens
000	XXX	User enters XXX and has access to all menus.
XXX	YYY	User enters XXX and has access to Calibration and Hold menus only. User enters YYY and has access to all menus.
XXX	000	User needs no security code to have access to all menus.
000	000	User needs no security code to have access to all menus.

4.7.2 Configure security settings

Procedure

1. Press **MENU**.
The main **Menu** screen appears.
2. Move the cursor to **Program** and press **ENTER**.
3. Scroll to the bottom of the screen and continue scrolling until **Security** is highlighted. Press **ENTER**.

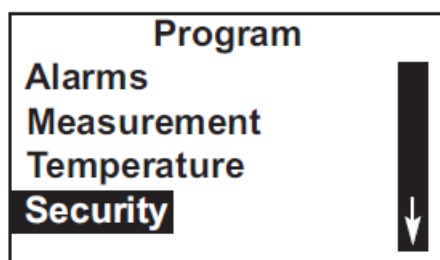

The screen shows the existing security codes.

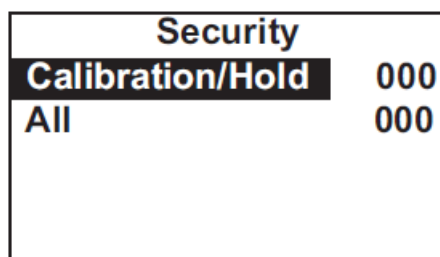

4. To make a change, move the cursor to the desired line and press **ENTER**.
A screen appears in which the present setting can be edited.
5. Press **ENTER** to store a change.
The security code takes effect two minutes after pressing **ENTER**.
6. To return to the main display, press **MENU** and then **EXIT**.

4.8 Setting up diagnostics

4.8.1 Purpose of diagnostic setup

Note

Diagnostic setup applies only to pH sensors. It appears only if you are using the Rosemount FCL-02.

This section describes how to do the following:

1. Turn pH sensor diagnostics on and off.
2. Set pH sensor diagnostic limits.

4.8.2 Diagnostics definitions

Diagnostics	pH sensor diagnostics are useful in troubleshooting calibration problems and in predicting when a pH sensor should be replaced. Diagnostics can also alert you that the sensor is no longer submerged in the process liquid.
Reference offset	pH sensors are designed to have a potential of 0 mV in pH 7 buffer. The reference offset is the actual potential (in mV) in pH 7 buffer. A new sensor typically has a reference offset of a few mV.
Glass and reference impedance	During operation, the transmitter continuously measures the impedance of the pH glass membrane. If the pH sensor has a solution ground, the transmitter also continuously measures the impedance of the reference junction. The Rosemount 3900VP pH sensor supplied with the FCL-02 has a solution ground. Glass and reference impedance measurements provide useful information about sensor health and cleanliness.
Glass impedance temperature correction	The impedance of a glass electrode is a strong function of temperature. As temperature decreases, the impedance increases. For glass impedance to be a useful indicator of sensor condition, the impedance must be corrected to a reference temperature.
Glass fault high	A typical glass electrode has an impedance of about 100 M Ω . As the sensor ages, glass impedance increases. Extremely high impedance (greater than about 1000 M Ω) implies the sensor is nearing the end of its life. High impedance may also mean that the sensor is not submerged in the process liquid.

4.8.3 Set up diagnostics

Complete the following steps to set up diagnostics on your Rosemount FCL-02 pH sensor.

Procedure

1. Press **MENU**.
The main *Menu* screen appears.
2. Move the cursor to `Program` and press **ENTER**.
3. Scroll to the bottom of the screen and continue scrolling until `Diagnostic Setup` is highlighted. Press **ENTER**.

Diagnostics are available only for pH sensors. In the FCL-02, the pH sensor is Sensor 2.

The screen summarizes the present diagnostic settings and limits. There are nine items. To show items beyond the first four in the list, scroll to the bottom of the list and continue scrolling.

4. To make a change, move the cursor to the desired line and press **ENTER**. A screen appears in which the present settings can be edited. Emerson recommends that you set the settings to the values in the table.

Setting	Default
Ref Offset	60 mV
Diagnostic	On
Z Temp Correct'n	On
GI Fault High	1000 MΩ
Ref Fault High	20 KΩ

5. To return to the main display, press **MENU** and then **EXIT**.

4.9 Resetting the transmitter

4.9.1 Purpose of resetting

This section describes how to clear user-entered values and restore default settings. There are three resets:

1. Resetting to factory default clears ALL user-entered settings, including sensor and analog output calibration, and returns ALL settings and calibration values to the factory defaults.
2. Resetting a sensor calibration to the default value clears user-entered calibration data for the selected sensor but leaves all other user-entered data unaffected.
3. Resetting the analog output calibration clears only the user-entered analog output calibration. It leaves all other user-entered settings unchanged.

4.9.2 Reset the transmitter

Procedure

1. Press **MENU**.
The main **Menu** screen appears.
2. Move the cursor to **Program** and press **ENTER**.

3. Scroll to the bottom of the screen and continue scrolling until `Reset Analyzer` is highlighted. Press **ENTER**.

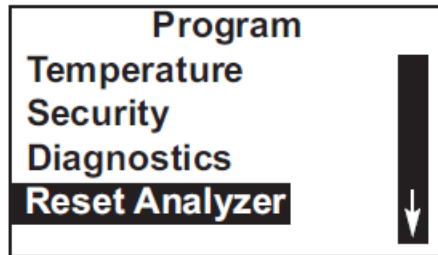

4. Choose whether to reset all user-entered values (`Factory Defaults`), sensor calibration (`Sensor Cal Only`), or output calibration (`Output Cal Only`).

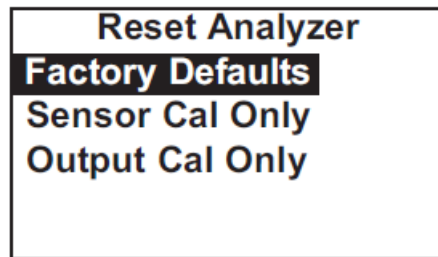

If you choose `Sensor Cal Only` or `Output Cal Only`, a second screen appears in which you can select which sensor or output calibration to reset.

5. To return to the main display, press **MENU** and then **EXIT**.

5 Calibration

5.1 Calibrate menu

The **Calibrate** menu allows you to do the following:

1. Calibrate the temperature sensing element in the chlorine and pH sensors.
2. Calibrate the pH sensor. Four methods are available:
 - a. Two-point calibration with automatic buffer recognition.
 - b. Manual two-point calibration.
 - c. Standardization.
 - d. Manual entry of pH sensor slope and offset.
3. Calibrate the chlorine sensor.
4. Calibrate the analog outputs.

5.2 Calibrate temperature

Temperature is important in the measurement of chlorine and pH for different reasons.

The free chlorine sensor is a membrane-covered amperometric sensor. As the sensor operates, free chlorine diffuses through the membrane and is consumed at an electrode immediately behind the membrane. The reaction produces a current that depends on the rate at which the free chlorine diffuses through the membrane. The diffusion rate, in turn, depends on the concentration of free chlorine and how easily it passes through the membrane (the membrane permeability). Because membrane permeability is a function of temperature, the sensor current changes if the temperature changes. To account for changes in sensor current caused by temperature alone, the transmitter automatically applies a membrane permeability correction. The membrane permeability changes about 3 percent per °C at 77 °F (25 °C), so a 1 °C error in temperature produces about a 3 percent error in the reading.

Temperature is also important in pH measurements.

1. The transmitter uses a temperature dependent factor to convert measured cell voltage to pH. Normally a slight inaccuracy in the temperature reading is unimportant unless the pH reading is significantly different from 7.00. Even then, the error is small. For example, at pH 12 and 25 °C (77 °F), a 1 °C error produces a pH error less than ± 0.02 .
2. During autocalibration, the transmitter recognizes the buffer being used and calculates the actual pH of the buffer at the measured temperature. Because the pH of most buffers changes only slightly with temperature, reasonable errors in temperature do not produce large errors in the buffer pH. For example, a 1 °C error causes at most an error of ± 0.03 in the calculated buffer pH.

Complete the following steps to calibrate the temperature in the transmitter.

Procedure

1. Remove the sensor from the flow cell. Place it in an insulated container of water along with a calibrated thermometer. Submerge at least the bottom 2 in. (25.4 mm) of the sensor.

2. Allow the sensor to reach thermal equilibrium.
The time constant for the sensor is about five minutes, so it may take as long as thirty minutes for equilibration.
3. Press **MENU**.
The main *Menu* screen appears. The cursor is on *Calibrate*.
4. Press **ENTER**.
5. Choose the sensor you wish to calibrate.
Sensor 1 is the chlorine sensor. *Sensor 2* (if present) is the pH sensor.
6. Choose *Temperature*.
7. Change the display to match the temperature read from the calibrated thermometer. Press **ENTER**.

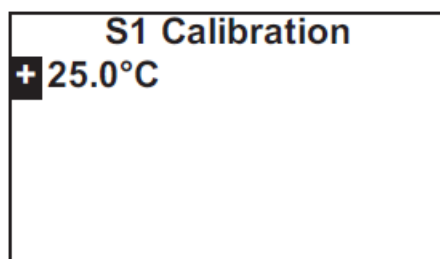

If the present temperature is more than 5 °C different from the value entered, an error message appears.

8. To force the transmitter to accept the calibration, choose *Yes*. To repeat the calibration, choose *No*.
For troubleshooting assistance, see [Troubleshooting when no error message is showing](#).
9. To return to the main display, press **MENU** and then **EXIT**.

5.3 Free chlorine calibration

5.3.1 Purpose of chlorine calibration

As [Figure 5-1](#) shows, a free chlorine sensor generates a current directly proportional to the concentration of free chlorine in the sample. Calibrating the sensor requires exposing it to a solution containing no free chlorine (zero standard) and to a solution containing a known amount of free chlorine (full-scale standard).

Note

A zero calibration is critical when attempting to measure near the limit of detection for the sensor. In a process measuring > 0.5 ppm, it may not be necessary

Figure 5-1: Sensor current as a function of free chlorine concentration

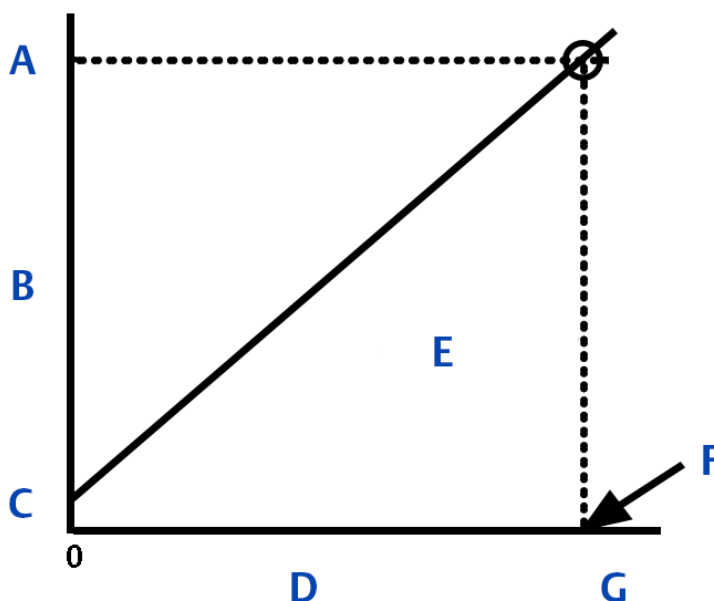

- A. $i_{full\ scale}$
- B. Sensor current
- C. i_{zero}
- D. Chlorine, ppm
- E. Slope = sensor current/ppm chlorine
- F. Full scale standard
- G. c_{std}

Any of the following makes a good zero standard:

- Commercially available bottled drinking water.

Note

Do not use distilled water

- Deionized water containing about 500 ppm sodium chloride. Dissolve about 0.5 grams ($\frac{1}{8}$ teaspoonful) of table salt in 1.1 quart (1 liter) of water.

Note

Do not use deionized water alone for zeroing the sensor. The conductivity of the zero water must be greater than 50 $\mu\text{S}/\text{cm}$.

- Tap water known to contain no chlorine. Expose tap water to bright sunlight for at least 24 hours.

The purpose of the full-scale standard is to establish the slope of the calibration curve. Because stable chlorine standards do not exist, the sensor must be calibrated against a test run on a grab sample of the process liquid. Several manufacturers offer portable test kits for this purpose. Observe the following standards when taking and testing the grab sample.

- Take the grab sample from a point as close to the Rosemount FCL as possible. Be sure that taking the sample does not alter the flow of the sample to the unit. The ideal

sample point would be from the drain of the FCL panel, or immediately downstream of the tap for the FCL.

- Chlorine solutions are unstable. Run the test immediately after taking the sample. Try to calibrate the sensor when the chlorine concentration is at the upper end of the normal operating range. Enter the grab sample value into the analyzer after the value has remained consistent for several sequential samples.

Free chlorine measurements also require a pH correction. Free chlorine is the sum of hypochlorous acid (HOCl) and hypochlorite ion (OCl⁻). The relative amount of each depends on pH. As pH increases, the HOCl decreases and concentration of OCl⁻ increases. Because the sensor responds only to HOCl, a pH correction is necessary to properly convert the sensor current into a free chlorine reading.

The sensor uses either continuous (live) or manual pH correction. In continuous (live) correction, the transmitter continuously monitors the pH of the sample and corrects the free chlorine reading for changes in pH. In manual pH correction, the transmitter uses the pH you enter for the pH correction. Generally, if the pH changes more than about 0.2 units over short periods of time, continuous (live) pH correction is recommended. If the pH is relatively steady or subject only to seasonal changes, manual pH correction is adequate.

During calibration, the transmitter must know the pH of the solution. If the transmitter is using automatic pH correction, the pH sensor (properly calibrated) must be in the process liquid before starting the calibration. If the transmitter is using manual pH correction, be sure to enter the pH value before starting the calibration.

5.3.2 Zero the chlorine sensor

Procedure

1. Place the sensor in the zero standard.

Be sure no air bubbles are trapped against the membrane.

The sensor current drops rapidly at first and then gradually reaches a stable zero value.

2. To monitor the sensor current, press **DIAG**.

3. Choose `Sensor 1`.

The input current is the first line in the display. Note the units: nA is nanoamps; μ A is microamps. Typical zero current for the new sensor is between -10 and 10 nA. A new sensor or a sensor in which the electrolyte solution has been replaced may require several hours (occasionally as long as overnight) to reach a minimum zero current.

Note

Do not start the zero routine until the sensor has been in the zero solution for at least two hours.

4. Press **MENU**.
The main **Menu** screen appears. The cursor is on `Calibrate`.
5. Press **ENTER**.

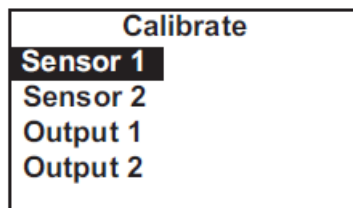

6. Choose the sensor you wish to calibrate.

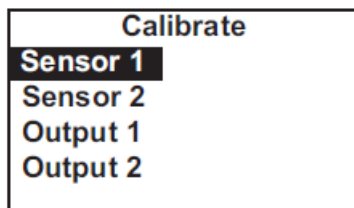

Sensor 1 is the chlorine sensor. Sensor 2 (if present) is the pH sensor.

7. Choose Free Chlorine.
8. Choose Zero Cal.

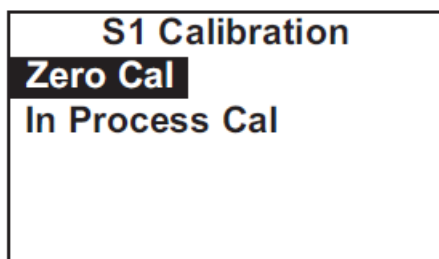

The transmitter automatically starts the zero calibration.

If the zero calibration was successful, then the following screen appears.

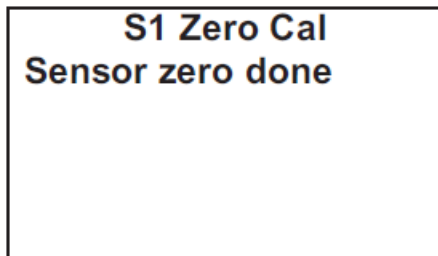

If the zero current is moderately larger than expected, then an error message appears.

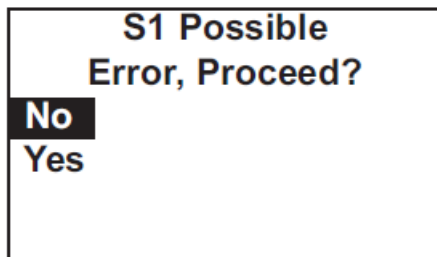

- To force the transmitter to accept the zero current, choose **Yes**. To repeat the calibration, choose **No**. For troubleshooting information, see [Troubleshooting when no error message is showing](#). If the zero current is much larger than expected, then the **Sensor zero failed** screen appears.

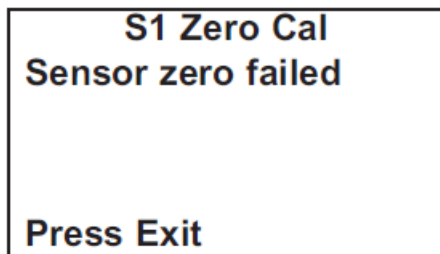

The transmitter will not update the zero current.

- To return to the main display, press **MENU** and then **EXIT**.

5.3.3 Calibrate the chlorine sensor

Procedure

- Place the chlorine sensor in the chlorine flow cell.
- If continuous (live) pH correction is being used, calibrate the pH sensor ([Autocalibrate pH sensor](#)) and place it in the pH flow cell. If manual pH correction is being used, measure the pH of the sample and enter the value. See [Configuring measurement](#).
- Adjust the chlorine concentration until it is near the upper end of the operating range. Wait until the transmitter reading is stable before starting calibration.
- Press **MENU**.
The main **Menu** screen appears. The cursor is on **Calibrate**.
- Press **ENTER**.
- Choose the sensor you wish to calibrate.

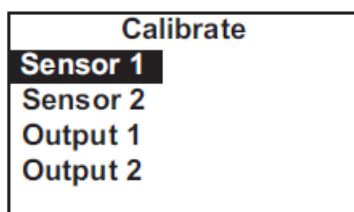

Sensor 1 is the chlorine sensor. Sensor 2 (if present) is the pH sensor.

- Choose **Free Chlorine**.

8. Choose In Process Cal.

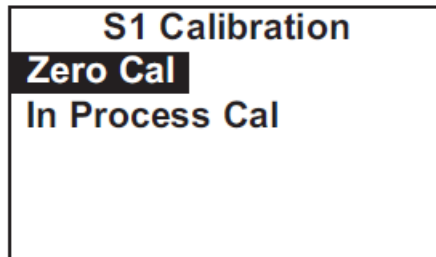

9. Follow the screen prompts. Once the reading is stable, press **ENTER**. Take the sample and press **ENTER**.
At this point, the transmitter stores the present sensor current and temperature and uses those values in calibration.
10. Determine the free chlorine concentration in the sample and enter the value in the screen below.

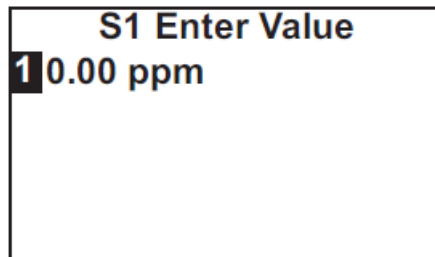

See [Purpose of chlorine calibration](#) for sampling and testing precautions.

If the calibration was successful, the live reading changes to the value entered in [Step 10](#), and the display returns to the screen in [Step 6](#). If the sensitivity is too far outside the range of expected values the following screen appears.

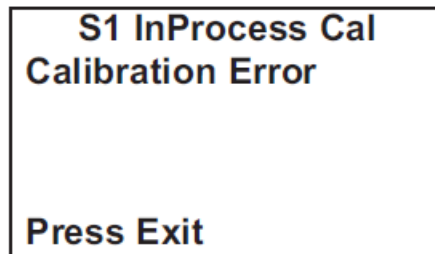

The transmitter doesn't update the calibration. For troubleshooting assistance, see [Troubleshooting when no error message is showing - chlorine](#).

11. To return to the main display, press **MENU** and then **EXIT**.

5.4 pH calibration

5.4.1 Purpose of pH calibration

A pH sensor consists of a glass and reference electrode. Usually, the two electrodes are combined into a single body, called a combination pH sensor.

When the sensor is placed in an aqueous solution, it produces a voltage proportional to pH. An ideal pH sensor has a potential of 0 mV in pH 7 solution and a slope of -59.16 mV/pH at 77 °F (25 °C), that is, a unit increase in pH causes the potential to drop 59.16 mV. However, even in a new pH sensor, the slope and offset are rarely equal to the ideal values. And, as the sensor ages, the offset typically increases, and the slope decreases. For these reasons, a new pH sensor should be calibrated before use, and the sensor should be recalibrated at regular intervals. A pH sensor is calibrated by exposing it to standard solutions having known pH values. The standard solutions are called buffers.

5.4.2 Definitions of pH calibration

Automatic buffer calibration In automatic buffer calibration, the transmitter recognizes the buffer and uses the temperature-corrected pH value in the calibration. [Table 5-1](#) lists the buffers the transmitter recognizes. Temperature-pH data are valid between at least +32 and +140 °F (0 and +60 °C).

Table 5-1: pH buffers

Buffer list	Buffer pH
Standard ⁽¹⁾	<ul style="list-style-type: none"> • 1.68 • 3.56 • 3.78 • 4.01 • 4.64 • 6.86 • 7.01 • 7.41 • 9.18 • 10.01 • 12.45
DIN19267	<ul style="list-style-type: none"> • 1.09 • 3.06 • 4.65 • 6.79 • 9.23 • 12.75

Table 5-1: pH buffers (continued)

Buffer list	Buffer pH
Ingold	<ul style="list-style-type: none"> • 1.993 • 4.005 • 7.002 • 9.206
Merck	<ul style="list-style-type: none"> • 2.002 • 4.014 • 7.003 • 9.004 • 12.009
Fisher	<ul style="list-style-type: none"> • 1.00 • 2.00 • 3.00 • 4.00 • 5.00 • 6.00 • 7.00 • 8.00 • 9.00 • 10.00 • 11.00

(1) With the exception of pH 7.01 buffer, the standard buffers are National Institute of Standards and Technology (NIST) buffers.

The transmitter also measures noise and drift and does not accept calibration data until readings are stable. Stability criteria are user-programmable.

The use of automatic buffer calibration minimizes errors, and Emerson strongly recommends its use.

Manual buffer calibration

In manual calibration, you must enter the pH value of the buffer at the temperature of the buffer. In addition, you must judge when pH readings are stable.

Slope and offset

Once the transmitter successfully completes the calibration, it calculates and displays the calibration slope and offset. The slope is reported at 77 °F (25 °C). [Figure 5-2](#) defines the terms.

Figure 5-2: Calibration slope and offset

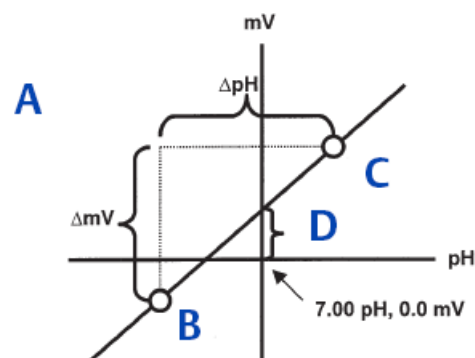

- A. Slope = $\Delta mV / \Delta pH$
- B. Buffer 1
- C. Buffer 2
- D. Offset

Standardization The pH measured by the transmitter can be changed to match the reading from a second or referee instrument. The process of making the two readings agree is called standardization. During standardization, the difference between the two pH values is converted to the equivalent voltage. The voltage, called the reference offset, is added to all subsequent measured sensor voltages before they are converted to pH. If a pH sensor is buffered, then standardized and placed back in the buffer solution, the measured pH will differ from the buffer pH by an amount equivalent to the standardization offset.

User entered slope and offset If the slope and offset are known from other measurements, they can be directly entered into the transmitter. Enter the slope as a positive number corrected to 77 °F (25 °C). To calculate the slope at 25 °C from the slope at temperature t °C, use the equation:

$$\text{slope at } 25 \text{ }^{\circ}\text{C} = (\text{slope at } t \text{ }^{\circ}\text{C}) \frac{298}{t \text{ }^{\circ}\text{C} + 273}$$

To calculate the offset, use the following equation. The offset can be either positive or negative.

$$\text{offset} = mV_{\text{buffer}} - (pH_{\text{buffer}} - 7.00)(\text{slope at } 25 \text{ }^{\circ}\text{C})$$

Stability setting During automatic calibration, the transmitter measures noise and drift and does not accept calibration data until readings are stable. Calibration data will be accepted as soon as the pH reading is constant to within the factory-set limits of less than 0.02 pH change in 10 seconds. The stability settings are programmable.

5.4.3 Autocalibrate pH sensor

Procedure

1. Obtain two buffer solutions.
Ideally, the buffer pH values should bracket the range of pH to be measured.

2. Remove the sensor from the flow cell. If the process and buffer temperatures are appreciably different, place the sensor in a container of tap water at the buffer temperature.
Do not start the calibration until the sensor has reached the buffer temperature.
3. Press **MENU**.
The main *Menu* screen appears. The cursor is on *Calibrate*.
4. Press **ENTER**.
5. Choose the sensor you wish to calibrate.
Sensor 1 is the chlorine sensor. *Sensor 2* is the pH sensor.
6. Choose *pH*.
7. Choose *Buffer Cal*.
8. Choose *Auto*.
9. Choose *Start Auto Cal*.
If you wish to change the stability criteria or the pH buffer list from the default values, choose *Setup* instead and go to [Step 16](#). The default stability is defined as a less than 0.02 change in 10 seconds. The default buffer list is *Standard*. See [Table 5-1](#).
10. Rinse the sensor with water and place it in the first buffer. Be sure the glass bulb and reference junction are completely submerged. Swirl the sensor.
11. Press **ENTER**.
Once the pH reading meets the stability requirements, the screen changes to show the nominal pH of the buffer. The nominal pH is the pH value at 77 °F (25 °C).
12. If the displayed value is not correct, press **Up** or **Down** until the correct value is showing.
13. Press **ENTER**.
Once the pH reading meets the stability requirements, the screen changes to show the nominal pH of the buffer.
14. If the displayed value is not correct, press **Up** or **Down** until the correct value is showing.
15. Press **ENTER**.
If the calibration is successful, a screen is displayed for five seconds. The display then returns to the screen in [Step 7](#). If the calibration is not successful, the existing calibration data is not changed. A screen appears identifying the error (high slope, low slope, or offset error). For troubleshooting, see [Troubleshooting when no error message is showing - pH](#). If you chose setup in [Step 9](#), the screen below appears.
16. To make a change, move the cursor to the desired line and press **ENTER**.
A screen appears in which the present setting can be edited.
17. Press **ENTER** to store the change.
18. To return to the main display, press **MENU** and then **EXIT**.

5.4.4 Calibrate pH sensor manually

Procedure

1. Obtain two buffer solutions.
Ideally, the buffer pH values should bracket the range of pH to be measured.

2. Remove the sensor from the flow cell. If the process and buffer temperatures are appreciably different, place the sensor in a container of tap water at the buffer temperature.
Do not start the calibration until the sensor has reached the buffer temperature.
3. Press **MENU**.
The main *Menu* screen appears. The cursor is on *Calibrate*.
4. Press **ENTER**.
5. Choose the sensor you wish to calibrate.
Sensor 1 is the chlorine sensor. *Sensor 2* is the pH sensor.
6. Choose pH.
7. Choose *Buffer Cal.*
8. Choose *Manual*.
9. Choose *Buffer 1*.
10. Rinse the sensor with water and place it in the first buffer. Be sure the glass bulb and reference junction are completely submerged. Swirl the sensor.
11. Watch the pH reading for sensor 2 (*S2*) at the top of the screen. Once the reading is stable, enter the pH value of the buffer at the buffer temperature and press **ENTER**. The display returns to the screen shown in [Step 9](#).
12. Choose *Buffer 2*.
13. Remove the sensor from the first buffer.
14. Rinse with water and place it in the second buffer. Be sure the glass bulb and reference junction are completely submerged. Swirl the sensor.
15. Press **ENTER**.
16. Watch the pH reading for sensor 2 (*S2*) at the top of the screen. Once the reading is stable, enter the pH value of the buffer at the buffer temperature and press **ENTER**. If the calibration is successful, a screen is displayed for five seconds. The display then returns to the screen in [Step 7](#). If the calibration is not successful, the existing calibration data is not changed. A screen appears identifying the error (high slope, low slope, or offset error). For troubleshooting, see [Troubleshooting when no error message is showing - pH](#).
17. To return to the main display, press **MENU** and then **EXIT**.

5.4.5 Standardize pH value

You can change the pH value measured by the transmitter to match the reading from a second or referee instrument. The process of making the two readings agree is called standardization.

Procedure

1. Place the sensor in the flow cell. Wait until pH readings are stable.
2. Press **MENU**.
The main *Menu* screen appears. The cursor is on *Calibrate*.
3. Press **ENTER**.
4. Choose the sensor you wish to calibrate.
Sensor 1 is the chlorine sensor. *Sensor 2* is the pH sensor.
5. Choose pH.

6. Choose **Standardize**.
7. Once the reading is stable, measure the pH of the liquid using a referee instrument. Because the pH of many natural and treated waters depends on temperature, measure the pH of the sample immediately after taking it. For poorly buffered samples, determine the pH of a continuously flowing sample from a point as close as possible to the sensor. Change the reading to match the reading of the referee instrument.
If the calibration is successful, a screen is displayed for five seconds. The display then returns to the screen in [Step 4](#). If the calibration is not successful, the existing calibration data is not changed. A screen appears identifying the error (high slope, low slope, or offset error). For troubleshooting, see [Troubleshooting when no error message is showing - chlorine](#).
8. To return to the main display, press **MENU** and then **EXIT**.

5.5 Calibrating analog outputs

5.5.1 Trimming analog outputs

Although Emerson calibrates the analog outputs at the factory, you can trim them in the field to match the reading from a standard milliammeter. You can trim both the low (0 or 4 mA) and high (20 mA) outputs.

5.5.2 Calibrate analog outputs

Procedure

1. Connect a calibrated milliammeter across the output you wish to calibrate. If a load is already connected to the output, disconnect the load.
Do not put the milliammeter in parallel with the load.
2. Press **MENU**.
The main **Menu** screen appears. The cursor is on **Calibrate**.
3. Press **ENTER**.
4. Choose the output you wish to calibrate.

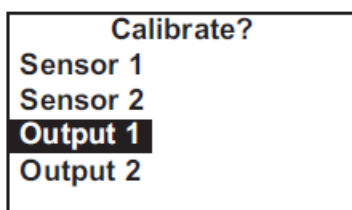

The transmitter simulates the low output current.

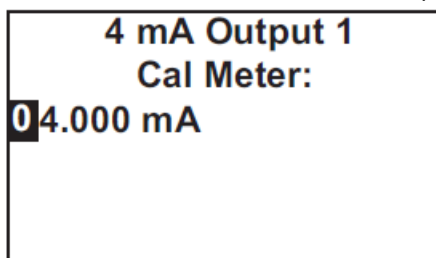

5. Change the value in the display to match the reading from the milliammeter. The transmitter simulates the 20 mA output current.

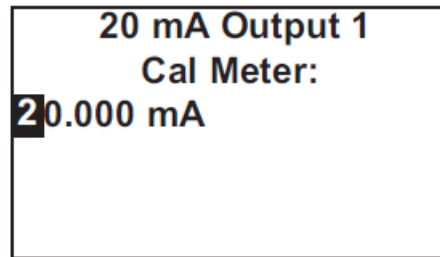

6. Change the value in the display to match the reading from the milliammeter. If the calibration was successful, the screen below appears.

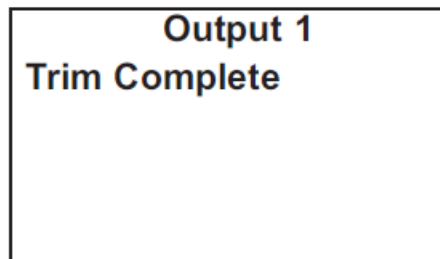

If the user entered value is more than ± 1 mA different from the nominal value, a possible error screen appears.

7. To force the transmitter to accept the calibration, choose **Yes**.
8. To return to the main display, press **MENU** and then **EXIT**.

6 Digital communications

The transmitter supplied with the Rosemount FCL does not have the digital communications option.

7 Maintenance

7.1 Replace sensor circuit board

The Rosemount 1056 transmitter used with the FCL requires little routine maintenance.

Clean the transmitter case and front panel by wiping with a clean soft cloth dampened with water only. Do not use solvents, like alcohol, that might cause a buildup of static charge.

Sensor circuit boards are replaceable.

PN	Description
24263-00	pH/ORP/ISE sensor board
24266-00	Chlorine sensor board

⚠ WARNING

Electrical shock

Disconnect main power and relay contacts to separate power source before servicing.

To replace the board:

Procedure

1. Turn off power to the transmitter.
2. Loosen the four screws holding the front panel in place and let the front panel drop down.
3. Loosen the gland fitting and carefully push the sensor cable up through the fitting as you pull out the circuit board.
4. Once you have access to the terminal strip, disconnect the sensor.
5. Unplug the sensor board from the main board.
See [Figure 2-2](#).
6. Slide the replacement board partially into the board slot. Plug the sensor board into the main board and reattach the sensor wires.
7. Carefully pull the sensor cable through the gland fitting as you push the sensor board back into the enclosure.
8. Close the front panel.
9. Turn on power.

7.2 Chlorine sensor

7.2.1 General

When used in clean water, the sensor requires little maintenance. Generally, the sensor needs maintenance when the response becomes sluggish or noisy or when readings drift following calibration.

Maintenance frequency is best determined by experience. For a sensor used in potable water, you may need to clean the membrane on a monthly basis and replace the

membrane and electrolyte solution every three months. In water containing large amounts of suspended solids, for example, open recirculating cooling water, membrane cleaning or replacement will be more frequent.

7.2.2 Clean the membrane

Clean the membrane with water sprayed from a wash bottle.

NOTICE

Do not use tissues to clean the membrane.

7.2.3 Replace the electrolyte solution and membrane

⚠ WARNING

Harmful substance

Fill solution may cause irritation. May be harmful if swallowed.

Read and follow the instructions.

Procedure

1. Unscrew the membrane retainer.

2. Remove the membrane assembly and O-ring.
See [Figure 7-1](#).

Figure 7-1: Chlorine sensor parts

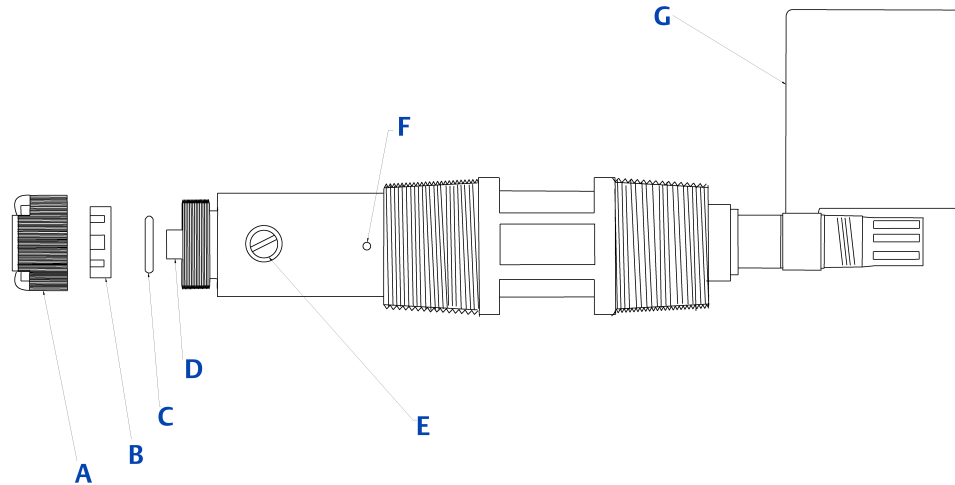

- A. Membrane retainer
- B. Membrane assembly
- C. O-ring
- D. Cathode
- E. Electrolyte fill plug (wrap with pipe tape)
- F. Pressure equalizing port
- G. Information label

3. Hold the sensor over a container with the cathode pointing down.
4. Remove the fill plug.
5. Allow the electrolyte solution to drain out.
6. Inspect the cathode.
 - a) If it is tarnished, clean it using a cotton-tipped swab dipped in baking soda or alumina.
Use type A dry powder alumina intended for metallographic polishing of medium and soft metals.
 - b) Rinse thoroughly with water.
7. Wrap the plug with two turns of pipe tape and set aside.
8. Prepare a new membrane.
 - a) Hold the membrane assembly with the cup formed by the membrane and membrane holder pointing up.
 - b) Fill the cup with electrolyte solution allowing the wood ring to soak up the electrolyte solution.
9. Hold the sensor at about a 45 degree angle with the cathode end pointing up.
10. Add electrolyte solution through the fill hole until the liquid overflows.
11. Tap the sensor near the threads to release trapped air bubbles.
12. Add more electrolyte solution if necessary.

13. Place the fill plug in the electrolyte port and begin screwing it in.
14. After several threads have engaged, rotate the sensor so that the cathode is pointing up and continue tightening the fill plug.
Do not overtighten.
15. Place a new O-ring in the groove around the cathode post.
16. Cover the holes at the base of the cathode stem with several drops of electrolyte solution.
17. Insert a small blunt probe, like a toothpick with the end cut off, through the pressure equalizing port. See [Figure 7-1](#).

NOTICE

Equipment damage

A sharp probe may puncture the bladder and destroy the sensor.

Do not use a sharp probe.

18. Place a drop of electrolyte solution on the cathode; then place the membrane assembly over the cathode.
19. Screw the membrane retainer in place.
The rebuilt sensor may take 10-15 minutes to stabilize. If the wood ring was not allowed to sufficiently soak in the electrolyte during the previous steps this step may take several hours.

Table 7-1: Spare parts

Part number	Description
33523-00	Electrolyte fill plug
9550094	O-ring, Viton® 2-014
33521-00	Membrane retainer
23501-08	Free chlorine membrane assembly: includes one membrane assembly and one O-ring
23502-08	Free chlorine membrane kit: includes three membrane assemblies and three O-rings
9210356	#4 free chlorine sensor fill solution, 4 oz (120 mL)

7.3 pH sensor

7.3.1 pH sensor maintenance

When used in clean water, the pH sensor requires little maintenance.

Generally, the sensor needs maintenance when the response becomes sluggish or noisy. In clean water, the typical cleaning frequency is once a month. In water containing large amounts of suspended solids, for example, open recirculating cooling water, cleaning frequency will be substantially greater.

7.3.2 Clean the pH sensor

Procedure

1. Remove soft deposits by rinsing with a stream of water from a wash bottle.
2. If the sensor becomes coated with rust, dissolve the rust by soaking the sensor in dilute citric acid (dissolve 0.2 oz. [5 g] of citric acid crystals in 3.4 oz. [100 ml] of water) for no longer than thirty minutes at room temperature.
3. Rinse the sensor thoroughly with water and soak in pH buffer for several hours.
4. Recalibrate the sensor in buffers before returning it to service.

7.3.3 Other maintenance

The Rosemount 3900VP-02-10 sensor supplied with the FCL-02 is disposable. It has no replaceable parts.

7.4 Constant head flow controller

7.4.1 General constant head flow controller information

After a period of time, deposits may accumulate in the constant head overflow chamber and in the tubing leading to the flow cell(s). Deposits increase the resistance to flow and cause the flow to gradually decrease. Loss of flow may ultimately have an impact on the sensor performance.

The flow controller is designed to provide about 2 gal/hr (120 ml/min) flow. Loss of flow to about 1 gal/hr (60 ml/min) causes about a 5 percent decrease in chlorine sensor output.

Loss of flow has almost no effect on pH sensor performance other than to increase the overall response time.

7.4.2 Clean the flow controller

The flow controller can be taken apart completely for cleaning.

Procedure

1. Use a strong flow of water to flush out the tubing.
Use a pipe cleaner or small bottle brush to remove more adherent deposits.
2. To prevent leaks, apply a thin layer of silicone grease (or equivalent) to the two O-rings as the base of the overflow chamber and to the O-ring sealing the central overflow tube to the base.

7.4.3 Other maintenance

Table 7-2 and Figure 7-2 show the replacement parts for the flow controller assembly used in the Rosemount FCL-01. Table 7-3 and Figure 7-3 show replacement parts for the flow controller assembly used in the FCL-02.

Figure 7-2: FCL-01 constant head flow controller assembly replacement parts

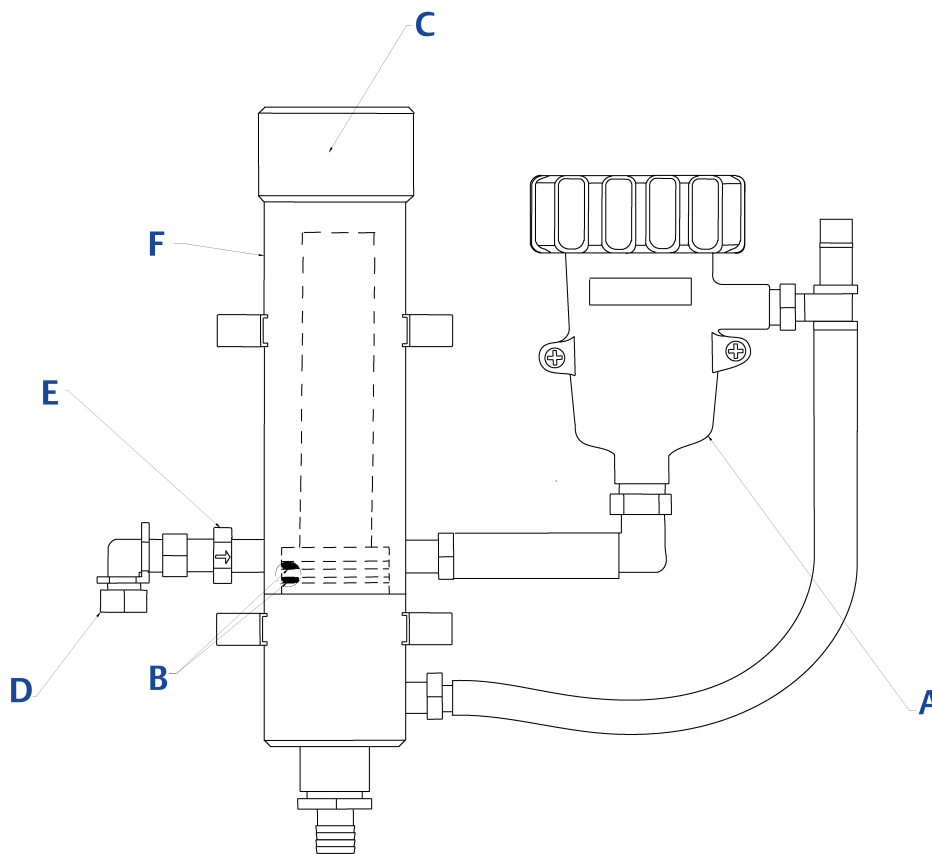

Table 7-2: FCL-01 constant head flow controller assembly replacement parts

Location in Figure 7-2	PN	Description
A	24039-00	Flow cell for chlorine sensor with bubble shedding nozzle
B	24040-00	O-ring kit, two 2-222 and one 2-024 silicone O-rings with lubricant
C	33812-00	Dust cap for constant head flow controller
D	9322032	Elbow, ¼-in. FNPT x ¼-in. OD tubing
E	9350029	Check valve, ¼-in. FNPT
F	33823-00	Outside tube for constant head device
N/A	24035-00	Flow train for FCL-01 (includes panel)

Figure 7-3: FCL-02 constant head flow controller assembly replacement parts

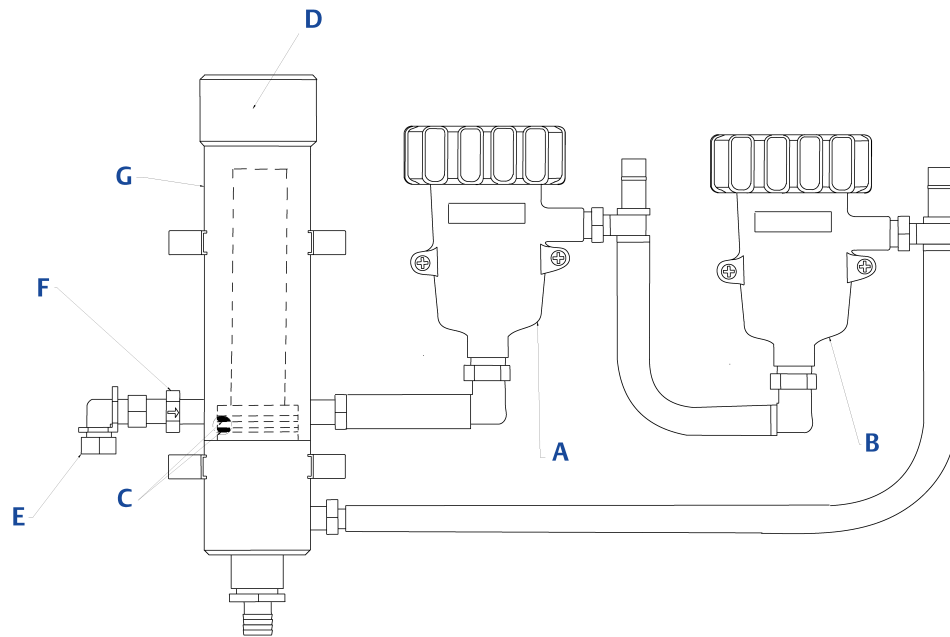

Table 7-3: FCL-02 constant head flow controller assembly replacement parts

Location in Figure 7-3	PN	Description
A	24039-00	Flow cell for chlorine sensor with bubble shedding nozzle
B	24039-01	Flow cell for pH sensor
C	24040-00	O-ring kit, two 2-222 and one 2-024 silicone O-rings with lubricant
D	33812-00	Dust cap for constant head flow controller
E	9322032	Elbow, 1/4-in. FNPT x 1/4-in. OD tubing
F	9350029	Check valve, 1/4-in. FNPT
G	33823-00	Outside tube for constant head device
N/A	24034-00	Flow Train for FCL-02 (Includes Panel)

8 Troubleshooting

8.1 Overview of troubleshooting

When the transmitter identifies a problem, the word **warning** or **fault** appears intermittently in the lower line the display. When the **fault** or **warning** message appears, press **DIAG** for more information.

See [Read and troubleshoot Fault and Warning messages](#).

Warning The instrument or sensor is usable, but you should take steps as soon as possible to correct the condition causing the warning.

Fault The measurement is seriously in error and is not to be trusted. A fault condition might also mean that the transmitter has failed. Correct fault conditions immediately. When a fault occurs, the analog output goes to 22.00 mA or to the value programmed in [Configure outputs](#).

The transmitter also displays warning messages if a calibration is seriously in error. For more information, see [Use the diagnostic feature](#).

8.2 Use the diagnostic feature

Procedure

1. To read diagnostic messages, press **DIAG**.

The screen below appears.

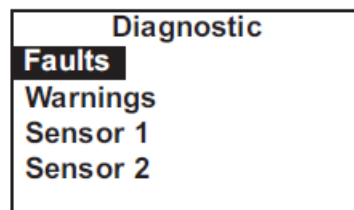

2. To display fault messages, select **Faults**. To display warning messages, select **Warnings**. To read measurement information about the sensor(s), including raw sensor signal and calibration data, choose the desired sensor and press **ENTER**. If you choose **Faults** or **Warnings**, a screen like the one below appears. **S1** means sensor 1. **S2** means sensor 2.

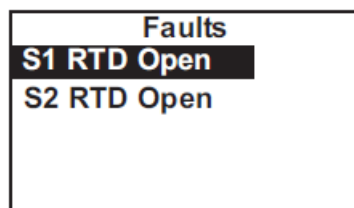

3. For additional troubleshooting information, select the desired message and press **ENTER**.
For more information, see [Troubleshooting when a Fault message is showing](#).
4. To return to the main display, press **MENU** and then **EXIT**.

8.3 Troubleshooting when a Fault message is showing

8.3.1 Main Board CPU, Main Board Factory Data, and Main Board User Data errors

These error messages mean the main board may be corrupted or the EEPROM data on the main board may be corrupted.

Recommended actions

1. Cycle the power off and then on.
2. If cycling the power does not resolve the issue, call the factory.
3. If the fault message was `Main Board User Data`, and a power cycle did not resolve the fault, reset the transmitter to factory default, re-enter user settings, and repeat calibration.

8.3.2 Hardware error

`Hardware` error means there is a missing or bad hardware component on the sensor board.

Recommended action

Replace the board.

8.3.3 Sensor Board Unknown, Sensor Board HW (Hardware) or SW (Software) Mismatch, or Sensor Board Not Communicating

These error messages mean the main board either does not recognize the sensor board or the sensor board and main board are no longer communicating.

Recommended actions

1. Verify that the ribbon cable connecting the main board (on the inside of the front panel) and the sensor board are properly seated.
2. Inspect the connecting cable for obvious tears or breaks.
3. If the ribbon cable is properly seated and appears undamaged, replace the sensor board.

8.3.4 Sensor Incompatible

This error message means the sensor board software is not supported by the main board software.

Potential cause

Either the sensor board or the main software board is too old.

The main board can only be replaced at the factory.

Recommended actions

1. Call the factory for assistance.
Emerson will ask for the main and sensor board revision numbers.
2. To read the main board revision, press **DIAG** and scroll down until `Inst SW Ver` is showing.
3. To view the sensor board revision, press **DIAG**, choose the appropriate sensor, and scroll down until `Board SW Ver` is showing.

8.3.5 Sensor CPU (central processing unit) Error

This message means the sensor board software is corrupted.

Recommended actions

1. Cycle the power off and then on.
2. If cycling the power does not help, call the factory.
This means the sensor board must be replaced.

8.3.6 Sensor RTD Open

Alert

The chlorine and pH sensors used in the Rosemount FCL contain a Pt 100 RTD for measuring temperature. `Sensor RTD Open` means the temperature measuring circuit is open.

Recommended actions

1. Confirm that the sensor RTD wires are properly connected.
2. Confirm that the Variopol connector is properly seated.
3. Disconnect the sensor from the cable and use an ohmmeter to check the resistance across the RTD.

See [Figure 8-1](#).

Figure 8-1: Pin out diagram for 498CL-01-VP Sensor (top view of connector end of sensor)

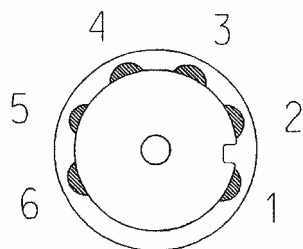

Table 8-1: Pin-out diagram

Terminal number	Description
1	Cathode
2	N/A
3	RTD sense

Table 8-1: Pin-out diagram (continued)

Terminal number	Description
4	Anode
5	RTD return
6	RTD in

At room temperature, it should be about 110 Ω.

If the resistance is very high, the RTD has failed, and the sensor must be replaced.

- If the resistance is okay, connect the Variopol cable to the sensor and disconnect the three RTD wires at the transmitter. Measure the resistance across the red and white RTD leads. Refer to [Table 8-2](#) for expected resistance readings.

Table 8-2: Resistance

Wire 1	Wire 2	Approximate resistance
Red	White	110 Ohms
Red	Red/White	110 Ohms
Red/White	White	0 Ohms

If the resistance is very high, the problem is with the VP cable, and it must be replaced.

8.3.7 Sensor 1 Not Detected

The ribbon cable from sensor 1 (chlorine) board must be plugged into the sensor 1 plug. See [Figure 2-1](#) for the location of the sensor board connectors.

Recommended actions

- Confirm that the ribbon cable connecting sensor 1 (chlorine) board to the main board is plugged into the Sensor 1 connector on the main board.
- Confirm that the ribbon cable is seated at both ends.

8.3.8 Sensor Factory Data, Sensor Board User Data, and Sensor EEPROM Write errors

These messages mean factory EEPROM data or user EEPROM data on the sensor board is corrupted or the central processing unit (CPU) on the sensor board is bad.

Recommended actions

- Cycle power off and then on.
- Replace the sensor board.

8.3.9 Sensor ADC error

There is a bad component on the sensor board.

Recommended action

Replace the sensor board.

8.3.10 Sensor RTD Out of Range

Both the chlorine and pH sensor contain a Pt 100 RTD for measuring temperature.

Alert

If the measured resistance is outside the expected range, the transmitter displays the `Out of Range` error message.

Recommended actions

1. Check wiring connections.
2. Disconnect the sensor from the cable and use an ohmmeter to check the resistance across the RTD.
The resistance should be about 110 Ω . If there is an open or short circuit, the sensor has failed and should be replaced.
3. If there is no open or short, check the transmitter.
See [Simulating temperature](#).

8.3.11 Glass Z Too High

The pH electrode is a thin glass membrane

A new Rosemount 3900VP pH sensor will have a nominal glass impedance around 50-150M Ω . While the exact value is not critical, a large increase could be due to

- A coated pH electrode. The pH sensor should be cleaned and reinstalled.
- A dry pH electrode. The pH electrode is dry and will need to be resubmerged into the process liquid.
- Aged glass electrode. The impedance of a pH sensor will increase with age. At this time the pH sensor should be considered for replacement.

8.3.12 Reference Impedance Too High

The Rosemount 3900VP pH Sensor supplied with the FCL-02 has a porous reference junction, so the normal reference impedance is low, less than 5 k Ω .

Potential cause

High reference impedance suggests that the junction is severely fouled, the fill solution has become depleted, or the junction is not fully submerged in the sample.

Recommended actions

1. Confirm that the sample is flowing to the pH flow cell.
2. Clean the reference junction.
3. Check the sensor in buffers. If the readings are accurate, and the response is reasonably rapid (< five minutes to reach a stable reading), the sensor is usable. Clear the fault by increasing the reference impedance fault limit.
See [Definitions of pH calibration](#).
4. Replace the sensor if the response in buffers is bad.

8.3.13 Broken Glass

The sensing element in the pH sensor is a thin glass membrane. Normally, the impedance of the glass membrane is about 50 - 150 MΩ. If the glass membrane gets broken or cracked, the impedance drops to less than 10 MΩ.

Recommended actions

1. Check sensor settings under the **Measurement** submenu. Confirm that the preamplifier location is set to `transmitter`.
2. Confirm that the pH sensor is installed in the flow cell and sample is flowing through the cell.
3. Check the sensor response in two buffers having different pH values.
If the membrane is cracked or broken, the pH reading will be about the same in both buffers.
4. Replace the pH sensor.

8.4 Troubleshooting when a Warning message is showing

8.4.1 Sensor No Solution Gnd

This message implies that the pH sensor is miswired.

Recommended action

Check sensor wiring.

8.4.2 Sensor Need Factory Cal

Potential cause

The sensor board was improperly calibrated at the factory

Recommended action

Call the factory for assistance.

8.4.3 Sensor Out of Range

This warning message applies to the pH sensor only. It appears when the raw signal from the pH sensor is greatly outside the range expected for a properly operating sensor.

Recommended actions

1. Confirm that the pH sensor is plugged into the Variopol (VP) cable labeled `pH sensor`.
2. Verify wiring (**Wire sensor**) and that preamplifier location is set to `transmitter`.
3. Replace the pH sensor.

8.4.4 Sensor Negative Reading

This warning message applies to the chlorine sensor only. The transmitter converts the raw sensor current to ppm chlorine by subtracting the zero current from the raw current and multiplying the result by a conversion factor. If the zero current is larger than the raw current, the result will be negative.

Recommended actions

1. Check the zero current.
It should be less than about 10 nA.
2. If it is greater than 10 nA, repeat the zero step.
If the zero current is in the correct range, the negative reading might be the result of the raw current or the sensitivity being too low. A properly operating sensor should generate between 250 and 350 nA for every 1 ppm free chlorine at pH 8.
3. Recalibrate the sensor. If necessary, clean or replace the membrane and check the fill solution.
4. Replace the sensor.

8.4.5 Sensor RTD Sense Open

The transmitter measures temperature using a three-wire RTD. See [Figure 8-5](#). The transmitter uses the in and return leads to measure the resistance of the RTD. The third lead, called the sense line, is connected to the return lead at the sensor. The sense line allows the transmitter to correct for the resistance of the in and return leads and to compensate for changes in wire resistance caused by changes in ambient temperature.

Recommended actions

1. Check wiring.
2. Disconnect the sense and return wires and check the resistance between them.
It should be less than 1 Ω . Even though the sense line is open, the sensor is still usable.
3. Use a wire jumper to connect the sense and return terminals to the sensor terminal strip.
The temperature reading will no longer be corrected for the lead resistance, nor will the transmitter be able to compensate for changes in ambient temperature. The error could be several $^{\circ}\text{C}$ or more.
4. Replace the sensor.

8.4 Sensor Temperature High or Low

Potential cause

The sensor RTD is most likely miswired.

Recommended actions

1. Check wiring connections.
- 2.
3. Replace the sensor.

8.4.6 Broken Glass Disabled

The impedance of the pH glass electrode is a strong function of temperature.

As temperature increases, the glass impedance decreases. Because the `Broken Glass` fault message appears when the glass impedance becomes too low, it is important that low impedance readings be properly connected for the temperature effects. However, there is a high temperature cutoff beyond which the correction does not work. Once the temperature exceeds this value, the `Broken Glass` fault is automatically disabled.

Note

This warning should never appear in the Rosemount FCL-02.

8.5 Troubleshooting when no error message is showing - chlorine

8.5.1 Zero current is too high

Recommended actions

1. Check that the sensor is properly wired to the transmitter.
See [Sensor wiring](#).
2. Check that the zero solution is chlorine free. Commercially available bottled water (drinking water, not distilled) provides a consistent zero solution. If the only sample available is from the process, test with a portable chlorine analyzer and ensure residual chlorine is less than 0.02 ppm.
3. Check that adequate time has been allowed for the sensor to reach a minimum stable residual current.
It may take several hours, sometimes as long as overnight, for a new sensor to stabilize.
4. Check the membrane for damage and replace if necessary.

8.5.2 Zero current is unstable

Potential cause

Readings are often erratic when a new or rebuilt sensor is first placed in service. Readings usually stabilize after about an hour.

Recommended actions

1. Check that the sensor is properly wired to the transmitter. See [Figure 2-2](#). Verify that all wiring connections are tight.
2. Make sure that the conductivity of the zero solution is greater than 50 $\mu\text{S}/\text{cm}$.

NOTICE

Do not use deionized or distilled water to zero the sensor.

If a zero solution is being prepared on site, ensure there is more than 0.5 g of sodium chloride per liter of water.

3. To ensure electrolyte flow from the sensor reservoir to the space between the cathode and membrane, hold the sensor vertically and sharply shake several times.
 - a) If shaking does not work, try clearing the holes around the cathode stem.
 - b) Unscrew the membrane retainer and remove the membrane assembly. Make sure the wood ring remains with the membrane assembly.
 - c) Apply low pressure air to the fill port to dislodge plugs in the sensor housing.
 - d) Replace the membrane.
4. Verify that the sensor is filled with electrolyte solution.

8.5.3 Sensor can be calibrated, but the current is too low

Recommended actions

1. Make sure the temperature is not too low and the pH is not too high.

Sensor current is a strong function of pH and temperature. The sensor current decreases about 3 percent for every °C drop in temperature. Sensor current also decreases as pH increases. Above pH 7, a 0.1 unit increase in pH lowers the current about 5 percent.
2. Sensor current depends on the rate of sample flow past the sensor tip. If the flow is too low, chlorine readings will be low. Verify that the chlorine sensor is installed in the correct flow cell. Be sure the liquid level in the constant head sampler is level with the central overflow tube and that excess sample is flowing down the tube. If necessary, disassemble and clean the overflow sampler. See [Constant head flow controller](#).
3. Low current can be caused by lack of electrolyte flow to the cathode. See [Step 3](#) in [Zero current is unstable](#).
4. Make sure the membrane is not fouled or coated. A dirty membrane inhibits diffusion of free chlorine through the membrane, reducing the sensor current and increasing the response time. Clean the membrane by rinsing it with a stream of water from a wash bottle.

NOTICE

Pressing on the membrane may damage the mesh cathode.

Do not use a tissue to clean the membrane.

5. If cleaning the membrane does not improve the sensor response, replace the membrane and electrolyte solution. If necessary, polish the cathode. See [Chlorine sensor](#) for details.
6. Ensure the outlet is draining to atmosphere and there is no back pressure on the FCL panel.

8.5.4 Process readings are erratic

Readings are often erratic when a new sensor or rebuilt sensor is first placed in service. The current usually stabilizes after a few hours.

Recommended actions

1. Verify that wiring is correct. Pay particular attention to shield and ground connections.
2. If automatic pH correction is being used, check the pH reading. If the pH reading is noisy, the chlorine reading will also be noisy. If the pH sensor is the cause of the noise, use manual pH correction until the problem with the pH sensor can be corrected.
Also refer to Section for troubleshooting noisy pH readings.
3. Rebuild sensor. Refill the sensor electrolyte and replace membrane. In the process of rebuilding, if the holes between the membrane and electrolyte reservoir are plugged, apply low pressure air to the fill port.

8.5.5 Readings drift

Recommended actions

1. Check to see if the sample temperature is changing.
Membrane permeability is a function of temperature. The transmitter automatically corrects for changes in sensor current caused by temperature changes. The time constant for the Rosemount 499ACL-01 sensor is about five minutes. Therefore, the reading may drift for a while after a sudden temperature change.
2. Make sure the membrane is clean.
For the sensor to work properly, chlorine must diffuse freely through the membrane. A coating on the membrane will interfere with the passage of chlorine, resulting in a slow response. Clean the membrane by rinsing with a stream of water from a wash bottle.

NOTICE

Equipment damage

Do not use a tissue to wipe the membrane.

3. Make sure the sample flow is in the recommended range.
Gradual loss of flow will cause downward drift. Be sure the liquid level in the constant head sampler is level with the central overflow tube and that excess sample is flowing down the tube. If necessary, disassemble and clean the overflow sampler. See [Constant head flow controller](#).
4. Check to see if the pH of the process is changing.
If using manual pH, a gradual change in pH will cause a gradual change in the chlorine reading.
5. Check to see if a bubble is trapped against the membrane.
For the sensor to work properly, the chlorine must continuously diffuse through the membrane. Bubbles block the chlorine in the sample from reaching the membrane, so readings drift downwards as bubbles form and grow. The nozzle at the bottom of the flow cell pushes bubbles to the edges of the membrane where they do no harm. In cold samples, the nozzle may not be as effective.
 - a) If bubbles are visible, confirm that they are blocking the membrane by removing the sensor from the flow cell and replacing it.
Removing the sensor breaks the bubbles, so when you replace the sensor, readings return to normal.

- b) Confirm that the nozzle is properly positioned in the flow cell. Line up your eye with the bottom of the membrane retainer.
No gap should be visible between the end of the nozzle and membrane retainer.
6. If the sensor is new or has been recently serviced, wait a few hours.
New or rebuilt sensors may require several hours to stabilize.

8.5.6 Sensor does not respond to changes in chlorine levels

Recommended actions

1. Make sure the grab sample test is accurate and that the grab sample is representative of the sample flowing to the sensor.
2. Make sure that sample is flowing past the sensor, that the liquid level in the constant head sampler is level with the central overflow tube, and that excess sample is flowing down the tube. If necessary, disassemble and clean the overflow sampler.
See [Constant head flow controller](#).
3. Make sure the pH compensation is correct. If using manual pH correction, verify that the pH value in the transmitter equals the actual pH within ± 0.1 pH. If using automatic pH correction, check the calibration of the pH sensor.
4. Make sure the membrane is clean. Clean the membrane with a stream of water and replace it if necessary.
 - a) Check that the holes at the base of the cathode stem are open. Use a straightened paper clip to clear blockages.
See [Step 3 in Zero current is unstable](#)
 - b) Replace the electrolyte solution.
5. Replace the sensor.

8.5.7 Chlorine readings spike following sudden changes in pH (automatic pH correction)

Changes in pH alter the relative amounts of hypochlorous acid (HOCl) and hypochlorite ion (OCl^-) in the sample.

Because the sensor responds only to HOCl, an increase in pH causes the sensor current (and the apparent chlorine level) to drop even though the actual free chlorine concentration remains constant. To correct for the pH effect, the transmitter automatically applies a correction. Generally, the pH sensor responds faster than the chlorine sensor. After a sudden pH change, the transmitter will temporarily over-compensate and gradually return to the correct value. The time constant for return to normal is about five minutes.

8.5.8 Chlorine readings are too low

Recommended actions

1. Test the sample immediately after collecting it. Avoid exposing the sample to sunlight.
Chlorine solutions are unstable.

Zeroing the sensor before the residual current has reached a stable minimum value can cause low readings. Residual current is the current the sensor generates even when no chlorine is in the sample. Because the residual current is subtracted from the measured currents, zeroing before the current is a minimum can lead to low results.

Example: The true residual current for a free chlorine sensor is 4 nA, and the sensitivity is 350 nA/ppm. Assume the measured current is 200 nA. The true concentration is $(200-4)/350$ or 0.56 ppm. If the sensor was zeroed prematurely when the current was 10 nA, the measured concentration will be $(200-10)/350$ or 0.54 ppm. The error is 3.6 percent. Now, suppose the measured current is 400 nA. The true concentration is 1.13 ppm, and the measured concentration is 1.11 ppm. The error is 1.8 percent. However, the absolute difference between the readings remains the same, 0.02 ppm.

2. Verify that the chlorine sensor is installed in the correct flow cell, that the liquid level in the constant head sampler is level with the central overflow tube, and that excess sample is flowing down the tube. If necessary, disassemble and clean the overflow sampler.

Sensor response depends on flow. If the flow is too low, readings will be low and flow sensitive. See [Figure 1-1](#) and [Figure 1-2](#). See [Constant head flow controller](#).

8.6 Troubleshooting when no error message is showing - pH

8.6.1 Calibration error during two-point calibration

Once the two-point (manual or automatic) calibration is complete, the transmitter automatically calculates the sensor slope (at 25 °).

If the slope is greater than 60 mV/pH or less than 45 mV/pH, the transmitter displays the **Calibration Error** screen and does not update the calibration.

Recommended actions

1. Make sure the buffers are accurate. Inspect the buffers for obvious signs of deterioration, such as turbidity or mold growth.
Neutral and slightly acidic buffers are highly susceptible to molds, which can change the pH of the buffer. Alkaline buffers (pH 9 and greater), if they have been exposed to air for long periods, might also be inaccurate. Alkaline buffers absorb carbon dioxide from the atmosphere, which lowers the pH. If a high pH buffer was used in the failed calibration, repeat the calibration using a fresh buffer. If a fresh buffer is not available, use a lower pH buffer. For example, use pH 4 and 7 buffer instead of pH 7 and 10 buffer.
2. Make sure adequate time was allowed for temperature equilibration. If the sensor was in a process substantially hotter or colder than the buffer, place it in a container of water at ambient temperature for at least 20 minutes before starting the calibration.
Using auto calibration helps avoid calibration errors caused by temperature drift. The transmitter will not update readings unless the drift is less than 0.02 pH over 10 seconds.
3. Make sure correct pH values were entered during manual calibration.

Using auto calibration eliminates errors caused by improperly entering data.

4. Make sure the sensor is properly wired to the transmitter.
See [Wire sensor](#).
5. Check if the sensor is dirty or coated.
See [Clean the pH sensor](#).
6. Check if the sensor is faulty. Check the glass impedance. Press **DIAG** and choose **Sensor 2**.

Glass impedance is the third item in the display. Refer to [Table 8-3](#) for an interpretation of the impedance readings.

Table 8-3: Glass impedance (Glass imp)

Reading	Interpretation
Less than 10 MΩ	Glass bulb is cracked or broken. Sensor has failed.
Between 10 and 1000 MΩ	Normal reading.
Greater than 1000 MΩ	pH sensor may be nearing the end of its service life.

Another way of checking for a faulty sensor is to replace it with a new one. If a new sensor can be calibrated, the old sensor has failed.

7. Check if the transmitter is faulty.
The best way to check for a faulty transmitter is to simulate pH inputs. See [Simulate pH input](#).

8.6.2 Calibration error during standardization

During standardization, the millivolt signal from the pH cell is increased or decreased until the pH agrees with the pH reading from a referee instrument.

A unit change in pH requires an offset of about 59 mV. The transmitter limits the offset to ±60 mV. If the standardization causes an offset greater than ±60 mV, the transmitter will display the **Offset Error** screen. The standardization will not be updated.

Recommended actions

1. Make sure the referee pH meter is working and properly calibrated. Check the response of the referee sensor in buffers.
2. Make sure the sensor is fully immersed in the process liquid.
If the sensor is not completely submerged, it may be measuring the pH of the liquid film covering the glass bulb and reference element. The pH of this film may be different from the pH of the bulk liquid.
3. Check if the sensor is fouled.
The sensor measures the pH of the liquid adjacent to the glass bulb. If the sensor is heavily fouled, the pH of liquid trapped against the bulb may be different from the bulk liquid.
4. Check if the sensor has been exposed to poisoning agents (sulfides or cyanides) or if it has been exposed to extreme temperatures.
Poisoning agents and high temperature can shift the reference voltage many hundred millivolts.

8.6.3 Sensor does not respond to known pH changes

Recommended actions

1. Check if the pH sensor is responsive to buffers.
Check sensor response in two buffers at least two pH units apart.
2. Make sure the expected pH change really occurred. Use a second meter to verify the change.
3. Make sure sample is flowing past the sensor. Be sure the liquid level in the constant head sampler is level with the central overflow tube and that excess sample is flowing down the tube. If necessary, disassemble and clean the overflow sampler.
See [Constant head flow controller](#).
4. Make sure the sensor is properly wired to the transmitter.
See [Wire sensor](#).
5. Check if the glass bulb is cracked or broken. Check the glass electrode impedance.
See [Calibration error during two-point calibration](#).
6. Make sure the transmitter is working properly. Check the transmitter by simulating the pH input.
See [Simulate pH input](#).

8.6.4 Buffer calibration is acceptable; process pH is slightly different from expected value

Differences between pH readings made with an on-line instrument and a laboratory or portable instrument are normal.

The on-line instrument is subject to process variables (for example, ground potentials, stray voltages, and orientation effects) that do not affect the laboratory or portable instrument.

Recommended action

To make the process readings agree with a referee instrument, see [Standardize pH value](#).

8.6.5 Calibration was successful, but process pH is grossly wrong and/or noisy

Grossly wrong or noisy readings suggest a ground loop (measurement system connected to earth ground at more than one point), a floating system (no earth ground), or noise being brought into the transmitter by the sensor cable.

The problem arises from the process or installation. It is not a fault of the transmitter. The problem should disappear once the sensor is taken out of the system. Check the following:

Recommended actions

1. Confirm a ground loop.
 - a) Verify that the system works properly in buffers. Be sure there is no direct electrical connection between the buffer containers and the process liquid or piping.

- b) Strip back the ends of a heavy gauge wire. Connect one end of the wire to the process piping or place it in the process liquid. Place the other end of the wire in the container of buffer with the sensor.
The wire makes an electrical connection between the process and sensor.

If offsets and noise appear after making the connection, a ground loop exists.

2. Ground the piping or tank to a local earth ground.

The measurement system needs one path to ground: through the process liquid and piping. Plastic piping, fiber glass tanks, and ungrounded or poorly grounded vessels do not provide a path. A floating system can pick up stray voltages from other electrical equipment.

If noise persists, simple grounding is not the problem. Noise is probably being carried into the instrument through the sensor wiring. Go to [Step 3](#).

3. Simplify the sensor wiring.

- a) Disconnect all sensor wires at the transmitter except: IN REFERENCE, IN pH, RTD IN, and RTD RETURN.

See the wiring diagrams in [Wire sensor](#).

- b) Tape back the ends of the disconnected wires to keep them from making accidental connections with other wires or terminals.

- c) Connect a jumper wire between the RTD RETURN and RTD SENSE terminals.

See the wiring diagrams in [Wire sensor](#).

If noise and/or offsets disappear, the interference was coming into the transmitter through one of the sensor wires. You can operate the system permanently with simplified wiring.

4. Check for extra ground connections or induced noise. To avoid induced noise in the sensor cable, run it as far away as possible from power cables, relays, and electric motors. If ground loop problems persist, consult the factory.

An experienced service technician may need to solve the problem.

8.6.6 pH readings are moderately noisy and tend to wander

Potential cause

pH readings that are moderately noisy (± 0.1 pH) and tend to wander are probably caused by bubbles getting trapped against the pH sensor.

Although the overflow sampler is designed to allow bubbles to escape before they reach the pH sensor, and the sensor itself is designed so trapped air bubbles don't interfere with the measurement, bubbles may occasionally be a problem.

Recommended actions

1. Shake the sensor to dislodge the bubbles.
2. If bubbles remain a problem, contact the factory.

8.7 Troubleshooting when no error message is showing - general

8.7.1 Difference between transmitter and standard thermometer is greater than 3 °C

Recommended actions

1. Make sure the reference thermometer, RTD, or thermistor is accurate.
General purpose liquid-in-glass thermometers, particularly ones that have been mistreated, can have surprisingly large errors.
2. Make sure the temperature element in the pH sensor is completely submerged in the test liquid.
3. Make sure the standard temperature sensor is submerged to the correct level.
4. Review [Calibrate temperature](#).

8.7.2 Current output too low

Load resistance is too high. Maximum load is 550 Ω.

8.7.3 Alarm relays don't work

Recommended action

Verify the relays are properly wired.

8.8 Simulate chlorine inputs

To check the performance of the transmitter, use a decade box and 1.5 V battery to simulate the current from the sensor. The battery, which opposes the polarizing voltage, is necessary to ensure that the sensor current has the correct sign.

Procedure

1. Disconnect the anode and cathode leads from terminals 1 and 2 on TB3 and connect a decade box and 1.5 V battery as shown in [Figure 8-2](#).

Figure 8-2: Simulating chlorine

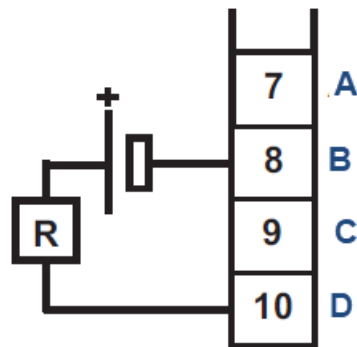

- A. Anode shield
- B. Anode
- C. Cathode shield
- D. Cathode

It is not necessary to disconnect the RTD leads.

2. Set the decade box to 2.8 M Ω .
3. Note the sensor current.

It should be about 500 nA. The actual value depends on the voltage of the battery. To view the sensor current, go to the main display and press **DIAG**. Choose `sensor`
1. The input current is the second line in the display.

4. Change the decade box resistance and verify that the correct current is shown. Calculate current from the equation:

$$\text{current (nA)} = \frac{V_{\text{battery}} - 200 \text{ (voltage in mV)}}{\text{resistance(M}\Omega\text{)}}$$

The voltage of a fresh 1.5 volt battery is about 1.6 volt (1600 mV).

8.9 Simulate pH input

To simulate a pH measurement, connect a standard millivolt source to the transmitter. If the transmitter is working properly, it will accurately measure the input voltage and convert it to pH.

Procedure

1. Set **automatic temperature correction** to `Manual` and set **manual temperature** to `25 °C`.
2. Turn off solution and temperature correction.
See [Configuring temperature related settings](#).
3. Disconnect the sensor and jumper wire between the `IN REFERENCE` and `IN pH` terminals.
4. Press **DIAG** and choose `sensor 2 (pH)`.
The **input voltage** should be `0 mV`, and the **pH** should be `7.00`. Because calibration data stored in the transmitter may be offsetting the input voltage, the displayed pH may not be exactly 7.00.
5. If a standard millivolt source is available, disconnect the jumper wire between `IN REFERENCE` and `IN pH` and connect the voltage source as shown in [Figure 8-3](#).

Figure 8-3: Simulating pH input

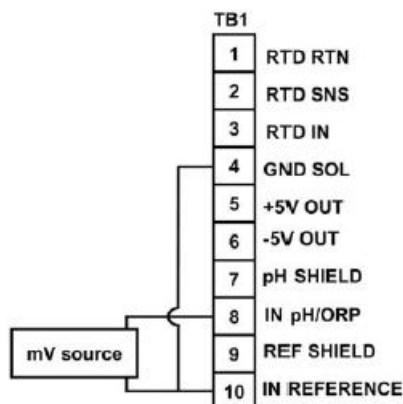

Be sure to jumper the `IN REFERENCE` and `GND SOL` terminals.

6. Calibrate the transmitter using the procedure in [Calibrate pH sensor manually](#).
Use `0.0 mV` for Buffer 1 (pH 7.00) and `-177.4 mV` for Buffer 2 (pH 10.00).
If the transmitter is working properly, it should accept the calibration. The slope should be `59.16 mV/pH`, and the offset should be zero.
7. To check linearity, return to the main display and the **pH/temperature/mV** screen. Set the voltage source to the value shown in the table and verify that the pH and millivolt readings match the values in [Table 8-4](#)

Table 8-4: Voltage and pH

Voltage (mV)	pH (at 77 °F [25 °C])
295.8	2.00
177.5	4.00

Table 8-4: Voltage and pH (continued)

Voltage (mV)	pH (at 77 °F [25 °C])
59.2	6.00
-59.2	8.00
-177.5	10.00
-295.8	12.00

8.10 Simulating temperature

8.10.1 General information about simulating temperature

The transmitter accepts a Pt100 resistance temperature device. The Pt100 RTD is a three-wire configuration.

See [Figure 8-4](#).

Figure 8-4: Three-wire RTD configuration

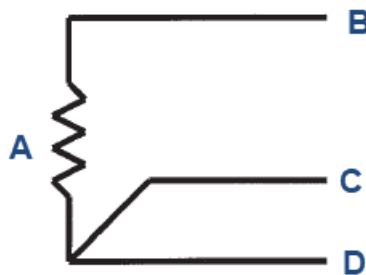

- A. RTD
- B. RTD in
- C. RTD sense
- D. RTD return

Although only two wires are required to connect the RTD to the transmitter, using a third (and sometimes fourth) wire allows the transmitter to correct for the resistance of the lead wires and for changes in the lead wire resistance with temperature.

8.10.2 Simulating temperature

To simulate the temperature input, wire a decade box to the transmitter as shown in [Figure 8-5](#).

Figure 8-5: Simulating RTD inputs

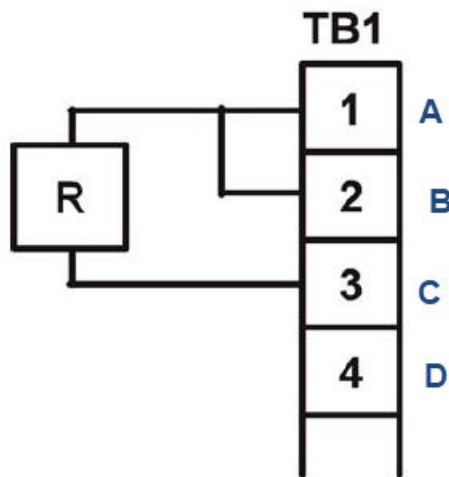

- A. RTD return
- B. RTD sense
- C. RTD in
- D. RTD shield

To check the accuracy of the temperature measurement, set the resistor simulating the RTD to the values indicated in [Table 8-5](#) and note the temperature readings. The measured temperature might not agree with the value in [Table 8-5](#). During sensor calibration, an offset might have been applied to make the measured temperature agree with a standard thermometer. The offset is also applied to the simulated resistance. The transmitter is measuring temperature correctly if the difference between measured temperatures equals the difference between the values in the table to within ± 0.1 °C.

For example, start with a simulated resistance of 103.9Ω , which corresponds to 10.0 °C. Assume the offset from the sensor calibration was -0.3Ω . Because of the offset, the transmitter calculates temperature using 103.6Ω . The result is 9.2 °C. Now change the resistance to 107.8Ω , which corresponds to 20.0 °C. The transmitter uses 107.5Ω to calculate the temperature, so the display reads 19.2 °C. Because the difference between the displayed temperatures (10.0 °C) is the same as the difference between the simulated temperatures, the transmitter is working correctly.

Table 8-5: Temperature and resistance

Temperature (°C)	Pt 100 (Ω)
0	100.0
10	103.9
20	107.8
25	109.7
30	111.7
40	115.5
50	119.4
60	123.2
70	127.1

Table 8-5: Temperature and resistance (*continued*)

Temperature (°C)	Pt 100 (Ω)
80	130.9
85	132.8
90	134.7
100	138.5

For more information: [Emerson.com/global](https://emerson.com/global)

©2023 Emerson. All rights reserved.

Emerson Terms and Conditions of Sale are available upon request. The Emerson logo is a trademark and service mark of Emerson Electric Co. Rosemount is a mark of one of the Emerson family of companies. All other marks are the property of their respective owners.

ROSEMOUNT™

