

Micro Motion™ 5700 with Ethernet Transmitters

Configuration and Use Manual



Safety messages

Safety messages are provided throughout this manual to protect personnel and equipment. Read each safety message carefully before proceeding to the next step.

Safety and approval information

This Micro Motion product complies with all applicable European directives when properly installed in accordance with the instructions in this manual. Refer to the EU declaration of conformity for directives that apply to this product. The following are available: the EU declaration of conformity, with all applicable European directives, and the complete ATEX Installation Drawings and Instructions. In addition the IECEx Installation Instructions for installations outside of the European Union and the CSA Installation Instructions for installations in North America are available on the internet at www.emerson.com or through your local Micro Motion support center.

Information affixed to equipment that complies with the Pressure Equipment Directive, can be found on the internet at www.emerson.com. For hazardous installations in Europe, refer to standard EN 60079-14 if national standards do not apply.

Other information

Full product specifications can be found in the product data sheet. Troubleshooting information can be found in the configuration manual. Product data sheets and manuals are available from the Micro Motion web site at www.emerson.com.

Return policy

Follow Micro Motion procedures when returning equipment. These procedures ensure legal compliance with government transportation agencies and help provide a safe working environment for Micro Motion employees. Micro Motion will not accept your returned equipment if you fail to follow Micro Motion procedures.

Return procedures and forms are available on our web support site at www.emerson.com, or by phoning the Micro Motion Customer Service department.

Emerson Flow customer service

Email:

- Worldwide: flow.support@emerson.com
- Asia-Pacific: APflow.support@emerson.com

Telephone:

North and South America		Europe and Middle East		Asia Pacific	
United States	800-522-6277	U.K. and Ireland	0870 240 1978	Australia	800 158 727
Canada	+1 303-527-5200	The Netherlands	+31 (0) 70 413 6666	New Zealand	099 128 804
Mexico	+52 55 5809 5010	France	+33 (0) 800 917 901	India	800 440 1468
Argentina	+54 11 4809 2700	Germany	0800 182 5347	Pakistan	888 550 2682
Brazil	+55 15 3413 8000	Italy	+39 8008 77334	China	+86 21 2892 9000
Chile	+56 2 2928 4800	Central & Eastern	+41 (0) 41 7686 111	Japan	+81 3 5769 6803
Peru	+51 15190130	Russia/CIS	+7 495 995 9559	South Korea	+82 2 3438 4600
		Egypt	0800 000 0015	Singapore	+65 6 777 8211
		Oman	800 70101	Thailand	001 800 441 6426
		Qatar	431 0044	Malaysia	800 814 008
		Kuwait	663 299 01		
		South Africa	800 991 390		
		Saudi Arabia	800 844 9564		
		UAE	800 0444 0684		

Contents

Chapter 1	Before you begin.....	7
	1.1 About this manual.....	7
	1.2 Hazard messages.....	7
	1.3 Related documents.....	8
	1.4 Communication methods.....	8
Chapter 2	Quick start.....	9
	2.1 Power up the transmitter.....	9
	2.2 Check meter status.....	9
	2.3 Commissioning wizards.....	10
	2.4 Make a startup connection to the transmitter.....	10
	2.5 Set the transmitter clock.....	11
	2.6 View the licensed features.....	11
	2.7 Set informational parameters.....	12
	2.8 Characterize the meter (if required).....	12
	2.9 Verify mass flow measurement.....	15
	2.10 Verify the zero.....	15
Chapter 3	Introduction to configuration and commissioning.....	17
	3.1 Security and write protection.....	17
	3.2 Work with configuration files.....	22
Chapter 4	Configure process measurement.....	29
	4.1 Configure Sensor Flow Direction Arrow	29
	4.2 Configure mass flow measurement.....	30
	4.3 Configure volume flow measurement for liquid applications.....	35
	4.4 Configure Gas Standard Volume (GSV) flow measurement.....	39
	4.5 Configure density measurement.....	44
	4.6 Configure temperature measurement.....	46
	4.7 Configure Pressure Measurement Unit	48
	4.8 Configure Velocity Measurement Unit	49
Chapter 5	Configure process measurement applications.....	51
	5.1 Set up the API Referral application	51
	5.2 Set up concentration measurement.....	61
	5.3 Configure the batching application.....	77
Chapter 6	Configure advanced options for process measurement.....	83
	6.1 Configure Response Time	83
	6.2 Detect and report two-phase flow.....	83
	6.3 Configure Flow Rate Switch	85

	6.4 Configure events.....	86
	6.5 Configure totalizers and inventories.....	88
	6.6 Configure logging for totalizers and inventories.....	91
	6.7 Configure Process Variable Fault Action	92
Chapter 7	Configure device options and preferences.....	97
	7.1 Configure the transmitter display.....	97
	7.2 Configure the transmitter's response to alerts.....	103
	7.3 Control button sensitivity on the display.....	111
Chapter 8	Integrate the meter with the control system.....	113
	8.1 Channel configuration.....	113
	8.2 Configure Ethernet Channel A and Channel B.....	113
	8.3 Configure I/O Channel C.....	113
	8.4 Configure an mA Output.....	114
	8.5 Configure a Frequency Output.....	122
	8.6 Configure a Discrete Output.....	127
	8.7 Configure a Discrete Input.....	130
Chapter 9	Set the Ethernet protocol.....	133
Chapter 10	Configure, setup, and use a printer for tickets.....	135
	10.1 TM-T88VI printer limitations.....	135
	10.2 Set up the printer.....	135
	10.3 Reset the interface settings.....	138
	10.4 Configure the printer and print tickets.....	139
	10.5 Configure a Discrete Input or discrete event.....	140
	10.6 Ticket types.....	140
Chapter 11	Complete the configuration.....	145
	11.1 Test or tune the system using sensor simulation.....	145
	11.2 Enable or disable software write-protection.....	146
Chapter 12	Transmitter operation.....	149
	12.1 View process and diagnostic variables.....	149
	12.2 View and acknowledge status alerts.....	150
	12.3 Read totalizer and inventory values.....	151
	12.4 Start, stop, and reset totalizers and inventories.....	152
Chapter 13	Operation using the batcher.....	155
	13.1 Run a batch.....	155
	13.2 Perform AOC calibration.....	158
Chapter 14	Measurement support.....	161
	14.1 Use Smart Meter Verification.....	161
	14.2 Advanced Phase Measurement.....	168
	14.3 Piecewise linearization (PWL) for calibrating gas meters.....	169

	14.4 Zero the meter.....	169
	14.5 Set up pressure compensation.....	172
	14.6 Validate the meter.....	175
	14.7 Perform a (standard) D1 and D2 density calibration.....	177
	14.8 Adjust concentration measurement with Trim Offset	180
	14.9 Adjust concentration measurement with Trim Slope and Trim Offset	180
Chapter 15	Maintenance.....	183
	15.1 Install a new transmitter license.....	183
	15.2 Upgrade the transmitter firmware.....	184
	15.3 Reboot the transmitter.....	185
	15.4 Battery replacement.....	186
Chapter 16	Log files, history files, and service files.....	187
	16.1 Generate history files.....	187
	16.2 Generate service files.....	193
Chapter 17	Troubleshooting.....	199
	17.1 Status LED and device status.....	199
	17.2 Network status LED.....	199
	17.3 API Referral troubleshooting.....	200
	17.4 Batch troubleshooting.....	200
	17.5 Concentration measurement troubleshooting.....	202
	17.6 Alert when connecting a core processor to a remote 5700 transmitter.....	203
	17.7 Density measurement troubleshooting.....	204
	17.8 Discrete Input troubleshooting.....	206
	17.9 Discrete Output troubleshooting.....	206
	17.10 Flow measurement troubleshooting.....	207
	17.11 Frequency Output troubleshooting.....	210
	17.12 mA Output troubleshooting.....	212
	17.13 Status alerts, causes, and recommendations.....	215
	17.14 Perform a core processor resistance test.....	234
	17.15 Check the cutoffs.....	236
	17.16 Check the direction parameters.....	236
	17.17 Check the drive gain.....	236
	17.18 Check for internal electrical problems.....	237
	17.19 Check Frequency Output Fault Action	238
	17.20 Check the scaling of the Frequency Output.....	238
	17.21 Check grounding.....	238
	17.22 Perform loop tests.....	238
	17.23 Check Lower Range Value and Upper Range Value	244
	17.24 Check mA Output Fault Action	245
	17.25 Trim mA Output.....	245

	17.26 Check the pickoff voltage.....	246
	17.27 Check power supply wiring.....	246
	17.28 Check for radio frequency interference (RFI).....	247
	17.29 Check sensor-to-transmitter wiring.....	248
	17.30 Using sensor simulation for troubleshooting.....	248
	17.31 Check the printing.....	249
	17.32 Check for two-phase flow (slug flow).....	249
	17.33 Check the sensor coils.....	249
Appendix A	Using the transmitter display.....	253
	A.1 Components of the transmitter display.....	253
	A.2 Access and use the display menus.....	255
Appendix B	Using ProLink III with the transmitter.....	259
	B.1 Basic information about ProLink III	259
	B.2 Connect with ProLink III	260
Appendix C	Using a web browser to configure the transmitter.....	263
	C.1 Recommended web browsers.....	263
	C.2 Configuring transmitter and PC Ethernet settings.....	263
	C.3 Log in with a web browser using a secure connection.....	264
	C.4 Log in with a web browser using an unsecure connection.....	266
	C.5 Change Ethernet login passwords.....	267
	C.6 Import the SSL Certificate into Microsoft® Windows®	268
	C.7 Private key file.....	269
	C.8 Import from a Certificate Authority.....	269
Appendix D	Concentration measurement matrices, derived variables, and process variables....	271
	D.1 Standard matrices for the concentration measurement application.....	271
	D.2 Derived variables and calculated process variables.....	272
Appendix E	Environmental compliance.....	275
	E.1 RoHS and WEEE.....	275
Appendix F	Example tickets.....	276
	F.1 Print examples.....	276

1 Before you begin

1.1 About this manual

This manual helps you configure, commission, use, maintain, and troubleshoot Micro Motion 5700 transmitters with Ethernet.

Important

This manual assumes that:

- The transmitter has been installed correctly and completely according to the instructions in the transmitter installation manual
 - Users understand basic transmitter and sensor installation, configuration, and maintenance concepts and procedures
-

1.2 Hazard messages

This document uses the following criteria for hazard messages based on ANSI standards Z535.6-2011 (R2017).

DANGER

Serious injury or death will occur if a hazardous situation is not avoided.

WARNING

Serious injury or death could occur if a hazardous situation is not avoided.

CAUTION

Minor or moderate injury will or could occur if a hazardous situation is not avoided.

NOTICE

Data loss, property damage, hardware damage, or software damage can occur if a situation is not avoided. There is no credible risk of physical injury.

Physical access

NOTICE

Unauthorized personnel can potentially cause significant damage and/or misconfiguration of end users' equipment. Protect against all intentional or unintentional unauthorized use.

Physical security is an important part of any security program and fundamental to protecting your system. Restrict physical access to protect users' assets. This is true for all systems used within the facility.

1.3 Related documents

You can find all product documentation on the product documentation DVD shipped with the product or at www.emerson.com.

See any of the following documents for more information:

- *Micro Motion 5700 Product Data Sheet*
- *Micro Motion 5700 with Ethernet Transmitters: Installation Manual*
- *Micro Motion Ethernet PROFINET Siemens Integration Guide*
- *Micro Motion 5700 Transmitters Ethernet Rockwell RSLogix Integration Guide*
- *Replacing the Junction Box for the 4200 Transmitter and the 5700 Transmitter*
- *Replacing the Sensor Cable for the 4200 Transmitter and the 5700 Transmitter*
- Sensor installation manual

1.4 Communication methods

You can use several different communications methods to interface with the transmitter. You may use different methods in different locations or for different tasks.

Interface	Tool
Display	Infrared-sensitive buttons
Universal Service Port	ProLink™ III
Ethernet ports	Web browser (http)
	<ul style="list-style-type: none">• EtherNet/IP• Modbus® TCP• PROFINET

For information about how to use the communication tools, see the appendices in this manual.

2 Quick start

2.1 Power up the transmitter

The transmitter must be powered up for all configuration and commissioning tasks, or for process measurement.

Procedure

1. Follow appropriate procedures to ensure that a new device on the network does not interfere with existing measurement and control loops.
2. Verify that the cables are connected to the transmitter as described in the installation manual.
3. Verify that all transmitter and sensor covers and seals are closed.

 **WARNING**

To prevent ignition of flammable or combustible atmospheres, ensure that all covers and seals are tightly closed. For hazardous area installations, applying power while housing covers are removed or loose can cause an explosion resulting in injury or death.

4. Turn on the electrical power at the power supply.

Postrequisites

Although the sensor is ready to receive process fluid shortly after power-up, the electronics can take up to 10 minutes to reach thermal equilibrium. Therefore, if this is the initial startup, or if power has been off long enough to allow components to reach ambient temperature, allow the electronics to warm up for approximately 10 minutes before relying on process measurements. During this warm-up period, you may observe minor measurement instability or inaccuracy.

2.2 Check meter status

Check the meter for any error conditions that require user action or that affect measurement accuracy.

Procedure

1. Wait approximately 10 seconds for the power-up sequence to complete.
Immediately after power-up, the transmitter runs through diagnostic routines and checks for error conditions. During the power-up sequence, the `Transmitter Initializing` alert is active. This alert should clear automatically when the power-up sequence is complete.
2. Check the status LED on the transmitter.

Table 2-1: Status LED and device status

Status LED condition	Device status
Solid green	No alerts are active.
Solid yellow	One or more alerts are active with Alert Severity = Out of Specification, Maintenance Required, or Function Check.

Table 2-1: Status LED and device status (continued)

Status LED condition	Device status
Solid red	One or more alerts are active with Alert Severity = Failure.
Flashing yellow (1 Hz)	The <code>Function Check in Progress</code> alert is active.

Table 2-2: Network status LED and Ethernet network connection status

Network status LED condition	Network status
Flashing green	No connections made with primary protocol host.
Solid green	Connection made with primary protocol host.
Flashing red	Connection from primary protocol host has timed out.
Solid red	Address Conflict Detection (ACD) algorithm has detected a duplicate IP address.

2.3 Commissioning wizards

The transmitter menu includes a *Guided Setup* to help you move quickly through the most common configuration parameters. ProLink III also provides a commissioning wizard.

By default, when the transmitter starts up, the Guided Setup menu is offered. You can choose to use it or not. You can also choose whether or not Guided Setup is displayed automatically.

- To enter Guided Setup upon transmitter startup, choose **Yes** at the prompt.
- To enter Guided Setup after transmitter startup, choose **Menu** → **Startup Tasks**.
- To control the automatic display of Guided Setup, choose **Menu** → **Configuration** → **Guided Setup**.

For information on the ProLink III commissioning wizard, see the *Micro Motion ProLink III with ProcessViz Software User Manual*.

As the commissioning wizards are self guided, they are not documented in detail.

2.4 Make a startup connection to the transmitter

For all configuration tools except the display, you must have an active connection to the transmitter to configure the transmitter.

Procedure

Identify the connection type to use, and follow the instructions for that connection type in the appropriate appendix.

Communications tool	Connection type to use	Instructions
ProLink III	Service port	Using ProLink III with the transmitter
Web browser	Ethernet	Using a web browser to configure the transmitter

2.5 Set the transmitter clock

Display	Menu → Configuration → Time/Date/Tag
ProLink III	Device Tools → Configuration → Transmitter Clock
Web browser	Configuration → Time/Date/Tag

The transmitter clock provides timestamp data for alerts, service logs, history logs, and all other timers and dates in the system. You can set the clock for your local time or for any standard time you want to use.

Tip

You may find it convenient to set all of your transmitter clocks to the same time, even if the transmitters are in different time zones.

Procedure

1. Select the time zone that you want to use.
2. If you need a custom time zone, select **Special Time Zone** and enter your time zone as a difference from UTC (Coordinated Universal Time).
3. Set the time appropriately for the selected time zone.

Tip

The transmitter does not adjust for Daylight Savings Time. If you observe Daylight Savings Time, you must reset the transmitter clock manually.

4. Set the month, day, and year.
The transmitter tracks the year and automatically adds a day for leap years.

2.6 View the licensed features

Display	Menu → About → Licenses → Licensed Features
ProLink III	Device Tools → Device Information → Licensed Features
Web browser	Configuration → Device Information → Licensed Features

The transmitter license controls the features (applications) that are enabled on the transmitter. You can view the licensed features to ensure that the transmitter was ordered with the required features.

Licensed features are purchased and available for permanent use. The options model code represents the licensed features.

A trial license allows you to explore features before purchasing. The trial license enables the specified features for a limited number of days. This number is displayed for reference. At the end of this period, the feature will no longer be available.

To purchase additional features or request a trial license, document the Unique ID Number and current license key from your transmitter and contact customer service. To enable the additional features or trial license, you will need to install the new license on the transmitter.

2.7 Set informational parameters

Display	Menu → Configuration → Device Information
ProLink III	Device Tools → Configuration → Informational Parameters
Web browser	Configuration → Time/Date/Tag

You can set several parameters that identify or describe the transmitter and sensor. These parameters are not used in processing and are not required.

Procedure

1. Set informational parameters for the transmitter.
 - a) Set **Transmitter Serial Number** to the serial number of your transmitter.
The transmitter serial number is provided on the metal tag that is attached to the transmitter housing.
 - b) Set **Descriptor** to any desired description of this transmitter or measurement point.
 - c) Set **Message** to any desired message.
 - d) Verify that **Model Code (Base)** is set to the base model code of the transmitter.
The base model code completely describes your transmitter, except for the features that can be licensed independently. The base model code is set at the factory.
 - e) Set **Model Code (Options)** to the options model code of the transmitter.
The options model code describes the independent features that have been licensed for this transmitter. The original options model code is set at the factory. If you license additional options for this transmitter, Micro Motion will supply an updated options model code.
2. Set informational parameters for the sensor.
 - a) Set **Sensor Serial Number** to the serial number of the sensor connected to this transmitter.
The sensor serial number is provided on the metal tag that is attached to the sensor case.
 - b) Set **Sensor Material** to the material used for the sensor.
 - c) Set **Sensor Liner** to the material used for the sensor liner, if any.
 - d) Set **Flange Type** to the type of flange that was used to install the sensor.

Do not set **Sensor Type**. **Sensor Type** is set or derived during characterization.

2.8 Characterize the meter (if required)

Display	Menu → Configuration → Sensor Parameters
ProLink III	Device Tools → Calibration Data
Web browser	Configuration → Sensor Parameters

Characterizing the meter adjusts your transmitter to match the unique traits of the sensor it is paired with. The characterization parameters (also called calibration parameters) describe the sensor’s sensitivity to flow, density, and temperature. Depending on your sensor type, different parameters are required.

Values for your sensor are provided on the sensor tag or the calibration certificate.

- If your transmitter was ordered with a sensor, it was characterized at the factory. However, you should still verify the characterization parameters.
- Perform a characterization whenever you replace a core processor.

Procedure

1. Optional: Specify **Sensor Type**.
 - Straight Tube (T-Series sensors)
 - Curved Tube (all sensors except T-Series)

Note

Unlike earlier transmitters, the 5700 derives **Sensor Type** from the user-specified values for FCF and K1 in combination with an internal ID.

2. Set the flow calibration factor: **FCF** (also called **Flow Cal** or **Flow Calibration Factor**). Be sure to include all decimal points.
3. Set the density characterization parameters: **D1**, **D2**, **TC**, **K1**, **K2**, and **FD**. (**TC** is sometimes shown as **DT**.)
4. Apply the changes as required by the tool you are using.

The transmitter identifies your sensor type, and characterization parameters are adjusted as required:

- If **Sensor Type** changed from Curved Tube to Straight Tube, five characterization parameters are added to the list.
- If **Sensor Type** changed from Straight Tube to Curved Tube, five characterization parameters are removed from the list.
- If **Sensor Type** did not change, the list of characterization parameters does not change.

5. T-Series sensors only: Set the additional characterization parameters listed below.

Characterization parameter type	Parameters
Flow	FTG, FFQ
Density	DTG, DFQ1, DFQ2

2.8.1 Sample sensor tags

Figure 2-1: Tag on newer curved-tube sensors (all sensors except T-Series)

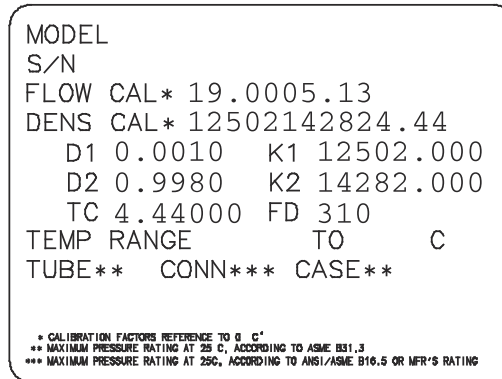

2.8.2 Flow calibration parameters (FCF, FT)

Two separate values are used to describe flow calibration: a 6-character FCF value and a 4-character FT value. They are provided on the sensor tag.

Both values contain decimal points. During characterization, these are entered as a single 10-character string. The 10-character string is called either **Flowcal** or **FCF**.

If your sensor tag shows the **FCF** and the **FT** values separately and you need to enter a single value, concatenate the two values to form the single parameter value, retaining both decimal points.

Concatenating FCF and FT

```
FCF = x.xxxx FT = y.yy Flow calibration parameter: x.xxxxxy.yy
```

2.8.3 Density calibration parameters (D1, D2, K1, K2, FD, DT, TC)

Density calibration parameters are typically on the sensor tag and the calibration certificate.

If your sensor tag does not show a D1 or D2 value:

- For **D1**, enter the Dens A or **D1** value from the calibration certificate. This value is the line-condition density of the low-density calibration fluid. Micro Motion uses air. If you cannot find a Dens A or **D1** value, enter 0.001 g/cm^3 .
- For **D2**, enter the Dens B or **D2** value from the calibration certificate. This value is the line-condition density of the high-density calibration fluid. Micro Motion uses water. If you cannot find a Dens B or **D2** value, enter 0.998 g/cm^3 .

If your sensor tag does not show a K1 or K2 value:

- For **K1**, enter the first five digits of the density calibration factor. In this sample tag, this value is shown as 12500.
- For **K2**, enter the second five digits of the density calibration factor. In this sample tag, this value is shown as 14286.

Figure 2-2: K1, K2, and TC values in the density calibration factor

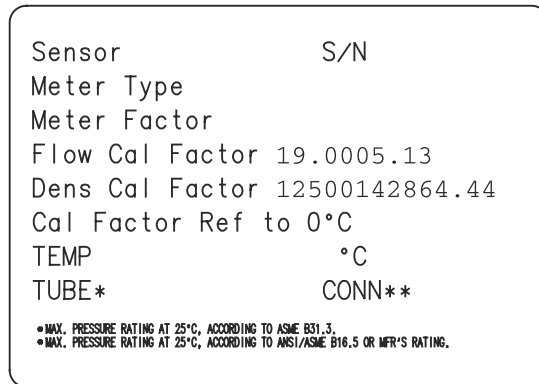

If your sensor does not show an **FD** value, contact customer service.

If your sensor tag does not show a **DT** or **TC** value, enter the last four characters of the density calibration factor. In the sample tag shown above, the value is shown as 4.44.

Do not confuse the **Meter Factor** line on the pictured sensor tag with any meter factor settings discussed in this manual.

2.9 Verify mass flow measurement

Check to see that the mass flow rate reported by the transmitter is accurate. You can use any available method.

Procedure

- Read the value for **Mass Flow Rate** on the transmitter display.
- Connect to the transmitter with ProLink III and read the value for **Mass Flow Rate** in the *Process Variables* panel.

Postrequisites

If the reported mass flow rate is not accurate:

- Check the characterization parameters.
- Review the troubleshooting suggestions for flow measurement issues.

2.10 Verify the zero

Display	Menu → Service Tools → Verification & Calibration → Meter Zero → Zero Verification
ProLink III	Device Tools → Calibration → Smart Zero Verification and Calibration → Verify Zero
Web browser	Service Tools → Verification and Calibration → Meter Zero → Zero Verification

Verifying the zero helps you determine if the stored zero value is appropriate to your installation, or if a field zero can improve measurement accuracy.

Important

In most cases, the factory zero is more accurate than the field zero. Do not zero the meter unless one of the following is true:

- The zero is required by site procedures.
- The stored zero value fails the zero verification procedure.

Do not verify the zero or zero the meter if a high-severity alert is active. Correct the problem, then verify the zero or zero the meter. You may verify the zero or zero the meter if a low-severity alert is active.

Procedure

1. Prepare the meter:
 - a) Allow the meter to warm up for at least 20 minutes after applying power.
 - b) Run the process fluid through the sensor until the sensor temperature reaches the normal process operating temperature.
 - c) Stop flow through the sensor by shutting the downstream valve, and then the upstream valve if available.
 - d) Verify that the sensor is blocked in, that flow has stopped, and that the sensor is completely full of process fluid.
2. Start the zero verification procedure, and wait until it completes.
3. If the zero verification procedure fails:
 - a) Confirm that the sensor is completely blocked in, that flow has stopped, and that the sensor is completely full of process fluid.
 - b) Verify that the process fluid is not flashing or condensing, and that it does not contain particles that can settle out.
 - c) Repeat the zero verification procedure.
 - d) If it fails again, zero the meter.

Postrequisites

Restore normal flow through the sensor by opening the valves.

Related information

[Zero the meter](#)

3 Introduction to configuration and commissioning

3.1 Security and write protection

The transmitter has several features that can help to protect it against intentional or unintentional access and configuration changes.

- When locked, the mechanical lock switch on the front of the display prevents any configuration changes to the transmitter from any local or remote configuration tool. A transmitter without a display does not have a lock switch.
- When enabled, the software setting **Write Protection** prevents any configuration changes. The setting can only be enabled if the transmitter does not have a display.
- If the Universal Service Port (USP) is disabled, the port cannot be used by any service tool to communicate with or make changes to the transmitter.
- When enabled, **Security** prevents any configuration changes being made from the display unless the appropriate password is entered.

3.1.1 Web server security

You can configure this transmitter using web services. There are multiple levels of security built into the transmitter that you can configure according to your needs and security standards, including:

- Disabling the web servers⁽¹⁾
- Disallowing firmware upgrades through the Ethernet interface
- Allowing downloads of configuration and historian files, but disallowing file uploads to the transmitter through the Ethernet interface
- Configuring Transport Layer Security (TLS) on the web server to encrypt all data transmitted between the web server and the transmitter⁽¹⁾
- Requiring user authentication and strong passwords to access the web server and the transmitter
- Notifying users through alerts if the default password has not been changed⁽¹⁾
- Disallowing configuration changes from all interfaces including the Ethernet port using transmitter security switches, such as the lock switch or write protection

This transmitter:

- Was designed to be implemented in an industrial automation control system (Level 1 and Level 2 of the Purdue Reference Architecture Model), with defense in depth security controls
- Is not intended to be directly connected to an enterprise or to an internet-facing network without a compensating control in place

⁽¹⁾ Version 2.0 and higher

3.1.2 Universal Service Port security

This transmitter is equipped with a Universal Service Port that works with USB type A connections, including compatible flash drives. There are multiple levels of security built into the transmitter's service port that you can configure according to your needs and security standards.

The service port offers the following features that enhance interface security:

- The service port is inaccessible without physical access to the transmitter and requires removal of the terminal cover
- The service port can be disabled from the transmitter through software
- The transmitter has a non-traditional operating system that is not designed to execute programs or run scripts
- The display can be password protected to limit access to the USB file menu
- Overall transmitter security switches such as the lock switch or write-protection disallows configuration changes from all interfaces including the Universal Service Port

This transmitter:

- Was designed to be implemented in an industrial automation control system (Level 1 and Level 2 of the Purdue Reference Architecture Model), with defense in depth security controls
- Is not intended to be directly connected to an enterprise or to an internet-facing network without a compensating control in place

3.1.3 Lock or unlock the transmitter

If the transmitter has a display, a mechanical switch on the display can be used to lock or unlock the transmitter. When locked, no configuration changes can be made using any configuration tool.

Figure 3-1: Lock switch on transmitter display

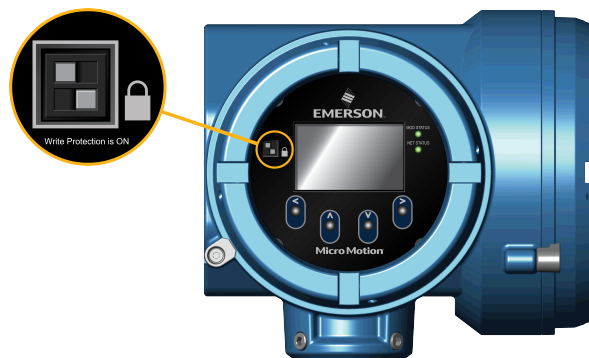

You can determine whether you need to lock or unlock the transmitter by looking at the switch.

- If the switch is in the right position, the transmitter is locked.
- If the switch is in the left position, the transmitter is unlocked.

Note

The top switch is reserved for future use.

Procedure

1. **⚠ WARNING**
If the transmitter is in a hazardous area, do not remove the housing cover while the transmitter is powered up. Failure to follow these instructions can cause an explosion resulting in injury or death.

If you are in a hazardous area, power down the transmitter.
2. Remove the transmitter housing cover.

Figure 3-2: Removing the transmitter housing cover

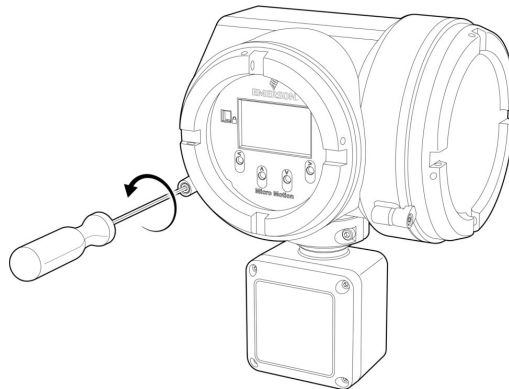

3. Using a fine-pointed tool, move the switch to the desired position.
4. Replace the transmitter housing cover.
5. If necessary, power up the transmitter.

3.1.4 Enable or disable the service port

Display	Menu → Configuration → Security → Service Port
ProLink III	Not available
Web browser	Not available

The service port is enabled by default, so you can use it for transferring files or connect to it with ProLink III. If you want to completely prevent it from being used, you can disable it.

Note

Enabling or disabling the service port will not take effect until power has been cycled to the transmitter.

⚠ WARNING

Do not use the service port if the transmitter is in a hazardous area because using the service port means that you must open the transmitter wiring compartment. Opening the wiring compartment in a hazardous area while the transmitter is powered up can cause an explosion resulting in injury or death.

3.1.5 Enable or disable software write-protection

Display	Use the mechanical switch on the display.
ProLink III	Device Tools → Configuration → Write-Protection
Web browser	Configuration → Security → Write Protection

When enabled, **Write-Protection** prevents changes to the transmitter configuration. You can perform all other functions, and you can view the transmitter configuration parameters.

Note

The write protection setting via software methods (such as ProLink III) is available only on transmitters without a display.

For transmitters with a display, write protection is available only using the lock switch on the display. See [Lock or unlock the transmitter](#).

Write-protecting the transmitter primarily prevents accidental changes to configuration, not intentional changes. Any user who can make changes to the configuration can disable write protection.

3.1.6 Configure security for the display

Display	Menu → Configuration → Security → Display Security
ProLink III	Device Tools → Configuration → Transmitter Display → Display Security
Web browser	Not available

When using the display, you can require users to enter a password to do any of the following tasks:

- Enter the main menu
- Change a parameter
- Access alert data through the display
- Start, stop, or reset totalizers or inventories via the context menu

The display password can be the same or different from the totalizer/inventory context menu control password. If different, the display password is used to reset, start, and stop totalizers or inventories using **Menu → Operations → Totalizers**.

Procedure

1. Configure **Password Required** as desired.

Option	Description
At Write	When an user chooses an action that leads to a configuration change, they are prompted to enter the display password.
Enter Menu	When the menu is selected from the process variable screen, the display password will be immediately required if Password Required is set.
Never (default)	When a user chooses an action that leads to a configuration change, they are prompted to activate $\Rightarrow \uparrow \downarrow \Leftarrow$. This is designed to protect against accidental changes to configuration. It is not a security measure.

2. If the At Write or Enter Menu option was selected, enable or disable alert security as desired.

Option	Description
Enabled	If an alert is active, the alert symbol ⓘ is shown in the upper right corner of the display but the alert banner is not displayed. If the operator attempts to enter the alert menu, they are prompted to enter the display password.
Disabled	If an alert is active, the alert symbol ⓘ is shown in the upper right corner of the display and the alert banner is displayed automatically. No password or confirmation is required to enter the alert menu.

Restriction

You cannot set **Password Required** to Never and enable alert security.

- If you did not enable **Password Required**, alert security is disabled and cannot be enabled.
- Alert security is disabled automatically if you set **Password Required** to Never after:
 - **Password Required** is initially set to either At Write or Enter Menu
 - Alert security is enabled

3. If **Password Required** has been set to At Write or Enter Menu, you will be prompted to enter the desired password.
 - Default: AAAA
 - Range: Any four alphanumeric characters
 - **Password Required** must be set to At Write or Enter Menu to enable the totalizer/inventory control context menu password option.

Important

If you enable **Password Required** but you do not change the display password, the transmitter will post a configuration alert.

4. Configure **Main Menu Available** as desired.

Option	Description
Enabled	The local display Menu option from the process variable screen will be accessible.
Disabled	The local display Menu option from the process variable screen will not be accessible.

Important

Once **Main Menu Available** has been disabled, you cannot enable it from the local display. Use another configuration tool, such as ProLink III, to re-enable main menu access from the local display.

3.2 Work with configuration files

You can save the current transmitter configuration in two forms: a backup file and a replication file. You can save the configuration to the SD card on your transmitter or to a USB drive.

Tip

You can use a saved configuration file to change the nature of the transmitter quickly. This might be convenient if the transmitter is used for different applications or different process fluids.

You can load a configuration file to the transmitter's working memory or to the transmitter's SD card. You can load either a backup file or a replication file.

- | | |
|--------------------------|--|
| Backup files | Contain all parameters. They are used to restore the current device if required. The <code>.spare</code> extension is used to identify backup files. |
| Replication files | Contain all parameters except the device-specific parameters, e.g., calibration factors or meter factors. They are used to replicate the transmitter configuration to other devices. The <code>.xfer</code> extension is used to identify replication files. |

3.2.1 Save a configuration file using the display

Prerequisites

If you are planning to use the USB drive, the service port must be enabled. It is enabled by default. However, if you need to enable it, choose **Menu** → **Configuration** → **Security** and set **Service Port** to On.

Procedure

- To save the current configuration to the transmitter's SD card as a backup file:
 - Choose **Menu** → **Configuration** → **Save/Restore Config** → **Save Config to Memory**.
 - Enter the name for this configuration file.

The configuration file is saved to the transmitter's SD card as `yourname.spare`.

- To save the current configuration to a USB drive, as either a backup file or a replication file:
 -  **WARNING**
If the transmitter is in a hazardous area, do not remove the housing cover while the transmitter is powered up. Failure to follow these instructions can cause an explosion resulting in injury or death.

Open the wiring compartment on the transmitter and insert a USB drive into the service port.

- b) Choose **Menu** → **USB Options** → **Transmitter** → **USB Drive** → **Save Active Config to USB Drive**.
- c) Choose Backup or Replicate.
- d) Enter the name for this configuration file.

The configuration file is saved to the USB drive as *yourname.spare* or *yourname.xfer*.

- To copy a configuration file from the transmitter's SD card to the USB drive:

a)  **WARNING**

If the transmitter is in a hazardous area, do not remove the housing cover while the transmitter is powered up. Failure to follow these instructions can cause an explosion resulting in injury or death.

Open the wiring compartment on the transmitter and insert a USB drive into the service port.

- b) Choose **Menu** → **USB Options** → **Transmitter** → **USB Drive** → **Transfer Config File to USB Drive**.
- c) Choose Backup or Replicate.
- d) Select the file that you want to transfer.

The configuration file is copied to the USB drive, using its existing name.

3.2.2 Save a configuration file using ProLink III

Note

When you use ProLink III format for configuration files, you can specify configuration parameters individually or by groups. Therefore, you can use this format for both backup and replication.

Procedure

- To save the current configuration to the transmitter's SD card:
 - a) Choose **Device Tools** → **Configuration Transfer** → **Save Configuration**.
 - b) Select On my 5700 Device Internal Memory and select **Next**.
 - c) Select **Save**.
 - d) Enter the name for this configuration file.
 - e) Set the file type.
 - To save a backup file, set the file type to Backup.
 - To save a replication file, set the file type to Transfer.
 - f) Select **Save**.

The configuration file is saved to the transmitter's SD card as *yourname.spare* or *yourname.xfer*.

- To save the current configuration to your PC, in 5700 format:
 - a) Choose **Device Tools** → **Configuration Transfer** → **Save Configuration**.
 - b) Select On my computer in 5700 device file format and select **Next**.

- c) Select **Save**.
- d) Browse to the desired location, then enter the name for this configuration file.
- e) Set the file type.
 - To save a backup file, set the file type to Backup.
 - To save a replication file, set the file type to Transfer.
- f) Select **Save**.

The configuration file is saved to the specified location as *yourname.spare* or *yourname.xfer*.

- To save the current configuration to your PC, in ProLink III format:
 - a) Choose **Device Tools** → **Configuration Transfer** → **Save Configuration**.
 - b) Select On my computer in ProLink III file format and click **Next**.
 - c) Select **Save**.
 - d) Select the configuration parameters to be included in this file.
 - To save a backup file, select all parameters.
 - To save a replication file, select all parameters except device-specific parameters.
 - e) Select **Save**.
 - f) Browse to the desired location, then enter the name for this configuration file.
 - g) Set the file type to ProLink configuration file.
 - h) Select **Start Save**.

The configuration file is saved to the specified location as *yourname.pcfg*.

3.2.3 Load a configuration file using the display

Prerequisites

You must have a backup file or a replication file available for use.

If you are planning to use the USB drive, the service port must be enabled. It is enabled by default. However, if you need to enable it, choose **Menu** → **Configuration** → **Security** and set **Service Port** to On.

Procedure

- To load either a backup file or a replication file from the transmitter's SD card:
 - a) Choose **Menu** → **Configuration** → **Save/Restore Config** → **Restore Config from Memory**.
 - b) Select **Backup** or **Replicate**.
 - c) Select the file that you want to load.

The file is loaded to working memory and becomes active immediately.

- To load a either a backup file or a replication file from a USB drive:

- a)  **WARNING**
If the transmitter is in a hazardous area, do not remove the housing cover while the transmitter is powered up. Failure to follow these instructions can cause an explosion resulting in injury or death.
- Open the wiring compartment on the transmitter and insert the USB drive containing the backup file or replication file into the service port.
- b) Choose **Menu** → **USB Options** → **USB Drive** → **Transmitter** → **Upload Configuration File**.
- c) Select **Backup** or **Replicate**.
- d) Select the file that you want to load.
- e) Choose Yes or No when prompted to apply the settings.
- Yes: The file is loaded to working memory and becomes active immediately.
 - No: The file is loaded to the transmitter's SD card but not to working memory. You can load it from the SD card to working memory at a later time.

3.2.4 Load a configuration file using ProLink III

You can load a configuration file to the transmitter's working memory. You can load a backup file or a replication file. Two PC file formats are supported: the 5700 format and the ProLink III format.

Note

When you use ProLink III format for configuration files, you can specify configuration parameters individually or by groups. Therefore, you can use this format for both backup and replication.

Procedure

- To load a backup file or replication file from the transmitter's SD card:
 - a) Choose **Device Tools** → **Configuration Transfer** → **Load Configuration**.
 - b) Select **On my 5700 Device Internal Memory** and select **Next**.
 - c) Select **Restore**.
 - d) Set the file type.
 - To load a backup file, set the file type to **Backup**.
 - To load a replication file, set the file type to **Transfer**.
 - e) Select the file that you want to load and select **Load**.

The parameters are written to working memory, and the new settings become effectively immediately.

- To load a backup file or replication file in 5700 format from the PC:
 - a) Choose **Device Tools** → **Configuration Transfer** → **Load Configuration**.
 - b) Select **On my computer in 5700 device file format** and select **Next**.
 - c) Select **Restore**.

- d) Set the file type.
 - To load a backup file, set the file type to Backup.
 - To load a replication file, set the file type to Transfer.
- e) Navigate to the file you want to load, and select it.

The parameters are written to working memory, and the new settings become effectively immediately.

- To load a file in ProLink III format from the PC:
 - a) Choose **Device Tools** → **Configuration Transfer** → **Load Configuration**.
 - b) Select On my computer in ProLink III file format and select **Next**.
 - c) Select the parameters that you want to load.
 - d) Select Load.
 - e) Set the file type to Configuration file.
 - f) Navigate to the file you want to load, and select it.
 - g) Select Start Load.

The parameters are written to working memory, and the new settings become effectively immediately.

3.2.5 Restore the factory configuration

Display	Menu → Configuration → Save/Restore Configuration → Restore Config from Memory
ProLink III	Device Tools → Configuration Transfer → Restore Factory Configuration
Web browser	Service Tool → Download Device Files → Factory Config File (download only, no restoration)

A file containing the factory configuration is always saved in the transmitter's internal memory, and is available for use.

This action is typically used for error recovery or for repurposing a transmitter.

If you restore the factory configuration, the real-time clock, the audit trail, the historian, and other logs are not reset.

Note

Using a web browser, you can download the factory (.cfg) configuration file and view it with a text editor, but you must use ProLink III or the display to restore the factory configuration.

3.2.6 Replicate a transmitter configuration

Replicating a transmitter configuration is a fast method to set up similar or identical measurement points.

Procedure

1. Configure a transmitter and verify its operation and performance.
2. Use any available method to save a replication file from that transmitter.
3. Use any available method to load the replication file to another transmitter.

4. At the replicated transmitter, set device-specific parameters and perform device-specific procedures:
 - a) Set the clock.
 - b) Set the tag, long tag, Modbus address, and related parameters.
 - c) Characterize the transmitter.
 - d) Perform zero validation and take any recommended actions.
 - e) Perform loop tests and take any recommended actions, including mA Output trim.
 - f) Use sensor simulation to verify transmitter response.
5. At the replicated transmitter, make any other configuration changes.
6. Follow your standard procedures to ensure that the replicated transmitter is performing as desired.

4 Configure process measurement

4.1 Configure Sensor Flow Direction Arrow

Display	Menu → Configuration → Process Measurement → Flow Variables → Flow Direction
ProLink III	Device Tools → Configuration → Process Measurement → Flow → Sensor Direction
Web browser	Configuration → Process Measurement → Flow Variables → Sensor Direction

Sensor Flow Direction Arrow is used to accommodate installations in which the Flow arrow on the sensor does not match the majority of the process flow. This typically happens when the sensor is accidentally installed backwards.

Sensor Flow Direction Arrow interacts with **mA Output Direction**, **Frequency Output Direction**, and **Totalizer Direction** to control how flow is reported by the outputs and accumulated by the totalizers and inventories.

The **Sensor Flow Direction Arrow** also affects how flow is reported on the transmitter display and via digital communications. This includes ProLink III, the web browser, and all other user interfaces.

Figure 4-1: Flow arrow on sensor

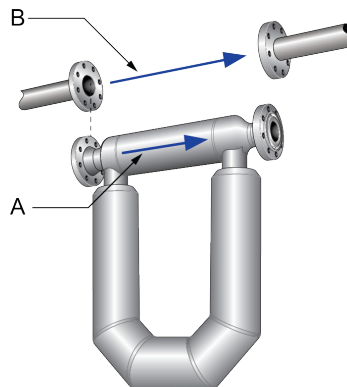

- A. Flow arrow
- B. Actual flow direction

Procedure

Set **Sensor Flow Direction Arrow** as appropriate.

Option	Description
With Arrow	The majority of flow through the sensor matches the Flow arrow on the sensor. Actual forward flow is processed as forward flow.
Against Arrow	The majority of flow through the sensor is opposite to the Flow arrow on the sensor. Actual forward flow is processed as reverse flow.

Tip

Micro Motion sensors are bidirectional. Measurement accuracy is not affected by actual flow direction or the setting of **Sensor Flow Direction Arrow**. **Sensor Flow Direction Arrow** controls only whether actual flow is processed as forward flow or reverse flow.

Related information

[Configure mA Output Direction](#)

[Configure Frequency Output Direction](#)

[Configure Discrete Output Source](#)

[Configure totalizers and inventories](#)

[Effect of Sensor Flow Direction Arrow on digital communications](#)

4.2 Configure mass flow measurement

The mass flow measurement parameters control how mass flow is measured and reported. The mass total and mass inventory are derived from the mass flow data.

4.2.1 Configure Mass Flow Measurement Unit

Display	Menu → Configuration → Process Measurement → Flow Variables → Mass Flow Settings → Units
ProLink III	Device Tools → Configuration → Process Measurement → Flow → Mass Flow Rate Unit
Web browser	Configuration → Process Measurement → Flow Variables → Mass Flow Rate Unit

Mass Flow Measurement Unit specifies the unit of measure that will be used for the mass flow rate. The default unit used for mass total and mass inventory is derived from this unit.

Procedure

Set **Mass Flow Measurement Unit** to the unit you want to use.

Default: g/sec (grams per second)

Tip

If the measurement unit you want to use is not available, you can define a special measurement unit.

Options for Mass Flow Measurement Unit

The transmitter provides a standard set of measurement units for **Mass Flow Measurement Unit**, plus one user-defined special measurement unit. Different communications tools may use different labels for the units.

Unit description	Label		
	Display	ProLink III	Web browser
Grams per second	gram/s	g/sec	g/sec
Grams per minute	gram/min	g/min	g/min
Grams per hour	gram/h	g/hr	g/hr
Kilograms per second	kg/s	kg/sec	kg/sec

Unit description	Label		
	Display	ProLink III	Web browser
Kilograms per minute	kg/min	kg/min	kg/min
Kilograms per hour	kg/h	kg/hr	kg/hr
Kilograms per day	kg/d	kg/day	kg/day
Metric tons per minute	MetTon/min	mTon/min	mTon/min
Metric tons per hour	MetTon/h	mTon/hr	mTon/hr
Metric tons per day	MetTon/d	mTon/day	mTon/day
Pounds per second	lb/s	lbs/sec	lbs/sec
Pounds per minute	lb/min	lbs/min	lbs/min
Pounds per hour	lb/h	lbs/hr	lbs/hr
Pounds per day	lb/d	lbs/day	lbs/day
Short tons (2000 pounds) per minute	STon/min	sTon/min	sTon/min
Short tons (2000 pounds) per hour	STon/h	sTon/hr	sTon/hr
Short tons (2000 pounds) per day	STon/d	sTon/day	sTon/day
Long tons (2240 pounds) per hour	LTon/h	lTon/hr	lTon/hr
Long tons (2240 pounds) per day	LTon/d	lTon/day	lTon/day
Special unit	SPECIAL	Special	Special

Define a special measurement unit for mass flow

Display	Menu → Configuration → Process Measurement → Flow Variables → Mass Flow Settings → Units → SPECIAL
ProLink III	Device Tools → Configuration → Process Measurement → Flow → Mass Flow Rate Unit → Special
Web browser	Configuration → Process Measurement → Flow Variables → Mass Flow Rate Unit → Special

Procedure

1. Specify **Base Mass Unit**.

Base Mass Unit is the existing mass unit that the special unit will be based on.

2. Specify **Base Time Unit**.

Base Time Unit is the existing time unit that the special unit will be based on.

3. Calculate **Mass Flow Conversion Factor** as follows:

a) $x \text{ base units} = y \text{ special units}$

b) **Mass Flow Conversion Factor** = $x \div y$

4. Enter **Mass Flow Conversion Factor**.

The original mass flow rate value is divided by this value.

5. Set **Mass Flow Label** to the name you want to use for the mass flow unit.
6. Set **Mass Total Label** to the name you want to use for the mass total and mass inventory unit.

The special measurement unit is stored in the transmitter. You can configure the transmitter to use the special measurement unit at any time.

Example: Defining a special measurement unit for mass flow

If you want to measure mass flow in ounces per second (oz/sec):

1. Set **Base Mass Unit** to Pounds (lb).
2. Set **Base Time Unit** to Seconds (sec).
3. Calculate **Mass Flow Conversion Factor**:
 - a. $1 \text{ lb/sec} = 16 \text{ oz/sec}$
 - b. **Mass Flow Conversion Factor** = $1 \div 16 = 0.0625$
4. Set **Mass Flow Conversion Factor** to 0.0625.
5. Set **Mass Flow Label** to *oz/sec*.
6. Set **Mass Total Label** to *oz*.

4.2.2 Configure Flow Damping

Display	Menu → Configuration → Process Measurement → Flow Variables → Flow Damping
ProLink III	Device Tools → Configuration → Process Measurement → Flow → Flow Rate Damping
Web browser	Configuration → Process Measurement → Flow Variables → Flow Rate Damping

Flow Damping controls the amount of damping that will be applied to the measured mass flow rate. It affects flow rate process variables that are based on the measured mass flow rate. This includes volume flow rate and gas standard volume flow rate.

Flow Damping also affects specialized flow rate variables such as temperature-corrected volume flow rate (API Referral) and net mass flow rate (concentration measurement).

Damping is used to smooth out small, rapid fluctuations in process measurement. The damping value specifies the time period, in seconds, over which the transmitter will spread changes in the process variable. At the end of the interval, the internal value of the process variable (the damped value) will reflect 63% of the change in the actual measured value.

Procedure

Set **Flow Damping** to the value you want to use.

- Default: 0.64 seconds
- Range: 0 seconds to 60 seconds

Note

If a number greater than 60 is entered, it is automatically changed to 60.

Tip

- A high damping value makes the process variable appear smoother because the reported value changes slowly.
- A low damping value makes the process variable appear more erratic because the reported value changes more quickly.
- The combination of a high damping value and rapid, large changes in flow rate can result in increased measurement error.
- Whenever the damping value is non-zero, the reported measurement will lag the actual measurement because the reported value is being averaged over time.
- In general, lower damping values are preferable because there is less chance of data loss, and less lag time between the actual measurement and the reported value.
- The transmitter automatically rounds off any entered damping value to the nearest valid value. Therefore, the recommended damping value for gas applications should be 3.2 seconds. If you enter 2.56, the transmitter will round it off to 3.2.
- For filling applications, Micro Motion recommends using the default value of 0.04 seconds.

Effect of flow damping on volume measurement

Flow damping affects volume measurement for liquid volume data. Flow damping also affects volume measurement for gas standard volume data. The transmitter calculates volume data from the damped mass flow data.

Interaction between Flow Damping and mA Output Damping

In some circumstances, both **Flow Damping** and **mA Output Damping** are applied to the reported mass flow value.

Flow Damping controls the rate of change in flow process variables. **mA Output Damping** controls the rate of change reported via the mA Output. If **mA Output Process Variable** is set to Mass Flow Rate, and both **Flow Damping** and **mA Output Damping** are set to non-zero values, flow damping is applied first, and the added damping calculation is applied to the result of the first calculation.

4.2.3 Configure Mass Flow Cutoff

Display	Menu → Configuration → Process Measurement → Flow Variables → Mass Flow Settings → Low Flow Cutoff
ProLink III	Device Tools → Configuration → Process Measurement → Flow → Mass Flow Cutoff
Web browser	Configuration → Process Measurement → Flow Variables → Mass Flow Cutoff

Mass Flow Cutoff specifies the lowest mass flow rate that will be reported as measured. All mass flow rates below this cutoff will be reported as 0.

Procedure

Set **Mass Flow Cutoff** to the value you want to use.

- Default: A sensor-specific value set at the factory. If your transmitter was ordered without a sensor, the default may be 0.0.

- Recommendation: 0.5% of maximum flow rate of the attached sensor. See the sensor specifications.

Important

Do not use your meter for measurement with **Mass Flow Cutoff** set to 0.0 g/sec. Ensure that **Mass Flow Cutoff** is set to the value that is appropriate for your sensor.

Effect of Mass Flow Cutoff on volume measurement

Mass Flow Cutoff does not affect volume measurement. Volume data is calculated from the actual mass data rather than the reported value.

Volume flow has a separate Volume Flow Cutoff that is not affected by the Mass Flow Cutoff value.

Interaction between Mass Flow Cutoff and mA Output Cutoff

Mass Flow Cutoff defines the lowest mass flow value that the transmitter will report as measured. **mA Output Cutoff** defines the lowest flow rate that will be reported via the mA Output. If **mA Output Process Variable** is set to Mass Flow Rate, the mass flow rate reported via the mA Output is controlled by the higher of the two cutoff values.

Mass Flow Cutoff affects all reported values and values used in other transmitter behavior (e.g., events defined on mass flow).

mA Output Cutoff affects only mass flow values reported via the mA Output.

Example: Cutoff interaction with mA Output Cutoff lower than Mass Flow Cutoff

Configuration:

- **mA Output Process Variable:** Mass Flow Rate
- **Frequency Output Process Variable:** Mass Flow Rate
- **mA Output Cutoff:** 10 g/sec
- **Mass Flow Cutoff:** 15 g/sec

Result: If the mass flow rate drops below 15 g/sec, mass flow will be reported as 0, and 0 will be used in all internal processing.

Example: Cutoff interaction with mA Output Cutoff higher than Mass Flow Cutoff

Configuration:

- **mA Output Process Variable:** Mass Flow Rate
- **Frequency Output Process Variable:** Mass Flow Rate
- **mA Output Cutoff:** 15 g/sec
- **Mass Flow Cutoff:** 10 g/sec

Result:

- If the mass flow rate drops below 15 g/sec but not below 10 g/sec:
 - The mA Output will report zero flow.
 - The Frequency Output will report the actual flow rate, and the actual flow rate will be used in all internal processing.

- If the mass flow rate drops below 10 g/sec, both outputs will report zero flow, and 0 will be used in all internal processing.

4.3 Configure volume flow measurement for liquid applications

The volume flow measurement parameters control how liquid volume flow is measured and reported. The volume total and volume inventory are derived from volume flow data.

Restriction

You cannot implement both liquid volume flow and gas standard volume flow at the same time. Choose one or the other.

4.3.1 Configure Volume Flow Type for liquid applications

Display	Menu → Configuration → Process Measurement → Flow Variables → Volume Flow Settings → Flow Type → Liquid
ProLink III	Device Tools → Configuration → Process Measurement → Flow → Volume Flow Type → Liquid Volume
Web browser	Configuration → Process Measurement → Flow Variables → Volume Flow Type → Liquid Volume

Volume Flow Type controls whether liquid or gas standard volume flow measurement will be used.

Restriction

Gas standard volume measurement is incompatible with the following applications:

- API Referral
- Concentration measurement
- Advanced Phase Measurement — liquid with gas

For these applications, set **Volume Flow Type** to Liquid.

Procedure

Set **Volume Flow Type** to Liquid.

4.3.2 Configure Volume Flow Measurement Unit for liquid applications

Display	Menu → Configuration → Process Measurement → Flow Variables → Volume Flow Settings → Units
ProLink III	Device Tools → Configuration → Process Measurement → Flow → Volume Flow Rate Unit
Web browser	Configuration → Process Measurement → Flow Variables → Volume Flow Rate Unit

Volume Flow Measurement Unit specifies the unit of measurement that will be displayed for the volume flow rate. The unit used for the volume total and volume inventory is based on this unit.

Prerequisites

Before you configure **Volume Flow Measurement Unit**, be sure that **Volume Flow Type** is set to Liquid.

Procedure

Set **Volume Flow Measurement Unit** to the unit you want to use.

Default: l/sec (liters per second)

Tip

If the measurement unit you want to use is not available, you can define a special measurement unit.

Options for Volume Flow Measurement Unit for liquid applications

The transmitter provides a standard set of measurement units for **Volume Flow Measurement Unit**, plus one user-defined measurement unit. Different communications tools may use different labels for the units.

Unit description	Label		
	Display	ProLink III	Web browser
Cubic feet per second	ft3/s	ft3/sec	ft3/sec
Cubic feet per minute	ft3/min	ft3/min	ft3/min
Cubic feet per hour	ft3/h	ft3/hr	ft3/hr
Cubic feet per day	ft3/d	ft3/day	ft3/day
Cubic meters per second	m3/s	m3/sec	m3/sec
Cubic meters per minute	m3/min	m3/min	m3/min
Cubic meters per hour	m3/h	m3/hr	m3/hr
Cubic meters per day	m3/d	m3/day	m3/day
U.S. gallons per second	gal/s	US gal/sec	US gal/sec
U.S. gallons per minute	gal/m	US gal/min	US gal/min
U.S. gallons per hour	gal/h	US gal/hr	US gal/hr
U.S. gallons per day	gal/d	US gal/day	US gal/day
Million U.S. gallons per day	MMgal/d	mil US gal/day	mil US gal/day
Liters per second	L/s	l/sec	l/sec
Liters per minute	L/min	l/min	l/min
Liters per hour	L/h	l/hr	l/hr
Million liters per day	MML/d	mil l/day	mil l/day
Imperial gallons per second	Impgal/s	Imp gal/sec	Imp gal/sec
Imperial gallons per minute	Impgal/m	Imp gal/min	Imp gal/min
Imperial gallons per hour	Impgal/h	Imp gal/hr	Imp gal/hr
Imperial gallons per day	Impgal/d	Imp gal/day	Imp gal/day
Barrels per second ⁽¹⁾	bbl/s	barrels/sec	barrels/sec
Barrels per minute ⁽¹⁾	bbl/min	barrels/min	barrels/min
Barrels per hour ⁽¹⁾	bbl/h	barrels/hr	barrels/hr
Barrels per day ⁽¹⁾	bbl/d	barrels/day	barrels/day

Unit description	Label		
	Display	ProLink III	Web browser
Beer barrels per second ⁽²⁾	Beer bbl/s	Beer barrels/sec	Beer barrels/sec
Beer barrels per minute ⁽²⁾	Beer bbl/min	Beer barrels/min	Beer barrels/min
Beer barrels per hour ⁽²⁾	Beer bbl/h	Beer barrels/hr	Beer barrels/hr
Beer barrels per day ⁽²⁾	Beer bbl/d	Beer barrels/day	Beer barrels/day
Special unit	SPECIAL	Special	Special

(1) Unit based on oil barrels (42 U.S. gallons).

(2) Unit based on U.S. beer barrels (31 U.S. gallons).

Define a special measurement unit for volume flow

Display	Menu → Configuration → Process Measurement → Flow Variables → Volume Flow Settings → Units → SPECIAL
ProLink III	Device Tools → Configuration → Process Measurement → Flow → Volume Flow Rate Unit → Special
Web browser	Configuration → Process Measurement → Flow Variables → Volume Flow Rate Unit → Special

Procedure

1. Specify **Base Volume Unit**.

Base Volume Unit is the existing volume unit that the special unit will be based on.

2. Specify **Base Time Unit**.

Base Time Unit is the existing time unit that the special unit will be based on.

3. Calculate **Volume Flow Conversion Factor** as follows:

a) $x \text{ base units} = y \text{ special units}$

b) **Volume Flow Conversion Factor** = $x \div y$

4. Enter **Volume Flow Conversion Factor**.

The original volume flow rate value is divided by this conversion factor.

5. Set **Volume Flow Label** to the name you want to use for the volume flow unit.

6. Set **Volume Total Label** to the name you want to use for the volume total and volume inventory unit.

The special measurement unit is stored in the transmitter. You can configure the transmitter to use the special measurement unit at any time.

Example: Defining a special measurement unit for volume flow

You want to measure volume flow in pints per second (pints/sec).

1. Set **Base Volume Unit** to Gallons (gal).
2. Set **Base Time Unit** to Seconds (sec).

3. Calculate the conversion factor:
 - a. 1 gal/sec = 8 pints/sec
 - b. **Volume Flow Conversion Factor** = $1 \div 8 = 0.1250$
4. Set **Volume Flow Conversion Factor** to 0.1250.
5. Set **Volume Flow Label** to pints/sec.
6. Set **Volume Total Label** to pints.

4.3.3 Configure Volume Flow Cutoff

Display	Menu → Configuration → Process Measurement → Flow Variables → Volume Flow Settings → Low Flow Cutoff
ProLink III	Device Tools → Configuration → Process Measurement → Flow → Volume Flow Cutoff
Web browser	Configuration → Process Measurement → Flow Variables → Volume Flow Cutoff

Volume Flow Cutoff specifies the lowest volume flow rate that will be reported as measured. All volume flow rates below this cutoff are reported as 0.

Procedure

Set **Volume Flow Cutoff** to the value you want to use.

- Default: 0.0 l/sec (liters per second)
- Range: 0 l/sec to x l/sec, where x is the sensor's flow calibration factor, multiplied by 0.0002.

Interaction between Volume Flow Cutoff and mA O Cutoff

Volume Flow Cutoff defines the lowest liquid volume flow value that the transmitter will report as measured. **mA O Cutoff** defines the lowest flow rate that will be reported via the mA Output. If **mA Output Process Variable** is set to Volume Flow Rate, the volume flow rate reported via the mA Output is controlled by the higher of the two cutoff values.

Volume Flow Cutoff affects both the volume flow values reported via the outputs and the volume flow values used in other transmitter behavior (e.g., events defined on the volume flow).

mA O Cutoff affects only flow values reported via the mA Output.

Example: Cutoff interaction with mA O Cutoff lower than Volume Flow Cutoff

Configuration:

- **mA Output Process Variable:** Volume Flow Rate
- **Frequency Output Process Variable:** Volume Flow Rate
- **AO Cutoff:** 10 l/sec
- **Volume Flow Cutoff:** 15 l/sec

Result: If the volume flow rate drops below 15 l/sec, volume flow will be reported as 0, and 0 will be used in all internal processing.

Example: Cutoff interaction with mA Cutoff higher than Volume Flow Cutoff

Configuration:

- **mA Output Process Variable:** Volume Flow Rate
- **Frequency Output Process Variable:** Volume Flow Rate
- **AO Cutoff:** 15 l/sec
- **Volume Flow Cutoff:** 10 l/sec

Result:

- If the volume flow rate drops below 15 l/sec but not below 10 l/sec:
 - The mA Output will report zero flow.
 - The Frequency Output will report the actual flow rate, and the actual flow rate will be used in all internal processing.
- If the volume flow rate drops below 10 l/sec, both outputs will report zero flow, and 0 will be used in all internal processing.

4.4 Configure Gas Standard Volume (GSV) flow measurement

The gas standard volume (GSV) flow measurement parameters control how gas standard volume flow is measured and reported.

Restriction

You cannot implement both liquid volume flow and gas standard volume flow at the same time. Choose one or the other.

4.4.1 Configure Volume Flow Type for gas applications

Display	Menu → Configuration → Process Measurement → Flow Variables → Volume Flow Settings → Flow Type → Gas
ProLink III	Device Tools → Configuration → Process Measurement → Flow → Volume Flow Type → Gas Standard Volume
Web browser	Configuration → Process Measurement → Flow Variables → Volume Flow Type → Gas Standard Volume

Volume Flow Type controls whether liquid or gas standard volume flow measurement will be used.

Restriction

Gas standard volume measurement is incompatible with the following applications:

- API Referral
- Concentration measurement
- Advanced Phase Measurement — liquid with gas

For these applications, set **Volume Flow Type** to Liquid.

Procedure

Set **Volume Flow Type** to Gas.

4.4.2 Configure Standard Gas Density

Display	Menu → Configuration → Process Measurement → Flow Variables → Volume Flow Settings → Standard Gas Density
ProLink III	Device Tools → Configuration → Process Measurement → Flow → Standard Density of Gas
Web browser	Configuration → Process Measurement → Flow Variables → Standard Density of Gas

Standard Gas Density is the density of your gas at reference temperature and reference pressure. This is often called *standard density* or *base density*. It is used to calculate the GSV flow rate from the mass flow rate.

Procedure

Set **Standard Gas Density** to the density of your gas at reference temperature and reference pressure.

You can use any reference temperature and reference pressure that you choose. It is not necessary to configure these values in the transmitter.

Tip

ProLink III provides a guided method that you can use to calculate the standard density of your gas if you do not know it.

4.4.3 Configure Gas Standard Volume Flow Measurement Unit

Display	Menu → Configuration → Process Measurement → Flow Variables → Volume Flow Settings → Units
ProLink III	Device Tools → Configuration → Process Measurement → Flow → Gas Standard Volume Flow Unit
Web browser	Configuration → Process Measurement → Flow Variables → Gas Standard Volume Flow Unit

Gas Standard Volume Flow Measurement Unit specifies the unit of measure that will be used for the gas standard volume (GSV) flow rate. The unit used for gas standard volume total and gas standard volume inventory is derived from this unit.

Prerequisites

Before you configure **Gas Standard Volume Flow Measurement Unit**, be sure that **Volume Flow Type** is set to Gas Standard Volume.

Procedure

Set **Gas Standard Volume Flow Measurement Unit** to the unit you want to use.

Default: SCFM (Standard Cubic Feet per Minute)

Tip

If the measurement unit you want to use is not available, you can define a special measurement unit.

Options for Gas Standard Volume Flow Measurement Unit

The transmitter provides a standard set of measurement units for **Gas Standard Volume Flow Measurement Unit**, plus one user-defined special measurement unit. Different communications tools may use different labels for the units.

Unit description	Label		
	Display	ProLink III	Web browser
Normal cubic meters per second	NCMS	Nm3/sec	Nm3/sec
Normal cubic meters per minute	NCMM	Nm3/min	Nm3/min
Normal cubic meters per hour	NCMH	Nm3/hr	Nm3/hr
Normal cubic meters per day	NCMD	Nm3/day	Nm3/day
Normal liter per second	NLPS	NLPS	NLPS
Normal liter per minute	NLPM	NLPM	NLPM
Normal liter per hour	NLPH	NLPH	NLPH
Normal liter per day	NLPD	NLPD	NLPD
Standard cubic feet per second	SCFS	SCFS	SCFS
Standard cubic feet per minute	SCFM	SCFM	SCFM
Standard cubic feet per hour	SCFH	SCFH	SCFH
Standard cubic feet per day	SCFD	SCFD	SCFD
Standard cubic meters per second	SCMS	Sm3/sec	Sm3/sec
Standard cubic meters per minute	SCMM	Sm3/min	Sm3/min
Standard cubic meters per hour	SCMH	Sm3/hr	Sm3/hr
Standard cubic meters per day	SCMD	Sm3/day	Sm3/day
Standard liter per second	SLPS	SLPS	SLPS
Standard liter per minute	SLPM	SLPM	SLPM
Standard liter per hour	SLPH	SLPH	SLPH
Standard liter per day	SLPD	SLPD	SLPD
Special measurement unit	SPECIAL	Special	Special

Define a special measurement unit for gas standard volume flow

Display	Menu → Configuration → Process Measurement → Flow Variables → Volume Flow Settings → Units → SPECIAL
ProLink III	Device Tools → Configuration → Process Measurement → Flow → Gas Standard Volume Flow Unit → Special
Web browser	Configuration → Process Measurement → Flow Variables → Gas Standard Volume Flow Unit → Special

A special measurement unit is a user-defined unit of measure that allows you to report process data, totalizer data, and inventory data in a unit that is not available in the transmitter. A special measurement unit is calculated from an existing measurement unit using a conversion factor.

Procedure

1. Specify **Base Gas Standard Volume Unit**.

Base Gas Standard Volume Unit is the existing gas standard volume unit that the special unit will be based on.

2. Specify **Base Time Unit**.

Base Time Unit is the existing time unit that the special unit will be based on.

3. Calculate **Gas Standard Volume Flow Conversion Factor** as follows:

a) $x \text{ base units} = y \text{ special units}$

b) **Gas Standard Volume Flow Conversion Factor** = $x \div y$

4. Enter the **Gas Standard Volume Flow Conversion Factor**.

The original gas standard volume flow value is divided by this conversion factor.

5. Set **Gas Standard Volume Flow Label** to the name you want to use for the gas standard volume flow unit.

6. Set **Gas Standard Volume Total Label** to the name you want to use for the gas standard volume total and gas standard volume inventory unit.

The special measurement unit is stored in the transmitter. You can configure the transmitter to use the special measurement unit at any time.

Example: Defining a special measurement unit for gas standard volume flow

You want to measure gas standard volume flow in thousands of standard cubic feet per minute.

1. Set **Base Gas Standard Volume Unit** to SCFM.
2. Set **Base Time Unit** to minutes (min).
3. Calculate the conversion factor:
 - a. One thousands of standard cubic feet per minute = 1000 cubic feet per minute
 - b. **Gas Standard Volume Flow Conversion Factor** = $1 \div 1000 = 0.001$
4. Set **Gas Standard Volume Flow Conversion Factor** to 0.001.
5. Set **Gas Standard Volume Flow Label** to KSCFM.
6. Set **Gas Standard Volume Total Label** to KSCF.

4.4.4 Configure Gas Standard Volume Flow Cutoff

Display	Menu → Configuration → Process Measurement → Flow Variables → Volume Flow Settings → Low Flow Cutoff
ProLink III	Device Tools → Configuration → Process Measurement → Flow → Gas Standard Volume Flow Cutoff
Web browser	Configuration → Process Measurement → Flow Variables → Gas Standard Volume Flow Cutoff

Gas Standard Volume Flow Cutoff specifies the lowest gas standard volume flow rate that will be reported as measured. All gas standard volume flow rates below this cutoff will be reported as 0.

Procedure

Set **Gas Standard Volume Flow Cutoff** to the value you want to use.

- Default: 0.0
- Range: 0.0 to any positive value

Interaction between Gas Standard Volume Flow Cutoff and mA Output Cutoff

Gas Standard Volume Flow Cutoff defines the lowest Gas Standard Volume flow value that the transmitter will report as measured. **mA Output Cutoff** defines the lowest flow rate that will be reported via the mA Output. If **mA Output Process Variable** is set to Gas Standard Volume Flow Rate, the volume flow rate reported via the mA Output is controlled by the higher of the two cutoff values.

Gas Standard Volume Flow Cutoff affects both the gas standard volume flow values reported through outputs and the gas standard volume flow values used in other transmitter behavior (for example, events defined on gas standard volume flow).

mA Output Cutoff affects only flow values reported via the mA Output.

Example: Cutoff interaction with mA Output Cutoff lower than Gas Standard Volume Flow Cutoff

Configuration:

- **mA Output Process Variable** for the primary mA Output: Gas Standard Volume Flow Rate
- **Frequency Output Process Variable**: Gas Standard Volume Flow Rate
- **mA Output Cutoff** for the primary mA Output: 10 SLPM (standard liters per minute)
- **Gas Standard Volume Flow Cutoff**: 15 SLPM

Result: If the gas standard volume flow rate drops below 15 SLPM, the volume flow will be reported as 0, and 0 will be used in all internal processing.

Example: Cutoff interaction with mA Output Cutoff higher than Gas Standard Volume Flow Cutoff

Configuration:

- **mA Output Process Variable** for the primary mA Output: Gas Standard Volume Flow Rate
- **Frequency Output Process Variable**: Gas Standard Volume Flow Rate
- **mA Output Cutoff** for the primary mA Output: 15 SLPM (standard liters per minute)
- **Gas Standard Volume Flow Cutoff**: 10 SLPM

Result:

- If the gas standard volume flow rate drops below 15 SLPM but not below 10 SLPM:
 - The primary mA Output will report zero flow.
 - The Frequency Output will report the actual flow rate, and the actual flow rate will be used in all internal processing.

- If the gas standard volume flow rate drops below 10 SLPM, both outputs will report zero flow, and 0 will be used in all internal processing.

4.5 Configure density measurement

The density measurement parameters control how density is measured and reported. Density measurement is used with mass flow rate measurement to determine liquid volume flow rate.

4.5.1 Configure Density Measurement Unit

Display	Menu → Configuration → Process Measurement → Density → Units
ProLink III	Device Tools → Configuration → Process Measurement → Density → Density Unit
Web browser	Configuration → Process Measurement → Density → Density Unit

Density Measurement Unit controls the measurement units that will be used in density calculations and reporting.

Restriction

If the API Referral application is enabled, you cannot change the density measurement unit here. The density measurement unit is controlled by the API table selection.

Procedure

Set **Density Measurement Unit** to the option you want to use.

Default: g/cm³ (grams per cubic centimeter)

Options for Density Measurement Unit

The transmitter provides a standard set of measurement units for **Density Measurement Unit**. Different communications tools may use different labels.

Unit description	Label		
	Display	ProLink III	Web browser
Specific gravity ⁽¹⁾	SGU	SGU	SGU
Grams per cubic centimeter	g/cm3	g/cm3	g/cm3
Grams per liter	g/L	g/l	g/l
Grams per milliliter	g/mL	g/ml	g/ml
Kilograms per liter	kg/L	kg/l	kg/l
Kilograms per cubic meter	kg/m3	kg/m3	kg/m3
Pounds per U.S. gallon	lb/gal	lbs/USgal	lb/USgal
Pounds per cubic foot	lb/ft3	lbs/ft3	lb/ft3
Pounds per cubic inch	lb/in3	lbs/in3	lb/in3

Unit description	Label		
	Display	ProLink III	Web browser
Degrees API	API	API	°API
Short ton per cubic yard	STon/yd3	sT/yd3	ST/yd3

(1) Non-standard calculation. This value represents line density divided by the density of water at 60 °F (15.6 °C).

4.5.2 Configure Density Damping

Display	Menu → Configuration → Process Measurement → Density → Damping
ProLink III	Device Tools → Configuration → Process Measurement → Density → Density Damping
Web browser	Configuration → Process Measurement → Density → Density Damping

Density Damping controls the amount of damping that will be applied to density data.

Damping is used to smooth out small, rapid fluctuations in process measurement. The damping value specifies the time period, in seconds, over which the transmitter will spread changes in the process variable. At the end of the interval, the internal value of the process variable (the damped value) will reflect 63% of the change in the actual measured value.

Procedure

Set **Density Damping** to the desired value.

- Default: 1.28 seconds
- Range: 0.0 to 60 seconds

Tip

- A high damping value makes the process variable appear smoother because the reported value changes slowly.
- A low damping value makes the process variable appear more erratic because the reported value changes more quickly.
- The combination of a high damping value and rapid, large changes in density can result in increased measurement error.
- Whenever the damping value is non-zero, the damped value will lag the actual measurement because the damped value is being averaged over time.
- In general, lower damping values are preferable because there is less chance of data loss, and less lag time between the actual measurement and the damped value.
- If a number greater than 60 is entered, it is automatically changed to 60.

Effect of Density Damping on volume measurement

Density Damping affects liquid volume measurement. Liquid volume values are calculated from the damped density value rather than the measured density value. **Density Damping** does not affect gas standard volume measurement.

Interaction between Density Damping and mA Output Damping

When the mA Output is configured to report density, both **Density Damping** and **mA Output Damping** are applied to the reported density value.

Density Damping controls the rate of change in the value of the process variable in transmitter memory. **mA Output Damping** controls the rate of change reported via the mA Output.

If **mA Output Source** is set to Density, and both **Density Damping** and **mA Output Damping** are set to non-zero values, density damping is applied first, and the mA Output damping calculation is applied to the result of the first calculation. This value is reported over the mA Output.

4.5.3 Configure Density Cutoff

Display	Menu → Configuration → Process Measurement → Density → Cutoff
ProLink III	Device Tools → Configuration → Process Measurement → Density → Density Cutoff
Web browser	Configuration → Process Measurement → Density → Density Cutoff

Density Cutoff specifies the lowest density value that will be reported as measured. All density values below this cutoff will be reported as 0.

Procedure

Set **Density Cutoff** to the value you want to use.

- Default: 0.2 g/cm³
- Range: 0.0 g/cm³ to 0.5 g/cm³

Effect of Density Cutoff on volume measurement

Density Cutoff affects liquid volume measurement. If the density value goes below **Density Cutoff**, the volume flow rate is reported as 0.

4.6 Configure temperature measurement

The temperature measurement parameters control how temperature data is processed. Temperature data is used in several different ways, including temperature compensation, API Referral, and concentration measurement.

4.6.1 Configure Temperature Measurement Unit

Display	Menu → Configuration → Process Measurement → Temperature → Units
ProLink III	Device Tools → Configuration → Process Measurement → Temperature → Temperature Unit
Web browser	Configuration → Process Measurement → Temperature → Temperature Unit

Temperature Measurement Unit specifies the unit that will be used for temperature measurement.

Procedure

Set **Temperature Measurement Unit** to the option you want to use.

Default: °C (Celsius)

Options for Temperature Measurement Unit

The transmitter provides a standard set of units for **Temperature Measurement Unit**. Different communications tools may use different labels for the units.

Unit description	Label		
	Display	ProLink III	Web browser
Degrees Celsius	°C	°C	°C
Degrees Fahrenheit	°F	°F	°F
Degrees Rankine	°R	°R	°R
Kelvin	°K	°K	°K

4.6.2 Configure Temperature Damping

Display	Menu → Configuration → Process Measurement → Temperature → Damping
ProLink III	Device Tools → Configuration → Process Measurement → Temperature → Temperature Damping
Web browser	Configuration → Process Measurement → Temperature → Temperature Damping

Temperature Damping controls the amount of damping that will be applied to temperature data from the sensor. **Temperature Damping** is not applied to external temperature data.

Damping is used to smooth out small, rapid fluctuations in process measurement. The damping value specifies the time period, in seconds, over which the transmitter will spread changes in the process variable. At the end of the interval, the internal value of the process variable (the damped value) will reflect 63% of the change in the actual measured value.

Procedure

Set **Temperature Damping** to the desired value.

- Default: 4.8 seconds
- Range: 0.0 to 80 seconds

Note

If a number greater than 80 is entered, it is automatically changed to 80.

Tip

- A high damping value makes the process variable appear smoother because the reported value changes slowly.
- A low damping value makes the process variable appear more erratic because the reported value changes more quickly.

- The combination of a high damping value and rapid, large changes in temperature can result in increased measurement error.
- Whenever the damping value is non-zero, the damped value will lag the actual measurement because the damped value is being averaged over time.
- In general, lower damping values are preferable because there is less chance of data loss, and less lag time between the actual measurement and the damped value.

Effect of Temperature Damping on process measurement

Temperature Damping affects all processes and algorithms that use temperature data from the internal sensor RTD.

Temperature compensation

Temperature compensation adjusts process measurement to compensate for the effect of temperature on the sensor tubes.

API Referral

Temperature Damping affects API Referral process variables only if the transmitter is configured to use temperature data from the sensor. If an external temperature value is used for API Referral, **Temperature Damping** does not affect API Referral process variables.

Concentration measurement

Temperature Damping affects concentration measurement process variables only if the transmitter is configured to use temperature data from the sensor. If an external temperature value is used for concentration measurement, **Temperature Damping** does not affect concentration measurement process variables.

4.7 Configure Pressure Measurement Unit

Display	Menu → Configuration → Process Measurement → Pressure → Units
ProLink III	Device Tools → Configuration → Process Measurement → Pressure Compensation → Pressure Unit
Web browser	Configuration → Process Measurement → Pressure → Pressure Unit

Pressure Measurement Unit controls the measurement unit used for pressure. This unit must match the unit used by the external pressure device.

Pressure data is used for pressure compensation and for API Referral. The device does not measure pressure directly. You must set up a pressure input.

Procedure

Set **Pressure Measurement Unit** to the desired unit.

Default: psi

4.7.1 Options for Pressure Measurement Unit

The transmitter provides a standard set of measurement units for **Pressure Measurement Unit**. Different communications tools may use different labels for the units. In most applications, set **Pressure Measurement Unit** to match the pressure measurement unit used by the remote device.

Unit description	Label		
	Display	ProLink III	Web browser
Feet water @ 68 °F	ftH2O @68°F	Ft Water @ 68°F	Ft Water @68°F
Inches water @ 4 °C	inH2O @4°C	In Water @ 4°C	Not applicable
Inches water @ 60 °F	inH2O @60°F	In Water @ 60°F	Not applicable
Inches water @ 68 °F	inH2O @68°F	In Water @ 68°F	In Water @68°F
Millimeters water @ 4 °C	mmH2O @4°C	mm Water @ 4°C	Not applicable
Millimeters water @ 68 °F	mmH2O @68°F	mm Water @ 68°F	mm Water @68°F
Millimeters mercury @ 0 °C	mmHg @0°C	mm Mercury @ 0°C	mm Mercury @0°C
Inches mercury @ 0 °C	inHg @0°C	In Mercury @ 0°C	In Mercury @0°C
Pounds per square inch	psi	PSI	PSI
Bar	bar	bar	bar
Millibar	mbar	millibar	millibar
Grams per square centimeter	g/cm2	g/cm2	g/cm2
Kilograms per square centimeter	kg/cm2	kg/cm2	kg/cm2
Pascals	Pa	pascals	pascals
Kilopascals	kPA	Kilopascals	Kilopascals
Megapascals	mPA	Megapascals	Not applicable
Torr @ 0 °C	torr	Torr @ 0°C	Torr @0°C
Atmospheres	atm	atms	atms

4.8 Configure Velocity Measurement Unit

Display	Menu → Configuration → Process Measurement → Velocity → Units
ProLink III	Device Tools → Configuration → Process Measurement → Velocity → Unit
Web browser	Configuration → Process Measurement → Velocity → Unit

Velocity Measurement Unit controls the measurement unit used to report velocity.

Procedure

Set **Velocity Measurement Unit** to the desired unit.

Default: m/sec

4.8.1 Options for Velocity Measurement Unit

The transmitter provides a standard set of measurement units for **Velocity Measurement Unit**. Different communications tools may use different labels.

Unit description	Label		
	Display	ProLink III	Web browser
Feet per minute	ft/min	ft/min	ft/min
Feet per second	ft/s	ft/sec	ft/s
Inches per minute	in/min	in/min	in/min
Inches per second	in/s	in/sec	in/s
Meters per hour	m/h	m/hr	m/h
Meters per second	m/s	m/sec	m/s

5 Configure process measurement applications

5.1 Set up the API Referral application

The API Referral application corrects line density to reference temperature and reference pressure according to American Petroleum Institute (API) standards. The resulting process variable is *referred density*.

Restriction

The API Referral application is not compatible with the following applications:

- Gas Standard Volume Measurement (GSV)
- Piecewise linearization (PWL)
- Advanced Phase Measurement
- Concentration measurement

5.1.1 Set up the API Referral application using the display

Enable the API Referral application using the display

The API Referral application must be enabled before you can perform any setup. If the API Referral application was enabled at the factory, you do not need to enable it now.

Prerequisites

The API Referral application must be licensed on your transmitter.

Procedure

1. Choose **Menu** → **Configuration** → **Process Measurement**.
2. Choose **Flow Variables** → **Volume Flow Settings** and ensure that **Flow Type** is set to Liquid.
3. Return to the **Process Measurement** menu.
4. If the concentration measurement application is displayed in the list, choose **Concentration Measurement** and ensure that **Enabled/Disabled** is set to Disabled.

The concentration measurement application and the API Referral application cannot be enabled simultaneously.

5. Enable API Referral.
 - a) Choose **Menu** → **Configuration** → **Process Measurement** → **API Referral**.
 - b) Set **Enabled/Disabled** to Enabled.

Configure API Referral using the display

The API Referral parameters specify the API table, measurement units, and reference values to be used in referred density calculations.

Prerequisites

You will need API documentation for the API table that you select.

Depending on your API table, you may need to know the thermal expansion coefficient (TEC) for your process fluid.

You must know the reference temperature and reference pressure that you want to use.

Procedure

1. Choose **Menu** → **Configure** → **Process Measurement** → **API Referral**.
2. Set **API Table** to the API table that you want to use to calculate referred density.
Each API table is associated with a specific set of equations. Choose your API table based on your process fluid and the measurement unit that you want to use for referred density.
Your choice also determines the API table that will be used to calculate the correction factor for volume (CTPL or CTL).
3. Refer to the API documentation and confirm your table selection.
 - a) Verify that your process fluid falls within range for line density, line temperature, and line pressure.
 - b) Verify that the referred density range of the selected table is adequate for your application.
4. If you chose a C table, enter **Thermal Expansion Coefficient (TEC)** for your process fluid.
Acceptable limits:
 - 230.0×10^{-6} to 930.0×10^{-6} per °F
 - 414.0×10^{-6} to 1674.0×10^{-6} per °C
5. If required, set **Reference Temperature** to the temperature to which density will be corrected in referred density calculations.
The default reference temperature is determined by the selected API table.
6. If required, set **Reference Pressure** to the pressure to which density will be corrected in referred density calculations.
The default reference pressure is determined by the selected API table.

Set up temperature and pressure data for API Referral using the display

The API Referral application uses temperature and, optionally, pressure data in its calculations. You must decide how to provide this data, then perform the required configuration and setup.

Note

Fixed values for temperature or pressure are not recommended. Using a fixed temperature or pressure value may produce inaccurate process data.

Prerequisites

The pressure measurement must be gauge pressure, not atmospheric pressure.

The pressure device must use the pressure unit that is configured in the transmitter.

If you are using an external temperature device, it must use the temperature unit that is configured in the transmitter.

Procedure

1. Choose the method to be used to supply temperature data, and perform the required setup.

Method	Description	Setup
Internal temperature	Temperature data from the on-board temperature sensor (RTD) will be used for all measurements and calculations. No external temperature data will be available.	<ol style="list-style-type: none"> Choose Menu → Configuration → Process Measurement → Temperature. Set External Temperature to Off.
Digital communications	A host writes temperature data to the meter at appropriate intervals. This data will be available in addition to the internal temperature data.	<ol style="list-style-type: none"> Choose Menu → Configuration → Process Measurement → Temperature. Set External Temperature to On. Perform the necessary host programming and communications setup to write temperature data to the transmitter at appropriate intervals.

2. Choose the method to be used to supply pressure data, and perform the required setup.

Method	Description	Setup
Digital communications	A host writes pressure data to the meter at appropriate intervals.	<ol style="list-style-type: none"> Choose Menu → Configuration → Process Measurement → Pressure → External Pressure. Set External Pressure to On. Perform the necessary host programming and communications setup to write pressure data to the transmitter at appropriate intervals.

Postrequisites

Choose **Menu** → **Service Tools** → **Service Data** → **View Process Variables** and verify the values for External Temperature and External Pressure.

Need help?

If the value is not correct:

- Ensure that the external device and the meter are using the same measurement unit.
- For digital communications, verify that the host has access to the required data.

5.1.2 Set up the API Referral application using ProLink III

Enable the API Referral application using ProLink III

Prerequisites

The API Referral application must be licensed and enabled on your transmitter before you can perform any setup. If the API Referral application was enabled at the factory, you do not need to enable it now.

Procedure

1. Choose **Device Tools** → **Configuration** → **Process Measurement** → **Flow** and ensure that **Volume Flow Type** is set to Liquid Volume.
2. Choose **Device Tools** → **Configuration** → **Transmitter Options**.
3. If the concentration measurement application is enabled, disable it and select **Apply**.

The concentration measurement application and the API Referral application cannot be enabled simultaneously.

4. Enable **API Referral** and select **Apply**.

Configure API Referral using ProLink III

The API Referral parameters specify the API table, measurement units, and reference values to be used in referred density calculations.

Prerequisites

You will need API documentation for the API table that you select.

Depending on your API table, you may need to know the thermal expansion coefficient (TEC) for your process fluid.

You must know the reference temperature and reference pressure that you want to use.

Procedure

1. Choose **Device Tools** → **Configuration** → **Process Measurement** → **API Referral**.
2. Specify the API table to use to calculate referred density.

Each API table is associated with a specific set of equations.

- a) Set **Process Fluid** to the API table group that your process fluid belongs to.

API table group	Process fluids
A tables	Generalized crude and JP4
B tables	Generalized products: Gasoline, jet fuel, aviation fuel, kerosene, heating oils, fuel oils, diesel, gas oil
C tables	Liquids with a constant base density or known thermal expansion coefficient (TEC). You will be required to enter the TEC for your process fluid.
D tables	Lubricating oils
E tables	NGL (Natural Gas Liquids) and LPG (Liquid Petroleum Gas)

- b) Set **Referred Density Measurement Unit** to the measurement units that you want to use for referred density.
- c) Select **Apply**.

These parameters uniquely identify the API table to be used to calculate referred density. The selected API table is displayed, and the meter automatically changes the density unit, temperature unit, pressure unit, and reference pressure to match the API table.

Your choice also determines the API table that will be used to calculate the correction factor for volume (CTPL or CTL).

Restriction

Not all combinations are supported by the API Referral application. See the list of API tables in this manual.

3. Refer to the API documentation and confirm your table selection.
 - a) Verify that your process fluid falls within range for line density, line temperature, and line pressure.
 - b) Verify that the referred density range of the selected table is adequate for your application.
4. If you chose a C table, enter **Thermal Expansion Coefficient (TEC)** for your process fluid.

Acceptable limits:

 - 230.0×10^{-6} to 930.0×10^{-6} per °F
 - 414.0×10^{-6} to 1674.0×10^{-6} per °C
5. Set **Reference Temperature** to the temperature to which density will be corrected in referred density calculations. If you choose Other, select the temperature measurement unit and enter the reference temperature.
6. Set **Reference Pressure** to the pressure to which density will be corrected in referred density calculations.

Set up temperature and pressure data for API Referral using ProLink III

The API Referral application uses temperature and, optionally, pressure data in its calculations. You must decide how to provide this data, then perform the required configuration and setup.

Note

Fixed values for temperature or pressure are not recommended. Using a fixed temperature or pressure value may produce inaccurate process data.

Prerequisites

The pressure measurement must be gauge pressure, not atmospheric pressure.

The pressure device must use the pressure unit that is configured in the transmitter.

If you are using an external temperature device, it must use the temperature unit that is configured in the transmitter.

Procedure

1. Choose **Device Tools** → **Configuration** → **Process Measurement** → **API Referral**.

2. Choose the method to be used to supply temperature data, and perform the required setup.

Option	Description	Setup
Digital communications	A host writes temperature data to the meter at appropriate intervals. This data will be available in addition to the internal RTD temperature data.	<ol style="list-style-type: none"> Set Line Temperature Source to Fixed Value or Digital Communications. Select Apply. Perform the necessary host programming and communications setup to write temperature data to the meter at appropriate intervals.

3. Choose the method you will use to supply pressure data, and perform the required setup.

Option	Description	Setup
Digital communications	A host writes pressure data to the meter at appropriate intervals.	<ol style="list-style-type: none"> Set Pressure Source to Fixed Value or Digital Communications. Perform the necessary host programming and communications setup to write pressure data to the meter at appropriate intervals.

Postrequisites

If you are using external temperature data, verify the external temperature value displayed in the **Inputs** group on the ProLink III main window.

The current pressure value is displayed in the **External Pressure** field. Verify that the value is correct.

Need help?

If the value is not correct:

- Ensure that the external device and the meter are using the same measurement unit.
- For digital communications, verify that the host has access to the required data.

5.1.3 Set up the API Referral application using a web browser

This section guides you through the tasks required to set up and implement the API Referral application.

Enable API Referral using a web browser

The API Referral application must be enabled before you can perform any setup. If the API Referral application was enabled at the factory, you do not need to enable it now.

Prerequisites

The API Referral application must be licensed on your transmitter.

Procedure

1. Choose **Configuration** → **Transmitter Options** and ensure that **Volume Flow Type** is set to Liquid Volume.

2. If the concentration measurement application is enabled, disable it and select **Apply**.
The concentration measurement application and the API Referral application cannot be enabled simultaneously.
3. Enable **API Referral** and select **Apply**.

Configure API Referral using a web browser

The API Referral parameters specify the API table, measurement units, and reference values to be used in referred density calculations.

Prerequisites

You will need API documentation for the API table that you select.

Depending on your API table, you may need to know the thermal expansion coefficient (TEC) for your process fluid.

You must know the reference temperature and reference pressure that you want to use.

Procedure

1. Choose **Configuration** → **Process Measurement** → **API Referral**.
2. Specify the API table to use to calculate referred density.

Each API table is associated with a specific set of equations.

- a) Set **Process Fluid** to the API table group that belongs to your process fluid.

API table group	Process fluids
A tables	Generalized crude and JP4
B tables	Generalized products: Gasoline, jet fuel, aviation fuel, kerosene, heating oils, fuel oils, diesel, gas oil
C tables	Liquids with a constant base density or known thermal expansion coefficient (TEC). You will be required to enter the TEC for your process fluid.
D tables	Lubricating oils
E tables	NGL (Natural Gas Liquids) and LPG (Liquid Petroleum Gas)

- b) Set **Referred Density Measurement Unit** to the measurement units that you want to use for referred density.
- c) Select **Apply**.

These parameters uniquely identify the API table to be used to calculate referred density. The selected API table is displayed, and the meter automatically changes the density unit, temperature unit, pressure unit, and reference pressure to match the API table.

Your choice also determines the API table that will be used to calculate the correction factor for volume (CTPL or CTL).

Restriction

Not all combinations are supported by the API Referral application. See the list of API tables in this manual.

3. Refer to the API documentation and confirm your table selection.
 - a) Verify that your process fluid falls within range for line density, line temperature, and line pressure.
 - b) Verify that the referred density range of the selected table is adequate for your application.
4. If you chose a C table, enter **Thermal Expansion Coefficient (TEC)** for your process fluid.

Acceptable limits:

 - 230.0×10^{-6} to 930.0×10^{-6} per °F
 - 414.0×10^{-6} to 1674.0×10^{-6} per °C
5. Set **Reference Temperature** to the temperature to which density will be corrected in referred density calculations. If you choose Other, select the temperature measurement unit and enter the reference temperature.
6. Set **Reference Pressure** to the pressure to which density will be corrected in referred density calculations.

Set up temperature and pressure data for API Referral using a web browser

The API Referral application uses temperature and, optionally, pressure data in its calculations. You must decide how to provide this data, then perform the required configuration and setup.

Note

Fixed values for temperature or pressure are not recommended. Using a fixed temperature or pressure value may produce inaccurate process data.

Prerequisites

The pressure measurement must be gauge pressure, not atmospheric pressure.

The pressure device must use the pressure unit that is configured in the transmitter.

If you are using an external temperature device, it must use the temperature unit that is configured in the transmitter.

Procedure

1. Choose **Configuration** → **Process Measurement** → **API Referral**.
2. Choose the method to be used to supply temperature data, and perform the required setup.

Option	Description	Setup
Digital communications	A host writes temperature data to the meter at appropriate intervals. This data will be available in addition to the internal RTD temperature data.	<ol style="list-style-type: none"> a. Set Line Temperature Source to Fixed Value or Digital Communications. b. Click Apply. c. Perform the necessary host programming and communications setup to write temperature data to the meter at appropriate intervals.

3. Choose the method you will use to supply pressure data, and perform the required setup.

Option	Description	Setup
Digital communications	A host writes pressure data to the meter at appropriate intervals.	<ol style="list-style-type: none"> a. Set Pressure Source to Fixed Value or Digital Communications. b. Perform the necessary host programming and communications setup to write pressure data to the meter at appropriate intervals.

Postrequisites

If you are using external temperature data, verify the external temperature value displayed in the **Inputs** group on the ProLink III main window.

The current pressure value is displayed in the **External Pressure** field. Verify that the value is correct.

Need help?

If the value is not correct:

- Ensure that the external device and the meter are using the same measurement unit.
- For digital communications, verify that the host has access to the required data.

5.1.4 API tables supported by the API Referral application

The API tables listed here are supported by the API Referral application.

Table 5-1: API tables, process fluids, measurement units, and default reference values

Process fluid	API tables (calculations) ⁽¹⁾		Referred density (API): unit and range	Default reference temp	Default reference pressure	API standard
	Referred density ⁽²⁾	CTL or CTPL ^{(3) (4)}				
Generalized crude and JP4	5A	6A	Unit: °API Range: 0 to 100 °API	60 °F	0 psi (g)	API MPMS 11.1
	23A	24A	Unit: SGU Range: 0.6110 to 1.0760 SGU	60 °F	0 psi (g)	
	53A	54A	Unit: kg/m ³ Range: 610 to 1075 kg/m ³	15 °C	0 kPa (g)	
Generalized products (gasoline, jet fuel, aviation fuel, kerosene, heating oils, fuel oils, diesel, gas oil)	5B	6B	Unit: °API Range: 0 to 85 °API	60 °F	0 psi (g)	API MPMS 11.1
	23B	24B	Unit: SGU Range: 0.6535 to 1.0760 SGU	60 °F	0 psi (g)	
	53B	54B	Unit: kg/m ³ Range: 653 to 1075 kg/m ³	15 °C	0 kPa (g)	
Liquids with a constant density base or known thermal expansion coefficient ⁽⁵⁾	N/A	6C	Unit: °API	60 °F	0 psi (g)	API MPMS 11.1
	N/A	24C	Unit: SGU	60 °F	0 psi (g)	
	N/A	54C	Unit: kg/m ³	15 °C	0 kPa (g)	
Lubricating oils	5D	6D	Unit: °API Range: -10 to +40 °API	60 °F	0 psi (g)	API MPMS 11.1
	23D	24D	Unit: SGU Range: 0.8520 to 1.1640 SGU	60 °F	0 psi (g)	
	53D	54D	Unit: kg/m ³ Range: 825 to 1164 kg/m ³	15 °C	0 kPa (g)	
NGL (natural gas liquids) and LPG (liquid petroleum gas)	23E	24E	Unit: SGU	60 °F	0 psi (g)	API MPMS 11.2.4
	53E	54E	Unit: kg/m ³	15 °C	0 psi (g)	
	59E	60E	Unit: kg/m ³	20 °C	0 psi (g)	

(1) Each API table represents a specialized equation defined by the American Petroleum Institute for a specific combination of process fluid, line conditions, and output.

- (2) Referred density is calculated from line density. You must specify this table, either directly or by selecting the process fluid and base density measurement unit.
- (3) You do not need to specify this table. It is invoked automatically as a result of the previous table selection.
- (4) CTL is a correction factor based on online temperature. CTPL is a correction factor based on both line pressure and line temperature. Calculation of CTL and CTPL for A, B, C, and D table products is in accordance with API MPMS Chapter 11.1. Calculation of CTL and CTPL for E table products is in accordance with API MPMS Chapters 11.2.2, 11.2.4, and 11.2.5.
- (5) The Thermal Expansion Coefficient (TEC) replaces the referred density calculation. Use the CTL/CTPL table instead.

5.1.5 Process variables from the API Referral application

The API Referral application calculates several different process variables according to API standards.

CTPL	Correction factor based on line temperature and line pressure.
CTL	Correction factor based on line temperature at saturation conditions.
Referred density	The measured density after CTL or CTPL has been applied.
API volume flow	The measured volume flow rate after CTL or CTPL has been applied. Also called <i>corrected volume flow</i> .
Batch-weighted average density	One density value is recorded for each unit of flow (e.g., barrel, liter). The average is calculated from these values. The average is reset when the API totalizer is reset. Not available unless a totalizer has been configured with Source set to Corrected Volume Flow.
Batch-weighted average temperature	One temperature value is recorded for each unit of flow (e.g., barrel, liter). The average is calculated from these values. The average is reset when the API totalizer is reset. Not available unless a totalizer has been configured with Source set to Temperature-Corrected Volume Flow.
API volume total	The total API volume measured by the transmitter since the last API totalizer reset. Also called <i>corrected volume total</i> . Not available unless a totalizer has been configured with Source set to Corrected Volume Flow.
API volume inventory	The total API volume measured by the transmitter since the last API inventory reset. Also called <i>corrected volume inventory</i> . Not available unless an inventory has been configured with Source set to Corrected Volume Flow.

5.2 Set up concentration measurement

The concentration measurement application calculates concentration from line density and line temperature.

5.2.1 Preparing to set up concentration measurement

The procedure for setting up concentration measurement application depends on how your device was ordered and how you want to use the application. Review this information before you begin.

Requirements for concentration measurement

To use the concentration measurement application, the following conditions must be met:

- The concentration measurement application must be enabled.
- The API Referral application must be disabled.

- The gas piecewise linearization (PWL) application must be disabled.
- The Advanced Phase Measurement application must be disabled or set for the Liquid with Gas application.
- A concentration matrix must be loaded into one of the six slots on the transmitter.

Tip

In most cases, the concentration matrix that you ordered was loaded at the factory. If it was not, you have several options for loading a matrix. You can also build a matrix.

- **Temperature Source** must be configured and set up.
- One matrix must be selected as the active matrix (the matrix used for measurement).

Requirements for matrices

A matrix is the set of coefficients used to convert process data to concentration, plus related parameters. The matrix can be saved as a file.

The transmitter requires all matrices to be in .matrix format. You can use ProLink III to load matrices in other formats:

- .edf (used by ProLink II)
- .xml (used by ProLink III)

The transmitter can store matrices in two locations:

- One of the six slots in memory
- The transmitter's SD card

Any matrix in a slot is available for use. In other words, it can be selected as the active matrix and used for measurement. Matrices on the SD card are not available for use. Matrices must be loaded into a slot before they can be used for measurement.

All matrices in slots must use the same derived variable. Matrices on the SD card have no requirement for their derived variables to match.

See the following table for the different ways that you can load matrices.

Table 5-2: Methods to load a matrix file

Action	Display	ProLink III
Load matrix from USB drive to SD card	✓	
Load matrix from computer to slot		✓
Load matrix from SD card to slot	✓	✓

Requirements for derived variables

A *derived variable* is the process variable that a concentration matrix measures. All other process variables are calculated from the derived variable. There are eight possible derived variables. Each matrix is designed for one specific derived variable.

The transmitter can store up to six matrices in six slots. There are additional matrices on the transmitter's SD card. All matrices in the six slots must use the same derived variable. If you change the setting of **Derived Variable**, all matrices are deleted from the six slots. Any matrices on the transmitter's SD card are not affected.

Tip

Always ensure that **Derived Variable** is set correctly before loading matrices into slots.

Derived variables and net flow rate

If you want the transmitter to calculate Net Mass Flow Rate, the derived variable must be set to Mass Concentration (Density). If your matrix is not designed for Mass Concentration (Density), contact customer support for assistance.

If you want the transmitter to calculate Net Volume Flow Rate, the derived variable must be set to Volume Concentration (Density). If your matrix is not designed for Volume Concentration (Density), contact customer support for assistance.

Derived variables based on specific gravity

The following derived variables are based on specific gravity:

- Specific Gravity
- Concentration (Specific Gravity)
- Mass Concentration (Specific Gravity)
- Volume Concentration (Specific Gravity)

If you are using one of these derived variables, two additional parameters can be configured:

- **Reference Temperature of Water** (default setting: 4 °C)
- **Water Density at Reference Temperature** (default setting: 999.99988 kg/m³)

These two parameters are used to calculate specific gravity.

You cannot set these parameters from the display. If the default values are not appropriate, you must use another method to set them.

Optional tasks in setting up concentration measurement

The following tasks are optional:

- Modifying names and labels
- Configuring extrapolation alerts

5.2.2 Set up concentration measurement using the display

This section guides you through most of the tasks related to setting up and implementing the concentration measurement application.

Restriction

This section does not cover building a concentration matrix. For detailed information on building a matrix, see the *Micro Motion Enhanced Density Application Manual*.

Enable concentration measurement using the display

The concentration measurement application must be enabled before you can perform any setup. If the concentration measurement application was enabled at the factory, you do not need to enable it now.

Prerequisites

The concentration measurement application must be licensed on your transmitter.

Disable the following applications before enabling concentration measurement as concentration measurement cannot be enabled at the same time:

- Advanced Phase Measurement — gas with liquid
- API Referral
- Piecewise linearization (PWL)
- Gas Standard Volume

Procedure

1. Choose **Menu** → **Configuration** → **Process Measurement**.
2. Choose **Flow Variables** → **Volume Flow Settings** and ensure that **Flow Type** is set to Liquid.
3. Return to the **Process Measurement** menu.
4. If the API Referral application is displayed in the menu, choose **API Referral** and ensure that **Enabled/Disabled** is set to Disabled.

The concentration measurement application and the API Referral application cannot be enabled simultaneously.

5. If the Advanced Phase Measurement application is displayed in the menu, choose **Advanced Phase Measurement** → **Application Setup** and ensure that **Enabled/Disabled** is set to Disabled.
6. Enable concentration measurement.
 - a) Choose **Menu** → **Configuration** → **Process Measurement** → **Concentration Measurement**.
 - b) Set **Enabled/Disabled** to Enabled.

Load a concentration matrix from a USB drive using the display

At least one concentration matrix must be loaded into one of the six slots on your transmitter. You can load up to six matrices into slots. You can also copy matrices to the transmitter's SD card, and load them into slots at a later time.

Tip

In many cases, concentration matrices were ordered with the device and loaded at the factory. You may not need to load any matrices.

WARNING

If the transmitter is in a hazardous area, do not remove the housing cover while the transmitter is powered up. Failure to follow these instructions can cause an explosion resulting in injury or death.

Prerequisites

The concentration measurement application must be enabled on your device.

For each concentration matrix that you want to load, you need a file containing the matrix data. The transmitter's SD card and the ProLink III installation include a set of standard concentration matrices. Other matrices are available from Micro Motion.

Each concentration matrix file must be in .matrix format.

Tip

- If you have a custom matrix on another device, you can save it to a file, then load it to the current device.
- If you have a matrix file in a different format, you can load it using ProLink III.

The .matrix files must be copied to the root directory of a USB drive.

You must know the derived variable that the matrix is designed to calculate.

Important

- All concentration matrices on your transmitter must use the same derived variable.
- If you change the setting of **Derived Variable**, all existing concentration matrices will be deleted from the six slots on the transmitter, but not from the SD card. Set **Derived Variable** before loading concentration matrices.

Procedure

1. Choose **Menu** → **Configuration** → **Process Measurement** → **Concentration Measurement** → **Configure Application** and ensure that the setting of **Derived Variable** matches the derived variable used by your matrix. If it does not, change it as required and click **Apply**.

Important

If you change the setting of **Derived Variable**, all existing concentration matrices will be deleted from the six slots, but not from the transmitter's SD card. Verify the setting of **Derived Variable** before continuing.

2. Load the matrix.
 - a) Remove the cover from the transmitter's wiring compartment, open the snap flap to access the service port, and insert the USB drive into the service port.
 - b) Choose **Menu** → **USB Options** → **USB Drive** → **Transmitter** → **Upload Configuration File**.
 - c) Set **Config File Type** to Concentration Measurement Matrix.
 - d) Select the .matrix file that you want to load, and wait for the transfer to complete.
3. Choose Yes or No when you are asked if you want to apply the settings.

The transmitter has six slots that are used to store concentration matrices. Any one of these can be used for measurement. The transmitter also has the capability to store multiple concentration matrices on its SD card. These cannot be used for measurement until they are moved to a slot.

Option	Description
Yes	The matrix is saved to the SD card, and the loading process continues with loading the matrix into one of the slots.

Option	Description
No	The matrix is saved to the SD card, and the loading process ends. You must load a matrix into a slot before you can use it for measurement.

- If you chose Yes, select the slot to load this matrix into, and wait until the load is complete. You can load the matrix into any empty slot, or you can overwrite an existing matrix.

Postrequisites

If you loaded the matrix into a slot, choose **Menu** → **Configuration** → **Process Measurement** → **Concentration Measurement** → **Configure Application** → **Active Matrix** and ensure that the matrix is listed.

If you loaded the matrix onto the SD card only, choose **Menu** → **Configuration** → **Process Measurement** → **Concentration Measurement** → **Load Matrix** and ensure that the matrix is listed.

Load a concentration matrix from the SD card using the display

If you have a concentration matrix on the transmitter's SD card, you can load it into one of the six slots on your transmitter. You cannot use the matrix for measurement until it has been loaded into a slot. You can load up to six matrices into slots.

Prerequisites

You must have one or more concentration matrices stored on the transmitter's SD card. The standard matrices are loaded to the SD card at the factory.

You must know the derived variable that the matrix is designed to calculate.

Procedure

- Choose **Menu** → **Configuration** → **Process Measurement** → **Concentration Measurement** and ensure that the setting of **Derived Variable** matches the derived variable used by your matrix. If it does not, change it as required and click **Apply**.

Important

If you change the setting of **Derived Variable**, all existing concentration matrices will be deleted from the six slots, but not from the transmitter's SD card. Verify the setting of **Derived Variable** before continuing.

- Choose **Menu** → **Configuration** → **Process Measurement** → **Concentration Measurement** → **Load Matrix**.
The transmitter displays a list of all matrices that are on the SD card.
- Select the matrix that you want to load.
- Select the slot that you want to load it into.

You can load the matrix into any empty slot, or you can overwrite an existing matrix.

Postrequisites

Choose **Menu** → **Configuration** → **Process Measurement** → **Concentration Measurement** → **Configure Application** → **Active Matrix** and ensure that the matrix is listed.

Set up temperature data using the display

The concentration measurement application uses line temperature data in its calculations. You must decide how to provide this data, then perform the required configuration and setup. Temperature data from the on-board temperature sensor (RTD) is always available. Optionally, you can set up an external temperature device and use external temperature data.

The temperature setup that you establish here will be used for all concentration measurement matrices on this meter.

Important

Line temperature data is used in several different measurements and calculations. It is possible to use the internal RTD temperature in some areas and an external temperature in others. The transmitter stores the internal RTD temperature and the external temperature separately. However, the transmitter stores only one alternate temperature value, which may be either the external temperature or the configured fixed value. Accordingly, if you choose a fixed temperature for some uses, and an external temperature for others, the external temperature will overwrite the fixed value.

Procedure

Choose the method to be used to supply temperature data, and perform the required setup.

Method	Description	Setup
Internal temperature	Temperature data from the on-board temperature sensor (RTD) will be used for all measurements and calculations. No external temperature data will be available.	<ol style="list-style-type: none"> a. Choose Menu → Configuration → Process Measurement → Temperature. b. Set External Temperature to Off.
Digital communications	A host writes temperature data to the meter at appropriate intervals. This data will be available in addition to the internal temperature data.	<ol style="list-style-type: none"> a. Choose Menu → Configuration → Process Measurement → Temperature. b. Set External Temperature to On. c. Perform the necessary host programming and communications setup to write temperature data to the transmitter at appropriate intervals.

Postrequisites

Choose **Menu** → **Service Tools** → **Service Data** → **View Process Variables** and verify the value for External Temperature.

Need help?

If the value is not correct:

- Ensure that the external device and the meter are using the same measurement unit.
- For digital communications, verify that the host has access to the required data.

Modify matrix names and labels using the display

For convenience, you can change the name of a concentration matrix and the label used for its measurement unit. This does not affect measurement.

Procedure

1. Choose **Menu** → **Configuration** → **Process Measurement** → **Concentration Measurement** → **Configure Matrix**.
2. Select the matrix that you want to modify.
3. Set **Matrix Name** to the name that will be used for this matrix.
4. Set **Concentration Unit** to the label that will be used for the concentration unit.

If you want to use a custom label, you can use the display to select **Special**. However, you cannot use the display to configure the custom label. You must use another tool to change the label from **Special** to a user-defined string.

Modify extrapolation alerts using the display

You can enable and disable extrapolation alerts, and set extrapolation alert limits. These parameters control the behavior of the concentration measurement application but do not affect measurement directly.

Each concentration matrix is built for a specific density range and a specific temperature range. If line density or line temperature goes outside the range, the transmitter will extrapolate concentration values. However, extrapolation may affect accuracy. Extrapolation alerts are used to notify the operator that extrapolation is occurring.

Each concentration matrix has its own extrapolation alert limits.

Procedure

1. Choose **Menu** → **Configuration** → **Process Measurement** → **Concentration Measurement** → **Configure Matrix**.
2. Select the matrix that you want to modify.
3. Set **Extrapolation Limit** to the point, in percent, at which an extrapolation alert will be posted.
4. Choose **Menu** → **Configuration** → **Process Measurement** → **Concentration Measurement** → **Configure Application** → **Extrapolation Alerts**.
5. Enable or disable the high and low limit alerts for temperature and density as desired.

Example: Extrapolation alerts in action

If **Extrapolation Limit** is set to 5%, **High Limit (Temp)** is enabled, and the active matrix is built for a temperature range of 40 °F (4.4 °C) to 80 °F (26.7 °C), a high-temperature extrapolation alert will be posted if line temperature goes above 82 °F (27.8 °C).

Select the active concentration matrix using the display

You must select the concentration matrix to be used for measurement. Although the transmitter can store up to six concentration matrices, only one matrix can be used for measurement at any one time.

Procedure

1. Choose **Menu** → **Configuration** → **Process Measurement** → **Concentration Measurement** → **Configure Application**.
2. Set **Active Matrix** to the matrix you want to use.

5.2.3 Set up concentration measurement using ProLink III

This section guides you through the tasks required to set up, configure, and implement concentration measurement.

Enable concentration measurement using ProLink III

The concentration measurement application must be enabled before you can perform any setup. If the concentration measurement application was enabled at the factory, you do not need to enable it now.

Prerequisites

The concentration measurement application must be licensed on your transmitter.

Disable the following applications before enabling concentration measurement as concentration measurement cannot be enabled at the same time:

- Advanced Phase Measurement — gas with liquid
- API Referral
- Piecewise linearization (PWL)
- Gas Standard Volume

Procedure

1. Choose **Device Tools** → **Configuration** → **Process Measurement** → **Flow** and ensure that **Volume Flow Type** is set to Liquid Volume.
2. Choose **Device Tools** → **Configuration** → **Process Measurement** → **Advance Phase Measurement** → **APM Status** and ensure that **Application Status** is set to Disable or Liquid with Gas.
3. Choose **Device Tools** → **Configuration** → **Transmitter Options**.
4. Disable API Referral and set the Advance Phase Measurement application to Disabled or Single Liquid.
5. Disable gas Piecewise Linearization (PWL), and set the Advance Phase Measurement application to Disabled or Single Liquid.
6. Set **Concentration Measurement** to Enabled and select **Apply**.

Load a concentration matrix using ProLink III

At least one concentration matrix must be loaded onto your transmitter. You can load up to six.

Prerequisites

The concentration measurement application must be enabled on your device.

For each concentration matrix that you want to load, you need a file containing the matrix data. The ProLink III installation includes a set of standard concentration matrices. Other matrices are available from Micro Motion. The file can be on your computer or in the transmitter's internal memory.

The file must be in one of the formats that ProLink III supports. This includes:

- .xml (ProLink III)
- .matrix (5700)

If you are loading an .xml file, you must know the following information for your matrix:

- The derived variable that the matrix is designed to calculate
- The density unit that the matrix was built with
- The temperature unit that the matrix was built with

If you are loading a .matrix file, you must know the derived variable that the matrix is designed to calculate.

Important

- All concentration matrices on your transmitter must use the same derived variable.
- If you change the setting of **Derived Variable**, all existing concentration matrices will be deleted from the six slots on the transmitter, but not from the transmitter's SD card. Set **Derived Variable** before loading concentration matrices.
- ProLink III loads matrices directly to one of the transmitter's six slots.

Tip

In many cases, concentration matrices were ordered with the device and loaded at the factory. You may not need to load any matrices.

Restriction

You cannot use ProLink III to load a matrix to the transmitter's SD card.

Procedure

1. If you are loading an .xml file, choose **Device Tools** → **Configuration** → **Process Measurement** → **Line Density** and set **Density Unit** to the density unit used by your matrix.

Important

When you load a matrix in one of these formats, if the density unit is not correct, concentration data will be incorrect. The density units must match at the time of loading. You can change the density unit after the matrix is loaded.

2. If you are loading an .xml file, choose **Device Tools** → **Configuration** → **Process Measurement** → **Line Temperature** and set **Temperature Unit** to the temperature unit used by your matrix.

Important

When you load a matrix in one of these formats, if the temperature unit is not correct, concentration data will be incorrect. The temperature units must match at the time of loading. You can change the temperature unit after the matrix is loaded.

3. Choose **Device Tools** → **Configuration** → **Process Measurement** → **Concentration Measurement**. The **Concentration Measurement** window is displayed. It is organized into steps that allow you to perform several different setup and configuration tasks. For this task, you will not use all the steps.

4. In Step 1, ensure that the setting of **Derived Variable** matches the derived variable used by your matrix. If it does not, change it as required and select **Apply**.

Important

If you change the setting of **Derived Variable**, all existing concentration matrices will be deleted from the six slots. Verify the setting of **Derived Variable** before continuing.

5. Load one or more matrices.
 - a) In Step 2, set **Matrix Being Configured** to the location (slot) to which the matrix will be loaded.
 - b) To load a .xml file from your computer, select **Load Matrix from File**, navigate to the file, and load it.
 - c) To load a .matrix file from your computer, select **Load Matrix from My Computer**, navigate to the file, and load it.
 - d) To load a .matrix file from the transmitter's internal memory, select **Load Matrix from 5700 Device Memory**, navigate to the file on the transmitter, and load it.
 - e) Repeat until all required matrices are loaded.

Set reference temperature values for specific gravity using ProLink III

When **Derived Variable** is set to any option based on specific gravity, you must set the reference temperature for water, then verify the density of water at the configured reference temperature. These values affect specific gravity measurement.

This requirement applies to the following derived variables:

- Specific Gravity
- Concentration (Specific Gravity)
- Mass Concentration (Specific Gravity)
- Volume Concentration (Specific Gravity)

Procedure

1. Choose **Device Tools** → **Configuration** → **Process Measurement** → **Concentration Measurement**. The **Concentration Measurement** window is displayed. It is organized into steps that allow you to perform several different setup and configuration tasks. For this task, you will not use all the steps.
2. Scroll to Step 2, set **Matrix Being Configured** to the matrix you want to modify, and select **Change Matrix**.
3. Scroll to Step 3, then perform the following actions:
 - a) Set **Reference Temperature for Referred Density** to the temperature to which line density will be corrected for use in the specific gravity calculation.
 - b) Set **Reference Temperature for Water** to the water temperature that will be used in the specific gravity calculation.
 - c) Set **Water Density at Reference Temperature** to the density of water at the specified reference temperature.

The transmitter automatically calculates the density of water at the specified temperature. The new value will be displayed the next time that transmitter memory is read. You can enter a different value if you prefer.

4. Select **Apply** at the bottom of Step 3.

Set up temperature data using ProLink III

The concentration measurement application uses line temperature data in its calculations. You must decide how to provide this data, then perform the required configuration and setup. Temperature data from the on-board temperature sensor (RTD) is always available. Optionally, you can set up an external temperature device and use external temperature data.

The temperature setup that you establish here will be used for all concentration measurement matrices on this meter.

Important

Line temperature data is used in several different measurements and calculations. It is possible to use the internal RTD temperature in some areas and an external temperature in others. The transmitter stores the internal RTD temperature and the external temperature separately. However, the transmitter stores only one alternate temperature value, which may be either the external temperature or the configured fixed value. Accordingly, if you choose a fixed temperature for some uses, and an external temperature for others, the external temperature will overwrite the fixed value.

Procedure

1. Choose **Device Tools** → **Configuration** → **Process Measurement** → **Concentration Measurement**.
The **Concentration Measurement** window is displayed. It is organized into steps that allow you to perform several different setup and configuration tasks. For this task, you will not use all the steps.
2. Scroll to Step 4.
3. Choose the method to be used to supply temperature data, and perform the required setup.

Option	Description	Setup
Internal temperature	Temperature data from the on-board temperature sensor (RTD) will be used for all measurements and calculations. No external temperature data will be available.	<ol style="list-style-type: none"> a. Set Line Temperature Source to Internal. b. Click Apply.
Digital communications	A host writes temperature data to the meter at appropriate intervals. This data will be available in addition to the internal RTD temperature data.	<ol style="list-style-type: none"> a. Set Line Temperature Source to Fixed Value or Digital Communications. b. Click Apply. c. Perform the necessary host programming and communications setup to write temperature data to the meter at appropriate intervals.

Postrequisites

If you are using external temperature data, verify the external temperature value displayed in the *Inputs* group on the ProLink III main window.

Need help?

If the value is not correct:

- Ensure that the external device and the meter are using the same measurement unit.
- For digital communications, verify that the host has access to the required data.

Modify matrix names and labels using ProLink III

For convenience, you can change the name of a concentration matrix and the label used for its measurement unit. This does not affect measurement.

Procedure

1. Choose **Device Tools** → **Configuration** → **Process Measurement** → **Concentration Measurement**. The **Concentration Measurement** window is displayed. It is organized into steps that allow you to perform several different setup and configuration tasks. For this task, you will not use all the steps.
2. Scroll to Step 2, set **Matrix Being Configured** to the matrix you want to modify, and click **Change Matrix**.
3. Scroll to Step 3, then perform the following actions:
 - a) Set **Concentration Units Label** to the label that will be used for the concentration unit.
 - b) If you set **Concentration Units Label** to Special, enter the custom label in **User-Defined Label**.
 - c) In **Matrix Name**, enter the name to be used for the matrix.
4. Select **Apply** at the bottom of Step 3.

Modify extrapolation alerts using ProLink III

You can enable and disable extrapolation alerts, and set extrapolation alert limits. These parameters control the behavior of the concentration measurement application but do not affect measurement directly.

Each concentration matrix is built for a specific density range and a specific temperature range. If line density or line temperature goes outside the range, the transmitter will extrapolate concentration values. However, extrapolation may affect accuracy. Extrapolation alerts are used to notify the operator that extrapolation is occurring.

Each concentration matrix has its own extrapolation alert limits.

Procedure

1. Choose **Device Tools** → **Configuration** → **Process Measurement** → **Concentration Measurement**. The **Concentration Measurement** window is displayed. It is organized into steps that allow you to perform several different setup and configuration tasks. For this task, you will not use all the steps.
2. Scroll to Step 2, set **Matrix Being Configured** to the matrix you want to modify, and click **Change Matrix**.
3. Scroll to Step 4.
4. Set **Extrapolation Alert Limit** to the point, in percent, at which an extrapolation alert will be posted.

5. Enable or disable the high and low limit alerts for temperature and density, as desired, and click **Apply**.

Example: Extrapolation alerts in action

If **Extrapolation Limit** is set to 5%, **High Limit (Temp)** is enabled, and the active matrix is built for a temperature range of 40 °F (4.4 °C) to 80 °F (26.7 °C), a high-temperature extrapolation alert will be posted if line temperature goes above 82 °F (27.8 °C).

Select the active concentration matrix using ProLink III

You must select the concentration matrix to be used for measurement. Although the transmitter can store up to six concentration matrices, only one matrix can be used for measurement at any one time.

Procedure

1. Choose **Device Tools** → **Configuration** → **Process Measurement** → **Concentration Measurement**.
2. Scroll to Step 2, set **Active Matrix** to the matrix you want to use and select **Change Matrix**.

5.2.4 Set up concentration measurement using a web browser

This section guides you through the tasks required to set up, configure, and implement concentration measurement.

Enable the concentration measurement application using a web browser

The concentration measurement application must be enabled before you can perform any setup. If the concentration measurement application was enabled at the factory, you do not need to enable it now.

Prerequisites

The concentration measurement application must be licensed on your transmitter.

The API Referral application must not be enabled on your transmitter.

Procedure

1. Choose **Configuration** → **Transmitter Options** and ensure that **Volume Flow Type** is set to Liquid Volume.
2. Under **Permanent Features**, set **Concentration Measurement** to **Enabled** and click **Apply**.

Set reference temperature values for specific gravity using a web browser

When **Derived Variable** is set to any option based on specific gravity, you must set the reference temperature for water, then verify the density of water at the configured reference temperature. These values affect specific gravity measurement.

This requirement applies to the following derived variables:

- Specific Gravity
- Concentration (Specific Gravity)
- Mass Concentration (Specific Gravity)
- Volume Concentration (Specific Gravity)

Procedure

1. Choose **Configuration** → **Process Measurement** → **Concentration Measurement**.
The **Concentration Measurement** page is displayed. It is organized into steps that allow you to perform several different setup and configuration tasks. For this task, you will not use all the steps.
2. Under Step 2, set **Matrix Being Configured** to the matrix you want to modify, and select **Change Matrix**.
3. Under Step 3, perform the following actions:
 - a) Set **Reference Temperature** to the temperature to which line density will be corrected for use in the specific gravity calculation.
 - b) Set **Reference Temperature of Water (Specific Gravity)** to the water temperature that will be used in the specific gravity calculation.
 - c) Set **Water Density at Reference Temperature** to the density of water at the specified reference temperature.

The transmitter automatically calculates the density of water at the specified temperature. The new value will be displayed the next time that transmitter memory is read. You can enter a different value if you want to.
4. Select the **Apply** button at the bottom of Step 3.

Provide temperature data for concentration measurement using a web browser

The concentration measurement application uses line temperature data in its calculations. You must decide how to provide this data, then perform the required configuration and setup. Temperature data from the on-board temperature sensor (RTD) is always available. Optionally, you can set up an external temperature device and use external temperature data.

The temperature setup that you establish here will be used for all concentration measurement matrices on this meter.

Procedure

1. Choose **Configuration** → **Process Measurement** → **Concentration Measurement**.
The **Concentration Measurement** page is displayed. It is organized into steps that allow you to perform several different setup and configuration tasks. For this task, you will not use all the steps.
2. Scroll to Step 4.
3. Choose the method to be used to supply temperature data, and perform the required setup.

Option	Description	Setup
Internal RTD temperature data	Temperature data from the on-board temperature sensor (RTD) is used.	a. Under Line Temperature Data , set Source to RTD. b. Click Apply .

Option	Description	Setup
Digital communications	A host writes temperature data to the meter at appropriate intervals. This data will be available in addition to the internal RTD temperature data.	<ol style="list-style-type: none"> Under Line Temperature Data, set Source to Fixed Value or Digital Communications. Click Apply.

Postrequisites

If you are using external temperature data, verify the external temperature value displayed on the **Process Monitor** page.

Need help?

If the value is not correct:

- Ensure that the external device and the meter are using the same measurement unit.
- For digital communications, verify that the host has access to the required data.

Modify matrix names and labels using the a web browser

For convenience, you can change the name of a concentration matrix and the label used for its measurement unit. This does not affect measurement.

Procedure

1. Choose **Configuration** → **Process Measurement** → **Concentration Measurement**.
The **Concentration Measurement** page is displayed. It is organized into steps that allow you to perform several different setup and configuration tasks. For this task, you will not use all the steps.
2. Scroll to Step 2, set **Matrix Being Configured** to the matrix you want to modify, and select **Change Matrix**.
3. Scroll to Step 3, then perform the following actions:
 - a) Set **Concentration Units Label** to the label that will be used for the concentration unit.
 - b) If you set **Concentration Units Label** to Special, enter the custom label in **User-Defined Label**.
 - c) In **Matrix Name**, enter the name to be used for the matrix.
4. Select the **Apply** button at the bottom of Step 3.

Modify extrapolation alerts for concentration measurement using a web browser

You can enable and disable extrapolation alerts, and set extrapolation alert limits. These parameters control the behavior of the concentration measurement application but do not affect measurement directly.

Each concentration matrix is built for a specific density range and a specific temperature range. If line density or line temperature goes outside the range, the transmitter will extrapolate concentration values. However, extrapolation may affect accuracy. Extrapolation alerts are used to notify the operator that extrapolation is occurring.

Each concentration matrix has its own extrapolation alert limits.

Procedure

1. Choose **Configuration** → **Process Measurement** → **Concentration Measurement**.
The **Concentration Measurement** window is displayed. It is organized into steps that allow you to perform several different setup and configuration tasks. For this task, you will not use all the steps.
2. Scroll to Step 2, set **Matrix Being Configured** to the matrix you want to modify, and click **Change Matrix**.
3. Scroll to Step 4.
4. Set **Extrapolation Alarm Limit** to the point, in percent, at which an extrapolation alert will be posted.
5. Enable or disable the high and low limit alerts for temperature and density, as desired, and click **Apply**.

Example: Extrapolation alerts in action

If **Extrapolation Alarm Limit** is set to 5%, **High Extrapolation Limit (Temperature)** is enabled, and the active matrix is built for a temperature range of 40 °F (4.4 °C) to 80 °F (26.7 °C), a high-temperature extrapolation alert will be posted if line temperature goes above 82 °F (27.8 °C).

Select the active concentration matrix using a web browser

You must select the concentration matrix to be used for measurement. Although the transmitter can store up to six concentration matrices, only one matrix can be used for measurement at any one time.

Procedure

1. Choose **Configuration** → **Process Measurement** → **Concentration Measurement**.
The **Concentration Measurement** page is displayed. It is organized into steps that allow you to perform several different setup and configuration tasks. For this task, you will not use all the steps.
2. Scroll to Step 2, set **Active Matrix** to the matrix you want to use and click **Change Matrix**.

5.3 Configure the batching application

5.3.1 Configure global batching parameters

Display	Menu → Configuration → Process Measurement → Batcher → Global
ProLink III	Device Tools → Configuration → Batcher → Batch Settings
Web browser	Configuration → Process Measurement → Batcher → Batch Settings

The global batching parameters apply to all batch presets and all batches.

Procedure

1. Set the flow source to the process variable that will be used to configure and measure the batch.

Note

This field is named **Batch Variable** in the display.

Options	Description
Mass Flow Rate	The batch is measured by mass, using the current mass unit.
Volume Flow Rate	The batch is measured by volume, using the current volume unit.

Options	Description
API Corrected Vol Flow	The batch is measured using the API calculated correction factor.
GSV Flow (only if configured)	The batch is measured using the gas standard volume flow rate.
CM Standard Vol Flow (when licensed and enabled)	The batch is measured using the standard volume flow rate at reference temperature.
CM Net Volume Flow (when licensed and enabled)	The batch is measured using the net volume flow rate at reference temperature.
CM Net Mass Flow (when licensed and enabled)	The batch is measured using the net mass flow rate.

Example

The current measurement unit for mass flow rate is g/sec. The batch will be configured and measured in g (grams).

- Set the maximum target to the largest batch that will be allowed.
 - Default: 999999999.0 kg or the equivalent value in the configured measurement unit
 - Range: Unlimited

If you try to set the batch target to a larger amount, the transmitter will reject the setting.
- Set the maximum batch time to the maximum number of seconds that a batch will be allowed to run.

If the batch does not reach its target before this period expires, the batch is halted automatically and an alert is posted.

 - Default: 0 seconds
 - Range: 0 to 86,400 seconds (1 day)

If **Maximum Fill Time** is set to 0, the control is disabled and no maximum time is applied to batches.

5.3.2 Configure batch presets

Display	Menu → Configuration → Process Measurement → Batcher → Presets
ProLink III	Device Tools → Configuration → Batcher → Preset Configurations
Web browser	Configuration → Process Measurement → Batcher → Preset Configurations

A batch preset is a predefined group of batching parameters. You can define and save up to six batch presets.

When you run a batch, you must choose a preset. You can modify the batch target before you run the batch. All other settings are fixed.

Procedure

- Select the preset number that you want to configure.
- Set the preset name to the name to be used for this preset.

The name can be up to eight characters in length. Valid characters include A-Z and 0-9.
- Set the preset target to the size of the batch.

When the transmitter has measured the specified amount and applied the selected form of AOC, it closes the valve.

4. Optional: Set the preset end warning point to the point in the batch at which a Modbus coil will be set. The end warning allows the transmitter to alert the operator to the end of batch. The operator can prepare for the end of the batch, e.g., by adjusting the flow rate to avoid overflow.
5. Enable or disable the preset as desired.

Note

This field is named **Preset Status** in the display.

Option	Description
Enabled (On)	The preset is available for use. You can select it to run a batch.
Disabled (Off)	The preset is not available for use. You cannot select it to run a batch. You can always enable it at a later time.

Preset 1 is always enabled and cannot be disabled.

5.3.3 Configure a DO for valve control

Display	Menu → Configuration → Inputs/Outputs
ProLink III	Device Tools → Configuration → I/O → Channels
Web browser	Configuration → Process Measurement → Inputs/Outputs → Channel C → Discrete Output

The transmitter runs a batch by opening and closing a valve. You can optionally configure a Discrete Output (DO) to send the open and close commands to the valve.

Prerequisites

- Channel C must be available for valve control.
- The selected channel must be wired to the valve.
- The selected channel and the valve must be powered by a power supply, not by the transmitter.

Procedure

1. Verify the wiring between the selected channel and the valve.
2. Configure the selected channel to operate as a Discrete Output.
 - a) Set Channel C to operate as a Discrete Output.
 - b) Set **Power Source** to External.
3. Configure the channel for valve control.
 - a) Do one of the following depending on which tool you are using:

Tool	Steps
Display	<ol style="list-style-type: none"> 1. Select the Discrete Output to be used for valve control. 2. Choose I/O Settings.

Tool	Steps
ProLink III	<ol style="list-style-type: none"> 1. Navigate to Device Tools → Configuration → I/O → Outputs → Discrete Output. 2. Select the Discrete Output to be used for valve control.
Web browser	Continue to the next step to set the source, polarity, and fault action.

b) Set **Source** to the batch primary valve.

c) Set **Polarity** to match the wiring.

The ON state of the Discrete Output must open the valve, and the OFF state must close the valve.

d) Set **Fault Action** so that the valve will be closed if a fault occurs.

The appropriate setting is either Upscale or Downscale. The setting to use for your installation depends on your valve type, your wiring, and your setting for **Polarity**.

5.3.4 Configure AOC

Display	Menu → Configuration → Process Measurement → Batchers → AOC
ProLink III	Device Tools → Configuration → Batchers → Batchers Options
Web browser	Configuration → Process Measurement → Batchers → Batchers Options

Automatic Overshoot Compensation (AOC) adjusts the timing of the valve close command to minimize overshoot. The valve close command is sent before the target is reached, to compensate for the time required for the valve to close completely. AOC is applied to all presets and all batches.

There are three options for AOC:

- Compensation Off** The transmitter sends the close command when the measured batch total reaches the configured target.
- Fixed Compensation Value** The transmitter sends the close command when the measured batch total equals the target minus the value configured for **Fixed Overshoot Compensation**. This value is configured in the current mass or volume unit, and applies to all presets.
- AOC Algorithm** The transmitter compares the actual measured amount of each batch to the batch target, and determines the adjustment by calibrating itself according to an internal algorithm. You can choose to stop AOC calibration when you are satisfied with the result, or you can set up rolling (continuous) AOC calibration.

Procedure

- To turn compensation off:

Tool	Steps
Display	Set Compensation Mode to Off.

Tool	Steps
ProLink III	Set AOC Compensation Mode to Compensation Off.
Web browser	Set AOC Compensation Mode to Compensation Off.

- To use the Fixed Compensation Value option:
 - a) Set the AOC compensation mode to fixed.

Tool	Steps
Display	Set Compensation Mode to Fixed.
ProLink III	Set AOC Compensation Mode to Fixed Compensation Value.
Web browser	Set AOC Compensation Mode to Fixed Compensation Value.

- b) Set the fixed value or the fixed overshoot compensation to the quantity to be subtracted from the batch target.

Important

Adjust the fixed value:

- Whenever the process changes (e.g., flow rate, process fluid)
- Whenever you change any configuration parameter that can affect flow measurement (e.g., damping)

- To use the AOC Algorithm option:

Tool	Steps
Display	Set Compensation Mode to AOC.
ProLink III	Set AOC Compensation Mode to AOC Algorithm.
Web browser	Set AOC Compensation Mode to AOC Algorithm.

6 Configure advanced options for process measurement

6.1 Configure Response Time

Display	Menu → Configuration → Process Measurement → Response Time
ProLink III	Device Tools → Configuration → Process Measurement → Response Time
Web browser	Configuration → Process Measurement → Response Time

Response Time controls the speed of various internal processes that are involved in retrieving electronic data from the sensor and converting it to process data.

Response Time affects all process and diagnostic variables.

Restriction

Response Time is configurable only if you are using the enhanced core processor. If you are using the standard core processor, **Response Time** is set to Low Filtering and cannot be changed.

Procedure

Set **Response Time** as desired.

Option	Description
Normal	Appropriate for typical applications.
High Filtering	Slower response. Appropriate for applications with significant amount of entrained gas or process noise.
Low Filtering	Fastest response. Appropriate for proving or filling applications.
Service	Do not select unless directed by Micro Motion personnel.

6.2 Detect and report two-phase flow

Two-phase flow (gas in a liquid process or liquid in a gas process) can cause a variety of process control issues. The transmitter provides two methods to detect and report or respond to two-phase flow.

6.2.1 Detect two-phase flow using density

Display	Menu → Configuration → Process Measurement → Density
ProLink III	Device Tools → Configuration → Process Measurement → Density
Web browser	Configuration → Process Measurement → Density

The transmitter can use line density data to detect two-phase flow (gas in a liquid process or liquid in a gas process). The density limits are user-specified. When two-phase flow is detected, an alert is posted.

Procedure

1. Set **Two-Phase Flow Low Limit** to the lowest density value that is considered normal in your process.

Values below this will cause the transmitter to post a Process Aberration alert.

Tip

Gas entrainment can cause your process density to drop temporarily. To reduce the occurrence of two-phase flow alerts that are not significant to your process, set **Two-Phase Flow Low Limit** slightly below your expected lowest process density.

You must enter **Two-Phase Flow Low Limit** in g/cm³, even if you configured another unit for density measurement.

- Default: 0 g/cm³
- Range: 0 g/cm³ to the sensor limit

2. Set **Two-Phase Flow High Limit** to the highest density value that is considered normal in your process.

Values above this will cause the transmitter to post a Process Aberration alert.

Tip

To reduce the occurrence of two-phase flow alerts that are not significant to your process, set **Two-Phase Flow High Limit** slightly above your expected highest process density.

You must enter **Two-Phase Flow High Limit** in g/cm³, even if you configured another unit for density measurement.

- Default: 5 g/cm³
- Range: 5 g/cm³ to the sensor limit

3. Set **Two-Phase Flow Timeout** to the number of seconds that the transmitter will wait for a two-phase flow condition to clear before posting the alert.

- Default: 0 seconds, meaning that the alert will be posted immediately
- Range: 0 to 60 seconds

6.2.2 Detect two-phase flow using sensor diagnostics

Display	Menu → Configuration → Inputs/Outputs → Channel C → I/O Settings → Source
ProLink III	Device Tools → Configuration → I/O → Channels → Channel C → mA Output
Web browser	Configuration → Inputs/Outputs → Channel C → Channel Type → mA Output

The transmitter always monitors sensor diagnostics and applies a two-phase flow algorithm. You can assign an mA Output to report the results of this calculation: single-phase flow, moderate two-phase flow, or severe two-phase flow. Severe two-phase flow can cause the meter to stop functioning.

Procedure

Set **mA Output Source** to Two-Phase Flow Detection.

The signal from the mA Output indicates the current state of the process:

- 12 mA: Single-phase flow
- 16 mA: Moderate two-phase flow
- 20 mA: Severe two-phase flow

6.3 Configure Flow Rate Switch

Display	Menu → Configuration → Alert Setup → Enhanced Events → Flow Rate Switch
ProLink III	Device Tools → Configuration → I/O → Outputs → Discrete Output → Source → Flow Switch Indication
Web browser	Configuration → Inputs/Outputs → Channel C → Discrete Output → Source → Flow Switch Indication

Flow Rate Switch is used to indicate that the flow rate has moved past a user-specified setpoint, in either direction. The flow rate switch is implemented with a user-configurable hysteresis.

Typically, a Discrete Output is assigned as the flow rate switch indicator. The Discrete Output can be wired to an external device such as a light or a horn.

Prerequisites

A channel must be configured as a Discrete Output, and the Discrete Output must be available for this use.

Procedure

1. Set **Discrete Output Source** to Flow Switch, if you have not already done so.
2. Set **Flow Switch Variable** to the flow variable that you want to use to control the flow rate switch.
3. Set **Flow Switch Setpoint** to the value at which the flow switch will be triggered (after **Hysteresis** is applied).

Depending on the polarity of the Discrete Output:

- If the flow rate is below this value, the Discrete Output is ON.
- If the flow rate is above this value, the Discrete Output is OFF.

4. Set **Hysteresis** to the percentage of variation above and below the setpoint that will operate as a deadband.

Hysteresis defines a range around the setpoint within which the flow rate switch will not change.

- Default: 5%
- Range: 0.1% to 10%

Example

If **Flow Switch Setpoint** = 100 g/sec and **Hysteresis** = 5%, and the first measured flow rate is above 100 g/sec, the discrete output is OFF. It will remain OFF unless the flow rate drops below 95 g/sec. If this happens, the discrete output will turn ON, and remain ON until the flow rate rises above 105 g/sec. At this point it turns OFF and will remain OFF until the flow rate drops below 95 g/sec.

Related information

[Configure a Discrete Output](#)

6.4 Configure events

An event occurs when the real-time value of a user-specified process variable moves past a user-defined setpoint. Events are used to provide notification of process changes or to perform specific transmitter actions if a process change occurs.

6.4.1 Configure a basic event

Display	Not available
ProLink III	Device Tools → Configuration → Events → Basic Events
Web browser	Not available

A basic event is used to provide notification of process changes. A basic event occurs (is ON) if the real-time value of a user-specified process variable moves above (HI) or below (LO) a user-defined setpoint. Event status can be queried via digital communications, and a Discrete Output can be configured to report event status.

You can define up to two basic events.

Procedure

1. Select the event that you want to configure.
2. Assign a process variable to the event.
3. Specify **Event Type**.

Option	Description
HI	$x > A$ The event occurs when the value of the assigned process variable (x) is greater than the setpoint (Setpoint A), endpoint not included.
LO	$x < A$ The event occurs when the value of the assigned process variable (x) is less than the setpoint (Setpoint A), endpoint not included.

4. Set a value for **Setpoint A**.
5. Optional: Configure a Discrete Output to switch states in response to the event status.

Related information

[Configure Discrete Output Source](#)

6.4.2 Configure an enhanced event

Display	Menu → Configuration → Alert Setup → Enhanced Events
ProLink III	Device Tools → Configuration → Events → Enhanced Events
Web browser	Configuration → Alert Setup → Enhanced Events

An enhanced event is used to provide notification of process changes and, optionally, to perform specific transmitter actions if the event occurs. An enhanced event occurs (is ON) if the real-time value of a user-

specified process variable moves above (HI) or below (LO) a user-defined setpoint, or in range (IN) or out of range (OUT) with respect to two user-defined setpoints.

You can define up to five enhanced events. For each enhanced event, you can assign one or more actions that the transmitter will perform if the enhanced event occurs.

Procedure

1. Select the event that you want to configure.
2. Assign a process variable to the event.
3. Specify **Event Type**.

Option	Description
HI	$x > A$ The event occurs when the value of the assigned process variable (x) is greater than the setpoint (Setpoint A), endpoint not included.
LO	$x < A$ The event occurs when the value of the assigned process variable (x) is less than the setpoint (Setpoint A), endpoint not included.
IN	$A \leq x \leq B$ The event occurs when the value of the assigned process variable (x) is <i>in range</i> , that is, between Setpoint A and Setpoint B , endpoints included.
OUT	$x \leq A$ or $x \geq B$ The event occurs when the value of the assigned process variable (x) is <i>out of range</i> , that is, less than Setpoint A or greater than Setpoint B , endpoints included.

4. Set values for the required setpoints.
 - For HI and LO events, set **Setpoint A**.
 - For IN and OUT events, set **Setpoint A** and **Setpoint B**.
5. Optional: Configure a Discrete Output to switch states in response to the event status.
6. Optional: Specify the action or actions that the transmitter will perform when the event occurs.

Option	Description
Display	Menu → Configuration → Alert Setup → Enhanced Events, select any enhanced event, and choose Assign Actions
ProLink III	Device Tools → Configuration → I/O → Inputs → Action Assignment

Related information

[Configure Discrete Output Source](#)

Options for Enhanced Event Action

Action	Label	
	Display	PLIII
Standard		
Start sensor zero	Start Zero Calibration	Start Sensor Zero
Totalizers		
Start/stop all totalizers and inventories	Start/stop all totalizers	Start or Stop All Totalizers
Reset totalizer X	Reset Total X	Totalizer X
Reset all totalizers and inventories	Reset All Totals	Reset All Totals
Concentration measurement		
Increment CM matrix	Increment Matrix	Increment ED Curve
Meter verification		
Start meter verification test	Start SMV	Start Meter Verification
Batching		
Begin batch	Begin Batch	Begin Batch
End batch	End Batch	End Batch
Resume batch	Resume Batch	Resume Batch
Increment batch preset	Increment Preset	Increment Batch Preset
Inhibit batch totalizer	Inhibit Totalizer	Inhibit Batch Totalizing
Inhibit batch	Inhibit Batch	Inhibit Batch Start
Inhibit batch flow	Inhibit Flow	Allow Batch End with Flow

6.5 Configure totalizers and inventories

Display	Menu → Configuration → Process Measurement → Totalizers & Inventories
ProLink III	Device Tools → Totalizer Control → Totalizers
Web browser	Configuration → Totalizers/Inventories

The transmitter provides seven configurable totalizers and seven configurable inventories. Each totalizer and each inventory can be configured independently.

Totalizers track the process since the last totalizer reset. Inventories track the process since the last inventory reset. Inventories are typically used to track the process across totalizer resets.

Tip

The default configurations cover the most typical uses of totalizers and inventories. You may not need to change any configurations.

Prerequisites

Before configuring the totalizers and inventories, ensure that the process variables you plan to track are available on the transmitter.

Procedure

1. Select the totalizer or inventory that you want to configure.
2. Set **Totalizer Source** or **Inventory Source** to the process variable that the totalizer or inventory will track.

Option	Description
Mass flow	The totalizer or inventory will track Mass Flow Rate and calculate total mass since the last reset.
Volume flow	The totalizer or inventory will track Volume Flow Rate and calculate total volume since the last reset.
Gas standard volume flow	The totalizer or inventory will track Gas Standard Volume Flow Rate and calculate total volume since the last reset.
Temperature-corrected volume flow	The totalizer or inventory will track Temperature-Corrected Volume Flow Rate and calculate total volume since the last reset.
Standard volume flow	The totalizer or inventory will track Standard Volume Flow Rate and calculate total volume since the last reset.
Net mass flow	The totalizer or inventory will track Net Mass Flow Rate and calculate total mass since the last reset.
Net volume flow	The totalizer or inventory will track Net Volume Flow Rate and calculate total volume since the last reset.

Note

The totalizer/inventory value will not automatically be reset when the source is changed. The user must manually reset the totalizer/inventory.

Tip

If you are using the API Referral application and you want to measure batch-weighted average density or batch-weighted average temperature, you must have a totalizer configured to measure temperature-corrected volume flow.

3. Set **Totalizer Direction** to specify how the totalizer or inventory will respond to forward or reverse flow.

Option	Flow direction	Totalizer and inventory behavior
Forward Only	Forward	Totals increment
	Reverse	Totals do not change
Reverse Only	Forward	Totals do not change
	Reverse	Totals increment
Bidirectional	Forward	Totals increment
	Reverse	Totals decrement

Option	Flow direction	Totalizer and inventory behavior
Absolute Value	Forward	Totals increment
	Reverse	Totals increment

Important

Actual flow direction interacts with **Sensor Flow Direction Arrow** to determine the flow direction that the transmitter uses in processing. See the following table.

Table 6-1: Interaction between actual flow direction and Sensor Flow Direction Arrow

Actual flow direction	Setting of Sensor Flow Direction Arrow	Flow direction sent to outputs and totalizers
Forward (same direction as Flow arrow on sensor)	With Arrow	Forward
	Against Arrow	Reverse
Reverse (opposite from Flow arrow on sensor)	With Arrow	Reverse
	Against Arrow	Forward

- Optional: Set **User Name** to the name you want to use for the inventory or totalizer.

User Name can have a maximum of 16 characters.

The transmitter automatically generates a name for each totalizer and inventory, based on its source, direction, and type.

Example

- **Totalizer Source**=Mass Flow
- **Totalizer Direction**=Forward Only
- Totalizer name=Mass Fwd Total

Example

- **Inventory Source**=Gas Standard Volume Flow
- **Inventory Direction**=Bidirectional
- Inventory name = GSV Bidir Inv

The specified name is used on the transmitter display and on all interfaces that support it. If **User Name** contains only spaces, the transmitter-generated name is used. Not all interfaces support totalizer and inventory names.

Example: Checking for backflow

You suspect that there is a significant amount of backflow through the sensor. To collect data, configure two totalizers as follows:

- **Source**=Mass Flow, **Direction**=Forward Only
- **Source**=Mass Flow, **Direction**=Reverse Only

Reset both totalizers, allow them to run for an appropriate period, then look at the amount of reverse flow as a percentage of forward flow.

Example: Tracking three different process fluids

Three tanks are connected to a loading dock through a single meter. Each tank contains a different process fluid. You want to track each process fluid separately.

1. Set up three totalizers, one for each tank.
2. Name the totalizers `Tank 1`, `Tank 2`, and `Tank 3`.
3. Configure each totalizer as required for the corresponding process fluid.
4. Stop and reset all three totalizers to ensure that the beginning values are 0.
5. When loading from a tank, start the corresponding totalizer, and stop it when the load is finished.

6.5.1 Default settings for totalizers and inventories

Totalizer or inventory	Source (process variable assignment)	Direction	Name of totalizer Name of inventory
1	Mass flow	Forward Only	Mass Fwd Total Mass Fwd Inv
2	Volume flow	Forward Only	Volume Fwd Total Volume Fwd Inv
3	Temperature-corrected volume flow	Forward Only	API Volume Fwd Total API Volume Fwd Inv
4	Gas standard volume flow	Forward Only	GSV Fwd Total GSV Fwd Inv
5	Standard volume flow	Forward Only	Standard Vol Fwd Total Standard Vol Fwd Inv
6	Net mass flow	Forward Only	Net Mass Fwd Total Net Mass Fwd Inv
7	Net volume flow	Forward Only	Net Vol Fwd Total Net Vol Fwd Inv

6.6 Configure logging for totalizers and inventories

Display	Menu → Configuration → Totalizer Log
ProLink III	Device Tools → Configuration → Totalizer Log
Web browser	Configuration → Totalizers/Inventories → Totalizer Log

The transmitter can write the current value of four totalizers or inventories to a log, at user-specified intervals. You can generate a log file from this data for viewing and analysis.

Procedure

1. Specify the date on which totalizer logging will begin.
You must specify a future date. If you try to specify the current date, the transmitter will reject the setting.
2. Specify the time at which totalizer logging will begin.
3. Specify the number of hours between records.
4. Select up to four totalizers or inventories to be logged.

6.7 Configure Process Variable Fault Action

Display	Menu → Configuration → Alert Setup → Output Fault Actions
ProLink III	Device Tools → Configuration → Fault Processing
Web browser	Configuration → Alert Setup → Output Fault Actions

Process Variable Fault Action specifies the values that will be reported via the display and digital communications if the device encounters a fault condition. The values are also sent to the outputs for processing against their configured fault actions.

Procedure

Set **Process Variable Fault Action** as desired.

Default: None

Restriction

If you set **Process Variable Fault Action** to NAN, you cannot set **mA Output Fault Action** or **Frequency Output Fault Action** to None. If you try to do this, the transmitter will not accept the configuration.

Important

- If you want the mA Output to continue reporting process data during fault conditions, you must set both **Process Variable Fault Action** and **mA Output Fault Action** to **None**. If **mA Output Fault Action** is set to **None** and **Process Variable Fault Action** is set to any other option, the mA Output will produce the signal associated with the selection.
- If you want the Frequency Output to continue reporting process data during fault conditions, you must set both **Process Variable Fault Action** and **Frequency Output Fault Action** to **None**. If **Frequency Output Fault Action** is set to **None** and **Process Variable Fault Action** is set to any other option, the Frequency Output will produce the signal associated with the selection.

6.7.1 Options for Process Variable Fault Action

Label			Description
Display	ProLink III	Web browser	
Upscale	Upscale	Upscale	<ul style="list-style-type: none"> Process variable values indicate that the value is greater than the upper sensor limit. Totalizers stop incrementing.
Downscale	Downscale	Downscale	<ul style="list-style-type: none"> Process variable values indicate that the value is lower than the lower sensor limit. Totalizers stop incrementing.
Zero	Zero	Zero	<ul style="list-style-type: none"> Flow rate variables go to the value that represents a flow rate of 0 (zero). Density is reported as 0. Temperature is reported as 0 °C, or the equivalent if other units are used (e.g., 32 °F). Drive gain is reported as measured. Totalizers stop incrementing.
Not-a-Number (NAN)	Not a Number	Not a Number	<ul style="list-style-type: none"> Process variables are reported as IEEE NAN. Drive gain is reported as measured. Modbus scaled integers are reported as Max Int. Totalizers stop incrementing.
Flow to Zero	Flow to Zero	Flow to Zero	<ul style="list-style-type: none"> Flow rates are reported as 0. Other process variables are reported as measured. Totalizers stop incrementing.
None (default)	None	None (default)	<ul style="list-style-type: none"> All process variables are reported as measured. Totalizers increment if they are running.

6.7.2 Interaction between Process Variable Fault Action and other fault actions

The setting of **Process Variable Fault Action** affects the operation of the mA Outputs, Frequency Outputs, and Discrete Outputs if the corresponding output fault actions are set to None.

Interaction between Process Variable Fault Action and mA Output Fault Action

If **mA Output Fault Action** is set to None, the mA Output signal depends on the setting of **Process Variable Fault Action**.

If the device detects a fault condition:

1. **Process Variable Fault Action** is evaluated and applied.
2. **mA Output Fault Action** is evaluated.
 - If it is set to None, the output reports the value associated with the setting of **Process Variable Fault Action**.
 - If it is set to any other option, the output performs the specified fault action.

If you want the mA Output to continue to report process data during fault conditions, you must set both **mA Output Fault Action** and **Process Variable Fault Action** to None.

Interaction between Process Variable Fault Action and Frequency Output Fault Action

If **Frequency Output Fault Action** is set to None, the Frequency Output signal depends on the setting of **Process Variable Fault Action**.

If the device detects a fault condition:

1. **Process Variable Fault Action** is evaluated and applied.
2. **Frequency Output Fault Action** is evaluated.
 - If it is set to None, the output reports the value associated with the setting of **Process Variable Fault Action**.
 - If it is set to any other option, the output performs the specified fault action.

If you want the Frequency Output to continue to report process data during fault conditions, you must set both **Frequency Output Fault Action** and **Process Variable Fault Action** to None.

Interaction between Process Variable Fault Action and Discrete Output Fault Action

If **Discrete Output Fault Action** is set to None and **Discrete Output Source** is set to Flow Rate Switch, the Discrete Output state during a fault depends on the setting of **Process Variable Fault Action**.

If the device detects a fault condition:

1. **Process Variable Fault Action** is evaluated and applied.
2. **Discrete Output Fault Action** is evaluated.
 - If it is set to None, and **Discrete Output Source** is set to Flow Rate Switch, the Discrete Output will use the value determined by the current setting of **Process Variable Fault Action** to determine if a flow rate switch has occurred.

- If **Discrete Output Source** is set to any other option, the setting of **Process Variable Fault Action** is irrelevant to the behavior of the Discrete Output during fault conditions. The Discrete Output is set to the specified fault action.

If you want the Discrete Output to report a flow rate switch appropriately during fault conditions, you must set both **Discrete Output Fault Action** and **Process Variable Fault Action** to None.

Related information

[Configure mA Output Fault Action](#)

[Configure Frequency Output Fault Action](#)

[Configure Discrete Output Fault Action](#)

7 Configure device options and preferences

7.1 Configure the transmitter display

You can control the language used on the display, the process variables shown on the display, and a variety of display behaviors.

7.1.1 Configure the language used on the display

Display	Menu → Configuration → Display Settings → Language
ProLink III	Device Tools → Configuration → Local Display Settings → Transmitter Display → General → Language
Web browser	Configuration → Transmitter Display → General → Language

Language controls the language that the display uses for process data, menus, and information.

The languages available depend on your transmitter model and version.

Procedure

Set **Language** to the desired language.

7.1.2 Configure the process variables shown on the display

Display	Menu → Configuration → Display Settings → Display Variables
ProLink III	Device Tools → Configuration → Transmitter Display → Display Variables
Web browser	Configuration → Transmitter Display → Display Variables

You can control the process variables shown on the display and the order in which they appear. The display can scroll through up to 15 process variables in any order you choose. This configuration applies to both auto-scroll and manual scrolling.

By default, one process variable is shown at a time. You can configure a custom display screen that shows two process variables at a time.

Restriction

You cannot remove all display variables. At least one display variable must be configured.

Notes

- If you have a display variable configured to show a volume process variable, and you change **Volume Flow Type** to Gas Standard Volume, the display variable is automatically changed to the equivalent GSV variable, and vice versa.
- For all other display variables, if the process variable becomes unavailable due to changes in configuration, the transmitter will not display that variable.

Procedure

For each display variable, select the process variable to be shown in that position in the rotation.

You can skip positions and you can repeat process variables.

Table 7-1: Default configuration for display variables

Display variable	Process variable assignment
Display Variable 1	Mass flow rate
Display Variable 2	Mass total
Display Variable 3	Volume flow rate
Display Variable 4	Volume total
Display Variable 5	Density
Display Variable 6	Temperature
Display Variable 7	Drive gain
Display Variable 8	None
Display Variable 9	None
Display Variable 10	None
Display Variable 11	None
Display Variable 12	None
Display Variable 13	None
Display Variable 14	None
Display Variable 15	None

7.1.3 Configure a two-line display screen

Display	Menu → Configuration → Display Settings → Display Variables → 2-Value View
ProLink III	Device Tools → Configuration → Transmitter Display → Display Variables → 2 PV Screen Slot #X
Web browser	Configuration → Transmitter Display → Display Variables → 2 PV Screen Slot #X

You can configure one display screen to show two process variables at a time. For each of these process variables, the current value and the measurement is shown.

The two-line display screen operates like one of the basic 15 screens. You can use \downarrow and \uparrow to scroll to it. If Auto Scroll is enabled, the two-line screen will be the last screen in the cycle.

7.1.4 Configure the number of decimal places (precision) shown on the display

Display	Menu → Configuration → Display Settings → Decimals on Display
ProLink III	Device Tools → Configuration → Transmitter Display → Display Variables → Decimal Places for x
Web browser	Configuration → Transmitter Display → Display Variables → Decimal Places for x

You can specify the precision (the number of decimal places) that the display uses for each display variable. You can set the precision independently for each display variable.

The display precision does not affect the actual value of the variable, the value used in calculations, or the value reported via outputs or digital communications.

Procedure

1. Select a process variable or a diagnostic variable.

You can configure the precision for all variables, whether or not they are assigned as display variables. The configured precision will be stored and used when applicable.

2. Set **Number of Decimal Places** to the number of decimal places to be used when this variable is shown on the display.
 - Default:
 - Temperature variables: 2
 - All other variables: 4
 - Range: 0 to 5

Tip

The lower the precision, the greater the change must be for it to be reflected on the display. Do not set **Number of Decimal Places** too low to be useful.

7.1.5 Turn on and turn off automatic scrolling through the display variables

Display	Menu → Configuration → Display Settings → Auto Scroll
ProLink III	Device Tools → Configuration → Transmitter Display → General → Auto Scroll
Web browser	Configuration → Transmitter Display → General → Auto Scroll

You can configure the display to automatically scroll through the list of display variables or to show a single display variable until the operator activates **Scroll**. If **Auto Scroll** is turned on, you can configure the number of seconds that each display variable will be shown.

Procedure

1. Turn on or turn off **Auto Scroll** as desired.

Option	Description
On	The display automatically shows each display variable for the number of seconds specified by Scroll Rate , then shows the next display variable. The operator can move to the next display variable at any time by activating Scroll .
Off	The display shows Display Variable 1 and does not scroll automatically. The operator can move to the next display variable at any time by activating Scroll .

Default: Off

2. If you turned on **Auto Scroll**, set **Scroll Rate** as desired.

- Default: 10
- Range: 1 to 30 seconds

Tip

Scroll Rate may not be available until you apply **Auto Scroll**.

7.1.6 Configure the display backlight

Display	Menu → Configuration → Display Settings
ProLink III	Device Tools → Configuration → Transmitter Display → General → Backlight
Web browser	Configuration → Transmitter Display → Backlight

You can control the intensity and contrast of the backlight on the display's LCD panel.

Procedure

1. Set **Intensity** as desired.
 - Default: 50
 - Range: 0 to 100
2. Set **Contrast** as desired.
 - Default: 50
 - Range: 0 to 100

7.1.7 Configure security for the display

Display	Menu → Configuration → Security → Display Security
ProLink III	Device Tools → Configuration → Transmitter Display → Display Security
Web browser	Not available

When using the display, you can require users to enter a password to do any of the following tasks:

- Enter the main menu
- Change a parameter
- Access alert data through the display
- Start, stop, or reset totalizers or inventories via the context menu

The display password can be the same or different from the totalizer/inventory context menu control password. If different, the display password is used to reset, start, and stop totalizers or inventories using **Menu → Operations → Totalizers**.

Procedure

1. Configure **Password Required** as desired.

Option	Description
At Write	When an user chooses an action that leads to a configuration change, they are prompted to enter the display password.
Enter Menu	When the menu is selected from the process variable screen, the display password will be immediately required if Password Required is set.
Never (default)	When a user chooses an action that leads to a configuration change, they are prompted to activate $\Rightarrow \uparrow \downarrow \Leftarrow$. This is designed to protect against accidental changes to configuration. It is not a security measure.

2. If the At Write or Enter Menu option was selected, enable or disable alert security as desired.

Option	Description
Enabled	If an alert is active, the alert symbol ⓘ is shown in the upper right corner of the display but the alert banner is not displayed. If the operator attempts to enter the alert menu, they are prompted to enter the display password.
Disabled	If an alert is active, the alert symbol ⓘ is shown in the upper right corner of the display and the alert banner is displayed automatically. No password or confirmation is required to enter the alert menu.

Restriction

You cannot set **Password Required** to Never and enable alert security.

- If you did not enable **Password Required**, alert security is disabled and cannot be enabled.
- Alert security is disabled automatically if you set **Password Required** to Never after:
 - **Password Required** is initially set to either At Write or Enter Menu
 - Alert security is enabled

3. If **Password Required** has been set to At Write or Enter Menu, you will be prompted to enter the desired password.
 - Default: AAAA
 - Range: Any four alphanumeric characters
 - **Password Required** must be set to At Write or Enter Menu to enable the totalizer/inventory control context menu password option.

Important

If you enable **Password Required** but you do not change the display password, the transmitter will post a configuration alert.

4. Configure **Main Menu Available** as desired.

Option	Description
Enabled	The local display Menu option from the process variable screen will be accessible.
Disabled	The local display Menu option from the process variable screen will not be accessible.

Important

Once **Main Menu Available** has been disabled, you cannot enable it from the local display. Use another configuration tool, such as ProLink III, to re-enable main menu access from the local display.

7.1.8 Configure totalizer and inventory control

Display	Menu → Configuration → Security → Display Security → Totalizers & Inventories
ProLink III	Device Tools → Configuration → Totalizer Control Methods
Web browser	Configuration → Security → Totalization Control Methods

You can enable or disable the operator's ability to start, stop, or reset totalizers or inventories. The totalizer/inventory control context menus password can also be configured. The context menu is accessed by selecting the options menu from the process variable screen when a total or inventory is displayed.

These parameters do not affect the operator's ability to start, stop, or reset totalizers or inventories using another tool.

Procedure

1. Enable or disable **Reset Totalizers**, as desired.
Default = Enable
2. Enable or disable **Start/Stop Totalizers**, as desired.
Default = Enable
3. Enable or disable **Reset Inventory**, as desired.
Default = Disable
4. Enable or disable **Start/Stop Inventory**, as desired.
Default = Disable
5. If required, configure the totalizer/inventory control context menu password.

Option	Description
No password (default)	Start, stop or reset totalizer/inventory actions via the context menu do not require a password.
Password Required	When a user selects Start/Stop or Reset from the context menu and the password is enabled for totalizer/inventory control, the user is required to enter a password before the action occurs.

If the context menu password option has been set to **Password Required**, you will be prompted to enter the password.

- Default: AAAA
- Range: Any four alphanumeric characters
- The display **Password Required** must be set to At Write or Enter Menu to enable the totalizer/inventory control context menu password option.

Important

If you enable **Password Required** for totalizers and inventories, but you do not change the password from the default, the transmitter will post a configuration alert.

7.2 Configure the transmitter's response to alerts

7.2.1 Configure the transmitter's response to alerts using the display

For some alerts, you can change the transmitter's response to an alert by setting the alert severity. You can also configure the transmitter to ignore some alerts and conditions.

The transmitter implements the NAMUR NE 107 specification for alerts. NAMUR NE 107 categorizes alerts by the suggested operator action, not by cause or symptom. Each alert has one or more associated conditions.

Important

The transmitter reports all the process and device conditions that were reported by previous transmitters. However, the transmitter does not report them as individual alerts. Instead, the transmitter reports them as conditions associated with alerts.

Procedure

- To change the severity of an alert:
 - a) Choose **Menu** → **Configuration** → **Alert Setup** → **Response to Alerts**.
 - b) Select the alert.
 - c) Set **Alert Severity** as desired.

Option	Description
Failure	The event is serious enough to require fault actions by the transmitter. The event may be either device-related or process-related. Operator action is strongly recommended.
Function Check	Configuration change or device testing. No fault actions are performed. The operator may need to complete a procedure.
Out of Specification	The process is outside user-specified limits or device limits. No fault actions are performed. The operator should check the process.
Maintenance Required	Device maintenance is recommended, either near-term or mid-term.

- To ignore an alert:
 - a) Choose **Menu** → **Configuration** → **Alert Setup** → **Response to Alerts**
 - b) Select the alert.
 - c) Set **Alert Detection** to Ignore.

If an alert is ignored, any occurrence of this alert is not posted to the alert list and the status LED on the transmitter does not change color. The occurrence is posted to alert history.

- To ignore a condition:
 - a) Choose **Menu** → **Configuration** → **Alert Setup** → **Response to Alerts**
 - b) Select the alert associated with the condition.
 - c) Select Condition Detection.
 - d) Select the condition and set it to Ignore.

If a condition is ignored, any occurrence of this condition is not posted to the alert list and the status LED on the transmitter does not change color. The occurrence is posted to alert history.

7.2.2 Configure the transmitter's response to alerts using ProLink III

For some alerts, you can change the transmitter's response to an alert by setting the alert severity. You can also configure the transmitter to ignore some alerts and conditions.

The transmitter implements the NAMUR NE 107 specification for alerts. NAMUR NE 107 categorizes alerts by the suggested operator action, not by cause or symptom. Each alert has one or more associated conditions.

Important

The transmitter reports all the process and device conditions that were reported by previous transmitters. However, the transmitter does not report them as individual alerts. Instead, the transmitter reports them as conditions associated with alerts.

Procedure

- To change the severity of an alert:
 - a) Choose **Device Tools** → **Configuration** → **Alert Severity**.
 - b) Select the alert.
 - c) Set the severity as desired.

Option	Description
Failure	The event is serious enough to require fault actions by the transmitter. The event may be either device-related or process-related. Operator action is strongly recommended.
Function Check	Configuration change or device testing. No fault actions are performed. The operator may need to complete a procedure.
Out of Specification	The process is outside user-specified limits or device limits. No fault actions are performed. The operator should check the process.
Maintenance Required	Device maintenance is recommended, either near-term or mid-term.

- To ignore an alert:
 - a) Choose **Device Tools** → **Configuration** → **Alert Severity**.
 - b) Select the alert.
 - c) Set the severity to Ignore.

If an alert is ignored, any occurrence of this alert is not posted to the alert list and the status LED on the transmitter does not change color. The occurrence is posted to alert history.

- To ignore a condition:
 - a) Choose **Menu** → **Configuration** → **Alert Setup** → **Response to Alerts**.
 - b) Select the alert associated with the condition and expand it.
 - c) Select the condition and set it to Ignore.

If a condition is ignored, any occurrence of this condition is not posted to the alert list and the status LED on the transmitter does not change color. The occurrence is posted to alert history.

7.2.3 Configure Fault Timeout

Display	Menu → Configuration → Alert Setup → Output Fault Actions → Fault Timeout (sec)
ProLink III	Device Tools → Configuration → Fault Processing → Fault Timeout
Web browser	Configuration → Alert Setup → Output Fault Actions → Fault Timeout

Fault Timeout controls the delay before fault actions are performed.

The fault timeout period begins when the transmitter detects an alert condition.

- During the fault timeout period, the transmitter continues to report its last valid measurements.
- If the fault timeout period expires while the alert is still active, the fault actions are performed.
- If the alert condition clears before the fault timeout expires, no fault actions are performed.

Restriction

- **Fault Timeout** is not applied to all alerts. For some alerts, fault actions are performed as soon as the alert condition is detected. See the list of alerts and conditions for details.
- **Fault Timeout** is applicable only when **Alert Severity** = Failure. For all other settings of **Alert Severity**, **Fault Timeout** is irrelevant.

Procedure

Set **Fault Timeout** as desired.

- Default: 0 seconds
- Range: 0 to 60 seconds

If you set **Fault Timeout** to 0, fault actions are performed as soon as the alert condition is detected.

7.2.4 Alerts, conditions, and configuration options

For more information on these alerts, see [Status alerts, causes, and recommendations](#).

Configuration Error

Default severity: Failure
Severity configurable: No
Fault Timeout applicable: No

Table 7-2: Configuration Error conditions

Name	Ignorable
[020] Calibration Factors Missing	No
[021] Incorrect Sensor Type	Yes
[030] Incorrect Board Type	No
Core Processor Update Failed	Yes
Password Not Set	No
Time Not Entered	Yes
Batcher Not Configured	Yes
[120] Curve Fit Failure (Concentration)	No
Bad IP network settings	No

Core Low Power

Default severity: Failure
Severity configurable: No
Fault Timeout applicable: No

Table 7-3: Core Low Power conditions

Name	Ignorable
[031] Low Power	No

Configuration Warning

Default severity: Maintenance Required
Severity configurable: Yes
Fault Timeout applicable: No

Table 7-4: Configuration Warning conditions

Name	Ignorable
[103] Configuration Warning	Yes
SD Card Failure	No
No Permanent License	No
Clock Failure	No

Table 7-4: Configuration Warning conditions (continued)

Name	Ignorable
SD Card Full	No
Transmitter Software Update Failed	Yes

Drive Over Range

Default severity: Maintenance

Severity configurable: Yes

Fault Timeout applicable: Yes

Table 7-5: Drive Over-Range conditions

Name	Ignorable
[102] Drive Overrange	Yes

Electronics Failed

Default severity: Failure

Severity configurable: No

Fault Timeout applicable: No

Table 7-6: Electronics Failed conditions

Name	Ignorable
[002] RAM Error (Core Processor)	No
[018] EEPROM Error (Transmitter)	No
[019] RAM Error (Transmitter)	No
[022] Configuration Database Corrupt (Core Processor)	No
[024] Program Corrupt (Core Processor)	No
Watchdog Error	No

Event Active

Default severity: Out of Speculation

Severity configurable: Yes

Fault Timeout applicable: Yes

Table 7-7: Event Active conditions

Name	Ignorable
Enhanced Event [1 - 5] Active	Yes
Event [1 - 2] Active	Yes

Extreme Primary Purpose Variable

Default severity: Failure

Severity configurable: Yes

Fault Timeout applicable: Yes

Table 7-8: Extreme Primary Purpose Variable conditions

Name	Ignorable
[005] Mass Flow Rate Overrange	No
[008] Density Overrange	No

Function Check Failed or Smart Meter Verification Aborted

Default severity: Maintenance Required

Severity configurable: Yes

Fault Timeout applicable: No

Table 7-9: Function Check Failed or Smart Meter Verification Aborted conditions

Name	Ignorable
[010] Calibration Failed	No
[034] Smart Meter Verification Failed	Yes
[035] Smart Meter Verification Aborted	Yes

Function Check in Progress

Default severity: Function Check

Severity configurable: No

Fault Timeout applicable: No

Table 7-10: Function Check in Progress conditions

Name	Ignorable
[104] Calibration in Progress	No
[131] Smart Meter Verification in Progress	Yes

Output Fixed

Default severity: Function Check

Severity configurable: Yes

Fault Timeout applicable: No

Table 7-11: Output Fixed conditions

Name	Ignorable
[111] Frequency Output 1 Fixed	No
[119] Discrete Output 2 Fixed	No
mA Output 2 Fixed	No

Output Saturated

Default severity: Out of Speculation
Severity configurable: Yes
Fault Timeout applicable: No

Table 7-12: Output Saturated conditions

Name	Ignorable
[110] Frequency Output 1 Saturated	Yes
mA Output 3 Saturated	Yes

Process Aberration

Default severity: Out of Speculation
Severity configurable: Yes
Fault Timeout applicable: Yes

Table 7-13: Process Aberration conditions

Name	Ignorable
[105] Two-Phase Flow	Yes
[116] Temperature Overrange (API Referral)	Yes
[117] Density Overrange (API Referral)	Yes
[121] Extrapolation Alert (Concentration)	Yes
[123] Pressure Overrange (API Referral)	Yes
[138] TBR Active	Yes
Batch Time Out	Yes
Moderate Two-Phase Flow	Yes
Severe Two-Phase Flow	Yes

Security Breach

Default severity: Failure
Severity configurable: No
Fault Timeout applicable: No

Table 7-14: Security Breach conditions

Name	Ignorable
[027] Security Breach	No

Sensor Being Simulated

Default severity: Function Check
Severity configurable: No
Fault Timeout applicable: No

Table 7-15: Sensor Being Simulated conditions

Name	Ignorable
[132] Sensor Simulation Active	No

Sensor Failed

Default severity: Failure

Severity configurable: No

Fault Timeout applicable: Yes

Table 7-16: Sensor Failed conditions

Name	Ignorable
[003] Sensor Failed	No
[016] Sensor Temperature (RTD) Failure	No
[017] Sensor Case Temperature (RTD) Failure	No

Sensor-Transmitter Communication Error

Default severity: Failure

Severity configurable: No

Fault Timeout applicable: Yes

Table 7-17: Sensor-Transmitter Communication Error conditions

Name	Ignorable
[026] Sensor/Transmitter Communications Failure	No
[028] Core Process Write Failure	No

Transmitter Initializing

Default severity: Failure

Severity configurable: No

Fault Timeout applicable: No

Table 7-18: Transmitter Initializing conditions

Name	Ignorable
[009] Transmitter Initializing/Warming Up	No

Tube Not Full

Default severity: Failure

Severity configurable: Yes

Fault Timeout applicable: Yes

Table 7-19: Tube Not Full conditions

Name	Ignorable
[033] Insufficient Pickoff Signal	Yes

7.3 Control button sensitivity on the display

Display	Menu → Configuration → Yes → Display Settings → Button Sensitivity
---------	--

You can configure the button sensitivity for each button (right, left, up, down) from the 200 default level to a range of 187 to 225, where the lower number signifies lower sensitivity.

8 Integrate the meter with the control system

8.1 Channel configuration

Display	Menu → Configuration → Inputs/Outputs → Channel x
ProLink III	Device Tools → Configuration → I/O → Channels → Channel x
Web browser	Configuration → Inputs/Outputs → Channel x

8.2 Configure Ethernet Channel A and Channel B

Channel A and Channel B are exclusively used for Ethernet communication. Each channel can have individually different settings related to network negotiation and crossover cabling.

Procedure

Set **Auto Negotiate** to the desired value.

- **Enabled** (default): The channel will automatically communicate with the network at the highest transmission mode supported by both the transmitter and the network. This is usually the correct choice.
- **Disabled**: The channel will only communicate using defined speed and duplex settings. This may be necessary on a network with older devices that cannot automatically negotiate. After you select **Disabled**, you can verify or change the speed and duplex settings to match the settings required on your network:
 - **Speed**: 10 Mbps or 100 Mbps
 - **Duplex**: Half Duplex or Full Duplex

8.3 Configure I/O Channel C

Channel C is a configurable I/O channel.

Channel C can be used for any of the following inputs or outputs:

- mA Output
- Frequency Output
- Discrete Output
- Discrete Input

Prerequisites

Important

To avoid causing process errors:

- The channel configuration must match the I/O wiring.

- Before changing the channel configuration, ensure that all control loops affected by the channel are under manual control.

Procedure

1. Set **Channel Type** as desired.
2. Set **Power Source** as desired.

Option	Description
Internal (Active)	The channel is powered by the transmitter.
External (Passive)	The channel is powered by an external power source.

Postrequisites

Perform or verify the corresponding output or input configuration. When the configuration of a channel is changed, the channel's behavior will be controlled by the configuration that is stored for the selected input or output type, and the stored configuration may not be appropriate for your process.

After verifying channel and output configuration, return the control loop to automatic control.

8.4 Configure an mA Output

Use an mA Output to report current values of process variables. The mA signal varies between 4 mA and 20 mA in proportion to the current value of the assigned process variable.

Depending on your purchase order and channel configuration, your transmitter may have 0–3 mA Outputs. Channel A is always mA Output 1, and Channel B and Channel C can be configured as mA Output 2 and mA Output 3 respectively.

8.4.1 Configure mA Output Source

Display	Menu → Configuration → Inputs/Outputs → Channel C → I/O Settings → Source
ProLink III	Device Tools → Configuration → I/O → Channels → Channel C → mA Output
Web browser	Configuration → Inputs/Outputs → Channel C → Channel Type → mA Output

mA Output Source specifies the process variable that is reported by the mA Output.

Prerequisites

- If you plan to configure the output to report volume flow, ensure that you have set **Volume Flow Type** as desired: Liquid or Gas Standard Volume.
- If you plan to configure an output to report a concentration measurement process variable, API Referral, or Advance Phase Measurement process variable, ensure that the concentration measurement application, API Referral, or Advance Phase Measurement application respectively, is configured so that the desired variable is available.

Procedure

Set **mA Output Process Variable** as desired.

Default: mA Output 1: Mass Flow Rate

Postrequisites

If you change the configuration of **mA Output Source**, verify the settings of **Lower Range Value** and **Upper Range Value**. The transmitter automatically loads a set of values, and these values may not be appropriate for your application.

Options for mA Output Source

The transmitter provides a basic set of options for **mA Output Source**, plus several application-specific options. Different communications tools may use different labels for the options.

Process variable	Label		
	Display	ProLink III	Web browser
Standard			
Mass flow rate	Mass Flow Rate	Mass Flow Rate	Mass Flow Rate
Volume flow rate	Volume Flow Rate	Volume Flow Rate	Volume Flow Rate
Gas standard volume flow rate	GSV Flow Rate	Gas Standard Volume Flow Rate	Gas Standard Volume Flow Rate
Temperature	Temperature	Temperature	Temperature
Density	Density	Density	Density
External pressure	External Pressure	External Pressure	External pressure
External temperature	External Temperature	External Temperature	External temperature
Diagnostics			
Velocity	Velocity	Velocity	Approximate Velocity
Two-phase flow detection	Phase	Phase Flow Severity	Phase Genius
Drive gain	Drive Gain	Drive Gain	Drive Gain
API Referral			
Temperature-corrected density	Referred Density	Density at Reference Temperature	Density at Reference Temperature
Temperature-corrected (standard) volume flow rate	Referred Volume Flow	Volume Flow Rate at Reference Temperature	Referred Volume Flow Rate
Average temperature-corrected density	Average Line Density	Average Density	Average Observed Density
Average temperature	Average Temperature	Average Temperature	Average Temperature
Concentration measurement			
Density at reference	Referred Density	Density at Reference Temperature	Dens at Ref (CM)
Specific gravity	Specific Gravity	Density (Fixed SG Units)	Spec Gravity (CM)
Standard volume flow rate	Standard Vol Flow	Volume Flow Rate at Reference Temperature	Standard Volume Flow Rate
Net mass flow rate	Net Mass Flow	Net Mass Flow Rate	Net Mass Flow (CM)

Process variable	Label		
	Display	ProLink III	Web browser
Net volume flow rate	Net Volume Flow Rate	Net Volume Flow Rate	Net Volume Flow Rate (CM)
Concentration	Concentration	Concentration	Concentration (CM)
Baume	Baume	Baume	Baume (CM)
Batching			
% of batch delivered	% of Fill	% of Fill Delivered	% of Fill Delivered

8.4.2 Configure Lower Range Value (LRV) and Upper Range Value (URV) for the mA Output

Display	Menu → Configuration → Inputs/Outputs → Channel C → I/O Settings → Lower Range Value Menu → Configuration → Inputs/Outputs → Channel C → I/O Settings → Upper Range Value
ProLink III	Device Tools → Configuration → I/O → Outputs → mA Output → Lower Range Value Device Tools → Configuration → I/O → Outputs → mA Output → Upper Range Value
Web browser	Configuration → Inputs/Outputs → Channel C → mA Output → Lower Range Value Configuration → Inputs/Outputs → Channel C → mA Output → Upper Range Value

The **Lower Range Value (LRV)** and **Upper Range Value (URV)** are used to scale the mA Output, that is, to define the relationship between **mA Output Process Variable** and the mA Output signal.

LRV is the value of **mA Output Source** represented by an output of 4 mA. **URV** is the value of **mA Output Source** represented by an output of 20 mA. Between **LRV** and **URV**, the mA Output is linear with the process variable. If the process variable drops below **LRV** or rises above **URV**, the transmitter posts an output saturation alert.

Procedure

Set **LRV** and **URV** as desired.

Enter **LRV** and **URV** in the measurement units used for **mA Output Source**.

- Defaults: Specific to each process variable
- Range: Unlimited

Note

You can set **URV** below **LRV**. For example, you can set **URV** to 50 and **LRV** to 100. If you do this, the mA Output will be inversely proportional to the value of **mA Output Source**.

8.4.3 Configure mA Output Direction

Display	Menu → Configuration → Inputs/Outputs → Channel C → I/O Settings → Direction
ProLink III	Device Tools → Configuration → I/O → Outputs → mA Output → Direction
Web browser	Configuration → Inputs/Outputs → Channel C → mA Output → Direction

mA Output Direction controls how conditions of forward flow and reverse flow affect the flow rates reported by the mA Output.

Actual flow direction interacts with **Sensor Flow Direction Arrow** to determine the flow direction that the transmitter uses in processing. See the following table.

Table 8-1: Interaction between actual flow direction and Sensor Flow Direction Arrow

Actual flow direction	Setting of Sensor Flow Direction Arrow	Flow direction sent to outputs and totalizers
Forward (same direction as Flow arrow on sensor)	With Arrow	Forward
	Against Arrow	Reverse
Reverse (opposite from Flow arrow on sensor)	With Arrow	Reverse
	Against Arrow	Forward

Procedure

Set **mA Output Direction** as desired.

Option	Description
Normal (default)	Appropriate when your application needs to distinguish between forward flow and reverse flow.
Absolute Value	Appropriate when your application does not need to distinguish between forward flow and reverse flow.

Important

mA Output Direction interacts with **Lower Range Value (LRV)**. The effect of **mA Output Direction** on the mA Output varies, depending on whether $LRV < 0$ or $LRV \geq 0$.

Related information

[Configure Sensor Flow Direction Arrow](#)

Effect of mA Output Direction on an mA Output

mA Output Direction affects how the transmitter reports flow values via an mA Output. An mA Output is affected by **mA Output Direction** only if **mA Output Source** is set to a flow variable.

The effect of **mA Output Direction** depends on the setting of **Lower Range Value (LRV)**.

- If **Lower Range Value** = 0, see [Figure 8-1](#).
- If **Lower Range Value** > 0, see [Figure 8-1](#) and adapt the chart.
- If **Lower Range Value** < 0, see [Figure 8-2](#).

Figure 8-1: Effect of mA Output Direction on an mA Output: Lower Range Value = 0

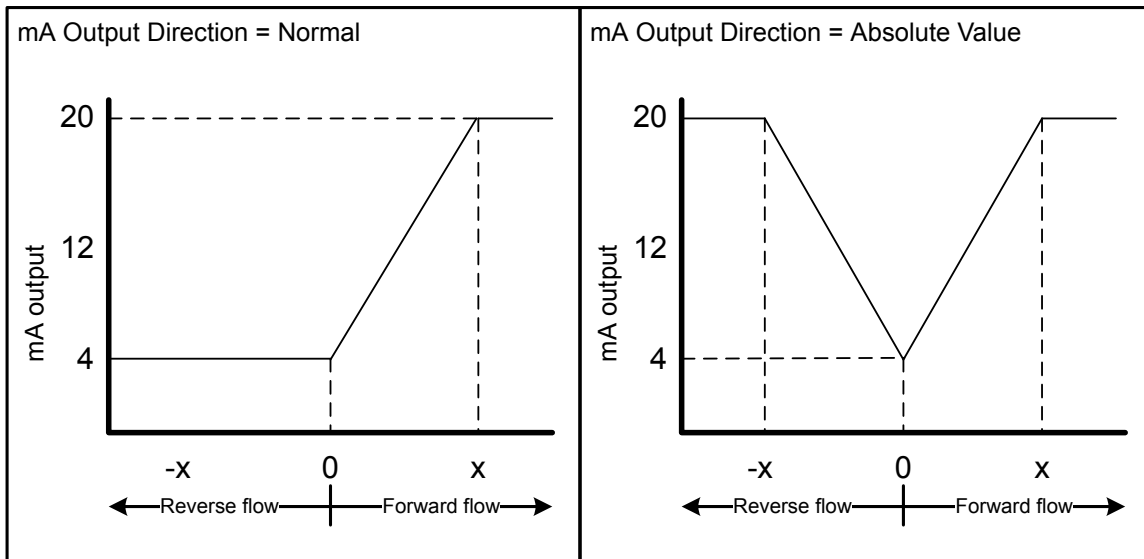

- Lower Range Value = 0
- Upper Range Value = x

Figure 8-2: Effect of mA Output Direction on an mA Output: Lower Range Value < 0

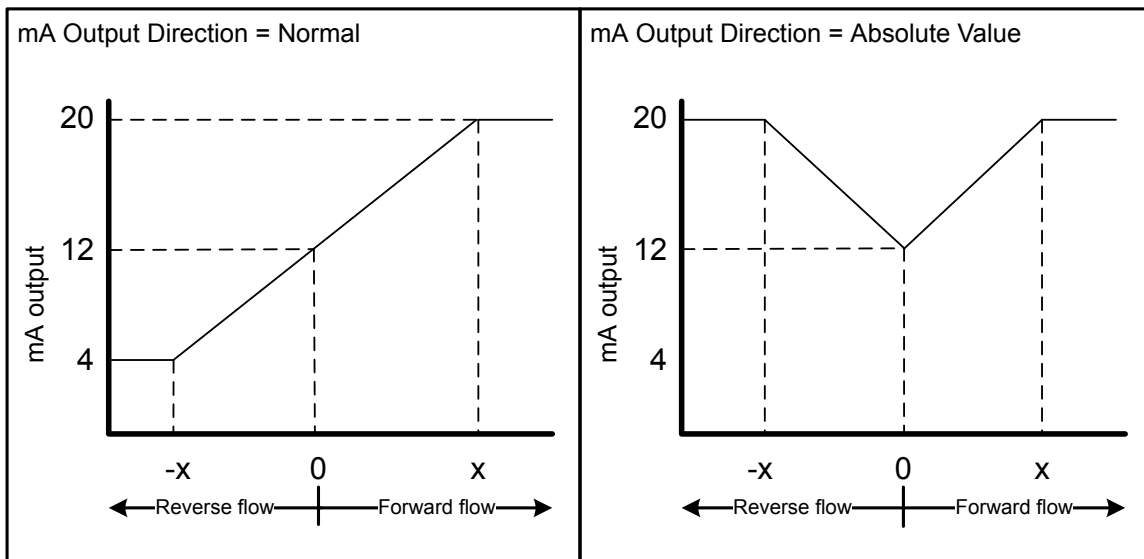

- Lower Range Value = -x
- Upper Range Value = x

Example: mA Output Direction = Normal and Lower Range Value = 0

Configuration:

- **mA Output Direction** = Normal
- **Lower Range Value** = 0 g/sec
- **Upper Range Value** = 100 g/sec

Result:

- Under conditions of reverse flow or zero flow, the mA Output is 4 mA.
- Under conditions of forward flow, up to a flow rate of 100 g/sec, the mA Output varies between 4 mA and 20 mA in proportion to the flow rate.
- Under conditions of forward flow, if the flow rate equals or exceeds 100 g/sec, the mA Output will be proportional to the flow rate up to 20.5 mA, and will be level at 20.5 mA at higher flow rates.

Example: mA Output Direction = Normal and Lower Range Value < 0

Configuration:

- **mA Output Direction** = Normal
- **Lower Range Value** = -100 g/sec
- **Upper Range Value** = +100 g/sec

Result:

- Under conditions of zero flow, the mA Output is 12 mA.
- Under conditions of forward flow, for flow rates between 0 and +100 g/sec, the mA Output varies between 12 mA and 20 mA in proportion to (the absolute value of) the flow rate.
- Under conditions of forward flow, if (the absolute value of) the flow rate equals or exceeds 100 g/sec, the mA Output is proportional to the flow rate up to 20.5 mA, and will be level at 20.5 mA at higher flow rates.
- Under conditions of reverse flow, for flow rates between 0 and -100 g/sec, the mA Output varies between 4 mA and 12 mA in inverse proportion to the absolute value of the flow rate.
- Under conditions of reverse flow, if the absolute value of the flow rate equals or exceeds 100 g/sec, the mA Output is inversely proportional to the flow rate down to 3.8 mA, and will be level at 3.8 mA at higher absolute values.

8.4.4 Configure mA Output Cutoff

Display	Menu → Configuration → Inputs/Outputs → Channel C → I/O Settings → MAO Cutoff
ProLink III	Device Tools → Configuration → I/O → Outputs → mA Output x → Flow Rate Cutoff
Web browser	Configuration → Inputs/Outputs → Channel C → mA Output → Flow Rate Cutoff

mA Output Cutoff specifies the lowest flow rate that will be reported through the mA Output. All flow rates below the specified value are reported as 0.

mA Output Cutoff is applicable only when **mA Output Source** is set to a flow rate variable. It is applied to whatever flow variable is assigned to the mA Output.

Procedure

Set **mA Output Cutoff** as desired.

Set **mA Output Cutoff** in the measurement units used for the process variable. If you change the measurement unit, **mA Output Cutoff** is adjusted automatically.

- Default: 0
- Range: 0 or any positive value

Tip

For most applications the default value of **mA Output Cutoff** should be used. Contact customer service before changing **mA Output Cutoff**.

Interaction between mA Output Cutoff and process variable cutoffs

When **mA Output Process Variable** is set to a flow variable (for example, mass flow rate or volume flow rate), **mA Output Cutoff** interacts with **Mass Flow Cutoff** or **Volume Flow Cutoff**. The transmitter puts the cutoff into effect at the highest flow rate at which a cutoff is applicable.

8.4.5 Configure mA Output Damping

Display	Menu → Configuration → Inputs/Outputs → Channel C → I/O Settings → MAO Damping
ProLink III	Device Tools → Configuration → I/O → Outputs → mA Output → Added Damping
Web browser	Configuration → Inputs/Outputs → Channel C → mA Output → Added Damping

mA Output Damping controls the amount of damping that will be applied to the mA Output.

Damping is used to smooth out small, rapid fluctuations in process measurement. The damping value specifies the time period, in seconds, over which the transmitter will spread changes in the process variable. At the end of the interval, the value reported by the mA Output will reflect 63% of the change in the actual measured value.

mA Output Damping affects a process variable only when it is reported via the mA Output. If the process variable is read from the display or digitally, **mA Output Damping** is not applied.

Procedure

Set **mA Output Damping** to the desired value.

- Default: 0.0 seconds
- Range: 0.0 to 440 seconds

Tip

- A high damping value makes the process variable appear smoother because the reported value changes slowly.
- A low damping value makes the process variable appear more erratic because the reported value changes more quickly.
- The combination of a high damping value and rapid, large changes in the process variable assigned to the mA Output can result in increased measurement error.

- Whenever the damping value is non-zero, the damped value will lag the actual measurement because the damped value is being averaged over time.
- In general, lower damping values are preferable because there is less chance of data loss, and less lag time between the actual measurement and the damped value.

Interaction between mA Output Damping and process variable damping

When **mA Output Source** is set to a flow rate variable, density, or temperature, **mA Output Damping** interacts with **Flow Damping**, **Density Damping**, or **Temperature Damping**. If multiple damping parameters are applicable, the effect of damping the process variable is calculated first, and the mA Output damping calculation is applied to the result of that calculation.

Example: Damping interaction

Configuration:

- **Flow Damping** = 1 second
- **mA Output Source** = Mass Flow Rate
- **mA Output Damping** = 2 seconds

Result: A change in the mass flow rate will be reflected in the mA Output over a time period that is greater than 3 seconds. The exact time period is calculated by the transmitter according to internal algorithms which are not configurable.

8.4.6 Configure mA Output Fault Action

Display	Menu → Configuration → Inputs/Outputs → Channel C → I/O Settings → Fault Action
ProLink III	Device Tools → Configuration → I/O → Outputs → mA Output x → Fault Action
Web browser	Configuration → Inputs/Outputs → Channel C → mA Output → Fault Action

mA Output Fault Action controls the behavior of the mA Output if the transmitter detects a fault condition.

Important

- The fault action is implemented only if **Alert Severity** is set to Failure. If **Alert Severity** is set to any other option, the fault action is not implemented.
- For some faults only: If **Fault Timeout** is set to a non-zero value, the transmitter will not implement the fault action until the timeout has elapsed.

Procedure

1. Set **mA Output Fault Action** as desired.

Default: Downscale

Important

If you set **mA Output Fault Action** to None, the mA Output will be controlled by the setting of **Process Variable Fault Action**. In most cases, if you set **mA Output Fault Action** to None, you should also set **Process Variable Fault Action** to None.

- If you set **mA Output Fault Action** to **Upscale** or **Downscale**, set **mA Output Fault Level** to the signal that the mA Output will produce during a fault.

Related information

[Configure Process Variable Fault Action](#)

[Interaction between Process Variable Fault Action and other fault actions](#)

Options for mA Output Fault Action and mA Output Fault Level

Option	mA Output behavior	mA Output Fault Level
Upscale	Goes to the configured fault level	Default: 22.0 mA Range: 21.0 to 23.0 mA
Downscale (default)	Goes to the configured fault level	Default: 2.0 mA Range: 1.0 to 3.6 mA
Internal Zero	Goes to the mA Output level associated with a process variable value of 0 (zero), as determined by Lower Range Value and Upper Range Value settings	Not applicable
None	Determined by the setting of Process Variable Fault Action	Not applicable

8.5 Configure a Frequency Output

Use a Frequency Output to report current values of process variables. The frequency varies between 0 Hz and 14500 Hz in proportion to the current value of the assigned process variable.

8.5.1 Configure Frequency Output Source

Display	Menu → Configuration → Inputs/Outputs → Channel C → I/O Type → Frequency Output
ProLink III	
Web browser	Configuration → Inputs/Outputs → Channel C → Frequency Output

Frequency Output Source specifies the process variable that is reported by the Frequency Output.

Prerequisites

- If you plan to configure the output to report volume flow, ensure that you have set **Volume Flow Type** as desired: Liquid or Gas Standard Volume.
- If you plan to configure an output to report a concentration measurement process variable, ensure that the concentration measurement application is configured so that the desired variable is available.

Procedure

Set **Frequency Output Source** as desired.

Default: Frequency Output 1: Mass Flow Rate

Postrequisites

If you change the configuration of **Frequency Output Source**, verify the Frequency Output scaling. The transmitter automatically loads the most recent values for the scaling parameters, and they may not be appropriate for your application.

Related information

[Configure Frequency Output Scaling](#)

Options for Frequency Output Source

The transmitter provides a basic set of options for **Frequency Output Source**, plus several application-specific options. Different communications tools may use different labels for the options.

Process variable	Label		
	Display	PLIII	Web browser
Standard			
Mass flow rate	Mass Flow Rate	Mass Flow Rate	Mass Flow Rate
Volume flow rate	Volume Flow Rate	Volume Flow Rate	Volume Flow Rate
Gas standard volume flow rate	GSV Flow Rate	Gas Standard Volume Flow Rate	GSV Flow Rate
API Referral			
Temperature-corrected (standard) volume flow rate	Referred Volume Flow	Volume Flow Rate at Reference Temperature	Referred Volume Flow Rate
Concentration measurement			
Standard volume flow rate	Standard Vol Flow	Volume Flow Rate at Reference Temperature	Standard Volume Flow Rate
Net mass flow rate	Net Mass Flow	Net Mass Flow Rate	Net Mass Flow (CM)
Net volume flow rate	Net Volume Flow Rate	Net Volume Flow Rate	Net Volume Flow Rate (CM)

8.5.2 Configure Frequency Output Scaling

Display	Menu → Configuration → Inputs/Outputs → Channel C → I/O Settings → Scaling Method
ProLink III	Device Tools → Configuration → I/O → Outputs → Frequency Output → Scaling Method
Web browser	Configuration → Inputs/Outputs → Channel C → Frequency Output → Scaling Method

Frequency output scaling defines the relationship between **Frequency Output Source** and the pulse of the Frequency Output. Scale the Frequency Output to provide the data in the form required by your frequency receiving device.

Procedure

1. Set **Frequency Output Scaling Method**.

Option	Description
Frequency=Flow (default)	Frequency calculated from flow rate
Pulses/Unit	A user-specified number of pulses represents one flow unit
Units/Pulse	A pulse represents a user-specified number of flow units

2. Set additional required parameters.

- If you set **Frequency Output Scaling Method** to Frequency=Flow, set **Rate Factor** and **Frequency Factor**.
- If you set **Frequency Output Scaling Method** to Pulses/Unit, define the number of pulses that will represent one flow unit.
- If you set **Frequency Output Scaling Method** to Units/Pulse, define the number of units that each pulse will indicate.

Calculate frequency from flow rate

The Frequency=Flow option is used to customize the Frequency Output for your application when you do not know appropriate values for Units/Pulse or Pulses/Unit.

If you specify Frequency=Flow, you must provide values for **Rate Factor** and **Frequency Factor**:

Rate Factor The maximum flow rate that you want the Frequency Output to report.

Frequency Factor A value calculated as follows:

$$FrequencyFactor = \frac{RateFactor}{T} \times N$$

where:

T Factor to convert selected time base to seconds

N Number of pulses per flow unit, as configured in the receiving device

The resulting **Frequency Factor** must be within the range of the Frequency Output :

- If **Frequency Factor** is less than 1 Hz, reconfigure the receiving device for a higher pulses/unit setting.

Example: Configure Frequency=Flow

You want the Frequency Output to report all flow rates up to 2000 kg/min.

The frequency receiving device is configured for 10 pulses/kg.

Solution:

$$FrequencyFactor \frac{RateFactor}{T} \times N$$

$$FrequencyFactor \frac{2000}{60} \times 10$$

$$FrequencyFactor = 333.33$$

Set parameters as follows:

- **Rate Factor:** 2000
- **Frequency Factor:** 333.33

8.5.3 Configure Frequency Output Direction

Display	Menu → Configuration → Inputs/Outputs → Channel x → I/O Settings → Direction
ProLink III	Device Tools → Configuration → I/O → Outputs → Frequency Output → Direction
Web browser	Configuration → Inputs/Outputs → Channel C → Frequency Output → Direction

Frequency Output Direction controls how conditions of forward flow and reverse flow affect the flow rates reported by the Frequency Output.

Actual flow direction interacts with **Sensor Flow Direction Arrow** to determine the flow direction that the transmitter uses in processing. See the following table.

Table 8-2: Interaction between actual flow direction and Sensor Flow Direction Arrow

Actual flow direction	Setting of Sensor Flow Direction Arrow	Flow direction sent to outputs and totalizers
Forward (same direction as Flow arrow on sensor)	With Arrow	Forward
	Against Arrow	Reverse
Reverse (opposite from Flow arrow on sensor)	With Arrow	Reverse
	Against Arrow	Forward

Procedure

Set **Frequency Output Direction** as desired.

Option	Description
Positive Flow Only	<ul style="list-style-type: none"> • Forward flow: The Frequency Output reports the flow rate according to the configured scaling method. • Reverse flow: The Frequency Output is 0 Hz.

Option	Description
Negative Flow Only	<ul style="list-style-type: none"> Forward flow: The Frequency Output is 0 Hz. Reverse flow: The Frequency Output reports the absolute value of the flow rate according to the configured scaling method.
Both Positive and Negative Flow	The Frequency Output reports the absolute value of the flow rate according to the configured scaling method. It is not possible to distinguish between forward flow and reverse flow from the Frequency Output alone. This setting is typically used in combination with a discrete output configured to report flow direction.

Related information

[Configure Sensor Flow Direction Arrow](#)

[Configure Discrete Output Source](#)

8.5.4 Configure Frequency Output Fault Action

Display	Menu → Configuration → Inputs/Outputs → Channel C → I/O Settings → Fault Action
ProLink III	Device Tools → Configuration → I/O → Outputs → Frequency Output x → Fault Action
Web browser	Configuration → Inputs/Outputs → Channel C → Frequency Output → Fault Action

Frequency Output Fault Action controls the behavior of the Frequency Output if the transmitter detects a fault condition.

Important

- The fault action is implemented only if **Alert Severity** is set to Failure. If **Alert Severity** is set to any other option, the fault action is not implemented.
- For some faults only: If **Fault Timeout** is set to a non-zero value, the transmitter will not implement the fault action until the timeout has elapsed.

Procedure

- Set **Frequency Output Fault Action** as desired.

Default: Downscale

Important

If you set **Frequency Output Fault Action** to None, the Frequency Output will be controlled by the setting of **Process Variable Fault Action**. In most cases, if you set **Frequency Output Fault Action** to None, you should also set **Process Variable Fault Action** to None.

- If you set **Frequency Output Fault Action** to Upscale, set **Frequency Fault Level** to the desired value.
 - Default: 14500 Hz
 - Range: 10 Hz to 14500 Hz

Related information

[Configure Process Variable Fault Action](#)

Options for Frequency Output Fault Action

Label	Frequency Output behavior
Upscale	Goes to configured Upscale value: <ul style="list-style-type: none"> • Default: 14500 Hz • Range: 10 Hz to 14500 Hz
Downscale	0 Hz
Internal Zero	0 Hz
None (default)	Determined by the setting of Process Variable Fault Action

8.6 Configure a Discrete Output

Use a Discrete Output to report specific meter or process conditions.

8.6.1 Configure Discrete Output Source

Display	Menu → Configuration → Inputs/Outputs → Channel C → I/O Settings → Source
ProLink III	Device Tools → Configuration → I/O → Channels → Channel C → Discrete Output
Web browser	Configuration → Inputs/Outputs → Channel C → Discrete Output

Discrete Output Source specifies the process condition or device condition that is reported by a Discrete Output.

Procedure

Set **Discrete Output Source** to the desired option.

Default: Forward/Reverse

Postrequisites

If you set **Discrete Output Source** to Flow Switch, additional configuration is required.

Related information

[Configure Flow Rate Switch](#)

Options for Discrete Output Source

Option	Label			State	Discrete Output voltage
	Display	ProLink III	Web browser		
Enhanced Event 1–5 ⁽¹⁾	Basic Event x	Enhanced Event x	Enhanced Event x	ON	<ul style="list-style-type: none"> • Internally powered: 24 VDC • Externally powered: Site-specific
				OFF	0 V

Option	Label			State	Discrete Output voltage
	Display	Prolink III	Web browser		
Event 1–2 ⁽²⁾	Enhanced Event x	Event x	N/A	ON	<ul style="list-style-type: none"> Internally powered: 24 VDC Externally powered: Site-specific
				OFF	0 V
Flow Rate Switch	Flow Rate Switch	Flow Switch Indicator	Flow Rate Switch	ON	<ul style="list-style-type: none"> Internally powered: 24 VDC Externally powered: Site-specific
				OFF	0 V
Forward/Reverse Indicator	Flow Direction	Forward Reverse Indicator	Flow Direction	Forward flow	0 V
				Reverse flow	<ul style="list-style-type: none"> Internally powered: 24 VDC Externally powered: Site-specific
Calibration in Progress	Zero in Progress	Calibration in Progress	Zero in Progress	ON	<ul style="list-style-type: none"> Internally powered: 24 VDC Externally powered: Site-specific
				OFF	0 V
Fault	Fault	Fault Indication	Fault	ON	<ul style="list-style-type: none"> Internally powered: 24 VDC Externally powered: Site-specific
				OFF	0 V
Meter Verification Failure	Meter Verification Failure	Meter Verification Failure ⁽³⁾	Meter Verification Failure	ON	<ul style="list-style-type: none"> Internally powered: 24 VDC Externally powered: Site-specific
				OFF	0 V
Batch Primary Valve	Batch Primary Valve	Batch Primary Valve	Batch Primary Valve	ON	<ul style="list-style-type: none"> Internally powered: 24 VDC Externally powered: Site-specific
				OFF	0 V

(1) Events configured using the enhanced event model.

(2) Events configured using the basic event model.

(3) The ProLink III v4.0 option is “Meter Verification Failure” for the **Discrete Output Source** field. This does not match the table entry.

Important

This table assumes that **Discrete Output Polarity** is set to Active High. If **Discrete Output Polarity** is set to Active Low, reverse the voltage values.

Important

Actual flow direction interacts with **Sensor Flow Direction Arrow** to determine the flow direction that the transmitter uses in processing. See the following table.

Table 8-3: Interaction between actual flow direction and Sensor Flow Direction Arrow

Actual flow direction	Setting of Sensor Flow Direction Arrow	Flow direction sent to outputs and totalizers
Forward (same direction as Flow arrow on sensor)	With Arrow	Forward
	Against Arrow	Reverse
Reverse (opposite from Flow arrow on sensor)	With Arrow	Reverse
	Against Arrow	Forward

Related information

[Configure Sensor Flow Direction Arrow](#)

8.6.2 Configure Discrete Output Polarity

Display	Menu → Configuration → Inputs/Outputs → Channel C → I/O Settings → Polarity
ProLink III	Device Tools → Configuration → I/O → Outputs → Discrete Output → Polarity
Web browser	Configuration → Inputs/Outputs → Channel C → Discrete Output → Polarity

A Discrete Output has two states: ON (active, asserted) and OFF (inactive). Two different voltages are used to represent these states. Discrete Output Polarity controls which voltage represents which state.

Procedure

Set **Discrete Output Polarity** as desired.

Default: Active High

8.6.3 Configure Discrete Output Fault Action

Display	
ProLink III	Device Tools → Configuration → I/O → Outputs → Discrete Output → Fault Action
Web browser	Configuration → Inputs/Outputs → Channel C → Discrete Outputs → Fault Action

Discrete Output Fault Action controls the behavior of a Discrete Output if the transmitter detects a fault condition.

Important

- The fault action is implemented only if **Alert Severity** is set to Failure. If **Alert Severity** is set to any other option, the fault action is not implemented.
- For some faults only: If **Fault Timeout** is set to a non-zero value, the transmitter will not implement the fault action until the timeout has elapsed.

NOTICE

Do not use **Discrete Output Source** as a fault indicator. If you do, you may not be able to distinguish a fault condition from a normal operating condition. If you want to use the Discrete Output as a fault indicator, see [Fault indication with a Discrete Output](#).

Procedure

Set **Discrete Output Fault Action** as desired.

Default: None

Related information

[Interaction between Process Variable Fault Action and other fault actions](#)

Options for Discrete Output Fault Action

Label	Discrete Output behavior	
	Polarity=Active High	Polarity=Active Low
Upscale	<ul style="list-style-type: none"> Fault: Discrete Output is ON (24 VDC or site-specific voltage) No fault: Discrete Output is controlled by its assignment 	<ul style="list-style-type: none"> Fault: Discrete Output is OFF (0 V) No fault: Discrete Output is controlled by its assignment
Downscale	<ul style="list-style-type: none"> Fault: Discrete Output is OFF (0 V) No fault: Discrete Output is controlled by its assignment 	<ul style="list-style-type: none"> Fault: Discrete Output is ON (24 VDC or site-specific voltage) No fault: Discrete Output is controlled by its assignment
None (default)	Discrete Output is controlled by its assignment	

Fault indication with a Discrete Output

To indicate faults via a Discrete Output, set **Discrete Output Source** to Fault. Then, if a fault occurs, the Discrete Output is always ON and the setting of **Discrete Output Fault Action** is ignored.

8.7 Configure a Discrete Input

Use a Discrete Input to initiate one or more transmitter actions from a remote input device.

Related information

[Configure a Discrete Input or discrete event](#)

8.7.1 Configure Discrete Input Action

Display	Menu → Configuration → Inputs/Outputs → Channel C → I/O Settings → Assign Actions
ProLink III	Device Tools → Configuration → I/O → Inputs → Action Assignment Device Tools → Configuration → I/O → Inputs → Action Assignment
Web browser	Configuration → Inputs/Outputs → Channel C → Discrete Input → Action Assignment

Discrete Input Action controls the action or actions that the transmitter will perform when the Discrete Input transitions from OFF to ON.

Important

Before assigning actions to a Discrete Input, check the status of the remote input device. If it is ON, all assigned actions will be performed when the new configuration is implemented. If this is not acceptable, change the status of the remote input device or wait until an appropriate time to assign actions.

Procedure

Set **Discrete Input Action** as desired.

Default: None

Options for Discrete Input Action

Action	Label		
	Display	ProLink III	Web browser
Standard			
Start sensor zero	Start Zero Calibration	Start Sensor Zero	Start Sensor Zero
Totalizers			
Start/stop all totalizers and inventories	Start/stop all totalizers	Start or Stop All Totalizers	Start/Stop All Totals
Reset totalizer X	Reset Total X	Totalizer X	Reset Total X
Reset all totalizers and inventories	Reset All Totals	Reset All Totals	Reset All Totals
Concentration measurement			
Increment CM matrix	Increment Matrix	Increment ED Curve	Increment Curve
Meter verification			
Start meter verification test	Start SMV	Start Meter Verification ⁽¹⁾	Start Smart Meter Verification
Batching			
Begin batch	Begin Batch	Begin Batch	Start Batch
End batch	End Batch	End Batch	End Batch
Pause batch	Pause Batch	Pause Batch	Pause Batch
Resume batch	Resume Batch	Resume Batch	Resume Batch
Increment batch preset	Increment Preset	Increment Batch Preset	Increment Preset
Inhibit batch totalizer	Inhibit Totalizer	Inhibit Batch Totalizing	Inhibit Batch Totalizing
Inhibit batch	Inhibit Batch	Inhibit Batch Start	Inhibit Batch Start
Inhibit batch flow	Inhibit Flow	Allow Batch End with Flow	Allow Batch End with Flow

(1) The ProLink III v4.0 field label (Start Smart Meter Verification) does not match the table entry.

8.7.2 Configure Discrete Input Polarity

Display	Menu → Configuration → Inputs/Outputs → Channel C → I/O Settings → Polarity
ProLink III	Device Tools → Configuration → I/O → Inputs → Discrete Input → Discrete Input Polarity
Web browser	Configuration → Inputs/Outputs → Channel C → Discrete Input → Discrete Input Polarity



A Discrete Input has two states: ON and OFF. **Discrete Input Polarity** controls how the transmitter maps the input voltage to the ON and OFF states.

Procedure

Set **Discrete Input Polarity** as desired.

Default: Active Low

Options for Discrete Input Polarity

Polarity	Discrete Input power supply	Voltage	Status of Discrete Input at transmitter
Active High 	Internal	Voltage across terminals is high	ON
		Voltage across terminals is 0 VDC	OFF
	External	Voltage applied across terminals is 3–30 VDC	ON
		Voltage applied across terminals is <0.8 VDC	OFF
Active Low 	Internal	Voltage across terminals is 0 VDC	ON
		Voltage across terminals is high	OFF
	External	Voltage applied across terminals is <0.8 VDC	ON
		Voltage applied across terminals is 3–30 VDC	OFF

9 Set the Ethernet protocol

The primary protocol is configured as either EtherNet/IP, Modbus TCP, or Profinet at the factory per your transmitter's specifications. You can use the display, ProLink III, or the web server to change the factory primary protocol if necessary. The primary protocol determines the state of the LED.

Procedure

Navigate to the **Primary Protocol** field using one of the following tools:

Option	Description
Display	Menu → Configuration → Ethernet Settings → Network Settings
ProLink III	Device Tools → Configuration → Network Settings → Ethernet Protocol
Web server	Configuration → Ethernet Settings → Ethernet Protocol

10 Configure, setup, and use a printer for tickets

10.1 TM-T88VI printer limitations

You can pair up to six 5700 Ethernet transmitters per one Epson TM-T88VI. With any additional connection attempts beyond six, the printer will reject the connection and trigger a functional check alert (printer offline) on the transmitter.

- Maximum simultaneous connections: 6
- Number of connections available for printing: 1
The other five connections must wait until the first print job is completed.
- Default connection time out: 90 seconds
This time out is adjustable using the EpsonNet Config application.

10.2 Set up the printer

Use this section to set up printing with a 5700 Ethernet transmitter and an Epson TM-T88VI printer.

There are two ways to set up printing:

- Use the printer's default IP address
- Change the printer's default IP address

10.2.1 Set up the printer by changing the printer default IP address

Use this procedure to set up printing with a 5700 Ethernet transmitter and an Epson TM-T88VI printer by changing the printer's default IP address.

Procedure

1. Connect one end of an Ethernet cable and power supply to the printer.
2. Connect the other end of the Ethernet cable to the PC.
3. Power on the printer.
The printer IP address prints after a few minutes.
4. Temporarily change the Ethernet address for the PC so that the Ethernet is on the same subnet as the printer:
Default IP address = 192.168.192.168
 - a) From Windows 10, right-click the **Start** button and select **Network Connections**.
 - b) Right-click the Ethernet connection and select **Properties**.
Select **Yes** on any user account pop-up windows.
 - c) Select **Internet Protocol Version 4(TCP/IPv4)**, then select **properties**.

- d) Select **Use the following IP address** and configure the IP address and subnet mask as follows:
 - IP address: 192.168.192.x, where x is something other than 0, 1, or 168
 - Subnet mask: 255.255.255.0
 - e) Select **OK**.
5. Change the printer firmware options.
 - a) Open your web browser and type `http://192.168.192.168` (default printer IP).
The browser displays, `Your connection is not private`. Ignore the warning and proceed to the website.
 - b) Select **ADVANCED**.
 - c) Select **Proceed to 192.168.192.168**.
 - d) At the login screen, enter:

Default username: `epson`

Default password: `epson`

The EpsonNet Config utility screen displays.
 - e) Select **TCP/IP** under the configuration settings (not the basic settings), listed on the left side of the screen.
 - f) Change the **IP Address** (i.e., 192.168.1.55), **Subnet Mask**, and **Default Gateway** based on your network. Select an IP address that is unique to the local network.
The printer must be on the same subnet as the 5700.
 - g) Required: Set **Acquiring the IP Address** to Manual.
 - h) Select **Send** to save your settings.
 - i) Select **Reset**, or power cycle the printer when prompted to apply the changes.
 6. Change the PC network settings back to the original settings.
Use the windows you used in [Step 4](#).
 7. Configure the 5700 Ethernet transmitter for the printer.
 - a) Remove the Ethernet cable from the PC and connect it to the 5700 Ethernet transmitter.
 - b) If you have not already done so, configure the transmitter IP address, subnet mask, and default gateway.

Display	Menu → Configuration → Ethernet Settings → Network Settings
ProLink III	Device Tools → Configuration → Network Settings

See [Connect ProLink III to the transmitter](#).

- c) Enter the printer IP address you configured in the previous step into the 5700 Ethernet transmitter.

Display	Menu → Configuration → Printer → Printer IP address
ProLink III	Device Tools → Configuration → Printer and Tickets
Web browser	Configuration → Printer and Tickets

- 8. Perform a test print to verify the settings are correct.

Display	Menu → Operations → Printer → Print Ticket → Print Test Page
ProLink III	Device Tools → Configuration → Printer and Tickets
Web browser	Configuration → Printer and Tickets

If needed, see *Function Check Failed* in the *Status alerts, causes, and recommendations* section.

10.2.2 Set up the printer using the printer default IP address

Use this procedure to set up printing with a 5700 Ethernet transmitter and an Epson TM-T88VI printer using the printer's default IP address.

Procedure

1. Connect one end of an Ethernet cable and power supply to the printer.
2. Connect the other end of the Ethernet cable to the PC.
3. Power on the printer.

It can take 1-2 minutes for the printer to finish configuring network settings. When complete, the following ticket prints.

```

*****
IP Address : 192.168.192.168
SubnetMask : 255.255.255.0
Gateway : 0.0.0.0 DHCP : No server - > Static
*****
    
```

- 4. Turn off DHCP if it is enabled.

From the display	From ProLink III
a. Go to Menu → Configuration → Ethernet Settings → Network Settings → Auto obtain IP()DHCP . b. Select Disabled and Save . c. Back out to the Ethernet Settings page to apply the DHCP off setting.	a. Go to Device Tools → Configuration → Network Settings . b. Uncheck Obtain an IP address automatically (DHCP) . c. Select Apply .

5. Configure the IP address.

a) Navigate to one of the following screens:

From the display	From ProLink III
Go to Menu → Configuration → Ethernet Settings → Network Settings → IP address.	Go to Device Tools → Configuration → Network Settings.

b) Set the IP address to 192.168.192.x, where x is something other than 0, 1, or 168.

6. Configure the subnet mask.

a) Navigate to one of the following screens:

From the display	From ProLink III
Go to Menu → Configuration → Ethernet Settings → Network Settings → Subnet Mask.	Go to Device Tools → Configuration → Network Settings.

b) Set the subnet mask to 255.255.255.0.

7. Configure the printer type.

a) Navigate to one of the following screens:

From the display	From ProLink III
Go to Menu → Configuration → Printer → Printer Type.	Go to Device Tools → Configuration → Printer and Tickets.

b) Verify that the IP address is 192.168.192.168.

10.3 Reset the interface settings

Use this procedure if you forgot the IP address of your printer and need to reset the default (192.168.192.168).

Procedure

1. Turn off the printer and close the roll paper cover.
2. If the connector cover is attached, remove the cover.
3. Hold down the status sheet button on the back of the printer while turning on the printer. A message displays indicating that resetting is being performed.
4. Release the status sheet button to reset the printer settings to default.

Important

Do not turn off power until the process is complete.

When complete, a `Resetting to Factory Default Finished` message displays.

10.4 Configure the printer and print tickets

Prerequisites

This procedure assumes that all variables and units of precision are already configured.

Verify that you have the correct software versions and licenses.

Software or license version	Where to look
ProLink III 4.2 or later	From ProLink III, Help
Transmitter software 2.0 or later	<ul style="list-style-type: none"> From the display: Menu → About → Versions → Transmitter Software From ProLink III, Device Tools → About → Versions → Transmitter Software

Procedure

1. Ensure that the transmitter is in unsecure mode in order to make the configuration changes for this procedure.
2. Configure the printer parameters.

Display	Menu → Configuration → Printer
ProLink III	Device Tools → Configuration → Printer and Tickets
Web browser	Not available

Related information

[Upgrade the transmitter firmware](#)
[Printer, ticket, and heading parameters](#)

10.4.1 Printer, ticket, and heading parameters

Table 10-1: Printer configurable parameters

Ticket parameters	Description
Printer Type	<ul style="list-style-type: none"> Epson TM-T88VI – Uses 3.15 in (80.0 mm) thermal paper rolls Generic – does not support the Paper Out function
Printer IP Address	Default values: Left Most Octet: 192 Left Middle Octet: 168 Right Middle Octet: 192 Right Most Octet: 168 Modify the default values based on the network using the printer.

Table 10-2: Ticket configurable parameters

Ticket parameters	Description
Number of Batch Tickets	The number of batch tickets to be printed by the Auto Print function (if Auto Print is enabled) or by a manual print request. The default is 1.
Auto Print	<ul style="list-style-type: none">• Select Yes to have batch tickets printed automatically at the end of each batch. Tickets will be printed only if flow is stopped.• Select No to not have batch tickets printed automatically at the end of each batch.
Batch Count Start Number	Starting ticket number for the batch count.

Table 10-3: Header Lines 1 – 2

Heading parameters	Description
Text	Enter the text for this line of the header. Enter up to 20 characters. Leave blank for no text.
Number of Line Feeds	Configure the space between the current line and the following line by 1, 2, or 3 lines. Default is 1.
Font Size	<ul style="list-style-type: none">• Normal Height• Double Height

Related information

[Configure the printer and print tickets](#)

10.5 Configure a Discrete Input or discrete event

You can configure the 5700 so that:

- A standard or batch ticket is printed when a Discrete Input is activated or automatically after a discrete event occurs

Procedure

1. Configure a channel for Discrete Input.
2. Configure the channel to print a ticket.

Related information

[Configure a Discrete Input](#)

10.6 Ticket types

Tickets provide proof of what was purchased, as well as status summaries.

You can configure any of the following ticket types using varying methods.

Table 10-4: Ticket type descriptions

Ticket type	Description
Standard	Prints alerts and other maintenance occurrences for information only. Standard tickets are not legal for trade.
Batch	Prints proof of batching operations. Batch tickets are used when the Weights & Measures application is not licensed.
Batch (NTEP)	Batch tickets that are used when: <ul style="list-style-type: none"> The Weights & Measures application is licensed World Area is set to NTEP

- For some ticket types, you can include or exclude content.
- You can configure tickets to print automatically – for example, at certain points in a discrete batch, or when an event occurs.
- You can print tickets manually as needed, using either the display or a Discrete Input.

Table 10-5: Ticket types for special applications

Special applications	Available tickets		
	Standard	Batch	Batch (NTEP)
None	X		
Discrete batch license	X	X	
Custody transfer application (NTEP) Requires discrete batch application	X		X Legal receipt

10.6.1 Print a standard ticket

You can print standard tickets using the display or through a Discrete Input. You can also specify that tickets will be printed automatically if a discrete event occurs. You may use as many of these methods as desired.

Procedure

To print standard tickets from the display, select the ticket from **Menu** → **Operations** → **Printer** → **Print Ticket**.

- Print None
- Print Process Screen
- Print Batch Ticket
- Print Config Data
- Print Alert History
- Print Active Alerts
- Print Audit Trail
- Print Test Page

For examples, see [Example tickets](#).

Note

Print Audit Trail and Print Config Data tickets are long prints.

10.6.2 Print a batch ticket

Batch tickets provide proof of batching operations.

Procedure

1. To manually print a batch ticket, go to the display and navigate to **Menu** → **Batcher** → **Run Batch** → **Print Batch Ticket**.
2. To configure the transmitter to automatically print batch tickets after a batch end:
 - From the display, navigate to **Menu** → **Configuration** → **Printer** → **Ticket Settings**
 - From ProLink III, navigate to **Device Tools** → **Configuration** → **Batcher** → **Auto Print Ticket at Batch End** and select Yes.
3. You can also write a 1 to Modbus coil 383 to print a batch ticket.

Batch ticket contents

Table 10-6: Batch ticket contents

Ticket type	Header lines	Standard ticket contents	Conditional ticket contents
Batch	1 and 2	<ul style="list-style-type: none"> • Batch data and time • Only batch data • Batch count • Print timestamp 	“Not Legal For Trade” banner Appears only when discrete batch is licensed and the Weights and Measures application is not licensed.
Batch (NTEP)	1 and 2	<ul style="list-style-type: none"> • Batch data and time • Batch data • Batch count number Also called BOL number 	<ul style="list-style-type: none"> • “Duplicate” banner • “Security Breach” banner • “Not Legal For Trade” banner

Figure 10-1: Batch ticket example

HEADER	1
HEADER	2
HEADER	3
HEADER	4
FT-0000	
30-JUN-2017	11:32:17
Total:	0.0 g
Batch Count:	0
FOOTER	

For more examples, see [Example tickets](#).

11 Complete the configuration

11.1 Test or tune the system using sensor simulation

Display	Menu → Service Tools → Sensor Simulation → Simulate Sensor
ProLink III	Device Tools → Diagnostics → Testing → Sensor Simulation
Web browser	Service Tools → Simulation → Sensor Simulation

Use sensor simulation to test the system's response to a variety of process conditions, including boundary conditions, problem conditions, or alert conditions, or to tune the loop.

Restriction

Sensor simulation is available only on flow meters with the enhanced core processor.

Prerequisites

Before enabling sensor simulation, ensure that your process can tolerate the effects of the simulated process values.

Procedure

1. Enable sensor simulation.
2. For mass flow, set **Wave Form** as desired and enter the required values.

Option	Required values
Fixed	Fixed Value
Sawtooth	Period Minimum Maximum
Sine	Period Minimum Maximum

3. For density, set **Wave Form** as desired and enter the required values.

Option	Required values
Fixed	Fixed Value
Sawtooth	Period Minimum Maximum
Sine	Period Minimum Maximum

- For temperature, set **Wave Form** as desired and enter the required values.

Option	Required values
Fixed	Fixed Value
Sawtooth	Period Minimum Maximum
Sine	Period Minimum Maximum

- Observe the system response to the simulated values and make any appropriate changes to the transmitter configuration or to the system.
- Modify the simulated values and repeat.
- When you have finished testing or tuning, disable sensor simulation.

11.1.1 Sensor simulation

Sensor simulation allows you to test the system or tune the loop without having to create the test conditions in your process. When sensor simulation is enabled, the transmitter reports the simulated values for mass flow, density, and temperature, and takes all appropriate actions. For example, the transmitter might apply a cutoff, activate an event, or post an alert.

When sensor simulation is enabled, the simulated values are stored in the same memory locations used for process data from the sensor. The simulated values are then used throughout transmitter functioning. For example, sensor simulation will affect:

- All mass flow rate, temperature, and density values displayed or reported via outputs or digital communications
- The mass total and mass inventory values
- All volume calculations and data, including reported values, volume totals, and volume inventories
- All mass, temperature, density, or volume values logged to Data Logger

Sensor simulation does not affect any diagnostic values.

Unlike actual mass flow rate and density values, the simulated values are not temperature-compensated (adjusted for the effect of temperature on the sensor's flow tubes).

11.2 Enable or disable software write-protection

Display	Use the mechanical switch on the display.
ProLink III	Device Tools → Configuration → Write-Protection
Web browser	Configuration → Security → Write Protection

When enabled, **Write-Protection** prevents changes to the transmitter configuration. You can perform all other functions, and you can view the transmitter configuration parameters.

Note

The write protection setting via software methods (such as ProLink III) is available only on transmitters without a display.

For transmitters with a display, write protection is available only using the lock switch on the display. See [Lock or unlock the transmitter](#).

Write-protecting the transmitter primarily prevents accidental changes to configuration, not intentional changes. Any user who can make changes to the configuration can disable write protection.

12 Transmitter operation

12.1 View process and diagnostic variables

Process variables provide information about the state of the process fluid. Diagnostic variables provide data about device operation. You can use this data to monitor and troubleshoot your process.

12.1.1 View process and diagnostic variables using the display

The display reports the name of the variable (for example, *Density*), the current value of the variable, and the associated unit of measure (for example, kg/m³).

Prerequisites

For a process or diagnostic variable to be viewed using the display, it must be configured as a display variable.

Procedure

- If **Auto Scroll** is not enabled, activate ↓ or ↑ to move through the list of display variables.
- If **Auto Scroll** is enabled, wait until the variable is displayed automatically. If you do not want to wait, you can activate ↓ or ↑ to force the display to scroll.

12.1.2 View process variables and other data using ProLink III

Monitor process variables, diagnostic variables, and other data to maintain process quality.

ProLink III automatically displays process variables, diagnostic variables, and other data on the main screen.

Tip

ProLink III allows you to choose the process variables that appear on the main screen. You can also choose whether to view data in Analog Gauge view or digital view, and you can customize the gauge settings. For more information, see the *Micro Motion ProLink III with ProcessViz Software User Manual*.

12.1.3 View process variables and other data using a web browser

Monitor process variables, diagnostic variables, and other data to maintain process quality.

When you log in to the transmitter with a web browser, the **Process Monitor** page automatically displays process variables, diagnostic variables, and other data. You can change which variables appear on the page.

Procedure

1. Click **Change Displayed Variables**.
2. Make a new selection for each display variable you want to change.
3. Click **Apply**.

12.1.4 Effect of Sensor Flow Direction Arrow on digital communications

Flow rates on the transmitter display or reported via digital communications are shown as positive or negative. The sign depends on the interaction between **Sensor Flow Direction Arrow** and the actual flow direction.

This interaction affects flow rates shown on the transmitter display, ProLink III, and all other user interfaces.

Actual flow direction	Setting of Sensor Flow Direction Arrow	Flow rate value	
		Transmitter display	Digital communications
Forward (same direction as Flow arrow on sensor)	With Arrow	Positive (no sign)	Positive
	Against Arrow	Negative	Negative
Reverse (opposite from Flow arrow on sensor)	With Arrow	Negative	Negative
	Against Arrow	Positive (no sign)	Positive

12.2 View and acknowledge status alerts

The transmitter posts a status alert whenever one of the specified conditions occurs. You can view active alerts and you can acknowledge alerts. You do not have to acknowledge alerts: The transmitter will perform normal measurement and reporting functions with unacknowledged alerts.

12.2.1 View and acknowledge alerts using the display

You can view information about all active or unacknowledged alerts, and you can acknowledge alerts.

The display uses the alert banner and the alert symbol ⓘ to provide information about alerts.

Table 12-1: Alert information on display

Display status	Cause	User action
Alert banner	One or more alerts are active.	Resolve the conditions to clear the alert. When the alert is cleared or acknowledged, the banner will be removed.
Alert symbol ⓘ	One or more alerts are unacknowledged.	Acknowledge the alert. When all alerts are acknowledged, the alert icon will be removed.

If alert security is enabled, the alert banner is never displayed. To view detailed information, you must use the alert menu: **Menu** → **(i) Alert List**.

Note

Certain alerts do not clear until the transmitter is rebooted.

Procedure

- If the alert banner appears:
 - a) Activate **Info** to view information about the alert.
 - b) Take appropriate steps to clear the alert.
 - c) Activate **Ack** to acknowledge the alert.

- If ⓘ appears:
 - a) Choose **Menu** → **(i) Alert List**.
 - b) Select an alert to view more information about the specific alert or to acknowledge it individually.
 - c) Choose **Acknowledge All Alerts** to acknowledge all alerts on the list.

12.2.2 View and acknowledge alerts using ProLink III

You can view a list containing all alerts that are active, or inactive but unacknowledged. From this list, you can acknowledge individual alerts or choose to acknowledge all alerts at once.

Note

Certain alerts do not clear until the transmitter is rebooted.

Procedure

1. View alerts on the ProLink III main screen under **Alerts**.
All active or unacknowledged alerts are listed. Take appropriate steps to clear all active alerts.
2. To acknowledge a single alert, check the **Ack** check box for that alert. To acknowledge all alerts at once, select **Ack All**.

12.2.3 View alerts using a web browser

You can view a list containing all alerts that are active, or inactive but unacknowledged. From this list, you can acknowledge individual alerts or choose to acknowledge all alerts at once.

Active alerts automatically appear on the **Process Monitor** page when you log in to the transmitter from a web browser.

Note

Certain alerts do not clear until the transmitter is rebooted.

Procedure

1. Choose **Alerts** to display the **Alerts** page.
Alerts are shown in the **Active Alert List**.
2. For inactive alerts click **Alert History** to view them in the browser, or click **Download Full Alert History** to generate a text file that you can download to your PC.

12.3 Read totalizer and inventory values

Display	Menu → Operations → Totalizers → See Totals
ProLink III	Device Tools → Totalizer Control → Totalizers Device Tools → Totalizer Control → Inventories
Web browser	Operations → Totalizers Operations → Inventories

Totalizers keep track of the total amount of mass or volume measured by the transmitter since the last totalizer reset. Inventories keep track of the total amount of mass or volume measured by the transmitter since the last inventory reset.

12.4 Start, stop, and reset totalizers and inventories

When a totalizer or inventory is started, its value increases or decreases depending on the interaction of the flow direction parameters. It continues tracking flow until it is stopped.

When a totalizer or inventory is reset, its value is set to 0. You can reset a totalizer or inventory while it is started or while it is stopped.

- You can start, stop, or reset each totalizer or inventory independently.
- You can start, stop, or reset all totalizers and inventories as a group.

12.4.1 Start, stop, and reset totalizers using the display

Prerequisites

To stop, start, or reset a single totalizer or inventory, the totalizer or inventory must be configured as a display variable.

To reset an inventory using the display, this function must be enabled. To enable inventory reset using the display, choose **Menu** → **Configuration** → **Security** and set **Totalizer Reset** to Allowed. Note that this affects only the display functions. Resetting inventories using other tools is not affected.

Procedure

- To start or stop a single totalizer or inventory:
 - a) Wait or scroll until the totalizer or inventory appears on the display.
 - b) Choose **Options**.
 - c) Choose **Start** or **Stop**.
- To start or stop all totalizers and inventories as a group:
 - a) Choose **Menu** → **Operations** → **Totalizers**.
 - b) Choose **Start** or **Stop**.
- To reset a single totalizer or inventory:
 - a) Wait or scroll until the totalizer or inventory appears on the display.
 - b) Choose **Options**.
 - c) Choose **Reset**.
- To reset all totalizers and inventories as a group:
 - a) Choose **Menu** → **Operations** → **Totalizers**.
 - b) Choose **Reset All**.

12.4.2 Start, stop, and reset totalizers using ProLink III

Prerequisites

To reset an inventory using ProLink III, this function must be enabled. To enable inventory reset using ProLink III, choose **Tools** → **Options** and enable **Reset Inventories from ProLink III**. Note that this affects only ProLink III. Resetting inventories using other tools is not affected.

Procedure

- To start or stop a single totalizer:
 - a) Choose **Device Tools** → **Totalizer Control** → **Totalizers**.
 - b) Scroll to the totalizer that you want to start or stop, and click **Start** or **Stop**.
- To start or stop a single inventory:
 - a) Choose **Device Tools** → **Totalizer Control** → **Inventories**.
 - b) Scroll to the inventory that you want to start or stop, and click **Start** or **Stop**.
- To start or stop all totalizers as a group:
 - a) Choose **Device Tools** → **Totalizer Control** → **Totalizers** or **Device Tools** → **Totalizer Control** → **Inventories**.
 - b) Select **Start All Totals** or **Stop All Totals**.
- To reset a single totalizer:
 - a) Choose **Device Tools** → **Totalizer Control** → **Totalizers**.
 - b) Scroll to the totalizer that you want to reset, and click **Reset**.
- To reset a single inventory:
 - a) Choose **Device Tools** → **Totalizer Control** → **Inventories**.
 - b) Scroll to the inventory that you want to reset, and click **Reset**.
- To reset all totalizers as a group:
 - a) Choose **Device Tools** → **Totalizer Control** → **Totalizers**.
 - b) Select **Reset All Totals**.
- To reset all inventories as a group:
 - a) Choose **Device Tools** → **Totalizer Control** → **Inventories**.
 - b) Select **Reset All Inventories**.

12.4.3 Start, stop, and reset totalizers using a web browser

You can start and stop each totalizer or inventory independently. You can start and stop all totalizers as a group. You can reset each totalizer or inventory independently. You can reset all totalizers as a group. You can reset all inventories as a group.

When a totalizer or inventory is started, its value increases or decreases depending on the interaction of the flow direction parameters. It continues tracking flow until it is stopped.

When a totalizer or inventory is reset, its value is set to 0. You can reset a totalizer or inventory while it is started or while it is stopped.

Procedure

- To start, stop, or reset totalizers:
 - a) Choose **Operations** → **Totalizers**.
 - b) Choose from the available operations.

Option	Description
Start	Start an individual totalizer.
Stop	Stop an individual totalizer.
Reset	Reset an individual totalizer to zero.
Start all Totalizers	Start all totalizers at the same time.
Stop all Totalizers	Stop all totalizers at the same time.
Reset all Totalizers	Reset all totalizers to zero at the same time.

- To start, stop, or reset inventories:
 - a) Choose **Operations** → **Inventories**.
 - b) Choose from the available operations.

Option	Description
Start	Start an individual inventory.
Stop	Stop an individual inventory.
Reset	Reset an individual inventory to zero.
Reset all Inventories	Resets all inventories to zero the same time.

13 Operation using the batcher

13.1 Run a batch

You can run a batch using any of the presets that are enabled. You can change the target for the current batch. You can pause and resume a batch in process. You can allow the batch to complete normally or you can end it manually.

Restriction

Presets are not available when using a web browser for configuration.

Prerequisites

The preset that you want to use must be enabled.

Procedure

1. Select the preset you want to use.

Option	Description
Display	Choose Menu → Batcher → Run Batch and set Active Preset to the preset you want to use.
ProLink III	Choose Device Tools → Configuration → Batcher and set Current Preset Number to the preset you want to use.
Web browser	Not available.

The preset contains parameters that control batch processing.

2. If desired, change the configured target to the target to be used for this batch only.

Option	Description
Display	Choose Current Preset Number to the preset you want to use, and set Batch Target to the desired value.
ProLink III	Choose Device Tools → Application Control → Run Batcher and set Current Target to the desired value.
Web browser	Choose Operations → Batcher → Run Batcher and set Current Preset Number to the preset you want to use.

You cannot set the target to a value that is greater than the **Maximum Target** value configured for the batching application.

Changing the target here does not change the target configured in the preset.

3. Begin the batch.

Option	Description
Display	Choose Menu → Batcher → Run Batch → Batch Control and select Begin .
ProLink III	Choose Device Tools → Application Control → Run Batch and select Begin Batch .
Web browser	Choose Operations → Batcher → Run Batcher and select Begin Batch .

The transmitter automatically resets the batch total to 0 if you have selected **Reset on Start**. Otherwise, you must manually reset the batch total before the batch will start.

Reset on Start is not applicable for custody transfer batcher applications.

4. Monitor the batch during processing.

Option	Description
Display	Choose Menu → Batcher → Run Batch → Batch Control and observe the value displayed in Actual Total .
ProLink III	Choose Device Tools → Application Control → Run Batcher and observe the values displayed in Current Total and Batch Time .
Web browser	Choose Operations → Batcher → Run Batcher and observe the values displayed in Current Total and Batch Time .

5. Optional: Pause the batch at any time.

Option	Description
Display	Choose Menu → Batcher → Run Batch → Batch Control and select Pause .
ProLink III	Choose Device Tools → Application Control → Run Batcher and select Pause Batcher .
Web browser	Choose Operations → Batcher → Run Batcher and select Pause Batch .

Pausing a batch allows you to resume it later.

6. Optional: Resume the batch after it has been paused.

Option	Description
Display	Choose Menu → Batcher → Run Batch → Batch Control and select Resume .
ProLink III	Choose Menu → Batcher → Run Batch → Batch Control and select Resume .
Web browser	Choose Operations → Batcher → Run Batcher and select Resume Batch .

- Optional: End the batch manually at any time before it reaches the target.

Option	Description
Display	Choose Menu → Batcher → Run Batch → Batch Control and select End .
ProLink III	Choose Device Tools → Application Control → Run Batcher and select End Batch .
Web browser	Choose Operations → Batcher → Run Batcher and select End Batch .

If you end a batch manually, you will not be able to resume it. You can end the batch while it is running and while it is paused.

- If you did not end the batch manually, wait until the batch ends automatically.

Option	Description
Display	Choose Menu → Batcher → Run Batch → Batch Control .
ProLink III	Choose Device Tools → Application Control → Run Batcher .
Web browser	Choose Operations → Batcher → Run Batcher and select End Batch .

The batch ends automatically when it reaches the target or when it reaches the configured maximum fill time.

- Optional: Inhibit batch.

Option	Description
Display	Not available.
ProLink III	Choose Device Tools → Application Control → Run Batcher .
Web browser	Choose Operations → Batcher → Run Batcher .

While the **Inhibit Batch** input is active, a batch will not be allowed to start. Attempting to start a batch while the batch is inhibited will cause the Start Not Okay alarm to be posted.

- Optional: Inhibit totalizer.

Option	Description
Display	Not available.
ProLink III	Choose Device Tools → Application Control → Run Batcher .
Web browser	Choose Operations → Batcher → Run Batcher .

When the **Inhibit Totalizer** input is active, the **Batch Total** will not increment. A timeout alarm will occur if the **Batch Total** is inhibited beyond the max batch time. The batch inventory for the current preset will not increment while **Inhibit Totalizer** is active.

11. Optional: Inhibit flow.

Option	Description
Display	Not available.
ProLink III	Choose Device Tools → Application Control → Run Batcher .
Web browser	Choose Operations → Batcher → Run Batcher .

When the **Inhibit Flow** input is active, the batch will ignore the flow rate of the assigned flow source, allowing a batch to end. The batch total will not increment when flow is inhibited.

13.2 Perform AOC calibration

AOC calibration “trains” the AOC algorithm to adjust for your network speed and valve closure speed. AOC calibration is required only if **AOC Compensation Mode** is set to AOC Algorithm.

There are two options for AOC calibration:

- Calculate and save: When you are satisfied with the results of AOC calibration, you can save the current AOC coefficient. It will be used for all batches.
- Rolling calibration: The AOC coefficient is recalculated for each batch, based on the results of the most recent batches.

Prerequisites

Compensation Mode must be set to AOC.

13.2.1 Perform AOC calibration using the display

Procedure

- To calculate and save an AOC coefficient:
 - a) Choose **Menu** → **Operations** → **Batcher** → **AOC Calibration**.
 - b) Set **AOC Cal Status** to On.
 - c) Run several batches, allowing each batch to run to completion, and observe the totals.
 - d) When batch repeatability meets requirements, set **AOC Cal Status** to Off.
AOC calibration is stopped, and the current coefficient is saved.

Important

If you are using a saved value, repeat AOC calibration:

- Whenever the fluid characteristics change, especially viscosity
 - Whenever you change any configuration parameter that can affect flow measurement (e.g., damping)
-

- To set up rolling calibration:
 - a) Choose **Menu** → **Operations** → **Batcher** → **AOC Calibration**.
 - b) Set **AOC Window** to the number of batches that the rolling AOC coefficient will be based on.
 - c) Set **AOC Cal Status** to On.

Important

If you are using rolling calibration, and fluid characteristics change or the transmitter configuration changes, the transmitter will automatically adjust to the new conditions after a few batches.

13.2.2 Perform AOC calibration using ProLink III

Procedure

- To calculate and save an AOC coefficient:
 - a) Choose **Device Tools** → **Application Control** → **Run Batcher**.
 - b) Click **Start AOC Calibration**.
 - c) Run several batches, allowing each batch to run to completion, and observe the totals.
 - d) When batch repeatability meets requirements, click **Save AOC Calibration**.
AOC calibration is stopped, and the current coefficient is saved.

Important

If you are using a saved value, repeat AOC calibration:

- Whenever the fluid characteristics change, especially viscosity
 - Whenever you change any configuration parameter that can affect flow measurement (e.g., damping)
-

- To set up rolling calibration:
 - a) Choose **Device Tools** → **Configuration** → **Batcher**.
 - b) Set **AOC Window Length** to the number of batches that the rolling AOC coefficient will be based on.
 - c) Choose **Device Tools** → **Application Control** → **Run Batcher**.
 - d) Click **Start AOC Calibration**.

Important

If you are using rolling calibration, and fluid characteristics change or the transmitter configuration changes, the transmitter will automatically adjust to the new conditions after a few batches.

13.2.3 Perform AOC calibration using a web browser

Procedure

- To calculate and save an AOC coefficient:
 - a) Choose **Operations** → **Run Batcher** → **AOC Calibration**.
 - b) Select **Start AOC Calibration**.

- c) Run several batches, allowing each batch to run to completion, and observe the totals.
- d) When batch repeatability meets requirements, click **Save AOC Calibration**.

AOC calibration is stopped, and the current coefficient is saved.

Important

If you are using a saved value, repeat AOC calibration:

- Whenever the fluid characteristics change, especially viscosity
 - Whenever you change any configuration parameter that can affect flow measurement (e.g., damping)
-

14 Measurement support

14.1 Use Smart Meter Verification

Smart Meter Verification™ provides in-process flow meter health verification by analyzing the meter components related to measurement performance. You can run Smart Meter Verification without stopping the process. Use this section to run a Smart Meter Verification test, view and interpret the results, set up automatic execution, and check if a field reference point has been established.

Important

Run the first Smart Meter Verification Basic or Professional test when the flow meter is installed in the pipeline and the flow meter is at its normal operating conditions.

Prerequisites

The following information pertains to 5700 Ethernet firmware \geq v2.10.

- To avoid or reduce corrosion, erosion, and other process effects, make sure the sensor tube material is compatible with the process fluid in use. For more information, see the *Micro Motion Corrosion Guide*.
- **Important**
Micro Motion highly recommends:
 - Running the first Smart Meter Verification test when the flow meter is installed in the pipeline according to the installation instructions, and the process is running at its normal operating conditions
 - Running all tests thereafter at similar operating conditions
- The Smart Meter Verification test runs best when process conditions are stable. If process conditions are too unstable, the test will abort. To maximize process stability:
 - Maintain a constant fluid temperature and pressure.
 - Maintain a constant flow rate. If possible, stop flow through the sensor. The sensor should be full of process fluid.
 - Avoid changes to fluid composition; for example, two-phase flow or settling.
- For all applications, run Smart Meter Verification while commissioning the meter at normal operating conditions and then run it regularly. Micro Motion also recommends using Smart Meter Verification results along with other diagnostics like drive gain and density to help determine the health of a sensor.
- In certain scenarios, Smart Meter Verification field upgrades for pre-installed meters are possible. Contact factory support to discuss pre-installed meter upgrades.

14.1.1 Smart Meter Verification capabilities

Capability	Basic	Professional
	Included	90-day trial, licensed
Calibration coefficients audit	•	•
Zero audit	•	•
Electronics verification	•	•

Capability	Basic	Professional
	Included	90-day trial, licensed
Automatic test scheduler	•	•
History of previous 20 results	•	•
Verification report		• ⁽¹⁾
Non-uniform coating diagnostic		•
Multiphase diagnostic		• ⁽²⁾
Flow range diagnostic		• ⁽²⁾

(1) Create and export with ProLink III, web page, or AMS SNAP-ON.

(2) 24-hour historian visualization in ProLink III Professional

14.1.2 Run a Smart Meter Verification test

Run a Smart Meter Verification Basic or Professional test to diagnose the flow meter (and flow meter system) and verify if the flow meter is functioning properly and performing within factory specifications.

Important

Run the first Smart Meter Verification Basic or Professional test when the flow meter is installed in the pipeline and the flow meter is at its normal operating conditions.

Run a Smart Meter Verification test using the display

Procedure

1. Read the Smart Meter Verification prerequisites in [Use Smart Meter Verification](#) if you have not done so already.
2. Choose **Menu** → **Operations** → **Smart Meter Verification** → **Run Verification**.
3. Select the desired output behavior.

Option	Description
Continue Measuring	During the test, all outputs will continue to report their assigned process variables. The test will run for approximately 90 seconds.
Fix at Last Measured Value	During the test, all outputs will report the last measured value of their assigned process variable. The test will run for approximately 140 seconds.
Fix at Fault	During the test, all outputs will go to their configured fault action. The test will run for approximately 140 seconds.

The test starts immediately.

4. Wait for the test to complete.

Note

At any time during the process, you can abort the test. If the outputs were fixed, they will return to normal behavior.

Run a Smart Meter Verification test using ProLink III Basic or Professional

Procedure

1. Read the Smart Meter Verification prerequisites in [Use Smart Meter Verification](#) if you have not done so already.
2. Run Smart Meter Verification Basic or Professional using ProLink III Basic or Professional:
 - Smart Meter Verification Basic: **Device Tools** → **Diagnostics** → **Meter Verification** → **Basic Meter Verification**
 - Smart Meter Verification Professional: **Smart Meter Verification Overview** → **Meter Verification** → **Run Verification**
 - Smart Meter Verification Professional: **Device Tools** → **Diagnostics** → **Meter Verification** → **Run Test**

3. In the *SMV Test Definition* window, enter any desired information and click **Next**.

None of this information is required. It does not affect Smart Meter Verification processing.

ProLink III stores this information in the Smart Meter Verification database on the PC. It is not saved to the transmitter.

4. Select the desired output behavior.

Option	Description
Continue Measuring	During the test, all outputs will continue to report their assigned process variables. The test will run for approximately 90 seconds.
Fix at Last Measured Value	During the test, all outputs will report the last measured value of their assigned process variable. The test will run for approximately 140 seconds.
Fix at Fault	During the test, all outputs will go to their configured fault action. The test will run for approximately 140 seconds.

5. Select **Start** and wait for the test to complete.

Note

At any time during the process, you can abort the test. If the outputs were fixed, they will return to normal behavior.

Run a Smart Meter Verification test using a web browser

Procedure

1. Read the Smart Meter Verification prerequisites in [Use Smart Meter Verification](#) if you have not done so already.
2. Choose **Service Tools** → **Smart Meter Verification** → **Run Meter Verification**.

3. Select the desired output behavior.

Option	Description
Continue Measuring	During the test, all outputs will continue to report their assigned process variables. The test will run for approximately 90 seconds.
Fix at Last Measured Value	During the test, all outputs will report the last measured value of their assigned process variable. The test will run for approximately 140 seconds.
Fix at Fault	During the test, all outputs will go to their configured fault action. The test will run for approximately 140 seconds.

4. Select **Start** and wait for the test to complete.

Note

At any time during the process, you can abort the test. If the outputs were fixed, they will return to normal behavior.

14.1.3 View Smart Meter Verification test results

When the Smart Meter Verification Basic test is complete, a pass/fail result is displayed. With Smart Meter Verification Professional, detailed results and reports are available.

Note

With Smart Meter Verification Professional, the twenty most recent results are available. If viewed using ProLink III Basic or Professional, results for all tests that are in the PC database are available.

View Smart Meter Verification test results using the display

Results of the current Smart Meter Verification Basic or Professional test display automatically after the test is complete.

With Smart Meter Verification Professional, use the following procedure to view previous test results.

Procedure

1. Choose **Menu** → **Operations** → **Smart Meter Verification** → **Read Verification History**.
2. To view detailed data for an individual test, select it from the list.

View Smart Meter Verification test results using ProLink III Basic or Professional

Results of the current Smart Meter Verification Basic or Professional test display automatically after the test is complete.

With Smart Meter Verification Professional, use the following procedure to view previous test results.

To generate a previous test report, the Smart Meter Verification Professional test must have been run on the current PC in use.

Procedure

1. Choose one of the following options:
 - **Device Tools** → **Diagnostics** → **Meter Verification** → **View Previous Test Results**
 - **Smart Meter Verification Overview** → **Meter Verification** → **History**
2. To view details, choose the results of interest: **Show Report** (or **Next** to show the report). ProLink III displays a report containing details of the most recent tests. The report is automatically saved to the Smart Meter Verification database. You can print or export the report.

View Smart Meter Verification test results using a web browser

Results of the current Smart Meter Verification Basic or Professional test display automatically after the test is complete.

With Smart Meter Verification Professional, use the following procedure to view previous test results.

Procedure

1. Choose **Service Tools** → **Smart Meter Verification** → **Meter Verification History**.
2. Under **Meter Verification History**, select + in the row next to the test date you want to view.

Interpreting Smart Meter Verification results

When the Smart Meter Verification Basic or Professional test is completed, the result is reported as Pass, Fail, or Abort. (Some tools report the Fail result as `Advisory` instead.)

Pass The meter is performing within factory specifications.

Abort When you execute a Smart Meter Verification Basic or Professional test, the test performs a self-diagnostic check to ensure that the flow meter is stable prior to running the test. In the rare case that this check reveals an issue, Smart Meter Verification will report an abort code.

If you manually cancel an in-process Smart Meter Verification Basic or Professional test, the test result displays `Abort Code 1: User-Initiated Abort`. In this case, you can restart Smart Meter Verification without any further action. In the rare case any other abort occurs, contact factory support.

In all cases where a Smart Meter Verification Professional test aborts, no report will be generated.

Fail If a Smart Meter Verification Basic or Professional test ran at normal operating conditions while conditions were stable and failed, see [Resolve a failed Smart Meter Verification test](#) to determine the appropriate actions.

14.1.4 Resolve a failed Smart Meter Verification test

Use this procedure if a Smart Meter Verification Basic or Professional test ran at normal operating conditions while conditions were stable and failed.

Procedure

1. Verify the sensor by performing a visual inspection, density verification, or field proving.

2. If possible, run Smart Meter Verification Professional with ProLink III Basic or Professional and save the results as follows:
 - In a `.csv` file
 - In a report
 - If the transmitter has a historian, retrieve the Smart Meter Verification results from the service or historian files.
3. Contact the factory for further evaluation and instructions.

14.1.5 Set up Smart Meter Verification automatic execution

You can execute a Smart Meter Verification Basic or Professional test on demand or automatically schedule future runs. You can schedule future runs via two different options: as a single test at a user-defined future time, or automatically on a regular schedule.

Tip

The time between test runs must be between 1 and 1000 hours. The time for the first test run can be any positive floating number.

Set up Smart Meter Verification automatic execution using the display

Procedure

1. Choose **Menu** → **Operations** → **Smart Meter Verification** → **Schedule Verification**.
2. To schedule a single test:
 - a) Set **Hours to 1st Run** to the number of hours to elapse before the test is run.
 - b) Set **Hours Between** to 0.
3. To schedule a recurring execution:
 - a) Set **Specify Time Until Next Run** to the number of days, hours, and minutes to elapse before the first test is run.
 - b) Set **Specify Time Between Recurring Runs** to the number of days, hours, and minutes to elapse between runs.
4. To disable scheduled execution:
 - a) Set **Specify Time Until Next Run** to 0 **days**, 0 **hours**, and 0 **minutes**.
 - b) Set **Specify Time Between Recurring Runs** to 0 **days**, 0 **hours**, and 0 **minutes**.

Set up Smart Meter Verification automatic execution using ProLink III Basic or Professional

Procedure

1. Select one of the following paths to access the Smart Meter Verification scheduler .
 - ProLink III Basic or Professional: Choose **Device Tools** → **Diagnostics** → **Meter Verification** → **Schedule Meter Verification**.
 - ProLink III Professional: Choose **Smart Meter Verification Overview** → **Tools** → **Schedule Smart Meter Verification**.
2. To schedule a single test:
 - a) Set **Specify Time Until Next Run** to the number of days, hours, and minutes to elapse before the test is run.
 - b) Set **Specify Time Between Recurring Runs** to **0 days, 0 hours, and 0 minutes**.
3. To schedule a recurring execution:
 - a) Set **Specify Time Until Next Run** to the number of days, hours, and minutes to elapse before the first test is run.
 - b) Set **Specify Time Between Recurring Runs** to the number of days, hours, and minutes to elapse between runs.
4. To disable scheduled execution, choose **Disable Scheduled Execution**.

Set up Smart Meter Verification automatic execution using a web browser

Procedure

1. Choose **Service Tools** → **Smart Meter Verification** → → **Schedule Meter Verification**.
2. To schedule a single test:
 - a) Set **Hours Until Next Run** to the number of hours to elapse before the test is run.
 - b) Set **Hours Between Recurring Runs** to **0**.
3. To schedule recurring execution:
 - a) Set **Hours Until Next Run** to the number of hours to elapse before the first test is run.
 - b) Set **Hours Between** to the number of hours to elapse between runs.
4. To disable scheduled execution, choose **Disable Scheduled Execution**.
5. Select **Apply**.

Check for a field reference point

Use this procedure to check if a field reference point was created.

Prerequisites

- Smart Meter Verification Professional

- ProLink III Basic or Professional
- 5700 Ethernet firmware \geq v2.10

Procedure

1. From ProLink III Basic or Professional, choose one of the following options:
 - **Device Tools** → **Diagnostics** → **Meter Verification** → **View Previous Test Results**
 - **Smart Meter Verification Overview** → **Meter Verification** → **History**
2. Select **Export Data to CSV File**.
3. Save the CSV file to your computer.
4. Locate and open the CSV file.
5. Locate and examine the two columns labeled, **SMV Meter Factor LPO** and **SMV Meter Factor RPO**.
 - If the field reference point has not been established, the numbers in both columns will be exactly 1.
 - If the field reference point has been established, the numbers located in both columns will be close to 1. The **SMV Meter Factor LPO** and **SMV Meter Factor RPO** numbers do not have to match.

14.2 Advanced Phase Measurement

Micro Motion Advanced Phase Measurement software improves long-term flow reporting and measurement performance in processes with intermittent periods of two-phase flow, including liquids with entrained gas or gas with entrained liquid. If Advanced Phase Measurement is combined with the Net Oil or concentration measurement software options, the software can also report liquid concentration, Net Oil, and/or Gas Void Fraction (GVF) during the same two-phase conditions. For more information, see the *Micro Motion Advanced Phase Measurement Application Manual*.

The following measurement options are available with Advanced Phase Measurement software:

- Net Oil
- Liquid with Gas
- Gas with Liquid

Note

Each option is licensed separately in the transmitter. Field upgrades are permitted.

Table 14-1: Net oil options (choose one)

License option (ordering code)	Description	Availability
MA — Manual Advanced Phase Measurement configuration	Suitable for a mixture of oil and water under predictable flow conditions. Includes manual drive gain threshold only. This option is the 5700 upgrade for Production Volume Reconciliation (PVR).	Do not combine with APM liquid with gas (option PL) — basic remediation for gas is included.
PO — Net Oil	Suitable for mixtures of oil and water. Add PL option to remediate for gas.	Can be combined with APM license code PL. PL is recommended since most net oil applications contain gas.

Table 14-2: Liquid with gas

License option (ordering code)	Description	Availability
PL — Advanced Phase Measurement Liquid with Gas	Suitable for any liquid with entrained gas.	Can be combined with APM license code PO. Can be combined with license code concentration measurement (CM).

Table 14-3: Gas with liquid

License option (ordering code)	Description	Availability
PG — Advanced Phase Measurement Gas with Liquid	Suitable for any gas that may contain entrained liquids (mist).	Cannot be activated with any other license code.

14.3 Piecewise linearization (PWL) for calibrating gas meters

Piecewise linearization (PWL) can linearize the measurements of flow meters for greater accuracy in order to measure gas over a wide range of flow rates. PWL does not apply when measuring liquid flow. When better accuracy is required over the published gas measurement specifications, an Emerson-approved independent gas laboratory can calibrate gas up to 10 PWL adjustment points.

For more information, see the white paper, *The Practical Application of Multi-Point Piecewise Linear Interpolation (PWL) and Other Developing Trends with Coriolis Meters for Natural Gas Custody Transfer Applications*, available at www.emerson.com.

You can use ProLink III or the Ethernet web pages to view the PWL points that are stored, and to capture them in the uploaded and downloaded configuration files.

14.3.1 Configure PWL

Display	Not available
ProLink III	Device Tools → Configuration → Process Measurement → Piecewise Linearization for Gas (PWL)
Web browser	Configuration → Process Measurement → Piecewise Linearization for Gas

14.4 Zero the meter

Display	Menu → Service Tools → Verification & Calibration → Meter Zero → Zero Calibration
ProLink III	Device Tools → Calibration → Smart Zero Verification and Calibration → Calibrate Zero
Web browser	Service Tools → Verification and Calibration → Meter Zero → Calibrate Zero

Zeroing the meter establishes a baseline for process measurement by analyzing the sensor's output when there is no flow through the sensor tubes.

Important

In most cases, the factory zero is more accurate than the field zero. Do not zero the meter unless one of the following is true:

- The zero is required by site procedures.
- The stored zero value fails the zero verification procedure.

Do not verify the zero or zero the meter if a high-severity alert is active. Correct the problem, then verify the zero or zero the meter. You may verify the zero or zero the meter if a low-severity alert is active.

Prerequisites

Before performing a field zero, execute the zero verification procedure to see whether or not a field zero can improve measurement accuracy.

Important

Do not verify the zero or zero the meter if a high-severity alert is active. Correct the problem, then verify the zero or zero the meter. You may verify the zero or zero the meter if a low-severity alert is active.

Procedure

1. Prepare the meter:
 - a) Allow the meter to warm up for at least 20 minutes after applying power.
 - b) Run the process fluid through the sensor until the sensor temperature reaches the normal process operating temperature.
 - c) Stop flow through the sensor by shutting the downstream valve, and then the upstream valve if available.
 - d) Verify that the sensor is blocked in, that flow has stopped, and that the sensor is completely full of process fluid.
 - e) Observe the drive gain, temperature, and density readings. If they are stable, check the **Live Zero** or **Field Verification Zero** value. If the average value is close to 0, you should not need to zero the meter.
2. Modify **Zero Time**, if desired.

Zero Time controls the amount of time the transmitter takes to determine its zero-flow reference point. The default **Zero Time** is 20 seconds. For most applications, the default **Zero Time** is appropriate.
3. Start the zero procedure and wait until it completes.

When the calibration is complete:

 - If the zero procedure was successful, a `Calibration Success` message and a new zero value are displayed.
 - If the zero procedure failed, a `Calibration Failed` message is displayed.

Postrequisites

Restore normal flow through the sensor by opening the valves.

Need help?

If the zero fails:

- Ensure that there is no flow through the sensor, then retry.
- Remove or reduce sources of electromechanical noise, then retry.

- Set **Zero Time** to a lower value, then retry.
- If the zero continues to fail, contact customer service.
- If you want to restore the most recent valid value from transmitter memory:
 - Using the display: **Menu** → **Service Tools** → **Verification and Calibration** → **Meter Zero** → **Restore Zero** → **Restore Previous Zero**
 - Using ProLink III: **Device Tools** → **Calibration** → **Smart Zero Verification and Calibration** → **Calibrate Zero** → **Restore Prior Zero**
- If you want to restore the factory zero:
 - Using the display: **Menu** → **Service Tools** → **Verification and Calibration** → **Meter Zero** → **Restore Zero** → **Restore Factory Zero**
 - Using ProLink III: **Device Tools** → **Calibration** → **Smart Zero Verification and Calibration** → **Calibrate Zero** → **Restore Factory Zero**

Restriction

Restore the factory zero only if your meter was purchased as a unit, it was zeroed at the factory, and you are using the original components.

Related information

[Verify the zero](#)

14.4.1 Terminology used with zero verification and zero calibration

Term	Definition
Zero	In general, the offset required to synchronize the left pickoff and the right pickoff under conditions of zero flow. Unit = microseconds.
Factory Zero	The zero value obtained at the factory, under laboratory conditions.
Field Zero	The zero value obtained by performing a zero calibration outside the factory.
Prior Zero	The zero value stored in the transmitter at the time a field zero calibration is begun. May be the factory zero or a previous field zero.
Manual Zero	The zero value stored in the transmitter, typically obtained from a zero calibration procedure. It may also be configured manually. Also called “mechanical zero” or “stored zero”.
Live Zero	The real-time bidirectional mass flow rate with no flow damping or mass flow cutoff applied. An adaptive damping value is applied only when the mass flow rate changes dramatically over a very short interval. Unit = configured mass flow measurement unit.
Zero Stability	A laboratory-derived value used to calculate the expected accuracy for a sensor. Under laboratory conditions at zero flow, the average flow rate is expected to fall within the range defined by the Zero Stability value ($0 \pm$ Zero Stability). Each sensor size and model has a unique Zero Stability value.
Zero Calibration	The procedure used to determine the zero value.
Zero Time	The time period over which the Zero Calibration procedure is performed. Unit = seconds.

Term	Definition
Field Verification Zero	A 3-minute running average of the Live Zero value, calculated by the transmitter. Unit = configured mass flow measurement unit.
Zero Verification	A procedure used to evaluate the stored zero and determine whether or not a field zero can improve measurement accuracy.

14.5 Set up pressure compensation

Pressure compensation adjusts process measurement to compensate for the pressure effect on the sensor. The pressure effect is the change in the sensor's sensitivity to flow and density caused by the difference between the calibration pressure and the process pressure.

Tip

Not all sensors or applications require pressure compensation. The pressure effect for a specific sensor model can be found in the product data sheet located at www.emerson.com. If you are uncertain about implementing pressure compensation, contact customer service.

Prerequisites

You will need the flow factor, density factor, and calibration pressure values for your sensor.

- For the flow factor and density factor, see the product data sheet for your sensor.
- For the calibration pressure, see the calibration sheet for your sensor. If the data is unavailable, use 20 psi (1.38 bar).

You must be able to supply pressure data to the transmitter.

14.5.1 Set up pressure compensation using the display

Procedure

1. Choose **Menu** → **Configuration** → **Process Measurement** → **Pressure**.
2. Set **Units** to the pressure unit used by the external pressure device.
3. Enter **Flow Factor** for your sensor.

The flow factor is the percent change in the flow rate per PSI. When entering the value, reverse the sign.

Example

If the flow factor is -0.0002% per PSI, enter $+0.0002\%$ per PSI.

4. Enter **Density Factor** for your sensor.

The density factor is the change in fluid density, in $\text{g/cm}^3/\text{PSI}$. When entering the value, reverse the sign.

Example

If the density factor is $-0.000006\text{ g/cm}^3/\text{PSI}$, enter $+0.000006\text{ g/cm}^3/\text{PSI}$.

5. Set **Calibration Pressure** to the pressure at which your sensor was calibrated.

The calibration pressure is the pressure at which your sensor was calibrated, and defines the pressure at which there is no pressure effect. If the data is unavailable, enter 20 PSI.

Postrequisites

Option	Description	Setup
Digital communications	A host writes pressure data to the meter at appropriate intervals.	<ol style="list-style-type: none"> 1. Set Pressure Source to Fixed Value or Digital Communications. 2. Perform the necessary host programming and communications setup to write pressure data to the meter at appropriate intervals.

Choose **Menu** → **Service Tools** → **Service Data** → **View Process Variables** and verify the external pressure value.

Need help?

If the value is not correct:

- Ensure that the external device and the meter are using the same measurement unit.
- For digital communications, verify that the host has access to the required data.

14.5.2 Set up pressure compensation using ProLink III

Procedure

1. Choose **Device Tools** → **Configuration** → **Process Measurement** → **Pressure Compensation**.
2. Set **Pressure Compensation Status** to Enabled.
3. Set **Pressure Unit** to the unit used by the external pressure device.
4. Enter the **Density Factor** and **Flow Factor** for your sensor.
 - a) Set **Process Fluid** to Liquid Volume or Gas Standard Volume, as appropriate.
 - b) Compare the values shown in **Recommended Density Factor** and **Recommended Flow Factor** to the values from the product data sheet.
 - c) To use the recommended values, click **Accept Recommended Values**.
 - d) To use different factors, enter your values in the **Density Factor** and **Flow Factor** fields.

The density factor is the change in fluid density, in g/cm³/PSI. When entering the value, reverse the sign.

Example

If the density factor is -0.000006 g/cm³/PSI, enter +0.000006 g/cm³/PSI.

The flow factor is the percent change in the flow rate per PSI. When entering the value, reverse the sign.

Example

If the flow factor is -0.0002% per PSI, enter $+0.0002\%$ per PSI.

5. Set **Flow Calibration Pressure** to the pressure at which your sensor was calibrated.

The calibration pressure is the pressure at which your sensor was calibrated, and defines the pressure at which there is no pressure effect. If the data is unavailable, enter 20 PSI.

6. Choose the method you will use to supply pressure data, and perform the required setup.

Option	Description	Setup
Digital communications	A host writes pressure data to the meter at appropriate intervals.	<ol style="list-style-type: none"> a. Set Pressure Source to Fixed Value or Digital Communications. b. Perform the necessary host programming and communications setup to write pressure data to the meter at appropriate intervals.

Postrequisites

The current pressure value is displayed in the **External Pressure** field. Verify that the value is correct.

Need help?

If the value is not correct:

- Ensure that the external device and the meter are using the same measurement unit.
- For digital communications, verify that the host has access to the required data.

14.5.3 Set up pressure compensation using a web browser

Procedure

1. Choose **Configuration** → **Process Measurement** → **Pressure**.
2. Set **Pressure Compensation Status** to Enabled.
3. Set **Pressure Unit** to the unit used by the external pressure device.
4. Enter the **Density Factor** and **Flow Factor** for your sensor.
 - a) Set **Process Fluid** to Liquid Volume or Gas Standard Volume, as appropriate.
 - b) Compare the values shown in **Recommended Density Factor** and **Recommended Flow Factor** to the values from the product data sheet.
 - c) To use the recommended values, click **Accept Recommended Values**.
 - d) To use different factors, enter your values in the **Density Factor** and **Flow Factor** fields.

The density factor is the change in fluid density, in $\text{g/cm}^3/\text{PSI}$. When entering the value, reverse the sign.

Example

If the density factor is $-0.000006\text{ g/cm}^3/\text{PSI}$, enter $+0.000006\text{ g/cm}^3/\text{PSI}$.

The flow factor is the percent change in the flow rate per PSI. When entering the value, reverse the sign.

Example

If the flow factor is -0.0002 % per PSI, enter +0.0002 % per PSI.

5. Set **Flow Calibration Pressure** to the pressure at which your sensor was calibrated.

The calibration pressure is the pressure at which your sensor was calibrated, and defines the pressure at which there is no pressure effect. If the data is unavailable, enter 20 PSI.

6. Choose the method you will use to supply pressure data, and perform the required setup.

Option	Description	Setup
Digital communications	A host writes pressure data to the meter at appropriate intervals.	<ol style="list-style-type: none"> Set Pressure Source to Fixed Value or Digital Communications. Perform the necessary host programming and communications setup to write pressure data to the meter at appropriate intervals.

Postrequisites

The current pressure value is displayed in the **External Pressure** field. Verify that the value is correct.

Need help?

If the value is not correct:

- Ensure that the external device and the meter are using the same measurement unit.
- For digital communications, verify that the host has access to the required data.

14.6 Validate the meter

Display	Menu → Configuration → Process Measurement → Flow Variables → Mass Flow Settings → Meter Factor Menu → Configuration → Process Measurement → Flow Variables → Volume Flow Settings → Meter Factor Menu → Configuration → Process Measurement → Density → Meter Factor
ProLink III	Device Tools → Configuration → Process Measurement → Flow → Mass Flow Rate Meter Factor Device Tools → Configuration → Process Measurement → Flow → Volume Flow Rate Meter Factor Device Tools → Configuration → Process Measurement → Density → Density Meter Factor
Web browser	Configuration → Process Measurement → Flow Variables → Mass Flow Rate Meter Factor Configuration → Process Measurement → Flow Variables → Volume Flow Rate Meter Factor Configuration → Process Measurement → Density → Density Meter Factor

Meter validation compares flow meter measurements reported by the transmitter to an external measurement standard. If the transmitter value for mass flow, volume flow, or density measurement is significantly different from the external measurement standard, you may want to adjust the corresponding

meter factor. The flow meter's actual measurement is multiplied by the meter factor, and the resulting value is reported and used in further processing.

Prerequisites

Identify the meter factor(s) that you will calculate and set. You may set any combination of the three meter factors: mass flow, volume flow, and density. Note that all three meter factors are independent:

- The meter factor for mass flow affects only the value reported for mass flow.
- The meter factor for density affects only the value reported for density.
- The meter factor for volume flow affects only the value reported for volume flow or gas standard volume flow.

Important

To adjust volume flow, you must set the meter factor for volume flow. Setting a meter factor for mass flow and a meter factor for density will not produce the desired result. The volume flow calculations are based on original mass flow and density values, before the corresponding meter factors have been applied.

If you plan to calculate the meter factor for volume flow, be aware that validating volume in the field may be expensive, and the procedure may be hazardous for some process fluids. Therefore, because volume is inversely proportional to density, an alternative to direct measurement is to calculate the meter factor for volume flow from the meter factor for density. For instructions on this method, see [Alternate method for calculating the meter factor for volume flow](#).

Obtain a reference device (external measurement device) for the appropriate process variable.

Important

For good results, the reference device must be highly accurate.

Procedure

1. Determine the meter factor as follows:
 - a) Use the flow meter to take a sample measurement.
 - b) Measure the same sample using the reference device.
 - c) Calculate the meter factor using the following formula:

$$NewMeterFactor = ConfiguredMeterFactor \times \left(\frac{ReferenceMeasurement}{FlowmeterMeasurement} \right)$$

2. Ensure that the calculated meter factor does not fall outside 0.98 and 1.02. If the meter factor is outside these limits, contact customer service.
3. Configure the meter factor in the transmitter.

Calculating the meter factor for mass flow

The flow meter is installed and validated for the first time. The mass flow measurement from the transmitter is 250.27 lb. The mass flow measurement from the reference device is 250 lb. The mass flow meter factor is calculated as follows:

$$MeterFlow_{MassFlow} = 1 \times \left(\frac{250}{250.27} \right) = 0.9989$$

The first meter factor for mass flow is 0.9989.

One year later, the flow meter is validated again. The mass flow measurement from the transmitter is 250.07 lb. The mass flow measurement from the reference device is 250.25 lb. The new mass flow meter factor is calculated as follows:

$$MeterFlow_{MassFlow} = 0.9989 \times \left(\frac{250.25}{250.07} \right) = 0.9996$$

The new meter factor for mass flow is 0.9996.

14.6.1 Alternate method for calculating the meter factor for volume flow

The alternate method for calculating the meter factor for volume flow is used to avoid the difficulties that may be associated with the standard method.

This alternate method is based on the fact that volume is inversely proportional to density. It provides partial correction of the volume flow measurement by adjusting for the portion of the total offset that is caused by the density measurement offset. Use this method only when a volume flow reference is not available, but a density reference is available.

Procedure

1. Calculate the meter factor for density, using the standard method.
2. Calculate the meter factor for volume flow from the meter factor for density:

$$MeterFactor_{Volume} = \left(\frac{1}{MeterFactor_{Density}} \right)$$

The following equation is mathematically equivalent to the first equation. You may use whichever version you prefer.

$$MeterFactor_{Volume} = ConfiguredMeterFactor_{Density} \times \left(\frac{Density_{Flowmeter}}{Density_{ReferenceDevice}} \right)$$

3. Ensure that the calculated meter factor does not fall outside 0.98 and 1.02. If the meter factor is outside these limits, contact customer service.
4. Configure the meter factor for volume flow in the transmitter.

14.7 Perform a (standard) D1 and D2 density calibration

Density calibration establishes the relationship between the density of the calibration fluids and the signal produced at the sensor. Density calibration includes the calibration of the D1 (low-density) and D2 (high-density) calibration points.

Important

Micro Motion flow meters are calibrated at the factory, and normally do not need to be calibrated in the field. Calibrate the flow meter only if you must do so to meet regulatory requirements. Contact customer support before calibrating the flow meter.

Tip

Use meter validation and meter factors, rather than calibration, to prove the meter against a regulatory standard or to correct measurement error.

Prerequisites

- During density calibration, the sensor must be completely filled with the calibration fluid, and flow through the sensor must be at the lowest rate allowed by your application. This is usually accomplished by closing the shutoff valve downstream from the sensor, then filling the sensor with the appropriate fluid.
- D1 and D2 density calibration require a D1 (low-density) fluid and a D2 (high-density) fluid. You may use air and water.
- The calibrations must be performed without interruption, in the order shown. Make sure that you are prepared to complete the process without interruption.
- Before performing the calibration, record your current calibration parameters. You can do this by saving the current configuration to a file on the PC. If the calibration fails, restore the known values.

14.7.1 Perform a D1 and D2 density calibration using the display

Procedure

1. Read the Prerequisites in [Perform a \(standard\) D1 and D2 density calibration](#) if you have not already done so.
2. Close the shutoff valve downstream from the sensor.
3. Fill the sensor with the D1 fluid and allow the sensor to achieve thermal equilibrium.
4. Choose **Menu** → **Service Tools** → **Verification and Calibration** → **Density Calibration**.
5. Perform the D1 calibration.
 - a) Choose **D1 (Air)**.
 - b) Enter the density of your D1 fluid.
 - c) Choose **Start Calibration**.
 - d) Wait for the calibration to complete.
 - e) Choose **Finished**.
6. Fill the sensor with the D2 fluid and allow the sensor to achieve thermal equilibrium.
7. Perform the D2 calibration.
 - a) Choose **D2 (Water)**.
 - b) Enter the density of your D2 fluid.
 - c) Choose **Start Calibration**.
 - d) Wait for the calibration to complete.
 - e) Choose **Finished**.
8. Open the shutoff valve.

14.7.2 Perform a D1 and D2 density calibration using ProLink III

Procedure

1. Read the Prerequisites in [Perform a \(standard\) D1 and D2 density calibration](#) if you have not already done so.

2. See the following figure.

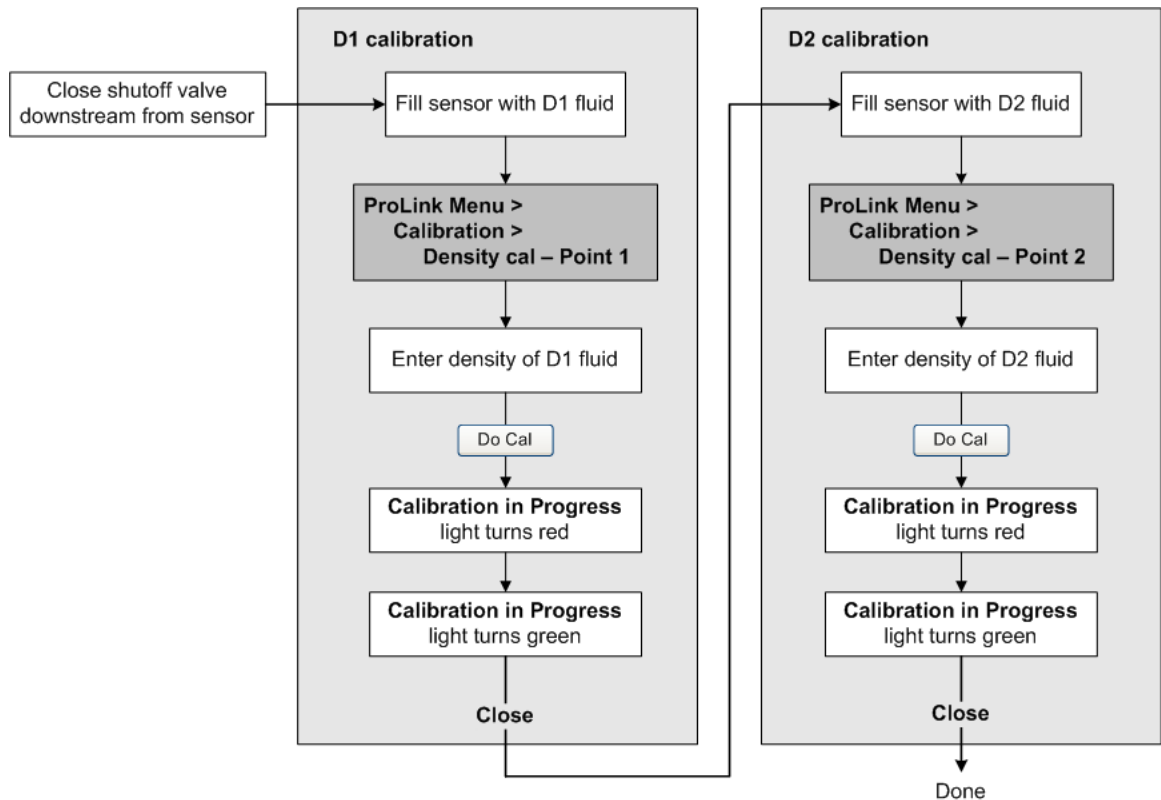

14.7.3 Perform a D1 and D2 density calibration using a web browser

Procedure

1. Read the Prerequisites in [Perform a \(standard\) D1 and D2 density calibration](#) if you have not already done so.
2. Close the shutoff valve downstream from the sensor.
3. Fill the sensor with D1 fluid.
4. Choose **Service Tools** → **Verification and Calibration** → **Point 1 (Air)**
5. Enter the correct value for **Density of Calibration Fluid**.
6. Click **Start Calibration**.
7. Wait for the calibration process to complete.
8. Fill the sensor with D2 fluid.
9. Choose **Service Tools** → **Verification and Calibration** → **Point 2 (Water)**
10. Enter the correct value for **Density of Calibration Fluid**.
11. Click **Start Calibration**.
12. Wait for the calibration process to complete.

14.8 Adjust concentration measurement with Trim Offset

Trim Offset adjusts the meter's concentration measurement to match a reference value.

Tip

You can adjust concentration measurement by applying the trim offset only, or by applying both the trim offset and the trim slope. For most applications, the trim offset is sufficient.

Prerequisites

Ensure that the active matrix is the one that you want to trim. You can set the offset separately for each matrix on your transmitter.

You must be able to take a sample of your process fluid and obtain a laboratory concentration value at line density and line temperature.

Procedure

1. Take a concentration reading from the meter, and record line density and line temperature.
2. Take a sample of the process fluid and obtain a laboratory value for concentration at line density and line temperature, in the units used by the meter.
3. Subtract the meter value from the laboratory value.
4. Enter the result as the trim offset.
 - Using ProLink III: Choose **Device Tools** → **Configuration** → **Process Measurement** → **Concentration Measurement**, set **Matrix Being Configured** to your matrix, and enter **Trim Offset**.
5. Take another concentration reading from the meter, and compare it to the laboratory value.
 - If the two values are acceptably close, the trim is complete.
 - If the two values are not acceptably close, repeat this procedure.

Calculating the trim offset

Laboratory value	64.21 °Brix
Meter value	64.93 °Brix

$$64.21 - 64.93 = -0.72$$

Concentration offset: -0.72

14.9 Adjust concentration measurement with Trim Slope and Trim Offset

Trim Slope and **Trim Offset** adjust the meter's concentration measurement to match a reference value.

Tip

You can adjust concentration measurement by applying the trim offset only, or by applying both the trim offset and the trim slope. For most applications, the trim offset is sufficient.

Prerequisites

Ensure that the active matrix is the one that you want to trim. You can set the offset and slope separately for each matrix on your transmitter.

You must be able to take measurements of your process fluid at two different concentrations.

You must be able to take a sample of your process fluid at each of these concentrations.

For each sample, you must be able to obtain a laboratory concentration value at line density and line temperature.

Procedure

1. Collect data for Comparison 1.
 - a) Take a concentration reading from the meter and record line density and line temperature.
 - b) Take a sample of the process fluid at the current concentration.
 - c) Obtain a laboratory value for concentration at line density and line temperature, in the units used by the meter.
2. Collect data for Comparison 2.
 - a) Change the concentration of your process fluid.
 - b) Take a concentration reading from the meter and record line density and line temperature.
 - c) Take a sample of the process fluid at the current concentration.
 - d) Obtain a laboratory value for concentration at line density and line temperature, in the units used by the meter.

3. Populate the following equation with values from each comparison.

$$\text{Concentration}_{\text{Lab}} = (A \times \text{Concentration}_{\text{Meter}}) + B$$

4. Solve for A (slope).
5. Solve for B (offset), using the calculated slope and one set of values.
6. Enter the results as the trim slope and the trim offset.
 - Using ProLink III: Choose **Device Tools** → **Configuration** → **Process Measurement** → **Concentration Measurement**, set **Matrix Being Configured** to your matrix, and enter **Trim Slope** and **Trim Offset**.
 - Using a web browser: Choose **Configure**
7. Take another concentration reading from the meter, and compare it to the laboratory value.
 - If the two values are acceptably close, the trim is complete.
 - If the two values are not acceptably close, repeat this procedure.

Calculating the trim slope and the trim offset

Comparison 1	Laboratory value	50.00%
	Meter value	49.98%
Comparison 2	Laboratory value	16.00%
	Meter value	15.99%

Populate the equations:

$$50 = (A \times 49.98) + B$$

$$16 = (A \times 15.99) + B$$

Solve for A:

$$50.00 - 16.00 = 34.00$$

$$49.98 - 15.99 = 33.99$$

$$34 = A \times 33.99$$

$$A = 1.00029$$

Solve for B:

$$50.00 = (1.00029 \times 49.98) + B$$

$$50.00 = 49.99449 + B$$

$$B = 0.00551$$

Concentration slope (A): 1.00029

Concentration offset (B): 0.00551

15 Maintenance

15.1 Install a new transmitter license

Display	Menu → Service Tools → License Manager
ProLink III	Device Tools → Configuration → Feature License
Web browser	Service Tools → License Manager

Whenever you purchase additional features or request a trial license, you must install a new transmitter license. The new license makes the new features available on your transmitter. For concentration measurement and API Referral, you may still need to enable the application.

Prerequisites

- You must have a license file provided by Micro Motion:
 - `perm.lic`: Permanent license file
 - `temp.lic`: Temporary license file
- A USB drive

If you are planning to use the USB drive, the service port must be enabled. It is enabled by default. However, if you need to enable it, choose **Menu → Configuration → Security** and set **Service Port** to On.

Procedure

- To install a license using the display:
 - a) Copy the license file to a folder on a USB drive.

Important

You must copy the license file to a folder. You cannot put it in the root.

- b)  **WARNING**
If the transmitter is in a hazardous area, do not remove the housing cover while the transmitter is powered up. Failure to follow these instructions can cause an explosion resulting in injury or death.

Open the wiring compartment on the transmitter and insert the USB drive into the service port.

- c) Choose **Menu → USB Options → USB Drive → Transmitter → Load License File**.
 - d) Select the folder containing the license file and follow the prompts.
- To install a license using ProLink III:
 - a) Open the license file.
 - b) Choose **Device Tools → Configuration → Feature License**.
 - c) Copy the license from the file to the appropriate **License Key** field.

- To install a license using a web browser:
 - a) Open the license file.
 - b) Choose **Service Tools** → **License Manager**.
 - c) Copy the license from the file to the appropriate **License Key** field.

The features supported by the new license are displayed.

If you installed a temporary license, the transmitter will revert to its original feature set when the license period has expired. To purchase a feature for permanent use, contact customer support.

Postrequisites

If you installed a permanent license, update the options model code to match the new license. The options model code represents the installed features.

15.2 Upgrade the transmitter firmware

You can upgrade the transmitter firmware to stay current with development and to take advantage of any new features.

15.2.1 Using a USB drive with the display

You can upgrade the transmitter firmware to stay current with development and to take advantage of any new features.

Prerequisites

You must have the firmware upgrade files provided by Micro Motion.

The service port must be enabled. It is enabled by default. However, if you need to enable it, choose **Menu** → **Configuration** → **Security** and set **Service Port** to On.

Procedure

1. Copy the folder containing the firmware upgrade files to a USB drive.
2.  **WARNING**
If the transmitter is in a hazardous area, do not remove the housing cover while the transmitter is powered up. Failure to follow these instructions can cause an explosion resulting in injury or death.

Open the wiring compartment and insert the USB drive into the service port.

3. Follow the prompts once the transmitter recognizes the USB drive.
4. Select **USB Drive** → **Transmitter**.
5. Select **Update Device Software**.
6. Select the firmware upgrade folder and follow the prompts.

Note

If required, the transmitter upgrade procedure automatically includes an upgrade to the core processor software.

If you chose to reboot the transmitter at a later date, you can reboot it from the menu, or you can power-cycle it.

7. Verify the transmitter configuration and all safety parameters.
8. Enable write-protection.

15.2.2 Using the USB service port and ProLink III

You can upgrade the transmitter firmware to stay current with development and to take advantage of any new features.

WARNING

If the transmitter is in a hazardous area, do not remove the housing cover while the transmitter is powered up. Failure to follow these instructions can cause an explosion resulting in injury or death.

Prerequisites

You must have the firmware upgrade files provided by Emerson.

Procedure

1. Choose **Device Tools** → **Transmitter Software Update**.
2. Navigate to the folder containing the firmware upgrade files.
3. Select **Update**.

Note

If required, the transmitter upgrade procedure automatically includes an upgrade to the core processor software.

If you chose to reboot the transmitter at a later date, you can reboot it from the display, or you can power-cycle it.

4. Verify the transmitter configuration and all safety parameters.
5. Enable write-protection.

15.3 Reboot the transmitter

Display	Menu → Service Tools → Reboot Transmitter
ProLink III	Not available
Web browser	Not available

For certain configuration changes to take effect, the transmitter must be rebooted. You must also reboot the transmitter in order to clear certain status alerts.

Rebooting the transmitter has the same effect as power-cycling the transmitter.

Prerequisites

Follow appropriate procedures to select the appropriate time for rebooting the transmitter. The reboot typically takes about 10 seconds.

Postrequisites

Check the transmitter clock. During the reboot, the transmitter clock is powered by the battery, therefore the transmitter clock and all timestamps should be accurate. If the transmitter clock is not correct, the battery may need replacement.

15.4 Battery replacement

The transmitter contains a battery that is used to power the clock when the transmitter is not powered up. Users cannot service or replace the battery. If the battery requires replacement, contact customer support.

If the battery is non-functional and the transmitter is powered down, then powered up, the clock will restart from the time of the power-down. All timestamps will be affected. You can correct the issue by resetting the transmitter clock. For a permanent resolution, the battery must be replaced.

16 Log files, history files, and service files

16.1 Generate history files

Display	Menu → USB Options → Transmitter → USB Drive → Download Historical Files
ProLink III	Device Tools → Configuration Transfer → Download Historical Files
Web browser	Service Tools → Download Device Files

The transmitter automatically saves historical data of several types, including process and diagnostic variables, Smart Meter Verification test results, and totalizer values. To access the historical data, you can generate a log file, then view it on your PC.

WARNING

If the transmitter is in a hazardous area, do not remove the housing cover while the transmitter is powered up. Failure to follow these instructions can cause an explosion resulting in injury or death.

Prerequisites

If you want to generate a totalizer log, you must have previously configured the transmitter to record totalizer data. However, there is a totalizer history that is logged automatically.

If you plan to use the transmitter display:

- The service port must be enabled. It is enabled by default. However, if you need to enable it, choose **Menu** → **Configuration** → **Security** and set **Service Port** to On.
- You must have a USB drive.

Procedure

1.  **WARNING**

If the transmitter is in a hazardous area, do not remove the housing cover while the transmitter is powered up. Failure to follow these instructions can cause an explosion resulting in injury or death.

If you are using the transmitter display, open the wiring compartment and insert the USB drive into the service port.

2. Select the type of log file that you want to generate.
3. If you selected historian data (process and diagnostic variables):
 - a) Set the date and time for the first entry in the historian log file.
 - b) Set the number of days that the log file will include.
 - c) Select the record type.

Option	Description
1 Second Raw Data	The current values of process and diagnostic variables, recorded at 1-second intervals.
5 Min Average Data	The minimum and maximum values of the 1-second raw data over the last 5 minutes, plus the average and the standard deviation, recorded at 5-minute intervals.

The system provides an estimated file size or transfer time.

4. Specify the location where the log file will be saved.
 - If you are using the display, the log file is written to the USB drive.
 - If you are using ProLink III, the log file is written to a folder on your PC.

The log file is written to the specified location. File names are assigned as follows:

- Historian files: The file name is based on the transmitter tag, the starting date of the log contents, and the record type. The record type is shown as F or S:
 - F=Fast, for 1-second raw data
 - S=Slow, for 5-minute average data
- SMV files:
 - `SmvLast20Data.csv`
 - `SmvLongTermData.csv`
- Totalizer history files: `TotLog.txt`

16.1.1 Historian data and log

The transmitter automatically saves information about specific process and diagnostic variables to its working memory. You can generate a log from this data that tracks all 14 totalizers with 21 days worth of data. The historian log is an ASCII file in `.csv` format.

Contents of the historian log

There are two types of historian records:

- 1-second raw data** The current values of process and diagnostic variables, recorded at 1-second intervals.
- 5-minute average data** The minimum and maximum values of the 1-second raw data, plus the average and the standard deviation, calculated and recorded at 5-minute intervals.

When you generate the log, you can specify which type of record you want to see.

The historian in the transmitter's working memory contains a minimum of 4 weeks of 1-second raw data and 10 years of 5-minute average data.

Each record contains data for the following process and diagnostic variables:

- Timestamp
 - Format: Military time

- Time and time zone: Transmitter clock
- Mass flow rate (kg/sec)
- Volume flow rate (l/sec) or GSV flow rate
- Density (g/cm³)
- Line temperature (°C)
- External temperature (if available)
- Pressure (if available)
- If concentration measurement is enabled:
 - Standard volume flow rate
 - Net mass flow rate
 - Net volume flow rate
 - Referred density
 - Concentration
- If API Referral is enabled:
 - CTPL or CTL
 - Corrected density
 - Corrected volume flow rate
- Alert status registers (hexadecimal format)
- Live zero (kg/sec)
- Tube frequency (Hz)
- Drive gain (%)
- Left pickoff (filtered) (V)
- Right pickoff (filtered) (V)
- Left pickoff (raw) (V)
- Delta T
- Case temperature (°C)
- Voltage applied to the core processor (V)
- Temperature of the core processor board (°C)
- Temperature of the transmitter electronics (°C)

Historian data and power-cycles

Historian data is maintained across transmitter reboots and power-cycles.

Historian data and configuration files

If you restore the factory configuration or upload a configuration file, existing historian data is not affected.

Example: Historian log, 5-minute average data

S TAG:SUPPLY UID:22729F1F SW:000000045 800:000000402	MassFlow	MassFlow	MassFlow	MassFlow	...
DST ON:Mountain GMT-7.0 SM:T075 SN:000000000	kg/s Max	kg/s Min	kg/s Avg	kg/s Std	...
8/25/2020 9:58	0.0082359	0	0.00091223	9.76E-05	...
8/25/2020 10:03	0.001018	0.00084441	0.00091756	1.61E-05	...
8/25/2020 10:08	0.00099489	0.00086279	0.00092519	1.44E-05	...
8/25/2020 10:13	0.0010835	0.00080879	0.00093774	2.01E-05	...
8/25/2020 10:18	0.0011767	0.00084206	0.00094224	2.11E-05	...
8/25/2020 10:23	0.0010243	0.00086888	0.00094534	1.85E-05	...
8/25/2020 10:28	0.0010903	0.00084823	0.00094747	1.81E-05	...
8/25/2020 10:33	0.0010319	0.00085327	0.00095123	1.67E-05	...
8/25/2020 10:38	0.0011232	0.00088614	0.00095222	1.59E-05	...
8/25/2020 10:43	0.0010841	0.00081306	0.00095126	1.99E-05	...
8/25/2020 10:48	0.0010999	0.00086106	0.00095333	1.93E-05	...
8/25/2020 10:53	0.0011523	0.00085537	0.00095528	2.01E-05	...
...					

Note

The historian log displays only in English.

16.1.2 Smart Meter Verification history and log

The transmitter automatically saves test data for all Smart Meter Verification tests. You can generate a log containing data for the 20 most recent tests or for all Smart Meter Verification tests. The log is an ASCII file in `.csv` format.

Contents of Smart Meter Verification log

Each record in the Smart Meter Verification log represents a Smart Meter Verification test. Each record contains the following information:

- Date and time of test
- Data collected during the test
- The abort code (15=test completed normally)
- A pass/fail result for the left pickoff (0=Pass, 1=fail)
- A pass/fail result for the right pickoff (0=Pass, 1=fail)
- The sensor type code
- The sensor serial number

Smart Meter Verification history and power-cycles

If the transmitter is rebooted or power-cycled, Smart Meter Verification history is not affected.

Smart Meter Verification history and configuration files

If you restore the factory configuration or upload a configuration file, Smart Meter Verification history is not affected.

Example: Smart Meter Verification log

Device UID: 577937183

Device Tag: SUPPLY

Time Zone: GMT -7.00

Date Time	LPO Stiff	RPO Stiff	LPO Mass	RPO Mass	Damping	Drv mA	...
8/13/2020 19:27	0.285876	0.289738	0.155294	0.158114	4.41E-05	1.301	...
8/14/2020 7:27	-0.06137	-0.05808	0.154748	0.157556	4.02E-05	1.304	...
8/14/2020 19:27	0.204754	0.20932	0.155185	0.158004	4.35E-05	1.308	...
8/15/2020 7:27	-0.15382	-0.15216	0.154612	0.157416	3.93E-05	1.307	...
8/18/2020 16:27	0.251067	0.251782	0.155217	0.158031	4.34E-05	1.308	...
8/19/2020 19:27	-0.13654	-0.14112	0.154602	0.157396	3.89E-05	1.287	...
8/20/2020 16:27	-0.20837	-0.20671	0.154502	0.157304	3.85E-05	1.291	...
8/21/2020 17:10	-0.11062	-0.11566	0.154641	0.157435	3.84E-05	1.288	...
8/22/2020 10:40	-0.15852	-0.16036	0.154512	0.157308	3.86E-05	1.284	...
8/25/2020 15:40	-0.00172	0.002301	0.154788	0.157599	4E-05	1.295	...
8/27/2020 23:16	0.132787	0.13684	0.155034	0.15785	4.08E-05	1.275	...
8/28/2020 11:16	0.04456	0.046158	0.154845	0.157653	3.99E-05	1.277	...
...							

Note

The Smart Meter Verification log displays only in English.

16.1.3 Totalizer log

The totalizer log can track four configurable totals. The period is configurable; you can configure the transmitter to save totalizer and inventory values at a user-specified interval and then generate a totalizer log. The totalizer log is an ASCII file.

Contents of totalizer log

The totalizer log contains one record for each logged totalizer or inventory value. Each record contains the following information:

- Default totalizer or inventory name (user-specified names are not used)
- Value and measurement unit
- Timestamp

- Format: Military time
- Time and time zone: Transmitter clock

The totalizer log also contains a line item for each totalizer or inventory reset.

Totalizer logs and power cycles

If the transmitter is rebooted or power-cycled, the totalizer log is not affected.

Totalizer logs and configuration files

If you restore the factory configuration or upload a configuration file, the totalizer log is not affected.

Example: Totalizer log

```

=====
Device UID: 22729F1F                               Device Tag: SUPPLY
Name          Value          Units          Time Zone: GMT-7.00
=====
Mass Fwd Total    61.74707    grams          9/12/2020 20:00
Mass Fwd Inv      61.74705    grams          9/12/2020 20:00
Mass Fwd Total    61.74707    grams          9/12/2020 21:00
Mass Fwd Inv      61.74705    grams          9/12/2020 21:00
Mass Fwd Total    61.74707    grams          9/12/2020 22:00
Mass Fwd Inv      61.74705    grams          9/12/2020 22:00
Mass Fwd Total    61.74707    grams          9/12/2020 23:00
Mass Fwd Inv      61.74705    grams          9/12/2020 23:00
Mass Fwd Total    61.74707    grams          9/13/2020 0:00
Mass Fwd Inv      61.74705    grams          9/13/2020 0:00
...

```

Note

The totalizer history displays only in English.

Read contract totals

You can read contract totals for the current 24-hour contract period and for the previous 24-hour contract period. Depending on the configuration of the totalizer log, you may be able to read contract totals for earlier periods.

The contract totals are derived from existing inventories. However, they are reset automatically at the beginning of each contract period. Therefore, the values shown will probably not match the values shown for the inventories.

Important

You can reset inventories manually, and you can stop and start inventories manually. However, if you do this, data for the current contract period will not reflect the entire 24-hour period. Data for earlier contract periods is not affected.

- The contract totals for the current contract period are stored in the **Today's Total [1-4]** parameters.
- The contract totals for the previous contract period are stored in the **Yesterday's Total [1-4]** parameters.
- The contract totals from earlier contract periods can be read in the totalizer log.

Configure contract totals into the totalizer log

The transmitter can be configured to store contract totals to the totalizer log. This allows you to access totals from earlier contract periods. Otherwise, the transmitter maintains data for only the current contract period (today) and the immediately preceding contract period (yesterday).

Procedure

1. Navigate to the **Totalizer Log**.

Option	Description
Display	Menu → Configuration → Totalizer Log
ProLink III	Device Tools → Configuration → Totalizer Log

2. Set **Log Total 1**, **Log Total 2**, **Log Total 3**, and/or **Log Total 4** to the desired contract total.

You can configure the totalizer history log to include both Advanced Phase Measurement and standard totals.

16.2 Generate service files

The transmitter automatically saves several types of service data that is useful in troubleshooting, device maintenance, and administration. You can view the data by generating a service file and downloading it to a USB drive, then using your PC to open the file.

Prerequisites

The service port must be enabled. It is enabled by default. However, if you need to enable it, choose **Menu → Configuration → Security** and set **Service Port** to On.

You must have a USB drive.

Procedure

1.  **WARNING**
If the transmitter is in a hazardous area, do not remove the housing cover while the transmitter is powered up. Failure to follow these instructions can cause an explosion resulting in injury or death.

Open the wiring compartment on the transmitter and insert the USB drive into the service port.

2. Choose **Menu → USB Options → Transmitter → USB → Download Service Files**.
3. Select the service file that you want to generate.

Service file	Description	File name
Configuration Audit Log	All changes to configuration, including changes made by procedures such as zero calibration or density calibration.	ConfigAuditLog.txt

Service file	Description	File name
Alert History	All occurrences of alerts and conditions, independent of alert severity.	AlertLog.txt
Historian: 30 Days	5-minute average values for selected process and diagnostic variables for the last 30 days.	Concatenated from transmitter tag and date
Historian: 1 Day	Values of selected process and diagnostic variables for the last 24 hours, recorded at 1-second intervals.	Concatenated from transmitter tag and date
SMV: 20 Runs	Test data from the 20 most recent SMV tests.	SmvLast20Data.csv
Service Snapshot	An ASCII file containing a snapshot of the transmitter's internal database. This file is used by customer service.	service.dump
Factory Config File	The configuration file created for this transmitter at the factory.	FactoryConfig.cfg
Assert Log	A troubleshooting file used by customer service.	AssertLog.txt
Support Contact	A PDF file containing information for contacting customer service.	SupportContact.pdf
Security Log	A record of events that might indicate tampering.	SecurityLog.txt

- Specify the folder on the USB drive where the log file will be saved.

16.2.1 Alert history and log

The transmitter automatically saves information about all alert occurrences to its working memory, and periodically updates an alert history file on its SD card. The alert history log is an ASCII file.

Contents of alert history

The alert history in the transmitter's working memory contains the 1000 most recent alert records. Each alert record contains the following information:

- Name of alert or condition
- Category:
 - F=Failure
 - FC=Function Check
 - M=Maintenance Required
 - OOS=Out of Specification
 - I=Ignore
- Action:
 - Active=Transition from inactive to active
 - Inactive=Transition from active to inactive
 - Toggling=More than 2 transitions in the last 60 seconds
- Timestamp

- Format: Military time
- Time and time zone: Transmitter clock
- Not displayed if Action=Tooggling

Alert history and power-cycles

If the transmitter is rebooted or power-cycled, the 20 most recent records in alert history are retained in the transmitter's working memory. All earlier records are cleared from working memory. The alert history file on the SD card is not cleared.

Alert history and configuration files

If you restore the factory configuration or upload a configuration file, alert history is not affected.

16.2.2 Configuration audit history and log

The transmitter automatically saves information about all configuration events to its working memory. The configuration audit log is an ASCII file.

Contents of configuration audit log

The configuration audit log contains a record for every change to transmitter configuration, including changes resulting from zero calibration, density calibration, etc. Each record contains:

- Modbus location in transmitter memory
 - *Cnnn* = Coil
 - *Rnnn* = Register
 - *Rnnn xxx* = Array, indexed by register *xxx*
- Name of Modbus location
- Original value
- New value
- Measurement unit, if applicable
- Timestamp
 - Format: Military time
 - Time and time zone: Transmitter clock
- Host or protocol from which the change was made

Configuration audit history and power-cycles

If the transmitter is power-cycled or rebooted, the event is logged in the configuration audit history. Earlier records are not affected.

Configuration audit history and configuration files

If you restore the factory configuration or upload a configuration file, the event is logged in the configuration audit history. Earlier records are not affected.

Example: Configuration audit log

=====

Device UID: 22729F1F

Device Tag: SUPPLY

Addr	Name	Old Value	New Value	Unit	Time Zone: GMT-7:00	Host
C167	SYS_CfgFile_Re	0	1		09/SEP/2019 11:35:11	Display
C167	SYS_CfgFile_Re	0	0		09/SEP/2019 11:35:12	Other
1167	IO_ChannelB_As	10	4		09/SEP/2019 11:35:12	Other
351	SNS_API2540Tab	81	100		09/SEP/2019 11:35:12	Other
40	SNS_DensityUni	91	92		09/SEP/2019 11:35:12	Other
44	SNS_PressureUn	6	12		09/SEP/2019 11:35:12	Other
14	FO_1_Source	0	5		09/SEP/2019 11:35:12	Other
1180	MAI_Source	251	55		09/SEP/2019 11:35:12	Other
275	MAI_mA20Var	0	250.0	°C	09/SEP/2019 11:35:12	Other
4961	FO_2_Source	0	5		09/SEP/2019 11:35:12	Other
68	SYS_Tag	FT-0000	SUPPLY		09/SEP/2019 11:35:12	Other
159	SNS_K1	1606.9	1606.4		09/SEP/2019 11:35:12	Other
161	SNS_K2	1606.9	7354		09/SEP/2019 11:35:12	Other
163	SNS_DensityTem	5.66	4.44		09/SEP/2019 11:35:12	Other
...						

Note

The configuration audit log displays only in English.

16.2.3 Assert history and log

The transmitter automatically saves information about all asserts. You can generate an assert log for use by customer service. The assert log is an ASCII file.

Contents of assert log

The assert history contains the 1000 most recent asserts. An assert is an unusual event in the transmitter firmware that may indicate an error or malfunction. A list of asserts can be useful for troubleshooting by customer service. The assert log is not designed for customer use.

Assert history and power-cycles

Assert history is not affected by reboots or power-cycles.

Assert history and configuration files

If you restore the factory configuration or upload a configuration file, assert history is not affected.

16.2.4 Security log

The transmitter automatically saves data that helps determine if someone is tampering with the device. Counters are maintained to track the number of illegal configuration change requests, firmware upgrade failures, and failures to enter the display password. The security log is an ASCII file.

Contents of security log

The security log contains a summary of security events that have occurred since the last transmitter reboot. The following items are included:

- Device information
- Timestamp
 - Format: Military time
 - Time and time zone: Transmitter clock
- Number of password entry failures
- Number of transmitter firmware upgrade failures
- Number of database write failures

Security log and power-cycles

If the transmitter is rebooted or power-cycled, the security log is not affected.

Security log and configuration files

If you attempt to restore the factory configuration or upload a configuration file when write-protection is enabled, the Database Write Failures counter is increased.

Example: Security log file

```
TAG:SUPPLY      UID:22729F1F    SW:0045                DATE:23/SEP/2019 14:42:58
Device:Config I/O          GMT-7.0 DST:DST Zone:(UTC-7:00) Denver
Addr                Name                Value
```

5851	Password Failures	0
5852	SW Upgrade Failures	0
5853	Database Write Failures	25636

Note

The security log displays only in English.

17 Troubleshooting

17.1 Status LED and device status

The status LED (**MOD STATUS**) on the transmitter display provides a quick indication of device status by changing color and flashing. If the transmitter was ordered without a display, the LEDs on the outputs board inside the transmitter provide the same information.

Table 17-1: Status LED and device status

Status LED condition	Device status
Solid green	No alerts are active.
Solid yellow	One or more alerts are active with Alert Severity = Out of Specification, Maintenance Required, or Function Check.
Solid red	One or more alerts are active with Alert Severity = Failure.
Flashing yellow (1 Hz)	The Function Check in Progress alert is active.

Table 17-2: Network status LED and Ethernet network connection status

Network status LED condition	Network status
Flashing green	No connections made with primary protocol host.
Solid green	Connection made with primary protocol host.
Flashing red	Connection from primary protocol host has timed out.
Solid red	Address Conflict Detection (ACD) algorithm has detected a duplicate IP address.

17.2 Network status LED

The network status LED (**NET STATUS**) on the transmitter display provides a quick indication of the Ethernet network connection status by changing color and flashing.

Table 17-3: Network status LED and Ethernet network connection status

Network status LED condition	Network status
Flashing green	No connections made with primary protocol host.
Solid green	Connection made with primary protocol host.
Flashing red	Connection from primary protocol host has timed out.
Solid red	Address Conflict Detection (ACD) algorithm has detected a duplicate IP address.

17.3 API Referral troubleshooting

17.3.1 Extrapolation alert is active

Cause

Line pressure, line temperature, or line density is outside the range of the configured API table.

Recommended actions

1. Check your process conditions against the values reported by the device.
2. Verify the configuration of the API Referral application and related parameters.

17.3.2 Inaccurate referred density reading

Cause

- Inaccurate density measurement
- Inaccurate temperature measurement
- Incorrect reference conditions
- Incorrect API table selection

Recommended actions

1. Verify the line density value.
2. Verify the line temperature value.
3. Ensure that the application is configured to use the appropriate temperature source.
4. Ensure that the pressure source is configured correctly, that the external pressure device is operating correctly, and that both devices are using the same measurement units.
5. Ensure that reference temperature and reference pressure, if applicable, are configured correctly.
6. Ensure that the selected API table is appropriate for the process fluid.

17.4 Batch troubleshooting

17.4.1 Batch will not start

Cause

- Previous batch not ended
- Valve is closed but the transmitter is detecting flow
- No discrete output configured for batch control

Recommended actions

1. End the batch.
2. Check for two-phase flow.
3. Verify the zero.

4. Verify the cutoffs.
5. Set up a channel to operate as a discrete output, and configure it for batch control.

17.4.2 Valve operation is backwards

Cause

- Discrete Output wiring is incorrect
- Discrete Output polarity is reversed

Recommended actions

1. Verify the wiring between the Discrete Output and the valve. The ON signal must open the valve. Perform a loop test.
2. Change the setting of **Discrete Output Polarity**.

17.4.3 Valve does not operate

Cause

- Discrete Output wiring is incorrect
- Discrete Output channel is set up for internal power

Recommended actions

1. Verify the wiring between the Discrete Output and the valve. The ON signal must open the valve. Perform a loop test.
2. Ensure that the channel is wired and configured for external power.
3. Ensure that the valve and channel are powered.

17.4.4 Batch totals are inaccurate

Cause

- Batch target is incorrect
- AOC is inaccurate
- Flow measurement needs adjustment

Recommended actions

1. Verify that the correct batch preset is active.
2. Verify that the batch target is set correctly.
3. If you have recently changed the batch target, run a few batches and wait for the AOC value to adjust.
4. Repeat AOC calibration.
5. Adjust the fixed AOC value.
6. Compare the batch total to a scale reading.

17.4.5 Batch repeat not satisfactory

Cause

- AOC is inaccurate
- Inconsistent or leaking valve
- Process is unstable

Recommended actions

1. Inspect the valve and replace if necessary.
2. Repeat AOC calibration.
3. Ensure that line pressure is stable.
4. Ensure that bowl level is approximately constant.
5. Ensure that the pump is not causing unstable flow.

17.5 Concentration measurement troubleshooting

17.5.1 Significantly incorrect CM after loading matrix

Cause

The wrong temperature or density unit was configured when the matrix was loaded.

Recommended actions

Set the temperature and density units to the units used when the matrix was built, then reload the matrix.

For custom matrices, contact customer support.

17.5.2 Inaccurate CM reading

Cause

- Inaccurate density measurement
- Inaccurate temperature measurement
- Incorrect reference conditions
- Incorrect matrix data
- Inappropriate trim values

Recommended actions

1. Verify the line density value.
2. Verify the line temperature value.
3. Ensure that the application is configured to use the appropriate temperature source.
4. Ensure that reference temperature is configured correctly.
5. Ensure that the appropriate matrix is active.

6. Ensure that the matrix is configured correctly.
7. Adjust the extrapolation limits for the active matrix.
8. Adjust measurement with a concentration offset trim.

17.6 Alert when connecting a core processor to a remote 5700 transmitter

When connecting a core processor to a 5700, you will see the following alert from the transmitter display.

Alert

New Core Detected

Cause

A new core processor was detected.

Recommended actions

1. Select one of the following options when prompted by the screen.

Option	Description	Action
Core Only Replacement	The new core processor is replacing an old core processor and the sensor is not getting replaced. The core processor is brand new without a baseline and has default factory values, such as K1 = 1000 and K2 = 5000.	Restore configuration and verify sensor parameters.
Pre-Calibrated Core Replacement	The new core processor is pre-calibrated and matched with the sensor. You are replacing a core processor that has already been paired with a sensor that has already been characterized.	Verify the sensor parameters and save the configuration.
Not Pre-Calibrated Core Replacement	The core processor and sensor are being replaced, but the core processor has not been pre-calibrated or matched with the sensor. The sensor and core processor are being replaced but the new core processor has not been paired (characterized) with the new sensor.	Enter the sensor parameters and save the configuration.
I Don't Know	You do not know if the new core processor has been pre-calibrated and matched with the sensor.	Verify the sensor parameters and save the configuration if there was a change.

2. Select **Continue**.
3. Per the screen message, contact Micro Motion if you have any questions before you select the **Finished** button.

These screens will not display again until another new core processor has been detected.

17.7 Density measurement troubleshooting

17.7.1 Erratic density reading

Cause

- Normal process noise
- Two-phase flow
- Line pressure too low
- The flow rate is too high for the installation
- Pipe diameter too small
- Contaminants or suspended solids in the process gas
- Contaminants or suspended solids in the process fluid
- Vibration in the pipeline
- Erosion or corrosion

Recommended actions

1. Check your process conditions against the values reported by the device.
2. Increase the density damping value.
3. Decrease the flow rate.
4. Check for two-phase flow.
5. Ensure that line pressure or sample pressure meets installation requirements.
6. Increase back pressure to minimize bubble formation.
7. Minimize vibration in the pipeline.
8. Increase the pipe diameter.
9. Install a flow control method (bypass, flow chamber, expander, etc.).
10. Perform Smart Meter Verification.

17.7.2 Inaccurate density reading

Cause

- Problem with process fluid
- Incorrect density calibration factors
- Wiring problem
- Incorrect grounding

- Two-phase flow
- Plugged or coated sensor tube
- Incorrect sensor orientation
- RTD failure
- Physical characteristics of sensor have changed

Recommended actions

1. Check the wiring between the sensor and the transmitter.
2. Check the grounding of all components.
3. Check your process conditions against the values reported by the device.
4. Ensure that all of the calibration parameters have been entered correctly. See the sensor tag or the calibration sheet for your meter.
5. Check for two-phase flow.
6. If two sensors with similar frequency are too near each other, separate them.
7. Purge the sensor tubes.
8. Perform Smart Meter Verification.

17.7.3 Unusually high density reading

Cause

- Plugged or coated sensor tube
- Incorrect density calibration factors
- Inaccurate temperature measurement
- RTD failure
- In high-frequency meters, erosion, or corrosion
- In low-frequency meters, tube fouling

Recommended actions

1. Ensure that all of the calibration parameters have been entered correctly. See the sensor tag or the calibration sheet for your meter.
2. Purge the sensor tubes.
3. Check for coating in the flow tubes.
4. Perform Smart Meter Verification.

17.7.4 Unusually low density reading

Cause

- Two-phase flow
- Incorrect calibration factors
- In low-frequency meters, erosion or corrosion

Recommended actions

1. Check your process conditions against the values reported by the device.
2. Verify all of the characterization or calibration parameters. See the sensor tag or the calibration sheet for your meter.
3. Check the wiring between the sensor and the transmitter.
4. Check for tube erosion, especially if the process fluid is abrasive.
5. Perform Smart Meter Verification.

17.8 Discrete Input troubleshooting

17.8.1 No Discrete Input

Cause

- Wiring problem
- Problem with external device
- Channel not configured for desired output or input

Recommended actions

1. Verify that the external device is operating correctly.
2. Test the output from the external device.
3. Verify the wiring between the transmitter and the external device.
4. If applicable, ensure that the loop is powered.
5. Verify that the channel is wired and configured as a Discrete Input.

17.8.2 Discrete Input reading reversed

Cause

- Wiring problem
- Incorrect configuration

Recommended actions

1. Verify the wiring between the transmitter and the external device.
2. Check the setting of **Discrete Input Polarity**.

17.9 Discrete Output troubleshooting

17.9.1 No Discrete Output

Cause

- Output not powered
- Wiring problem

- Channel not configured for desired input or output
- Circuit failure

Recommended actions

1. Check the power supply and power supply wiring.
2. Verify the output wiring.
3. Verify that the channel is wired and configured as a Discrete Output.
4. Contact customer service.

17.9.2 Loop test failed

Cause

- Output not powered
- Power supply problem
- Wiring problem
- Circuit failure

Recommended actions

1. Check the power supply and power supply wiring.
2. Verify the output wiring.
3. Contact customer service.

17.9.3 Discrete Output readings reversed

Cause

- Wiring problem
- Configuration does not match wiring

Recommended actions

1. Verify the output wiring.
2. Ensure that **Discrete Output Polarity** is set correctly.

17.10 Flow measurement troubleshooting

17.10.1 Flow rate reported as zero when flow is present

Cause

The process condition is below cutoff.

Recommended action

Verify the cutoffs.

17.10.2 Flow indication at no flow conditions or zero offset

Cause

- Misaligned piping (especially in new installations)
- Open or leaking valve
- Incorrect sensor zero

Recommended actions

1. Verify all of the characterization or calibration parameters.
See the sensor tag or the calibration sheet for your meter.
2. If the reading is not excessively high, review the live zero. You may need to restore the factory zero.
3. Check for open or leaking valves or seals.
4. Check for mounting stress on the sensor (e.g., sensor being used to support piping, misaligned piping).
5. Contact customer service.

17.10.3 Erratic non-zero flow rate at no-flow conditions

Cause

- Leaking valve or seal
- Two-phase flow
- Plugged or coated sensor tube
- Incorrect sensor orientation
- Wiring problem
- Vibration in pipeline at rate close to sensor tube frequency
- Damping value too low
- Mounting stress on sensor

Recommended actions

1. Verify that the sensor orientation is appropriate for your application.
See the installation manual for your sensor.
2. Check the drive gain and the pickoff voltage.
3. If the wiring between the sensor and the transmitter includes a 9-wire segment, verify that the 9-wire cable shields are correctly grounded.
4. Check the wiring between the sensor and the transmitter.
5. For sensors with a junction box, check for moisture in the junction box.
6. Purge the sensor tubes.
7. Check for open or leaking valves or seals.
8. Check for sources of vibration.
9. Verify damping configuration.

10. Verify that the measurement units are configured correctly for your application.
11. Check for two-phase flow.
12. Check for radio frequency interference.
13. Contact customer service.

17.10.4 Erratic non-zero flow rate when flow is steady

Cause

- Two-phase flow
- Damping value too low
- Plugged or coated sensor tube
- Wiring problem
- Problem with receiving device

Recommended actions

1. Verify that the sensor orientation is appropriate for your application.
See the installation manual for your sensor.
2. Check the drive gain and the pickoff voltage.
3. If the wiring between the sensor and the transmitter includes a 9-wire segment, verify that the 9-wire cable shields are correctly grounded.
4. Check for air entrainment, tube fouling, flashing, or tube damage.
5. Check the wiring between the sensor and the transmitter.
6. For sensors with a junction box, check for moisture in the junction box.
7. Purge the sensor tubes.
8. Check for open or leaking valves or seals.
9. Check for sources of vibration.
10. Verify damping configuration.
11. Verify that the measurement units are configured correctly for your application.
12. Check for two-phase flow.
13. Check for radio frequency interference.
14. Contact customer service.

17.10.5 Inaccurate flow rate

Cause

- Wiring problem
- Inappropriate measurement unit
- Incorrect flow calibration factor
- Incorrect meter factor
- Incorrect density calibration factors

- Incorrect grounding
- Two-phase flow
- Problem with receiving device
- Incorrect sensor zero

Recommended actions

1. Check the wiring between the sensor and the transmitter.
2. Verify that the measurement units are configured correctly for your application.
3. Verify all of the characterization or calibration parameters. See the sensor tag or the calibration sheet for your meter.
4. Zero the meter.
5. Check the grounding of all components.
6. Check for two-phase flow.
7. Verify the receiving device, and the wiring between the transmitter and the receiving device.
8. Check the sensor coils for electrical shorts. If you find problems, replace the sensor.
9. Replace the core processor or transmitter.

17.11 Frequency Output troubleshooting

17.11.1 No FO

Cause

- Stopped totalizer
- Process condition below cutoff
- Fault condition if **Fault Action** is set to Internal Zero or Downscale
- Two-phase flow
- Flow in reverse direction from configured flow direction parameter
- **Frequency Output Direction** not set correctly
- Bad frequency receiving device
- Output level not compatible with receiving device
- Bad output circuit
- Incorrect internal/external power configuration
- Output not powered
- Wiring problem
- Channel not configured for desired output

Recommended actions

1. Verify that the process conditions are below the low-flow cutoff. Reconfigure the low-flow cutoff if necessary.

2. Check the **Fault Action** settings.
3. Verify that the totalizers are not stopped. A stopped totalizer will cause the Frequency Output to be locked.
4. Check for two-phase flow.
5. Check flow direction.
6. Check the direction parameters.
7. Verify the receiving device, and the wiring between the transmitter and the receiving device.
8. Verify that the channel is wired and configured as a Frequency Output.
9. Perform a loop test.

17.11.2 Consistently incorrect FO measurement

Cause

- Output not scaled correctly
- Incorrect measurement unit configured for process variable

Recommended actions

1. Check the scaling of the Frequency Output.
2. Verify that the measurement units are configured correctly for your application.

17.11.3 Erratic FO

Cause

There is Radio Frequency Interference (RFI) from the environment.

Recommended action

Check for radio frequency interference.

17.11.4 FO goes in and out of fault conditions

Cause

There is a problem with the interaction between the Output Saturated alert and the fault action configured for the output.

Recommended actions

1. Change the severity of the Output Saturated alert from Fault to another option.
2. Configure the transmitter to ignore the Output Saturated alert or the relevant conditions.
3. Change the configuration of **Fault Action** from Downscale to another option.

17.12 mA Output troubleshooting

17.12.1 No mA

Cause

- Output not powered
- Power supply problem
- Wiring problem
- Circuit failure

Recommended actions

1. If applicable, check the output wiring to verify that the output is powered.
2. Check the power supply and power supply wiring.
3. Verify the output wiring.
4. Check the **Fault Action** settings.
5. Verify channel configuration for the affected mA Output.
6. Measure DC voltage across output terminals to verify that the output is active.
7. Contact customer service.

17.12.2 Loop test failed

Cause

- Output not powered
- Power supply problem
- Wiring problem
- Circuit failure

Recommended actions

1. Check the power supply and power supply wiring.
2. Verify the output wiring.
3. Check the **Fault Action** settings.
4. Verify channel configuration for the affected mA Output.
5. Contact customer service.

17.12.3 mA below 4 mA

Cause

- Incorrect internal/external power configuration
- Output not powered
- Open in wiring

- Bad output circuit
- Process condition below LRV
- LRV and URV are not set correctly
- Fault condition if **Fault Action** is set to Internal Zero or Downscale
- Bad mA receiving device

Recommended actions

1. Check your process conditions against the values reported by the device.
2. Verify the receiving device, and the wiring between the transmitter and the receiving device.
3. Check the settings of **Upper Range Value** and **Lower Range Value**.
4. Check the **Fault Action** settings.
5. Verify channel configuration for the affected mA Output.

17.12.4 Constant mA0

Cause

- Incorrect process variable assigned to the output
- Fault condition exists
- A loop test is in progress
- Zero calibration failure
- mA Output Direction not set correctly

Recommended actions

1. Verify the output variable assignments.
2. View and resolve any existing alert conditions.
3. Check the direction parameters.
4. Check to see if a loop test is in process (the output is fixed).
5. If related to a zero calibration failure, reboot or power-cycle the transmitter and retry the zeroing procedure.

17.12.5 mA0 consistently out of range

Cause

- Incorrect process variable or units assigned to output
- Fault condition if **Fault Action** is set to Upscale or Downscale
- LRV and URV are not set correctly

Recommended actions

1. Verify the output variable assignments.
2. Verify the measurement units configured for the output.

3. Check the **Fault Action** settings.
4. Check the settings of **Upper Range Value** and **Lower Range Value**.
5. Check the mA Output trim.

17.12.6 Consistently incorrect mA measurement

Cause

- Loop problem
- Output not trimmed correctly
- Incorrect measurement unit configured for process variable
- Incorrect process variable configured
- LRV and URV are not set correctly
- mA Output Direction not set correctly

Recommended actions

1. Check the mA Output trim.
2. Verify the measurement units configured for the output.
3. Verify the process variable assigned to the mA Output.
4. Check the direction parameters.
5. Check the settings of **Upper Range Value** and **Lower Range Value**.

17.12.7 mA correct at lower current, but incorrect at higher current

Cause

The mA loop resistance may be set too high.

Recommended actions

Verify that the mA Output load resistance is below the maximum supported load.
See the installation manual for your transmitter.

17.12.8 mA goes in and out of fault conditions

Cause

There is a problem with the interaction between the Output Saturated alert and the fault action configured for the output.

Recommended actions

1. Change the severity of the Output Saturated alert from Fault to another option.
2. Configure the transmitter to ignore the Output Saturated alert or the relevant conditions.
3. Change the configuration of **Fault Action** from Downscale to another option.

17.13 Status alerts, causes, and recommendations

Not all of these alerts may apply to your type of transmitter.

17.13.1 [002] RAM Error (Core Processor)

Alert

Electronics Failed

Cause

There is an internal memory problem with the core processor. This alert will not clear until you reboot or power cycle the transmitter.

Recommended actions

1. Ensure that all wiring compartment covers are installed correctly.
2. Ensure that all transmitter wiring meets specifications and that all cable shields are properly terminated.
3. Check the drain wires.
4. Check the drain wires.
 - a) Verify that the drain wires from the 4-wire cable are properly landed.
 - b) Verify that the drain wires are landed outside the core processor housing.
 - c) If the drain wires are landed inside the core processor housing, cover them by the foil shield for their full length until they land under the ground screw.
5. Ensure that all meter components are grounded properly.
6. Evaluate the environment for sources of high electromagnetic interference (EMI) and relocate the transmitter or wiring as necessary.
7. Reboot or power-cycle the transmitter to see if the alert clears.
8. Replace the core processor.

17.13.2 [003] Sensor Failed

Alert

Sensor Failed

Cause

The pickoff amplitude is too low.

Recommended actions

1. Check the drive gain and the pickoff voltage.
2. Check the wiring between the sensor and the transmitter.
3. Check the sensor coils for electrical shorts. If you find problems, replace the sensor. Refer to [Check for internal electrical problems](#).
4. Check the integrity of the sensor tubes.

5. Ensure that the sensor is completely full or completely empty.
6. Replace the sensor.
7. Contact customer service.

17.13.3 [005] Mass Flow Rate Overrange

Alert

Extreme Primary Purpose Variable

Cause

The measured flow is outside the sensor's flow limits.

Recommended actions

1. Check your process conditions against the values reported by the device.
2. Verify that the transmitter is configured correctly for the connected sensor.
3. Check for two-phase flow.
Refer to [Check for two-phase flow \(slug flow\)](#).
4. Contact customer service.

17.13.4 [008] Density Overrange

Alert

Extreme Primary Purpose Variable

Cause

The measured density is above 10 g/cm³.

Recommended actions

1. If other alerts are present, resolve those alert conditions first.
2. Check your process conditions against the values reported by the device.
3. Verify that the transmitter is configured correctly for the connected sensor.
4. Check for two-phase flow by checking for two-phase alerts. If two-phase flow is the problem, alerts will be posted.
5. Verify all of the characterization or calibration parameters.
See the sensor tag or the calibration sheet for your meter.
6. Check the sensor coils for electrical shorts. If you find problems, replace the sensor.
7. Check the drive gain and the pickoff voltage.
8. Perform Smart Meter Verification.
9. Contact customer service.

17.13.5 [009] Transmitter Initializing/ Warming Up

Alert

Transmitter Initializing

Cause

The transmitter is in power-up mode.

Recommended actions

1. Allow the meter to complete its power-up sequence. The alert should clear automatically.
2. If the alert does not clear:
 - a) Measure the voltage at the core processor terminals and ensure that it is receiving a minimum of 11.5 volts at all times. If it is not, verify the power wiring to the transmitter.
 - b) Verify that the tubes are full of process fluid.
 - c) Check the wiring between the sensor and the transmitter.

17.13.6 [010] Calibration Failed

Alert

Function Check Failed or Smart Meter Verification Aborted

Cause

The calibration failed.

Recommended actions

1. Ensure that your calibration procedure meets the documented requirements.
2. Reboot or power-cycle the transmitter.
3. Retry the procedure.

17.13.7 [016] Sensor Temperature (RTD) Failure

Alert

Sensor Failed

Cause

The value computed for the resistance of the line RTD is outside limits.

Recommended actions

1. Check the wiring between the sensor and the transmitter.
 - a) Refer to the installation manual and ensure that the wiring has been performed according to instructions. Obey all applicable safety messages.
 - b) Verify that the wires are making good contact with the terminals.

- c) Perform RTD resistance checks and check for shorts to case. If you find problems, replace the sensor.
 - d) Check the continuity of all wires from the transmitter to the sensor.
2. Check your process conditions against the values reported by the device.
3. Check the feedthrough pins. Contact customer service for assistance. If you find problems, replace the sensor.
4. Check the core processor housing for moisture, corrosion, or verdigris.
5. Check the junction box for moisture, corrosion, or verdigris.
6. Contact customer service.

17.13.8 [017] Sensor Case Temperature (RTD) Failure

Alert

Sensor Failed

Cause

The values computed for the resistance of the meter and case RTDs are outside limits.

Recommended actions

1. Check the wiring between the sensor and the transmitter.
 - a) Refer to the installation manual and ensure that the wiring has been performed according to instructions. Obey all applicable safety messages.
 - b) Verify that the wires are making good contact with the terminals.
 - c) Perform RTD resistance checks and check for shorts to case. If you find problems, replace the sensor.
 - d) Check the continuity of all wires from the transmitter to the sensor.
2. Check your process conditions against the values reported by the device.
3. Contact customer service.

17.13.9 [018] EEPROM Error (Transmitter)

Alert

Electronics Failed

Cause

There is an internal memory problem with the transmitter.

Recommended actions

1. Ensure that all wiring compartment covers are installed correctly.
2. Ensure that all transmitter wiring meets specifications and that all cable shields are properly terminated.
3. Check the drain wires.

- a) Verify that the drain wires from the 4-wire cable are properly landed.
 - b) Verify that the drain wires are landed outside the core processor housing.
 - c) If the drain wires are landed inside the core processor housing, cover them by the foil shield for their full length until they land under the ground screw.
4. Ensure that all meter components are grounded properly.
 5. Evaluate the environment for sources of high electromagnetic interference (EMI) and relocate the transmitter or wiring as necessary.
 6. Power-cycle the transmitter to see if the alert clears.

Important

This alert will not clear until you cycle power to the meter.

7. If the alert persists, replace the transmitter.

17.13.10 [019] RAM Error (Transmitter)

Alert

Electronics Failed

Cause

There is a ROM checksum mismatch in the transmitter or the RAM address location cannot be written in the transmitter. This alert will not clear until you reboot or power cycle the transmitter.

Recommended actions

1. Ensure that all wiring compartment covers are installed correctly.
2. Ensure that all transmitter wiring meets specifications and that all cable shields are properly terminated.
3. Check the drain wires.
 - a) Verify that the drain wires from the 4-wire cable are properly landed.
 - b) Verify that the drain wires are landed outside the core processor housing.
 - c) If the drain wires are landed inside the core processor housing, cover them by the foil shield for their full length until they land under the ground screw.
4. Ensure that all meter components are grounded properly.
5. Evaluate the environment for sources of high electromagnetic interference (EMI) and relocate the transmitter or wiring as necessary.
6. Reboot or power-cycle the transmitter to see if the alert clears.
7. If the alert persists, replace the transmitter.

17.13.11 [020] Calibration Factors Missing

Alert

Configuration Error

Cause

Some calibration factors have not been entered or are incorrect.

Recommended actions

1. Verify characterization parameters (specifically Flow Cal Factor and K1 values). Refer to [Characterize the meter \(if required\)](#).
2. Verify the setting of the **Sensor Type** parameter.
3. If **Sensor Type** = Curved Tube, ensure that no parameters specific to Straight Tube have been set.
4. Check the feedthrough pins. If you find problems, replace the sensor.
Contact customer service for assistance.
5. Check the core processor housing for moisture, corrosion, or verdigris.
6. Check the junction box for moisture, corrosion, or verdigris.
7. Check the sensor coils for electrical shorts. If you find problems, replace the sensor.

17.13.12 [021] Incorrect Sensor Type

Alert

Configuration Error

Cause

Transmitter verification of sensor circuits and characterization has produced a discrepancy. The transmitter cannot operate the sensor.

Recommended actions

1. Verify the setting of the **Sensor Type** parameter.
2. Verify characterization parameters (specifically Flow Cal Factor and K1 values). Refer to [Characterize the meter \(if required\)](#).
3. Contact customer service.

17.13.13 [022] Configuration Database Corrupt

Alert

Electronics Failed

Cause

There is a NVM checksum mismatch in the core processor's configuration memory. This alert applies to the standard core processor only.

Recommended actions

1. Ensure that all wiring compartment covers are installed correctly.
2. Ensure that all transmitter wiring meets specifications and that all cable shields are properly terminated.
3. Check the drain wires.
 - a) Verify that the drain wires from the 4-wire cable are properly landed.

- b) Verify that the drain wires are landed outside the core processor housing.
 - c) If the drain wires are landed inside the core processor housing, cover them by the foil shield for their full length until they land under the ground screw.
4. Ensure that all meter components are grounded properly.
 5. Evaluate the environment for sources of high electromagnetic interference (EMI) and relocate the transmitter or wiring as necessary.
 6. Reboot or power-cycle the transmitter to see if the alert clears.
 7. If the alert persists, replace the core processor.

17.13.14 [024] Program Corrupt (Core Processor)

Alert

Electronics Failed

Cause

There is a checksum mismatch in the core processor's program section. This alert applies to the standard core processor only.

Recommended actions

1. Ensure that all wiring compartment covers are installed correctly.
2. Ensure that all transmitter wiring meets specifications and that all cable shields are properly terminated.
3. Check the drain wires.
 - a) Verify that the drain wires from the 4-wire cable are properly landed.
 - b) Verify that the drain wires are landed outside the core processor housing.
 - c) If the drain wires are landed inside the core processor housing, cover them by the foil shield for their full length until they land under the ground screw.
4. Ensure that all meter components are grounded properly.
5. Evaluate the environment for sources of high electromagnetic interference (EMI) and relocate the transmitter or wiring as necessary.
6. Reboot or power-cycle the transmitter to see if the alert clears.
7. If the alert persists, replace the core processor.

17.13.15 [026] Sensor/Transmitter Communications Failure

Alert

Sensor-Transmitter Communication Error

Cause

The transmitter has lost communication with the core processor, or there have been too many communications errors.

Recommended actions

1. Check the wiring between the sensor and the transmitter.
2. Verify the power to both the transmitter and core processor.
3. Cycle power to the transmitter.
4. If the alert persists:
 - a) Replace the core processor.
 - b) If that does not solve the problem, restore the original core processor and replace the transmitter.
 - c) If that does not solve the problem, replace both the transmitter and the core processor.
5. If the problem persists, contact customer support.

17.13.16 [027] Security Breach

Alert

Security Breach

Cause

The transmitter is not secured.

Recommended actions

Secure the transmitter.

17.13.17 [028] Core Process Write Failure

Alert

Sensor-Transmitter Communication Error

Cause

A write to the core processor failed.

Recommended actions

1. Reboot or power-cycle the transmitter to see if the alert clears.
2. Contact customer service about servicing or replacing the core processor or transmitter.

17.13.18 [030] Incorrect Board Type

Alert

Configuration Error

Cause

The firmware or configuration loaded in the transmitter is incompatible with the board type.

Recommended actions

1. Ensure that the correct board is installed.
2. If this alarm occurred in conjunction with an effort to load a configuration into the transmitter, confirm that the transmitter is of the same model as the one the configuration came from.
3. Reboot or power-cycle the transmitter to see if the alert clears.
4. If the alert persists, replace the transmitter.
5. If the problem persists, contact customer service.

17.13.19 [031] Low Power

Alert

Core Low Power

Cause

The enhanced core processor is not receiving sufficient power. This alert will not clear until you reboot or power cycle the transmitter.

Recommended actions

1. Check the wiring between the sensor and the transmitter.
2. Measure the voltage at the core processor terminals and ensure that it is receiving a minimum of 11.5 volts at all times. If it is not, verify the power wiring to the transmitter.
3. Verify that the transmitter is receiving sufficient power.
 - a) If it is not, correct the problem and reboot or power-cycle the transmitter.
 - b) If it is, this suggests that the transmitter has an internal power issue. Replace the transmitter.

17.13.20 [033] Insufficient Pickoff Signal

Alert

Tube Not Full

Cause

The signal from the sensor pickoffs is insufficient for operation (enhanced core processor only).

Recommended actions

1. Check for two-phase flow.
2. Check the sensor tubes for plugging or coating.
3. Check for fluid separation by monitoring the density value and comparing the results against expected density values.
4. Ensure that the sensor orientation is appropriate for your application. Settling from a two-phase or three-phase fluid can cause this alert even if the flow tubes are full.

17.13.21 [034] Smart Meter Verification Failed

Alert

Function Check Failed or Smart Meter Verification Aborted

Cause

The current Smart Meter Verification value is statistically different than the factory baseline value.

Recommended actions

Minimize process instability and repeat the test.

17.13.22 [035] Smart Meter Verification Aborted

Alert

Function Check Failed or Smart Meter Verification Aborted

Cause

The Smart Meter Verification test did not complete, possibly because it was manually aborted or because process conditions were too unstable.

Recommended actions

1. Minimize process instability and repeat the test.
2. Check the Smart Meter Verification abort code and take appropriate steps.
3. Contact customer service.

17.13.23 [102] Drive Overrange

Alert

Drive Over-Range

Cause

The drive power (current/ voltage) is at its maximum.

Recommended actions

1. Check your process conditions against the values reported by the device.
2. Check for air in the flow tubes, tubes not filled, foreign material in the tubes, coating in the tubes, or other process problems.
3. Verify that the tubes are full of process fluid.
4. Check the drive gain and the pickoff voltage.
Refer to [Check the pickoff voltage](#).
5. Check the sensor coils for electrical shorts. If you find problems, replace the sensor.
Refer to [Check for internal electrical problems](#).
6. Ensure that the sensor orientation is appropriate for your application.
Settling from a two-phase or three-phase fluid can cause this alert even if the flow tubes are full.

17.13.24 [103] Configuration Warning

Alert

Configuration Warning

Cause

The core processor was unable to store the totalizer and inventory values on the last power-down, and must rely on the saved totals. (Standard core processor only)

Recommended actions

Verify that the transmitter is receiving sufficient power.

- If it is not, correct the problem and reboot or power-cycle the transmitter.
- If it is, replace the transmitter because the transmitter has an internal power issue.

17.13.25 [104] Calibration in Progress

Alert

Function Check in Progress

Cause

A calibration is running.

Recommended actions

Allow the test to complete.

17.13.26 [105] Two-Phase Flow

Alert

Process Aberration

Cause

The line density is outside the user-defined two-phase flow limits.

Recommended actions

1. Check for two-phase flow.
Refer to [Configure Lower Range Value \(LRV\) and Upper Range Value \(URV\) for the mA Output](#).
2. Verify that the transmitter is configured correctly for the connected sensor.

17.13.27 [110] Frequency Output 1 Saturated

Alert

Output Saturated

Cause

The calculated output value is outside the range of the output.

Recommended actions

1. Check the scaling of the Frequency Output.
2. Check your process conditions against the values reported by the device.
3. Ensure that both devices are using the same measurement unit.
4. Purge the sensor tubes.

17.13.28 [111] Frequency Output 1 Fixed

Alert

Output Fixed

Cause

The output is configured to send a constant value. A loop test may be in progress.

Recommended actions

Check to see if a loop test is in process (the output is fixed).

17.13.29 [116] Temperature Overrange (API Referral)

Alert

Process Aberration

Cause

The line temperature is outside the range of the API table.

Recommended actions

1. Ensure that process temperature is within the range of the API table.
2. Verify the configuration of the API Referral application and related parameters.

17.13.30 [117] Density Overrange (API Referral)

Alert

Process Aberration

Cause

The line density is outside the range of the API table.

Recommended actions

1. Ensure that process density is within the range of the API table.
2. Verify the configuration of the API Referral application and related parameters.

17.13.31 [119] Discrete Output 2 Fixed

Alert

Output Fixed

Cause

The output is set to a constant state. A loop test may be in progress.

Recommended actions

Check to see if a loop test is in process (the output is fixed).

17.13.32 [120] Curve Fit Failure (Concentration)

Alert

Configuration Error

Cause

The transmitter was unable to calculate a valid concentration matrix from the current data.

Recommended actions

1. Verify the configuration of the concentration measurement application.
2. Contact customer service.

17.13.33 [121] Extrapolation Alert (Concentration)

Alert

Process Aberration

Cause

The line density or line temperature is outside the range of the concentration matrix plus the configured extrapolation limit.

Recommended actions

1. Ensure that process density and temperature are within the limits of the concentration matrix.
2. Verify the configuration of the concentration measurement application.

17.13.34 [123] Pressure Overrange (API Referral)

Alert

Process Aberration

Cause

The line pressure is outside the range of the API table.

Recommended actions

1. Ensure that process pressure is within the range of the API table.
2. Verify the configuration of the API Referral application and related parameters.

17.13.35 [131] Smart Meter Verification in Progress

Alert

Function Check in Progress

Cause

A Smart Meter Verification test is running.

Recommended actions

Allow the test to complete.

17.13.36 [132] Sensor Simulation Active

Alert

Sensor Being Simulated

Cause

Sensor simulation mode is enabled (enhanced core processor only).

Recommended actions

Disable sensor simulation.

17.13.37 [138] TBR Active

Alert

Process Aberration

Cause

Drive gain is above the configured threshold and transient bubble remediation is active.

Recommended actions

Check for air entrainment, tube fouling, flashing, or tube damage.

17.13.38 Bad IP network settings

Alert

Configuration Error

Cause

- IF DHCP is enabled, the DHCP server could not be found.

- If DHCP is disabled, there is a mismatch between the IP address, Subnet mask and default gateway settings.

Recommended actions

1. Correct the network settings on the transmitter and/or the PC.
2. If the transmitter is installed on an Ethernet network, contact your network administrator to determine the correct network settings.

17.13.39 Batchers Not Configured

Alert

Configuration Error

Cause

One or more of the following has occurred:

- The batcher application is disabled
- No flow source has been configured for the batcher application
- The batch target is 0
- No Discrete Output is assigned to batch control.

Recommended actions

Verify the configuration of the batcher application and related parameters.

17.13.40 Batch Time Out

Alert

Process Aberration

Cause

The batch exceeded **Maximum Batch Time**, and ended before the target was reached.

Recommended actions

Verify the configuration of the batcher application and related parameters.

17.13.41 Clock Failure

Alert

Data Loss Possible

Cause

The transmitter's real-time clock is not incrementing.

Recommended actions

Contact customer service.

17.13.42 Core Processor Update Failed

Alert

Configuration Error

Cause

The core processor software update failed.

Recommended actions

1. Resolve any active alerts.
2. Check the connection between the transmitter and the core processor.
3. Reboot or power-cycle the transmitter, then retry the procedure.
4. Contact customer service.

17.13.43 Enhanced Event X Active

Alert

Event Active

Cause

The conditions assigned to any enhanced event (Enhanced Event 1 through Enhanced Event 5) are present.

Recommended actions

1. If this is an accurate indication of process conditions, no action is required. The alert will clear when the process returns to normal.
2. Review event configuration if you believe the event was triggered erroneously.

17.13.44 Event X Active

Alert

Event Active

Cause

The conditions assigned to either Basic Event 1 or Basic Event 2 are present.

Recommended actions

1. If this is an accurate indication of process conditions, no action is required. The alert will clear when the process returns to normal.
2. Review event configuration if you believe the event was triggered erroneously.

17.13.45 mA Output 3 Fixed

Alert

Output Fixed

Cause

The output is configured to send a constant value. A loop test may be in progress.

Recommended actions

1. Check to see if a loop test is in process (the output is fixed).
2. Exit mA Output trim, if applicable.

17.13.46 mA Output 3 Saturated

Alert

Output Saturated

Cause

The calculated output value is outside the range of the output.

Recommended actions

1. Check the settings of **Upper Range Value** and **Lower Range Value**.
Refer to [Configure Lower Range Value \(LRV\) and Upper Range Value \(URV\) for the mA Output](#).
2. Check your process conditions against the values reported by the device.
3. Ensure that both devices are using the same measurement unit.
4. Purge the sensor tubes.

17.13.47 Moderate Two Phase Flow

Alert

Process Aberration

Cause

The transmitter has detected moderate two-phase flow.

Recommended actions

Check your process conditions against the values reported by the device.

17.13.48 No Permanent License

Alert

Data Loss Possible

Cause

A permanent license has not been installed in the transmitter firmware.

Recommended actions

1. If you have a permanent license, install it.
2. If you do not have a permanent license, contact customer service.

17.13.49 Paper Out

Cause

A functional check alert is commonly triggered due to the following conditions:

- Incorrect network settings configuration
- Out of paper
- Paper tray is open
- Printer already has six open connections
- Another transmitter tries to start a print while another transmitter is printing

Recommended actions

Check the trigger conditions and correct as needed.

Important

Configuration items and audit log tickets can take more than 15 minutes to print and use up large amounts of paper.

If during this time another transmitter starts a print, the new print may either be rejected, causing a functional check alert (printer offline), or the print will be inserted in the middle of the configuration/audit log print.

The functional check alert is cleared after a successful print.

17.13.50 Password Not Set

Alert

Configuration Error

Cause

Display security has been enabled but the display password has not been changed from the default value.

Recommended actions

Configure a password or disable display security.

17.13.51 SD Card Failure

Alert

Data Loss Possible

Cause

The transmitter's SD card has failed.

Recommended actions

1. Make sure that the SD card is firmly seated in the socket.
2. Contact customer service.

17.13.52 SD Card Full

Alert

Data Loss Possible

Cause

The transmitter's SD card is 90% full.

Recommended actions

Contact customer service.

17.13.53 Severe Two Phase Flow

Alert

Process Aberration

Cause

The transmitter has detected severe two-phase flow.

Recommended actions

Check your process conditions against the values reported by the device.

17.13.54 Time Not Entered

Alert

Configuration Error

Cause

The system time has not been entered. The system time is required for diagnostic logs.

Recommended actions

Set the system time.

17.13.55 Transmitter Software Update Failed

Cause

The transmitter software update failed.

Recommended actions

1. Reboot or power-cycle the transmitter.
2. Retry the procedure.
3. Contact customer service.

17.13.56 Watchdog Error

Alert

Electronics Failed

Cause

The watchdog timer has expired.

Recommended actions

1. Reboot or power-cycle the transmitter to see if the alert clears.
2. If the alert persists, replace the transmitter.
3. Contact customer support.

17.14 Perform a core processor resistance test

This procedure measures the resistance between the core processor terminals in the transmitter junction box. The procedure applies only to 4-wire remote installations and remote core processor with remote transmitter installations.

Note

Although you can perform the same test on the terminals at the core processor, the transmitter junction box is typically easier to access.

Procedure

1. Power down the transmitter.
2. Remove the cover of the junction box on the transmitter to access the core processor terminals.

Figure 17-1: Removing the cover of the junction box

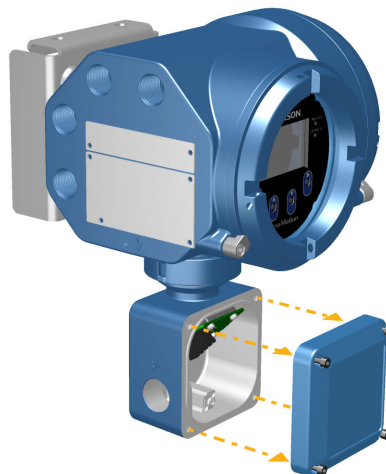

3. Disconnect the 4-wire cable between the transmitter and the sensor.
4. Identify the core processor terminals inside the transmitter junction box.

Figure 17-2: Core processor terminals inside the transmitter junction box

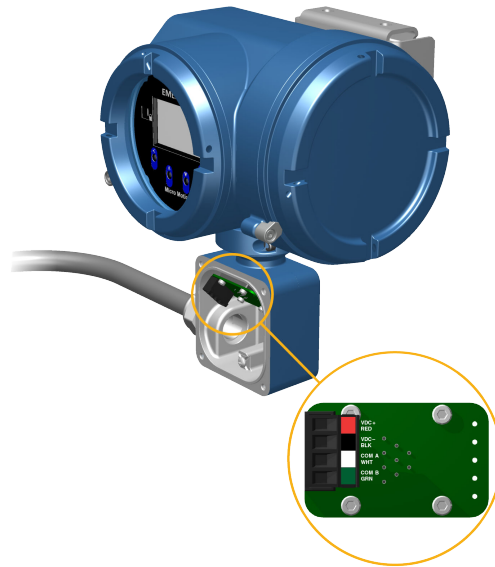

5. For the 700 core processor only, measure the resistance between the terminal pairs listed here.

Terminal pair (transmitter)	Terminal pair (core processor)	Function	Expected resistance
White – green	3–4	RS-485/A and RS-485/B	29 kΩ to 33 kΩ
Black – white	2–3	VDC– and RS-485/A	29 kΩ to 33 kΩ
Black – green	2–4	VDC– and RS-485/B	16 kΩ to 18 kΩ

6. If any resistance measurements are lower than specified, contact customer service.
7. If the resistance measurements fall within the expected ranges, return the transmitter to normal operation and check the wiring between the transmitter and the core processor. If that does not resolve the problem, contact customer service.

Postrequisites

To return to normal operation:

1. Reconnect the 4-wire cable from the sensor to the core processor terminals.
2. Replace the junction box cover.
3. Restore power to the transmitter.

17.15 Check the cutoffs

If the transmitter cutoffs are configured incorrectly, the transmitter may report zero flow when flow is present, or very small amounts of flow under no-flow conditions.

Procedure

Verify the configuration of all cutoffs.

17.16 Check the direction parameters

If the direction parameters are set incorrectly, flow rate may be reported as reverse when it is actually forward, or vice versa. Totalizers and inventories may increment when they should decrement, or vice versa.

The reported flow rate and flow totals depend on the interaction of four factors: the flow direction arrow on the sensor, actual flow direction, the **Sensor Flow Direction Arrow** parameter, the **Direction** parameter for the mA output or the frequency output, and the **Totalizer Direction** parameter.

Procedure

1. Ensure that **Sensor Flow Direction Arrow** is set correctly for your sensor installation and your process.
2. Verify the configuration of **mA Output Direction**, **Frequency Output Direction**, and **Totalizer Direction**.

17.17 Check the drive gain

Excessive or erratic drive gain may indicate any of a variety of process conditions or sensor problems.

To know whether your drive gain is excessive or erratic, you must collect drive gain data during the problem condition and compare it to drive gain data from a period of normal operation.

Excessive (saturated) drive gain

Table 17-4: Possible causes and recommended actions for excessive (saturated) drive gain

Possible cause	Recommended actions
Bent sensor tube	Check the pickoff voltages (see Check the pickoff voltage). If either of them are close to zero (but neither is zero), the sensor tubes may be bent. The sensor will need to be replaced.
Cracked sensor tube	Replace the sensor.
Core processor or module failure	Contact customer support.
Flow rate out of range	Ensure that the flow rate is within sensor limits.
Open drive or pickoff sensor coil	Contact customer support.
Over-pressurized tubes	Contact customer support.
Plugged sensor tube	A dull, audible hum, and unusually high sensor vibration is usually accompanied by high, even saturated, drive gain. Check the pickoff voltages (see Check the pickoff voltage). If either of them are close to zero (but neither is zero), plugged tubes may be the source of your problem. Purge the tubes. In extreme cases, you may need to replace the sensor.

Table 17-4: Possible causes and recommended actions for excessive (saturated) drive gain (continued)

Possible cause	Recommended actions
Sensor case full of process fluid	Replace the sensor.
Sensor imbalance	Contact customer support.
Sensor tubes not completely full	Correct process conditions so that the sensor tubes are full.
Two-phase flow	Check for two-phase flow. See Check for two-phase flow (slug flow) .
Vibrating element not free to vibrate	Ensure that the vibrating element is free to vibrate.

Erratic drive gain

Table 17-5: Possible causes and recommended actions for erratic drive gain

Possible cause	Recommended actions
Foreign material caught in sensor tubes	<ul style="list-style-type: none"> Purge the sensor tubes. Replace the sensor.

17.18 Check for internal electrical problems

Shorts between sensor terminals or between the sensor terminals and the sensor case can cause the sensor to stop working.

Possible cause	Recommended action
Moisture inside the sensor junction box	Ensure that the junction box is dry and no corrosion is present.
Liquid or moisture inside the sensor case	Contact customer support.
Internally shorted feedthrough	Contact customer support.
Faulty cable	Replace the cable.
Improper wire termination	Verify wire terminations inside the sensor junction box. See <i>Micro Motion 9-Wire Flow Meter Cable Preparation and Installation Guide</i> .
Shorts to the housing created by trapped or damaged wires	Contact customer support.
Loose wires or connectors	Contact customer support.
Liquid or moisture inside the housing	Contact customer support.

17.19 Check Frequency Output Fault Action

The **Frequency Output Fault Action** controls the behavior of the Frequency Output if the transmitter encounters an internal fault condition. If the Frequency Output is reporting a constant value, the transmitter may be in a fault condition.

Procedure

1. Check the status alerts for active fault conditions.
2. If there are active fault conditions, the transmitter is performing correctly. If you want to change its behavior, change the setting of **Frequency Output Fault Action**.
3. If there are no active fault conditions, continue troubleshooting.

17.20 Check the scaling of the Frequency Output

If the process variable assigned to the Frequency Output goes to a value that would set the Frequency Output to a signal below 0 Hz or above 12500 Hz, the meter will post an Output Saturated alert for the affected output, then perform the configured fault action.

Procedure

1. Record your current process conditions.
2. Adjust the scaling of the Frequency Output.

17.21 Check grounding

A sensor and the transmitter must be grounded.

Prerequisites

You will need an:

- Installation manual for your sensor
- Installation manual for your transmitter (remote-mount installations only)

Procedure

Refer to the sensor and transmitter installation manuals for grounding requirements and instructions.

17.22 Perform loop tests

A loop test is a way to verify that the transmitter and the remote device are communicating properly. A loop test also helps you know whether you need to trim mA Outputs.

Prerequisites

- Before performing a loop test, configure the channels for the transmitter inputs and outputs that will be used in your application.
- Follow appropriate procedures to ensure that loop testing will not interfere with existing measurement and control loops.

17.22.1 Perform a mA loop test using the display

Prerequisites

Before performing an mA loop test, configure Channel C as an mA Output.

Follow appropriate procedures to ensure that loop testing will not interfere with existing measurement and control loops.

Procedure

1. Choose **Menu** → **Service Tools** → **Output Simulation** and select the mA Output.
2. Set **Simulation Value** to 4.
3. Start the simulation.
4. Read the mA current at the receiving device and compare it to the transmitter output.
The readings do not need to match exactly. If the values are slightly different, you can correct the discrepancy by trimming the output.
5. Choose **New Value**.
6. Set **Simulation Value** to 20.
7. Start the simulation.
8. Read the mA current at the receiving device and compare it to the transmitter output.
The readings do not need to match exactly. If the values are slightly different, you can correct the discrepancy by trimming the output.
9. Choose **Exit**.

Postrequisites

- If the mA Output readings are within 200 microamps of each other, you can correct this discrepancy by trimming the output.
- If the discrepancy between the mA Output readings is greater than 200 microamps, or if at any step the reading was faulty, verify the wiring between the transmitter and the remote device, and try again.

17.22.2 Perform a Frequency Output loop test using the display

Prerequisites

Before performing a Frequency Output loop test, configure Channel C as a Frequency Output.

Follow appropriate procedures to ensure that loop testing will not interfere with existing measurement and control loops.

Procedure

1. Choose **Menu** → **Service Tools** → **Output Simulation** and select the Frequency Output.
2. Set **Simulation Value** to 1.
3. Start the simulation.
4. Read the frequency signal at the receiving device and compare it to the transmitter output.
5. Choose **New Value**.
6. Set **Simulation Value** to 14500.

7. Start the simulation.
8. Read the frequency signal at the receiving device and compare it to the transmitter output.
9. Choose **Exit**.

17.22.3 Perform a Discrete Output loop test using the display

Prerequisites

Before performing a Discrete Output loop test, configure Channel C as a Discrete Output.

Follow appropriate procedures to ensure that loop testing will not interfere with existing measurement and control loops.

Procedure

1. Choose **Menu** → **Service Tools** → **Output Simulator** and select the Discrete Output.
2. Set **Simulation Value** to ON.
3. Start the simulation.
4. Verify the signal at the receiving device.
5. Choose **New Value**.
6. Set **Simulation Value** to OFF.
7. Start the simulation.
8. Verify the signal at the receiving device.
9. Choose **Exit**.

Postrequisites

If the Discrete Output readings are reversed, check the setting of **Discrete Output Polarity**.

17.22.4 Perform a Discrete Input loop test using the display

Prerequisites

Before performing a Discrete Input loop test, configure Channel C for a Discrete Input.

Follow appropriate procedures to ensure that loop testing will not interfere with existing measurement and control loops.

Procedure

1. Set the remote input device to ON.
2. Choose **Menu** → **Service Tools** → **Service Data** → **View I/O Levels** and read the state of the Discrete Input.
3. Set the remote input device to OFF.
4. Choose **Menu** → **Service Tools** → **Service Data** → **View I/O Levels** and read the state of the Discrete Input.
5. Return the remote input device to normal operation.

Postrequisites

If the Discrete Input readings are reversed, check the setting of **Discrete Input Polarity**.

17.22.5 Perform an mA loop test using ProLink III

Prerequisites

Before performing an mA loop test, configure Channel C as an mA Output.

Follow appropriate procedures to ensure that loop testing will not interfere with existing measurement and control loops.

Procedure

1. Choose **Device Tools** → **Diagnostics** → **Testing** and select the mA Output to test.
2. Enter 4 in **Fix to:**.
3. Select **Fix mA**.
4. Read the mA current at the receiving device and compare it to the transmitter output.
The readings do not need to match exactly. If the values are slightly different, you can correct the discrepancy by trimming the output.
5. Select **UnFix mA**.
6. Enter 20 in **Fix to:**.
7. Select **Fix mA**.
8. Read the mA current at the receiving device and compare it to the transmitter output.
The readings do not need to match exactly. If the values are slightly different, you can correct the discrepancy by trimming the output.
9. Select **UnFix mA**.

Postrequisites

- If the mA Output readings are within 200 microamps of each other, you can correct this discrepancy by trimming the output.
- If the discrepancy between the mA Output readings is greater than 200 microamps, or if at any step the reading was faulty, verify the wiring between the transmitter and the remote device, and try again.

17.22.6 Perform a Frequency Output loop test using ProLink III

Prerequisites

Before performing a Frequency Output loop test, configure Channel C as a Frequency Output.

Follow appropriate procedures to ensure that loop testing will not interfere with existing measurement and control loops.

Procedure

1. Choose **Device Tools** → **Diagnostics** → **Testing** and select the Frequency Output to test.
2. Enter the Frequency Output value in **Fix to**.
3. Select **Fix FO**.
4. Read the frequency signal at the receiving device and compare it to the transmitter output.
5. Select **UnFix FO**.

17.22.7 Perform a Discrete Output loop tests using ProLink III

Prerequisites

Before performing a Discrete Output loop test, configure Channel C as a Discrete Output.

Follow appropriate procedures to ensure that loop testing will not interfere with existing measurement and control loops.

Procedure

1. Choose **Device Tools** → **Diagnostics** → **Testing** → **Discrete Output Test**.
2. If your transmitter is configured for two or more Discrete Outputs, determine which Discrete Output you want to test.
3. Set **Fix To:** to ON.
4. Verify the signal at the receiving device.
5. Set **Fix To:** to OFF.
6. Verify the signal at the receiving device.
7. Select **UnFix**.

Postrequisites

If the Discrete Output readings are reversed, check the setting of **Discrete Output Polarity**.

17.22.8 Perform a Discrete Input loop test using ProLink III

Prerequisites

Before performing a Discrete Input loop test, configure Channel C for a Discrete Input.

Follow appropriate procedures to ensure that loop testing will not interfere with existing measurement and control loops.

Procedure

1. Set the remote input device to ON.
2. Choose **Device Tools** → **Diagnostics** → **Testing** → **Discrete Input Test**.
3. Verify the signal at the transmitter.
4. Set the remote input device to OFF.
5. Verify the signal at the transmitter.

Postrequisites

If the Discrete Input readings are reversed, check the setting of **Discrete Input Polarity**.

17.22.9 Perform an mA loop test using a web browser

Prerequisites

Before performing an mA loop test, configure Channel C as an mA Output.

Follow appropriate procedures to ensure that loop testing will not interfere with existing measurement and control loops.

Procedure

1. Choose **Device Tools** → **Simulation** → **mA Output Test**.
2. Enter 4 in **Fix to:**.
3. Select **Fix mA**.
4. Read the mA current at the receiving device and compare it to the transmitter output.
The readings do not need to match exactly. If the values are slightly different, you can correct the discrepancy by trimming the output.
5. Select **UnFix mA**.
6. Enter 20 in **Fix to:**.
7. Select **Fix mA**.
8. Read the mA current at the receiving device and compare it to the transmitter output.
The readings do not need to match exactly. If the values are slightly different, you can correct the discrepancy by trimming the output.
9. Select **UnFix mA**.

Postrequisites

- If the mA Output readings are within 200 microamps of each other, you can correct this discrepancy by trimming the output.
- If the discrepancy between the mA Output readings is greater than 200 microamps, or if at any step the reading was faulty, verify the wiring between the transmitter and the remote device, and try again.

17.22.10 Perform a Frequency Output loop test using a web browser

Prerequisites

Before performing a Frequency Output loop test, configure Channel C as a Frequency Output.

Follow appropriate procedures to ensure that loop testing will not interfere with existing measurement and control loops.

Procedure

1. Choose **Service Tools** → **Simulation** → **Frequency Output Test**.
2. Enter the Frequency Output value in **Fix to**.
3. Select **Fix FO**.
4. Read the frequency signal at the receiving device and compare it to the transmitter output.
5. Select **UnFix FO**.

17.22.11 Perform a Discrete Output loop test using a web browser

Prerequisites

Before performing a Discrete Output loop test, configure Channel C as a Discrete Output.

Follow appropriate procedures to ensure that loop testing will not interfere with existing measurement and control loops.

Procedure

1. Choose **Service Tools** → **Simulation** → **Discrete Output Test**.
2. Set **Fix To:** to ON.
3. Verify the signal at the receiving device.
4. Set **Fix To:** to OFF.
5. Verify the signal at the receiving device.
6. Select **UnFix**.

Postrequisites

If the Discrete Output readings are reversed, check the setting of **Discrete Output Polarity**.

17.22.12 Perform a Discrete Input loop test using a web browser

Prerequisites

Before performing a Discrete Input loop test, configure Channel C for a Discrete Input.

Follow appropriate procedures to ensure that loop testing will not interfere with existing measurement and control loops.

Procedure

1. Set the remote input device to ON.
2. Choose **Service Tools** → **Diagnostics** → **View I/O Levels**.
3. Verify the **Channel C Value** accurately shows the input.
4. Set the remote input device to OFF.
5. Verify the **Channel C Value** accurately shows the input.

Postrequisites

- If the Discrete Input readings are reversed, check the setting of **Discrete Input Polarity**.

17.23 Check Lower Range Value and Upper Range Value

If the process variable assigned to the mA Output falls below the configured **Lower Range Value** (LRV) or rises above the configured **Upper Range Value** (URV), the meter will post an Output Saturated alert for the affected output, then perform the configured fault action.

Procedure

1. Record your current process conditions.
2. Check the configuration of the LRV and URV.

17.24 Check mA Output Fault Action

The **mA Output Fault Action** controls the behavior of the mA Output if the transmitter encounters an internal fault condition. If the mA Output is reporting a constant value below 4 mA or above 20 mA, the transmitter may be in a fault condition.

Procedure

1. Check the status alerts for active fault conditions.
2. If there are active fault conditions, the transmitter is performing correctly. If you want to change its behavior, change the setting of **mA Output Fault Action**.
3. If there are no active fault conditions, continue troubleshooting.

17.25 Trim mA Output

Trimming an mA Output calibrates the transmitter's mA Output to the receiving device. If the current trim value is inaccurate, the transmitter will under-compensate or over-compensate the output.

17.25.1 Trim an mA Output using the display

Trimming the mA Output establishes a common measurement range between the transmitter and the device that receives the mA Output.

Prerequisites

Ensure that the mA Output is wired to the receiving device that will be used in production.

Procedure

1. Choose **Menu** → **Service Tools** → **mA Output Trim** and select the output to trim.
2. Follow the instructions in the guided method.
3. Check the trim results. If any trim result is less than -20 microamps or greater than +20 microamps, contact customer service.

17.25.2 Trim mA Output using ProLink III

Trimming the mA Output establishes a common measurement range between the transmitter and the device that receives the mA Output.

Prerequisites

Ensure that the mA Output is wired to the receiving device that will be used in production.

Procedure

1. Follow the instructions in the guided method.
2. Check the trim results. If any trim result is less than -20 microamps or greater than +20 microamps, contact customer service.

17.25.3 Trim mA output using a web browser

Trimming the mA Output establishes a common measurement range between the transmitter and the device that receives the mA Output.

Prerequisites

Ensure that the mA Output is wired to the receiving device that will be used in production.

Procedure

1. Choose **Service Tools** → **Verification and Calibration** → **mA Output Trim**.
2. Follow the instructions in the guided method.
3. Check the trim results. If any trim result is less than -20 microamps or greater than +20 microamps, contact customer service.

17.26 Check the pickoff voltage

If the pickoff voltage readings are unusually low, you may have any of a variety of process or equipment problems.

To know whether your pickoff voltage is unusually low, you must collect pickoff voltage data during the problem condition and compare it to pickoff voltage data from a period of normal operation.

Drive gain and pickoff voltage are inversely proportional. As drive gain increases, pickoff voltages decrease and vice versa.

Table 17-6: Possible causes and recommended actions for low pickoff voltage

Possible cause	Recommended actions
Faulty wiring runs between the sensor and transmitter	Verify wiring between sensor and transmitter.
Process flow rate beyond the limits of the sensor	Verify that the process flow rate is not out of range of the sensor.
Sensor tubes are not vibrating	<ul style="list-style-type: none"> • Check for plugging or deposition. • Ensure that the vibrating element is free to vibrate (no mechanical binding). • Verify wiring. • Test coils at sensor. See Check the sensor coils.
Moisture in the sensor electronics	Eliminate the moisture in the sensor electronics.
The sensor is damaged, or sensor magnets may have become demagnetized	Replace the sensor.

17.27 Check power supply wiring

If the power supply wiring is damaged or improperly connected, the transmitter may not receive enough power to operate properly.

Prerequisites

- You will need the installation manual for your transmitter.

- When using DC power, a minimum of 1.5 amps of startup current is required.

Procedure

1. Use a voltmeter to test the voltage at the transmitter's power supply terminals.
 - If the voltage is within the specified range, you do not have a power supply problem.
 - If the voltage is low, ensure that the power supply is adequate at the source, the power cable is sized correctly, there is no damage to the power cable, and an appropriate fuse is installed.
 - If there is no power, continue with this procedure.
2.  **WARNING**
If the transmitter is in a hazardous area, wait five minutes after disconnecting the power. Failure to do so could result in an explosion causing death or injury.

Before inspecting the power supply wiring, disconnect the power source.

3. Ensure that the terminals, wires, and wiring compartment are clean and dry.
4. Ensure that the power supply wires are connected to the correct terminals.
5. Ensure that the power supply wires are making good contact, and are not clamped to the wire insulation.
6.  **WARNING**
If the transmitter is in a hazardous area, do not reapply power to the transmitter with the housing cover removed. Reapplying power to the transmitter while the housing cover is removed could cause an explosion.

Reapply power to the transmitter.

7. Test the voltage at the terminals.
If there is no power, contact customer service.

17.28 Check for radio frequency interference (RFI)

The transmitter's Frequency Output or Discrete Output can be affected by radio frequency interference (RFI). Possible sources of RFI include a source of radio emissions, or a large transformer, pump, or motor that can generate a strong electromagnetic field. Several methods to reduce RFI are available. Use one or more of the following suggestions, as appropriate to your installation.

Procedure

- Use shielded cable between the output and the receiving device.
 - Terminate the shielding at the receiving device. If this is impossible, terminate the shielding at the cable gland or conduit fitting.
 - Do not terminate the shielding inside the wiring compartment.
 - 360-degree termination of shielding is unnecessary.
- Eliminate the RFI source.
- Move the transmitter.

17.29 Check sensor-to-transmitter wiring

A number of power-supply and output problems may occur if the wiring between the sensor and the transmitter is improperly connected, or if the wiring becomes damaged.

Be sure to check all wiring segments:

- If you have a 4-wire transmitter, check the wiring between the transmitter and the core processor.
- If you have a 9-wire transmitter, check the wiring between the transmitter and the sensor junction box.
- If you have a remote transmitter with remote core processor, check the wiring between the transmitter and the core processor and the wiring between the core processor and the sensor junction box.

Prerequisites

You will need the installation manual for your transmitter.

Procedure

1. Before opening the wiring compartments, disconnect the power source.

 **WARNING**

If the transmitter is in a hazardous area, wait five minutes after disconnecting the power. Failure to do so could result in an explosion causing death or injury.

2. Verify that the transmitter is connected to the sensor according to the information provided in the installation manual.
3. Verify that the wires are making good contact with the terminals.
4. Check the continuity of all wires from the transmitter to the sensor.

17.30 Using sensor simulation for troubleshooting

When sensor simulation is enabled, the transmitter reports user-specified values for basic process variables. This allows you to reproduce various process conditions or to test the system.

You can use sensor simulation to help distinguish between legitimate process noise and externally caused variation. For example, consider a receiving device that reports an unexpectedly erratic density value. If sensor simulation is enabled and the observed density value does not match the simulated value, the source of the problem is likely to be somewhere between the transmitter and the receiving device.

Sensor simulation requires an enhanced core and a communication device.

Important

When sensor simulation is active, the simulated value is used in all transmitter outputs and calculations, including totals and inventories, volume flow calculations, and concentration calculations. Disable all automatic functions related to the transmitter outputs and place the loop in manual operation. Do not enable simulation mode unless your application can tolerate these effects, and be sure to disable simulation mode when you have finished testing.

17.31 Check the printing

Procedure

1. Verify that the printer is powered.
2. Verify the physical connections.
3. Verify the network settings configuration.
4. Verify that the printer is online.
See the printer manual for descriptions of status LEDs.
5. If the printer is offline:
 - a) Check the paper.
 - b) Verify the paper cover is closed correctly.

17.32 Check for two-phase flow (slug flow)

Two-phase flow can cause rapid changes in the drive gain. This can cause a variety of measurement issues.

Procedure

1. Check for two-phase flow alerts (e.g., A105).
If the transmitter is not generating two-phase flow alerts, verify that two-phase flow limits have been set. If limits are set, two-phase flow is not the source of your problem.
2. Check the process for cavitation, flashing, or leaks.
3. Monitor the density of your process fluid output under normal process conditions.
4. Check the settings of **Two-Phase Flow Low Limit**, **Two-Phase Flow High Limit**, and **Two-Phase Flow Timeout**.

Tip

You can reduce the occurrence of two-phase flow alerts by setting **Two-Phase Flow Low Limit** to a lower value, **Two-Phase Flow High Limit** to a higher value, or **Two-Phase Flow Timeout** to a higher value.

17.33 Check the sensor coils

Checking the sensor coils can identify a cause for a no sensor response alert.

Restriction

This procedure applies only to 9-wire remote-mount transmitters and remote transmitters with remote core processors. For integral mount transmitters, consult the factory.

Procedure

1. Disconnect power to the transmitter.

 **WARNING**

If the transmitter is in a hazardous area, wait five minutes after disconnecting the power. Failure to do so could result in an explosion causing death or injury.

2. Unplug the terminal blocks from the terminal board on the core processor.
3. Remove the wires from the sensor junction box.
4. Using a digital multimeter (DMM), check the pickoff coils by placing the DMM leads on the unplugged terminal blocks for each terminal pair. See [Table 17-7](#) for a list of the coils. Record the values.

Table 17-7: Coils and test terminal pairs

Coil	Sensor model	Terminal colors
Drive coil	All	Brown to red
Left pickoff coil (LPO)	All	Green to white
Right pickoff coil (RPO)	All	Blue to gray
Resistance temperature detector (RTD)	All	Yellow to violet
Lead length compensator (LLC)	All except T-Series and CMF400 (see note)	Yellow to orange
Composite RTD	CMFS025-150 and T-Series	Yellow to orange
Fixed resistor (see note)	CMFS007, CMFS010, CMFS015, CMF400, and F300	Yellow to orange

Note

The CMF400 fixed resistor applies only to certain specific CMF400 releases. Contact customer support for more information.

There should be no open circuits, that is, no infinite resistance readings. The left pickoff and right pickoff readings should be the same or very close ($\pm 5 \Omega$). If there are any unusual readings, repeat the coil resistance tests at the sensor junction box to eliminate the possibility of faulty cable. The readings for each coil pair should match at both ends.

5. Test the terminals in the sensor junction box for shorts to case.
 - a) Leave the terminal blocks disconnected.
 - b) Remove the lid of the junction box.
 - c) Testing one terminal at a time, place a DMM lead on the terminal and the other lead on the sensor case.

With the DMM set to its highest range, there should be infinite resistance on each lead. If there is any resistance at all, there is a short to case.
6. Test the resistance of junction box terminal pairs.
 - a) Test the brown terminal against all other terminals except the red one.
 - b) Test the red terminal against all other terminals except the brown one.
 - c) Test the green terminal against all other terminals except the white one.

- d) Test the white terminal against all other terminals except the green one.
- e) Test the blue terminal against all other terminals except the gray one.
- f) Test the gray terminal against all other terminals except the blue one.
- g) Test the orange terminal against all other terminals except the yellow and violet ones.
- h) Test the yellow terminal against all other terminals except the orange and violet ones.
- i) Test the violet terminal against all other terminals except the yellow and orange ones.

There should be infinite resistance for each pair. If there is any resistance at all, there is a short between terminals.

Postrequisites

To return to normal operation:

1. Plug the terminal blocks into the terminal board.
2. Replace the lid on the sensor junction box.

Important

When reassembling the meter components, be sure to grease all O-rings.

A Using the transmitter display

This section explains how to use the 5700 display. Using the display, you can move through the menus, configure the application, monitor and control the application, and perform maintenance and diagnostic tasks.

A.1 Components of the transmitter display

The transmitter display includes two status LEDs, a multi-line LCD panel, two security switches, and four optical switches.

Figure A-1: 5700 transmitter display



Status LEDs

The status LEDs indicate the current state of the transmitter (**MOD STATUS**) and the current state of the Ethernet network (**NET STATUS**).

Figure A-2: 5700 transmitter status LEDs



Table A-1: Status LED and device status

Status LED condition	Device status
Solid green	No alerts are active.
Solid yellow	One or more alerts are active with Alert Severity = Out of Specification, Maintenance Required, or Function Check.
Solid red	One or more alerts are active with Alert Severity = Failure.
Flashing yellow (1 Hz)	The <code>Function Check in Progress</code> alert is active.

Table A-2: Network status LED and Ethernet network connection status

Network status LED condition	Network status
Flashing green	No connections made with primary protocol host.
Solid green	Connection made with primary protocol host.
Flashing red	Connection from primary protocol host has timed out.
Solid red	Address Conflict Detection (ACD) algorithm has detected a duplicate IP address.

LCD panel

In normal operation, the LCD panel shows the current value of the display variables, and their measurement units.

Figure A-3: 5700 transmitter LCD panel



The LCD panel also provides access to the display menus and alert information. From the display menus, you can:

- View the current configuration and make configuration changes.
- Perform procedures such as loop testing and zero verification.
- Run batches.

The alert information allows you to see which alerts are active, acknowledge the alerts individually or as a group, and to see more detailed information for individual alerts.

A.2 Access and use the display menus

The display menus allow you to perform most configuration, administration, and maintenance tasks.

The four optical switches, \leftarrow \uparrow \downarrow \rightarrow , are used to navigate the menus, make selections, and enter data. To activate an optical switch, hold your thumb or finger over it to block the light.

Figure A-4: Optical switches



Procedure

1. Observe the action bar at the bottom of the LCD panel.
The action bar displays **Menu** \rightarrow .
2. Place your thumb or finger over the \rightarrow optical switch to activate it.
The top-level menu is displayed.
3. Navigate the menus using the four optical switches:
 - Activate \uparrow or \downarrow to scroll to the previous or next item in the menu.
 - Activate and hold \uparrow or \downarrow (approximately 1 second) to scroll rapidly through numbers or menu options, or to move to the previous screen or next screen in a multi-screen display.
 - Activate \rightarrow to drill down to a lower menu or to select an option.
 - Activate and hold \rightarrow to save and apply your action.
 - Activate \leftarrow to return to the previous menu.
 - Activate and hold \leftarrow to cancel your action.

The action bar is updated with context-sensitive information. The \rightarrow and \leftarrow symbols indicate the associated optical switch.

If the menu or the topic is too large for a single display screen, the \downarrow and \uparrow symbols at the bottom and top of the LCD panel are used to indicate that you must scroll down or up to see more information.

Figure A-5: Navigation arrows



- If you make a menu choice that leads to a possible configuration change, or to certain procedures such as zero calibration:
 - If display security is not enabled, the display prompts you to activate $\Leftarrow \Uparrow \Downarrow \Rightarrow$, in that order. This feature protects against accidental changes to configuration, but does not provide any security.

Figure A-6: Security prompts

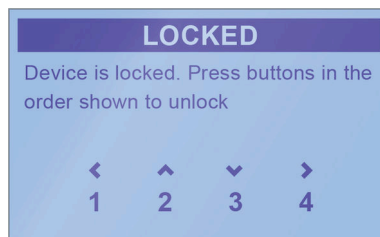

- If display security is enabled, the display prompts you to enter the display password.
- If you make a menu choice that requires entering a numeric value or character string, the display provides a screen similar to the following:

Figure A-7: Numeric values and character strings

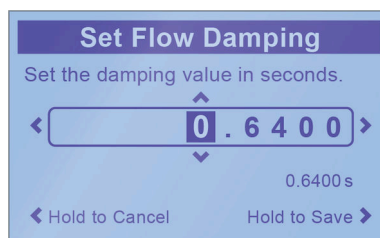

- Activate \Leftarrow or \Rightarrow to position the cursor.
- Activate \Uparrow and \Downarrow to scroll through the values that are valid for that position.
- Repeat until all characters are set.
- Activate and hold \Rightarrow to save the value.

6. To exit the display menu system, use either of the following methods:
 - Wait until the menu times out and returns to the display variables.
 - Exit each menu separately, working your way back to the top of the menu system.

B Using ProLink III with the transmitter

B.1 Basic information about ProLink III

ProLink III is a configuration and service tool available from Micro Motion. ProLink III runs on a Windows platform and provides complete access to transmitter functions and data.

Version requirements

Use the latest version of ProLink III and the device firmware to support all features. For details about ProLink III device support, refer to the `ProLink III ChangeLog.txt` file.

ProLink III requirements

To install ProLink III, you must have:

- The ProLink III installation media
- The ProLink III installation kit for your connection type:
 - Cables and connectors: Ethernet or USB port

To obtain ProLink III and the appropriate installation kit, contact customer support.

ProLink III documentation

Most of the instructions in this manual assume that you are already familiar with ProLink III or that you have a general familiarity with Windows programs. If you need more information than this manual provides, see the *Micro Motion ProLink III with ProcessViz Software User Manual*.

In most ProLink III installations, the manual is installed with the ProLink III program. Additionally, the ProLink III manual is available on the documentation CD or at www.emerson.com.

ProLink III features and functions

ProLink III offers complete transmitter configuration and operation functions. ProLink III also offers a number of additional features and functions, including:

- A Professional version with expanded features not available on the Basic version.
- The ability to save the transmitter configuration set to a file on the PC, and reload it or propagate it to other transmitters
- The ability to log specific types of data to a file on the PC
- The ability to view performance trends for various types of data on the PC
- The ability to connect to and view information for more than one device
- A guided connection wizard

These features are documented in the *Micro Motion ProLink III with ProcessViz Software User Manual*. ProLink III features are not documented in this manual.

ProLink III messages

As you use ProLink III with a Micro Motion transmitter, you will see a number of messages and notes. This manual does not document all of these messages and notes.

Important

The user is responsible for responding to messages and notes and complying with all safety messages.

B.2 Connect with ProLink III

A connection from ProLink III to your transmitter allows you to read process data, configure the transmitter, and perform maintenance and troubleshooting tasks.

B.2.1 ProLink III connection types

There are three ways to connect a ProLink III PC to the transmitter: USB connection to the Service Port, direct connection to an Ethernet port, and connection to a local area Ethernet network.

B.2.2 Configuring transmitter and PC Ethernet settings

Display	Menu → Configuration → Ethernet Settings → Network settings
ProLink III	Device Tools → Configuration → Network Settings
Web browser	Configuration → Ethernet Settings

Prerequisites

One of the following:

- An Ethernet cable directly connected between Channel A or Channel B of the transmitter and an Ethernet port on a PC.
- The transmitter and a PC connected to the same Ethernet network.

Refer to the installation manual for information about making cable connections to the transmitter.

Note

The Ethernet settings are the same for a ProLink III connection over Ethernet as they are for connecting to a web browser.

Procedure

Configure Ethernet settings as required.

- Use the display, ProLink III, or a web browser to configure the transmitter.
- Use the PC control panel to configure the PC network adapter.

Table B-1: Transmitter and PC network settings

Connection type	Transmitter network settings	PC network adapter IPv4 settings
<i>Direct connection:</i> Ethernet cable connected directly between Channel A or Channel B and the PC Ethernet adapter.	<ul style="list-style-type: none"> • Auto Obtain IP (DHCP): Disabled • IP address: any IP address in the same subnet as the PC network adapter. Recommended 192.168.0.1 • Subnet mask: 255.255.255.0 • Default Gateway: 0.0.0.0 (this indicates that no gateway will be used) 	<ul style="list-style-type: none"> • Auto Obtain IP (DHCP): Disabled • IP address: any IP address in the same subnet as the PC network adapter. Recommended 192.168.0.2 • Subnet mask: 255.255.255.0 • Default Gateway: none (leave blank)
<i>Local network connection:</i> The transmitter and PC are connected to a common network with a DHCP.	<p>All settings to be assigned by network administrator. Typical network settings shown.</p> <ul style="list-style-type: none"> • Auto Obtain IP (DHCP): Enabled • IP address: automatically assigned by DHCP • Subnet mask: 255.255.255.0 • Default Gateway: 0.0.0.0 (this indicates that no gateway will be used) 	<p>All settings to be assigned by network administrator.</p>

Note

If IP Address cannot be changed (and IP Address set from Local Display Switches appears selected on ProLink III or on a web browser page), the rotary switches on the back side of the display circuit board have been used to manually set the 4th octet of the IP address and the IP address cannot be changed using the software or display. For example, if the rotary switches are set to 005, then the IP address for the transmitter is 192.168.0.005. To remove this restriction, set the rotary switches to 000.

Note

If your PC has more than one wired network adapter, be sure to select the adapter that is connected to the transmitter.

B.2.3 Connect ProLink III to the transmitter

 **WARNING**

If the transmitter is in a hazardous area, do not remove the housing cover while the transmitter is powered up. Failure to follow these instructions can cause an explosion resulting in injury or death.

Prerequisites

The transmitter and PC must be properly configured and physically connected to each other by an Ethernet or USB cable, or they must both be connected to a local area Ethernet network.

Procedure

1. Start ProLink III.

2. Choose **Connect to Physical Device**.
3. Select a **Protocol** and related settings:
 - For Ethernet connection:
 - Select **Modbus TCP**
 - Type in the **IP Address** of the transmitter
 - Leave the remaining settings at their default values
 - For USB connection:
 - Select **Service Port**
 - Select the **PC Port** that is assigned to the PC USB Port
 - Leave the remaining settings at their default values
4. Select **Connect**.

C Using a web browser to configure the transmitter

C.1 Recommended web browsers

Browser	Version
Microsoft Internet Explorer	8 or newer
Mozilla Firefox	3.0 or newer
Google Chrome	4.1 or newer

C.2 Configuring transmitter and PC Ethernet settings

Display	Menu → Configuration → Ethernet Settings → Network settings
ProLink III	Device Tools → Configuration → Network Settings
Web browser	Configuration → Ethernet Settings

Prerequisites

One of the following:

- An Ethernet cable directly connected between Channel A or Channel B of the transmitter and an Ethernet port on a PC.
- The transmitter and a PC connected to the same Ethernet network.

Refer to the installation manual for information about making cable connections to the transmitter.

Note

The Ethernet settings are the same for a ProLink III connection over Ethernet as they are for connecting to a web browser.

Procedure

Configure Ethernet settings as required.

- Use the display, ProLink III, or a web browser to configure the transmitter.
- Use the PC control panel to configure the PC network adapter.

Table C-1: Transmitter and PC network settings

Connection type	Transmitter network settings	PC network adapter IPv4 settings
<i>Direct connection:</i> Ethernet cable connected directly between Channel A or Channel B and the PC Ethernet adapter.	<ul style="list-style-type: none"> • Auto Obtain IP (DHCP): Disabled • IP address: any IP address in the same subnet as the PC network adapter. Recommended 192.168.0.1 • Subnet mask: 255.255.255.0 • Default Gateway: 0.0.0.0 (this indicates that no gateway will be used) 	<ul style="list-style-type: none"> • Auto Obtain IP (DHCP): Disabled • IP address: any IP address in the same subnet as the PC network adapter. Recommended 192.168.0.2 • Subnet mask: 255.255.255.0 • Default Gateway: none (leave blank)
<i>Local network connection:</i> The transmitter and PC are connected to a common network with a DHCP.	<p>All settings to be assigned by network administrator. Typical network settings shown.</p> <ul style="list-style-type: none"> • Auto Obtain IP (DHCP): Enabled • IP address: automatically assigned by DHCP • Subnet mask: 255.255.255.0 • Default Gateway: 0.0.0.0 (this indicates that no gateway will be used) 	<p>All settings to be assigned by network administrator.</p>

Note

If **IP Address** cannot be changed (and **IP Address set from Local Display Switches** appears selected on ProLink III or on a web browser page), the rotary switches on the back side of the display circuit board have been used to manually set the 4th octet of the IP address and the IP address cannot be changed using the software or display. For example, if the rotary switches are set to 005, then the IP address for the transmitter is 192.168.0.005. To remove this restriction, set the rotary switches to 000.

Note

If your PC has more than one wired network adapter, be sure to select the adapter that is connected to the transmitter.

C.3 Log in with a web browser using a secure connection

You must enable the web server SSL/TLS in order to log in with a web browser. The SSL Certificate shipped with the transmitter is for IP address 192.168.0.1. After configuring the IP address, you must download a new SSL Certificate, and then import the new certificate into the web browser.

The 5700 Ethernet transmitter is shipped with SSL disabled by default. This procedure is applicable only if the SSL is enabled. If the SSL/TLS is enabled, and you changed the default IP address, order of operation is as follows:

1. Enable SSL/TLS.
2. Change the IP address.

Prerequisites

To log in to the transmitter with a web browser:

- The PC and transmitter must have been properly configured for their connection type.
- You must know the IP address of the transmitter.
- The transmitter SSL Certificate must be imported into the browser in the Trusted Root store. For instructions, see [Import the SSL Certificate into Microsoft® Windows®](#).

Procedure

1. Enter the IP address of the transmitter in the web browser address bar.
When the transmitter is found, the login page appears.
2. Enter the login credentials.

Two users are predefined. You can change the passwords, but you cannot add or delete users.

Table C-2: Login credentials

Username	Description
Admin	Complete access: <ul style="list-style-type: none"> • Can perform operator functions, such as meter verification, zero verification, starting/stopping batches, starting/stopping totals, and resetting totals • Can view and make changes to transmitter configuration
Operator	Limited access: <ul style="list-style-type: none"> • Can perform operator functions, such as meter verification, zero verification, starting/stopping batches, starting/stopping totals, and resetting totals • Can view transmitter configuration, but cannot make changes

Note

Transmitters using the default Admin password are not secure. You will see an alert if you do not change the default passwords for Admin and Operator. If you do not plan on using the web server and want to resolve the alert, disable the web server.

Upon successful login, the transmitter home page displays.

Figure C-1: Transmitter home page

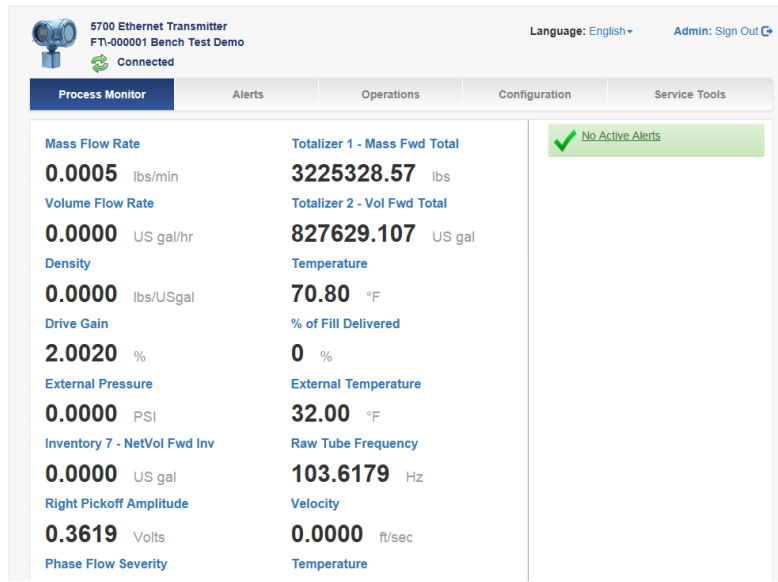

C.4 Log in with a web browser using an unsecure connection

Prerequisites

To log in to the transmitter with a web browser:

- The PC and transmitter must have been properly configured for their connection type.
- You must know the IP address of the transmitter.

Procedure

1. Enter the IP address of the transmitter in the web browser address bar. When the transmitter is found, the login page appears.
2. Enter the login credentials.

Two users are predefined. You can change the passwords, but you cannot add or delete users.

Table C-3: Login credentials

Username	Description
Admin	Complete access: <ul style="list-style-type: none"> • Can perform operator functions, such as meter verification, zero verification, starting/stopping batches, starting/stopping totals, and resetting totals • Can view and make changes to transmitter configuration

Table C-3: Login credentials (continued)

Username	Description
Operator	Limited access: <ul style="list-style-type: none"> Can perform operator functions, such as meter verification, zero verification, starting/stopping batches, starting/stopping totals, and resetting totals Can view transmitter configuration, but cannot make changes

Note

Transmitters using the default Admin password are not secure. You will see an alert if you do not change the default passwords for Admin and Operator. If you do not plan on using the web server and want to resolve the alert, disable the web server.

Upon successful login, the transmitter home page displays.

Figure C-2: Transmitter home page

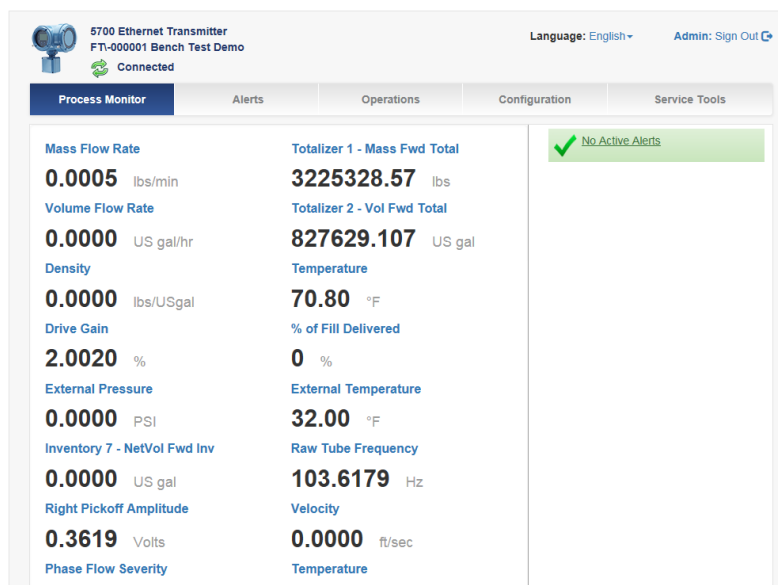

C.5 Change Ethernet login passwords

Display ⁽¹⁾	Menu → Configuration → Security → Webserver Security
ProLink III	Configuration → Communications → Webserver Settings
Web browser	Configuration → Security

(1) Applicable only when the web server is enabled.

The Ethernet login passwords prevent unauthorized access to the transmitter. Immediately change the Admin and Operator passwords from the default password, and keep them confidential.

Procedure

Enter new passwords for **Admin Password** and **Operator Password**.

Passwords must have:

- At least 8, but no more than 14 characters.
- At least one uppercase letter
- At least one lowercase letter
- At least one number
- At least one special character (! " # \$ % ' () * + , - . & / : ; = > < ?

C.6 Import the SSL Certificate into Microsoft® Windows®

This procedure imports the certificate for your computer and will be applied to Google Chrome™ and Microsoft Internet Explorer used on that computer. See [Recommended web browsers](#).

Procedure

1. Open the **Start** menu and type `mmc` in the search box.
2. Go to **File** → **Add/Remove Snap-in...**
3. Select **Certificates** from the left pane.
4. Select **Add** in the center of the window to add **Certificates** to the **Selected snap-ins** pane.
5. Select the radio button for **Computer account**.
6. Select **Next** and then select the radio button for **Local Computer**.
7. Select **Finish** and then **OK**.
8. From **Console Root** to **Certificates** → **Trusted Root Certification Authorities**, expand **Certificates**.

Important

You must import the certificate to the Trusted Root store.

9. Right-click **Certificates** and select **All Tasks** → **Import...**
The Certificate Import Wizard displays.
10. Select **Next** and verify that the certificate is being placed in the Trusted Root Certification Authorities store.
11. Select **Next** and then **Finish**.

A message displays telling you that the import was successful.

The Certificate displays at the top of the main pane, listed by IP address.

Issued To	Issued By	Expiration Date	Intended Purposes	Friendly Name	Status	Certificate Te...
192.168.0.2	192.168.0.2	10/14/2068	<All>	<None>		

C.7 Private key file

Under most circumstances, the private key does not need to be exported, except in a rare case where you can use it to debug a failing TLS connection. In that case, once it is exported into the open world, it is safer to re-generate a new key after the issue is resolved. You can debug almost all TLS connection problems without needing to see the private key.

To generate a new certificate, change the IP address. If you want the same IP address, change it back. On each acceptance of a new IP address, a new certificate is generated.

C.8 Import from a Certificate Authority

You have the option to import a certificate and a private key pair obtained from a Certificate Authority (CA).

The transmitter accepts certificates and keys that match the following requirements:

- ECDSA (ECC) private keys on one of NIST P-256 curve
- Certificates including the following signature types (on the above curve):
 - + ecdsa-with-SHA1
 - + ecdsa-with-SHA256
 - + ecdsa-with-SHA384
 - + ecdsa-with-SHA512

Note

Keys and certificates using RSA will not work with the transmitter.

Prerequisites

- The files must be titled, `mmi-ecc-cert.cer` and `mmi-ecc-key.cer`.
- The certificate and private key must match the algorithms and key sizes configured for the transmitter.

Procedure

1. Save the `mmi-ecc-cert.cer` and `mmi-ecc-key.cer` files to a folder on a USB memory stick.
2. Insert the memory stick into the transmitter's service port.
The USB options menu displays.
3. Follow the prompts to import the files.

D Concentration measurement matrices, derived variables, and process variables

D.1 Standard matrices for the concentration measurement application

The standard concentration matrices available from Micro Motion are applicable for a variety of process fluids. These matrices are included in the ProLink III installation.

Tip

If the standard matrices are not appropriate for your application, you can build a custom matrix or purchase a custom matrix from Micro Motion.

Matrix name	Description	Density unit	Temperature unit	Derived variable
Deg Balling	Matrix represents percent extract, by mass, in solution, based on °Balling. For example, if a wort is 10 °Balling and the extract in solution is 100% sucrose, the extract is 10% of the total mass.	g/cm ³	°F	Mass Concentration (Density)
Deg Brix	Matrix represents a hydrometer scale for sucrose solutions that indicates the percent by mass of sucrose in solution at a given temperature. For example, 40 kg of sucrose mixed with 60 kg of water results in a 40 °Brix solution.	g/cm ³	°C	Mass Concentration (Density)
Deg Plato	Matrix represents percent extract, by mass, in solution, based on °Plato. For example, if a wort is 10 °Plato and the extract in solution is 100% sucrose, the extract is 10% of the total mass.	g/cm ³	°F	Mass Concentration (Density)
HFCS 42	Matrix represents a hydrometer scale for HFCS 42 (high-fructose corn syrup) solutions that indicates the percent by mass of HFCS in solution.	g/cm ³	°C	Mass Concentration (Density)
HFCS 55	Matrix represents a hydrometer scale for HFCS 55 (high-fructose corn syrup) solutions that indicates the percent by mass of HFCS in solution.	g/cm ³	°C	Mass Concentration (Density)
HFCS 90	Matrix represents a hydrometer scale for HFCS 90 (high-fructose corn syrup) solutions that indicates the percent by mass of HFCS in solution.	g/cm ³	°C	Mass Concentration (Density)

D.2 Derived variables and calculated process variables

The concentration measurement application calculates a different set of process variables from each derived variable. The process variables are then available for viewing or reporting.

Derived variable	Description	Calculated process variables					
		Density at reference temp	Standard volume flow rate	Specific gravity	Concentration	Net mass flow rate	Net volume flow rate
Density at Reference	Mass/unit volume, corrected to a given reference temperature	✓	✓				
Specific Gravity	The ratio of the density of a process fluid at a given temperature to the density of water at a given temperature The two given temperature conditions do not need to be the same. Note The two given temperature conditions do not need to be the same.	✓	✓	✓			
Mass Concentration (Density)	The percent mass of solute or of material in suspension in the total solution, derived from reference density	✓	✓		✓	✓	
Mass Concentration (Specific Gravity)	The percent mass of solute or of material in suspension in the total solution, derived from specific gravity	✓	✓	✓	✓	✓	
Volume Concentration (Density)	The percent volume of solute or of material in suspension in the total solution, derived from reference density	✓	✓		✓		✓
Volume Concentration (Specific Gravity)	The percent volume of solute or of material in suspension in the total solution, derived from specific gravity	✓	✓	✓	✓		✓

Derived variable	Description	Calculated process variables					
		Density at reference temp	Standard volume flow rate	Specific gravity	Concentration	Net mass flow rate	Net volume flow rate
Concentration (Density)	The mass, volume, weight, or number of moles of solute or of material in suspension in proportion to the total solution, derived from reference density	✓	✓		✓		
Concentration (Specific Gravity)	The mass, volume, weight, or number of moles of solute or of material in suspension in proportion to the total solution, derived from specific gravity	✓	✓	✓	✓		

E Environmental compliance

E.1 RoHS and WEEE

In compliance with the RoHS directive (Restriction of Hazardous Substances) and the WEEE directive (Waste Electrical and Electronic Equipment), the battery in the 5700 transmitter cannot be serviced or replaced by users. If the battery requires replacement, contact customer service for replacement and disposal.



F Example tickets

This appendix provides examples of different types of tickets.

F.1 Print examples

Original tickets

Figure F-1: Sample test page

```
Header1
Header2
Header3
Header4
FT-1000
28/AUG/2017 07:45:55
=====
-- Ticket data will be --
-- printed in this area --
=====
Footer
```

Figure F-2: Batch ticket with Weights and Measures not licensed

```
Header1
Header2
FT-0000
28/AUG/2017 07:33:26
Preset 1
grams
Actual : 1098.68
Target : 1000.00
Footer
```

F.1.1 Batch (NTEP) tickets

Original tickets

Figure F-3: Data secured

```
Header1
Header2
Header3
Header4
FT-1000
28/AUG/2017 07:45:55
Total:1109.17 grams
Batch Count : 2
Footer
```

Figure F-4: Data unsecured

```
Header1
Header2
Header3
Header4
FT-1000
28/AUG/2017 07:51:55
Total : 1035.06 grams
Batch Count : 3
Security Breach
Not Legal For Trade
Footer
```



MMI-20029769
Rev. AG
2021

For more information: www.emerson.com

©2021 Micro Motion, Inc. All rights reserved.

The Emerson logo is a trademark and service mark of Emerson Electric Co. Micro Motion, ELITE, ProLink, MVD and MVD Direct Connect marks are marks of one of the Emerson Automation Solutions family of companies. All other marks are property of their respective owners.

MICRO MOTION™

