

Rosemount™ 2130 Level Switch

Vibrating Fork



Safety messages

NOTICE

Read this manual before working with the product. For personal and system safety, and for optimum product performance, ensure you thoroughly understand the contents before installing, using, or maintaining this product.

For technical assistance, contacts are listed below:

Customer Central

Technical support, quoting, and order-related questions.

- United States - 1-800-999-9307 (7:00 am to 7:00 pm CST)
- Asia Pacific- 65 777 8211

North American Response Center

Equipment service needs.

- 1-800-654-7768 (24 hours a day — includes Canada)
- Outside of these areas, contact your local Emerson representative.

⚠ WARNING

Failure to follow safe installation and servicing guidelines could result in death or serious injury.

Ensure the level switch is installed by qualified personnel and in accordance with applicable code of practice.

Use the level switch only as specified in this manual. Failure to do so may impair the protection provided by the level switch.

The weight of a level switch with a heavy flange and extended fork length may exceed 37 lb. (18 kg). A risk assessment is required before carrying, lifting, and installing the level switch.

⚠ WARNING

Explosions could result in death or serious injury.

Verify the operating atmosphere of the level switch is consistent with the appropriate hazardous locations certifications.

Before connecting a handheld communicator in an explosive atmosphere, ensure the instruments are installed in accordance with intrinsically safe or non-incendive field wiring practices.

In explosion-proof/flameproof and non-incendive installations, do not remove the housing cover when power is applied to the level switch.

The housing cover must be fully engaged to meet flameproof/explosion-proof requirements.

⚠ WARNING

Electrical shock could cause death or serious injury.

Avoid contact with the leads and terminals. High voltage that may be present on leads can cause electrical shock.

Ensure the power to the level switch is off, and the lines to any other external power source are disconnected or not powered while wiring the level switch.

Ensure the wiring is suitable for the electrical current and the insulation is suitable for the voltage, temperature, and environment.

⚠ WARNING

Process leaks could result in death or serious injury.

Ensure the level switch is handled carefully. If the process seal is damaged, gas might escape from the vessel (tank) or pipe.

⚠ WARNING

Any substitution of non-recognized parts may jeopardize safety. Repair (e.g. substitution of components) may also jeopardize safety and is not allowed under any circumstances.

Unauthorized changes to the product are strictly prohibited as they may unintentionally and unpredictably alter performance and jeopardize safety. Unauthorized changes that interfere with the integrity of the welds or flanges, such as making additional perforations, compromise product integrity and safety. Equipment ratings and certifications are no longer valid on any products that have been damaged or modified without the prior written permission of Emerson. Any continued use of product that has been damaged or modified without the written authorization is at the customer's sole risk and expense.

⚠ WARNING

Physical access

Unauthorized personnel may potentially cause significant damage to and/or misconfiguration of end users' equipment. This could be intentional or unintentional and needs to be protected against.

Physical security is an important part of any security program and fundamental to protecting your system. Restrict physical access by unauthorized personnel to protect end users' assets. This is true for all systems used within the facility.

⚠ CAUTION

The products described in this document are NOT designed for nuclear-qualified applications.

Using non-nuclear qualified products in applications that require nuclear-qualified hardware or products may cause inaccurate readings.

For information on Rosemount nuclear-qualified products, contact your local Emerson Sales Representative.

⚠ CAUTION

Hot surfaces

The flange and process seal may be hot at high process temperatures. Allow to cool before servicing.



Contents

Chapter 1	Introduction.....	7
	1.1 Using this manual.....	7
	1.2 Product certifications.....	7
	1.3 Product recycling/disposal.....	7
Chapter 2	Level switch overview.....	9
	2.1 Measurement principles.....	9
	2.2 Process characteristics.....	9
	2.3 Vessel characteristics.....	9
	2.4 Application examples.....	10
	2.5 Components of the level switch.....	12
Chapter 3	Mechanical installation.....	15
	3.1 Safety messages.....	15
	3.2 Installation considerations.....	16
	3.3 Installation procedures.....	25
Chapter 4	Electrical installation.....	31
	4.1 Safety messages.....	31
	4.2 Prepare the electrical connections.....	32
	4.3 Connect wiring and power up.....	47
Chapter 5	Operation.....	51
	5.1 Output mode and time delay.....	51
	5.2 LED indication status.....	52
	5.3 Set the operating mode.....	53
Chapter 6	Service and troubleshooting.....	55
	6.1 Safety messages.....	55
	6.2 Magnetic test point.....	56
	6.3 Visual inspection.....	57
	6.4 Maintenance.....	58
	6.5 Troubleshooting.....	58
	6.6 Spare parts.....	60
	6.7 Replacement and calibration of cassettes.....	60
	6.8 Opening the lid (cover).....	62
	6.9 Service support.....	63
Appendix A	Specifications and reference data.....	65
	A.1 General.....	65
	A.2 Physical specifications.....	65
	A.3 Performance specifications.....	66

A.4 Electrical specifications..... 67

A.5 Functional specifications..... 68

A.6 Environmental specifications..... 68

A.7 Dimensional drawings..... 70

1 Introduction

1.1 Using this manual

The sections in this manual provide detailed information on installing, operating, and maintaining the Rosemount 2130 Level Switch - Vibrating Fork.

The sections are organized as follows:

[Level switch overview](#) provides a description of the level switch and its basic principles.

[Mechanical installation](#) contains mechanical installation instructions.

[Electrical installation](#) contains electrical installation instructions.

[Operation](#) contains how to adjust the operation and what the LED indications mean.

[Service and troubleshooting](#) provides troubleshooting techniques for the most common operating problems.

[Specifications and reference data](#) supplies reference and specification data.

1.2 Product certifications

See the Rosemount 2130 [Product Certifications](#) document for detailed information on the existing approvals and certifications.

1.3 Product recycling/disposal

Recycling of equipment and packaging should be taken into consideration and disposed of in accordance with local and national legislation or regulations.

Related information

[Service support](#)

2 Level switch overview

2.1 Measurement principles

Using the principle of a tuning fork, a piezo-electric crystal oscillates the forks at their natural frequency. Changes to the oscillation frequency are continuously monitored by electronics as it varies depending on the liquid medium in which the forks are immersed. The denser the liquid, the lower the oscillation frequency.

When used as a low-level point alarm, the liquid medium in the vessel (tank) or pipe drains down past the fork, causing a change of oscillation frequency that is detected by the electronics and switches the output state i.e. wet-to-dry.

When the level switch is used as a high-level point alarm, the liquid rises in the vessel (tank) or pipe making contact with the fork and causing the output state to switch i.e. dry-to-wet.

2.2 Process characteristics

Emerson's vibrating fork technology is virtually unaffected by turbulence, foam, solids content, coating products, and liquid properties. The natural frequency (1400 Hz) of the fork avoids interference from plant vibration that may cause false switching to a wet state. This allows for minimum intrusion into the tank or pipe using a short fork.

2.3 Vessel characteristics

The level switch should be mounted using its process connection, and in a horizontal or vertical orientation so that the liquid medium can flow freely in the gap between the forks.

A vessel (tank) or pipe can be almost any shape or type, but check that the process conditions are within the operating limits of the level switch.

Avoid installing near agitators and inlet pipes where the forks are likely to be splashed and cause a false switch to a wet state. False switching events can be minimized by an adjustable time delay on the electronics cassette and allows time for the fork to dry.

Never force the level switch into a vessel (tank) or pipe space. Any contact with the opposite wall, or in-tank objects, could damage the forks and other wetted-process parts.

Extended length versions require supports at regular spaced intervals.

Related information

[Required supports for extended fork](#)

2.4 Application examples

Overfill prevention

Spillage caused by overfilling can be hazardous to people and the environment, resulting in lost product and potentially high clean-up costs. The Rosemount 2130 is an overfill prevention product from Emerson that can be used as one of multiple layers of protection. It has been third party assessed and certified to IEC 61508.



High and low level point alarm

Maximum and minimum level detection in tanks containing different types of liquids are ideal applications. It is common practice to have an independent high level alarm switch as a backup to an installed level device in case of primary failure.

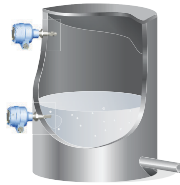

Pump control or limit detection

Batch processing tanks often contain stirrers and agitators to ensure mixing and product 'fluidity'. The Rosemount 2130 has a user-selectable time delay, from 0.3 to 30 seconds, that virtually eliminates the risk of false switching from splashing.

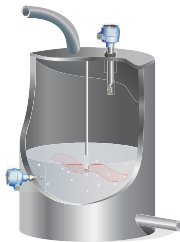

Pump protection or empty pipe detection

With the fork projecting only 2 in. (50 mm) (dependent on connection type), the Rosemount 2130 can be installed in small diameter pipes. Short forks mean minimum intrusion on the wet side and allow for simple, low cost installation at any angle into pipes or tanks. By selecting the option of direct load switching or relay electronics, the Rosemount 2130 is ideal for reliable pump control and can be used to protect against pumps running dry.



High-temperature applications

The 2130***E version is designed for high temperatures and is suitable for continuous operation within the process temperature range of -94 to 500 °F (-70 to 260 °C).

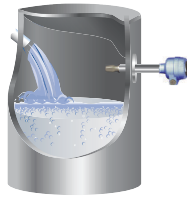

Wireless applications

The advent of wireless communications allows process plant managers to save up to 90% on installation cost compared with wired technologies. More data can be collected at central locations than has ever been possible before. The Rosemount 2130 can be used with a Rosemount 702 Wireless Discrete Transmitter to enable these benefits for your applications.



Hygienic applications

With the highly polished forks option providing a surface finish (Ra) better than 0.4 μm , the Rosemount 2130 meets the most stringent hygienic requirements used in food and beverage, and pharmaceutical applications. The Rosemount 2130 is robust enough to easily withstand CIP (Clean-In-Place) and SIP (Steam-In-Place) cleaning routines.

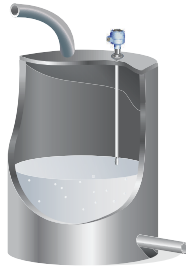

2.5 Components of the level switch

Figure 2-1 shows the components of a Rosemount 2130.

Figure 2-1: Rosemount 2130 Features

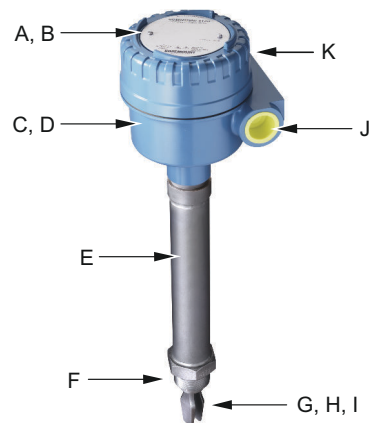

- A. Direct Load, DPCO Relay, Fault + Alarm (2 x SPCO) Relays, PLC/PNP, NAMUR, or 8/16 mA electronics
- B. Mode switch, adjustable time delay, and 'heartbeat' LED
- C. Housings in aluminum or 316 stainless steel
- D. Magnetic test point
- E. Thermal tube in 316/316L stainless steel (2130***E version only)
- F. Threaded, flanged, or Tri Clamp process connections
- G. 'Fast drip' fork design
- H. Wetted material in 316/316L stainless steel, Alloy C and Alloy C-276, or ECTFE-coated 316/316L stainless steel
- I. Short fork length or extensions up to 157.5-in. (4 m)
- J. Two cable/ conduit entries
- K. External ground screw

2.5.1 Short fork technology

Using short-fork technology, the device can be used in almost all liquid applications. Extensive research has maximized the operational effectiveness of the fork design, making it suitable for most liquid mediums including coating liquids, aerated liquids, and slurries.

2.5.2 Fork design

The “fast drip” design allows the liquid to be quickly drawn away from the fork tip, making the Rosemount 2130 quicker and more responsive in high density or viscous liquid applications.

Figure 2-2: “Fast drip” forks



2.5.3 Instrument health monitor and continuous self-check

The Rosemount 2130 continuously performs instrument health diagnostics to self-check the condition of the fork and sensor. These diagnostics can detect damage to the forks including corrosion, internal or external damage to the forks, and breakages to the internal wiring.

Detected damage will trigger the 'heartbeat' LED to pulse intermittently, followed by safe handling of the electrical load.

2.5.4 Heartbeat LED

Each electronics cassette of the level switch has a 'heartbeat' LED indicating its operation status. The LED flashes when the level switch output is 'off' and is constantly lit when 'on'.

The LED gives a constant indication that the level switch is functioning correctly (different flash rates are used to indicate a product malfunction) and gives a local indication of the process state.

2.5.5 Mode switch and adjustable output delay

A mode switch on the electronics cassette allows the level switch output to be 'on' or 'off' when the forks are wet or dry. Typically is set to 'dry on' (for a low-level point alarm) or 'wet on' (for a high-level point alarm). There is also a user-selectable time delay (0.3, 1, 3, 10, or 30 seconds) on the electronics cassette to virtually eliminate the risk of false switching in turbulent or splashing applications.

2.5.6 Magnetic test point

A magnetic test point is located on the side of the housing, allowing a functional test of the Rosemount 2130 and a system connected to it. Holding a magnet to the test point causes the output to change state.

2.5.7 Electrical connections

The terminal blocks extend above the housing and give easy terminal access. Electrical protections make electrical hook-up safe and easy.

3 Mechanical installation

3.1 Safety messages

Instructions and procedures in this section may require special precautions to ensure the safety of the personnel performing the operations. Information that potentially raises safety issues is indicated by a warning symbol () . Refer to the following safety messages before performing an operation preceded by this symbol.

WARNING

Failure to follow safe installation and servicing guidelines could result in death or serious injury.

Ensure the level switch is installed by qualified personnel and in accordance with applicable code of practice.

Use the level switch only as specified in this manual. Failure to do so may impair the protection provided by the level switch.

The weight of a level switch with a heavy flange and extended fork length may exceed 37 lb. (18 kg). A risk assessment is required before carrying, lifting, and installing the level switch.

Repair, e.g. substitution of components, etc. may jeopardize safety and is under no circumstances allowed.

WARNING

Explosions could result in death or serious injury.

Verify the operating atmosphere of the level switch is consistent with the appropriate hazardous locations certifications.

Before connecting a handheld communicator in an explosive atmosphere, ensure the instruments are installed in accordance with intrinsically safe or non-incendive field wiring practices.

In explosion-proof/flameproof and non-incendive installations, do not remove the housing cover when power is applied to the level switch.

The housing cover must be fully engaged to meet flameproof/explosion-proof requirements.

⚠ WARNING

Electrical shock could cause death or serious injury.

Avoid contact with the leads and terminals. High voltage that may be present on leads can cause electrical shock.

Ensure the power to the level switch is off, and the lines to any other external power source are disconnected or not powered while wiring the level switch.

Ensure the wiring is suitable for the electrical current and the insulation is suitable for the voltage, temperature, and environment.

⚠ WARNING

Process leaks could result in death or serious injury.

Ensure the level switch is handled carefully. If the process seal is damaged, gas might escape from the vessel (tank) or pipe.

⚠ WARNING

Physical access

Unauthorized personnel may potentially cause significant damage to and/or misconfiguration of end users' equipment. This could be intentional or unintentional and needs to be protected against.

Physical security is an important part of any security program and fundamental to protecting your system. Restrict physical access by unauthorized personnel to protect end users' assets. This is true for all systems used within the facility.

⚠ CAUTION

Hot surfaces

The flange and process seal may be hot at high process temperatures. Allow to cool before servicing.



3.2 Installation considerations

Before installing the level switch, review the safety, environmental, application, and pre-installation sections.

3.2.1 Environmental considerations

The Rosemount 2130 is weatherproof and protected against the ingress of dust, but must be protected from flooding. Avoid installing the level switch near heat sources.

Figure 3-1: Environmental Considerations

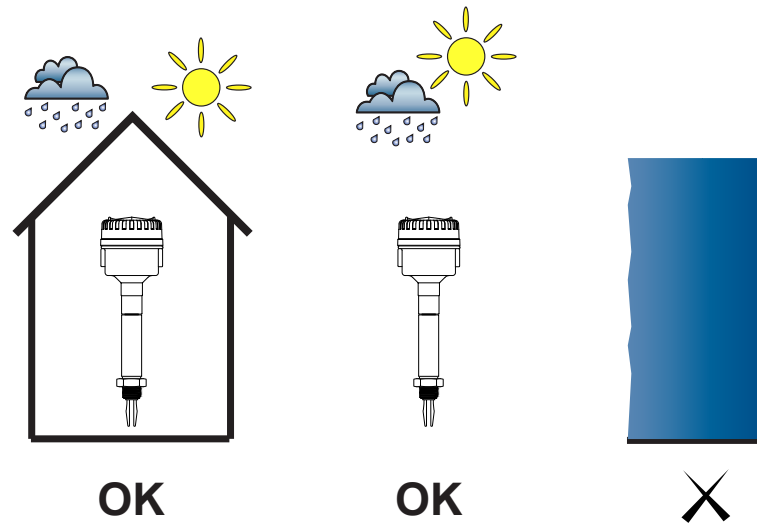

3.2.2 Application considerations

The Rosemount 2130 is a wired point-level device for use on open or closed vessels (tanks) and in pipework containing liquid mediums.

For most liquids, including coating, aerated liquids and slurries, the function is virtually unaffected by flow, turbulence, bubbles, foam, vibration, solid particles, build-up, or properties of the liquid medium.

Avoid process medium build-up on the forks

Avoid situations where a drying and coating process medium may create an excessive build-up or implement preventative maintenance programs to ensure the build-up is not enough to impair performance (see [Figure 3-2](#)).

Always ensure:

- There is sufficient distance between build-up on the tank wall and the fork.
- There is no risk of 'bridging' the level switch forks.

Examples of products that can create 'bridging' of forks and impair performance are dense paper slurries and bitumen.

Figure 3-2: Avoid Product Build-up

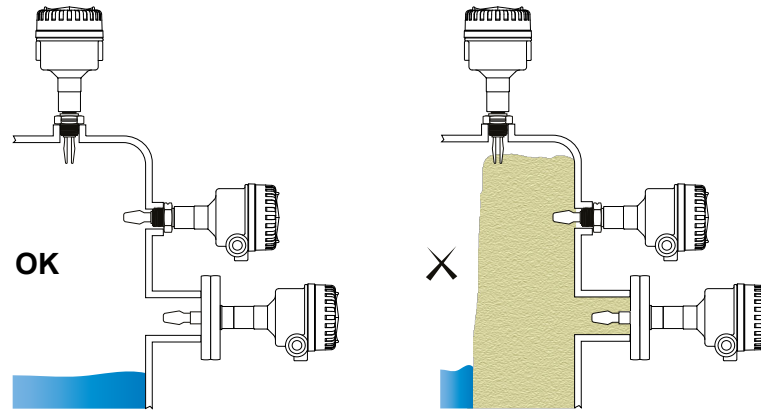

Operating temperature and pressure ranges

Ensure the process is operating within the instrument operating temperature and pressure ranges.

Liquid density requirements

Minimum standard density is 37.5 lb/ft³ (600 kg/m³).

Minimum density is 31.2 lb/ft³ (500 kg/m³ when ordered with the Low Density Range option).

Liquid viscosity range

Up to 10000 cP (centiPoise) when operating in the Normal mode.

Up to Up to 1000 cP (centiPoise) when operating in Self-check mode.

Solids content in the liquid medium

As a guideline, the maximum solid particle diameter in the liquid process medium is 0.2 in. (5 mm). Extra consideration is needed when solid particles are bigger than 0.2 in. (5 mm) and advice should be sought from Emerson.

Foams

In almost all cases, the Rosemount 2130 is insensitive to foams (i.e. does not see the foam).

However in rare occasions, some very dense foams may be seen as liquid; known examples of this are found in ice-cream and orange juice manufacturing.

Switching point

The switching point varies with different liquid densities. The switching point (SP) and hysteresis (HY) for water are shown in [Figure 3-3](#).

Figure 3-3: Switching Point in Inches (Millimeters)

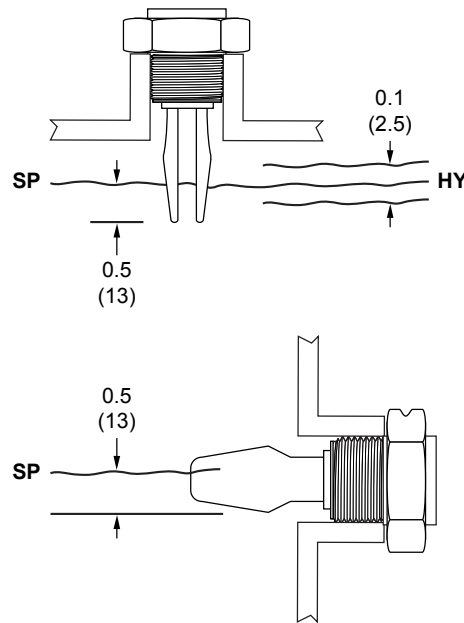

Note

When mounted vertically, a low density medium has a switching point closer to the process connection. A high density medium has a switching point closer to fork tip.

3.2.3 Pre-installation considerations

Measurement accuracy is dependent upon the proper installation of the device. Keep in mind the need for easy access, personnel safety, practical field calibration, and a suitable environment for the device.

Device identification

To identify a version of the level switch, see the labels on the housing and on the electronics cassette inside the housing.

How to handle a level switch

Handle the level switch with great care.

The weight of the level switch with a heavy flange and extended fork length may exceed 37 lb. (18 kg). A risk assessment is required to be done before carrying, lifting, and installing the level switch.

Use both hands to carry the extended length and high temperature versions, and do not hold a level switch by the forks (see [Figure 3-4](#)).

Figure 3-4: Handling

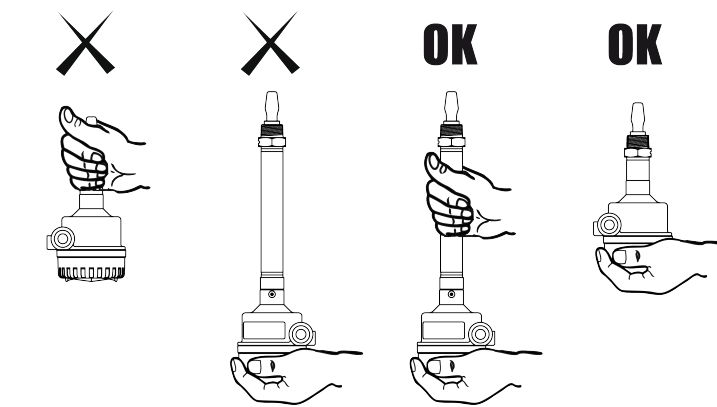

Make no alterations to the level switch

Never make any alterations to the mechanical or electrical features of the level switch.

Figure 3-5: Make No Alterations

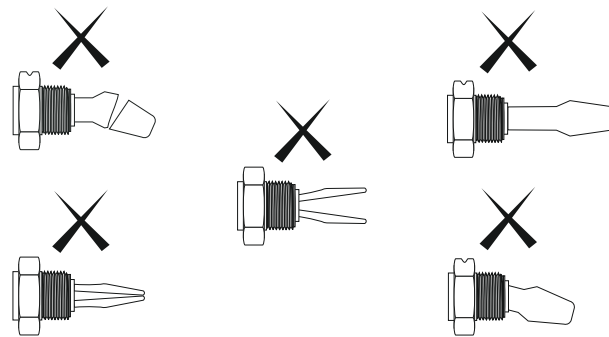

Allow adequate space outside tank or pipe

Mount the level switch so that it is removable and allow easy access to the wiring terminals when the top cover is removed. Ensure there is also enough room for fitting cable glands and cables.

A clearance of 1.2 in. (30 mm) is required for the top cover to be removed.

Note

The electronics housing cannot be rotated to assist with the cabling.

Covers installation

Ensure a proper seal by installing the electronics housing cover so that metal contacts metal. Always use Emerson's O-rings.

Mounting orientation

Mount the Rosemount 2130 at any angle that allows the level of the process medium to rise, fall, or flow through the fork gap.

Related information

[Correct fork alignment](#)

Insulation

Figure 3-6: Insulation

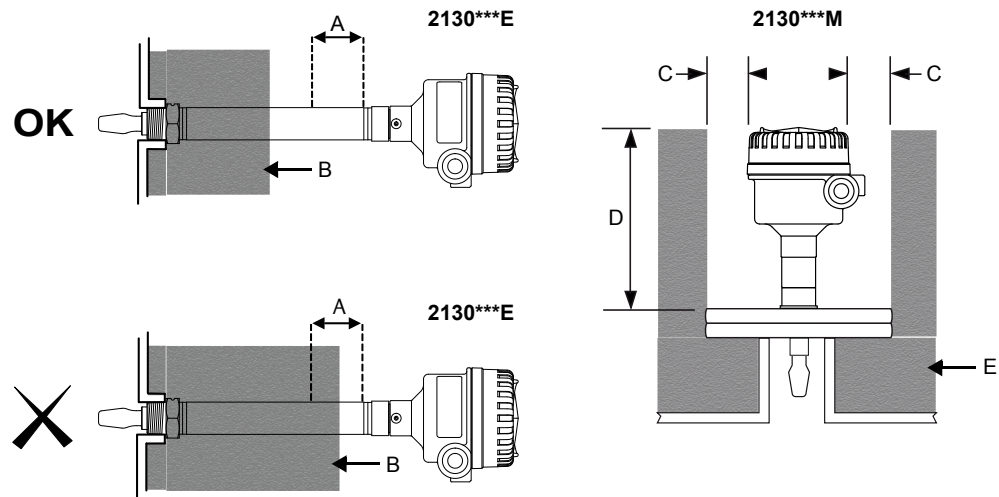

- A. 2.1 in. (55 mm)
- B. ROCKWOOL® surrounds the Rosemount 2130
- C. 3.9 in. (100 mm) clearance all around
- D. 5.9 in. (150 mm)
- E. ROCKWOOL

Pipe installation requirements

- The inside pipe diameter (D) must be 1.4 in. (35 mm) or larger.
- Ensure the fork tines intrude at least 0.9 in. (22 mm) into the pipe.
- Keep at least 0.3 in. (7 mm) of clearance between the fork tines and the pipe wall.

Figure 3-7: Pipe Installation

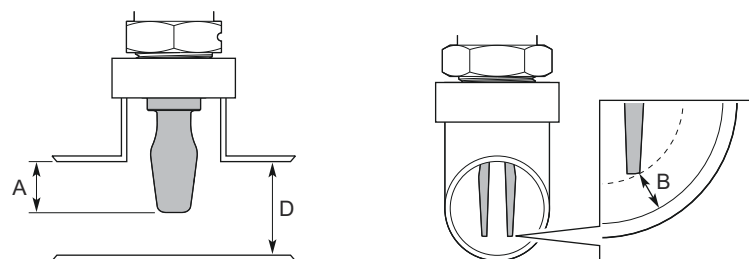

- A. Minimum intrusion 0.9 in. (22 mm)
- B. Minimum clearance 0.3 in. (7 mm)

Other recommendations

- Always install in the normally “on” state.
 - High-level alarm: recommended Mode setting is **Dry = on**.
 - Low-level alarm: recommended Mode setting is **Wet = on**.
- Avoid:
 - Installing near to liquid entering the tank at the filling-point.
 - Heavy splashing on the forks.

Increasing the sensor output delay reduces accidental detection caused by splashing.

- Always ensure:
 - The overall system is tested during commissioning by using the local magnetic test point.
 - The installation does not create tank crevices around the forks where a liquid medium may collect. This event can happen with high-viscosity and high-density liquids.
 - The forks do not come into contact with the vessel (tank) or pipe wall, internal fittings, or any other obstructions.
- Extra consideration is needed if the plant vibration is close to the 1400 Hz operating frequency of the fork.

Required supports for extended fork

Supporting the extended fork avoids long fork length vibration.

Figure 3-8: Vertical Installation (Standard)

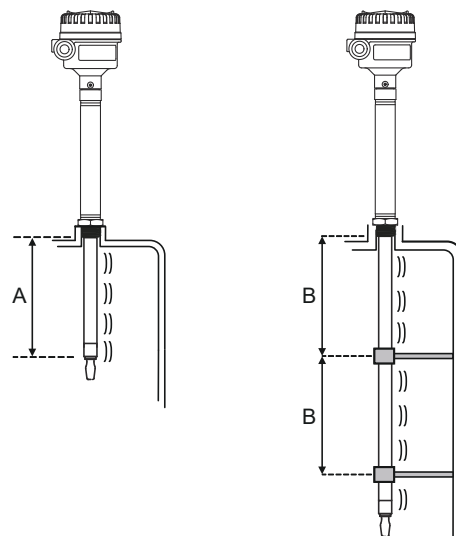

A. Maximum 3.28 ft. (1.0 m)

B. 3.28 ft. (1.0 m)

Figure 3-9: Vertical Installation (Marine GL Approved)

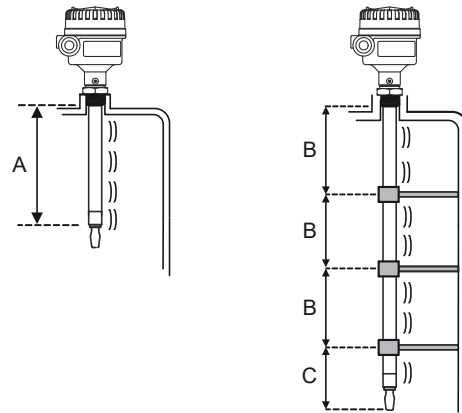

- A. Maximum 1.3 ft. (0.4 m)
- B. 2.3 ft. (0.7 m)
- C. 0.65 ft. (0.2 m)

Figure 3-10: Horizontal Installation (Standard)

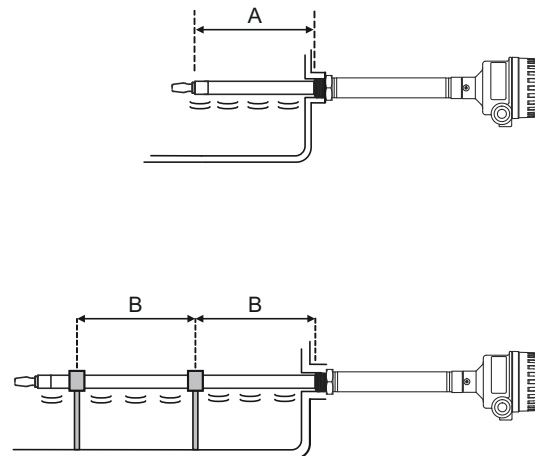

- A. Maximum 3.28 ft. (1.0 m)
- B. 3.28 ft. (1.0 m)

Figure 3-11: Horizontal Installation (Marine GL Approved)

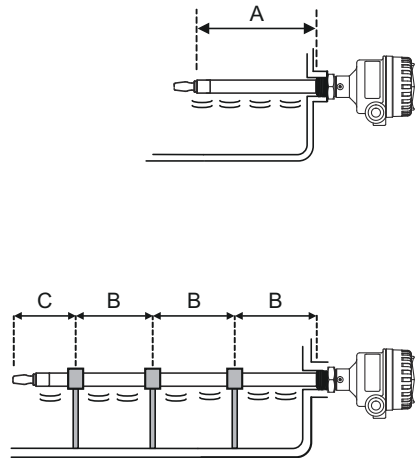

- A. Maximum 1.3 ft. (0.4 m)
- B. 2.3 ft. (0.7 m)
- C. 0.65 ft. (0.2 m)

3.3 Installation procedures

3.3.1 Process connection seals

Figure 3-12: Process Connection Seals

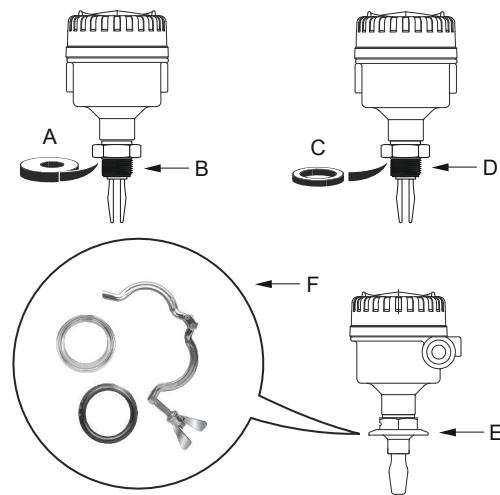

- A. PTFE tape
- B. NPT or BSPT (R) thread
- C. Gasket
- D. BSPP (G) thread
- E. Tri Clamp
- F. The Tri Clamp seal is supplied in an accessory kit

3.3.2 Correct fork alignment

Fork alignment in a vessel (tank) installation

The fork is correctly aligned by positioning the groove or notch as indicated (Figure 3-13).

Figure 3-13: Correct Fork Alignment for Vessel (Tank) Installation

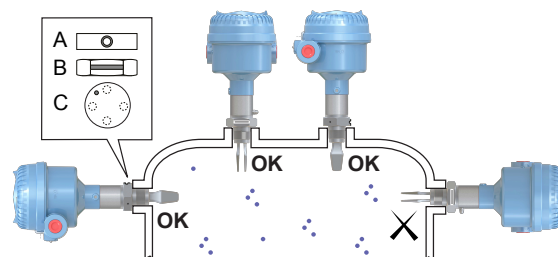

- A. Tri Clamp process connections have a circular notch
- B. Threaded process connections have a groove
- C. Flanged process connections have a circular notch

Fork alignment in a pipe installation

The fork is correctly aligned by positioning the groove or notch as indicated (Figure 3-14).

Figure 3-14: Correct Fork Alignment for Pipe Installation

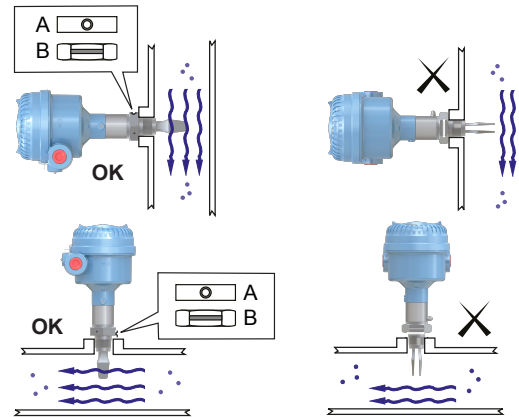

- A. Tri Clamp process connections have a circular notch
- B. Threaded process connections have a groove

3.3.3

Mounting the threaded version

Threaded vessel (tank) or pipework connection

Procedure

1. Seal and protect the threads. Use anti-seize paste or PTFE tape according to site procedures.

A gasket may be used as a sealant for BSPP (G) threaded connections.

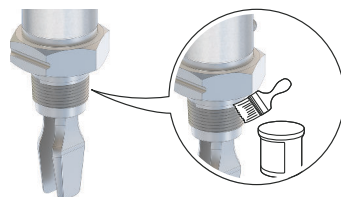

2. Screw the level switch into the process connection.

Note

Tighten using the hexagon nut only.

Figure 3-15: Vertical Installation

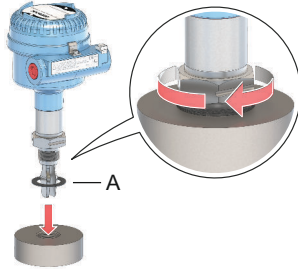

A. Gasket for BSPP (G) threaded connection

Figure 3-16: Horizontal Installation

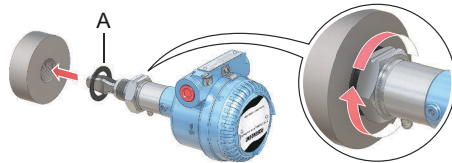

A. Gasket for BSPP (G) threaded connection

Threaded flange connection

Procedure

1. Place the customer-supplied flange and gasket on the vessel (tank) nozzle.

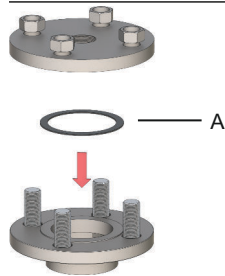

A. Gasket (customer supplied)

2. Tighten the bolts and nuts with sufficient torque for the flange and gasket.

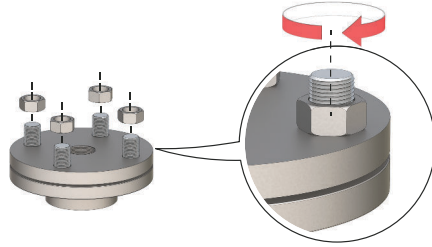

3. Seal and protect the threads. Use anti-seize paste or PTFE tape according to site procedures.

A gasket may be used as a sealant for BSPP (G) threaded connections.

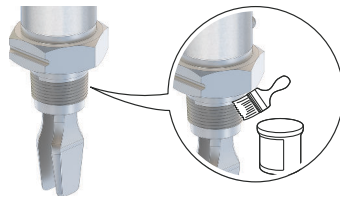

4. Screw the level switch into the flange thread.

Note

Tighten using the hexagon nut only.

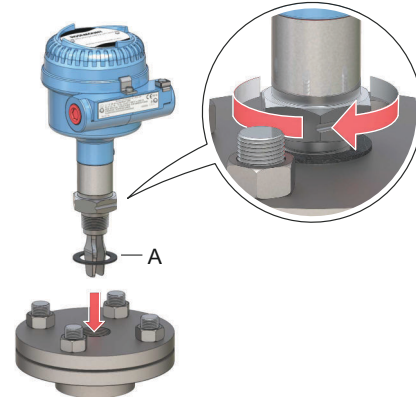

A. Gasket for BSPP (G) threaded connection

3.3.4 Mounting the flanged version

Procedure

1. Lower the level switch into the nozzle.

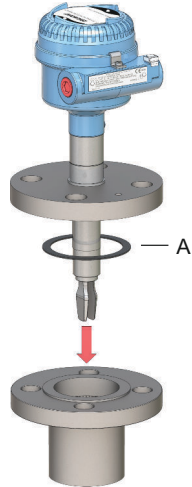

A. Gasket (customer supplied)

2. Tighten the bolts and nuts with sufficient torque for the flange and gasket.

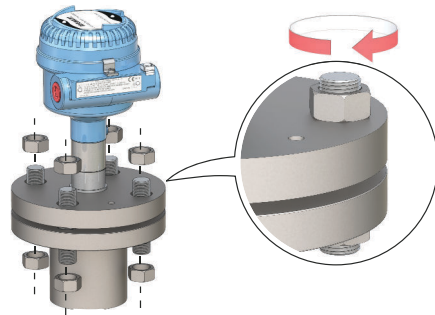

3.3.5 Mounting the Tri Clamp version

Procedure

1. Lower the level switch into the flange face.

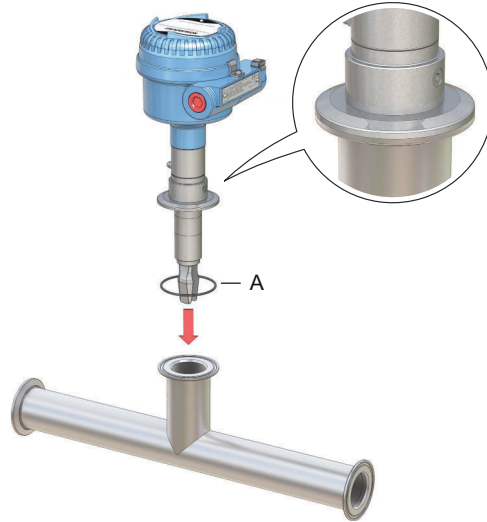

A. Seal (supplied with Tri Clamp)

2. Fit the Tri Clamp.

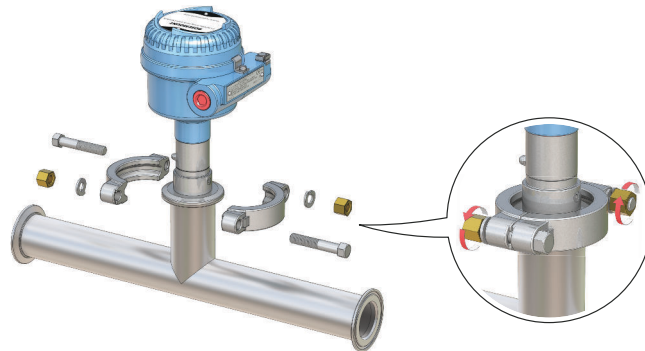

4 Electrical installation

4.1 Safety messages

Instructions and procedures in this section may require special precautions to ensure the safety of the personnel performing the operations. Information that potentially raises safety issues is indicated by a warning symbol () . Refer to the following safety messages before performing an operation preceded by this symbol.

WARNING

Failure to follow safe installation and servicing guidelines could result in death or serious injury.

Ensure the level switch is installed by qualified personnel and in accordance with applicable code of practice.

Use the level switch only as specified in this manual. Failure to do so may impair the protection provided by the level switch.

The weight of a level switch with a heavy flange and extended fork length may exceed 37 lb. (18 kg). A risk assessment is required before carrying, lifting, and installing the level switch.

Repair, e.g. substitution of components, etc. may jeopardize safety and is under no circumstances allowed.

WARNING

Explosions could result in death or serious injury.

Verify the operating atmosphere of the level switch is consistent with the appropriate hazardous locations certifications.

Before connecting a handheld communicator in an explosive atmosphere, ensure the instruments are installed in accordance with intrinsically safe or non-incendive field wiring practices.

In explosion-proof/flameproof and non-incendive installations, do not remove the housing cover when power is applied to the level switch.

The housing cover must be fully engaged to meet flameproof/explosion-proof requirements.

⚠ WARNING

Electrical shock could cause death or serious injury.

Avoid contact with the leads and terminals. High voltage that may be present on leads can cause electrical shock.

Ensure the power to the level switch is off, and the lines to any other external power source are disconnected or not powered while wiring the level switch.

Ensure the wiring is suitable for the electrical current and the insulation is suitable for the voltage, temperature, and environment.

⚠ WARNING

Process leaks could result in death or serious injury.

Ensure the level switch is handled carefully. If the process seal is damaged, gas might escape from the vessel (tank) or pipe.

⚠ WARNING

Physical access

Unauthorized personnel may potentially cause significant damage to and/or misconfiguration of end users' equipment. This could be intentional or unintentional and needs to be protected against.

Physical security is an important part of any security program and fundamental to protecting your system. Restrict physical access by unauthorized personnel to protect end users' assets. This is true for all systems used within the facility.

⚠ CAUTION

Hot surfaces

The flange and process seal may be hot at high process temperatures. Allow to cool before servicing.



4.2 Prepare the electrical connections

4.2.1 Cable selection

Use 26–14 AWG (0.13 to 2.5 mm²) AWG wiring. Twisted-pairs and shielded wiring is recommended for environments with high EMI (electromagnetic interference). Two wires can be safely connected to each terminal screw.

4.2.2 Cable glands/conduits

For intrinsically safe, explosion-proof/flameproof, and dust-proof installations, only use certified cable glands or conduit entry devices. Ordinary location installations can use suitably rated cable glands or conduit entry devices to maintain the Ingress Protection (IP) rating.

Unused conduit entries must always be sealed with a suitably rated blanking/stopping plug.

Note

Do not run signal wiring in conduit or open trays with power wiring or near heavy electrical equipment.

4.2.3 Power supply

The power supply requirements are dependent on the electronics selected.

- Direct load switching electronics: 20 - 60 Vdc or 20 - 264 Vac (50/60 Hz)
- PNP/PLC electronics: 20 - 60 Vdc
- Relay DPCO (Double Pole Changeover) electronics:
20 - 60 Vdc or 20 - 264 Vac (50/60 Hz)
- Fault and alarm relays (2 x SPCO) electronics: 20 - 60 Vdc or 20 - 264 Vac (50/60 Hz)
- NAMUR electronics: 8 Vdc
- 8/16 mA electronics: 24 Vdc

4.2.4 Hazardous areas

When the device is installed in hazardous areas (classified locations), local regulations and the conditions-of-use specified in applicable certificates must be observed. Review the Rosemount 2130 [Product Certifications](#) document for information.

4.2.5 Wiring diagrams

⚠ CAUTION

- Before use, check the cable glands and blanking plugs are suitably rated.
- Isolate supply before connecting the switch or removing the electronics.
- The Protective Earth (PE)  terminal must be connected to an external earthing system.

Note

When replacing a cassette, it is important to re-calibrate.

Direct load switching cassette

Figure 4-1: Direct Load Switching (2-wire) Cassette (Red Label) – Code L

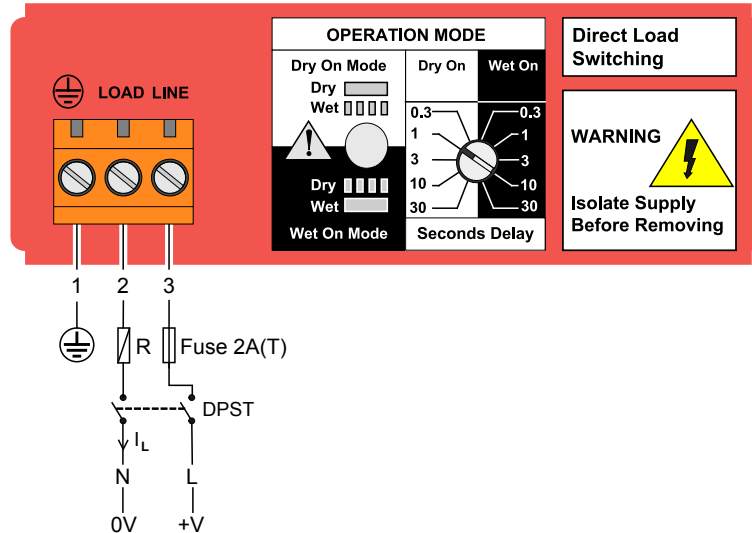

R = External load (must be fitted)

N = Neutral

L = Live

Note

A DPST (Double Pole, Single Throw) on/off switch must be fitted for safe disconnection of the power supply. Fit the DPST switch as near as possible to the level switch. Keep the DPST switch free of obstructions. Label the DPST switch to indicate it is the supply disconnection device for the level switch.

Note

The Rosemount 2130 requires a minimum current to operate (I_{OFF}), which continues to flow when the output is 'off'. If selecting a relay to wire in series with the Rosemount 2130, ensure the drop-out voltage of the relay is greater than the voltage generated across the relay coil when I_{OFF} flows through it.

Table 4-1: Electrical Parameters

Parameter	Value
U	20 - 60 Vdc or 20 - 264 Vac (50/60 Hz)
I_{OFF}	< 4 mA
I_L	20 - 500 mA
I_{PK}	5 A, 40 ms (inrush)

Table 4-2: Direct Load Functions

Mode: dry on, high level alarm		Mode: wet on, low level alarm	
LED on continuously	LED flashes every second	LED on continuously	LED flashes every second

PNP/PLC cassette

Figure 4-2: PNP/PLC (3-wire) Cassette (Yellow Label) – Code P

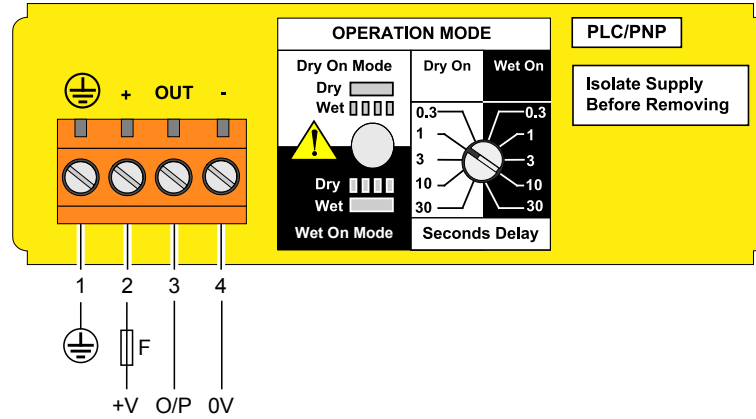

F = Fuse 2A(T)

Table 4-3: Electrical Parameters

Parameter	Value
U	20 - 60 Vdc
I	< 4 mA + I _L
I _{L(OFF)}	< 100 μA
I _{L(MAX)}	0 - 500 mA
I _{PK}	5 A, 40 ms (inrush)
U _{OUT(ON)}	U - 2.5 Vdc (20 °C) U - 2.75 Vdc (-40 to 80 °C)

Table 4-4: PNP/PLC Cassette Functions

Mode: dry on, high level alarm		Mode: wet on, low level alarm	
PLC (positive input)			
PNP dc			
LED			
LED on continuously	LED flashes every second	LED on continuously	LED flashes every second

Relay DPCO cassette (standard version)

Figure 4-3: Relay DPCO Cassette, Standard Version (Green Label) – Code D

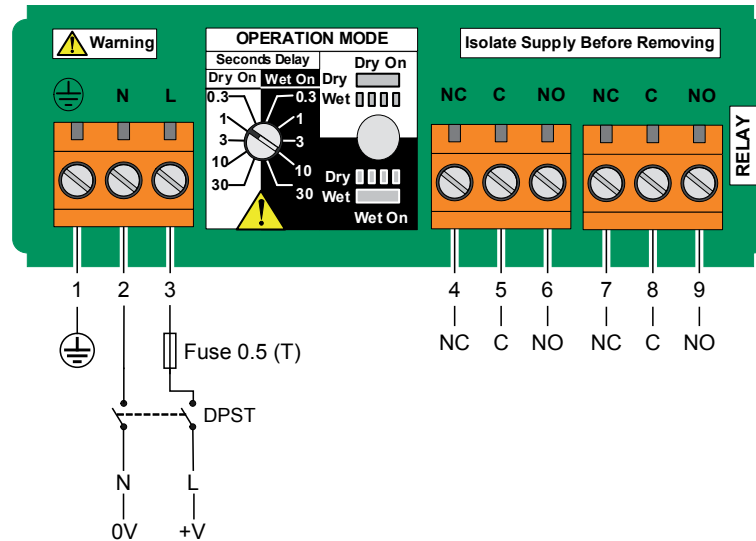

Note

A DPST (Double Pole, Single Throw) on/off switch must be fitted for safe disconnection of the power supply. Fit the DPST switch as near as possible to the level switch. Keep the DPST switch free of obstructions. Label the DPST switch to indicate it is the supply disconnection device for the level switch.

Table 4-5: Electrical Parameters

Parameter	Value
U	20 - 60 Vdc or 20 - 264 Vac (50/60Hz)
I	< 6 mA

Table 4-6: NC, C, and NO Terminals

Parameter		Resistive load	Inductive load
cos ϕ		1	0.4
L/R		0 ms	7 ms
I _{MAX}		5 A	3.5 A
U _{MAX}	ac	250 V	250 V
	dc	30 V	30 V
P _{MAX}	ac	1250 VA	875 VA
	dc	240 W	170 W

Table 4-7: Relay Cassette Functions

Mode: dry on, high level alarm		Mode: wet on, low level alarm	
 NC C NO NC C NO	 NC C NO NC C NO	 NC C NO NC C NO	 NC C NO NC C NO
 LED on continuously	 LED flashes every second	 LED on continuously	 LED flashes every second

Fault and alarm relays (2 x SPCO) cassette

Figure 4-4: Fault and Alarm Relay Outputs Cassette (Light Green Label) – Code D with Option R2264

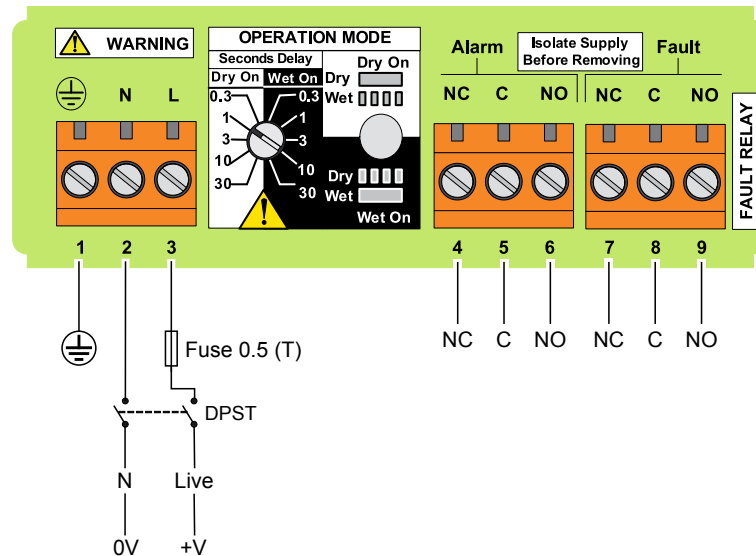

Note

A Double Pole, Single Throw on/off switch must be fitted for safe disconnection of the power supply. Fit the DPST switch as near as possible to the level switch. Keep the DPST switch free of obstructions. Label the DPST switch to indicate it is the supply disconnection device for the level switch.

Table 4-8: Electrical Parameters

Parameter	Value
U	20 - 60 Vdc or 20 - 264 Vac (50/60Hz)
I	< 6 mA

Table 4-9: NC, C, and NO Terminals

Parameter	Resistive load	Inductive load
cos ϕ	1	0.4
L/R	0 ms	7 ms
I _{MAX}	5 A	3.5 A
U _{MAX}	ac	250 V
	dc	30 V
P _{MAX}	ac	1250 VA
	dc	240 W

Table 4-10: Relay Cassette Functions

Mode: dry on, high level alarm				Mode: wet on, low level alarm			
(No alarm)	(No fault)	(Alarm)	(No fault)	(No alarm)	(No fault)	(Alarm)	(No fault)
<p>LED on continuously</p>		<p>LED flashes every second</p>		<p>LED on continuously</p>		<p>LED flashes every second</p>	

NAMUR cassette

Figure 4-5: NAMUR Cassette (Light Blue Label) – Code N

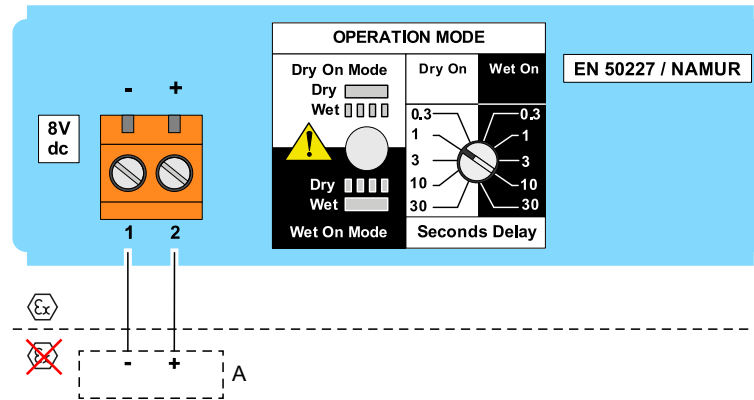

A. A certified intrinsically safe isolating amplifier to IEC 60947-5-6

Note

- This cassette is suitable for Intrinsically Safe (IS) applications and requires a certified isolating barrier. See the Rosemount 2130 [Product Certifications](#) document for Intrinsically Safe approvals.
- This electronics cassette is also suitable for non-hazardous (safe) area applications.
- It can only be interchanged with the 8/16 mA cassette.
- Do not exceed 8 Vdc.

Table 4-11: Electrical Parameters

Parameter	Value
I_{ON}	2.2 - 2.5 mA
I_{OFF}	0.8 - 1.0 mA
I_{FAULT}	< 1.0 mA

Table 4-12: NAMUR Cassette Functions

Mode: dry on, high level alarm		Mode: wet on, low level alarm	
(-) (+) 1 2 > 2.2 mA 	(-) (+) 1 2 < 1.0 mA 	(-) (+) 1 2 > 2.2 mA 	(-) (+) 1 2 < 1.0 mA
 LED on continuously	 LED flashes every second	 LED on continuously	 LED flashes every second

8/16 mA cassette

Figure 4-6: 8/16 mA Cassette (Dark Blue Label) – Code M

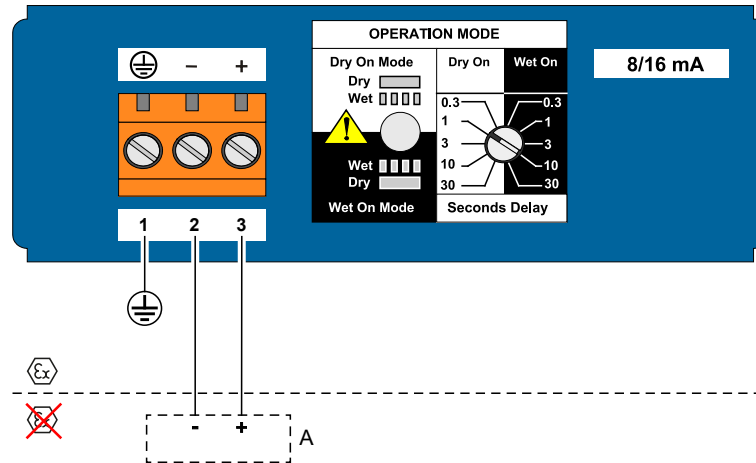

A. A certified intrinsically safe isolating amplifier to IEC 60947-5-6

Note

- This cassette is suitable for Intrinsically Safe (IS) applications and requires a certified isolating barrier. See the Rosemount 2130 [Product Certifications](#) document for Intrinsically Safe approvals.
- This electronics cassette is also suitable for non-hazardous (safe) area applications. In this case, $U = 11 - 36 \text{ Vdc}$.
- It can only be interchanged with a NAMUR cassette.

Table 4-13: Electrical Parameters

Parameter	Value
U	24 Vdc Nominal
I_{ON}	15 - 17 mA
I_{OFF}	7.5 - 8.5 mA
I_{FAULT}	< 3.7 mA

Table 4-14: 8/16 mA Cassette Functions

Mode: dry on, high level alarm		Mode: wet on, low level alarm	
<p>LED on continuously</p>	<p>LED flashes every second</p>	<p>LED on continuously</p>	<p>LED flashes every second</p>

Fault condition detection (self-check mode only)

When a fault condition is detected in the self-check operating mode, the heartbeat LED flashes once every half a second and every third flash is missed. The output from the level switch will then be as [Table 4-15](#).

Table 4-15: Fault Condition Detection (Self-check Mode Only)

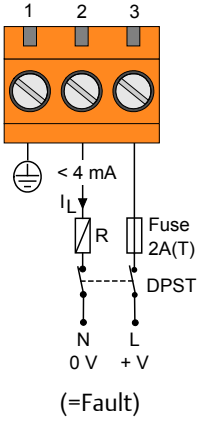
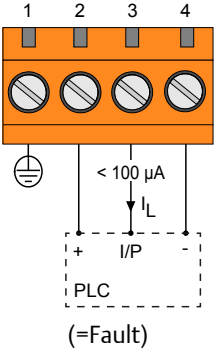
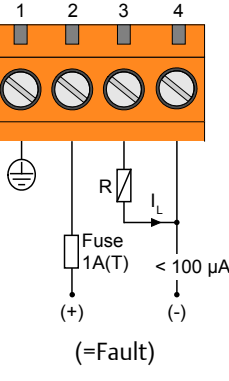
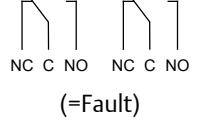
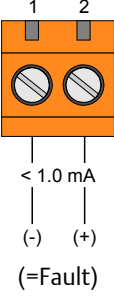
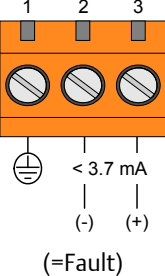
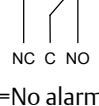
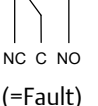
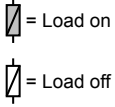
Direct load	PLC	PNP dc
 <p>(=Fault)</p>	 <p>(=Fault)</p>	 <p>(=Fault)</p>
DPCO relay	NAMUR	8/16 mA
 <p>(=Fault)</p>	 <p>(=Fault)</p>	 <p>(=Fault)</p>
Fault and alarm (2 x SPCO) relays		
<p>Alarm relay</p>  <p>(=No alarm)</p>	<p>Fault relay</p>  <p>(=Fault)</p>	 <p>▭ = Load on ▭ = Load off</p>

4.2.6 Grounding

Make sure grounding is done according to national and local electrical codes. Failure to do so may impair the protection provided by the equipment.

Signal cable shield grounding

Make sure the instrument cable shield is:

- Trimmed close and insulated from touching the housing.

- Continuously connected throughout the segment.
- Connected to a good earth ground at the power supply end.

Figure 4-7: Signal Cable Shield Grounding at Power Supply End

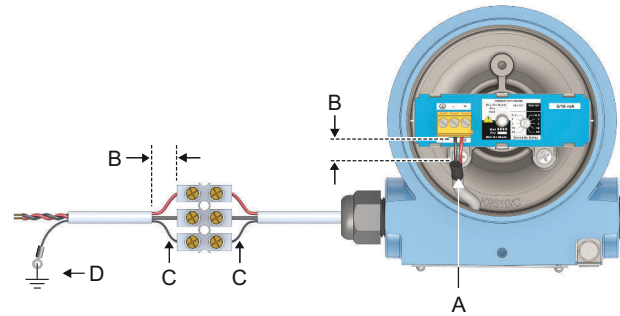

- A. Trim shield and insulate
- B. Minimize distance
- C. Trim shield
- D. Connect shield back to the power supply ground

Grounding the housing

The most effective grounding method for the metal housing is a direct connection to earth ground with minimal impedance. Housings with NPT conduit entries do not have an earth ground point and must use the fork earth.

Figure 4-8: Ground Screws

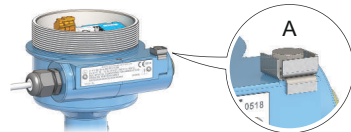

- A. External ground screw

4.3 Connect wiring and power up

Procedure

1. ⚠ Verify the power supply is disconnected.

2. Remove the field terminals cover.

In an explosion-proof/flameproof installation, do not remove the level switch cover when power is applied to the unit. The cover must also not be removed in extreme environmental conditions.

Versions of the Rosemount 2130 with explosion-proof/flameproof approvals have a cover-lock to be undone first.

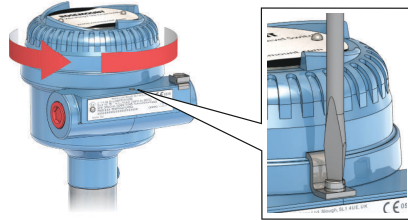

3. Remove the plastic plugs.



4. Pull cables through the cable gland/conduits.

Cassettes with a single terminal only require one cable.

Identification of thread size and type:

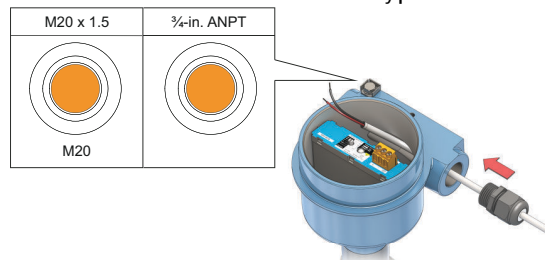

5. Connect the cable wires (see [Wiring diagrams](#) for other cassettes).

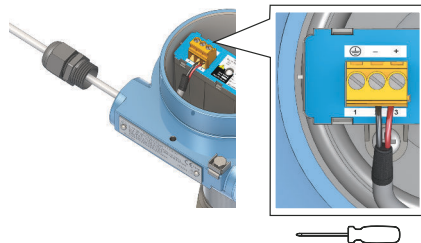

6. Ensure proper grounding.

7. Tighten the cable glands.
Apply PTFE tape or other sealant to the threads.

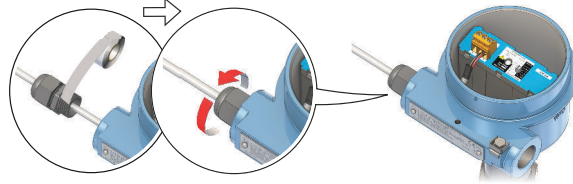

Note

Make sure to arrange the wiring with a drip loop.



8. Plug and seal the unused conduit connection to avoid moisture and dust accumulation inside the housing.
Apply PTFE tape or other sealant to the threads.

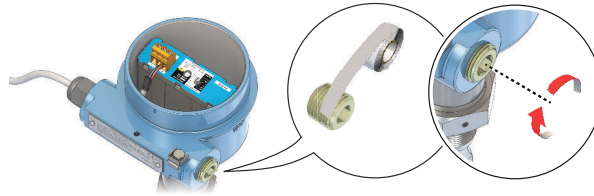

9. Attach and tighten the cover.
Make sure the cover is fully engaged.

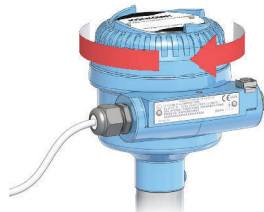

10. ⚠ Required for explosion-proof/flameproof installations only:
The cover must be fully engaged to comply with explosion-proof requirements.
11. Re-lock the cover.

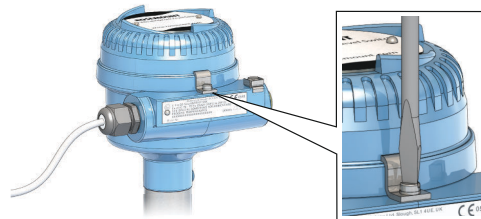

12. Connect the power supply.

5 Operation

5.1 Output mode and time delay

All electronics cassettes have a rotating switch for setting the output to be "Dry On" (on when the fork is sufficiently dry) or "Wet On" (on when the fork is sufficiently wet).

The electronics uses hysteresis to help prevent constant switching of the output from dry-to-wet and wet-to-dry states due to splashing or intermediate conditions. To further prevent false switching, the rotating switch also sets a time delay of up to 30 seconds before the output changes.

A small cut-out in the rotating switch indicates the present mode and time delay.

Figure 5-1: Top-down View: Example Cassette Inside Housing

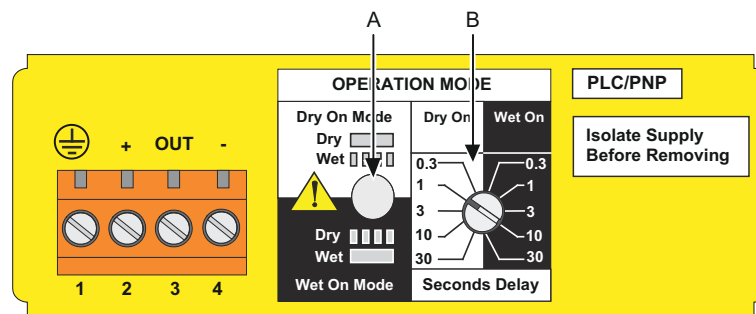

- A. 'Heartbeat' LED
- B. Rotating switch for setting output mode and time delay

The recommended mode for high level alarm installations is the "Dry On" mode (Figure 5-2).

Figure 5-2: Typical Settings for High Level Applications

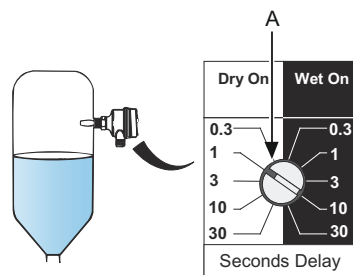

- A. Mode "Dry On" and 1 second time delay

The "Wet On" mode is recommended for low level alarm installations (Figure 5-3).

Figure 5-3: Typical Settings for Low Level Applications

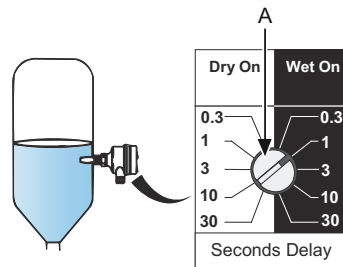

A. Mode “Wet On” and 1 second time delay

5.1.1 Set the mode switch and switching time delay

Procedure

1. Select “Dry on” or “Wet on” mode.
2. Select 0.3, 1, 3, 10, or 30 seconds for the delay before switching output state.

Note

There is a five second delay before changes to the mode and time delay become active.

5.2 LED indication status

Table 5-1 shows the different operation statuses and how they are indicated by the LED.

Table 5-1: LED Indications

	LED flash rate	Switch status
	Continuous	Output state is on.
	1 every ½ second, and every third flash is missing.	External damage to forks, corroded forks, internal wire damage, or internal sensor damage (self-check mode only).
	1 every second	Output state is off.
	1 every 2 seconds	Uncalibrated.
	1 every 4 seconds	Load fault; load current too high; load short circuit.
	2 times / second	Indication of successful calibration.
	3 times / second	Internal PCB fault.
	Off	Problem (e.g. supply).

5.3 Set the operating mode

All versions of the level switch have two operating modes:

- Normal mode (red LED)
- Self-check mode (yellow LED)

Procedure

1. Set the mode switch to 1 s Dry On (or 1 s Wet On).
2. Wait for 10 seconds.
3. Move the mode switch to 30 s Dry On (or 30 s Wet On), and wait for 1 second before moving the mode switch back to 1 s Dry On (or 1 s Wet On). This should be completed within 3 seconds.

Figure 5-4: Change Operating Mode

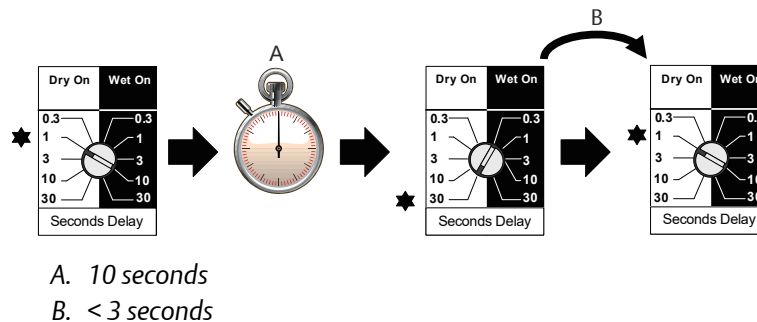

5.3.1 LED indication for operating modes

Different LED colors indicate the operating mode (Table 5-2).

Table 5-2: LED Indications – Operating Mode

LED color	Operating modes	Description of mode
Red	Normal	When the LED is red and flashing, it indicates that the Rosemount 2130 may be uncalibrated, successfully calibrated, has an electrical load problem, or has an internal PCB fault.
Yellow	Self-check	When the LED is yellow and flashing, it indicates the same as Normal mode, but also indicates there could be external damage to forks, corroded forks, or internal sensor damage. Note For SIL 2 compliance, self-check mode must be enabled.

Related information

[Rosemount 2130 Safety Manual](#)

6 Service and troubleshooting

6.1 Safety messages

Instructions and procedures in this section may require special precautions to ensure the safety of the personnel performing the operations. Information that potentially raises safety issues is indicated by a warning symbol () . Refer to the following safety messages before performing an operation preceded by this symbol.

WARNING

Failure to follow safe installation and servicing guidelines could result in death or serious injury.

Ensure the level switch is installed by qualified personnel and in accordance with applicable code of practice.

Use the level switch only as specified in this manual. Failure to do so may impair the protection provided by the level switch.

The weight of a level switch with a heavy flange and extended fork length may exceed 37 lb. (18 kg). A risk assessment is required before carrying, lifting, and installing the level switch.

Repair, e.g. substitution of components, etc. may jeopardize safety and is under no circumstances allowed.

WARNING

Explosions could result in death or serious injury.

Verify the operating atmosphere of the level switch is consistent with the appropriate hazardous locations certifications.

Before connecting a handheld communicator in an explosive atmosphere, ensure the instruments are installed in accordance with intrinsically safe or non-incendive field wiring practices.

In explosion-proof/flameproof and non-incendive installations, do not remove the housing cover when power is applied to the level switch.

The housing cover must be fully engaged to meet flameproof/explosion-proof requirements.

⚠ WARNING

Electrical shock could cause death or serious injury.

Avoid contact with the leads and terminals. High voltage that may be present on leads can cause electrical shock.

Ensure the power to the level switch is off, and the lines to any other external power source are disconnected or not powered while wiring the level switch.

Ensure the wiring is suitable for the electrical current and the insulation is suitable for the voltage, temperature, and environment.

⚠ WARNING

Process leaks could result in death or serious injury.

Ensure the level switch is handled carefully. If the process seal is damaged, gas might escape from the vessel (tank) or pipe.

⚠ WARNING

Physical access

Unauthorized personnel may potentially cause significant damage to and/or misconfiguration of end users' equipment. This could be intentional or unintentional and needs to be protected against.

Physical security is an important part of any security program and fundamental to protecting your system. Restrict physical access by unauthorized personnel to protect end users' assets. This is true for all systems used within the facility.

⚠ CAUTION

Hot surfaces

The flange and process seal may be hot at high process temperatures. Allow to cool before servicing.



6.2 Magnetic test point

A magnetic test point is marked on the side of the housing to allow a functional test of the Rosemount 2130 in the overall system. By touching a magnet to the target, the output from the level switch will change state while the magnet is present.

Figure 6-1: Magnetic Test-point Function

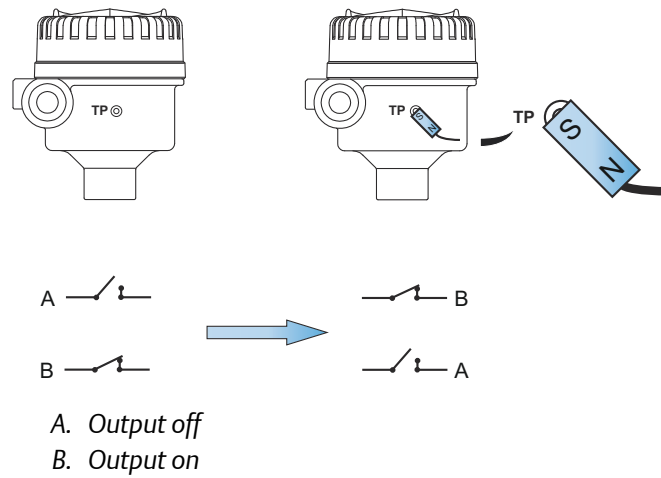

6.3 Visual inspection

Visually examine the level switch and do not use if it is damaged. Check:

- The housing cover, cable glands, and blanking plugs are fitted securely.

Figure 6-2: Visual Inspection

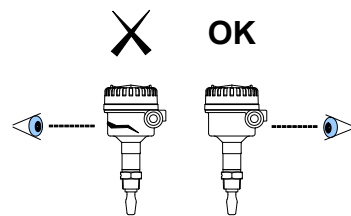

6.4 Maintenance

Figure 6-3: Maintenance

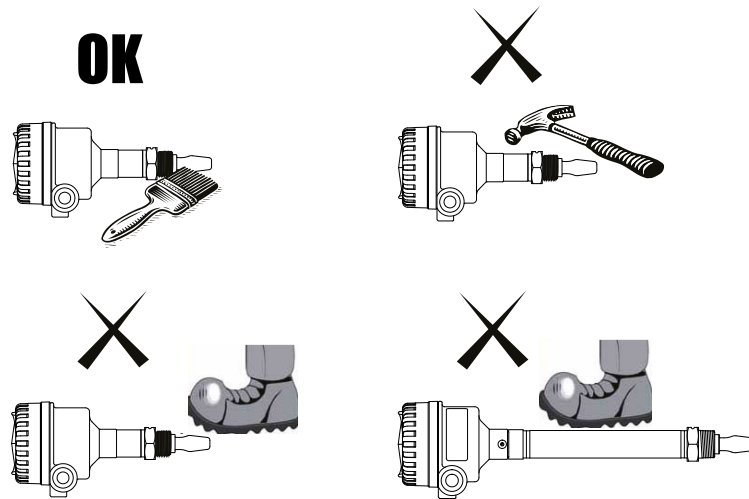

Note

Only use a soft type brush for cleaning.

6.5 Troubleshooting

6.5.1 Does not switch

Symptom or indication

LED is not lit, no power.

Recommended actions

1. Check the power supply.
2. Check the load on direct load switching electronics model.

Symptom or indication

LED is flashing three times per second.

Recommended actions

Contact Emerson to report an internal PCB fault is being indicated.

Symptom or indication

LED is flashing once every two seconds.

Recommended actions

Contact Emerson to report an uncalibrated device is being indicated.

Symptom or indication

LED is flashing once every four seconds.

Recommended actions

Check the electrical installation for a load fault (current is too high or a short-circuit).

Symptom or indication

Visual inspection found fork damage.

Recommended actions

Contact Emerson to report the damage and discuss how to get a replacement.

Symptom or indication

Visual inspection found thick encrustation on the forks.

Recommended actions

Carefully clean the fork.

Symptom or indication

There is always a five second delay after changing the mode or delay.

Recommended actions

This is a normal function when making any changes to the settings.

Related information

[LED indication for operating modes](#)

6.5.2 Incorrect switching

Symptom or indication

Dry = On, Wet = On is set incorrectly.

Recommended actions

Set the correct mode on the electronics cassette.

6.5.3 Faulty switching

Symptom or indication

Turbulence.

Recommended actions

Set a longer switching time delay.

Symptom or indication

Excessive electrical noise.

Recommended actions

Suppress the cause of the interference.

Symptom or indication

Cassette has been fitted from another level switch.

Recommended actions

Fit the factory supplied cassette and then calibrate.

6.6 Spare parts

See the Rosemount 2130 [Product Data Sheet](#) for the latest information about spare parts.

6.7 Replacement and calibration of cassettes

When replacing a damaged or faulty electronics cassette, it is necessary to calibrate the replacement cassette to the operating frequency of the fork sensor.

6.7.1 Replace the cassette

Prerequisites

If this replacement is taking place in a hazardous area, only qualified personnel should perform the replacement. All work in hazardous areas must be carried out in accordance to national and local codes of practice.

On Intrinsically Safe (I.S.) approved versions of the level switch, it is recommended that replacement and calibration is performed in a non-hazardous (safe) area.

Note

- In I.S. applications, NAMUR cassettes can only be replaced with NAMUR cassettes, and 8/16 mA cassettes can only be replaced by 8/16 mA cassettes.
- Non-I.S. cassettes can be interchanged with other non-I.S. cassettes, but the new label must be fitted and the original part number transferred to the new label.
- Before starting the replacement and calibration procedure, ensure that any controlled process will not be adversely affected.

Procedure

1. Isolate and disconnect the power to the Rosemount 2130, and insulate the ends of the wires as a safety precaution.
There may be more than one power source connected to a relay cassette.
2. Remove the housing cover and disconnect the wires from the cassette.
Make a note of the connections and mode switch position (see [Figure 6-4](#)).

Figure 6-4: Mode Switch Setting (Existing Cassette)

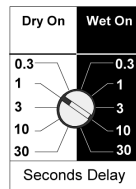

This is an example of how the existing cassette may look. Here, the mode switch is set to “Dry On” with a one second delay.

Take note of the actual setting.

SETTING IS: _____

3. Remove and retain the two fixing screws from the base of the cassette, and then unplug the cassette.
4. Plug in the replacement cassette, secure it with the two screws.
5. Reconnect the wiring.
6. Set the mode switch to “Wet On” with a one second delay, ready for calibration (see [Figure 6-5](#)).

Figure 6-5: Mode Switch Setting (Replacement Cassette)

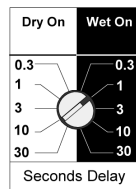

7. Reconnect the power supplies to the Rosemount 2130.

6.7.2 Calibrate the replacement cassette

Prerequisites

Some of the calibration sequence steps are time-dependent and must be carried out within the noted times. The purpose of the time dependency and switching sequence is to prevent an accidental calibration from occurring.

Verify:

- The sensor forks are clean and dry.
- The mode switch is set to “Wet On” with the time delay set to one second.

Procedure

1. Verify the 'heartbeat' LED is flashing at a rate of one flash per second. Proceed to [Step 5](#) if it is on continuously.

2. Apply a magnet to the test-point.
After a one second delay, the LED will be lit continuously.
3. Within one second, rotate the mode switch two steps clockwise.
The LED will go out within two seconds.
4. Within three seconds, rotate the mode switch two steps counter-clockwise.
Proceed to [Step 8](#).
After a two second delay, the LED should start flashing twice per second.
5. Apply a magnet to the test-point.
After a one second delay, the LED will flash once every second.
6. Within one second, rotate the mode switch two positions clockwise.
The LED will go out within two seconds.
7. Within three seconds, rotate the mode switch two steps counter-clockwise.
After a two second delay, the LED should start flashing twice per second.
8. If the LED is flashing twice per second, the calibration has worked correctly.
 - a) Remove the magnet from the test-point.
 - b) After a one second delay, the unit will return to normal operation. Proceed to [Step 11](#).
9. If the LED is flashing once per second or it is on continuously, the calibration has failed:
 - a) Remove the magnet from the test-point.
 - b) Wait ten seconds, and then re-try from [Step 2](#).
10. If the LED is not lit (after the two seconds delay in [Step 7](#)):
 - a) Check the sensor forks are clean and dry.
 - b) Check if anything is jamming or touching the sensor forks.
 - c) Contact Customer Support at Emerson if no fault is found.
11. Set the mode switch to the original setting and wait five seconds.
12. Replace the housing cover and check that the system works.

Related information

[Magnetic test point](#)

6.8 Opening the lid (cover)

Before opening the lid for maintenance reasons observe following items:

- Do not remove the lid while circuits are live.
- No dust deposits or whirlings are present.
- No rain can enter into the housing.

6.9 Service support

To expedite the return process outside of the United States, contact the nearest Emerson representative.

Within the United States, call the Emerson Instrument and Valve Response Center using the 1-800-654-RSMT (7768) toll-free number. This center, available 24 hours a day, will assist you with any needed information or materials.

The center will ask for product model and serial numbers, and will provide a Return Material Authorization (RMA) number. The center will also ask for the process material to which the product was last exposed.

⚠ CAUTION

Individuals who handle products exposed to a hazardous substance can avoid injury if they are informed of and understand the hazard. Returned products must include a copy of the required Safety Data Sheet (SDS) for each substance.

Emerson Instrument and Valve Response Center representatives will explain the additional information and procedures necessary to return goods exposed to hazardous substances.

A Specifications and reference data

A.1 General

A.1.1 Measuring technology

Vibrating fork

A.1.2 Applications

Point level detection in liquid process mediums, including coating liquids, aerated liquids, and slurries. Suitable for horizontal and vertical installation.

A.2 Physical specifications

A.2.1 Material selection

Emerson provides a variety of Rosemount products with various product options and configurations, including materials of construction that can be expected to perform well in a wide range of applications. The Rosemount product information presented is intended as a guide for the purchaser to make an appropriate selection for the application. It is the purchaser's sole responsibility to make a careful analysis of all process parameters (such as all chemical components, temperature, pressure, flow rate, abrasives, contaminants, etc.), when specifying product, materials, options, and components for the particular application. Emerson is not in a position to evaluate or guarantee the compatibility of the process fluid or other process parameters with the product, options, configuration, or materials of construction selected.

A.2.2 Housing/Enclosure

Table A-1: Housing / Enclosure Specifications

Housing code	A-2	A-9	S-2	S-9
Housing material	Aluminum Alloy ASTM B85 A360.0		316C12 Stainless Steel	
Rotational	No	No	No	No
Paint	Polyurethane		Not applicable	
LED window	None		None	
Conduit entry	M20	½-in. NPT	M20	¾-in. NPT
Ingress protection	IP66/67 to EN60529, NEMA® 4X		IP66/67 to EN60529, NEMA 4X	

A.2.3 Process wetted connections

Connections

Threaded, Tri Clamp, and flanged process connection options.

Materials

- 316/316L stainless steel (1.4401/1.4404 dual-certified)
- Alloy C (UNS N10002) and Alloy C-276 (UNS N10276)
Available for flanged, and selected threaded process connections (¾-in. and 1-in. BSPT (R), and ¾-in. and 1-in. NPT).
- ECTFE co-polymer coated 316/316L Stainless Steel (1.4401/1.4404 dual certified)
Available only for flanged process connections.
- Gasket material for ¾-in. and 1-in. BSPP (G) is non-asbestos BS7531 Grade X carbon fiber with rubber binder.
Gaskets are not supplied with flanged process connections.

A.2.4 Customer specified fork length

Table A-2: Extended Fork Lengths

Process connection	Minimum	Maximum ⁽¹⁾
¾-in. threaded	3.8 in. (95 mm)	157.5 in. (4000 mm)
1-in. threaded	3.7 in. (94 mm)	157.5 in. (4000 mm)
Flanged	3.5 in. (89 mm)	157.5 in. (4000 mm)
Tri Clamp	4.1 in. (105 mm)	157.5 in. (4000 mm)

(1) The maximum extended length is 157.5 in. (4000 mm), except for ECTFE co-polymer coating and polished process connection options which have a maximum length of 59.1 in. (1500 mm) and 39.4 in. (1000 mm) respectively.

A.3 Performance specifications

A.3.1 Hysteresis (water)

0.1 in. (2.5 mm)

A.3.2 Switching point (water)

0.5 in. (13 mm) from fork tip if mounted vertically.

0.5 in. (13 mm) from the fork edge if mounted horizontally.

The switching point varies with different liquid densities.

A.3.3 Liquid density requirements

Minimum standard density is 37.5 lb/ft³ (600 kg/m³).

Minimum density is 31.2 lb/ft³ (500 kg/m³ when ordered with the Low Density Range option.

A.3.4 Liquid viscosity range

Up to 10000 cP (centiPoise) when operating in the Normal mode.

Up to Up to 1000 cP (centiPoise) when operating in Self-check mode.

A.3.5 Solids content and coating

The maximum recommended diameter of solid particles in the liquid is 0.2 in. (5 mm) when used in Normal mode only. Avoid bridging of forks (fork-to-fork).

A.3.6 Operating modes

Table A-3: Operating Modes

Fault conditions detected	Normal mode	Self-check mode
PCB control circuit corruption	Yes	Yes
External damage to fork	No	Yes
Internal damage to sensor	No	Yes
Excessive corrosion	No	Yes
Over-temperature	No	Yes

A.4 Electrical specifications

A.4.1 Protections

Table A-4: Electrical Protections

Protection	Availability on Cassettes
Polarity insensitive	Direct Load and Relay electronics
Over-current protection	Direct Load and PNP/PLC electronics
Short-circuit protection	Direct Load and PNP/PLC electronics
Load-missing protection	Direct Load and PNP/PLC electronics
Surge protection (to IEC61326)	All electronics

A.4.2 Terminal connection (wire diameter)

Minimum 26 AWG, maximum 14 AWG (0.13 to 2.5 mm²). Note national regulations.

A.4.3 Conduit plugs/cable glands

Conduit entries for explosion-proof areas are shipped with one Exd plug (loose in bag) and two dust caps fitted. Use suitably rated cable glands. Unused conduit entries must be sealed with a suitably rated blanking plug. Local codes and regulations must be complied with.

A.5 Functional specifications

A.5.1 Switching delay

User-selectable 0.3, 1, 3, 10, 30 seconds delay for dry-to-wet and wet-to-dry switching.

A.5.2 Switching mode

User selectable switching mode (Dry=on or Wet=on).

A.6 Environmental specifications

A.6.1 Maximum operating altitude

6562 ft. (2000 m)

A.6.2 Maximum operating pressures

Figure A-1: Process Pressure

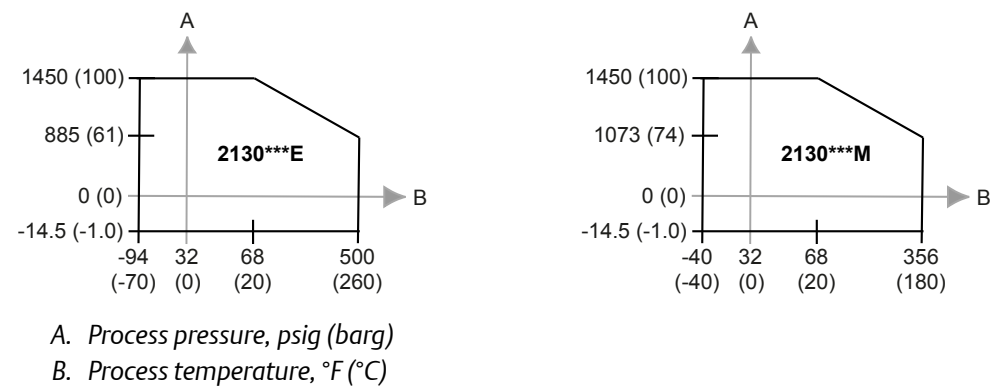

The final rating depends on the type of process connection.

Threaded connection

See Figure A-1.

Tri Clamp connection

435 psig (30 barg)

Flanged connection

The maximum operating pressure is the lower of the process pressure (Figure A-1) and flange pressure rating (see Table A-5).

Table A-5: Maximum Flange Pressure Rating

Standard	Class/Rating	Stainless steel flanges
ASME B16.5	Class 150	275 psig ⁽¹⁾
ASME B16.5	Class 300	720 psig ⁽¹⁾
ASME B16.5	Class 600	1440 psig ⁽¹⁾
EN1092-1	PN 10/16	16 barg ⁽²⁾
EN1092-1	PN 25/40	40 barg ⁽²⁾
EN1092-1	PN 63	63 barg ⁽²⁾
EN1092-1	PN 100	100 barg ⁽²⁾

(1) At 100 °F (38 °C), the pressure rating decreases with an increasing process temperature.

(2) At 122 °F (50 °C), the pressure rating decreases with an increasing process temperature.

A.6.3

Maximum and minimum operating temperatures

See Figure A-2 for the maximum and minimum operating temperatures.

The ambient temperature for a 8/16 mA cassette is limited to 158 °F (70 °C) in dust applications.

Figure A-2: Operating Temperature

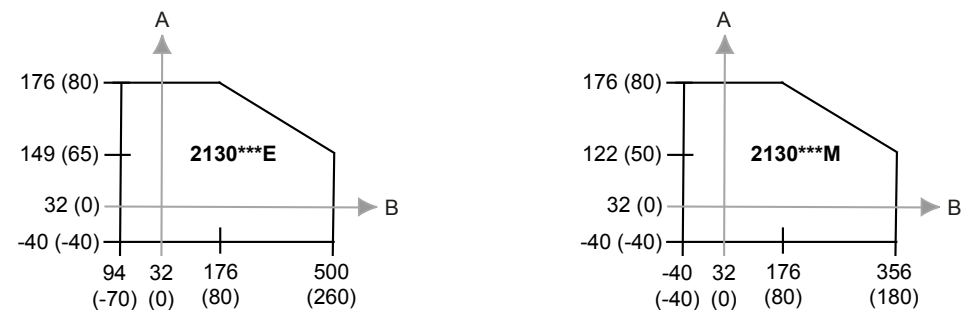

A. Ambient Temperature, °F (°C)

B. Process Temperature, °F (°C)

A.7 Dimensional drawings

See the Rosemount 2130 [web page](#) for all hygienic dimensional drawings.

Figure A-3: $\frac{3}{4}$ - and 1-in. Threaded Mounting (Standard Length)

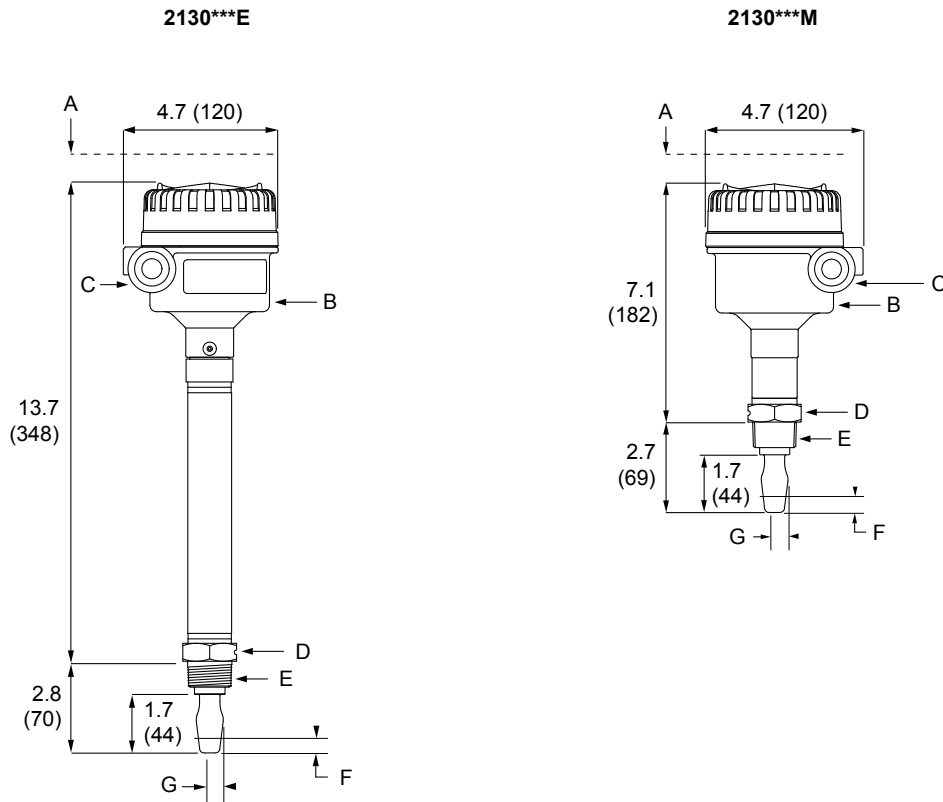

- A. Allow 1.2 (30) clearance to remove cover
- B. Aluminum or stainless steel housing
- C. Cable entry M20 x 1.5 or $\frac{3}{4}$ -in. NPT
- D. 1.6 (40) A/F hexagon
- E. $\frac{3}{4}$ - or 1-in. thread
- F. 0.5 (13) switchpoint (when mounted vertically)
- G. 0.5 (13) switchpoint (when mounted horizontally)

Dimensions are in inches (millimeters).

Figure A-4: 3/4- and 1-in. Threaded Mounting (Extended Length)

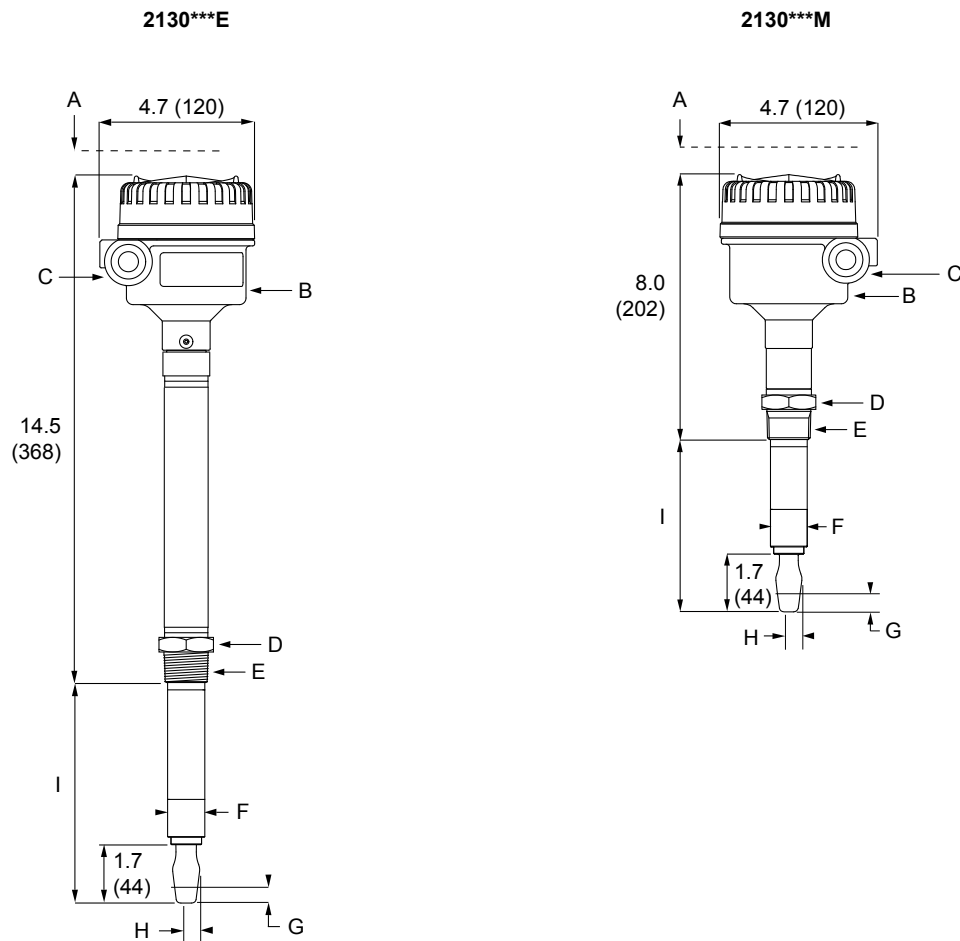

- A. Allow 1.2 (30) clearance to remove cover
- B. Aluminum or stainless steel housing
- C. Cable entry M20 x 1.5 or 3/4-in. NPT
- D. 1.6 (40) A/F hexagon
- E. 3/4- or 1-in. thread
- F. Ø1.1 (28) for 1-in. thread; Ø0.9 (23) for 3/4-in. thread
- G. 0.5 (13) switchpoint (when mounted vertically)
- H. 0.5 (13) switchpoint (when mounted horizontally)
- I. Customer specified fork length (see [Table A-2](#))

Dimensions are in inches (millimeters).

Figure A-5: Flange Mounting (Standard Length)

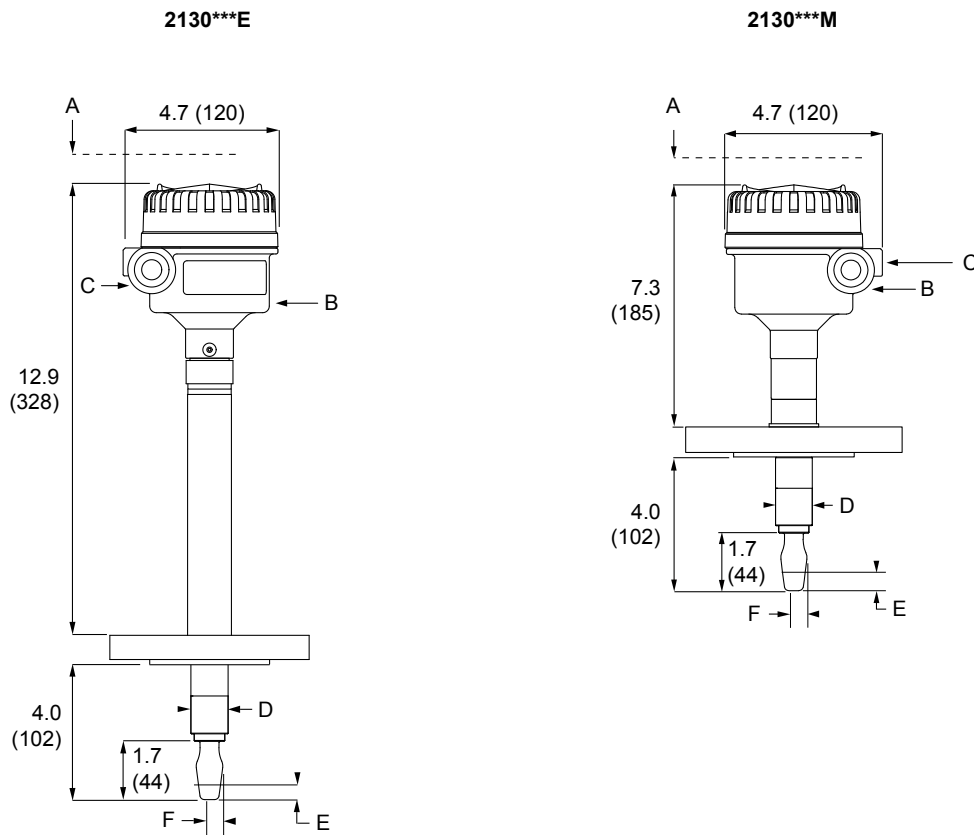

- A. Allow 1.2 (30) clearance to remove cover
- B. Aluminum or stainless steel housing
- C. Cable entry M20 x 1.5 or 3/4-in. NPT
- D. Ø1.1 (28) for 1/2 -in. or larger flange; Ø0.9 (23) for up to 1-in. flange; Ø0.95 (24) for 1-in. coated flange
- E. 0.5 (13) switchpoint (when mounted vertically)
- F. 0.5 (13) switchpoint (when mounted horizontally)

Dimensions are in inches (millimeters).

Figure A-6: Flange Mounting (Extended Length)

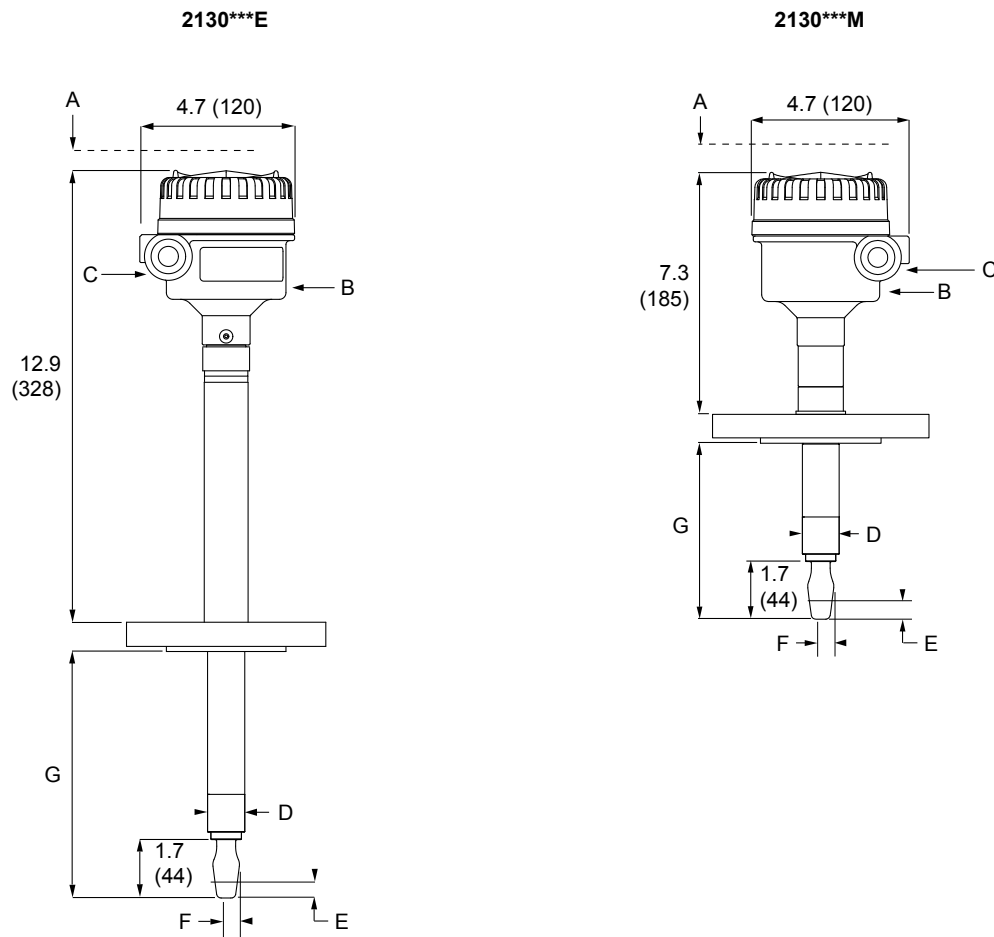

- A. Allow 1.2 (30) clearance to remove cover
- B. Aluminum or stainless steel housing
- C. Cable entry M20 x 1.5 or ¾-in. NPT
- D. Ø1.1 (28) for 1½-in. or larger flange; Ø0.9 (23) for up to 1-in. flange; Ø0.95 (24) for 1-in. coated flange
- E. 0.5 (13) switchpoint (when mounted vertically)
- F. 0.5 (13) switchpoint (when mounted horizontally)
- G. Customer specified fork length (see [Table A-2](#))

Dimensions are in inches (millimeters).

For more information: [Emerson.com](https://www.emerson.com)

©2022 Emerson. All rights reserved.

Emerson Terms and Conditions of Sale are available upon request. The Emerson logo is a trademark and service mark of Emerson Electric Co. Rosemount is a mark of one of the Emerson family of companies. All other marks are the property of their respective owners.

ROSEMOUNT™

