

# Rosemount™ 2460 System Hub

for tank gauging systems



## NOTICE

Read this manual before working with the product. For personal and system safety, and for optimum product performance, ensure you thoroughly understand the contents before installing, using, or maintaining this product. For equipment service or support needs, contact your local Emerson representative.

---

### Spare Parts

Any substitution of non-recognized spare parts may jeopardize safety. Repair, e.g. substitution of components etc, may also jeopardize safety and is under no circumstances allowed.

Rosemount Tank Radar AB will not take any responsibility for faults, accidents, etc caused by non-recognized spare parts or any repair which is not made by Rosemount Tank Radar AB.

## NOTICE

The products described in this document are NOT designed for nuclear-qualified applications. Using non-nuclear qualified products in applications that require nuclear-qualified hardware or products may cause inaccurate readings. For information on Rosemount nuclear-qualified products, contact your local Emerson Sales Representative.

---

# Contents

<b>Chapter 1</b>	<b>Introduction.....</b>	<b>7</b>
	1.1 Safety messages.....	7
	1.2 Symbols.....	8
	1.3 Manual overview.....	8
	1.4 Technical documentation.....	10
	1.5 Product certifications.....	13
	1.6 Service support.....	13
	1.7 Product recycling/disposal.....	13
	1.8 Packing material.....	13
<b>Chapter 2</b>	<b>Overview.....</b>	<b>15</b>
	2.1 Introduction.....	15
	2.2 Communication.....	16
	2.3 Components.....	18
	2.4 System overview.....	22
	2.5 Installation procedure.....	28
<b>Chapter 3</b>	<b>Installation.....</b>	<b>31</b>
	3.1 Section overview.....	31
	3.2 Safety messages.....	31
	3.3 Installation considerations.....	32
	3.4 Mechanical installation.....	34
	3.5 Electrical installation.....	37
<b>Chapter 4</b>	<b>Configuration.....</b>	<b>59</b>
	4.1 Overview.....	59
	4.2 Safety messages.....	59
	4.3 Setting up a Rosemount 2460 System Hub.....	60
	4.4 Inventory calculation configuration.....	98
	4.5 Strapping table configuration.....	106
	4.6 Floating roof monitoring.....	108
<b>Chapter 5</b>	<b>Operation.....</b>	<b>113</b>
	5.1 Overview.....	113
	5.2 Safety messages.....	113
	5.3 Light Emitting Diodes.....	113
	5.4 Redundancy operation.....	118
<b>Chapter 6</b>	<b>Service and troubleshooting.....</b>	<b>125</b>
	6.1 Safety messages.....	125
	6.2 Tools.....	126
	6.3 Troubleshooting.....	126
	6.4 Exchanging a modem card.....	129
	6.5 Exchanging the terminal board.....	131
	6.6 Replacing the power supply unit.....	133

6.7	Using the web interface.....	135
6.8	User settings.....	140
6.9	View tank.....	141
6.10	Ports statistics.....	144
6.11	Setup a communication log.....	145
6.12	Modbus TCP configuration.....	150
6.13	User defined Modbus.....	151
6.14	Modbus TCP statistics.....	152
6.15	Time.....	153
6.16	Ports.....	154
6.17	Network.....	158
6.18	Diagnostics.....	168
6.19	Restore to factory defaults.....	171
6.20	Create system backup.....	172
6.21	Configuration recovery.....	175
6.22	Firmware upgrade.....	177
6.23	License upgrade.....	181
6.24	Redundancy.....	184
6.25	Fuses.....	187
6.26	Write protection.....	188
6.27	Replacing the backup battery.....	190
6.28	Setting the real-time clock.....	191
6.29	Maintenance.....	192
6.30	Modem cards.....	193
6.31	Simulation.....	200
<b>Appendix A</b>	<b>Specifications and reference data.....</b>	<b>203</b>
A.1	Communication/configuration specifications.....	203
A.2	Electrical specifications.....	209
A.3	Mechanical specifications.....	209
A.4	Environmental specifications.....	210
A.5	Additional specifications.....	210
A.6	Dimensional drawings.....	211
A.7	Ordering information.....	213
<b>Appendix B</b>	<b>Enraf® device configuration.....</b>	<b>221</b>
B.1	Tank Database configuration for Enraf® devices.....	221
B.2	Advanced Enraf configuration.....	223
<b>Appendix C</b>	<b>Servo commands.....</b>	<b>225</b>
C.1	Send a servo command.....	225
C.2	Servo states.....	229
C.3	Type of request (TOR).....	230
<b>Appendix D</b>	<b>Whessoe device configuration.....</b>	<b>231</b>
D.1	Tank Database configuration for Whessoe devices.....	231
D.2	Advanced Whessoe configuration.....	234
<b>Appendix E</b>	<b>Modbus® standard question.....</b>	<b>237</b>



	E.1 Introduction.....	237
	E.2 FC02 status register area.....	238
	E.3 FC03 register area.....	240
	E.4 FC04 register area.....	242
	E.5 User defined Modbus server mapping.....	260
	E.6 User defined Modbus device mapping.....	263
<b>Appendix F</b>	<b>Fast polling.....</b>	<b>265</b>
	F.1 Overview.....	265
	F.2 Configure fast polling with common threshold.....	265
	F.3 Configure fast polling with individual thresholds.....	267
<b>Appendix G</b>	<b>L&amp;J device configuration.....</b>	<b>271</b>
	G.1 Tank Database configuration for L&J devices.....	271
	G.2 Advanced L&J configuration.....	272
<b>Appendix H</b>	<b>Varec® device configuration.....</b>	<b>275</b>
	H.1 Tank Database configuration for Varec® devices.....	275
	H.2 Advanced Varec configuration.....	277
<b>Appendix I</b>	<b>Enraf® 858 CIU configuration.....</b>	<b>279</b>
	I.1 Introduction.....	279
	I.2 Getting started.....	280
	I.3 Host port configuration.....	280
<b>Appendix J</b>	<b>TIC configuration.....</b>	<b>283</b>
	J.1 Tank Database configuration for TIC devices.....	283
	J.2 Advanced TIC device configuration.....	284
<b>Appendix K</b>	<b>Sakura configuration.....</b>	<b>285</b>
	K.1 Tank Database configuration for Sakura devices.....	285
	K.2 Advanced Sakura device configuration.....	288
<b>Appendix L</b>	<b>NRF590 configuration.....</b>	<b>291</b>
	L.1 Tank Database configuration for NRF590/4590 devices.....	291



# 1 Introduction

## 1.1 Safety messages

Instructions and procedures in this section may require special precautions to ensure the safety of the personnel performing the operations. Information that potentially raises safety issues is indicated by a warning symbol (⚠). Refer to the following safety messages before performing an operation preceded by this symbol.

### **⚠ WARNING**

**Failure to follow safe installation and servicing guidelines could result in death or serious injury.**

Ensure only qualified personnel perform the installation.

Use the equipment only as specified in this manual. Failure to do so may impair the protection provided by the equipment.

Ensure that the lid on the housing is closed during operation.

### **⚠ WARNING**

**Electrical shock could cause death or serious injury.**

Use extreme caution when making contact with the leads and terminals.

### **⚠ WARNING**

Any substitution of non-recognized parts may jeopardize safety. Repair (e.g. substitution of components) may also jeopardize safety and is not allowed under any circumstances.

### **⚠ WARNING**



#### **Physical access**

Unauthorized personnel may potentially cause significant damage to and/or misconfiguration of end users' equipment. This could be intentional or unintentional and needs to be protected against.

Physical security is an important part of any security program and fundamental in protecting your system. Restrict physical access by unauthorized personnel to protect end users' assets. This is true for all systems used within the facility.

## 1.2 Symbols

Table 1-1: Symbols

	The CE marking symbolizes the conformity of the product with the applicable European Community Directives.
	Protective Earth
	Ground

## 1.3 Manual overview

This manual provides information on installing, operating, and maintaining the Rosemount 2460. The sections are organized as follows:

Chapter [Overview](#) provides a brief description of the various components in a Rosemount Tank Gauging system and recommended installation procedure.

Chapter [Installation](#) covers installation considerations as well as mechanical and electrical installation.

Chapter [Configuration](#) describes how to configure the Rosemount 2460 System Hub by using the TankMaster WinSetup configuration program. This section includes inventory calculations and how to setup a pair of redundant system hubs.

Chapter [Operation](#) describes what information that is provided by the LEDs.

Chapter [Service and troubleshooting](#) covers tools, troubleshooting, and various service instructions.

Appendix [Specifications and reference data](#) contains specifications, dimensional drawings, and ordering table.

Appendix [Enraf® device configuration](#) describes how to configure the Rosemount 2460 tank database using the TankMaster WinSetup configuration program. It also covers how to configure fast polling and how to enable Vapor Temperature.

Appendix [Servo commands](#) describes various commands that can be used for tanks configured as servo tanks.

Appendix [Whessoe device configuration](#) describes how to configure the tank database of the Rosemount 2460 for Whessoe devices.

Appendix [Modbus® standard question](#) lists the database registers which can be scanned in queries from a Modbus master.

Appendix [Fast polling](#) describes how to enable and configure fast polling for varioius devices.

Appendix [L&J device configuration](#) describes how to configure the tank database of the Rosemount 2460 for L&J devices.

Appendix [Varec® device configuration](#) describes how to configure the tank database of the Rosemount 2460 for Varec devices.

Appendix [Enraf® 858 CIU configuration](#) describes how to configure the Rosemount 2460 for Enraf 858 CIU emulation.

Appendix [TIC configuration](#) describes how to configure the tank database of the Rosemount 2460 for TIC devices.

Appendix [Sakura configuration](#) describes how to configure the tank database of the Rosemount 2460 for Sakura devices.

Appendix [NRF590 configuration](#) describes how to configure the tank database of the Rosemount 2460 for NRF590 devices.

## 1.4 Technical documentation

The Rosemount Tank Gauging System includes a wide portfolio of user documentation. For a complete list, see product pages on [Emerson.com/Rosemount](https://www.emerson.com/Rosemount).

### Reference manuals

- Rosemount Tank Gauging System Configuration Manual (00809-0300-5100)
- Rosemount 2460 System Hub (00809-0100-2460)
- Rosemount 2410 Tank Hub (00809-0100-2410)
- Rosemount 5900S Radar Level Gauge (00809-0100-5900)
- Rosemount 5900C Radar Level Gauge (00809-0100-5901)
- Rosemount 2240S Multi-Input Temperature Transmitter (00809-0100-2240)
- Rosemount 2230 Graphical Field Display (00809-0100-2230)
- Rosemount 5300 Guided Wave Radar (00809-0100-4530)
- Rosemount 5408 Radar Level Transmitter (00809-0300-4408)
- Rosemount 3308 Series Wireless Guided Wave Radar (00809-0100-4308)
- Rosemount Tank Gauging Wireless System (00809-0100-5200)
- Rosemount TankMaster Software Installation Manual (00809-0400-5110)
- Rosemount TankMaster WinOpi (00809-0200-5110)
- Rosemount TankMaster WinSetup (00809-0100-5110)
- Rosemount TankMaster WinView (00809-0300-5110)
- Rosemount 5900 Proof Test with Reference Reflector (00809-0200-5900)
- Rosemount TankMaster Floating Roof Monitoring (00809-0500-5100)
- Rosemount TankMaster Full containment tanks (00809-0500-5110)
- Rosemount 5900 Radar Level Gauge and Rosemount 2410 Tank Hub Safety Manual Option S (00809-0400-5100)
- Rosemount 5900 Radar Level Gauge and Rosemount 2410 Tank Hub Safety Manual SIL3 (00809-0200-5100)
- Rosemount TankMaster Mobile User Guide (00809-0100-5120)
- Rosemount TankMaster Mobile Installation Manual (00809-0200-5120)

### Product data sheets

- Rosemount Tank Gauging System ([00813-0100-5100](#))
- Rosemount TankMaster Inventory Management Software ([00813-0100-5110](#))
- Rosemount TankMaster Mobile Inventory Management Software ([00813-0100-5120](#))
- Rosemount 2460 System Hub ([00813-0100-2460](#))
- Rosemount 2410 Tank Hub ([00813-0100-2410](#))
- Rosemount 5900S Radar Level Gauge ([00813-0100-5900](#))
- Rosemount 5900C Radar Level Gauge ([00813-0100-5901](#))
- Rosemount 2240S Multi-input Temperature Transmitter ([00813-0100-2240](#))
- Rosemount 565/566/765/614 Temperature and Water Level Sensors ([00813-0100-5565](#))
- Rosemount 2230 Graphical Field Display ([00813-0100-2230](#))
- Rosemount 5300 Level Transmitter ([00813-0100-4530](#))
- Rosemount 5408 Level Transmitter ([00813-0100-4408](#))

### Drawings

**Table 1-2: Installation Drawings for the Rosemount 2460 System Hub**

Drawing	Title
D7000001-927	Mechanical Installation Drawing Rosemount 2460 System Hub
D7000001-928	Electrical Installation Drawing Rosemount 2460 System Hub
D7000003-069	Electrical Installation Drawing redundant Rosemount 2460 system connection
D7000003-852	Electrical Installation Drawing Emulation

See web site on [Emerson.com/Rosemount](https://www.emerson.com/Rosemount) for latest issues.

Figure 1-1: System and User Documentation Structure

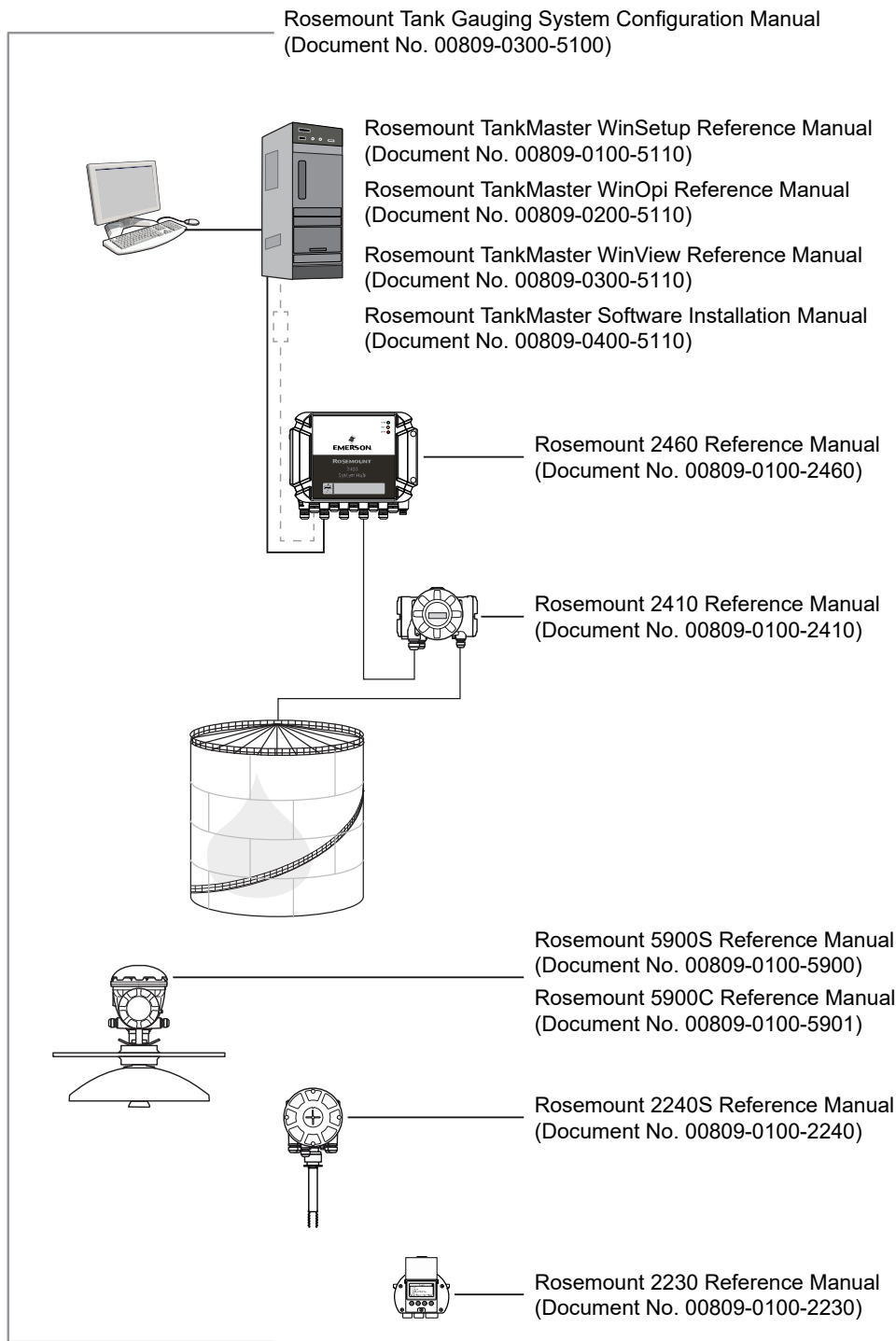



## 1.5 Product certifications

See the Rosemount 2460 [Product Certifications](#) document for detailed information on the existing approvals and certifications.

## 1.6 Service support

For service support contact the nearest Emerson Automation Solutions /Rosemount Tank Gauging representative. Contact information can be found on the web site [www.Emerson.com](http://www.Emerson.com).

## 1.7 Product recycling/disposal

Recycling of equipment and packaging should be taken into consideration and disposed of in accordance with local and national legislation/regulations.

## 1.8 Packing material

Rosemount Tank Radar AB is fully certified according to ISO 14001 environmental standards. By recycling the corrugated paperboard, or wooden boxes, used for shipping our products you can contribute to take care of the environment.

### Reuse and recycling

Experience has shown that wooden boxes can be used several times for various purposes. After careful disassembly the wooden parts may be reused. Metal waste may be converted.

### Energy recovery

Products which have served their time may be divided into wood and metal components and the wood can be used as fuel in sufficient ovens.

Due to its low moisture content (approximately 7%) this fuel has a higher calorific value than ordinary wood fuel (moisture content approximately 20%).

When burning interior plywood the nitrogen in the adhesives may increase emissions of nitrogen oxides to the air 3-4 times more than when burning bark and splinter.

---

### Note

Landfill is not a recycling option and should be avoided.

---



## 2 Overview

### 2.1 Introduction

In a typical Rosemount Tank Gauging system, a Rosemount 2460 System Hub collects measurement data and status information from various field devices. A standard installation includes a Rosemount 2460 connected to Rosemount 2410 Tank Hubs which collect measurement data and status information from the field devices.

Figure 2-1: System Integration

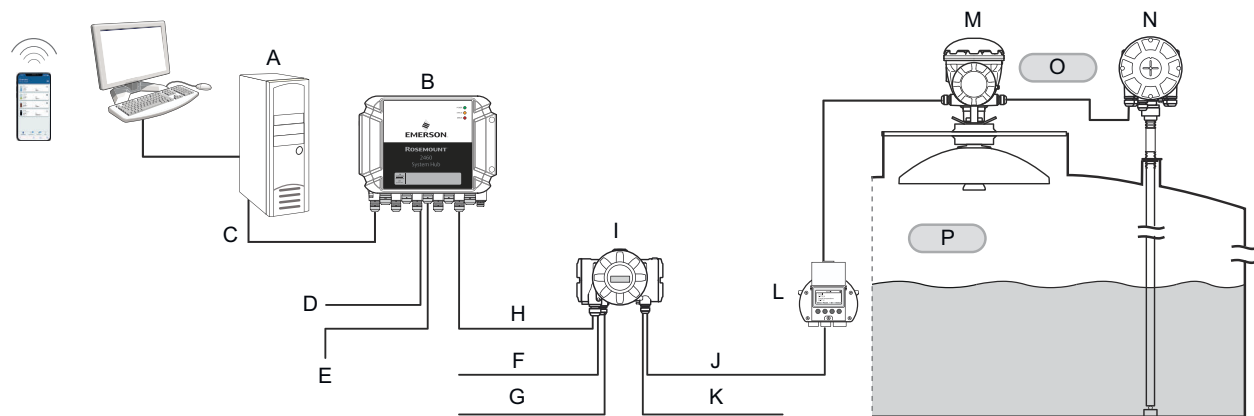

- |                              |  |
|------------------------------|--|
| A. Rosemount TankMaster      | I. Rosemount 2410 Tank Hub                 |
| B. Rosemount 2460 System Hub | J. Tankbus                                 |
| C. Ethernet (Modbus TCP)     | K. Secondary bus (IS)                      |
| D. Host                      | L. Rosemount 2230 Field Display            |
| E. Servo gauges              | M. Rosemount 5900S Radar Level Gauge       |
| F. Secondary Bus (Non-IS)    | N. Rosemount 2240S Temperature Transmitter |
| G. Relay Outputs             | O. Zone 1                                  |
| H. Primary Bus               | P. Zone 0                                  |

A Rosemount 2460 buffers measurement data and status information from one or more tanks, and sends the information to a TankMaster PC, or other host system, whenever the Rosemount 2460 receives a request for data.

## 2.2 Communication

The Rosemount Tank Gauging system supports various communication interfaces for field devices, TankMaster PC and other host computers.

**Figure 2-2: Typical Configuration of a Rosemount 2460 System Hub**

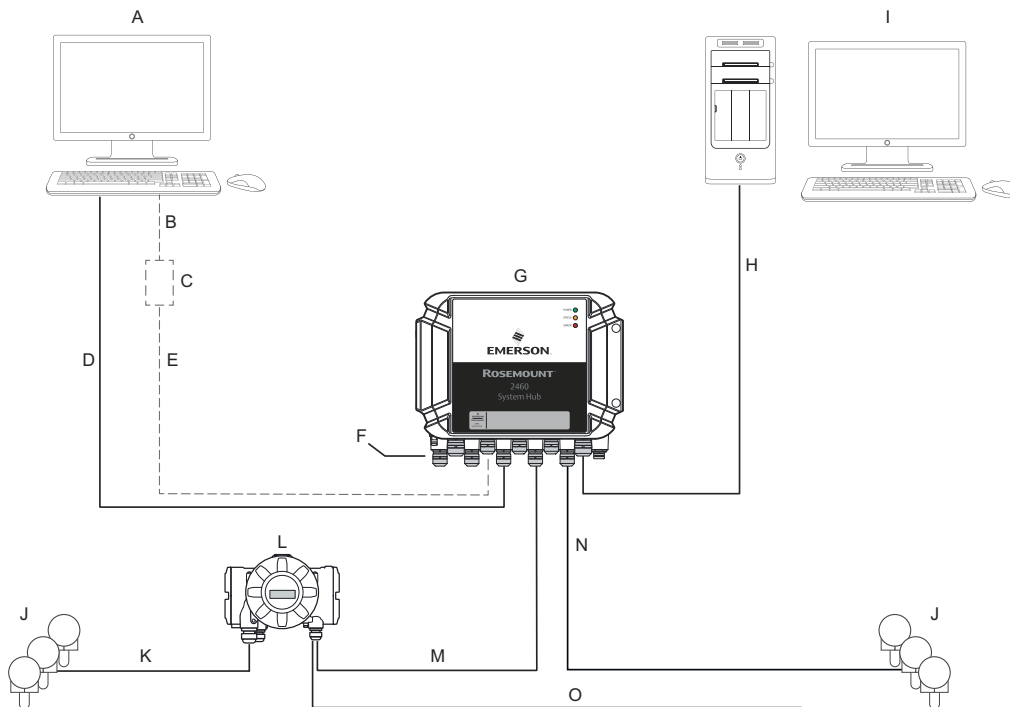

- A. TankMaster™
- B. USB, RS232
- C. Modem
- D. Ethernet (Modbus® TCP), RS232, RS485
- E. TRL2, RS485
- F. Host and Field ports
- G. Rosemount 2460 System Hub
- H. Ethernet (Modbus® TCP), TRL2, RS232, RS485
- I. Other hosts
- J. Field devices
- K. Tankbus
- L. Rosemount 2410 Tank Hub
- M. Primary bus: TRL2, RS485
- N. TRL2, RS485, other vendors
- O. Secondary bus: Enraf®, Whessoe and others, HART® 4-20 mA analog output/input

The Rosemount 2460 System Hub collects measurement data from field devices and transmits the data to a host system. It also handles communication from a host to the field devices.

The Rosemount 2460 supports a number of host communication interface standards such as Ethernet, TRL2, RS485, and RS232. TRL2 and RS485 are supported for field device

communication also, as well as other standards such as Enraf and Digital Current Loop (Whessoe).

The Rosemount 2410 Tank Hub has a Primary bus and a Secondary bus that can be used for TRL2 Modbus (standard) or RS485 Modbus communication<sup>(1)</sup>. The Secondary bus supports other communication protocols as well, such as Enraf, Varec etc.

---

(1) See [Cabling for the TRL2/RS485 Bus](#) for information on cable requirements.

## 2.3 Components

This section shows the various parts of the Rosemount 2460 System Hub.

### Note

The Rosemount 2460 is designed for use in non-hazardous areas.

**Figure 2-3: Rosemount 2460 System Hub Front and Top View**

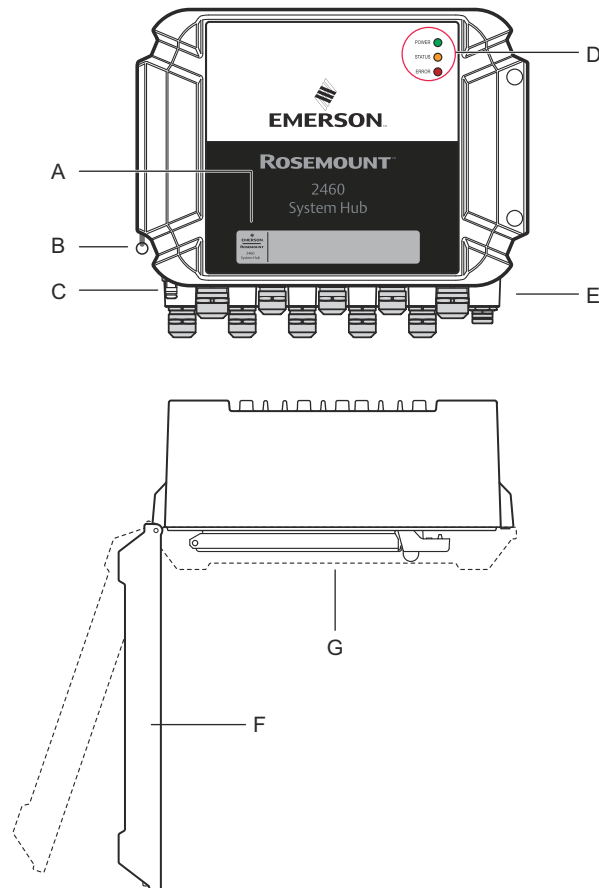

- A. Main label
- B. Locking ring for securing lid
- C. External ground terminal (M5 screw, flat, lug dimension max. 10 x 4 mm)
- D. LEDs for status and error messages
- E. Cable entries (Nine (9) M20 x 1.5, Two (2) M25 x 1.5)
- F. Lid (can be removed by removing the locking ring)
- G. Terminal compartment with communication boards and ports

**Figure 2-4: Cable Entries**

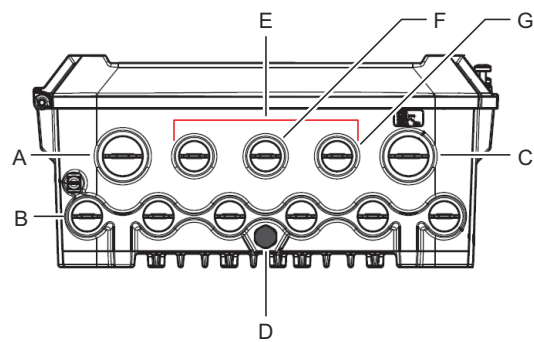

- A. Cable entry M25
- B. Cable entries (6 x M20 x 1.5)
- C. Cable entry M25 (power)
- D. Membrane
- E. Cable entries (3 x M20 x 1.5)
- F. Cable entry for Ethernet connection ETH 1
- G. Cable entry for Ethernet connection ETH 2

Figure 2-5: Inside the Rosemount 2460 System Hub

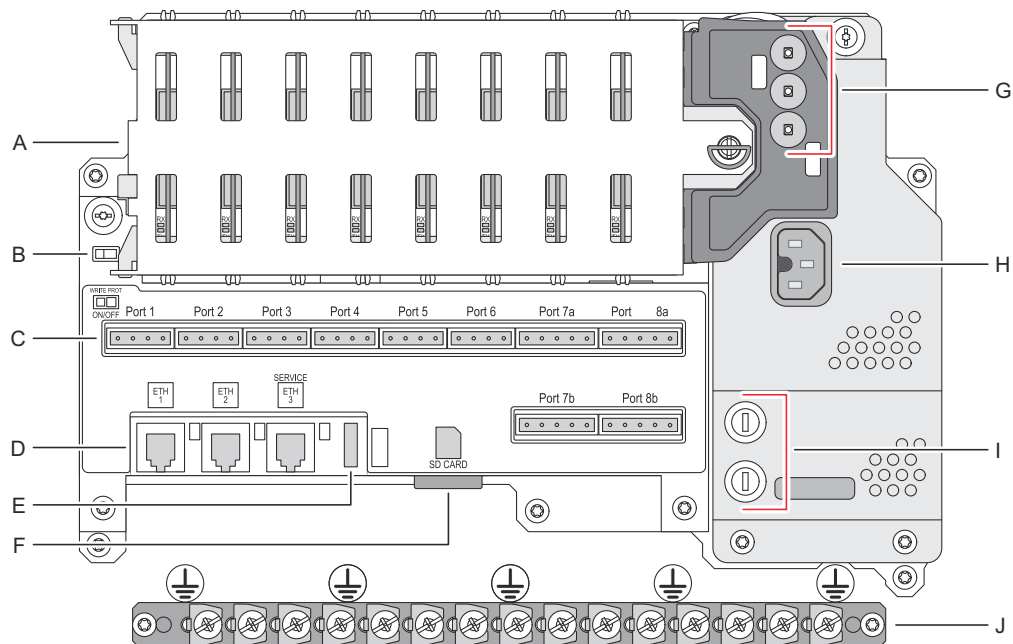

- A. Communication boards
- B. Write protection switch
- C. Terminal board / ports (1 to 8)
- D. Ethernet ports
- E. USB port
- F. SD memory card slot
- G. LEDs (power=green, status=yellow, error=red)
- H. Power input connector (IEC C16)
- I. Fuses
- J. Ground bar

**Note**

For signal/shield wire ground only.



### 2.3.1 Enclosure

The Rosemount 2460 System Hub is designed with a weather protected, wall-mounted box.

**Figure 2-6: Enclosure**



### 2.3.2 Write protection switch

The Rosemount 2460 System Hub is equipped with a write protection switch for preventing unauthorized changes of the 2460 configuration database.

**Figure 2-7: Write protection**

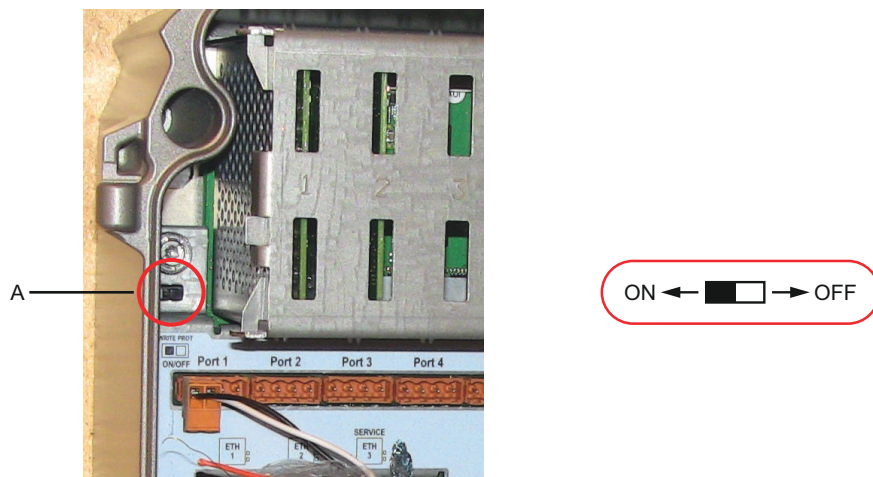

*A. Write protection switch*

In addition to the switch, the Rosemount 2460 supports software write protection.

#### **Related information**

[Software write protection](#)

## 2.4 System overview

The Rosemount Tank Gauging system is a state-of-the art inventory and custody transfer radar tank level gauging system. It is developed for a wide range of applications at refineries, tank farms and fuel depots, and fulfills the highest requirements on performance and safety.

The field devices on the tank communicate over the intrinsically safe Tankbus. The Tankbus is based on a standardized fieldbus, the FISCO<sup>(2)</sup> FOUNDATION™ Fieldbus, and allows integration of any device supporting that protocol. By utilizing a bus powered 2-wire intrinsically safe fieldbus the power consumption is minimized. The standardized fieldbus also enables integration of other vendors' equipment on the tank.

The Rosemount Tank Gauging product portfolio includes a wide range of components to build small or large customized tank gauging systems. The system includes various devices, such as radar level gauges, temperature transmitters, and pressure transmitters for complete inventory control. Such systems are easily expanded thanks to the modular design.

The Rosemount Tank Gauging system is a versatile system that is compatible with and can emulate all major tank gauging systems. Moreover, the well-proven emulation capability enables step-by-step modernization of a tank farm, from level gauges to control room solutions.

It is possible to replace old mechanical or servo gauges with modern Rosemount Tank Gauging devices, without replacing the control system or field cabling. It is further possible to replace old HMI/SCADA-systems and field communication devices without replacing the old gauges.

There is a distributed intelligence in the various system units which continuously collect and process measurement data and status information. When a request for information is received an immediate response is sent with updated information.

The flexible Rosemount Tank Gauging system supports several combinations to achieve redundancy, from control room to the different field devices. Redundant network configuration can be achieved at all levels by doubling each unit and using multiple control room work stations.

---

<sup>(2)</sup> See documents IEC 61158-2

Figure 2-8: Rosemount Tank Gauging System Architecture

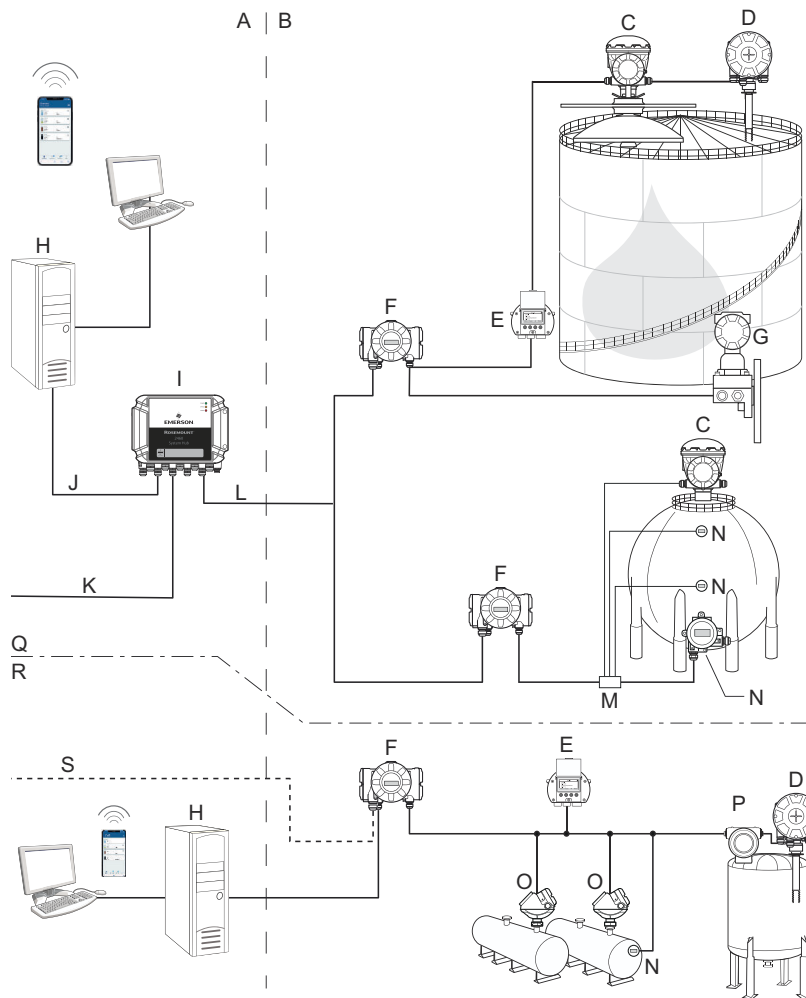

- |  |  |
|--|--|
| A. Non-hazardous area                      | K. Plant Host Computer                       |
| B. Hazardous area                          | L. TRL2 Modbus                               |
| C. Rosemount 5900S Radar Level Gauge       | M. Segment coupler                           |
| D. Rosemount 2240S Temperature Transmitter | N. Rosemount 644 Temperature Transmitter     |
| E. Rosemount 2230 Graphical Field Display  | O. Rosemount 5300 Level Transmitter          |
| F. Rosemount 2410 Tank Hub                 | P. Rosemount 5408 Level Transmitter          |
| G. Rosemount 3051S Pressure Transmitter    | Q. Custody transfer / Inventory tank gauging |
| H. Rosemount TankMaster PC                 | R. Operational control                       |
| I. Rosemount 2460 System Hub               | S. Plant host computer                       |
| J. Ethernet (Modbus TCP)                   |  |

Figure 2-9: Rosemount Tank Gauging System Architecture for Wireless Systems

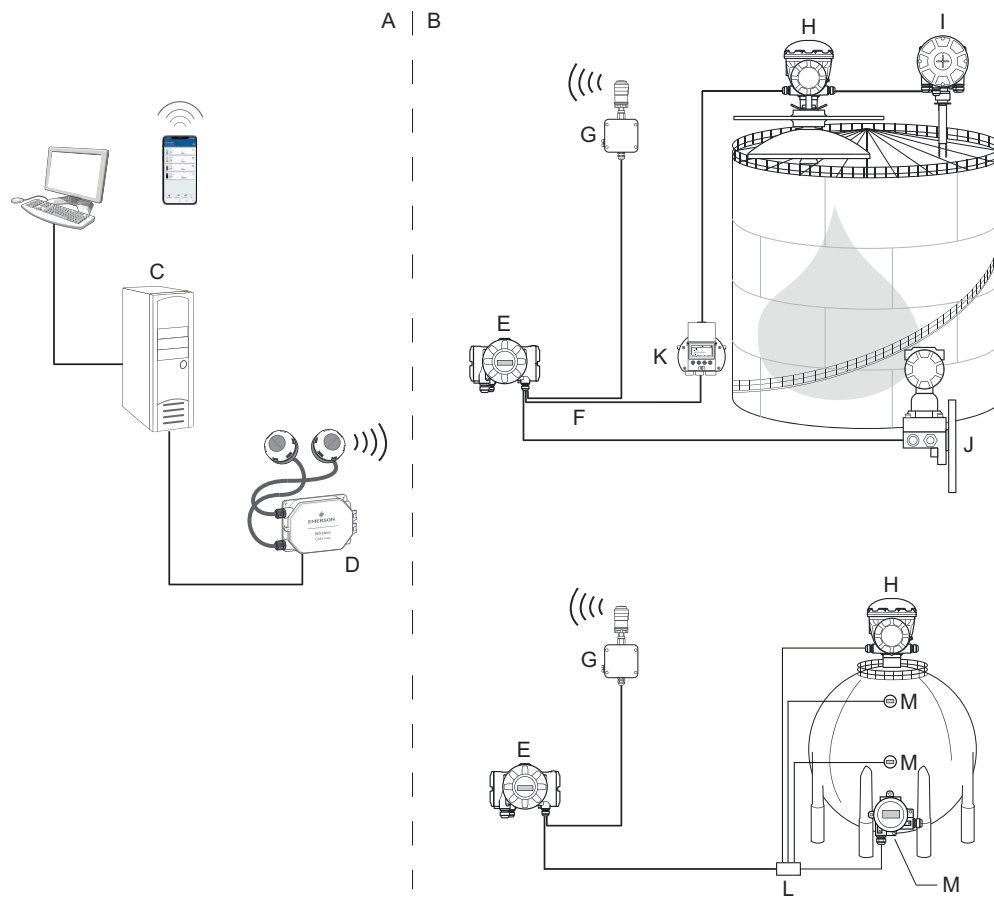

- A. Non-hazardous area
- B. Hazardous area
- C. Rosemount TankMaster PC
- D. Emerson Wireless Gateway
- E. Rosemount 2410 Tank Hub
- F. Tankbus
- G. Emerson Wireless 775 THUM Adapter
- H. Rosemount 5900S Radar Level Gauge
- I. Rosemount 2240S Temperature Transmitter
- J. Rosemount 3051S Pressure Transmitter
- K. Rosemount 2230 Graphical Field Display
- L. Segment coupler
- M. Rosemount 644 Temperature Transmitter

Figure 2-10: Rosemount Tank Gauging System Architecture in a FOUNDATION Fieldbus Network

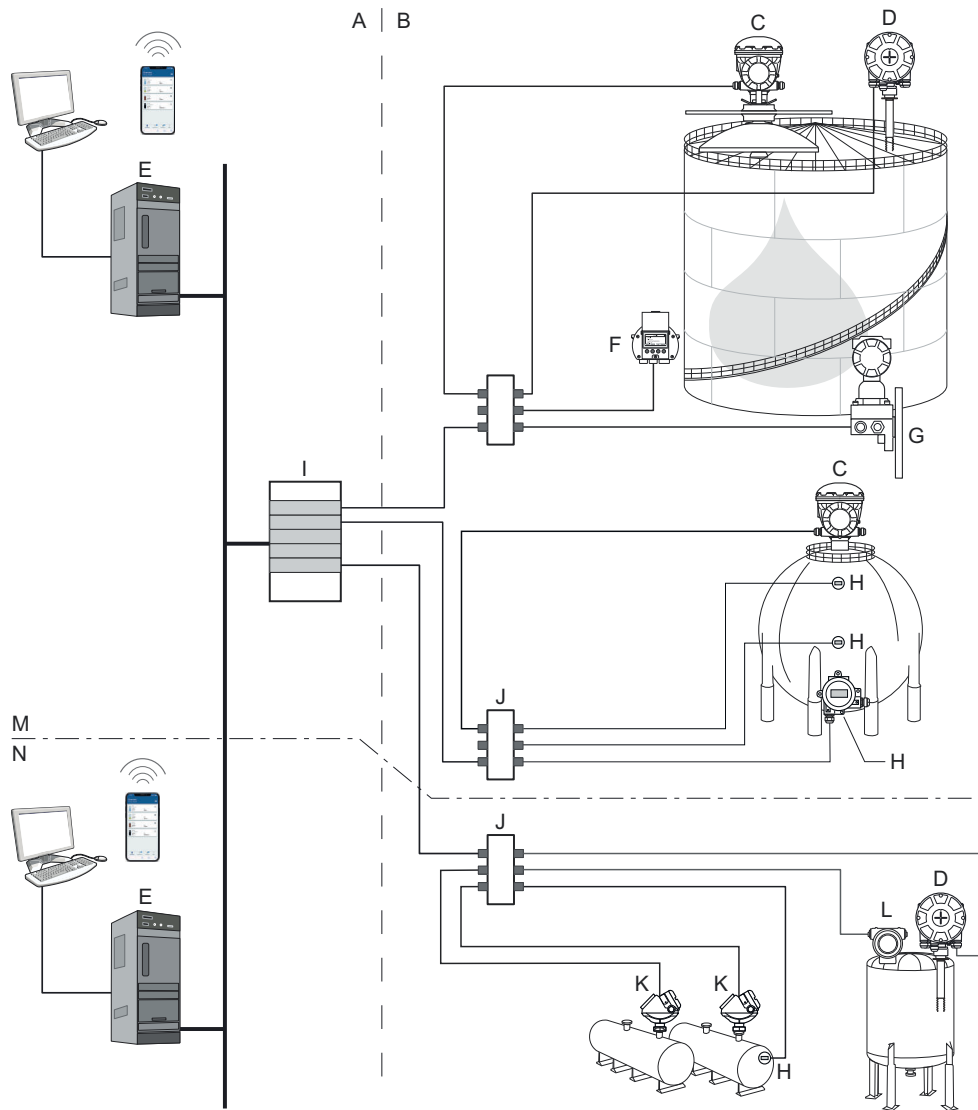

- |    |   |    |   |
|----|---|----|---|
| A. | Non-hazardous area                      | H. | Rosemount 644 Temperature Transmitter     |
| B. | Hazardous area                          | I. | FOUNDATION Fieldbus Power Supply          |
| C. | Rosemount 5900S Radar Level Gauge       | J. | Segment coupler                           |
| D. | Rosemount 2240S Temperature Transmitter | K. | Rosemount 5300 Level Transmitter          |
| E. | PC                                      | L. | Rosemount 5408 Level Transmitter          |
| F. | Rosemount 2230 Graphical Field Display  | M. | Custody transfer / Inventory tank gauging |
| G. | Rosemount 3051S Pressure Transmitter    | N. | Operational control                       |

## 2.4.1 TankMaster HMI software

Rosemount TankMaster is a powerful Windows-based Human Machine Interface (HMI) for complete tank inventory management. It provides configuration, service, set-up, inventory, and custody transfer functions for Rosemount Tank Gauging systems and other supported instruments.

Rosemount TankMaster is designed to be used in the Microsoft® Windows environment providing easy access to measurement data from your Local Area Network (LAN).

The Rosemount TankMaster WinOpi program lets the operator monitor measured tank data. It includes alarm handling, batch reports, automatic report handling, historical data sampling as well as inventory calculations such as Volume, Observed Density and other parameters. A plant host computer can be connected for further processing of data.

The Rosemount TankMaster WinSetup program is a graphical user interface for installation, configuration and service of devices in the Rosemount Tank Gauging system.

## 2.4.2 Rosemount 2460 System Hub

The Rosemount 2460 System Hub is a data concentrator that continuously polls and stores data from field devices such as radar level gauges and temperature transmitters in a buffer memory. Whenever a request for data is received, the system hub can immediately send data from the updated buffer memory for a group of tanks.

Measured and calculated data from one or more tanks is communicated via the Rosemount 2410 Tank Hub to the system hub buffer memory. Whenever a request is received, the system hub can immediately send data from a group of tanks to a TankMaster PC, or a host.

The Rosemount 2460 can be used to connect devices from other vendors as well, such as Honeywell® Enraf and Whessoe.

The Rosemount 2460 has eight slots for communication interface boards. These boards can be individually configured for communication with hosts or field devices. They can be ordered either for TRL2, RS485, Enraf BPM or Whessoe 0-20 mA/RS485 communication. Two slots can also be configured for RS232 communication.

One of the system hub's three Ethernet ports is used for Modbus TCP connection to host systems. By simply connecting the system hub to the existing LAN network, communication over Ethernet is established.

The system hub can provide redundancy for critical operations, by using two identical devices. The primary system hub is active and the other one is in passive mode. If the primary unit stops working properly, the secondary unit is activated and a failure message is sent to TankMaster (or a DCS system).

## 2.4.3 Rosemount 2410 Tank Hub

The Rosemount 2410 Tank Hub acts as a power supply to the connected field devices in the hazardous area using the intrinsically safe Tankbus.

The tank hub collects measurement data and status information from field devices on a tank. It has two external buses for communication with various host systems.

The Rosemount 2410 is available in three versions:

- single tank
- multiple tanks
- functional safety/SIS applications (SIL 2 single tank)

The multiple tanks version of the Rosemount 2410 supports up to 10 tanks and 16 devices. With the Rosemount 5300 the Rosemount 2410 supports up to 5 tanks.

The Rosemount 2410 is equipped with two relays which support configuration of up to 10 “virtual” relay functions allowing you to specify several source signals for each relay.

The Rosemount 2410 supports Intrinsically Safe (IS) and Non-Intrinsically Safe (Non-IS) analog 4-20 mA inputs/outputs. By connecting an Emerson Wireless 775 THUM Adapter to the IS HART 4-20 mA output, the tank hub is capable of wireless communication with an Emerson Wireless Gateway in a *WirelessHART*<sup>®</sup> network.

## 2.4.4 Rosemount 5900S Radar Level Gauge

The Rosemount 5900S Radar Level Gauge is an intelligent instrument for measuring the product level inside a tank. Different antennas can be used in order to meet the requirements of different applications. The Rosemount 5900S can measure the level of almost any product, including bitumen, crude oil, refined products, aggressive chemicals, LPG and LNG.

The Rosemount 5900S sends microwaves towards the surface of the product in the tank. The level is calculated based on the echo from the surface. No part of the Rosemount 5900S is in actual contact with the product in the tank, and the antenna is the only part of the gauge that is exposed to the tank atmosphere.

The 2-in-1 version of the Rosemount 5900S Radar Level Gauge has two radar modules in the same transmitter housing allowing two independent level measurements using one antenna and one tank opening.

## 2.4.5 Rosemount 5300 Guided Wave Radar

The Rosemount 5300 is a premium 2-wire guided wave radar for level measurements on liquids, to be used in a wide range of medium accuracy applications under various tank conditions. Rosemount 5300 includes the Rosemount 5301 for liquid level measurements and the Rosemount 5302 for liquid level and interface measurements.

## 2.4.6 Rosemount 5408 Radar Level Transmitter

The Rosemount 5408 is a non-contacting level transmitter for accurate and reliable level measurement on small storage and buffer tanks.

The Rosemount 5408 provides accurate and reliable level measurements for metallic and non-metallic vessels. It is suitable for almost any liquid and is ideal for challenging applications with agitators, foam, high temperatures, and pressures. It is also an excellent choice for level measurement in tanks with small diameter (2- to 4-inch) stilling wells.

The narrow beam makes the Rosemount 5408 the ideal solution for bulk solids in small to medium sized silos with rapid level changes.

For safety functions such as overflow prevention, level deviation monitoring, or dry-run prevention, the Rosemount 5408:SIS is the ideal choice.

## 2.4.7 Rosemount 2240S Multi-Input Temperature Transmitter

The Rosemount 2240S Multi-input Temperature Transmitter can connect up to 16 temperature spot sensors and an integrated water level sensor.

## 2.4.8 Rosemount 2230 Graphical Field Display

The Rosemount 2230 Graphical Field Display presents inventory tank gauging data such as level, temperature, and pressure. The four softkeys allow you to navigate through the different menus to provide all tank data, directly in the field. The Rosemount 2230 supports up to 10 tanks. Up to three Rosemount 2230 displays can be used on a single tank.

## 2.4.9 Rosemount 644 Temperature Transmitter

The Rosemount 644 is used with single spot temperature sensors.

## 2.4.10 Rosemount 3051S Pressure Transmitter

The Rosemount 3051S series consists of transmitters and flanges suitable for all kinds of applications, including crude oil tanks, pressurized tanks and tanks with / without floating roofs.

By using a Rosemount 3051S Pressure Transmitter near the bottom of the tank as a complement to a Rosemount 2460 Radar Level Gauge, the density of the product can be calculated and presented. One or more pressure transmitters with different scalings can be used on the same tank to measure vapor and liquid pressure.

## 2.4.11 Rosemount 2180 Field Bus Modem

The Rosemount 2180 Field Bus Modem (FBM) is used for connecting a TankMaster PC to the TRL2 communication bus. The Rosemount 2180 is connected to the PC using either the USB or the RS232 interface.

## 2.4.12 Emerson Wireless Gateway and Emerson Wireless 775 THUM™ Adapter

An Emerson Wireless THUM Adapter allows wireless communication between a Rosemount 2410 Tank Hub and an Emerson Wireless Gateway. The gateway is the network manager that provides an interface between field devices and the Rosemount TankMaster inventory software or host/DCS systems.

See the Rosemount Tank Gauging [System Data Sheet](#) for more information on the various devices and options.

## 2.5 Installation procedure

Follow these steps for a proper installation:

### Procedure

1. Review installation considerations.  
See [Installation considerations](#).
2. Optional: If needed, install modem cards to support the desired communication protocols.  
See [Exchanging a modem card](#).
3. Mount the Rosemount 2460 System Hub.  
See [Mechanical installation](#).



4. Wire the Rosemount 2460.  
See [Electrical installation](#).
5. Ensure covers and cable gland/conduit connections are tight.
6. Power up the Rosemount 2460.
7. Configure the Rosemount 2460.  
See [Configuration](#).
  - a) Enable communication with host system.
  - b) Configure ports.
  - c) Configure Tank Database Verify operation.
8. Optional: Enable the Write Protection switch if required.



## 3 Installation

### 3.1 Section overview

This section covers installation considerations and instructions for mechanical and electrical installation.

### 3.2 Safety messages

Instructions and procedures in this section may require special precautions to ensure the safety of the personnel performing the operations. Information that potentially raises safety issues is indicated by a warning symbol (⚠). Refer to the following safety messages before performing an operation preceded by this symbol.

#### **⚠ WARNING**

**Failure to follow safe installation and servicing guidelines could result in death or serious injury.**

Ensure only qualified personnel perform the installation.

Use the equipment only as specified in this manual. Failure to do so may impair the protection provided by the equipment.

Do not perform any service other than those contained in this manual unless you are qualified.

#### **⚠ WARNING**

**High voltage that may be present on leads could cause electrical shock.**

Avoid contact with leads and terminals.

Ensure the main power to the Rosemount 2460 System Hub is off and the lines to any other external power source are disconnected or not powered while wiring the 2460.

#### **⚠ WARNING**

**Electrical shock could cause death or serious injury.**

Use extreme caution when making contact with the leads and terminals.

#### **⚠ CAUTION**

Ensure that there is no water or snow on top of the lid when it is opened. This may damage the electronics inside the housing.

### **⚠ CAUTION**

Be careful when opening the lid in very low temperatures. High humidity and temperatures far below the freezing point may cause the gasket to get stuck to the lid. In that case you may use a heating fan to warm the housing in order to release the gasket. Be careful not to use excess heat which may damage the housing and electronics.

## **3.3 Installation considerations**

The Rosemount 2460 System Hub may be installed on various non-hazardous locations at the plant.

- In case the system hub is exposed to long periods of sunshine, a sunshade should be used to prevent the system hub from being heated to temperatures above the maximum operating temperature. Sunshade is to be manufactured and designed locally to suit the installation.
- Ensure that environmental conditions are within specified limits.
- Ensure that the system hub is installed such that it is not exposed to higher pressure and temperature than specified.
- Do not install the system hub in non-intended applications, for example environments where it may be exposed to extremely intense magnetic fields or extreme weather conditions.
- Use an external circuit breaker in order to ensure that power supply can be safely disconnected when wiring and servicing the system hub. The circuit breaker shall be easily accessible and appropriately labeled.
- In case devices from other vendors will be connected to the system hub, ensure that correct modem cards are installed for the field ports that will be used.
- Ensure that correct firmware version is used that supports the desired communication options and features.

In case Rosemount TankMaster is used for configuration of the system hub consider the following:

- Ensure that TankMaster version 6.B6 or higher is used for Rosemount 2460 configuration.
- TankMaster 6.C0 and higher is required for configuration of Enraf communication on field ports.
- TankMaster 6.D0 and higher is required for configuration of redundant system hubs.
- TankMaster 6.G0 and higher is required for using redundant field ports.

### **Important**

Check the system hub for any signs of damage prior to installation.

Ensure that O-rings and gaskets are in good condition.

Check that all modems are firmly mounted in their slots and cannot move.

### 3.3.1 Installation planning

It's recommended to plan the installation in order to ensure that all components in the system are properly specified. The planning stage should include the following tasks:

- Make a plan of the site and specify suitable locations for the devices
- Consider power budget
- Specify cabling and connections (for example whether devices will be "daisy-chained" or not)
- Specify cable glands that will be needed for the various devices
- Specify location of terminators on the Tankbus (Rosemount 2410 Tank Hub)
- Make a note of identification codes such as Unit ID/Device ID of each device
- Assign communication addresses for level gauges and other tank devices to be stored in the Tank Databases<sup>(3)</sup> of the Rosemount 2460 System Hub and Rosemount 2410 Tank Hub

---

<sup>(3)</sup> See the Rosemount Tank Gauging [System Configuration Manual](#) (Document no. 00809-0300-5100) and the Rosemount 2410 Tank Hub [Reference Manual](#) (Document no. 00809-0100-2410) for more information.

## 3.4 Mechanical installation

The housing of the Rosemount 2460 is designed with four holes for attaching it to a wall using four screws. See also Mechanical Installation Drawing D7000001-927 for further information.

### Prerequisites

---

#### Note

Ensure that the Rosemount 2460 is installed in a way that minimizes vibration and mechanical shock.

---

### Procedure

1. Mark the positions of the four screws to be used for attaching the system hub to the wall. A mounting template (see [Figure 3-1](#)) is shipped with the system hub which may be used for this purpose.
2. Drill four holes with appropriate size to fit screw diameter 6 mm.
3. Loosen the two screws (M6 x 2) that keep the lid in closed position and open the lid.

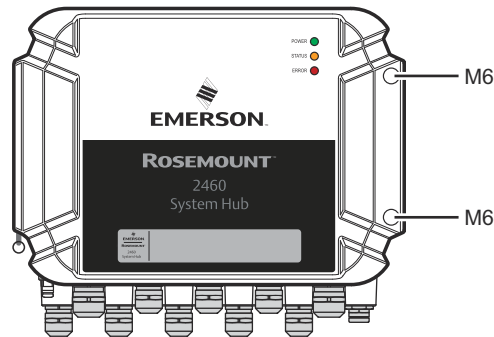

4. Attach the system hub to the wall. There are four holes on the housing to be used for the screws.

The required screw dimension is given by [Figure 3-2](#).

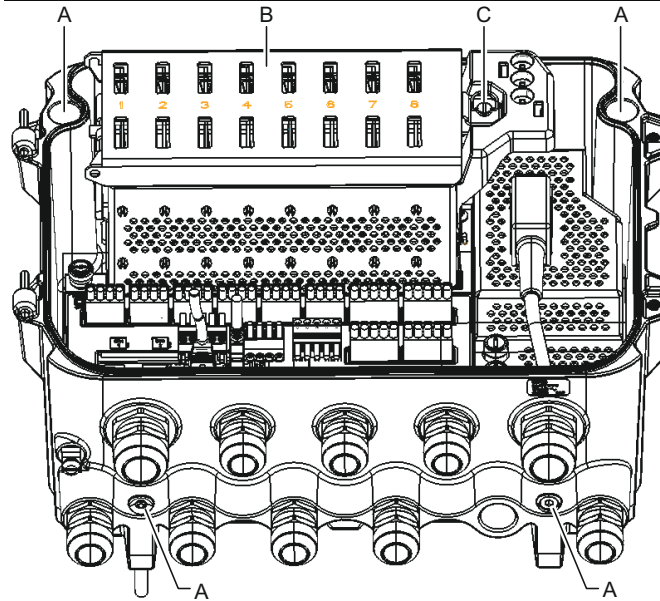

- A. Holes (x4) for attaching the system hub to a wall
- B. Communication board compartment
- C. Lock ring

5. ⚠ Ensure that the Lock ring (C) on the cover to the communication board compartment is folded so that it does not prevent the lid from being properly closed. Close the lid and ensure that it is fully engaged to prevent water from entering the terminal compartment. Torque the two screws to 4 Nm (35 in.-lb).

### 3.4.1 Mounting template

A mounting template is shipped with the Rosemount 2460 which can be used to mark the position of the holes (see [Figure 3-1](#)).

**Figure 3-1: Mounting Template with Hole Pattern for the Rosemount 2460 System Hub**

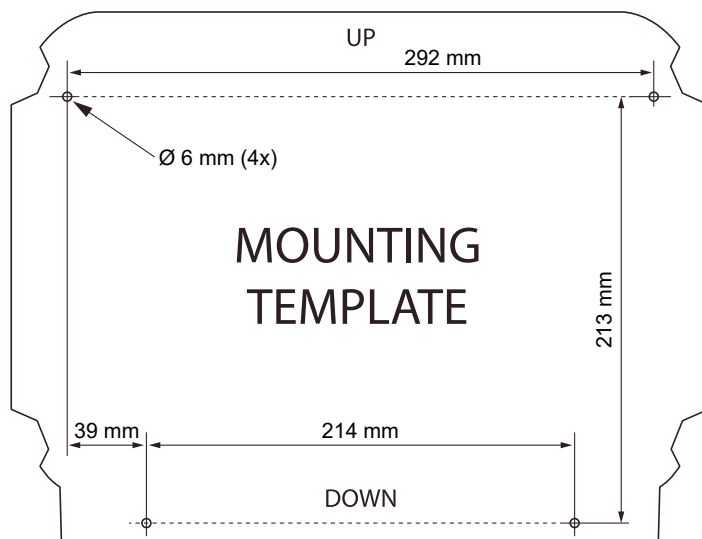

Ensure that the four screws meet the specifications given in [Figure 3-2](#).

**Figure 3-2: Rosemount 2460 System Hub Dimensions**

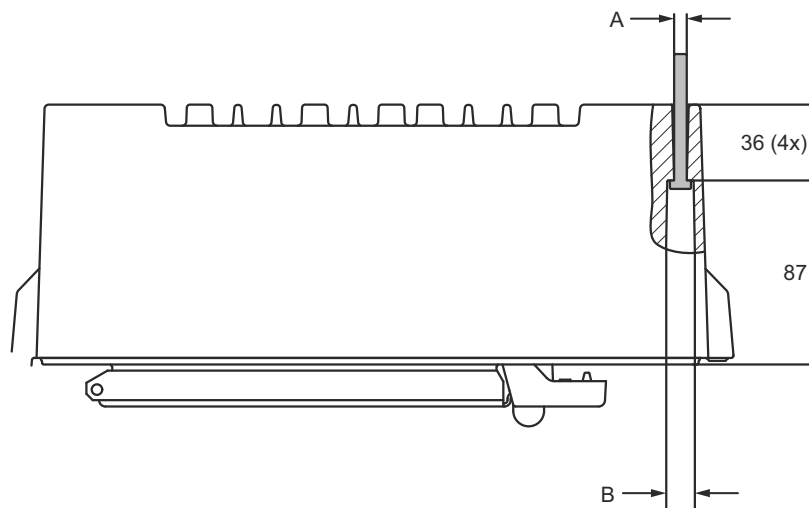

- A. Four holes Ø 6.5 mm
- B. Ø 12.5 mm (4x); Maximum dimension of screw head

Dimensions are in mm.



## 3.5 Electrical installation

### 3.5.1 Electrical installation drawing

See Electrical Installation Drawing D7000001-928 for further information.

### 3.5.2 Cable entries

The Rosemount 2460 housing has nine M20 x 1.5 and two M25 x 1.5 entries. Connections must be made in accordance with local or plant electrical codes.

Make sure that unused cable entries are properly sealed to prevent moisture or other contamination from entering the terminal board compartment of the electronics housing.

#### NOTICE

Thread sealing (PTFE) tape or paste on male threads of conduit is required to provide a water/dust tight conduit seal and to meet the required degree of ingress protection as well as to enable future removal of the plug/gland.

Use the enclosed metal plugs to seal unused cable entries in order to achieve required level of ingress protection. The plastic plugs mounted at delivery are not sufficient as seal.

### 3.5.3 Power supply

The Rosemount 2460 System Hub accepts supply voltage 100 - 250 Vac (50/60 Hz) and 24 - 48 Vdc.

#### Note

The Rosemount 2460 is polarity insensitive for DC voltage input.

### 3.5.4 Cable selection for power supply

Appropriate cross sectional area of wires must be used in order to prevent a high voltage drop to the connected device. Recommended cable size is 0.75 mm<sup>2</sup> to 2.1 mm<sup>2</sup> (18 AWG to 14 AWG) in order to minimize the voltage drop.

### 3.5.5 Grounding

The housing should always be grounded in accordance with national and local electrical codes. Failure to do so may impair the protection provided by the equipment. The most effective grounding method is direct connection to earth ground with minimal impedance.

There is a grounding screw on the housing which is identified by ground symbol  $\perp$ .

Inside the Rosemount 2460's terminal compartment there is a ground bar with screw connections identified by ground symbols  $\oplus$ . The ground bar shall only be used for connecting signal related ground wires, e.g. shield ground connections from the field bus harness. The protective earth ground connection shall be connected to the system hub via the dedicated power board IEC plug and the external grounding screw on the housing.

Connect shield to ground at one end only, otherwise a ground loop may occur.

**NOTICE**

Grounding the device via threaded conduit connection may not provide sufficient ground.

**Related information**

[Components](#)

### 3.5.6 Cabling for the TRL2/RS485 Bus

In a Rosemount Tank Gauging system a Rosemount 2460 System Hub communicates with a TankMaster control room PC using the TRL2/RS485 Modbus® protocol.

**TRL2 Bus**

The TRL2 bus requires twisted and shielded pair wiring with a minimum cross-sectional area of 0.50 mm<sup>2</sup> (AWG 20 or similar). The maximum length of the TRL2 bus is approximately 4 km /13000 ft. The TRL2 field bus can normally use existing cables in the tank area.

Cable cross-sectional area for the TRL2 wiring should follow the recommendations in [Table 3-1](#).

**Table 3-1: Minimum Cable Area for the TRL2 Bus**

Maximum distance	Cross-sectional area	
	Minimum	Maximum
3 km	0.50 mm <sup>2</sup> (AWG 20)	2.5 mm <sup>2</sup>
4 km	0.75 mm <sup>2</sup> (AWG 18)	2.5 mm <sup>2</sup>

**Note**

Wherever two or more TRL2 buses run alongside each other, sharing the same cable or conduit tube, use twisted and shielded wire and ensure that each pair of bus wires is individually shielded in order to avoid crosstalk.

**Figure 3-3: Individually Shielded Pair Cables Minimizes Crosstalk**

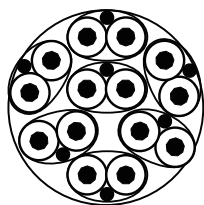

[Table 3-2](#) shows typical cable types that can be used for connecting the TRL2 bus. Other cables of similar type may also be used.

**Table 3-2: Recommended Cable Standards for the TRL2 Bus**

Type	Manufacturing standard	Core size
Signal	BS 5308 part 1, type 1	1 mm <sup>2</sup>
Signal (armoured)	BS 5308 part 2, type 1	1 mm <sup>2</sup>

**RS485 Bus**

The RS485 bus should meet the following requirements:

- twisted and shielded pair wiring
- characteristic impedance of 120  $\Omega$
- maximum cable length 1200 m / 4000 ft at baud rate 9600 bps

### 3.5.7 Connecting to a Rosemount 2460 System Hub

There are several ways to connect a Rosemount 2460 System Hub to a host system:

- from a Host Port using TRL2 bus
- from a Host Port using RS232 or RS485
- via Ethernet Eth1 port

The TRL2 Bus requires a twisted and shielded pair cable with a cross-sectional area of 0.50 to 2.5 mm<sup>2</sup> (20 to 14 AWG). A Rosemount 2180 Field Bus Modem (FBM) is used to connect the system hub to TankMaster or other host computer.

A service PC can be connected to the Ethernet Eth3 port for configuration and maintenance.

For RS232 communication, wiring cross-sectional area must be at least 0.25 mm<sup>2</sup> (24 AWG or similar). The typical maximum length of the RS232 connection is 30 m at baud rate 4800.

**Table 3-3: Data Rate and Maximum Distances for RS232 Communication**

Baud rate (bps)	Distance (m)
2400	60
4800	30
9600	15
19200	7.6

#### Related information

[Terminal board and ports](#)

### Communication ports for hosts and field devices

The Rosemount 2460 System Hub has eight ports for communication interface boards. It is equipped with interface boards for field device communication and host communication. The specific configuration is specified in the ordering information. Communication boards can easily be exchanged if needed.

Port 8 is used for TankMaster communication. Port 7 is used for host or TankMaster communication as specified in the ordering information.

Port 1 to Port 4 are used for field device communication.

Ports 5 and 6 can be used for host or field device communication as specified in the ordering information. This allows you to vary the number of field and host ports depending on the specific requirements.

[Table 3-4](#) shows various configuration options for a system hub.

**Table 3-4: Port Configuration Options**

Ports	1	2	3	4	5	6	7	8
Alternative 6+2 (standard)	Field Port	Field Port	Field Port	Field Port	Field Port	Field Port	Host Port	Host Port
Alternative 5+3	Field Port	Field Port	Field Port	Field Port	Field Port	Host Port	Host Port	Host Port
Alternative 4+4	Field Port	Field Port	Field Port	Field Port	Host Port	Host Port	Host Port	Host Port

**Related information**

[Communication/configuration specifications](#)  
[Exchanging a modem card](#)

## 3.5.8 Wiring

The terminal compartment has a terminal board for connecting communication buses to host systems and field devices. The terminal compartment also has a connection for power supply. Ethernet connections are available for LAN communication.

### Prerequisites

---

#### Note

Ensure that gasket and seats are in good condition prior to mounting the cover in order to maintain the specified level of ingress protection. The same requirements apply for cable inlets and outlets (or plugs). Cables must be properly attached to the cable glands.

---

### Procedure

1. ⚠ Ensure that the power supply is switched off.

#### Note

If any uncertainty exists whether power supply is off or not, ensure that loose cable ends don't run through the cover on the power board.

---

2. ⚠ Loosen the two captive screws and open the lid (see [Figure 3-4](#)).

#### Note

The lid can be removed from the housing for easier access when open more than 25°. Remove the locking ring and carefully slide the lid upwards 21 mm or more. Be careful not to drop it on the floor.

---

3. Run wires through a cable gland. Install wiring with a drip loop in such a way that the lower part of the loop is under the cable entry.
4. Connect wires to the terminal block.
  - See [Figure 3-5](#) for information on terminal block bus connections.
  - See [Wiring diagrams](#) for examples on how to connect the Rosemount 2460 to various host systems and field devices.
  - For wiring of **redundant** system hubs see [Figure 3-18](#).
5. Use the enclosed metal plugs to seal any unused cable entries.
6. ⚠ Tighten the conduits/cable glands.
7. ⚠ Make sure that the Lock ring on the cover to the communication board compartment is folded so that it does not prevent the lid from being properly closed.
8. ⚠ Attach the lid in case it was removed from the housing and close it. Torque the two screws to 4 Nm (35 in.-lb). Ensure that it is fully engaged to prevent water from entering the terminal compartment.

## Front view

Figure 3-4: Rosemount 2460 Front View

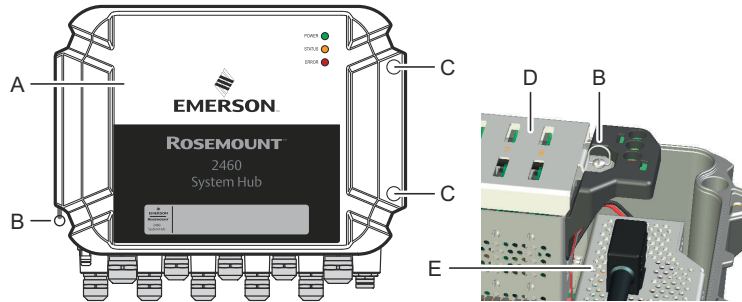

- A. Lid
- B. Lock ring
- C. Captive screws x 2
- D. Cover for communication board compartment
- E. Power Board

### 3.5.9 Terminal board and ports

**Figure 3-5: Ports and Terminals**

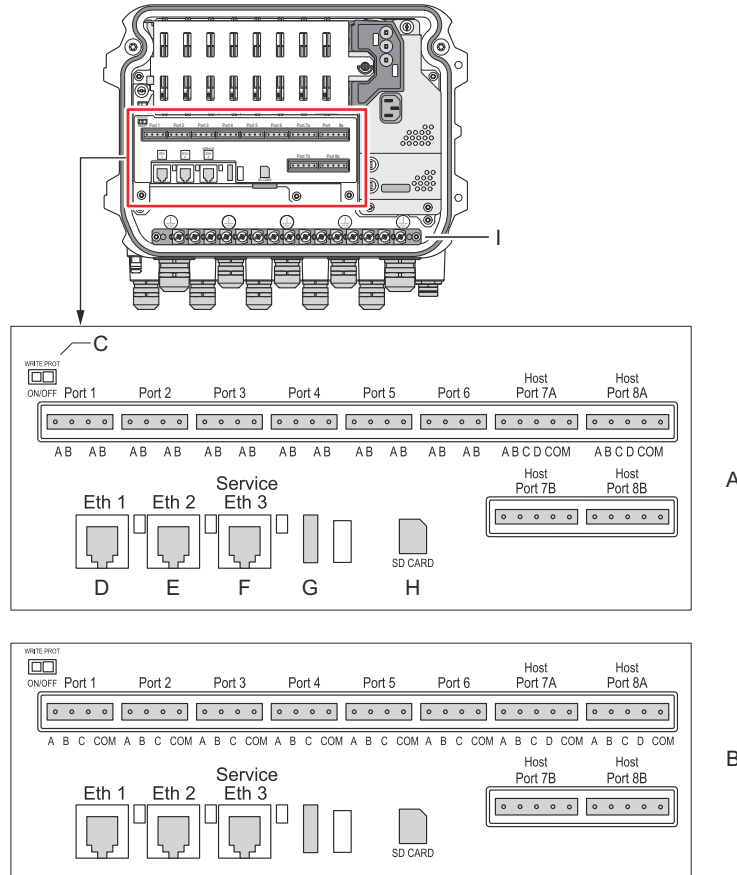

- A. TRL2, RS485, ENRAF
- B. Other interfaces
- C. Write Protection Switch ON/OFF
- D. Ethernet 1
- E. Ethernet 2
- F. Ethernet 3 / Service
- G. USB A 2.0
- H. SD card
- I. Ground bar for cable shield



**Table 3-5: Terminal Assignment**

Terminal	Designation	Function
Port 1	Field device	Communication bus for field devices.
Port 2		
Port 3		
Port 4		
Port 5	Field device/Host	Port 5 and 6 can be configured for field or host communication.
Port 6		
Port 7a	Host/TankMaster	Communication bus for host. Ports designated "a" and "b" are connected in parallel. Supports electrical interface TRL2, RS485, RS422, and RS232.
Port 7b		
Port 8a	TankMaster	Communication bus for TankMaster. Ports designated "a" and "b" are connected in parallel. This port supports electrical interface TRL2, RS485, RS422, and RS232.
Port 8b		
ETH 1	Standard Ethernet port	Ethernet communication bus. ETH1 is used for DCS/host communication via Modbus TCP. In case the Rosemount 2460 is connected to a Local Area Network (LAN) via Modbus TCP, ensure the connection is secure and no unauthorized personnel can grant access.
ETH 2		ETH 2 is an Ethernet communication bus for connection of redundant system hub. ETH 2 is disabled for standalone systems, but enabled for connection to redundant pair in redundant systems.
ETH 3	Service	Ethernet communication bus for service purposes. Use this port to access the Web interface for the 2460.
USB A 2.0	USB	Port for USB stick <sup>(1)</sup> for saving log files.
SD card	SD	Memory card <sup>(1)</sup> reader for saving log files.
Ground bar		For connection of cable shields.

*(1) USB sticks and SD cards should be FAT32 formatted.*

## Pin mapping for 4 pole and 5 pole connectors

**Figure 3-6: Port 1-6 for TRL2, RS485, and Enraf**

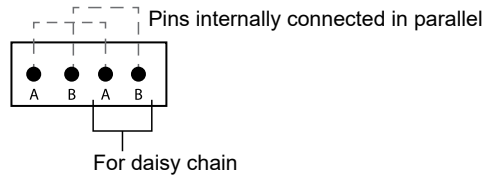

**Figure 3-7: Port 1-6 for Other Interfaces**

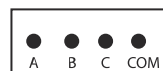

**Figure 3-8: Port 7-8**

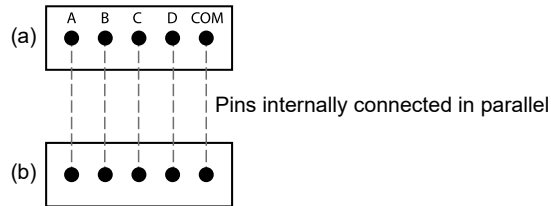

### Related information

[Bus connections](#)

## Bus connections

**Table 3-6: Bus Connections to Port 1 - 6 Standard**

Interface	A	B	A <sup>(1)</sup>	B <sup>(1)</sup>
TRL2	(A and B polarity independent)			
RS485 (2-wire) (Modbus, Whessoe 550/660, GPE) Internally referenced to signal ground	A	B	A	B
Enraf BPM	(A and B polarity independent)			

(1) For daisy-chain

**Table 3-7: Bus Connections to Port 1 - 6 for Emulation**

Interface	A	B	C	COM
Varec Mark/Space <sup>(1)</sup>	Mark	Space	Power <sup>(2)</sup>	Signal ground <sup>(2)</sup>
L&J Tankway <sup>(1)</sup>	Computer	Encoder	Power <sup>(2)</sup>	Signal ground <sup>(2)</sup>
Digital Current Loop (DCL 0-20 mA) (Whessoe 550/660, GPE)	+	-	Power <sup>(3)</sup>	Signal ground <sup>(3)</sup>
Sakura (V1, MDP, BBB)	Loop +	Loop -	Do not use	Do not use
TIC (Tokyo Keiso)	X	Y	Do not use	Do not use

(1) External power supply for powering the bus is required

(2) Input voltage maximum 50 Vdc.

(3) External power input (C=+, COM=-). Only used for external loop power. Do not use if Rosemount 2460 System Hub provides loop power.

**Table 3-8: Bus connections to Host Port 7- 8**

Interface	A	B	C	D	COM
TRL2	(A and B polarity independent)		N/A	N/A	N/A
RS485 / 422 (2-wire) <sup>(1)</sup>	A	B	N/A	N/A	GND
RS485 / 422 (4-wire)	RD + (A')	RD - (B')	TD + (A)	TD - (B)	GND
RS232	RxD	TxD	N/A	N/A	GND

(1) Recommended for redundant systems

## Conductors

Ensure that you use cables suitable for the terminal blocks that are supplied by Emerson for the Rosemount 2460 System Hub.

**Table 3-9: Cables Suitable for Terminal Blocks Supplied by Emerson**

Conductor connection	Maximum (mm <sup>2</sup> )	AWG
Solid	4	11
Flexible	2.5	13
Flexible, Ferrule with plastic collar	1.5	16

**Figure 3-9: Conductor Stripping Length and Cross-sectional Area**

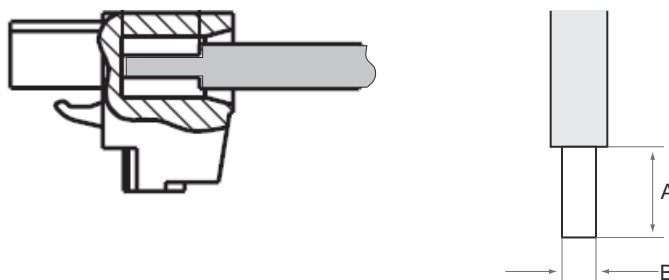

- A. Stripping length: 7 mm
- B. Cross-sectional area, see [Table 3-9](#)

**Figure 3-10: Stripping Length for Connection to Ground Bar**

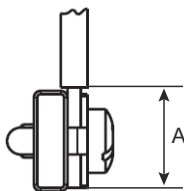

- A. Stripping length: 15 mm

## Cable glands

Figure 3-11: Cable Entries with Glands and External Ground

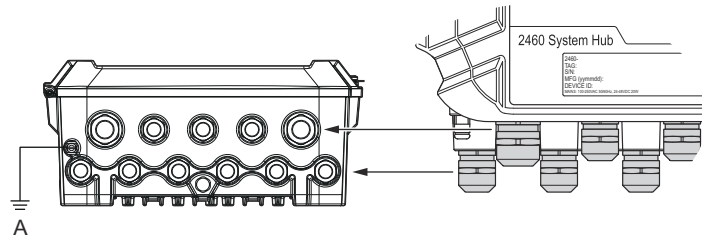

A. External ground

Table 3-10: Tightening Torque (Nm) for Glands Supplied by Emerson

Item	Thread	
	M20	M25
Body	7	10
Top Nut	4	7

Table 3-11: Cable Diameter (mm) for Glands

	Thread	
	M20	M25
Cable Ø	6 - 13	9 - 17

## 3.5.10 Ground lug

**Figure 3-12: Ground Lug Dimensions**

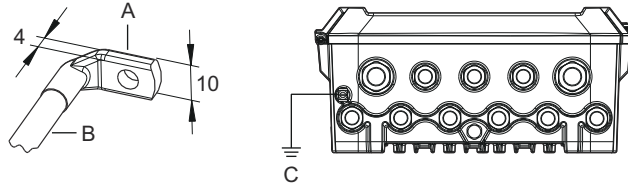

- A. Ground lug
  - Cable lug thickness maximum 4 mm
  - Cable lug height maximum 10 mm
- B. Cable size minimum 4 mm<sup>2</sup> or AWG 11
- C. External ground screw M5

### 3.5.11 Power supply connection

**Figure 3-13: Power Supply Connection**

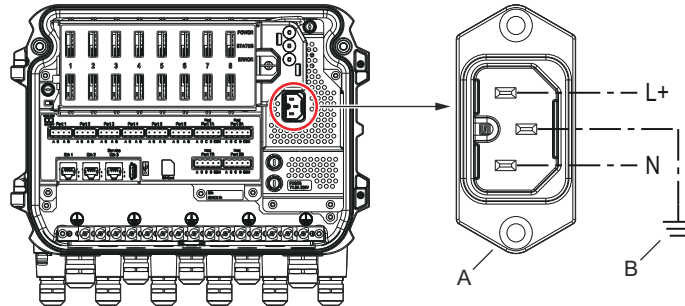

- A. 24 - 48 Vdc; 100 - 250 Vac; 50 - 60 Hz; Max 20 W
- B. Protective ground

#### Related information

[Power supply](#)

#### Power connector

##### Note

Connector is of type IEC C16.

##### Note

Connector is supplied by factory.

**Figure 3-14: Power Connector Supplied by Emerson**

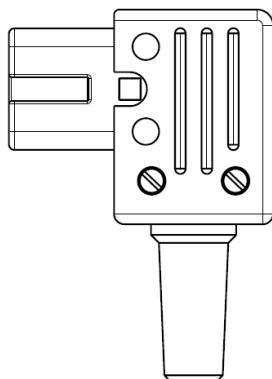

##### Note

Use connector type IEC C16 only.

**Table 3-12: Torque Values for Power Connector Assembly**

Item	Max torque
Terminals	0.8 Nm
Cable clamp	1.2 Nm
Cover	1.2 Nm

## Cable size

**Table 3-13: Cable and Wire Size for Power Cord**

Power cord connector supplied by manufacturer	
Wire (x3)	Max. 2.1 mm <sup>2</sup>
Cable	Max. 10 mm



### 3.5.12 Wiring diagrams

The communication ports can be configured for various combinations of field device and host communication. In the standard configuration Port1 to Port 6 are connected to field devices and Port 7 and Port 8 are used for host communication.

**Figure 3-15: Rosemount 2460 System Hub Connected to Field Devices and TankMaster PC**

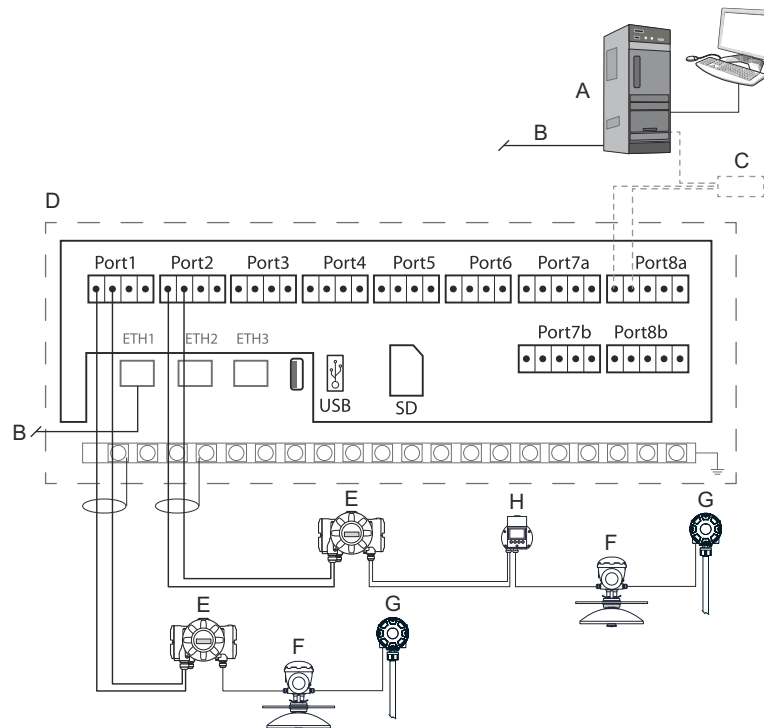

- A. Rosemount TankMaster PC
- B. Ethernet (ETH1)
- C. Rosemount 2180 Field Bus Modem
- D. Rosemount 2460 terminal board
- E. Rosemount 2410 Tank Hub
- F. Rosemount 5900S Radar Level Gauge
- G. Rosemount 2240S Temperature Transmitter
- H. Rosemount 2230 Field Display

Note that the actual configuration of host and field device ports may differ from the examples in this section. See [Connecting to a Rosemount 2460 System Hub](#) for more information on configuration options for the Field and Host ports. See also installation drawings for more information.

Figure 3-16 shows a wiring diagram with a TankMaster host and a Rosemount 2460 connected to field devices from other vendor via ports 1-4.

**Figure 3-16: Rosemount 2460 with Gauges from Other Vendor**

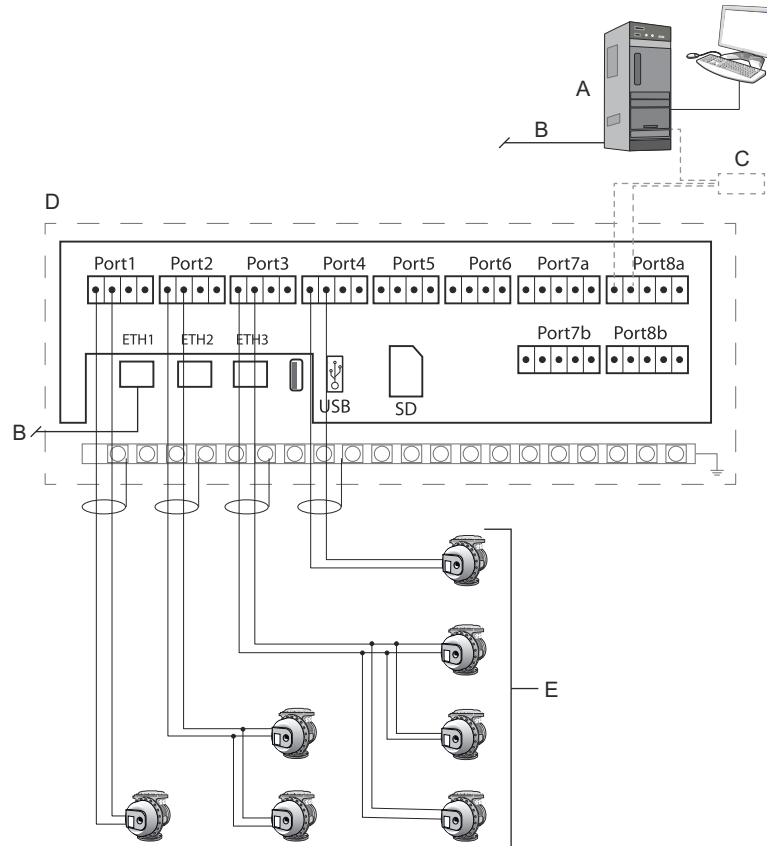

- A. Rosemount TankMaster PC
- B. Ethernet (ETH1)
- C. Rosemount 2180 Field Bus Modem
- D. Rosemount 2460 terminal board
- E. Gauges from other vendor

Figure 3-17 shows a wiring diagram with a Rosemount 2460 connected to a host system via Modbus TCP.

**Figure 3-17: Rosemount 2460 Connected to Host System Via Eth 1 Port and Modbus TCP**

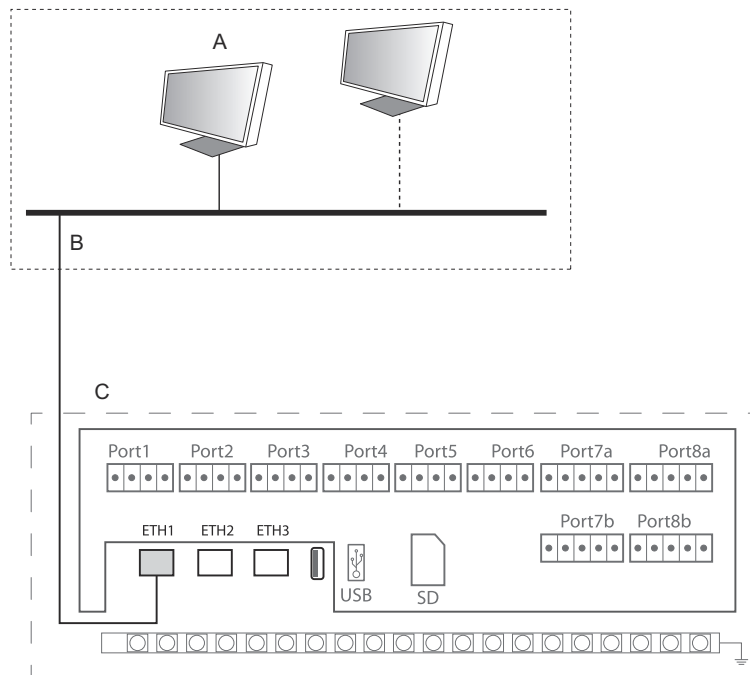

- A. Host system
- B. Modbus TCP
- C. Rosemount 2460 terminal board

Figure 3-18 shows two system hubs in a redundant system. The Primary and Backup system hubs are connected to each other via Ethernet port ETH2.

**Figure 3-18: Example of Wiring Diagram with Redundant Rosemount 2460 System Hubs**

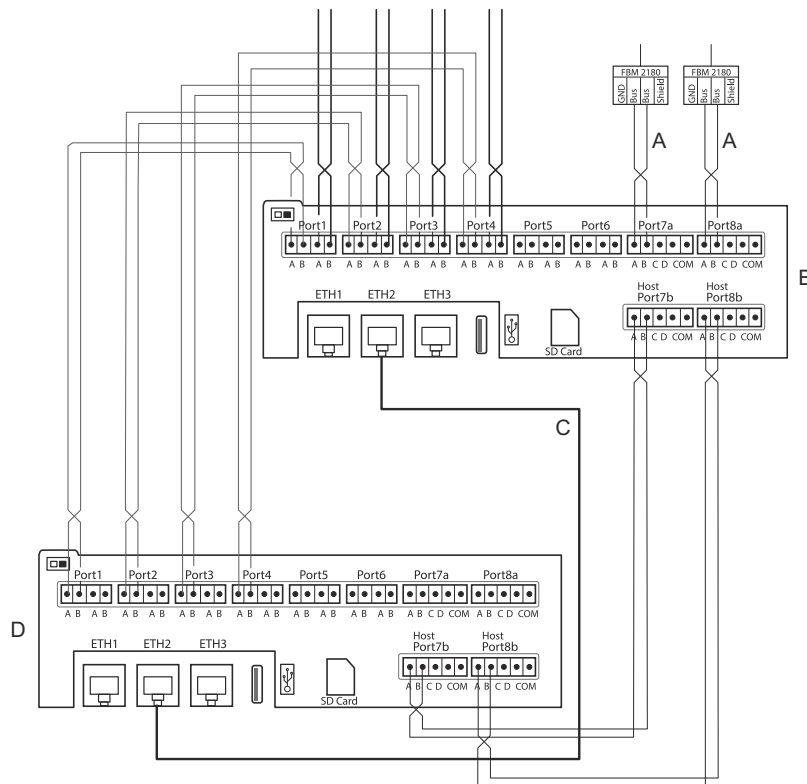

- A. TRL2 bus to host
- B. Rosemount 2460 primary unit
- C. Ethernet cable for redundancy connection
- D. Rosemount 2460 backup unit

Figure 3-19 shows a wiring diagram with a TankMaster host and a Rosemount 2460 connected to Varec, L&J, and DCL field devices.

**Figure 3-19: Rosemount 2460 System Hub Connected to Varec, L&J, and DCL Devices**

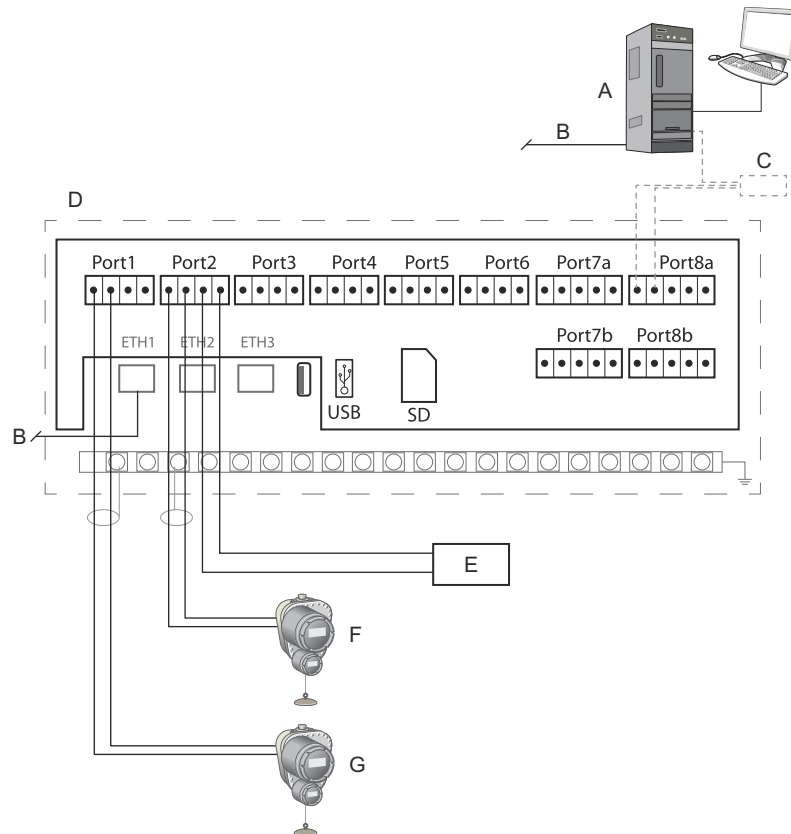

- A. Rosemount TankMaster PC
- B. Ethernet (ETH1)
- C. Rosemount 2180 Field Bus Modem
- D. Rosemount 2460 terminal board
- E. Power: maximum 50 Vdc
- F. Varec, L&J, and DCL devices with external power supply (do not use system hub internal power supply for DCL in this case)
- G. DCL devices using system hub internal power supply (do not use external supply in this case)

Figure 3-20 shows a wiring diagram with Rosemount 2460 emulating Enraf CIU 858. Host port 7 is connected to the Enraf host system. Field ports 1-4 are connected to field devices.

**Figure 3-20: Rosemount 2460 System Hub Connected to Enraf Host System**

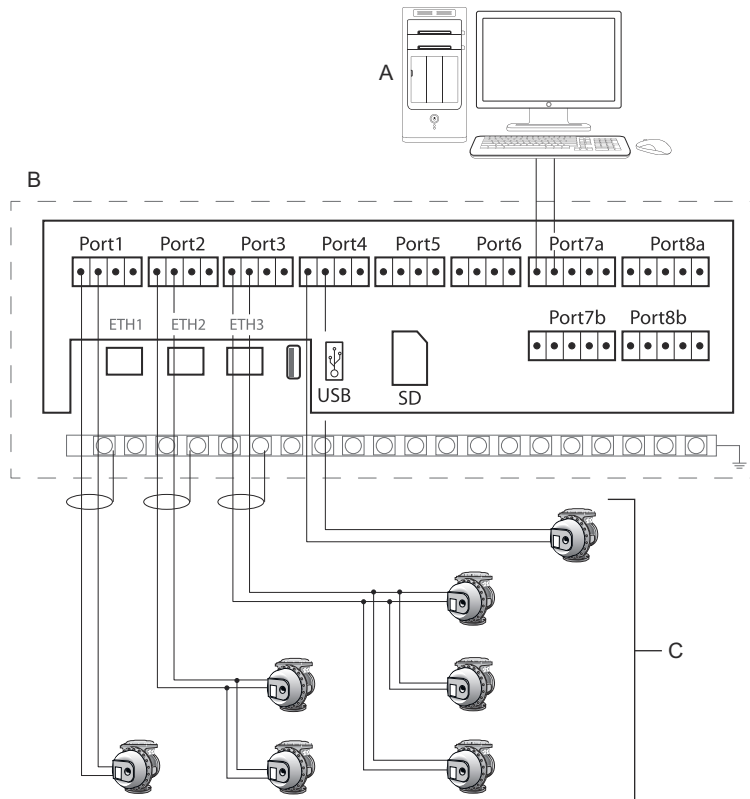

- A. Enraf host system
- B. Rosemount 2460 terminal board
- C. Enraf field devices

**Related information**

- [Electrical installation drawing](#)
- [Communication ports for hosts and field devices](#)
- [Terminal board and ports](#)
- [Connecting to a Rosemount 2460 System Hub](#)

## 4 Configuration

### 4.1 Overview

This section contains information on how to setup a Rosemount 2460 System Hub in a Rosemount Tank Gauging System. The description is based on using the **TankMaster WinSetup** configuration program.

### 4.2 Safety messages

Instructions and procedures in this section may require special precautions to ensure the safety of the personnel performing the operations. Information that potentially raises safety issues is indicated by a warning symbol () . Refer to the following safety messages before performing an operation preceded by this symbol.

#### **WARNING**

**Failure to follow safe installation and servicing guidelines could result in death or serious injury.**

Ensure only qualified personnel perform the installation.

Use the equipment only as specified in this manual. Failure to do so may impair the protection provided by the equipment.

Do not perform any service other than those contained in this manual unless you are qualified.

## 4.3 Setting up a Rosemount 2460 System Hub

### 4.3.1 Introduction

A Rosemount 2460 System Hub is easy to install and configure by using the **TankMaster WinSetup** configuration program. The WinSetup installation wizard guides you through the basic configuration to start up a Rosemount 2460.

Host communication via the Ethernet 1 port (ETH1) and Modbus TCP protocol can be setup by using the Web based Graphical User Interface (GUI).

#### Related information

[Service and troubleshooting](#)

### 4.3.2 Installation procedure

Installation of a Rosemount 2460 System Hub in a Rosemount Tank Gauging system includes the following basic steps:

#### Procedure

1. Ensure that a plan is available for all tanks and devices with tag names, communication addresses, number of temperature elements and other data that is needed for a system setup.
2. In case devices from other vendors will be connected to the field ports, ensure that appropriate modem cards are installed which support the communication protocols. Also, check that the system hub's firmware supports the modem cards and protocols. TankMaster 6.C0 and higher is required for configuration of system hub with Enraf® support.
3. Ensure that the system hub is properly wired and up and running. Check that the Power LED is on and the Status LED indicates normal operation.
4. (Redundancy). Ensure that the two system hubs are properly wired including the cable for redundancy connection.

---

#### Note

Note that configuration of redundant Rosemount 2460 is supported by TankMaster 6.D0 and higher versions.

---

5. Ensure that the **TankMaster WinSetup** configuration program is up and running.
6. In **TankMaster WinSetup**, setup the appropriate protocol channel<sup>(4)</sup> in the TankMaster host PC. This step will ensure that communication between the TankMaster PC and the Rosemount 2460 is established.
7. In **TankMaster WinSetup**, start the device **installation wizard** and configure the system hub :
  - a) In the WinSetup workspace, click the right mouse button on the **Devices** folder and select **Install new**.
  - b) Specify device type (2460) and name tag.
  - c) Check that the correct communication channel is enabled and verify communication with the TankMaster host computer.

---

(4) See the Rosemount Tank Gauging [System Configuration Manual](#) for more information on how to configure communication protocol channels.



- d) Verify that the Host ports and Field ports are using the right protocols for communication with TankMaster work stations or other host systems, and with field devices such as the Rosemount 2410 Tank Hub and the Rosemount 5900S Radar Level Gauge.
  - e) Configure the tank database. See configuration examples that illustrate how the tank databases of the Rosemount 2460 and the Rosemount 2410 are related to each other in [Tank databases of the Rosemount 2460 and the Rosemount 2410](#). Configuration of Enraf devices is covered by section [Enraf® device configuration](#). Configuration of Whessoe WM550/660 devices is described in [Whessoe device configuration](#).
  - f) (Redundancy). Perform a redundancy configuration in case the system has a pair of redundant system hubs. This is included as part of the installation wizard.
  - g) Finish the installation wizard and verify that the system hub appears in the Rosemount TankMaster workspace. Now the Rosemount 2460 will be able to communicate with the host system and collect data from field devices.
8. In case the Rosemount 2460 communicates with a host system via the Ethernet 1 port and Modbus TCP protocol, open the Web based Graphical User Interface for configuration.

#### Related information

[Rosemount Tank Gauging System Configuration manual](#)

[Installation wizard](#)

[Wiring](#)

[Wiring diagrams](#)

[Status LED](#)

[Redundancy configuration](#)

[Exchanging a modem card](#)

[Service and troubleshooting](#)

[Specifications and reference data](#)

## System architecture

Figure 4-1: Rosemount Tank Gauging System Architecture

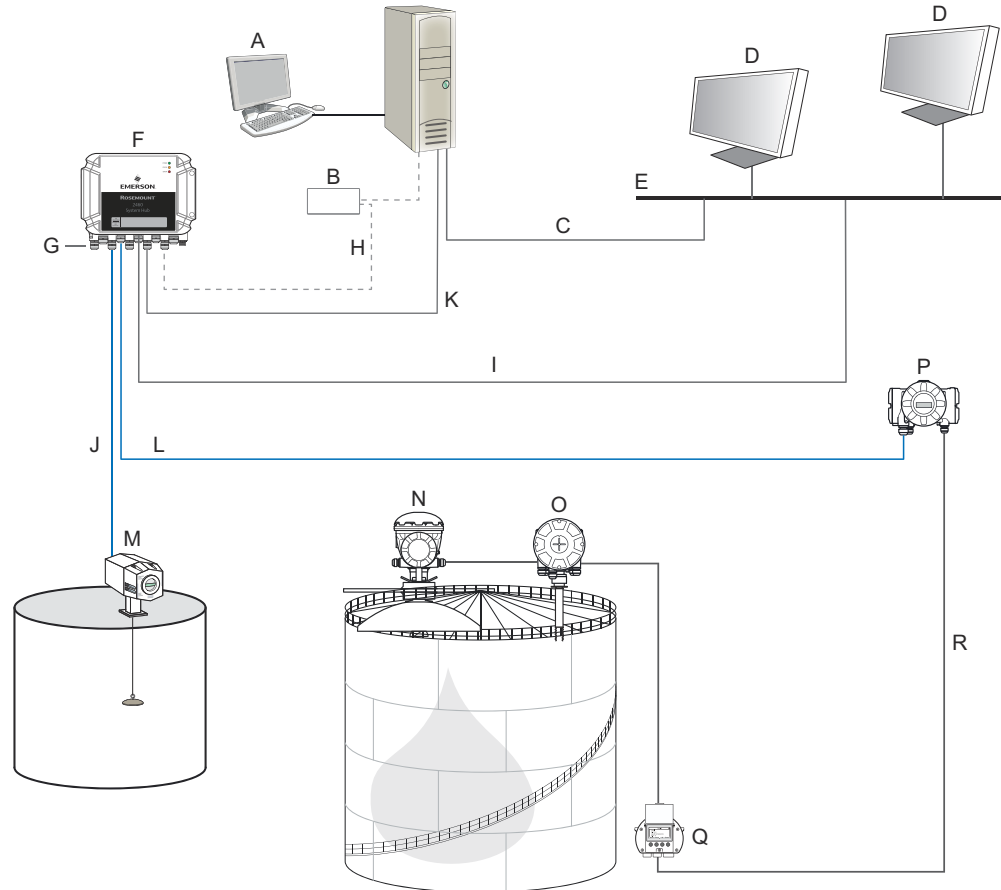

- |    |                           |    |  |
|----|---------------------------|----|--|
| A. | Rosemount TankMaster      | J. | TRL2, Enraf BPM, DCL, RS485                |
| B. | Modem                     | K. | Modbus TCP (Ethernet)                      |
| C. | Modbus TCP (Ethernet)     | L. | TRL2, RS485                                |
| D. | Host/DCS                  | M. | Gauges and transmitters from other vendors |
| E. | Plant network             | N. | Rosemount 5900S Radar Level Gauge          |
| F. | Rosemount 2460 System Hub | O. | Rosemount 2240S Temperature Transmitter    |
| G. | Field/Host Ports          | P. | Rosemount 2410 Tank Hub                    |
| H. | TRL2, RS232, RS485        | Q. | Rosemount 2230 Display                     |
| I. | Modbus TCP (Ethernet)     | R. | Tankbus                                    |

### Related information

[Terminal board and ports](#)

### 4.3.3 Installation wizard

This section describes how to install and configure a Rosemount 2460 System Hub by using the WinSetup installation wizard.

#### Step 1. Select device type

##### Procedure

1. In the **WinSetup** workspace, click the right mouse button on the **Devices** folder.

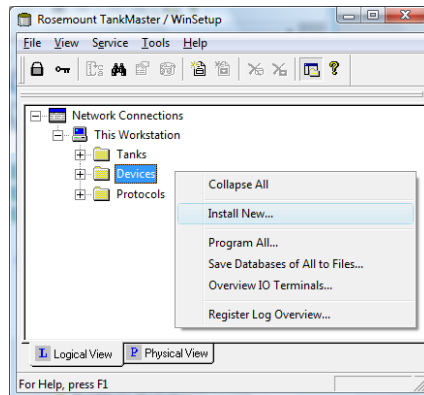

2. Select **Install new**.

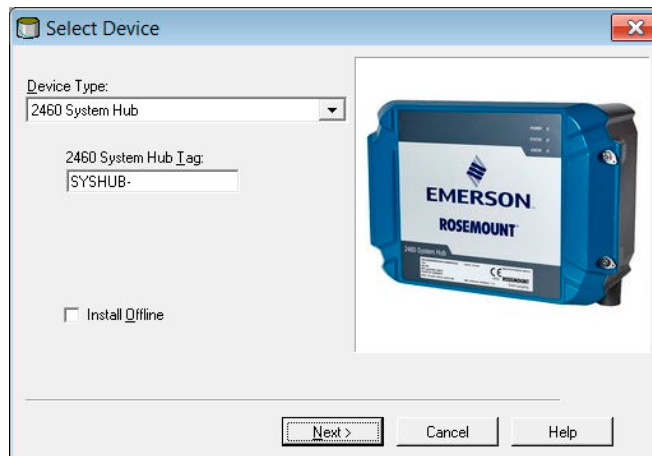

3. Select device type:
  - a) Choose device type **2460 System Hub**.
  - b) Specify a name for the System Hub in the **2460 System Hub Tag** input field.  
This tag will be used as an identifier of the Rosemount 2460 in various windows and dialogs. The TankMaster program automatically suggests the first part of the name as specified in the **Tag Prefixes** window (**Service** → **Preferences**).
4. Click the **Next** button to continue the installation procedure with communication setup.

## Step 2. Communication setup

### Procedure

1. Verify that the correct communication protocol channel is used.

A communication channel needs to be associated with a specific port (Ethernet/USB/COM) on the TankMaster workstation in order to communicate with a Rosemount 2460.

2460 System Hub Communication - SYSHUB-201

Communication Channel: ModbusMaster.1

IP Address: 10.69.208.13:502

Modbus Address: 201 Change Address...

Device ID: 1420000122 Verify Communication

< Back Next > Cancel Help

2. Verify that the system hub communicates with the TankMaster PC.

The system hub supports many communication interfaces such as Ethernet, TRL2, RS232, and RS485.

- a) To verify communication, enter the system hub's **Modbus Address** and click the **Verify Communication** button.  
The **Device ID** will appear if the correct Modbus Address was entered (the Rosemount 2460 is shipped with the default Modbus address=245).
- b) In case you would like to change the current Modbus address, or the address is unknown, click the **Change Address on Device** button.

---

#### Need help?

In case several system hubs are connected using the same default address (245), you will have to change the addresses of the system hubs before the **Verify** command can be used.

---

3. Click the **Next** button to continue the installation procedure.

---

#### Note

Host communication via the Ethernet 1 port and Modbus TCP must be configured via the Web based graphical user interface.

---

### Related information

- [Check communication channel properties](#)
- [Change the system hub's Modbus address](#)

## Check communication channel properties

### Procedure

1. To check which channel is enabled:
  - a) In the WinSetup workspace open the **Protocols** folder.

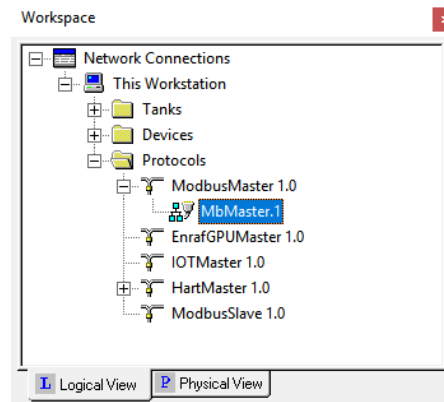

- b) Expand the master protocol folder (ModbusMaster 1.0 in this example)
  - c) Check that the appropriate channel is enabled (**MbMaster.1** in this example). Disabled channels do not appear in the protocol folder.
2. To check which communication type that is used:
    - a) Right-click the desired protocol channel icon and select **Properties**.

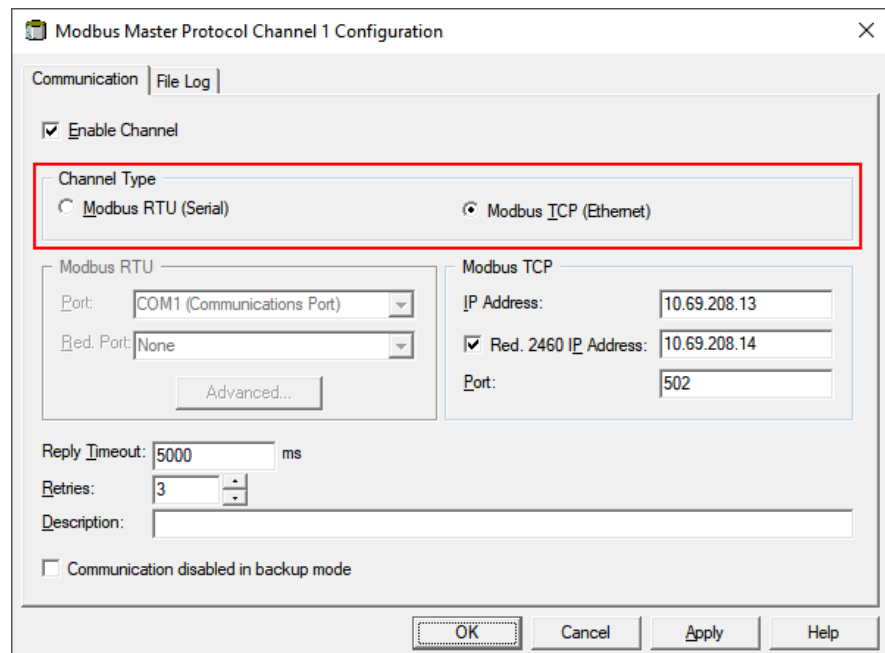

- b) Open the **Communication** tab and check which communication channel type that is selected.

#### Example

This example shows that **Modbus TCP** over Ethernet is used for Protocol Channel 1. The **Modbus RTU** options means that the system hub communicates via Host ports.

See the Rosemount Tank Gauging [System Configuration Manual](#) (Document no. 00809-0300-5100) for more information on how to configure communication protocols.

## Change the system hub's Modbus address

### Procedure

1. In the **2460 Communication** window, click the **Change Address on Device** button to open the **Change Address** window.

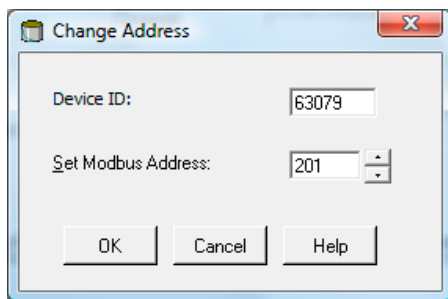

2. Enter the **Device ID** and the new **Modbus address**.

For the Rosemount 2460 System Hub it is recommended to use addresses starting from 201. When changing the device address, the **Device ID** is used as a unique identifier. The **Device ID** can be found on a label mounted on the device.

---

#### Tip

If there is no other device connected that uses the same address as the current device, you can find the Device ID by typing the address into the Address field in the **Rosemount 2460 System Hub Communication** window and clicking the **Verify Communication** button.

---

3. Click the **OK** button to confirm the settings and close the **Change Address** window.
4. In the **Rosemount 2460 System Hub Communication** window click the **Verify Communication** button to check if communication is established between the TankMaster work station and the Rosemount 2460 System Hub. The **Device ID** will appear when TankMaster finds the system hub.

## Step 3. Port configuration

### Procedure

1. Verify that the correct modem (TRL2, RS485, Enraf<sup>®</sup>, Digital Current Loop (DCL)) is installed, and communication ports are properly configured.

In most cases there is no need to change any communication parameters. Standard configuration is automatically set for each modem type. The **Advanced** button allows you to change communication parameters in case the standard settings are not sufficient for specific requirements.

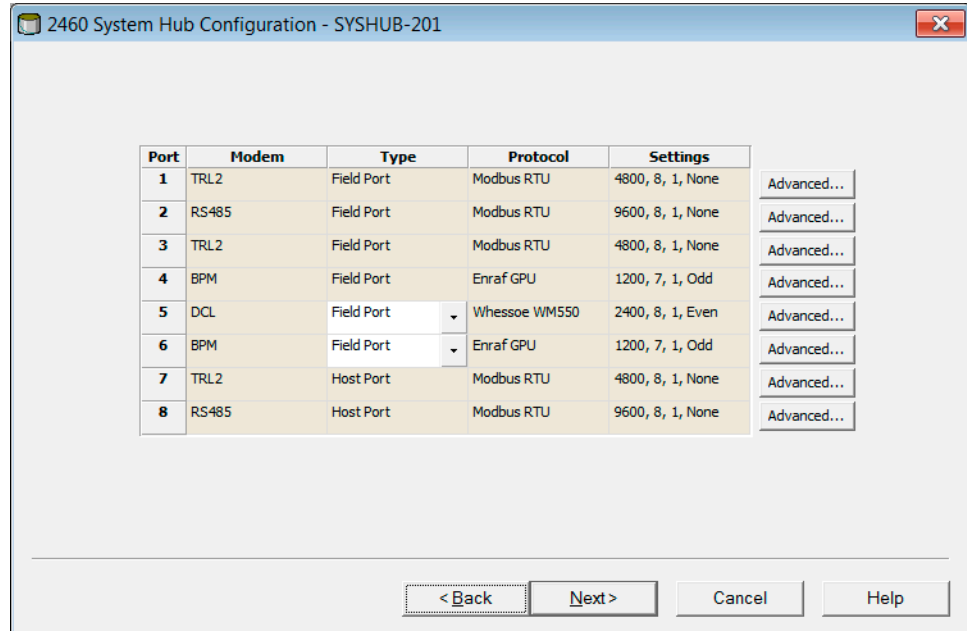

- a) **Modem.** The Rosemount 2460 supports a large number of modem types. Verify that correct modem is installed on each port to be used.
- b) **Port Type.** The Rosemount 2460 has eight communication ports. They are normally configured as six **Field** ports and two **Host** ports. Host ports can be connected to TankMaster work stations as well as other hosts. The Field ports are connected to Rosemount 2410 Tank Hubs and other supported field devices.
- c) **Protocol.** The Modbus protocol is the standard option in Rosemount Tank Gauging systems. However, other protocols are supported as well. For protocols which are not automatically detected by the system hub, you may configure communication protocol and parameters manually by clicking the **Advanced** button (see [Step 2](#) below).
- d) **Settings.** Verify the communication parameters.

2. Optional: Communication parameters for Host and Field ports can be configured in the **Advanced Port Configuration** window (click the **Advanced** button).

- a) Select the desired protocol and configure the communication parameters.
  - b) Click the **Apply** button to save the current configuration.
  - c) Click the **OK** button to return to the **Rosemount 2460 System Hub Configuration** window.
3. In the **Rosemount 2460 System Hub Configuration** window, click the **Next** button to continue the installation procedure.

### Related information

[Communication/configuration specifications](#)  
[Connecting to a Rosemount 2460 System Hub](#)  
[Default communication parameters](#)  
[Modem cards](#)

### Advanced port configuration window

The **Advanced Port Configuration**<sup>(5)</sup> window lets you change from standard to a non-standard port configuration. This is a useful option if, for example, the Rosemount 2460 System Hub is connected to a host that requires manual configuration of protocol and communication parameters. Non-standard settings may also be needed in case field devices connected to different field ports use different communication parameters such as baud rate. Then each port can be configured independently of the other ports.

Non-standard settings may also be required in case the system hub is located far away from the host since maximum communication speed for RS232 and RS485 depends on the cable length.

Some emulation protocols use the same type of modem card. Therefore, you may need to specify communication protocol and configure parameters for the particular protocol to be used.

<sup>(5)</sup> Some modems must be configured with DIP switches.



**Table 4-1: Advanced port configuration**

Parameter	Description
<b>Reply timeout and Number of retries</b>	For Field Ports the <b>Reply timeout</b> and <b>Number of retries</b> parameters can be adjusted in case a connected field device responds slowly to queries from the Rosemount 2460. The default setting is sufficient in most cases.
<b>Min/max response time</b>	For Host Ports the <b>Min response time</b> and <b>Max response time</b> define the time slot in which a response from the Rosemount 2460 will be sent to a host system. If needed, you may change these parameters to match the requirements for a particular host system.
<b>Min Rx to Tx delay time</b>	For field ports a delay time between receive and transmit messages can be used for devices that need more time to get ready to receive the next query e.g. TIC devices.
<b>Single Port Mode</b>	In case of cross talks between field port buses, it is possible to configure affected ports to be silent while communication is ongoing on a port in single port mode. For the configuration to have an effect, two or more field ports must be enabled for Single Port Mode. If all field ports are enabled for Single Port Mode, no concurrent communication among the field ports can occur at all. This configuration has no effect if the Port is configured for host mode which is an option for ports 5 and 6.
<b>Redundant field ports</b>	The <b>Redundant Field Ports</b> functionality is supported for TRL2 and RS485 interface and requires <b>license</b> for redundant system hubs. Two field ports can be configured in a redundant primary/backup pair. If the primary port has communication problems with a specific device(s), the backup port will take over communication with this device(s) after a number of retries. Status of the passive port is checked at regular intervals. A switch over to backup port will only take place if status of the backup port is OK. If the backup port is active, and primary port status is back to normal, a switch over will take place once the status check is done.

**Related information**

[Modem cards](#)

**Default communication parameters**

**Table 4-2: Modbus Communication Parameters for Rosemount 2460 Host Ports**

Interface	Parameters			
	Baud rate	Data bits per character	Stop bits	Parity
TRL2	4800	8	1	None
RS485	9600	8	1	None
RS232	19200	8	1	None

**Table 4-3: Communication Parameters for Rosemount 2460 Field Ports**

Interface	Parameters			
	Baud rate	Data bits per character	Stop bits	Parity
TRL2	4800	8	1	None
RS485	9600	8	1	None
Enraf BPM	1200	7	1	Odd
Digital Current Loop	2400	8	1	Even
Varec Mark/Space	250	8	1	None
L&J Tankway	1200	8	1	Even
TIC	2400	8	1	Even
Sakura	2400	8	1	None
GPE	300	7	1	Odd

**Related information**

Digital communication protocols

**Step 4. Configure the tank database**

The tank database of the Rosemount 2460 System Hub ensures that the system hub requests information from all the connected field devices.

**Procedure**

1. Find first<sup>(6)</sup> free tank position (2460 Tank 1, 2, 3...) for the device to be configured.
2. Select the appropriate **Source** device.

For a Rosemount Tank Gauging system this is typically a Rosemount 2410 Tank Hub. The Rosemount 2460 System Hub also supports many other Rosemount Tank Gauging devices as well as devices from other vendors.

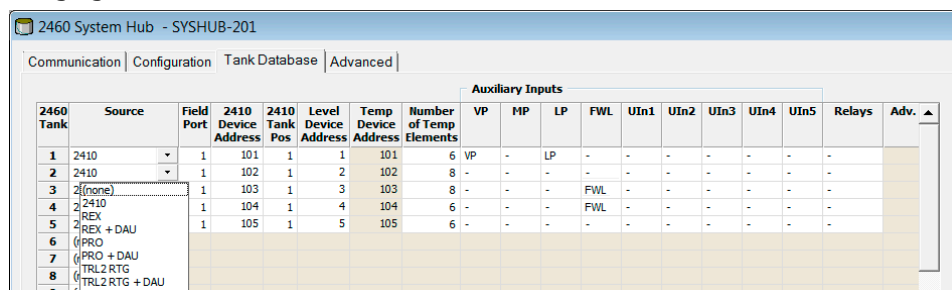

3. Select the **Field Port** that the device is connected to.  
In the standard configuration there are six field bus ports available for a Rosemount 2460 System Hub. The TRL2 bus is the standard field bus interface.

<sup>(6)</sup> Note that empty tank positions in between configured tank positions will show up in the Web interface as empty tanks without any data.

4. Enter the **2410 Device Address** for each Rosemount 2410 Tank Hub that is connected to the system hub.

---

**Note**

Note that for 2410 Tank Position 1 the same address will be used for the temperature device and the tank hub itself. This is done automatically by TankMaster.

---

5. Enter the appropriate **2410 Tank Position**.

All field devices on a certain tank are associated with the same position in the Rosemount 2410 Tank Hub's tank database. For a Rosemount 2410 connected to a single tank, all field devices are configured in Tank Position 1.

Use Tank Position 2-10 for the multiple tanks version of the Rosemount 2410 Tank Hub. It has a database with 10 tank positions that allows the tank hub to serve up to ten tanks. Each row in the tank database of the Rosemount 2460 System Hub corresponds to a tank position in the database of the Rosemount 2410 Tank Hub.

---

**Important**

The Tank Database of the Rosemount 2460 System Hub must be properly configured to match the tank databases of all Rosemount 2410 Tank Hubs connected to the system hub.

---

6. Enter **Level Device Address** for devices such as the Rosemount 5900 Radar Level Gauge and other level gauges supported by the Rosemount 2460 System Hub and the Rosemount 2410 Tank Hub.
7. In case the level gauge is a Rosemount 5900S 2-in-1 version, you will need to configure two level device addresses.  
See the Rosemount Tank Gauging [System Configuration Manual](#) (Document No. 00809-0300-5100) for a detailed description of how to configure the tank database for a Rosemount 5900S Radar Level Gauge 2-in-1 version.

8. Enter the **Temperature Device Address**.

For "2410 tank position" 1 the same address is used for the Rosemount 2410 Tank Hub and the temperature device. The tank hub's address is automatically copied to the Temperature Device Address field.

For "2410 Tank Position" 2 to 10 you will have to enter the same temperature device addresses as configured in the Rosemount 2410 Tank Hub's tank database. Each tank position must have a unique address.

---

**Note**

The **Temp Device Address** in the Rosemount 2460's tank database is referred to as the ATD Modbus Address in the Rosemount 2410 Tank Hub's tank database.

---

9. Enter the number of elements in the **Number of Temperature Elements** column in case temperature elements are installed in the tank.  
The position of the temperature elements need to be configured to allow calculation of average product temperature. This is normally done as part of the standard installation procedure for the Rosemount 2410 Tank Hub and the associated temperature transmitters as described in the Rosemount Tank Gauging [System Configuration Manual](#) (Document no. 00809-0300-5100).
10. Select the **Auxiliary Inputs** that are used for the device such as Free Water Level (FWL), Vapor Pressure (VP), and Liquid Pressure (LP).

11. In the **Relays** column, select **2410** if a Rosemount 2410 Tank Hub with relay output is connected to the Rosemount 2460 System Hub. Then the 2460 input registers will be continuously updated with current status of the 2410 relay outputs. Leave empty if no relays are used.

---

**Note**

Ensure that the Tank Database is properly verified before proceeding. Check all addresses and parameters for each tank and source device.

---

**Related information**

[Tank database entry fields](#)

[Connecting to a Rosemount 2460 System Hub](#)

[Tank databases of the Rosemount 2460 and the Rosemount 2410](#)

[Enraf device configuration](#)

[Whessoe device configuration](#)

[L&J device configuration](#)

[Varec device configuration](#)

[TIC configuration](#)

[Sakura configuration](#)

[NRF590 configuration](#)

**Tank database configuration**

The tank database of the Rosemount 2460 System Hub ensures that the system hub requests information from all the connected field devices. It is very important that the Tank Database of the Rosemount 2460 System Hub is properly configured to allow communication between the Rosemount 2460, the Rosemount 2410 Tank Hub, and field devices such as the Rosemount 5900S Radar Level Gauge, the Rosemount 2240S Multi-Input Temperature Transmitter, pressure transmitters, and other field devices supported by the system hub.

Figure 4-2: Tank Database

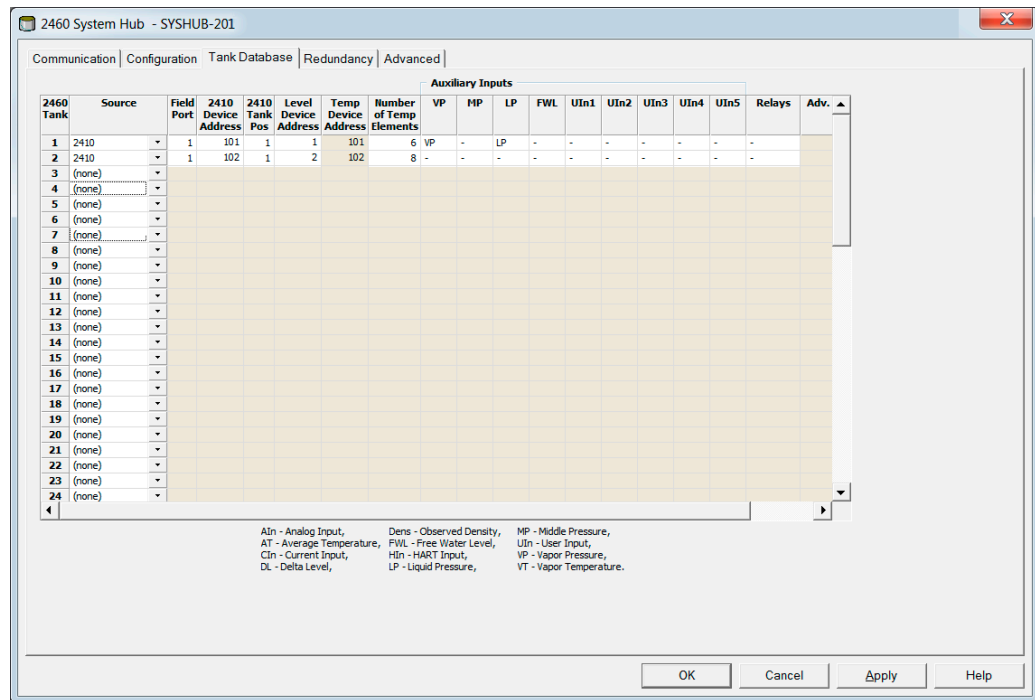

**Note**

Once all devices and tanks are installed and configured, the position of a device in the Tank Database may not be changed, since this will result in corrupt mapping of tank to Tank Database position.

**Level device address**

The **Level Device Address** field in the tank database of the Rosemount 2460 System Hub is used for level gauges such as the Rosemount 5900. This address also needs to be stored in the tank database of the Rosemount 2410 Tank Hub.

Normally, address configuration is done as part of the installation procedure of the Rosemount 2410 as described in the Rosemount Tank Gauging [System Configuration Manual](#) (Document No. 00809-0300-5100).

**Temperature device address**

The **Temperature Device Address** in the tank database of the Rosemount 2460 System Hub is a common address for all devices (ATD) on a tank except level gauges. The **Temperature Device** address also needs to be stored in the tank database of the Rosemount 2410 Tank Hub. For the tank hub this address is referred to as the **ATD Modbus** address.

Configuration of the Rosemount 2410 tank database is normally done as part of the installation procedure of the Rosemount 2410 as described in the Rosemount Tank Gauging [System Configuration Manual](#) (Document No. 00809-0300-5100).

For the first tank position in the Rosemount 2410 tank database, the Rosemount 2410 Modbus address is automatically set as the ATD Modbus address.

It is recommended that address range 1 to 99 is used for level gauges and 101 to 199 for ATD devices.

See also section “Installing a Rosemount 2410 Tank Hub” in the Rosemount Tank Gauging System Configuration Manual (Document No. 00809-0300-5100).

### Related information

[Tank databases of the Rosemount 2460 and the Rosemount 2410](#)

## Tank database entry fields

**Table 4-4: Entry Fields for the Tank Database**

Entry field	Description
Source	<ul style="list-style-type: none"> <li>• 2410 Tank Hub</li> <li>• Rex</li> <li>• Rex + DAU</li> <li>• Pro</li> <li>• Pro + DAU</li> <li>• TRL2 RTG</li> <li>• TRL2 RTG + DAU</li> <li>• Enraf<sup>(1)</sup> (811, 813, 854, 873, 894, 970, 971, TOI-B)</li> <li>• Whessoe <sup>(2)</sup> (550, 660)</li> <li>• L&amp;J<sup>(3)</sup> (MCG 2000, MCG 1500XL)</li> <li>• Varec<sup>(3)</sup> (1800, 1900)</li> <li>• TIC</li> <li>• Sakura</li> </ul>
Field port	The field bus port that the selected device is connected to. Up to six field ports may be used.
2410 Device Address	Modbus address for the connected Rosemount 2410 Tank Hub. Address range 101 to 199 is recommended.
2410 Tank Position	Each tank is associated with a certain position in the tank database of the Rosemount 2410 Tank Hub. Devices on a tank must be configured with a tank position that refers to the actual tank where the device is installed.
Level Device Address	Communication address for the connected level device. For level gauges address range 1 to 99 is recommended.
Temperature Device Address	Communication address for the connected Temperature/ATD device. For Temperature/ATD devices address range 101 to 199 is recommended.
Number of Temperature Elements	Number of temperature elements connected to the temperature transmitter (for example a Rosemount 2240S Multi-Input Temperature Transmitter).

*(1) Enraf option is supported for Rosemount 2460 firmware version 1.B0 and higher .*

*(2) Whessoe option is supported for Rosemount 2460 firmware version 1.D0 and higher.*

*(3) L&J and Varec options are supported for Rosemount 2460 firmware version 1.E0 and higher*

### Related information

[Communication ports for hosts and field devices](#)

[Enraf device configuration](#)  
[Whessoe device configuration](#)  
[L&J device configuration](#)  
[Varec device configuration](#)  
[TIC configuration](#)  
[Sakura configuration](#)

## Tank Database entry fields Auxiliary inputs

**Table 4-7: Entry fields for Rosemount 2410**

Entry field	Description
2410 Tank Hub	<ul style="list-style-type: none"> <li>• Vapor Pressure</li> <li>• Middle Pressure</li> <li>• Liquid Pressure</li> <li>• Free Water Level</li> <li>• User Inputs 1 - 5</li> <li>• Relays</li> <li>• Delta Level (Uin=DL, tank position 1 only)</li> </ul>

**Table 4-8: Entry fields for Enraf**

Entry field	Description
Enraf	Enraf <sup>(1)</sup> <ul style="list-style-type: none"> <li>• Vapor Pressure</li> <li>• Middle Pressure</li> <li>• Liquid Pressure</li> <li>• Free Water Level</li> <li>• Observed Density (UIn1=Dens)</li> </ul>

*(1) Enraf option is supported for Rosemount 2460 firmware version 1.B0 and higher.*

**Table 4-9: Entry fields for Whessoe**

Entry field	Description
Whessoe	Whessoe 550 <sup>(1)</sup> <ul style="list-style-type: none"> <li>• Vapor Pressure<sup>(2)</sup></li> <li>• Liquid Pressure<sup>(2)</sup></li> </ul> Whessoe 660 <ul style="list-style-type: none"> <li>• None</li> </ul>

*(1) Whessoe option is supported for Rosemount 2460 firmware version 1.D0 and higher.*

*(2) Vapor or Liquid pressure can be selected, not both.*

**Table 4-10: Entry fields for Varec**

Entry field	Description
Varec	Varec <sup>(1)</sup> <ul style="list-style-type: none"> <li>None</li> </ul>

*(1) L&J and Varec options are supported for Rosemount 2460 firmware version 1.E0 and higher.*

**Table 4-11: Entry fields for L&J**

Entry field	Description
L&J	L&J <sup>(1)</sup> <ul style="list-style-type: none"> <li>Vapor Pressure</li> <li>Liquid Pressure</li> <li>Free Water Level</li> <li>Observed Density (UIn1=Dens)</li> </ul>

*(1) L&J and Varec options are supported for Rosemount 2460 firmware version 1.E0 and higher.*

**Table 4-12: Entry fields for TIC**

Entry field	Description
TIC	TIC <ul style="list-style-type: none"> <li>Observed Density</li> </ul>

**Table 4-13: Entry fields for Sakura**

Entry field	Description
Sakura	Sakura BBB/MDP <ul style="list-style-type: none"> <li>None</li> </ul>
	Sakura V1 <ul style="list-style-type: none"> <li>Vapor Pressure</li> <li>Middle Pressure</li> <li>Liquid Pressure</li> <li>Free Water Level</li> <li>Observed Density</li> <li>User Inputs 1 - 3</li> </ul>

**Related information**

- [Communication ports for hosts and field devices](#)
- [Enraf device configuration](#)
- [Whessoe device configuration](#)
- [L&J device configuration](#)
- [Varec device configuration](#)
- [TIC configuration](#)



Sakura configuration

**Tank database entry fields Advanced**

**Table 4-14: Entry fields for the Tank Database Advanced**

Entry field	Description
Advanced	Rosemount 2410 <ul style="list-style-type: none"> <li>• Average Product Temperature</li> <li>• Average Product and Vapor Temperature</li> </ul> Enraf <sup>(1)</sup> <ul style="list-style-type: none"> <li>• Vapor temperature</li> <li>• Fast polling</li> </ul> Whessoe 550 <sup>(2)</sup> <ul style="list-style-type: none"> <li>• Fast polling</li> </ul> Whessoe 660 <ul style="list-style-type: none"> <li>• Vapor temperature</li> </ul> Varec <sup>(3)</sup> <ul style="list-style-type: none"> <li>• Level range</li> <li>• Fast polling</li> </ul> L&J <sup>(3)</sup> <ul style="list-style-type: none"> <li>• Inverse Temperature Sign</li> <li>• Swap Interface and Pressure</li> <li>• No Response if Invalid Level</li> <li>• Fast polling</li> </ul> TIC <ul style="list-style-type: none"> <li>• Average Product Temperature</li> <li>• Advanced Fast polling</li> </ul> Sakura BBB/MDP <ul style="list-style-type: none"> <li>• Advanced Fast polling</li> </ul> Sakura V1 <ul style="list-style-type: none"> <li>• Average Product temperature</li> <li>• Average Product and Vapor temperature</li> <li>• Advanced Fast polling</li> </ul>

(1) Enraf option is supported for Rosemount 2460 firmware version 1.B0 and higher.  
 (2) Whessoe option is supported for Rosemount 2460 firmware version 1.D0 and higher.  
 (3) L&J and Varec options are supported for Rosemount 2460 firmware version 1.E0 and higher.

**Related information**

- [Communication ports for hosts and field devices](#)
- [Enraf device configuration](#)
- [Whessoe device configuration](#)
- [L&J device configuration](#)

[Varec device configuration](#)  
[TIC configuration](#)  
[Sakura configuration](#)

## Step 5. Redundancy

This step lets you setup a redundant pair of system hubs.

### Procedure

1. Click the **Create New Pair** button to start the redundancy synchronization procedure.

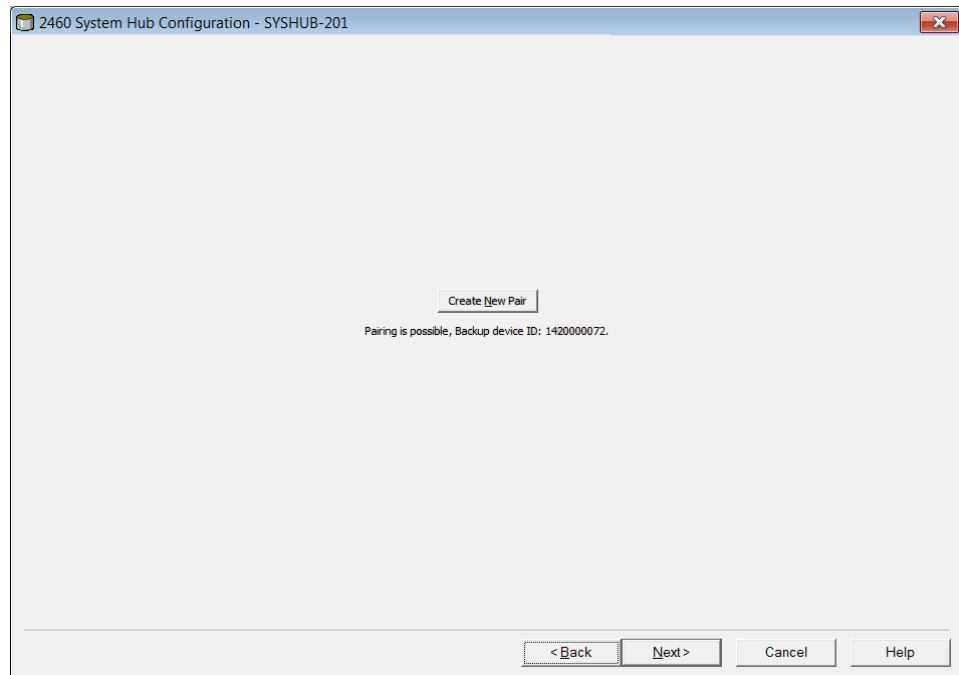

2. When finished, a message appears that the database synchronization was successfully completed. The system hubs will be paired as a **Primary** and a **Backup** device.

For standalone system hubs, click **Next** to skip this step and proceed with the installation procedure.

### Related information

[Redundancy configuration](#)  
[Step 6. Finish the installation](#)

## Step 6. Finish the installation

### Procedure

1. Verify that the Tag, Device ID, communication channel, and Modbus Address presented in the **2460 System Hub Summary** window are correct.

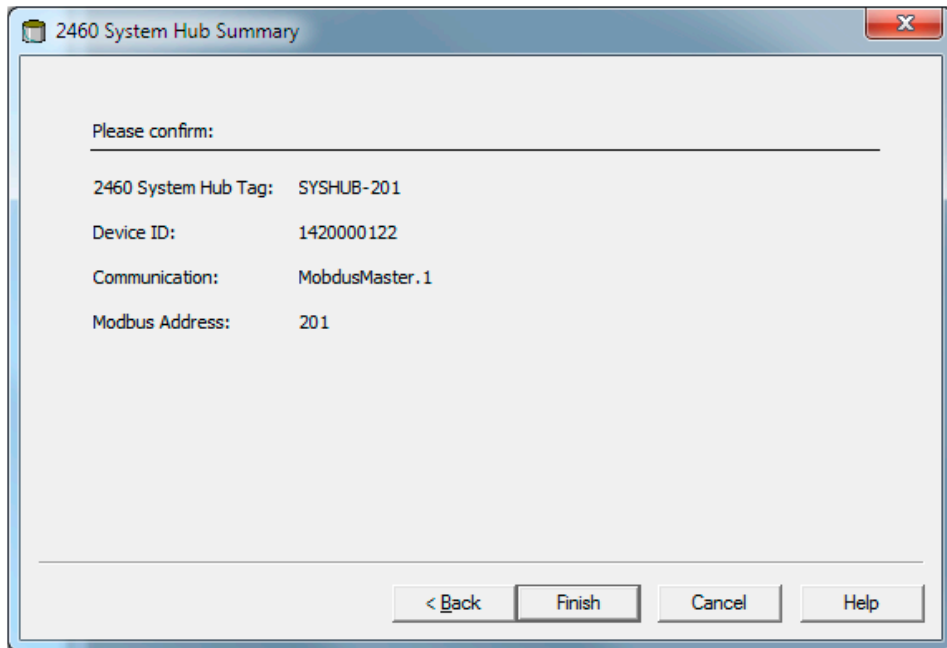

2. In case you would like to make any changes in the preceding steps, click the **Back** button until the desired window appears.
3. Click the **Finish** button to confirm the installation.

4. Verify that the Rosemount 2460 System Hub appears in the TankMaster workspace window.

**Figure 4-3: Rosemount 2460**

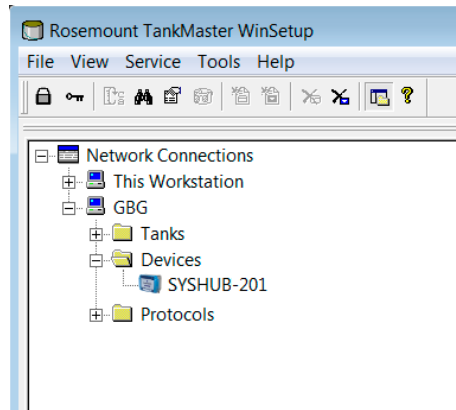

**Figure 4-4: Redundant Rosemount 2460**

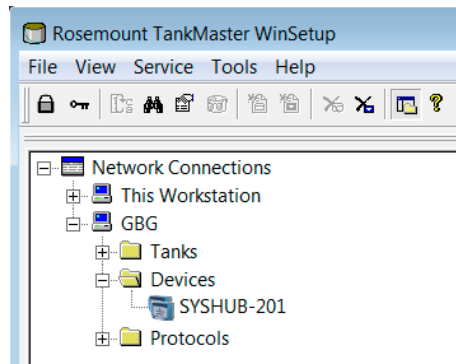

Now the system hub will be able to communicate with the host system and collect data from the field devices.

#### Postrequisites

Proceed with installation and configuration of Rosemount 2410 Tank Hubs and field devices. See the Rosemount Tank Gauging [System Configuration Manual](#) (Document No. 00809-0300-5100) for more information.

### 4.3.4

## Tank databases of the Rosemount 2460 and the Rosemount 2410

In a typical Rosemount Tank Gauging system, a Rosemount 2460 System Hub collects measurement data from a number of tanks via one or more Rosemount 2410 Tank Hubs. For proper communication with the control room PC and the Rosemount TankMaster operator's interface, Modbus addresses need to be assigned to the field devices on the tank. These addresses are stored in the system hub's and tank hub's tank databases.

In the tank hub's database, the Rosemount 2240S Temperature Transmitter and the Rosemount 2230 Graphical Field Display (and other non-level devices) are handled as a single **Auxiliary Tank Device (ATD)**. Two Modbus addresses are used for each tank, one for the level gauge and one for the ATD.

The ATD includes any supported non-level device such as the Rosemount 2240S Multi-Input Temperature Transmitter and the Rosemount 2230 Graphical Field Display. Other devices such as the Rosemount 3051S Pressure Transmitter may also be included in the ATD. The ATD address represents all these devices. Each position in the Rosemount 2460 tank database represents one tank.

In case the level gauge is a Rosemount 5900S 2-in-1, you will need to configure two level device addresses for the Rosemount 5900S gauge. See the Rosemount Tank Gauging [System Configuration Manual](#) (Document No. 00809-0300-5100) for a detailed description of how to configure the tank database with a Rosemount 5900S 2-in-1.

### One Rosemount 2410 Tank Hub for each tank

In this example a Rosemount 2460 System Hub is connected to two tanks, each of which has a separate Rosemount 2410 Tank Hub.

Each tank has a Rosemount 5900S Radar Level Gauge, a Rosemount 2240S Multi-Input Temperature Transmitter, and a Rosemount 2230 Graphical Field Display. The Modbus address configuration is summarized in [Table 4-15](#).

**Table 4-15: Example of Modbus Address Configuration for Rosemount 2410 Tank Hubs and Connected Devices on Two Tanks**

Tank	Rosemount 2410 Tank Hub	Rosemount 5900S Level Gauge	ATD (2230, 2240S)
	Modbus Address		
TK-1	101	1	101
TK-2	102	2	102

For each tank, the Level Device address and ATD Modbus address in the Rosemount 2460 System Hub's tank database must be equal to the corresponding addresses in the Rosemount 2410 Tank Hub's tank database.

**Figure 4-5: Two Tanks Each of which Equipped with a Rosemount 2410 Tank Hub**

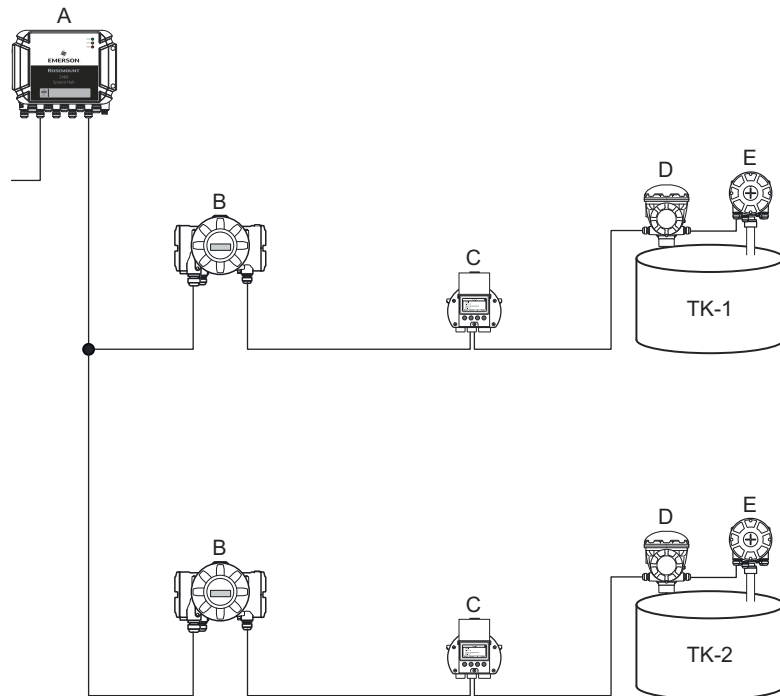

- A. Rosemount 2460 System Hub
- B. Rosemount 2410 Tank Hub
- C. Rosemount 2230 Graphical Field Display
- D. Rosemount 5900S Level Gauge
- E. Rosemount 2240S Temperature Transmitter

**Figure 4-6: Tank Databases in System Hub and Tank Hubs**

A

Device Type	Device ID	Device connected to field bus	Tank Position	Tank Position	Tank Name	Level Modbus Address	ATD Modbus Address
1 5900 RLG	51236	Yes	1	1	TK-1	1	101
2 2240 TTM	1337	Yes	1	2			
3 2230 GFD	1829	Yes	1	3			

B

2460 Tank	Source	Field Port	2410 Device Address	2410 Tank Pos	Level Device Address	Temp Device Address	Number of Temp Elements
1	2410	1	101	1	1	101	6
2	2410	1	102	1	2	102	8

C

Device Type	Device ID	Device connected to field bus	Tank Position	Tank Position	Tank Name	Level Modbus Address	ATD Modbus Address
1 5900 RLG	10097	Yes	1	1	TK-2	2	102
2 2240 TTM	50481	Yes	1	2			
3 2230 GFD	29912	Yes	1	3			

- A. Rosemount 2410 Tank Hub on tank TK-1
- B. Rosemount 2460 System Hub
- C. Rosemount 2410 Tank Hub on tank TK-2

### Multiple tanks connected to a single Rosemount 2410 Tank Hub

In this example a Rosemount 2460 System Hub is connected to a Rosemount 2410 Tank Hub that serves three tanks. The temperature device on tank 1 has the same Modbus address as the tank hub itself. The other temperature devices on tank 2 and 3 have separate Modbus addresses.

Figure 4-7 shows an example of a system with a Rosemount 2460 System Hub connected to a Rosemount 2410 Tank Hub. The Rosemount 2410 collects measurement data from three tanks. Each tank is equipped with a Rosemount 5408 Radar Level Transmitter, a Rosemount 2240S Temperature Transmitter, and a Rosemount 2230 Graphical Field Display. The Modbus address configuration is summarized in Table 4-16.

**Table 4-16: Modbus Address Configuration for Tank Hub and Field Devices on Three Tanks**

Tank	Rosemount 2410 Tank Hub	Rosemount 5408 Level Transmitter	ATD (2230, 2240S)
	Modbus Address		
TK-1	101	1	101
TK-2	101	2	102
TK-3	101	3	103

Note that each ATD has its own Modbus address. Only the first one has the same address as the Rosemount 2410 Tank Hub.

**Figure 4-7: Three Tanks Connected to a Single Rosemount 2410 Tank Hub**

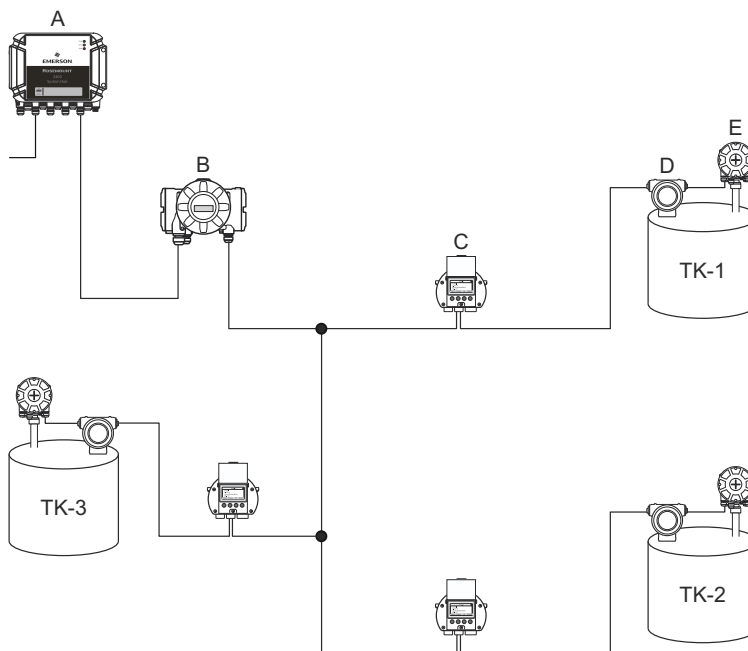

- A. Rosemount 2460 System Hub
- B. Rosemount 2410 Tank Hub
- C. Rosemount 2230 Graphical Field Display
- D. Rosemount 5408 Level Transmitter
- E. Rosemount 2240S Temperature Transmitter

In the tank database of the Rosemount 2410 Tank hub, the Rosemount 2240S temperature transmitter and the Rosemount 2230 display are grouped into an Auxiliary Tank Device (ATD). The **ATD Modbus** address has to be stored in the **Temperature Device** address field in the tank database of the Rosemount 2460 System Hub as illustrated in Figure 4-8. The Modbus addresses of the level devices must also be stored in both the 2410 and the 2460 tank databases.

**Figure 4-8: Tank Databases in System Hub and Tank Hubs**

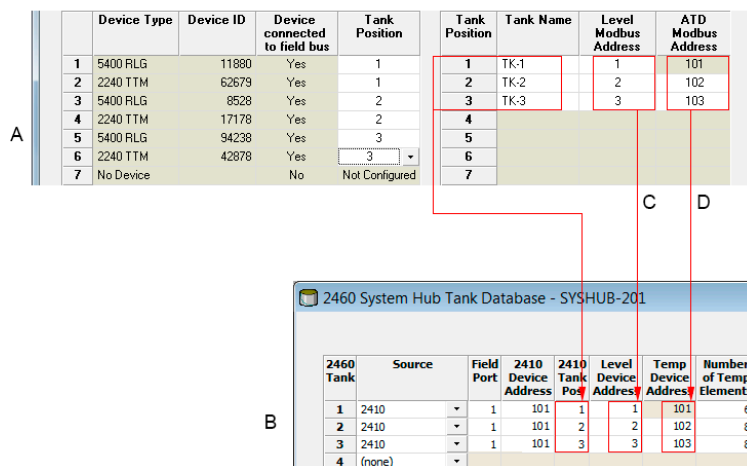

- A. Tank Database for a Rosemount 2410 Tank Hub that serves three tanks
- B. Rosemount 2460 System Hub
- C. Level device address
- D. Auxiliary Tank Device (ATD) address

Note that in this example a single Rosemount 2410 Tank Hub serves three tanks. The tanks are mapped to tank position 1, 2, and 3 in the Rosemount 2410 Tank Hub's tank database.

In the tank database of the Rosemount 2460 System Hub, you will have to configure **2410 Tank Position** in order to be able to configure the correct Temperature Device Addresses for the three tanks.



## 4.3.5 System setup

The **System Values** window lets you specify parameters and units for inventory calculations.

### Procedure

1. Log in to the Web interface.
2. Select **Configuration** → **System Values**.

Figure 4-9: System Parameters and Units

The screenshot displays the 'System Values Configuration' page. On the left is a navigation sidebar with the Emerson logo and various menu items. The main content area is divided into sections: 'Manual values' with checkboxes for 'Manual air temperature' and 'Manual air pressure', and input fields for 'Ambient air temperature' (15.0 °C), 'Ambient air pressure' (1.01325 bar (A)), and 'Reference temperature' (0.0 °C). Below this is the 'System units' section with dropdown menus for 'Level unit' (m), 'Level rate unit' (m/h), 'Temperature unit' (Celsius), 'Pressure unit' (bar (G)), 'Density unit' (kg/m3), 'Volume unit' (m3), 'Weight unit' (Ton (m)), and 'Flow rate unit' (m3/h). The 'Display options' section includes a 'Feet value' dropdown set to 'ft in \* 1/16in'. An 'Apply' button is located at the bottom of the configuration area. The footer contains copyright information: 'Copyright © 2015-2020 Rosemount Tank Radar AB | 2460 System Hub Open Source Software Licenses | FW ver. 1.K0 - 10731'.

### Related information

[Logging in to the web interface](#)

### Manual values

Select the appropriate check boxes in case you like to use manual values for ambient air temperature and pressure, and type the desired values into the input fields.

### Reference temperature

The Rosemount 2460 System Hub performs inventory calculations according to the *API Manual of Petroleum Measurement Standards Chapter 12, Section 1*, at the standard reference temperature 15°C (60°F). This is the default reference temperature.

Other reference temperatures can be specified in the **Reference Temperature** input field. Ensure that correct RT volume table, for example 54B-2004, is used for the product.

## System units

Level, Level Rate, Temperature, and Pressure units are configured in TankMaster WinSetup configuration program.

## Display options for Feet unit

In case **Feet** is selected as measurement unit for **Level**, the **Feet Display** option lets you choose the desired display option. You may choose to present as decimal or fraction: ft' in" 1/16 in.

## 4.3.6 Redundancy configuration

Setting up a redundant pair of Rosemount 2460 System Hubs can be performed by using TankMaster WinSetup or the system hub's Web Graphical User Interface.

### Related information

[Redundancy setup in TankMaster WinSetup](#)

[Redundancy setup via Web graphical user interface](#)

### Preconditions for redundancy setup

The following conditions must be met to allow setting up two Rosemount 2460 System Hubs for redundancy operation:

- The same firmware version on both System Hubs
- Firmware version 1.C0 or higher
- Rosemount TankMaster version 6.D0 or higher
- For Modbus TCP; Rosemount TankMaster version 6.F0 or higher
- No warnings or errors
- License;
  - the same maximum number of tanks
  - redundancy option enabled on both system hubs
  - the same number of Modbus TCP clients
- The same modem board setup<sup>(7)</sup> (number of boards, modem type, and modem locations)
- Hardware write protection disabled
- Software write protection disabled

Basically all model codes except **Housing**, **Cable/Conduit Connections**, and **Options** need to be identical for the Primary and Backup system hubs.

---

(7) Modem boards supported for redundancy: TRL2 Modbus, RS485, Enraf BPM

## System Architecture with redundant system hubs

Figure 4-10: Rosemount Tank Gauging System Architecture with Redundant System Hubs

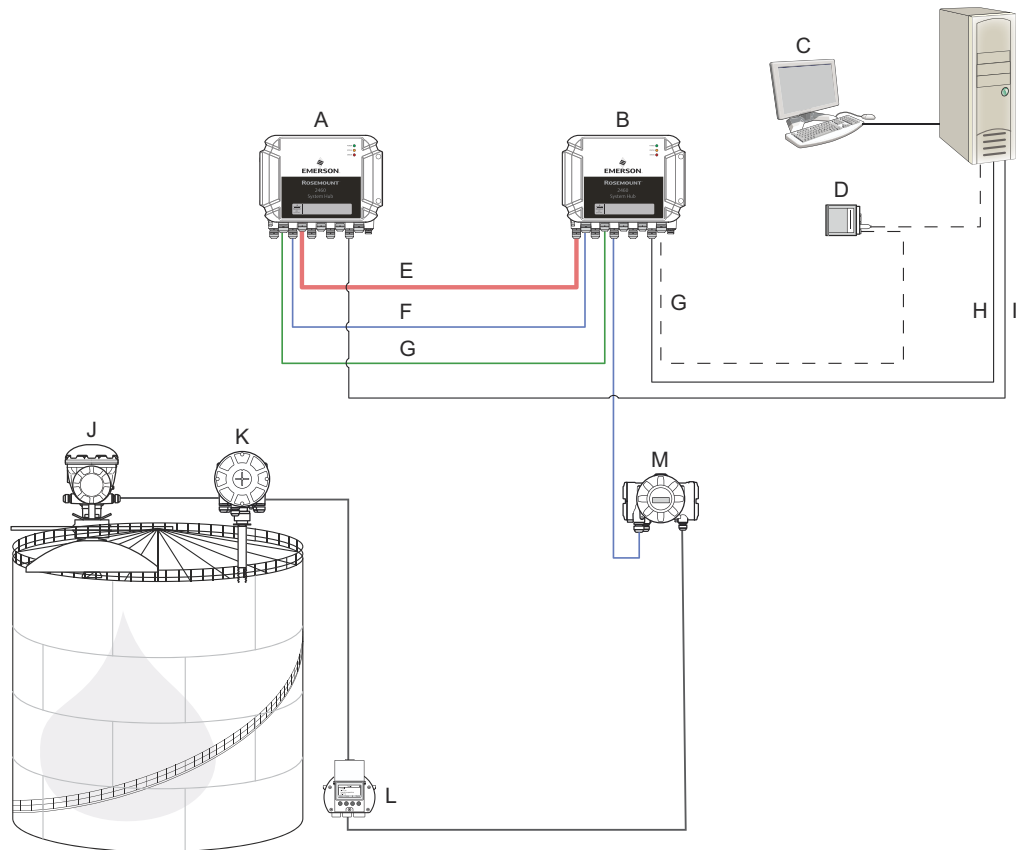

- |    |                                     |    |   |
|----|-------------------------------------|----|---|
| A. | Rosemount 2460 System Hub (backup)  | H. | Modbus TCP (Primary)                    |
| B. | Rosemount 2460 System Hub (primary) | I. | Modbus TCP (Backup)                     |
| C. | Host System                         | J. | Rosemount 5900S Radar Level Gauge       |
| D. | Modem                               | K. | Rosemount 2240S Temperature Transmitter |
| E. | Redundancy cable                    | L. | Rosemount 2230 Display                  |
| F. | Field Ports                         | M. | Rosemount 2410 Tank Hub                 |
| G. | Host Ports                          |    |   |

## Redundancy setup in TankMaster WinSetup

This section describes the redundancy setup in the WinSetup configuration wizard for the Rosemount 2460 System Hub.

### Prerequisites

The installation wizard for the Rosemount 2460 includes the option to setup a redundant pair of Rosemount 2460 System Hubs as long as certain conditions are fulfilled. In case

all requirements for pairing are fulfilled, the following text appears: "Pairing is possible, Backup device ID:xx".

**Figure 4-11: Redundancy Page in WinSetup Installation Wizard**

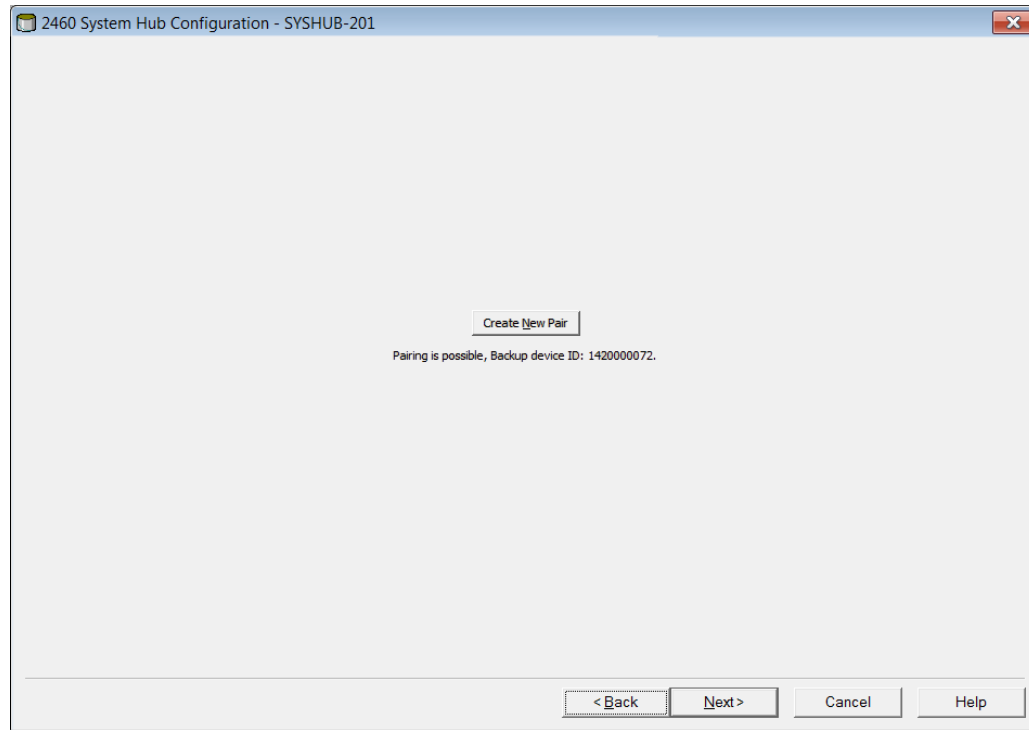

### Procedure

Click the **Create New Pair** button to start the redundancy synchronization procedure.

**Figure 4-12: Redundancy Pairing**

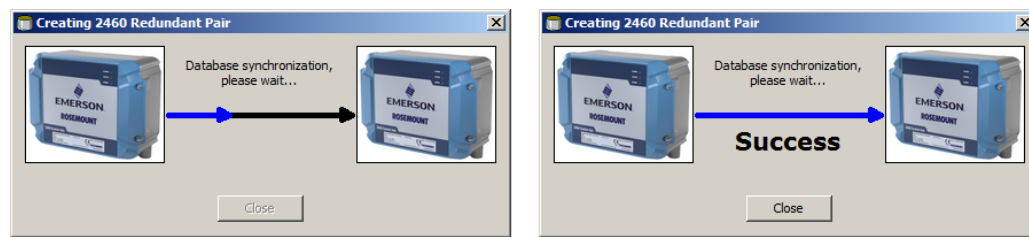

When finished, a message appears that the database synchronization was successfully completed. The system hubs will be paired as a Primary and a Backup device.

### Redundancy window

Once the synchronization process is successfully finished, the **Redundancy** window presents the current status and other information for the two system hubs.

Figure 4-13: Redundant System Hubs

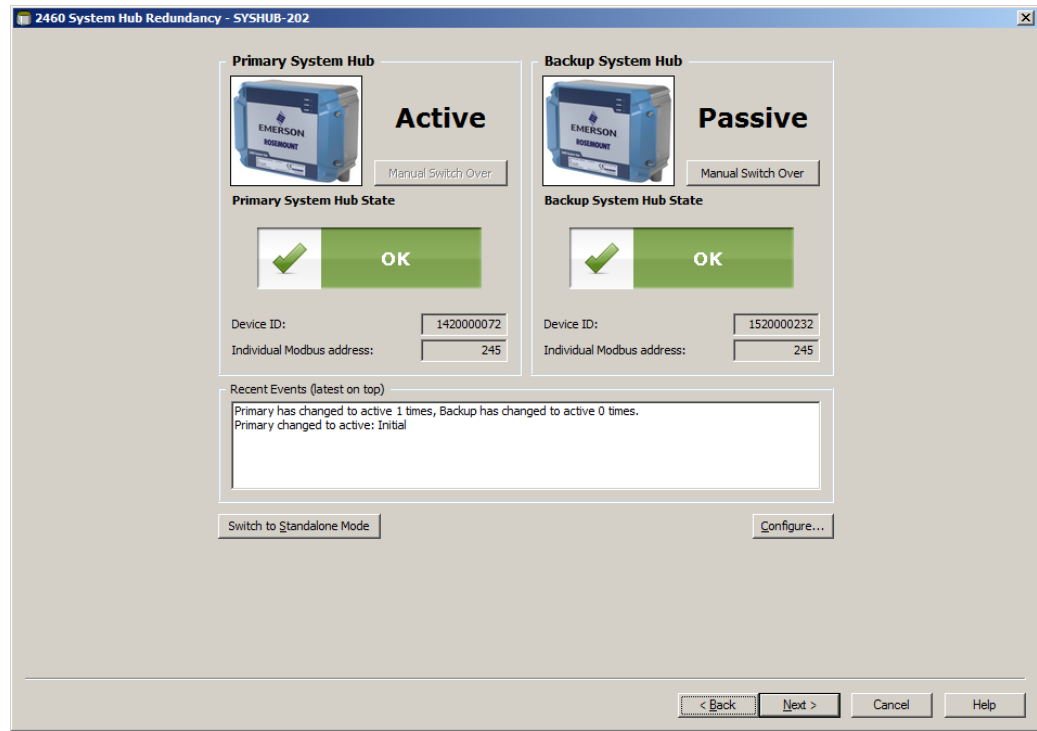

**Table 4-17: Redundancy Configuration**

Item	Description
Manual Switch Over button	Active/Passive mode can be changed manually. The Active device communicates with the host system and responds to requests for measurement data, status information, and diagnostics. This option can be useful for testing that both system hubs function properly as Active and Passive.
State	If the status is OK, a green check box is displayed. Otherwise a list of warnings and errors will be displayed.
Device ID	Each device has a unique identification number which can be used, for example, when setting up Modbus addresses.
Individual Modbus address	The redundant system hubs can be given individual Modbus addresses in case you need to be able to communicate separately with each system hub.
Recent events	Number of times that the Primary and Backup devices have changed to active state, as well various error messages and warnings.
Switch to standalone mode button	It is possible to un-pair the two devices in the redundancy system by using the Switch to Standalone Mode button. When un-pairing the system, the active device will change mode to standalone. The passive device will load the default configuration database (CDB) and the default communication parameters (including Modbus address 245) to make sure it will not disturb communication on Host and Field ports after un-pairing the system hubs. Consequently, the host system will lose contact with the backup device until proper communication settings are reset.
Configure button	This button lets you configure specific redundancy options such as fail-over, take-over, and passive device communication.

### Configure button

You may configure various options for fail-over and other redundancy related issues. You may also set separate Modbus addresses for the two system hubs.

#### Procedure

In the **System Hub Redundancy** window, click the **Configure** button to open the **2460 System Hub Redundancy Configuration** window.

#### Related information

[System hub redundancy configuration window](#)

## System hub redundancy configuration window

Figure 4-14: System Hub Redundancy Configuration

**2460 System Hub Redundancy Configuration**

**Primary System Hub** **Active**

Device ID: 142000011  
Individual Modbus address: 241

**Backup System Hub** **Passive**

Device ID: 152000052  
Individual Modbus address: 242

**Fail-over Criteria**

Configuration file error  
 Host port modem error  
 Field port modem error  
 Field port communication failure on...

port 1  port 2  port 3  port 4  
 port 5  port 6 **All ports**

Maximum number of Fail-overs per hour (1..10): 2

**Take-over Criteria**

Active doesn't reply on Host port

**Minimum Polling Interval**

Host Port 5: 10    Host Port 7: 10    Modbus/TCP: 10  
 Host Port 6: 10    Host Port 8: 10

**Passive Device Communication**

Allow Passive device to reply on common Modbus address

OK    Cancel    Help

### Individual Modbus address

By setting individual Modbus addresses for the Primary and Backup devices, a host system may communicate with each device separately. This is useful, for example, for verifying the current status of each device.

### Minimum Polling Interval

If the host system uses a longer poll interval in the communication than the configured value, the system will report error.

Entry fields for Host Ports 5 and 6 will only be enabled if the ports are configured as host ports. Entry fields for Modbus TCP will only be enabled if Modbus TCP license option is enabled.



## Fail-over criteria

**Table 4-18: Fail-over Criteria**

Criteria	Description
Configuration file error (default)	Configuration database (CDB) is corrupt.
Host port modem error (default)	A Host port modem has failed or been removed.
Field port modem error (default)	A Field port modem has failed or been removed.
Field port communication failure	No response from any field device on a Field port. This option is most useful for redundant field bus wiring where each Rosemount 2460 has separate field bus wiring.
Field port communication failure on...	Individual port configuration for Field Port communication failure.
Maximum number of Fail-overs per hour (1..10)	Maximum number of fail-overs per hour in order to prevent an oscillating behavior i.e. switching back and forth between Primary and Backup device. In case fail-overs tend to occur frequently, the reason behind should be investigated and fixed.

## Take-over criteria

There may be situations when you would like the passive device to take over as the active device even if no fail-over criteria is fulfilled. For example, in case the active device does not respond to Host requests, the passive device may take over and become the active device. The **Active doesn't reply on Host port** option does not work if the Primary and Backup system hubs are wired to separate host ports which is the case when, for example, using the RS232 communication interface.

## Passive device communication

In case the Primary and Backup system hubs are connected to different ports on the host system, the same Modbus address can be used for communication with the two system hubs. Then there is no need to use individual Modbus addresses for the Primary and Backup devices. When communicating with a host system via RS232 interface, separate host ports must be used, and the **Allow Passive device to reply on common Modbus address** option needs to be enabled.

## Finish the installation wizard

Once the redundancy configuration is finished:

### Procedure

In the **2460 System Hub Redundancy** window, click the **Next** button.

### Postrequisites

Proceed with [Step 6. Finish the installation](#) to finish the installation wizard.

## Redundancy setup via Web graphical user interface

This section describes how to use the the Web graphical interface for redundancy setup of a Rosemount 2460 System Hub. The setup includes two basic steps:

- Pairing; two system hubs are setup as a redundant pair
- Redundancy configuration; addresses and fail-over criteria are configured

### Pairing

#### Prerequisites

For the system hubs to be able to pair, ensure that the preconditions are fulfilled.

#### Procedure

1. Log in to the Web interface.
2. Select the **Redundancy** tab.
3. Expand the **Pair** option.
4. Verify that the other system hub is pairable, i.e. all requirements for pairing are marked with a green button.

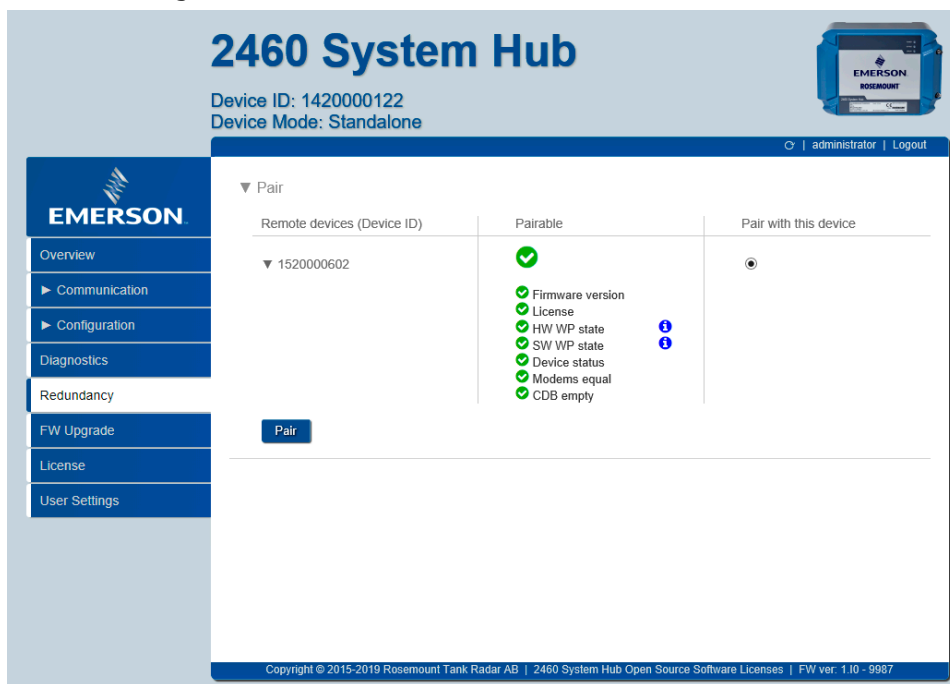

5. If the two system hubs (Primary and Backup) are ready for pairing, click the **Pair** button to start the synchronization process.

#### Related information

[Using the web interface](#)

[Preconditions for redundancy setup](#)

## Redundancy configuration procedure

Once the synchronization is finished you may configure the system hubs for redundancy operation.

### Procedure

1. In the Web interface, select the **Redundancy** tab.

2. Expand the **Configuration** option.

▼ Configuration

Common Modbus Address: 231

Specific Modbus Address for Primary Device:  [1-245]

Specific Modbus Address for Backup Device:  [1-245]

Passive Device responds on common address:  ⓘ

Max Fail-Overs per Hour:  [1-10]

Fail-over criteria	On	Off
Configuration file error	<input checked="" type="radio"/>	<input type="radio"/>
Field port modem error	<input checked="" type="radio"/>	<input type="radio"/>
Field port communication failure	<input type="radio"/>	<input checked="" type="radio"/>
Host port modem error	<input checked="" type="radio"/>	<input type="radio"/>
Take-over criteria	On	Off
Active doesn't reply on host port	<input type="radio"/>	<input checked="" type="radio"/>
Modbus TCP host communication	On	Off
Use Modbus TCP as main host interface	<input checked="" type="radio"/>	<input type="radio"/>

Apply ⓘ

► Unpair

3. Configure the device.

**Example**

Fail-over criteria	On	Off
Configuration file error	<input checked="" type="radio"/>	<input type="radio"/>
Field port modem error	<input checked="" type="radio"/>	<input type="radio"/>
Field port communication failure	<input checked="" type="radio"/>	<input type="radio"/>
Field port 1	<input checked="" type="radio"/>	<input type="radio"/>
Field port 2	<input checked="" type="radio"/>	<input type="radio"/>
Field port 3	<input checked="" type="radio"/>	<input type="radio"/>
Field port 4	<input checked="" type="radio"/>	<input type="radio"/>
Field port 5	<input checked="" type="radio"/>	<input type="radio"/>

**Related information**

[Redundancy configuration overview](#)

**Redundancy configuration overview**

**Table 4-19: Redundancy Configuration Overview**

Item	Description
Primary Device ID Backup Device ID	Each device has a unique identification number.
Redundancy status	If status is OK, a green check box is displayed. You may expand the Status list to view further details. In case status is not OK, a list of warnings and errors will be displayed.
Manual switch over	Active/Passive mode can be changed manually. The Active device communicates with the host system and responds to requests for measurement data, status information, and diagnostics. This option can be useful for testing that both system hubs function properly as Active and Passive.
Configuration	See <a href="#">Table 4-20</a> .
Unpair	It is possible to un-pair the two devices in the redundancy system. When un-pairing the redundant system hubs, the active device will change mode to standalone. The passive device will load the default configuration database and the default Modbus address (245) to make sure it will not disturb communication on Host and Field ports after unpairing the system hubs.

**Table 4-20: Redundancy Configuration Options**

Item	Description
Common Modbus Address	Common Modbus address is the standard setting. Primary and Backup system hubs use the same Modbus address. You may use this option in case Primary and Backup system hubs are connected to different host ports. Then the same Modbus address can be used instead of individual addresses.
Specific Modbus Address for Primary Device / Specific Modbus Address for Backup Device	The redundant system hubs can be given individual Modbus addresses in case you need to be able to communicate separately with each system hub. This is useful, for example, for verifying the current status of each device.
Passive device responds on common address	In case the Primary and Backup system hubs are connected to different ports on the host system, the same Modbus address can be used for communication with the two system hubs. Then there is no need to use individual Modbus addresses for the Primary and Backup devices. When communicating with a host system via RS232 interface, separate host ports must be used, and the <b>Allow Passive device to reply on common Modbus address</b> option needs to be enabled.
Max Fail-Overs per Hour	Maximum number of fail-overs per hour in order to prevent an oscillating behavior i.e. switching back and forth between Primary and Backup device. In case fail-overs tend to occur frequently, the reason behind should be investigated and fixed.
Fail-over criteria	Criteria for primary device failure that will make the backup device to take over.
Take-over criteria	Criteria that will make the backup device to take over even in case there is no primary device failure.
Use Modbus TCP as main host interface	If Modbus TCP is used for communication with the host system and no Host Ports are used, it is necessary to enable this function. If not set the passive system hub will not take over as active device when the active is powered off or fails.

**Related information**

[View redundancy state in TankMaster WinSetup System hub redundancy configuration window](#)

## 4.4 Inventory calculation configuration

The **Inventory** function lets you set up a tank for volume calculations based on appropriate API tables.

Ensure that system parameters and units are configured prior to configuring inventory calculations.

The **Help** button opens a volume calculation flow chart that illustrates input parameters for the various inventory calculations.

Figure 4-15: Inventory Calculation Configuration

The screenshot shows the 'Inventory Configuration' page in a web browser. The left sidebar contains a navigation menu with the following items: Overview, View, Communication, Configuration (expanded), Time, Parts, Network, Modbus TCP, User Defined Server, User Defined Device, Database, System Values, Manual Values, Inventory (selected), Strapping Table, Tank Name, Diagnostics, Redundancy, Maintenance, License, Simulation, and User Settings. The main content area is titled 'Inventory Configuration' and includes the following sections:

- Load current configuration:** A checked checkbox.
- Tank:** A dropdown menu showing 'TK-1'.
- Tank Capacity:** Includes 'Tank type' (Sphere LPG), 'Vapor above max volume' (0.000 barrels), 'Max volume' (100000.000 barrels), 'Min volume' (0.000 barrels), and 'Sump volume' (0.000 barrels).
- Tank Shell:** Includes 'Type' (Not insulated), 'Linear expansion coefficient' (0.0000  $10^{-6}/^{\circ}F$ ), and 'Reference temperature' (0.0  $^{\circ}F$ ).
- Floating Roof Correction:** Includes 'Upper limit' (0'0" ft.), 'Lower limit' (0'0" ft.), 'Weight' (0.000 ton (s)), 'Roof correction in TCT' (unchecked), 'Base density' (0.0000 @ 60/60  $^{\circ}F$ ), and 'Volume adjustment' (0.000 barrels).
- LPG:** Includes 'Calculate LPG mass in air' (unchecked), 'Molecular mass' (0.000000 g/mol), 'Compressibility factor' (1.000000), and 'Vapor to liquid volume ratio' (0.000).
- Net Calculation:** Includes 'Volume correction table' (RT 54B (2004)), 'Use observed density input' (unchecked), 'Reference density' (850.0000 @ 60/60  $^{\circ}F$ ), 'Thermal exp. coeff.' (0.0000  $10^{-6}/^{\circ}F$ ), 'Sediment & water' (0.000 %), 'Product reference temperature' (0.0  $^{\circ}F$ ), and 'Product density correction' (850.0000 @ 60/60  $^{\circ}F$ ).

Labels A through F are positioned to the right of the interface, pointing to the following sections:

- A: Load current configuration
- B: Tank Capacity
- C: Tank Shell
- D: Floating Roof Correction
- E: LPG
- F: Net Calculation

- A. Load current configuration
- B. Tank Capacity
- C. Tank Shell
- D. Floating roof correction
- E. LPG
- F. Net calculation

**Table 4-21: Inventory Configuration**

Item	Description
Load current configuration	Select this option in case you want to load the current inventory configuration to the tank selected in the drop-down list "Tank no.". You may also use this function to copy a configuration from one tank to the other.
<b>Tank Capacity</b>	
Tank type	Select the tank type that is most suitable for your tank. You may choose one of the predefined types: <ul style="list-style-type: none"> <li>• Cylinder</li> <li>• Floating roof</li> <li>• Horizontal LPG</li> <li>• Sphere LPG.</li> </ul>
Type	Select the desired type of strapping table and calculation method: <ul style="list-style-type: none"> <li>• Raw</li> <li>• Northern (relative levels; mostly used in Sweden and Finland)</li> <li>• International (absolute levels)</li> </ul>
Size	Number of strapping points in the Tank Capacity Table. This value is automatically updated when uploading a TCT in CSV format.
Vapor above max. volume	Vapor volume above the Max. Volume limit. This is used for LPG tanks only.
Maximum volume	The maximum volume that can be stored in the tank.
Minimum volume	This is the volume between the tank outlet and the bottom of the tank.
Sump volume	This is the volume that is left when the tank is emptied down to Zero level. As an alternative the Sump volume can be included in the Tank Capacity Table. In this case the base volume at the Zero level is equal to the sump volume. Ensure that the sump volume is not specified both ways simultaneously.
<b>Tank Shell</b>	
Type	Specify if the tank is insulated or not. For an insulated tank the ambient temperature does not have any influence on shell correction calculations.
Linear expansion coefficient	The Linear Expansion Coefficient is used in calculations of Gross Observed Volume (GOV) in order to correct for the thermal expansion of the tank wall. The default value, 0.0000112/°C, is used for mild carbon steel.
Reference temperature	This is the temperature at which the Tank Capacity Table is specified. Temperatures other than the Reference Temperature are taken into account and compensated for when performing volume calculations.



**Table 4-21: Inventory Configuration (continued)**

Item	Description
<b>Floating roof correction</b>	
Upper limit	Above Upper limit the roof is fully floating and full compensation is made for volume reduction.
Lower limit	Below the Lower limit when the roof rests on its legs no compensation of volume is made. Between Upper and Lower limit compensation is made through a weighted value.
Weight	Volume compensation depends on roof weight and roof position.
Roof correction in TCT	If the roof correction is included in the Tank Capacity Table using a Base density, a secondary correction will be calculated by the system hub. The secondary correction will be based on the observed density, base density, and volume adjustment.
Base density	This is the density at which the tank capacity table was specified. This value can be found in the tank capacity table (tank certificate).
Volume adjustment	Volume adjustment from the tank capacity table (tank certificate).
<b>LPG</b>	
Calculate LPG mass in air	Check this option to calculate as mass in air. In the default setting, LPG vapor mass and product mass will be calculated as mass in vacuum.
Molecular mass	Molecular mass of the product is used in calculation of vapor mass.
Compressibility factor	The compressibility factor is used in converting vapor volume to the corresponding volume at standard temperature and pressure.
Vapor to liquid volume ratio	For LPG products Vapor Volume Liquid Ratio (VLVR) is used for converting vapor volume to liquid volume. This is used in calculations of Net Standard Volume (NSV).

**Table 4-22: Inventory Configuration Net Calculation**

Item	Description
<b>Net calculation</b>	
Volume correction table	Reference Density and Average Temperature are used for calculating <b>CTPL</b> <sup>(1)</sup> according to the API standard. Select a API/ASTM volume correction table based on the product: <ul style="list-style-type: none"> <li>• A tables for crude oil</li> <li>• B tables for refined products</li> <li>• C tables for special applications</li> <li>• D tables for lubricating oil</li> <li>• E tables for LPG and NGL</li> <li>• D4311 table for asphalt</li> <li>• Ethanol NBR 5992</li> <li>• Linear</li> </ul>
Use observed density input	Select this check box in case you want to use observed density from field device as input for calculating reference density. In the default setting a manual value is used for the reference density.
Reference density	Enter a manual Reference density value to be used for CTPL <sup>(1)</sup> calculation according to API standard in case observed density is not used.
Thermal expansion coefficient	The <b>Thermal Expansion Coefficient</b> (TEC Liquid) is required as input for some volume correction tables.
Sediment and water	<b>Sediment and water</b> is subtracted from Gross Standard Volume to calculate the Net Standard Volume.
Product reference temperature	Manual product reference temperature is used in CTPL <sup>(1)</sup> calculations with <b>Linear</b> volume correction tables.
Product density correction	Manual density correction per 1 degree. Used with <b>Linear</b> volume correction tables.

(1) CTPL=Correction for Temperature and Pressure of the Liquid

**Related information**

[System setup](#)

[Copying inventory configuration from one tank to another](#)

## 4.4.1 Copying inventory configuration from one tank to another

### Procedure

1. In the **Tank No.** drop-down list select the desired tank number.
2. Configure manual values.
3. Deselect **Load current configuration**.
4. Select a new tank number in the **Tank No.** drop-down list.
5. Select the **Load current configuration** check box.
6. Click **Apply**.

## 4.4.2 Inventory manual values

The **Inventory Manual Values Configuration** window lets you specify manual values for a number of inventory parameters.

### Note

Manual values override measurement values from field devices.

Figure 4-16: Inventory Manual Values Window

Table 4-23: Manual Values Configuration

Item	Description
Load current configuration	Select this option in case you want to load the current inventory configuration to the tank selected in the drop-down list <b>Tank no.</b> . You may also use this function to copy a configuration from one tank to the other.
Use manual values for	Select the parameters for which you will use manual values. Type the desired values in the corresponding input fields.

### Related information

[Copying manual values configuration from one tank to another](#)

### 4.4.3 Copying manual values configuration from one tank to another

#### Procedure

1. In the **Tank No.** drop-down list select the desired tank number.
2. Configure manual values.
3. De-select **Load current configuration**.
4. Select a new tank number in the **Tank No.** drop-down list.
5. Select the **Load current configuration** check box.
6. Click **Apply**.

## 4.5 Strapping table configuration

This option lets you create a strapping table of up to 5000 points for product volume calculations. See [Table 4-24](#) for more information.

Figure 4-17: Strapping Table

The screenshot shows the 'Strapping Table Configuration' page. At the top, there's a 'Load current configuration' checkbox which is checked (labeled A). Below it is a 'Tank' dropdown menu set to 'TK-1' (labeled B). The 'Table type' is set to 'Raw' (labeled C). The 'Table size' is '1395' with a range of '[ 0 - 5000 ]' and a note '(Current TCT table size > 60)' (labeled D). Below these are 'Strapping Points' with columns for '#', 'Level from (m)', 'Base volume (m³)', and 'Area coeff. (m³/m)'. The table contains 22 rows of data (labeled E). At the bottom, there's a section for 'Upload TCT Table as CSV file' with a 'Strapping table template:' dropdown and a 'Download' button (labeled F), and a 'File upload:' section with a 'Valj fil' button and the text 'Ingen fil har valts'. An 'Apply' button is at the bottom left. The footer contains copyright information: 'Copyright © 2015-2020 Rosemount Tank Radar AB | 2460 System Hub Open Source Software Licenses | FW ver. 1.K0 - 10731'.

- A. Load current configuration
- B. Tank number
- C. Table type
- D. Table size
- E. Strapping points
- F. Download/upload Excel CSV template file for strapping table (TCT). For more than 60 strapping points.

Use the drop-down list to select which tank to configure. The fields are updated dynamically when a new tank is selected. You may disable updating the fields by unchecking the **Load current configuration** check box.

Loading the configuration from one tank, un-checking the **Load current configuration** check box, and then selecting a new tank is a fast way to copy configuration from one tank to another.

To configure more than 60 strapping points, you will have to use the strapping table template in CSV format. It may be downloaded by pressing the **Download** button.

Once the strapping table file is edited, it may be uploaded to the system hub by using the **File upload** function.

**Table 4-24: Strapping Table Configuration**

<b>Tank</b>	
Load current configuration	This option enables loading the strapping table for the currently selected tank number.
Tank no.	Selected tank.
<b>Strapping Table</b>	
Table type	You may select one of the following types: International, Northern, or Raw.
Table size	A maximum of 5000 points can be added. The number of strapping points is automatically updated from the existing configuration.
Strapping points	You may manually enter up to 60 points. To configure more strapping points, you will have to use the strapping table template in CSV format.
<b>Upload TCT Table as CSV file</b>	
Strapping table template	You may download a template file in standard CSV format. The CSV file can be used to create a strapping table by editing in Microsoft® Excel or a similar application.
File upload	A TCT can be created by uploading a CSV file with strapping points.
	<b>Note</b> Existing points will be replaced.
	<b>Note</b> The CSV file must use "." as decimal separator.

## 4.6 Floating roof monitoring

This is a brief description on how to enable and configure the **Floating Roof Monitoring** function in the Rosemount 2460 System Hub.

The **Floating Roof Monitoring** function in Rosemount 2460 System Hub can detect whether a roof in a storage tank is stuck, sinking, floating higher or lower than normal, or is tilted.

The **Floating Roof Monitoring** function includes:

- Roof tilt detection
- Bouyancy calculations
- Status alerts

You need to implement a Modbus server polling the Floating Roof Monitoring **input registers** and act on alerts. The **Floating Roof Monitoring** functionality in Rosemount 2460 System Hub requires **license** option.

### Related information

[Rosemount TankMaster Floating Roof Monitoring Manual](#)

[Configuration overview](#)

[Floating roof monitoring input register area](#)

[Using the web interface](#)

[License upgrade](#)

### 4.6.1 Preparations

Prior to configuring the tank for floating roof monitoring, you will need to install and configure all devices.

#### Procedure

1. Install **tilt** gauges, **level reference** gauge, and other devices that will be used on the tank.
2. Wire the devices.
3. Verify proper communication for all devices.
4. Configure the devices as normal, preferably by using the Rosemount TankMaster WinSetup configuration software.

---

#### Note

Tilt gauges should not be associated with a tank at this stage. That is part of the floating roof monitoring setup.

---

5. Ensure that the tank databases of the Rosemount 2410 and Rosemount 2460 are properly configured for all devices.
6. Configure the tank for floating roof monitoring.

#### Related information

[Configuration overview](#)

[Floating roof monitoring configuration](#)



## 4.6.2 Configuration overview

In the Rosemount 2460's web based user interface, you will find Floating Roof Monitoring setup in the **Configuration** menu.

The setup includes:

- Enable Floating Roof Monitoring
- Select tank
- Select the instruments
- Alert limit setup

**Figure 4-18: Floating roof monitoring configuration**

Floating Roof Monitoring Configuration

---

Tank: TK-101A ▼

---

Floating Roof Monitoring:  Enable i

---

Monitoring Instruments

Mounting Type:  Shell-Mounted With Level Reference  
 Shell-Mounted Without Level Reference

	Source	Field Port	2410 Device Address	2410 Tank Pos	Level Address	Input
Tilt Gauge 1:	<span style="border: 1px solid #ccc; padding: 2px;">2410</span> <span style="float: right;">▼</span>	<span style="border: 1px solid #ccc; padding: 2px;">1</span> <span style="float: right;">▼</span>	<span style="border: 1px solid #ccc; padding: 2px;">130</span>	<span style="border: 1px solid #ccc; padding: 2px;">2</span> <span style="float: right;">▼</span>	<span style="border: 1px solid #ccc; padding: 2px;">12</span>	<span style="border: 1px solid #ccc; padding: 2px;">Ullage</span> <span style="float: right;">▼</span>
Tilt Gauge 2:	<span style="border: 1px solid #ccc; padding: 2px;">2410</span> <span style="float: right;">▼</span>	<span style="border: 1px solid #ccc; padding: 2px;">1</span> <span style="float: right;">▼</span>	<span style="border: 1px solid #ccc; padding: 2px;">130</span>	<span style="border: 1px solid #ccc; padding: 2px;">3</span> <span style="float: right;">▼</span>	<span style="border: 1px solid #ccc; padding: 2px;">13</span>	<span style="border: 1px solid #ccc; padding: 2px;">Ullage</span> <span style="float: right;">▼</span>
Tilt Gauge 3:	<span style="border: 1px solid #ccc; padding: 2px;">2410</span> <span style="float: right;">▼</span>	<span style="border: 1px solid #ccc; padding: 2px;">1</span> <span style="float: right;">▼</span>	<span style="border: 1px solid #ccc; padding: 2px;">130</span>	<span style="border: 1px solid #ccc; padding: 2px;">4</span> <span style="float: right;">▼</span>	<span style="border: 1px solid #ccc; padding: 2px;">14</span>	<span style="border: 1px solid #ccc; padding: 2px;">Ullage</span> <span style="float: right;">▼</span>

---

Roof Tilt Alert Limit

High: 0.200 m i

---

Floating Roof Alert Limits

High: 0.150 m i

Low: -0.150 m i

Calibration offset: 0.532 m i

Roof lower limit: 1.451 m i

---

Apply

### Related information

[Floating roof monitoring configuration Menus in the web user interface](#)

### 4.6.3 Floating roof monitoring configuration

This section describes Floating Roof Monitoring configuration options in the Rosemount 2460 System Hub's web based user interface.

#### Tank

Select the desired tank with tilt gauges to be configured for floating roof monitoring.

#### Enable floating roof monitoring

Enable floating roof monitoring for the selected tank.

#### Monitoring instruments

Select the appropriate **mounting type**:

- Shell mounted with Level Reference
- Shell mounted without Level Reference

Select **Shell mounted with Level Reference** in case the tank has a level reference gauge in addition to the tilt gauges. This means that roof high/low calculations can be performed.

#### Tilt gauge configuration

Configure **tilt gauge parameters**:

**Table 4-25: Tilt gauge configuration**

Tilt gauge parameter	Description
Source	Select the Rosemount 2410 Tank Hub that is installed on the selected tank. The tilt gauges must be configured in the tank hub's tank database, and should be done as part of the tank hub configuration.
Field port	Select the appropriate tank hub field port that the tilt gauge is connected to.
Rosemount 2410 Device Address	Enter the tank hub's Modbus communication address.
Rosemount 2410 tank position	Select the tilt gauge position in the Rosemount 2410 tank database.
Level address	Enter the the tilt gauge Modbus communication address. The gauge must be configured in the tank hub's tank database.
Input	Ullage or User Defined 1 to 5.

#### Roof tilt alert limit

Enter the maximum allowed roof tilt.

#### Floating roof alert limits

Enter the desired alert limits:

**Table 4-26: Floating roof alert limits**

Tilt gauge alert limit	Description
High	Maximum positive floating difference. Roof may be stuck.
Low	Maximum negative floating difference. Roof may be sinking..

**Table 4-26: Floating roof alert limits (continued)**

Tilt gauge alert limit	Description
Calibration offset	<b>Calibration offset</b> is added to all tilt gauges on the tank roof. Use this offset to get a <b>float offset</b> (buoyancy) equal to zero in normal condition when the roof is freely floating and not tilting.
Roof Lower Limit	Threshold for roof resting on legs status indication. Product levels below this value will result in status message <b>Roof Resting On Legs</b>

**Related information**

[Configuration overview](#)

[Floating roof monitoring input register area](#)



## 5 Operation

### 5.1 Overview

This section contains information on the Light Emitting Diodes (LED) on the front of the system hub. It also includes descriptions of redundancy operation.

### 5.2 Safety messages

Instructions and procedures in this section may require special precautions to ensure the safety of the personnel performing the operations. Information that potentially raises safety issues is indicated by a warning symbol (⚠). Refer to the following safety messages before performing an operation preceded by this symbol.

#### **⚠ WARNING**

**Failure to follow safe installation and servicing guidelines could result in death or serious injury.**

Ensure only qualified personnel perform the installation.

Use the equipment only as specified in this manual. Failure to do so may impair the protection provided by the equipment.

Ensure that the lid on the housing is closed during operation.

### 5.3 Light Emitting Diodes

There are three Light Emitting Diodes (LED) on the front of the Rosemount 2460 System Hub for status and error information.

When the system hub is starting up, all LEDs, (Power, Status, and Error) are lit in order to verify that they work.

In normal operation the Power On and Status LEDs verify that the system hub is up and running.

**Figure 5-1: Three LEDs on the Front**

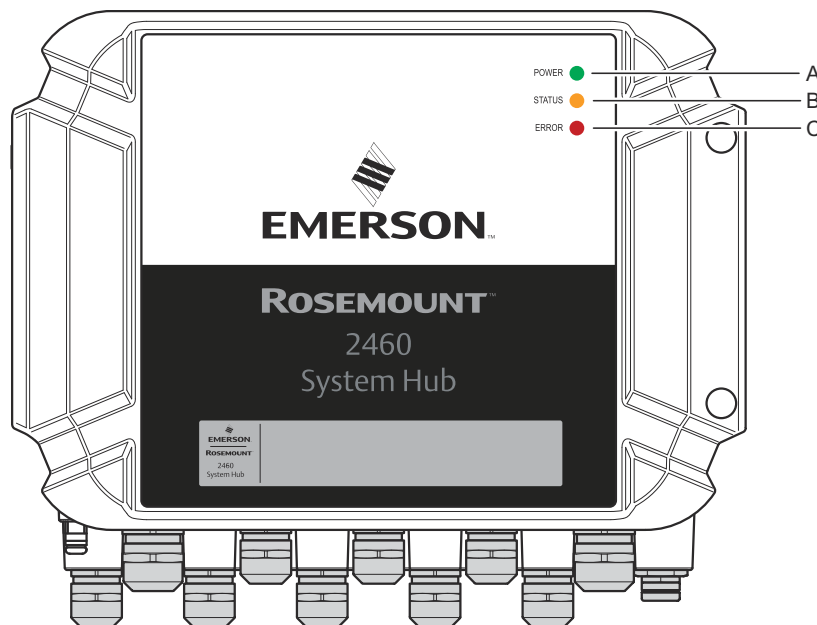

- A. Power On LED (Green)
- B. Status LED (Yellow)
- C. Error LED (Red)

The following color codes are used for the LEDs:

**Table 5-1: LED Color Codes**

LED Type	Color	Description
Power On	Green	The green LED indicates that the system hub is powered on.
Status	Yellow	The yellow Status LED blinks at a constant rate in normal operation to indicate that the software is running.
Error	Red	The red Error LED is turned off in runtime operation. If an error occurs, the Error LED will start to blink. If an error occurs during start-up, the Error LED flashes a sequence that corresponds to a certain error code.

**Related information**

- [Status LED](#)
- [Error LED](#)

### 5.3.1 Start-up procedure

When the system hub is starting up, the LEDs are lit up and turned off in a certain order to indicate proper operation. In case an error is detected during the start-up procedure the red LED remains turned on.

Start-up:

1. All LEDs are turned on
2. Within 0.5 seconds the yellow (Status) LED is turned off.
3. When the start-up procedure is finished, the red (error) LED is turned off. In case an error is detected during the start-up procedure, the error LED will start blinking according to the appropriate error code.
4. The green (power) LED remains lit when the system hub is powered on.

#### Related information

[Error LED](#)

## 5.3.2 Runtime operation

After the start-up procedure is finished the system hub enters runtime mode.

The red Error LED will be turned off. If an error occurs, the LED will start to blink.

In runtime mode the yellow status LED will blink at a rate given by the current operational mode.

#### Related information

[Status LED](#)

[Error LED](#)

## 5.3.3 Error LED

When the system hub is starting up, all the LEDs are turned on. If no error is detected in the start-up procedure, the system hub enters runtime mode and the Error LED (Red) is turned off.

#### Runtime

If an error occurs in runtime mode, the LED will start to blink as follows:

- On=1000 ms
- Off=500 ms

In runtime mode no error codes are presented by the LED. Further information on the particular error can be found in the **Web interface** for the system hub.

**Figure 5-2: Red Error LED**



A. Error LED (Red)

### Start-up

In case an error is detected during the start-up procedure, the error LED will start blinking according to the error code in [Table 5-2](#).

**Table 5-2: LED Error Codes in Start-up Procedure**

Code	Error type	Description
1	Firmware	Upload new firmware. If problem remains contact Emerson Automation Solutions/Rosemount Tank Gauging service department.
2	CDB checksum error	The system hub attempts to restore the Conuration Database (CDB) from the redundant flash memory. If the redundant CDB is corrupt as well, the default CDB is used. You will need to restore conuration by using the Rosemount TankMaster WinSetup conuration tool to upload a backup file to the system hub.
3	RAM used>90%	Reboot the system hub or switch off/on the power. If problem persists contact Emerson Automation Solutions/Rosemount Tank Gauging service department.
4	RAM checksum error	The system hub can not be started.
14	CDB error	Contact Emerson Automation Solutions/Rosemount Tank Gauging service department.
17	Internal system error	Contact Emerson Automation Solutions/Rosemount Tank Gauging service department.

### Example

In case of a device error, the red LED will repeat a flash sequence that corresponds to the particular type of error that occurred. For example, in case of a RAM checksum error (code=4), the LED will show a sequence of 4 flashes followed by a 750 millisecond pause. After the pause the flashing starts over again in the same manner. This flash/pause sequence will be continuously repeated.

RAM checksum error (code 4) appears with the following Error LED (red) flash sequence as illustrated in [Figure 5-3](#).

**Figure 5-3: Example of an Error Code Flash Sequence**

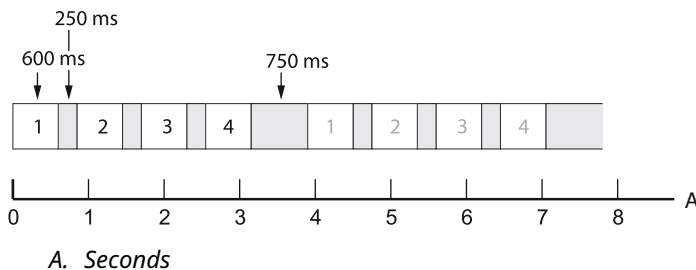

### Related information

[Using the web interface](#)

## 5.3.4

### Status LED

When the system hub is starting up, all the LEDs are turned on. The yellow (Status) LED is turned off within 0.5 seconds.



In runtime operation the Status LED (yellow) blinks at a constant rate as shown in [Table 5-3](#).

**Figure 5-4: Status Information is Presented by the Yellow Status LED**

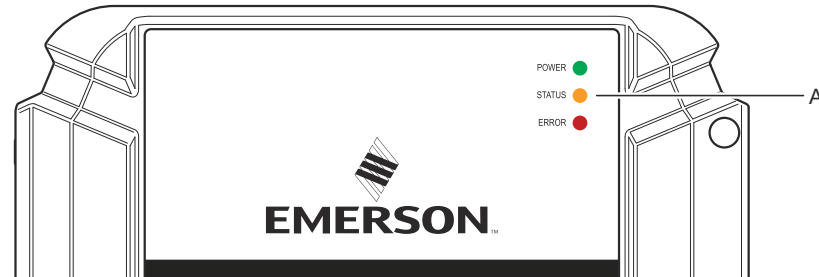

A. Status LED (Yellow)

**Table 5-3: LED Sequence in Runtime Operation**

Status LED (Yellow)	Description
On=50 ms Off=9000 ms	Full mode
On=50 ms Off=200 ms On=50 ms Off=8700 ms	Redundant system; passive (secondary) Rosemount 2460
On=1000 ms Off=500 ms	Reduced mode (warning)

**Example**

The yellow LED will repeat a flash sequence that corresponds to the particular type of status information to be displayed. For example, in Full mode the LED shows a sequence of 1 flash followed by a 9 seconds pause. This flash/pause sequence will be continuously repeated as illustrated in [Figure 5-5](#).

**Figure 5-5: Status Message Flash Sequence in Normal Operation**

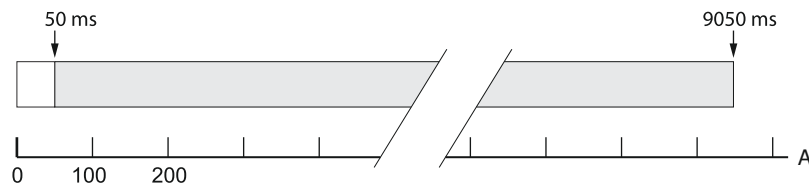

A. Milliseconds

## 5.4 Redundancy operation

### 5.4.1 View redundancy state in TankMaster WinSetup

You may check the current redundancy state by using the Rosemount TankMaster WinSetup.

#### Procedure

1. In the WinSetup workspace, right click the Rosemount 2460 icon.
2. Select the **Properties** option.

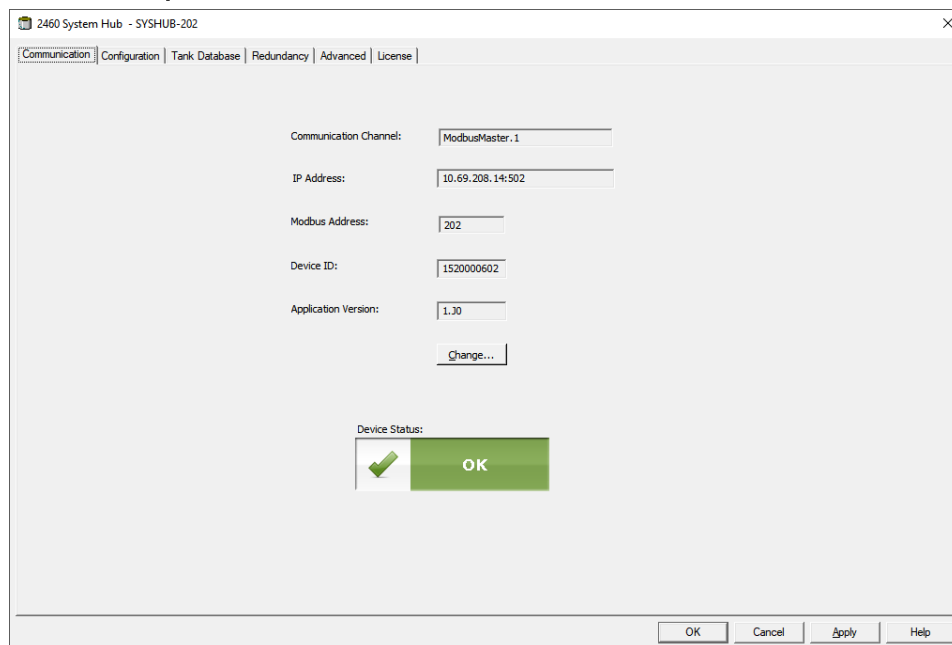

3. Select the **Redundancy** tab.

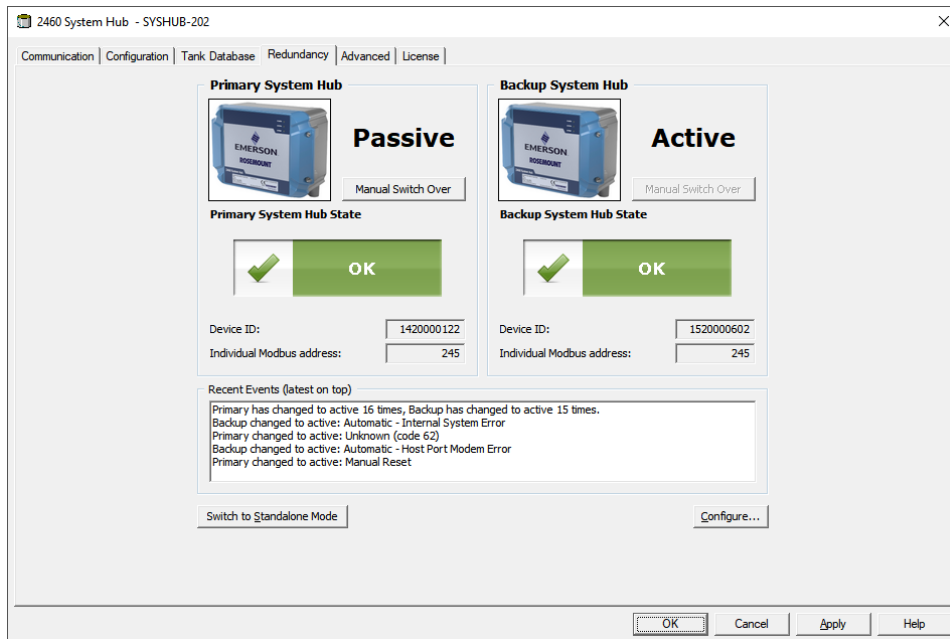

## 5.4.2 View redundancy state using the web interface

### Procedure

1. Connect the TankMaster PC to Ethernet port ETH 3.
2. Open a Web browser.
3. Navigate to the system hub page:
  - a) Type web address 192.168.3.10.
  - b) Log in.
4. Select the **Redundancy** tab.

- Open the **Status** drop-down list to view the current status of **Primary** and **Backup** devices.

The screenshot displays the '2460 System Hub' interface. At the top, it shows 'Device ID: 1420000122' and 'Device Mode: Redundant - Active'. A navigation menu on the left includes Overview, Communication, Configuration, Diagnostics, Redundancy, FW Upgrade, and License. The main content area shows device details and a list of actions: Redundancy Status (with a green checkmark), Manual Switch Over, Configuration, and Unpair. A callout window is open for the 'Redundancy Status' section, showing a detailed comparison between the Primary and Backup devices.

	Primary	Backup
Redundancy status	✓	✓
▼ Device status	<ul style="list-style-type: none"> <li>Redundant system</li> <li>Primary device</li> <li>Active device</li> </ul>	<ul style="list-style-type: none"> <li>Redundant system</li> </ul>
Device warning	✓	✓
Device error	✓	✓
Modem error	✓	✓
Redundancy error or warning		✓
Active counter	16	14

### Related information

[Logging in to the web interface](#)

### 5.4.3 Errors and warnings

You may check the current status of the redundant Rosemount 2460 System Hubs by using the **Properties** option in TankMaster WinSetup.

#### Procedure

1. In the WinSetup workspace, right click the Rosemount 2460 icon and select **Properties**.

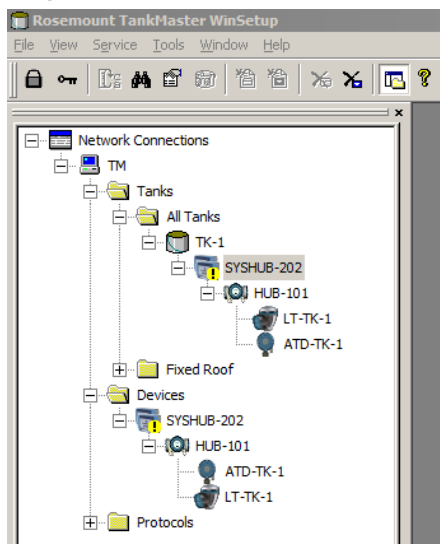

The **Communication** tab will show a warning in case of an error.

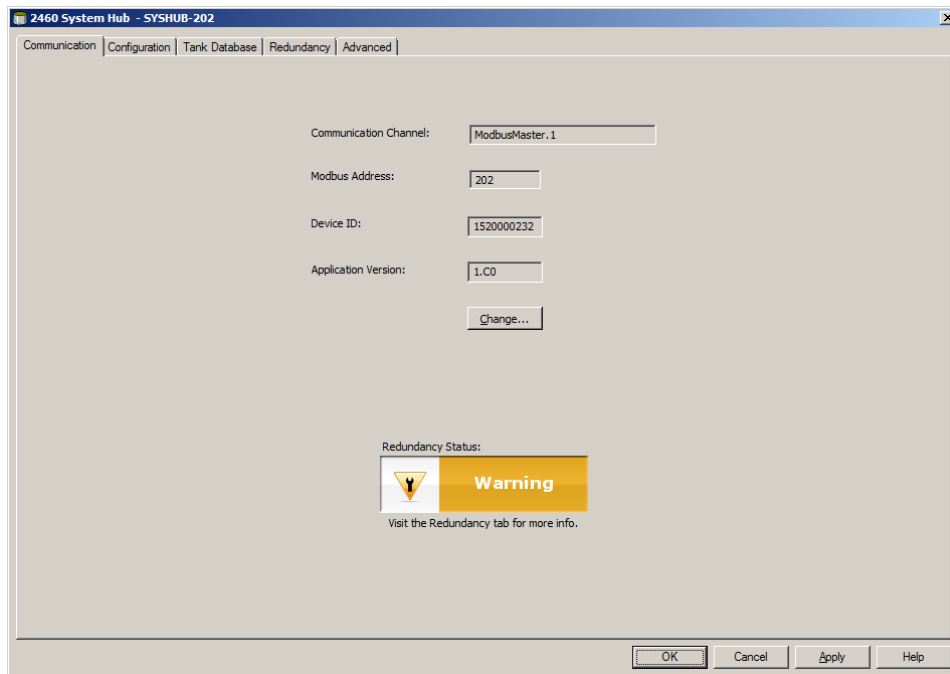

2. Select the **Redundancy** tab for more information.

## State messages for the primary and backup system hubs

State messages for the Primary and Backup system hubs are listed in the following order:

- Redundancy error warnings
- Device error messages
- Primary/backup status
- Modem errors
- Device warnings

Figure 5-6: State Messages

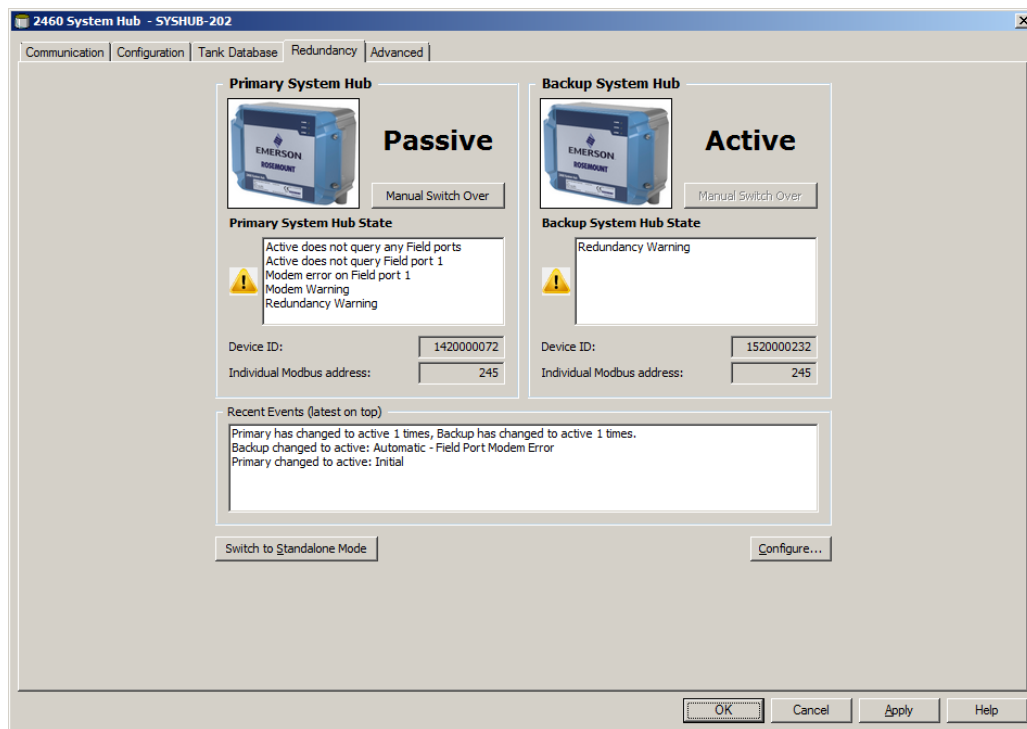

## What will trigger a redundancy warning?

Typical failures that will trigger redundancy warning:

- network cable to backup device disconnected
- backup device powered off
- synchronization of conuration database (CDB) failed
- primary and backup do not have the same type of modem in port <n>
- communication failure due to tank database conured with devices that are not physically connected to the system hub

### 5.4.4 Manual switch over

The Rosemount 2460 System Hubs can be manually switched over from **Active** to **Passive** device.

## Using TankMaster WinSetup

The **Manual Switch Over** button may be used to test that both the Primary and Backup Rosemount 2460 System Hubs function properly as Active or Passive device. It may also be used to reset the devices in case a Fail-over has occurred.

### Procedure

1. In the WinSetup workspace, right click the Rosemount 2460 icon.
2. Choose the **Properties** option and select the **Redundancy** tab.
3. Click the **Manual Switch Over** button.

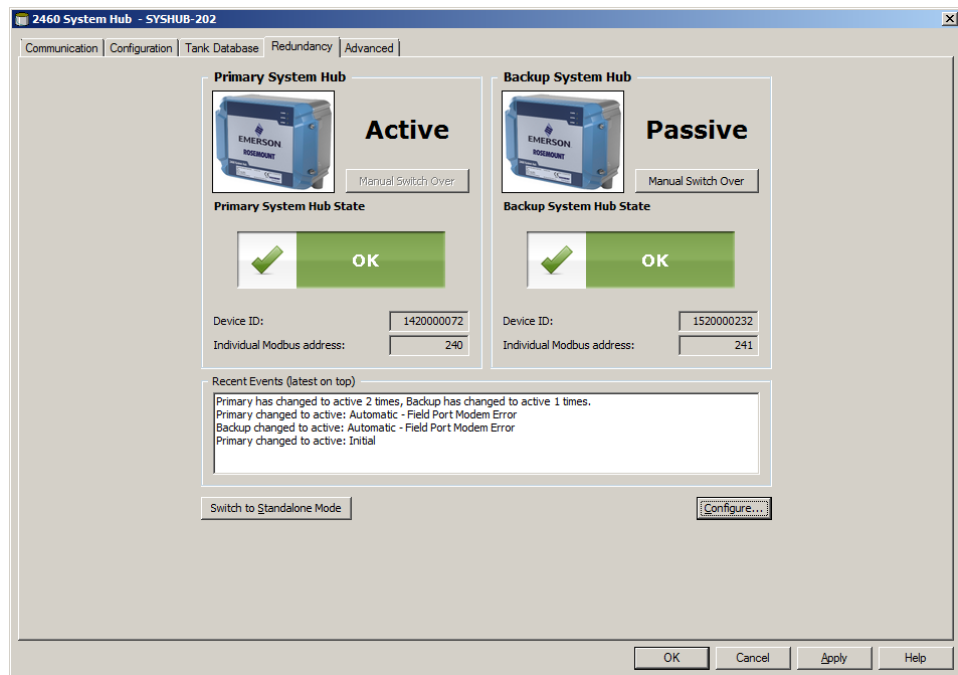

4. Verify that the **Active** device switched to **Passive** and vice versa.

## Manual switch over using the Web interface

### Procedure

1. Log in to the Web interface.
2. Select the **Redundancy** tab.
3. Expand the **Manual Switch Over** option.
4. Click the **Switch Over** button.

5. Verify that the passive device has changed to active mode and the active to passive mode.

The screenshot displays the '2460 System Hub' web interface. At the top, it shows the title '2460 System Hub' and two device icons. Below the title, the 'Device ID: 1420000122' and 'Device Mode: Redundant - Active' are displayed. A navigation sidebar on the left includes 'EMERSON' and menu items: 'Overview', 'Communication', 'Configuration', 'Diagnostics', 'Redundancy', 'FW Upgrade', 'License', and 'User Settings'. The main content area shows the following details:

- Node: Primary Device
- Primary Device ID: 1420000122
- Backup Device ID: 1520000602
- Redundancy Status: ✔
- Manual Switch Over:
- Configuration:
- Unpair:

At the bottom of the interface, there is a footer with the text: 'Copyright © 2015-2019 Rosemount Tank Radar AB | 2460 System Hub Open Source Software Licenses | FW ver. 1.10 - 9987'.

### Related information

[Logging in to the web interface](#)



## 6 Service and troubleshooting

### 6.1 Safety messages

Instructions and procedures in this section may require special precautions to ensure the safety of the personnel performing the operations. Information that potentially raises safety issues is indicated by a warning symbol (⚠). Refer to the following safety messages before performing an operation preceded by this symbol.

#### **⚠ WARNING**

**Failure to follow safe installation and servicing guidelines could result in death or serious injury.**

Ensure only qualified personnel perform the installation.

Use the equipment only as specified in this manual. Failure to do so may impair the protection provided by the equipment.

Do not perform any service other than those contained in this manual unless you are qualified.

#### **⚠ WARNING**

**High voltage that may be present on leads could cause electrical shock.**

Avoid contact with leads and terminals.

Ensure the main power to the Rosemount 2460 System Hub is off and the lines to any other external power source are disconnected or not powered while wiring the 2460.

#### **⚠ CAUTION**

Ensure that there is no water or snow on top of the lid when it is opened. This may damage the electronics inside the housing.

#### **⚠ CAUTION**

Be careful when opening the lid in very low temperatures. High humidity and temperatures far below the freezing point may cause the gasket to get stuck to the lid. In that case you may use a heating fan to warm the housing in order to release the gasket. Be careful not to use excess heat which may damage the housing and electronics.

## 6.2 Tools

The following standard tools are needed for service and maintenance of the Rosemount 2460:

- Screwdriver (Flat or Phillips)
- Wrench
- Torx size 20, 25, and 30 (for opening the lid, connection to ground bar, and exchanging spare parts)

## 6.3 Troubleshooting

Table 6-1 provides summarized maintenance and troubleshooting suggestions for the most common operating problems.

**Table 6-1: Troubleshooting Chart**

Symptom	Possible cause	Action
No contact with the Rosemount 2460 System Hub	Wiring	<ul style="list-style-type: none"> <li>• Check that wires are properly connected to the terminals.</li> <li>• Check for dirty or defective terminals.</li> <li>• Check wire insulation for possible short circuits to ground.</li> <li>• Check that the Rosemount 2460 System Hub is connected to the right communication port on the control room PC.</li> </ul>
	RS485 wiring	<ul style="list-style-type: none"> <li>• Check for proper polarity at the terminals.</li> </ul>
	Field Bus Modem (FBM 2180)	<ul style="list-style-type: none"> <li>• Check that the Tx and Rx LEDs on the FBM are blinking to verify proper communication with the FBM.</li> <li>• Check that the FBM is connected to the right port on the control room PC.</li> <li>• Check that the FBM is connected to the right port on the Rosemount 2460 System Hub.</li> </ul>
No contact with the Rosemount 2460 System Hub	Connection to Rosemount 2460 System Hub	<ul style="list-style-type: none"> <li>• Check communication port LED:s inside the Rosemount 2460. Next to each modem card is a green and a yellow LED for Tx and Rx signals. The LEDs will blink if communication is working properly.</li> </ul>
	Configuration of Rosemount 2460 System Hub	<ul style="list-style-type: none"> <li>• Check the communication address for the Rosemount 2460. Connect a service PC to the Ethernet 3 port and open the <b>Web Interface</b> → <b>Communication</b> tab.</li> <li>• Check configuration of communication parameters for the Rosemount 2460 host ports. Connect a service PC to the Ethernet 3 port and open the <b>Web Interface</b> → <b>Communication</b> tab.</li> <li>• Check that the correct communication channel is selected.</li> </ul>

**Table 6-1: Troubleshooting Chart (continued)**

Symptom	Possible cause	Action
	Configuration of communication protocol	In TankMaster WinSetup/Protocol Channel Properties: <ul style="list-style-type: none"> <li>check that the protocol channel is enabled</li> <li>check the protocol channel configuration (port, parameters, modem).</li> </ul>
	Wrong communication settings	Use TankMaster to check communication settings. For TRL2 modems: Baud Rate=4800, Data bits per character=8, Stop bits=1, no parity. See <a href="#">Table 4-2</a> .
	Connected to wrong modem port	Check which modem is used. Port 7-8 are used for Host communication. Ports 5-6 can be used for Host or field device communication depending on configuration.
	Hardware failure	<ul style="list-style-type: none"> <li>Check the Rosemount 2460 Error LED for information.</li> <li>Check the Field Bus Modem.</li> <li>Check the communication port on the control room PC.</li> <li>Contact Emerson Automation Solutions/Rosemount Tank Gauging service department.</li> </ul>
Impossible to change configuration (write to Holding Registers) of the Rosemount 2460 database	The Rosemount 2460 is write protected	<ul style="list-style-type: none"> <li>Check hardware write protection switch (see <a href="#">Hardware write protection switch</a>)</li> <li>Check software write protection in TankMaster WinSetup</li> </ul>
	Configuration locked by other host system	<ul style="list-style-type: none"> <li>Retry after a couple of minutes</li> </ul>
Process value is invalid	Process value is not valid	<ul style="list-style-type: none"> <li>Check status in Input Registers for the failing field device</li> </ul>
	All process values are invalid	<ul style="list-style-type: none"> <li>Check device status/error Input Registers for the failing field device</li> </ul>
Connected devices don't respond to request	The Rosemount 2460 tank database is not configured	<ul style="list-style-type: none"> <li>Configure Tank Database with TankMaster WinSetup</li> </ul>
	Bad cabling or wrong polarity	<ul style="list-style-type: none"> <li>Check or change cables</li> </ul>
	Wrong communication settings	Use TankMaster to check communication settings. For TRL2 modems: Baud Rate=4800, Data bits per character=8, Stop bits=1, no parity. See <a href="#">Table 4-2</a> .
	The Rosemount 2460 is connected to wrong modem port	Check which modem is used. Ports 1-4 are used for field devices. Port 7-8 are used for host communication. Ports 5-6 can be used for host or field device communication depending on configuration.
	Mismatch between Modbus address in field device and Rosemount 2460 tank database	Ensure that the Modbus address of the field device is configured for the right tank in the system hub's Tank Database. See <a href="#">Step 4. Configure the tank database</a> .

**Table 6-1: Troubleshooting Chart (continued)**

Symptom	Possible cause	Action
Protocol settings are not correct after changing modem card	Protocol is not in AutoDetect mode	Open the <b>Advanced Port Configuration</b> window and set Protocol to Autodetect. <b>Properties</b> → <b>Configuration</b> → <b>Advanced</b> .
Not possible to reset configuration database (CDB) in redundant backup device when all connections between redundant pair have been removed	A redundant backup device will start up as a passive device and it will not be possible to restore CDB to factory default	Use Modbus Host Port and send Modbus requests using the common Modbus address. At first the Backup device will not reply. After a while the backup device will notice that the missing Active device is not responding (since it is not connected). When the Backup device has switched to Active device it will be possible to make a forced unpair in the Web user interface. Then it is possible to restore CDB to default settings.

## 6.4 Exchanging a modem card

The modem cards can be replaced during operation. The Rosemount 2460 System Hub supports plug-and-play and the proper protocol settings will automatically be used when the Rosemount 2460 detects a new modem card.

### Prerequisites

#### Note

Modem status counter will be reset to zero when the modem is installed into the card holder.

### Procedure

1. Loosen the captive locking screws and open the lid.
2. Turn the locking screw 90 degrees and open the modem card cover.

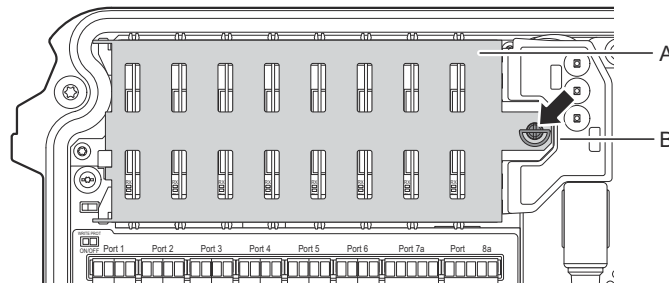

- A. Modem card cover
- B. Locking screw

3. Carefully pull the modem card out.

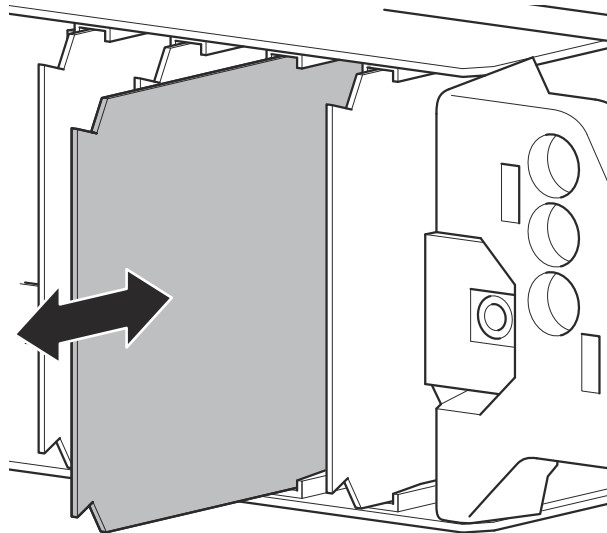

4. Insert the new card into the card holder. Gently push the modem card until it is properly plugged in to the Main board contact.
5. Close the modem card cover.
6. Turn the Locking screw to secure the cover.

7. Ensure that the ring on the Locking screw is folded down to ensure that the lid on the housing can be properly closed.

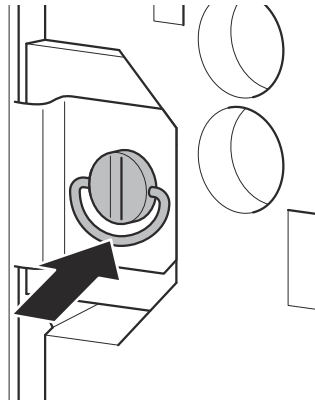

## 6.5 Exchanging the terminal board

### Prerequisites

There are two different versions of the terminal board; standard and emulation modem. The emulation board has the same mechanical layout as the standard version but supports 4-wire modems such as L&J and Varec on Field Ports 1 to 6. It can be identified by its gray terminals unlike the orange terminals on the standard board.

### Procedure

1. ⚠ Turn off power supply by disconnecting external switch.
2. Loosen the captive locking screws and open the lid on the Rosemount 2460 housing.
3. Unplug cables connected to the terminal board.

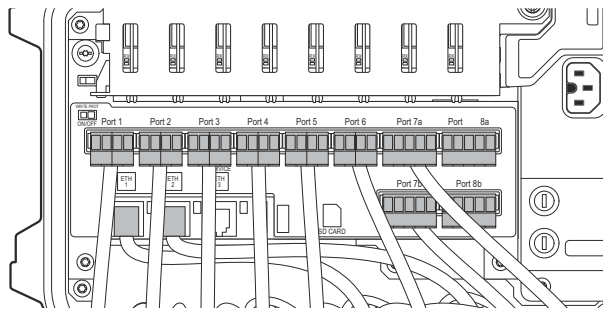

4. Remove the three screws and remove the terminal board cover.

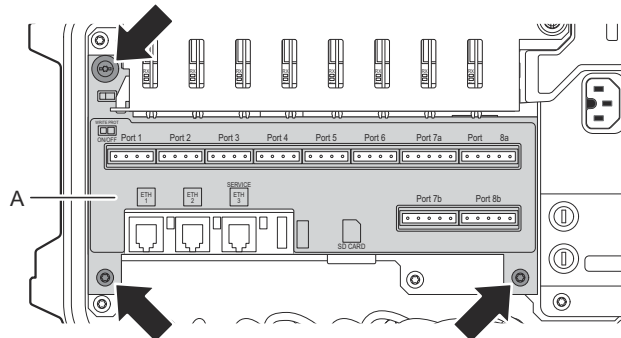

A. Terminal board cover

5. Unscrew the terminal board (eight screws) and carefully remove it from the Main board.

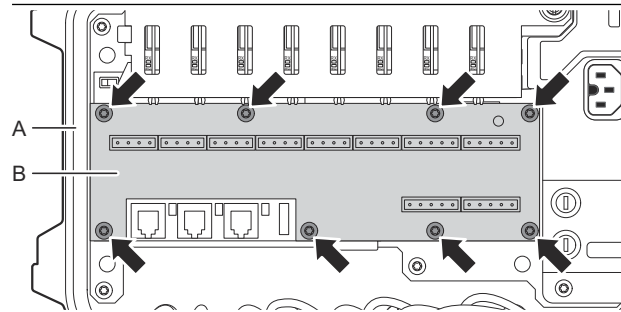

A. Connection to Main board on this side  
B. Terminal board

6. On the new terminal board, locate the Main board connection.
7. Carefully attach the new terminal board. Ensure that it connects properly to the connector in the upper left-hand corner of the Main board.

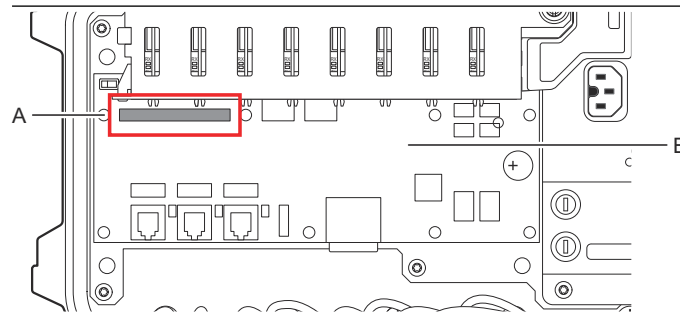

A. Connection to Main board on this side  
B. Terminal board

8. Tighten the screws.
9. Replace the Terminal board cover and the cable connectors.
10. Close the lid on the Rosemount 2460 housing and tighten the two locking screws.



## 6.6 Replacing the power supply unit

### Procedure

1. ⚠ Turn off power supply by disconnecting external switch.
2. Remove the two screws and open the lid on the Rosemount 2460 housing.

---

#### Note

The lid can be removed from the housing if the lock ring is removed. Be careful not to drop the lid on the floor.

---

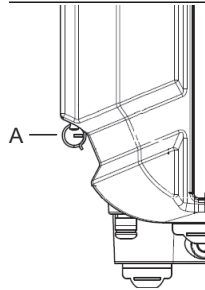

A. Lock ring

---

3. Unplug the power connection.

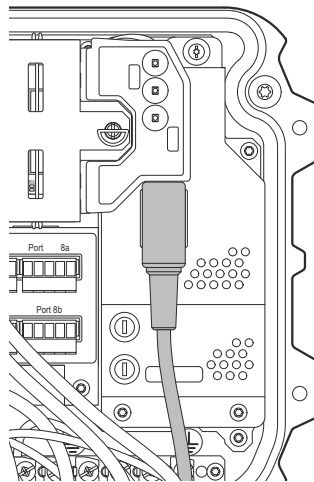

4. Remove the two screws that keep the Power Supply Unit attached to the Main board.

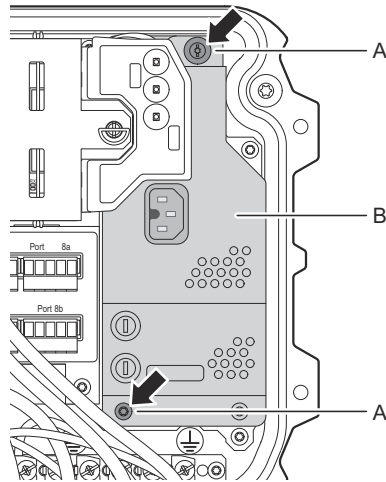

- A. Screw
- B. Power Supply Unit

5. Gently pull out the Power Supply Unit until the Main Board connector is accessible.
6. Unplug the Main Board connector.

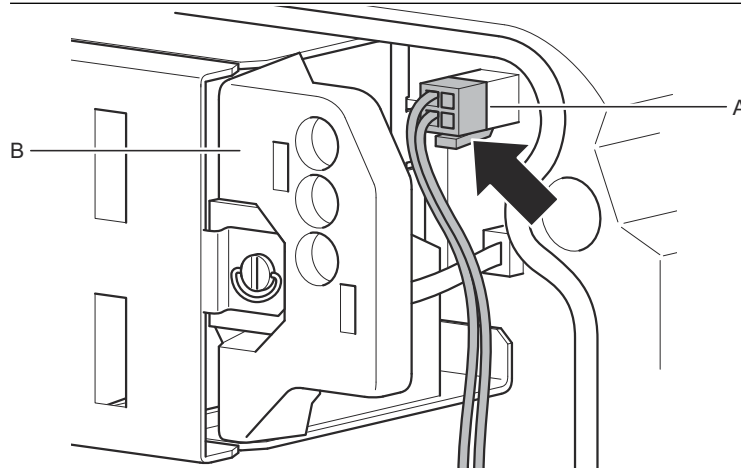

- A. Screw
- B. LED board

7. Remove the Power Supply Unit and replace it with a new one.
8. Tighten the screws, attach the Main Board connector, and plug in the power connection.
9. If removed, replace the lid on the Rosemount 2460 housing and ensure that the lid is secured with the ring.
10. Ensure that the lid is properly closed and sealed.

## 6.7 Using the web interface

The Rosemount 2460 System Hub has a web based graphical user interface that provides a number of useful service functions<sup>(8)</sup>:

- System overview with status information
- Communication status
- Firmware upgrade
- Communication log setup
- Modbus TCP configuration
- Network configuration
- Configuration database upload to System Hub
- Configuration database download to PC
- License upgrade
- Log file download to PC
- Redundancy setup
- Inventory configuration
- User defined Modbus mapping
- Floating Roof Monitoring setup

Most of these functions may be accessed via either of the Rosemount TankMaster configuration software or the Web Graphical User Interface (GUI). However, some functions, such as the Network and Modbus TCP configuration, can only be accessed via the Web GUI.

To access the Web Interface the service computer must be connected to the **Ethernet 3** port.

The Web Interface can be opened in Web browsers such as Chrome and Firefox by navigating to IP-address 192.168.3.10. The Rosemount 2460 System Hub will act as a DHCP server and the connected PC will automatically receive a valid ip address.

### Related information

[Terminal board and ports](#)

---

<sup>(8)</sup> Note that some options require license.

## 6.7.1 Logging in to the web interface

The Rosemount 2460 provides several protection levels allowing you to prevent unauthorized changes. In order to change device configuration you must be logged on to the appropriate user access level.

You can be logged on as **Administrator** or in **View Only** mode. The default user names and passwords are:

**Table 6-2: User Access Levels and Sub Levels**

User	Level	Default password
View	VIEW ONLY	view
Administrator	ADMINISTRATOR	admin

### Note

It is recommended that you change to a new password once you logged in the first time.

### Procedure

1. Navigate to the appropriate IP-address. Default address=192.168.3.10.
2. Enter the appropriate user name and password.

**Figure 6-1: Login Page for Rosemount 2460 Web User Interface**

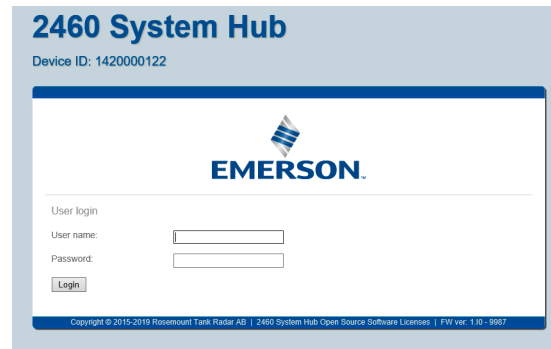

3. Once you are logged in, the web interface appears with a number of menus that represent various service functions.

Figure 6-2: Web User Interface

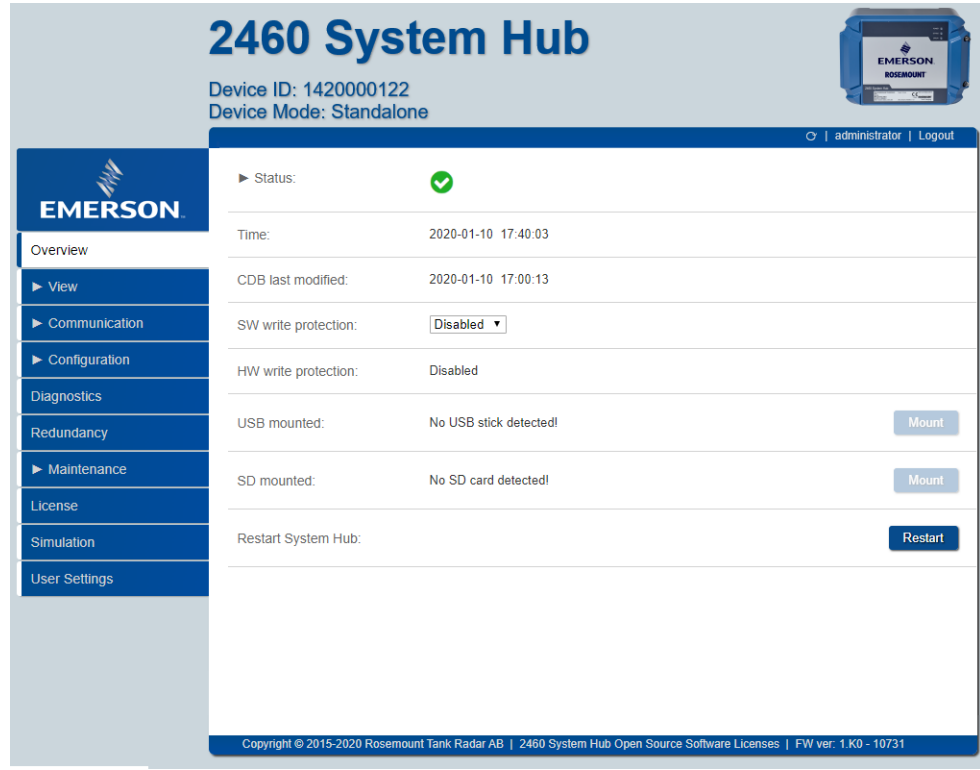

## 6.7.2 Menus in the web user interface

**Table 6-3: Menus in the Rosemount 2460 Web User Interface**

Menu	Description	
Overview	<p>Presents information on:</p> <ul style="list-style-type: none"> <li>firmware version</li> <li>device ID</li> <li>device mode</li> <li>status such as OK, device warning, and device error</li> <li>software and hardware write protection</li> <li>current time</li> </ul> <p>The <b>Overview</b> tab also shows whether a SD memory card or/and a USB device is mounted.</p>	
View	Tank 1-16	Shows data for the first 16 tanks. In case there are more tanks installed, new sub menus will appear for the remaining tanks: Tank 17-32, and Tank 33-48, Tank 49-64.
Communication	Ports statistics	lets you view the current field and host port status
	Logging	lets you setup the Rosemount 2460 to log communication on field and host ports and download log files to a PC
	Modbus TCP statistics	lets you view status of communication counters and errors
Configuration	Time	lets you specify date, time, time zone, and adjustment for Daylight Saving Time
	Ports	lets you configure communication parameters for field and host ports
	Network	lets you configure network communication parameters
	Modbus TCP	lets you configure Modbus TCP communication parameters
	User Defined Server	lets you edit and create a Modbus map file in order to emulate a user defined Modbus server
	User Defined Device	lets you edit and create a Modbus map file in order to emulate a user defined Modbus device
	CDB	Lets you backup the current configuration database (CDB) or upload an existing database
	System Values	lets you configure certain system parameters and system units
	Manual Values	manual values for inventory parameters
	Inventory	lets you set up a tank for volume calculations
	Strapping Table	lets you specify a strapping table of up to 5000 points
	Floating Roof Monitoring	lets you configure tanks, devices, and alert limits for floating roof monitoring
Tank Name	Lets you edit tank names for display in <b>View Tank Data</b> window	
Diagnostics	Shows various status information such as operating hours, device and application uptime, performance and more	
Redundancy	Lets you configure a redundant pair of system hubs	
Maintenance	2460 System Hub	Lets you upgrade firmware of a Rosemount 2460
	Field Device	Lets you upgrade firmware of field devices.

**Table 6-3: Menus in the Rosemount 2460 Web User Interface (continued)**

<b>Menu</b>	<b>Description</b>
License	Lets you upgrade the Rosemount 2460 with new software options
Simulation	Lets you simulate tanks and parameter values
User Settings	Lets you change password

## 6.8 User settings

The **User Settings** tab lets you change password for the currently logged in user. You may also configure automatic logout.

Figure 6-3: User Settings

The screenshot displays the Emerson User Settings page. On the left is a navigation sidebar with the Emerson logo and menu items: Overview, View, Communication, Configuration, Diagnostics, Redundancy, Maintenance, License, Simulation, and User Settings. The main content area is titled 'User Settings' and includes a breadcrumb 'administrator | Logout'. It features two sections: 'Change Password' with three input fields for 'Current Password', 'New Password', and 'Repeat New Password', and an 'Apply' button; and 'Logout preferences' with a dropdown menu for 'Automatic logout of 'View' user:' showing 'Enabled', 'Enabled', and 'Disabled' options. The footer contains the text: 'Copyright © 2015-2019 Rosemount Tank Radar AB | 2460 System Hub Open Source Software Licenses | FW ver. 1.10 - 10378'.

### Logout preferences

Enable/disable automatic logout after login session exceeds 30 minutes. This applies for user category "View".

### Password

Passwords must be at least 4 characters.

### Related information

[Logging in to the web interface](#)

### 6.8.1 Change the password

#### Procedure

1. Enter the current password for the user in the **Current Password** field.
2. Enter the new password in the **New Password** field.
3. Repeat the same new password in the **Repeat New Password** field.
4. Click the **Apply** button.



## 6.9 View tank

The **View** option lets you view inventory and level data. This option requires **Inventory license**.

Figure 6-4: View Tank Data in the Rosemount 2460 Web Interface

Tank	ROV (%)	Level (m)	Flow (m <sup>3</sup> /h)	TOV (m <sup>3</sup> )	NSV (m <sup>3</sup> )	WIV (ton (m))	AVRM (m <sup>3</sup> )	
TK-1001	80%	10.000	196.8	16000.000	14319.764	14319.764	4000.000	More
TK-1002	54%	10.200	356.8	16320.000	14621.195	14621.195	13600.000	More
TK-1003	42%	10.400	516.8	16640.000	14940.967	14940.967	23360.000	More
TK-1004	94%	10.600	676.8	16960.000	15223.948	15223.948	1040.000	More
TK-1005	96%	10.800	836.8	17280.000	15525.270	15525.270	720.000	More
TK-1006	93%	11.000	996.8	17600.000	15826.555	15826.555	1400.000	More
TK-1007	90%	11.200	1156.8	17920.000	16127.805	16127.805	2080.000	More
TK-1008	87%	11.400	1316.8	18240.000	16429.018	16429.018	2760.000	More
TK-1009	74%	11.600	1476.8	18560.000	16730.195	16730.195	6440.000	More
TK-1010	79%	11.800	1636.8	18880.000	17031.336	17031.336	5120.000	More
TK-1011	83%	12.000	1796.8	19200.000	17332.440	17332.440	3000.000	More
TK-1012	89%	12.200	1956.8	19520.000	17633.508	17633.508	2480.000	More
TK-1013	94%	12.400	2116.8	19840.000	17934.540	17934.540	1160.000	More
TK-1014	81%	12.600	2276.8	20160.000	18235.536	18235.536	4840.000	More
TK-1015	60%	12.800	2436.8	20480.000	18536.495	18536.495	9520.000	More
TK-1016	69%	13.000	2596.8	20800.000	18837.418	18837.418	9200.000	More

Tank data is refreshed at a rate of ten seconds.

A bar graph shows tank movements exceeding flow rate of 0.01 m<sup>3</sup>/hour.

The tank name can be changed as desired. See menu option **Configuration** → **Tank name**.

The **View** window shows parameters as described in Table 6-4.

Table 6-4: Parameters in Tank View

Parameter	Description
ROV	Relative Observed Volume
Level	Level
Flow	Flow
TOV	Total Observed Volume
NSV	Net Standard Volume
WIV	Weight in Vacuum
AVRM	Available Volume Room

On the right-hand side of the **View** window, you may select the **More** option to view detailed information on the selected tank.

Figure 6-5: View Tank Data Details

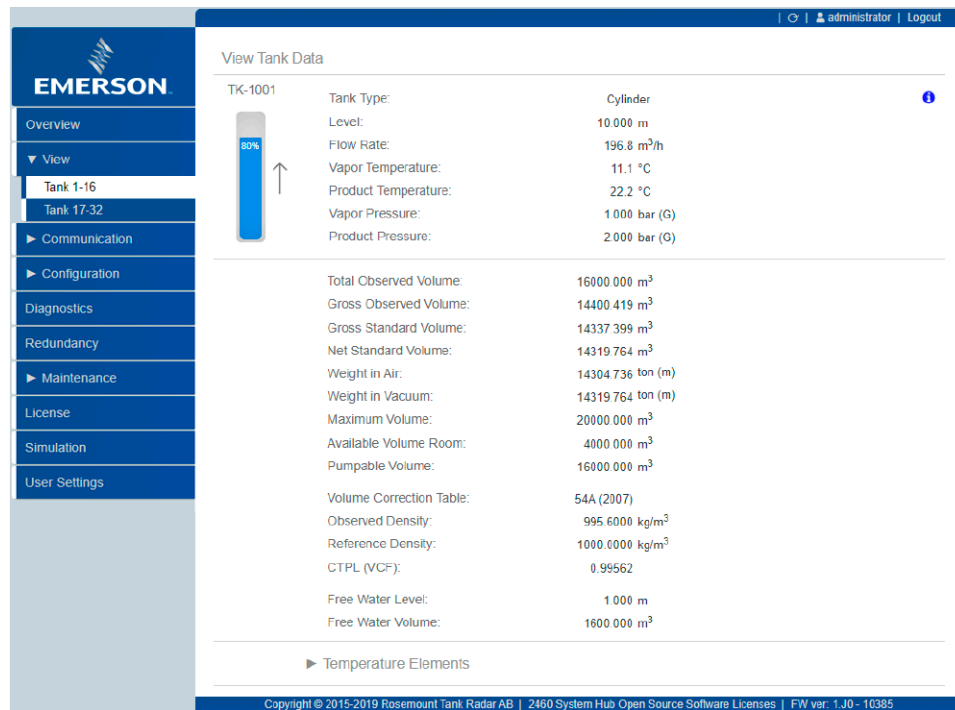

### Temperature elements

By expanding the **Temperature Elements** section, you can see more information about all temperature elements. There is also extra status indication for each of the temperature elements, such as **In vapor** or **In product**.

Only the temperature elements that are being used are visible. **In vapor** or **In product** statuses will only be shown if this information is available from the source field device.

### Status for measurement values

The status for measurement values can be one of the following:

- Invalid
- Comm Fail
- Out of service
- Disconnected
- Simulated
- Manual
- Backup
- Blank (if the value is OK)

Status for calculated inventory values can be either **Invalid** or **blank**. Blank indicates that the value is correct, regardless if it comes from a device or is simulated.

## 6.9.1 Change tank name in View Tank Data window

It is possible to edit tank names for the **View Tank Data** window. Names may include up to ten alphanumeric characters.

You may use uppercase, lowercase, special characters, and digits. Characters such as "<", ">" or "/" are not allowed.

**Figure 6-6: Tank Name Configuration**

The screenshot displays the 'Tank Name Configuration' interface. On the left is a navigation menu with the Emerson logo and options: Overview, View, Communication, Configuration (expanded), Time, Ports, Network, Modbus TCP, User Defined Server, User Defined Device, Database, System Values, Manual Values, Inventory, Strapping Table, and Tank Name. The main area shows a table of tanks with columns for index, name field, and name. The top right corner indicates the user is 'administrator' and provides a 'Logout' link.

Tanks:	[#]	Name	[#]	Name
	1	TK-1001	33	TK-1033
	2	TK-1002	34	TK-1034
	3	TK-1003	35	TK-1035
	4	TK-1004	36	TK-1036
	5	TK-1005	37	TK-1037
	6	TK-1006	38	TK-1038
	7	TK-1007	39	TK-1039
	8	TK-1008	40	TK-1040
	9	TK-1009	41	TK-1041
	10	TK-1010	42	TK-1042
	11	TK-1011	43	TK-1043
	12	TK-1012	44	TK-1044
	13	TK-1013	45	TK-1045
	14	TK-1014	46	TK-1046
	15	TK-1015	47	TK-1047
	16	TK-1016	48	TK-1048
	17	TK-1017	49	TK-1049
	18	TK-1018	50	TK-1050

## 6.10 Ports statistics

The **Ports statistics** option lets you view the current status of all field ports and host ports.

**Figure 6-7: Communication Tab in the Rosemount 2460 Web Interface**

Port	Modem	Protocol	Type	Address	I-Reg map	Settings	Rx Msgs	Tx Msgs	Status
1	TRL2	Modbus	FP	---	---	4800, 8, N, 1	23014691	23021679	✓
2	BPM	Enraf GPU	FP	---	---	1200, 7, O, 1	0	0	✓
3	TRL2	Modbus	FP	---	---	4800, 8, N, 1	2797439	2797467	✓
4	BPM	Enraf GPU	FP	---	---	1200, 7, O, 1	0	0	✓
5	DCL	Sakura V1	FP	---	---	2400, 8, E, 1	0	0	✓
6	---	---	---	---	---	---	---	---	---
7	TRL2	Modbus	HP	202	2460	4800, 8, N, 1	0	0	✓
8	RS485 T	Modbus	HP	202	2460	9600, 8, N, 1	0	0	✓

Clear counters

Copyright © 2015-2019 Rosemount Tank Radar AB | 2460 System Hub Open Source Software Licenses | FW ver. 1.K0 - 10731

For each port this window shows what type of protocol that is used and the various communication addresses and parameters as well as Rx and Tx communication counters.

Parentheses around a port number shows that it is in "Single Port Mode".

Hovering the cursor over a port number shows whether it is licensed or not.

## 6.11 Setup a communication log

Via a Web browser you may setup the Rosemount 2460 System Hub for logging the communication on all field and host ports. Log files are stored on a SD card or a USB stick.

### Procedure

1. Install a USB stick or a SD card.

#### Note

USB stick and SD card should be FAT32 formatted.

2. Open the Web interface for the Rosemount 2460 System Hub.
3. Select the **Communication** → **Logging** menu option.

The screenshot displays the 'Communication Log Settings' page in the Emerson Rosemount 2460 System Hub web interface. The interface is in English and shows the following settings:

- Log destination:** Radio buttons for  USB (No USB stick detected!) and  SD (No SD card detected!).
- Max file size [KB]:** Input field with value 100 and range [100-10000].
- Max number of files:** Input field with value 1 and range [1-10].
- Port logging enabled:** Checkboxes for ports 1 through 8, all of which are checked.
- Modbus TCP logging:** Radio buttons for  None,  Client 1 - 10.69.208.94,  Client 2 - 10.68.204.115,  Client 3 - 10.69.208.101,  Client 4 - 10.69.208.47, and  Client 5 - 10.69.209.13.
- Advanced Communication Filtering:** Expandable sections for Port and Modbus TCP.
- Buttons:** 'Apply', 'Clear Filtering and Apply', and 'Download'.

At the bottom of the page, there is a footer with copyright information: Copyright © 2015-2019 Rosemount Tank Radar AB | 2460 System Hub Open Source Software Licenses | FW ver. 1.J0 - 10378.

4. Enable ports to be logged by selecting the corresponding check boxes.
5. For Modbus TCP, select the desired client.  
You can log one client at a time.
6. Specify **Max file size** and **Max number of log files**.  
It is recommended to set "Max number of log files" to two or more. Then you can combine these two parameters to avoid that a file is overwritten.

- Specify log destination USB or SD card.  
The log files will be stored in a folder named “comlogs”. File names will be given by the following syntax:

- Port logging: “ComLog\_Port<1-8>\_<01-10>.txt”.
- Modbus TCP client: “ComLog\_Client1\_01.txt”.

### Example

“ComLog\_Port2\_03.txt” refers to the third log file for communication port number 2.

“ComLog\_Client1\_02.txt” refers to the second log file for Client 1.

- Setup advanced filtering options for the ports to be logged.

For each port you may choose:

- any device address or a specific address
- function code (Modbus), or TOR (Enraf® GPU)
- status, i.e. various error type

FW Upgrade  
License  
User Settings

### Advanced Communication Filtering

▼ Port

▼ Port 1 - FP - Modbus

Log address:  Any  Selected  [0-255]

Log frames with status:  Timeout error  Checksum error  Other error  OK

Log FC:  Any  Selected

► Port 2 - FP - Enraf

► Port 3 - FP - Modbus

► Port 4 - FP - Enraf

► Port 5 - FP - Sakura V1

► Port 6

► Port 7 - HP - Modbus

► Port 8 - HP - Modbus

► Modbus TCP

Log(s)

Communication logs:

Copyright © 2015-2019 Rosemount Tank Radar AB | 2460 System Hub Open Source Software Licenses | FW ver. 1.J0 - 10378

- Click the **Apply** button to start logging.

### Note

A SD card or USB memory must be available, otherwise logging will not start.

Logging will continue until it is stopped manually.

### Related information

[Using the web interface](#)

[Stop communication logging](#)

[Components](#)

## 6.11.1 Communication log files

When the maximum number of files is reached, the first file will be overwritten. If no log filtering is applied to a port, communication events for approximately 18-20 hours, equal to 100 MB of data (maximum 10 files and 10 MB of data per file), will be available before being overwritten by newer communication events.

It is recommended to turn off logging when it is not needed.

### Note

If communication logs are enabled and a write protected SD-card is selected as storage media, system will enter warning mode **SD card warning**.

## 6.11.2 Stop communication logging

### Procedure

1. Make sure that all ports are disabled, i.e. all check boxes are unchecked. Also make sure that **Modbus TCP logging** is set to **None**.

### Note

Modbus TCP does only appear in case the current license includes Modbus TCP Host Communication.

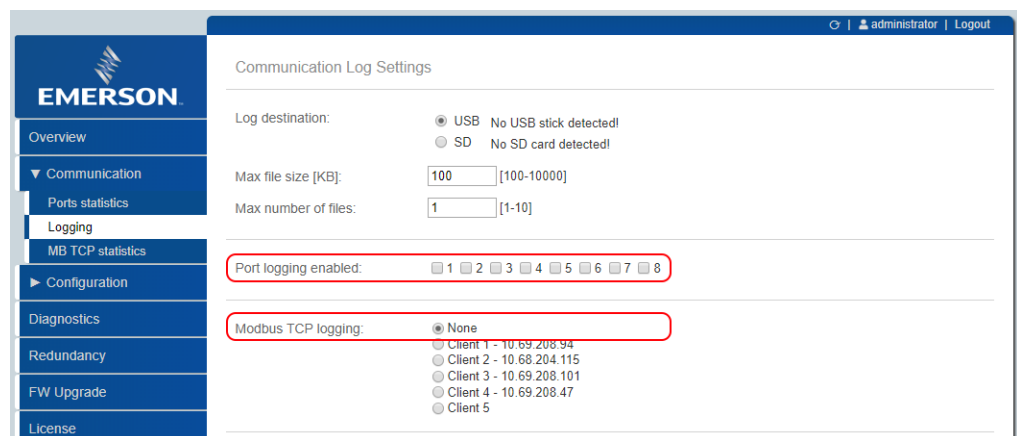

2. Click the **Clear Filtering and Apply** button.

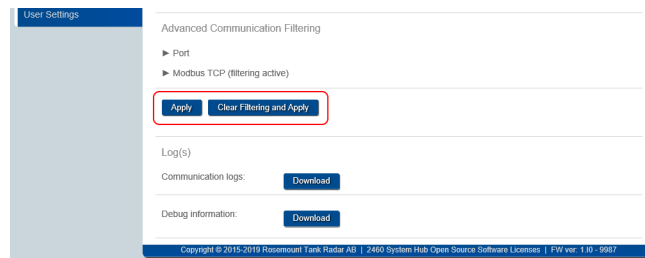

### Related information

### Ordering information

## 6.11.3 Downloading log files to a PC

Log files can be transferred to a PC by using one of the two methods:

- Remove the USB stick or SD card and copy the log files to the desired location on a PC.
- Download via the Web interface.

### Related information

[Copy from USB stick or SD card](#)

[Downloading via the Web interface](#)

### Copy from USB stick or SD card

It is important that the USB stick/SD card is unmounted before removing it, otherwise log data may be lost.

### Prerequisites

#### Note

Logging will stop temporarily in case a USB stick or SD card is unmounted, logging will be resumed when the USB stick /SD card is replaced again.

### Procedure

1. Unmount the USB stick/SD card.
  - a) In the Web Interface select the **Overview** menu option.



2. Click the **Unmount** button.
3. Remove the USB stick/SD card and insert it into a PC.
4. Copy the log files from the “Comlogs” folder to the desired destination folder on the PC.

#### Note

Logging will be resumed when the USB stick/SD card is inserted into the Rosemount 2460 again.

### Downloading via the Web interface

#### Prerequisites

Note that logging will halt during download.

#### Procedure

1. Open the Web interface for the Rosemount 2460 System Hub.
2. Select the **Communication** → **Logging** menu option.



3. Click the **Communication logs: Download** button.

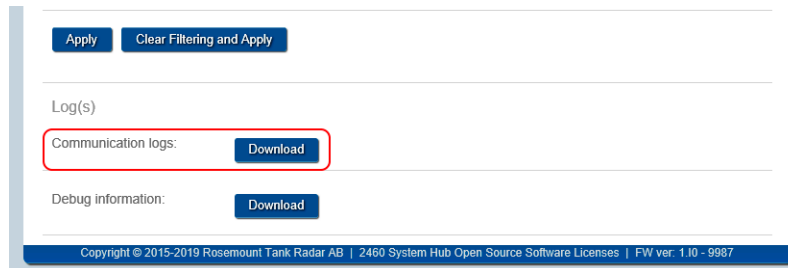

Depending on the particular web browser that is used, the database file will be downloaded to the default folder for file download on the PC, or you may choose the desired destination folder.

---

#### Note

Downloading the log files may take up to ten minutes depending on the amount of data.

---

Once the database is downloaded, the file can be moved to the preferred location.

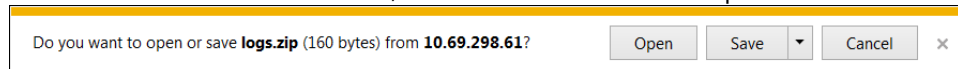

#### Related information

[Using the web interface](#)

## 6.12 Modbus TCP configuration

The Modbus TCP implementation is limited by license. License options are available depending on the required number of Modbus TCP clients. The Modbus TCP license options are:

- Disabled
- Two TankMaster clients
- Single client
- Five clients

If Modbus TCP is enabled by license the network configuration has to be set according to user requirements.

Figure 6-8: Modbus TCP Configuration

The screenshot displays the 'Modbus TCP Configuration' page in a web browser. The left sidebar contains the Emerson logo and a navigation menu with categories: Overview, View, Communication, Configuration (expanded), Time, Ports, Network, Modbus TCP (expanded), User Defined Server, User Defined Device, Database, System Values, Manual Values, Inventory, Strapping Table, Tank Name, Diagnostics, Redundancy, Maintenance, License, and Simulation. The main content area is titled 'Modbus TCP Configuration' and includes a user profile 'administrator' and a 'Logout' link. The configuration is organized into sections: 'TCP ports' (Port number: 502, Extra port number: 50502), 'Response time' (Max response time: 800 ms, Max FC17 resp. time: 100 ms), 'TCP Keep-Alive' (Idle time: 60 s, Interval time: 5 s, Count: 5), and 'Client whitelisting'. A callout box points to the 'Whitelist' section, which has 'Use whitelisting' checked and 'IP address 1' set to 10.10.0.11. An 'Apply' button is located at the bottom left of the configuration area. The footer contains copyright information: 'Copyright © 2015-2019 Rosemount Tank Radar AB | 2460 System Hub Open Source Software Licenses | FW ver. 1.K0 - 10731'.

**Table 6-5: Modbus TCP Configuration**

Menu	Description
Extra Port number	If needed, an extra Modbus TCP port may be specified in the range 50000 to 65535. 502 is the default port.
Max. response time	Maximum response time. No response within this time interval is regarded as communication failure.
Max. response time, FC17	Maximum response time for FC17 (device identification).
Idle time	Time until TCP keep alive starts in case there is no active communication between the Rosemount 2460 and the host. TCP keep alive sends transmissions to verify that the idle connection is still active.
Interval time	Interval for TCP keep alive messages.
Count	Number of lost TCP keep alive messages before it is considered that there is no connection to the host.
Client white listing	Restricts replies via Modbus TCP IP (Eth 1) to system hub for selected IP addresses <sup>(1)</sup> .

*(1) A minimum of one IP address must be specified, otherwise the system hub will not send any replies.*

Recommendations by TCP/IP Implementation Guide V1.0:

- It is recommended to keep the TCP connection opened with a remote device and not to open and close it for each MODBUS/TCP transaction.
- It is recommended for a MODBUS Client to open a minimum of TCP connections with a remote MODBUS server (with the same IP address). One connection per application could be a good choice.

## 6.13 User defined Modbus

See [Modbus® standard question](#).

## 6.14 Modbus TCP statistics

The Modbus TCP statistics option lets you view the current status of communication counters and errors. It shows the total number of connections, number of active connections, as well as the Modbus TCP register map that is used.

Figure 6-9: Modbus TCP Statistics

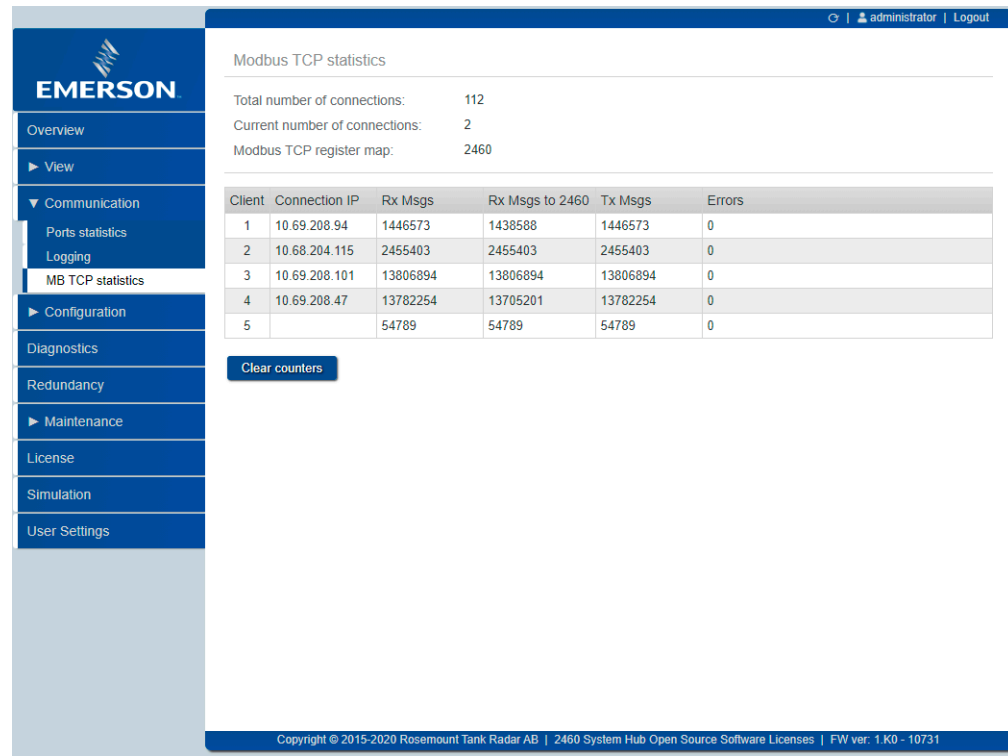

## 6.15 Time

The **Time** window lets you specify date, time, and time zone. You may also configure for Daylight Saving Time.

**Figure 6-10: Time Configuration**

The screenshot displays the 'Time Configuration' page in the Emerson System Hub. The left sidebar contains navigation options: Overview, Communication, Configuration (expanded), Time (selected), Ports, Network, Modbus TCP, User Defined Server, User Defined Device, Database, System Values, Manual Values, Inventory, Strapping Table, Diagnostics, Redundancy, FW Upgrade, License, and User Settings. The main content area shows the current system time and time zone. Below this, the 'Set date and time' section includes a checkbox for 'Sync date and time with this computer', a date input field (2020-01-13), a time input field (10:41:54), and a time zone dropdown menu (UTC+01:00). There is also a checkbox for 'Automatically adjust clock for Daylight Saving Time (DST)'. An 'Apply' button is located at the bottom of the configuration section.

### Set date and time

Check the **Sync date and time...** check box in case you like to synchronize date and time with the connected computer.

The **Automatically adjust clock for Daylight Saving Time (DST)** setting switches on or off the system hub's DST setting.

Most of the time zones in Northern America, Europe and some time zones in the Middle East are affected by DST (the rest of the time zones do not observe DST). Time zones that support DST show (DST) next to their time zone if DST is on, and nothing if DST is off. The unaffected time zones show nothing no matter if the DST is on or off.

### Related information

[Setting the real-time clock](#)

## 6.16 Ports

Figure 6-11: Ports Configuration

The screenshot shows the 'Ports Configuration' page in the EMERSON System Hub. The left sidebar contains navigation options: Overview, View, Communication, Configuration (selected), Time, Ports (selected), Network, Modbus TCP, User Defined Server, User Defined Device, Database, System Values, Manual Values, Inventory, Strapping Table, Tank Name, Diagnostics, Redundancy, Maintenance, License, Simulation, and User Settings. The main content area displays a table of port configurations:

Port	Modem	Protocol	Type	Address	I-Reg map	Settings	Adv.
1	TRL2	Auto	Modbus	FP	---	---	4800, 8, N, 1 ...
2	TRL2	Auto	Modbus	FP	---	---	4800, 8, N, 1 ...
3	TRL2	Modbus	Modbus	FP	---	---	4800, 8, N, 1 ...
4	BPM	Auto	Enraf GPU	FP	---	---	1200, 7, O, 1 ...
5	DCL	Sakura V1	Sakura V1	FP	---	---	2400, 8, E, 1 ...
6	RS485 T	Auto	Modbus	FP	---	---	9600, 8, N, 1 ...
7	None	---	---	HP	---	---	---
8	RS485 T	Auto	Modbus	HP	202	2460	9600, 8, N, 1 ...

Below the table, there is a section for 'Redundant Field Ports' with the following settings:

- Enable field port pairs:  1-2  3-4  5-6
- Passive FP check interval (s):  [60-3600]
- Modbus server address:  [1-245]

An 'Apply' button is located below the settings. The footer of the interface contains the text: 'Copyright © 2015-2020 Rosemount Tank Radar AB | 2460 System Hub Open Source Software Licenses | FW ver. 1.K0 - 10731'.

### Protocol options

The **Protocol** option can be used to select protocol other than the default protocol based on installed modem type. This is useful in case an electrical interface supports several protocol types.

Figure 6-12: Protocol Options

The screenshot shows a dropdown menu titled 'Protocol'. The menu is open, displaying the following options: Auto (highlighted), Modbus, Enraf, L&J, Varec, Whessoe 550, Whessoe 660, GPE, TIC, Sakura V1, and Sakura MDP. The current selection is 'Auto'.

### Type options

You may choose **Field Port** or **Host Port** for ports 5 and 6 in case this is supported by the current license.

### Input register mapping options

I-reg map 2460 is the default option. Other options are available depending on license:

- 2460
- 2160/2165
- User defined
- Enraf GPU

### Modbus server address

Modbus server address refers to the address that is used for host communication.

### Advanced port configuration

The **Advanced** column has a button that lets you open extended configuration options. The **Advanced Port Configuration** window lets you change from standard port configuration to a non-standard configuration. This is a useful option if, for example, the system hub is connected to a host system that requires manual port configuration. Then you can configure protocol and communication parameters to match the requirements for the host.

Enable non standard configuration by selecting the **Non Standard** check box.

### Note

Non standard configuration is not supported for all modem types.

Figure 6-13: Advanced Port Configuration

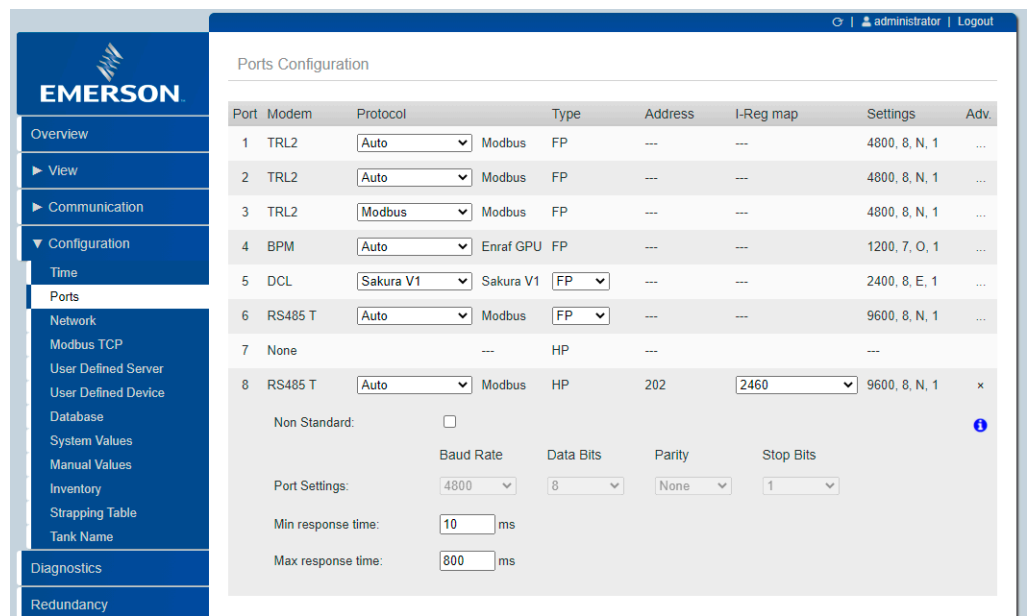

Non standard settings may be needed in case field devices connected to different field ports use different communication parameters such as baud rate. Then each port can be configured independently from the other ports.

In case the system hub is located far away from the host, non-standard settings may be required since maximum communication speed for RS232 and RS485 depends on the cable length. Some emulation protocols use the same type of modem card. Therefore, you

may need to specify communication protocol and configure parameters for the particular protocol to be used.

---

**Note**

For modem type **RS485 T** the "T" means that termination is enabled.

---

## 6.16.1 Redundant field ports

The Redundant Field Ports functionality requires that redundancy license is enabled.

Two field ports can be configured in a redundant primary/backup pair. If the primary port is experiencing communication problems, the backup port will take over after a number of retries. The number of retries can be configured.

Status of the passive port is checked after a specific time interval. You may edit this interval in the **Passive FP check interval (s)** input field. A switch over to backup port will only take place if the backup port status is OK.

If the backup port is active, a switch over will take place in case the primary port status becomes OK. If backup port is experiencing problems the primary port becomes active.

Redundant field ports can be used with redundant Rosemount 2460 system hubs.

### Setup

To be able to use the redundant field port feature the only supported modems are pairs of TRL2 and RS485 (2 wire).

For RS485 modems the ports must use the same communication parameters (baud rate, data bits etc.). For TRL2 communication the parameters are not configurable.

The field devices must be connected in a loop that begins from the primary port and ends at the backup port. It is possible to break the loop to add more field devices without interrupting the communication.

The pairs are limited to be any of ports 1 and 2, 3 and 4 and/or 5 and 6. Note that ports 5 and 6 must be configured as field ports.



Figure 6-14: Redundant Field Port Settings

The screenshot shows the 'Ports Configuration' page in the Emerson Rosemount 2460 System Hub. The interface includes a left-hand navigation menu with options like Overview, View, Communication, Configuration, Time, Ports, Network, Modbus TCP, User Defined Server, User Defined Device, Database, System Values, Manual Values, Inventory, Strapping Table, Tank Name, Diagnostics, Redundancy, Maintenance, License, Simulation, and User Settings. The main content area is titled 'Ports Configuration' and contains a table with the following data:

Port	Modem	Protocol	Type	Address	I-Reg map	Settings	Adv.
1	TRL2	Auto	Modbus FP	---	---	4800, 8, N, 1	...
2	TRL2	Auto	Modbus FP	---	---	4800, 8, N, 1	...
3	TRL2	Modbus	Modbus FP	---	---	4800, 8, N, 1	...
4	BPM	Auto	Enraf GPU FP	---	---	1200, 7, O, 1	...
5	DCL	Sakura V1	Sakura V1 FP	---	---	2400, 8, E, 1	...
6	RS485 T	Auto	Modbus FP	---	---	9600, 8, N, 1	...
7	None	---	HP	---	---	---	...
8	RS485 T	Auto	Modbus HP	202	2460	9600, 8, N, 1	...

Below the table is the 'Redundant Field Ports' section, which includes the following configuration options:

- Enable field port pairs:  1-2  3-4  5-6
- Passive FP check interval (s):  [60-3600]
- Modbus server address:  [1-245]

An 'Apply' button is located at the bottom of the configuration section. The footer of the page contains the text: 'Copyright © 2015-2020 Rosemount Tank Radar AB | 2460 System Hub Open Source Software Licenses | FW ver. 1.K0 - 10731'.

## 6.17 Network

The **Network** tab lets you configure the Rosemount 2460 for communication on the Ethernet port 1 (Eth1). It also allows you to setup the system hub for digital certificates and HTTPS web protocol.

Figure 6-15: Network Configuration

Table 6-6: Network Configuration

Menu	Description
Web protocol	Available options are HTTP and HTTPS. Allows you to use SSL certificates and HTTPS protocol for secure encrypted communication. Requires SSL keys to be generated and installed.

**Table 6-6: Network Configuration (continued)**

Menu	Description
Mode	Available mode options are DHCP (dynamic IP address), Static and Disabled. DHCP is not recommended for redundant systems.
IP Address	IP address in static mode (common IP Address in a redundant system).
Netmask	Netmask in static mode.
Gateway	Enter the gateway's IP address in case the Rosemount 2460 is connected to the host system via a gateway.
MAC address	MAC address of the network adapter.
Specific IP Address for Primary Device	In a system with redundant system hubs, static IP address is recommended. This field allows you to set a static IP address for the Primary device in a redundant system. Can be changed only if the "Redundancy" license option is enabled.
Specific IP Address for Backup Device	In a system with redundant system hubs, static IP address is recommended. This field allows you to set a static IP address for the Backup device in a redundant system. Can be changed only if the "Redundancy" license option is enabled.

### 6.17.1 Recommendations for Modbus TCP IP addressing

Network mode "Static" is the recommended selection for Eth1. There is neither a default IP address nor a default Netmask since they depend on the local network environment and the IP settings of the host PC. The recommendation is however to use IP addresses in the so-called private address range according to [Table 6-7](#).

**Table 6-7: Recommended IP Address Ranges**

IP Address range	Netmask	Comment
10.0.0.1- 10.255.255.254	255.0.0.0	Use tighter Netmask if possible, e.g. 255.255.255.0.
172.16.0.1- 172.31.255.254	255.240.0.0	Use tighter Netmask if possible, e.g. 255.255.255.0.
192.168.0.1-192.168.0.254	255.255.255.0	Be aware of the Eth3 static IP Address of 192.168.3.10, i.e. it is recommended to not enable this full range! See further below.

IP addressing for the ETH1 port must not interfere with the settings of ETH2 and ETH3.

It is not recommended to use the private address 192.168.X.Y with a netmask of 255.255.0.0 since the ETH3 IP address 192.168.3.10 is located within this Netmask range. Using a tighter Netmask, e.g. "255.255.255.0", will enable the use of IP address starting with "192.168.X" where X can be any number other than 3.

IP address in the range 9.X.Y.Z is not allowed since this IP range is reserved for Eth2 and the redundancy connection.

Always avoid using the network and broadcast address on an interface. (0 and 255 for a default Class C network.)

## 6.17.2 Digital SSL certificates

Digital certificates allow clients to check if the received data is coming from a trusted Server (Client/Server model). Clients can connect to Rosemount 2460 using digital certificates.

---

### Note

You are responsible for system security, practices, and processes, and for the proper configuration and use of the Rosemount 2460 product.

---

Secure Sockets Layer (SSL) is used when connecting to the Web GUI via Hypertext Transfer Protocol Secure (HTTPS). SSL uses certificates to establish secure connections. These certificates are located on the server (Rosemount 2460) and exchanged when a client connects.

### Chain of trust

SSL uses Chain of Trust which separates it into multiple keys chained together. The chain begins with a root key which is usually created by a trusted organization, but it can also be created by anyone (self-signed). In the Rosemount 2460 you create a self signed root certificate in the system hub itself, as well as the necessary intermediate certificates.

After a self-signed root key has been created it needs to be installed as a trusted authority on the computer that is used to access the web server to be considered secure in modern browsers. One or multiple intermediate keys can be chained, linking to each other, with the root at the top.

### Redundant system hubs

The SSL keys on the primary device are used by the backup Rosemount 2460 as well. Once keys are generated they will automatically be synchronized to the backup unit.

### Key generation

Before you enable HTTPS web protocol the first time, you must generate both **root** and **intermediate** certificates.

In case you change network settings such as IP addresses later on, you need to generate a new intermediate certificate only.

## Generate SSL certificates

This is a description of how to generate digital certificates for secure encrypted communication with Rosemount 2460 System Hub.

### Prerequisites

- Make sure that time and time zone are correct. This is to ensure that generated SSL keys start date will be correct.
- Ensure that regular network settings are properly configured including all IP addresses

### Procedure

1. In the Web user interface, navigate to **Configuration** → **Network**.
2. Check that Web protocol is set to HTTP. When SSL certificate installation is completed, you will need to change this setting to HTTPS. It is recommended to use HTTP protocol during installation and change to HTTPS afterwards to avoid any web browser issues.
3. Generate SSL keys by selecting the appropriate **Create** button:
  - Intermediate key
  - Root & Intermediate keys

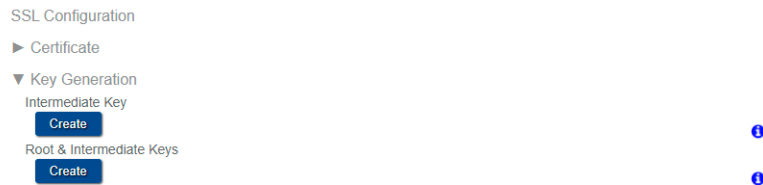

For a new installation select the **Root & Intermediate Keys** option.

For existing system which has a root certificate installed use the **Intermediate Keys** option. This option is typically used when network changes, such as IP addresses, have been performed.

4. A pop-up message will appear with the message "Updating SSL". When certificate generation is ongoing, it is still possible to navigate to other pages in the Web interface. When certificate generation is completed, a short interruption will occur when the Web interface is restarted.

### Note

Certificate generation may take up to 10 minutes.

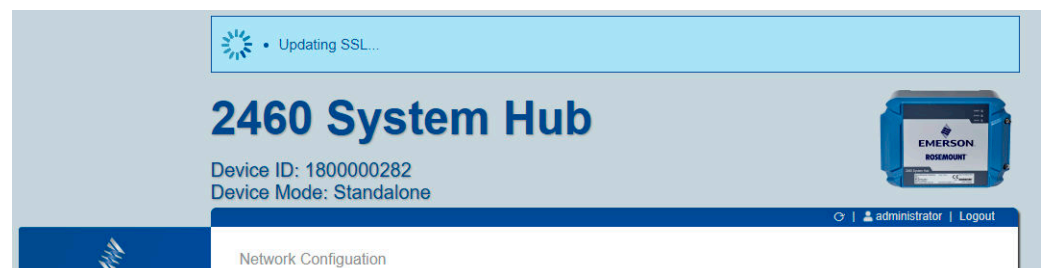

- Once certificate generation is completed you may view information about Root and Intermediate certificates on the **Configuration** → **Network** page.

SSL Configuration

▼ Certificate

[Download](#)



Root Certificate	
Thumbprint:	d92d7b5313441cb979db9e83cce3f1b44d740b06
Valid Between:	Mar 18 11:26:30 2021 GMT - Feb 22 11:26:30 2121 GMT
Issuer:	C=SE, ST=Sweden, O=Emerson, CN=Emerson System Hub CA
Intermediate Certificate	
Thumbprint:	00c8fe117fa4f73e637610d3c45f336ee90e1c15
Valid Between:	Mar 26 08:44:06 2021 GMT - Mar 2 08:44:06 2121 GMT
Subject Alternative Name:	192.168.3.10, 10.10.0.106

► Key Generation

**Table 6-8: Certificates**

Certificate Type	Description
<b>Root certificate</b>	
Thumbprint	A unique identifier
Valid between	Specifies the dates when the certificate is valid
Issuer	Specifies what trusted authority generated the root certificate
<b>Intermediate certificate</b>	
Thumbprint	A unique identifier
Valid between	Specifies the dates when the certificate is valid
Subject alternative name	Specifies what IP addresses the certificate can be used for; this needs to match your network settings

**Postrequisites**

Once the certificates are generated, proceed with installing the certificates.

**Related information**

[Install SSL certificates by using installation wizard](#)

## Install SSL certificates by using installation wizard

To install a trusted authority on the client (web browser), you will need to download the root certificate. An installation wizard lets you easily install the generated certificates.

### Procedure

1. In the Web user interface, navigate to **Configuration** → **Network**.
2. Under **SSL Configuration**, open **Certificate** and select **Download**.

The default file name of the downloaded file is **server\_root.crt**.

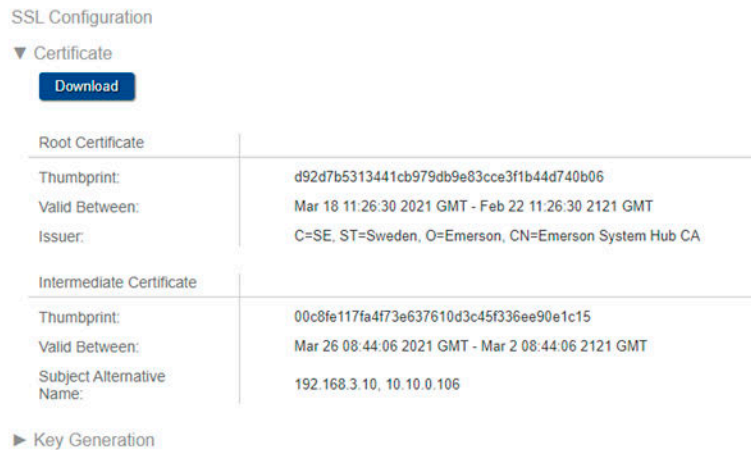

3. Right-click the certificate file **server\_root.crt** and select **Install Certificate**.

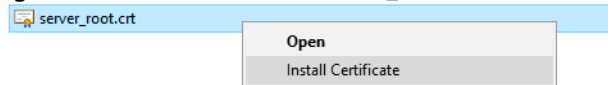

4. Select **Open** to start the installation wizard.

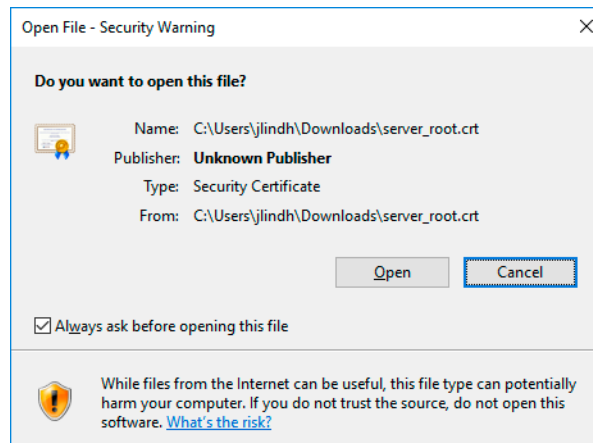

5. Select store location **Local Machine**, and click **Next** to continue.

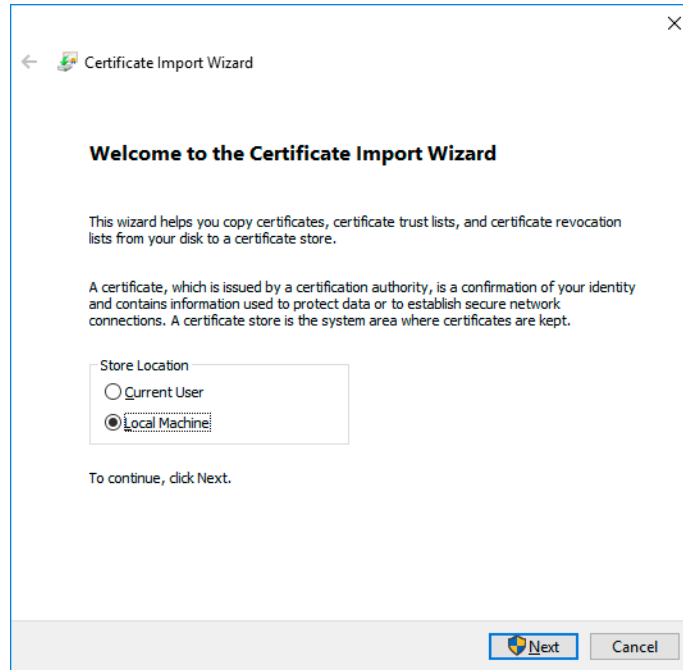



6. Select **Browse** to locate the folder named **Trusted Root Certification Authorities**.

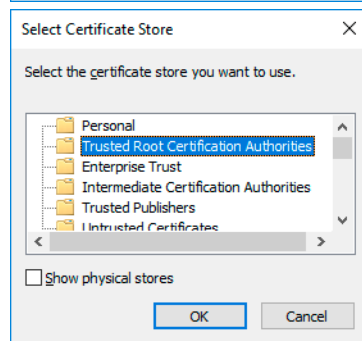
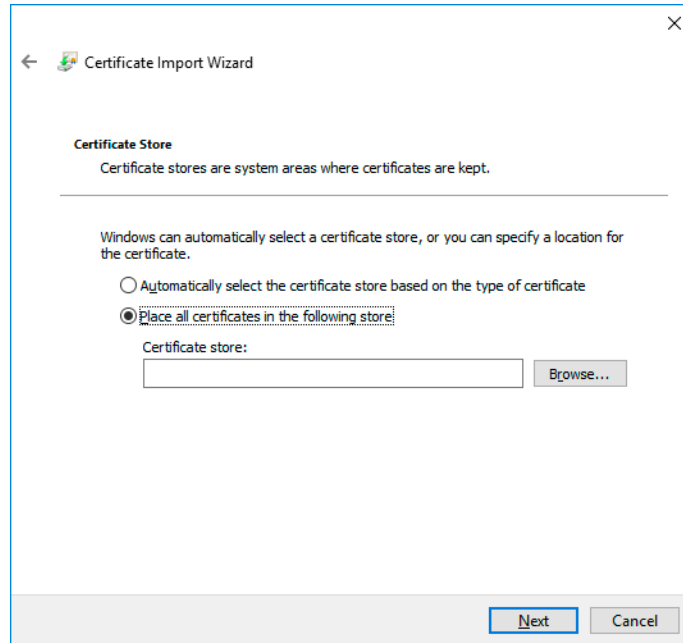

7. Select **Next** to continue.

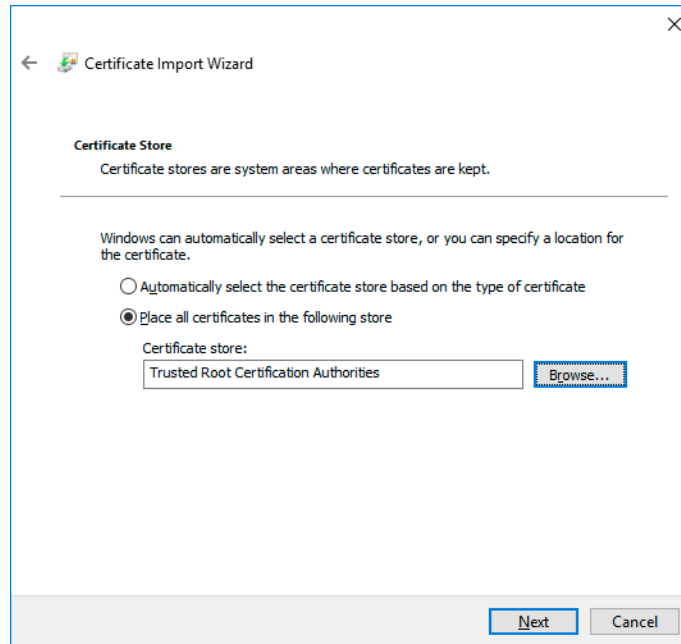

8. Verify the specified settings and click **Finish**.

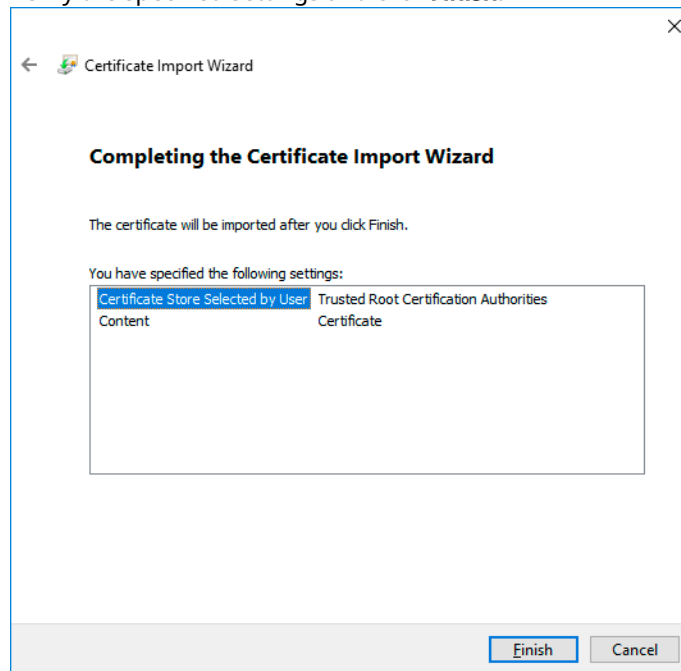

9. Once the certificates are installed, restart the Web browser. Then change Web protocol from HTTP to **HTTPS** in the 2460 configuration.

### Related information

[Switch Web protocol to HTTPS](#)

## Switch Web protocol to HTTPS

Follow this procedure to enable Web protocol HTTPS.

### Prerequisites

Ensure that digital SSL certificates are generated and installed.

### Procedure

1. In the Web interface navigate to **Configuration** → **Network**.
2. Change Web protocol to HTTPS and click **Apply**.

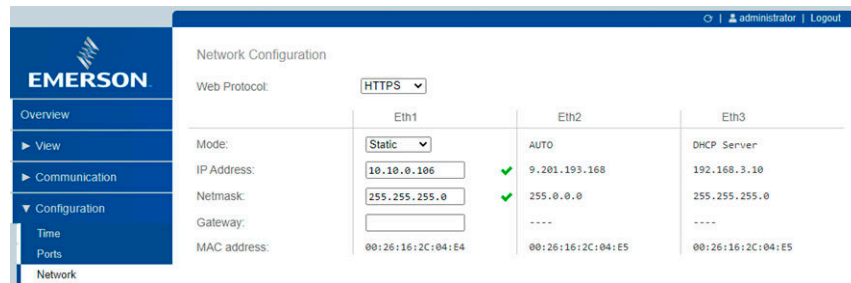

3. Now you will have to change URL address to use HTTPS instead of HTTP.

### Example

**http://**192.168.3.10 needs to be changed to **https://**192.168.3.10.

4. In Chrome a padlock indicates safe connection.



### Related information

[Generate SSL certificates](#)

[Install SSL certificates by using installation wizard](#)

## 6.18 Diagnostics

The **Diagnostics** page provides information on current device status.

Figure 6-16: Diagnostics

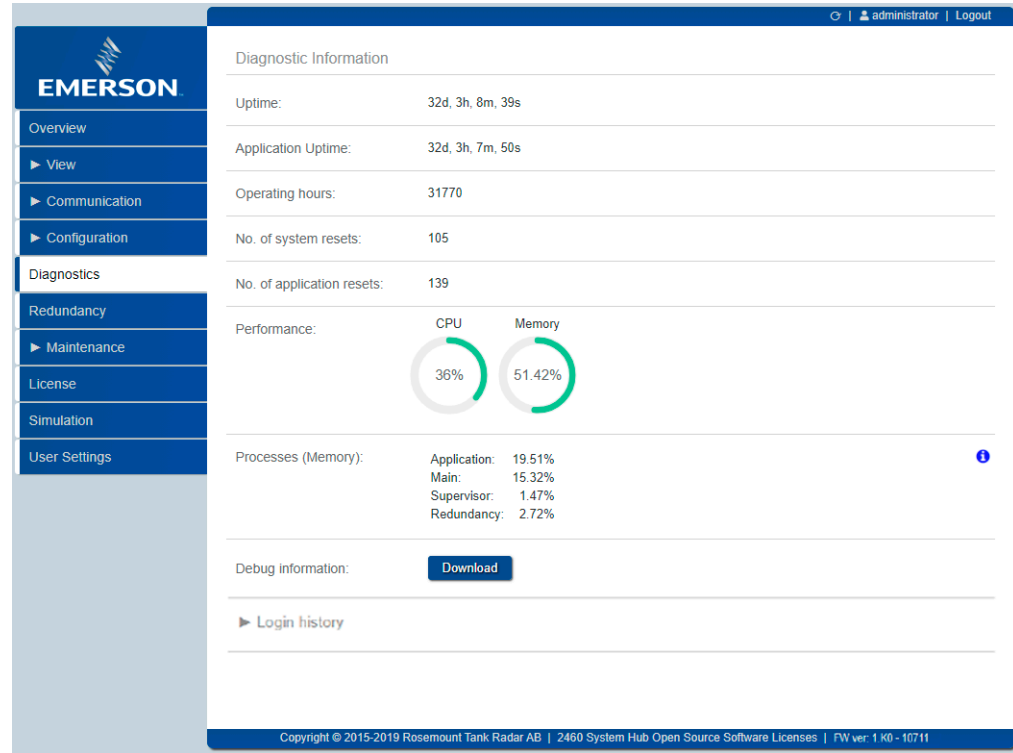

Table 6-9: Diagnostics Information

Item	Description
Uptime	Time since the system hub was powered on or rebooted
Application Uptime	Time since the system hub firmware application started
Operating hours	Number of hours the system hub has been powered on since first time
No. of system resets	Number of system resets (device reboot)
No. of application resets	Number of application resets (main application restart)
Performance	CPU and Memory usage
Processes (Memory)	Memory usage for each process running in Rosemount 2460 system
Debug information	Download button will download a zip-file with message logs and potential core-dump files (debuginfo)
Login history	Shows login history for up to 500 items.

### Debug information

In case a status message such as “Warning Debug Info Exists” appears, you will have to press the Debug Information **Download** button in order to clear this warning message. The download button lets you store a data file that can be used for troubleshooting.

The **Download** button can be used even if no warning message appears. This allows you to use debug information as a tool for advanced troubleshooting.

## 6.18.1 View and configure diagnostic registers using TankMaster™

The Rosemount TankMaster WinSetup program lets you view the current device status. The **View Diagnostic Register** window shows a selection of database registers that gives you an instant view of how the gauge operates. You may also configure the window by adding registers of special interest.

### Procedure

1. In the **TankMaster WinSetup** workspace window, right-click the device icon.

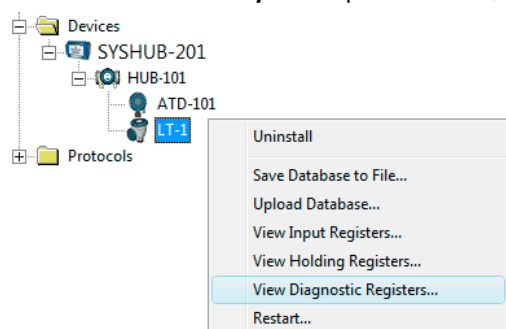

2. Right-click and select **View Diagnostic Registers**.

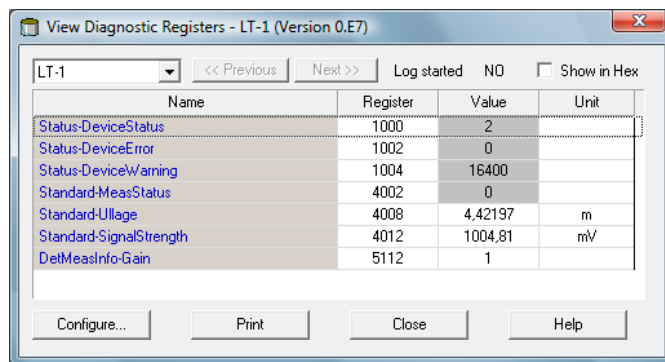

### Diagnostics registers window

The register values in the diagnostics window are of read only type. They are loaded from the device as the window is opened.

A grey background color of the table cell in the Value column means that the register is of either Bitfield or ENUM type. An expanded Bitfield/ENUM window can be opened for this type of register. Double-click the cell to open the Expanded Bitfield/ENUM window.

If needed, the values can be presented as hexadecimal numbers. This applies to all registers of Bitfield and ENUM types. Select the **Show in Hex** check box to present Bitfield and ENUM registers as hexadecimal numbers.

The **Configure** button lets you open the *Configure Diagnostic Registers* window where you can change the list of registers to be displayed in the *View Diagnostic Registers* window. See the Rosemount Tank Gauging [System Configuration Manual](#) for more information.

The ***Configure Diagnostic Registers*** window also has a **Log Setup** button for access to the ***Register Log Scheduling*** window which allows you to setup a log schedule for automatic start and stop of register logging.

## 6.19 Restore to factory defaults

You may erase the current configuration and reset the Rosemount 2460 System Hub to factory defaults.

### Prerequisites

#### Note

Restoring the system hub to factory default can not be reversed. It is recommended to save the configuration database (CDB) first. Then you may return to the current configuration.

### Procedure

1. Open the system hub's Web interface.
2. Select **Configuration** → **Database**.
3. Click the **Restore** button.

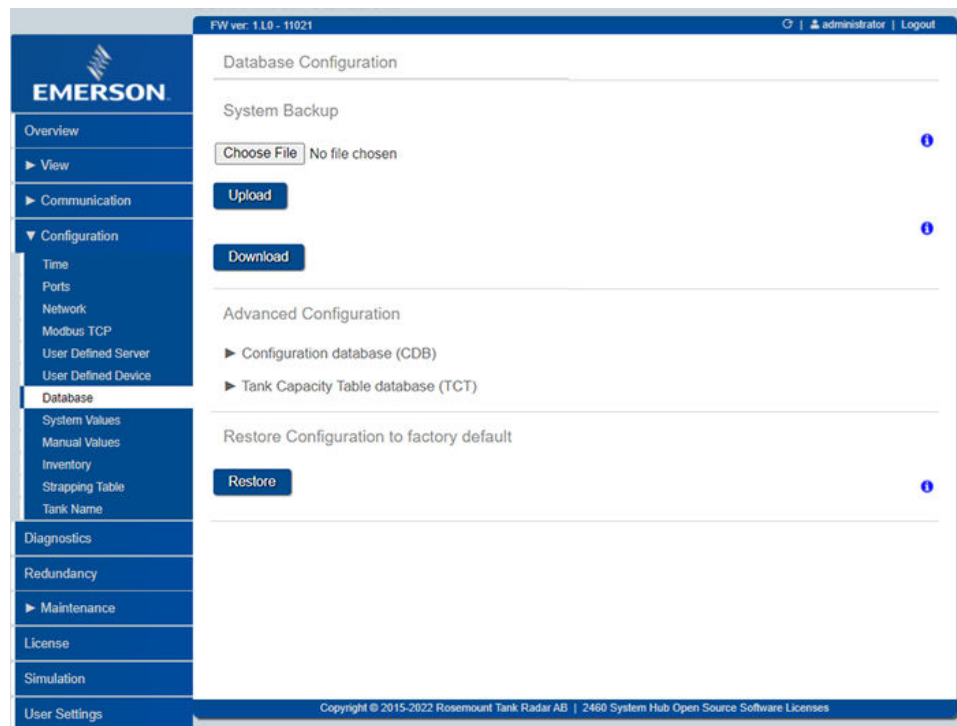

A dialog appears which prompts you to confirm the restore command.

4. Click **Cancel** in case you want to interrupt, or **Yes** to proceed with resetting the current configuration to the factory default configuration.

#### Note

Communication settings, except Modbus address and communication settings for Eth1, are restored to factory settings.

### Related information

[Create a backup of the current configuration](#)

## 6.20 Create system backup

The current Rosemount 2460 System Hub supports functionality that lets you backup configuration files, strapping tables, tank names, and registers. This is a useful option in case you, for example, need to replace a system hub. Then you can easily configure the new system hub by uploading the system backup.

### Procedure

1. Open the Web interface for the Rosemount 2460 System Hub.
2. Select menu option **Configuration** → **Database**.
3. Select the desired backup option:
  - System backup for a complete backup including database registers, Configuration Database (CDB) and Tank Capacity Table (TCT)
  - Configuration database (CDB)
  - Tank Capacity Table database (TCT)<sup>(9)</sup>
4. Select the **Download** button to store the backup file.

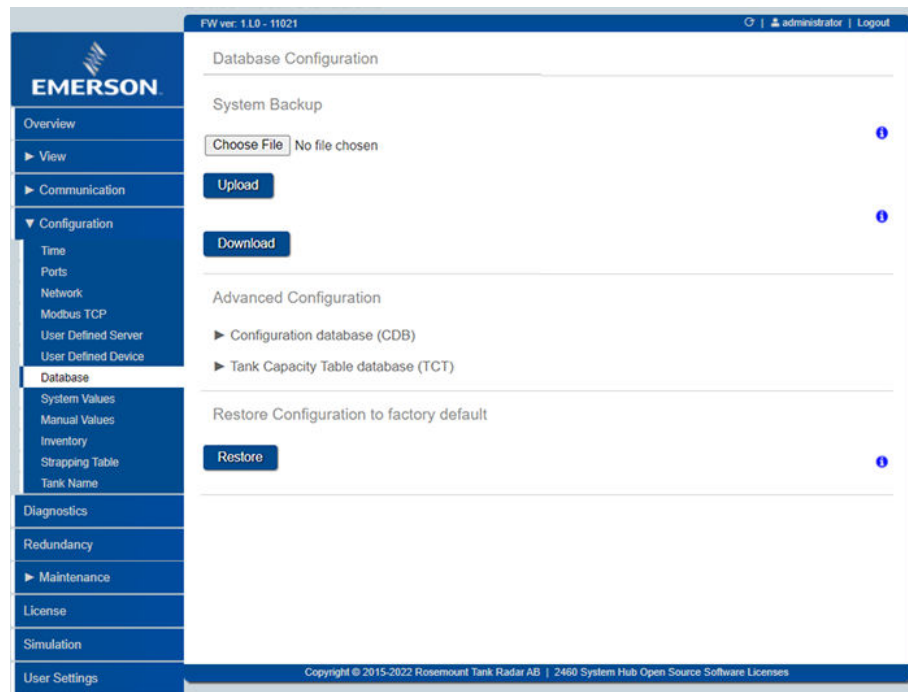

Depending on the particular web browser that is used, the backup file will be downloaded to the default folder for file downloading on the PC, or you may choose the desired destination folder.

### Note

In case the Configuration Data Base (CDB) is changed, a copy will automatically be downloaded to the SD memory card if available.

### Postrequisites

Once the database is downloaded, the file can be moved to the preferred location.

<sup>(9)</sup> Tank Capacity Table requires Inventory license.



**Related information**

[Using the web interface](#)

## 6.20.1 Database backup options

The current Rosemount 2460 System Hub lets you backup configuration files, strapping tables, and registers.

**Table 6-10: Database Backup Options**

Option	Description
System backup	Creates a complete backup of configuration files, strapping tables, and registers.
Configuration database (CDB)	Lets you create a backup copy of the configuration database (tank database) only
Tank Capacity Table (TCT) <sup>(1)</sup>	Lets you create a backup copy of the strapping table only. The strapping table is used for inventory volume calculations.

*(1) Tank Capacity Table requires Inventory license.*

## 6.20.2 Backing up a device configuration using TankMaster™

Using Rosemount TankMaster WinSetup to save the current device configuration to file:

### Procedure

1. Start the Rosemount TankMaster WinSetup program.
2. In the **TankMaster WinSetup** workspace window, right-click the device icon.
3. Choose the **Save Database to File** option.  
This option is also available from the **Service/Devices** menu.
4. Choose the desired options for **Type of Registers**, **Predefined** or **User-defined**<sup>(10)</sup>, and **Scope**. Options may vary depending on device type.

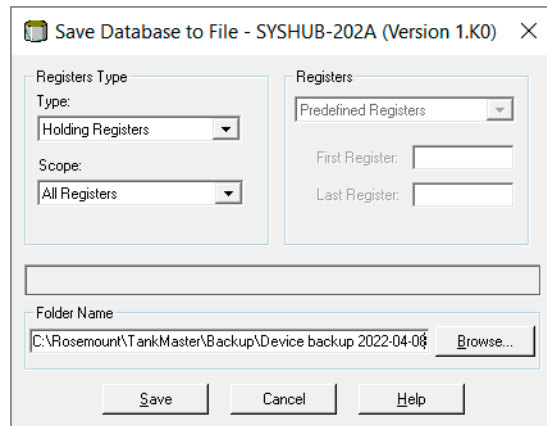

5. Click the **Browse** button, select a folder and type a name for the backup file.
6. Click the **Save** button to start saving the database registers.

<sup>(10)</sup> User-Defined should only be used for advanced service.

## 6.21 Configuration recovery

System and database configuration can be restored by uploading backup files to the Rosemount 2460 System Hub.

### Procedure

1. Open the Web interface for the Rosemount 2460 System Hub.
2. Ensure that Write Protection is disabled.  
The current status can be viewed in the **Overview** tab of the Web Interface.
3. Select **Configuration** → **Database**.
4. Select the desired option:
  - System backup
  - Configuration database (CDB)
  - Tank Capacity Table database (TCT)
5. Select the **Choose File** button and browse for the appropriate file.
6. Click the **Upload** button.

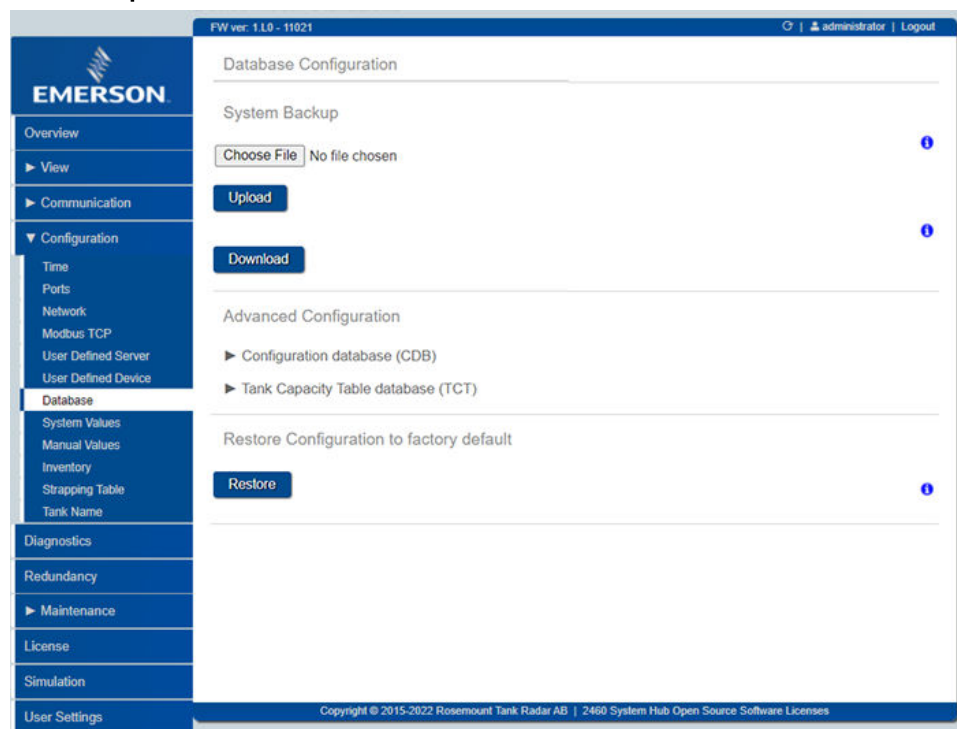

### Note

CDB files from system hubs with firmware versions later than 1.A2 must not be uploaded to a Rosemount 2460 with firmware version 1.A2.

### Related information

[Using the web interface](#)  
[Write protection](#)

## 6.21.1 Recover a backup configuration database using TankMaster™

Rosemount TankMaster WinSetup lets you replace the current Holding Register database with a backup database stored on disk. This can be useful, for example, if you want to recover lost configuration data.

### Prerequisites

#### Note

To maintain communication with the device, ensure that communication parameters in the stored backup database match the current communication settings.

### Procedure

1. In the **TankMaster WinSetup** workspace window, select the device icon.
2. Right-click and select **Upload Database**, or from the **Service** menu choose **Devices/ Upload Database**.

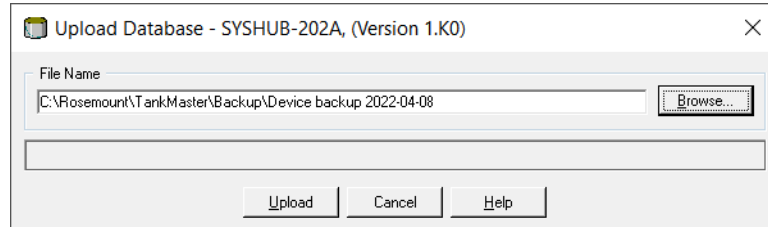

3. Click the **Browse** button and choose a database file to be uploaded, or type a path and file name.
4. Click the **Upload** button.

## 6.22 Firmware upgrade

This section describes how to upgrade the firmware of the Rosemount 2460 System Hub and field devices such as the Rosemount 2410 Tank Hub and the Rosemount 5900 Radar Level Gauge. First section covers upgrade of a single **standalone** Rosemount 2460. The second section describes how to upgrade **redundant** system hubs. The third section focuses on upgrading field device firmware.

### 6.22.1 Upgrading firmware for a single Rosemount 2460 System Hub

#### Prerequisites

##### Note

The firmware upgrade process must not be interrupted. When upgrading, do not unplug power supply or close the web browser until the process is complete. In case the upgrade process was interrupted, repeat the procedure.

##### Note

It is recommended to turn off communication logging before upgrading the system hub firmware.

#### Procedure

1. Open the Web interface for the Rosemount 2460.
2. Select the **Maintenance** → **2460 System Hub** menu option.

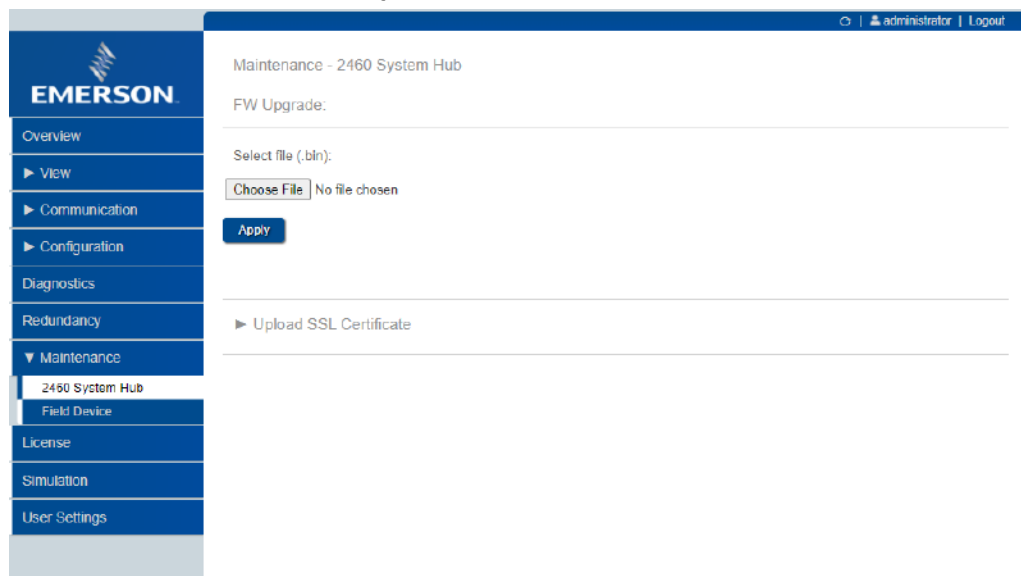

3. Click the **Browse** button and select the firmware file (file name extension .bin).

4. Click **Apply** to start the firmware upgrade.  
After pressing the **Apply** button a progress bar will be visible to indicate remaining time. When the upgrade is done, the system will switch to the log on window.

---

**Note**

Upgrading the firmware may take several minutes. The system may seem unresponsive during the upgrade but will eventually reboot and come back online. Use the refresh function in the web browser to check if the web interface is back online.

---

5. Verify that the presented firmware version is updated by opening the **Overview** tab once the firmware upgrade is completed.

**Related information**

[Using the web interface](#)

## 6.22.2 Firmware upgrade of redundant system hubs

Firmware upgrade of redundant system hubs requires a temporary change to standalone mode.

**Procedure**

1. Disable the redundancy function.
  - a) Use the Web Graphical User Interface (GUI) to verify that the Primary device is active, if not do a manual switch over.
  - b) Use Web GUI to unpair the redundant pair of system hubs.
    - Primary and Backup device will change mode to **Standalone**.
    - The Primary device will continue to poll field data.
    - The Backup device will start using default configuration database (CDB) and default Modbus address.
2. Update firmware on both devices according to the normal procedure for a Standalone system hub.
  - a) Connect to the service port **ETH3**.
  - b) Use the Web Graphical User Interface (GUI) to upgrade the firmware.

---

**Note**

The Host will lose field data when the device that polls field data is upgraded with new firmware.

---

3. Enable the redundancy function again.
  - a) Connect to the Primary device (this is the unit that has the configured database (CDB) and polls data from the field devices).
  - b) Use Web GUI to pair the redundant system hubs.  
The Primary system hub will be the Active device and continue to poll field data.

**Related information**

[Upgrading firmware for a single Rosemount 2460 System Hub](#)

## 6.22.3 Firmware upgrade of field devices

Devices such as the Rosemount 2410 and Rosemount 5900 can be reprogrammed from the **Field Device Programming** window. The process includes three steps:

1. Upload the device firmware file (.cry format).
2. Scan devices to retrieve device information.
3. Start programming selected devices.

### Upgrade field device firmware

Follow this procedure to upgrade field devices such as Rosemount 2410 and Rosemount 5900.

#### Procedure

1. Select the **Maintenance** → **Field Device** menu option.

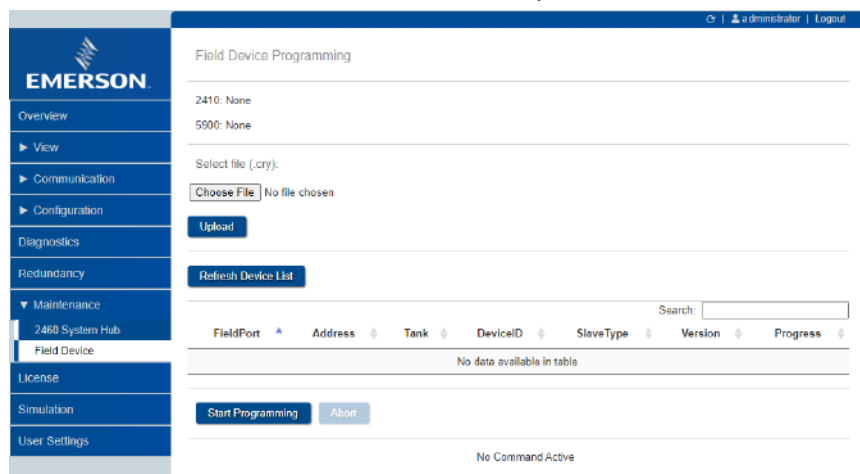

2. Select **Choose File** and locate the appropriate firmware file (.cry format).
3. Select **Upload**.  
Once a firmware file is uploaded, the firmware version of the particular device type will be displayed.

Field Device Programming

2410: 1.G7

5900: None

4. Select **Refresh Device List** to trigger device scanning.  
Device scanning shall be performed before reprogramming to get the most up to date information about devices connected to the system hub. The device scan list is cleared when the system hub is rebooted. Device scanning doesn't scan every possible address. Scanning is based on the configuration of the system hub's tank database.
5. In the resulting device list select the devices you would like to program.
6. Select **Start Programming**.  
A confirmation pop up window appears with a summary of devices to be programmed.

7. Select **Confirm** to start programming.

Reprogramming Field Devices

FieldPort ▲	Address ⇅	Tank ⇅	DeviceID ⇅	SlaveType ⇅	Version ⇅
2	156	TK-2	2274	2410 Tank Hub	1.G7
3	20	Tank 1	2188	5900 RLG	1.F0
3	120	Tank 1	10004	2410 Tank Hub	1.G7

Estimated Time: 1h 30min

**Confirm** **Cancel**

The information text is updated to indicate that reprogramming is active. It also shows a summary of how far reprogramming has progressed. The **Progress** column indicates how close to finish each device is. Devices can be in different states which are all shown in the progress column.

Search:

FieldPort ▲	Address ⇅	Tank ⇅	DeviceID ⇅	SlaveType ⇅	Version ⇅	Progress ⇅
2	56	TK-2	21348	5900 RLG	1.F0	
2	57	Tank 3	56349	5400 RLT	1.C2	
2	156	TK-2	2274	2410 Tank Hub	-	Completed
3	20	Tank 1	2188	5900 RLG	-	60%
3	120	Tank 1	10004	2410 Tank Hub	-	Pending

**Start Programming** **Abort**

Reprogramming in progress, 1/3 successful.

**Postrequisites**

When reprogramming of all devices is finished, the information text is updated to show that the devices have been successfully reprogrammed.

It is highly recommended to perform device scanning using **Refresh Device List** after programming is finished in order to get the latest information about the devices. It may take several minutes for devices to start communicating again after being reprogrammed since they will also be rebooted.



## 6.23 License upgrade

Upgrading the current license of a Rosemount 2460 requires that the system hub is in standalone mode. Prior to license upgrading, redundant system hubs must be unpaired. Both system hubs need to be upgraded.

### Related information

[Unpair redundant system hubs](#)

### 6.23.1 Upgrade procedure

To upgrade the Rosemount 2460 license:

#### Procedure

1. Open the Web Graphical User Interface (GUI).
2. Verify that the system hub is in standalone mode, otherwise unpair the devices. Once the two system hubs are upgraded you can pair them again to reset the redundant system.
3. Select the **License** menu option.
4. Expand **Order new options**.

	Current license	New license
Capacity:	64 Tanks	<input type="radio"/> 16 Tanks <input type="radio"/> 48 Tanks <input checked="" type="radio"/> 64 Tanks
Inventory:	64 Tanks	<input type="radio"/> None <input type="radio"/> 16 Tanks <input type="radio"/> 48 Tanks <input checked="" type="radio"/> 64 Tanks
Redundancy:	Yes	<input type="radio"/> No <input checked="" type="radio"/> Yes
Modbus TCP:	5 Clients	<input type="radio"/> None <input type="radio"/> 1 Client <input checked="" type="radio"/> 5 Clients
TM Modbus TCP:	None	<input checked="" type="radio"/> None <input type="radio"/> 2 Clients
User Defined Modbus:	Yes	<input type="radio"/> No <input checked="" type="radio"/> Yes
Field ports:	1 2 3 4 5 6	<input checked="" type="checkbox"/> 1 <input checked="" type="checkbox"/> 2 <input checked="" type="checkbox"/> 3 <input checked="" type="checkbox"/> 4 <input checked="" type="checkbox"/> 5 <input checked="" type="checkbox"/> 6
Host ports:	7 8	<input type="checkbox"/> 5 <input type="checkbox"/> 6 <input checked="" type="checkbox"/> 7 <input checked="" type="checkbox"/> 8
HP 7 locked to TM:	No	<input type="radio"/> No <input checked="" type="radio"/> Yes
HP 8 locked to TM:	No	<input type="radio"/> No <input checked="" type="radio"/> Yes
Demo mode:	No	<input type="radio"/> No <input checked="" type="radio"/> Yes

5. Under **New license** choose the desired options.

- Click the **Generate** button. A report is generated with the current license information.

▼ Order new Options

	Current license	New license
Capacity:	64 Tanks	<input type="radio"/> 16 Tanks <input type="radio"/> 48 Tanks <input checked="" type="radio"/> 64 Tanks
Inventory:	64 Tanks	<input type="radio"/> None <input type="radio"/> 16 Tanks <input type="radio"/> 48 Tanks <input checked="" type="radio"/> 64 Tanks
Redundancy:	Yes	<input type="radio"/> No <input checked="" type="radio"/> Yes
Modbus TCP:	5 Clients	<input type="radio"/> None <input type="radio"/> 1 Client <input checked="" type="radio"/> 5 Clients
TM Modbus TCP:	None	<input checked="" type="radio"/> None <input type="radio"/> 2 Clients
User Defined Modbus:	Yes	<input type="radio"/> No <input checked="" type="radio"/> Yes
Field ports:	1 2 3 4 5 6	<input checked="" type="checkbox"/> 1 <input checked="" type="checkbox"/> 2 <input checked="" type="checkbox"/> 3 <input checked="" type="checkbox"/> 4 <input checked="" type="checkbox"/> 5 <input checked="" type="checkbox"/> 6
Host ports:	7 8	<input type="checkbox"/> 5 <input type="checkbox"/> 6 <input checked="" type="checkbox"/> 7 <input checked="" type="checkbox"/> 8
HP 7 locked to TM:	No	<input type="radio"/> No <input checked="" type="radio"/> Yes
HP 8 locked to TM:	No	<input checked="" type="radio"/> No <input type="radio"/> Yes
Demo mode:	No	<input checked="" type="radio"/> No <input type="radio"/> Yes

**Generate**

Generated license info:

```
System name: 2460 System Hub
Firmware version: 1.00
Device ID: 1520000602
Operating hours: 32196
-----
Current license key: W5GB-TC5Q-NJ63-26X2-F7KY-
VEGR-EJTT-KM7C
-----
```

Please copy and paste in e-mail or save as [file](#)

- Copy the generated license info. Paste it into an e-mail and send to Emerson Automation Solutions to order a new license.  
Emerson Automation Solutions will reply with an e-mail including a new license key.
- Expand **Apply new license key**.
- Apply the new license key by one of the following methods:
  - Copy the new license key and paste it into the text input field.
  - Type it in manually.
  - In case the license key is stored on disk, browse to the folder where it is stored, select the license key file, and click **OK**.
- Click the **Verify Key** button.

▼ Apply new license key

Select license key file:  **Browse...**

-- OR --

Manually enter new license key:

**Verify key**

11. Once the license key is properly verified, click the **Apply new license** button to download the new license key to the system hub. It is recommended that the system hub is restarted after the license key has been downloaded (the Rosemount 2460 will automatically restart the firmware in any case).
12. In case of a redundant system, repeat the upgrade procedure for the second system hub.
13. Once both system hubs are upgraded, select the **Redundancy** menu option and pair the Primary and Backup system hubs.

#### Related information

[Using the web interface](#)

[Unpair redundant system hubs](#)

[Pairing two system hubs](#)

## 6.23.2 Demo license

You may use is a demo license that is valid for 30 days.

This option may be useful to evaluate new options before actually upgrading to a new license.

Once a demo license has been installed, the remaining time of the demo features will be visible in the license page under **Demo mode**.

## 6.24 Redundancy

The Redundancy tab lets you pair two Rosemount 2460 System Hubs. Once paired, the system hubs can be configured for redundancy operation.

### Related information

[Redundancy setup via Web graphical user interface](#)

### 6.24.1 Pairing two system hubs

#### Procedure

1. Open the Web Graphical User Interface (GUI).
2. Select the **Redundancy** menu option.
3. Expand the **Pair** option and verify that a green symbol indicates that the two devices can be paired.

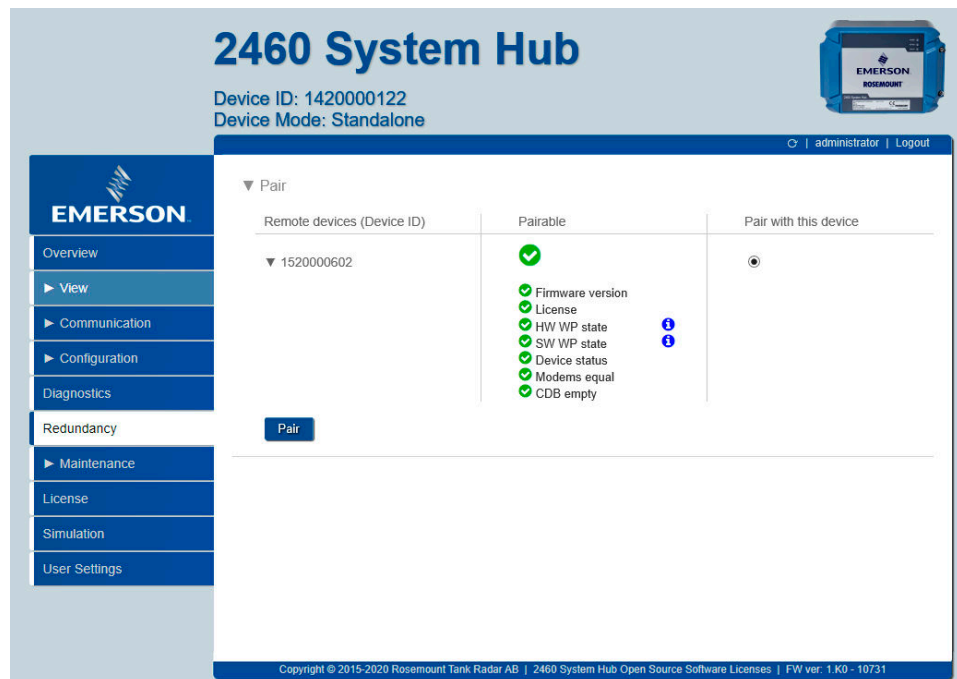

4. Click the **Pair** button.

5. Verify that the redundant system hubs are successfully paired and changed to redundancy mode.

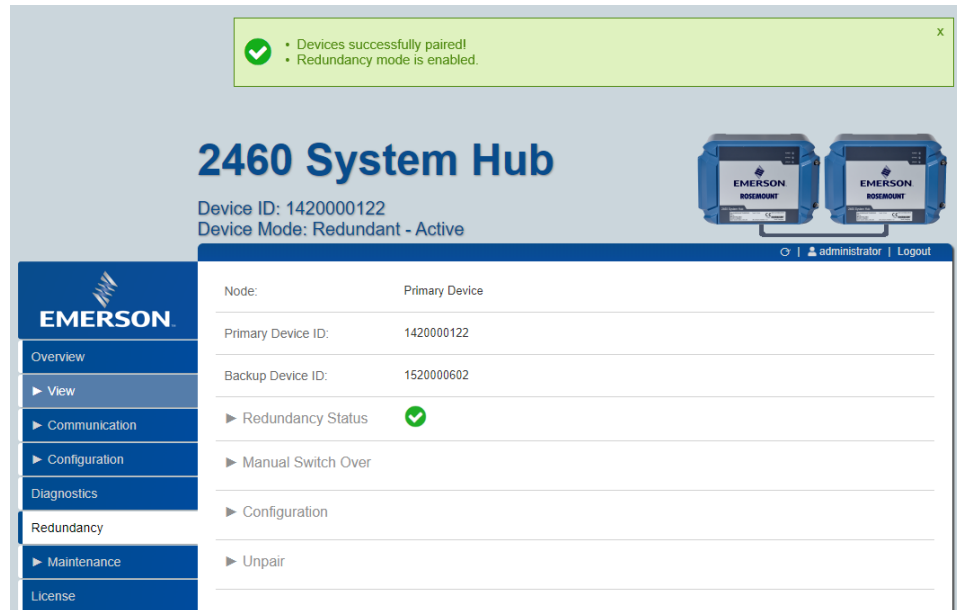

#### Related information

[Using the web interface](#)

## 6.24.2 Unpair redundant system hubs

### Procedure

1. Open the Web Graphical User Interface (GUI).
2. Select the **Redundancy** menu option.

- Expand the **Unpair** option and verify that a green symbol indicates that the Primary and Backup devices can be unpaired.

The screenshot displays the '2460 System Hub' web interface. At the top, it shows 'Device ID: 1420000122' and 'Device Mode: Redundant - Active'. A navigation sidebar on the left includes options like Overview, View, Communication, Configuration, Diagnostics, Redundancy, Maintenance, License, Simulation, and User Settings. The main content area shows details for the Primary Device (ID: 1420000122) and Backup Device (ID: 1520000602). Under the 'Unpair' section, a table lists the remote device (ID: 1520000602) with a green checkmark indicating it is unpairable. The reasons listed are: Active SW WP state, Active HW WP state, Passive SW WP state, Passive HW WP state, and Connection state. An 'Unpair' button is visible below the table, along with a note: 'Note: The remote device configuration will be reset to default after unpair.'

- Click the **Unpair** button.
- Verify that the redundant system hubs are successfully unpaired and changed to standalone mode.

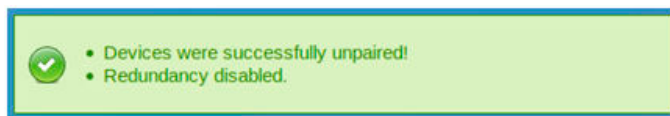

### Related information

[Using the web interface](#)

## 6.25 Fuses

Two T1.6A fuses are located on the Power Board inside the Rosemount 2460 housing. See [Figure 6-17](#).

**Figure 6-17: Two T1.6A 250V Fuses Inside the Rosemount 2460 Housing**

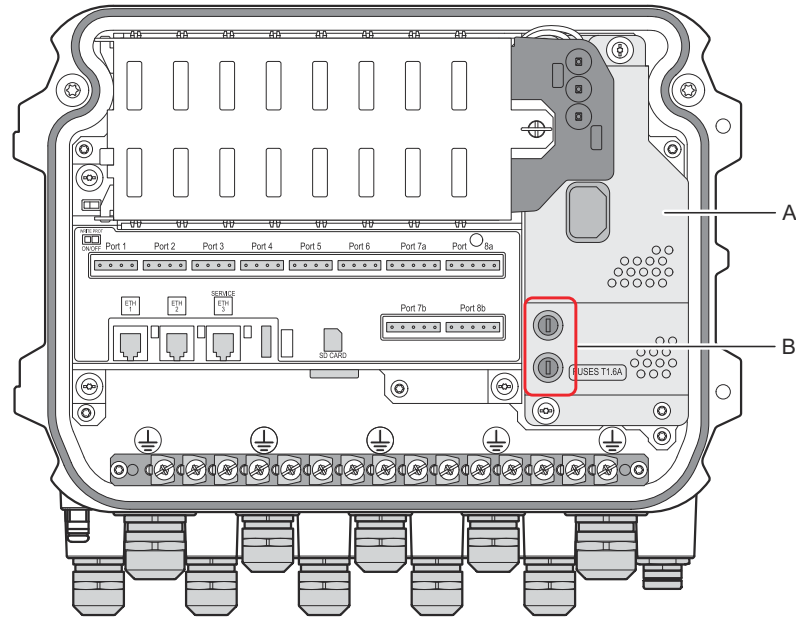

- A. Power board
- B. Fuses: 2xT1.6A 250 V

## 6.26 Write protection

The Rosemount 2460 System Hub can be write protected to prevent unauthorized changes of the configuration database.

There are two options for write protecting the Rosemount 2460:

- hardware write protection switch
- software write protection

---

### Note

In a redundant system both the Primary and Backup system hubs should be write protected.

---

### 6.26.1 Hardware write protection switch

To enable or disable the hardware write protection:

#### Procedure

1. Remove the locking screws and open the lid on the Rosemount 2460 housing.
2. Locate the Write Protection switch.
3. Set the write protection switch to the desired position **On** or **Off**.

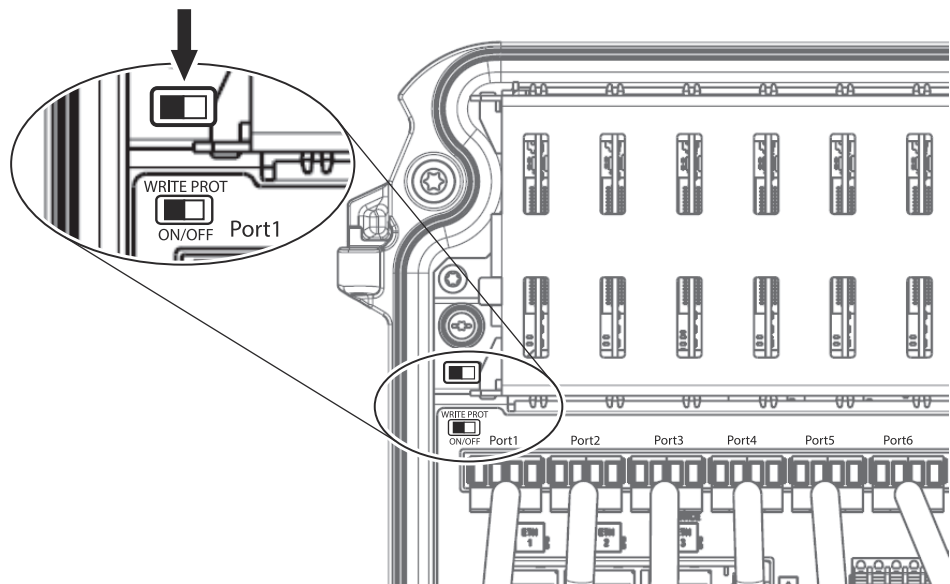

### 6.26.2 Software write protection

The current write protection status can be viewed in the Rosemount 2460 Web Interface.

#### Prerequisites

---

### Note

In case the Rosemount 2460 is hardware write protected, the current SW write protection can not be changed.

---



### Procedure

1. Open and log in to the Web Interface.
2. Select the **Overview** tab.

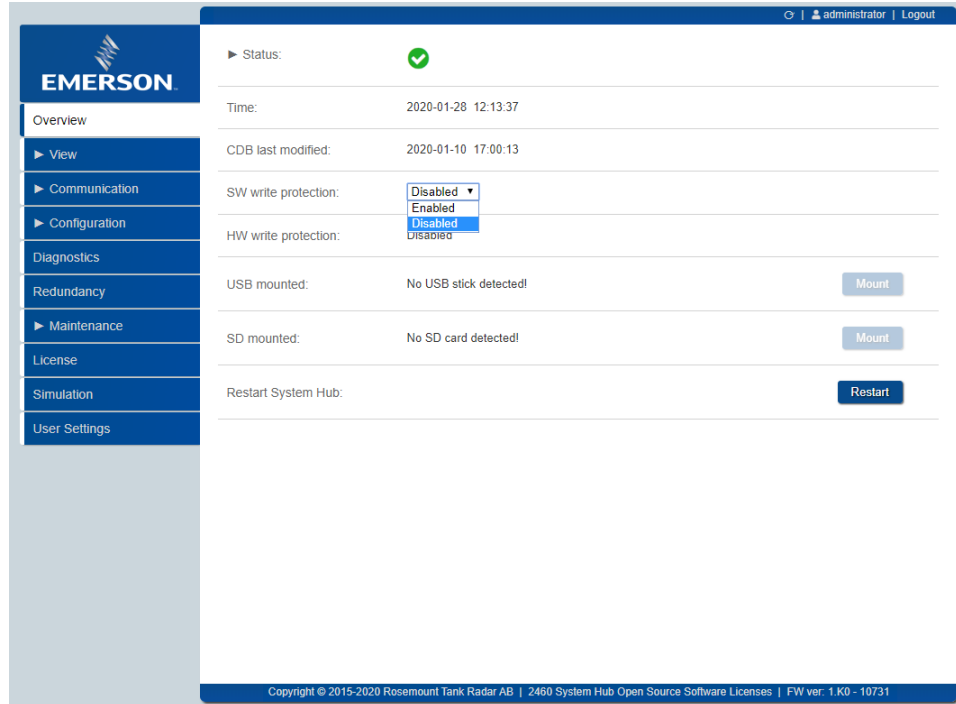

3. Enable or disable software write protection by choosing the desired option from the drop-down list.

### Related information

[Using the web interface](#)

## 6.27 Replacing the backup battery

In case a battery warning appears, you will have to change the backup battery which is located on the Main Board. To change the battery you will have to remove the Terminal Board which is stacked on top of the Main Board.

### Prerequisites

Make sure that a button battery of type **3V CR 1632 lithium** is used.

### Procedure

1. ⚠ Turn off power supply by disconnecting external switch.
2. Remove the Terminal Board as described in [Exchanging the terminal board](#).
3. Locate the Backup battery on the Main Board.

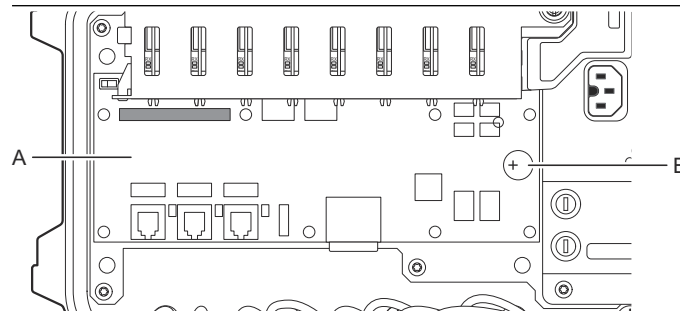

A. Main Board  
B. Backup battery

4. Replace the battery with a button battery of type **3V CR 1632 lithium**. Ensure that the battery is placed with the + side facing up.
5. Replace the Terminal Board.

### Postrequisites

Set date and time.

### Related information

[Setting the real-time clock](#)

[Exchanging the terminal board](#)

## 6.28 Setting the real-time clock

To set the Real-Time Clock:

### Procedure

1. In the **TankMaster WinSetup** workspace click the right mouse button on the Rosemount 2460 System Hub icon.

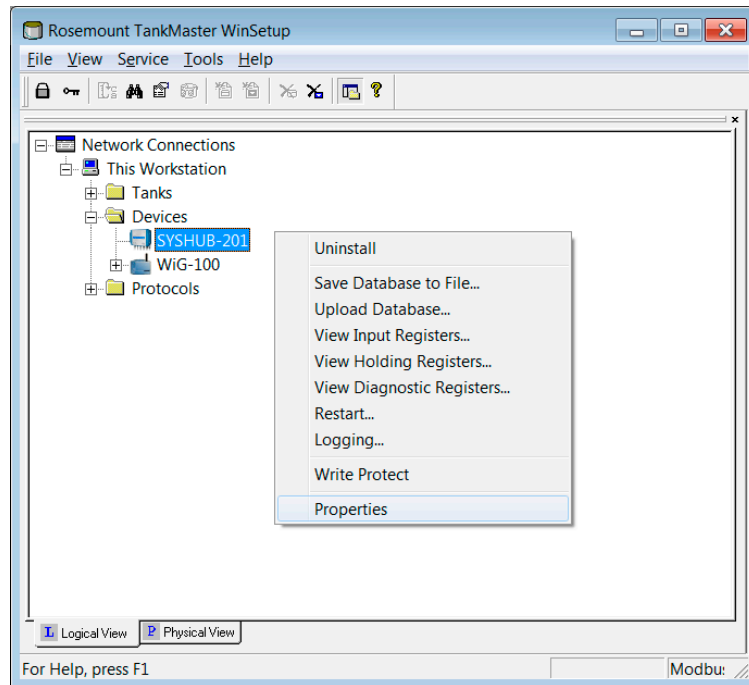

2. Click the **Properties** option.
3. Select the **Advanced** tab and click the **Real Time Clock** button.

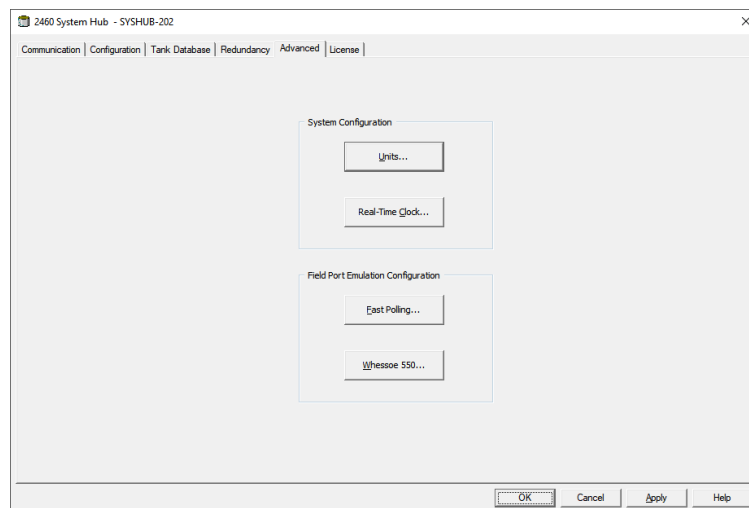

4. Choose the appropriate option for the Real-Time Clock:
  - **Enter new time** lets you specify the time manually.
  - **Use same system time ...** lets you synchronize the Rosemount 2460 clock with the TankMaster PC.

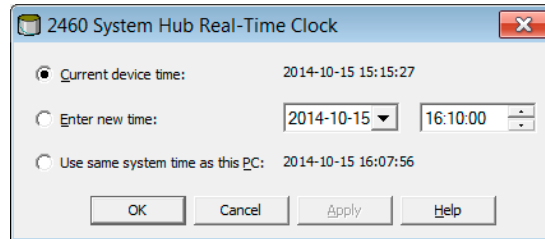

5. Click **OK** to save the configuration and close the window.

#### Related information

[Time](#)

## 6.29 Maintenance

Use a soft cloth lightly dampened in water to clean the Rosemount 2460 housing. Do not use chemical solvents.

## 6.30 Modem cards

### 6.30.1 RS232 and 485 modem cards

The RS232/485 modem card (see [Figure 6-18](#)) can be used for RS232 or RS485 communication. Four switches are available to configure the card as specified in [Table 6-11](#).

In case the card is configured for RS485 communication, the terminator must be activated (ON) when the Rosemount 2460 is the last device on the bus.

**Table 6-11: Configuration Switches**

Switch	Description
S1	RS-485 and RS-232 <sup>(1)</sup> selection
S2	RS-485 operation mode Half/Full Duplex
S3 <sup>(2)</sup>	RS-485 termination ON/OFF (High side)
S4 <sup>(2)</sup>	RS-485 termination ON/OFF (Low side)

- (1) When using the RS-232 interface the RS-485 termination switches (S3 and S4) must be in OFF state.  
 (2) Both S3 and S4 must be in ON or OFF state for proper termination or no termination.

#### Note

Both the switches must be either ON or OFF position for proper operation and indication.

#### RS-232

**Table 6-12: Configuration Switches when using RS-232 Communication**

Switch	RS-232 communication
S1	RS-232 (ON)
S2	(not applicable for RS-232)
S3 <sup>(1)</sup>	OFF (RS-485 termination High side)
S4 <sup>(1)</sup>	OFF (RS-485 termination Low side)

- (1) When using the RS-232 interface the RS-485 termination switches (S3 and S4) must be in OFF state.

#### RS-485

**Table 6-13: Configuration Switches when using RS-485 Communication**

Switch	RS-232 communication
S1	RS-485 (OFF)
S2	RS-485 operation mode Half/Full Duplex
S3 <sup>(1)</sup>	RS-485 termination ON/OFF (High side)
S4 <sup>(1)</sup>	RS-485 termination ON/OFF (Low side)

- (1) Both S3 and S4 must be in ON or OFF state for proper termination or no termination.

Figure 6-18: Modem Card for RS232 and RS485

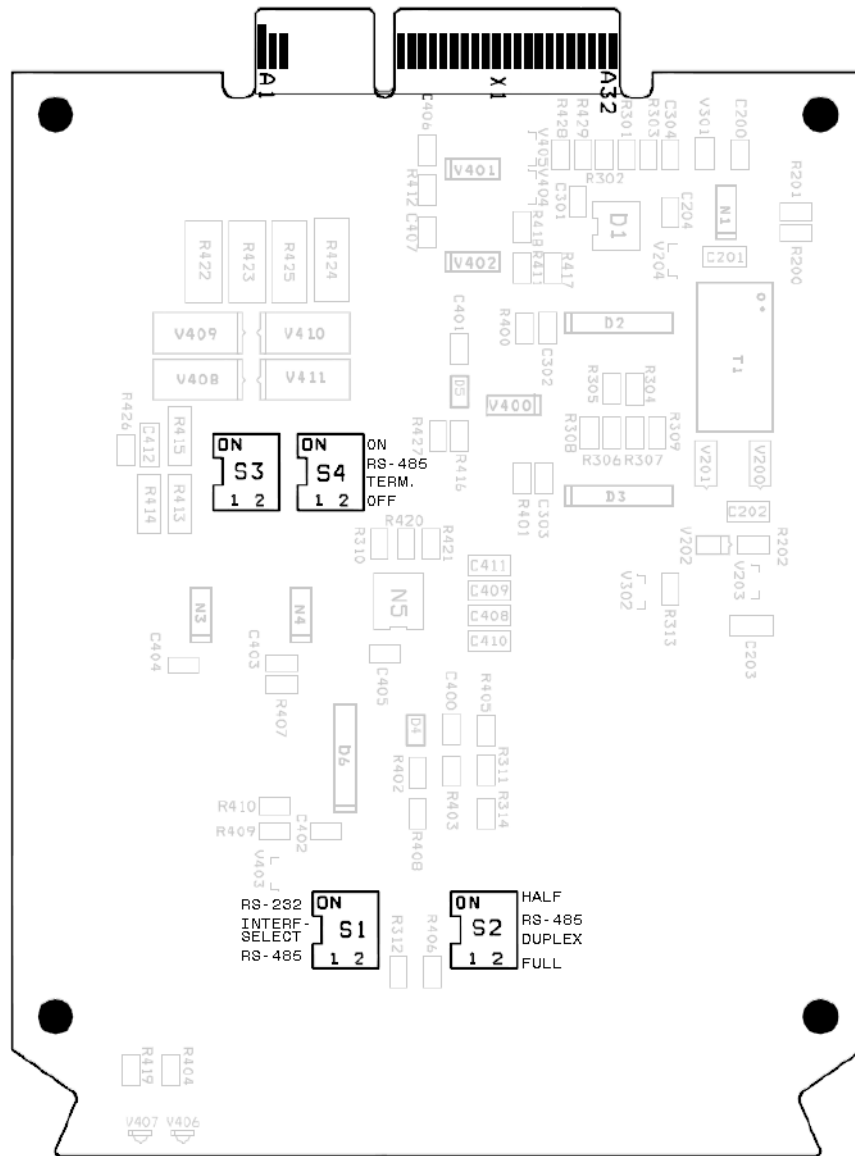

### 6.30.2 Enraf® modem card

The Enraf modem has a switch (S3) that allows you to set the Baud Rate to 1200, 2400, or 4800. The proper setting depends on what is supported by the connected field devices. 1200 is the standard setting.

Figure 6-19: Enraf Modem Card

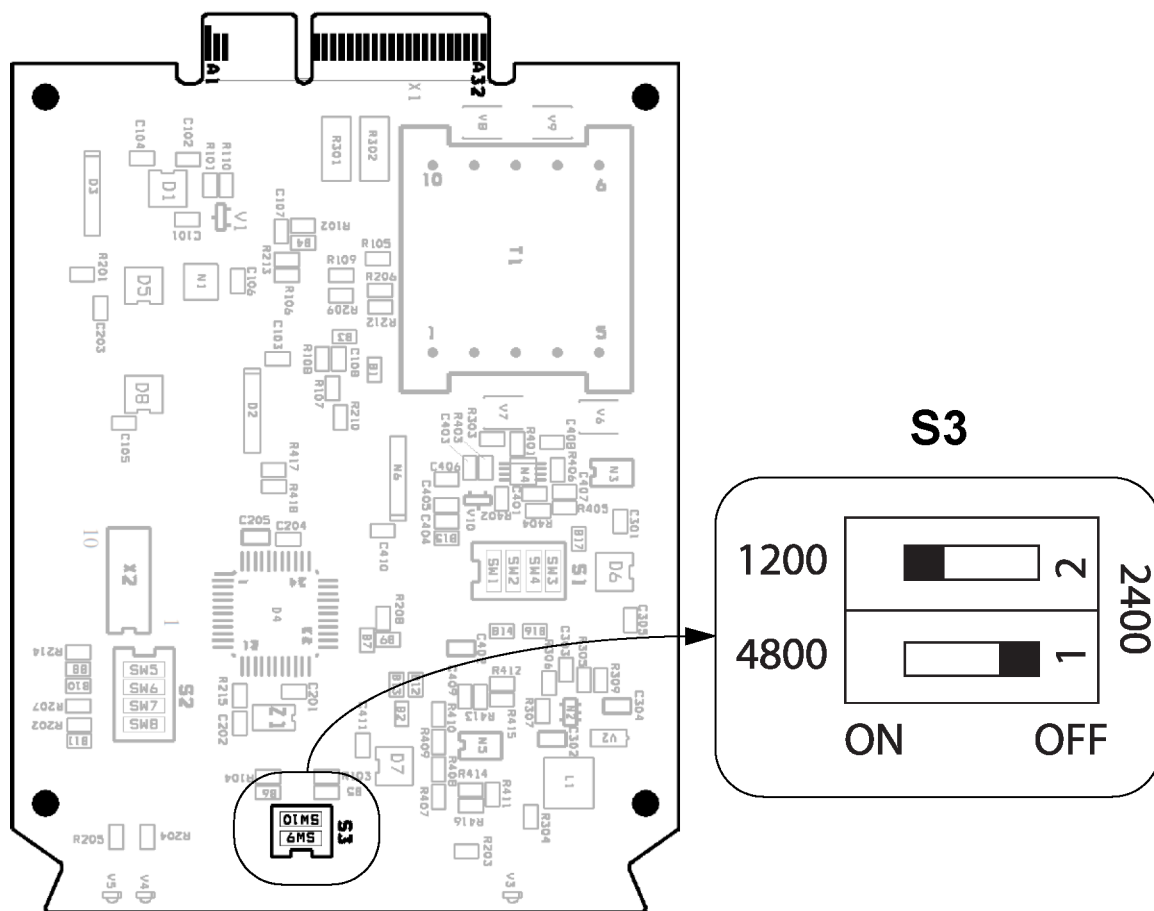

Table 6-14: Configuration of Switch S3 for Enraf Modem

Baud Rate	1	2
1200 <sup>(1)</sup>	OFF	ON
2400	OFF	OFF
4800	ON	OFF

(1) Standard setting

### 6.30.3 L&J modem card

Figure 6-20: L&J Modem Card

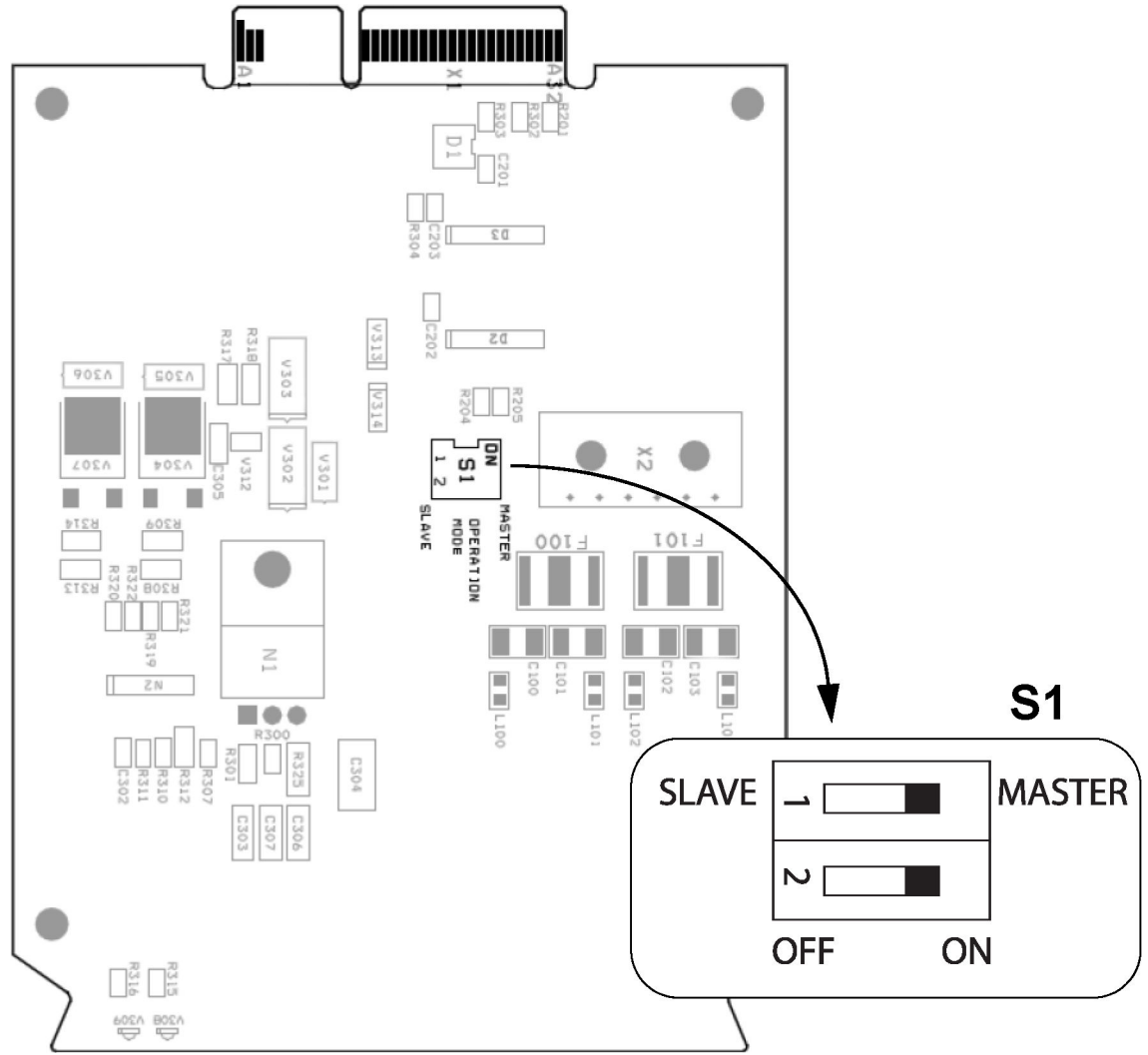

Table 6-15: Configuration Switches

Switch	Description
S1	L&J Master/Slave operation.

Table 6-16: Configuration of Switch S1 for L&J Modem

Mode	1	2
Master	ON	ON
Slave	OFF	OFF

Ensure that switch S1 is set in **Master** position for Rosemount 2460 field ports.



### 6.30.4 Varec modem card

Figure 6-21: Varec Modem Card

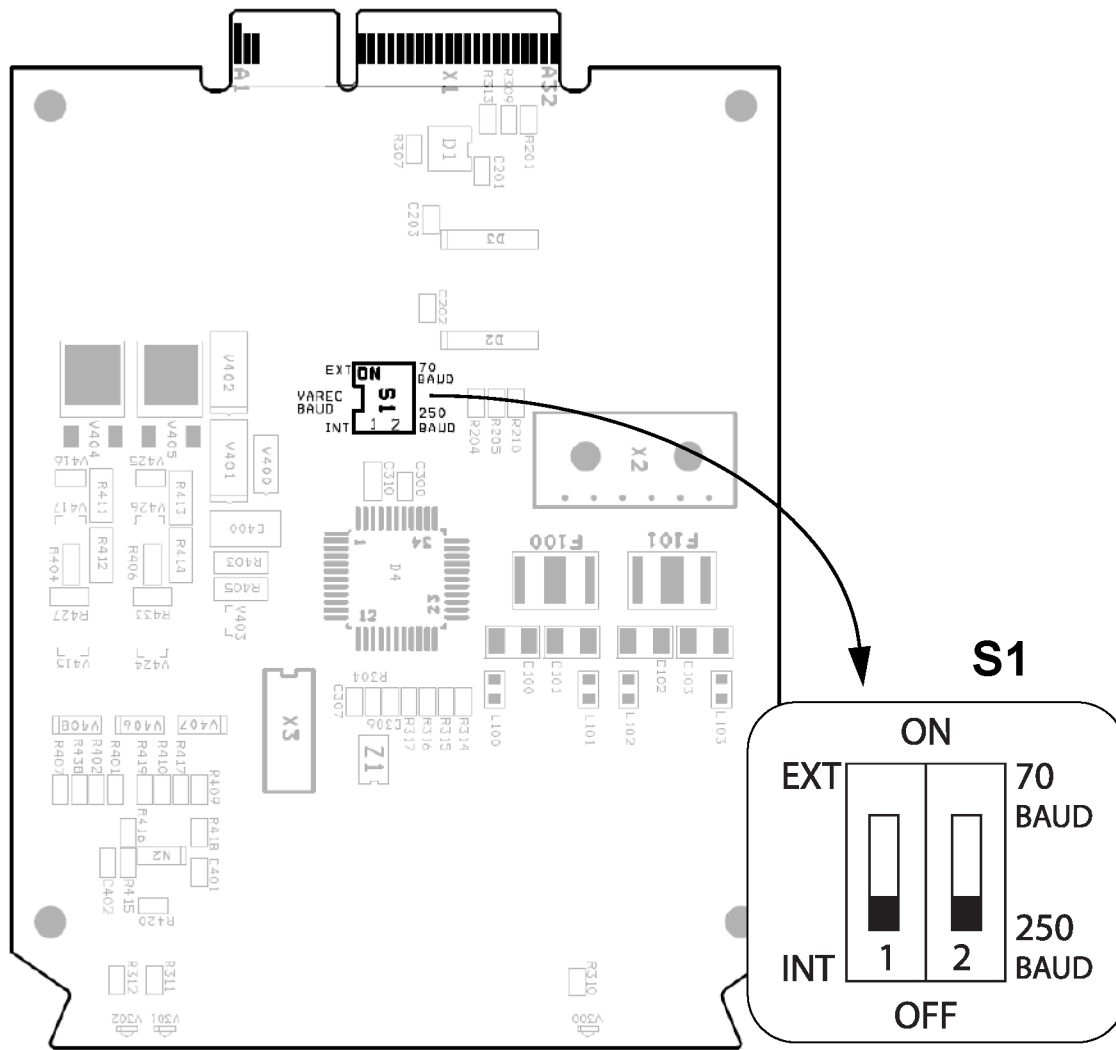

Table 6-17: Configuration Switches

Switch	Description
S1:1	Varec baud rate selection externally (via local host) or internally (via DIP switch)
S1:2	Varec baud rate selection 250/70 baud. Active only if S1:1 is OFF (INT).

Table 6-18: Standard Configuration for Internal Baud Rate Control via DIP Switch S1

Baud rate	1	2
70	OFF (INT)	ON
250	OFF (INT)	OFF







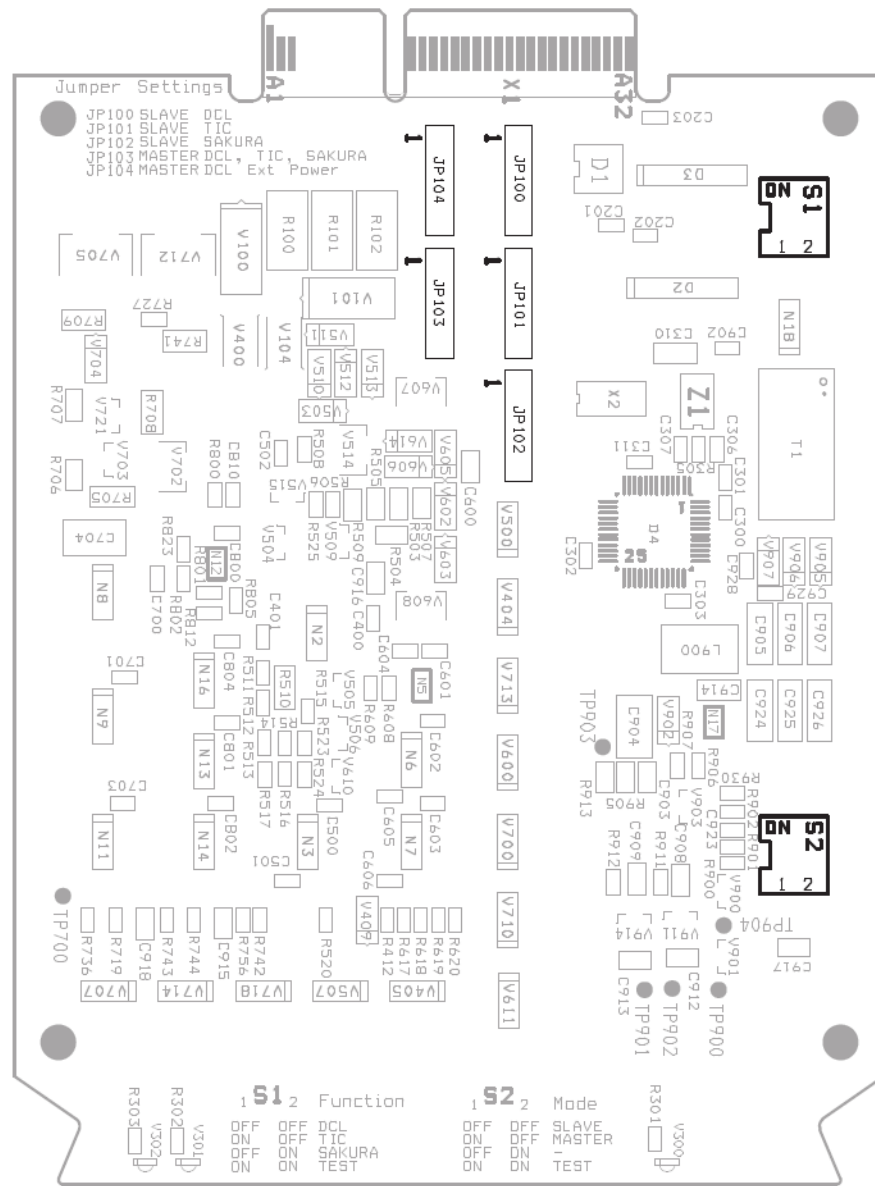



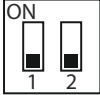
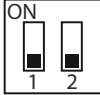

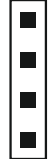

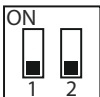
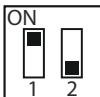

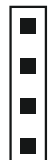



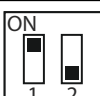

### 6.30.5 Modem Multi Loop

The Modem Multi Loop (MML) card has five jumpers JP100 - JP104 and two switches S1 and S2 which are configured for the respective electrical interface. See [Table 6-19](#).

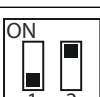
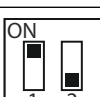
**Figure 6-22: MML Modem Card**



**Table 6-19: Switch and Jumper Settings**

Electrical Interface	S1	S2	JP100	JP101	JP102	JP103	JP104
Digital Current Loop (Whessoe/GPE) External power supply							
Digital Current Loop (Whessoe/GPE) Internal power supply							
Tokyo Keiso (TIC)							
Sakura							

## 6.31 Simulation

The **Simulation** option lets you simulate tanks and parameter values. You may simulate fixed values or values that change over time.

Figure 6-23: Simulation

Table 6-20: Simulation Options

Option	Description
Simulation mode	<b>Single</b> tank or <b>All</b> tanks
Tank	For simulation mode <b>Single</b> you have to select which tank to simulate
Function mode	Static or Ramp & Noise
Simulation time	Duration can be set up to 60 minutes. Set Duration to zero (0) if you like to control duration with the <b>Stop</b> button. In this case simulation is active until stopped manually.
Parameters	Tank parameters such as Level, Level rate, Ullage, Free Water Level, Vapor Temperature, Product Temperature, Vapor Pressure, and Product Pressure

Function mode **Static** means that parameter values will be used as specified in the table. For **Simulation Mode=All Tanks** the offset value will be added from one tank to the other.

Function mode **Ramp & Noise** means that **Level** and **Ullage** are controlled by the simulated **Level Rate** value. **Level Rate** is used to calculate movement of both **Level** and **Ullage**. Values will change direction when the tank is full or empty<sup>(11)</sup>.

Noise is applied to all other values as a random integer number from -3 to 3. This number will be multiplied with the **Offset** value and applied to the simulated parameter.

**Parameters** that can be simulated:

- Level
- Level rate
- Ullage
- Free Water Level
- Vapor Temperature
- Product Temperature
- Vapor Pressure
- Product Pressure

## 6.31.1 Simulation messages

Examples of messages that may appear when you start simulation.

### Single tank

Simulation of a single tank:

```
2460 System Hub Simulation:
```

```
All values from TK-001A in 2460 System Hub will be simulated!
```

```
Do you want to proceed?
```

### All tanks

Simulation of all tanks:

```
2460 System Hub Simulation:
```

```
All values from all tanks in 2460 System Hub will be simulated!
```

```
Do you want to proceed?
```

### Configuration

Simulation configuration has not been applied:

```
Apply new configuration before starting simulation!
```

---

(11) Tank Height is defined as the sum of simulated values for Level and Ullage.



# A Specifications and reference data

## A.1 Communication/configuration specifications

### A.1.1 Number of tanks

Each Rosemount 2460 can be configured for up to 64 tanks. The actual number of tanks depends on the electrical interface and field port configuration. For more information, see [Table A-1](#).

Note that each Rosemount 5900S Radar Level Gauge with 2-in-1 functionality corresponds to two tanks.

### A.1.2 Number of devices per field port

[Table A-1](#) lists the maximum number of devices that can be connected to each Rosemount 2460 field port. Examples of devices are Rosemount 2410, Rosemount TankRadar Pro, and legacy devices, such as Rosemount TankRadar Rex and Rosemount TankRadar TRL2.

**Table A-1: Number of Devices**

Interface	Maximum number of devices connected to each field port
RS485 <sup>(1)</sup>	16
TRL2 <sup>(2)</sup>	8
Enraf BPM	10
Digital Current Loop 0-20 mA (DCL) <sup>(3)</sup>	10 <sup>(4)</sup>
L&J	10 <sup>(5)</sup>
Varec	10 <sup>(5)</sup>

(1) Devices such as E+H NRF590 Tank Side Monitor (TSM), devices using TSM Modbus mapping, Whessoe, GPE, SI-6290/7000, Wärtsilä 1146, and user-defined Modbus devices are supported.

(2) Devices such as Rosemount 2410 Tank Hub, Rosemount TankRadar Rex, Rosemount TankRadar Pro, TRL2 gauges, and DAU are supported.

(3) Devices such as Whessoe and GPE are supported.

(4) Up to 32 devices are supported when using external power.

(5) In certain situations, more than 10 devices may work. Contact Emerson Automation Solutions/Tank Gauging Service Department for advice.

## A.1.3 Number of ports

**Table A-2: Number of Interface Ports**

Interface	Number of ports
Modem <sup>(1)</sup>	8
Ethernet <sup>(2)</sup>	3
USB <sup>(2)</sup>	1
SD <sup>(2)</sup>	1

(1) For more information, see [Table A-4](#) and [Table A-3](#).

(2) For more information, see [Table A-6](#).

Modem ports can be configured for either field or host communication according to the model code. For more information, see [Table A-5](#).

## A.1.4 Hosts

See [Table A-4](#) and [Table A-5](#).

## A.1.5 Rosemount 2160/2165 emulation

Host protocol, supporting the Rosemount 2160/2165 Field Communication Unit input register mapping. Enables the replacement of Rosemount 2160/2165 without re-programming the host. The maximum number of tanks is reduced to 32 when using 2160 emulation.

## A.1.6 Digital communication protocols

**Table A-3: Serial Field Communication Ports (1-6)**

Supported devices	Protocol	Electrical interface	Baud rate	Port
Rosemount 2410, TankRadar Rex gauges (with SDAU), IDAU, TankRadar Pro, and TankRadar TRL2 gauges	Modbus RTU	TRL2	4800	1-6
Rosemount 2410		RS485 (2-wire)	150-38400	
Enraf 811, 813, 854, 873, 877, 894, 970, 971, 973, and TOI-B <sup>(1)</sup>	GPU	Enraf Bi-phase Mark	1200/2400	
GPE 31422, 31423	GPE	20 mA Digital Current Loop	150-2400	
		RS485	150-38400	
Whessoe 1315, 1143	WM 550	20 mA Digital Current Loop	150-2400	
	WM 660	20 mA Digital Current Loop	150-2400	
		RS485	150-38400	



**Table A-3: Serial Field Communication Ports (1-6) (continued)**

Supported devices	Protocol	Electrical interface	Baud rate	Port
L&J 1500 XL, MCG 2000, L&J MCG 1600	L&J Tankway	L&J Tankway	300-4800	
Varec 1800, 1900	Varec Mark/Space	Varec Mark/Space	70/250	
E+H NRF590 Tank Side Monitor	Modbus	RS485	150-38400	
User-defined Modbus devices <sup>(2)</sup>				
LTD (Level, Temperature, Density) SI 6290/7000				
LTD (Level, Temperature, Density) Whessoe/Wärtsilä 1146				
Tokyo Keiso	Tokyo Keiso	Tokyo Keiso	2400	
Sakura	Sakura V1 Sakura MDP	Sakura	2400	

- (1) Enraf 990 uses TOI-B for measurement data.
- (2) Fully configurable up to three device types.

**Table A-4: Host Communication Ports (5-8)**

Supported devices	Protocol	Electrical interface	Baud rate	Port
TankMaster	Modbus RTU	TRL2	4800	5-8
		RS485 (2-wire)	150-38400	5-8 <sup>(1)</sup>
		RS485 4-wire)		7-8 <sup>(1)</sup>
		RS232		7-8
	Modbus TCP	Ethernet	N/A	Eth1
Other hosts (DCS, SCADA etc.)	Modbus RTU	TRL2	4800	5-7
		RS485 (2-wire)	150-38400	5-7 <sup>(1)</sup>
		RS485 (4-wire)		7 <sup>(1)</sup>
		RS232		7
Enraf CIU 858 emulation <sup>(2)</sup>	GPU	RS485 (2-wire)	150-38400	5-7 <sup>(1)</sup>
		RS485 (4-wire)		7 <sup>(1)</sup>
		RS232		7

- (1) Configurable termination by hardware switch.
- (2) One Rosemount 2460 can replace multiple Enraf CIU 858 devices by replying to more than one separate addresses.

**Table A-5: Port Configuration Options**

Ports	1	2	3	4	5	6	7	8
Alternative 6+2 (standard)	Field Port	Field Port	Field Port	Field Port	Field Port	Field Port	Host Port	Host Port
Alternative 5+3	Field Port	Field Port	Field Port	Field Port	Field Port	Host Port	Host Port	Host Port
Alternative 4+4	Field Port	Field Port	Field Port	Field Port	Host Port	Host Port	Host Port	Host Port

**Table A-6: Additional Interfaces**

Electrical interface	Description
Ethernet 1 (ETH 1) <sup>(1)(2)</sup>	Modbus TCP connection to host system
Ethernet 2 (ETH 2) <sup>(2)</sup>	Connected to redundant system hub
Ethernet 3 (ETH 3) <sup>(2)</sup>	Used for accessing the web interface via a web browser for advanced configuration and service
USB 2.0 <sup>(3)</sup>	USB memory stick for logging diagnostic data
SD <sup>(3)</sup>	SD card for logging diagnostic data

- (1) When connecting the system hub to the local LAN network, make sure the connection is secure to prevent unauthorized access.
- (2) CAT 5 or 6 cable is recommended.
- (3) FAT32 file system.

**Figure A-1: Typical Configuration of a Rosemount 2460 System Hub**

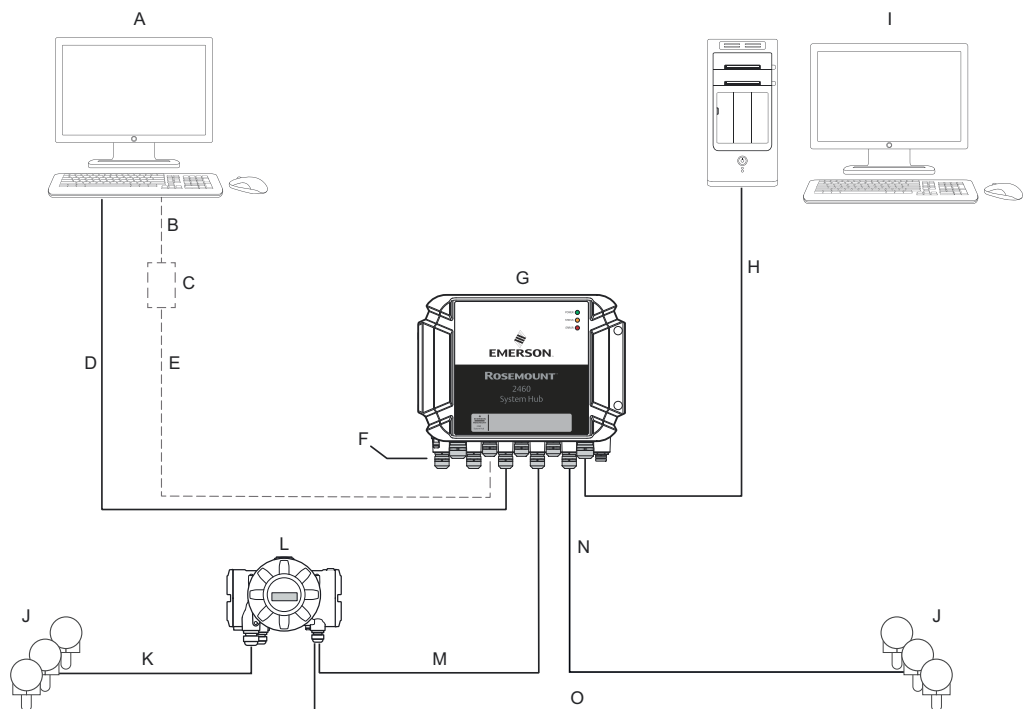

- A. TankMaster™
- B. USB, RS232
- C. Modem
- D. Ethernet (Modbus® TCP), RS232, RS485
- E. TRL2, RS485
- F. Host and Field ports
- G. Rosemount 2460 System Hub
- H. Ethernet (Modbus® TCP), TRL2, RS232, RS485
- I. Other hosts
- J. Field devices
- K. Tankbus
- L. Rosemount 2410 Tank Hub
- M. Primary bus: TRL2, RS485
- N. TRL2, RS485, other vendors
- O. Secondary bus: Enraf®, Whessoe and others, HART® 4-20 mA analog output/input

**Figure A-2: Typical Redundant Configuration**

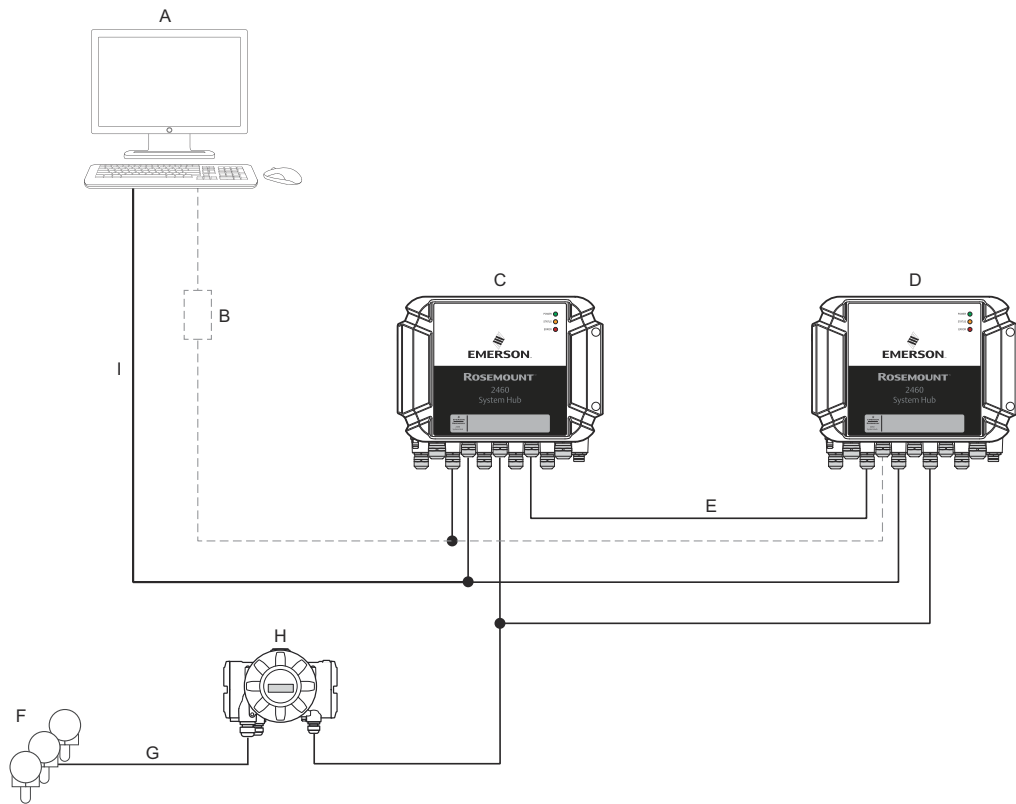

- A. TankMaster
- B. Modem
- C. Rosemount 2460 System Hub, primary
- D. Rosemount 2460 System Hub, secondary
- E. Redundancy control signal
- F. Field devices
- G. Tankbus
- H. Rosemount 2410 Tank Hub
- I. Ethernet (Modbus TCP), RS232, RS485

## A.2 Electrical specifications

### A.2.1 Power supply

24-48 VDC (-15%, +10%)  
100-250 VAC (-15%, +10%), 50/60 Hz ( $\pm 2\%$ )

### A.2.2 Power consumption

Maximum 20 W

### A.2.3 Cable entries

Nine M20 x 1.5 (female thread)  
Two M25 x 1.5 (female thread)

### A.2.4 Electrical interface

See [Table A-4](#), [Table A-3](#) and [Table A-6](#).

### A.2.5 Cable size

Power: 0.75 to 2.1 mm<sup>2</sup> (18-14 AWG)  
Bus: 0.5 to 2.5 mm<sup>2</sup> (20-14 AWG) depending on communication interface

### A.2.6 Built-in mains fuses

T1.6 A

### A.2.7 Backup battery

3V CR 1632 lithium

## A.3 Mechanical specifications

### A.3.1 Housing material

Polyurethane-covered die-cast aluminum

### A.3.2 Installation

Wall mounted by four screws. For more information, see [Dimensional drawings](#).

### A.3.3 Weight

7 kg (15 lbs)

## A.4 Environmental specifications

### A.4.1 Temperature limits

**Ambient temperature**

-40 to 70 °C (-40 to 158 °F)

**Storage temperature**

-40 to 80 °C (-40 to 176 °F)

### A.4.2 Humidity limits

0-100% relative humidity

### A.4.3 Ingress protection

IP 65

## A.5 Additional specifications

### A.5.1 Metrology sealing possibility

Yes

### A.5.2 Write protection

Yes, via software configuration and/or hardware switch.

### A.5.3 Transient/built-in lightning protection

The field data ports are in accordance with IEC 61000-4-5, level 1kV line to ground.

## A.6 Dimensional drawings

Figure A-3: Rosemount 2460 System Hub

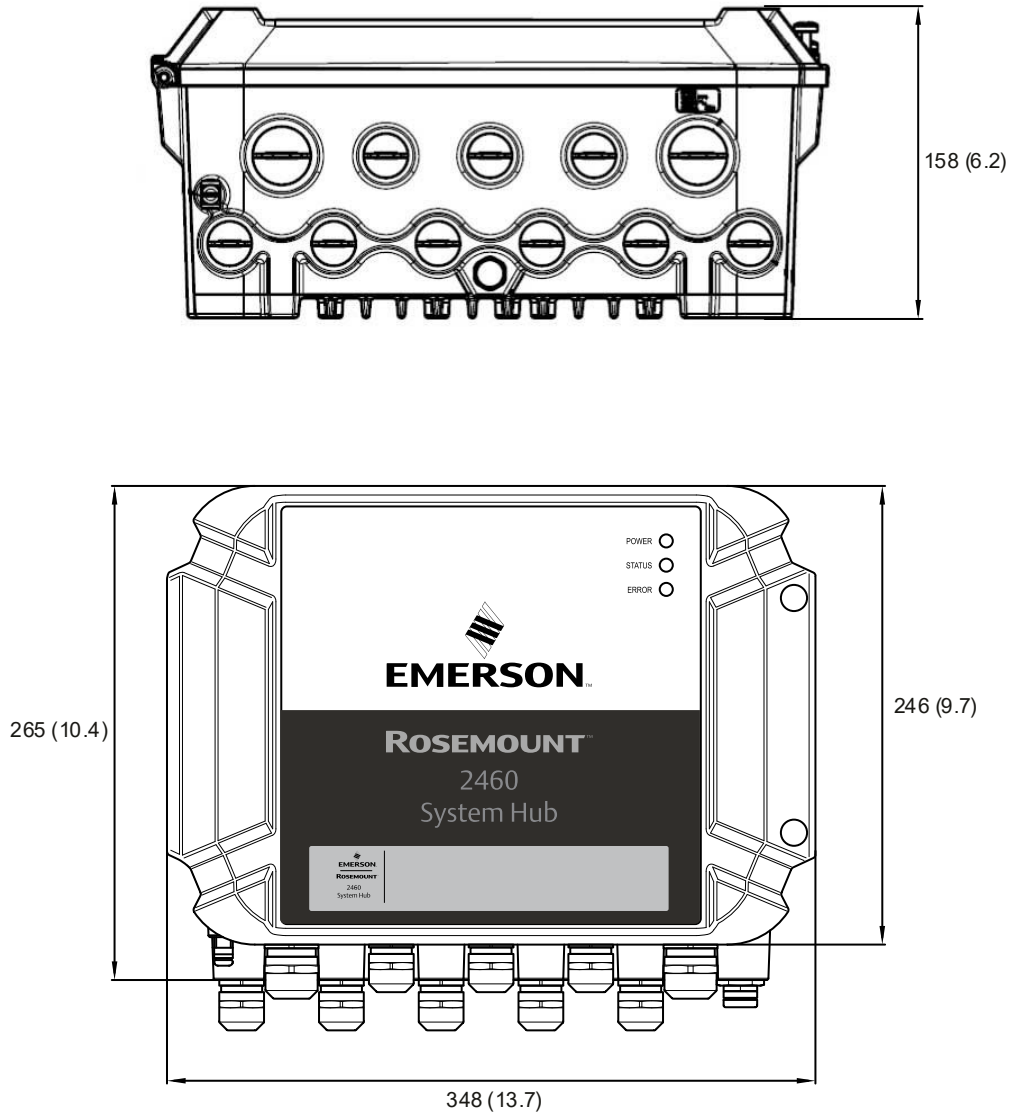

Dimensions are in millimeters (inches).

Figure A-4: Rosemount 2460 System Hub

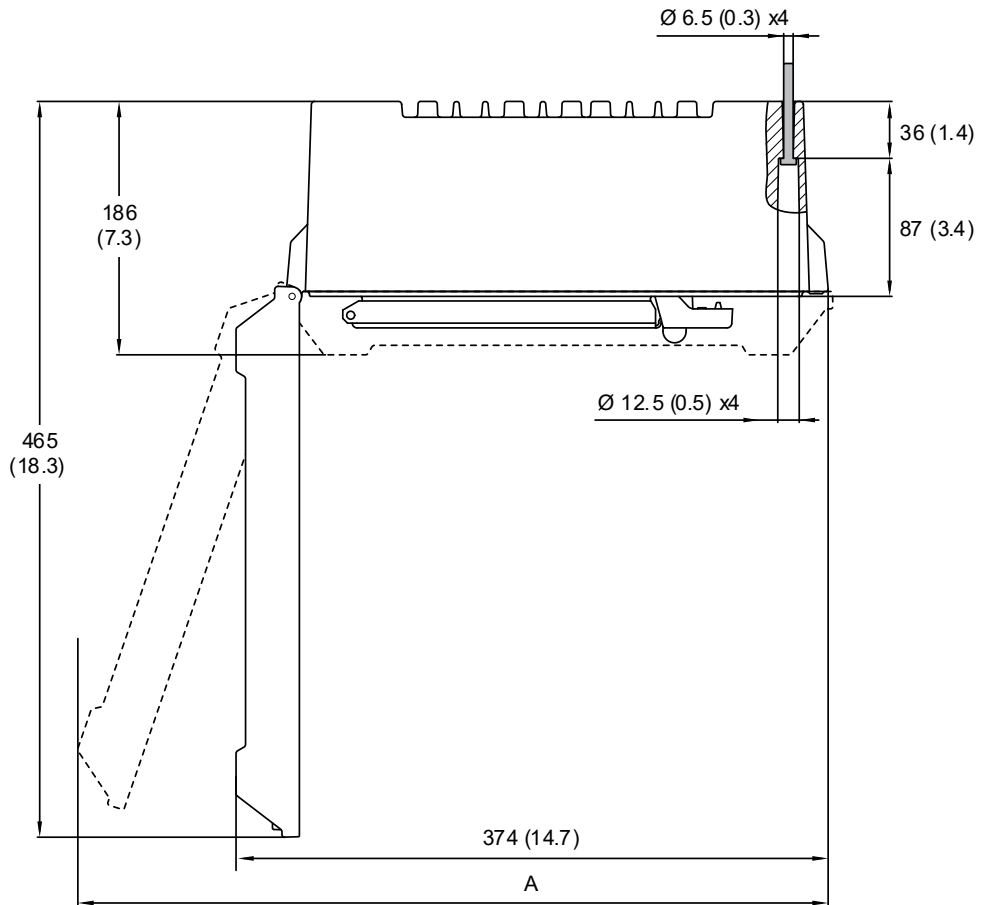

A. 474 (18.7) with lid maximum open

Dimensions are in millimeters (inches).



## A.7 Ordering information

### A.7.1 Model codes

Model codes contain the details related to each product. Exact model codes will vary; an example of a typical model code is shown in [Figure A-5](#).

---

**Figure A-5: Model Code Example**

2460 1 S 0 S R R R R FR FR TR TR 00 00 P R A 1 0	WR3
1	2

---

1. Required model components (choices available on most)
2. Additional options (variety of features and functions that may be added to products)

## A.7.2 Rosemount 2460 System Hub

### Required model components Model

Code	Description
2460	System Hub

### Capacity

Maximum number of tanks depends on selected field ports configuration. Depending on device type and application, the number of devices per tank, or number of tanks per device, may differ.

Code	Description
1	1-16 tanks
4	1-48 tanks
6	1-64 tanks

### Firmware

Code	Description
S	Standard
1	Inventory calculation, 1-16 tanks
4	Inventory calculation, 1-48 tanks
6	Inventory calculation, 1-64 tanks

### Redundancy/Remote access

Code	Description
0	None
R <sup>(1)(2)</sup>	Redundancy

- (1) Dual Rosemount 2460 System Hub redundancy requires two system hubs with identical model codes. For redundant systems with emulation, consult factory for technical guidance.
- (2) This option is required to be able to use field port redundancy and/or field device redundancy. Field port redundancy is only possible for TRL/2 and RS485 ports, where the same interface must be used on each pair. The capacity of the Rosemount 2460 is reduced when using field port redundancy.

### Modbus mapping

Code	Description
S	Standard
G <sup>(1)</sup>	User-defined Modbus mapping (Enables customized mapping for host communication.)

- (1) When using Modbus TCP in combination with user-defined Modbus mapping, the same Modbus mapping will be used for all clients. In this case, TankMaster cannot be used.

### Port 1 Field communication (serial port)

See [Table A-1](#) for maximum number of devices connected to each field port.

Code	Description
R	TRL2 Modbus
E	Enraf Bi-phase Mark GPU
G	GPE (Digital Current Loop)
P	GPE (RS485)
H	Whessoe WM 550/660 (Digital Current Loop)
Y	Whessoe WM 660 (RS485)
L <sup>(1)(2)</sup>	L&J Tankway
V <sup>(1)(2)</sup>	Varec Mark/Space
U <sup>(3)</sup>	Sakura V1, MDP, BBB
T	Tokyo Keiso, TIC
4	RS485 Modbus

(1) Not supported for redundant system hubs (Redundancy option code R).

(2) External power supply is required for powering the bus.

(3) Only one protocol can be used per port.

### Port 2 Field communication (serial port)

See [Table A-1](#) for maximum number of devices connected to each field port.

Code	Description
0 <sup>(1)</sup>	None
R	TRL2 Modbus
E	Enraf Bi-phase Mark GPU
G	GPE (Digital Current Loop)
P	GPE (RS485)
H	Whessoe WM 550/660 (Digital Current Loop)
Y	Whessoe WM 660 (RS485)
L <sup>(2)(3)</sup>	L&J Tankway
V <sup>(2)(3)</sup>	Varec Mark/Space
U <sup>(4)</sup>	Sakura V1, MDP, BBB
T	Tokyo Keiso, TIC
4	RS485 Modbus

(1) Empty ports will not be enabled for use. To activate an empty port after delivery, a port upgrade must be ordered.

(2) Not supported for redundant system hubs (Redundancy option code R).

(3) External power supply is required for powering the bus.

(4) Only one protocol can be used per port.

### Port 3 Field communication (serial port)

See [Table A-1](#) for maximum number of devices connected to each field port.

Code	Description
0 <sup>(1)</sup>	None
R	TRL2 Modbus
E	Enraf Bi-phase Mark GPU
G	GPE (Digital Current Loop)
P	GPE (RS485)
H	Whessoe WM 550/660 (Digital Current Loop)
Y	Whessoe WM 660 (RS485)
L <sup>(2)(3)</sup>	L&J Tankway
V <sup>(2)(3)</sup>	Varec Mark/Space
UJ <sup>(4)</sup>	Sakura V1, MDP, BBB
T	Tokyo Keiso, TIC
4	RS485 Modbus

- (1) Empty ports will not be enabled for use. To activate an empty port after delivery, a port upgrade must be ordered.
- (2) Not supported for redundant system hubs (Redundancy option code R).
- (3) External power supply is required for powering the bus.
- (4) Only one protocol can be used per port.

### Port 4 Field communication (serial port)

See [Table A-1](#) for maximum number of devices connected to each field port.

Code	Description
0 <sup>(1)</sup>	None
R	TRL2 Modbus
E	Enraf Bi-phase Mark GPU
G	GPE (Digital Current Loop)
P	GPE (RS485)
H	Whessoe WM 550/660 (Digital Current Loop)
Y	Whessoe WM 660 (RS485)
L <sup>(2)(3)</sup>	L&J Tankway
V <sup>(2)(3)</sup>	Varec Mark/Space
UJ <sup>(4)</sup>	Sakura V1, MDP, BBB
T	Tokyo Keiso, TIC
4	RS485 Modbus

- (1) Empty ports will not be enabled for use. To activate an empty port after delivery, a port upgrade must be ordered.
- (2) Not supported for redundant system hubs (Redundancy option code R).
- (3) External power supply is required for powering the bus.

(4) Only one protocol can be used per port.

### Port 5 Field or host communication (serial port)

See [Table A-1](#) for maximum number of devices connected to each field port.

Code	Description
00 <sup>(1)</sup>	None
FR	TRL2 Modbus, field communication
FE	Enraf Bi-phase Mark GPU, field communication
FG	GPE (Digital Current Loop), field communication
FP	GPE (RS485), field communication
FH	Whessoe WM 550/660 (Digital Current Loop), field communication
FY	Whessoe WM 660 (RS485), field communication
FL <sup>(2)(3)</sup>	L&J Tankway, field communication
FV <sup>(2) (3)</sup>	Varec Mark/Space, field communication
FU <sup>(4)</sup>	Sakura V1, MDP, BBB
FT	Tokyo Keiso, TIC
F4	RS485 Modbus (Fieldbus)
H8 <sup>(5)</sup>	Enraf CIU 858 emulation (RS485)
HR	TRL2 Modbus, host communication
H4	RS485 Modbus, host communication

(1) Empty ports will not be enabled for use. To activate an empty port after delivery, a port upgrade must be ordered.

(2) Not supported for redundant system hubs (Redundancy option code R).

(3) External power supply is required for powering the bus.

(4) Only one protocol can be used per port.

(5) Emulation of Enraf CIU 858 and configuration via Enraf FlexConn for connection to existing host system or service/configuration tool.

### Port 6 Field communication (serial port)

See [Table A-1](#) for maximum number of devices connected to each field port.

Code	Description
00 <sup>(1)</sup>	None
FR	TRL2 Modbus, field communication
FE	Enraf Bi-phase Mark GPU, field communication
FG	GPE (Digital Current Loop), field communication
FP	GPE (RS485), field communication
FH	Whessoe WM 550/660 (Digital Current Loop), field communication
FY	Whessoe WM 660 (RS485), field communication
FL <sup>(2)(3)</sup>	L&J Tankway, field communication
FV <sup>(2)(3)</sup>	Varec Mark/Space, field communication

Code	Description
FU <sup>(4)</sup>	Sakura V1, MDP, BBB
FT	Tokyo Keiso, TIC
F4	RS485 Modbus (Fieldbus)
H8 <sup>(5)</sup>	Enraf CIU 858 emulation (RS485)
HR	TRL2 Modbus, host communication
H4	RS485 Modbus, host communication

- (1) Empty ports will not be enabled for use. To activate an empty port after delivery, a port upgrade must be ordered.
- (2) Not supported for redundant system hubs (Redundancy option code R).
- (3) External power supply is required for powering the bus.
- (4) Only one protocol can be used per port.
- (5) Emulation of Enraf CIU 858 and configuration via Enraf FlexConn for connection to existing host system or service/configuration tool.

### Port 7 Host communication (serial port)

Code	Description
00 <sup>(1)</sup>	None
TR	TRL2 Modbus communication to TankMaster
T2	RS232 Modbus communication to TankMaster
T4	RS485 Modbus communication to TankMaster
HE <sup>(2)</sup>	Enraf CIU 858 emulation (RS232)
H8 <sup>(2)</sup>	Enraf CIU 858 emulation (RS485)
HR	TRL2 Modbus communication to host/DCS
H2	RS232 Modbus communication to host/DCS
H4	RS485 Modbus communication to host/DCS

- (1) Empty ports will not be enabled for use. To activate an empty port after delivery, a port upgrade must be ordered.
- (2) Emulation of Enraf CIU 858 and configuration via Enraf FlexConn for connection to existing host system or service/configuration tool.

### Port 8 Host communication (serial port)

Code	Description
TR	TRL2 Modbus communication to TankMaster
T2	RS232 Modbus communication to TankMaster
T4	RS485 Modbus communication to TankMaster

### OPC host communication (Ethernet)

Code	Description
00	None

### Modbus TCP host communication

Code	Description
00	None
MT	TankMaster TCP connection. Two TankMaster clients can connect.
MV	TankMaster TCP connection + 1 Modbus TCP client
M1 <sup>(1)(2)</sup>	1 Modbus TCP client
M5 <sup>(1)(2)</sup>	1-5 Modbus TCP clients

- (1) A redundant TankMaster system requires two clients when TankMaster is connected via Modbus TCP .  
 (2) When using Modbus TCP in combination with user-defined Modbus mapping, the same Modbus mapping will be used for all clients. In this case, TankMaster cannot be used.

### Power supply

Code	Description
P	100-250 Vac 50/60 Hz, 24-48 Vdc

### Custody transfer type approval

Requires Rosemount 5900S Radar Level Gauge and Rosemount 2410 Tank Hub with corresponding Custody transfer type approval.

Code	Description
R	OIML R85 edition 2008
A	CMI (Czech Republic)
C	PTB Eich (Germany)
I	Ministero (Italy)
L	LNE (France)
N	NMi (The Netherlands)
O	ONML (Algeria)
T	ANM (Tunisia)
0	None

### Housing

Code	Description
A	Aluminum (polyurethane-covered), IP 65

### Cable/conduit connections

Code	Description
G	Metal cable glands (M20 x1.5 and M25 x1.5) <ul style="list-style-type: none"> <li>• 2 pcs M25 plugs</li> <li>• 7 pcs M20 plugs</li> <li>• 2 pcs M25 glands</li> <li>• 9 pcs M20 glands</li> </ul>

Code	Description	
1	NPT adapters (½ -14 NPT and ¾ -14 NPT)	Includes: <ul style="list-style-type: none"> <li>• 2 pcs M25 plugs</li> <li>• 7 pcs M20 plugs</li> <li>• 2 pcs ¾-14 NPT adapters</li> <li>• 9 pcs ½-14 NPT adapters</li> </ul>
2	Metal plugs (M20 x 1.5 and M25 x1.5)	Includes: <ul style="list-style-type: none"> <li>• 2 pcs M25 plugs</li> <li>• 7 pcs M20 plugs</li> </ul>

### Extra

Code	Description
0	None

### Additional options Tag plate

Code	Description
ST	Engraved SST tag plate

### Conformance certificate

Code	Description
Q1	Printed copy of certificate of conformance

### Extended warranty

Standard warranty is 18 months from delivery.

Code	Description
WR3	3-year limited warranty
WR5	5-year limited warranty



# B Enraf® device configuration

## B.1 Tank Database configuration for Enraf® devices

This section describes how to configure the Tank Database of the Rosemount 2460 System Hub for supported Enraf® devices.

### Procedure

1. In TankMaster WinSetup right-click the Rosemount 2460 System Hub that the device is connected to and choose **Properties**.
2. Select the **Tank Database** tab.

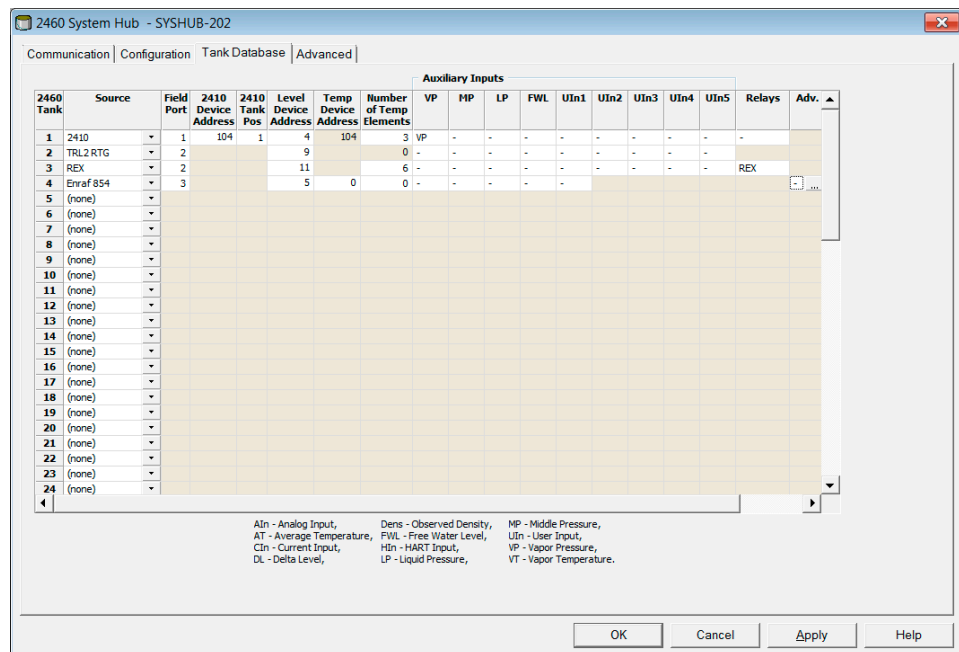

3. Find a free tank position (2460 Tank 1, 2, 3...) for the device to be configured.

- In the **Source** field, choose the appropriate Enraf device type (Enraf 811, 813, etc.).

The screenshot shows the '2460 System Hub - SYSHUB-202' interface. The 'Tank Database' tab is active, displaying a table with columns: 2460 Tank, Source, Field Port, 2410 Device Address, 2410 Tank Pos, Level Device Address, Temp Device Address, Number of Temp Elements, VP, MP, LP, FWL, UIn1, UIn2, UIn3, UIn4, UIn5, Relays, and Adv. A dropdown menu is open for the 'Source' field of row 4, listing options: (none), 2410, REX, REX + DAU, PRO, PRO + DAU, TRL2 RTG, TRL2 RTG + DAU, Enraf 811, Enraf 813, Enraf 854, Enraf 873, Enraf 894, Enraf 970, Enraf 971, Enraf TOI B, and (none).

2460 Tank	Source	Field Port	2410 Device Address	2410 Tank Pos	Level Device Address	Temp Device Address	Number of Temp Elements	VP	MP	LP	FWL	UIn1	UIn2	UIn3	UIn4	UIn5	Relays	Adv.
1	2410	1	104	1	4	104	3	VP	-	-	-	-	-	-	-	-	-	-
2	TRL2 RTG	2			9		0	-	-	-	-	-	-	-	-	-	-	-
3	REX	2			11		6	-	-	-	-	-	-	-	-	-	REX	-
4	Enraf 854	3			5		0	-	-	-	-	-	-	-	-	-	-	-
5	(none)																	
6	2410																	
7	REX																	
8	REX + DAU																	
9	PRO																	
10	PRO + DAU																	
11	TRL2 RTG																	
12	TRL2 RTG + DAU																	
13	Enraf 811																	
14	Enraf 813																	
15	Enraf 854																	
16	Enraf 873																	
17	Enraf 894																	
18	Enraf 970																	
19	Enraf 971																	
20	Enraf TOI B																	
21	(none)																	
22	(none)																	

In case you cannot find a suitable Enraf device you should choose **Enraf TOI B**.

- Select the **Field Port** that the device is connected to.  
Ensure that the port is equipped with an Enraf modem. In the standard configuration there are six field bus ports available for the Rosemount 2460 System Hub.
- Enter the address of the Enraf servo gauge into the **Level Device Address** field.  
Each field device has its own unique address in the range 00-99.
- In the **Temp Device Address** field, enter the level device address in case the temperature elements are connected to the servo gauge. If the temperature elements are connected to an external temperature transmitter, enter the address of this device. Entering a temperature device address will ensure that the 2460 includes **Average Temperature** when sending requests for measurement data.
- In the **Number of Temp Elements** field, enter "0" elements in case only **Average Temperature** is required.  
If you would like to retrieve individual temperature values for each spot element, you have to enter the total number of connected elements. In case you don't need to monitor values for individual temperature elements you should set this parameter to "0" in order to avoid unnecessary load on the field bus.
- Select the **Auxiliary Inputs** that are used for the device.  
Vapor Pressure (VP), Middle Pressure (MP), Liquid Pressure (LP), Free Water Level (FWL), and Observed Density (UIn1) can be configured for Enraf devices.

### Related information

- [Enraf modem card](#)
- [Connecting to a Rosemount 2460 System Hub](#)
- [Tank Database entry fields for Enraf devices](#)

## B.1.1 Tank Database entry fields for Enraf devices

**Table B-1: Summary of Tank Database Entry Fields**

Entry field	Description
Source	Enraf <sup>(1)</sup> (811, 813, 854, 873, 894, 970, 971, TOI-B)
Field Port	The field bus port that the selected device is connected to. Up to six field ports may be used.
Level Device Address	Enraf level device address. Each field device has its own unique address in the range 00-99.
Temp Device Address	Use the same address as the Enraf level device.
Number of Temp Elements	“0” in case only average temperature is required. Otherwise the total number of connected temperature elements. In case you don’t need to monitor values for individual temperature elements you should set this parameter to “0” in order to avoid unnecessary load on the field bus.
Auxiliary Inputs	<ul style="list-style-type: none"> <li>• Free Water Level</li> <li>• Liquid Pressure</li> <li>• Middle Pressure</li> <li>• Vapor Pressure</li> <li>• Observed Density (UIn1)</li> </ul>
Advanced	<ul style="list-style-type: none"> <li>• Vapor temperature</li> <li>• Fast polling</li> </ul>

(1) Enraf option is supported for 2460 firmware version 1.B0 and higher.

### Related information

[Advanced Enraf configuration](#)

## B.2 Advanced Enraf configuration

This section describes how to enable and configure Fast Polling for Enraf devices. Fast polling can be used to increase the sampling rate for tanks with level rates above a certain threshold value.

A general threshold setting can be configured which applies for all servo tanks. It is also possible to configure threshold values for individual servo tanks.

### B.2.1 Fast polling

See [Fast polling](#) for information on how to setup fast polling.

### B.2.2 Configure Vapor Temperature

#### Procedure

1. Open TankMaster WinSetup.
2. In the WinSetup workspace, click the right mouse button on the Rosemount 2460 icon and choose **Properties**.

3. Select the **Tank Database** tab.
4. Click the **Advanced** button for the desired tank to open the **Enraf Configuration** window.

2460 Tank	Source	Field Port	2410 Device Address	2410 Tank Pos	Level Device Address	Temp Device Address	Number of Temp Elements	Auxiliary Inputs					Relays	Adv. ▲			
								VP	MP	LP	FWL	UIn1			UIn2	UIn3	UIn4
1	2410	1	104	1	4	104	3	VP	-	-	-	-	-	-	-	-	-
2	TRL2 RTG	2			9		0	-	-	-	-	-	-	-	-	-	-
3	REX	2			11		6	-	-	-	-	-	-	-	-	-	REX
4	Enraf 854	3			5		0	-	-	-	-	-	-	-	-	-	...
5	(none)																
6	(none)																
7	(none)																
8	(none)																
9	(none)																

5. The **Enraf Configuration** window lets you configure **Vapor Temperature** for the selected tank.

Enraf 854 Configuration

Temperature Configuration

Vapor Temperature

Advanced Fast Polling Configuration

Hysteresis:  m/h

Threshold:  m/h

OK Cancel Help

6. Click **OK** to save the current configuration and close the window.

## C Servo commands

### C.1 Send a servo command

For tanks configured as servo tanks, it is possible to send commands to a servo gauge, such as an Enraf® series 854, using the **Servo Command** window.

#### Prerequisites

To send a servo command, a tank must first be configured as a servo tank. See the Rosemount Tank Gauging [System Configuration Manual](#) (Document No. 00809-0300-5100) for more information on tank installation and configuration.

#### Procedure

1. Right-click on a servo tank in the Workspace window and select **Send Servo Command** in the menu to open the **Servo Command** window, or select **Entry** → **Send Servo Command** in the main toolbar.

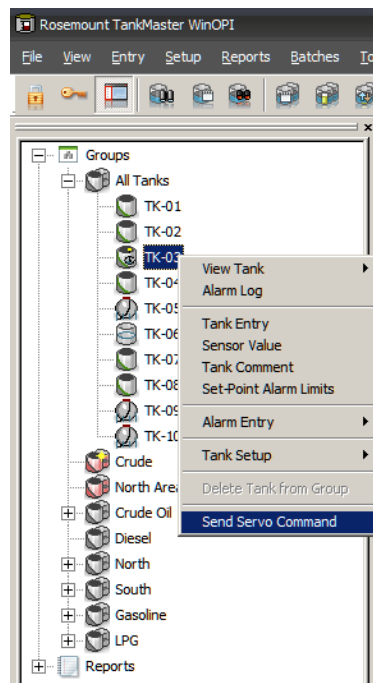

- Click a servo command to be sent to the servo tank.

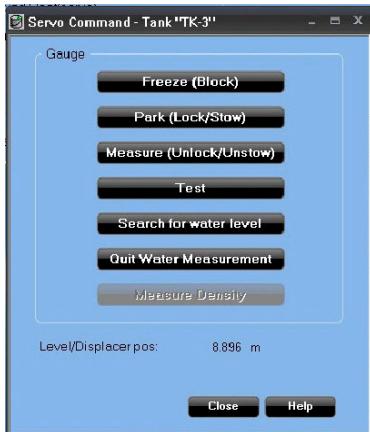

When a servo command is sent, the **Level /Displacer position** field in the **Servo Command** window turns orange and the servo state is displayed to the left of the **Level /Displacer position** value as an abbreviation.

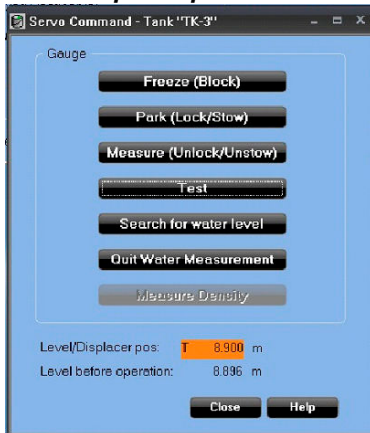

Servo Command	Abbreviation
Freeze (Block)	F
Park (Lock/Stow)	P
Test	T
Search for water level	D
Water level found	W
Density scan active	R

- Before you close the **Servo Command** window, verify that the servo command indicator next to **Level /Displacer pos.** field is cleared, e.g. the **T** for Test is not visible.
- Click **Close**.

### C.1.1 Servo commands

The following commands are available:

**Table C-1: Servo Commands**

Command	Description
Freeze (Block)	Holds the displacer in its current position.
Park (Lock/Stow)	Raises the displacer to the top of the tank.
Measure (Unlock/Unstow)	Unlocks the gauge after Freeze or Park, and the displacer moves to the surface of the product.
Test	Raises the displacer and then returns it to the surface of the product.
Search for water level	Initiates a search for the product/water interface.
Quit Water Measurement	Quit measuring the water interface and return to measure the product level.
Measure Density	Displacer will be lowered into the product to measure the product density.

## C.1.2 Tank inventory

When a Servo Command is executed the Level position field in all **View Tank** windows turns orange. All Inventory (volume) calculations are disabled as long as the servo command is active - only **Level** and **Temperature** values are displayed.

Figure C-1: Tank Inventory

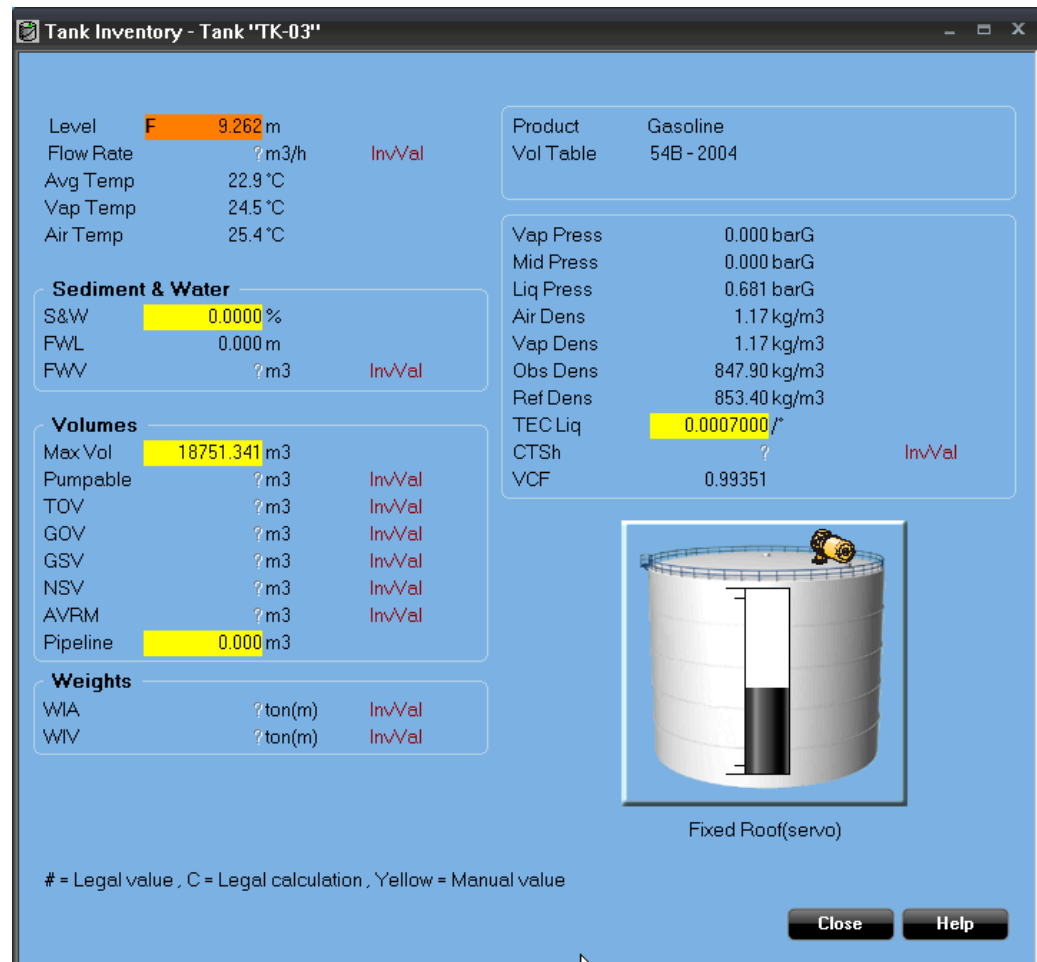

**Note**

When a servo command is active, the **Level** value does not show the current product level. The level shown is the current displacer position.



## C.2 Servo states

Table C-2 shows the different servo commands and servo states shown when using a Rosemount 2460 System Hub.

**Table C-2: Servo Command and Servo State Displayed by the 2460**

Servo Command	Displayed servo state in Windows		
	Rosemount 2460 System Hub		
	Up	Freeze	Down
Park (Lock/Stow)	P	F	-
Freeze (Block)	-	F	-
Measure (Unlock/Unstow)	-	-	T
Test	T	-	T
Search for water level	-	-	D
Water found	-	W	-
Quit water	T	-	-

The Raise, Freeze and Lower servo states refer to the displacer movement.

### Note

When a servo command is active and the displacer is moving, the active device communication is prioritized.

### C.2.1 OPC and Modbus

The current servo command is viewable via OPC or Modbus from a host computer.

To view the servo command status via OPC, use the **TK.xx.LL.SS** tag.

## C.3 Type of request (TOR)

The Rosemount 2460 System Hub supports the following Type of Requests (TOR):

**Table C-3: TOR Support by 2460 Enraf Client Server**

TOR	Description
B	Data Request: Alarm Status, Level Status and Level Value
C	Data Request: Alarm Status, Temp Status and signed Temp Value
D	Data Request: Alarm Status, Level Status, Level Value, Temp Status and signed Temp Value
M	Data Request: Alarm Status, Water Level Status and signed Water Level Value (1/10mm)
X	Identification Request: Identification
Z	Item message. Two extra characters are sent after TOR = Z. See <a href="#">Table C-4</a> .

The data field of a Z-record always includes an ITEM, including two characters. The ITEM of type request is the only type to send by the Enraf client.

**Table C-4: Z Item Message**

Z item	Description
V0 - VF	Spot Temperature 0-15, i.e. Temperature sensor 1-16
AG	Average Vapor Temperature
P1	Product Pressure
P2	Middle Pressure
P3	Vapor Pressure
DQ	Density

# D Whessoe device configuration

## D.1 Tank Database configuration for Whessoe devices

This section describes how to configure the Tank Database of the Rosemount 2460 System Hub for supported Whessoe devices.

### Procedure

1. In TankMaster WinSetup right-click the Rosemount 2460 System Hub that the device is connected to and choose **Properties**.
2. Select the **Tank Database** tab.

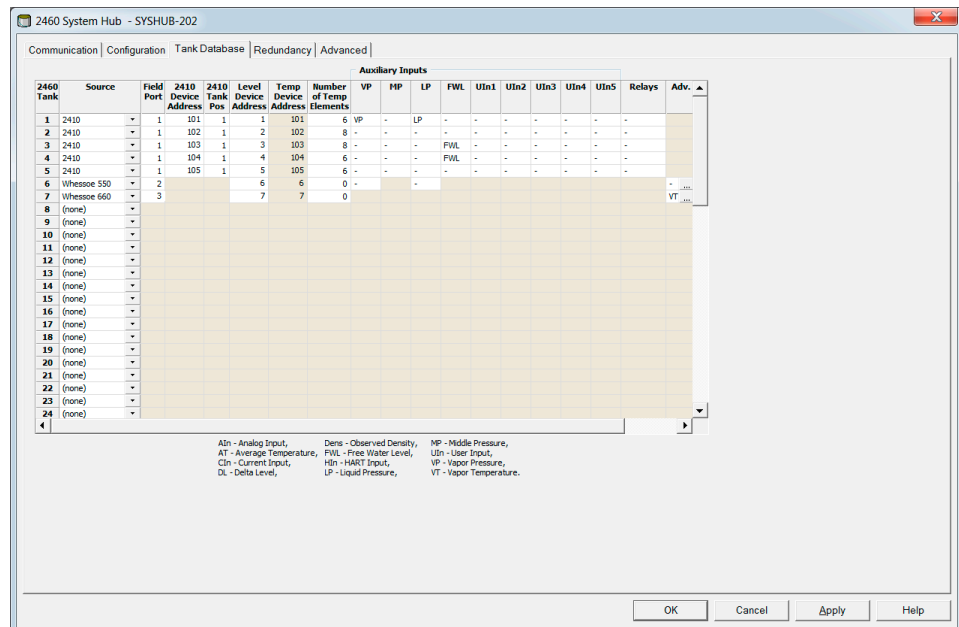

3. Find a free tank position (2460 Tank 1, 2, 3...) for the device to be configured.
4. In the **Source** field, choose the appropriate Whessoe device type (Whessoe WM550, WM660).

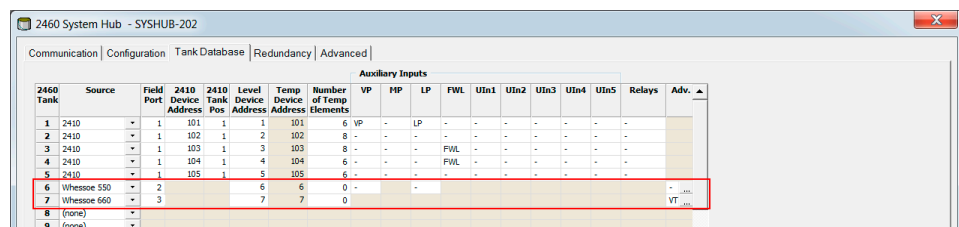

5. Select the **Field Port** that the device is connected to.  
Ensure that the port is equipped with a Digital Control Loop modem. In the standard configuration there are six field bus ports available for the Rosemount 2460 System Hub.

6. Enter the address of the gauge into the **Level Device Address** field.  
Each field device has its own unique address in the range 00-99.
7. The **Temp Device Address** field can not be edited. The address is automatically set to the address of the level device.
8. In the **Number of Temp Elements** field, enter "0" elements in case only **Average Temperature** is required.  
If you would like to retrieve individual temperature values for each spot element, you have to enter the total number of connected elements. In case you don't need to monitor values for individual temperature elements you should set this parameter to "0" in order to avoid unnecessary load on the field bus.
9. Select the **Auxiliary Inputs** that are used for the device.  
Vapor Pressure (VP), Liquid Pressure (LP), and Vapor Temperature can be configured for Whessoe devices.
10. See [Advanced Whessoe configuration](#) for advanced options for the Whessoe 550/660.

#### Related information

[Modem Multi Loop](#)

[Connecting to a Rosemount 2460 System Hub](#)

[Tank Database entry fields for Whessoe devices](#)

## D.1.1 Tank Database entry fields for Whessoe devices

**Table D-1: Summary of Tank Database Entry Fields**

Entry field	Description
Source	Whessoe <sup>(1)</sup> (WM550, WM660)
Field Port	The field bus port that the selected device is connected to. Up to six field ports may be used.
Level Device Address	Level device address. Each field device has its own unique address in the range 0-99.
Temp Device Address	Use the same address as the level device.
Number of Temp Elements	<p>"0" in case only average temperature is required. Otherwise the total number of connected temperature elements.</p> <p>In case you don't need to monitor values for individual temperature elements you should set this parameter to "0" in order to avoid unnecessary load on the field bus.</p>
Auxiliary Inputs	<p>Whessoe WM550</p> <ul style="list-style-type: none"> <li>Vapor Pressure<sup>(2)</sup></li> <li>Liquid Pressure<sup>(2)</sup></li> </ul> <p>Whessoe WM660</p> <ul style="list-style-type: none"> <li>None</li> </ul>
Advanced	<p>Whessoe WM550</p> <ul style="list-style-type: none"> <li>Fast polling</li> </ul> <p>Whessoe WM660</p> <ul style="list-style-type: none"> <li>Vapor temperature</li> </ul>

(1) Whessoe option is supported for 2460 firmware version 1.D0 and higher.

(2) Vapor or Liquid pressure

## D.2 Advanced Whessoe configuration

This section describes how to configure pressure range values for the Whessoe WM550, and how to enable Vapor Temperature for the Whessoe WM660.

### D.2.1 Fast polling

See [Fast polling](#) for information on how to setup fast polling.

### D.2.2 Configure range values for Whessoe WM550

To configure range values for vapor and liquid pressure:

#### Procedure

1. Open TankMaster WinSetup.
2. Click the right mouse button on the Rosemount 2460 icon and select **Properties**.

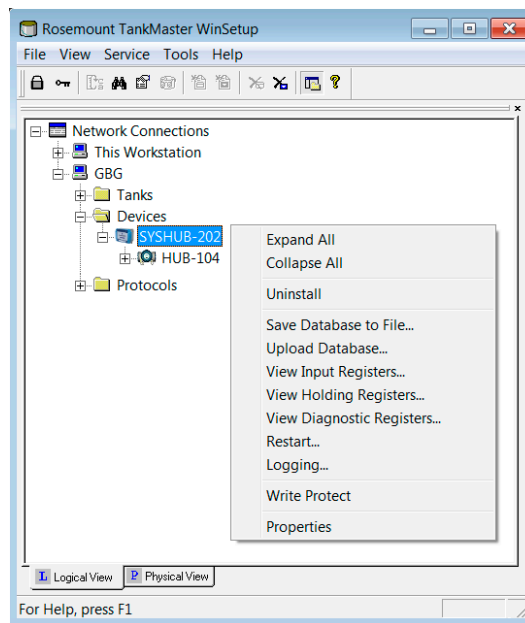

3. Select the **Advanced** tab and click the **Whessoe 550** button.

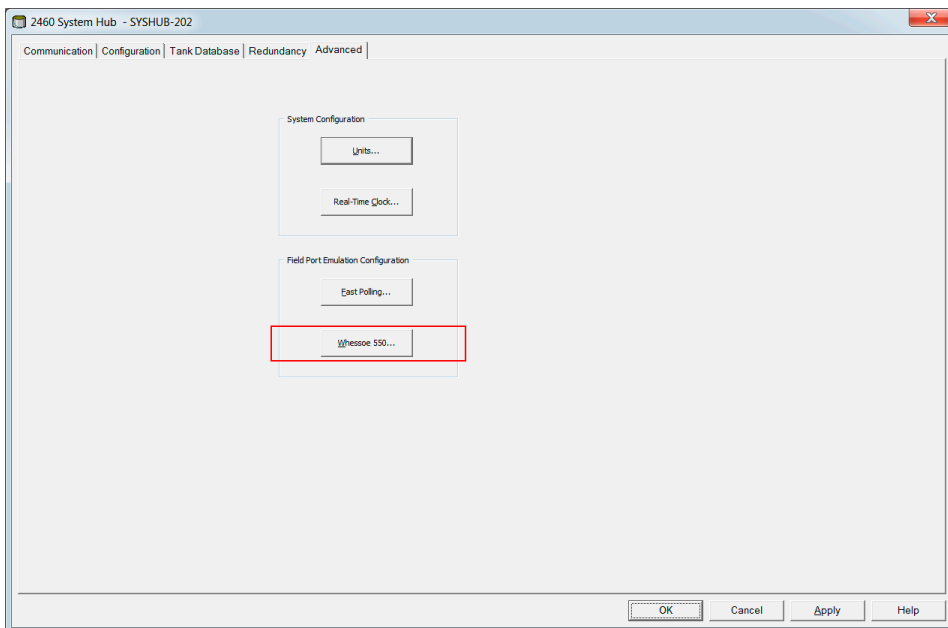

4. Enter the desired **Low Range** and **High Range** values for the appropriate pressure parameters.
5. Click **Apply** to save the current configuration.
6. Click **OK** to close the window.

### Advanced Whessoe 550 configuration window

The **Advanced Whessoe 550 Configuration** window lets you to set the Low Range and High Range values for Vapor and Product pressure. These values allow the Rosemount 2460 to perform scaling of collected pressure data to the correct values in bar.

Figure D-1: Advanced Whessoe 550 Configuration window

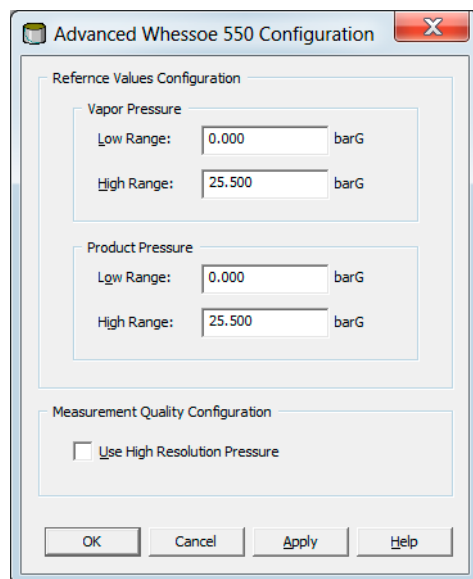

The **Use High Resolution Pressure** option allows the system hub to increase resolution from the standard 8 bit floating point value to a 13 bit resolution. However, this is not Whessoe standard and may not be supported by the Whessoe device.

## D.2.3 Configure Vapor Temperature for Whessoe WM660

### Procedure

1. Open TankMaster WinSetup.
2. In the WinSetup workspace, click the right mouse button on the Rosemount 2460 icon and choose **Properties**.
3. Select the **Tank Database** tab.
4. Click the **Advanced** button for the desired Whessoe 660 device to open the **Whessoe 660 Configuration** window.

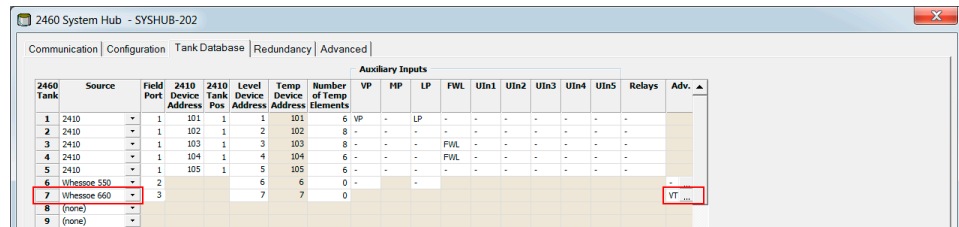

5. The **Whessoe 660 Configuration** window lets you configure **Vapor Temperature** for the selected tank.

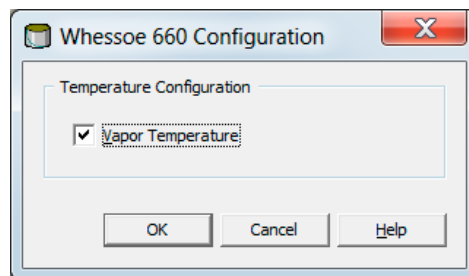

6. Click **OK** to save the current configuration and close the window.



# E Modbus® standard question

## E.1 Introduction

The Rosemount 2460 System Hub polls field devices and stores the information in input registers. This allows Rosemount TankMaster and other host systems to read measurement data and status information for a large number of tanks. This appendix lists the input registers which can be scanned in queries from a Modbus master.

### E.1.1 Priority

Polling will occur at certain intervals as specified in [Table E-1](#).

**Table E-1: Read interval**

Priority	Register Area	Read interval in master
1	<ul style="list-style-type: none"> <li>Level</li> </ul>	1 per second
2	<ul style="list-style-type: none"> <li>Average Temperature</li> <li>Pressure</li> </ul>	1 per 10 seconds
3	<ul style="list-style-type: none"> <li>Temperature Element</li> <li>Density</li> </ul>	1 per 30 seconds
4	<ul style="list-style-type: none"> <li>Free Water Level</li> <li>Ambient Air Temperature</li> <li>Ambient Air Pressure</li> <li>Relay State</li> </ul>	1 per 60 seconds
5	<ul style="list-style-type: none"> <li>Units</li> <li>Diagnostic</li> </ul>	1 per 120 seconds

## E.2 FC02 status register area

Read status information for the parameter value in the FC04 area.

Sensor data: a '0' means valid, a '1' means invalid.

Alarm data: a '0' means normal, a '1' means alarm.

**Table E-2: Tank Register Area**

Register Number	Register Name
0-63	Level Status
64-127	Level Rate Status
128-191	Ullage Status
192-255	Free Water Level Status
448-511	Average Product Temperature Status
512-575	Average Vapor Temperature Status
576-639	Temperature Element 1 Status
640-703	Temperature Element 2 Status
704-767	Temperature Element 3 Status
768-831	Temperature Element 4 Status
832-895	Temperature Element 5 Status
896-959	Temperature Element 6 Status
960-1023	Temperature Element 7 Status
1024-1087	Temperature Element 8 Status
1088-1151	Temperature Element 9 Status
1152-1215	Temperature Element 10 Status
1216-1279	Temperature Element 11 Status
1280-1343	Temperature Element 12 Status
1344-1407	Temperature Element 13 Status
1408-1471	Temperature Element 14 Status
1472-1535	Temperature Element 15 Status
1536-1599	Temperature Element 16 Status
1600-1663	Vapor Pressure (P3) Status
1664-1727	Middle Pressure (P2) Status
1728-1791	Product Pressure (P1) Status
1792-1855	User Defined 1 Value Status
1856-1919	User Defined 2 Value Status
1920-1983	User Defined 3 Value Status
1984-2047	User Defined 4 Value Status
2048-2111	User Defined 5 Value Status
2496-2559	Relay 1 Status

**Table E-2: Tank Register Area (continued)**

Register Number	Register Name
2560-2623	Relay 2 Status
2624-2687	Relay 3 Status
2688-2751	Relay 4 Status
2752-2815	Relay 5 Status
2816-2879	Relay 6 Status
2880-2943	Relay 7 Status
2944-3007	Relay 8 Status
3008-3071	Relay 9 Status
3072-3135	Relay 10 Status
3136-3199	Level Signal Strength
3200-3263	Observed Density
3264-3327	Reference Density
3328-3391	CTPL
3584-3647	FlowRate
3648-3711	Free Water Volume
3712-3775	Total Observed Volume
3776-3839	Available Volume Room
3840-3903	Pumpable Volume
3904-3967	Tankshell Temperature Correction
3968-4031	Floating Roof Adjustment
4032-4095	Gross Observed Volume
4096-4159	Gross Standard Volume
4160-4223	Net Standard Volume
4224-4287	Weight in Air
4288-4351	Weight in Vacuum
4352-4415	Vapor Liquid Volume
4416-4479	Vapor Mass
4480-4543	Product Mass
5056-5119	Safety Relay Status

## E.3 FC03 register area

Read Holding Register.

**Table E-3: System Register Area**

Register Number	Register Name	Type	Unit	Description
	<b>Unit Register Area</b>			Priority 5 question. Defines the unit for values in the FC04 area.
100	Level Unit	WORD	NA	SENUM: 44 = ft 45 = m (default)
101	Level Rate Unit	WORD	NA	SENUM: 120 = m/h (default) 247 = ft/h
102	Temperature Element Unit	WORD	NA	SENUM: 1 = 1/10 ° (default) 2 = 1/100 ° Resolution for the temperature value. The temperature unit below will be used.
103	Temperature Unit	WORD	NA	SENUM: 32 = °C (default) 33 = °F
104	Pressure Unit	WORD	NA	SENUM: 11 = Pa 12 = kPa 262 = psi A 263 = bar A 267 = Pa A 268 = kPa A 495 = mm H <sub>2</sub> O A 518 = psi G 519 = bar G (default) 523 = Pa G 524 = kPa G 751 = mm H <sub>2</sub> O G
105	Density Unit	WORD	NA	SENUM: 92: kg/m <sup>3</sup> 93: lb/gal(US) 104: degAPI 90: 60/60 Deg_F 96: kg/l

**Table E-3: System Register Area (continued)**

Register Number	Register Name	Type	Unit	Description
106	Volume Unit	WORD	NA	SENUM: 40: US Gallon 41: Liter 43: m3 46: Barrels
107	Weight Unit	WORD	NA	SENUM: 62: ton (m) 64: ton (s) 65: ton (l) 61: kg 63: lb
108	Flow Rate Unit	WORD	NA	SENUM: 17: Liter/minuts 19: m3/h 134: bbl/h 136: US Gallon/h

## E.4 FC04 register area

Read Input Register.

### E.4.1 Tank register area

Table E-4: Tank Register Area

Register Number	Register Name	Type	Unit	Description
	<b>Level Register Area</b>			Priority 1 question
0-127	Level	FLOAT	m, ft	
128-255	Level Rate	FLOAT	m/h, ft/h	
256-383	Ullage	FLOAT	m, ft	
384-511	Free Water Level	FLOAT	m, ft	Priority 4 question
	<b>Temperature Register Area</b>			
896-1023	Average Product Temperature	FLOAT	°C, °F	Priority 2 question
1024-1151	Average Vapor Temperature	FLOAT	°C, °F	
1152-1215	Temperature Element Value 1	SWORD	1/10°, 1/100°	Priority 3 question
1216-1279	Temperature Element Value 2	SWORD	1/10°, 1/100°	Default unit: 1/10° 1/10 °C or 1/10 °F with 1 decimal and range between -3200.0° and +3200.0° Alternative unit: 1/100° 1/100°C or 1/100 °F with 2 decimals and with range between -320.00° and +320.00°
1280-1343	Temperature Element Value 3	SWORD	1/10°, 1/100°	
1344-1407	Temperature Element Value 4	SWORD	1/10°, 1/100°	
1408-1471	Temperature Element Value 5	SWORD	1/10°, 1/100°	
1472-1535	Temperature Element Value 6	SWORD	1/10°, 1/100°	
1536-1599	Temperature Element Value 7	SWORD	1/10°, 1/100°	
1600-1663	Temperature Element Value 8	SWORD	1/10°, 1/100°	
1664-1727	Temperature Element Value 9	SWORD	1/10°, 1/100°	
1728-1791	Temperature Element Value 10	SWORD	1/10°, 1/100°	
1792-1855	Temperature Element Value 11	SWORD	1/10°, 1/100°	
1856-1919	Temperature Element Value 12	SWORD	1/10°, 1/100°	
1920-1983	Temperature Element Value 13	SWORD	1/10°, 1/100°	
1984-2047	Temperature Element Value 14	SWORD	1/10°, 1/100°	
2048-2111	Temperature Element Value 15	SWORD	1/10°, 1/100°	
2112-2175	Temperature Element Value 16	SWORD	1/10°, 1/100°	
	<b>Pressure Register Area</b>			
2176-2303	Vapor Pressure (P3)	FLOAT	barG, psiG	
2304-2431	Middle Pressure (P2)	FLOAT	barG, psiG, ..	
2432-2559	Product Pressure (P1)	FLOAT	barG, psiG, ..	

**Table E-4: Tank Register Area (continued)**

Register Number	Register Name	Type	Unit	Description
	<b>User Defined Register Area</b>			Priority 3 question
2560-2687	User Defined 1 Value	FLOAT		Unit is specified in Unit Register Area below, see register 9344-9663. Status is specified in Status Register Area, see register 4224-4351.
2688-2815	User Defined 2 Value	FLOAT		
2816-2943	User Defined 3 Value	FLOAT		
2944-3071	User Defined 4 Value	FLOAT		
3072 -3199	User Defined 5 Value	FLOAT		
3840-3965	Extended Standard Status	FLOAT		Bitfield: 0: Reduced accuracy warning Level 16: Reduced accuracy warning Product Temp Extended value status with warning bits for reduced accuracy, used for Enraf level and temp values.

**Table E-4: Tank Register Area (continued)**

Register Number	Register Name	Type	Unit	Description
	<b>Status Register Area</b>			
3968-4095	Standard Status	DWORD	Bitfield	Priority 1 question Bit 0: Simulated Level Bit 1: Manual Level Bit 2: Invalid Level Bit 3: CFail Level Bit 4: MI Approved Level Bit 5: MI Legal Level Bit 6: Backup Level used Bit 7: Spare Bit 8: Simulated FWL Bit 9: Manual FWL Bit 10: Invalid FWL Bit 11: CFail FWL Bit 12: Reserved Bit 13: Reserved Bit 14: Backup FWL used Bit 15: Spare Bit 16: Simulated Product Temp Bit 17: Manual Product Temp Bit 18: Invalid Product Temp Bit 19: CFail Product Temp Bit 20: MI Approved Product Temp Bit 21: MI Legal Product Temp Bit 22: Backup Product Temp used Bit 23: Spare Bit 24: Simulated Vapor Temp Bit 25: Manual Vapor Temp Bit 26: Invalid Vapor Temp Bit 27: CFail Vapor Temp Bit 28: MI Approved Vapor Temp Bit 29: MI Legal Vapor Temp Bit 30: Backup Vapor Temp used Bit 31: Spare



**Table E-4: Tank Register Area (continued)**

Register Number	Register Name	Type	Unit	Description
4096-4223	Pressure Status	DWORD	Bitfield	Priority 2 question Bit 0: Simulated Vapor Pressure Bit 1: Manual Vapor Pressure Bit 2: Invalid Vapor Pressure Bit 3: CFail Vapor Pressure Bit 4: Reserved Bit 5: Reserved Bit 6: Backup Vapor Pressure used Bit 7: Spare Bit 8: Simulated Middle Pressure Bit 9: Manual Middle Pressure Bit 10: Invalid Middle Pressure Bit 11: CFail Middle Pressure Bit 12: Reserved Bit 13: Reserved Bit 14: Backup Middle Pressure used Bit 15: Spare Bit 16: Simulated Product Pressure Bit 17: Manual Product Pressure Bit 18: Invalid Product Pressure Bit 19: CFail Product Pressure Bit 20: Reserved Bit 21: Reserved Bit 22: Backup Product Pressure used Bit 23: Spare

**Table E-4: Tank Register Area (continued)**

Register Number	Register Name	Type	Unit	Description
4224-4351	User Defined Value Status	DWORD	Bitfield	Priority 3 question Bit 0: Simulated User Def 1 Bit 1: Manual User Def 1 Bit 2: Invalid User Def 1 Bit 3: CFail User Def 1 Bit 4: Backup User Def 1 used Bit 5: Spare Bit 6: Simulated User Def 2 Bit 7: Manual User Def 2 Bit 8: Invalid User Def 2 Bit 9: CFail User Def 2 Bit 10: Backup User Def 2 used Bit 11: Spare Bit 12: Simulated User Def 3 Bit 13: Manual User Def 3 Bit 14: Invalid User Def 3 Bit 15: CFail User Def 3 Bit 16: Backup User Def 3 used Bit 17: Spare Bit 18: Simulated User Def 4 Bit 19: Manual User Def 4 Bit 20: Invalid User Def 4 Bit 21: CFail User Def 4 Bit 22: Backup User Def 4 used Bit 23: Spare Bit 24: Simulated User Def 5 Bit 25: Manual User Def 5 Bit 26: Invalid User Def 5 Bit 27: CFail User Def 5 Bit 28: Backup User Def 5 used Bit 29: Spare
4352-4479	Temperature Element Status	DWORD	Bitfield	Priority 3 question Bit 0: Invalid value E1 .. Bit 15: Invalid value E16 Bit 16: Cfail E1 .. Bit 31: Cfail E16
4608-4671	Temperature Element in Product Status	WORD	Bitfield	Bit 0: Element1 in product .. Bit 15: Element16 in product
4672-4735	Temperature Element in Vapor Status	WORD	Bitfield	Bit 0: E1 in vapor .. Bit 15: E16 in vapor

Table E-4: Tank Register Area (continued)

Register Number	Register Name	Type	Unit	Description
4736-4799	Temperature Element Blocked Status	WORD	Bitfield	Blocked from Avg. calculation Bit 0: E1 is blocked. .. Bit 15: E16 is blocked
4864-4991	Relay Status	DWORD	Bitfield	Priority 4 question Bit 0 - 9 (Relay1 - Relay10) (0 = Not energized, 1 = Energized) Bit 10 - 19 (Relay1 - Relay10) (0 = OK or Disabled, 1 = Error) Bit 20 - 29 (Relay1 - Relay10) (0 = Used, 1 = Disabled) Bit 30 Invalid Status (2460 set to 1 if old status or cfail) Bit 31 Cfail (2460 set to 1 if sub device does not answer, bit 10-19 will also be set to 1)
4992-5119	Safety Relay Status	DWORD	Bitfield	Priority 4 question Bit 0 (Relay1) (0 = Not energized, 1 = Energized) Bit 10 (Relay1) (0 = OK or Disabled, 1 = Error) Bit 20 (Relay1) (0 = Used, 1 = Disabled) Bit 30 Invalid Status (2460 set to 1 if old status or cfail) Bit 31 Cfail (2460 set to 1 if sub device does not answer, bit 10 will also be set to 1)
5248-5375	Observed Density	FLOAT		
5376-5503	Reference Density	FLOAT		
5504-6015	CTPL	FLOAT		Correction for temperature and pressure of the liquid used to convert Observed Density to Reference Density and observed volume to standard volume.
6016-6143	Flow Rate	LINT		Flow Rate, register value = m <sup>3</sup> /h * 1000, bbl/h * 100, gal/h * 100
6144-6271	Free Water Volume	DWORD		Free water volume, register value = m <sup>3</sup> * 1000, bbl * 100, gal * 100
6272-6399	Total Observed Volume	DWORD		Total observed volume, register value = m <sup>3</sup> * 1000, bbl * 100, gal * 100
6400-6527	Available Volume Room	DWORD		Available Volume Room, register value = m <sup>3</sup> * 1000, bbl * 100, gal * 100
6528-6655	Pumpable Volume	DWORD		Pumpable Volume Room, register value = m <sup>3</sup> * 1000, bbl * 100, gal * 100

**Table E-4: Tank Register Area (continued)**

Register Number	Register Name	Type	Unit	Description
6656-6783	Tank Shell Temp Correction	DWORD		Tank Shell Temperature Correction (CTSh), register value = CTSh * 1000000
6784-6911	Floating Roof Adjustment	DWORD		Floating Roof Adjustment, register value = m3 * 1000, bbl * 100, gal * 100
6912-7039	Gross Observed Volume	DWORD	NA	Gross observed volume, register value = m3 * 1000, bbl * 100, gal * 100
7040-7167	Gross Standard Volume	DWORD	NA	Gross standard volume, register value = m3 * 1000, bbl * 100, gal * 100
7168-7295	Net Standard Volume	DWORD	NA	Net standard volume, register value = m3 * 1000, bbl * 100, gal * 100
7296-7423	Weight in Air	DWORD	NA	Weight in air, register value = ton * 1000, kg, lb
7424-7551	Weight in Vacuum	DWORD	NA	Weight in vacuum, register value = ton * 1000, kg, lb
7552-7679	Vapor Liquid Volume	DWORD	NA	Vapor liquid volume for LPG tanks, register value = m3 * 1000, bbl * 100, gal * 100
7680-7807	Vapor Mass	DWORD	NA	Vapor mass for LPG tanks, register value = "ton * 1000", kg, lb. Default Mass in vacuum is calculated, can be changed via Inventory Calculation Mode register.
7808-8319	Product Mass	DWORD	NA	Product mass for LPG tanks, register value = "ton * 1000", kg, lb. Default Mass in vacuum is calculated, can be changed via Inventory Calculation Mode register.
8320-8447	Inventory Status	DWORD	NA	Bitfield: 0: Invalid Obs Density 1: Invalid Ref Density 2: Invalid CTPL 6: Invalid Flow Rate 7: Invalid FWV 8: Invalid TOV 9: Invalid AVR 10: Invalid PV 11: Invalid CTSH 12: Invalid FRA 13: Invalid GOV 14: Invalid GSV 15: Invalid NSV 16: Invalid WIA 17: Invalid WIV 18: Invalid Vapor Liq Volume 19: Invalid Vapor Mass 20: Invalid Product Mass

**Table E-4: Tank Register Area (continued)**

Register Number	Register Name	Type	Unit	Description
8448-8511	Floating Roof State	WORD	NA	SENUM: 0: Roof resting on leg 1: Roof partly floating 2: Roof freely floating 65535: Invalid roof state Floating Roof State: Resting on legs, Partly floating, Freely floating
8512-8575	Extended Inventory Status	WORD	NA	
	<b>Unit Register Area</b>			
9344-9407	User Defined 1 Unit	WORD		Priority 5 question.
9408-9471	User Defined 2 Unit	WORD		This register will define the unit for the User Defined 1 value above. The unit can be one of the following: Level Unit Temperature Unit Pressure Unit Density Unit Flow Rate Unit 39 = mA 57 = Percent % No unit
9472-9535	User Defined 3 Unit	WORD		
9536-9599	User Defined 4 Unit	WORD		
9600-9663	User Defined 5 Unit	WORD		
	<b>Diagnostic Register Area</b>			
9984-10111	Diagnostic Level Device Status	DWORD	Bitfield	Bit 7: Device Error Bit 11: Unknown Unit Bit 15: Invalid Level Bit16: Servo_CMD_bit0 Bit 17: Servo_CMD_bit1 Bit 18: Servo_CMD_bit2 Bit 19: Servo_CMD_bit3 Servo command bits, bit16 to 19: (0000)=None (0001)=Freeze (bit 16 =1) (0010)=Motor limit (bit 17 = 1) (0011)=Water search (bits 16 & 17 = 1) (0100)=Lock test (bit 18 = 1) (1001)=Density scan (16 & 19 = 1) (1010)=Test (bits 17 & 19 = 1) (1110)=Water (bits 17, 18 & 19 = 1) (1111)=Unknown (bits 16, 17, 18, 19 =1)
10112-10239	Diagnostic Temp Device Status	DWORD	Bitfield	Bit 7: Device Error Bit11: Unknown Unit Bit 15: Invalid Temperature
10240-10303	Level Signal Strength	WORD	mV	Used for radar gauges connected to Rosemount 2410 Tank Hub

## E.4.2 Floating roof monitoring input register area

Table E-5: Floating Roof Monitoring Input Register Area

Register Number	Register Name	Type	Unit	Description
	<b>FRM Config</b>			
22000	FRM Config TK32	DWORD	NA	Bitfield indicating tanks with enabled Floating Roof Monitoring (TK-1 to TK-32). Bitfield: Bit 0: TK-1 Bit 31: TK-32
22002	FRM Config TK64	DWORD	NA	Bitfield indicating tanks with enabled Floating Roof Monitoring (TK-33 to TK-64). Bitfield: Bit 0: TK-33 Bit 31: TK-64
	<b>FRM Alert</b>			
22004	FRM Alert TK32	DWORD	NA	Bitfield indicating active Floating Roof Monitoring alerts and invalid calculation. See individual tank for more information about the alert (TK-1 to TK-32). Bitfield: Bit 0: TK-1 Bit 31: TK-32
22006	FRM Alert TK64	DWORD	NA	Bitfield indicating active Floating Roof Monitoring alerts and invalid calculation. See individual tank for more information about the alert (TK-33 to TK-64). Bitfield: Bit 0: TK-33 Bit 31: TK-64
	<b>FRM Tank</b>			
22010	FRMTK1-Status	DWORD		Bitfield indicating Floating Roof Monitor status. Bitfield: Bit 0: Roof Tilt Monitoring Active Bit 1: Roof Tilt Invalid Bit 2: Roof Tilt High Alert Bit 4: Roof Floating Monitoring Active Bit 5: Roof Floating Invalid Bit 6: Roof Floating High Alert Bit 7: Roof Floating Low Alert Bit 8: Roof Resting On Legs Bit 16: Tilt Gauge 1 Invalid Bit 17: Tilt Gauge 2 Invalid Bit 18: Tilt Gauge 3 Invalid



## E.4.3 System register area

**Table E-6: System Register Area**

Register Number	Register Name	Type	Unit	Description
	<b>2460 Status Register Area</b>			Priority 5 question. Defines the unit for values in the FC04 area.
24000	Device Status	DWORD	NA	Bitfield: Bit 0: Simulation Mode Active Bit 1: Device Warning Bit 2: Device Error Bit 3: SW Write Protection Active Bit 4: HW Write Protection Active Bit 5: CDB Locked Bit 10: Redundant System Bit 11: Redundant Primary Device Bit 12: Redundant Active Device
24002	Device Error	DWORD	NA	Bitfield: Bit 0: Firmware Error Bit 1: CDB Error Bit 7: IPC Error Bit 14: SW Error Bit 17: Internal System Error Bit 18: License Error
24004	Device Warning	DWORD	NA	Bitfield: Bit 0: Firmware Warning Bit 1: CDB Warning Bit 4: Redundancy Warning Bit 5: Modem Warning Bit 14: Battery Warning Bit 15: USB Warning Bit 16: SD-Card Warning Bit 17: Internal System Warning Bit 18: License Conflict
24006	Device Operation Mode	WORD	NA	SENUM: 0 = Full Mode 1 = Warning Mode 2 = Error Mode
24010	Ambient Air Temperature	FLOAT	NA	
24012	Ambient Air Temperature Status	DWORD	NA	Bitfield: 0: Simulated Value 1: Manual Value 2: Invalid Value 3: CFail 4: MI Approved 5: MI Legal 6: Backup value used



**Table E-6: System Register Area (continued)**

Register Number	Register Name	Type	Unit	Description
24014	Ambient Air Temperature Update Counter			--
24016	Ambient Air Pressure	FLOAT	NA	Ambient air pressure. Special function to apply absolute pressure unit.
24018	Ambient Air Pressure Status	DWORD	NA	Bitfield: 0: Simulated Value 1: Manual Value 2: Invalid Value 3: CFail 6: Backup value used
24020	Ambient Air Pressure Update Counter	WORD	#	
24500	User defined 1 Value	FLOAT	NA	
	---			
24562	User defined 32 Value	FLOAT	NA	
24564	User defined 1 Status	DWORD		Bitfield: 0: Simulated Value 1: Manual Value 2: Invalid Value 3: CFail
	---			
24626	User defined 32 Status	DWORD		Bitfield: 0: Simulated Value 1: Manual Value 2: Invalid Value 3: CFail
24628	User defined 1 Update Counter	WORD	#	
	---			
24659	User defined 32 Update Counter	WORD	#	

**Table E-6: System Register Area (continued)**

Register Number	Register Name	Type	Unit	Description
24660	User defined 1 Unit	WORD	NA	SENUM: 11: Pa 12: kPa 17: Liter/minutes 19: m3/h 32: Deg C 33: Deg F 39: mA 40: US Gallon 41: Liter 43: m3 44: ft 45: m 46: Barrels 57: Percent 61: kg 62: ton (m) 63: lb 64: ton (s) 65: ton (l) 90: 60/60 Deg F 92: kg/m3 93: lb/gal(US) 96: kg/l 104: degAPI 120: m/h 134: bbl/h 136: US Gallon/h 239: mmH2O 247: ft/h 262: Psi A 263: Bar A 267: Pa A 268: kPa A 495: mmH2O A 518: Psi G 519: Bar G 523: Pa G 524: kPa G 751: mmH2O G 65535: Unknown
	---			
24691	User defined 32 Unit	WORD	NA	See register no. 24660

## E.4.4 Redundancy register area

**Table E-7: Redundancy Register Area**

Register Number	Register Name	Type	Unit	Description
	<b>Redundancy Information</b>			
30038	Redundancy information	DWORD	NA	0: Primary Status Warning 1: Backup Status Warning 8: Lost Connection To Remote 10: Redundant System 11: Primary Device 12: Active Device
	<b>Redundancy - Primary</b>			
30040	Redundancy status of primary device	DWORD	NA	0:Device Error 2: Modem Error Field Port 3: Modem Error Host Port 4: Modem Error Cfail to all devices on port 5: No HB and lost Host replies above limit 6: Lost Host replies above limit 7: Active do not request any Field Port 8: Active do not request Field Port 9: No active MBTCP Host communication 20: NTP Inactive Warning
30042	Device status of primary device	DWORD	NA	0: Simulation Mode Active 1: Device Warning 2: Device Error 3: SW Write Protection Active 4: HW Write Protection Active 5: CDB Locked 10: Redundant System 11: Primary Device 12: Active Device
30044	Device error of primary device	DWORD	NA	0: Firmware Error 1: CDB Error 7: IPC Error 14: SW Error 17: Internal System Error 18: License Error

**Table E-7: Redundancy Register Area (continued)**

Register Number	Register Name	Type	Unit	Description
30046	Device warning of primary device	DWORD	NA	0: Firmware Warning 1: CDB Warning 4: Redundancy Warning 5: Config Warning 14: Battery Warning 15: USB Warning 16: SD-Card Warning 17: Internal System Warning 18: License Warning
30050	Device ID of the primary redundant device		NA	
	<b>Redundacy - Backup</b>			
30070	Redundancy status of backup device	DWORD	NA	0: Device Error 2: Modem Error Field Port 3: Modem Error Host Port 4: Modem Error Cfail to all devices on port 5: No HB and lost Host replies above limit 6: Lost Host replies above limit 7: Active do not request any Field Port 8: Active do not request Field Port 9: No active MBTCP Host communication 20: NTP Inactive Warning
30072	Device status of backup device	DWORD	NA	0: Simulation Mode Active 1: Device Warning 2: Device Error 3: SW Write Protection Active 4: HW Write Protection Active 5: CDB Locked 10: Redundant System 11: Primary Device 12: Active Device

**Table E-7: Redundancy Register Area (continued)**

Register Number	Register Name	Type	Unit	Description
30074	Device error of backup device	DWORD	NA	0: Firmware Error 1: CDB Error 7: IPC Error 14: SW Error 17: Internal System Error 18: License Error
30076	Device warning of backup device	DWORD	NA	0: Firmware Warning 1: CDB Warning 4: Redundancy Warning 5: Config Warning 14: Battery Warning 15: USB Warning 16: SD-Card Warning 17: Internal System Warning 18: License Warning
30080	Device ID of the backup redundant device		NA	

## E.4.5 Simulation register area

**Table E-8: Simulation Register Area**

Register Number	Register Name	Type	Unit	Description
31100	Simulation-SimActive	WORD	NA	Simulation, 0=Not active, 1=Active 0 = inactive 1 = active
31101	Simulation-SimMode	WORD	NA	Simulation mode 0 = single 1 = all tanks
31102	Simulation-SimTank	WORD	NA	Tank to simulate values for (if mode=One_tank)
31104	Simulation-SimTimeLeft	DWORD	NA	Time left of simulation. If 0 and simulation is Active the simulation will be active until stopped by command or 2460 System Hub restart.

## E.4.6 Inventory register area

Table E-9: Inventory Register Area

Register Number	Register Name	Type	Unit	Description
	<b>Inventory Register Area</b>			
35200-35455	Observed Density	DOUBLE	kg/m <sup>3</sup> , API	Priority 3 question
35456 -35711	Reference Density	DOUBLE	kg/m <sup>3</sup> , API	
35712-36735	CTPL	DOUBLE		Correction for temperature and pressure of the liquid used to convert <b>Observed Density to Reference Density.</b>
36736-36991	Flow Rate	DOUBLE	m <sup>3</sup> /h, bbl/h	Priority 1 question
36992-37247	Free Water Volume	DOUBLE	m <sup>3</sup> , bbl	
37248-37503	Total Observed Volume	DOUBLE	m <sup>3</sup> , bbl	
37504-37759	Available Volume Room	DOUBLE	m <sup>3</sup> , bbl	
37760-38015	Pumpable Volume	DOUBLE	m <sup>3</sup> , bbl	
38016-38271	Tank Shell Temperature Correction	DOUBLE		
38272-38527	Floating Roof Adjustment	DOUBLE	m <sup>3</sup> , bbl	
38528-38783	Gross Observed Volume	DOUBLE	m <sup>3</sup> , bbl	
38784-39039	Gross Standard Volume	DOUBLE	m <sup>3</sup> , bbl	
39040-39295	Net Standard Volume	DOUBLE	m <sup>3</sup> , bbl	
39296-39551	Weight in Air	DOUBLE	ton (m)	
39552-39807	Weight in Vacuum	DOUBLE	ton (m)	
39808-40063	Vapor Liquid Volume	DOUBLE	m <sup>3</sup> , bbl	Vapor converted to liquid volume for LPG tank
40064-40319	Vapor Mass	DOUBLE	ton (m)	Vapor weight for LPG tank
40320-40827	Product Mass	DOUBLE	ton (m)	Product weight for LPG tank

## E.5 User defined Modbus server mapping

The system hub can be configured for a user defined Modbus map. This is useful when connecting the system hub to a third party host without changing the host configuration.

The 64 tank values in the system hub will be mapped to the **User Defined Modbus Server Input Register Modbus** interface. This is a file that can be created from a MS Excel spreadsheet and uploaded to the system hub.

Figure E-1: User Defined Modbus Server

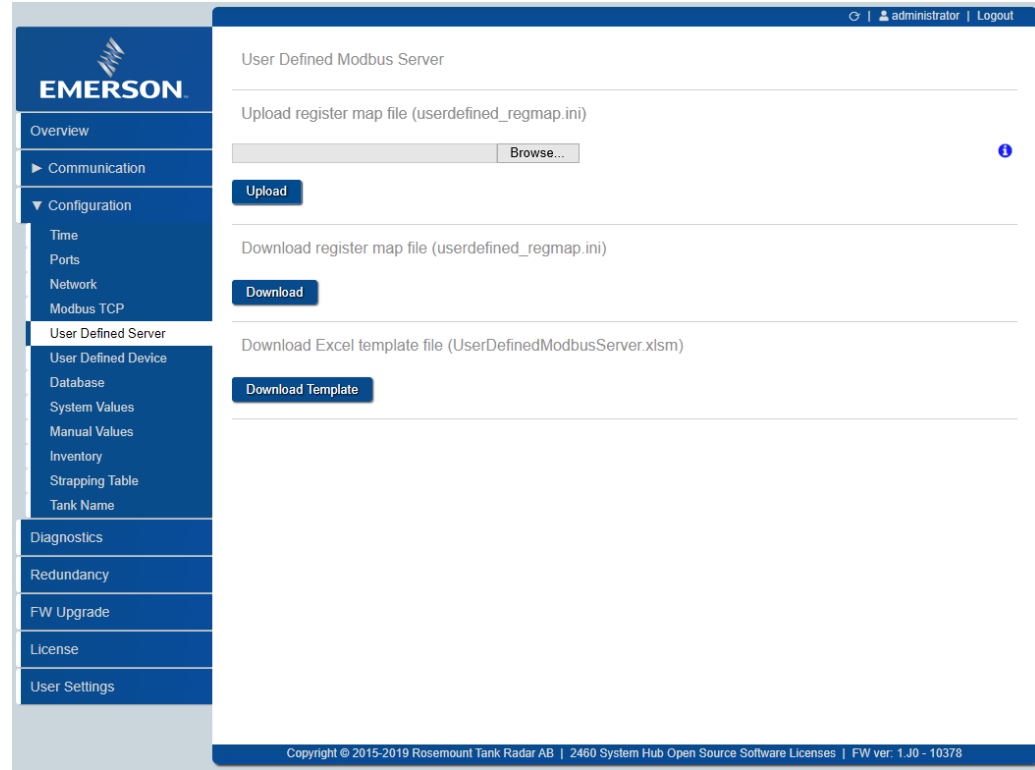

### Procedure

1. In the Web interface, click the **Download Template** button to download a MS Excel template file (UserDefinedModbusServer.xlsm).
2. In the Excel template file, edit the desired registers, or add new registers, and save the file.
3. From the template file, create a new register map file by clicking the **Export to map file userdefined\_regmap.ini** button.
4. In the Web interface, upload the `userdefined_regmap.ini` file to the system hub by clicking the **Upload** button.

### E.5.1 Upload and download register map file

The **Download** button lets you download the current Modbus register file in case you would like to edit or save a backup copy. The **Upload** button lets you upload a Modbus input register \*.ini file to the system hub register area.



## E.5.2 Download Excel template file

The **Download Template** button lets you download a file in MS Excel format to be used as a template for editing and creating a Modbus register map file. Once the Excel file is edited you can create a new User Defined Modbus register map \*.ini file which can be uploaded to the system hub.

## E.5.3 Editing the Excel template

The Excel file has two register sections that you can choose from depending on how host system queries are specified.

The register section that you will use must be placed at the beginning of the spread sheet, and there must be at least five empty rows after the register section. Information after the five empty rows will be ignored by the script that creates the new \*.ini file.

Once the Excel file is ready, press the **Export to map file...** button. Then a new register map \*.ini file is created which can be uploaded vi the system hub's web graphical interface.

Ensure that there are at least five empty rows after **Section End**.

### Related information

[Upload and download register map file](#)

### Register number section

One of the register sections is based on a list of separate register numbers as illustrated in [Figure E-2](#). This will be suitable in case the host system requests data for one tank at a time.

The page lets you edit existing registers and add new registers.

**Figure E-2: Register Number Section**

Register Number or Register Range	Section Size	Section Range	Parameter Name	Type	Special function	Special function Argument	Unit
<b>Tank</b>							
<b>Section Start</b>		16	64				
0			Level	FLOAT			LEVEL_UNIT
2			LevelRate	FLOAT			LEVELRATE_UNIT
4			Ullage	FLOAT			LEVEL_UNIT
6			FreeWaterLevel	FLOAT			LEVEL_UNIT
8			AvgProductTemp	FLOAT			TEMP_UNIT
10			AvgVaporTemp	FLOAT			TEMP_UNIT
12			Level	WORD	USER_DEF_STATUS_ZERO_OK	0xFFFF	NONE
13			Level	WORD	USER_DEF_STATUS_ZERO_LEGAL	0xFFFF	NONE
14			AvgProductTemp	WORD	USER_DEF_STATUS_ZERO_OK	0xFFFF	NONE
15			AvgVaporTemp	WORD	USER_DEF_STATUS_ZERO_OK	0xFFFF	NONE
<b>Section End</b>							
All information below 4 empty lines will be skipped by the script. Rows without register number will be skipped by the script.							

Once editing is done, you will have to verify that **Section Size** is correct. Section Size is automatically calculated and refers to the number of registers based on the first and last register in the list. In the example shown in [Figure E-3](#), **Section Size** is equal to 22.

Enter number of tanks in the **Section Range** field (16 in the example shown [Figure E-3](#)).

Figure E-3: Register Number Section for the Edited File

Register Number or Register Range	Section Size	Section Range	Parameter Name	Type	Special function	Special function Argument	Unit
<b>Tank</b>							
Section Start		22	16				
0			Level	WORD			MM
1			LevelRate	SWORD			CMH
2			Ullage	WORD			MM
3			FreeWaterLevel	WORD			MM
4			AvgProductTemp	SWORD			TEMP_UNIT
5			AvgVaporTemp	SWORD			TEMP_UNIT
6			Level	WORD	USER_DEF_STATUS_ZERO_OK	0x0001	NONE
7			Level	WORD	USER_DEF_STATUS_ZERO_LEGAL	0x0002	NONE
8			AvgProductTemp	WORD	USER_DEF_STATUS_ZERO_OK	0x0010	NONE
9			AvgVaporTemp	WORD	USER_DEF_STATUS_ZERO_OK	0x0020	NONE
10			Observed Density	FLOAT	USER_DEF_INVENTORY_VALUE		KG/M3
12			Flow Rate	FLOAT	USER_DEF_INVENTORY_VALUE		M3/H
14			Total Observed Volume	DWORD	USER_DEF_INVENTORY_VALUE		M3
16			Net Standard Volume	DWORD	USER_DEF_INVENTORY_VALUE		M3
18			Flow Rate	WORD	USER_DEF_STATUS_ZERO_OK	0x0100	NONE
19			Observed Density	WORD	USER_DEF_STATUS_ZERO_OK	0x0200	NONE
20			Total Observed Volume	WORD	USER_DEF_STATUS_ZERO_OK	0x0400	NONE
21			Net Standard Volume	WORD	USER_DEF_STATUS_ZERO_OK	0x0800	NONE
Section End							

### Register range section

The other section is organized in register ranges as illustrated in Figure E-4. This is suitable for host systems that queries one parameter at a time for a range of tanks. Figure E-4 illustrates an example of register range for 64 tanks.

Figure E-4: Register Range Section

Register Number or Register Range	Section Size	Section Range	Parameter Name	Type	Special function	Special function Argument	Unit	Comment
<b>Tank</b>								
Register Range Start								
0-127			Level	FLOAT			FT	Level value for tank 1 - 64
128-255			LevelRate	FLOAT			FT/H	Level rate value for tank 1 - 64
256-383			FreeWaterLevel	FLOAT			FT	FWL value for tank 1 - 64
384-512			AvgProductTemp	FLOAT			F	Avg temp value for tank 1 - 64
512-767			Flow Rate	DOUBLE	USER_DEF_INVENTORY_VALUE		BB/LH	Flow Rate value for tank 1 - 64
768-1023			Free Water Volume	DOUBLE	USER_DEF_INVENTORY_VALUE		BB/L	FWV value for tank 1 - 64
1024-1279			Total Observed Volume	DOUBLE	USER_DEF_INVENTORY_VALUE		BB/L	TOV value for tank 1 - 64
1280-1535			Net Standard Volume	DOUBLE	USER_DEF_INVENTORY_VALUE		BB/L	NSV value for tank 1 - 64
1536-1791			Weight In Vacuum	DOUBLE	USER_DEF_INVENTORY_VALUE		TON S	WV value for tank 1 - 64
4096-4189			Level	WORD	USER_DEF_STATUS_ZERO_OK	0x00FF	NONE	Level status for tank 1 - 64
4190-4223			FreeWaterLevel	WORD	USER_DEF_STATUS_ZERO_OK	0x00FF	NONE	FWL status for tank 1 - 64
4224-4287			AvgProductTemp	WORD	USER_DEF_STATUS_ZERO_OK	0x00FF	NONE	Avg temp status for tank 1 - 64
4288-4351			Total Observed Volume	WORD	USER_DEF_STATUS_ZERO_OK	0xFF00	NONE	TOV status for tank 1 - 64
4352-4415			Net Standard Volume	WORD	USER_DEF_STATUS_ZERO_OK	0xFF00	NONE	NSV status for tank 1 - 64
4416-4479			Weight In Vacuum	WORD	USER_DEF_STATUS_ZERO_OK	0xFF00	NONE	WV status for tank 1 - 64
4480-4543			RelayStatus	WORD	USER_DEF_RELAY_STATUS_ZERO_NOT_ENERGIIZED	0x001000FF	NONE	Relay1 status for tank 1 - 64
4544-4608			RelayStatus	WORD	USER_DEF_RELAY_STATUS_ZERO_NOT_ENERGIIZED	0x000200FF	NONE	Relay2 status for tank 1 - 64
Register Range End								

## E.6 User defined Modbus device mapping

This option lets you map device input registers to a Rosemount 2460 System Hub's tank variables and parameters.

Mapping is done by using a file that can be created from a MS Excel spread sheet and uploaded to the system hub.

Figure E-5: User Defined Modbus Device

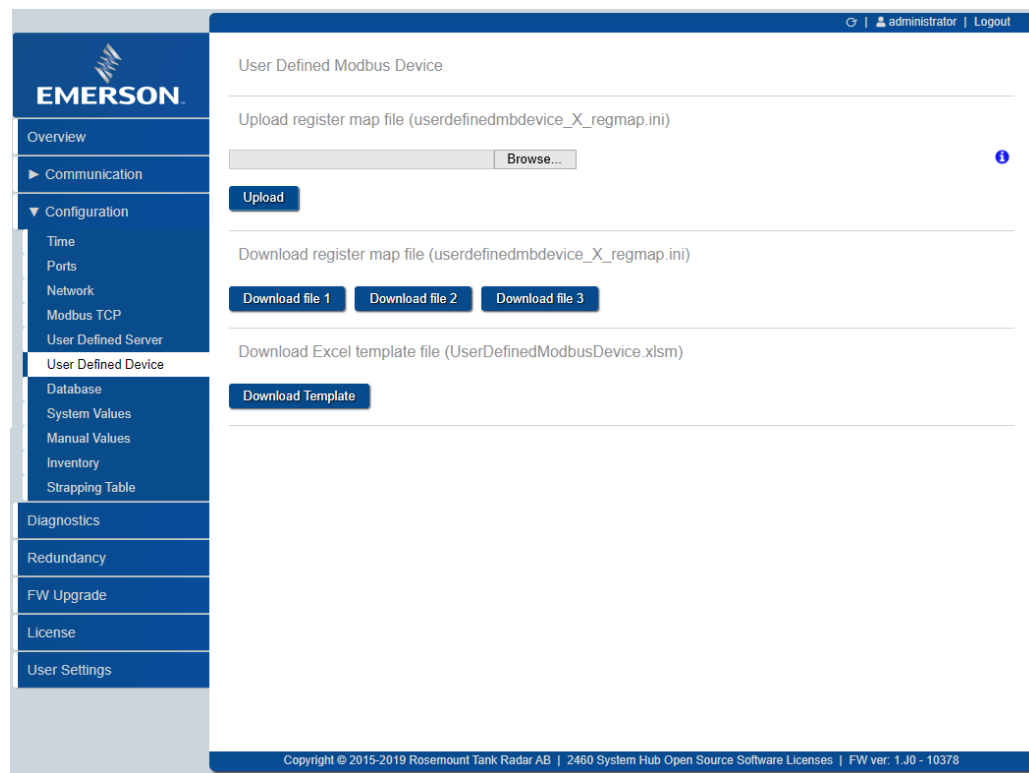

### Procedure

1. In the Web interface, click the **Download Template** button to download a MS Excel template file (UserDefinedModbusDevice.xlsm).
2. Edit the desired registers, or add new registers, and save the Excel file.
3. From the Excel file, create a new register map file by clicking the **Export to map file userdefinedmbdevice\_X\_regmap.ini** button.
4. Upload the `userdefinedmbdevice_X_regmap.ini` file to the system hub by clicking the **Upload** button.

### E.6.1 Upload and download register map file

The **Download** button lets you download the current Modbus register file in case you would like to edit or save a backup copy. The **Upload** button lets you upload a Modbus input register \*.ini file to the system hub register area.

## E.6.2 Download Excel template file

The **Download Template** button lets you download a file in MS Excel format to be used as a template for editing and creating a Modbus register map file. Once the Excel file is edited you can create a new User Defined Modbus register map \*.ini file which can be uploaded to the system hub.

# F Fast polling

## F.1 Overview

This section describes how to enable and configure fast polling for devices that support this function. Fast polling can be used to increase the sampling rate for tanks with level rates above a certain threshold value. Two fast polling options are supported:

**Table F-1: Fast Polling Options**

Option	Description
Common Settings	A general threshold setting that applies for all servo tanks. See <a href="#">Configure fast polling with common threshold</a> .
Individual Settings	Individual threshold values for different tanks. See <a href="#">Configure fast polling with individual thresholds</a> .

## F.2 Configure fast polling with common threshold

A general threshold setting can be configured which applies for all servo tanks.

### Procedure

1. Open TankMaster WinSetup.
2. In the WinSetup workspace, click the right mouse button on the Rosemount 2460 icon and choose **Properties**.

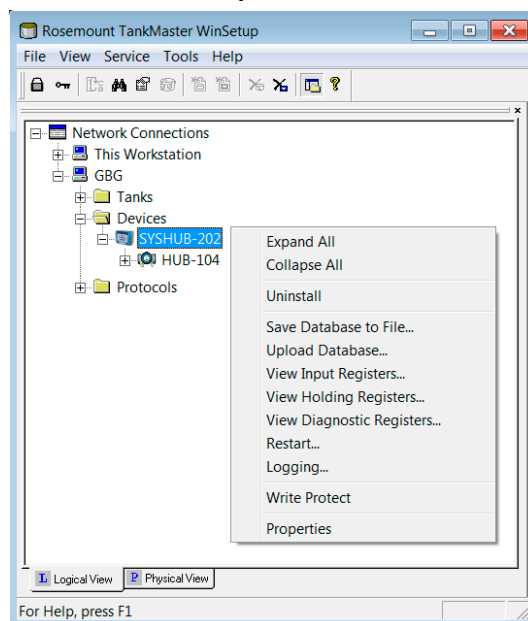

3. Select the **Advanced** tab and click the **Fast Polling** button.

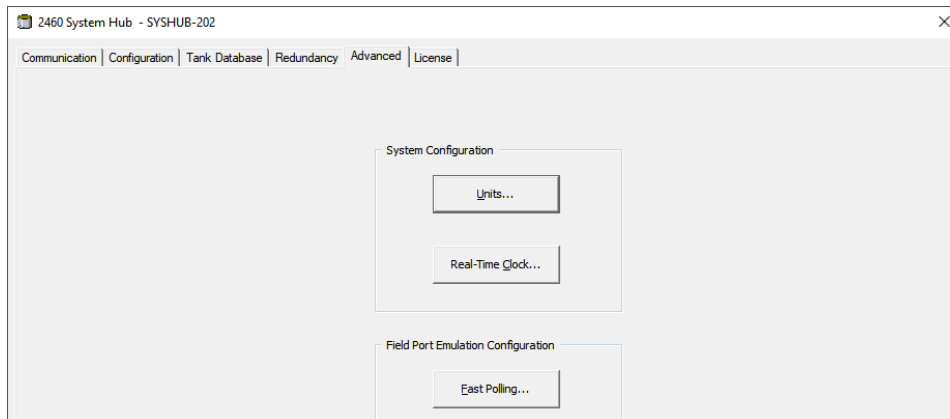

4. Choose the **Common Settings** option.

This option lets you apply the same level rate threshold for all servo tanks (“servo tank” means that Tank Type is set to one of the servo tank options available in the tank installation wizard).

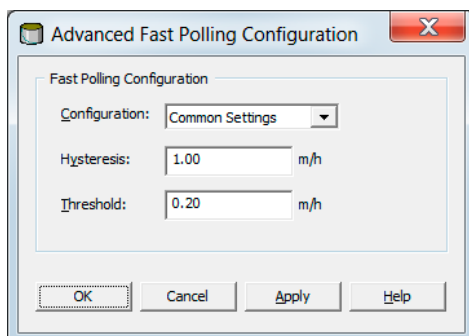

5. Enter the desired **Hysteresis** and **Threshold** values.

The **Hysteresis** variable lets you specify a zone in which Fast Polling is not changed from its current state. This prevents switching Fast Polling on and off when the level rate is changed only small amounts around a certain **Threshold** value.

6. Click **Apply** to save the current configuration.
7. Click **OK** to close the window.

## F.3 Configure fast polling with individual thresholds

### F.3.1 Enable individual settings

The Fast Polling function must be enabled before it can be configured for individual thresholds.

#### Procedure

1. Open TankMaster WinSetup.
2. Click the right mouse button on the Rosemount 2460 icon and choose **Properties**.

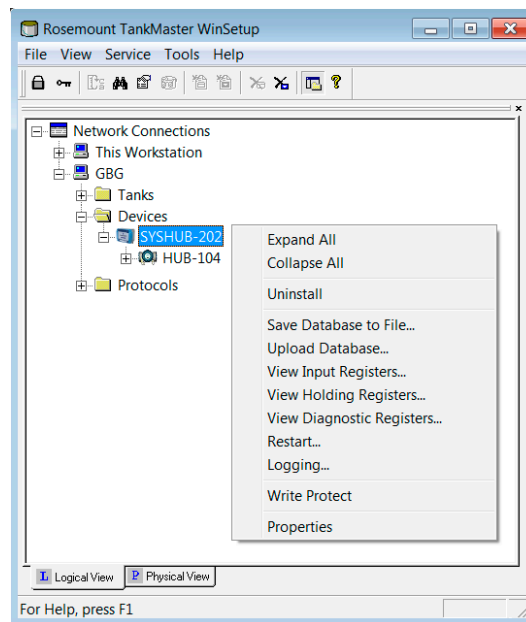

3. Select the **Advanced** tab and click the **Fast Polling** button.

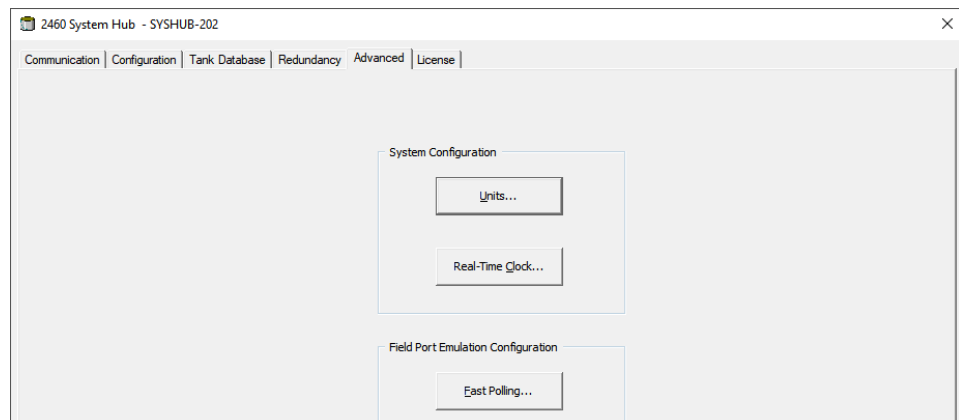

4. Choose the **Individual Settings** option.

This option lets you apply individual level rate thresholds for each servo tank (“servo tank” means that one of the servo tank options is used as Tank Type in the tank installation wizard).

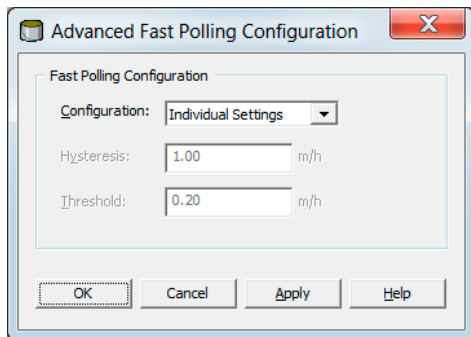

5. Click **Apply** to save the current configuration.
6. Click **OK** to close the window.

#### Postrequisites

Open the **Tank Database** window to configure fast polling with individual level rate thresholds for the desired tanks.

#### Related information

[Configure fast polling with individual settings](#)

## F.3.2 Configure fast polling with individual settings

It is possible to configure individual fast polling threshold values for different servo tanks.

#### Prerequisites

Ensure that Individual Settings is enabled.

#### Procedure

1. Open TankMaster WinSetup.
2. In the WinSetup workspace, click the right mouse button on the Rosemount 2460 icon and choose **Properties**.
3. Select the **Tank Database** tab.



- Click the **Advanced** button for the desired tank to open a configuration window. The configuration window lets you specify **Fast Polling** parameters for the selected tank.

2460 Tank	Source	Field Port	2410 Device Address	2410 Tank Pos	Level Device Address	Temp Device Address	Number of Temp Elements	VP	MP	LP	FWL	UIn1	UIn2	UIn3	UIn4	UIn5	Relays	Adv.
1	2410	1	101	1	1	101	6	VP	-	LP	-	-	-	-	-	-	-	-
2	2410	1	102	1	2	102	8	-	-	-	-	-	-	-	-	-	-	-
3	2410	1	103	1	3	103	8	-	-	-	FWL	-	-	-	-	-	-	-
4	2410	1	104	1	4	104	6	-	-	-	FWL	-	-	-	-	-	-	-
5	2410	1	105	1	5	105	6	-	-	-	-	-	-	-	-	-	-	-
6	Whessoe 550	2			6	6	0	-	-	-	-	-	-	-	-	-	-	-
7	Whessoe 660	3			7	7	0	-	-	-	-	-	-	-	-	-	-	-
8	Enraf 811	4			10	0	-	-	-	-	-	-	-	-	-	-	-	-
9	Enraf 813	4			11	0	-	-	-	-	-	-	-	-	-	-	-	-
10	Enraf 854	4			12	0	-	-	-	-	-	-	-	-	-	-	-	-
11	Enraf 873	4			13	0	-	-	-	-	-	-	-	-	-	-	-	-
12	(none)																	-

It may differ for various devices as shown below.

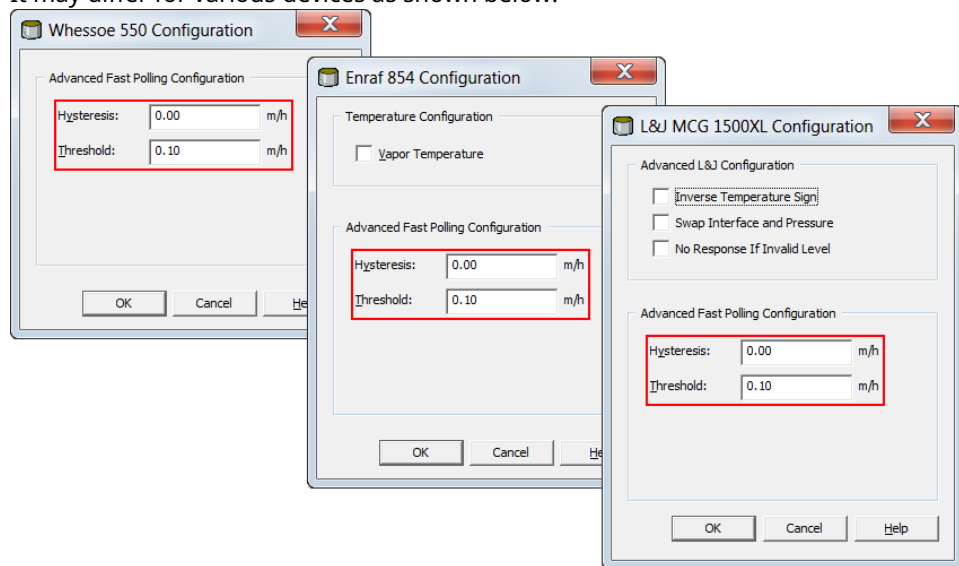

- Set the desired **Hysteresis** and **Threshold** values. These values will apply to the tank that was selected in the Rosemount 2460's tank database. Individual threshold settings can be configured for other tanks as well by using the **Advanced** button for those tanks.
- Press **OK** to save the current configuration and close the window.

#### Related information

[Enable individual settings](#)



# G L&J device configuration

## G.1 Tank Database configuration for L&J devices

This section describes how to configure the Rosemount 2460 System Hub's tank database for supported L&J devices.

### Procedure

1. In TankMaster WinSetup right-click the Rosemount 2460 System Hub that the device is connected to and select **Properties**.
2. Select the **Tank Database** tab.

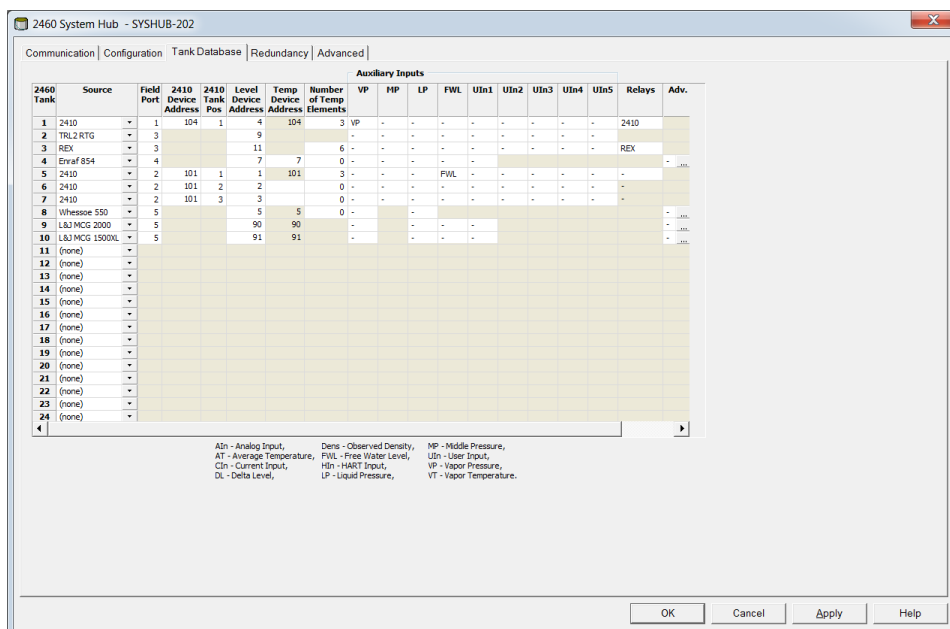

3. Find a free tank position (2460 Tank 1, 2, 3...) for the device to be configured.
4. In the **Source** field, choose the appropriate L&J device type.

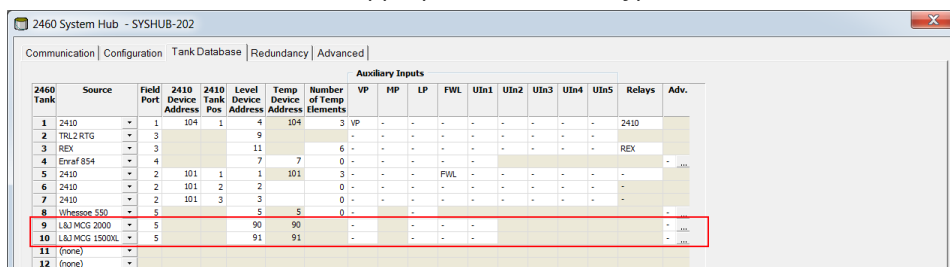

5. Select the **Field Port** that the device is connected to.  
Ensure that the port is equipped with the appropriate modem. In the standard configuration there are six field bus ports available for the Rosemount 2460 System Hub.
6. Enter the address of the gauge into the **Level Device Address** field.  
Each field device has its own unique address in the range 0-127.

7. The **Temp Device Address** field can not be edited. The address is automatically set to the address of the level device.
8. Select the **Auxiliary Inputs** that are used for the device.  
Vapor Pressure (VP), Liquid Pressure (LP), Free Water Level (FWL), and User Input 1 (UIn1) can be configured for L&J devices.

**Note**

Note that only one pressure parameter at a time may be chosen, i.e. either the VP or the LP parameter.

9. See [Advanced L&J configuration](#) for advanced options.

**Related information**

[L&J modem card](#)

[Connecting to a Rosemount 2460 System Hub](#)

[Tank Database entry fields for L&J devices](#)

## G.1.1

## Tank Database entry fields for L&J devices

**Table G-1: Summary of Tank Database Entry Fields**

Entry field	Description
Source	L&J Tankway <sup>(1)</sup> <ul style="list-style-type: none"> <li>• L&amp;J MCG 1500XL</li> <li>• L&amp;J MCG 2000</li> </ul>
Field Port	The field bus port that the selected device is connected to. Up to six field ports may be used.
Level Device Address	Level device address. Each field device has its own unique address in the range 0-127.
Temp Device Address	Automatically set to the same address as the level device.
Number of Temp Elements	Not applicable
Auxiliary Inputs	L&J Tankway <ul style="list-style-type: none"> <li>• Vapor Pressure</li> <li>• Liquid Pressure</li> <li>• Free Water Level</li> <li>• Observed Density (UIn1=Dens)</li> </ul>
Advanced	L&J Tankway <ul style="list-style-type: none"> <li>• Inverse Temperature Sign</li> <li>• Swap Interface and Pressure</li> <li>• No Response if Invalid Level</li> <li>• Fast polling</li> </ul>

*(1) L&J option is supported for 2460 firmware version 1.E0 and higher.*

## G.2

## Advanced L&J configuration

This section describes advanced configuration options for supported L&J devices.

## G.2.1 Fast polling

See [Fast polling](#) for information on how to setup fast polling.

## G.2.2 Advanced L&J configuration

### Procedure

1. Open the TankMaster WinSetup program.
2. In the WinSetup workspace, click the right mouse button on the Rosemount 2460 icon and select **Properties**.
3. Select the **Tank Database** tab.
4. For the desired L&J device tank position, press the **Advanced** button to open the **L&J Configuration** window.

2460 Tank	Source	Field Port	2410 Device Address	2410 Tank Pos	Level Device Address	Temp Device Address	Number of Temp Elements	VP	MP	LP	FWL	UIn1	UIn2	UIn3	UIn4	UIn5	Relays	Adv.
1	2410	1	104	1	4	104	3	VP	-	-	-	-	-	-	-	-	-	-
2	TRL2RTG	3			9													2410
3	REX	3			11		6											REX
4	Erraf854	4			7		7	0										
5	2410	2	101	1	1	101	3	-	-	-	FWL	-	-	-	-	-	-	
6	2410	2	101	2	2		0											
7	2410	2	101	3	3		0											
8	Whessoe 550	5			5	5	0											
9	L&J MCG 2000	5			90	90												
10	L&J MCG 1500XL	5			91	91												
11	(none)	-																
12	(none)	-																

5. Set the advanced L&J configuration parameters as desired.
6. Press **OK** to save the current configuration and close the configuration window.

## L&J configuration window

The **L&J Configuration** window lets you configure advanced options for the selected device.

Figure G-1: L&J Configuration Window

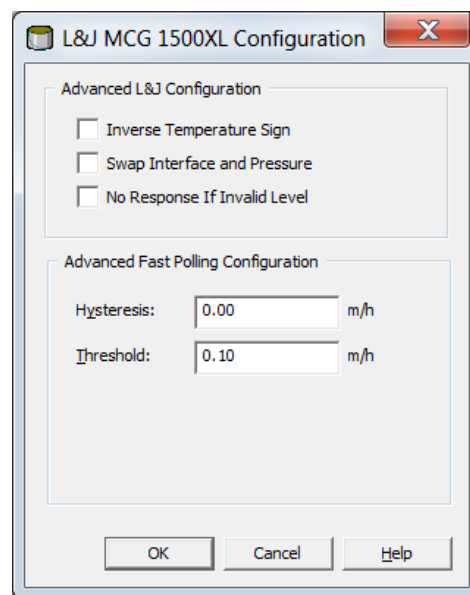

**Table G-2: Advanced L&J Configuration Options**

<b>Option</b>	<b>Description</b>
Inverse Temperature Sign	This option shifts sign for Average Liquid Temperature values. Use this option to match host system standards.
Swap Interface and Pressure	This option shifts interface and pressure data. Use this option to match host system standards.
No Response If Invalid Level	This option prevents invalid level data to result in communication failure (CFail) error message.

# H Varec® device configuration

## H.1 Tank Database configuration for Varec® devices

This section describes how to configure the Rosemount 2460 System Hub's tank database for supported Varec devices.

### Procedure

1. In TankMaster WinSetup right-click the Rosemount 2460 System Hub that the device is connected to and choose **Properties**.
2. Select the **Tank Database** tab.

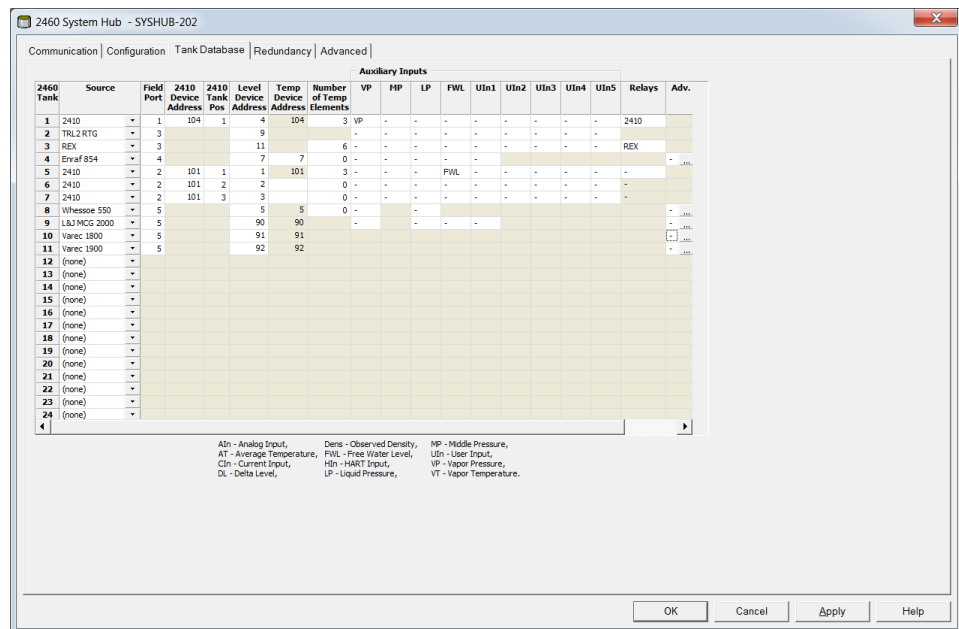

3. Find a free tank position (2460 Tank 1, 2, 3...) for the device to be configured.
4. In the **Source** field, choose the appropriate Varec device type.

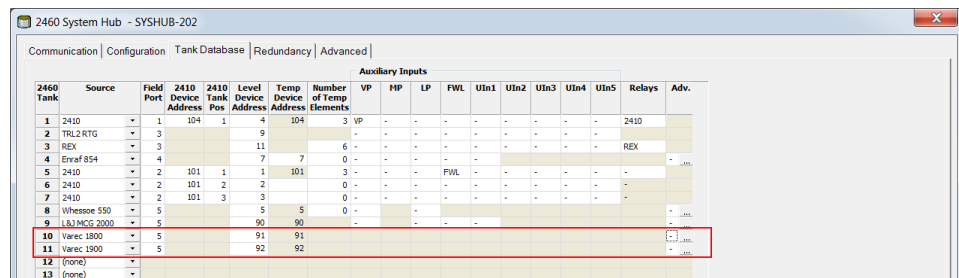

5. Select the **Field Port** that the device is connected to.  
Ensure that the port is equipped with the appropriate modem. In the standard configuration there are six field bus ports available for the Rosemount 2460 System Hub.

6. Enter the address of the gauge into the **Level Device Address** field.  
Each field device has its own unique address in the range 0-999.
7. The **Temp Device Address** field can not be edited. The address is automatically set to the address of the level device.
8. See [Advanced Varec configuration](#) for advanced options.

**Related information**

- [Varec modem card](#)
- [Connecting to a Rosemount 2460 System Hub](#)
- [Tank Database entry fields for Varec devices](#)

## H.1.1 Tank Database entry fields for Varec devices

**Table H-1: Summary of Tank Database Entry Fields**

Entry field	Description
Source	Varec Mark/Space <sup>(1)</sup>
Field Port	The field bus port that the selected device is connected to. Up to six field ports may be used.
Level Device Address	Level device address. Each field device has its own unique address in the range 0-999.
Temp Device Address	Use the same address as the level device.
Number of Temp Elements	Not applicable
Auxiliary Inputs	Varec Mark/Space <ul style="list-style-type: none"> <li>• None</li> </ul>
Advanced	Varec Mark/Space <ul style="list-style-type: none"> <li>• Level range</li> <li>• Temperature global offset</li> <li>• Measurement units</li> <li>• Fast polling</li> </ul>

*(1) Varec option is supported for Rosemount 2460 firmware version 1.E0 and higher.*



## H.2 Advanced Varec configuration

This section describes advanced configuration options for supported Varec devices.

### H.2.1 Fast polling

See [Fast polling](#) for information on how to setup fast polling.

### H.2.2 Advanced Varec configuration

#### Procedure

1. Open the TankMaster WinSetup program.
2. In the WinSetup workspace, click the right mouse button on the 2460 icon and select **Properties**.
3. Select the **Tank Database** tab.
4. To open the **Varec 1800/1900 Configuration** window, click the **Advanced** button for the desired Varec device.

2460 Tank	Source	Field Port	2410 Device Address	2410 Tank Pos	Level Device Address	Temp Device Address	Number of Temp Elements	VP	MP	LP	FWL	UIn1	UIn2	UIn3	UIn4	UIn5	Relays	Adv.
1	2410		1	104	1	4	104	3	VP	-	-	-	-	-	-	-	2410	
2	TRL2 RTG		3			9												
3	REX		3			11		6										REX
4	Evaf 854		4			7	7	0										
5	2410		2	101	1	1	101	3			FWL							
6	2410		2	101	2	2		0										
7	2410		2	101	3	3		0										
8	Whesase 550		5			5	5	0										
9	L&J MCC 2000		5			90	90											
10	Varec 1800		5			91	91											
11	Varec 1900		5			92	92											
12	(none)																	
13	(none)																	

5. Set the configuration parameters as desired.
6. Click **OK** to save the current configuration and close the configuration window.

#### Related information

[Fast polling](#)

### Varec 1800/1900 configuration window

The **Varec 1800/1900 Configuration** window lets you configure **level range** for the selected tank. Choosing the most appropriate range will optimize level measurement resolution.

You may also configure **temperature offset**, **measurement units**, as well as **fast polling**. Temperature Global Offset may be used to calibrate temperature output to a host system.

Figure H-1: Varec 1800/1900 Configuration Window

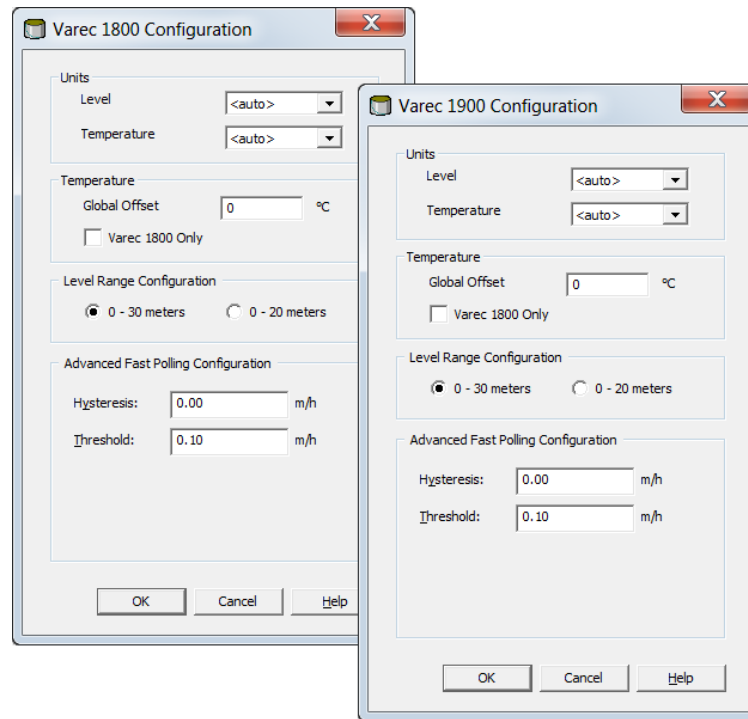

# I Enraf® 858 CIU configuration

## I.1 Introduction

A Rosemount 2460 System Hub can emulate an Enraf 858 CIU<sup>(12)</sup> on any of the available host ports<sup>(13)</sup>. With Enraf CIU 858 emulation, you can use a Rosemount 2460 System Hub together with an existing host control system. The system hub is transparent to the old host, passing information along to the field devices so the user will not even notice that the old CIU has been replaced.

This section describes how to configure the Enraf server functionality in Rosemount TankMaster.

The Enraf server ports can use RS-232 or RS-485 communication interface. However, note that the RS-232 interface can only be used on Port 7.

**Figure I-1: Rosemount 2460 System Hub Emulating an Enraf 858 CIU**

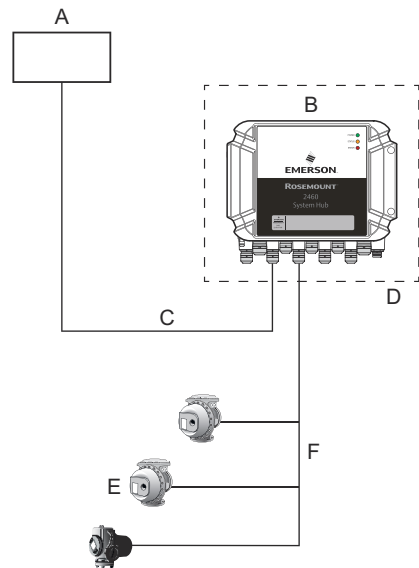

- A. Enraf host
- B. Rosemount 2460 System Hub
- C. RS232/RS485
- D. Enraf CIU 858 emulation
- E. Servo gauges
- F. Enraf BPM

### Related information

[Digital communication protocols](#)  
[Modem cards](#)

(12) Enraf 858 CIU emulation is supported from TankMaster 6.E0.

(13) Note that Host Port 8 is used for Rosemount TankMaster.

## I.2 Getting started

To setup the Rosemount 2460 System Hub for Enraf 858 CIU emulation:

### Procedure

1. Open the Rosemount TankMaster WinSetup configuration program.
2. Ensure that the Rosemount 2460 is properly installed<sup>(14)</sup> and appear in the WinSetup workspace as illustrated below.

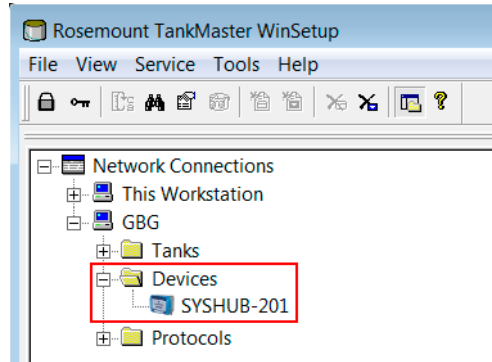

3. Click the right mouse button and select **Properties**.
4. Select the **Configuration** tab and configure the appropriate Host Port.

### Related information

[Host port configuration](#)

## I.3 Host port configuration

The **Configuration** window lets you setup communication ports for Enraf 858 CIU emulation.

### Procedure

1. In the TankMaster Winsetup workspace, click the right mouse button on the Rosemount 2460 icon.
2. Select **Properties** to open the system hub's configuration window.

<sup>(14)</sup> See [Configuration](#) for more information on how to setup the Rosemount 2460 System Hub.

- Identify the port that is used for the Enraf CIU 858 emulation.

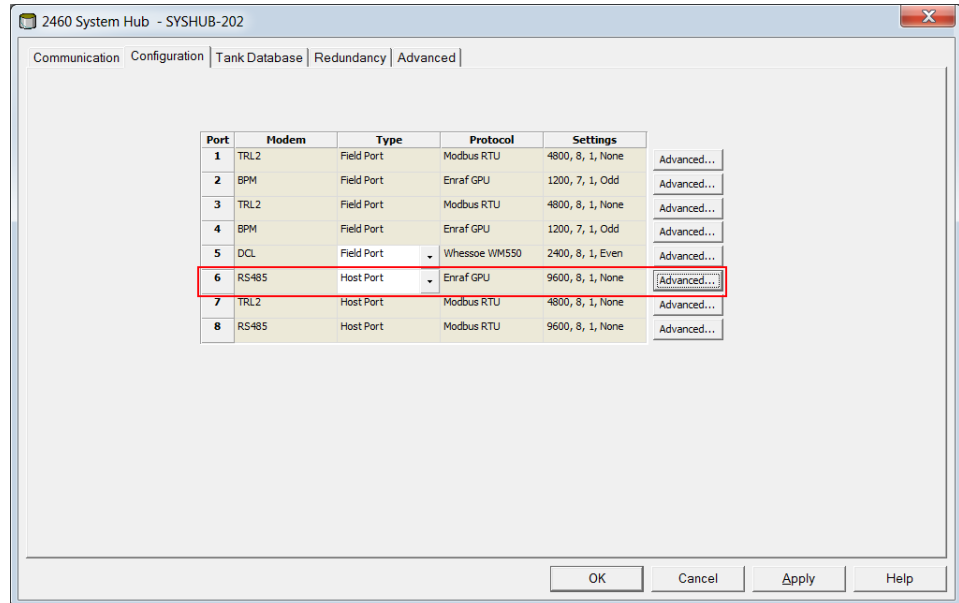

- In case port 5 or 6 is used for Enraf CIU 858 communication, verify that protocol type is **Host Port**. If not, select **Host Port** from the drop-down list.
- Verify correct Protocol and communication settings. Click the **Advanced** button if you need to change any communication settings.  
Note that Ports 5 and 6 can be used as either field or host ports. Ports 7 and 8 can be used as Host Ports only. In the default setup, ports 1 - 6 are configured as field ports. Note that only port 7 can be used for RS232 communication with the Enraf host.
- In the **Advanced Port Configuration** window, choose Protocol **Enraf GPU**.

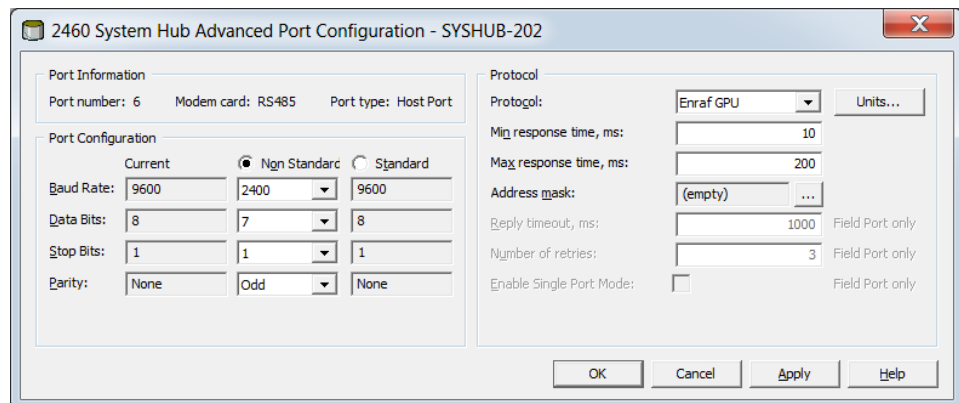

- In the **Port Configuration** pane, set communication parameters such as **Baud Rate** to the same as the Enraf host.

- In the **Address Mask** field, click the  button and select the desired Enraf CIU addresses.

The system hub only replies on selected addresses. A Rosemount 2460 may replace two Enraf CIU 858 with 30 devices each.

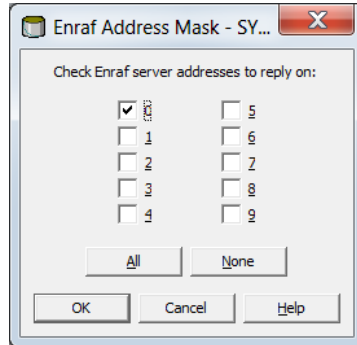

- Click the **Units** button to set the appropriate Enraf measurement units.

Auto is the default setting. In Auto mode Enraf units will be the same as the system hub units. It is recommended to select the Enraf units manually.

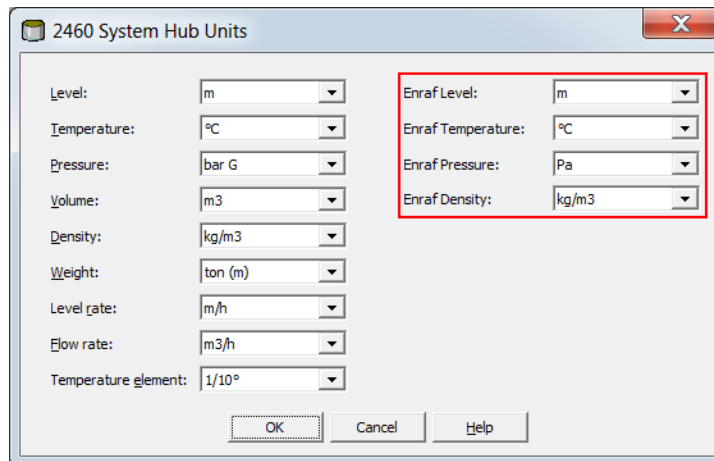

# J TIC configuration

## J.1 Tank Database configuration for TIC devices

This section describes how to configure the Rosemount™ 2460 System Hub's tank database for supported TIC devices.

### Procedure

1. In TankMaster WinSetup right-click the Rosemount 2460 System Hub that the device is connected to and select **Properties**.
2. Select the **Tank Database** tab.

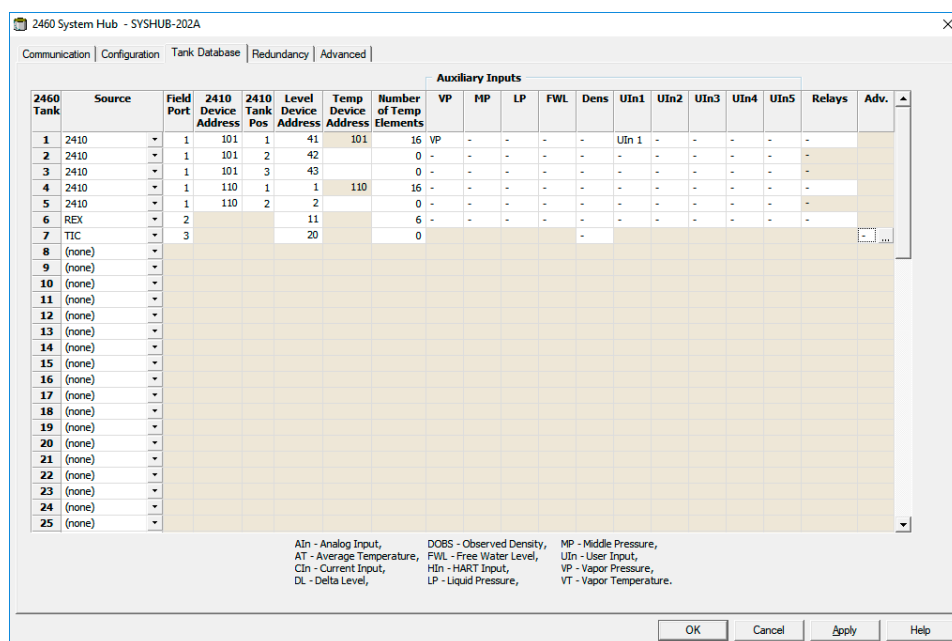

3. Find a free tank position (2460 Tank 1, 2, 3...) for the device to be configured.
4. In the **Source** drop-down list select TIC.

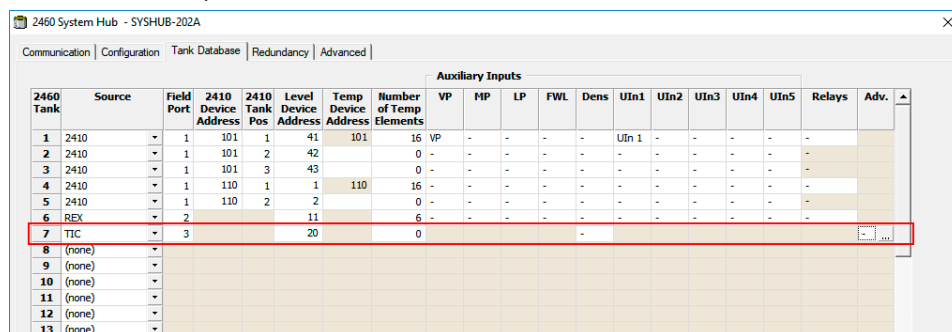

5. Ensure that the proper field port is selected and that the port is equipped with the appropriate modem.  
The standard configuration has six field bus ports.

6. Enter the address of the gauge into the **Level Device Address** field.  
Each field device has its own unique address.
7. The **Temp Device Address** field can not be edited. The address is automatically set to the address of the level device.
8. Select the **Auxiliary Input** for the device.  
Observed Density (Dobs) is available for TIC devices.
9. See [Advanced TIC device configuration](#) for advanced options.

**Related information**

[Modem cards](#)

[Connecting to a Rosemount 2460 System Hub](#)

[Tank Database entry fields for TIC devices](#)

## J.1.1

## Tank Database entry fields for TIC devices

**Table J-1: Summary of Tank Database Entry Fields**

Entry field	Description
Source	TIC <sup>(1)</sup>
Field Port	The field bus port that the selected device is connected to. Up to six field ports may be used.
Level Device Address	Level device address. Each field device has its own unique address in the range 0-255.
Temp Device Address	Automatically set to the same address as the level device.
Number of Temp Elements	"0" in case only average temperature is required. Otherwise the total number of connected temperature elements. In case you don't need to monitor values for individual temperature elements you should set this parameter to "0" in order to avoid unnecessary load on the field bus.
Auxiliary Inputs	<ul style="list-style-type: none"> <li>• Observed Density (DOBS)</li> </ul>
Advanced	<ul style="list-style-type: none"> <li>• Fast polling</li> </ul>

*(1) TIC option is supported for 2460 firmware version 1.E0 and higher.*

## J.2

## Advanced TIC device configuration

This section describes advanced configuration options for supported TIC devices.

### J.2.1

### Fast polling

See [Fast polling](#) for information on how to setup fast polling.



# K Sakura configuration

## K.1 Tank Database configuration for Sakura devices

This section describes how to configure the Rosemount 2460 System Hub's tank database for supported Sakura devices.

### Procedure

1. In TankMaster WinSetup right-click the Rosemount 2460 System Hub that the device is connected to and choose **Properties**.
2. Select the **Tank Database** tab.

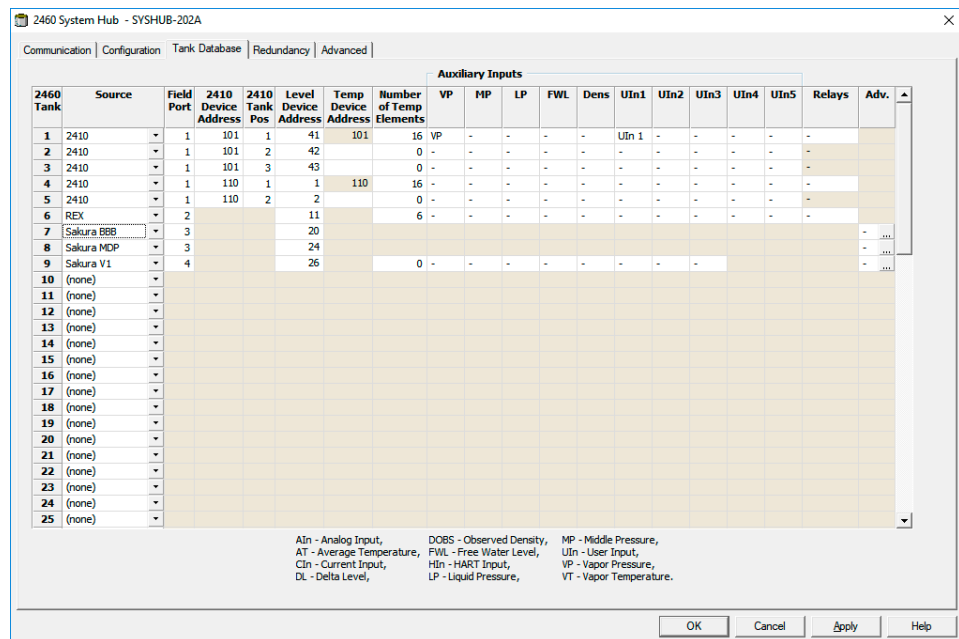

3. Find a free tank position (2460 Tank 1, 2, 3...) for the device to be configured.
4. In the **Source** field, choose the appropriate Sakura device type.

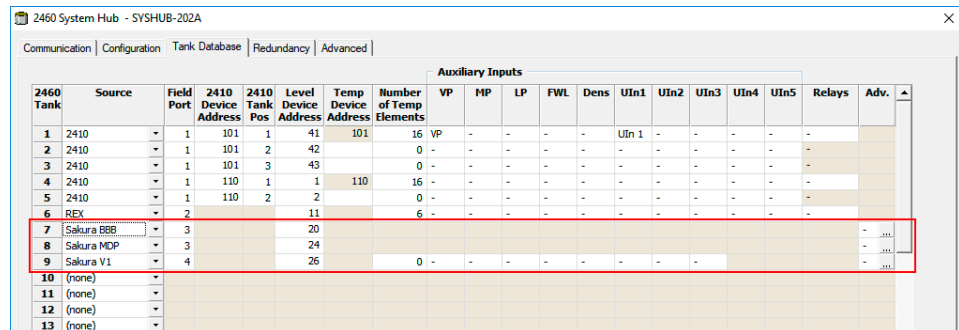

5. Select the **Field Port** that the device is connected to.  
Ensure that the port is equipped with the appropriate modem. In the standard configuration there are six field bus ports available for the Rosemount 2460 System Hub.

6. Enter the address of the gauge into the **Level Device Address** field.  
Each field device has its own unique address.
7. The **Temp Device Address** field can not be edited. The address is automatically set to the address of the level device.
8. Select the **Auxiliary Inputs** that are used for the device.
9. See [Advanced Sakura device configuration](#) for advanced options.

#### Related information

[Modem cards](#)

[Connecting to a Rosemount 2460 System Hub](#)

[Tank Database entry fields for Sakura devices](#)

## K.1.1 Tank Database entry fields for Sakura devices

**Table K-1: Summary of Tank Database Entry Fields**

Entry field	Description
Source	Sakura <sup>(1)</sup> : <ul style="list-style-type: none"> <li>• Sakura BBB</li> <li>• Sakura MDP</li> <li>• Sakura V1</li> </ul>
Field Port	The field bus port that the selected device is connected to. Up to six field ports may be used.
Level Device Address	Level device address. Each field device has its own unique address: <ul style="list-style-type: none"> <li>• Sakura MDP/BBB: 0-255</li> <li>• Sakura V1: 0-99</li> </ul>
Temp Device Address	Automatically set to the same address as the level device.
Number of Temp Elements	Sakura MDP/BBB: Not applicable. Sakura V1: "0" in case only average temperature is required. Otherwise the total number of connected temperature elements. In case you don't need to monitor values for individual temperature elements you should set this parameter to "0" in order to avoid unnecessary load on the field bus.
Auxiliary Inputs	Sakura V1: <ul style="list-style-type: none"> <li>• Vapor Pressure</li> <li>• Middle Pressure</li> <li>• Liquid Pressure</li> <li>• Free Water Level</li> <li>• Observed Density</li> <li>• HART1 (UIn1)</li> <li>• HART2 (UIn2)</li> <li>• Ain (UIn3)</li> </ul>
Advanced	Sakura V1: <ul style="list-style-type: none"> <li>• Vapor Temperature</li> <li>• Fast polling</li> </ul>

(1) Sakura option is supported for 2460 firmware version 1.E0 and higher.

## K.2 Advanced Sakura device configuration

This section describes advanced configuration options for supported Sakura devices.

### K.2.1 Fast polling

See [Fast polling](#) for information on how to setup fast polling.

### K.2.2 Advanced tank database configuration

#### Procedure

1. Open the TankMaster WinSetup program.
2. In the WinSetup workspace, click the right mouse button on the Rosemount 2460 icon and choose **Properties**.
3. Select the **Tank Database** tab.
4. For the **Sakura V1** device, press the **Advanced** button to open the **Sakura Configuration** window:

2460 Tank	Source	Field Port	2410 Device Address	2410 Tank Pos	Level Device Address	Temp Device Address	Number of Temp Elements	VP	MP	LP	FWL	Dens	UIIn1	UIIn2	UIIn3	UIIn4	UIIn5	Relays	Adv.
1	2410	1	101	1	41	101	16	VP	-	-	-	-	UIIn 1	-	-	-	-	-	-
2	2410	1	101	2	42		0	-	-	-	-	-	-	-	-	-	-	-	-
3	2410	1	101	3	43		0	-	-	-	-	-	-	-	-	-	-	-	-
4	2410	1	110	1	1	110	16	-	-	-	-	-	-	-	-	-	-	-	-
5	2410	1	110	2	2		0	-	-	-	-	-	-	-	-	-	-	-	-
6	Sakura V1	3			26		0	-	-	-	-	-	-	-	-	-	-	-	-
7	(none)																		
8	(none)																		
9	(none)																		
10	(none)																		
11	(none)																		

5. Set the configuration parameters as desired.
6. Press **OK** to save the current configuration and close the configuration window.

#### Related information

[Fast polling](#)

### Sakura V1 configuration window

The **Sakura V1 Configuration** window lets you configure advanced options.

Figure K-1: Sakura V1 Configuration Window

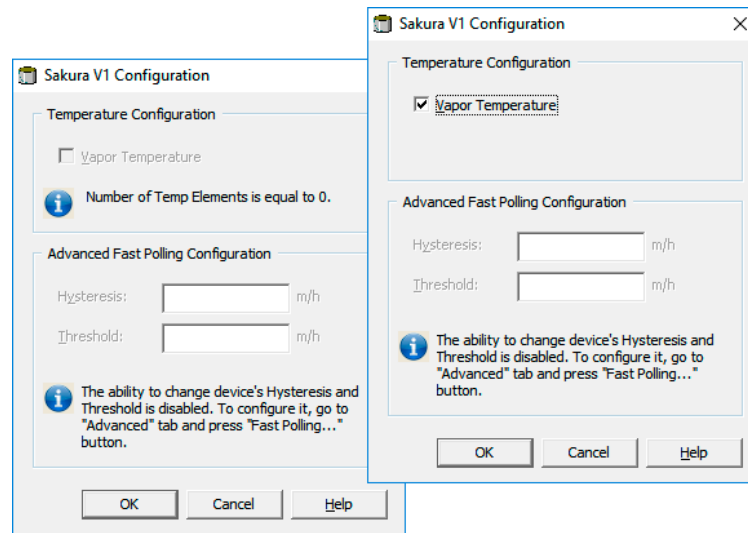

Table K-2: Advanced Sakura V1 Configuration Options

Option	Description
Vapor Temperature	Lets the Sakura V1 device use Vapor Temperature input. Note that <b>Number of Temp Elements</b> in the system hub's tank database must be set to other than zero for this option to be available.
Advanced Fast Polling	This option is valid for all the supported Sakura devices.



# L NRF590 configuration

## L.1 Tank Database configuration for NRF590/4590 devices

This section describes how to configure the Rosemount 2460 System Hub's tank database for NRF590/4590 devices.

The NRF590/4590<sup>(15)</sup> option can be used for devices supporting Tank Side Monitoring (TSM) Modbus communication.

### Prerequisites

Ensure that the field port is equipped with the appropriate modem.

Verify that the system hub's Holding Register #39402 **EmulProt-ModbusTsmMode** is properly configured. This register specifies the order in which data sent by the NRF590 is interpreted by the Rosemount 2460.

### Procedure

1. In TankMaster WinSetup right-click the Rosemount 2460 System Hub that the device is connected to and choose **Properties**.
2. Select the **Tank Database** tab.

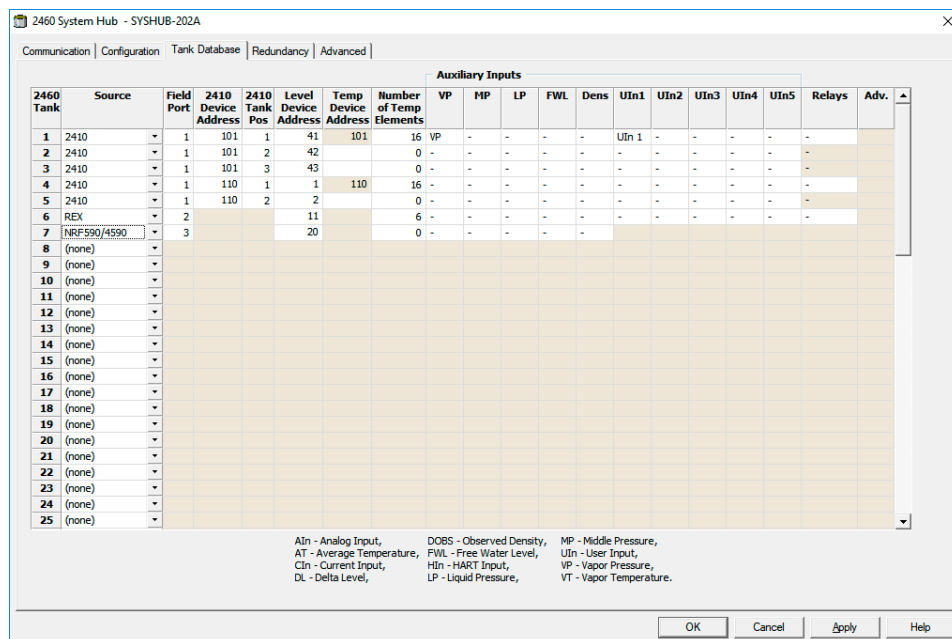

3. Find a free tank position (2460 Tank 1, 2, 3...) for the device to be configured.

<sup>(15)</sup> Will be referred to as NRF590.

- In the **Source** drop-down list select **NRF590**.

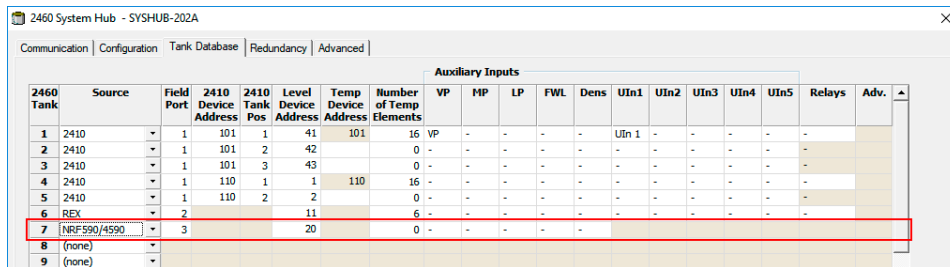

- Ensure that the proper field port is selected.  
In the standard configuration there are six field bus ports available for the Rosemount 2460 System Hub.
- Enter the communication address into the **Level Device Address** field.
- The **Temp Device Address** field can not be edited. The address is automatically set to the address of the level device.
- Select **Auxiliary Inputs** applicable for the device.  
Vapor Pressure (VP), Liquid Pressure (LP), Free Water Level (FWL), and Observed Density (Dobs) can be configured for NRF590 devices.

#### Related information

[Modem cards](#)

[Connecting to a Rosemount 2460 System Hub](#)

[Tank Database entry fields for NRF590/4590 devices](#)

## L.1.1

### Tank Database entry fields for NRF590/4590 devices

**Table L-1: Summary of Tank Database Entry Fields**

Entry field	Description
Source	NRF 590/4590 <sup>(1)</sup>
Field Port	The field bus port that the selected device is connected to. Up to six field ports may be used.
Level Device Address	Level device address. Each field device has its own unique address in the range 1-247.
Temp Device Address	Temperature is automatically set to the same address as the level device.
Number of Temp Elements	“0” in case only average temperature is required. Otherwise the total number of connected temperature elements. In case you don’t need to monitor values for individual temperature elements you should set this parameter to “0” in order to avoid unnecessary load on the field bus.
Auxiliary Inputs	<ul style="list-style-type: none"> <li>Vapor Pressure (VP)</li> <li>Middle Pressure (MP)</li> <li>Liquid Pressure (LP)</li> <li>Free Water Level (FWL)</li> <li>Observed Density (DOBS)</li> </ul>

<sup>(1)</sup> NRF option is supported for Rosemount 2460 firmware version 1.E0 and higher.





For more information: [Emerson.com/global](https://emerson.com/global)

©2024 Emerson. All rights reserved.

Emerson Terms and Conditions of Sale are available upon request. The Emerson logo is a trademark and service mark of Emerson Electric Co. Rosemount is a mark of one of the Emerson family of companies. All other marks are the property of their respective owners.

**ROSEMOUNT™**

