

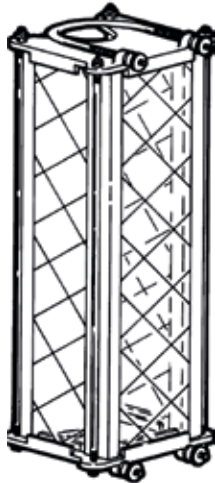

**PENBERTHY WIRE GLASS/PLASTIC PROTECTOR**  
 INSTALLATION, OPERATION AND MAINTENANCE INSTRUCTIONS

Before installation these instructions must be read fully and understood



**Product warranty**

Emerson warrants its Penberthy products as designed and manufactured to be free of defects in the material and workmanship for a period of one year after the date of installation or eighteen months after the date of manufacture, whichever is earliest. Emerson will, at its option, replace or repair any products which fail during the warranty period due to defective material or workmanship.

Prior to submitting any claim for warranty service, the owner must submit proof of purchase to Emerson and obtain written authorization to return the product. Thereafter, the product shall be returned to Emerson, with freight paid.

This warranty shall not apply if the product has been disassembled, tampered with, repaired or otherwise altered outside of Emerson’s factory, or if it has been subject to misuse, neglect or accident.

The responsibility of Emerson hereunder is limited to repairing or replacing the product at its expense. Emerson shall not be liable for loss, damage or expenses related directly or indirectly to the installation or use of its products or from any other cause or for consequential damages. It is expressly understood that Emerson is not responsible for damage or injury caused to other products, buildings, personnel or property, by reason of the installation or use of its products.

*This is Emerson’s sole warranty and in lieu of all other warranties, expressed or implied which are hereby excluded, including in particular all warranties of merchantability or fitness for a particular purpose.*

This document and the warranty contained herein may not be modified and no other warranty, expressed or implied, shall be made by or on behalf of Emerson unless made in writing and signed by the company’s general manager or director of engineering.

**TABLE OF CONTENTS**

Product warranty ..... 1

1. About the manual ..... 2

2. Introduction ..... 2

    2.1 Features and specifications ..... 2

    2.2 Application data ..... 2

3. Inspection ..... 2

    3.1 Receiving inspection ..... 2

    3.2 User’s rating inspection ..... 2

4. Installation ..... 2-3

    4.1 Assembly of wire glass/plastic protector ..... 2

    4.2 Assembly of wire glass/plastic protector to gagecock assembly ..... 3

5. Operation ..... 3

    5.1 Pre-operational check ..... 3

    5.2 Operating ..... 3

6. Maintenance ..... 3

    6.1 Preventative maintenance ..... 3

    6.2 Maintenance procedures ..... 3

7. Removal - disassembly - reassembly ..... 4

    7.1 Disassembly ..... 4

    7.2 Reassembly ..... 4

8. Disposal at end of useful life ..... 4

9. Telephone assistance ..... 4

10. Exploded parts diagram ..... 5

**Figures**

Figure 1 Assembly ..... 3

Figure 2 Assembly ..... 3

Figure 3 Exploded parts diagram ..... 5

# PENBERTHY WIRE GLASS/PLASTIC PROTECTOR

## INSTALLATION, OPERATION AND MAINTENANCE INSTRUCTIONS

---

### 1 ABOUT THE MANUAL

---

This manual has been prepared as an aid and guide for personnel involved in installation or maintenance. All instructions must be read and understood thoroughly before attempting any installation, operation or maintenance.

#### IMPORTANT

*Emerson does not have control over the manner in which its wire glass/plastic protector is handled, installed or used and Emerson cannot and does not warrant or guarantee that the wire glass/plastic protector is suitable for or compatible with the user's specific application.*

#### CAUTION

*Failure to follow any instruction could possibly result in a failure of the wire glass/plastic protector to provide the proper protection for which it was designed, thereby causing property damage or physical injury.*

### 2 INTRODUCTION

---

#### 2.1 Features and specifications

Penberthy wire glass/plastic protectors are designed to be mounted easily to tubular gagecock assemblies to help protect against breakage of the tubular glass from outside sources and also to help minimize the possibility of injury or property damage should the tubular gage glass break.

#### 2.2 Application data

**Note:** for specific application data, the user should consult the product proposal for the specific wire glass/plastic protector or should request the supply of the applicable technical data sheet.

#### WARNING

*Under no circumstances should the application data be exceeded. Exceeding application data may cause severe physical injury or property damage.*

### 3 INSPECTION AND PERFORMANCE CONFIRMATION

---

#### 3.1 Receiving inspection

On receipt of a wire glass/plastic protector, check all components carefully for damage incurred in shipping. If damage is evident or suspected, do not attempt installation. Notify the carrier immediately and request a damage inspection.

#### 3.2 User's rating inspection

The user should confirm that:

1. The length of the wire glass/plastic protector conforms to the length as described on the user's purchase order.

2. The operating conditions described in the purchase order agree with the actual operating conditions at the installation site.
3. The actual operating conditions at the installation site are within the application data shown on the relevant technical data sheet or product proposal referred to above.
4. The materials of construction of the wire glass/plastic protector are compatible with the surrounding atmosphere in the specific application.

#### SAFETY INSTRUCTIONS

*If the length or performance data of the wire glass/plastic protector as received does not conform with any of the criteria above, do not proceed with installation. Contact an authorized Penberthy distributor for direction.*

### 4 INSTALLATION

---

Installation should only be undertaken by qualified, experienced personnel who are familiar with this equipment and have read and understood all the instructions in this manual. The user should refer to the product proposal to obtain dimensional information for the specific size wire glass/plastic protector.

#### 4.1 Assembly of wire glass/plastic protector

1. Secure a workbench with sufficient width and length to layout parts.
2. Refer to exploded view in Figure 3 for general location of parts.
3. Place all glass edge channel protectors on pieces of wire glass/plastic, and set side by side on the work bench.
4. Thread a nut onto one end of each rod until the top of the nut is flush with the end of the rod.
5. Place upper and lower brackets, front side down to work bench, spaced at the approximate length of the front glass piece.
6. Insert each end of the front glass/plastic piece into the corresponding slots of the upper and lower brackets.
7. Insert two (2) rods through the front holes of the upper and lower brackets and thread a nut onto each rod end finger tight.
8. Insert both side glass/plastic pieces into the corresponding slots of the upper and lower brackets, making certain that the glass/plastic edge protectors remain in place.
9. Insert the remaining two (2) rods through the back holes of the upper and lower brackets and thread a nut onto each rod end finger tight.
10. Tighten all nuts wrench tight making certain that all glass/plastic pieces fit properly into the slots of the upper and lower brackets.

# PENBERTHY WIRE GLASS/PLASTIC PROTECTOR

## INSTALLATION, OPERATION AND MAINTENANCE INSTRUCTIONS

### 4.2 Assembly of wire glass/plastic protector to gagecock assembly

1. Hold wire glass/plastic protector up to gagecock assembly with the front of the protector facing away from the vessel.
2. Place a U-bolt around the glass protector nut of the upper gagecock and through the corresponding holes in the upper bracket of the wire glass/plastic protector and thread on thumb nuts finger tight. Repeat this procedure on the lower end of the gagecock. Refer to Figures 1 and 2.

**Note:** if gagecocks are not furnished with wire glass/plastic protector nuts, the U-bolts should be placed around the body of the gagecocks.

### 5 OPERATION

#### 5.1 Pre-operational check

1. Ensure that all installation procedures have been completed.
2. Ensure that the wire glass/plastic protector gives the proper protection over the entire length of the tubular glass of the gagecock assembly.

#### 5.2 Operating

Gages should be brought into service slowly. The glass used in Penberthy gages is tempered and can stand minimal thermal shock and mechanical stress.

To avoid excessive thermal shock and mechanical stress on the glass, the connecting gagecocks should be opened slightly, and the gage temperature and pressure allowed to equalize slowly with the vessel.

If the gagecocks are equipped with ball checks, the gagecocks must be opened all the way after pressure and temperature have equalized to permit operation of the automatic ball check in the event of gage failure.

### 6 MAINTENANCE

Maintenance should only be undertaken by qualified, experienced personnel who are familiar with this equipment and have read and understood all the instructions in this manual.

#### CAUTION

*Do not proceed with any maintenance unless the gagecock assembly has been relieved of all pressure or vacuum, has been allowed to reach ambient temperature and has been drained or purged of all fluids. Failure to follow these instructions may result in physical injury or property damage.*

#### 6.1 Preventative maintenance

The user must determine an appropriate maintenance schedule necessary for his or her specific application upon evaluation of their own operating experience. Realistic maintenance schedules can only be determined with full knowledge of the services and application situations involved.

#### 6.2 Maintenance procedures

Clean glass/plastic with a commercial glass cleaner and a soft grit free cloth. DO NOT use a wire brush, metal scraper or any other device which could scratch the glass/plastic.

FIGURE 1

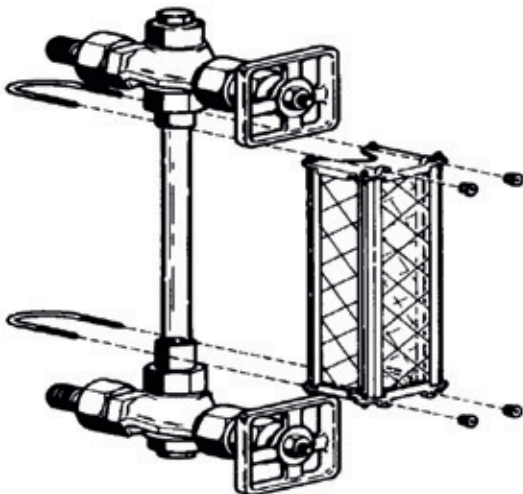
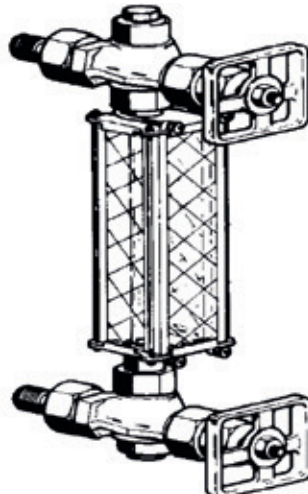

FIGURE 2



# PENBERTHY WIRE GLASS/PLASTIC PROTECTOR

## INSTALLATION, OPERATION AND MAINTENANCE INSTRUCTIONS

---

### 7 REMOVAL - DISASSEMBLY - REASSEMBLY

---

#### CAUTION

*Do not proceed with the removal of a wire glass/plastic protector unless the gagecock assembly has been relieved of all pressure or vacuum, has been allowed to reach ambient temperature and has been drained or purged of all fluids. Failure to follow these instructions may result in physical injury or property damage.*

#### 7.1 Disassembly

- a. While holding the wire glass/plastic protector firmly, loosen and remove the thumb nuts of the upper and lower brackets.
- b. While still holding the wire glass/plastic protector firmly, slip U-bolts out of the upper and lower brackets and remove wire glass/plastic protector from gagecock assembly.

#### 7.2 Reassembly

Refer to Section 4.2 for assembly of wire glass/plastic protector to gagecock assembly.

**Note:** refer to Section 5 Operation when returning to service.

### 8 DISPOSAL AT END OF USEFUL LIFE

---

Penberthy wire glass/plastic protectors are used in a variety of fluid applications. By following the appropriate federal and industry regulations, the user must determine the extent of preparation and treatment the wire glass/plastic protector must incur before its disposal. A Material Safety Data Sheet (MSDS) may be required before disposal services accept certain components.

Metal, glass and polymers should be recycled whenever possible. Refer to order and applicable technical data sheets for materials of construction.

### 9 TELEPHONE ASSISTANCE

---

If you are having difficulty with your wire glass/plastic protector, contact your local Penberthy distributor. You may also contact the factory direct at (956) 430-2500 and ask for an applications engineer. So that we may assist you more effectively, please have as much of the following information available as possible when you call:

- Model #
- Name of the company from whom you purchased the wire glass/plastic protector
- Invoice # and date
- Process conditions (pressure, flow rates, tank shape, etc)
- A brief description of the problem
- Trouble shooting procedures that failed

If attempts to solve your problem fail, you may request to return your wire glass/plastic protector to the factory for intensive testing. You must obtain a Return Authorization (R.A.) number from Emerson before returning anything. Failure to do so will result in the unit being returned to you without being tested, freight collect. To obtain an R.A. number, the following information (in addition to that above) is needed:

- Reason for return
- Person to contact at your company
- 'Ship-to' address

There is a minimum charge for evaluation of non-warranty units. You will be contacted before any repairs are initiated should the cost exceed the minimum charge. If you return a unit under warranty, but it is not defective, the minimum charge will apply.

# PENBERTHY WIRE GLASS/PLASTIC PROTECTOR

## INSTALLATION, OPERATION AND MAINTENANCE INSTRUCTIONS

### 10 EXPLODED PARTS DIAGRAM

FIGURE 3

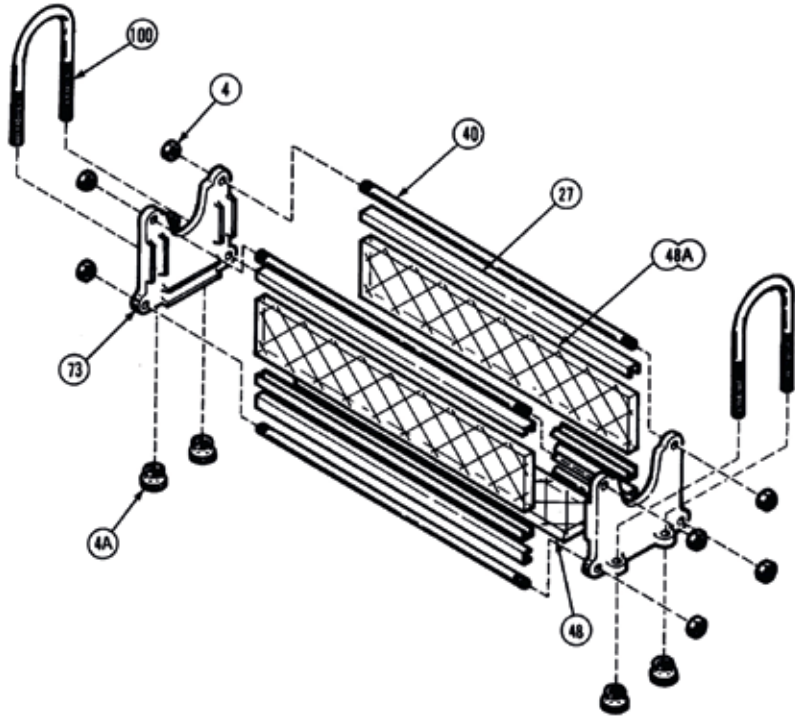

### PARTS LIST

Item	Description
4	Nut
4A	Nut
27	Channel
40	Rod
48	Glass
48A	Glass
73	Bracket
100	Screw

Neither Emerson, Emerson Automation Solutions, nor any of their affiliated entities assumes responsibility for the selection, use or maintenance of any product. Responsibility for proper selection, use, and maintenance of any product remains solely with the purchaser and end user.

Penberthy is a mark owned by one of the companies in the Emerson Automation Solutions business unit of Emerson Electric Co. Emerson Automation Solutions, Emerson and the Emerson logo are trademarks and service marks of Emerson Electric Co. All other marks are the property of their respective owners.

The contents of this publication are presented for informational purposes only, and while every effort has been made to ensure their accuracy, they are not to be construed as warranties or guarantees, express or implied, regarding the products or services described herein or their use or applicability. All sales are governed by our terms and conditions, which are available upon request. We reserve the right to modify or improve the designs or specifications of such products at any time without notice.

Emerson.com/FinalControl