

Packing Selection Guidelines for Fisher™ Sliding-Stem Valves



General Application

This bulletin provides information to help you select the proper Fisher packing system, whether it is live-loaded or non-live-loaded. Live-loaded features the Fisher enhanced ENVIRO-SEAL™ packing systems.

Fisher enhanced ENVIRO-SEAL Packing Systems

Fisher enhanced ENVIRO-SEAL live-loaded packing systems consist of ENVIRO-SEAL, ENVIRO-SEAL HS (HIGH-SEAL) and ENVIRO-SEAL IS (ISO-SEAL) and offer exceptional stem sealing capabilities. These systems easily install in your existing valves or can be purchased with new valves. The enhanced ENVIRO-SEAL packing systems help seal your process to conserve valuable process fluid and protect the environment against the emission of hazardous or polluting fluids. The long life and reliability of these systems also reduce your maintenance costs and downtime.

For process control applications requiring compliance with environmental protection regulations, the unique enhanced ENVIRO-SEAL packing systems and, for hazardous service, the ENVIRO-SEAL bellows seal systems are offered. These packing systems keep fugitive emission concentrations below the 100 ppm (parts per million) requirement set by the United States Environmental Protection Agency (EPA) and may offer certified performance to ISO-15848-1 at a tightness class of AM (≤ 50 ppm) and BH ($\leq 3.14 \times 10^{-7}$ mg*s⁻¹*mm⁻¹ stem/shaft diameter).

The enhanced ENVIRO-SEAL packing systems feature live-loading and unique packing-ring arrangements for consistent, long-term sealing performance. The enhanced ENVIRO-SEAL packing systems offer PTFE, Duplex, H2 Duplex and Graphite ULF, while the enhanced ENVIRO-SEAL HS (HIGH-SEAL) provides a higher pressure/temperature Graphite ULF. The enhanced ENVIRO-SEAL IS (ISO-SEAL) has both PTFE and Graphite options for ISO-15848-1 applications.

Figure 1. Fisher easy-e™ Valve Bonnet with enhanced ENVIRO-SEAL™ Packing

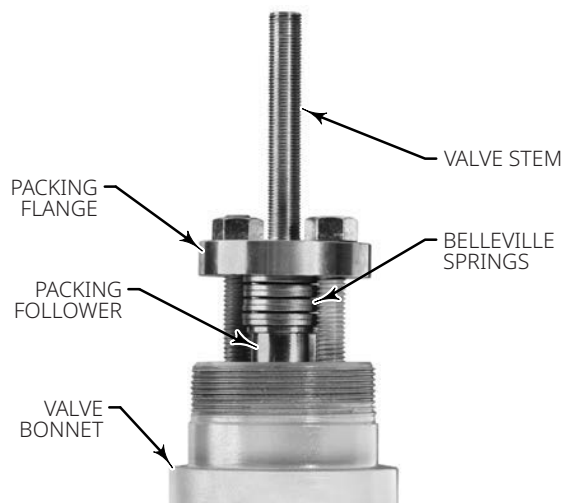

W5814-1

Features

- **Compliance with the US Clean Air Act –** The excellent stem sealing of the enhanced ENVIRO-SEAL packing systems control emissions to below the EPA minimum of 100 ppm and may offer certified ISO-15848-1 performance.
- **Easy Installation in Existing Valves –** All parts needed to install the packing systems in existing valves are available in a convenient kit.
- **Adaptable to Many Applications –** The enhanced ENVIRO-SEAL packing systems fit a wide range of Fisher Sliding-Stem valves.
- **Improved Service Life –** The enhanced ENVIRO-SEAL packing systems offer long service life with minimal maintenance. The live-loading provides a constant load over the life of the packing material. This greatly reduces or, in many applications, helps to eliminate your need for packing box adjustment and maintenance. The installed packing system provides excellent sealing, guiding and transmission of loading force.

Enhanced ENVIRO-SEAL Specifications

Construction Materials	
<p>PTFE Packing Systems: Packing Ring and Lower Wiper: PTFE V-ring⁽¹⁾ Male and Female Adaptor Rings: Carbon-filled PTFE V-ring Optional Male and Female Adaptor Rings: Glass-filled PTFE V-ring</p> <p>Duplex Packing Systems: Packing Rings: PTFE and Graphite</p> <p>Graphite ULF Packing Systems: Packing Rings: Graphite Bushings: Carbon-Graphite</p>	<p>Anti-Extrusion Washer: Filled PTFE (not required for graphite packing)</p> <p>Lantern Ring: S31600 (316 SST) (not required for graphite packing)</p> <p>Packing Box Flange: S31600</p> <p>Spring: N07718</p> <p>Packing Follower: S31600 lined with carbon-filled PTFE</p> <p>Packing Box Studs: Strain-hardened 316 SST</p> <p>Packing Box Nuts: 316 SST (SA194 Grade 8M)</p>
<p>1. In vacuum service, it is not necessary to reverse the ENVIRO-SEAL PTFE packing rings.</p>	

Enhanced ENVIRO-SEAL HS (HIGH-SEAL) Specifications

Construction Materials	
<p>Packing Rings: Carbon/graphite composition, graphite and zinc</p> <p>Packing Box Bushing: Graphite</p>	<p>Springs: ■ S17700 (17-7 SST), ■ N07718</p> <p>Packing Box Flange, Studs and Nuts: ■ S31600 (316 SST) ■ Other materials available upon request</p>

Enhanced ENVIRO-SEAL IS (ISO-SEAL) Specifications

Construction Materials	
<p>PTFE Packing Systems: Packing Rings: Braided PTFE Ring Anti-Extrusion Rings: High strength polymer Packing Box Rings: S31600 (316 SST)</p> <p>Packing Box Studs: Strain-hardened 316 SST</p> <p>Spring Pack Components: O-ring: Nitrile. The O-ring serves as an assembly convenience to hold the springs in position on the packing follower Packing Follower: S31600 with carbon-filled PTFE liner</p>	<p>Packing Box Studs: 316 SST (SA194 Grade 8M)</p> <p>Graphite Packing System: Packing Rings: Graphite Anti-Extrusion Rings: Carbon Packing Box Rings: S31600 (316 SST)</p> <p>Packing Flange: ■ S31600 (316 SST) ■ Other materials available upon request</p>

Live-Loaded Packing

Table 1. Fisher Live-Loaded Packing Selection Guidelines for Sliding-Stem Valves

Live-Loaded Packing ⁽¹⁾		Seal Performance Index	Service Life Index	Packing Friction ⁽²⁾	Fire-Tested Per API 589	ENVIRO-SEAL Bellows Compatible
Enhanced ENVIRO-SEAL Packing Systems	ENVIRO-SEAL PTFE	Best	Very Long	Low		●
	ENVIRO-SEAL Duplex	Best	Very Long	Low	●	●
	ENVIRO-SEAL H2 Duplex	Best	Very Long	Medium	●	●
	ENVIRO-SEAL Graphite ULF	Best	Very Long	Medium	●	●
	ENVIRO-SEAL HS (HIGH-SEAL) Graphite ULF	Best	Very Long	Medium	●	
	ENVIRO-SEAL IS (ISO-SEAL) PTFE	Best	Long	Medium		
	ENVIRO-SEAL IS (ISO-SEAL) Graphite	Best	Long	High		
HIGH-SEAL Graphite		Better	Very Long	Very High	●	
KALREZ with Vespel CR-1600 (KSVP 500)		Best	Long	Medium	●	●
<p>● Indicates availability</p> <p>1. Table 1 packing options do not apply to Baumann Sliding-Stem valves. See appropriate Baumann product bulletins for packing options.</p> <p>2. See Fisher Catalog 14 for actual friction values.</p>						

Live-loaded packing systems are utilized for two categories or purposes: extended service life and protection against fugitive emissions. The most common standards encountered for fugitive emissions are EPA Method 21 per ANSI/FCI 91-2 and ISO 15848-1.

Depending on category requirements, different pressure/temperature guidelines have been established for the packing systems. In addition, a given packing design has certain characteristics concerning seal performance, service life and friction. The pressure and temperature guidelines and the relative comparison of these characteristics are defined in Table 1, Figures 2 and 12.

Extension bonnets can be used to extend temperature capability. Reference applicable product bulletin for bonnet selection options/guidelines.

Service Life

Even for services not requiring fugitive emission control, service life can be extended by using enhanced ENVIRO-SEAL and enhanced ENVIRO-SEAL HS (HIGH-SEAL) packing systems. As service pressures and temperatures increase, the enhanced ENVIRO-SEAL packing systems provide a significant step change in performance, compared to the traditional single PTFE V-ring or braided graphite filament arrangements.

Figure 2. Applications Guidelines Chart for Extended Service Life

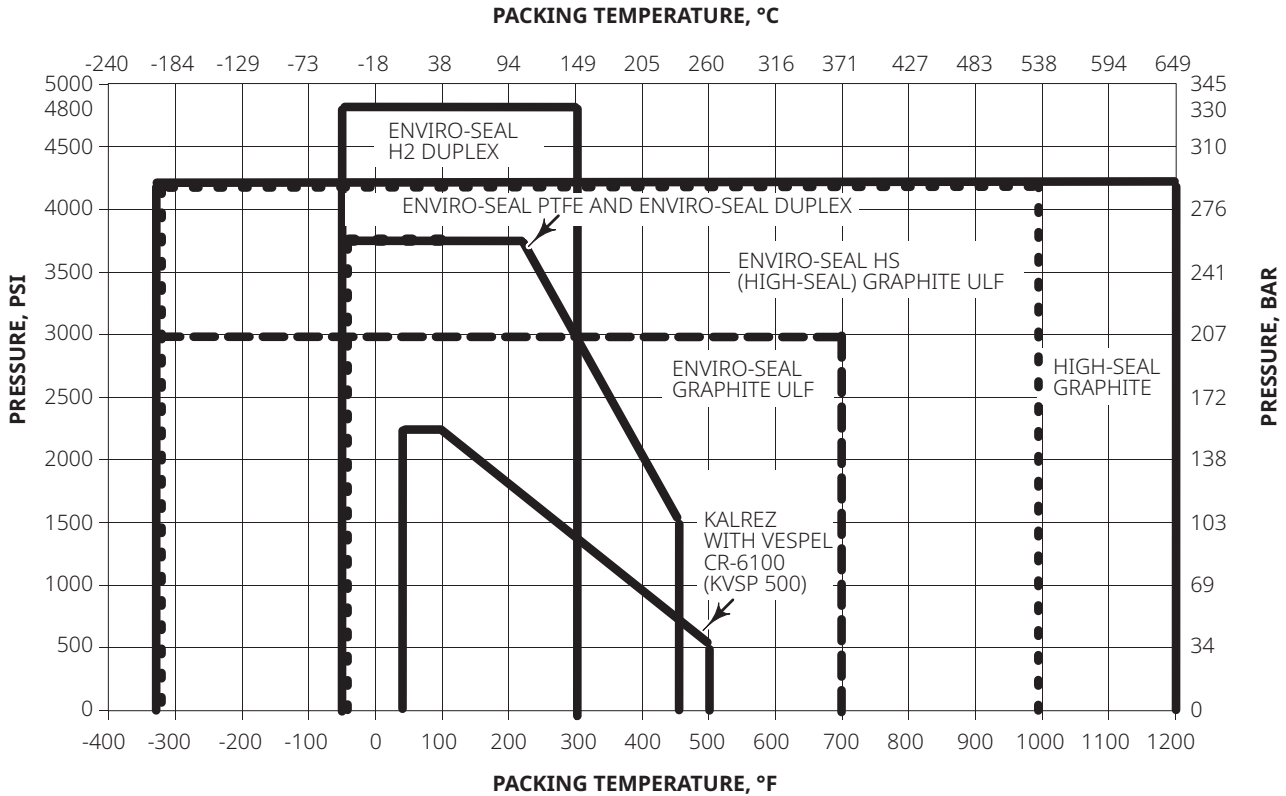

NOTE: MATERIAL AND COMPONENT SPECIFICATIONS ARE THE SAME FOR ENHANCED ENVIRO-SEAL PACKING SYSTEMS AND ENVIRO-SEAL PACKING SYSTEMS FOR EXTENDED SERVICE LIFE.

Enhanced ENVIRO-SEAL PTFE Packing

The enhanced ENVIRO-SEAL PTFE packing system is designed to operate at high stress and has excellent sealing capability. This gives the enhanced ENVIRO-SEAL PTFE packing system the ability to compensate for stem or packing bore imperfections. The high packing stress design approach also results in an increase in stem friction. Typically, this slight increase in stem friction does not cause problems, such as hysteresis, for actuator sizing or process control. It is good practice, however, to always verify actuator sizing whenever you select a different packing material. Carbon-filled PTFE or glass-filled PTFE adaptor rings can be selected for process compatibility.

Figure 3. Enhanced ENVIRO-SEAL PTFE Packing

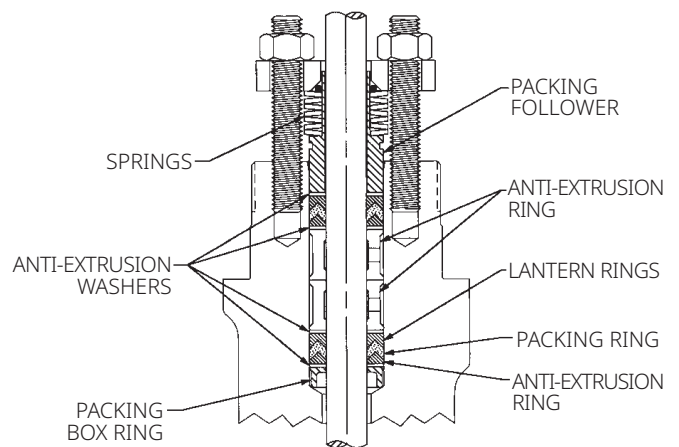

A6163-1

Enhanced ENVIRO-SEAL Duplex Packing

The enhanced ENVIRO-SEAL Duplex packing systems were developed, utilizing the benefits of both PTFE and graphite components. These special packing systems provide the capability of graphite packing along with low friction advantages of PTFE packing. Enhanced ENVIRO-SEAL Duplex packing systems provide a low friction, low emission, fire-tested solution, have been tested in accordance with API Standard 589, Fire Test Evaluation of Valve Stem Packing.

Figure 4. Enhanced ENVIRO-SEAL Duplex Packing

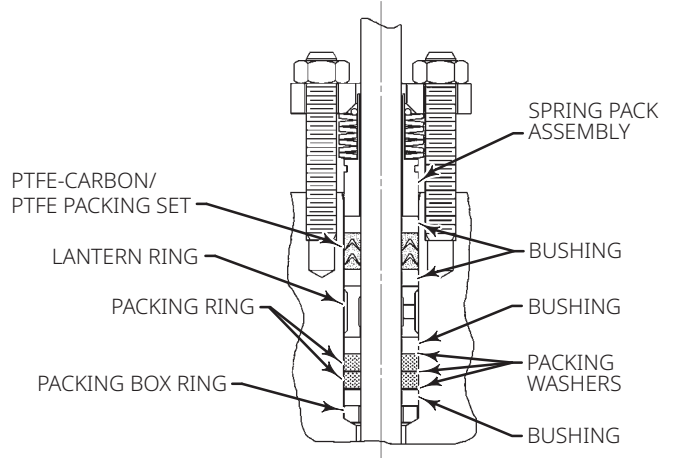

24B9310
 A6844

Enhanced ENVIRO-SEAL H2 (Hydrogen) Duplex Packing

The enhanced ENVIRO-SEAL H2 Duplex packing is designed for high pressure applications that require low emissions performance. This packing set uses a PTFE packing set with carbon-reinforced packing adaptors enveloped between both anti-extrusion washers and close-fit graphite bushing guides to provide three modes of anti-extrusion protection. It is suitable for environmental service up to 138 bar / 2000 psig and 149°C / 300°F.

Figure 5. Enhanced ENVIRO-SEAL H2 Duplex Packing

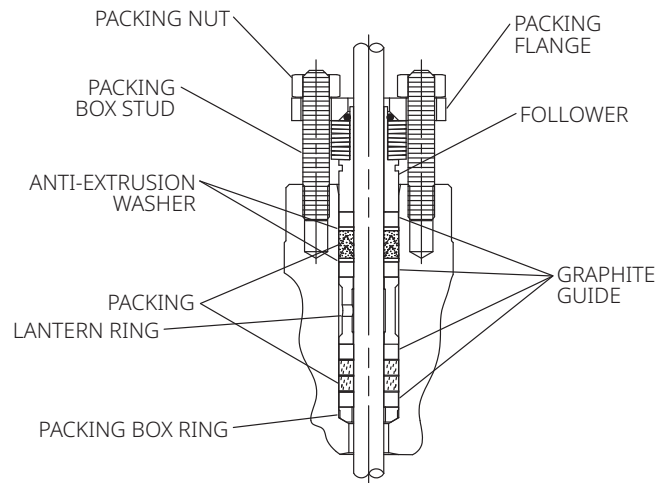

NOTE: LEAK-OFF TAPPING AND PIPE PLUG ARE OPTIONAL.

Enhanced ENVIRO-SEAL Graphite ULF

The enhanced ENVIRO-SEAL Graphite ULF packing is designed primarily for applications at elevated temperatures in excess of 232°C / 450°F. For best performance, the service temperature should be a least 149°C / 300°F. At temperatures below 149°C / 300°F, packing wear may be accelerated compared to higher temperatures.

Compared to PTFE packing systems, graphite packing systems operate at higher stress levels and have higher friction values for a given level of sealing. To combat this, most graphite systems incorporate a small amount of PTFE which acts primarily as a lubricant.

The ULF packing system, incorporates thin PTFE layers inside the packing rings as well as thin PTFE washers placed on each side of the packing rings. This strategic placement of PTFE material minimizes control problems (such as slip-stick action), reduces friction, promotes sealing and extends the cycle life of the packing set. (With slip-stick action, packing friction prevents the valve stem from moving until stem force increases enough to make the stem move suddenly.) While the PTFE components of the ULF packing set are critical to the overall performance of the packing set, they make up a very small percentage of the ULF packing set and do not require additional follower travel. The ULF packing system has remarkably low stem friction at elevated temperatures, compared to other graphite packing systems. The enhanced ENVIRO-SEAL Graphite ULF packing systems have been successfully tested in accordance with API Standard 589, Fire Test Evaluation of Valve Stem Packing.

Figure 6. Enhanced ENVIRO-SEAL Graphite ULF Packing

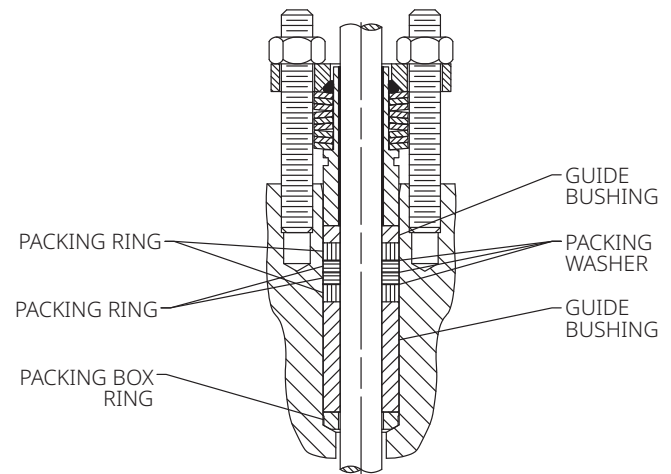

39B4612-A

Enhanced ENVIRO-SEAL HS (HIGH-SEAL) Graphite ULF

The enhanced ENVIRO-SEAL HS (HIGH-SEAL) Graphite ULF packing system is identical to the enhanced ENVIRO-SEAL Graphite ULF packing system below the packing follower. The primary advantage of the enhanced ENVIRO-SEAL HS (HIGH-SEAL) packing system is the use of large diameter Belleville springs. These heavy duty springs offer additional follower travel and can be calibrated with a load scale. The load scale provides a visual indication of packing load and packing wear, making it easier for you to determine when additional torquing might be required.

Figure 7. Enhanced ENVIRO-SEAL HS (HIGH-SEAL) Graphite ULF Packing

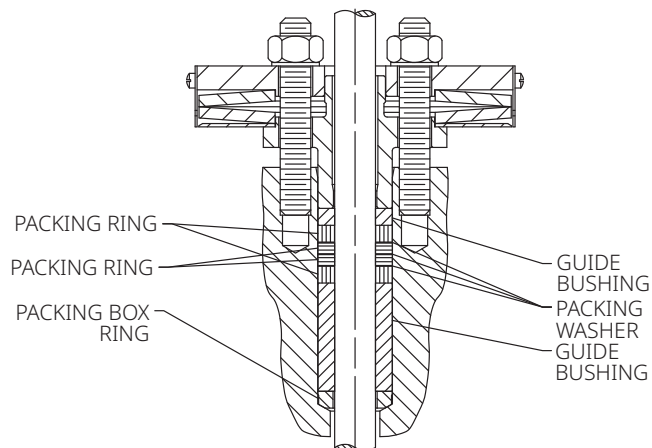

39B4153-A

Enhanced ENVIRO-SEAL IS (ISO-SEAL) PTFE

The enhanced ENVIRO-SEAL IS (ISO-SEAL) PTFE packing uses unique live-loaded Belleville spring combinations to provide low emission, tight sealing for pressure classes up to CL2500. The packing system contains braided PTFE-impregnated yarn rings and wire-reinforced anti-extrusion rings for use up to 250°C / 482°F at the packing box and is intended for ISO 15848-1 applications. This system is BAM approved for gaseous oxygen service up to 15 bar and 60°C / 140°F.

Figure 8. Enhanced ENVIRO-SEAL IS (ISO-SEAL) Packing

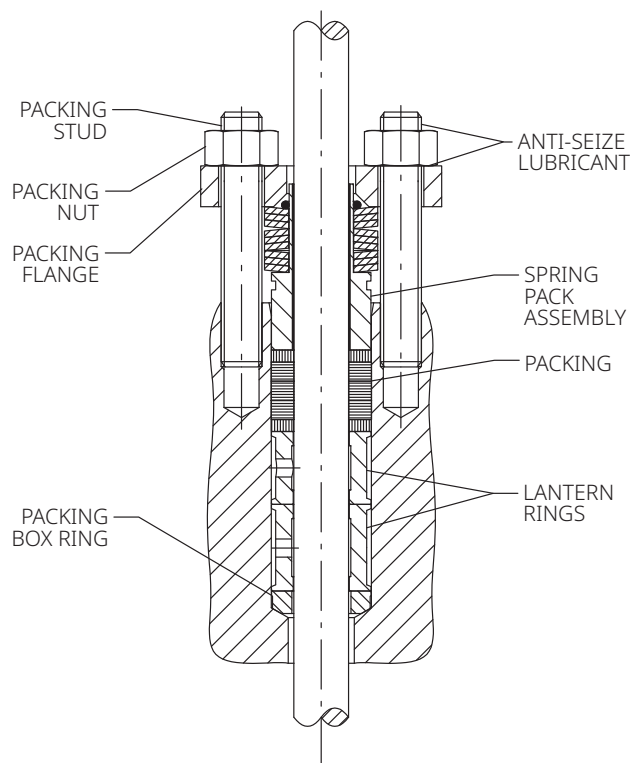

GF07999-B

Enhanced ENVIRO-SEAL IS (ISO-SEAL) Graphite

The enhanced ENVIRO-SEAL IS (ISO-SEAL) Graphite packing uses unique live-loaded Belleville spring combinations to provide low emission, tight sealing for pressure classes up to CL2500. The packing system contains expanded graphite rings and wire-reinforced anti-extrusion rings for use up to 450°C / 842°F at the packing box and is intended for ISO 15848-1 applications. This system is BAM approved for 50 bar / 725 psig up to 100°C / 212°F and for 30 bar / 435 psig up to 225°C / 437°F for both gaseous oxygen and liquid oxygen service.

Fisher easy-e Trim Cartridge with enhanced ENVIRO-SEAL Packing Systems

The Fisher easy-e Trim Cartridge is a complete control valve repair solution that incorporates a full trim recommended spare parts list (RSPPL) replacement plus a new bonnet in a single, factory assembled repair cartridge. Trim Cartridge has the same fit and function of traditional easy-e trim, making it backwards compatible into existing easy-e constructions. In addition to being pre-assembled, each Trim Cartridge is tested to ensure CL V shutoff capability and has a live-loaded enhanced ENVIRO-SEAL packing system, allowing for a simplified installation that reduces trim repair time and complexity.

Trim Cartridge contains enhanced ENVIRO-SEAL PTFE packing as the standard packing offering. Other available packing options are enhanced ENVIRO-SEAL Graphite ULF and enhanced ENVIRO-SEAL Duplex. PEEK high temperature anti-extrusion rings are also available.

For more information on Trim Cartridge see the Fisher ET, EAT and ETR Sliding-Stem Control Valves bulletin ([D100022X012](#)) and the Fisher EZ Sliding-Stem Control Valve bulletin ([D100025X012](#)).

Figure 9. Fisher easy-e Trim Cartridge with enhanced ENVIRO-SEAL Packing

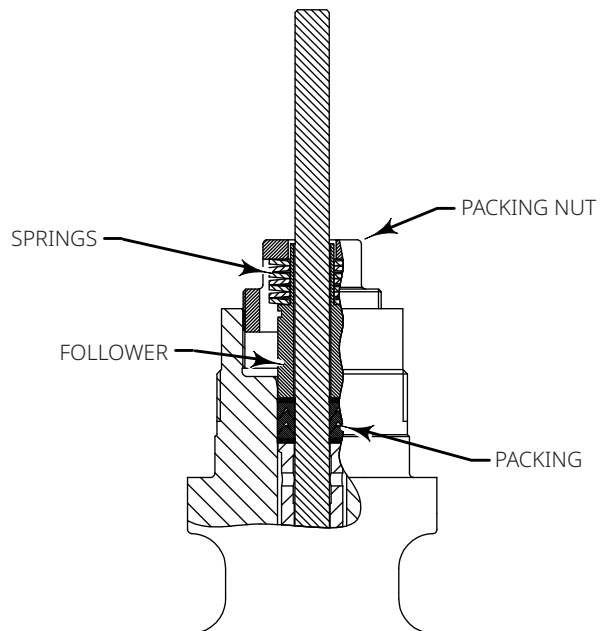
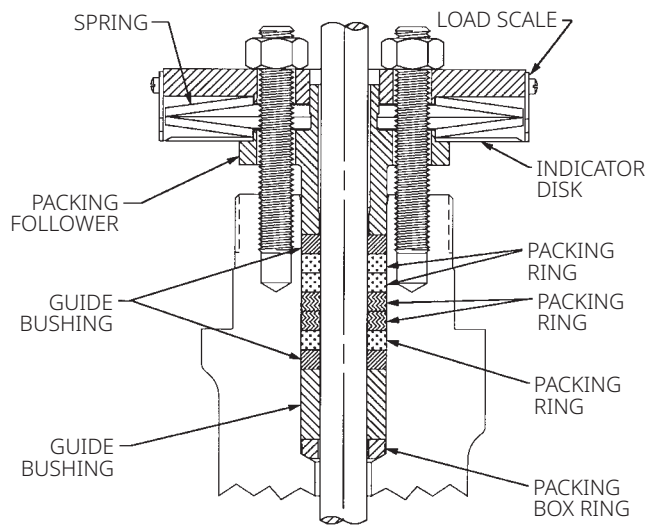
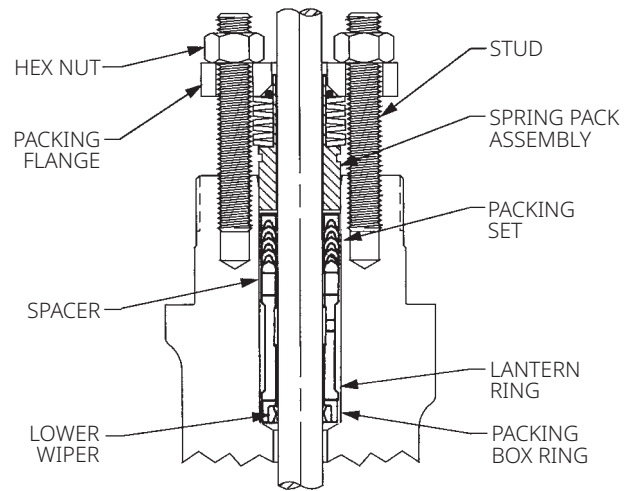

Figure 10. Fisher HIGH-SEAL Graphite Packing



A6167-1

Figure 11. KALREZ with Vespel CR-6100 Packing



A6843

NOTE: LEAK-OFF TAPPING AND PIPE PLUG ARE OPTIONAL.

HIGH-SEAL Graphite

The HIGH-SEAL Graphite packing system uses graphite composite rings without PTFE for higher temperature applications in addition to large diameter Belleville springs calibrated with a load scale for use with higher process pressures. The load scale provides a visual indication of packing load as well as packing wear, making it easier for you to determine when additional torquing might be required.

KALREZ with Vespel CR-6100 Packing

The KALREZ pressure/temperature limits referenced in this bulletin are for Fisher valve applications only. DuPont may claim higher limits.

KALREZ packing is available in KVSP 500 (260°C / 500°F service). The KVSP 500 series uses DuPont material called Vespel CR-6100, which is a carbon fiber-reinforced PTFE.

Lubrication Recommendations for the enhanced ENVIRO-SEAL Packing Systems

Lubrication is required for the packing studs and nuts. While it is important to properly lubricate the stud threads and internal nut threads, it is also important to properly lubricate the contacting face of the nut.

Do not lubricate any of the enhanced ENVIRO-SEAL packing components or the bonnet bore prior to assembly. Lubrication is often used as part of standard valve assembly techniques. However, lubrication is not required for the enhanced ENVIRO-SEAL packing systems.

Figure 12. Applications Guidelines Chart for 100 PPM Service per EPA Method 21 (FCI 91-1)

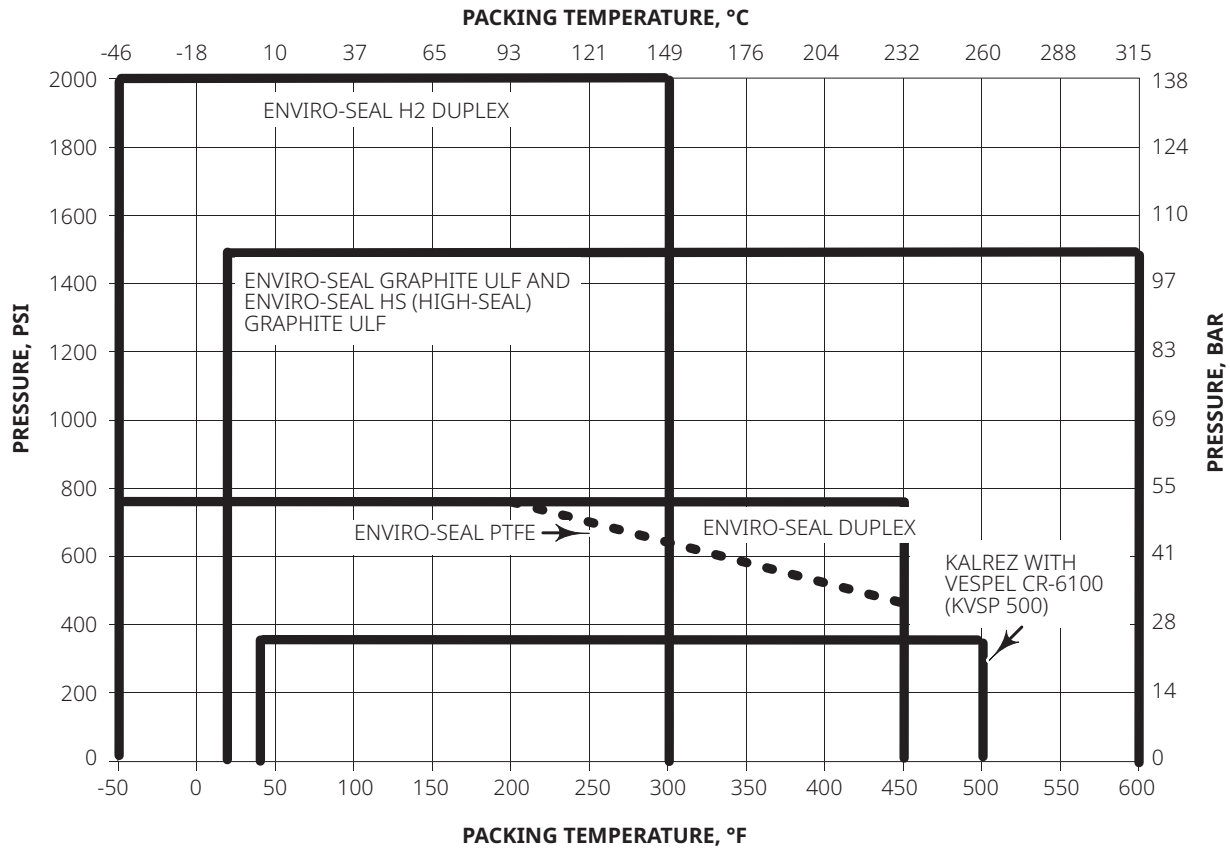

Non-Live-Loaded Packing

Table 2. Fisher Non-Live-Loaded Packing Selection Guidelines for Sliding-Stem Valves

Non-Live-Loaded Packing	Seal Performance Index	Service Life Index	Packing Friction	ENVIRO-SEAL Bellows Compatible	Packing Material
Single PTFE V-Ring	Better	Long	Low	●	Solid rings of molded PTFE
Double PTFE V-Ring	Better	Long	Low	●	Solid rings of molded PTFE
Graphite Composite	Better	Very Long	Very High		Solid rings of ribbon-style graphite with sacrificial zinc washers
Braided Graphite Filament (Single and Double)	Good	Moderate	High	●	Ribbon-style graphite rings and rings of braided graphite fibers with sacrificial zinc washers
Graphite ULF	Better	Very Long	Medium	●	Laminated graphite rings

● Indicates availability

Figure 13. Applications Guidelines Chart for Services Not Requiring Fugitive Emission Control

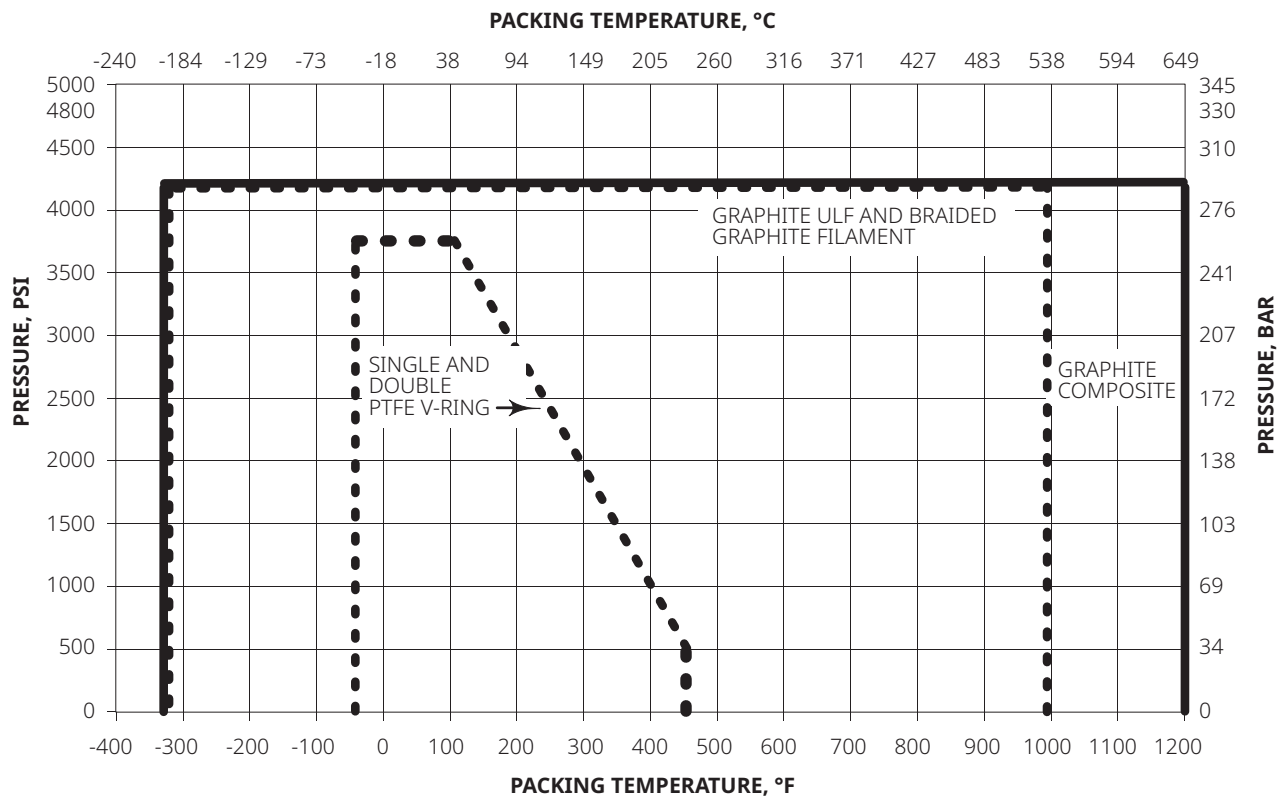

Single Packing Arrangements

Single packing arrangements offer an economical seal in the majority of applications. Single packing consists of a stack of packing at the top of the packing box supported by either a spring or lantern rings. Spring-type packing can be recognized as having the packing follower drawn against the bonnet to compress the spring. This type of packing is non-adjustable. Springs are not available in all alloy materials. If a special alloy is required, it may be necessary to consider packing with lantern rings.

Jam-type packing (with lantern rings) will have a gap between the packing follower shoulder and bonnet. Single packing arrangements are available in PTFE V-ring, graphite ribbon/filament and graphite composite packings. Typically, the packing flange nuts will be tightened upon shipment. Final adjustments will normally be required to limit stem leakage as a valve is being put into service. Refer to the appropriate valve body instruction manual for recommended procedures. Single packing arrangements are illustrated in Figures 18 and 19.

Single PTFE V-Ring Packing

The single PTFE V-ring arrangement uses a coil spring or lantern ring. This packing arrangement offers very good seal performance with the lowest packing friction.

Double Packing Arrangements

Double packing arrangements are available in all materials shown in Table 2. Double packing arrangements provide a more rugged seal than single packing arrangements and generally have more packing above than below the lubricating connection (in some cases there is an equal amount above and below the lubricating connection). Double packing arrangements are illustrated in Figures 15 through 19.

Figure 14. Packing Arrangement with Single PTFE V-Ring

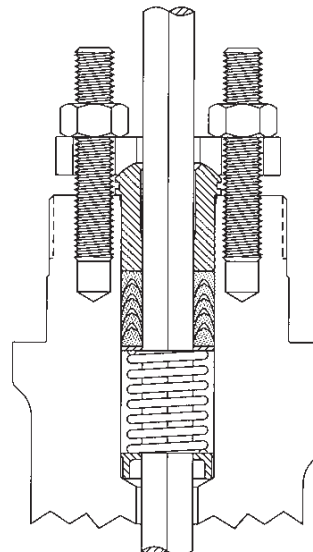

A6161-1

Body/Bonnet Availability

Single and double packing arrangements can be used on all valves that will accept the plain bonnet, the style 1 cast extension bonnet, the style 2 cast extension bonnet, the style 3 fabricated or cast extension bonnet or the bellows seal bonnet.

Temperature Ranges

When using any packing at low temperatures, frost must not be allowed to form on the valve stem. Valve stem frost can damage packing as the stem travels.

For packing box temperatures above 427°C / 800°F, an extension bonnet or steel actuator yoke should be used along with high-temperature packing. When using graphite or graphite ribbon/filament packing at high temperatures, it is not necessary to have a chrome-coating on the valve stem because these packings are non-abrasive.

Oxygen Service

Due to the highly combustible nature of most lubricants or foreign material in the presence of liquid or gaseous oxygen, special precautions must be taken in the cleaning and handling of oxygen service equipment. Emerson offers this special cleaning service for equipment ordered. Be sure to specify oxygen service when ordering packing or other equipment for this purpose.

Radiation Resistance

Graphite ribbon/filament packing is essentially impervious to radiation and is suitable for nuclear service. It will withstand gamma radiation dosages to 1.7×10^8 Rads and can be certified to contain no more than 100 ppm of leachable chloride.

Figure 15. Typical Single PTFE V-Ring Packing Arrangement

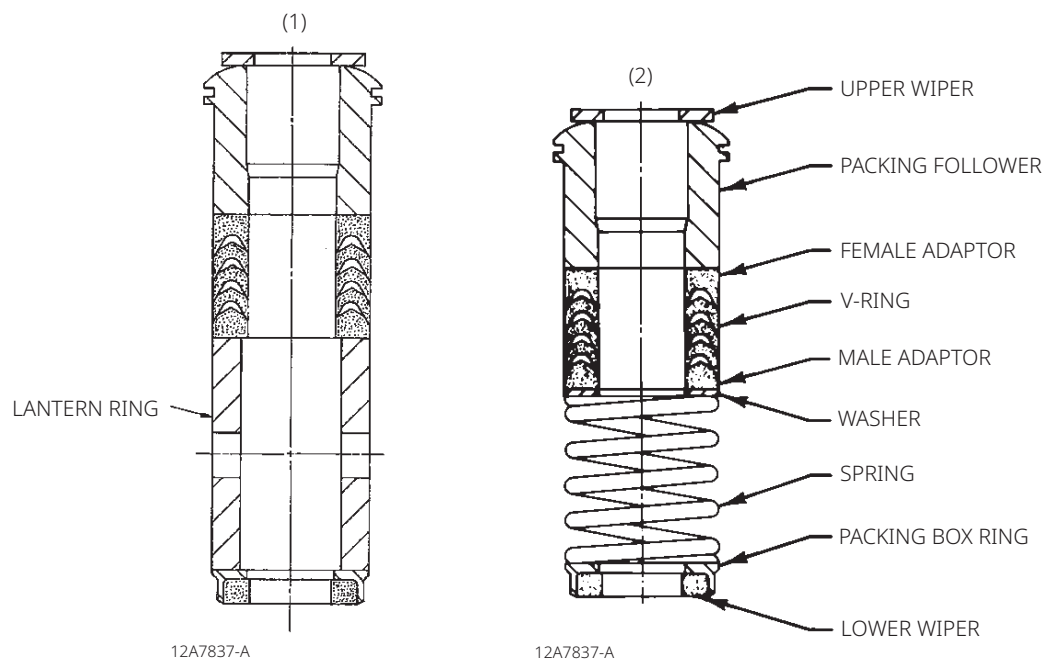

NOTES:

- 1. USED WITH ALLOY TRIM
- 2. USED WITH SST TRIM

Figure 16. Typical Double PTFE V-Ring Packing Arrangement

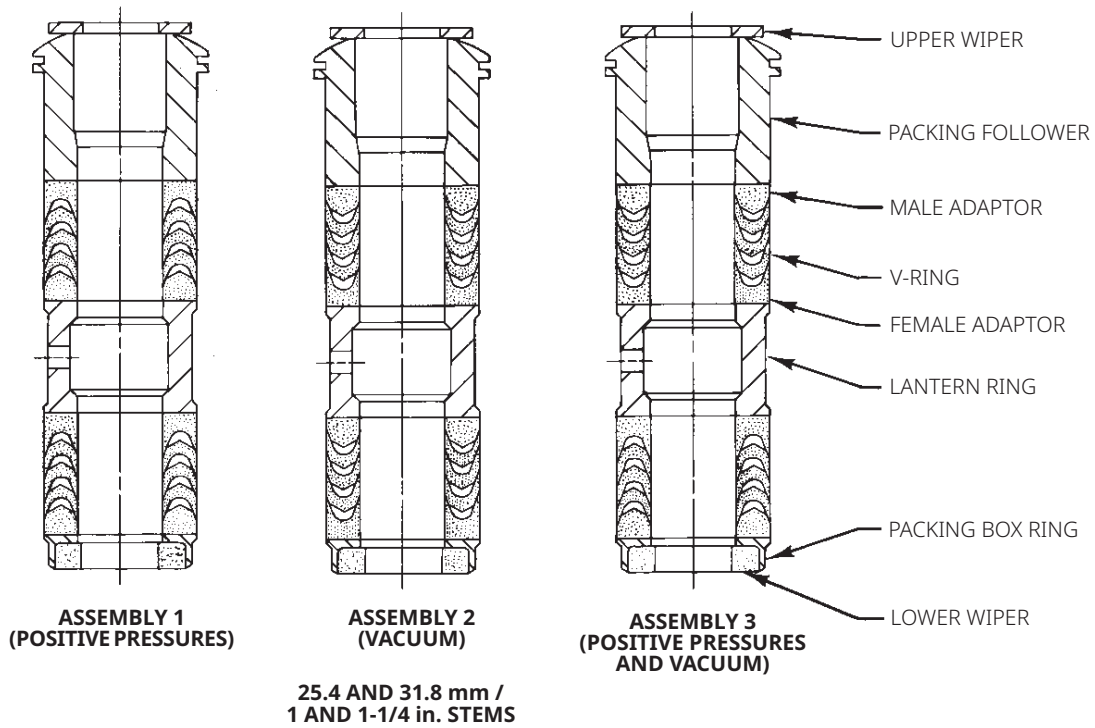

12A7839-A
B0736-2

Figure 17. Typical Single and Double Graphite Composite Packing Arrangements

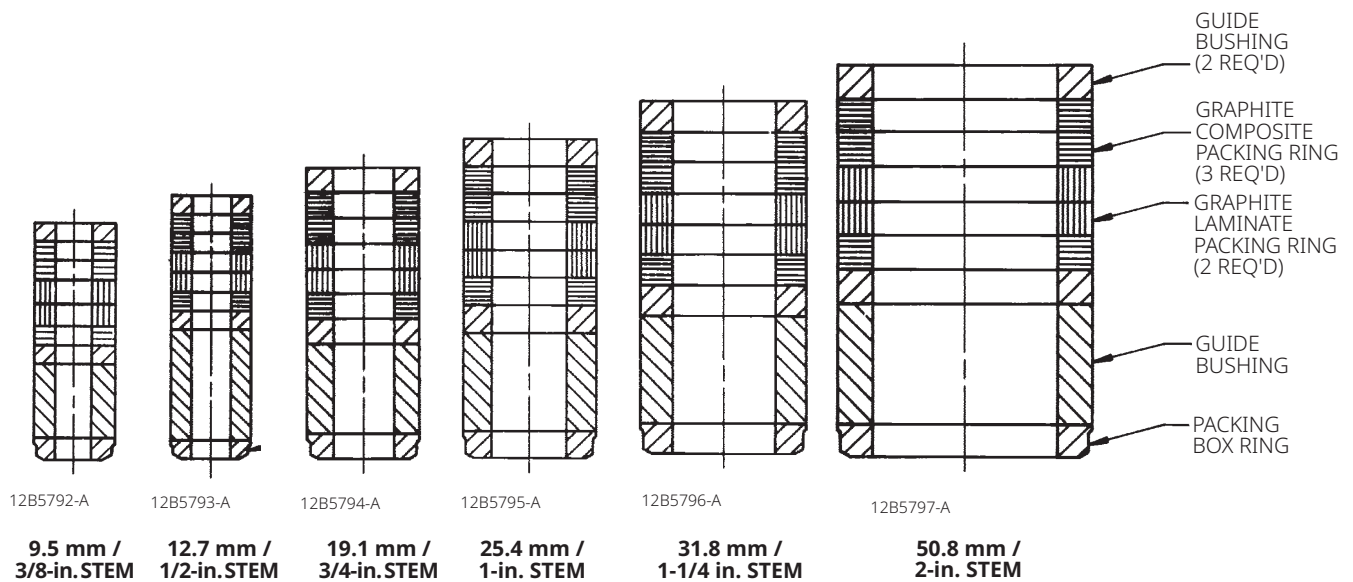
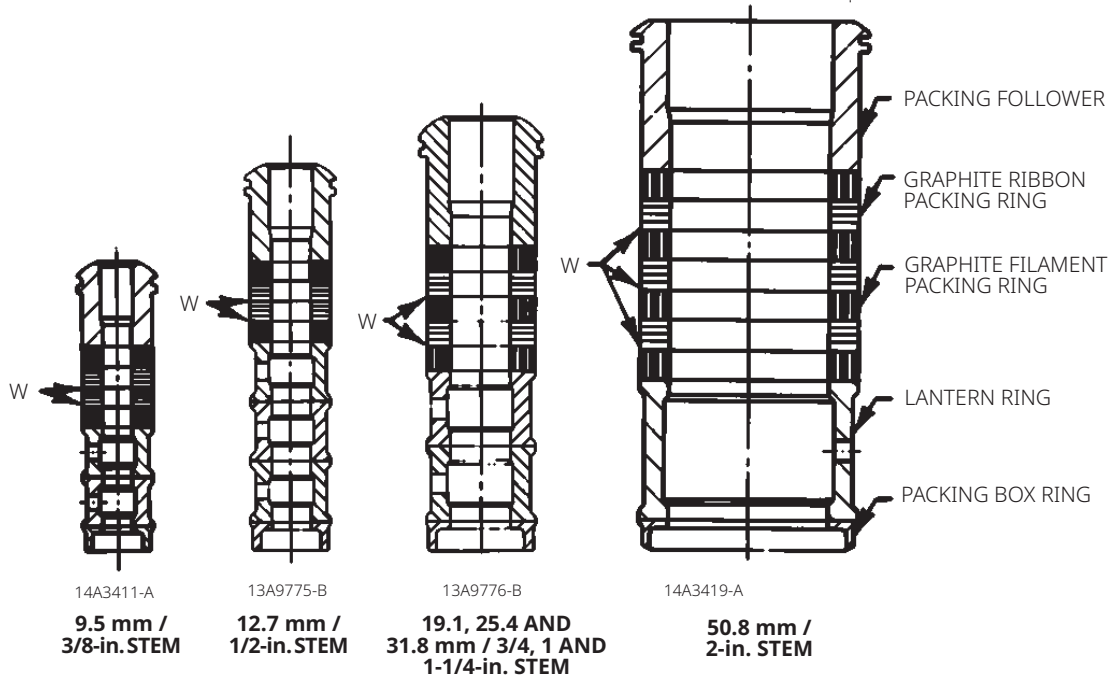

Figure 18. Typical Single and Double Braided Graphite Filament Packing Arrangement



A2375-2

NOTE: INSTALL SACRIFICIAL WASHERS AT PLACES MARKED "W".

Figure 19. Typical Double PTFE Impregnated Composition Packing Arrangement

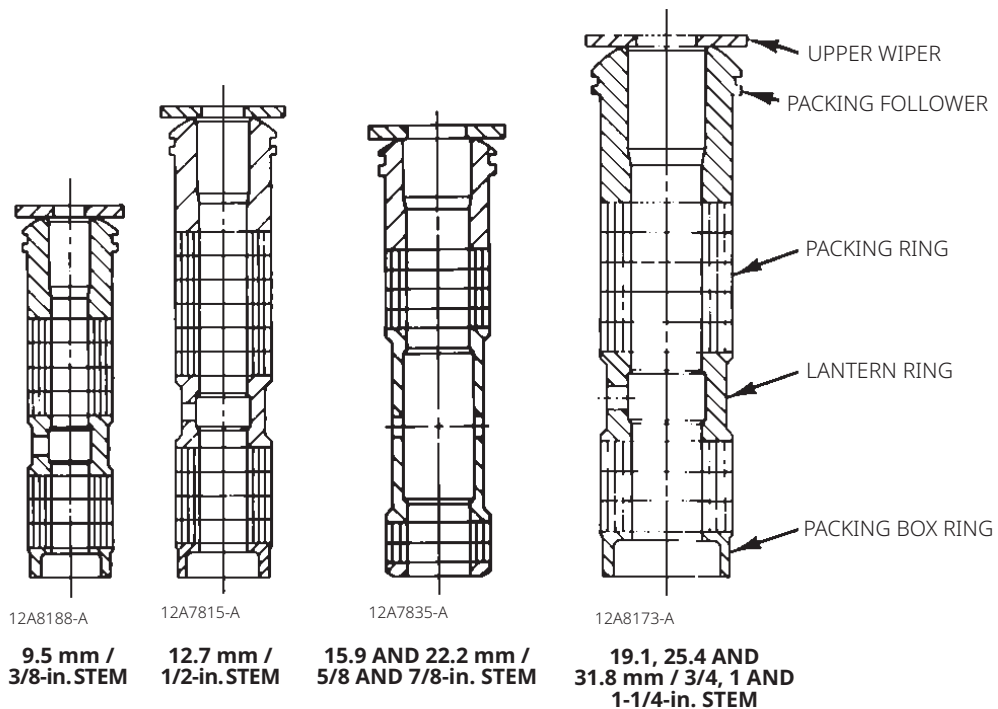

A1491-2

Conclusion

Fisher provides packing systems which have been engineered for fugitive emission control and extended service life.

The enhanced ENVIRO-SEAL packing systems offer exceptional stem sealing capabilities to protect the environment and provide an opportunity to “engineer” the packing selection for the application. A proper packing system improves service life and reduces maintenance.

For all packing systems, it is important to recognize that many parameters affect seal performance and service life. Even if the optimum design is selected, other factors such as stem finish, packing bore finish and job site installation and maintenance practices will influence performance. If you need a more detailed engineering discussion of the design principles affecting packing seal design contact your [Emerson sales office](#).

Ordering Information



When ordering, specify:

For Existing Valves

1. Process fluid
2. Process fluid temperature
3. Maximum valve inlet pressures
4. Maximum valve pressure drops
5. Valve design (ED, YD, etc.), size and pressure rating
6. Valve stem diameter and bonnet type (plain, extension or bellows)
7. Refer to the specifications. Review the information under each specification. Write down your choice whenever a selection is to be made.

For New Valves

1. Refer to the valve bulletin for ordering information.
2. Also refer to the specifications. Review the information under each specification and in the referenced tables; write down your choice whenever there is a selection to be made.

 [LinkedIn.com/groups/3941826](https://www.linkedin.com/groups/3941826)
 [Fisher.com](https://www.fisher.com)

 [Facebook.com/FisherValves](https://www.facebook.com/FisherValves)
 [X.com/FisherValves](https://www.x.com/FisherValves)

D101986X012 © 1993, 2026 Emerson. All rights reserved. The Emerson logo is a trademark and service mark of Emerson Electric Co. Fisher, easy-e, and ENVIRO-SEAL are marks of an entity in the Emerson family of businesses. All other marks are the property of their respective owners.

Neither Emerson nor any of its affiliated entities assume responsibility for the selection, use or maintenance of any product. Responsibility for proper selection, use, and maintenance of any product remains solely with the purchaser and end user.

The contents of this publication are presented for informational purposes only, and while every effort has been made to ensure their accuracy, they are not to be construed as warranties or guarantees, express or implied, regarding the products or services described herein or their use or applicability. All sales are governed by our terms and conditions, which are available upon request. We reserve the right to modify or improve the designs or specifications of such products at any time without notice.

Emerson
Marshalltown, Iowa 50158 USA
Sorocaba, 18087 Brazil
Cernay, 68700 France
Dubai, United Arab Emirates
Singapore 128461 Singapore

www.fisher.com

FISHER™

EMERSON™