

Damcos™ CBF-E

Control Block

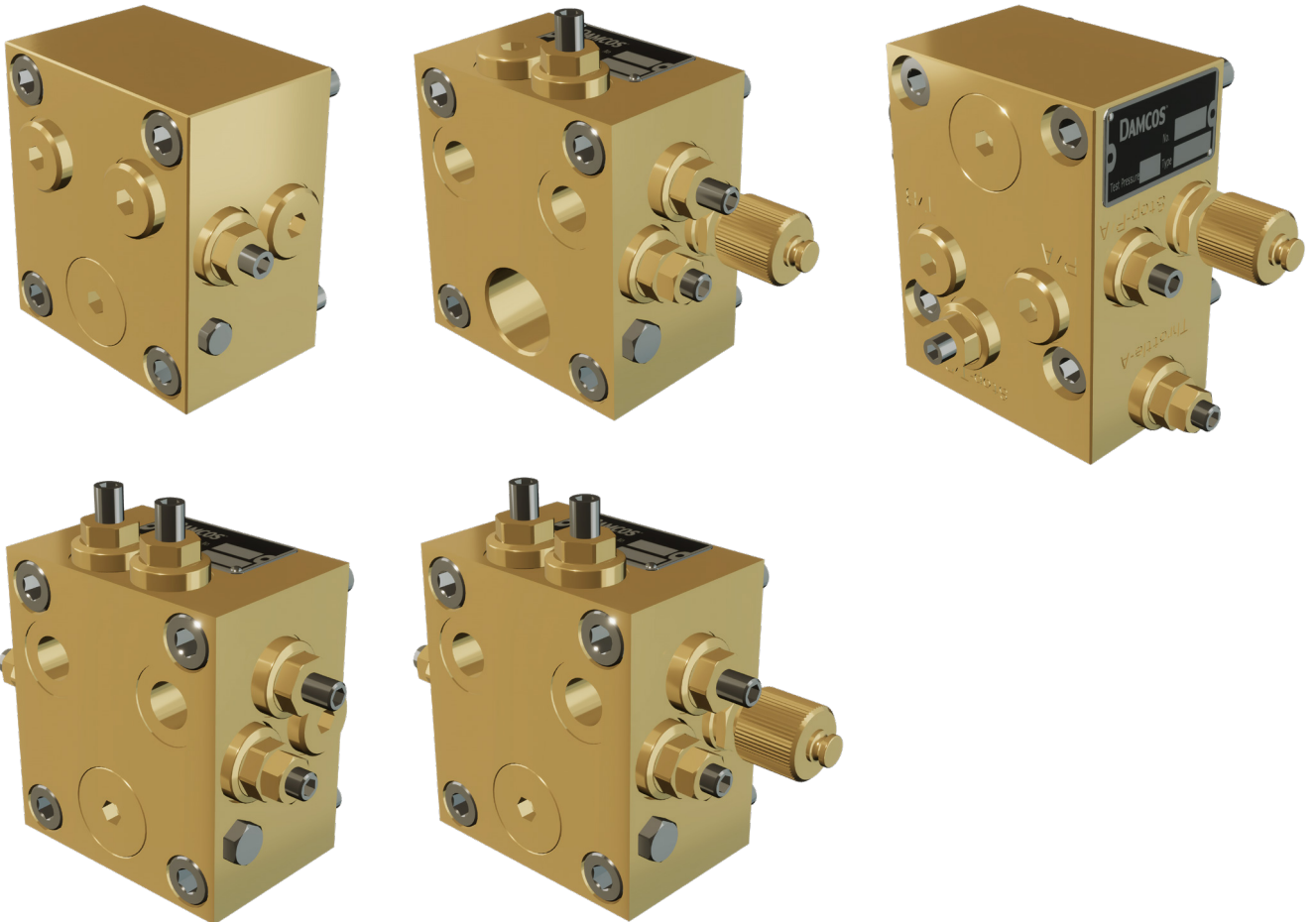

Available Types

- CBF 2-NG6-PCV-R-T-H-(E)
- CBF 2-PCV-R-T-H-E
- CBF 2-PCV-R-T-E
- CBF 2-T-H-E
- CBF 2-T-E
- CBF 1-T-H-E
- CBF 1A-T-H-E

CBF-E Control Block

Control block for mounting on 1-line and 2-line actuators. This block is with a flush system and it is mounted with interface for EL on/off or potentiometer. It is prepared for pilot operated check valve, relief valve and throttle valve, stop valve and hand pump quick connections.

Main Dimensions

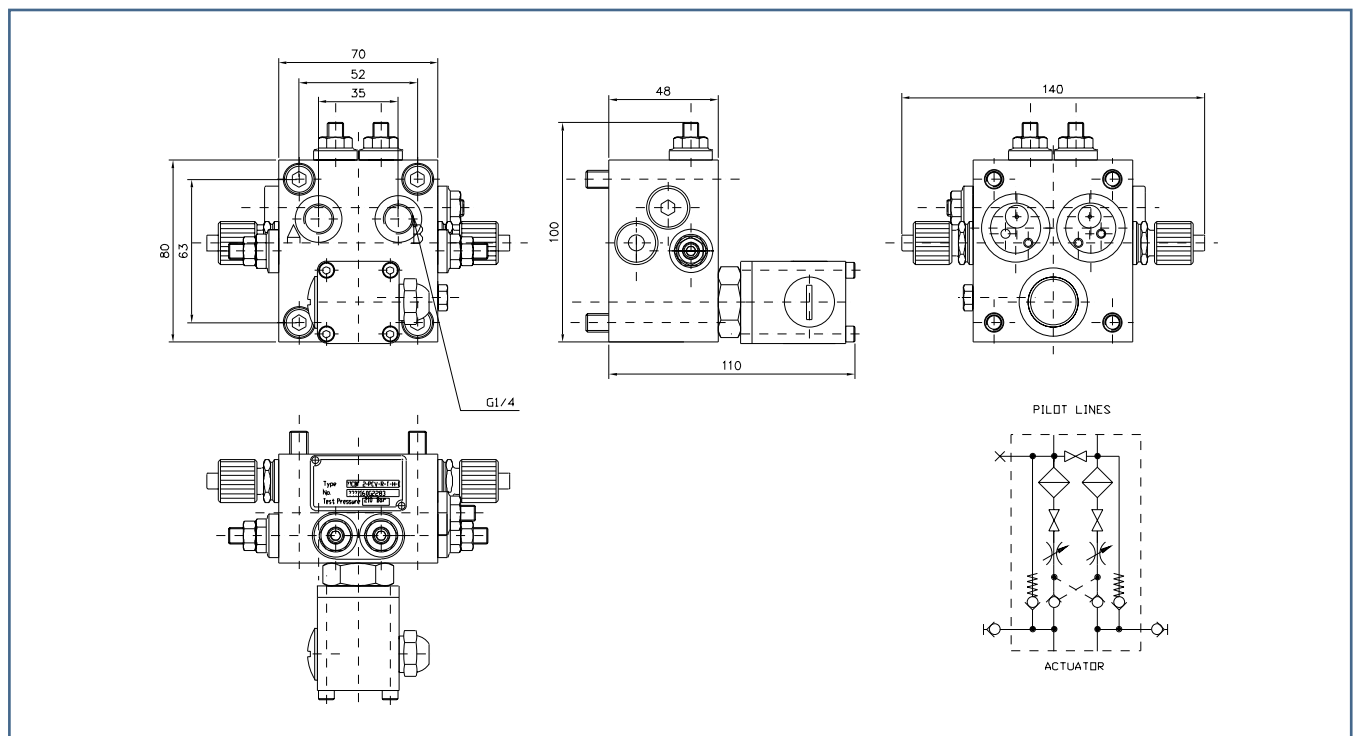

©2020 Emerson. All rights reserved.

The Emerson logo is a trademark and service mark of Emerson Electric Co. Damcos and the Damcos logotype are trademarks of Damcos A/S. Damcos is a member of the Emerson family of companies. All other marks are the property of their respective owners.

Emerson Automation Solutions

Damcos A/S
Aaderupvej 41
DK-4700 Naestved
T +45 5578 7200
F +45 5578 7272

www.Emerson.com/marine

The contents of this publication are presented for information purposes only, and while effort has been made to ensure their accuracy, they are not to be construed as warranties or guarantees, expressed or implied, regarding the products or services described herein or their use or applicability. Standard Terms and Conditions of Sale can be issued by contacting Damcos A/S. We reserve the right to modify or improve the designs and specifications of our products at any time without notice. Damcos A/S accepts no responsibility for any errors that may appear in this publication.