

# DeltaV™ SX Controller

- Scalable controllers
- Quick assembly
- Easy-to-use
- Field proven architecture
- Designed for Electronic Marshalling
- Advanced controls



The DeltaV™ SX Controller and the DeltaV I/O subsystem make rapid installation easy.

## Introduction

The DeltaV™ SX controller provide communication and control functions and integrate field devices and the other nodes on the control network. The SX and SQ controllers provide a choice to match the controller capacity to the requirements of the process. They also provide new ease of use features that eliminate mounting screws and accelerate cabinet assembly.

Control strategies and system configurations created on earlier DeltaV systems can be used with this powerful controller. The SX Controller provides all the features and functions of the M-series controllers including support for CHARM based Electronic Marshalling.

The control languages executed in the controllers are described in the Control Software product data sheet.

## Benefits

**Scalable Controllers.** The SX controller complements the SQ controller by providing additional CPU and Memory for those applications that need more control capacity:

- **Late Changes.** You can easily upgrade an SD Plus or SQ controller to an SX to handle project scope changes late in the project. Simply replace the SD Plus or SQ with the SX and all existing configuration, documentation and hardware design remain the same — *forgiving*.
- **Speed.** The SX controller supports all the features you've come to expect from the DeltaV system: self-addressing, automatic I/O detection. All these features are designed to make your projects execute faster — *just plug and play!*
- **Redundant Architecture.** The SX controller supports 1:1 redundancy for increased availability. Redundant SD Plus or SQ controllers can be upgraded to SX controllers online — *robust!*

**Quick Assembly.** The S-series hardware has been designed for speed of project execution. Carriers snap to standard DIN rails and controllers and S-series IO snap into position without the use of retaining screws.

**Easy to Use.** Controllers are also easy to configure. Simply connect the SX to the DeltaV network and auto-sense it from DeltaV Explorer. Add the controller and all its IO cards to the system database and all components are automatically addressed and communicating.

- Control strategies are developed using IEC-61131 programming techniques: Function Blocks, Sequential Function Charts and Structured Text.
- Automatic diagnostics and event reporting with time stamps applied in the controller.
- Set control execution to match process dynamics and controller scheduling adjusts automatically.
- Reference any parameter by its module name, regardless of its location in the system.
- Synchronized system clock for consistent time based event driven actions across the system.
- Online expandable IO carriers allow new cards to be added online, with autosense capability, for modular system growth.
- Hardware redundancy is automatically detected with zero configuration effort.

**Field Proven Architecture.** The SX controller is an evolution of the DeltaV MX controller. The new design delivers installation and robustness enhancement while still using the same processor and OS that has proven itself in the field. All IO cards run the latest software enhancements of corresponding M-series IO cards and deliver the same field proven, reliable operation.



*The SX Controller.*

**Designed for Electronic Marshalling.** The SX controller have highly distributable IO capabilities with CHARMs based Electronic Marshalling. Electronic Marshalling IO can be mounted anywhere, facilitating system design and expansion while reducing overall system footprint over traditional marshalled IO Subsystems.

**Advanced Controls.** The SX controller supports all the advanced control features that are expected in a world class Distributed Control System:

- Batch Software
- Model Predictive Control
- Neural Networks

## Product Description

The SX controller primary function is to execute control modules that are designed to meet the specific control requirements of the plant. These control modules use process signals from the controller's I/O subsystem and provide communication of process data to the rest of the DeltaV control system for operator interaction and data collection.

Each controller node can be installed as a simplex or redundant node. The controllers are connected to the I/O carriers, which are mounted to the right of the controller carriers. Up to 8 carriers with 8 cards each can be connected to the local bus I/O, for a total of 64 traditional I/O cards. In addition to the 8 local I/O carriers, each controller can communicate with an additional 16 Remote I/O units hosting traditional card based I/O.

In addition to traditional I/O cards, the local bus supports fieldbus technologies, including FOUNDATION Fieldbus, Profibus DP, DeviceNet and AS-i protocols. The I/O subsystem also supports Serial interface cards as well as the Ethernet I/O interface. These various I/O products provide a wide range of interfaces to meet the needs of your control application.

The SX controller also supports CHARMs and *WirelessHART* I/O cards. The CHARM I/O Card (CIOC) connects via the redundant Ethernet ports of the controller to provide a highly distributed and flexible I/O solution called Electronic Marshalling. Up to 16 CIOC's can communicate to one controller, each providing up to 96 individually configurable signal types.

The capacity limits of the SX controller may vary depending on the particular application, amount of CHARM I/O Signals and as well control performance requirements. Enhanced memory handling and hardware alerts covering capacity and memory, via indexes, got added to the diagnostic information of the SX Controller.

The *WirelessHART* I/O card (WIOC) provides redundant communication for up to 100 *WirelessHART* devices, providing high availability and reliability of wireless data. Up to 16 *WirelessHART* I/O cards can communicate to one controller, each providing up to 100 signals.

Control modules are automatically scheduled by the controller, based on their assigned scan rates. This allows each control function to be optimized based on the process dynamics. Modules scan times can be set as fast as 100 ms, and as slow as 60 seconds. The number of control modules that can be assigned to a controller depends on the complexity and scan rate of each module, and the available CPU and memory. The SX controller should be used for medium to large applications with a maximum of 1500 individual I/O signals.

The SX controller is designed for harsh environments and is rated for G3 corrosive environments, with an operating temperature range from -40 to 60°C. It is ideally suited for larger units with higher I/O counts. It can be field mounted close to the equipment, or centrally located in an equipment room. For more traditional installations with central marshalling cabinets, CHARM I/O cards can be mounted in standard I/O cabinets providing Electronic Marshalling. CHARM I/O cards can also be used for highly distributed I/O applications.

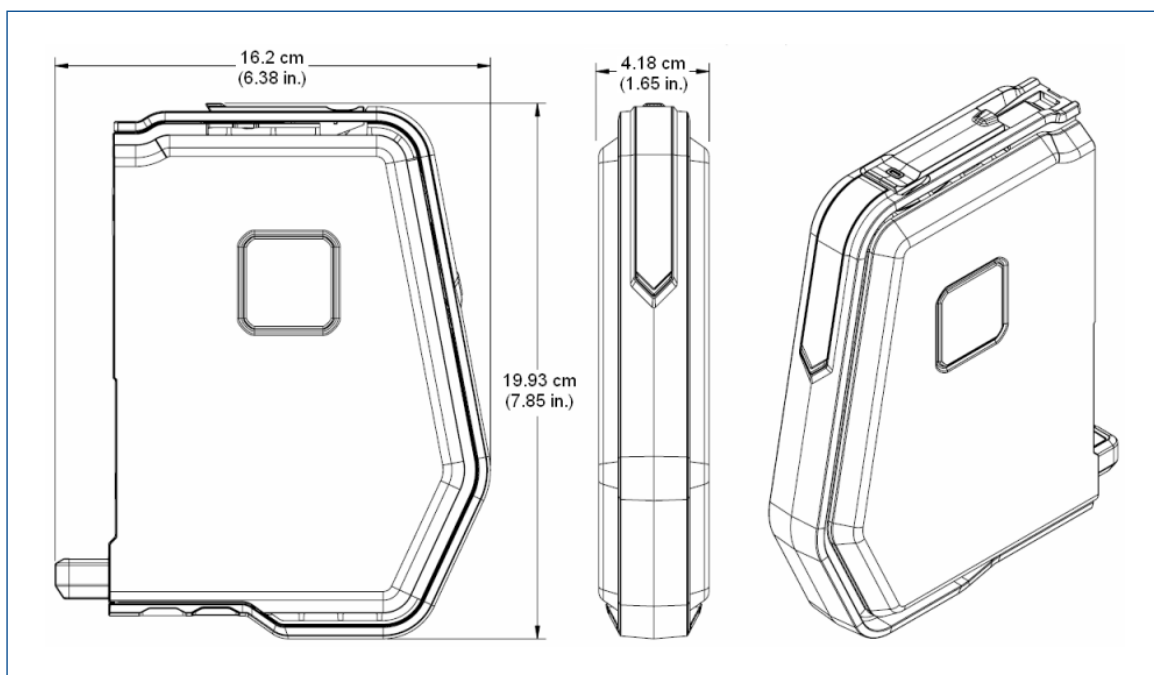

*DeltaV SX controller hardware dimensions.*

## Hardware Specifications

Specifications for the SX Controller	
DST Limit	1500
SCADA Tags	3200
Max Data Values Sent	4000/second
Max Data Values Received	500/second
Max Unsolicited Client Nodes	120
Module Execution Rates	100ms, 200ms, 500ms, 1s, 2s, 5s, 10s, 30s, 60s
User Memory	96 MB
Fuse Protection (Internal)	3.0 A, non-replaceable fuses
Power Dissipation	5.0 W typical, 7.0 W maximum
Environmental Specifications	
Operating Temperature	-40° to 60°C (-40° to 140°F)
Storage Temperature	-40° to 85°C (-40° to 185°F)
Relative Humidity	5 to 95%, non-condensing
Protection Rating	IP 20
Airborne Contaminants	ISA-S71.04-1985 Airborne Contaminants Class G3 Conformal coating
Shock (Normal Operating Conditions)	10 g ½-sine wave for 11 ms
Vibration (Operative Limit)	1 mm peak-to-peak from 5 Hz to 13.2 Hz, 0.7 g from 13.2 Hz to 150 Hz
LED Indicators	
Green – Power	Indicates DC power is applied
Red – Error	Indicates an error condition
Green – Active	Indicates that the controller is operating as the primary controller
Green – Standby	Indicates that the controller is operating as a backup controller (reserved for future use)
Yellow Flashing – Pri. CN	Indicates valid primary control network communication
Yellow Flashing – Sec. CN	Indicates valid secondary control network communication
External Connections	
Primary Control Network	8-pin RJ-45 connector
Redundant Control Network	8-pin RJ-45 connector

## Certifications

The following certifications are available on the DeltaV SX controller (see actual certificates for exact certifications).

- **CE:**
  - EMC- EN 61326-1
- **FM:**
  - FM 3600
  - FM 3611
- **CSA:**
  - CSA C22.2 No. 213-M1987
  - CSA C22.2 No. 1010-1
- **ATEX:**
  - EN 60079-0
  - EN 60079-7
- **IEC Ex:**
  - IEC60079-0
  - IEC60079-7
- **Marine Certifications:** IACS E10
  - ABS Certificate of Design Assessment
  - DNV Type Approval Certificate
- **Wurldtech:**
  - Achilles Communications Certification Level 2

## Hazardous Area/Locations

The DeltaV SX Controller can be installed and used based on the following Standards (see actual certificates for exact product markings):

- **FM (USA):**
  - Installation:  
Class I, Division 2, Groups A, B, C, D, T4
- **cFM (Canada):**
  - Installation:  
Class I, Division 2, Groups A, B, C, D, T4
- **ATEX:**
  - II 3G Ex ec IIC T4 Gc
- **IEC Ex:**
  - Installation:  
II 3G Ex ec IIC T4 Gc

*Regarding the installation instructions please refer to the following documents:  
Class 1 Division 2 Installation Instructions DeltaV S-Series (12P5402)  
Zone 2 Installation Instructions DeltaV S-series (12P5404)*

## Ordering Information

Description	Model Number
SX Controller	SE3007

## Prerequisites

- For each controller you will need a power controller carrier. Please refer to the S-series Horizontal Carriers product data sheet for details.
- Each controller requires a dedicated system power supply. Please refer to the S-series Power Supplies product data sheet for details.

©2024, Emerson. All rights reserved.

The Emerson logo is a trademark and service mark of Emerson Electric Co. The DeltaV logo is a mark of one of the Emerson family of companies. All other marks are the property of their respective owners.

The contents of this publication are presented for informational purposes only, and while diligent efforts were made to ensure their accuracy, they are not to be construed as warranties or guarantees, express or implied, regarding the products or services described herein or their use or applicability. All sales are governed by our terms and conditions, which are available on request. We reserve the right to modify or improve the designs or specifications of our products at any time without notice.

### Contact Us

[www.emerson.com/contactus](http://www.emerson.com/contactus)