

# Micro Motion™ High Pressure Coriolis Flow Meters

Global industry standard for ultra high pressure applications



[VIEW PRODUCT >](#)

- A Coriolis mass flow meter designed for high pressure applications up to 16,401 psi (1,131 bar), such as chemical injection for the oil and gas industry and hydrogen dispensing
- Complies with the high pressure piping requirements of ASME B31.3 Process Piping Code, SAE J2601-1, and the European Pressure Equipment Directive 2014/68/14 EU (PED)
- Micro Motion MVD™ Direct Connect™ technology for space and weight savings
- Variety of transmitter options provide multivariable outputs to accommodate any design requirements
- Compact design with no moving parts, no special mounting, or flow conditioning required
- Smart Meter Verification™ delivers complete online verification of device health and performance, continuously or on-demand at the press of a button

## Micro Motion HPC meter

Micro Motion High Pressure Coriolis (HPC) meters are specifically designed to meet the challenges of ultra high pressure applications. The unique meter design provides customers a highly accurate and reliable solution in high pressure applications where flow measurement is critical.

### Coriolis meters

Coriolis meters offer dramatic benefits over traditional volumetric measurement technologies. Coriolis meters:

- Deliver accurate and repeatable process data over a wide range of flow rates and process conditions.
- Provide direct inline measurement of mass flow and density, and also measure volume flow and temperature—all from a single device.
- Have no moving parts, so maintenance costs are minimal.
- Have no requirements for flow conditioning or straight pipe runs, so installation is simplified and less expensive.
- Provide advanced diagnostic tools for both the meter and the process

### HPC meters

HPC meters are offered with MVDSolo™, 1500, 1700, 2200, 2400, 2500, 2700, 4200, and 5700 transmitters with MVD technology. You can choose single or multivariable output configurations with milliamp, pulse, dual pulse, digital outputs, and an integral display.

For installations with space and weight limitations, the HPC meters are available with Micro Motion MVD Direct Connect technology, eliminating the need for an external transmitter.

### Access information when you need it with asset tags

Newly shipped devices include a unique QR code asset tag that enables you to access serialized information directly from the device. With this capability, you can:

- Access device drawings, diagrams, technical documentation, and troubleshooting information in your MyEmerson account
- Improve mean time to repair and maintain efficiency
- Ensure confidence that you have located the correct device
- Eliminate the time-consuming process of locating and transcribing nameplates to view asset information

## Measurement principles

As a practical application of the Coriolis effect, the Coriolis mass flow meter operating principle involves inducing a vibration of the flow tube through which the fluid passes. The vibration, though it is not completely circular, provides the rotating reference frame which gives rise to the Coriolis effect. While specific methods vary according to the design of the flow meter, sensors monitor and analyze changes in frequency, phase shift, and amplitude of the vibrating flow tubes. The changes observed represent the mass flow rate and density of the fluid.

### Mass and volume flow measurement

The measuring tubes are forced to oscillate producing a sine wave. At zero flow, the two tubes vibrate in phase with each other. When flow is introduced, the Coriolis forces cause the tubes to twist resulting in a phase shift. The time difference between the waves is measured and is directly proportional to the mass flow rate. Volume flow rate is calculated from mass flow rate and the density measurement.

Watch this video to learn more about how a Coriolis flow meter measures mass flow and density (click the link and select **View Videos**): <https://www.emerson.com/en-us/automation/measurement-instrumentation/flow-measurement/coriolis-flow-meters>.

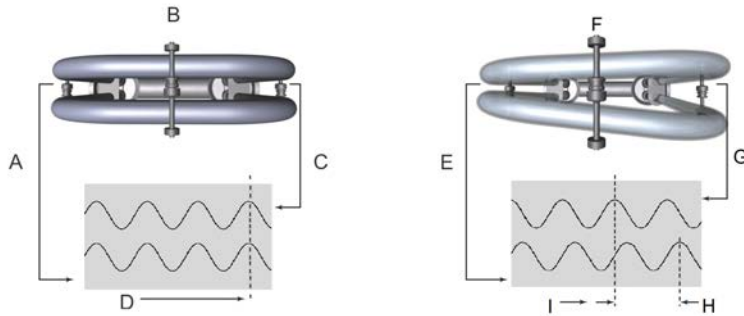

- A. Inlet pick off displacement
- B. No flow
- C. Outlet pick off displacement
- D. Time
- E. Inlet pick off displacement
- F. With flow
- G. Outlet pick off displacement
- H. Time difference
- I. Time

## Performance specifications

### Reference operating conditions

For determining the performance capabilities of our meters, the following conditions were observed / utilized:

- Water at 68 °F (20 °C) to 77 °F (25 °C) and 14.5 psig (1 barg) to 29 psig (2 barg), installed in a tubes-down orientation
- Air and natural gas at 68 °F (20 °C) to 77 °F (25 °C) and 500 psig (34 barg) to 1,450 psig (100 barg), installed in a tubes-up orientation
- Accuracy based on industry leading accredited calibration standards according to ISO 17025/IEC 17025

### Accuracy and repeatability on liquids, gases, and temperature

#### Accuracy and repeatability on liquids

Performance	Premium option	Standard option
Mass flow and volume flow accuracy <sup>(1)</sup>	±0.10% of rate	0.20% of rate
Mass flow and volume flow repeatability	0.05% of rate	0.10% of rate
Density accuracy	±1 kg/m <sup>3</sup> (±0.001 g/cm <sup>3</sup> )	
Density repeatability	0.5 kg/m <sup>3</sup> (0.0005 g/cm <sup>3</sup> )	

(1) Stated performance is at standard reference conditions.

**Accuracy and repeatability on gasses**

Performance specification	Standard models
Mass flow and volume flow accuracy	±0.5% of batch
Mass flow and volume flow repeatability	0.25% of batch

**Accuracy and repeatability on temperature**

Performance specification	Standard models
Temperature accuracy	±1 °C ±0.5% of reading
Temperature repeatability	0.2 °C

**Warranty**

**Warranty options on all HPC models**

The warranty period is generally initiated from the day of shipment. For warranty details, see the *Terms and Conditions* included with the standard product quote.

Base model	Included as standard	Included with start-up service	Available for purchase
HPC015M/N/P/H HPC020M/N	18 months	36 months	> 36 months (customizable length)

**Liquid flow rates**

**Nominal flow rate**

Micro Motion has adopted the term nominal flow rate, which is the flow rate at which water at reference conditions causes approximately 14.5 psig (1 barg) of pressure drop across the meter.

**Mass flow rates**

Model	Nominal flow rate			Maximum flow rate		
	lbm/min	kg/min	kg/h	lbm/min	kg/min	kg/h
HPC015M/N/P	6.5	3.0	176	13.2	6.0	360
HPC015H	5.7	2.6	155	13.2	6.0	360
HPC020M	20	9.0	540	35	16	960
HPC020N	17	7.7	462	31	14	840

**Volume flow rates**

Model	Nominal flow rate			Maximum flow rate		
	gal/min	l/min	l/h	gal/min	l/min	l/h
HPC015M/N/P	0.78	3.0	176	1.6	6	360
HPC015H	0.68	2.6	155	1.6	6	360
HPC020M	2.3	9.0	540	4.2	16	960
HPC020N	2.0	7.7	462	3.6	14	840

## Gas flow rates

When selecting sensors for gas applications, pressure drop and turndown through the sensor is dependent upon operating temperature, pressure, and fluid composition. Therefore, when selecting a sensor for any particular gas application, Emerson highly recommends that each sensor be sized using the [Flow Measurement Sizing & Selection Tool](#), which will report both the actual velocity and the sonic velocity for each flow rate and meter size considered.

For complete list of sensor tube IDs, refer to [Flow tube information](#).

Use the following equation to determine general recommendations on nominal and maximum gas mass flow rates:

$$\dot{m}_{(gas)} = \%M * \rho_{(gas)} * VOS * \frac{1}{4}\pi * D^2 * 2 * (3600 \text{ s/hr})$$

- $\dot{m}_{(gas)}$  Gas mass flow rate
- $\%M$  Use Mach number "0.2" for calculating typical nominal flow rate; use Mach number "0.3" for calculating maximum recommended rate. When Mach numbers are above 0.3, most gas flows become compressible and significant increases in pressure drop may occur regardless of measurement device.
- $\rho_{(gas)}$  Gas density at operating conditions
- $VOS$  Velocity of sound of the measured gas
- $D$  Internal diameter of the measuring tube

### Sample calculation

The following calculation is an example of the maximum recommended gas mass flow rate for an HPC015M measuring hydrogen with a molecular weight of 2.02 at 40 °F (4 °C) and 6,000 psig (413.69 barg):

$$\dot{m}_{(gas)} = 0.3 * 32.45 \text{ (kg/m}^3\text{)} * 1161.95 \text{ (m/s)} * \frac{1}{4}\pi * 0.0023 \text{ m}^2 * 2$$

$\dot{m}_{(gas)} = 5.7 \text{ kg/min}$ ; maximum recommended rate for HPC015M with hydrogen gas at given conditions

- $\%M$  0.3 (used for calculating maximum recommended rate)
- $\rho(\text{Gas})$  32.45 kg/m<sup>3</sup>
- $VOS$  1161.95 m/s (Velocity of Sound of H<sub>2</sub> at given conditions)
- $D$  0.00231 m (HPC015M tube ID)

## Zero stability

Zero stability is used when the flow rate approaches the low end of the flow range where the meter accuracy begins to deviate from the stated accuracy rating, as depicted in the turndown section. When operating at flow rates where meter accuracy begins to deviate from the stated accuracy rating, accuracy is governed by the formula: Accuracy = (zero stability / flow rate) x 100%. Repeatability is similarly affected by low flow conditions.

Model	lbm/min	kg/h
HPC015M/N/P/H	0.00088	0.024
HPC020M/N	0.0023149	0.063

## Pressures for sensor wetted components

Sensor	Maximum pressure
HPC015M	6,991 psi (482 bar)

Sensor	Maximum pressure
HPC015N	13,960 psi (963 bar)
HPC015P	15,374 psi (1,060 bar)
HPC015H	15,622 psi (1,077 bar)
HPC020M	12,168 psi (839 bar)
HPC020N	16,401 psi (1,131 bar)

HPC sensors comply with the high pressure piping requirements of ASME B31.3 Process Piping Code and the European Pressure Equipment Directive 2014/68/14 EU (PED).

### Maximum operating pressure for the sensor case

The maximum operating pressure is based on the included rupture disk.

Sensor	Rupture disk material and rating
HPC015M/N/P/H HPC020M/N	Disk material is 316L with a burst pressure of 63.8 psig (4.4 barg).

## Operating conditions: environmental

### HPC vibration limits

Meets IEC 60068-2-6, endurance sweep, 5 to 2000 Hz up to 1.0 g.

### Temperature limits

Model	Component	Limit
HPC015M/N/P/H HPC020M/N	Process fluid temperature	-50.8 °F (-46 °C) to 392 °F (200 °C)
	Ambient temperature	-40 °F (-40.0 °C) to 140 °F (60 °C)

#### Notes

- In all cases, the electronics cannot be operated where the ambient temperature is below -40 °F (-40.0 °C) or above 140 °F (60.0 °C). If a sensor is to be used where the ambient temperature is outside of the range permissible for the electronics, the electronics must be remotely located where the ambient temperature is within the permissible range, as indicated by the shaded area of the temperature limit graphs.
- Temperature limits may be further restricted by hazardous area approvals. Refer to the hazardous area approvals documentation shipped with the sensor or available from [Emerson.com](http://Emerson.com).

## Operating conditions: process

### Process temperature effect

- For mass flow measurement, process temperature effect is defined as the change in sensor flow accuracy due to process temperature change away from the calibration temperature. Temperature effect on flow can be corrected by zeroing at normal operating temperature. Use the Zero Verification tool to optimize the zero calibration.
- For density measurement, process temperature effect is defined as the change in sensor density accuracy due to process temperature change away from the calibration temperature.

Model	Mass flow	Density	
	% of maximum mass flow rate per °C	g/cm <sup>3</sup> per °C	kg/m <sup>3</sup> per °C
HPC015M/N/P	±0.0009	±0.0034	±3.0
HPC015H	±0.00175	±0.0034	±3.0
HPC020M/N	±0.002	±0.0034	±3.0

### Process pressure effect

Process pressure effect is defined as the change in sensor mass flow and density accuracy specification due to process pressure change away from the calibration pressure. This effect can be corrected by dynamic pressure input or a fixed meter factor. See the calibration sheet for the specific meter pressure compensation coefficient. If no pressure compensation coefficient is provided, use the typical values listed in the table below. For proper setup and configuration, see the transmitter's configuration and use manual at [Emerson.com/flowmeasurement](http://Emerson.com/flowmeasurement).

Component	Specification
Mass flow accuracy	No effect up to maximum pressure rating
Density accuracy	HPC015: 0.000001 g/cm <sup>3</sup> per psi (0.001 kg/m <sup>3</sup> per bar)

### Pressure relief

The HPC sensors have a rupture disk installed on the case as a standard option. Rupture disks are meant to vent process fluid from the sensor case in the unlikely event of a flow tube breach. Some users connect a pipeline to the rupture disk to help contain escaping process fluid. If the rupture disk is activated by a tube breach, the seal in the rupture disk will be broken, and the Coriolis meter should be removed from service.

Figure 1: Rupture disk on the HPC015



A. Rupture disk

**! WARNING**

Personnel must stay clear of the rupture disk pressure relief area. High-pressure fluid escaping from the sensor can cause severe injury or death.

HPC sensors are available without a rupture disk if required. For details, contact Micro Motion.

## Hazardous area classifications

### Approvals and certifications

Type	Approval or certification	
CSA and CSA C-US	Class I, Div. 1, Groups A, B, C, and D Class I, Div. 2, Groups A, B, C, and D Class II, Div. 1, Groups E, F, and G Dual Seal	
ATEX Zone 1 <sup>(1)</sup>		II 2 G Ex ib IIC T6/T5/T4...T1 Gb II 2 D Ex ib IIIC T* °C Db IP66/IP67 <sup>(1)</sup>
ATEX Zone 2 <sup>(1)</sup>		II 3 G Ex nA IIC T5/T4...T1 Gc II 3 D Ex tc IIIC T* °C Dc IP66/IP67 <sup>(1)</sup> >
IECEX Zone 1 <sup>(1)</sup>	Ex ib IIC T6/T5/T4...T1 Gb Ex ib IIIC T* °C Db IP66/IP67 <sup>(1)</sup> >	
IECEX Zone 2 <sup>(1)</sup>	Ex nA IIC T5/T4...T1 Gc Ex tc IIIC T* °C Dc IP66/IP 67 <sup>(1)</sup> >	
Ingress Protection Rating	IP 66/67 for sensors and transmitters	
NEPSI Zone 1	Ex ib IIB + H <sub>2</sub> /IIC T1~T6 Gb Ex ibD 21 T80~T163.7	
NEPSI Zone 2	Ex nA IIC T1~T5 Gc Ex tD A22 IP66/IP67 T95 °C~T163.7 °C	
EMC effects	Complies with EMC directive 2014/30/EU per EN 61326 Industrial	
NAMUR	Complies with NAMUR NE 021 (09.05.2012)	

(1) Dust approval available only upon request.

**Note**

- Approvals shown are for HPC sensors configured with 2200, 2400, and 5700 transmitters. Sensors with integral electronics may have more restrictive approvals. Refer to the Product Data Sheet for each transmitter for details.
- When a sensor is ordered with hazardous area approvals, detailed information is shipped along with the product.
- More information about hazardous approvals, including detailed specifications and temperature graphs for all sensor configurations is available at [Emerson.com](http://Emerson.com).

**Industry standards**

Type	Standard
Pressure vessel standards	<ul style="list-style-type: none"> <li>■ Pressure Equipment Directive (PED) 2014/68/EU</li> <li>■ Product complies with the high-pressure piping requirements of ASME B31.3, Chapter IX.</li> </ul>
Weights & Measures for custody transfer applications	OIML R139-1

## Connectivity

HPC sensors are highly customizable to provide a configuration that is tailor-fit to specific applications. For help determining which Micro Motion products are right for your application, see the resources at [Emerson.com](http://Emerson.com).

## Communication and diagnostic information

Transmitter interface	Diagnostic data
<ul style="list-style-type: none"> <li>■ Up to five fully configurable I/O channels, with options for 2-wire, Ethernet, and wireless communication</li> <li>■ Complete suite of mounting options to accommodate installation requirements — integral, remote, wall mount, and DIN rail</li> <li>■ Application software designed specific for your process — batching, concentration, and Advanced Phase Measurement</li> </ul>	<ul style="list-style-type: none"> <li>■ Smart Meter Verification — checks the health and integrity of the meter’s tubes, electronics, and calibration without interrupting the process</li> <li>■ Zero verification — quickly diagnoses the meter to determine if re-zeroing is recommended, and if process conditions are stable and optimal for zeroing</li> <li>■ Multiphase detection — proactively identifies multiphase process conditions and severity</li> <li>■ Time-stamped digital audit trails and reports for optimized agency compliance</li> </ul>









## Communication protocols

Typical I/O connectivity options include:

- 4-20 mA
- HART®/ *Wireless*HART®
- 10k Hz pulse
- Wi-Fi
- EtherNet/IP™
- Modbus® TCP
- Modbus RTU
- Modbus ASCII
- FOUNDATION™ Fieldbus
- PROFINET®
- PROFIBUS®-PA
- PROFIBUS-DP
- Discrete I/O

## Transmitter compatibility and primary attributes

For a complete list of all transmitter configurations and options, see the transmitter product data sheets and other resources available at [Emerson.com](http://Emerson.com).

Model	Transmitter						
	5700	4700	4200	1700/2700	1500/2500	2400S	3500 / 3700
							
<b>Mounting options</b>							
Field mount	•	•	•	•		•	•
Rack/panel mount					•		•
<b>Power</b>							
AC	•	•		•		•	•
DC	•	•		•	•	•	•
Loop powered (2-wire)			•				
<b>Diagnostics</b>							
Smart Meter Verification (SMV) basic (Included)	•	•	•	•	•	•	•
SMV Pro	•	•	•	•	•	•	•
Real time clock	•	•	•				
Onboard data historian	•	•	•				
<b>Local operator interface</b>							
2-line display				•		•	
Graphical display	•	•	•				•
<b>Certifications and approvals</b>							
SIS certified	•	•	•	•			
Custody transfer	•	•		•			•

## Physical specifications

### Materials of construction

General corrosion guidelines do not account for cyclical stress, and therefore should not be relied upon when choosing a wetted material for your Micro Motion meter. For material compatibility information, see the [Micro Motion Corrosion Guide](#).

**Wetted path materials**

Model	Material options		Sensor weight
	XM-19 & 316/L stainless steel	Nickel alloy C22	
HPC015M/N/P	•		13 lb (5.9 kg)
HPC015H		•	13 lb (5.9 kg)
HPC020M/N	•		13 lb (5.9 kg)

**Non-wetted part material options**

Component	Enclosure rating	316L/CF-3M stainless steel	304 stainless steel
HPC015M/N/P/H	NEMA 4X (IP66/67)	•	•
Core processor housing	NEMA 4X (IP66/67)	•	
Junction box housing	IP66/67	•	
2200 transmitter housing	NEMA 4X (IP66/67)	•	
2400 transmitter housing	NEMA 4X (IP66/67)	•	
4200 transmitter housing	NEMA 4X (IP66/67)		
5700 transmitter housing	NEMA 4X (IP66/67)		

**Note**

- Weight specifications are based upon 9/16-in. (15 mm) autoclave connections.

**Process connections**

HPC Series sensor fittings are 9/16 inch (15 mm) female, medium pressure cone and threaded. A 3/8 inch adapter to the 9/16 inch cone; threaded connection is also available for purchase. Contact your local sales team representative for information on gland and collar configuration options best suited to your application needs. For more process connection options, please contact the factory.

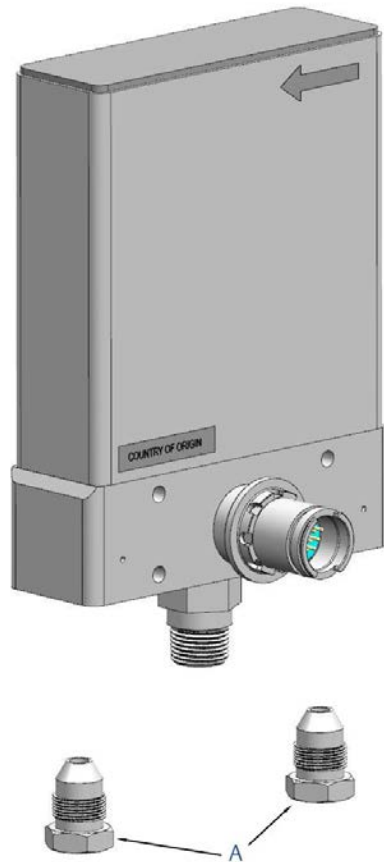

A. 9/16-in. to 3/8-in. adapters

## Dimensions

Complete and detailed dimensional drawings can be found at the [Sizing and Selection](#) tool.

### Note

- Dimensions  $\pm 0.118$  in. ( $\pm 3.00$  mm) apply only to face to face - other dimensions are nominal
- Representative of a sensor fitted with 9/16-in. (15 mm) medium pressure autoclave compatible fittings
- These dimensions apply to only one electronic interface option — others are available

**HPC dimensions**

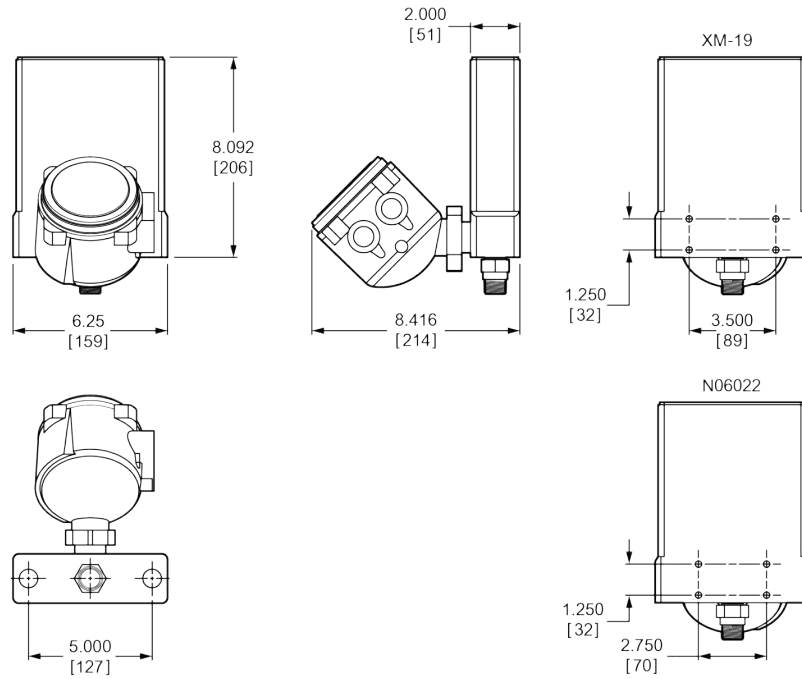

Dimensions are in inches [mm].

**HPC mounting bracket dimensions**

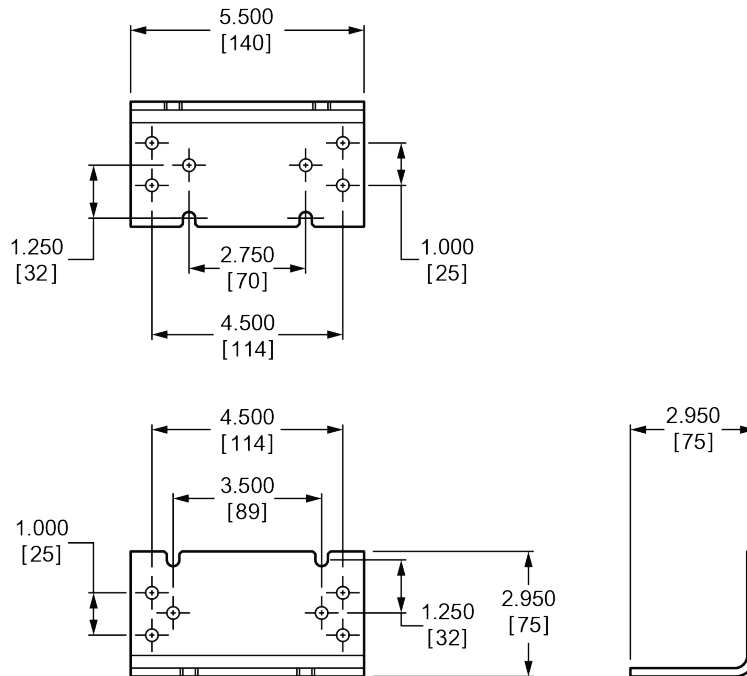

Dimensions are in inches [mm].

**Flow tube information**

Model	No. of tubes	Tube inside diameter (in)	Tube inside diameter (m)	Tube length (in)	Tube length (m)
HPC015M	2	0.091	0.0023	14.2	0.361
HPC015N	2	0.091	0.0023	14.2	0.361
HPC015P	2	0.091	0.0023	14.2	0.361
HPC015H	2	0.087	0.0023	14.2	0.361
HPC020M	2	0.15	0.0038	13.5	0.344
HPC020N	2	0.14	0.0035	13.5	0.344

## Ordering information

This section lists the available options and ordering codes for the HPC product family.

### Sensor base model

Code	Case option
HPC015M	Micro Motion High-Pressure Coriolis Meter, 1/8-in. (DN2) XM-19 stainless steel, 6,991 psi (482 bar) maximum operating pressure
HPC015N	Micro Motion High-Pressure Coriolis Meter, 1/8-in. (DN2) XM-19 stainless steel, 13,960 psi (963 bar) maximum operating pressure
HPC015P	Micro Motion High-Pressure Coriolis Meter, 1/8-in. (DN2) XM-19 stainless steel, 15,375 psi (1060 bar) maximum operating pressure
HPC015H	Micro Motion High-Pressure Coriolis Meter, 1/8-in. (DN2) nickel alloy (N06022), 15,622 psi (1,077 bar) maximum operating pressure
HPC020M	Micro Motion High-Pressure Coriolis Meter, 1/8-in. (DN3) XM-19 stainless steel, 12,168 psi (839 bar) maximum operating pressure
HPC020N	Micro Motion High-Pressure Coriolis Meter, 1/8-in. (DN3) XM-19 stainless steel, 16,401 psi (1,131 bar) maximum operating pressure

### Process connections

Code	Description
C60	Two 9/16-in. (15mm) 316/316L stainless steel Medium Pressure (MP) cone and thread female autoclave compatible fittings (Glands and collars not provided)
E39	Two 9/16-in. (15mm) 316/316L stainless steel Medium Pressure (MP) cone and thread female autoclave compatible fittings (Glands and collars not provided)
E47	Two 9/16-in. (15mm) nickel alloy (N06022) Medium Pressure (MP) cone and thread female autoclave compatible fittings with nickel alloy (N10276) adapters to 3/8-in. (10mm) MP cone and thread autoclave compatible fittings (Glands and collars included)
E48	Two 9/16-in. (15 mm) 316/316L Medium Pressure (MP) cone and thread female autoclave compatible fittings with 316 adapters to 3/8-in. (10 mm) MP cone and thread autoclave compatible fittings (Glands and collars included)

Code	Description
999	ETO process connection Requires the X Factory option.

## Case options

Code	Case option
D	304L stainless steel case with rupture disk
R	316L stainless steel case with rupture disk

## Electronics interface

Code	Electronics interface
0	Integral mount 2400S transmitter
1	Extended integral mount 2400S transmitter
2	4-wire polyurethane-painted aluminum integral enhanced core processor for remote mount transmitters
3	4-wire stainless steel integral enhanced core processor for remote mount transmitters
4	4-wire extended polyurethane-painted aluminum enhanced core processor for remote mount transmitters
5	4-wire extended stainless steel enhanced core processor for remote mount transmitters
6	MVD Solo; polyurethane-painted aluminum integral enhanced core processor (for OEMs) When electronics interface 6, 7, 8, or 9 is ordered with approval A, P, Z, or I, the MVD Direct Connect I.S. barrier is supplied.
7	MVD Solo; stainless steel integral enhanced core processor (for OEMs) When electronics interface 6, 7, 8, or 9 is ordered with approval A, P, Z, or I, the MVD Direct Connect I.S. barrier is supplied.
8	MVD Solo; extended mount polyurethane-painted aluminum integral enhanced core processor (for OEMs) When electronics interface 6, 7, 8, or 9 is ordered with approval A, P, Z, or I, the MVD Direct Connect I.S. barrier is supplied.
9	MVD Solo; extended mount stainless steel enhanced core processor (for OEMs) When electronics interface 6, 7, 8, or 9 is ordered with approval A, P, Z, or I, the MVD Direct Connect I.S. barrier is supplied.
R	9-wire polyurethane-painted aluminum J-box
H	9-wire extended mount polyurethane-painted aluminum J-box
S	9-wire 316L stainless steel J-box
T	9-wire extended mount 316L stainless steel J-box
Z	Requires a selection from <a href="#">Other electronic interfaces</a>

## Conduit connections

Code	Conduit connection
<b>Electronics interface codes 0, 1, F, J, U, Z (UA)</b>	
A	No gland

Code	Conduit connection
<b>Electronics interface codes 2, 3, 4, 5, 6, 7, 8, 9</b>	
B	½ in. NPT — no gland
E	M20 — no gland
F	Brass/nickel cable gland - cable diameter 0.335 in. (8.5 mm) to 0.394 in. (10.0 mm)
G	Stainless steel cable gland - cable diameter 0.335 in. (8.5 mm) to 0.394 in. (10.0 mm)
<b>Electronics interface codes R, H, S, T</b>	
A	¾ in. NPT - no gland
H	Brass nickel cable gland
J	Stainless steel cable gland

## Approvals

### Electronics interface codes 0, 1

Code	Approval
M	Micro Motion Standard (no approval, without CE/EAC markings)
N	Micro Motion Standard / PED compliant (with CE/EAC markings)
2	CSA (US and Canada): Class I, Div.2
V	ATEX - Equipment Category 3 (Zone 2) / PED compliant
3	IECEX Zone 2
4	NEPSI Zone 2 Available only with the Chinese (M) language.
G	Country Specific Approval – Requires a selection from the Approvals section of the <a href="#">Certificates, tests, calibrations, and services</a> model code options.

### Electronics interface code F, J, U

Code	Approval
M	Micro Motion Standard (no approval, without CE/EAC markings)
N	Micro Motion Standard / PED compliant (with CE/EAC markings)
A	CSA (US and Canada): Class I, Div. 1
Z	ATEX - Equipment Category 2 (Zone 1)
I	IECEX Zone 1
P	NEPSI Available only with the Chinese (M) language.
2	CSA (US and Canada): Class I, Division 2, Groups A, B, C, D
V	ATEX - Equipment Category 3 (Zone 2)
3	IECEX Zone 2
4	NEPSI Zone 2 Available only with the Chinese (M) language.
G	Country Specific Approval – Requires a selection from the Approvals section of the <a href="#">Certificates, tests, calibrations, and services</a> model code options.

**Electronics interface codes 2, 3, 4, 5, R, H, S, T**

Code	Approval
M	Micro Motion Standard (no approval, without CE/EAC markings)
N	Micro Motion Standard / PED compliant (with CE/EAC markings)
A	CSA (US and Canada): Class I, Div. 1
2	CSA (US and Canada): Class I, Div. 2
Z	ATEX - Equipment Category 2 (Zone 1) / PED compliant
I	IECEX Zone 1
P	NEPSI Available only with the Chinese (M) language.
G	Country Specific Approval – Requires a selection from the Approvals section of the <a href="#">Certificates, tests, calibrations, and services</a> model code options.

**Electronics interface codes 6, 7, 8, 9 (MVDSolo or MVDSolo with MVD Direct Connect I.S. Barrier)**

Code	Approval
M	Micro Motion Standard (no approval, no barrier included, without CE/EAC markings)
N	Micro Motion Standard / PED compliant (no approval, no barrier included, with CE/EAC markings)
A	CSA (US and Canada): Class I, Div. 1
Z	ATEX - Equipment Category 2 (Zone 1) / PED compliant
I	IECEX Zone 1
P	NEPSI Zone 1 Available only with the Chinese (M) language.
G	Country Specific Approval – Requires a selection from the Approvals section of the <a href="#">Certificates, tests, calibrations, and services</a> model code options.

## Languages

**Languages**

The transmitter language is available only in English.

Code	Language option
A	Danish CE requirements document and English installation manual
C	Czech installation manual
D	Dutch CE requirements document and English installation manual
E	English installation manual
F	French installation manual
G	German installation manual
H	Finnish CE requirements document and English installation manual
I	Italian installation manual
J	Japanese installation manual
M	Chinese installation manual
N	Norwegian CE requirements document and English installation manual

Code	Language option
O	Polish installation manual
P	Portuguese installation manual
Q	Korean installation manual
R	Russian installation manual
S	Spanish installation manual
W	Swedish CE requirements document and English installation manual
B	Hungarian CE requirements document and English installation manual
K	Slovak CE requirements document and English installation manual
T	Estonian CE requirements document and English installation manual
U	Greek CE requirements document and English installation manual
L	Latvian CE requirements document and English installation manual
V	Lithuanian CE requirements document and English installation manual
Y	Slovenian CE requirements document and English installation manual

## Future option 1

Code	Future option 1
Z	Future option

## Calibration options

Code	Calibration option
Z	HPC015: $\pm 0.20\%$ mass flow and $\pm 1 \text{ kg/m}^3$ ( $\pm 0.001 \text{ g/cm}^3$ ) density calibration ( $\pm 0.20\%$ volume flow)
1	HPC015: $\pm 0.10\%$ mass flow and $\pm 1 \text{ kg/m}^3$ ( $\pm 0.001 \text{ g/cm}^3$ ) density calibration ( $\pm 0.15\%$ volume flow)

## Measurement application software

Code	Measurement application software
Z	No measurement application software
A <sup>(1)</sup>	Petroleum measurement

(1) Available with electronics interface codes 6, 7, 8 and 9. For all other electronics interface codes, select the petroleum measurement software option on the transmitter.

## Factory options

Code	Description
Z	Standard product
X	Engineer to order (ETO) product

Code	Description
R	Restocked product (if available)

## Certificates, tests, calibrations, and services

All of the codes in the following tables are optional. Select multiple add on options as needed.

### Note

There may be additional options or limitations depending on total meter configuration. Contact a sales representative before making your final selections.

### Material quality examination tests and certificates

Select as many codes from this table as required.

Code	Factory option
MC	Material inspection certificate 3.1 (supplier lot traceability per EN 10204)
NC	NACE certificate 2.1 (MR0175 and MR0103)
NS	Certificate of Compliance Certificate 2.1 to NORSOK requirements for material, fabrication, examination, and testing

### Radiographic testing

Select only one code from this table.

Code	Factory option
RE	X-ray package 3.1 (radiographic examination certificate; weld map; radiographic inspection NDE qualification)
RT	X-ray package 3.1 (radiographic examination certificate with digital image; weld map; radiographic inspection NDE qualification)

### Pressure testing

Select as many codes from this table as required.

Code	Factory option
HT	Hydrostatic Test Certificate 3.1
HE	Helium Leak Test Certificate 3.1 (wetted components only)

### Dye penetrant examination

Code	Factory option
D1	Dye Penetrant Test Package 3.1 (Sensor only; Liquid Dye Penetration NDE Qualification)

### Weld examination

Code	Factory option
WP	Weld procedure package (weld map, weld procedure specification, weld procedure qualification record, welder performance qualification)

### Positive material testing

Select only one code from this table.

Code	Factory option
PM	Positive Material Test Certificate 3.1 (without carbon content)
PC	Positive Material Test Certificate 3.1 (including carbon content)

### Special cleaning

Code	Factory option
O2	Declaration of Compliance Oxygen Service 2.1

### Accredited calibration

Code	Factory option
IC	ISO17025 Accredited Calibration and Certificates (9 points total)

### Special calibration options

Select either none, CV, or CV with one of the additional verification point options.

Code	Factory option
CV	Custom verification (alter original verification points)
01	Add one additional verification point
02	Add two additional verification points
03	Add three additional verification points
06	Add up to six additional verification points
08	Add up to eight additional verification points
16	Add up to sixteen additional verification points

### Sensor completion options

Select as many codes from this table as required.

Code	Factory option
WG	Witness General
SP	Special Packaging

### Mounting bracket

Code	Factory option
MB	Mounting bracket with hardware kit for HPC sensors.

### Instrument tagging

Code	Factory option
TG	Instrument tagging - customer information required (maximum 24 characters)

### Other electronic interfaces

Select only one of the following codes if you have selected electronic interface option Z (see [Electronics interface](#)).

<b>Code</b>	<b>Factory option</b>
UA	4200 integral mount aluminum housing



For more information: [Emerson.com/global](https://emerson.com/global)

©2025 Micro Motion, Inc. All rights reserved.

The Emerson logo is a trademark and service mark of Emerson Electric Co. Micro Motion, ELITE, ProLink, MVD and MVD Direct Connect marks are marks of one of the Emerson Automation Solutions family of companies. All other marks are property of their respective owners.