

Rosemount™ 3418 8-Path Gas Ultrasonic Flow Meter

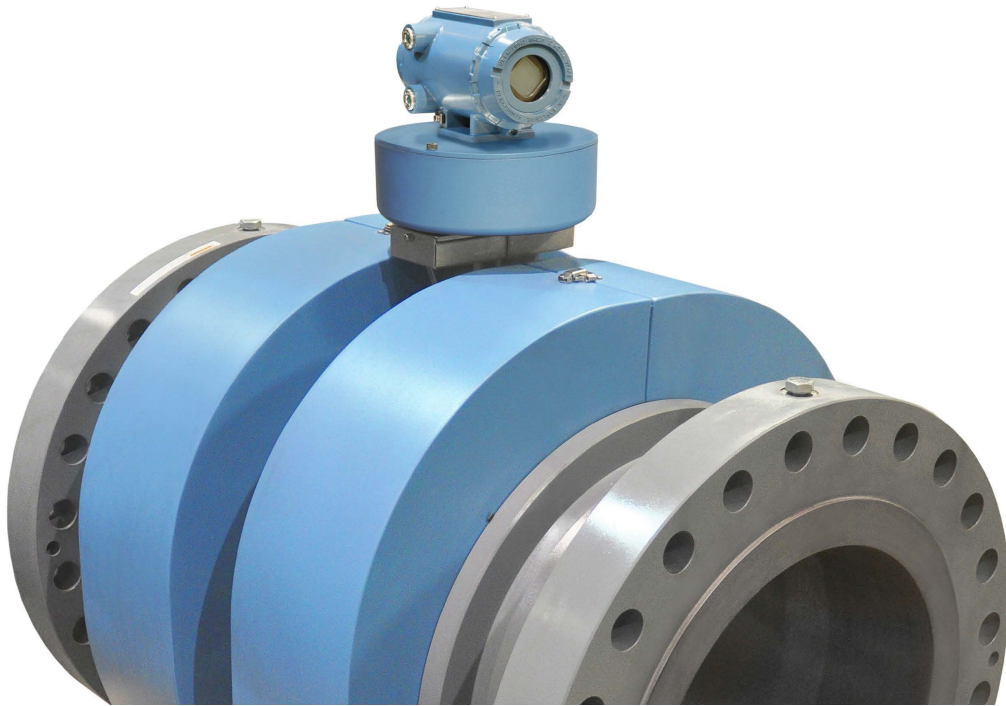

Rosemount 3418 Gas Ultrasonic Flow Meter

Highest accuracy for custody transfer

The Rosemount 3418 is an 8-path gas ultrasonic meter designed for natural gas custody transfer applications where high accuracy and long-term reliable performance is critical as it is in large volume transfers and in compact installations.

This 8-path chordal meter has eight paths in four locations placed in opposition to each other, allowing the meter to cancel out asymmetrical velocity effects. The meter provides higher resolution of the flow and can more accurately calculate swirl; therefore, it easily compensates for non-ideal flow distortions that result from pipe bends, shorter straight runs or smaller design footprints. Consequently, the need for flow conditioning elements and long upstream piping configurations is reduced, minimizing the footprint and the cost of the installation.

With 16 transducer modules forming eight chordal paths, the Rosemount 3418 has one transmitter—and averages fluid velocity measurements from all eight chordal paths to calculate total flow. The transmitter performs all control and timing for the generation and measurement of acoustic pulses. Acoustic processing is performed by specialized proprietary 3410 electronics that are designed to achieve high sampling rates, provide stable ultrasonic signals and optimal low flow response.

Available in DN250 to DN1050 (10–42 inches), the Rosemount 3418 offers bidirectional flow capabilities, increased flow capacity and no incremental pressure drop, therefore reducing measurement risk and minimizing operating cost.

The Rosemount 3418 Gas Ultrasonic Flow Meter is designed to reduce uncertainty by reducing shift due to installation effects. It has OIML accuracy class 0.5 and requires only five diameters of straight run and no flow conditioner. To further improve measurement confidence, the meter is equipped to process speed of sound calculations in real time and compare theoretical values with actual values using AGA 10 or GERG 2008 methods. The meter will use real-time gas composition data and pressure and temperature data using direct inputs. Its performance, on-board intelligence and accuracy are unsurpassed.

Figure 1: Based on a Patented, Interlocked British Gas Path Layout, Eight Direct Paths Are Integrated into One Measurement for Swirl Immunity and Ultra-high Accuracy Measurement



Typical applications

- Custody transfer for natural gas transmission lines

Application sites

- Power plants – inlets
- Gas processing plants – inlets/outlets
- Underground storage sites – inlets/outlets
- Gas production – onshore/offshore
- City gate stations – receipt/delivery points

Features and benefits

- OIML Accuracy Class 0.5 with five diameters upstream pipe and no flow conditioner
- Best-in-class performance in compact installations
- Reduce size, weight and capital costs of metering system designs
- No flow conditioner reduces compression and pumping costs and eliminates maintenance due to blockages
- High rangeability of >100:1 ensures fewer meter runs, smaller line sizes and lower capital costs
- Equipped [with robust titanium encapsulated T-200 Transducers for optimal performance in wet and corrosive environments standard for line sizes up to DN900 (36-inch) and optional for DN1050 (42-inch)]
- T-200 Transducers are safely extractable under pressure without special tools and its non-wetted design eliminates possibility of greenhouse gas emissions.
- 3410 Series Electronics provide fast sampling, an expandable electronics platform and an archive data log containing pressure, temperature and gas composition information which allows the meter to calculate standard condition flow rates like a redundant flow computer.
- 3410 Series Electronics calculate corrected volume rates, mass rates and energy rates.
- 3410 Series Electronics calculate speed of sound from pressure, temperature and gas composition using AGA 10 2003 and GERG-2008 (AGA 8 Part 2, 2017).
- Local LED display (optional) with up to ten user-selectable scrolling variables
- The Rosemount 3418 Gas Ultrasonic Flow Meter is now available with Smart Meter Verification, giving users access to expert flow analysis and providing a simplified and intuitive overall measurement status result minimizing time spent analyzing data. This new feature can be accessed through Modbus® or MeterLink™ Diagnostic Software.
- Predictive diagnostics allow plant personnel to quickly detect and respond to abnormal situations to avoid process upsets and unscheduled downtime.

Access information when you need it with asset tags

Newly shipped devices include a unique QR code asset tag that enables you to access serialized information directly from the device. With this capability, you can:

- Access device drawings, diagrams, technical documentation, and troubleshooting information in your MyEmerson account.
- Improve mean time to repair and maintain efficiency.
- Ensure confidence that you have located the correct device.
- Eliminate the time-consuming process of locating and transcribing nameplates to view asset information.

Standard specifications

If requirements are outside of the listed specifications, consult an Emerson Ultrasonics product specialist. Depending on the application, other product and material offerings may be available.

Meter specifications

Characteristics

- 8-path (sixteen transducers) chordal design

Meter performance

- Flow calibrated accuracy is $\pm 0.1\%$ of reading over entire flow calibration range
- OIML Accuracy Class 0.5 with 5 diameters upstream pipe and no flow conditioner
- Repeatability is $\pm 0.05\%$ of reading for 5 to 100 ft/s (1.5 to 30.5 m/s)

Velocity range

- Nominal 1.7 to 100 ft/s (0.5 to 30 m/s) with over-range performance exceeding 125 ft/s (38 m/s) on some sizes
- Meter meets or exceeds AGA 9 2017 3rd Edition / ISO 17089 performance specifications

Table 1: AGA 9 / ISO 17089 Flow rate values (US Customary units)

Meter size (in.)	10 to 24	30	36	42
q_{\min} (ft/s)	1.7	1.7	1.7	1.7
q_t (ft/s)	10	8.5	7.5	CF
q_{\max} (ft/s)	100	85	75	CF

Table 2: AGA 9 / ISO 17089 Flow rate values (Metric units)

Meter size (DN)	250 to 600	750	900	1050
q_{\min} (m/s)	0.5	0.5	0.5	0.5
q_t (m/s)	3.048	2.591	2.29	CF
q_{\max} (m/s)	30.48	25.91	22.86	CF

Electronics performance

Power

- 10.4 Vdc to 36 Vdc
- 8 watts typical; 15 watts maximum

Mechanical ratings

Line sizes

- 10-42 in. (DN250 to DN1050)⁽¹⁾
- All meters use a patented interlocked Dual-British Gas (BG) layout.

Operating gas temperature (transducers)

- T-200⁽²⁾: -58°F to +257°F (-50°C to +125°C)
- T-21: -4°F to +212°F (-20°C to +100°C)
- T-41: -58°F to +212°F (-50°C to +100°C)
- T-22: -58°F to +212°F (-50°C to +100°C)

Operating pressure range (transducers)

- T-200⁽²⁾: 15-3,750 psig (1.03-258.55 bar)
- T-21/T-41/T-22: 100-4,000 psig (6.89-275.79 bar)
- T-21/T-41/T-22: 50 psig (3.45 bar) available with reduced Qmax⁽³⁾
- T-22: 0-3,750 psig (3.45-258.55 bar)⁽⁴⁾

Flanges

- Raised Face and Ring Type Joint (RTJ) for ANSI Classes 300-2,500 (PN 50-420)
- Compact flanges and hub end connectors (optional)

NACE, Norsok and PED compliance

- Designed for NACE[®] compliance⁽⁵⁾
- Norsok available upon request
- PED available upon request

Electronics ratings

Operating temperature

- With T-200 transducers: -40°F to +257°F (-40°C to +125°C)
- With T-21/T-22/T-41 transducers: -40°F to +212°F (-40°C to +100°C)

Operating relative humidity

- Up to 95% non-condensing

Storage temperature

- -40°F to +185°F (-40 °C to +85 °C) with a low temperature storage limit of -4°F (-20°C) for T-21 transducers and -58°F (-50°C) for T-41/T-22 transducers

Electronic housing options

- Integral mount (standard)

(1) Consult factory on meter sizes above 36 in. (DN900).

(2) Available for line sizes up to 42 inches. (DN1050) Consult factory for minimum operating pressures below 100 psig (6.89 bar).

(3) Refer to [US Customary units](#) for additional information pertaining to operation limits.

(4) For low pressure applications below 100 psig (6.89 bar), the meter must be equipped with isolated transducer mounts.

(5) It is the equipment user's responsibility to select the materials suitable for the intended services.

Materials of construction

The materials of construction are dependent upon application requirements that must be specified by the customer. If needed, an Emerson representative can provide material guidance.

Material specifications

Body and flange

Forgings

- ASTM A350 Gr LF2 Carbon Steel⁽⁶⁾
-50°F to +302°F (-46°C to +150°C)
- ASTM A350 Gr LF2 Carbon Steel⁽⁶⁾
-58°F to +302°F (-50°C to +150°C)
- ASTM A182 Gr F316/F316L Stainless Steel (Dual Certified)
-50°F to +302°F (-46°C to +150°C)
- ASTM A182 Gr F51 Duplex Stainless Steel⁽⁷⁾
-58°F to +302°F (-50°C to +150°C)
- ASTM A105 Carbon Steel
-20°F to +302°F (-29°C to +150°C)

Enclosure housing

- Standard: ASTM B26 Gr A356.0 T6 Aluminum
- Optional: ASTM A351 Gr CF8M Stainless Steel

Electronics bracket

Stainless Steel material

- 316 SS

Transducer components

Transducer mounts and holders o-rings

- Standard: Nitrile Butadiene Rubber (NBR)
- Other materials available

Transducer mounts and holders

- ASTM A564 Type 630 Stainless Steel Mounts
- ASTM A479 316L Stainless Steel Holders
- INCONEL[®] ASTM B446 (UNS N06625) Gr 1 Mount (optional)
- INCONEL ASTM B446 (UNS N06625) Gr 1 Holder (optional)

⁽⁶⁾ Impact tested per specified ASTM standard.

⁽⁷⁾ A995 4A material is not yet approved in Canada.

Paint specifications

Body and flange exterior

Carbon Steel body material

- Two coat paint; zinc primer and acrylic lacquer topcoat (standard)

Stainless Steel or Duplex body material

- Paint (optional)

Transducer shroud

Aluminum material

- Powder coated

Enclosure housing

Aluminum material

- 100% conversion coated and exterior coated with a polyurethane enamel

Stainless Steel material

- Passivated (optional)

Table 3: Body and flange maximum pressure ratings by construction materials [psi meter sizes 10-42 in.]. Pressure rating information is for -20°F to +100°F (-29°C to +38°C). Other temperatures may reduce the maximum pressure rating of the materials.

ANSI Class	Forged Carbon Steel	Forged 316/316L SS	Duplex SS
300	740	720	750
600	1,480	1,440	1,500
900	2,220	2,160	2,250
1500	3,705	3,600	3,750

Table 4: Body and flange maximum pressure ratings by construction materials [bar meter sizes DN250 to DN1050]. Pressure rating information is for -20°F to +100°F (-29°C to +38°C). Other temperatures may reduce the maximum pressure rating of the materials.

PN	Forged Carbon Steel	Forged 316/316L SS	Duplex SS
50	51.1	49.6	51.7
100	102.1	99.3	103.4
150	153.2	148.9	155.1
200	255.3	248.2	258.6
250	425.5	413.7	430.9

Flow meter sizing

US Customary units

[Table 5](#) and [Table 6](#) can be used to determine the flow range at reference conditions for all meter sizes. All calculations are based on Schedule 40 bore, +60 °F (15.6 °C) and typical gas composition (AGA 8 Amarillo). These values are intended to be a guide in sizing. Prior to order placement, confirm meter sizing with an Emerson Ultrasonics product specialist.

Calculating meter capacity

To calculate a volume rate for a given velocity, first find the capacity (flow rate) in [Table 5](#) or [Table 6](#) for the meter size and operating pressure. Next, multiply the capacity by the ratio of the desired velocity divided by 100 ft/s to obtain the desired volume rate.

The example below illustrates how to determine the hourly flow rate at 70 ft/s for an 10-inch meter operating at 800 psig:

$$\text{Flow rate} = 12,362 \text{ MSCFH} \quad \text{Velocity} = 70 \text{ ft/s} \quad \text{Answer} = \frac{12,362 \text{ MSCFH} \times 70 \text{ ft/s}}{100 \text{ ft/s}} = 8,653.4 \text{ MSCFH}$$

Table 5: Flow rates (MSCFH) based upon max rated velocity [10–24 in. = 100 ft/s][30 in. = 85 ft/s][36 in. = 75 ft/s]

Meter size (in.)	10	12	16	18	20	24	30	36	42	
Operating pressure (psig)	100	1,559	2,213	3,494	4,423	5,495	7,948	10,910	13,862	CF
	200	2,963	4,207	6,641	8,406	10,446	15,108	20,738	26,349	CF
	300	4,412	6,263	9,888	12,515	15,552	22,493	30,875	39,229	CF
	400	5,906	8,384	13,236	16,754	20,819	30,111	41,331	52,117	CF
	500	7,448	10,572	16,690	21,126	26,251	37,968	52,117	66,219	CF
	600	9,037	12,828	20,252	25,635	31,854	46,071	63,239	80,350	CF
	700	10,675	15,153	23,923	30,281	37,627	54,422	74,701	94,914	CF
	800	12,362	17,547	27,703	35,065	43,572	63,020	86,504	109,910	CF
	900	14,096	20,009	31,590	39,986	49,686	71,863	98,642	125,333	CF
	1000	15,877	22,537	35,581	45,038	55,964	80,943	111,105	141,169	CF
	1100	17,702	25,128	39,671	50,214	62,396	90,246	123,875	157,394	CF
	1200	19,567	27,774	43,850	55,504	68,969	99,752	136,923	173,973	CF
	1300	21,467	30,471	48,107	60,893	75,665	109,437	150,217	190,865	CF
	1400	23,395	33,208	52,428	66,362	82,462	119,267	163,711	208,009	CF
	1500	25,344	35,975	56,797	71,892	89,333	129,205	191,079	242,782	CF
	1600	27,306	38,760	61,193	77,456	96,247	139,205	191,079	242,782	CF
	1700	29,270	41,548	65,595	83,029	103,172	149,221	204,826	260,250	CF
	1800	31,227	44,326	69,981	88,580	110,069	159,197	218,520	277,649	CF
	1900	33,166	47,079	74,327	94,081	116,905	169,083	232,090	294,891	CF
	2000	35,079	49,793	78,612	99,505	123,645	178,832	245,472	311,894	CF

Table 6: Flow rates (MMSCFD) based upon max rated velocity [10–24 in. = 100 ft/s][30 in. = 85 ft/s][36 in. = 75 ft/s]

Meter size (in.)	10	12	16	18	20	24	30	36	42	
Operating pressure (psig)	100	37.4	53.1	83.9	106.1	131.9	190.8	261.8	332.7	CF
	200	71.1	101.0	159.4	201.8	250.7	362.6	497.7	632.4	CF
	300	105.9	150.3	237.3	300.4	373.2	539.8	741.0	941.5	CF
	400	141.8	201.2	317.7	402.1	499.6	722.7	991.9	1,260	CF
	500	178.7	253.7	400.6	507.0	630.0	911.2	1,250.8	1,589.3	CF
	600	216.9	307.9	486.1	615.2	764.5	1,105.7	1,517.7	1,928.4	CF
	700	256.2	363.7	574.2	726.7	903.1	1,306.1	1,792.8	2,277.9	CF
	800	296.7	421.1	664.9	841.6	1,045.7	1,512.5	2,076.1	2,637.8	CF
	900	338.3	480.2	758.2	959.7	1,192.5	1,724.7	2,367.4	3,008.0	CF
	1000	381.1	540.9	854.0	1,080.9	1,343.1	1,942.6	2,666.5	3,286.2	CF
	1100	424.8	603.1	952.1	1,205.1	1,497.5	2,165.9	2,973.0	3,777.5	CF
	1200	469.6	666.6	1,052.4	1,332.1	1,655.3	2,394.0	3,286.2	4,175.4	CF
	1300	515.2	731.3	1,154.6	1,461.4	1,816.0	2,626.5	3,605.2	4,580.7	CF
	1400	561.5	797.0	1,258.3	1,592.7	1,979.1	2,862.4	3,929.1	4,992.2	CF
	1500	608.3	863.4	1,363.1	1,725.4	2,144.0	3,100.9	4,585.9	5,826.8	CF
	1600	655.3	930.2	1,468.6	1,858.9	2,309.3	3,340.9	4,585.9	5,826.8	CF
	1700	702.5	997.2	1,574.3	1,992.7	2,476.1	3,581.3	4,915.8	6,246.0	CF
1800	749.5	1,063.8	1,679.5	2,125.9	2,641.7	3,820.7	5,244.5	6,663.6	CF	
1900	796.0	1,129.9	1,783.8	2,257.9	2,805.7	4,058.0	5,570.2	7,077.4	CF	
2000	841.9	1,195.0	1,886.7	2,388.1	2,967.5	4,292.0	5,891.3	7,485.5	CF	

Metric units

Table 7 and Table 8 can be used to determine the flow range at reference conditions for all meter sizes. All calculations are based on Schedule 40 bore, 15°C and typical gas composition (AGA 8 Amarillo). These values are intended to be a guide in sizing.

Calculating meter capacity

To calculate a volume rate for a given velocity, first find the capacity (flow rate) in Table 7 and Table 8 for the meter size and operating pressure. Next, multiply the capacity by the ratio of the desired velocity divided by 30.5 m/s to obtain the desired volume rate.

Example: Determine the hourly flow rate at 21 m/s for a DN250 meter operating at 4,500 kPag.

If Flow Rate = 280 MSCMH and Velocity = 21 m/s, the calculation is:

$$\frac{280 \text{ MSCMH} \times 21 \text{ m/s}}{30.5 \text{ m/s}} = 192.7 \text{ MSCMH}$$

Table 7: Flow rates (MSCMH) based upon max rated velocity [DN250 to DN600 = 30.5 m/s] [DN750 = 25.9 m/s] [DN900 = 22.9 m/s]

Meter size (DN)	250	300	400	500	600	750	900	1050	
Operating pressure (kPag)	1,000	62	88	139	218	315	432	550	CF
	1,500	91	129	204	320	463	635	809	CF
	2,000	121	171	270	425	615	843	1,074	CF
	2,500	151	214	339	533	770	1,056	1,345	CF
	3,000	182	259	408	642	929	1,274	1,622	CF
	3,500	214	304	480	754	1,091	1,496	1,905	CF
	4,000	247	350	553	869	1,257	1,724	2,195	CF
	4,500	280	397	627	987	1,427	1,957	2,491	CF
	5,000	314	446	704	1,107	1,600	2,195	2,794	CF
	5,500	349	495	781	1,229	1,778	2,438	3,104	CF
	6,000	384	545	861	1,354	1,959	2,686	3,420	CF
	6,500	420	597	942	1,482	2,143	2,939	3,742	CF
	7,000	457	649	1,025	1,612	2,331	3,460	4,405	CF
	7,500	495	702	1,109	1,744	2,523	3,460	4,405	CF
	8,000	533	757	1,195	1,879	2,718	3,727	4,745	CF
	8,500	572	812	1,281	2,015	2,915	3,997	5,090	CF
	9,000	611	867	1,369	2,154	3,115	4,272	5,439	CF
9,500	651	924	1,458	2,294	3,318	4,550	5,793	CF	
10,000	691	981	1,548	2,435	3,522	4,830	6,149	CF	

Table 8: Flow rates (MMSCMD) based upon max rated velocity [DN250 to DN600 = 30.5 m/s] [DN750 = 25.9 m/s] [DN900 = 22.9 m/s]

Meter size (DN)	250	300	400	500	600	750	900	1050	
Operating pressure (kPag)	1,000	1.484	2.106	3.325	5.229	7.563	10.372	13.205	CF
	1,500	2.182	3.097	4.889	7.690	11.122	15.251	19.418	CF
	2,000	2.895	4.110	6.489	10.206	14.761	20.242	25.773	CF
	2,500	3.626	5.147	8.126	12.780	18.485	25.348	32.273	CF
	3,000	4.373	6.207	9.800	15.414	22.293	30.571	38.923	CF
	3,500	5.137	7.292	11.512	18.107	26.189	35.914	45.725	CF
	4,000	5.919	8.401	13.264	20.862	30.174	41.378	52.682	CF
	4,500	6.718	9.536	15.055	23.679	34.248	46.964	59.795	CF
	5,000	7.535	10.695	16.885	26.558	38.412	52.674	67.065	CF
	5,500	8.369	11.880	18.755	29.499	42.665	58.508	74.492	CF
	6,000	9.221	13.089	20.664	32.502	47.009	64.463	82.075	CF
	6,500	10,090	14,322	22.612	35.565	51.439	70.538	89.810	CF
	7,000	10.975	15.579	24.596	38.686	55.953	76.729	97.692	CF
	7,500	11.877	16.859	26.616	41.863	60.549	83.031	105.716	CF
	8,000	12.793	18.160	28.670	45.094	65.221	89.438	113.873	CF
	8,500	13.723	19.480	30.754	48.372	69.962	95.940	122.151	CF
	9,000	14.666	20.818	32.866	51.694	74.766	102.528	130.539	CF
9,500	15.619	22.170	35.002	55.053	79.625	109.190	139.021	CF	
10,000	16.580	23.535	37.157	58.442	84.527	115.913	147.581	CF	

T-200 titanium encapsulated transducers

New non-wetted design

Designed for today's challenging application requirements, Ultrasonics T-200 Transducers are robustly designed for high performance in the harshest environments, such as process gases containing oil, wet gas, and corrosive chemicals.

The possibility of hydrocarbon corrosion is virtually eliminated due to the full metal, non-wetted design for increased longevity and stability. The T-200 design is also easy to use and maintain. The innovative transducer smart capsule, a single part, is retractable under pressure with no special tools, simplifying maintenance, minimizing downtime, and maximizing safety and convenience.

T-200 transducers are standard in flow meters sized DN250 to DN900 (10–36 in.) but may also be available in additional sizes upon request.

Figure 2: T-200 Transducer Assembly



Features and benefits

- Patented MiniHorn™ array technology mechanically amplifies the transducer signal, overcoming any signal attenuation or effects from reverberation.
- Non-wetted: Full metal encapsulated transducer located outside the process is impervious to liquid-borne dirt and corrosive fluids.
- Retrofittable: Easily upgrade existing flow meters equipped with T-11/T-12 or T-21/T-22 transducers.
- Long-term reliability: Isolated transducer design provides a barrier from corrosive hydrocarbon fluids and extends the life of transducer components.
- Extractable under pressure: The simplified smart capsule design is easily retractable without depressurizing the line and does not require a high-pressure extraction tool.
- Non-wetted design eliminates possibility of greenhouse gas emissions during extraction operations.
- Higher temperature rating: Allows for higher operating temperature and cleaning while inline.
- Extended warranty: three years standard.

Transducer specifications

Product compatibility

- Line sizes DN250 to DN1050 (10-42 in.)

Materials of construction

- Ti Gr12 housing/316/316L stainless steel stalk assembly (standard)
- Ti Gr12 housing/Inconel® stalk assembly (optional)

Fluid types

- Hydrocarbons, industrial gases

Fluid temperature

- -58 °F to +257 °F (-50 °C to +125 °C)

Operating pressure

- 15-3,750 psig (1.03-258.55 bar)

Operating frequency

- 125 kHz

Figure 3: Transducer Smart Capsule



Safety and compliance

Safety classifications

Underwriters Laboratories (UL/cUL)

- Hazardous Locations – Class 1, Division 1, Groups C and D

CE Marked Directives

- Explosive Atmospheres (ATEX)

International Electrotechnical Commission (IECEx)

Metrology approval

NMI/MID

- OIML R137 Class 0.5
- MID Class 1.0

Local LCD display

The Rosemount 3410 Series Electronics offer an optional local LCD display that uses three lines to indicate the variable name, variable value, and engineering units.

The local display configuration is supported via Rosemount MeterLink™ software or Emerson's AMS Trex Device with HART® interface protocol.

The local display shows up to ten items, which are user selectable from 26 variables. You can configure the display to scale volume units as actual or 000's, with an adjustable time base of seconds, hours, or days. The scroll rate can be adjusted from 1 to 100 seconds (default 5 seconds).

Figure 4: Local LCD Display



Table 9: User-Selectable Display Variables

Variables	Description
Volumetric Flow Rate	Uncorrected (actual) Corrected (standard or normal)
Average Flow Velocity	(No description necessary)
Average Speed of Sound	(No description necessary)
Pressure	Flowing, if utilized
Temperature	Flowing, if utilized
Frequency Output	<ul style="list-style-type: none"> ▪ 1A ▪ 1B ▪ 2A ▪ 2B
Frequency Output K-factor	Channel 1 or 2
Analog Output	1 or 2
Current Day's Volume Totals	Uncorrected or Corrected (forward or reverse)
Previous Day's Volume Totals	Uncorrected or Corrected (forward or reverse)
Total Volume Totals (non-reset)	Uncorrected or Corrected (forward or reverse)

Input/output

Table 10: CPU Module I/O connections (maximum wire gauge is 18 AWG)

	I/O Connection Type	Qty	Description
Serial communications	Serial RS232/RS485 Port	1	<ul style="list-style-type: none"> ■ Modbus® RTU/ASCII ■ 115 kbps baud rate ■ RS232/RS485 Full Duplex ■ RS485 Half Duplex
	Ethernet Port (TCP/IP) 100BaseT	1	<ul style="list-style-type: none"> ■ Modbus TCP
Digital input ⁽¹⁾	Contact Closure	1	<ul style="list-style-type: none"> ■ Status ■ Single polarity
Analog inputs ⁽²⁾	4-20 mA	2	<ul style="list-style-type: none"> ■ AI-1 Temperature⁽³⁾ ■ AI-2 Pressure⁽³⁾
Frequency/Digital outputs	TTL/Open Collector	6	<ul style="list-style-type: none"> ■ User Configurable (can configure Digital Input as 6th Frequency/Digital Output)
Analog output ⁽²⁾⁽⁴⁾	4-20 mA	1	<ul style="list-style-type: none"> ■ Independently configurable analog output

- (1) *The analog-to-digital conversion accuracy is within ±0.05% of full scale over the operating temperature range.*
- (2) *A 24 volt DC power supply is available to provide power to the sensors.*
- (3) *AI-1 and AI-2 are electronically isolated and operate in sink mode.*
- (4) *The analog output zero scale offset error is within ±0.1% of full scale and gain error is within ±0.2% of full scale. The total output drift is within ±50 ppm of full scale per °C.*

Table 11: Optional I/O Expansion Module

	I/O Connection Type	Qty	Description
Serial Communications	Serial RS232/RS485 Port	1	<ul style="list-style-type: none"> ■ Modbus RTU/ASCII ■ 115 kbps baud rate ■ RS232/RS485 Half Duplex
	Ethernet switch	3	<ul style="list-style-type: none"> ■ 100BaseT ■ Three Ports
Analog Input	4-20 mA	1	<ul style="list-style-type: none"> ■ Reserved for future use

Optional I/O Expansion Slot(s) by Enclosure Type: Standard Enclosure: 1 RS232/RS485 Half Duplex, 2-Wire OR 1 I/O Expansion Module Extended (Retrofit) Enclosure: 2 RS232/RS485 Half Duplex, 2-Wire OR 1 I/O Expansion Module and 1 RS232/RS485 Half Duplex, 2-Wire

Diagnostics and software

Significantly reduce time previously spent on data analysis and troubleshooting with the new SMART™ Meter Verification (SMV) feature now included in the latest meter firmware update.

Walk away with more confidence in your measurement with a clear measurement verification result as well as flow meter and process status results.

Every Ultrasonic Flow Meter works with advanced Rosemount MeterLink™ software to simplify monitoring and troubleshooting. This advanced software displays a number of performance-based diagnostics that indicate flow meter health. In addition, dynamic flow-based diagnostics help operators identify flow disturbances that may affect measurement uncertainty. Emerson has optimized the latest version of MeterLink to work with SMART Meter Verification, allowing for easy collection of monthly scheduled or on-demand SMV reports.

Figure 5: MeterLink Baseline Viewer

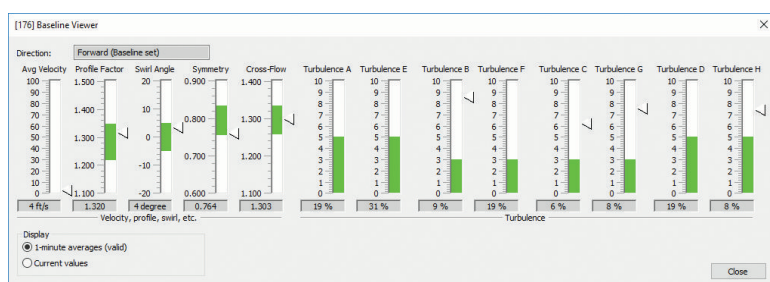
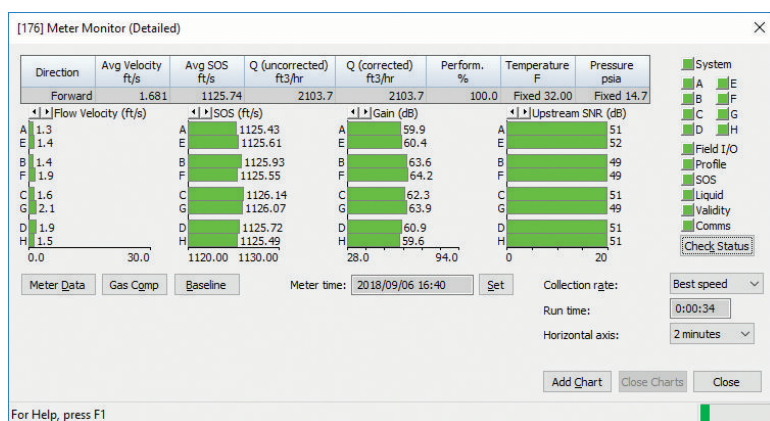

Figure 6: MeterLink Monitor Screen



- MeterLink software is available to download at no charge.
- MeterLink is required for transmitter configuration.
 - Flow meter also configurable with AMS Device Manager or TREX Device if HART® is used.
- MeterLink connects to flow meters using Ethernet (recommended), RS-232, or RS-485 full duplex
- Supports Microsoft® Windows® 7, 8.1, and 10
- Microsoft Office 2010-2019

Table 12: Features of Flow Meter, MeterLink, and Net Monitor⁽¹⁾

		Flow meter	Accessible through MeterLink	Accessible through Net Monitor
SMV	Scheduled or on-demand reports (PDF or XML)		•	•
	Clear measurement verification results	•	•	•

Table 12: Features of Flow Meter, MeterLink, and Net Monitor⁽¹⁾ (continued)

		Flow meter	Accessible through MeterLink	Accessible through Net Monitor
	Automatic report collection by meter group			•
	Last scheduled SMV result status multiple flow meter overview			•
	Bundle all scheduled flow meter reports		•	•
	Alarm prioritization	•	•	•
Operation	Configurable Modbus® Gas Chromatograph (GC) component data table	•		
	Speed of sound comparison ⁽²⁾	•	•	
	Transducer health monitoring	•	•	
	Baseline viewer		•	
	Monitor screen		•	
	Multiple charts with green limit bands		•	
	View waveforms		•	
	Speed of sound calculator ⁽²⁾		•	
	Help topics/troubleshooting guidance		•	
	Maintenance logs		•	
History	Hourly logs (180 days) and daily logs (five years)	•	•	
	Trend maintenance logs		•	
	Hourly/daily log graphing		•	
Configuration	Field Setup Wizard and Baseline Configuration Wizard		•	
	User name identified on audit log	•	•	
	Write protect switch	•		
	Compare configuration from logs		•	
	GC Master - Modbus serial/TCP	•		
	Modbus TCP slave	•		
Alarms	Alarm/audit/system logs	•	•	
	Bore buildup alarm	•	•	
	Blockage alarm	•	•	
	Abnormal profile alarm	•	•	
	Liquid detection alarm	•	•	
	Latched alarms	•	•	
	Severity alarm display		•	
	Reverse flow alarm	•	•	

(1) Net Monitor is an application automatically available with MeterLink that allows you to access and monitor all Ultrasonic Flow Meters that are part of a network.

(2) American Gas Association (AGA) 10 2003 and GERG-2008 (AGA 8 Part 2, 2017) supported.

(•) Feature is available.

Safety and compliance

The Rosemount 3418 Gas Ultrasonic Flow Meter meets worldwide industry standards for electrical and intrinsic safety certifications and approvals. For a complete list of agencies and certifications, consult an Emerson Ultrasonics technical specialist.

Safety classifications

Underwriters Laboratories (UL / cUL)

- Hazardous Locations — Class I, Division 1, Groups C, and D

CE Marked to Directives

- Explosive Atmospheres (ATEX)
- Certificate — Demko II ATEX 1006133X
- Marking —  II 2G Ex db ia IIB T4 Gb (-40°C ≤ T ≤ +60°C)
- Pressure Equipment Directive (PED)
- Electromagnetic Compatibility (EMC)

INMETRO

- Certificate — UL-BR 16.0144X
- Marking — Ex db ia IIB T4 Gb

International Electrotechnical Commission (IECEX)

- Marking — Ex db ia IIB T4 Gb

Canadian Registration Number

- Certificate — 0F14855

Figure 7: A Single Transducer Shroud Is Standard on DN250 to DN300 (10–12 inches) Rosemount 3418 meters



Environmental ratings

Aluminum

- NEMA® 4
- IP66 to EN60529

Stainless Steel

- NEMA 4X
- IP66 to EN60529

Metrology approval

OIML

- OIML R137-1&2 Edition 2012(E)
- Class 0.5

MID

- Directive 2014/32/EU (MID MI-002)
- Class 1.0

ISO 17089-1 : 2010 (E)

Figure 8: Dual Transducer Shrouds Are Standard on DN400 (16-inch) and larger Rosemount 3418 flow meters

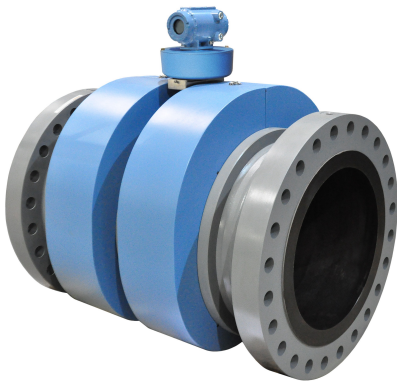

Operation limits

If requirements are outside of the operation limits shown below for T-21/T-41/T-22/T-200 transducers, consult an Emerson Ultrasonics product specialist.

Table 13: Recommended maximum velocity for 12 in. and smaller line size meters (US customary units)

Nominal meter size (in.)	Maximum velocity rating at 0 psig or greater (ft/s) ⁽¹⁾	Capacity at maximum rated velocity (ACFH) ⁽¹⁾	Schedule STD bore (in.)
10	100	197,136	10.020
12	100	282,743	12.000

(1) Isolated transducers mounts combined with T-22 transducers required for DN300 (12 in.) and smaller line size meters to achieve 0 to 689 kPag (0 to 100 psig). T-200 transducers minimum operating pressure varies by line size. Consult factory.

Table 14: Recommended maximum velocity for 16 in. and larger line size meters (US customary units)

Nominal Meter Size (in.)	Maximum velocity rating at 50 psig (ft/s)	Capacity between 50 to 100 psig (ACFH) ⁽¹⁾	Maximum velocity rating at 100 psig or greater (ft/s) at 100 psig (ft/s)	Capacity at max rated velocity (ACFH) ⁽¹⁾	Schedule STD bore (in.)
16	50	228,318	100	456,635	15.250
18	50	292,131	100	584,263	17.250
20	50	363,799	100	727,598	19.250
24	50	530,696	100	1,061,392	23.250
30	45	755,952	85	1,427,909	29.250
36	37.5	914,912	75	1,829,824	35.250
42	37.5	1,252,879	75	2,505,758	41.250

(1) Capacities are for meter ID equivalent to Schedule 40 (or STD).

Table 15: Recommended maximum velocity for DN300 and smaller line size meters (Metric units)

Nominal meter size (DN)	Maximum velocity rating at 0 kPag or greater (m/s) ⁽¹⁾	Capacity at maximum rated velocity (ACMH) ⁽¹⁾	Schedule STD bore (mm)
250	30.5	5,582	254.5
300	30.5	8,006	303.2

(1) Isolated transducers mounts combined with T-22 transducers required for DN300 (12 in.) and smaller line size meters to achieve 0–689 kPag (0–100 psig). T-200 transducers minimum operating pressure varies by line size. Consult factory.

Table 16: Recommended maximum velocity for DN400 and larger line size meters (Metric Units)

Nominal meter size (DN)	Maximum velocity rating at 345 kPag (m/s)	Capacity between 345 and 689 kPag (ACMH) ⁽¹⁾	Maximum velocity rating at 689 kPag or greater (m/s)	Capacity at maximum rated velocity (ACMH) ⁽¹⁾	Schedule STD bore (mm)
400	15.2	6,465	30.5	12,930	387.4
450	15.2	7,917	30.5	20,603	438.2
500	15.2	10,301	30.5	30,055	489
600	15.2	15,027	26	40,433	590.6
750	11.4	25,907	23	51,814	743
900	11.4	34,479	23	70,955	895.4

(1) Capacities are for meter ID equivalent to Schedule 40 (or STD).

Weights and dimensions

Figure 9: Dimension Key for DN200 to DN300 (8-12 inch) Meters with Single Transducer Shroud (See [Table 17](#) and [Table 18](#))

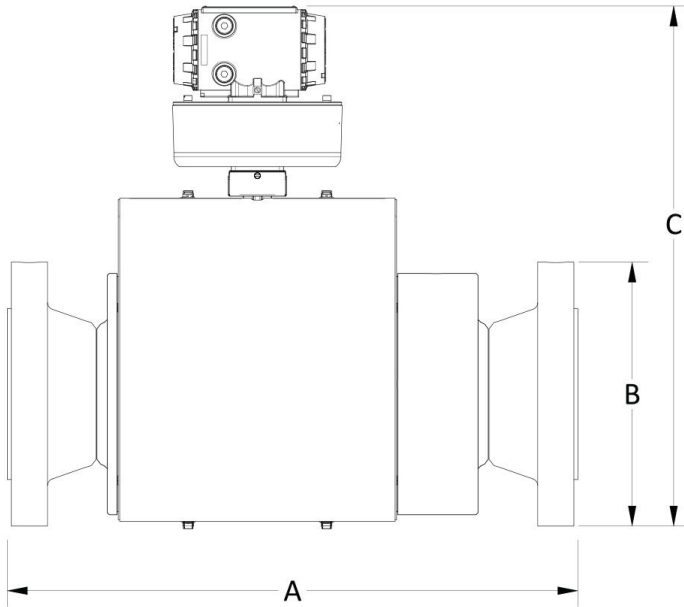
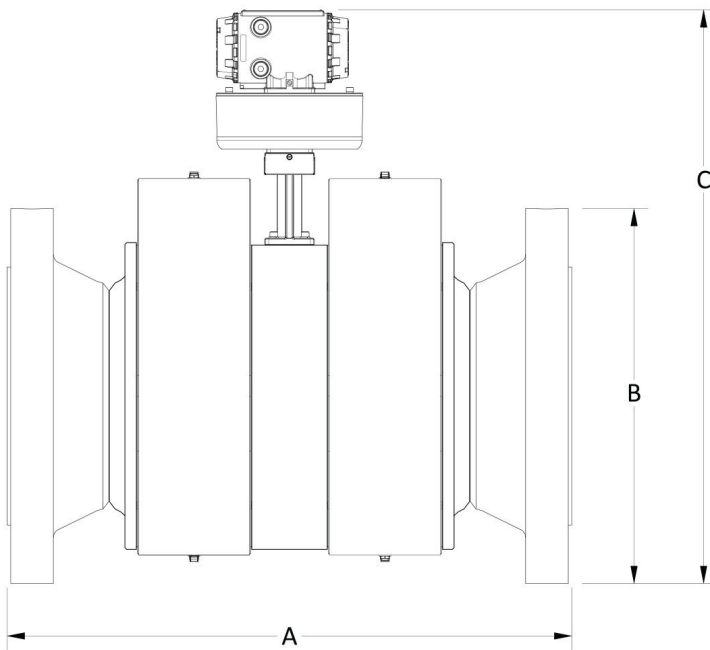

Figure 10: Dimension Key for DN400 and larger (16-inch and larger) Meters with Dual Transducer Shrouds (See [Table 17](#) and [Table 18](#))



Tables

The Meter Dimension Key diagrams ([Figure 9](#) and [Figure 10](#)) illustrate the meter component measurements that correspond to A, B and C in [Table 17](#) and [Table 18](#).

Note

All weights and dimensions based on standard electronics enclosure. The certified approval drawing will include the actual weights and dimensions.

Table 17: Weights and Dimensional Data (US Customary units) [Line sizes 10–28 inch, Port Angle 60°] [Line Sizes 30 inch and Larger, Port Angle 75°]

Nominal line size (in.)		10	12	16	20	24	30	36	42
300 ANSI	Weight (lb.)	1250	1550	2000	3100	4550	4950	6200	CF
	A (in.)	33.75	36.50	37.50	42.75	47.50	44.50	46.50	CF
	B (in.)	17.50	20.50	25.50	30.50	36.00	43.00	50.00	CF
	C (in.)	34.50	36.50	40.50	45.50	50.50	57.00	63.50	CF
600 ANSI	Weight (lb.)	1400	1750	2300	3450	5150	5650	7250	CF
	A (in.)	37.00	39.00	40.50	45.50	50.75	48.00	50.25	CF
	B (in.)	20.00	22.00	27.00	32.00	37.00	44.50	51.75	CF
	C (in.)	35.50	37.50	41.50	46.00	51.00	58.00	64.50	CF
900 ANSI	Weight (lb.)	1800	2500	3450	5000	8000	10200	15150	CF
	A (in.)	44.00	48.75	51.00	53.12	62.13	61.50	67.00	CF
	B (in.)	21.50	24.00	27.75	33.75	41.00	48.50	57.50	CF
	C (in.)	36.50	39.00	42.50	47.50	53.50	61.50	69.50	CF
1500 ANSI	Weight (lb.)	2250	3300	4950	7200	11200	CF	CF	CF
	A (in.)	49.75	55.75	59.00	62.00	71.50	CF	CF	CF
	B (in.)	23.00	26.50	32.50	38.75	46.00	CF	CF	CF
	C (in.)	37.00	40.00	45.00	50.00	56.00	CF	CF	CF

Table 18: Weights and Dimensional Data (Metric Units) [Line Sizes DN250 to DN700, Port Angle 60°] [Line Sizes DN750 and Larger, Port Angle 75°]

Nominal line size (DN)		250	300	400	500	600	750	900	1050
PN 50	Weight (kg)	567	703	907	1406	2064	2245	2812	CF
	A (mm)	857	927	953	1086	1207	1130	1181	CF
	B (mm)	445	521	648	775	914	1092	1270	CF
	C (mm)	876	927	1029	1156	1283	1448	1613	CF
PN 100	Weight (kg)	635	794	1043	1565	2336	2563	3289	CF
	A (mm)	940	991	1029	1156	1289	1219	1276	CF
	B (mm)	508	559	686	813	940	1130	1314	CF
	C (mm)	902	953	1054	1168	1295	1473	1638	CF
PN 150	Weight (kg)	816	1134	1565	2268	3629	4627	6872	CF
	A (mm)	1118	1238	1295	1349	1578	1562	1702	CF
	B (mm)	546	610	705	857	1041	1232	1461	CF
	C (mm)	927	991	1080	1207	1359	1562	1765	CF

Table 18: Weights and Dimensional Data (Metric Units) [Line Sizes DN250 to DN700, Port Angle 60°] [Line Sizes DN750 and Larger, Port Angle 75°] (continued)

Nominal line size (DN)	250	300	400	500	600	750	900	1050	
PN 250	Weight (kg)	1021	1497	2245	3266	5080	CF	CF	CF
	A (mm)	1264	1416	1499	1575	1816	CF	CF	CF
	B (mm)	584	673	826	984	1168	CF	CF	CF
	C (mm)	940	1016	1143	1270	1422	CF	CF	CF

Figure 11: Dimensions of enclosure housing

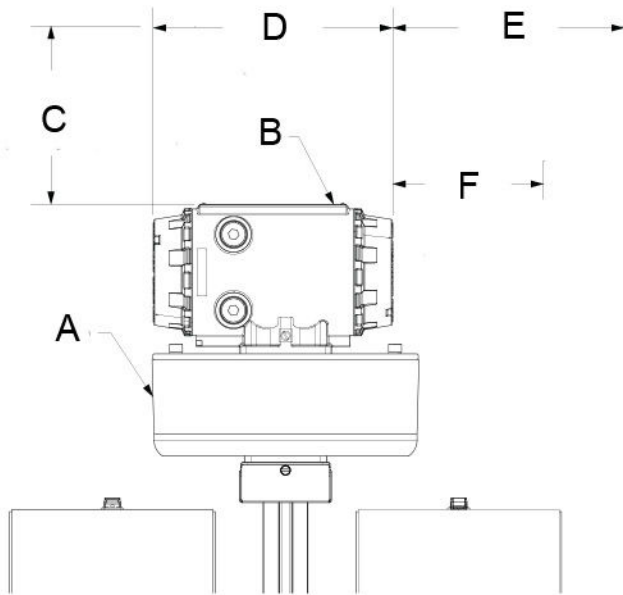

- A. Enclosure base
- B. Enclosure housing⁽⁸⁾
- C. Removal 2 in. (51 mm)
- D. 9.5 in. (241 mm)
- E. Board removal 4.75 in. (121 mm)
- F. Endcap removal 1.75 in. (44 mm)

(8) Enclosure housing may be rotated 360 degrees in 90 degree increments.

Figure 12: Additional dimensions of enclosure housing

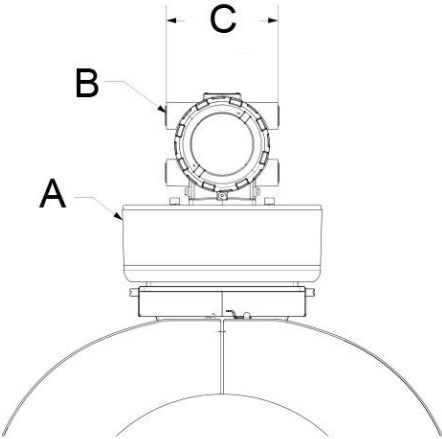

- A. Enclosure base
- B. Enclosure housing
- C. 5.9 in. (150 mm)

Recommended installation

The drawings below represent recommended minimum pipe lengths for the installation of the Rosemount 3418 Gas Ultrasonic Flow Meter. For installation recommendations for the specific application, consult an Emerson Ultrasonics technical specialist. Other lengths or flow conditioners can be accommodated.

Piping Recommendation for Gas Ultrasonic meter (No Flow Conditioner)

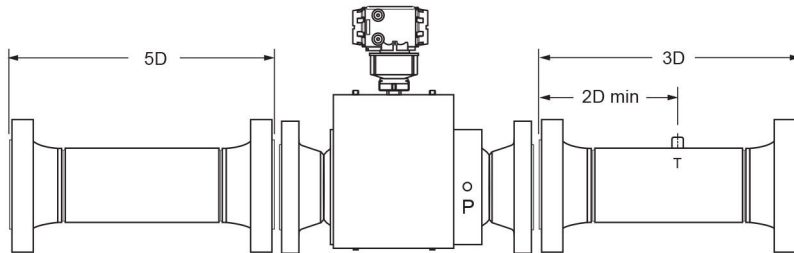

Piping Recommendation for Gas Ultrasonic Meter with a Flow Conditioner (optional)

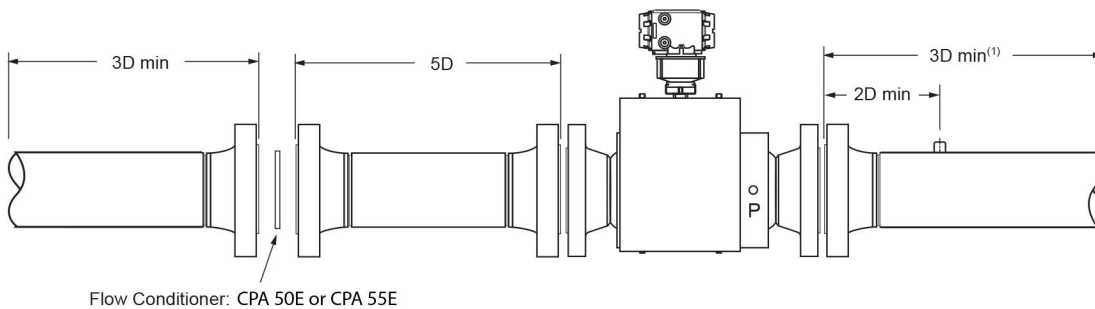

Note

3D min⁽¹⁾ = Additional pipe length may be required for additional taps (i.e. sample probe, test well, etc.).

Piping Recommendation for Bi-directional Gas Ultrasonic Meter

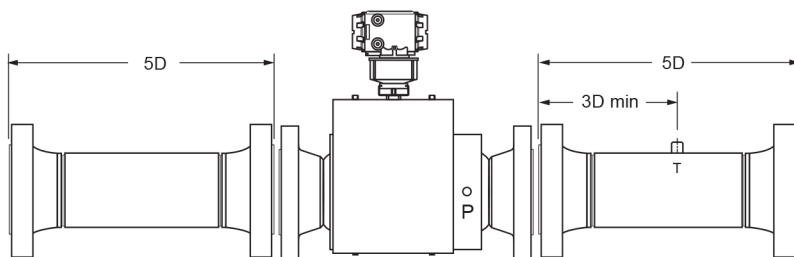

Note

- For best results, flow conditioning is recommended
- D = Nominal pipe size in inches (i.e., 10-inch pipe size, 5D = 50-inch)
- T = Temperature measurement location

- Pressure measurement location provided on meter body
-

Configurator code

#unique 33/unique 33 Connect 42 fig xxh 43t dfc is:

- An example of a configurator code
- For informational purposes only

Not every option is listed and some options are contingent on others. Consult factory for assistance designing your optimal meter.

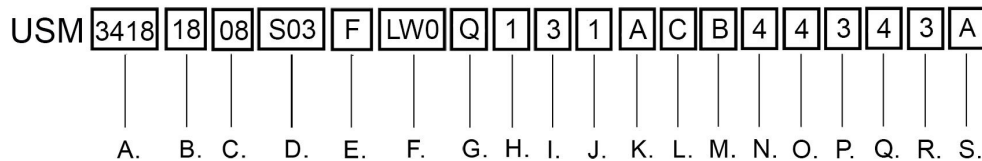

- | | |
|---|---|
| A. Device (see Table 19) | K. Electronics mounting (see Table 29) |
| B. Line size (see Table 20) | L. CPU/Display/Keys (see Table 30) |
| C. Pressure rating (see Table 21) | M. Expansion module (see Table 31) |
| D. Flange type (see Table 22) | N. Wireless (see Table 32) |
| E. Body and flange material (see Table 23) | O. Tagging format (Line size / Pressure rating / Flow parameters) (see Table 33) |
| F. Schedule (pipe bore) (see Table 24) | P. Tagging language (see Table 34) |
| G. Transducer assembly (see Table 25) | Q. Pressure Directive Certification (see Table 35) |
| H. Enclosure type (see Table 26) | R. Electrical approvals (see Table 36) |
| I. Pressure taps (see Table 27) | S. Metrology approval (see Table 37) |
| J. Conduit type (see Table 28) | |

Table 19: Device

Code	Description
3418	3418 8-Path

Table 20: Line Size

Code	Description
10	DN250 (10 in.)
12	DN300 (12 in.)
14	DN350 (14 in.)
16	DN400 (16 in.)
18	DN450 (18 in.)
20	DN500 (20 in.)
24	DN600 (24 in.)
26	DN650 (26 in.)
30	DN750 (30 in.)
36	DN900 (36 in.) ⁽¹⁾

Table 20: Line Size (continued)

Code	Description
42	DN1050 (42 in.) ⁽¹⁾

(1) Consult factory on meter sizes above DN900 (36 in.).

Table 21: Pressure Rating

Code	Description
03	PN 50 / ANSI 300
05	PN 100 / ANSI 600
06	PN 150 / ANSI 900
07	PN 250 / ANSI 1500
08	PN 420 / ANSI 2500

Table 22: Flange type

Code	Description
S01	RF / RF
S02	RTJ / RTJ
S03	FEFA / FEFA
S04	Compact Flange (Special)

Table 23: Body and flange material

Code	Description
F ⁽¹⁾	Forged: Carbon Steel / 316 SS / Duplex SS

(1) Consult factory for specific model code for desired material.

Table 24: Schedule (pipe bore)

Code	Description
LW0	Schedule LW
020	Schedule 20
030	Schedule 30
040	Schedule 40
060	Schedule 60
080	Schedule 80
100	Schedule 100
120	Schedule 120
140	Schedule 140
160	Schedule 160
STD	Schedule STD
XS0	Schedule XS0

Table 25: Transducer assembly

Code	Description
4	T200 [-40 °F to 257 °F (-40 °C to +125 °C)] - Inconel Stalk, FKM O-ring ⁽¹⁾
5	T200 [-40 °F to +257 °F (-40 °C to +125 °C)] - 316/316L SS Standard Stalk, NBR O-ring ⁽¹⁾
6	T200 [-40 °F to +257 °F (-40 °C to +125 °C)] - 316/316L SS Standard Stalk, FKM O-ring ⁽¹⁾
G	T-21 [-4 °F to +212 °F (-20 °C to +100 °C)] - Standard Mounts / Holders, NBR O-ring
I	T-22 [-58 °F to +212 °F (-50 °C to +100 °C)] - Isolated Standard Mounts / 316L Holders, NBR O-ring
L	T-21 [-4 °F to +212 °F (-20 °C to +100 °C)] - Inconel Mounts / Inconel Holders, FKM O-ring
N	T-41 [-58 °F to +212 °F (-50 °C to +100 °C)] - Standard Mounts / Holders, NBR O-ring
O	T-21 [-4 °F to +212 °F (-20 °C to +100 °C)] - Inconel Mounts/316L Holders, FKM O-ring
Z	T-22 [-40 °F to +212 °F (-40 °C to +100 °C)] - Isolated Inconel Mounts / Inconel Holders, FKM O-ring

(1) Available for line sizes up to 42 in. Consult factory for minimum operating pressures below 100 psig.

Table 26: Enclosure type

Code	Description
1	Standard Aluminum
2	Optional Stainless Steel
3	Optional (Retrofit) Aluminum ⁽¹⁾

(1) Expansion module ([Table 31](#)) selections D, E and F only available with aluminum retrofit enclosure. Retrofit enclosure only available with electrical approval ([Table 36](#)) selections 1 and 2.

Table 27: Pressure taps

Code	Description
1	½ in. NPT
3	Pipette

Table 28: Conduit type

Code	Description
1	¾ in. NPT
2	M20 (reducers required)

Table 29: Electronics mounting

Code	Description
A	Integral Mount [up to +140 °F (+60 °C)]

Table 30: CPU/Display

Code	Description
J	I/O Type 4 (6 Frequency/Digital Outputs, 1 Analog Output)
K	I/O Type 4 (6 Frequency/Digital Outputs, 1 Analog Output)/Display

Table 31: Expansion module

Code	Description
A	None
B	One Serial RS232
C	One Serial RS485
D	Two Serial RS232 ⁽¹⁾
E	Two Serial RS485 (2-wire) ⁽¹⁾
F	Serial RS232 and Serial RS485 ⁽¹⁾

(1) Expansion module selections D, E and F only available with aluminum retrofit enclosure. Retrofit enclosure only available with electrical approval ([Table 36](#)) selections 1 and 2.

Table 32: Wireless

Code	Description
A	None
B	THUM

Table 33: Tagging format (Line size / Pressure rating / Flow parameters)

Code	Description
1	Inch / ANSI / US Customary
2	Inch / ANSI / Metric
3	DN / PN / US Customary
4	DN / PN Metric

Table 34: Tagging language

Code	Description
1	English
2	French
3	Russian
4	Chinese

Table 35: Pressure Directive Certification

Code	Description
1	None
2	PED (must select electrical approval (Table 36) code 2)
3	CRN (Canadian Boiler Branch)
4	Russia (EAC)

Table 36: Electrical approvals

Code	Description
1	UL / c-UL
2	ATEX/IECEX
3	INMETRO

Table 36: Electrical approvals (*continued*)

Code	Description
4	EAC - Russia

Table 37: Metrology approval

Code	Description
A	None
B	European Union - MID Directive
C	China (CPA-2015-F101)
D	Brazil (INMETRO)
F	EAC - Russia

For more information: [Emerson.com/global](https://emerson.com/global)

©2025 Emerson. All rights reserved.

Emerson Terms and Conditions of Sale are available upon request. The Emerson logo is a trademark and service mark of Emerson Electric Co. Rosemount is a mark of one of the Emerson family of companies. All other marks are the property of their respective owners.

ROSEMOUNT™

