

## Installation and Flowmeter Orientation

### Annubar Installation Considerations

Table 1. Annubar Straight Run Requirements<sup>(1)</sup>

|                                 | Annubar Products                                   |           |   |                         |
|---------------------------------|--|-----------|---|-------------------------|
|                                 | 3051SFA, 3051CFA, 2051CFA, 485, 585 <sup>(2)</sup> |           |   |                         |
|                                 | Without Straightening Vanes <sup>(3)</sup>         |           | With Straightening Vanes <sup>(4)</sup> |                         |
|                                 | In Plane   | Out Plane | From Disturbance                        | From Straightening Vane |
| <b>Upstream (inlet) side</b>    |  |           |   |                         |
| Reducer                         | 12   | 12        | 8                                       | 4                       |
| Expander                        | 18   | 18        | 8                                       | 4                       |
| Single Elbow (90°) or tee       | 8  | 10        | 8                                       | 4                       |
| Two Elbows in plane             | 11   | 16        | 8                                       | 4                       |
| Two Elbow out of plane          | 23   | 28        | 8                                       | 4                       |
| Butterfly Valve (75-100% open)  | 30   | 30        | 8                                       | 4                       |
| Ball / Gate Valve full open     | 8  | 10        | 8                                       | 4                       |
| <b>Downstream (outlet) side</b> | 4  | 4         | 4                                       | 4                       |

- (1) Consult an Emerson Process Management representative if a disturbance is not listed or if multiple disturbances are present.
- (2) Consult the factory for instructions regarding use in square or rectangular ducts.
- (3) In Plane means the Annubar is in the same plane as the elbow. Out of Plane means the bar is perpendicular to the plane of the upstream elbow. Refer to Figure 1 on page 1.
- (4) Use straightening vane to reduce the required straight run length.

Table 2. 3051SFA, 3051CFA, 2051CFA, 485 Drill Hole Size According to Sensor Size

| Sensor Size | Diameter                                    |
|-------------|---|
| 1           | 3/4-in. (19 mm)                             |
| 2           | 1 <sup>5</sup> / <sub>16</sub> -in. (34 mm) |
| 3           | 2 <sup>1</sup> / <sub>2</sub> -in. (64 mm)  |

Table 3. 585 Drill Hole Size According to Sensor Size

| Sensor Size | Hole Diameter                               |                                |
|-------------|---|--------------------------------|
| 11          | 7/8-in. (23 mm)                             | + 1/32-in (0,80 mm)<br>- 0.00  |
| 22          | 1 <sup>5</sup> / <sub>16</sub> -in. (34 mm) | + 1/16-in. (1,59 mm)<br>- 0.00 |
| 44          | 2 <sup>1</sup> / <sub>2</sub> -in. (64 mm)  | + 1/16-in. (1,59 mm)<br>- 0.00 |

Figure 1. Annubar In plane and Out of plane

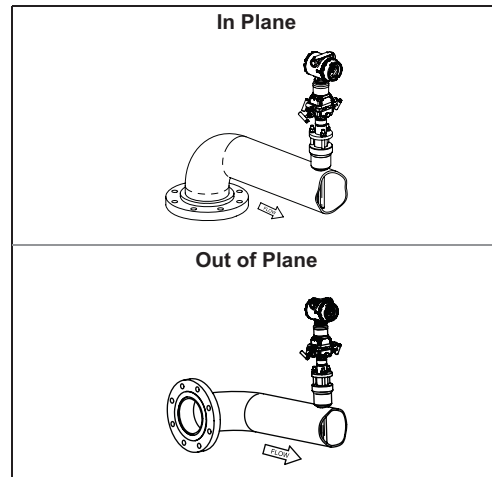

## Orifice Plate Installation Considerations

Table 4. Conditioning Orifice Plate and Compact Orifice Plate Straight Run Requirements<sup>(1)</sup>

|                                 | Conditioning Orifice Plate Products                        |           | Compact Orifice Plate Products                          |                   |
|---------------------------------|--|-----------|---|-------------------|
|                                 | 3051SFC_C, 3051CFCDC, 2051CFCDC, 1595, 405C <sup>(2)</sup> |           | 3051SFC_P, 3051CFCDP, 2051CFCDP, 405P <sup>(3)(4)</sup> |                   |
|                                 | 0.4 Beta   | 0.65 Beta | 0.4 Beta  | 0.65 Beta         |
| <b>Upstream (inlet) side</b>    |  |           |   |                   |
| Reducer                         | 2  | 2         | 5   | 12                |
| Expander                        | 6  | 8         | 12  | 28                |
| Single Elbow (90°) or tee       | 2  | 2         | 16  | 44                |
| Two Elbows in plane             | 2  | 2         | 10  | 44                |
| Two Elbow out of plane          | 2  | 2         | 50  | 60                |
| Butterfly Valve (75-100% open)  | 2  | 5         | 16 <sup>(5)</sup>                                       | 44 <sup>(5)</sup> |
| Ball / Gate Valve full open     | 2  | 2         | 12  | 18                |
| <b>Downstream (outlet) side</b> | 2  | 2         | 6   | 7                 |

- (1) Consult an Emerson Process Management representative if a disturbance is not listed or if multiple disturbances are present.
- (2) For any Beta greater than 0.40, use beta 0.65 recommended lengths. For any Beta ratio less than or equal to 0.40, use beta 0.4 recommended lengths.
- (3) Recommended lengths represented in pipe diameters per ISO 5167.
- (4) Refer to ISO 5167 for recommended lengths when using flow straighteners.
- (5) Recommended lengths not per ISO 5167. Butterfly valves are not listed in the ISO specification.

Table 5. Integral Orifice Plate Straight Run Requirements<sup>(1)(2)(3)</sup>

| Upstream (inlet) side           | 3051SFP, 3051CFP, 2051CFP, 1195 |           |           |           |           |           |
|---------------------------------|---------------------------------|-----------|-----------|-----------|-----------|-----------|
|                                 | <0.20 Beta                      | 0.40 Beta | 0.50 Beta | 0.60 Beta | 0.70 Beta | 0.75 Beta |
| Reducer                         | 20                              | 20        | 20        | 20        | 23        | 25        |
| Expander                        | 22                              | 22        | 23        | 25        | 28        | 30        |
| Single Elbow (90°) or tee       | 24                              | 25        | 25        | 27        | 32        | 35        |
| Two Elbows in plane             | 25                              | 27        | 28        | 31        | 35        | 38        |
| Two Elbows out of plane         | 30                              | 31        | 33        | 37        | 42        | 45        |
| Butterfly Valve fully open      | 22                              | 22        | 23        | 25        | 28        | 30        |
| Gate Valve fully open           | 22                              | 22        | 23        | 25        | 28        | 30        |
| <b>Downstream (outlet) side</b> | 10                              | 10        | 10        | 10        | 10        | 10        |

- (1) Recommended lengths are guidelines based on ASME MFC-14M.
- (2) All straight lengths are expressed as multiples of the pipe inside diameter D and shall be measured from the upstream face of the orifice plate to the disturbance.
- (3) Interpolation of intermediate beta values can be used.

### Orifice Plate Pipe Orientation

Pipe orientation for both 3051SFC, 3051CFC, 2051CFC, 405C, 405P, 3051SFP, 3051CFP, 2051CFP AND 1195.

| Orientation/ Flow Direction | Process <sup>(1)</sup> |        |       |
|-----------------------------|------------------------|--------|-------|
|                             | Gas                    | Liquid | Steam |
| Horizontal                  | D/R                    | D/R    | D/R   |
| Vertical Up                 | R                      | D/R    | R     |
| Vertical Down               | D/R                    | NR     | NR    |

- (1) D = Direct mount acceptable (recommended)  
R = Remote mount acceptable  
NR = Not recommended

### Compact Flowmeter Pipe Centering

Improper centering of any orifice type device can cause an error of up to ±5% in small line sizes. A centering mechanism (centering ring) independent of flange rating comes standard with the 405 Compact Flowmeter Series.

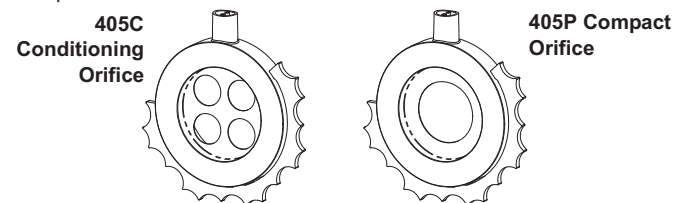

## 1595 Pressure Tap Orientation

Orient the 1595 Conditioning Orifice Plate so that the pressure taps are centered between any 2 (of 4) orifice bore holes. In addition, the pressure taps should be located at 90° to the plane of the last upstream elbow under these conditions:

- with less than 6 upstream pipe diameters
- with a 0.65 Beta

## Pressure Tap Locations

### At Least Six Upstream Pipe Diameters

If the installation location has at least six upstream pipe diameters, the pressure taps can be located between any two of the four holes of the 1595 Orifice Plate. See Figure 2.

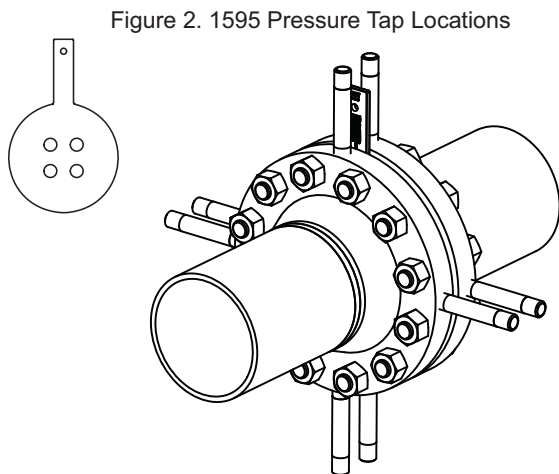

### Within Six Diameters Of An Elbow

If the installation location has less than six upstream pipe diameters, the pressure taps can be located between any two of the four holes of the 1595 Orifice Plate. In addition, the pressure taps must be located 90° from the plane of the elbow. See Figure 3 and Figure 4.

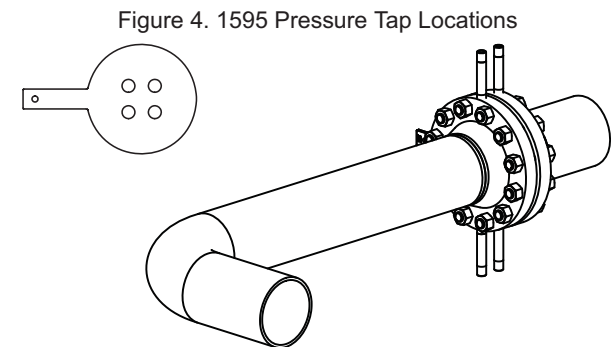
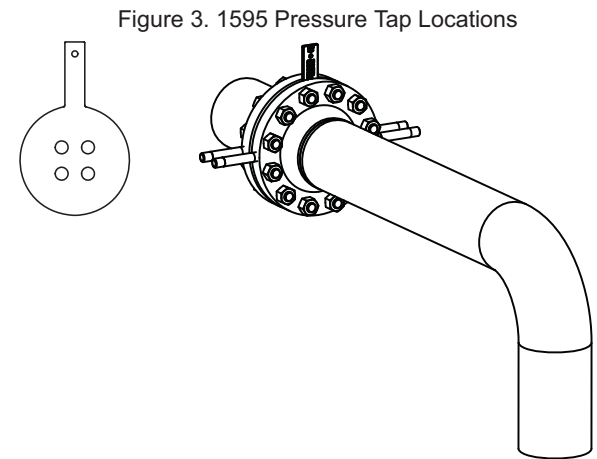

## Annubar Flowmeter Orientation

For 3051SFA, 3051CFA, 2051CFA, 485, 585

### Annubar Direct Mount Flowmeter Orientation (Recommended)<sup>(1)</sup>

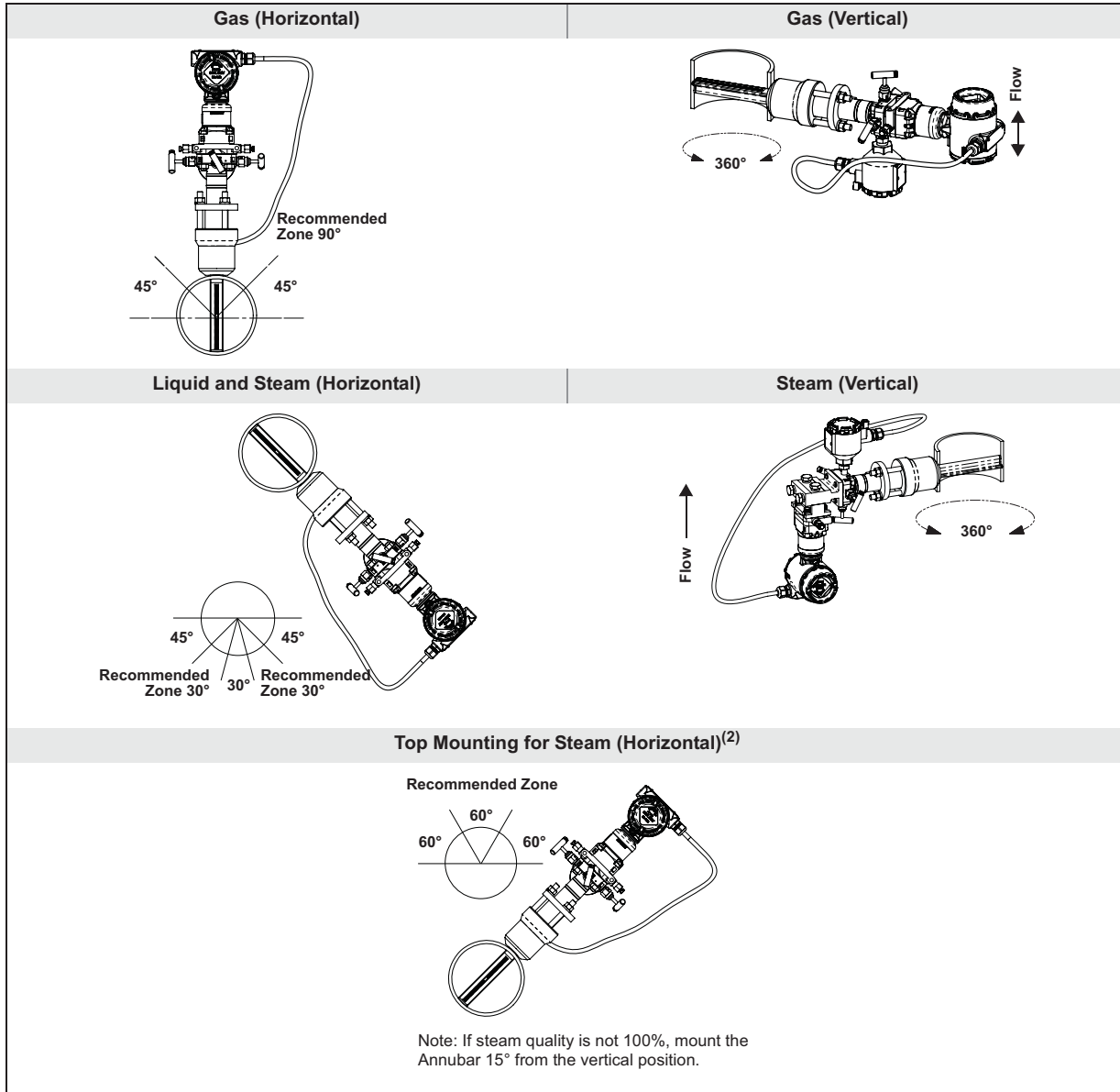

(1) The flowmeter orientation recommendations may vary for the Manual and Gear-Drive Flo-Tap Annubar Types.

(2) Note: This mounting orientation is not recommended for the 585 Annubar Type L (Main Stream Line). For 585 Main Steam Line, use Liquid and Steam (Horizontal) orientation for mounting recommendations.

**Annubar Remount Mount Flowmeter Orientation (Recommended)<sup>(1)</sup>**

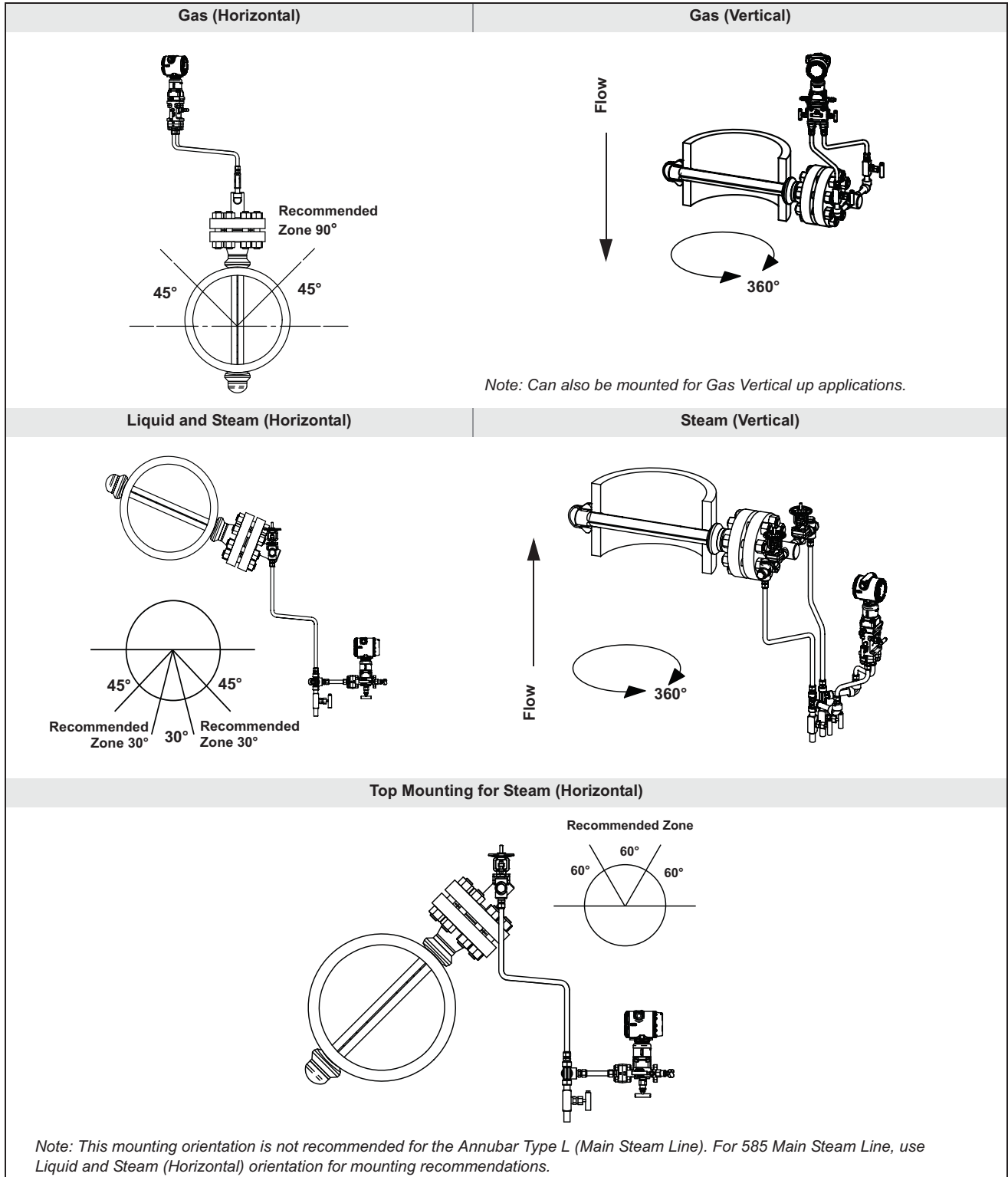

(1) The flowmeter orientation recommendations may vary for the Gear-Drive Flo-Tap Annubar Type.

## 405 Flowmeter Orientation

For 3051SFC, 3051CFC, 2051CFC, 405C, 405P

### 405 Direct Mount Flowmeter Orientation (Recommended)

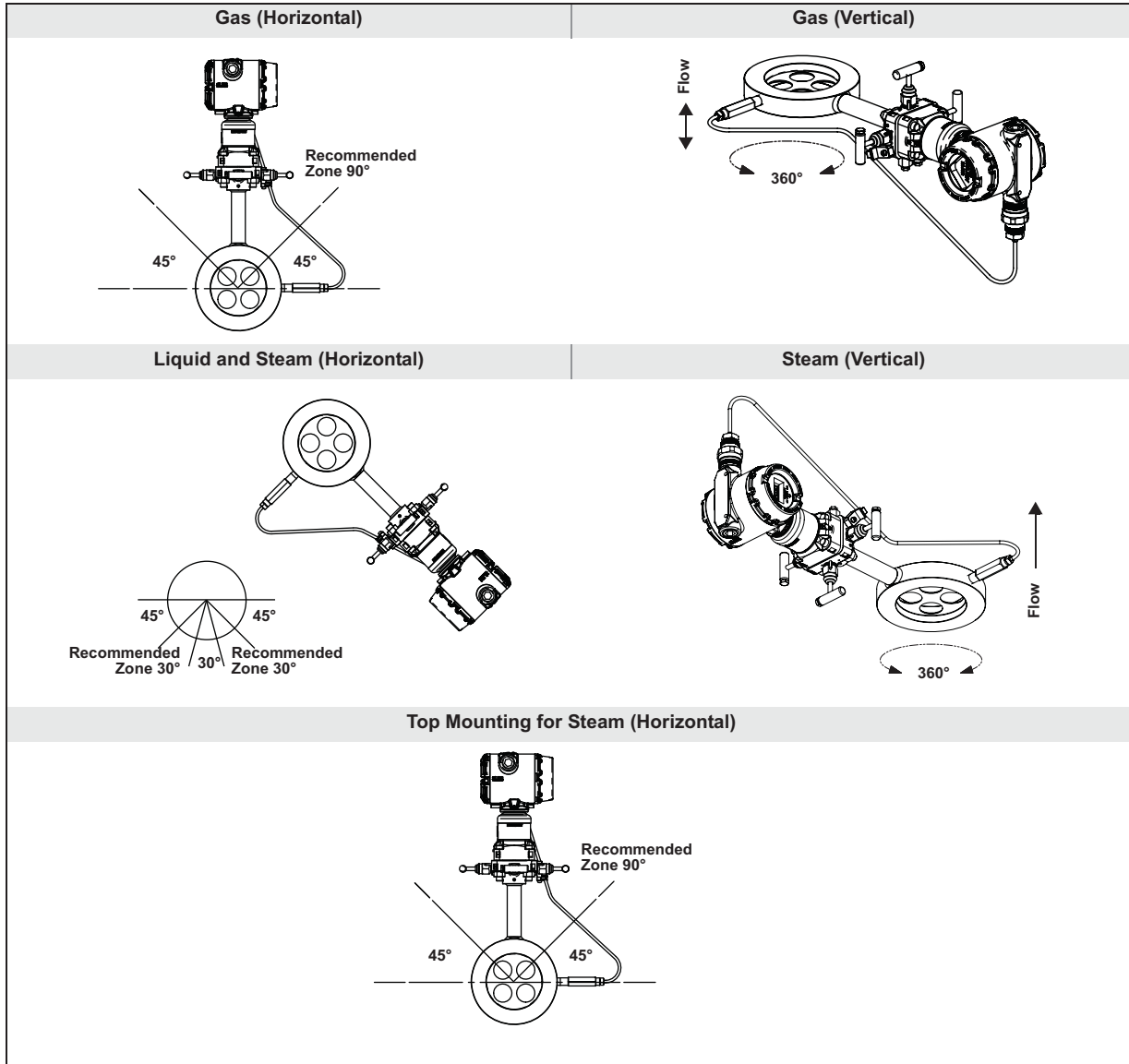

## 405 Remote Mount Flowmeter Orientation (Recommended)

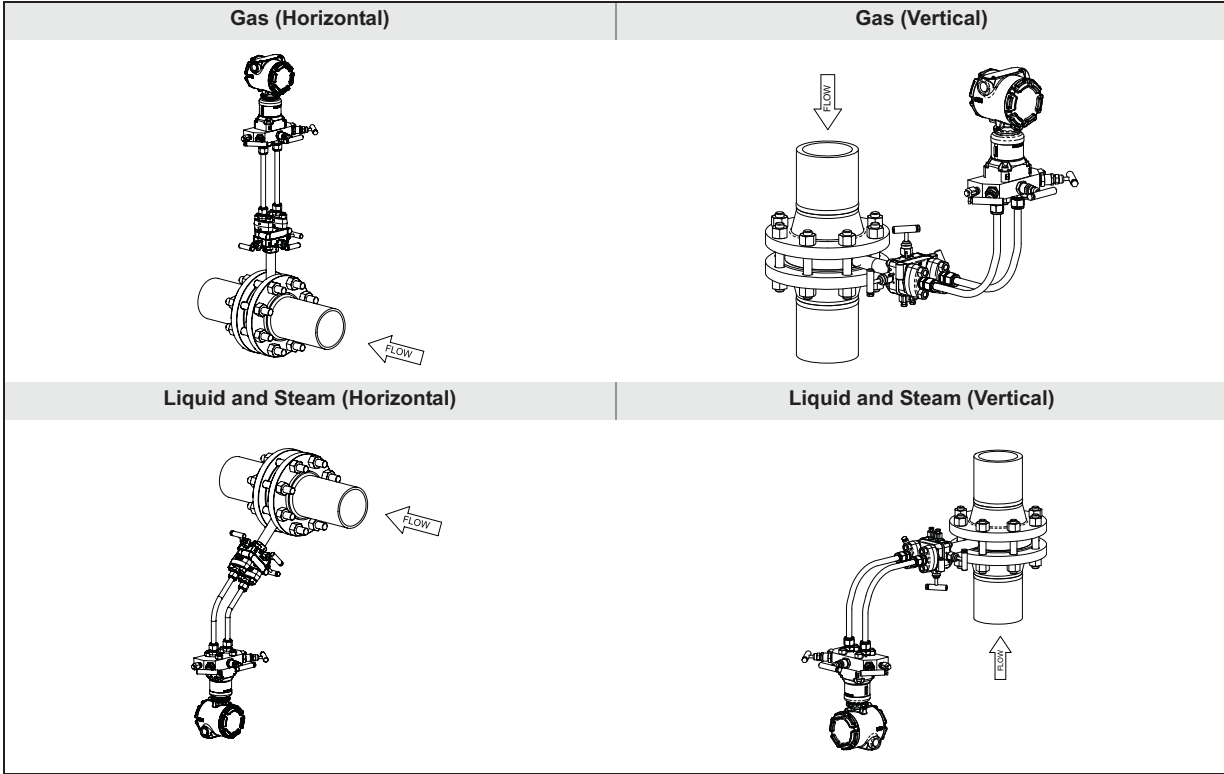

## 1195 Integral Orifice Flowmeter Orientation

For 3051SFP, 3051CFP, 2051CFP, 1195

### 1195 Flowmeter Orientation with Traditional Style Manifold (Recommended)

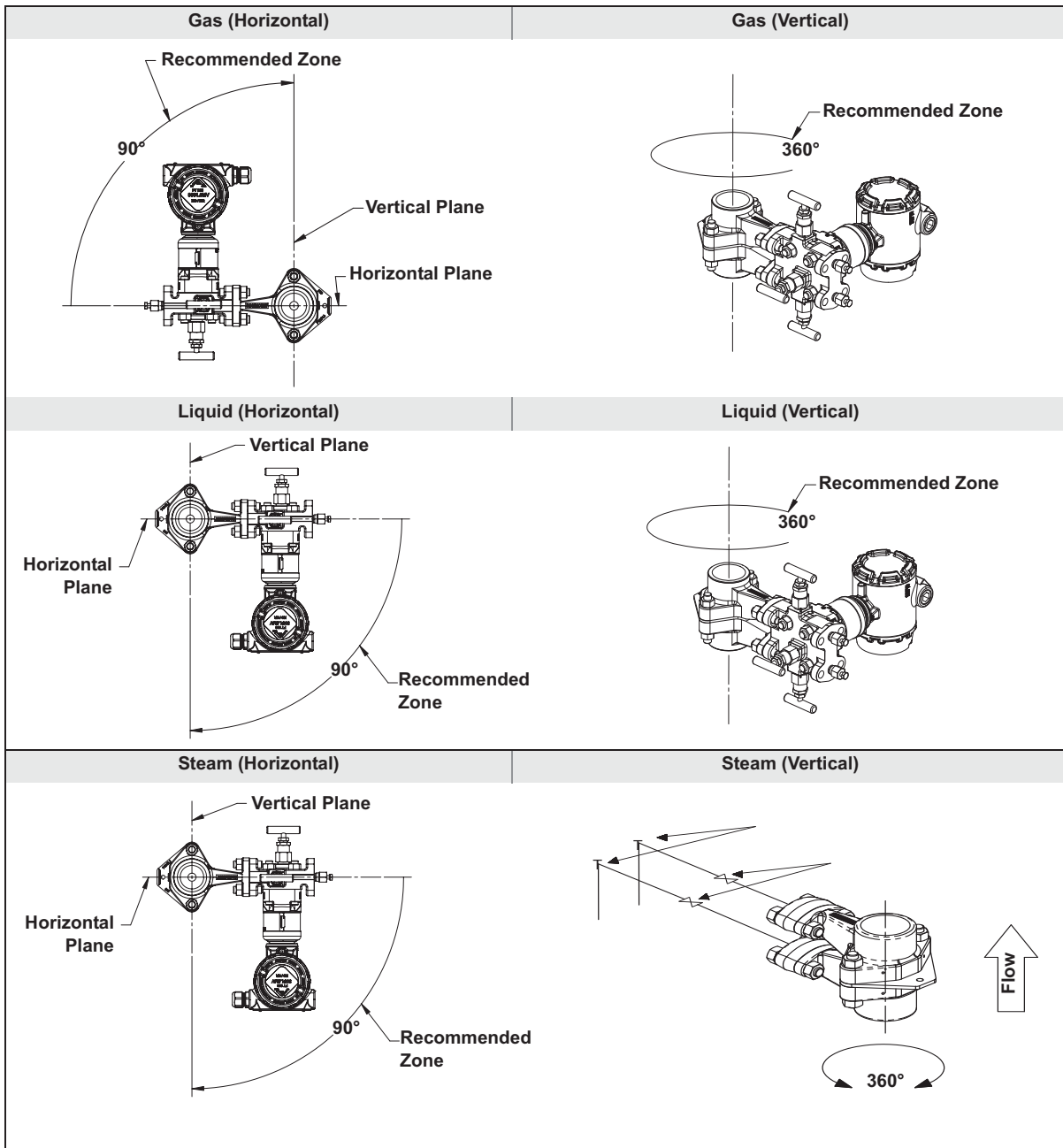

**1195 Flowmeter Orientation with H-Pattern Manifold (Recommended)**

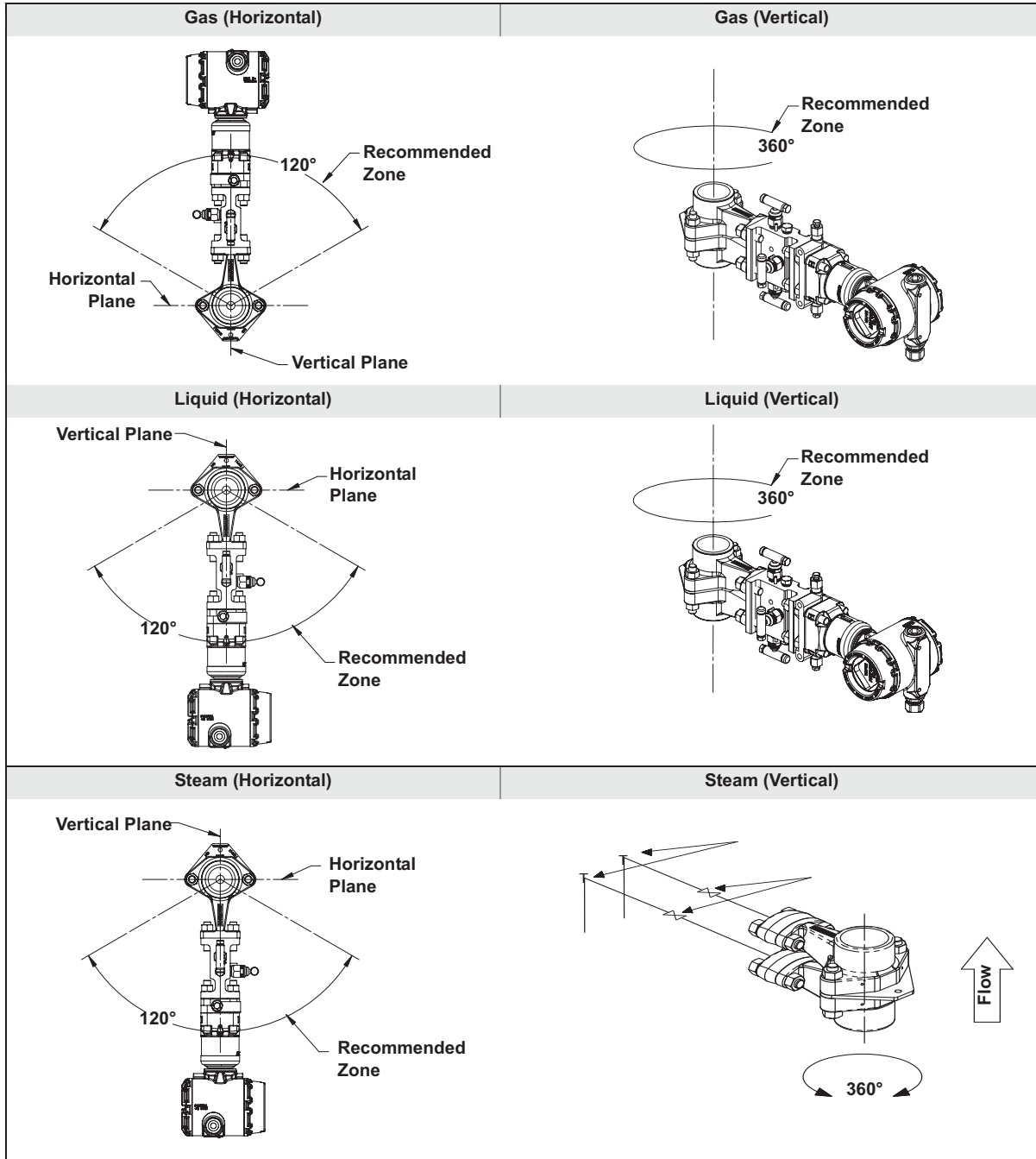



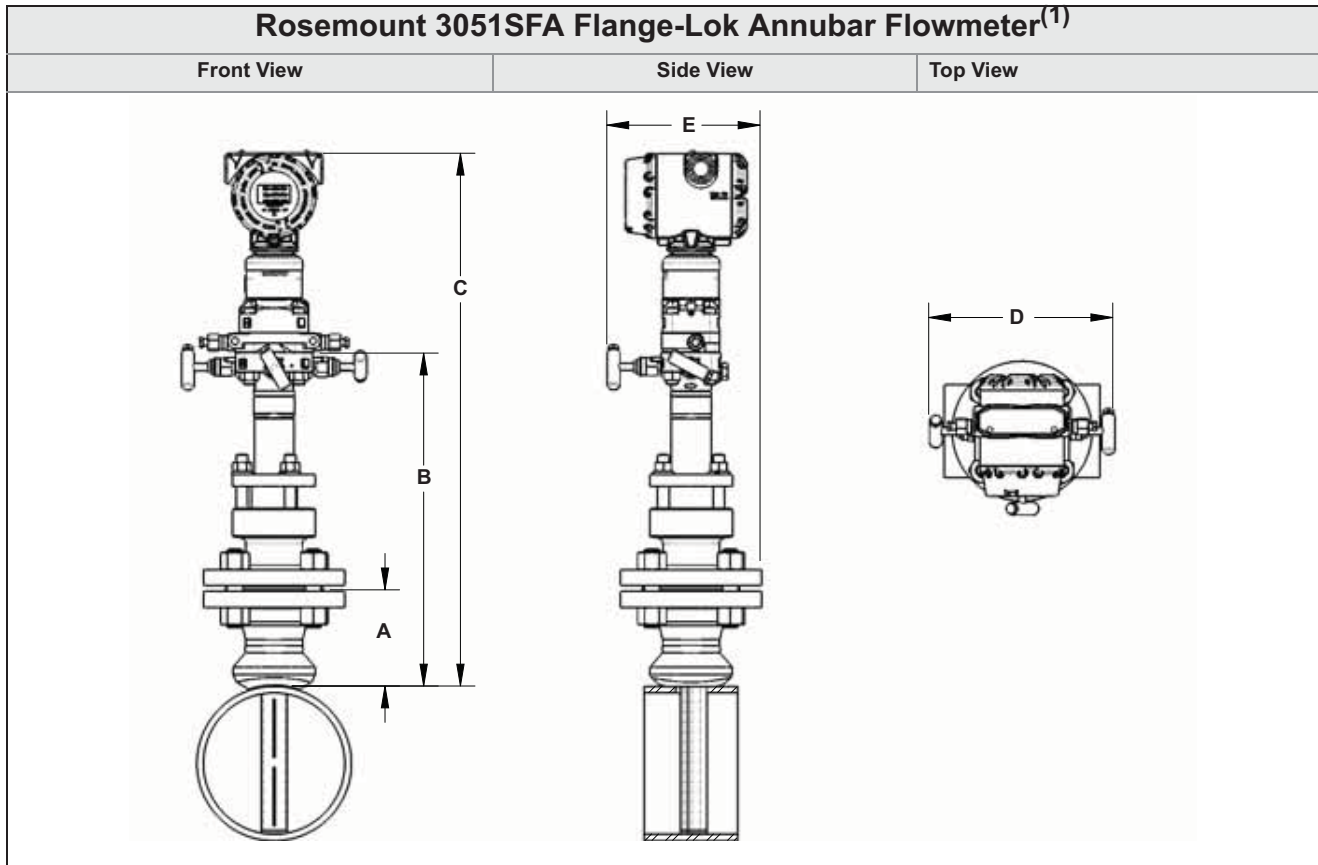

(1) The Flange-Lok Annubar model is available up to 600# ANSI (1440 psig at 100 °F (99 bar at 38 °C)).

Table 7. 3051SFA Flange-Lok Annubar Flowmeter Dimensional Data

| Sensor Size | Flange Size and Rating | A ± 0.125 (3.2) | B ± 0.25 (6.4) | C (Max)       | D (Max)      | E (Max)      |
|-------------|------------------------|-----------------|----------------|---------------|--------------|--------------|
| 1           | 1½ – 150#              | 3.88 (98.6)     | 12.25 (311.2)  | 20.78 (527.8) | 9.00 (228.6) | 6.30 (160.0) |
| 1           | 1½ – 300#              | 4.13 (104.9)    | 12.25 (311.2)  | 20.78 (527.8) | 9.00 (228.6) | 6.86 (174.2) |
| 1           | 1½ – 600#              | 4.44 (112.8)    | 12.25 (311.2)  | 20.78 (527.8) | 9.00 (228.6) | 6.86 (174.2) |
| 1           | DN40/PN16              | 3.09 (78.5)     | 12.25 (311.2)  | 20.78 (527.8) | 9.00 (228.6) | 6.86 (174.2) |
| 1           | DN40/PN40              | 3.21 (81.5)     | 12.25 (311.2)  | 20.78 (527.8) | 9.00 (228.6) | 6.86 (174.2) |
| 1           | DN40/ PN100            | 3.88 (98.6)     | 12.25 (311.2)  | 20.78 (527.8) | 9.00 (228.6) | 6.86 (174.2) |
| 2           | 2 – 150#               | 4.13 (104.9)    | 14.25 (362.0)  | 22.78 (578.6) | 9.00 (228.6) | 6.80 (172.7) |
| 2           | 2 – 300#               | 4.38 (111.3)    | 14.25 (362.0)  | 22.78 (578.6) | 9.00 (228.6) | 7.05 (179.1) |
| 2           | 2 – 600#               | 4.75 (120.7)    | 14.25 (362.0)  | 22.78 (578.6) | 9.00 (228.6) | 7.05 (179.1) |
| 2           | DN50/PN16              | 3.40 (86.4)     | 14.25 (362.0)  | 22.78 (578.6) | 9.00 (228.6) | 7.05 (179.1) |
| 2           | DN50/PN40              | 3.52 (89.4)     | 14.25 (362.0)  | 22.78 (578.6) | 9.00 (228.6) | 7.05 (179.1) |
| 2           | DN50/ PN100            | 4.30 (109.2)    | 14.25 (362.0)  | 22.78 (578.6) | 9.00 (228.6) | 7.05 (179.1) |
| 3           | 3 – 150#               | 4.63 (117.6)    | 17.50 (444.5)  | 26.03 (661.2) | 9.00 (228.6) | 7.55 (191.8) |
| 3           | 3 – 300#               | 5.00 (127.0)    | 17.50 (444.5)  | 26.03 (661.2) | 9.00 (228.6) | 7.93 (201.3) |
| 3           | 3 – 600#               | 5.38 (136.7)    | 17.50 (444.5)  | 26.03 (661.2) | 9.00 (228.6) | 7.93 (201.3) |
| 3           | DN80/PN16              | 3.85 (97.8)     | 17.50 (444.5)  | 26.03 (661.2) | 9.00 (228.6) | 7.93 (201.3) |
| 3           | DN80/PN40              | 4.16 (105.7)    | 17.50 (444.5)  | 26.03 (661.2) | 9.00 (228.6) | 7.93 (201.3) |
| 3           | DN80/ PN100            | 4.95 (125.7)    | 17.50 (444.5)  | 26.03 (661.2) | 9.00 (228.6) | 7.93 (201.3) |

Dimensions are in inches (millimeters)

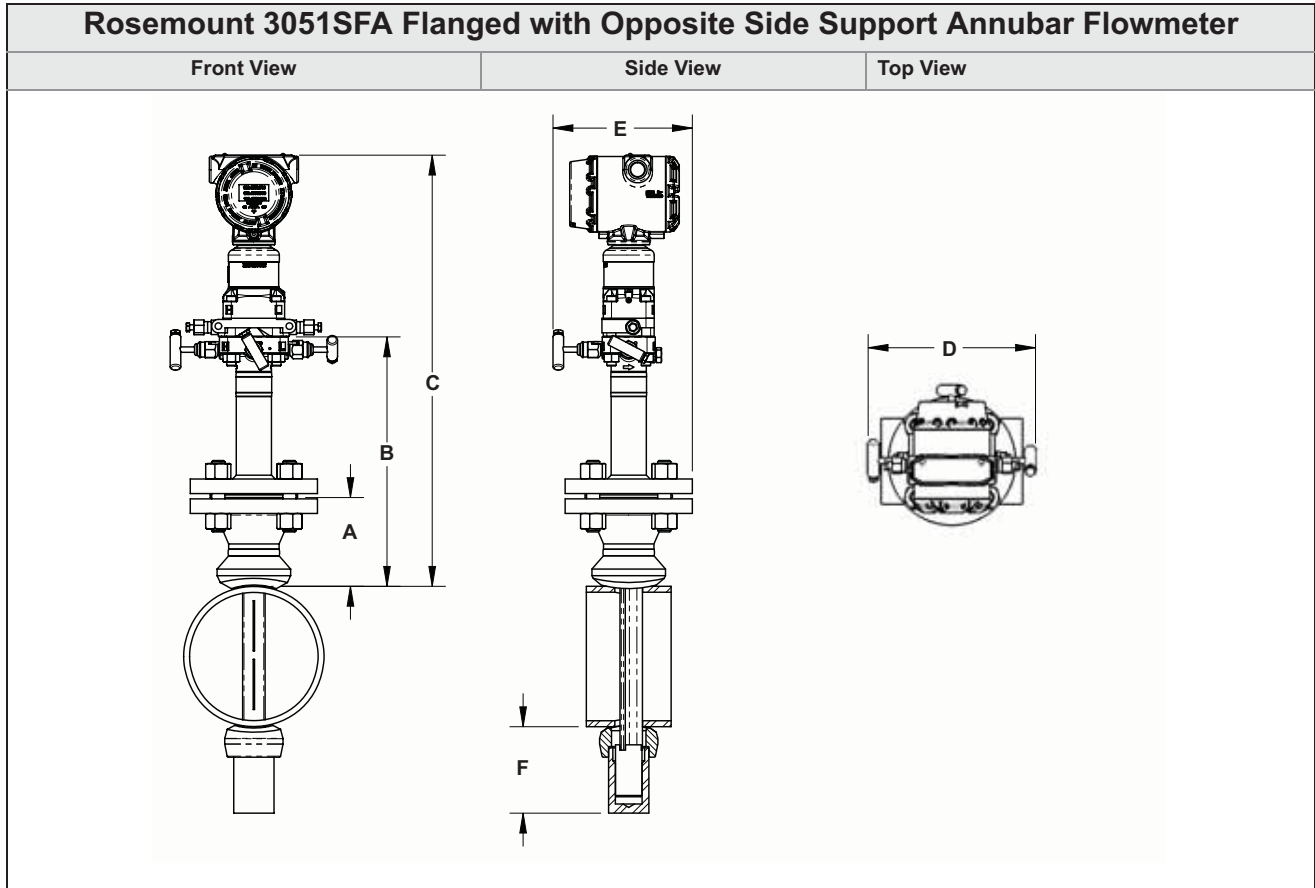

Table 8. 3051SFA Flanged Annubar Flowmeter Dimensional Data

| Sensor Size | Flange Size and Rating                | A ± 0.125 (3.2) | B ± 0.25 (6.4) | C ± 0.25 (6.4) | D (Max)      | E (Max)      | F (Max)      |
|-------------|---------------------------------------|-----------------|----------------|----------------|--------------|--------------|--------------|
| 1           | 1 <sup>1</sup> / <sub>2</sub> – 150#  | 3.88 (98.6)     | 11.00 (279.4)  | 19.53 (496.1)  | 9.00 (228.6) | 6.30 (160.0) | 3.50 (88.9)  |
| 1           | 1 <sup>1</sup> / <sub>2</sub> – 300#  | 4.13 (104.9)    | 11.00 (279.4)  | 19.53 (496.1)  | 9.00 (228.6) | 6.86 (174.2) | 3.50 (88.9)  |
| 1           | 1 <sup>1</sup> / <sub>2</sub> – 600#  | 4.44 (112.8)    | 11.00 (279.4)  | 19.53 (496.1)  | 9.00(228.6)  | 6.86 (174.2) | 3.50 (88.9)  |
| 1           | DN40/PN16                             | 3.09 (78.5)     | 11.00 (279.4)  | 19.53 (496.1)  | 9.00 (228.6) | 6.86 (174.2) | 3.50 (88.9)  |
| 1           | DN40/PN40                             | 3.21 (81.5)     | 11.00 (279.4)  | 19.53 (496.1)  | 9.00 (228.6) | 6.86 (174.2) | 3.50 (88.9)  |
| 1           | DN40/ PN100                           | 3.88 (98.6)     | 11.00 (279.4)  | 19.53 (496.1)  | 9.00(228.6)  | 6.86 (174.2) | 3.50 (88.9)  |
| 1           | 1 <sup>1</sup> / <sub>2</sub> – 900#  | 4.94 (125.5)    | 9.31 (236.5)   | —              | —            | —            | 3.50 (88.9)  |
| 1           | 1 <sup>1</sup> / <sub>2</sub> – 1500# | 4.94 (125.5)    | 9.31 (236.5)   | —              | —            | —            | 3.50 (88.9)  |
| 1           | 1 <sup>1</sup> / <sub>2</sub> – 2500# | 6.76 (171.7)    | 11.63 (295.4)  | —              | —            | —            | 4.00 (101.6) |
| 2           | 2 – 150#                              | 4.13 (104.9)    | 12.00 (304.8)  | 20.53 (521.5)  | 9.00 (228.6) | 6.80 (172.7) | 5.00 (127.0) |
| 2           | 2 – 300#                              | 4.38 (111.3)    | 12.00 (304.8)  | 20.53 (521.5)  | 9.00 (228.6) | 7.05 (179.1) | 5.00 (127.0) |
| 2           | 2 – 600#                              | 4.75 (120.7)    | 12.00 (304.8)  | 20.53 (521.5)  | 9.00 (228.6) | 7.05 (179.1) | 5.00 (127.0) |
| 2           | DN50/PN16                             | 3.40 (86.4)     | 12.00 (304.8)  | 20.53 (521.5)  | 9.00 (228.6) | 7.05 (179.1) | 5.00 (127.0) |
| 2           | DN50/PN40                             | 3.52 (89.4)     | 12.00 (304.8)  | 20.53 (521.5)  | 9.00 (228.6) | 7.05 (179.1) | 5.00 (127.0) |
| 2           | DN50/ PN100                           | 4.30 (109.2)    | 12.00 (304.8)  | 20.53 (521.5)  | 9.00 (228.6) | 7.05 (179.1) | 5.00 (127.0) |
| 2           | 2 – 900#                              | 5.88 (149.4)    | 10.50 (266.7)  | —              | —            | —            | 5.00 (127.0) |
| 2           | 2 – 1500#                             | 5.88 (149.4)    | 10.50 (266.7)  | —              | —            | —            | 5.00 (127.0) |
| 2           | 3 – 2500#                             | 9.88 (251.0)    | 15.63 (397.0)  | —              | —            | —            | 4.50 (114.3) |
| 3           | 3 – 150#                              | 4.63 (117.6)    | 13.50 (342.9)  | 22.03 (559.6)  | 9.00 (228.6) | 7.55 (191.8) | 4.00 (101.6) |
| 3           | 3 – 300#                              | 5.00 (127.0)    | 13.50 (342.9)  | 22.03 (559.6)  | 9.00 (228.6) | 7.93 (201.3) | 4.00 (101.6) |
| 3           | 3 – 600#                              | 5.38 (136.7)    | 13.50 (342.9)  | 22.03 (559.6)  | 9.00 (228.6) | 7.93 (201.3) | 4.00 (101.6) |

Table 8. 3051SFA Flanged Annubar Flowmeter Dimensional Data

| Sensor Size                                   | Flange Size and Rating | A ± 0.125 (3.2) | B ± 0.25 (6.4) | C ± 0.25 (6.4) | D (Max)      | E (Max)      | F (Max)      |
|---|------------------------|-----------------|----------------|----------------|--------------|--------------|--------------|
| 3   | DN80/PN16              | 3.85 (97.8)     | 13.50 (342.9)  | 22.03 (559.6)  | 9.00 (228.6) | 7.93 (201.3) | 4.00 (101.6) |
| 3   | DN80/PN40              | 4.16 (105.7)    | 13.50 (342.9)  | 22.03 (559.6)  | 9.00 (228.6) | 7.93 (201.3) | 4.00 (101.6) |
| 3   | DN80/ PN100            | 4.95 (125.7)    | 13.50 (342.9)  | 22.03 (559.6)  | 9.00 (228.6) | 7.93 (201.3) | 4.00 (101.6) |
| 3   | 4 – 900#               | 8.19 (208.0)    | 13.06 (331.7)  | —              | —            | —            | 7.00 (177.8) |
| 3   | 4 – 1500#              | 8.56 (217.4)    | 13.81 (350.8)  | —              | —            | —            | 7.00 (177.8) |
| 3   | 4 – 2500#              | 11.19 (284.2)   | 17.31 (439.7)  | —              | —            | —            | 7.00 (177.8) |
| <i>Dimensions are in inches (millimeters)</i> |                        |                 |                |                |              |              |              |

# Rosemount DP Flow

**Product Data Sheet**  
00813-1000-4485, Rev CA  
November 2011

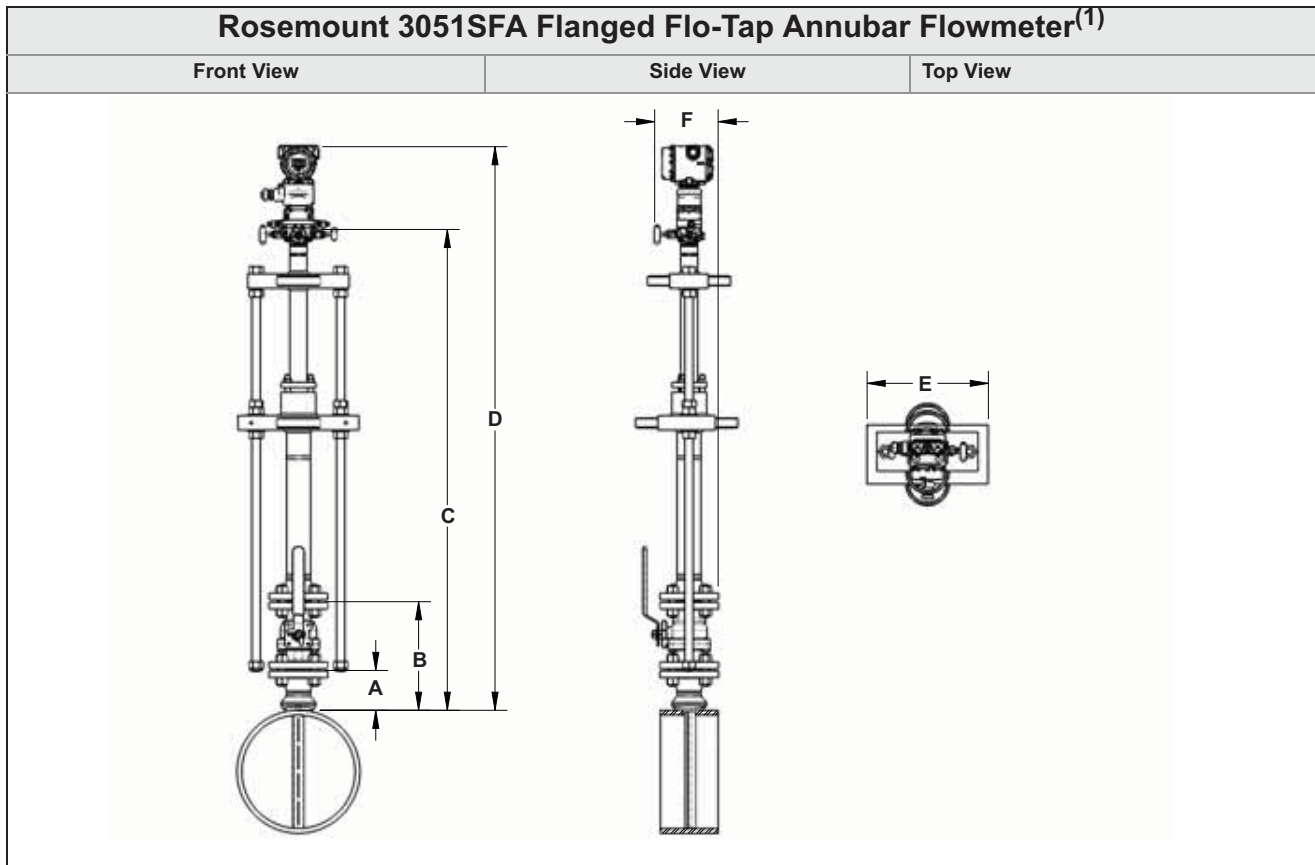

(1) The Flanged Flo-Tap Annubar Flowmeter is available with either the manual or gear drive options.

Table 9. 3051SFA Flanged Flo-Tap Annubar Flowmeter Dimensional Data

| Sensor Size | Flange Size and Rating    | A ± 0.125 (3.2) | B ± 0.25 (6.4) | C <sup>1</sup> (Max) (Gear Drive) | C <sup>1</sup> (Max) (Manual) | D (Max)          | E (Max)       | F (Max)      |
|-------------|---------------------------|-----------------|----------------|-----------------------------------|-------------------------------|------------------|---------------|--------------|
| 1           | 1½ – 150#                 | 3.88 (98.6)     | 10.50 (266.7)  | —                                 | 17.77 (451.4)                 | C + 8.53 (216.7) | 10.50 (266.7) | 6.30 (160.0) |
| 1           | 1½ – 300#                 | 4.13 (104.9)    | 11.75 (298.5)  | —                                 | 17.77 (451.4)                 | C + 8.53 (216.7) | 10.50 (266.7) | 6.86 (174.2) |
| 1           | 1½ – 600#                 | 4.44 (112.8)    | 14.06 (357.2)  | —                                 | 17.77 (451.4)                 | C + 8.53 (216.7) | 10.50 (266.7) | 6.86 (174.2) |
| 1           | DN40/PN16 <sup>(1)</sup>  | 3.09 (78.5)     | See Note 1.    | —                                 | 17.77 (451.4)                 | C + 8.53 (216.7) | 10.50 (266.7) | 6.86 (174.2) |
| 1           | DN40/PN40 <sup>(1)</sup>  | 3.21 (81.5)     | See Note 1.    | —                                 | 17.77 (451.4)                 | C + 8.53 (216.7) | 10.50 (266.7) | 6.86 (174.2) |
| 1           | DN40/PN100 <sup>(1)</sup> | 3.88 (98.6)     | See Note 1.    | —                                 | 17.77 (451.4)                 | C + 8.53 (216.7) | 10.50 (266.7) | 6.86 (174.2) |
| 2           | 2 – 150#                  | 4.13 (104.9)    | 11.25 (285.8)  | 24.44 (620.8)                     | 21.20 (538.5)                 | C + 8.53 (216.7) | 12.56 (319.0) | 6.80 (172.7) |
| 2           | 2 – 300#                  | 4.38 (111.3)    | 13.00 (330.2)  | 24.44 (620.8)                     | 21.20 (538.5)                 | C + 8.53 (216.7) | 12.56 (319.0) | 7.05 (179.1) |
| 2           | 2 – 600#                  | 4.75 (120.7)    | 16.38 (416.0)  | 24.44 (620.8)                     | 21.20 (538.5)                 | C + 8.53 (216.7) | 12.56 (319.0) | 7.05 (179.1) |
| 2           | DN50/PN16 <sup>(1)</sup>  | 3.40 (86.4)     | See Note 1.    | 24.44 (620.8)                     | 21.20 (538.5)                 | C + 8.53 (216.7) | 12.56 (319.0) | 7.05 (179.1) |
| 2           | DN50/PN40 <sup>(1)</sup>  | 3.52 (89.4)     | See Note 1.    | 24.44 (620.8)                     | 21.20 (538.5)                 | C + 8.53 (216.7) | 12.56 (319.0) | 7.05 (179.1) |
| 2           | DN50/PN100 <sup>(1)</sup> | 4.30 (109.2)    | See Note 1.    | 24.44 (620.8)                     | 21.20 (538.5)                 | C + 8.53 (216.7) | 12.56 (319.0) | 7.05 (179.1) |
| 3           | 3 – 150#                  | 4.63 (117.6)    | 12.75 (323.9)  | 26.37 (669.8)                     | 23.14 (587.8)                 | C + 8.53 (216.7) | 14.13 (358.9) | 7.55 (191.8) |
| 3           | 3 – 300#                  | 5.00 (127.0)    | 16.25 (412.8)  | 26.37 (669.8)                     | 23.14 (587.8)                 | C + 8.53 (216.7) | 14.13 (358.9) | 7.93 (201.3) |
| 3           | 3 – 600#                  | 5.38 (136.7)    | 19.50 (495.3)  | 26.37 (669.8)                     | 23.14 (587.8)                 | C + 8.53 (216.7) | 14.13 (358.9) | 7.93 (201.3) |
| 3           | DN80/PN16 <sup>(1)</sup>  | 3.85 (97.8)     | See Note 1.    | 26.37 (669.8)                     | 23.14 (587.8)                 | C + 8.53 (216.7) | 14.13 (358.9) | 7.93 (201.3) |
| 3           | DN80/PN40 <sup>(1)</sup>  | 4.16 (105.7)    | See Note 1.    | 26.37 (669.8)                     | 23.14 (587.8)                 | C + 8.53 (216.7) | 14.13 (358.9) | 7.93 (201.3) |
| 3           | DN80/PN100 <sup>(1)</sup> | 4.95 (125.7)    | See Note 1.    | 26.37 (669.8)                     | 23.14 (587.8)                 | C + 8.53 (216.7) | 14.13 (358.9) | 7.93 (201.3) |

Dimensions are in inches (millimeters)

(1) DIN Valves are not offered

Inserted, C Dimension = Pipe I.D. + Wall Thickness + B + C<sup>1</sup>

Retracted, C Dimension = 2 x (Pipe I.D. + Wall Thickness + B) + C<sup>1</sup>

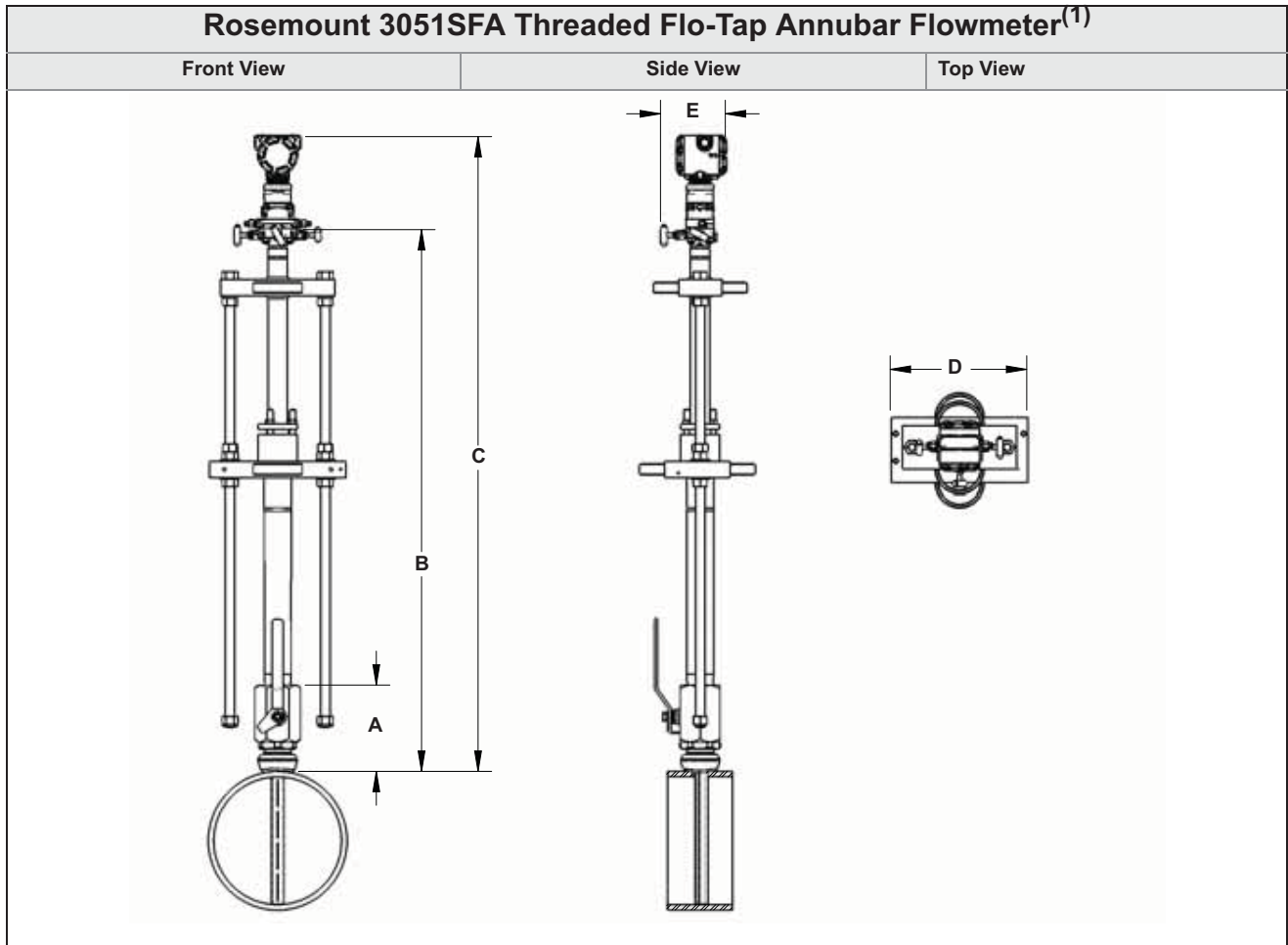

(1) The Threaded Flo-Tap Annubar Flowmeter is available with both the manual and gear drive options.

Table 10. 3051SFA Threaded Flo-Tap Annubar Flowmeter Dimensional Data

| Sensor Size  | A ± 0.50<br>(12.7) | B <sup>1</sup> (Max)<br>(Gear Drive) | B <sup>1</sup> (Max)<br>(Manual) | C (Max)          | D (Max)       | E (Max)      |
|--|--------------------|--------------------------------------|----------------------------------|------------------|---------------|--------------|
|  |                    |                                      |                                  | B + 8.53 (216.7) |               |              |
| 1  | 7.51 (190.9)       | —                                    | 16.96 (430.8)                    | B + 8.53 (216.7) | 10.50 (266.7) | 6.90 (175.3) |
| 2  | 8.17 (207.5)       | 23.62 (599.9)                        | 20.39 (517.9)                    | B + 8.53 (216.7) | 12.56 (319.0) | 6.90 (175.3) |
| <i>Sensor Size 3 is not available in a Threaded Flo-Tap.</i> |                    |                                      |                                  |                  |               |              |
| <i>Dimensions are in inches (millimeters)</i>                |                    |                                      |                                  |                  |               |              |

Inserted, B Dimension = Pipe I.D. + Wall Thickness + A + B<sup>1</sup>  
 Retracted, B Dimension = 2 x (Pipe I.D. + Wall Thickness + A) + B<sup>1</sup>

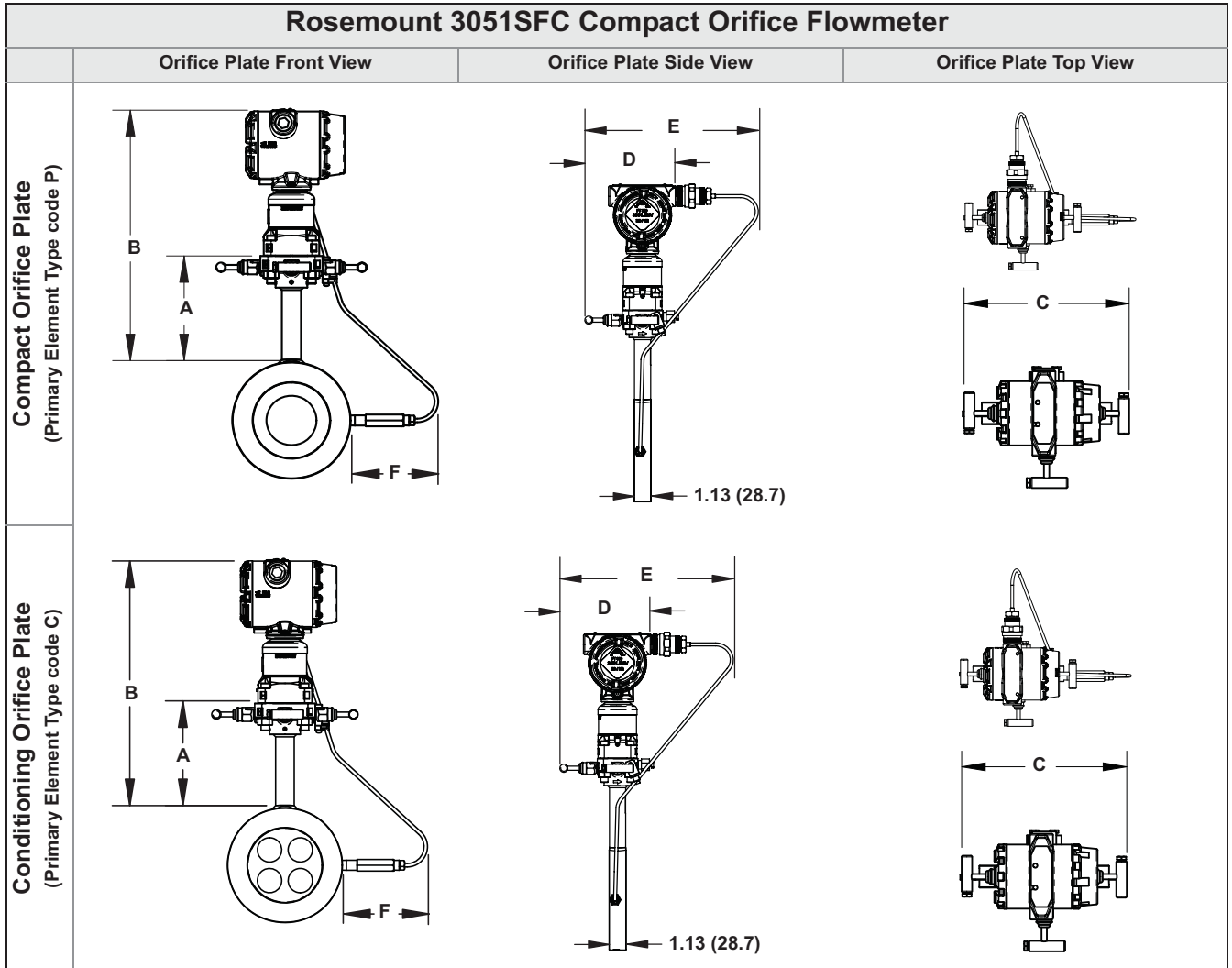

Table 11. 3051SFC Compact Orifice Dimensional Data<sup>(1)</sup>

| Primary Element Type | A          | B                      | Transmitter Height | C  | D  | E  | F               |
|----------------------|------------|------------------------|--------------------|--|--|--|-----------------|
| Type P and C         | 5.62 (143) | Transmitter Height + A | 7.70 (196)         | 7.75 (197) - closed<br>8.25 (210) - open | 6.00 (152) - closed<br>6.25 (159) - open | 10.2 (257.8) - closed<br>10.4 (264.2) - open | Max of 6.7 (71) |

<sup>(1)</sup> Measurement in inches (millimeters).



## 3051CF DIMENSIONAL DRAWINGS

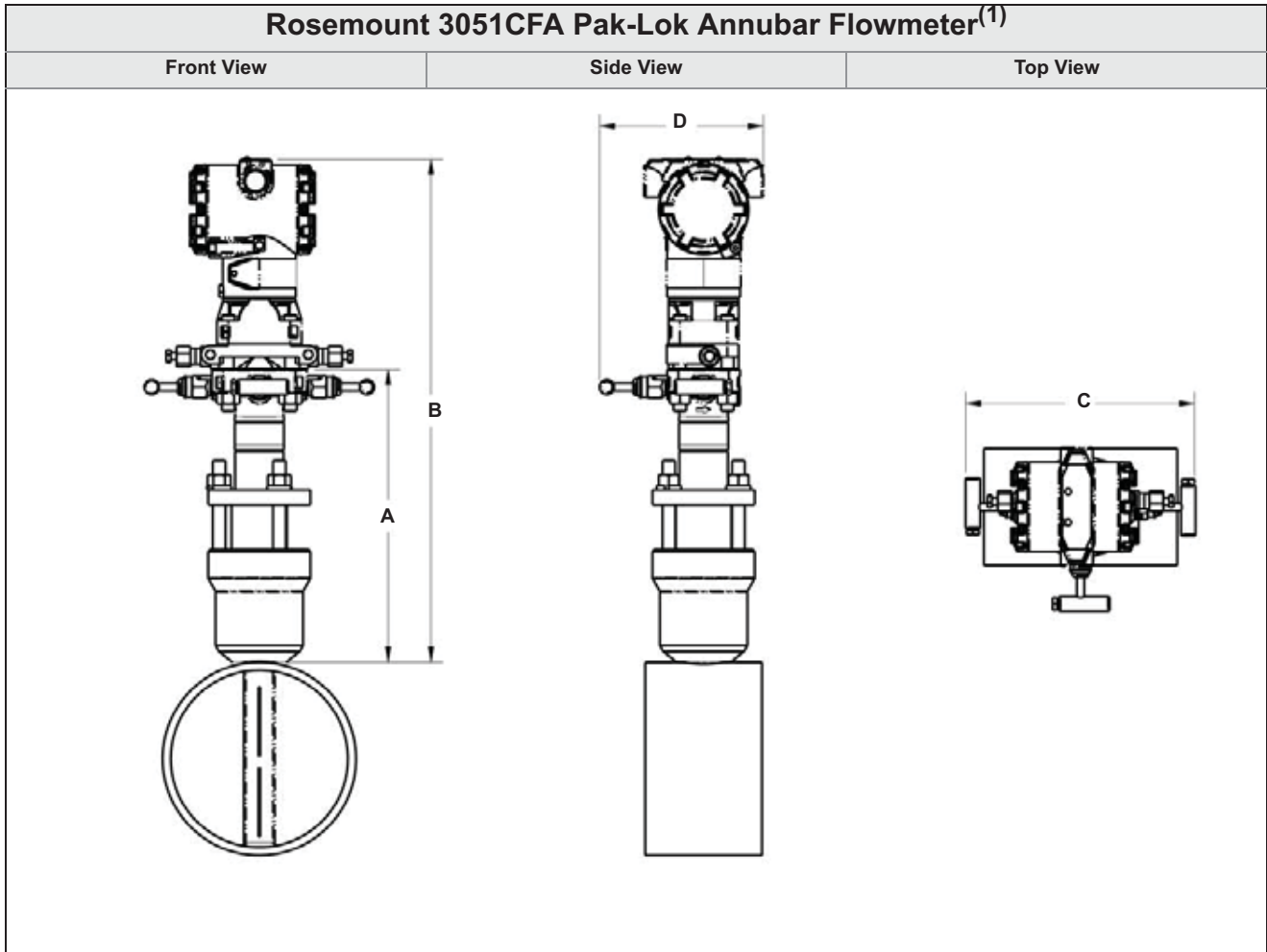

(1) The Pak-Lok Annubar model is available up to 600# ANSI (1440 psig at 100 °F (99 bar at 38 °C)).

Table 13. 3051CFA Pak-Lok Annubar Flowmeter Dimensional Data

| Sensor Size | A (Max)       | B (Max)       | C (Max)      | D (Max)      |
|-------------|---------------|---------------|--------------|--------------|
| 1           | 8.50 (215.9)  | 14.60 (370.8) | 9.00 (228.6) | 6.00 (152.4) |
| 2           | 11.0 (279.4)  | 16.35 (415.3) | 9.00 (228.6) | 6.00 (152.4) |
| 3           | 12.00 (304.8) | 19.10 (485.1) | 9.00 (228.6) | 6.00 (152.4) |

*Dimensions are in inches (millimeters)*

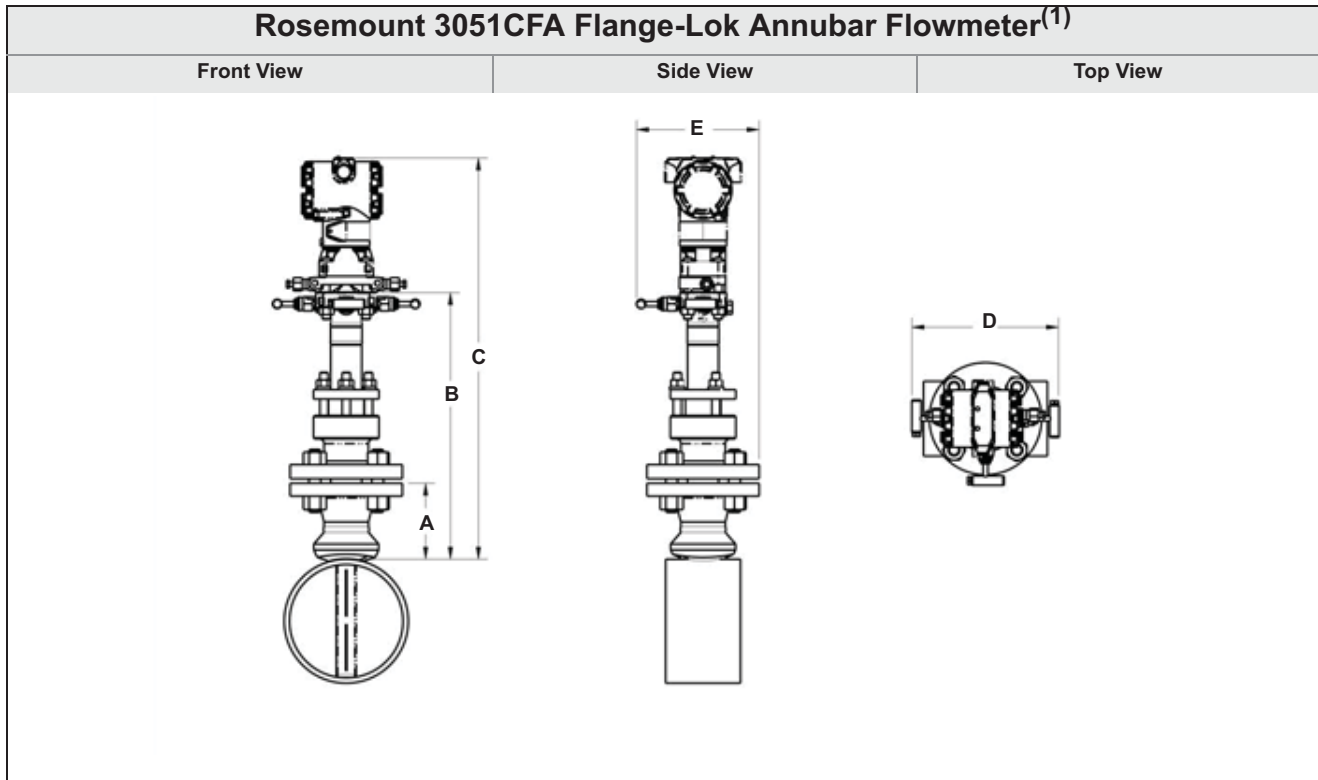

(1) The Flange-Lok Annubar model can be direct mounted up to 600# ANSI (1440 psig at 100 °F (99 bar at 38 °C)).

Table 14. 3051CFA Flange-Lok Annubar Flowmeter Dimensional Data

| Sensor Size | Flange Size and Rating | A ± 0.125 (3.2) | B ± 0.25 (6.4) | C (Max)       | D (Max)      | E (Max)      |
|-------------|------------------------|-----------------|----------------|---------------|--------------|--------------|
| 1           | 1½ – 150#              | 3.88 (98.6)     | 12.25 (311.2)  | 19.35 (491.5) | 9.00 (228.6) | 6.30 (160.0) |
| 1           | 1½ – 300#              | 4.13 (104.9)    | 12.25 (311.2)  | 19.35 (491.5) | 9.00 (228.6) | 6.86 (174.2) |
| 1           | 1½ – 600#              | 4.44 (112.8)    | 12.25 (311.2)  | 19.35 (491.5) | 9.00 (228.6) | 6.86 (174.2) |
| 1           | DN40/PN16              | 3.09 (78.5)     | 12.25 (311.2)  | 19.35 (491.5) | 9.00 (228.6) | 6.86 (174.2) |
| 1           | DN40/PN40              | 3.21 (81.5)     | 12.25 (311.2)  | 19.35 (491.5) | 9.00 (228.6) | 6.86 (174.2) |
| 1           | DN40/ PN100            | 3.88 (98.6)     | 12.25 (311.2)  | 19.35 (491.5) | 9.00 (228.6) | 6.86 (174.2) |
| 2           | 2 – 150#               | 4.13 (104.9)    | 14.25 (362.0)  | 21.35 (542.3) | 9.00 (228.6) | 6.80 (172.7) |
| 2           | 2 – 300#               | 4.38 (111.3)    | 14.25 (362.0)  | 21.35 (542.3) | 9.00 (228.6) | 7.05 (179.1) |
| 2           | 2 – 600#               | 4.75 (120.7)    | 14.25 (362.0)  | 21.35 (542.3) | 9.00 (228.6) | 7.05 (179.1) |
| 2           | DN50/PN16              | 3.40 (86.4)     | 14.25 (362.0)  | 21.35 (542.3) | 9.00 (228.6) | 7.05 (179.1) |
| 2           | DN50/PN40              | 3.52 (89.4)     | 14.25 (362.0)  | 21.35 (542.3) | 9.00 (228.6) | 7.05 (179.1) |
| 2           | DN50/ PN100            | 4.30 (109.2)    | 14.25 (362.0)  | 21.35 (542.3) | 9.00 (228.6) | 7.05 (179.1) |
| 3           | 3 – 150#               | 4.63 (117.6)    | 17.50 (444.5)  | 24.60 (624.8) | 9.00 (228.6) | 7.55 (191.8) |
| 3           | 3 – 300#               | 5.00 (127.0)    | 17.50 (444.5)  | 24.60 (624.8) | 9.00 (228.6) | 7.93 (201.3) |
| 3           | 3 – 600#               | 5.38 (136.7)    | 17.50 (444.5)  | 24.60 (624.8) | 9.00 (228.6) | 7.93 (201.3) |
| 3           | DN80/PN16              | 3.85 (97.8)     | 17.50 (444.5)  | 24.60 (624.8) | 9.00 (228.6) | 7.93 (201.3) |
| 3           | DN80/PN40              | 4.16 (105.7)    | 17.50 (444.5)  | 24.60 (624.8) | 9.00 (228.6) | 7.93 (201.3) |
| 3           | DN80/ PN100            | 4.95 (125.7)    | 17.50 (444.5)  | 24.60 (624.8) | 9.00 (228.6) | 7.93 (201.3) |

Dimensions are in inches (millimeters)

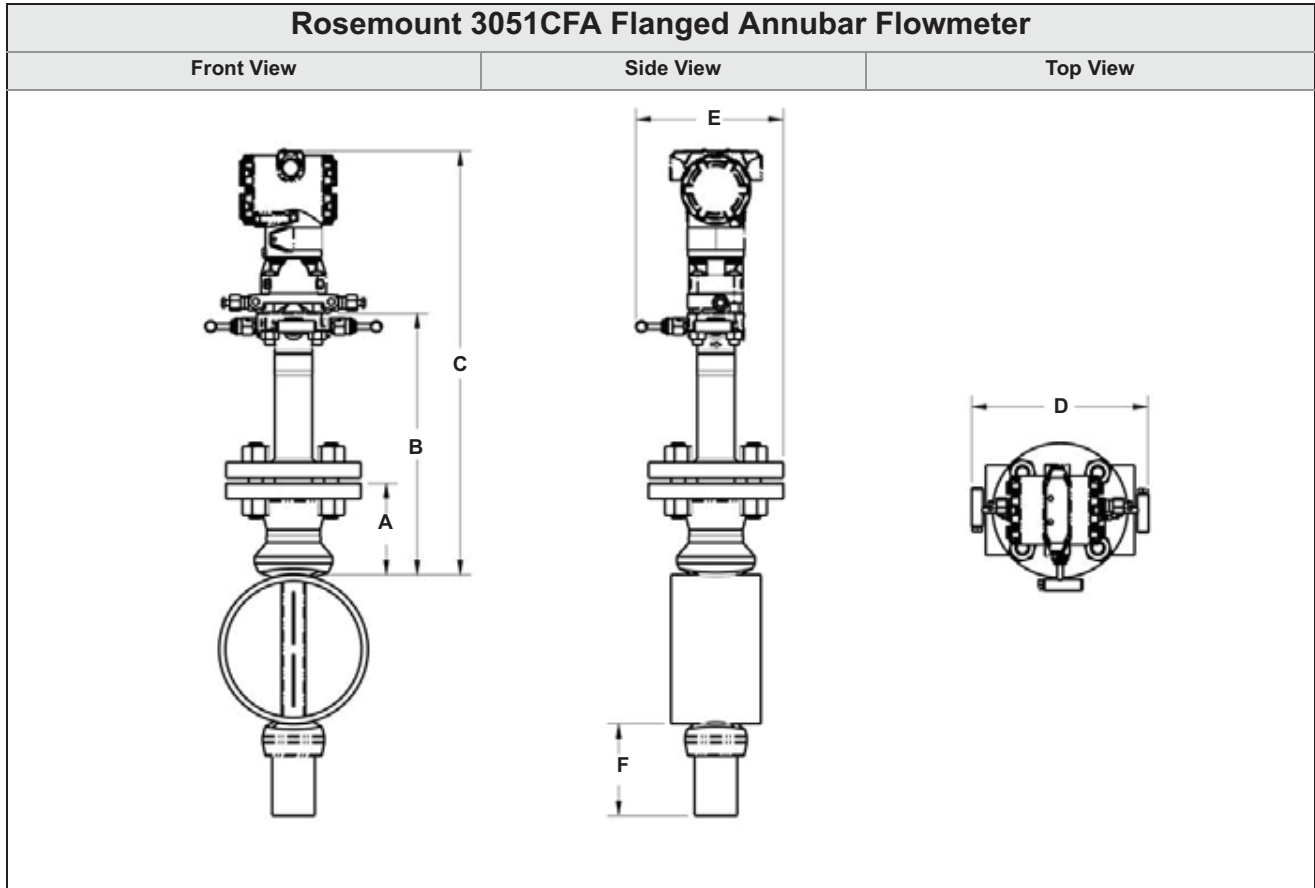

Table 15. 3051CFA Flanged Annubar Flowmeter Dimensional Data

| Sensor Size | Flange Size and Rating                | A ± 0.125 (3.2) | B ± 0.25 (6.4) | C ± 0.25 (6.4) | D (Max)      | E (Max)      | F (Max)      |
|-------------|---------------------------------------|-----------------|----------------|----------------|--------------|--------------|--------------|
| 1           | 1 <sup>1</sup> / <sub>2</sub> – 150#  | 3.88 (98.6)     | 11.00 (279.4)  | 18.10 (459.7)  | 9.00 (228.6) | 6.30 (160.0) | 3.50 (88.9)  |
| 1           | 1 <sup>1</sup> / <sub>2</sub> – 300#  | 4.13 (104.9)    | 11.00 (279.4)  | 18.10 (459.7)  | 9.00 (228.6) | 6.86 (174.2) | 3.50 (88.9)  |
| 1           | 1 <sup>1</sup> / <sub>2</sub> – 600#  | 4.44 (112.8)    | 11.00 (279.4)  | 18.10 (459.7)  | 9.00(228.6)  | 6.86 (174.2) | 3.50 (88.9)  |
| 1           | DN40/PN16                             | 3.09 (78.5)     | 11.00 (279.4)  | 18.10 (459.7)  | 9.00 (228.6) | 6.86 (174.2) | 3.50 (88.9)  |
| 1           | DN40/PN40                             | 3.21 (81.5)     | 11.00 (279.4)  | 18.10 (459.7)  | 9.00 (228.6) | 6.86 (174.2) | 3.50 (88.9)  |
| 1           | DN40/ PN100                           | 3.88 (98.6)     | 11.00 (279.4)  | 18.10 (459.7)  | 9.00(228.6)  | 6.86 (174.2) | 3.50 (88.9)  |
| 1           | 1 <sup>1</sup> / <sub>2</sub> – 900#  | 4.94 (125.5)    | 9.31 (236.5)   | —              | —            | —            | 3.50 (88.9)  |
| 1           | 1 <sup>1</sup> / <sub>2</sub> – 1500# | 4.94 (125.5)    | 9.31 (236.5)   | —              | —            | —            | 3.50 (88.9)  |
| 1           | 1 <sup>1</sup> / <sub>2</sub> – 2500# | 6.76 (171.7)    | 11.63 (295.4)  | —              | —            | —            | 4.00 (101.6) |
| 2           | 2 – 150#                              | 4.13 (104.9)    | 12.00 (304.8)  | 19.10 (458.1)  | 9.00 (228.6) | 6.80 (172.7) | 5.00 (127.0) |
| 2           | 2 – 300#                              | 4.38 (111.3)    | 12.00 (304.8)  | 19.10 (458.1)  | 9.00 (228.6) | 7.05 (179.1) | 5.00 (127.0) |
| 2           | 2 – 600#                              | 4.75 (120.7)    | 12.00 (304.8)  | 19.10 (458.1)  | 9.00 (228.6) | 7.05 (179.1) | 5.00 (127.0) |
| 2           | DN50/PN16                             | 3.40 (86.4)     | 12.00 (304.8)  | 19.10 (458.1)  | 9.00 (228.6) | 7.05 (179.1) | 5.00 (127.0) |
| 2           | DN50/PN40                             | 3.52 (89.4)     | 12.00 (304.8)  | 19.10 (458.1)  | 9.00 (228.6) | 7.05 (179.1) | 5.00 (127.0) |
| 2           | DN50/ PN100                           | 4.30 (109.3)    | 12.00 (304.8)  | 19.10 (458.1)  | 9.00 (228.6) | 7.05 (179.1) | 5.00 (127.0) |
| 2           | 2 – 900#                              | 5.88 (149.4)    | 10.50 (266.7)  | —              | —            | —            | 5.00 (127.0) |
| 2           | 2 – 1500#                             | 5.88 (149.4)    | 10.50 (266.7)  | —              | —            | —            | 5.00 (127.0) |
| 2           | 3 – 2500#                             | 9.88 (251.0)    | 15.63 (397.0)  | —              | —            | —            | 4.50 (114.3) |
| 3           | 3 – 150#                              | 4.63 (117.6)    | 13.50 (342.9)  | 20.60 (523.2)  | 9.00 (228.6) | 7.55 (191.8) | 4.00 (101.6) |
| 3           | 3 – 300#                              | 5.00 (127.0)    | 13.50 (342.9)  | 20.60 (523.2)  | 9.00 (228.6) | 7.93 (201.3) | 4.00 (101.6) |
| 3           | 3 – 600#                              | 5.38 (136.7)    | 13.50 (342.9)  | 20.60 (523.2)  | 9.00 (228.6) | 7.93 (201.3) | 4.00 (101.6) |

Table 15. 3051CFA Flanged Annubar Flowmeter Dimensional Data

| Sensor Size                                   | Flange Size and Rating | A ± 0.125 (3.2) | B ± 0.25 (6.4) | C ± 0.25 (6.4) | D (Max)      | E (Max)      | F (Max)      |
|---|------------------------|-----------------|----------------|----------------|--------------|--------------|--------------|
| 3   | DN80/PN16              | 3.85 (97.8)     | 13.50 (342.9)  | 20.60 (523.2)  | 9.00 (228.6) | 7.93 (201.3) | 4.00 (101.6) |
| 3   | DN80/PN40              | 4.16 (105.7)    | 13.50 (342.9)  | 20.60 (523.2)  | 9.00 (228.6) | 7.93 (201.3) | 4.00 (101.6) |
| 3   | DN80/ PN100            | 4.95 (125.7)    | 13.50 (342.9)  | 20.60 (523.2)  | 9.00 (228.6) | 7.93 (201.3) | 4.00 (101.6) |
| 3   | 4 – 900#               | 8.19 (208.0)    | 13.06 (331.8)  | —              | —            | —            | 7.00 (177.8) |
| 3   | 4 – 1500#              | 8.56 (217.4)    | 13.81 (350.8)  | —              | —            | —            | 7.00 (177.8) |
| 3   | 4 – 2500#              | 11.19 (284.2)   | 17.31 (439.7)  | —              | —            | —            | 7.00 (177.8) |
| <i>Dimensions are in inches (millimeters)</i> |                        |                 |                |                |              |              |              |

# Rosemount DP Flow

**Product Data Sheet**  
00813-1000-4485, Rev CA  
November 2011

## Rosemount 3051CFA Flanged Flo-Tap Annubar Flowmeter<sup>(1)</sup>

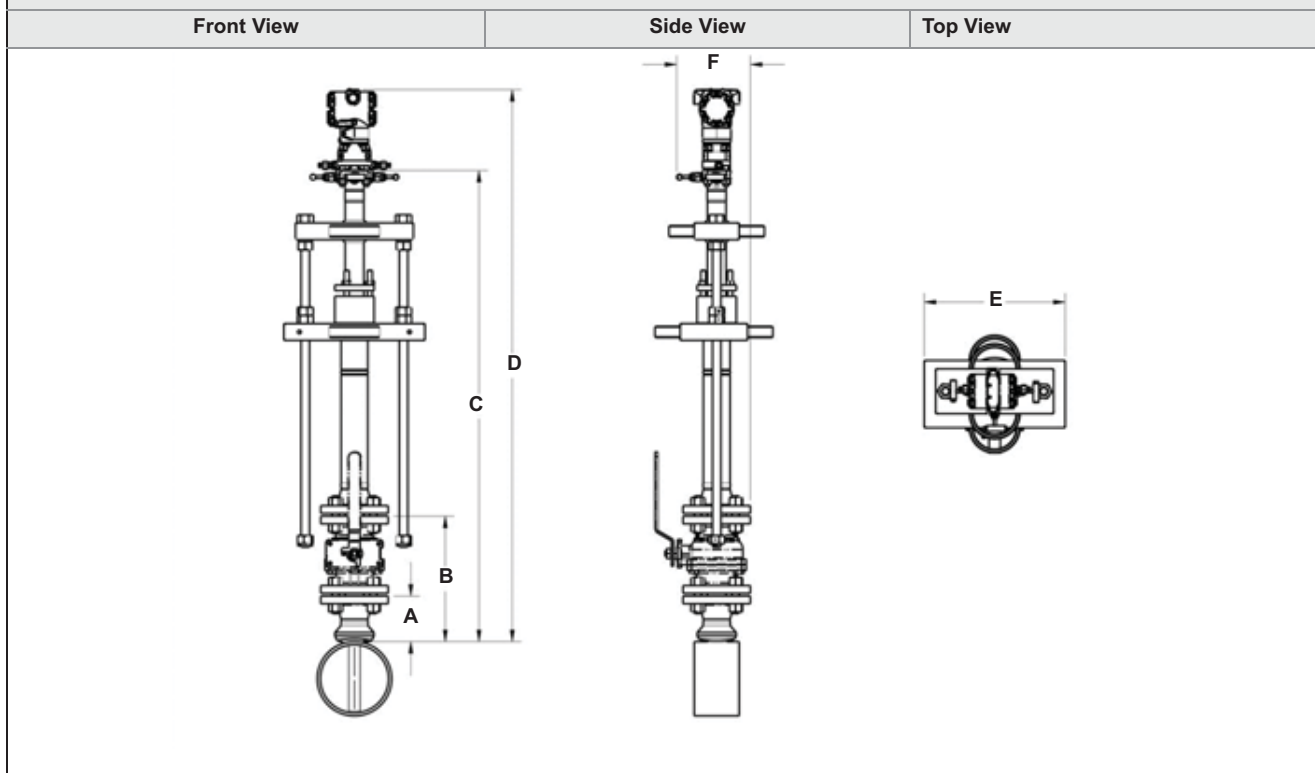

(1) The Flanged Flo-Tap Annubar Flowmeter is available with both the manual and gear drive options.

Table 16. 3051CFA Flanged Flo-Tap Annubar Flowmeter Dimensional Data

| Sensor Size | Flange Size and Rating   | A ± 0.125 (3.2) | B ± 0.25 (6.4) | C <sup>I</sup> (Max) (Gear Drive) | C <sup>I</sup> (Max) (Manual) | D (Max)          | E (Max)       | F (Max)      |
|-------------|--------------------------|-----------------|----------------|-----------------------------------|-------------------------------|------------------|---------------|--------------|
| 1           | 1½ – 150#                | 3.88 (98.6)     | 10.50 (266.7)  | —                                 | 17.77 (451.4)                 | C + 7.10 (180.3) | 10.50 (266.7) | 6.30 (160.0) |
| 1           | 1½ – 300#                | 4.13 (104.9)    | 11.75 (298.5)  | —                                 | 17.77 (451.4)                 | C + 7.10 (180.3) | 10.50 (266.7) | 6.86 (174.2) |
| 1           | 1½ – 600#                | 4.44 (112.8)    | 14.06 (357.2)  | —                                 | 17.77 (451.4)                 | C + 7.10 (180.3) | 10.50 (266.7) | 6.86 (174.2) |
| 1           | DN40/PN16 <sup>(1)</sup> | 3.09 (78.5)     | See Note 1.    | —                                 | 17.77 (451.4)                 | C + 7.10 (180.3) | 10.50 (266.7) | 6.86 (174.2) |
| 1           | DN40/PN40                | 3.21 (81.5)     | See Note 1.    | —                                 | 17.77 (451.4)                 | C + 7.10 (180.3) | 10.50 (266.7) | 6.86 (174.2) |
| 1           | DN40/PN100               | 3.88 (98.6)     | See Note 1.    | —                                 | 17.77 (451.4)                 | C + 7.10 (180.3) | 10.50 (266.7) | 6.86 (174.2) |
| 2           | 2 – 150#                 | 4.13 (104.9)    | 11.25 (285.8)  | 24.44 (620.8)                     | 21.20 (538.5)                 | C + 7.10 (180.3) | 12.56 (319.0) | 6.80 (172.7) |
| 2           | 2 – 300#                 | 4.38 (111.3)    | 13.00 (330.2)  | 24.44 (620.8)                     | 21.20 (538.5)                 | C + 7.10 (180.3) | 12.56 (319.0) | 7.05 (179.1) |
| 2           | 2 – 600#                 | 4.75 (120.7)    | 16.38 (416.0)  | 24.44 (620.8)                     | 21.20 (538.5)                 | C + 7.10 (180.3) | 12.56 (319.0) | 7.05 (179.1) |
| 2           | DN50/PN16                | 3.40 (86.4)     | See Note 1.    | 24.44 (620.8)                     | 21.20 (538.5)                 | C + 7.10 (180.3) | 12.56 (319.0) | 7.05 (179.1) |
| 2           | DN50/PN40                | 3.52 (89.4)     | See Note 1.    | 24.44 (620.8)                     | 21.20 (538.5)                 | C + 7.10 (180.3) | 12.56 (319.0) | 7.05 (179.1) |
| 2           | DN50/PN100               | 4.30 (109.2)    | See Note 1.    | 24.44 (620.8)                     | 21.20 (538.5)                 | C + 7.10 (180.3) | 12.56 (319.0) | 7.05 (179.1) |
| 3           | 3 – 150#                 | 4.63 (117.6)    | 12.75 (323.9)  | 26.37 (669.8)                     | 23.14 (587.8)                 | C + 7.10 (180.3) | 14.13 (358.9) | 7.55 (191.8) |
| 3           | 3 – 300#                 | 5.00 (127.0)    | 16.25 (412.8)  | 26.37 (669.8)                     | 23.14 (587.8)                 | C + 7.10 (180.3) | 14.13 (358.9) | 7.93 (201.3) |
| 3           | 3 – 600#                 | 5.38 (136.7)    | 19.50 (495.3)  | 26.37 (669.8)                     | 23.14 (587.8)                 | C + 7.10 (180.3) | 14.13 (358.9) | 7.93 (201.3) |
| 3           | DN80/PN16                | 3.85 (97.8)     | See Note 1.    | 26.37 (669.8)                     | 23.14 (587.8)                 | C + 7.10 (180.3) | 14.13 (358.9) | 7.93 (201.3) |
| 3           | DN80/PN40                | 4.16 (105.7)    | See Note 1.    | 26.37 (669.8)                     | 23.14 (587.8)                 | C + 7.10 (180.3) | 14.13 (358.9) | 7.93 (201.3) |
| 3           | DN80/PN100               | 4.95 (125.7)    | See Note 1.    | 26.37 (669.8)                     | 23.14 (587.8)                 | C + 7.10 (180.3) | 14.13 (358.9) | 7.93 (201.3) |

Dimensions are in inches (millimeters)

(1) DIN Valves are not offered.

**Note: Customer Supplied.**

Inserted, C Dimension = Pipe I.D. + Wall Thickness + B + C<sup>I</sup>

Retracted, C Dimension = 2 x (Pipe I.D. + Wall Thickness + B) + C<sup>I</sup>

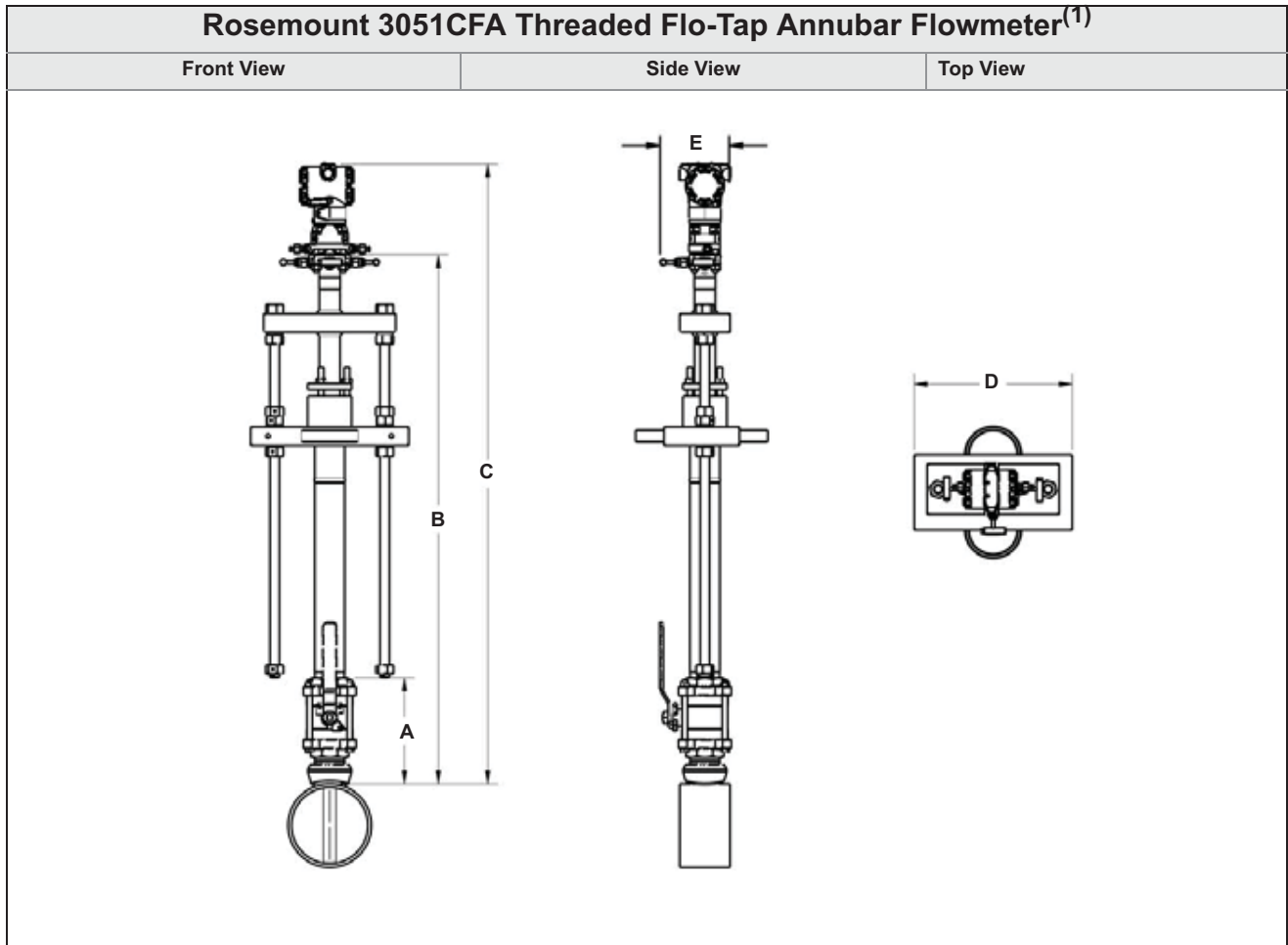

(1) The Threaded Flo-Tap Annubar Flowmeter is available with both the manual and gear drive options.

Table 17. 3051CFA Threaded Flo-Tap Annubar Flowmeter Dimensional Data

| Sensor Size  | A ± 0.50<br>(12.7) | B <sup>1</sup> (Max)<br>(Gear Drive) | B <sup>1</sup> (Max)<br>(Manual) | C (Max)          | D (Max)       | E (Max)      |
|--|--------------------|--------------------------------------|----------------------------------|------------------|---------------|--------------|
|  |                    |                                      |                                  | B + 7.10 (180.3) |               |              |
| 1  | 7.51 (190.9)       | —                                    | 16.96 (430.8)                    | B + 7.10 (180.3) | 10.50 (266.7) | 6.00 (152.4) |
| 2  | 8.17 (207.5)       | 23.62 (599.9)                        | 20.39 (517.9)                    | B + 7.10 (180.3) | 12.56 (319.0) | 6.00 (152.4) |
| <i>Sensor Size 3 is not available in a Threaded Flo-Tap.</i> |                    |                                      |                                  |                  |               |              |
| <i>Dimensions are in inches (millimeters)</i>                |                    |                                      |                                  |                  |               |              |

Inserted, B Dimension = Pipe I.D. + Wall Thickness + A + B<sup>1</sup>  
 Retracted, B Dimension = 2 x (Pipe I.D. + Wall Thickness + A) + B<sup>1</sup>

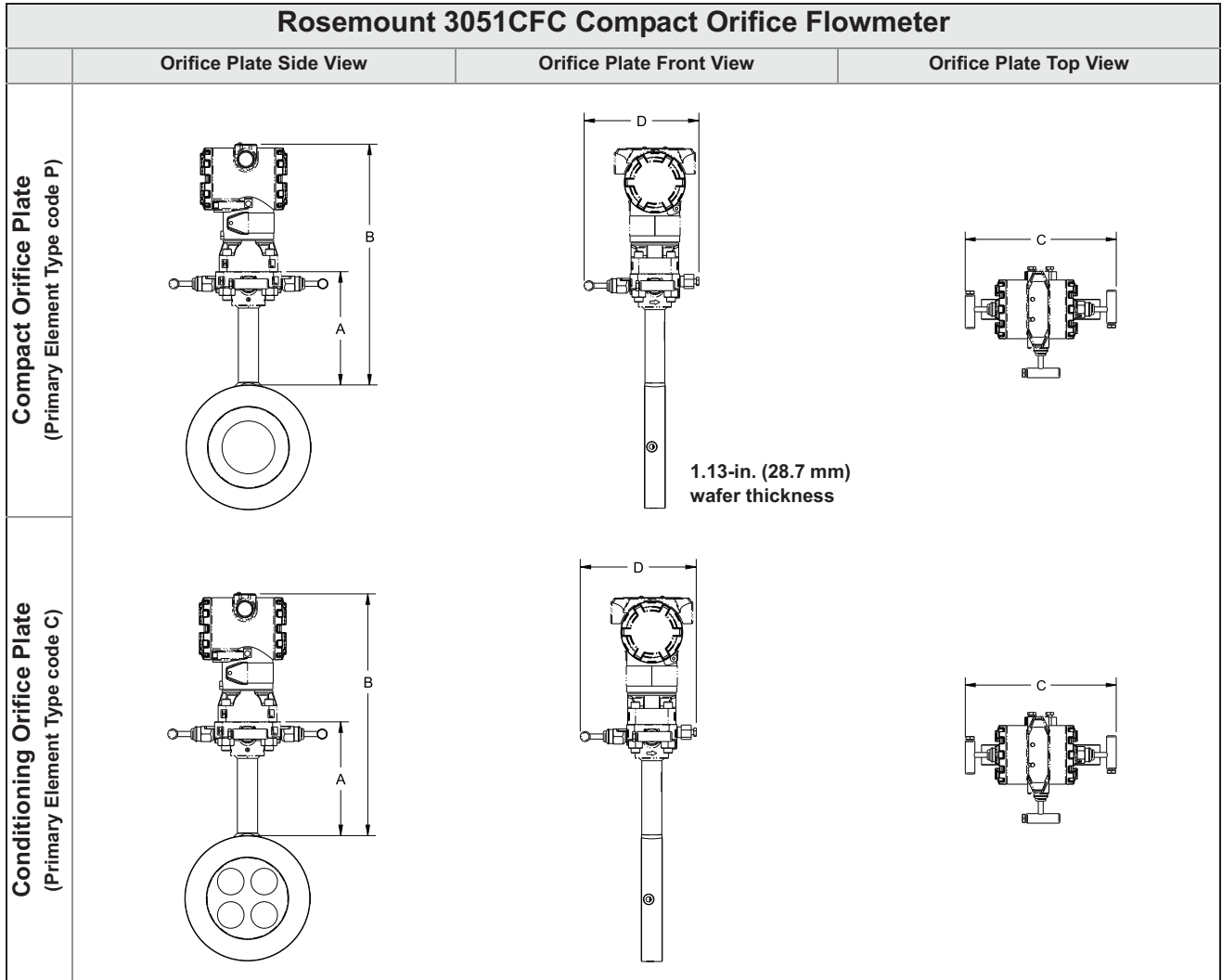

Table 18. 3051CFC Compact Orifice Dimensional Data<sup>(1)</sup>

| Primary Element Type | A          | B                      | Transmitter Height | C  | D  |
|----------------------|------------|------------------------|--------------------|--|--|
| Type P and C         | 5.62 (143) | Transmitter Height + A | 6.27 (159)         | 7.75 (197) - closed<br>8.25 (210) - open | 6.00 (152) - closed<br>6.25 (159) - open |

<sup>(1)</sup> Measurement in inches (millimeters).



# Rosemount DP Flow

**Product Data Sheet**  
00813-1000-4485, Rev CA  
November 2011

## 2051CF DIMENSIONAL DRAWINGS

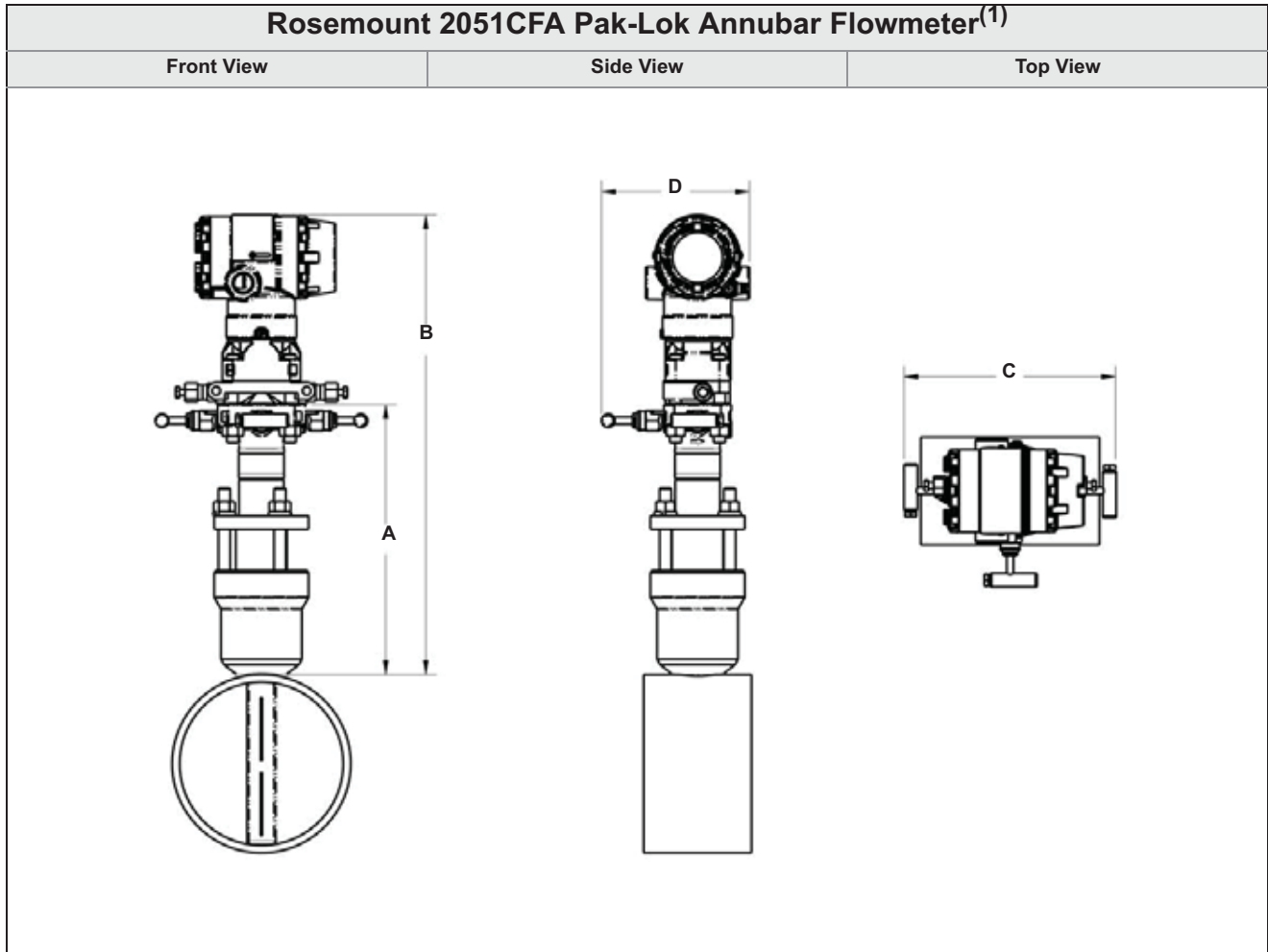

(1) The Pak-Lok Annubar model is available up to 600# ANSI (1440 psig at 100 °F (99 bar at 38 °C)).

Table 20. 2051CFA Pak-Lok Annubar Dimensional Data

| Sensor Size | A (Max)       | B (Max)       | C (Max)      | D (Max)      |
|-------------|---------------|---------------|--------------|--------------|
| 1           | 8.50 (215.9)  | 14.55 (369.6) | 9.00 (228.6) | 6.00 (152.4) |
| 2           | 11.00 (279.4) | 16.30 (414.0) | 9.00 (228.6) | 6.00 (152.4) |
| 3           | 12.00 (304.8) | 19.05 (483.9) | 9.00 (228.6) | 6.00 (152.4) |

*Dimensions are in inches (millimeters)*

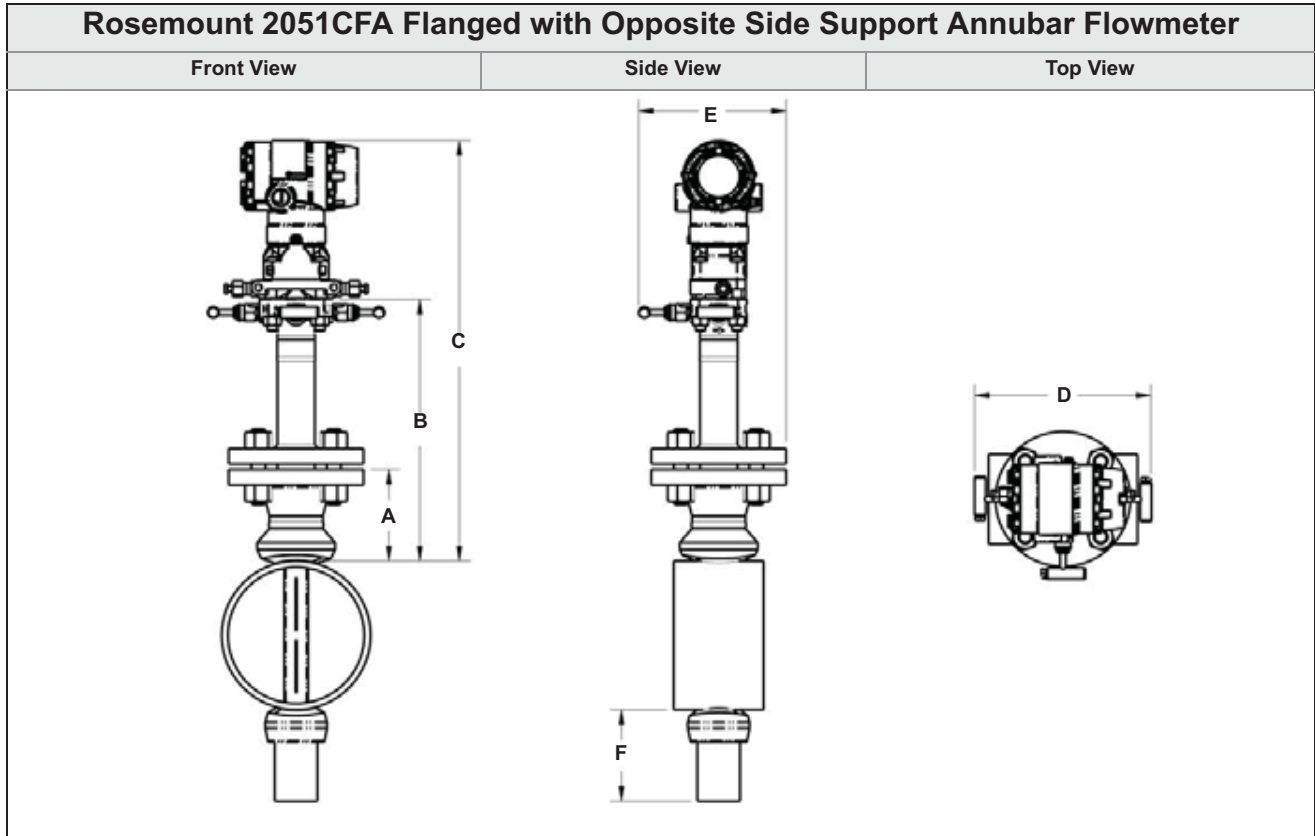

Table 21. 2051CFA Flanged Annubar Dimensional Data

| Sensor Size | Flange Size and Rating                | A ± 0.125 (3.2) | B ± 0.25 (6.4) | C ± 0.25 (6.4) | D (Max)      | E (Max)      | F (Max)      |
|-------------|---------------------------------------|-----------------|----------------|----------------|--------------|--------------|--------------|
| 1           | 1 <sup>1</sup> / <sub>2</sub> – 150#  | 3.88 (98.6)     | 11.00 (279.4)  | 18.03 (458.0)  | 9.00 (228.6) | 6.30 (160.0) | 3.50 (88.9)  |
| 1           | 1 <sup>1</sup> / <sub>2</sub> – 300#  | 4.13 (104.9)    | 11.00 (279.4)  | 18.03 (458.0)  | 9.00 (228.6) | 6.86 (174.2) | 3.50 (88.9)  |
| 1           | 1 <sup>1</sup> / <sub>2</sub> – 600#  | 4.44 (112.8)    | 11.00 (279.4)  | 18.03 (458.0)  | 9.00 (228.6) | 6.86 (174.2) | 3.50 (88.9)  |
| 1           | DN40/PN16                             | 3.09 (78.5)     | 11.00 (279.4)  | 18.03 (458.0)  | 9.00 (228.6) | 6.30 (160.0) | 3.50 (88.9)  |
| 1           | DN40/PN40                             | 3.21 (81.5)     | 11.00 (279.4)  | 18.03 (458.0)  | 9.00 (228.6) | 6.86 (174.2) | 3.50 (88.9)  |
| 1           | DN40/ PN100                           | 3.88 (98.6)     | 11.00 (279.4)  | 18.03 (458.0)  | 9.00 (228.6) | 6.86 (174.2) | 3.50 (88.9)  |
| 1           | 1 <sup>1</sup> / <sub>2</sub> – 900#  | 4.94 (125.5)    | 9.31 (236.5)   | -              | -            | -            | 3.50 (88.9)  |
| 1           | 1 <sup>1</sup> / <sub>2</sub> – 1500# | 4.94 (125.5)    | 9.31 (236.5)   | -              | -            | -            | 3.50 (88.9)  |
| 1           | 1 <sup>1</sup> / <sub>2</sub> – 2500# | 6.76 (171.7)    | 11.63 (295.4)  | -              | -            | -            | 4.00 (101.6) |
| 2           | 2 – 150#                              | 4.13 (104.9)    | 12.00 (304.8)  | 19.03 (483.4)  | 9.00 (228.6) | 6.30 (160.0) | 5.00 (127.0) |
| 2           | 2 – 300#                              | 4.38 (111.3)    | 12.00 (304.8)  | 19.03 (483.4)  | 9.00 (228.6) | 6.86 (174.2) | 5.00 (127.0) |
| 2           | 2 – 600#                              | 4.75 (120.7)    | 12.00 (304.8)  | 19.03 (483.4)  | 9.00 (228.6) | 6.86 (174.2) | 5.00 (127.0) |
| 2           | DN50/PN16                             | 3.40 (86.4)     | 12.00 (304.8)  | 19.03 (483.4)  | 9.00 (228.6) | 6.30 (160.0) | 5.00 (127.0) |
| 2           | DN50/PN40                             | 3.52 (89.4)     | 12.00 (304.8)  | 19.03 (483.4)  | 9.00 (228.6) | 6.86 (174.2) | 5.00 (127.0) |
| 2           | DN50/ PN100                           | 4.30 (109.2)    | 12.00 (304.8)  | 19.03 (483.4)  | 9.00 (228.6) | 6.86 (174.2) | 5.00 (127.0) |
| 2           | 2 – 900#                              | 5.88 (149.4)    | 10.50 (266.7)  | -              | -            | -            | 5.00 (127.0) |
| 2           | 2 – 1500#                             | 5.88 (149.4)    | 10.50 (266.7)  | -              | -            | -            | 5.00 (127.0) |
| 2           | 2 – 2500#                             | 9.88 (251.0)    | 15.63 (397.0)  | -              | -            | -            | 4.50 (114.3) |
| 3           | 3 – 150#                              | 4.63 (117.6)    | 13.50 (342.9)  | 20.53 (521.5)  | 9.00 (228.6) | 6.30 (160.0) | 4.00 (101.6) |
| 3           | 3 – 300#                              | 5.00 (127.0)    | 13.50 (342.9)  | 20.53 (521.5)  | 9.00 (228.6) | 6.86 (174.2) | 4.00 (101.6) |
| 3           | 3 – 600#                              | 5.38 (136.7)    | 13.50 (342.9)  | 20.53 (521.5)  | 9.00 (228.6) | 6.86 (174.2) | 4.00 (101.6) |

# Rosemount DP Flow

**Product Data Sheet**  
00813-1000-4485, Rev CA  
November 2011

Table 21. 2051CFA Flanged Annubar Dimensional Data

| Sensor Size | Flange Size and Rating | A ± 0.125 (3.2) | B ± 0.25 (6.4) | C ± 0.25 (6.4) | D (Max)      | E (Max)      | F (Max)      |
|-------------|------------------------|-----------------|----------------|----------------|--------------|--------------|--------------|
| 3           | DN80/PN16              | 3.85 (97.8)     | 13.50 (342.9)  | 20.53 (521.5)  | 9.00 (228.6) | 6.30 (160.0) | 4.00 (101.6) |
| 3           | DN80/PN40              | 4.16 (105.7)    | 13.50 (342.9)  | 20.53 (521.5)  | 9.00 (228.6) | 6.86 (174.2) | 4.00 (101.6) |
| 3           | DN80/ PN100            | 4.95 (125.7)    | 13.50 (342.9)  | 20.53 (521.5)  | 9.00 (228.6) | 6.86 (174.2) | 4.00 (101.6) |
| 3           | 3 – 900#               | 8.19 (208.0)    | 13.06 (331.7)  | -              | -            | -            | 7.00 (177.8) |
| 3           | 3 – 1500#              | 8.56 (217.4)    | 13.81 (350.8)  | -              | -            | -            | 7.00 (177.8) |
| 3           | 3 – 2500#              | 11.19 (284.2)   | 17.31 (439.7)  | -              | -            | -            | 7.00 (177.8) |

*Dimensions are in inches (millimeters)*

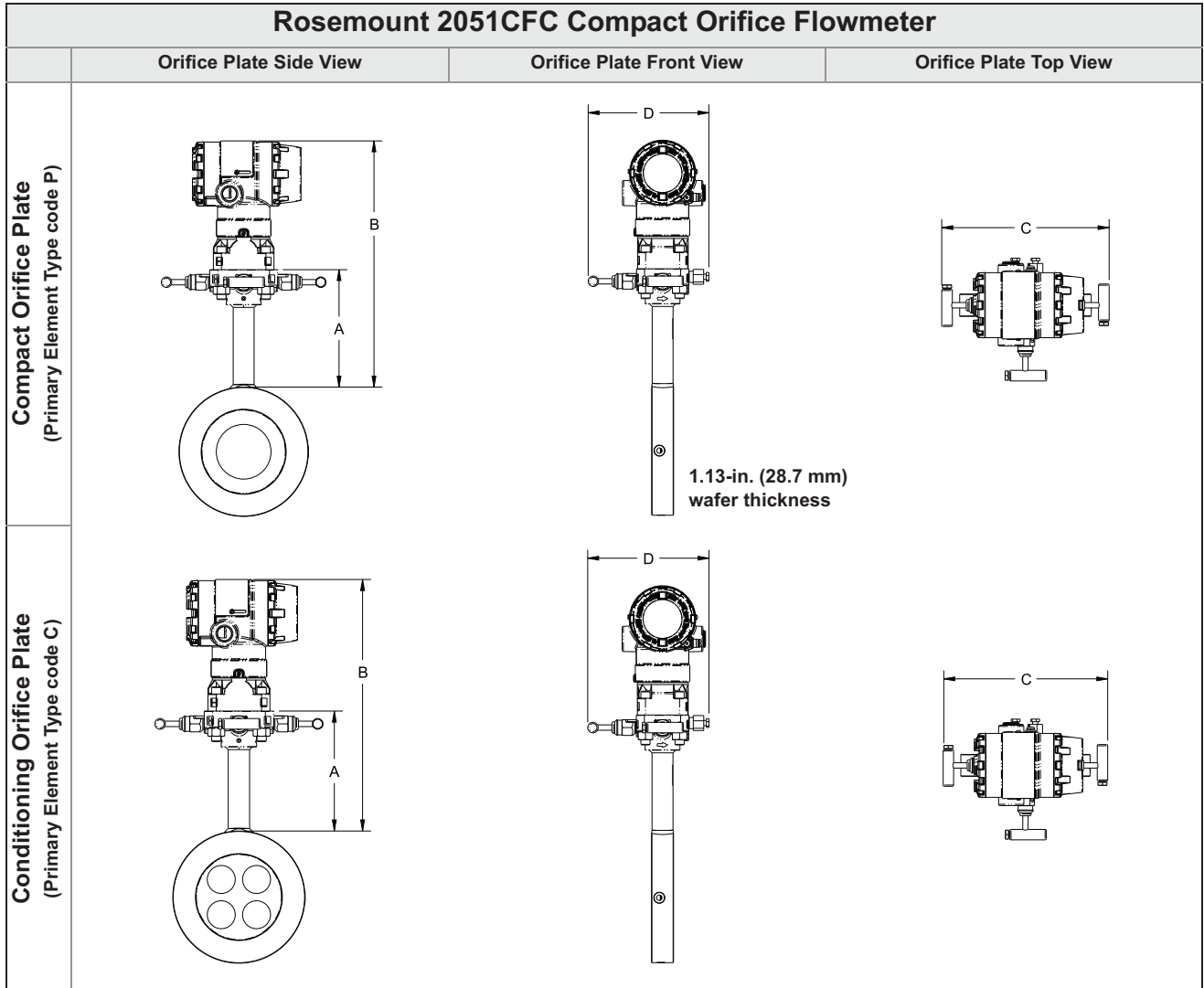

Table 22. 2051CFC Compact Orifice Dimensional Data<sup>(1)</sup>

| Primary Element Type | A          | B                      | Transmitter Height | C  | D  |
|----------------------|------------|------------------------|--------------------|--|--|
| Type P and C         | 5.62 (143) | Transmitter Height + A | 6.2 (157)          | 7.75 (197) - closed<br>8.25 (210) - open | 6.00 (152) - closed<br>6.25 (159) - open |

<sup>(1)</sup> Measurement in inches (millimeters).

# Rosemount DP Flow

**Product Data Sheet**  
00813-1000-4485, Rev CA  
November 2011

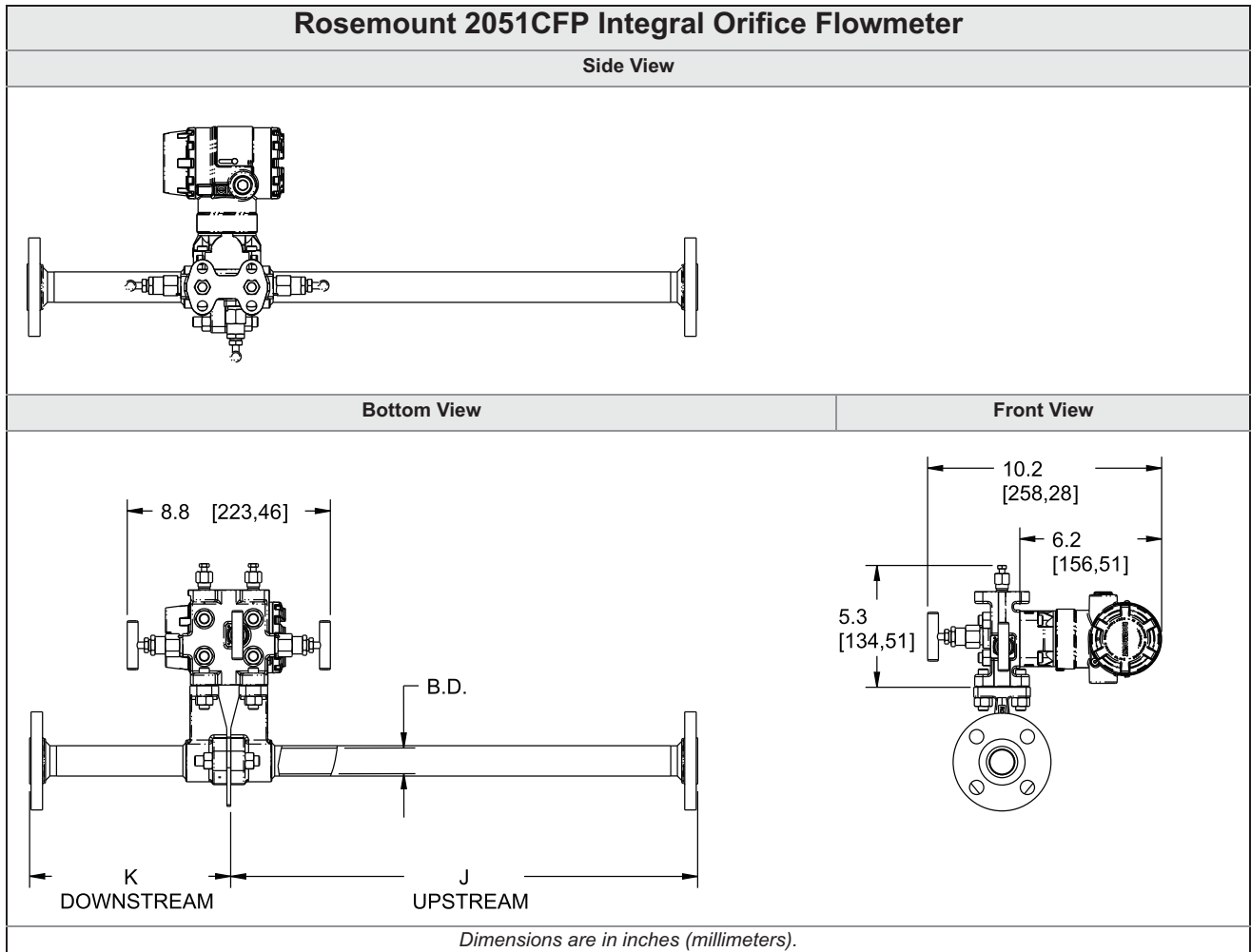

Table 23. 2051CFP Integral Orifice Dimensional Data

| Dimension  | Line Size       |               |                   |
|--|-----------------|---------------|-------------------|
|  | 1/2-in. (15 mm) | 1-in. (25 mm) | 1 1/2-in. (40 mm) |
| J (Beveled/Threaded pipe ends)                             | 12.54 (318.4)   | 20.24 (514.0) | 28.44 (722.4)     |
| J (RF slip-on, RTJ slip-on, RF-DIN slip on)                | 12.62 (320.4)   | 20.32 (516.0) | 28.52 (724.4)     |
| J (RF 150#, weld neck)                                     | 14.37 (364.9)   | 22.37 (568.1) | 30.82 (782.9)     |
| J (RF 300#, weld neck)                                     | 14.56 (369.8)   | 22.63 (574.7) | 31.06 (789.0)     |
| J (RF 600#, weld neck)                                     | 14.81 (376.0)   | 22.88 (581.0) | 31.38 (797.1)     |
| K (Beveled/Threaded pipe ends)                             | 5.74 (145.7)    | 8.75 (222.2)  | 11.91 (302.6)     |
| K (RF slip-on, RTJ slip-on, RF-DIN slip on) <sup>(1)</sup> | 5.82 (147.8)    | 8.83 (224.2)  | 11.99 (304.6)     |
| K (RF 150#, weld neck)                                     | 7.57 (192.3)    | 10.88 (276.3) | 14.29 (363.1)     |
| K (RF 300#, weld neck)                                     | 7.76 (197.1)    | 11.14 (282.9) | 14.53 (369.2)     |
| K (RF 600#, weld neck)                                     | 8.01 (203.4)    | 11.39 (289.2) | 14.85 (377.2)     |
| B.D. (Bore Diameter)                                       | 0.664 (16.87)   | 1.097 (27.86) | 1.567 (39.80)     |

Dimensions are in inches (millimeters).

(1) Downstream length shown here includes plate thickness of 0.162-in. (4.11 mm).

**485 DIMENSIONAL DRAWINGS**

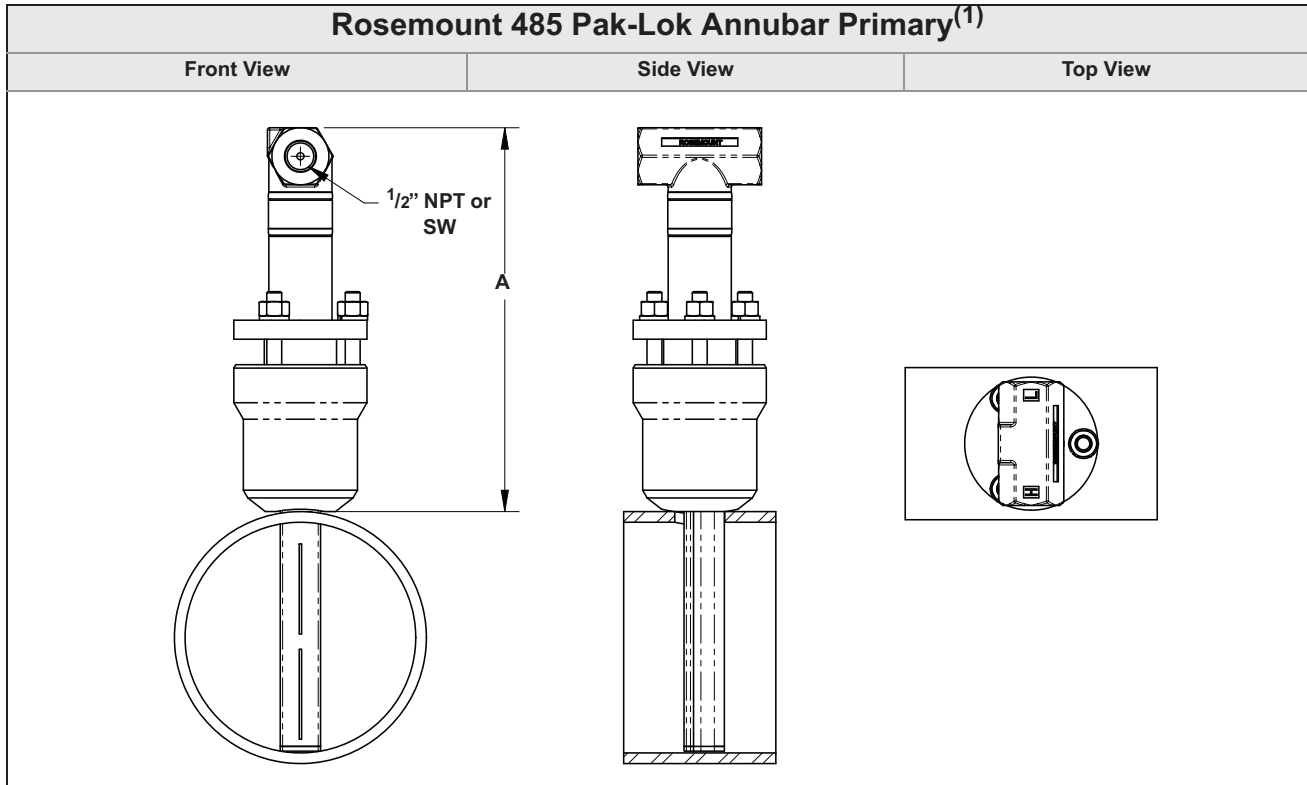

(1) The Pak-Lok Annubar model is available up to 600# ANSI (1440 psig at 100 °F (99 bar at 38 °C)).

Table 24. 485 Pak-Lok Annubar Primary Dimensional Data

| Sensor Size                                   | A (Max)       |
|---|---------------|
| 1   | 8.50 (215.9)  |
| 2   | 11.00 (279.4) |
| 3   | 12.00 (304.8) |
| <i>Dimensions are in inches (millimeters)</i> |               |

## Rosemount 485 Flange-Lok Annubar Primary<sup>(1)</sup>

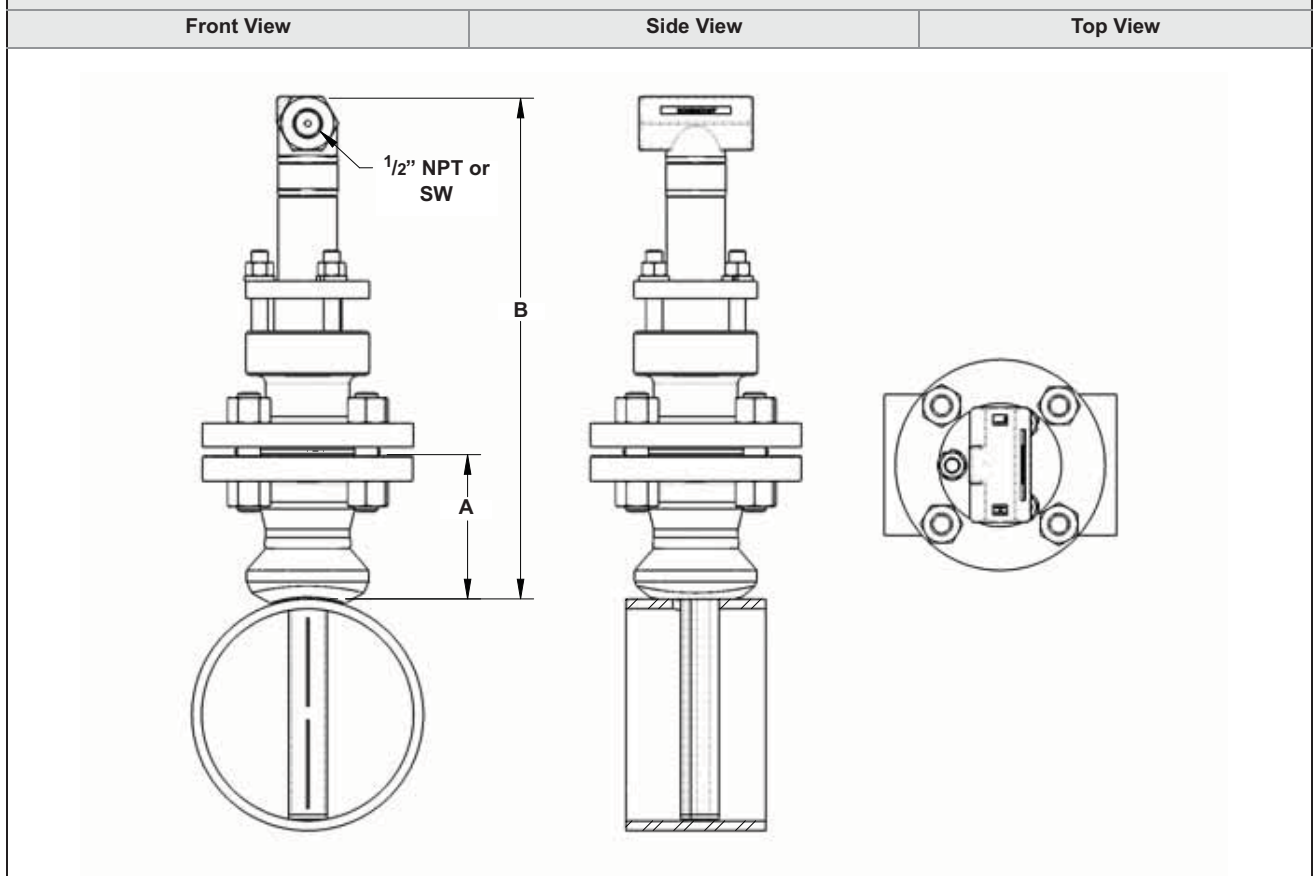

(1) The Flange-Lok Annubar model can be direct mounted up to 600# ANSI (1440 psig at 100 °F (99 bar at 38 °C)).

Table 25. 485 Flange-Lok Annubar Primary Dimensional Data

| Sensor Size | Flange Size and Rating | A ± 0.125 (3.2) | B ± 0.25 (6.4) |
|-------------|------------------------|-----------------|----------------|
| 1           | 1½ – 150#              | 3.88 (98.6)     | 12.25 (311.2)  |
| 1           | 1½ – 300#              | 4.13 (104.9)    | 12.25 (311.2)  |
| 1           | 1½ – 600#              | 4.44 (112.8)    | 12.25 (311.2)  |
| 1           | DN40/PN16              | 3.09 (78.5)     | 12.25 (311.2)  |
| 1           | DN40/PN40              | 3.21 (81.5)     | 12.25 (311.2)  |
| 1           | DN40/PN100             | 3.88 (98.6)     | 12.25 (311.2)  |
| 2           | 2 – 150#               | 4.13 (104.9)    | 14.25 (362.0)  |
| 2           | 2 – 300#               | 4.38 (111.3)    | 14.25 (362.0)  |
| 2           | 2 – 600#               | 4.75 (120.7)    | 14.25 (362.0)  |
| 2           | DN50/PN16              | 3.40 (86.4)     | 14.25 (362.0)  |
| 2           | DN50/PN40              | 3.52 (89.4)     | 14.25 (362.0)  |
| 2           | DN50/ PN100            | 4.30 (109.2)    | 14.25 (362.0)  |
| 3           | 3 – 150#               | 4.63 (117.6)    | 17.50 (444.5)  |
| 3           | 3 – 300#               | 5.00 (127.0)    | 17.50 (444.5)  |
| 3           | 3 – 600#               | 5.38 (136.7)    | 17.50 (444.5)  |
| 3           | DN80/PN16              | 3.85 (97.8)     | 17.50 (444.5)  |
| 3           | DN80/PN40              | 4.16 (105.7)    | 17.50 (444.5)  |
| 3           | DN80/ PN100            | 4.95 (125.7)    | 17.50 (444.5)  |

Dimensions are in inches (millimeters)

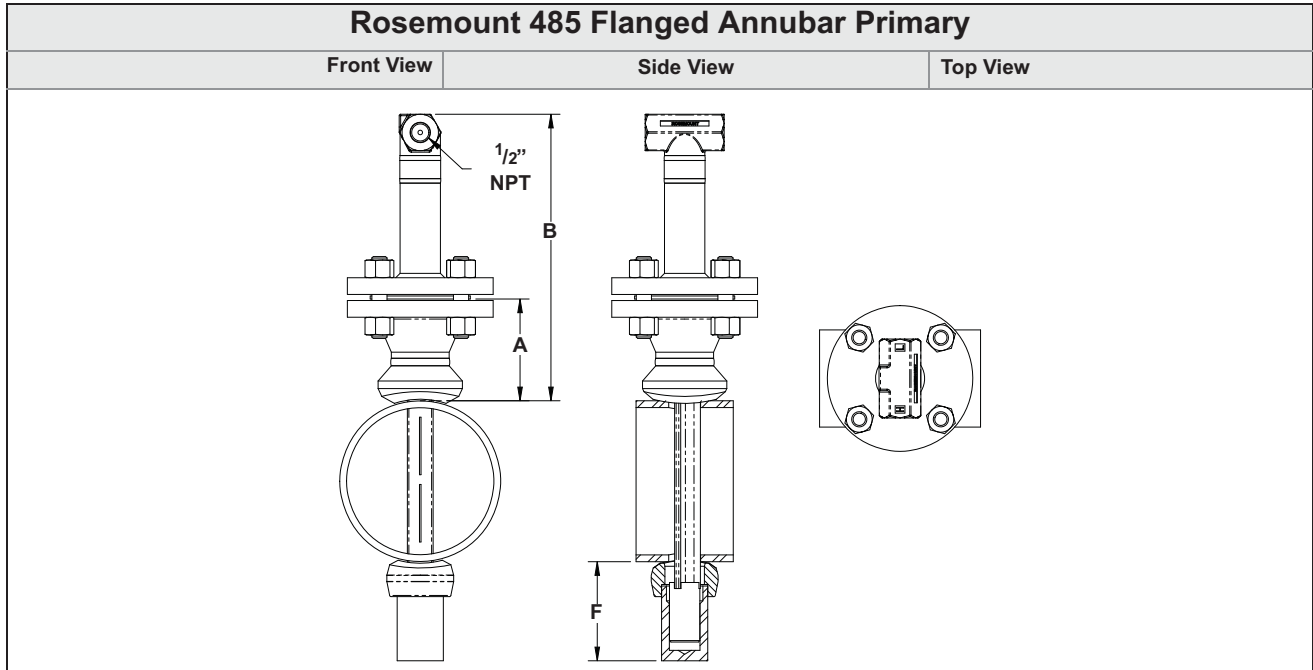

Table 26. 485 Flanged Annubar Primary Dimensional Data

| Sensor Size | Flange Size and Rating | A ± 0.125 (3.2) | B ± 0.25 (6.4) | F (Max)      |
|-------------|------------------------|-----------------|----------------|--------------|
| 1           | 1 1/2 – 150#           | 3.88 (98.6)     | 11.00 (279.4)  | 3.50 (88.9)  |
| 1           | 1 1/2 – 300#           | 4.13 (104.9)    | 11.00 (279.4)  | 3.50 (88.9)  |
| 1           | 1 1/2 – 600#           | 4.44 (112.8)    | 11.00 (279.4)  | 3.50 (88.9)  |
| 1           | DN40/PN16              | 3.09 (78.5)     | 11.00 (279.4)  | 3.50 (88.9)  |
| 1           | DN40/PN40              | 3.21 (81.5)     | 11.00 (279.4)  | 3.50 (88.9)  |
| 1           | DN40/ PN100            | 3.88 (98.6)     | 11.00 (279.4)  | 3.50 (88.9)  |
| 1           | 1 1/2 – 900#           | 4.94 (125.5)    | 9.31 (236.5)   | 3.50 (88.9)  |
| 1           | 1 1/2 – 1500#          | 4.94 (125.5)    | 9.31 (236.5)   | 3.50 (88.9)  |
| 1           | 1 1/2 – 2500#          | 6.76 (171.7)    | 11.63 (295.4)  | 4.00 (101.6) |
| 2           | 2 – 150#               | 4.13 (104.9)    | 12.00 (304.8)  | 5.00 (127.0) |
| 2           | 2 – 300#               | 4.38 (111.3)    | 12.00 (304.8)  | 5.00 (127.0) |
| 2           | 2 – 600#               | 4.75 (120.7)    | 12.00 (304.8)  | 5.00 (127.0) |
| 2           | DN50/PN16              | 3.40 (86.4)     | 12.00 (304.8)  | 5.00 (127.0) |
| 2           | DN50/PN40              | 3.52 (89.4)     | 12.00 (304.8)  | 5.00 (127.0) |
| 2           | DN50/ PN100            | 4.30 (109.2)    | 12.00 (304.8)  | 5.00 (127.0) |
| 2           | 2 – 900#               | 5.88 (149.4)    | 10.50 (266.7)  | 5.00 (127.0) |
| 2           | 2 – 1500#              | 5.88 (149.4)    | 10.50 (266.7)  | 5.00 (127.0) |
| 2           | 3 – 2500#              | 9.88 (251.0)    | 15.63 (397.0)  | 4.50 (114.3) |
| 3           | 3 – 150#               | 4.63 (117.6)    | 13.50 (342.9)  | 4.00 (101.6) |
| 3           | 3 – 300#               | 5.00 (127.0)    | 13.50 (342.9)  | 4.00 (101.6) |
| 3           | 3 – 600#               | 5.38 (136.7)    | 13.50 (342.9)  | 4.00 (101.6) |
| 3           | DN80/PN16              | 3.85 (97.8)     | 13.50 (342.9)  | 4.00 (101.6) |
| 3           | DN80/PN40              | 4.16 (105.7)    | 13.50 (342.9)  | 4.00 (101.6) |
| 3           | DN80/ PN100            | 4.95 (125.7)    | 13.50 (342.9)  | 4.00 (101.6) |
| 3           | 4 – 900#               | 8.19 (208.0)    | 13.06 (331.7)  | 7.00 (177.8) |
| 3           | 4 – 1500#              | 8.56 (217.4)    | 13.81 (350.8)  | 7.00 (177.8) |
| 3           | 4 – 2500#              | 11.19 (284.2)   | 17.31 (439.7)  | 7.00 (177.8) |

*Dimensions are in inches (millimeters)*

# Rosemount DP Flow

**Product Data Sheet**  
00813-1000-4485, Rev CA  
November 2011

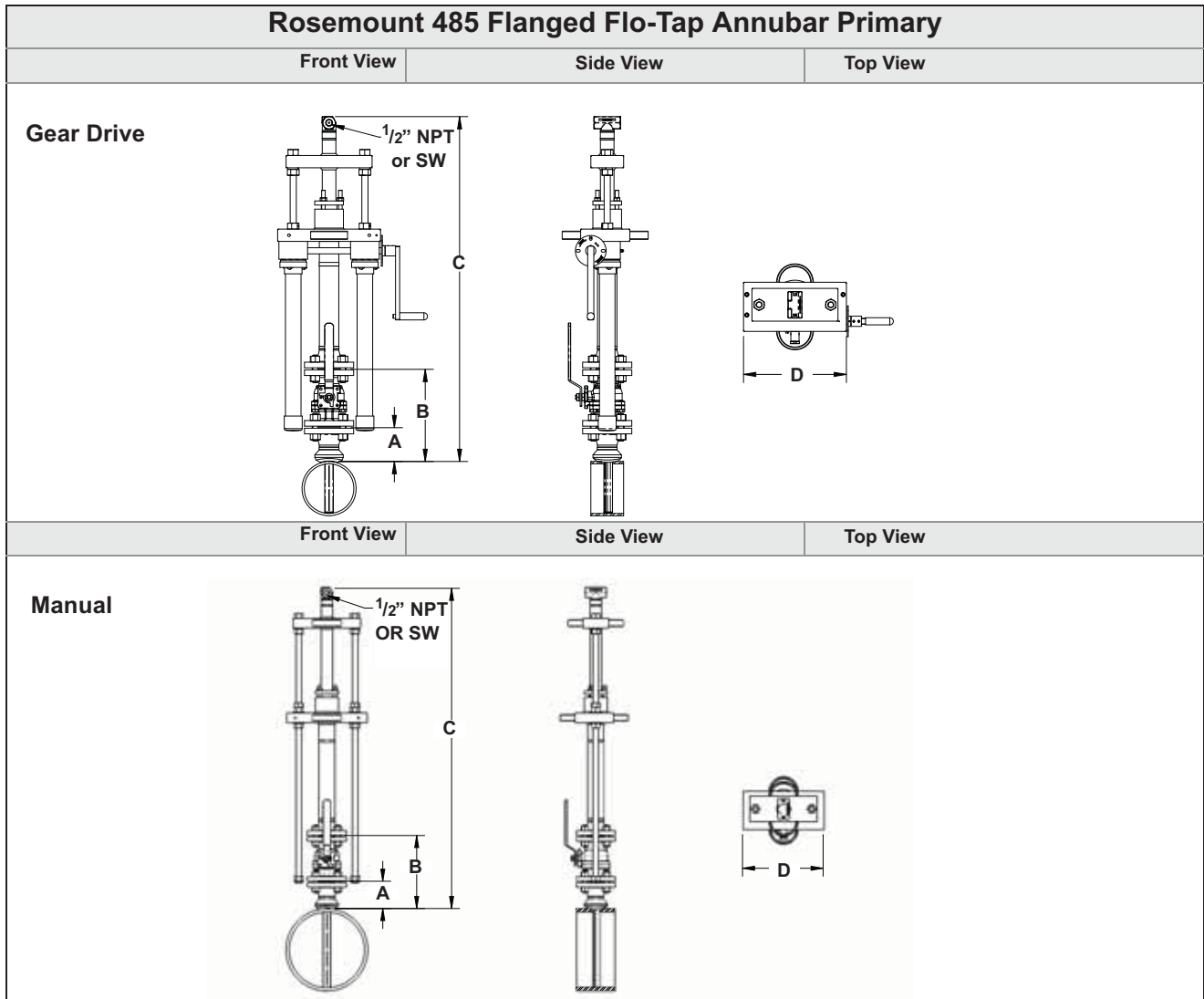

Table 27. 485 Flanged Flo-Tap Annubar Primary Dimensional Data

| Sensor Size | Flange Size and Rating | A ± 0.125 (3.2) | B ± 0.25 (6.4)          | C <sup>1</sup> (Max)<br>(Gear Drive) | C <sup>1</sup> (Max)<br>(Manual) | D (Max)       |
|-------------|------------------------|-----------------|-------------------------|--------------------------------------|----------------------------------|---------------|
| 1           | 1 1/2 – 150#           | 3.88 (98.6)     | 10.50 (266.7)           | —                                    | <b>17.77 (451.4)</b>             | 10.50 (266.7) |
| 1           | 1 1/2 – 300#           | 4.13 (104.9)    | 11.75 (298.5)           | —                                    | <b>17.77 (451.4)</b>             | 10.50 (266.7) |
| 1           | 1 1/2 – 600#           | 4.44 (112.8)    | 14.06 (357.2)           | —                                    | <b>17.77 (451.4)</b>             | 10.50 (266.7) |
| 1           | DN40/PN16              | 3.09 (78.5)     | See Note <sup>(1)</sup> | —                                    | <b>17.77 (451.4)</b>             | 10.50 (266.7) |
| 1           | DN40/PN40              | 3.21 (81.5)     | See Note <sup>(1)</sup> | —                                    | <b>17.77 (451.4)</b>             | 10.50 (266.7) |
| 1           | DN40/PN100             | 3.88 (98.6)     | See Note <sup>(1)</sup> | —                                    | <b>17.77 (451.4)</b>             | 10.50 (266.7) |
| 2           | 2 – 150#               | 4.13 (104.9)    | 11.25 (285.8)           | 24.44 (620.8)                        | 21.20 (538.5)                    | 12.56 (319.0) |
| 2           | 2 – 300#               | 4.38 (111.3)    | 13.00 (330.2)           | 24.44 (620.8)                        | 21.20 (538.5)                    | 12.56 (319.0) |
| 2           | 2 – 600#               | 4.75 (120.7)    | 16.38 (416.0)           | 24.44 (620.8)                        | 21.20 (538.5)                    | 12.56 (319.0) |
| 2           | DN50/PN16              | 3.40 (86.4)     | See Note <sup>(1)</sup> | 24.44 (620.8)                        | 21.20 (538.5)                    | 12.56 (319.0) |
| 2           | DN50/PN40              | 3.52 (89.4)     | See Note <sup>(1)</sup> | 24.44 (620.8)                        | 21.20 (538.5)                    | 12.56 (319.0) |
| 2           | DN50/PN100             | 4.30 (109.2)    | See Note <sup>(1)</sup> | 24.44 (620.8)                        | 21.20 (538.5)                    | 12.56 (319.0) |
| 3           | 3 – 150#               | 4.63 (117.6)    | 12.75 (323.9)           | 26.37 (669.8)                        | 23.14 (587.8)                    | 14.13 (358.9) |
| 3           | 3 – 300#               | 5.00 (127.0)    | 16.25 (412.8)           | 26.37 (669.8)                        | 23.14 (587.8)                    | 14.13 (358.9) |

**Product Data Sheet**

00813-1000-4485, Rev CA  
November 2011

**Rosemount DP Flow**

Table 27. 485 Flanged Flo-Tap Annubar Primary Dimensional Data

| Sensor Size  | Flange Size and Rating | A ± 0.125 (3.2) | B ± 0.25 (6.4)          | C <sup>1</sup> (Max) (Gear Drive) | C <sup>1</sup> (Max) (Manual) | D (Max)       |
|--|------------------------|-----------------|-------------------------|-----------------------------------|-------------------------------|---------------|
| 3  | 3 – 600#               | 5.38 (136.7)    | 19.50 (495.4)           | 26.37 (669.8)                     | 23.14 (587.8)                 | 14.13 (358.9) |
| 3  | DN80/PN16              | 3.85 (97.8)     | See Note <sup>(1)</sup> | 26.37 (669.8)                     | 23.14 (587.8)                 | 14.13 (358.9) |
| 3  | DN80/PN40              | 4.16 (105.7)    | See Note <sup>(1)</sup> | 26.37 (669.8)                     | 23.14 (587.8)                 | 14.13 (358.9) |
| 3  | DN80/PN100             | 4.95 (125.7)    | See Note <sup>(1)</sup> | 26.37 (669.8)                     | 23.14 (587.8)                 | 14.13 (358.9) |
| <p><b>Use the appropriate formula to determine C value:</b><br/> <i>Inserted formula:</i> Pipe I.D. + Wall Thickness + Value B + C<sup>1</sup> (use the Manual Drive or Gear drive values for C<sup>1</sup>)<br/> <i>Retracted formula:</i> [2 x (Pipe I.D. + Wall Thickness + Value B)] + C<sup>1</sup> (use the Manual Drive or Gear drive values for C<sup>1</sup>)</p> |                        |                 |                         |                                   |                               |               |
| <i>Dimensions are in inches (millimeters)</i>  |                        |                 |                         |                                   |                               |               |

(1) DIN Valves are not offered.

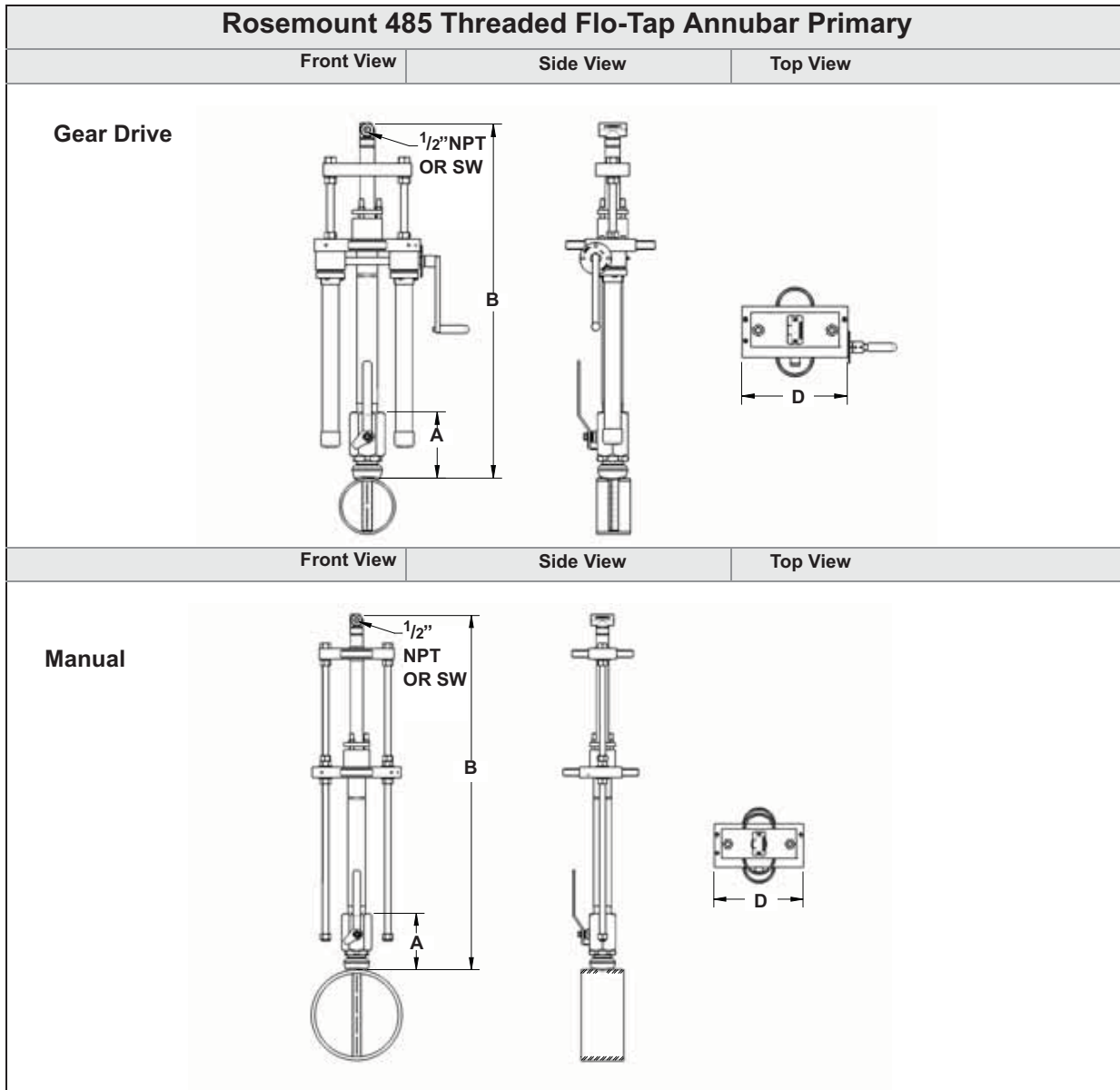

Table 28. 485 Threaded Flo-Tap Annubar Primary Dimensional Data

| Sensor Size | A ± 0.50<br>(12.7) | B <sup>1</sup> (Max)<br>(Gear Drive) | B <sup>1</sup> (Max)<br>(Manual) | D (Max)       |
|-------------|--------------------|--------------------------------------|----------------------------------|---------------|
| 1           | 7.51 (190.9)       | —                                    | 16.96 (430.8)                    | 10.50 (266.7) |
| 2           | 8.17 (207.5)       | 23.62 (599.9)                        | 20.39 (517.9)                    | 12.56 (319.0) |

*Sensor Size 3 is not available in a Threaded Flo-Tap.*

Inserted, B Dimension = Pipe I.D. + Wall Thickness + A + B<sup>1</sup>  
Retracted, B Dimension = 2 x (Pipe I.D. + Wall Thickness + A) + B<sup>1</sup>

**585 DIMENSIONAL DRAWINGS**

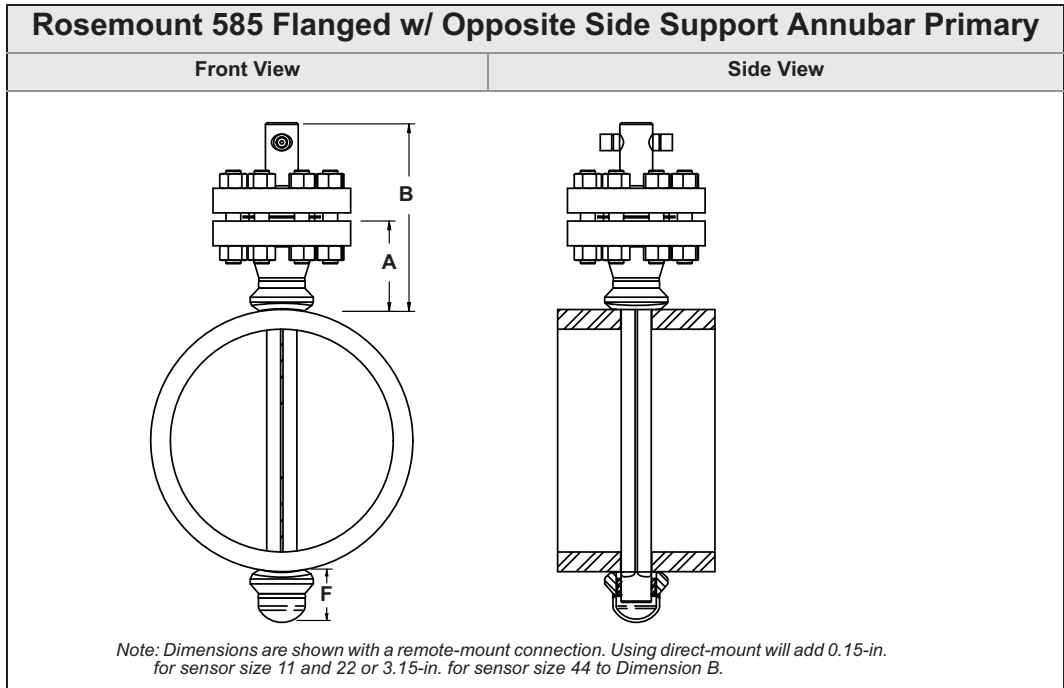

Table 29. 585 Flanged w/ Opposite Side Support Annubar Dimensional Data

| Sensor Size | Flange Size and Rating | A ± 0.125 (3.2) | B ± 0.25 (6.4) | F (Max)      |
|-------------|------------------------|-----------------|----------------|--------------|
| 11          | 1 1/2-in. – 150#       | 3.88 (98.6)     | 9.70 (246.4)   | 3.10 (78.7)  |
| 11          | 1 1/2-in. – 300#       | 4.13 (104.9)    | 10.07 (255.8)  | 3.10 (78.7)  |
| 11          | 1 1/2-in. – 600#       | 4.44 (112.8)    | 10.70 (271.8)  | 3.10 (78.7)  |
| 11          | DIN40/PN16             | 3.21 (81.5)     | 9.05 (229.9)   | 3.10 (78.7)  |
| 11          | DIN40/PN40             | 3.21 (81.5)     | 9.05 (229.9)   | 3.10 (78.7)  |
| 11          | DIN40/ PN100           | 3.88 (98.6)     | 10.03 (254.8)  | 3.10 (78.7)  |
| 11          | 1 1/2-in. – 900#       | 4.94 (125.5)    | 11.57 (293.9)  | 3.60 (91.4)  |
| 11          | 1 1/2-in. – 1500#      | 4.94 (125.5)    | 11.57 (293.9)  | 3.60 (91.4)  |
| 11          | 1 1/2-in. – 2500#      | 6.75 (171.5)    | 13.88 (352.6)  | 3.60 (91.4)  |
| 22          | 2-in. – 150#           | 4.13 (104.9)    | 10.01 (254.3)  | 4.50 (114.3) |
| 22          | 2-in. – 300#           | 4.38 (111.3)    | 10.38 (263.7)  | 4.50 (114.3) |
| 22          | 2-in. – 600#           | 4.75 (120.7)    | 11.13 (282.7)  | 4.50 (114.3) |
| 22          | DIN50/PN16             | 3.40 (86.4)     | 9.24 (234.7)   | 4.50 (114.3) |
| 22          | DIN50/PN40             | 3.52 (89.4)     | 9.44 (239.8)   | 4.50 (114.3) |
| 22          | DIN50/ PN100           | 4.30 (109.2)    | 10.53 (267.5)  | 4.50 (114.3) |
| 22          | 2-in. – 900#           | 5.88 (149.4)    | 12.76 (324.1)  | 4.50 (114.3) |
| 22          | 2-in. – 1500#          | 5.88 (149.4)    | 12.76 (324.1)  | 4.50 (114.3) |
| 22          | 3-in. – 2500#          | 9.88 (250.1)    | 17.88 (454.2)  | 4.50 (114.3) |
| 44          | 3-in. – 150#           | 4.63 (117.6)    | 10.69 (271.5)  | 3.90 (99.1)  |
| 44          | 3-in. – 300#           | 5.00 (127.0)    | 11.26 (286.6)  | 3.90 (99.1)  |
| 44          | 3-in. – 600#           | 5.38 (136.7)    | 12.00 (304.8)  | 3.90 (99.1)  |
| 44          | DIN80/PN16             | 3.85 (97.8)     | 9.77 (248.2)   | 3.90 (99.1)  |
| 44          | DIN80/PN40             | 4.16 (105.7)    | 10.23 (259.8)  | 3.90 (99.1)  |
| 44          | DIN80/ PN100           | 4.95 (125.7)    | 11.34 (288.8)  | 3.90 (99.1)  |
| 44          | 4-in. – 900#           | 8.19 (208.8)    | 15.32 (389.1)  | 6.40 (162.6) |
| 44          | 4-in. – 1500#          | 8.56 (217.4)    | 16.07 (408.2)  | 6.40 (162.6) |
| 44          | 4-in. – 2500#          | 11.19 (284.2)   | 19.57 (497.1)  | 6.40 (162.6) |

*Dimensions are in inches (millimeters)*

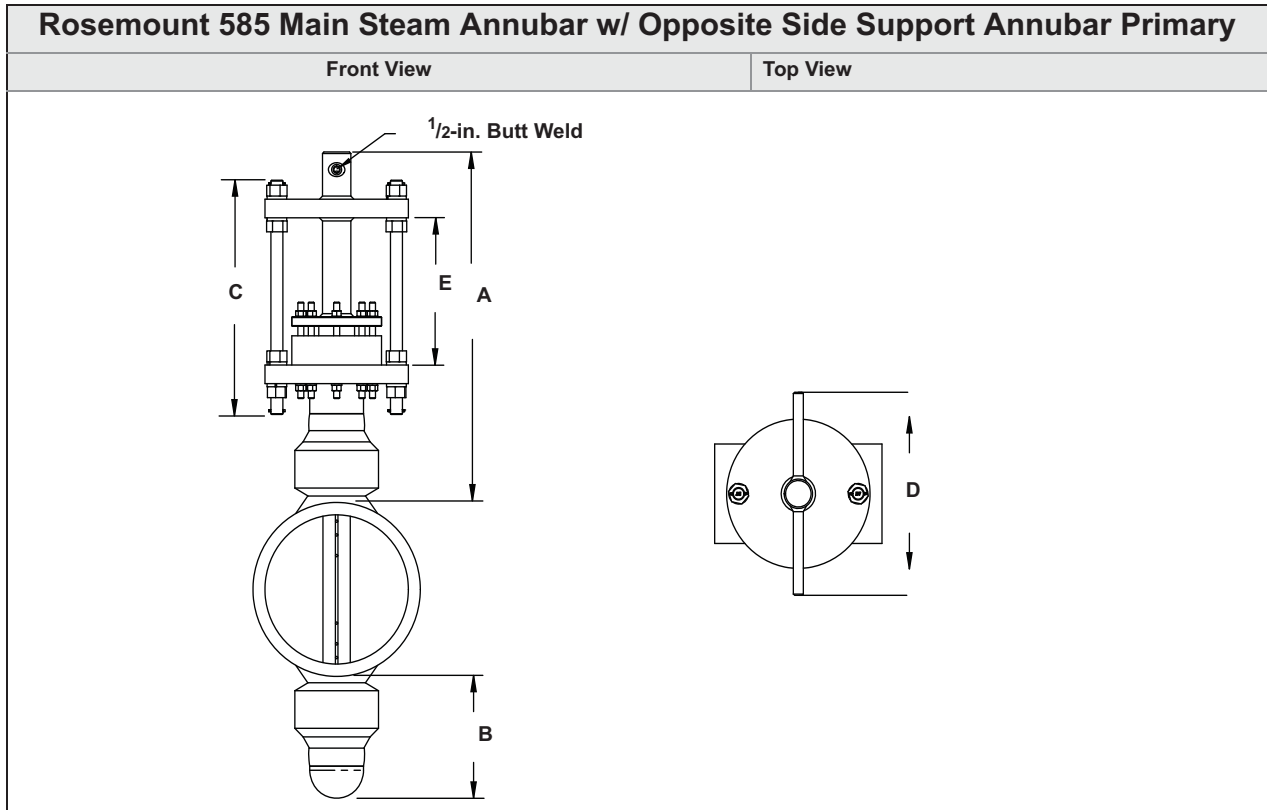

Table 30. 585 Main Steam Annubar w/ Opposite Side Support Annubar Dimensional Data

| Sensor Size                                   | A (Max)       | B          | C          | D             | E          |
|---|---------------|------------|------------|---------------|------------|
| 44  | 29.67 (753.6) | 10.0 (254) | 19.0 (483) | 16.33 (414.0) | 11.0 (279) |
| <i>Dimensions are in inches (millimeters)</i> |               |            |            |               |            |

**NOTE**

Locking rods are always located 90° from the instrument connections. For horizontal installations, the instrument connections will be parallel to the pipe. For vertical installations, the instrument connections will be perpendicular to the pipe.

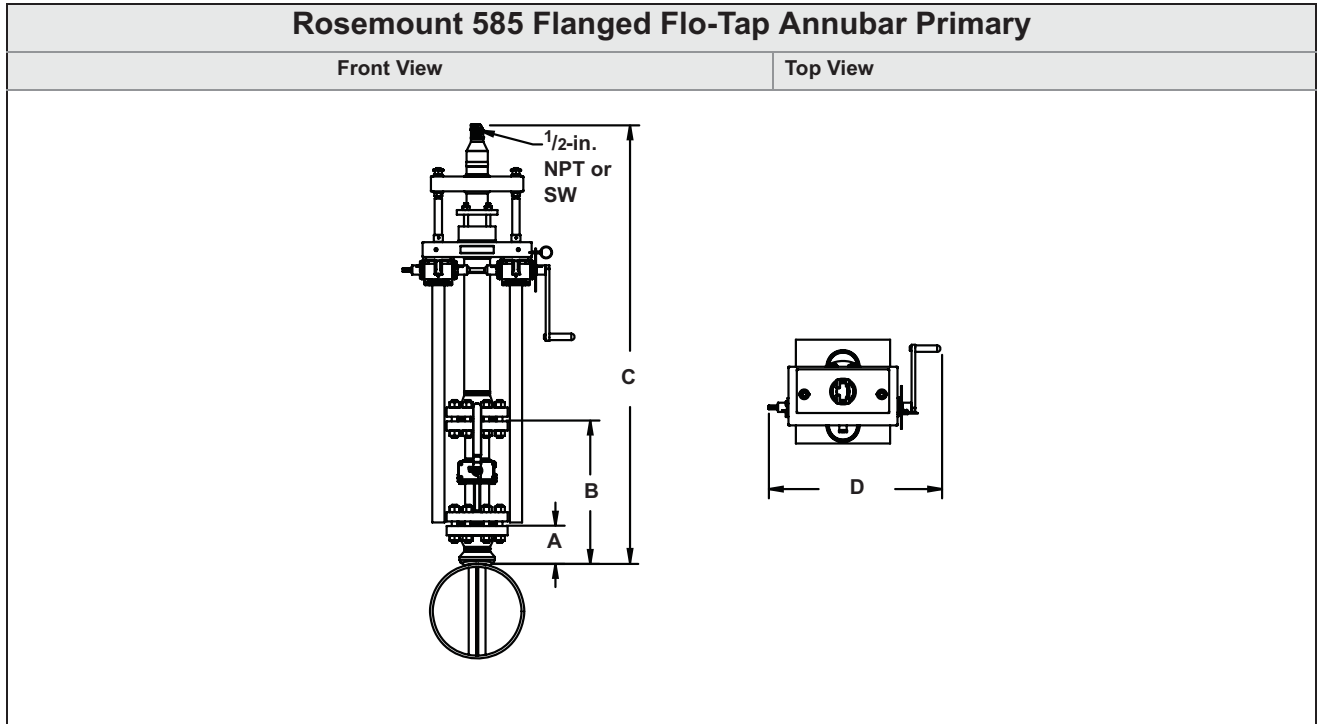

Table 31. 585 Flanged Flo-Tap Annubar Primary Dimensional Data

| Sensor Size   | Flange Size and Rating | A ± 0.125 (3.2) | B ± 0.25 (6.4) | C <sup>1</sup> (Max)<br>(Gear Drive) | D (Max)      |
|---|------------------------|-----------------|----------------|--------------------------------------|--------------|
| 44  | 3 – 150#               | 4.63 (117,6)    | 12.75 (323,9)  | 25.58 (649.7)                        | 23.3 (591,8) |
| 44  | 3 – 300#               | 5.00 (127,0)    | 16.25 (412,8)  | 25.58 (649.7)                        | 23.3 (591,8) |
| 44  | 3 – 600#               | 5.38 (136,7)    | 19.50 (495,4)  | 25.58 (649.7)                        | 23.3 (591,8) |
| <p><b>Use the appropriate formula to determine C value:</b><br/> <i>Inserted formula:</i> Pipe I.D. + Wall Thickness + Value B + C<sup>1</sup> (use the Gear drive values for C<sup>1</sup>)<br/> <i>Retracted formula:</i> [2 x (Pipe I.D. + Wall Thickness + Value B)] + C<sup>1</sup> (use the Gear drive values for C<sup>1</sup>)</p> <p style="text-align: center;"><i>Dimensions are in inches (millimeters)</i></p> |                        |                 |                |                                      |              |

## 405 DIMENSIONAL DRAWINGS

| Rosemount 405 Compact Orifice Plate<br>(Direct Mount)              |  |  |
|--|--|--|
|  | Front View (transmitter connection A3) | Front View (transmitter connection D3) |
| <b>Compact Orifice Plate</b><br>(Primary Element Type code P)      |  |  |
| <b>Conditioning Orifice Plate</b><br>(Primary Element Type code C) |  |  |

**NOTE**

Transmitter connection code A3 is to be used with a traditional style transmitter. This is a stainless steel adapter plate for allowing the direct mount of traditional style transmitters.

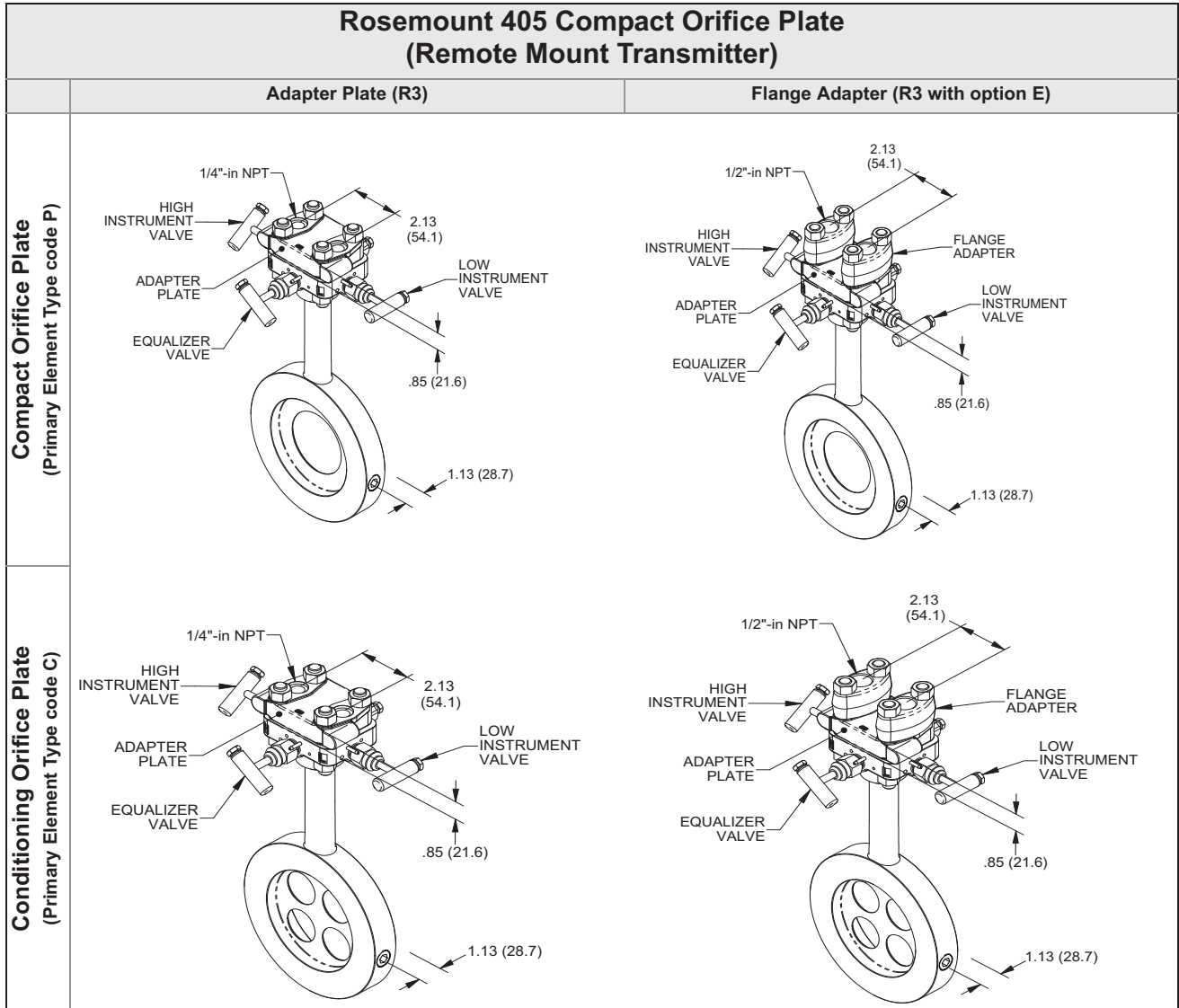

## 1595 DIMENSIONAL DRAWINGS

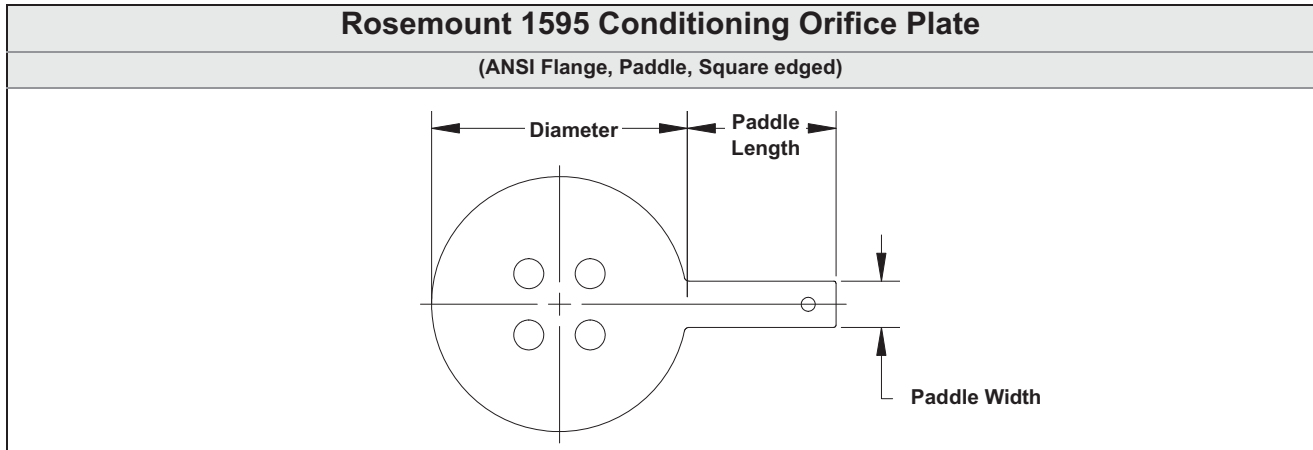

Table 32. Paddle Type Orifice Plate Dimensions in inches (millimeters)

| Line Size          | Diameter for Paddle Type |                     |                     |                     |                     |                     | Paddle Length  | Paddle Width  |
|--------------------|--------------------------|---------------------|---------------------|---------------------|---------------------|---------------------|----------------|---------------|
|                    | 150#                     | 300#                | 600#                | 900#                | 1500#               | 2500#               |                |               |
| 2-in.<br>(50 mm)   | 4.125<br>(104.78)        | 4.375<br>(111.13)   | 4.375<br>(111.13)   | 5.625<br>(142.875)  | 5.625<br>(142.875)  | 5.750<br>(146.050)  | 4.0<br>(101.6) | 1.0<br>(25.4) |
| 3-in.<br>(76 mm)   | 5.375<br>(136.53)        | 5.875<br>(149.23)   | 5.875<br>(149.23)   | 6.625<br>(168.275)  | 6.875<br>(174.625)  | 7.750<br>(196.85)   | 4.0<br>(101.6) | 1.0<br>(25.4) |
| 4-in.<br>(100 mm)  | 6.875<br>(174.63)        | 7.125<br>(180.98)   | 7.625<br>(193.68)   | 8.125<br>(206.35)   | 8.250<br>(209.550)  | 9.250<br>(234.95)   | 4.0<br>(101.6) | 1.0<br>(25.4) |
| 6-in.<br>(150 mm)  | 8.750<br>(222.25)        | 9.875<br>(250.83)   | 10.500<br>(266.7)   | 11.375<br>(288.925) | 11.125<br>(282.575) | 12.500<br>(317.50)  | 4.0<br>(101.6) | 1.0<br>(25.4) |
| 8-in.<br>(200 mm)  | 11.000<br>(279.4)        | 12.125<br>(307.98)  | 12.625<br>(320.675) | 14.125<br>(358.775) | 13.875<br>(352.425) | 15.250<br>(387.350) | 6.0<br>(152.4) | 1.5<br>(38.1) |
| 10-in.<br>(250 mm) | 13.375<br>(339.73)       | 14.250<br>(361.95)  | 15.750<br>(400.05)  | 17.125<br>(434.975) | 17.125<br>(434.975) | 18.750<br>(476.25)  | 6.0<br>(152.4) | 1.5<br>(38.1) |
| 12-in.<br>(300 mm) | 16.125<br>(409.58)       | 16.625<br>(422.26)  | 18.000<br>(457.2)   | 19.625<br>(498.475) | 20.500<br>(520.7)   | 21.625<br>(549.275) | 6.0<br>(152.4) | 1.5<br>(38.1) |
| 14-in.<br>(350 mm) | 17.750<br>(450.85)       | 19.125<br>(485.78)  | 19.375<br>(492.125) |                     |                     |                     | 6.0<br>(152.4) | 1.5<br>(38.1) |
| 16-in.<br>(400 mm) | 20.250<br>(514.35)       | 21.250<br>(539.75)  | 22.250<br>(565.15)  |                     |                     |                     | 6.0<br>(152.4) | 1.5<br>(38.1) |
| 18-in.<br>(450 mm) | 21.500<br>(546.1)        | 23.375<br>(593.725) | 24.000<br>(609.6)   |                     |                     |                     | 6.0<br>(152.4) | 1.5<br>(38.1) |
| 20-in.<br>(500 mm) | 23.750<br>(603.25)       | 25.625<br>(650.875) | 26.750<br>(679.45)  |                     |                     |                     | 6.0<br>(152.4) | 1.5<br>(38.1) |
| 24-in.<br>(600 mm) | 28.125<br>(714.375)      | 30.375<br>(771.525) | 31.000<br>(787.4)   |                     |                     |                     | 6.0<br>(152.4) | 1.5<br>(38.1) |

NOTE: Consult factory for availability of line sizes and flange ratings not shown in the above table.

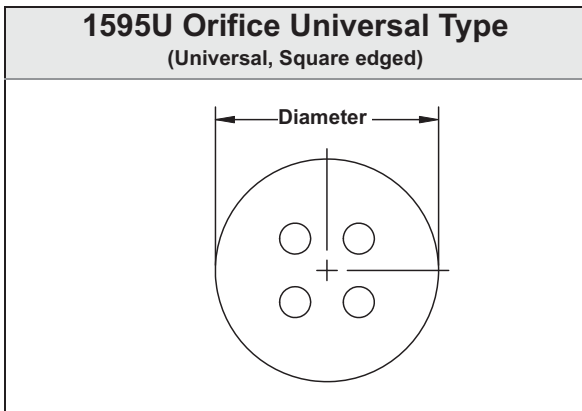

Table 33. A.P.I Ring No.'s and Rating

| Line Size       | Diameter for Universal Type | A.P.I Ring No. | Rating (lbs.) |
|-----------------|-----------------------------|----------------|---------------|
| 2-in. (50 mm)   | 2.437-in. (61.8998 mm)      | R-23           | 300-600       |
|                 |                             | R-24           | 900-1500      |
|                 |                             | R-26           | 2500          |
| 3-in. (76 mm)   | 3.437-in. (87.2998 mm)      | R-31           | 300-600 & 900 |
|                 |                             | R-32           | 2500          |
|                 |                             | R-35           | 1500          |
| 4-in. (100 mm)  | 4.406-in. (111.912 mm)      | R-37           | 300-600 & 900 |
|                 |                             | R-38           | 2500          |
|                 |                             | R-39           | 1500          |
| 6-in. (150 mm)  | 6.437-in. (163.5 mm)        | R-45           | 300-600 & 900 |
|                 |                             | R-46           | 1500          |
|                 |                             | R-47           | 2500          |
| 8-in. (200 mm)  | 8.437-in. (214.3 mm)        | R-49           | 300-600 & 900 |
|                 |                             | R-50           | 1500          |
|                 |                             | R-51           | 2500          |
| 10-in. (250 mm) | 10.687-in. (271.45 mm)      | R-53           | 300-600 & 900 |
|                 |                             | R-54           | 1500          |
|                 |                             | R-55           | 2500          |
| 12-in. (300 mm) | 12.593-in. (319.862 mm)     | R-57           | 300-600 & 900 |
|                 |                             | R-58           | 1500          |
|                 |                             | R-59           | 2500          |

**NOTE**

Refer to Table 32 for line size and pressure rating availability.

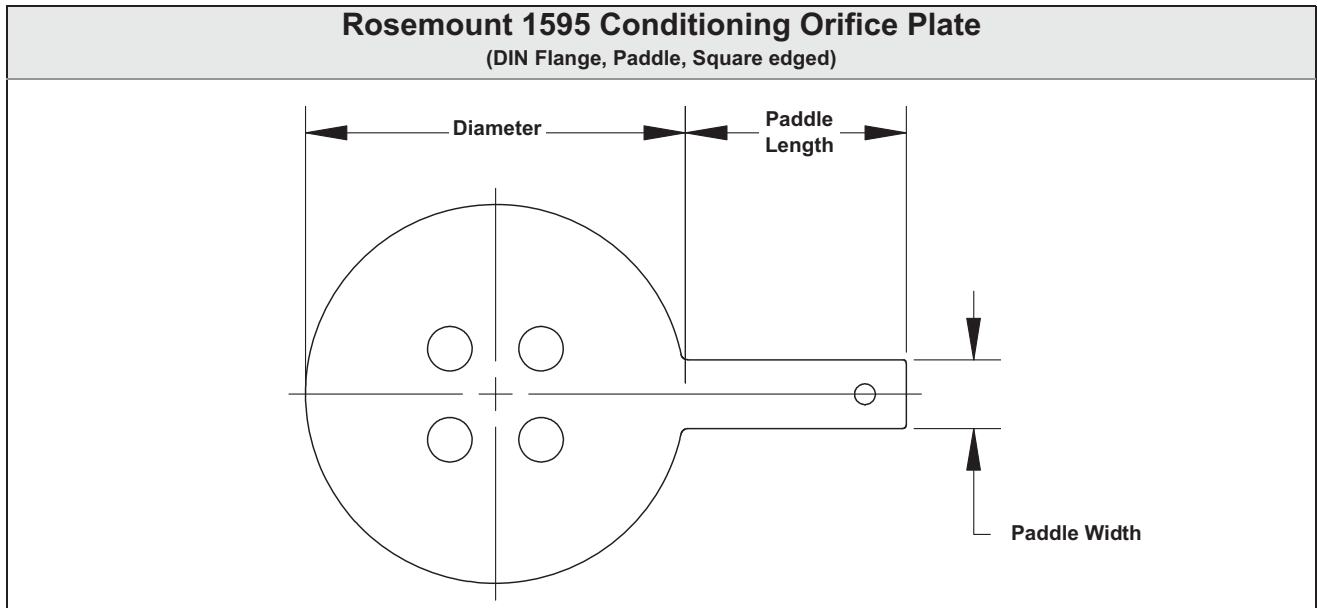

Table 34. 1595 Conditioning Orifice Plate Dimensions in millimeters (inches)

| Line Size       | Diameter (max) – by flange rating |             |             |             |             |             | Paddle Length | Paddle Width |
|-----------------|-----------------------------------|-------------|-------------|-------------|-------------|-------------|---------------|--------------|
|                 | PN 10                             | PN 16       | PN 25       | PN 40       | PN 63/64    | PN 100      |               |              |
| DN 50 (2-in.)   | 107 (4.21)                        | 107 (4.21)  | 107 (4.21)  | 107 (4.21)  | 113 (4.45)  | 119 (4.69)  | 101.6 (4.0)   | 25.4 (1.0)   |
| DN 80 (3-in.)   | 142 (5.60)                        | 142 (5.60)  | 142 (5.60)  | 142 (5.60)  | 148 (5.82)  | 154 (6.06)  | 101.6 (4.0)   | 25.4 (1.0)   |
| DN 100 (4-in.)  | 162 (6.38)                        | 162 (6.38)  | 168 (6.61)  | 168 (6.61)  | 174 (6.85)  | 180 (7.09)  | 101.6 (4.0)   | 25.4 (1.0)   |
| DN 150 (6-in.)  | 218 (8.58)                        | 218 (8.58)  | 224 (8.82)  | 224 (8.82)  | 247 (9.72)  | 257 (10.12) | 101.6 (4.0)   | 25.4 (1.0)   |
| DN 200 (8-in.)  | 273 (10.74)                       | 273 (10.74) | 284 (11.18) | 290 (11.42) | 309 (12.17) | 324 (12.76) | 152.4 (6.0)   | 38.1 (1.5)   |
| DN 250 (10-in.) | 328 (12.91)                       | 329 (12.95) | 340 (13.39) | 352 (13.86) | 364 (14.33) | 391 (15.39) | 152.4 (6.0)   | 38.1 (1.5)   |
| DN 300 (12-in.) | 378 (14.88)                       | 384 (15.12) | 400 (15.75) | 417 (16.42) | 424 (16.69) | 458 (18.03) | 152.4 (6.0)   | 38.1 (1.5)   |

NOTE: Consult factory for availability of line sizes and flange ratings not shown in the above table.

**Product Data Sheet**

00813-1000-4485, Rev CA

November 2011

**Rosemount DP Flow**

Table 35. Conditioning Orifice Plate Available Beta Ratio ( $\beta$ )

The table below shows the available Beta Ratio ( $\beta$ ) for line size vs. pipe schedule

| Line Size | Pipe Schedule | Beta ( $\beta$ ) Available | Line Size | Pipe Schedule | Beta ( $\beta$ ) Available |
|-----------|---------------|----------------------------|-----------|---------------|----------------------------|
| 2         | ≤ 80          | 0.20, 0.40, 0.60           | 14        | ≤ 80          | 0.20, 0.40, 0.65           |
| 2         | 160           | 0.20                       | 14        | 100           | 0.20, 0.40                 |
| 3         | ≤ 80          | 0.20, 0.40, 0.65           | 14        | 120           | 0.20, 0.40                 |
| 3         | 160           | 0.20, 0.40                 | 14        | 140           | 0.20, 0.40                 |
| 3         | XXS           | 0.20                       | 14        | 160           | 0.20, 0.40                 |
| 4         | ≤ 80          | 0.20, 0.40, 0.65           | 14        | XXS           | 0.20, 0.40                 |
| 4         | 120           | 0.20, 0.40                 | 16        | ≤ 80          | 0.20, 0.40, 0.65           |
| 4         | 160           | 0.20, 0.40                 | 16        | 100           | 0.20, 0.40                 |
| 4         | XXS           | 0.20                       | 16        | 120           | 0.20, 0.40                 |
| 6         | ≤ 80          | 0.20, 0.40, 0.65           | 16        | 140           | 0.20, 0.40                 |
| 6         | 120           | 0.20, 0.40                 | 16        | 160           | 0.20, 0.40                 |
| 6         | 160           | 0.20, 0.40                 | 16        | XXS           | 0.20, 0.40                 |
| 6         | XXS           | 0.20                       | 18        | ≤ 80          | 0.20, 0.40, 0.65           |
| 8         | ≤ 80          | 0.20, 0.40, 0.65           | 18        | 100           | 0.20, 0.40, 0.65           |
| 8         | 100           | 0.20, 0.40, 0.65           | 18        | 120           | 0.20, 0.40                 |
| 8         | 120           | 0.20, 0.40                 | 18        | 140           | 0.20, 0.40                 |
| 8         | 140           | 0.20, 0.40                 | 18        | 160           | 0.20, 0.40                 |
| 8         | 160           | 0.20, 0.40                 | 18        | XXS           | 0.20, 0.40                 |
| 8         | XXS           | 0.20, 0.40                 | 20        | ≤ 80          | 0.20, 0.40, 0.65           |
| 10        | ≤ 80          | 0.20, 0.40, 0.65           | 20        | 100           | 0.20, 0.40, 0.65           |
| 10        | 100           | 0.20, 0.40, 0.65           | 20        | 120           | 0.20, 0.40                 |
| 10        | 120           | 0.20, 0.40                 | 20        | 140           | 0.20, 0.40                 |
| 10        | 140           | 0.20, 0.40                 | 20        | 160           | 0.20, 0.40                 |
| 10        | 160           | 0.20, 0.40                 | 20        | XXS           | 0.20, 0.40                 |
| 10        | XXS           | 0.20, 0.40                 | 24        | ≤ 80          | 0.20, 0.40, 0.65           |
| 12        | ≤ 80          | 0.20, 0.40, 0.65           | 24        | 100           | 0.20, 0.40                 |
| 12        | 100           | 0.20, 0.40                 | 24        | 120           | 0.20, 0.40                 |
| 12        | 120           | 0.20, 0.40                 | 24        | 140           | 0.20, 0.40                 |
| 12        | 140           | 0.20, 0.40                 | 24        | 160           | 0.20, 0.40                 |
| 12        | 160           | 0.20, 0.40                 | 24        | XXS           | 0.20, 0.40                 |
| 12        | XXS           | 0.20, 0.40                 |           |               |                            |

# Rosemount DP Flow

**Product Data Sheet**  
00813-1000-4485, Rev CA  
November 2011

## 1195 DIMENSIONAL DRAWINGS

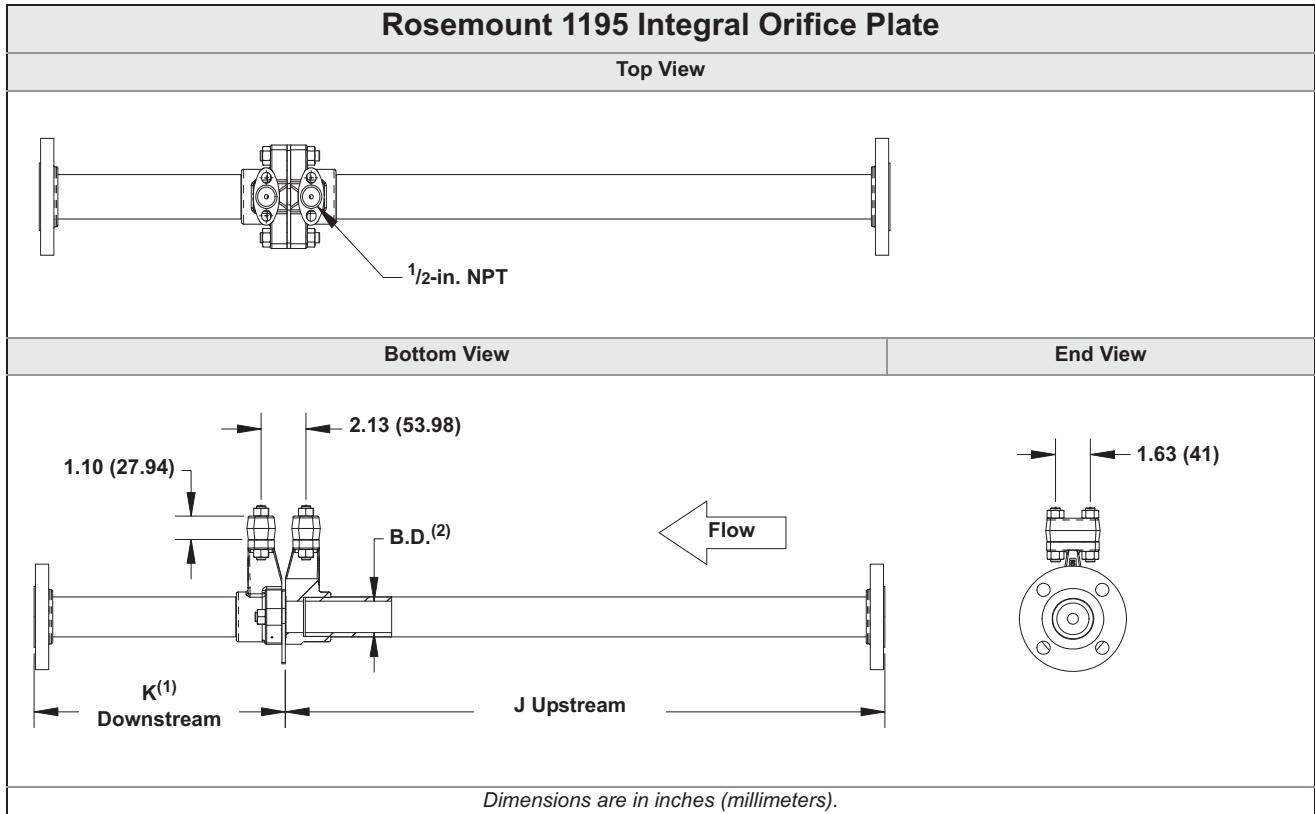

Table 36. 1195 Integral Orifice Plate Dimensional Data

| Dimension   | Line Size       |               |                   |
|---|-----------------|---------------|-------------------|
|   | 1/2-in. (15 mm) | 1-in. (25 mm) | 1 1/2-in. (40 mm) |
| J (Beveled/Threaded pipe ends)                                | 12.54 (318.4)   | 20.24 (514.0) | 28.44 (722.4)     |
| J (RF slip-on, RTJ slip-on, RF-DIN slip-on)                   | 12.62 (320.4)   | 20.32 (516.0) | 28.52 (724.4)     |
| J (RF 150#, weld-neck)  | 14.37 (364.9)   | 22.37 (568.1) | 30.82 (782.9)     |
| J (RF 300#, weld-neck)  | 14.56 (369.8)   | 22.63 (574.7) | 31.06 (789.0)     |
| J (RF 600#, weld-neck)  | 14.81 (376.0)   | 22.88 (581.0) | 31.38 (797.1)     |
| K ((RF slip-on, RTJ slip-on, RF-DIN slip-on) <sup>(1)</sup> ) | 5.82 (147.8)    | 8.83 (224.2)  | 11.99 (304.6)     |
| K (RF 150#, weld-neck)  | 7.57 (192.3)    | 10.88 (276.3) | 14.29 (363.1)     |
| K (RF 300#, weld-neck)  | 7.76 (197.1)    | 11.14 (282.9) | 14.53 (369.2)     |
| K (RF 600#, weld-neck)  | 8.01 (203.4)    | 11.39 (289.2) | 14.85 (377.2)     |
| B.D.(Bore Diameter) <sup>(2)</sup>                            | 0.664 (16.86)   | 1.097 (27.86) | 1.567 (39.80)     |

*Dimensions are in inches (millimeters).*

(1) Downstream length shown here includes plate thickness of 0.162-in. (4.11 mm).

(2) B.D is diameter of the precision bored portion of the upstream and downstream piping.

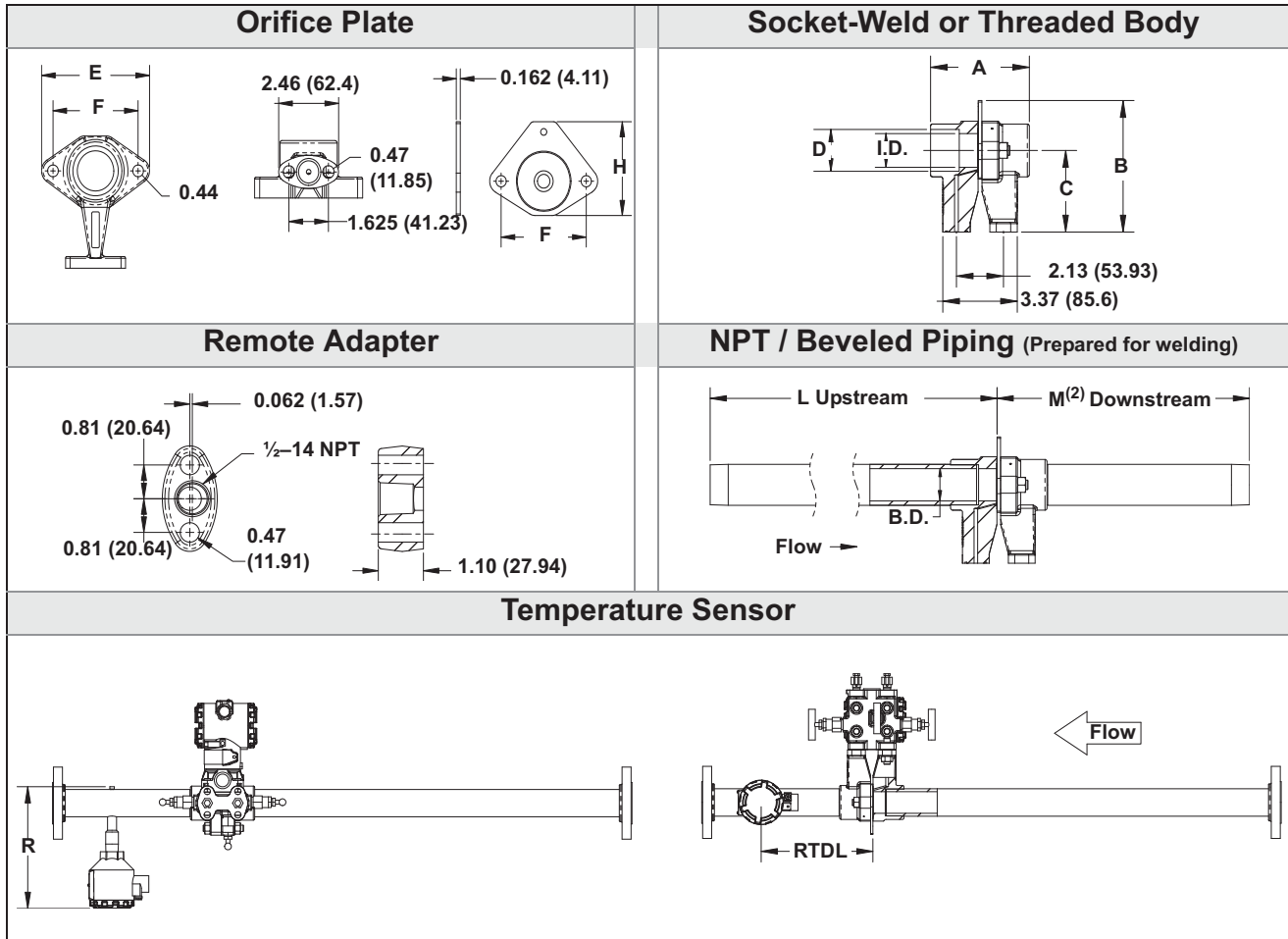

Table 37. 1195 Integral Orifice Dimensional Data

| Dimension                           | Line Size         |           |                 |           |                     |           |
|-------------------------------------|-------------------|-----------|-----------------|-----------|---------------------|-----------|
|                                     | 1/2-in. (12.7 mm) |           | 1-in. (25.4 mm) |           | 1 1/2-in. (38.1 mm) |           |
| A                                   | 3.4-in.           | 86 mm     | 3.8-in.         | 97 mm     | 4.5-in.             | 114 mm    |
| B                                   | 4.7-in.           | 119.4 mm  | 5.2-in.         | 132 mm    | 5.9-in.             | 149.9 mm  |
| C                                   | 3.0-in.           | 76 mm     | 3.3-in.         | 84 mm     | 3.7-in.             | 94 mm     |
| D <sup>(1)</sup>                    | 0.805-in.         | 20.45 mm  | 1.280-in.       | 32.51 mm  | 1.865-in.           | 47.37 mm  |
| E                                   | 3.6-in.           | 91 mm     | 3.9-in.         | 99 mm     | 4.4-in.             | 112 mm    |
| F                                   | 2.6-in.           | 66 mm     | 3.0-in.         | 76 mm     | 3.5-in.             | 89 mm     |
| H                                   | 2.5-in.           | 64 mm     | 3.0-in.         | 76 mm     | 3.5-in.             | 89 mm     |
| L                                   | 12.54-in.         | 318.4 mm  | 20.24-in.       | 514 mm    | 28.44-in.           | 722.4 mm  |
| M                                   | 5.74-in.          | 145.7 mm  | 8.75-in.        | 222.2mm   | 11.91-in.           | 302.6 mm  |
| R                                   | 7.4-in.           | 187.96 mm | 7.8-in.         | 198.12 mm | 8.4-in.             | 213.36 mm |
| RTDL                                | 3.11-in.          | 78.9 mm   | 5.25-in.        | 133.4 mm  | 7.50-in.            | 190.5 mm  |
| B.D. (Bore Diameter) <sup>(2)</sup> | 0.664-in.         | 16.87 mm  | 1.097-in.       | 27.86 mm  | 1.567-in.           | 39.80 mm  |
| I.D. (Inside Diameter)              | 0.622-in.         | 15.80 mm  | 1.049-in.       | 26.64 mm  | 1.500-in.           | 38.10 mm  |

(1) To improve pipe perpendicularity for gasket sealing, socket diameter "D" is smaller than standard pipe O.D. Pipe O.D. must be machined smaller than socket diameter "D" to ensure proper fit.

(2) B.D. is diameter of the precision bored portion of the upstream and downstream piping.

## 1495 DIMENSIONAL DRAWINGS

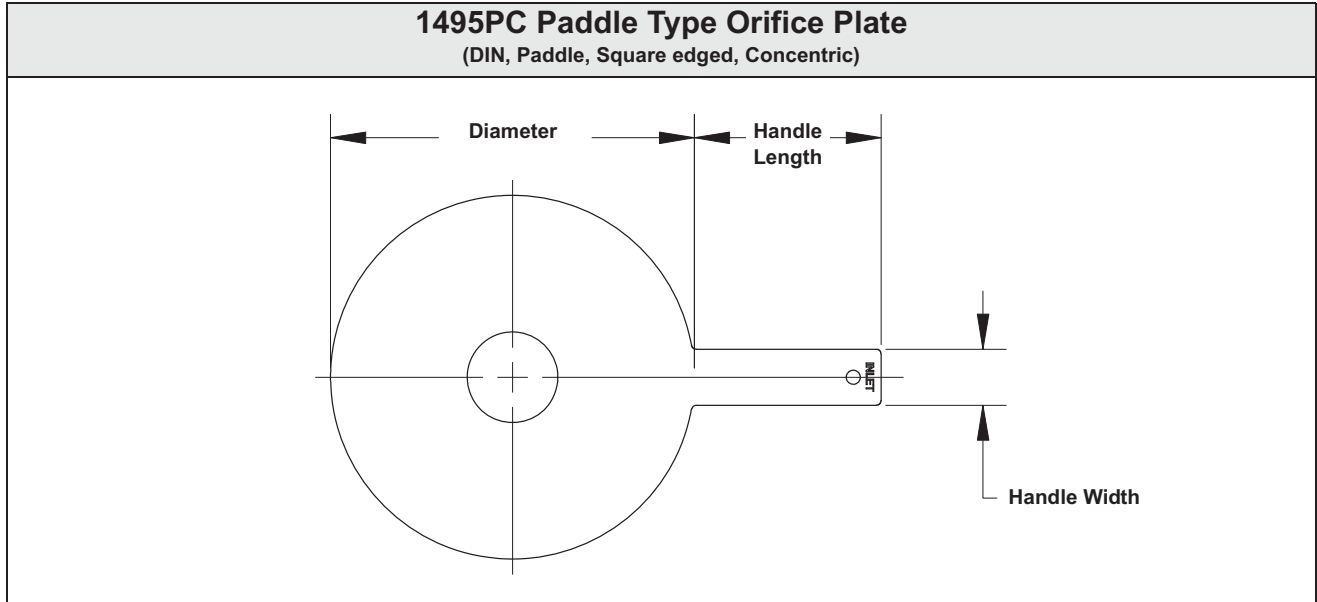
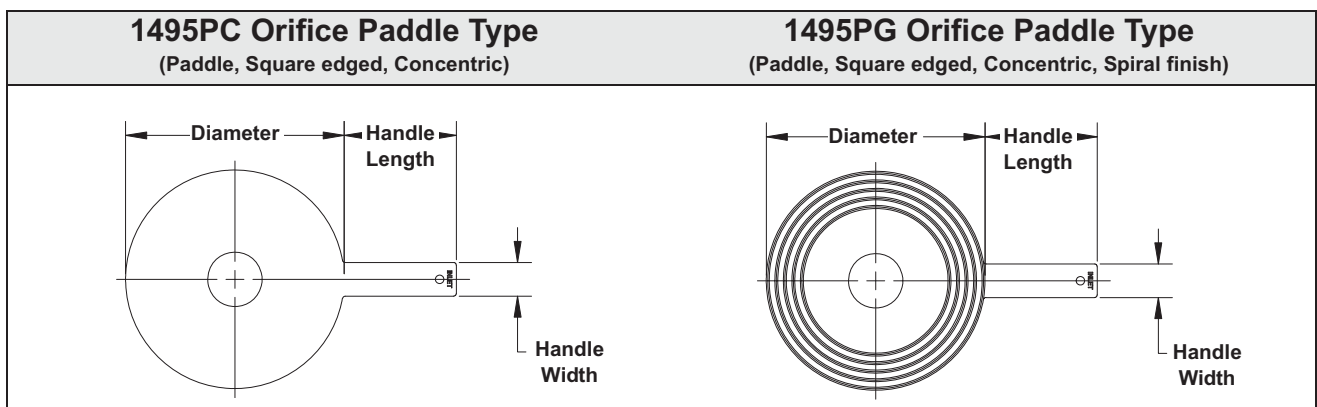

Table 38. 1495 Orifice Plate Dimensions<sup>(1)</sup>

| DN     | Diameter (max) – by flange rating |             |             |             |                |                | Handle Width | Handle Length |
|--------|-----------------------------------|-------------|-------------|-------------|----------------|----------------|--------------|---------------|
|        | PN 10                             | PN 16       | PN 25       | PN 40       | PN 63/64       | PN 100         |              |               |
| DN 50  | 4.21 (107)                        | 4.21 (107)  | 4.21 (107)  | 4.21 (107)  | 4.45 (113)     | 4.69 (119)     | 1.5 (40)     | 6.3 (160)     |
| DN 65  | 5 (127)                           | 5 (127)     | 5 (127)     | 5 (127)     | 5.43 (138)     | 5.67 (144)     | 1.5 (40)     | 6.3 (160)     |
| DN 80  | 5.6 (142)                         | 5.6 (142)   | 5.6 (142)   | 5.6 (142)   | 5.82 (148)     | 6.06 (154)     | 1.5 (40)     | 6.3 (160)     |
| DN 100 | 6.38 (162)                        | 6.38 (162)  | 6.61 (168)  | 6.61 (168)  | 6.85 (174)     | 7.09 (180)     | 1.5 (40)     | 6.3 (160)     |
| DN 125 | 7.56 (192)                        | 7.56 (192)  | 7.64 (194)  | 7.63 (194)  | 8.27 (210)     | 8.54 (217)     | 1.5 (40)     | 6.3 (160)     |
| DN 150 | 8.58 (218)                        | 8.58 (218)  | 8.82 (224)  | 8.82 (224)  | 9.72 (247)     | 10.12 (257)    | 1.5 (40)     | 6.3 (160)     |
| DN 200 | 10.74 (273)                       | 10.74 (273) | 11.18 (284) | 11.42 (290) | 12.17 (309)    | 12.76 (324)    | 1.5 (40)     | 6.3 (160)     |
| DN 250 | 12.91 (328)                       | 12.95 (329) | 13.39 (340) | 13.86 (352) | 14.33 (364)    | 15.39 (391)    | 1.5 (40)     | 6.3 (160)     |
| DN 300 | 14.88 (378)                       | 15.11 (384) | 15.75 (400) | 16.42 (417) | 16.69 (424)    | 18.03 (458)    | 1.5 (40)     | 6.3 (160)     |
| DN 350 | 17.24 (438)                       | 17.48 (444) | 17.99 (457) | 18.66 (474) | 19.13 (486)    | 20.16 (512)    | 1.5 (40)     | 6.3 (160)     |
| DN 400 | 19.25 (489)                       | 19.49 (495) | 20.24 (514) | 21.49 (546) | 21.38 (543)    | 22.52 (572)    | 1.5 (40)     | 6.3 (160)     |
| DN 450 | 21.22 (539)                       | 21.85 (555) | 22.24 (565) | 22.48 (571) | Not Applicable | Not Applicable | 1.5 (40)     | 6.3 (160)     |
| DN 500 | 23.39 (594)                       | 24.29 (617) | 24.57 (624) | 24.72 (628) | 25.87 (657)    | 27.72 (704)    | 1.5 (40)     | 8.0 (200)     |
| DN 600 | 27.36 (695)                       | 28.9 (734)  | 28.78 (731) | 29.41 (747) | 30.08 (764)    | 32.01 (813)    | 1.5 (40)     | 8.0 (200)     |

(1) Measurement is in inches (millimeters)



# Product Data Sheet

00813-1000-4485, Rev CA  
November 2011

# Rosemount DP Flow

| Line Size | Diameter for Paddle Type <sup>(1)</sup> |                     |                     |                     |                     |                     | Handle Length  | Handle Width   |
|-----------|---|---------------------|---------------------|---------------------|---------------------|---------------------|----------------|----------------|
|           | 150#                                    | 300#                | 600#                | 900#                | 1500#               | 2500#               |                |                |
| 2-in.     | 4.125<br>(104.78)                       | 4.375<br>(111.13)   | 4.375<br>(111.13)   | 5.625<br>(142.875)  | 5.625<br>(142.875)  | 5.750<br>(146.05)   | 4.0<br>(101.6) | 1.00<br>(25.4) |
| 2 1/2-in. | 4.875<br>(123.82)                       | 5.125<br>(130.18)   | 5.125<br>(130.18)   | 6.500<br>(165.1)    | 6.500<br>(165.1)    | 6.625<br>(168.275)  | 4.0<br>(101.6) | 1.00<br>(25.4) |
| 3-in.     | 5.375<br>(136.53)                       | 5.875<br>(149.23)   | 5.875<br>(149.23)   | 6.625<br>(168.275)  | 6.875<br>(174.625)  | 7.750<br>(196.85)   | 4.0<br>(101.6) | 1.00<br>(25.4) |
| 4-in.     | 6.875<br>(174.63)                       | 7.125<br>(180.98)   | 7.625<br>(193.675)  | 8.125<br>(206.375)  | 8.250<br>(209.55)   | 9.250<br>(234.95)   | 4.0<br>(101.6) | 1.00<br>(25.4) |
| 6-in.     | 8.750<br>(222.25)                       | 9.875<br>(250.83)   | 10.500<br>(266.7)   | 11.375<br>(288.925) | 11.125<br>(282.575) | 12.500<br>(317.5)   | 4.0<br>(101.6) | 1.00<br>(25.4) |
| 8-in.     | 11.000<br>(279.4)                       | 12.125<br>(307.98)  | 12.625<br>(320.675) | 14.125<br>(358.775) | 13.875<br>(352.425) | 15.250<br>(387.35)  | 6.0<br>(127)   | 1.5<br>(38.1)  |
| 10-in.    | 13.375<br>(339.73)                      | 14.250<br>(361.95)  | 15.750<br>(400.05)  | 17.125<br>(434.975) | 17.125<br>(434.975) | 18.750<br>(476.25)  | 6.0<br>(152.4) | 1.5<br>(38.1)  |
| 12-in.    | 16.125<br>(409.58)                      | 16.625<br>(422.26)  | 18.000<br>(457.2)   | 19.625<br>(498.475) | 20.500<br>(520.7)   | 21.625<br>(549.275) | 6.0<br>(152.4) | 1.5<br>(38.1)  |
| 14-in.    | 17.750<br>(450.85)                      | 19.125<br>(485.78)  | 19.375<br>(339.725) | 20.500<br>(520.7)   | 22.750<br>(577.85)  | —                   | 6.0<br>(152.4) | 1.5<br>(38.1)  |
| 16-in.    | 20.250<br>(514.35)                      | 21.250<br>(539.75)  | 22.250<br>(565.15)  | 22.625<br>(574.675) | 25.250<br>(641.35)  | —                   | 6.0<br>(152.4) | 1.5<br>(38.1)  |
| 18-in.    | 21.500<br>(546.1)                       | 23.375<br>(593.725) | 24.000<br>(609.6)   | 25.000<br>(635.00)  | 27.625<br>(701.675) | —                   | 6.0<br>(152.4) | 1.5<br>(38.1)  |
| 20-in.    | 23.750<br>(603.25)                      | 25.625<br>(650.875) | 26.750<br>(679.45)  | 27.375<br>(695.325) | 29.625<br>(752.475) | —                   | 6.0<br>(152.4) | 1.5<br>(38.1)  |
| 24-in.    | 28.125<br>(714.375)                     | 30.375<br>(771.525) | 31.000<br>(787.4)   | 32.875<br>(835.025) | 35.500<br>(901.7)   | —                   | 6.0<br>(152.4) | 1.5<br>(38.1)  |

(1) Measurement is in inches (millimeters)

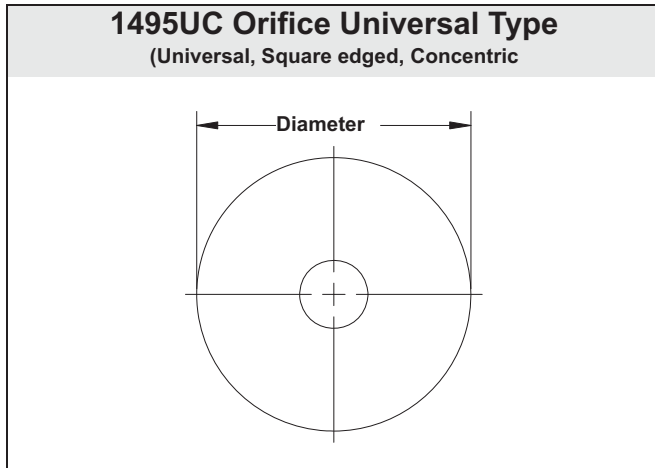

(1) Measurement is in inches (millimeters)

| Line Size | Diameter for Universal Type <sup>(1)</sup> |
|-----------|--|
| 2-in.     | 2.437 (61.8998)                            |
| 2 1/2-in. | 2.812 (71.4248)                            |
| 3-in.     | 3.437 (87.2998)                            |
| 4-in.     | 4.406 (111.912)                            |
| 6-in.     | 6.437 (163.5)                              |
| 8-in.     | 8.437 (214.3)                              |
| 10-in.    | 10.687 (271.45)                            |
| 12-in.    | 12.593 (319.862)                           |
| 14-in.    | 14.000 (355.6)                             |
| 16-in.    | 16.000 (406.4)                             |
| 18-in.    | 18.000 (457.2)                             |
| 20-in.    | 20.000 (508)                               |
| 24-in.    | 24.000 (609.6)                             |

## 1496 DIMENSIONAL DRAWINGS

Figure 5. Class 300

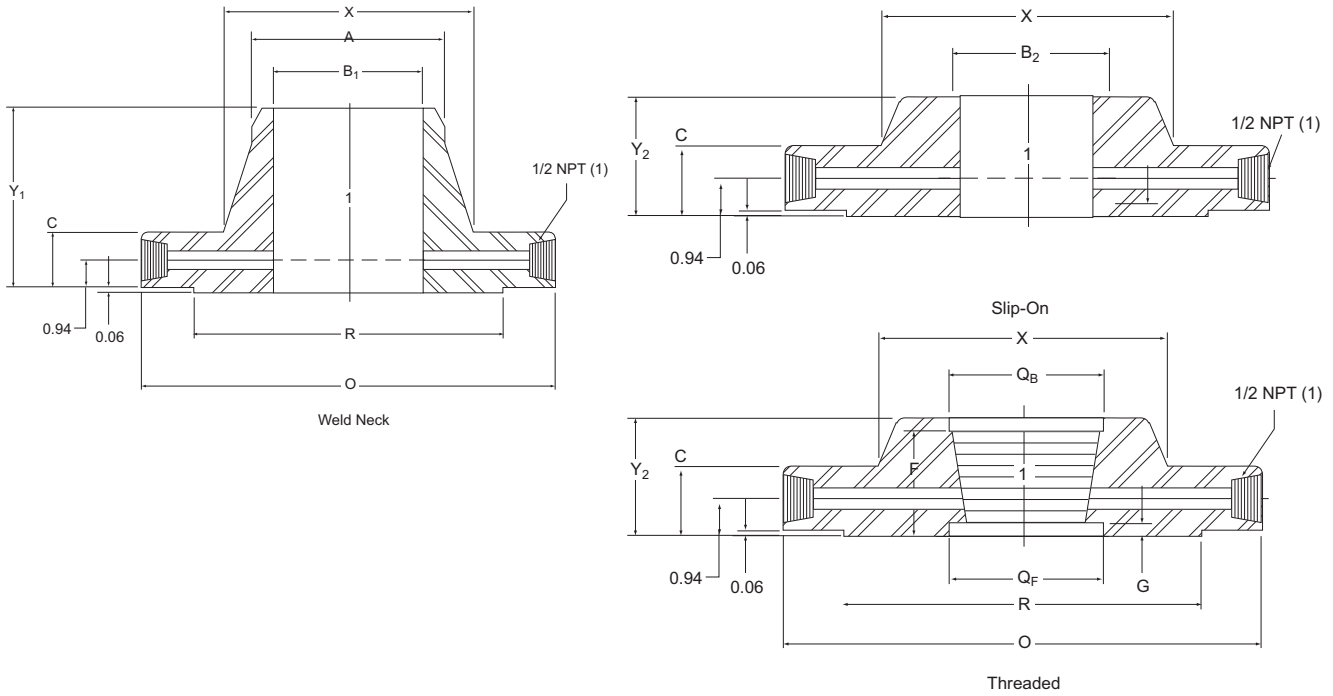

## ASME B16.36-1996

Table 39. Class 300 Orifice Flanges, Welding Neck, Slip-On, and Threaded<sup>(1)(2)</sup>

| Nominal Pipe Size | Outside Diameter of Raised Face R | Outside Diameter of Flange O | Thickness of Flange, Min. C | Length Through Hub                  |                          | Diameter of Hub X | Hub Diameter Beginning of Chamfer (W.N.) A | Diameter of Counter-bore |                     | Counter-bore Depth (From Face) |      | Bore                   |                          |
|-------------------|-----------------------------------|------------------------------|-----------------------------|-------------------------------------|--------------------------|-------------------|--|--------------------------|---------------------|--------------------------------|------|------------------------|--------------------------|
|                   |                                   |                              |                             | Slip-On and Threaded Y <sub>2</sub> | Weld Neck Y <sub>1</sub> |                   |  | Back Q <sub>B</sub>      | Face Q <sub>F</sub> | F                              | G    | Slip-On B <sub>2</sub> | Weld Neck B <sub>1</sub> |
| 1                 | 2.00                              | 4.88                         | 1.50                        | 1.88                                | 3.25                     | 2.12              | 1.32                                       | 1.41                     | 1.30                | 1.44                           | 0.75 | 1.36                   | See Note (5)             |
| 1½                | 2.88                              | 6.12                         | 1.50                        | 1.88                                | 3.38                     | 2.75              | 1.90                                       | 1.99                     | 1.89                | 1.47                           | 0.72 | 1.95                   |                          |
| 2                 | 3.62                              | 6.50                         | 1.50                        | 1.94                                | 3.38                     | 3.31              | 2.38                                       | 2.50                     | 2.36                | 1.50                           | 0.69 | 2.44                   |                          |
| 2½                | 4.12                              | 7.50                         | 1.50                        | 2.00                                | 3.50                     | 3.94              | 2.88                                       | 3.00                     | 2.84                | 1.75                           | 0.56 | 2.94                   |                          |
| 3                 | 5.00                              | 8.25                         | 1.50                        | 2.06                                | 3.50                     | 4.62              | 3.50                                       | 3.63                     | 3.46                | 1.81                           | 0.56 | 3.57                   |                          |
| 4                 | 6.19                              | 10.00                        | 1.50                        | 2.12                                | 3.62                     | 5.75              | 4.50                                       | 4.63                     | 4.45                | 1.88                           | 0.56 | 4.57                   |                          |
| 6                 | 8.50                              | 12.50                        | 1.50                        | 2.12                                | 3.94                     | 8.12              | 6.63                                       | 6.75                     | 6.57                | 1.88                           | 0.31 | 6.72                   |                          |
| 8                 | 10.62                             | 15.00                        | 1.62                        | 2.44                                | 4.38                     | 10.25             | 8.63                                       | 8.75                     | 8.55                | 2.19                           | 0.44 | 8.72                   |                          |
| 10                | 12.75                             | 17.50                        | 1.88                        | 2.62                                | 4.62                     | 12.62             | 10.75                                      | See Note (6).            |                     |                                |      | 10.88                  |                          |
| 12                | 15.00                             | 20.50                        | 2.00                        | 2.88                                | 5.12                     | 14.75             | 12.75                                      |                          |                     |                                |      | 12.88                  |                          |
| 14                | 16.25                             | 23.00                        | 2.12                        | 3.00                                | 5.62                     | 16.75             | 14.00                                      |                          |                     |                                |      | 14.14                  |                          |
| 16                | 18.50                             | 25.50                        | 2.25                        | 3.25                                | 5.75                     | 19.00             | 16.00                                      |                          |                     |                                |      | 16.16                  |                          |
| 18                | 21.00                             | 28.00                        | 2.38                        | 3.50                                | 6.25                     | 21.00             | 18.00                                      |                          |                     |                                |      | 18.18                  |                          |
| 20                | 23.00                             | 30.50                        | 2.50                        | 3.75                                | 6.38                     | 23.12             | 20.00                                      |                          |                     |                                |      | 20.20                  |                          |
| 24                | 27.25                             | 36.00                        | 2.75                        | 4.19                                | 6.62                     | 27.62             | 24.00                                      | 24.25                    |                     |                                |      |                        |                          |

# Product Data Sheet

00813-1000-4485, Rev CA

November 2011

# Rosemount DP Flow

| Nominal Pipe Size (1)(2) | Diameter of Pressure Connection TT | Drilling Template |                 |                   |                   | Bolt Length (3)(4) |            |
|--------------------------|------------------------------------|-------------------|-----------------|-------------------|-------------------|--------------------|------------|
|                          |                                    | Bolt Circle       | Number of Holes | Diameter of Holes | Diameter of Bolts | Machine Bolts      | Stud Bolts |
| 1                        | 1/4                                | 3.50              | 4               | 0.69              | 5/8               | 4.50               | 5.00       |
| 1 1/2                    | 1/4                                | 4.50              | 4               | 0.81              | 3/4               | 4.75               | 5.25       |
| 2                        | 1/4                                | 5.00              | 8               | 0.69              | 5/8               | 4.50               | 5.00       |
| 2 1/2                    | 1/4                                | 5.88              | 8               | 0.81              | 3/4               | 4.75               | 5.25       |
| 3                        | 3/8                                | 6.62              | 8               | 0.81              | 3/4               | 4.75               | 5.25       |
| 4                        | 1/2                                | 7.88              | 8               | 0.81              | 3/4               | 4.75               | 5.25       |
| 6                        | 1/2                                | 10.62             | 12              | 0.88              | 3/4               | 4.75               | 5.25       |
| 8                        | 1/2                                | 13.00             | 12              | 1.00              | 7/8               | 5.00               | 5.75       |
| 10                       | 1/2                                | 15.25             | 16              | 1.12              | 1                 | 5.75               | 6.50       |
| 12                       | 1/2                                | 17.75             | 16              | 1.25              | 1 1/8             | 6.25               | 7.00       |
| 14                       | 1/2                                | 20.25             | 20              | 1.25              | 1 1/8             | 6.50               | 7.25       |
| 16                       | 1/2                                | 22.50             | 20              | 1.38              | 1 1/4             | 7.00               | 7.75       |
| 18                       | 1/2                                | 24.75             | 24              | 1.38              | 1 1/4             | 7.25               | 8.00       |
| 20                       | 1/2                                | 27.00             | 24              | 1.38              | 1 1/4             | 7.50               | 8.50       |
| 24                       | 1/2                                | 32.00             | 24              | 1.62              | 1 1/2             | 8.25               | 9.50       |

- (1) Weld neck flanges NPS 3 and smaller are identical to Class 600 flanges and may be so marked.
- (2) All other dimensions are in accordance with ASME B16.5.
- (3) Bolt lengths include allowance for orifice and gasket thickness of 0.25 in. for NPS 1-12 and 0.38 in. for NPS 14-24.
- (4) In conformance with ASME B16.5, stud bolt lengths do not include point heights.
- (5) Threaded flanges are furnished in NPS 1-8 only.
- (6) Bore diameter of weld neck flanges is to be specified by the purchaser.

Figure 6. Class 600

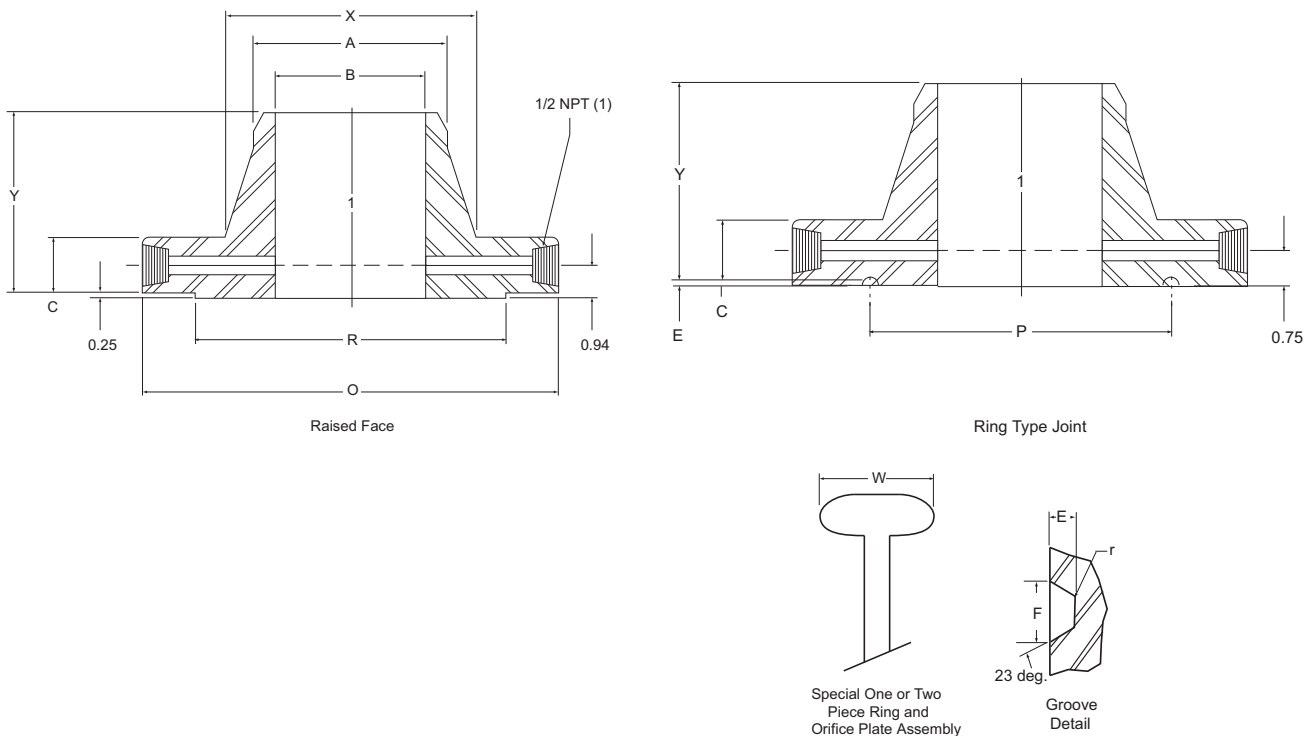

# Rosemount DP Flow

Table 40. Class 600 Orifice Flanges, Welding Neck<sup>(1)(2)</sup>

| Nominal Pipe Size | Outside Diameter of Raised Face R | Outside Diameter of Flange O | Thickness of Flange, Min. C | Length Through Hub Y | Height of Raised Face H | Ring Type Joint |                  |                |                |                            |                            | Hub Diameter Beginning of Chamfer A |                   |
|-------------------|-----------------------------------|------------------------------|-----------------------------|----------------------|-------------------------|-----------------|------------------|----------------|----------------|----------------------------|----------------------------|-------------------------------------|-------------------|
|                   |                                   |                              |                             |                      |                         | Groove Number   | Pitch Diameter P | Groove Depth E | Groove Width F | Radius at Bottom $r_{max}$ | Special Oval Ring Height W |                                     | Diameter of Hub X |
| 1                 | 2.00                              | 4.88                         | 1.44                        | 3.19                 | 0.06                    | R16             | 2.000            | 0.250          | 0.344          | 0.03                       | 1.00                       | 2.12                                | 1.32              |
| 1 1/2             | 2.88                              | 6.12                         | 1.44                        | 3.32                 | 0.06                    | R20             | 2.688            | 0.250          | 0.344          | 0.03                       | 1.00                       | 2.75                                | 1.90              |
| 2                 | 3.62                              | 6.50                         | 1.44                        | 3.32                 | 0.06                    | R23             | 3.250            | 0.312          | 0.469          | 0.03                       | 1.06                       | 3.31                                | 2.38              |
| 2 1/2             | 4.12                              | 7.50                         | 1.44                        | 3.44                 | 0.06                    | R26             | 4.000            | 0.312          | 0.469          | 0.03                       | 1.06                       | 3.94                                | 2.88              |
| 3                 | 5.00                              | 8.25                         | 1.44                        | 3.44                 | 0.06                    | R31             | 4.875            | 0.312          | 0.469          | 0.03                       | 1.06                       | 4.62                                | 3.50              |
| 4                 | 6.19                              | 10.75                        | 1.50                        | 4.00                 | 0.25                    | R37             | 5.875            | 0.312          | 0.469          | 0.03                       | 1.06                       | 6.00                                | 4.50              |
| 6                 | 8.50                              | 14.00                        | 1.88                        | 4.62                 | 0.25                    | R45             | 8.312            | 0.312          | 0.469          | 0.03                       | 1.06                       | 8.75                                | 6.63              |
| 8                 | 10.62                             | 16.50                        | 2.19                        | 5.25                 | 0.25                    | R49             | 10.625           | 0.312          | 0.469          | 0.03                       | 1.06                       | 10.75                               | 8.63              |
| 10                | 12.75                             | 20.00                        | 2.50                        | 6.00                 | 0.25                    | R53             | 12.750           | 0.312          | 0.469          | 0.03                       | 1.06                       | 13.50                               | 10.75             |
| 12                | 15.00                             | 22.00                        | 2.62                        | 6.12                 | 0.25                    | R57             | 15.000           | 0.312          | 0.469          | 0.03                       | 1.06                       | 15.75                               | 12.75             |
| 14                | 16.25                             | 23.75                        | 2.75                        | 6.50                 | 0.25                    | R61             | 16.500           | 0.312          | 0.469          | 0.03                       | 1.06                       | 17.00                               | 14.00             |
| 16                | 18.50                             | 27.00                        | 3.00                        | 7.00                 | 0.25                    | R65             | 18.500           | 0.312          | 0.469          | 0.03                       | 1.19                       | 19.50                               | 16.00             |
| 18                | 21.00                             | 29.25                        | 3.25                        | 7.25                 | 0.25                    | R69             | 21.000           | 0.312          | 0.469          | 0.03                       | 1.19                       | 21.50                               | 18.00             |
| 20                | 23.00                             | 32.00                        | 3.50                        | 7.50                 | 0.25                    | R73             | 23.000           | 0.375          | 0.531          | 0.06                       | 1.25                       | 24.00                               | 20.00             |
| 24                | 27.25                             | 37.00                        | 4.00                        | 8.00                 | 0.25                    | R77             | 27.250           | 0.438          | 0.656          | 0.06                       | 1.44                       | 28.25                               | 24.00             |

| (1)(2) Nominal Pipe Size | Bore B        | Diameter of Pressure Connection TT | Drilling Template |                 |                   |            | Diameter of Bolts | Length of Stud Bolts <sup>(3)(4)</sup> |            |
|--------------------------|---------------|------------------------------------|-------------------|-----------------|-------------------|------------|-------------------|--|------------|
|                          |               |                                    | Bolt Circle       | Number of Holes | Diameter of Holes |            |                   | Raised Face                            | Ring Joint |
|                          |               |                                    |                   |                 | Raised Face       | Ring Joint |                   |  |            |
| 1                        | See Note (4). | 1/4                                | 3.50              | 4               | 0.69              | 0.75       | 5/8               | 5.00                                   | 5.50       |
| 1 1/2                    |               | 1/4                                | 4.50              | 4               | 0.81              | 0.88       | 3/4               | 5.25                                   | 5.50       |
| 2                        |               | 1/4                                | 5.00              | 8               | 0.69              | 0.75       | 5/8               | 5.00                                   | 5.50       |
| 2 1/2                    |               | 1/4                                | 5.88              | 8               | 0.81              | 0.88       | 3/4               | 5.25                                   | 5.75       |
| 3                        |               | 3/8                                | 6.62              | 8               | 0.81              | 0.88       | 3/4               | 5.25                                   | 5.75       |
| 4                        |               | 1/2                                | 8.50              | 8               | 1.00              | 1.00       | 7/8               | 6.00                                   | 6.50       |
| 6                        |               | 1/2                                | 11.50             | 12              | 1.12              | 1.12       | 1                 | 7.00                                   | 7.50       |
| 8                        |               | 1/2                                | 13.75             | 12              | 1.25              | 1.25       | 1 1/8             | 7.75                                   | 8.25       |
| 10                       |               | 1/2                                | 17.00             | 16              | 1.38              | 1.38       | 1 1/4             | 8.75                                   | 9.25       |
| 12                       |               | 1/2                                | 19.25             | 20              | 1.38              | 1.38       | 1 1/4             | 9.00                                   | 9.50       |
| 14                       |               | 1/2                                | 20.75             | 20              | 1.50              | 1.50       | 1 3/8             | 9.50                                   | 10.00      |
| 16                       |               | 1/2                                | 23.75             | 20              | 1.62              | 1.62       | 1 1/2             | 10.25                                  | 10.75      |
| 18                       |               | 1/2                                | 25.75             | 20              | 1.75              | 1.75       | 1 5/8             | 11.00                                  | 11.50      |
| 20                       |               | 1/2                                | 28.50             | 24              | 1.75              | 1.75       | 1 5/8             | 11.75                                  | 12.50      |
| 24                       |               | 1/2                                | 33.00             | 24              | 2.00              | 2.00       | 1 7/8             | 13.25                                  | 13.75      |

- (1) Weld neck flanges NPS 3 and smaller are identical to Class 300 flanges except for bolting and may be used for such service.
- (2) All other dimensions are in accordance with ASME B16.5.
- (3) Bolt lengths for raised face flanges include allowance for orifice and gasket thickness of 0.25 in. for NPS 1-12 and 0.38 in. for NPS 14-24. Bolt lengths for ring type joint flanges include allowance of 0.62 in. for NPS 1-10, 0.75 in. for NPS 12-18, and 0.88 in. for NPS 20.
- (4) In conformance with ASME B16.5, stud bolt lengths do not include point heights.

Figure 7. Class 900

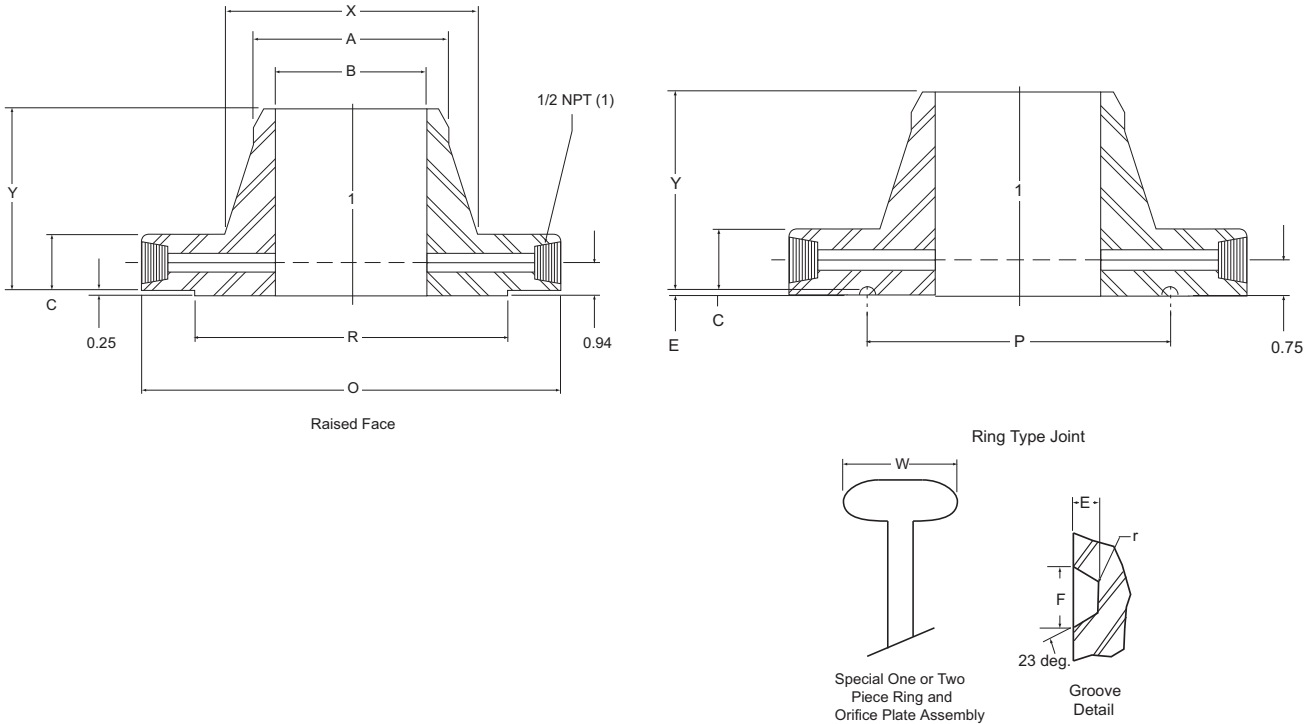

Table 41. Class 900 Orifice Flanges, Welding Neck<sup>(1)</sup>

| Nominal Pipe Size             | Out-side Diameter of Raised Face R   | Out-side Diameter of Flange O | Thickness of Flange, Min. C | Length Through Hub Y | Ring Type Joint |                  |                |                |                            |      | Special Oval Ring Height W | Diameter of Hub X | Hub Diameter Beginning of Chamfer A |
|-------------------------------|--|-------------------------------|-----------------------------|----------------------|-----------------|------------------|----------------|----------------|----------------------------|------|----------------------------|-------------------|-------------------------------------|
|                               |  |                               |                             |                      | Groove Number   | Pitch Diameter P | Groove Depth E | Groove Width F | Radius at Bottom $r_{max}$ |      |                            |                   |                                     |
| 1                             | For Nominal Pipe Size (NPS) 2 <sup>1</sup> / <sub>2</sub> and smaller, use Class 1500. |                               |                             |                      |                 |                  |                |                |                            |      |                            |                   |                                     |
| 1 <sup>1</sup> / <sub>2</sub> |  |                               |                             |                      |                 |                  |                |                |                            |      |                            |                   |                                     |
| 2                             |  |                               |                             |                      |                 |                  |                |                |                            |      |                            |                   |                                     |
| 2 <sup>1</sup> / <sub>2</sub> |  |                               |                             |                      |                 |                  |                |                |                            |      |                            |                   |                                     |
| 3                             | 5.00   | 9.50                          | 1.50                        | 4.00                 | R31             | 4.875            | 0.312          | 0.469          | 0.03                       | 1.06 | 5.00                       | 3.50              |                                     |
| 4                             | 6.19   | 11.50                         | 1.75                        | 4.50                 | R37             | 5.875            | 0.312          | 0.469          | 0.03                       | 1.06 | 6.25                       | 4.50              |                                     |
| 6                             | 8.50   | 15.00                         | 2.19                        | 5.50                 | R45             | 8.312            | 0.312          | 0.469          | 0.03                       | 1.06 | 9.25                       | 6.63              |                                     |
| 8                             | 10.62  | 18.50                         | 2.50                        | 6.38                 | R49             | 10.625           | 0.312          | 0.469          | 0.03                       | 1.06 | 11.75                      | 8.63              |                                     |
| 10                            | 12.75  | 21.50                         | 2.75                        | 7.25                 | R53             | 12.750           | 0.312          | 0.469          | 0.03                       | 1.06 | 14.50                      | 10.75             |                                     |
| 12                            | 15.00  | 24.00                         | 3.12                        | 7.88                 | R57             | 15.000           | 0.312          | 0.469          | 0.03                       | 1.06 | 16.50                      | 12.75             |                                     |
| 14                            | 16.25  | 25.25                         | 3.38                        | 8.38                 | R62             | 16.500           | 0.438          | 0.656          | 0.06                       | 1.31 | 17.75                      | 14.00             |                                     |
| 16                            | 18.50  | 27.75                         | 3.50                        | 8.50                 | R66             | 18.500           | 0.438          | 0.656          | 0.06                       | 1.44 | 20.00                      | 16.00             |                                     |
| 18                            | 21.00  | 31.00                         | 4.00                        | 9.00                 | R70             | 21.000           | 0.500          | 0.781          | 0.06                       | 1.56 | 22.25                      | 18.00             |                                     |
| 20                            | 23.00  | 33.75                         | 4.25                        | 9.75                 | R74             | 23.000           | 0.500          | 0.781          | 0.06                       | 1.56 | 24.50                      | 20.00             |                                     |
| 24                            | 27.25  | 41.00                         | 5.50                        | 11.50                | R78             | 27.250           | 0.625          | 1.062          | 0.09                       | 1.88 | 29.50                      | 24.00             |                                     |

# Rosemount DP Flow

| (1)<br>Nominal<br>Pipe<br>Size | Bore B   | Diameter<br>of<br>Pressure<br>Connection<br>TT | Drilling Template             |                    |                      |                      | Length of Stud Bolts <sup>(2)(3)</sup> |            |
|--------------------------------|--|--|-------------------------------|--------------------|----------------------|----------------------|--|------------|
|                                |  |  | Diameter<br>of Bolt<br>Circle | Number of<br>Holes | Diameter<br>of Holes | Diameter of<br>Bolts | Raised Face                            | Ring Joint |
| 1                              | For Nominal Pipe Size (NPS) 2 1/2 and smaller, use Class 1500. |  |                               |                    |                      |                      |  |            |
| 1 1/2                          |  |  |                               |                    |                      |                      |  |            |
| 2                              |  |  |                               |                    |                      |                      |  |            |
| 2 1/2                          |  |  |                               |                    |                      |                      |  |            |
| 3                              | See Note (4).  | 3/8  | 7.50                          | 8                  | 7.50                 | 7/8                  | 6.00                                   | 6.50       |
| 4                              |  | 1/2  | 9.25                          | 8                  | 9.25                 | 1 1/8                | 7.00                                   | 7.50       |
| 6                              |  | 1/2  | 12.50                         | 12                 | 12.50                | 1 1/8                | 7.75                                   | 8.25       |
| 8                              |  | 1/2  | 15.50                         | 12                 | 15.50                | 1 3/8                | 9.00                                   | 9.50       |
| 10                             |  | 1/2  | 18.50                         | 16                 | 18.50                | 1 3/8                | 9.50                                   | 10.00      |
| 12                             |  | 1/2  | 21.00                         | 20                 | 21.00                | 1 3/8                | 10.25                                  | 10.75      |
| 14                             |  | 1/2  | 22.00                         | 20                 | 22.00                | 1 1/2                | 11.00                                  | 11.50      |
| 16                             |  | 1/2  | 24.25                         | 20                 | 24.25                | 1 5/8                | 11.50                                  | 12.00      |
| 18                             |  | 1/2  | 27.00                         | 20                 | 27.00                | 1 7/8                | 13.00                                  | 13.75      |
| 20                             |  | 1/2  | 29.50                         | 20                 | 29.50                | 2                    | 14.00                                  | 14.75      |
| 24                             |  | 1/2  | 35.50                         | 20                 | 35.50                | 2 1/2                | 17.50                                  | 18.50      |

- (1) All other dimensions are in accordance with ASME B16.5.
- (2) In conformance with ASME B16.5, stud bolt lengths do not include point heights.
- (3) Bolt lengths for raised face flanges include allowance for orifice and gasket thickness of 0.25 in. for NPS 3-12 and 0.38 in. for NPS 14-24. Bolt lengths for ring type joint flanges include allowance of 0.62 in. for NPS 3-10 and 0.75 in. for NPS 12.
- (4) Bore is to be specified by the purchaser.

Figure 8. Class 1500

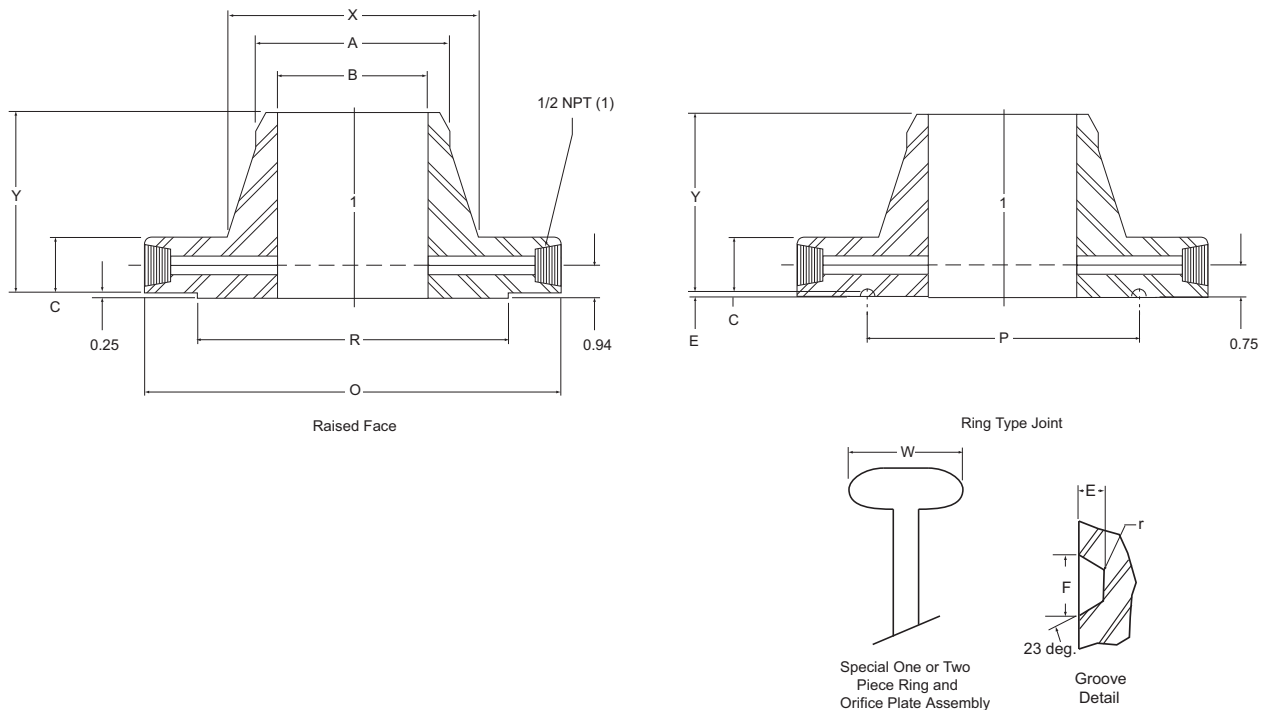

**Product Data Sheet**

00813-1000-4485, Rev CA  
November 2011

**Rosemount DP Flow**

Table 42. Class 1500 Orifice Flanges, Welding Neck<sup>(1)</sup>

| Nominal Pipe Size | Out-side Diameter of Raised Face R | Out-side Diameter of Flange O | Thickness of Flange, Min. C | Length Through Hub Y | Ring Type Joint |                  |                |                |                            |                            | Diameter of Hub X | Hub Diameter Beginning of Chamfer A |
|-------------------|------------------------------------|-------------------------------|-----------------------------|----------------------|-----------------|------------------|----------------|----------------|----------------------------|----------------------------|-------------------|-------------------------------------|
|                   |                                    |                               |                             |                      | Groove Number   | Pitch Diameter P | Groove Depth E | Groove Width F | Radius at Bottom $r_{max}$ | Special Oval Ring Height W |                   |                                     |
| 1                 | 2.00                               | 5.88                          | 1.50                        | 3.25                 | R16             | 2.000            | 0.250          | 0.344          | 0.03                       | 1.00                       | 2.06              | 1.32                                |
| 1 1/2             | 2.88                               | 7.00                          | 1.50                        | 3.50                 | R20             | 2.688            | 0.250          | 0.344          | 0.03                       | 1.00                       | 2.75              | 1.90                                |
| 2                 | 3.62                               | 8.50                          | 1.50                        | 4.00                 | R24             | 3.750            | 0.312          | 0.469          | 0.03                       | 1.06                       | 4.12              | 2.38                                |
| 2 1/2             | 4.12                               | 9.62                          | 1.62                        | 4.12                 | R27             | 4.250            | 0.312          | 0.469          | 0.03                       | 1.06                       | 4.88              | 2.88                                |
| 3                 | 5.00                               | 10.50                         | 1.88                        | 4.62                 | R35             | 5.375            | 0.312          | 0.469          | 0.03                       | 1.06                       | 5.25              | 3.50                                |
| 4                 | 6.19                               | 12.25                         | 2.12                        | 4.88                 | R39             | 6.375            | 0.312          | 0.469          | 0.03                       | 1.06                       | 6.38              | 4.50                                |
| 6                 | 8.50                               | 15.50                         | 3.25                        | 6.75                 | R46             | 8.312            | 0.375          | 0.531          | 0.06                       | 1.12                       | 9.00              | 6.63                                |
| 8                 | 10.62                              | 19.00                         | 3.62                        | 8.38                 | R50             | 10.625           | 0.438          | 0.656          | 0.06                       | 1.31                       | 11.50             | 8.63                                |
| 10                | 12.75                              | 23.00                         | 4.25                        | 10.00                | R54             | 12.750           | 0.438          | 0.656          | 0.06                       | 1.31                       | 14.50             | 10.75                               |
| 12                | 15.00                              | 26.50                         | 4.88                        | 11.12                | R58             | 15.000           | 0.562          | 0.806          | 0.06                       | 1.56                       | 17.75             | 12.75                               |
| 14                | 16.25                              | 29.50                         | 5.25                        | 11.75                | R63             | 16.500           | 0.625          | 1.062          | 0.09                       | 1.75                       | 19.50             | 14.00                               |
| 16                | 18.50                              | 32.50                         | 5.75                        | 12.25                | R67             | 18.500           | 0.688          | 1.188          | 0.09                       | 2.00                       | 21.75             | 16.00                               |
| 18                | 21.00                              | 36.00                         | 6.38                        | 12.88                | R71             | 21.000           | 0.688          | 1.188          | 0.09                       | 2.00                       | 23.50             | 18.00                               |
| 20                | 23.00                              | 38.75                         | 7.00                        | 14.00                | R75             | 23.000           | 0.688          | 1.312          | 0.09                       | 2.12                       | 25.25             | 20.00                               |
| 24                | 27.25                              | 46.00                         | 8.00                        | 16.00                | R79             | 27.250           | 0.812          | 1.438          | 0.09                       | 2.31                       | 30.00             | 24.00                               |

| (1) Nominal Pipe Size | Bore B                    | Diameter of Pressure Connection TT | Drilling Template       |                 |                   |                   | Length of Stud Bolts <sup>(2)(3)</sup> |            |
|-----------------------|---------------------------|------------------------------------|-------------------------|-----------------|-------------------|-------------------|--|------------|
|                       |                           |                                    | Diameter of Bolt Circle | Number of Holes | Diameter of Holes | Diameter of Bolts | Raised Face                            | Ring Joint |
| 1                     | See Note <sup>(4)</sup> . | 1/4                                | 4.00                    | 4               | 1.00              | 7/8               | 6.00                                   | 6.25       |
| 1 1/2                 |                           | 1/4                                | 4.88                    | 4               | 1.12              | 1                 | 6.25                                   | 6.50       |
| 2                     |                           | 1/4                                | 6.50                    | 8               | 1.00              | 7/8               | 6.00                                   | 6.50       |
| 2 1/2                 |                           | 1/4                                | 7.50                    | 8               | 1.12              | 1                 | 6.50                                   | 7.00       |
| 3                     |                           | 3/8                                | 8.00                    | 8               | 1.25              | 1 1/8             | 7.25                                   | 7.25       |
| 4                     |                           | 1/2                                | 9.50                    | 8               | 1.38              | 1 1/4             | 8.00                                   | 8.50       |
| 6                     |                           | 1/2                                | 12.50                   | 12              | 1.50              | 1 3/8             | 10.50                                  | 11.00      |
| 8                     |                           | 1/2                                | 15.50                   | 12              | 1.75              | 1 5/8             | 11.75                                  | 12.25      |
| 10                    |                           | 1/2                                | 19.00                   | 12              | 2.00              | 1 7/8             | 13.50                                  | 14.00      |
| 12                    |                           | 1/2                                | 22.50                   | 16              | 2.12              | 2                 | 15.00                                  | 15.75      |
| 14                    |                           | 1/2                                | 25.00                   | 16              | 2.38              | 2 1/4             | 16.25                                  | 17.52      |
| 16                    |                           | 1/2                                | 27.75                   | 16              | 2.62              | 2 1/2             | 17.75                                  | 19.00      |
| 18                    |                           | 1/2                                | 30.50                   | 16              | 2.88              | 2 3/4             | 19.75                                  | 21.00      |
| 20                    |                           | 1/2                                | 32.75                   | 16              | 3.12              | 3                 | 21.50                                  | 22.50      |
| 24                    |                           | 1/2                                | 39.00                   | 16              | 3.62              | 3 1/2             | 24.50                                  | 26.00      |

(1) All other dimensions are in accordance with ASME B16.5.

(2) Bolt lengths for raised face flanges include allowance for orifice and gasket thickness of 0.25 in. for NPS 1-12 and 0.38 in. for NPS 14-24. Bolt lengths for ring type joint flanges include allowance of 0.62 in. for NPS 1-10, 0.75 in. for NPS 12-18, and 0.88 in. for NPS 20.

(3) In conformance with ASME B16.5, stud bolt lengths do not include point heights.

(4) Bore is to be specified by the purchaser.

# Rosemount DP Flow

Figure 9. Class 2500

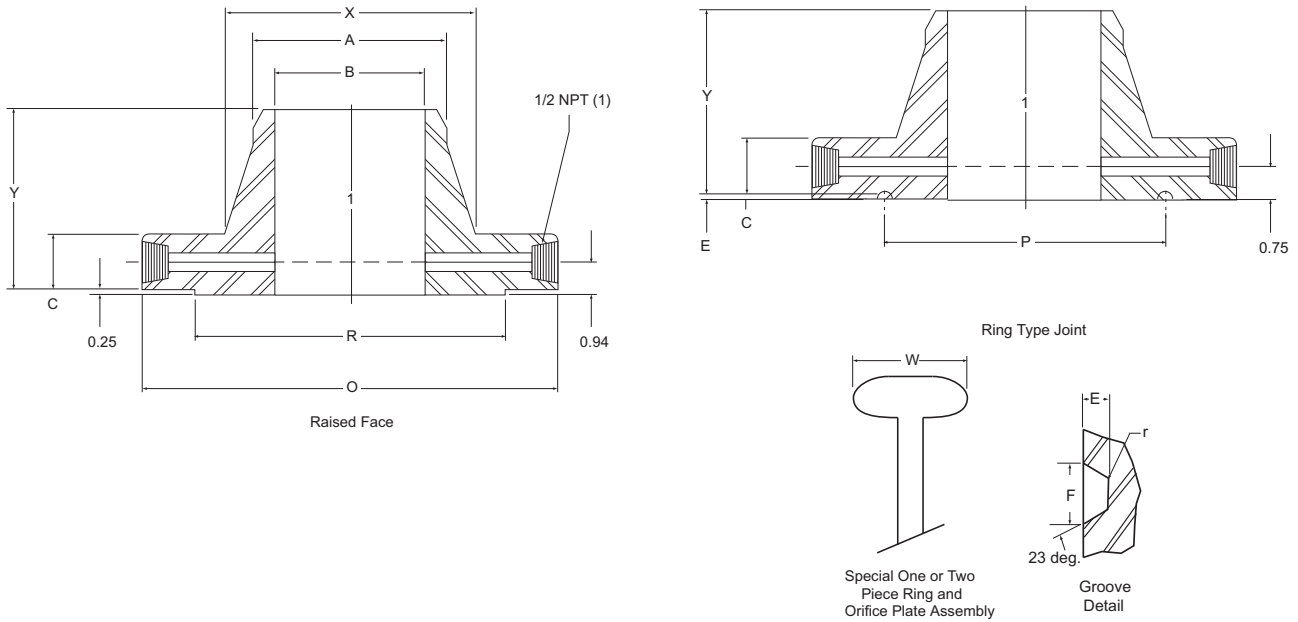

Table 43. Class 2500 Orifice Flanges, Welding Neck<sup>(1)</sup>

| Nominal Pipe Size | Out-side Diameter of Raised Face R | Out-side Diameter of Flange O | Thickness of Flange, Min. C | Length Through Hub Y | Ring Type Joint |                  |                |                |                            |      | Special Oval Ring Height W | Diam-eter of Hub X | Hub Diam-eter Beginning of Chamfer A |
|-------------------|------------------------------------|-------------------------------|-----------------------------|----------------------|-----------------|------------------|----------------|----------------|----------------------------|------|----------------------------|--------------------|--------------------------------------|
|                   |                                    |                               |                             |                      | Groove Number   | Pitch Diameter P | Groove Depth E | Groove Width F | Radius at Bottom $r_{max}$ |      |                            |                    |                                      |
| 1                 | 2.00                               | 6.25                          | 1.50                        | 3.62                 | R18             | 2.375            | 0.250          | 0.344          | 0.03                       | 1.00 | 2.25                       | 1.32               |                                      |
| 1.5               | 2.88                               | 8.00                          | 1.75                        | 4.38                 | R23             | 3.250            | 0.312          | 0.469          | 0.03                       | 1.06 | 3.12                       | 1.90               |                                      |
| 2                 | 3.62                               | 9.25                          | 2.00                        | 5.00                 | R26             | 4.000            | 0.312          | 0.469          | 0.03                       | 1.06 | 3.75                       | 2.38               |                                      |
| 2.5               | 4.12                               | 10.50                         | 2.25                        | 5.62                 | R28             | 4.375            | 0.375          | 0.531          | 0.06                       | 1.19 | 4.50                       | 2.88               |                                      |
| 3                 | 5.00                               | 12.00                         | 2.62                        | 6.62                 | R32             | 5.000            | 0.375          | 0.531          | 0.06                       | 1.19 | 5.25                       | 3.50               |                                      |
| 4                 | 6.19                               | 14.00                         | 3.00                        | 7.35                 | R38             | 6.188            | 0.438          | 0.656          | 0.06                       | 1.31 | 6.50                       | 4.50               |                                      |
| 6                 | 8.50                               | 19.00                         | 4.25                        | 10.75                | R47             | 9.000            | 0.500          | 0.781          | 0.06                       | 1.31 | 6.50                       | 4.50               |                                      |
| 8                 | 10.62                              | 21.75                         | 5.00                        | 12.50                | R51             | 11.000           | 0.562          | 0.906          | 0.06                       | 1.56 | 12.00                      | 8.63               |                                      |
| 10                | 12.75                              | 26.50                         | 6.50                        | 16.50                | R55             | 13.500           | 0.688          | 1.188          | 0.09                       | 1.88 | 14.75                      | 10.75              |                                      |
| 12                | 15.00                              | 30.00                         | 7.25                        | 18.25                | R60             | 16.000           | 0.688          | 1.312          | 0.09                       | 2.00 | 17.38                      | 12.75              |                                      |

**Product Data Sheet**

00813-1000-4485, Rev CA  
November 2011

**Rosemount DP Flow**

| (1)<br>Nominal<br>Pipe<br>Size | Bore B                  | Diameter<br>of<br>Pressure<br>Conn-<br>ection TT | Drilling Template             |                    |                      |                      | Length of Stud Bolts <sup>(2)(3)</sup> |            |
|--------------------------------|-------------------------|--|-------------------------------|--------------------|----------------------|----------------------|--|------------|
|                                |                         |  | Diameter<br>of Bolt<br>Circle | Number of<br>Holes | Diameter<br>of Holes | Diameter<br>of Bolts | Raised Face                            | Ring Joint |
| 1                              | See Note <sup>(4)</sup> | 1/4  | 4.25                          | 4                  | 1.00                 | 7/8                  | 6.00                                   | 6.25       |
| 1.5                            |                         | 1/4  | 5.75                          | 4                  | 1.25                 | 1 1/8                | 7.00                                   | 7.50       |
| 2                              |                         | 1/4  | 6.75                          | 8                  | 1.12                 | 1                    | 7.25                                   | 7.75       |
| 2.5                            |                         | 1/4  | 7.75                          | 8                  | 1.25                 | 1 1/8                | 8.00                                   | 8.50       |
| 3                              |                         | 3/8  | 9.00                          | 8                  | 1.38                 | 1 1/4                | 9.00                                   | 9.50       |
| 4                              |                         | 1/2  | 10.75                         | 8                  | 1.62                 | 1 1/2                | 10.25                                  | 10.75      |
| 6                              |                         | 1/2  | 14.50                         | 8                  | 2.12                 | 2                    | 13.75                                  | 14.50      |
| 8                              |                         | 1/2  | 17.25                         | 12                 | 2.12                 | 2                    | 15.25                                  | 16.00      |
| 10                             |                         | 1/2  | 21.25                         | 12                 | 2.62                 | 2 1/2                | 19.25                                  | 20.25      |
| 12                             |                         | 1/2  | 24.38                         | 12                 | 2.88                 | 2 3/4                | 21.25                                  | 22.50      |

(1) All other dimensions are in accordance with ASME B16.5.

(2) Bolt lengths for raised face flanges include allowance for orifice and gasket thickness of 0.25 in. for NPS 1-12 and 0.38 in. for NPS 14-24. Bolt lengths for ring type joint flanges include allowance of 0.62 in. for NPS 1-10, 0.75 in. for NPS 12-18, and 0.88 in. for NPS 20.

(3) In conformance with ASME B16.5, stud bolt lengths do not include point heights.

(4) Bore is to be specified by the purchaser.

# Rosemount DP Flow

## Pipe I.D. Range Code

For pipes with an Inner Diameter (I.D.) Range / Pipe Wall Thickness not found in this table or with a line size greater than 12-in. (300 mm), choose option code Z and specify the exact pipe dimensions (I.D. and Pipe Wall Thickness) on the Configuration Data Sheet (See document 00806-0100-4010). The Emerson process Management sizing program will determine this code, based on the application piping.

|                                    | Line Size                  |                          |  | Inner Diameter (I.D.) Range              | Pipe Wall Thickness                    |                                     | I.D. Range Code |
|------------------------------------|----------------------------|--------------------------|--|--|--|-------------------------------------|-----------------|
|                                    | Nominal                    | Max. O.D.                | Option Code                                |  | ANSI Pipes                             | Non-ANSI Pipes                      |                 |
|                                    | 2-in.<br>(50 mm)           | 2.625-in.<br>(66.68 mm)  | 020  | 1.784 to 1.841-in. (45.31 to 46.76 mm)   | 0.065 to 0.545-in.<br>(1.7 to 13.8 mm) | 0.065 to 0.488-in. (1.7 to 12.4 mm) | A               |
|                                    |                            |                          |  | 1.842 to 1.938-in. (46.79 to 49.23 mm)   |  | 0.065 to 0.449-in. (1.7 to 11.4 mm) | B               |
|                                    |                            |                          |  | 1.939 to 2.067-in. (49.25 to 52.50 mm)   |  | 0.065 to 0.417-in. (1.7 to 10.6 mm) | C               |
|                                    |                            |                          |  | 2.068 to 2.206-in. (52.53 to 56.03 mm)   |  | 0.065 to 0.407-in. (1.7 to 10.3 mm) | D               |
|                                    | 2 1/2-in.<br>(63.5 mm)     | 3.188-in.<br>(80.98 mm)  | 025  | 2.207 to 2.322-in. (56.06 to 58.98 mm)   | 0.083 to 0.563-in.<br>(2.1 to 14.3 mm) | 0.083 to 0.448-in. (2.1 to 11.4 mm) | B               |
|                                    |                            |                          |  | 2.323 to 2.469-in. (59.00 to 62.71 mm)   |  | 0.083 to 0.417-in. (2.1 to 10.6 mm) | C               |
|                                    |                            |                          |  | 2.470 to 2.598-in. (62.74 to 65.99 mm)   |  | 0.083 to 0.435-in. (2.1 to 11.0 mm) | D               |
|                                    |                            |                          |  | 2.599 to 2.647-in. (66.01 to 67.23 mm)   |  | 0.083 to 0.515-in. (2.1 to 13.1 mm) | E               |
|                                    | 3-in.<br>(80 mm)           | 3.75-in.<br>(95.25 mm)   | 030  | 2.648 to 2.751-in. (67.26 to 69.88 mm)   | 0.083 to 0.563-in.<br>(2.1 to 14.3 mm) | 0.083 to 0.460-in. (2.1 to 11.7 mm) | A               |
|                                    |                            |                          |  | 2.752 to 2.899-in. (69.90 to 73.63 mm)   |  | 0.083 to 0.416-in. (2.1 to 10.6 mm) | B               |
|                                    |                            |                          |  | 2.900 to 3.068-in. (73.66 to 77.93 mm)   |  | 0.083 to 0.395-in. (2.1 to 10.0 mm) | C               |
|                                    |                            |                          |  | 3.069 to 3.228-in. (77.95 to 81.99 mm)   |  | 0.083 to 0.404-in. (2.1 to 10.3 mm) | D               |
|                                    | 3 1/2-in.<br>(89 mm)       | 4.25-in.<br>(107.95 mm)  | 035  | 3.229 to 3.333-in. (82.02 to 84.66 mm)   | 0.120 to 0.600-in.<br>(3.0 to 15.2 mm) | 0.120 to 0.496-in. (3.0 to 12.6 mm) | B               |
|                                    |                            |                          |  | 3.334 to 3.548-in. (84.68 to 90.12 mm)   |  | 0.120 to 0.386-in. (3.0 to 9.8 mm)  | C               |
|                                    |                            |                          |  | 3.549 to 3.734-in. (90.14 to 94.84 mm)   |  | 0.120 to 0.415-in. (3.0 to 10.5 mm) | D               |
|                                    |                            |                          |  | 3.735 to 3.825-in. (94.87 to 97.16 mm)   |  | 0.120 to 0.510-in. (3.0 to 13.0 mm) | B               |
|                                    | 4-in.<br>(100 mm)          | 5.032-in.<br>(127.81 mm) | 040  | 3.826 to 4.026-in. (97.18 to 102.26 mm)  | 0.120 to 0.600-in.<br>(3.0 to 15.2 mm) | 0.120 to 0.400-in. (3.0 to 10.2 mm) | C               |
|                                    |                            |                          |  | 4.027 to 4.237-in. (102.29 to 107.62 mm) |  | 0.120 to 0.390-in. (3.0 to 9.9 mm)  | D               |
|                                    |                            |                          |  | 4.238 to 4.437-in. (107.65 to 112.70 mm) |  | 0.120 to 0.401-in. (3.0 to 10.2 mm) | E               |
|                                    |                            |                          |  | 4.438 to 4.571-in. (112.73 to 116.10 mm) |  | 0.134 to 0.481-in. (3.4 to 12.2 mm) | A               |
|                                    | 5-in.<br>(125 mm)          | 6.094-in.<br>(154.79 mm) | 050  | 4.572 to 4.812-in. (116.13 to 122.22 mm) | 0.134 to 0.614-in.<br>(3.4 to 15.6 mm) | 0.134 to 0.374-in. (3.4 to 9.5 mm)  | B               |
|                                    |                            |                          |  | 4.813 to 5.047-in. (122.25 to 128.19 mm) |  | 0.134 to 0.380-in. (3.4 to 9.7 mm)  | C               |
|                                    |                            |                          |  | 5.048 to 5.249-in. (128.22 to 133.32 mm) |  | 0.134 to 0.413-in. (3.4 to 10.5 mm) | D               |
|                                    |                            |                          |  | 5.250 to 5.472-in. (133.35 to 138.99 mm) |  | 0.134 to 0.3919-in. (3.4 to 9.9 mm) | A               |
| Sensor Size 1<br>6-in.<br>(150 mm) | 6.93-in.<br>(176.02 mm)    | 060                      | 5.473 to 5.760-in. (139.01 to 146.30 mm)   | 0.134 to 0.614-in.<br>(3.4 to 15.6 mm)   | 0.134 to 0.327-in. (3.4 to 8.3 mm)     | B                                   |                 |
|                                    |                            |                          | 5.761 to 6.065-in. (146.33 to 154.05 mm)   |  | 0.134 to 0.31-in. (3.4 to 7.9 mm)      | C                                   |                 |
|                                    |                            |                          | 6.066 to 6.383-in. (154.08 to 162.13 mm)   |  | 0.134 to 0.297-in. (3.4 to 7.5 mm)     | D                                   |                 |
|                                    |                            |                          | 5.250 to 5.472-in. (133.35 to 139.99 mm)   |  | 0.134 to 1.132-in. (3.4 to 28.7 mm)    | A                                   |                 |
| Sensor Size 2<br>6-in.<br>(150 mm) | 6.93-in.<br>(176.02 mm)    | 060                      | 5.473 to 5.760-in. (139.01 to 146.30 mm)   | 0.134 to 1.354-in.<br>(3.4 to 34.4 mm)   | 0.134 to 1.067-in. (3.4 to 27.1 mm)    | B                                   |                 |
|                                    |                            |                          | 5.761 to 6.065-in. (146.33 to 154.05 mm)   |  | 0.134 to 1.05-in. (3.4 to 26.7 mm)     | C                                   |                 |
|                                    |                            |                          | 6.066 to 6.383-in. (154.08 to 162.13 mm)   |  | 0.134 to 1.037-in. (3.4 to 26.3 mm)    | D                                   |                 |
|                                    |                            |                          | 6.384 to 6.624-in. (162.15 to 168.25 mm)   |  | 0.134 to 0.374-in. (3.4 to 9.5 mm)     | B                                   |                 |
| Sensor Size 1<br>7-in.<br>(180 mm) | 7.93-in.<br>(201.42 mm)    | 070                      | 6.625 to 7.023-in. (168.28 to 178.38 mm)   | 0.134 to 0.614-in.<br>(3.4 to 15.6 mm)   | 0.134 to 0.216-in. (3.4 to 5.5 mm)     | C                                   |                 |
|                                    |                            |                          | 7.024 to 7.392-in. (178.41 to 187.76 mm)   |  | 0.134 to 0.246-in. (3.4 to 6.2 mm)     | D                                   |                 |
|                                    |                            |                          | 6.384 to 6.624-in. (162.15 to 168.25 mm)   |  | 0.134 to 1.114-in. (3.4 to 28.3 mm)    | B                                   |                 |
|                                    |                            |                          | 6.625 to 7.023-in. (168.28 to 178.38 mm)   |  | 0.134 to 0.956-in. (3.4 to 24.3 mm)    | C                                   |                 |
| Sensor Size 2<br>7-in.<br>(180 mm) | 7.93-in.<br>(201.42 mm)    | 070                      | 7.024 to 7.392-in. (178.41 to 187.76 mm)   | 0.134 to 1.354-in.<br>(3.4 to 34.4 mm)   | 0.134 to 0.986-in. (3.4 to 25.0 mm)    | D                                   |                 |
|                                    |                            |                          | 7.393 to 7.624-in. (187.78 to 193.65 mm)   |  | 0.250 to 0.499-in. (6.4 to 12.6 mm)    | B                                   |                 |
|                                    |                            |                          | 7.625 to 7.981-in. (193.68 to 202.72 mm)   |  | 0.250 to 0.374-in. (6.4 to 9.5 mm)     | C                                   |                 |
|                                    |                            |                          | 7.982 to 8.400-in. (202.74 to 213.36 mm)   |  | 0.250 to 0.312-in. (6.4 to 7.9 mm)     | D                                   |                 |
| Sensor Size 1<br>8-in.<br>(200 mm) | 9.688-in.<br>(246.08 mm)   | 080                      | 8.401 to 8.766-in. (213.39 to 222.66 mm)   | 0.250 to 0.73-in.<br>(6.4 to 18.5 mm)    | 0.250 to 0.364-in. (6.4 to 9.2 mm)     | E                                   |                 |
|                                    |                            |                          | 7.393 to 7.624-in. (187.78 to 193.65 mm)   |  | 0.250 to 1.239-in. (6.4 to 31.4 mm)    | B                                   |                 |
|                                    |                            |                          | 7.625 to 7.981-in. (193.68 to 202.72 mm)   |  | 0.250 to 1.114-in. (6.4 to 28.3 mm)    | C                                   |                 |
|                                    |                            |                          | 7.982 to 8.400-in. (202.74 to 213.36 mm)   |  | 0.250 to 1.052-in. (6.4 to 26.7 mm)    | D                                   |                 |
| Sensor Size 2<br>8-in.<br>(200 mm) | 9.688-in.<br>(246.08 mm)   | 080                      | 8.401 to 8.766-in. (213.39 to 222.66 mm)   | 0.250 to 1.47-in.<br>(6.4 to 37.3 mm)    | 0.250 to 1.104-in. (6.4 to 28.0 mm)    | E                                   |                 |
|                                    |                            |                          | 8.767 to 9.172-in. (222.68 to 232.97 mm)   |  | 0.250 to 1.065-in. (6.4 to 27.1 mm)    | A                                   |                 |
|                                    |                            |                          | 9.173 to 9.561-in. (232.99 to 242.85 mm)   |  | 0.250 to 1.082-in. (6.4 to 27.5 mm)    | B                                   |                 |
|                                    |                            |                          | 9.562 to 10.020-in. (242.87 to 254.51 mm)  |  | 0.250 to 1.012-in. (6.4 to 25.7 mm)    | C                                   |                 |
| 10-in.<br>(250 mm)                 | 11.75-in.<br>(298.45 mm)   | 100                      | 10.021 to 10.546-in. (254.53 to 267.87 mm) | 0.250 to 1.470-in.<br>(6.4 to 37.3 mm)   | 0.250 to 0.945-in. (6.4 to 24.0 mm)    | D                                   |                 |
|                                    |                            |                          | 10.547 to 10.999-in. (267.89 to 279.37 mm) |  | 0.250 to 1.018-in. (6.4 to 25.9 mm)    | E                                   |                 |
|                                    |                            |                          | 11.000 to 11.373-in. (279.40 to 288.87 mm) |  | 0.250 to 1.097-in. (6.4 to 27.9 mm)    | B                                   |                 |
|                                    |                            |                          | 11.374 to 11.938-in. (288.90 to 303.23 mm) |  | 0.250 to 0.906-in. (6.4 to 23.0 mm)    | C                                   |                 |
| 12-in.<br>(300 mm)                 | 13.0375-in.<br>(331.15 mm) | 120                      | 11.939 to 12.250-in. (303.25 to 311.15 mm) | 0.250 to 1.470-in.<br>(6.4 to 37.3 mm)   | 0.250 to 1.159-in. (6.4 to 29.4 mm)    | D                                   |                 |



# Rosemount DP Flow

**Product Data Sheet**  
00813-1000-4485, Rev CA  
November 2011

*Standard Terms and Conditions of Sale can be found at [www.rosemount.com/terms\\_of\\_sale](http://www.rosemount.com/terms_of_sale)  
The Emerson logo is a trade mark and service mark of Emerson Electric Co.  
Rosemount, the Rosemount logotype, ProBar, Mass ProBar and Annubar are registered trademarks of Rosemount Inc.  
MultiVariable (MV) and Tri-Loop are trademarks of Rosemount Inc.  
HART is a registered trademark of the HART Communication Foundation.  
FOUNDATION is a trademark of the Fieldbus Foundation.  
All other marks are the property of their respective owners.  
© 2011 Rosemount, Inc. All rights reserved.*

**Emerson Process Management  
Rosemount Measurement**  
8200 Market Boulevard  
Chanhassen MN 55317 USA  
Tel (USA) 1 800 999 9307  
Tel (International) +1 952 906 8888  
Fax +1 952 949 7001

**Emerson Process Management**  
Blegistrasse 23  
P.O. Box 1046  
CH 6341 Baar  
Switzerland  
Tel +41 (0) 41 768 6111  
Fax +41 (0) 41 768 6300

**Emerson FZE**  
P.O. Box 17033  
Jebel Ali Free Zone  
Dubai UAE  
Tel +971 4 811 8100  
Fax +971 4 886 5465

**Emerson Process Management Asia Pacific  
Pte Ltd**  
1 Pandan Crescent  
Singapore 128461  
Tel +65 6777 8211  
Fax +65 6777 0947  
Service Support Hotline : +65 6770 8711  
Email : [Enquiries@AP.EmersonProcess.com](mailto:Enquiries@AP.EmersonProcess.com)