

Rosemount™ 499ACL-01

Free Chlorine Sensor



Safety information

⚠ CAUTION

Sensor/process application compatibility

The wetted sensor materials may not be compatible with process composition and operating conditions.

Application compatibility is entirely the operator's responsibility.

⚠ CAUTION

Equipment damage

Do not exceed pressure and temperature specifications

Pressure: 65 psig (549 kPa abs) max.

Temperature: 32 to 122 °F (0 to 50 °C)

⚠ WARNING

Physical access

Unauthorized personnel may potentially cause significant damage to and/or misconfiguration of end users' equipment. This could be intentional or unintentional and needs to be protected against.

Physical security is an important part of any security program and fundamental to protecting your system. Restrict physical access by unauthorized personnel to protect end users' assets. This is true for all systems used within the facility.

Notice

ROSEMOUNT ("SELLER") SHALL NOT BE LIABLE FOR TECHNICAL OR EDITORIAL ERRORS IN THIS MANUAL OR OMISSIONS FROM THIS MANUAL. SELLER MAKES NO WARRANTIES, EXPRESSED OR IMPLIED, INCLUDING THE IMPLIED WARRANTIES OF MERCHANTABILITY AND FITNESS FOR A PARTICULAR PURPOSE, WITH RESPECT TO THIS MANUAL AND, IN NO EVENT, SHALL SELLER BE LIABLE FOR ANY SPECIAL OR CONSEQUENTIAL DAMAGES INCLUDING, BUT NOT LIMITED TO, LOSS OF PRODUCTION, LOSS OF PROFITS, ETC.

PRODUCT NAMES USED HEREIN ARE FOR MANUFACTURER OR SUPPLIER IDENTIFICATION ONLY AND MAY BE TRADEMARKS/REGISTERED TRADEMARKS OF THESE COMPANIES.

THE CONTENTS OF THIS PUBLICATION ARE PRESENTED FOR INFORMATIONAL PURPOSES ONLY, AND WHILE EVERY EFFORT HAS BEEN MADE TO ENSURE THEIR ACCURACY, THEY ARE NOT TO BE CONSTRUED AS WARRANTIES OR GUARANTEES, EXPRESSED OR IMPLIED, REGARDING THE PRODUCTS OR SERVICES DESCRIBED HEREIN OR THEIR USE OR APPLICABILITY. WE RESERVE THE RIGHT TO MODIFY OR IMPROVE THE DESIGNS OR SPECIFICATIONS OF SUCH PRODUCTS AT ANY TIME.

SELLER DOES NOT ASSUME RESPONSIBILITY FOR THE SELECTION, USE, OR MAINTENANCE OF ANY PRODUCT. RESPONSIBILITY FOR PROPER SELECTION, USE, AND MAINTENANCE OF ANY SELLER PRODUCT REMAINS SOLELY WITH THE PURCHASER AND END-USER.

Warranty

1. **LIMITED WARRANTY:** Subject to the limitations contained in Section 2 herein and except as otherwise expressly provided herein, Rosemount ("Seller") warrants that the firmware will execute the programming instructions provided by Seller and that the Goods manufactured or Services provided by Seller will be free from defects in materials or workmanship under normal use and care until the expiration of the applicable warranty period. Goods are warranted for twelve (12) months from the date of initial installation or eighteen (18) months from the date of shipment by Seller, whichever period expires first. Consumables and

Services are warranted for a period of 90 days from the date of shipment or completion of the Services. Products purchased by Seller from a third party for resale to Buyer ("Resale Products") shall carry only the warranty extended by the original manufacturer. Buyer agrees that Seller has no liability for Resale Products beyond making a reasonable commercial effort to arrange for procurement and shipping of the Resale Products. If Buyer discovers any warranty defects and notifies Seller thereof in writing during the applicable warranty period, Seller shall, at its option, promptly correct any errors that are found by Seller in the firmware or Services, or repair or replace F.O.B. point of manufacture that portion of the Goods or firmware found by Seller to be defective, or refund the purchase price of the defective portion of the Goods/Services. All replacements or repairs necessitated by inadequate maintenance, normal wear and usage, unsuitable power sources, unsuitable environmental conditions, accident, misuse, improper installation, modification, repair, storage or handling, or any other cause not the fault of Seller are not covered by this limited warranty, and shall be at Buyer's expense. Seller shall not be obligated to pay any costs or charges incurred by Buyer or any other party except as may be agreed upon in writing in advance by an authorized Seller representative. All costs of dismantling, reinstallation and freight, and the time and expenses of Seller's personnel for site travel and diagnosis under this warranty clause shall be borne by Buyer unless accepted in writing by Seller. Goods repaired and parts replaced during the warranty period shall be in warranty for the remainder of the original warranty period or ninety (90) days, whichever is longer. This limited warranty is the only warranty made by Seller and can be amended only in a writing signed by an authorized representative of Seller. Except as otherwise expressly provided in the Agreement, THERE ARE NO REPRESENTATIONS OR WARRANTIES OF ANY KIND, EXPRESSED OR IMPLIED, AS TO MERCHANTABILITY, FITNESS FOR PARTICULAR PURPOSE, OR ANY OTHER MATTER WITH RESPECT TO ANY OF THE GOODS OR SERVICES. It is understood that corrosion or erosion of materials is not covered by our guarantee.

2. **LIMITATION OF REMEDY AND LIABILITY:** SELLER SHALL NOT BE LIABLE FOR DAMAGES CAUSED BY DELAY IN PERFORMANCE. THE SOLE AND EXCLUSIVE REMEDY FOR BREACH OF WARRANTY HEREUNDER SHALL BE LIMITED TO REPAIR, CORRECTION, REPLACEMENT, OR REFUND OF PURCHASE PRICE UNDER THE LIMITED WARRANTY CLAUSE IN SECTION 1 HEREIN. IN NO EVENT, REGARDLESS OF THE FORM OF THE CLAIM OR CAUSE OF ACTION (WHETHER BASED IN CONTRACT, INFRINGEMENT, NEGLIGENCE, STRICT LIABILITY, OTHER TORT, OR OTHERWISE), SHALL SELLER'S LIABILITY TO BUYER AND/OR ITS CUSTOMERS EXCEED THE PRICE TO BUYER OF THE SPECIFIC GOODS MANUFACTURED OR SERVICES PROVIDED BY SELLER GIVING RISE TO THE CLAIM OR CAUSE OF ACTION. BUYER AGREES THAT IN NO EVENT SHALL SELLER'S LIABILITY TO BUYER AND/OR ITS CUSTOMERS EXTEND TO INCLUDE INCIDENTAL, CONSEQUENTIAL OR PUNITIVE DAMAGES. THE TERM "CONSEQUENTIAL DAMAGES" SHALL INCLUDE, BUT NOT BE LIMITED TO, LOSS OF ANTICIPATED PROFITS, LOSS OF USE, LOSS OF REVENUE, AND COST OF CAPITAL.

Contents

First steps.....	5
Install.....	8
Wire.....	12
Calibrate.....	17
Maintenance.....	19
Accessories.....	22

1 First steps

1.1 Unpack and inspect

Procedure

1. Inspect the shipping container. If it is damaged, contact the shipper immediately for instructions.
2. If there is no apparent damage, unpack the container. Be sure all items shown on the packing list are present. If items are missing, notify Emerson immediately.

1.2 Product description

Figure 1-1: Rosemount 499ACL-01 Sensor Parts

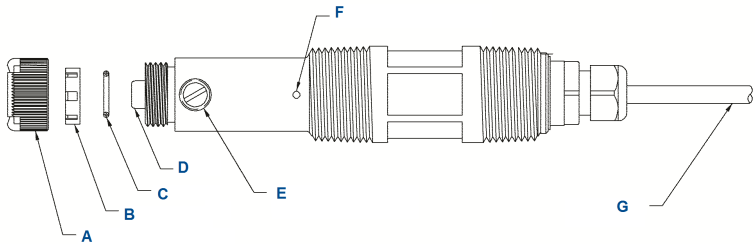

- A. Membrane retainer
- B. Membrane assembly
- C. O-ring
- D. Cathode
- E. Electrolyte fill plug (wrap with pipe tape)
- F. Pressure equalizing port
- G. Sensor cable (integral cable shown)

1.3 Specifications

Table 1-1: Sensor Specifications

Physical characteristics	Specifications
Range	0 to 10 ppm (mg/L) as Cl ₂ . For higher ranges, consult the factory.
Pressure	0 to 65 psig (101 to 549 kPa abs)
Temperature (operating)	32 to 122 °F (0 to 50 °C)
Process connection	1-in. male national pipe thread (MNPT)

Table 1-1: Sensor Specifications (continued)

Physical characteristics	Specifications
Wetted parts	Noryl®, Viton®, platinum, polyethersulfone, polyester, wood, and silicone
Accuracy	Accuracy depends on the accuracy of the chemical test used to calibrate the sensor.
pH range	6.0 to 9.5. For samples having pH between 9.5 and 10.0, consult the factory. Samples with ranges below 6.0 require no pH correction.
pH correction	Use continuous pH correction (requires an auxiliary pH sensor) if sample pH varies more than 0.2 pH (peak to peak). If pH variability is less or seasonal, the pH sensor is generally not required.
Linearity	2% (typical)
Sample conductivity	> 50 μ S/cm
Interferences	Peroxides, permanganate, and chloramines
Response time	22 sec to 95% of final reading at 77 °F (25 °C)
Electrolyte volume	0.8 oz. (25 mL), approximately
Electrolyte life	3 months (approximately); for best results, replace electrolyte monthly.
Cable length	See <i>Ordering information</i> table in the Product Data Sheet for cable length options.
Sample flow	Flow through: 2 to 5 gpm (3.8 to 19 L/min) Open channel: 1 ft./sec (0.3 m/sec) Low flow cell (PN 24091-00): 8 to 15 gph (30 to 57 L/hr) Low flow cell (PN 24091-01): 2 to 5 gph (7.6 to 19 L/hr)
Weight/shipping weight	1 lb./3 lb. (0.5 kg/1.5 kg)

Table 1-2: Other Specifications

Type	PN	Wetted materials	Process connection	Maximum temperature	Maximum pressure
1½-in. tee	23567-00	CPVC and Buna N	1½-in. socket	122 °F (50 °C)	65 psig (549 kPa abs)
2-in. tee	915240-03	PVC and Buna N	¾-in. NFPT	120 °F (49 °C)	60 psig (515 kPa abs)
	915240-04		1-in. NFPT		
	915240-05		1½-in. NFPT		

Table 1-2: Other Specifications (continued)

Type	PN	Wetted materials	Process connection	Maximum temperature	Maximum pressure
Low flow cell ⁽¹⁾	24091-00 and 24091-01	Polycarbonate/ polyester, 316 stainless steel, and silicone	Compression fitting for ¼-in. O.D. tubing	158 °F (70 °C)	90 psig (722 kPa abs)

(1) *Temperature and pressure specifications for the low flow cell exceed the temperature and pressure specifications for the sensor.*

2 Install

Install the sensor in a flowing sample. Keep the sample flow as constant as possible at a value within the following limits:

Sample flow unit	Flow limits
Flow through	1 to 5 gpm (3.8 to 19 L/min)
Open channel	1 ft/sec (0.3 m/sec)
Low flow cell (PN 24091-00)	8 to 15 gph (20 to 47 L/hr)
Low flow cell (PN 24091-01)	2 to 3 gph (120 to 190 mL/min)

Figure 2-1: Sensor Orientation

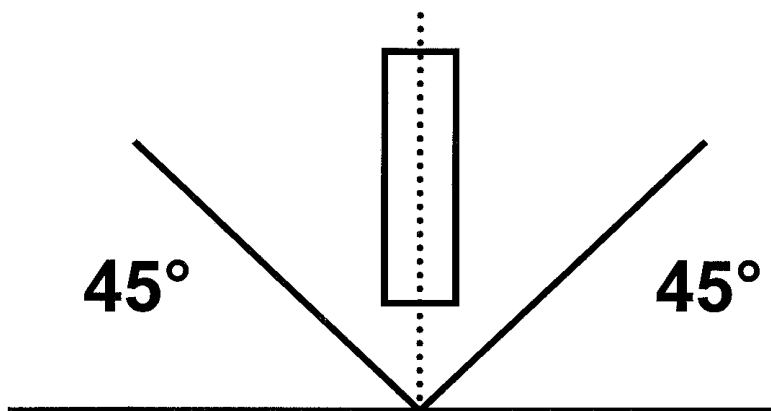

Install sensor within 45 degrees of vertical.

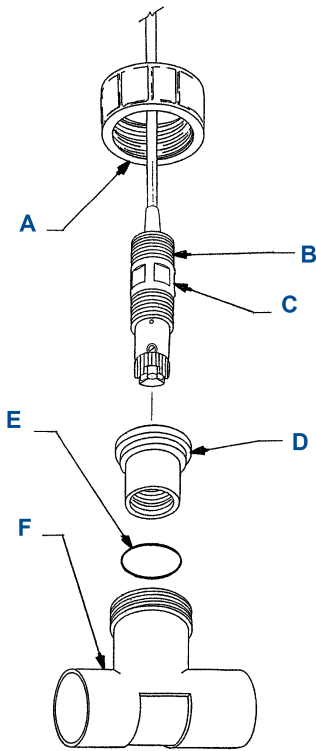
Figure 2-2: Flow Through 1½-in. Tee

- A. Union coupler
- B. 1-in. national pipe thread (NPT), two places
- C. Sensor body: Rosemount 499A
- D. 1-in. NPT flow cell adapter
- E. O-ring 2-222
- F. 1½-in. sched 80 CPVC tee body

Figure 2-3: Flow Through 2-in. Tee

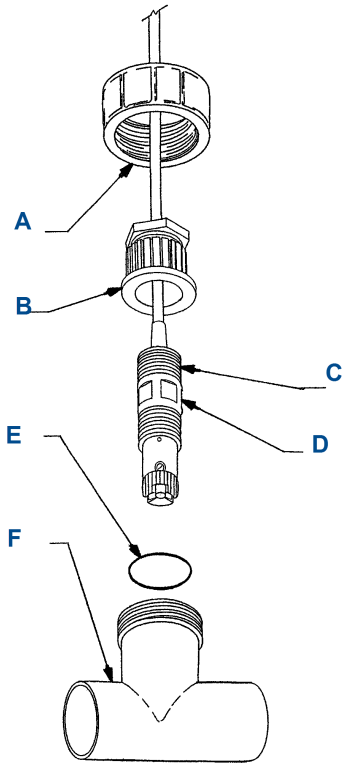

- A. Union coupler
- B. Adapter
- C. 1-in. NPT (two places)
- D. Sensor body: Rosemount 499A
- E. O-ring 2-222
- F. 2-in. sched 80 PVC tee body

Figure 2-4: Low Flow Cell (PN 24091-00)

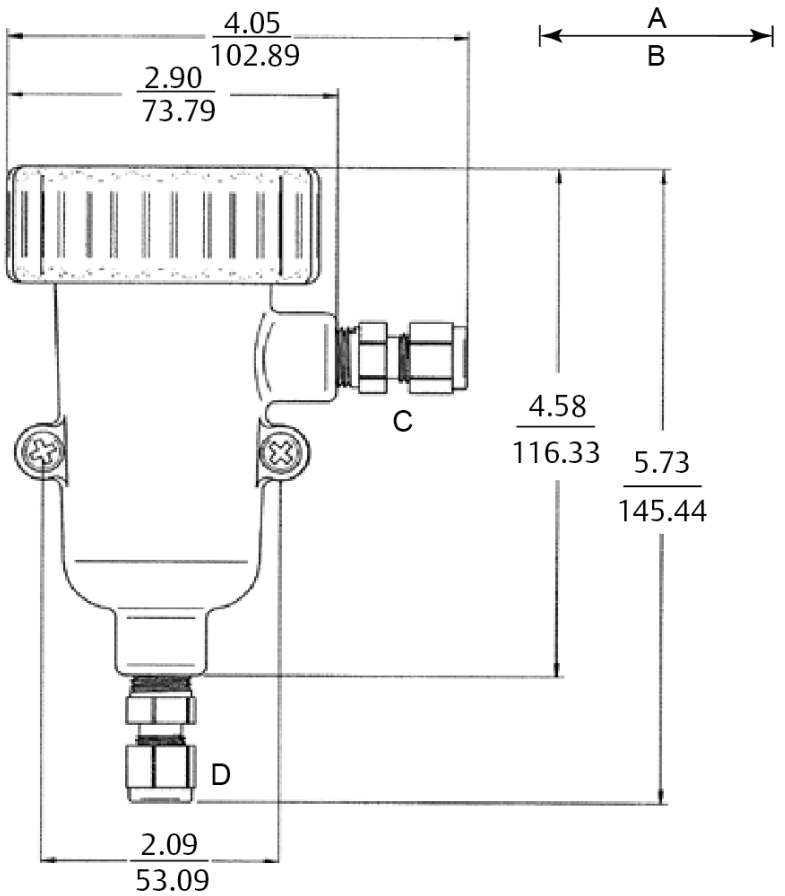

- A. Inches
- B. Millimeters
- C. Outlet
- D. Inlet

3 Wire

NOTICE

For additional wiring information on this product, including sensor combinations not shown here, please refer to the [Liquid Transmitter Wiring Diagrams](#).

Figure 3-1: Rosemount 499ACL-01 Sensor Wiring to Rosemount 1056 and 56 Transmitters

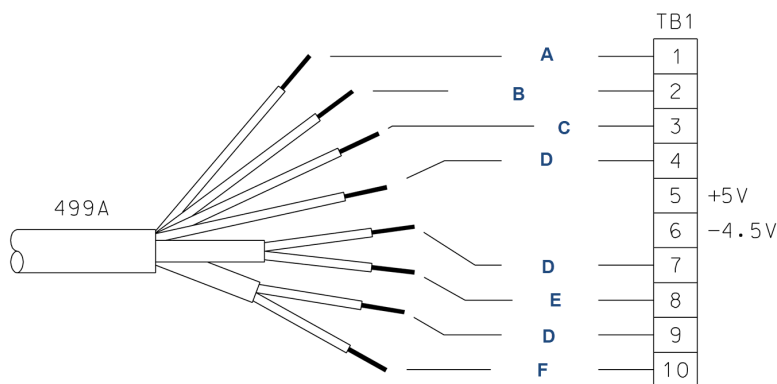

Table 3-1: Rosemount 499ACL-01 Sensor Wiring to Rosemount 1056 and 56 Transmitters

Terminal number	Letter	Wire color	Description
1	A	White	Resistance temperature device (RTD) return
2	B	White/red	RTD sense
3	C	Red	RTD in
4	D	Clear	RTD shield
5	N/A	N/A	+5 V out
6	N/A	N/A	-4.5 V out
7	D	Clear	Anode shield
8	E	Gray	Anode
9	D	Clear	Cathode shield

Table 3-1: Rosemount 499ACL-01 Sensor Wiring to Rosemount 1056 and 56 Transmitters (continued)

Terminal number	Letter	Wire color	Description
10	F	Orange	Cathode

Figure 3-2: Rosemount 499ACL-01 Sensor Wiring to Rosemount 5081 Transmitter

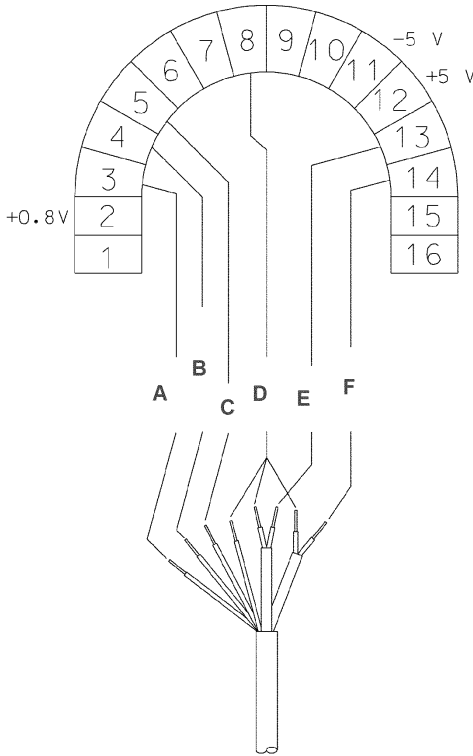

Table 3-2: Rosemount 499ACL-01 Sensor Wiring to Rosemount 5081 Transmitter

Terminal number	Letter	Wire color	Description
1	N/A	N/A	N/A
2	N/A	N/A	+0.8 V
3	A	White	RTD return

Table 3-2: Rosemount 499ACL-01 Sensor Wiring to Rosemount 5081 Transmitter (continued)

Terminal number	Letter	Wire color	Description
4	B	White/red	RTD sense
5	C	Red	RTD in
6	N/A	N/A	Reference guard
7	N/A	N/A	Reference in
8	D	Clear	Solution ground
9	N/A	N/A	pH guard
10	N/A	N/A	pH in
11	N/A	N/A	-5 V
12	N/A	N/A	+5 V
13	E	Gray	Anode
14	F	Orange	Cathode
15	N/A	N/A	HART®/FOUNDATION™ Fieldbus (-)
16	N/A	N/A	HART/FOUNDATION Fieldbus (+)

Figure 3-3: Rosemount 499ACL-01 Sensor Wiring to Rosemount 1066 Transmitter

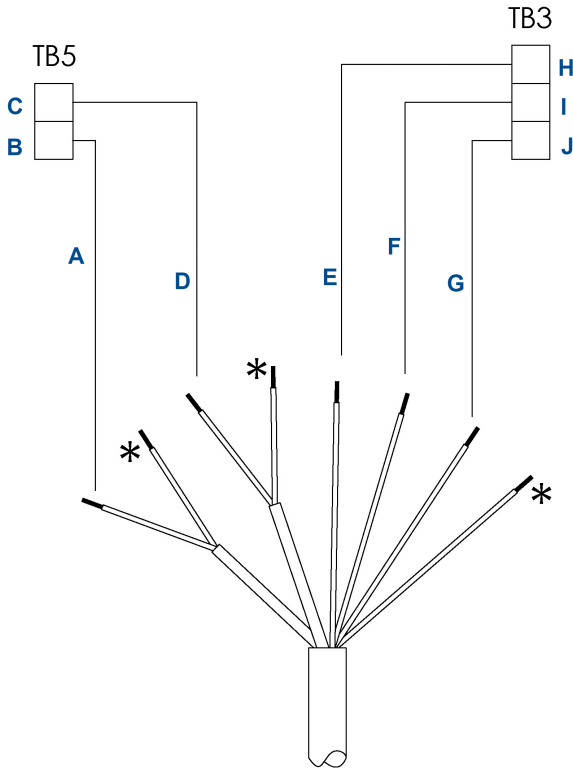

Note

Connect clear shield wires to solution ground terminal on TB 2. Use wire nut and pigtail if necessary.

- A. Orange
- B. Cathode
- C. Anode
- D. Gray
- E. White
- F. White/red
- G. Red
- H. Return
- I. Sense
- J. RTD in

Figure 3-4: Rosemount 499ACL-01-01-54-VP Sensor Pin-out Diagram (Top View of Connector End of Sensor)

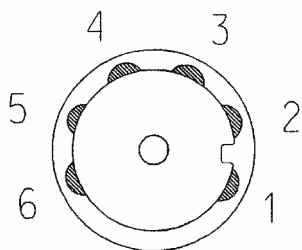

Table 3-3: Pin-out Diagram

Terminal number	Description
1	Cathode
2	N/A
3	RTD sense
4	Anode
5	RTD return
6	RTD in

When making a connection through a junction box (PN 23550-00), wire point-to-point.

NOTICE

Use a wire nut and pigtail (included) when connecting several wires to the same terminal.

4 Calibrate

4.1 Zero point calibration

Even in the absence of free chlorine, the sensor generates a small signal called the zero current. Failing to correct for the zero current can introduce a bias, particularly if the chlorine concentration is small (<0.4 ppm). Zero the sensor when it is first placed in service and every time the fill solution is changed.

To zero the sensor:

Procedure

1. Pour a cup of deionized or bottled water.
2. Add a few pinches of table salt to the water to increase the conductivity.
3. Place the sensor in the water.
4. Wait until the sensor current has reached a stable low value (at least two hours).
5. Follow the transmitter prompts for zeroing the sensor.

Note

Refer to the manual for the transmitter you are using (Rosemount 56, 1056, 5081, or 1066).

The zero current should be between -10 and +10 nA. For more information, refer to the transmitter manual.

4.2 Full scale calibration

Because stable dilute chlorine standards are not available, the sensor must be calibrated against the results of a laboratory test run on a grab sample of the process liquid.

Be sure taking the sample does not alter flow to the sensor and test the sample immediately after taking it.

Procedure

1. Place the sensor in the flow cell.
2. Start the sample and reagent flow.
3. Adjust the sample flow to within the range given in the table in [Install](#).
4. Adjust the concentration so that it is near the upper end of the operating range.
5. Wait for the readings to stabilize.

6. Follow the transmitter prompts to complete the calibration.

Note

Refer to the manual for the transmitter you are using (Rosemount 56, 1056, 5081, or 1066).

7. After calibration, go to the **Diagnostics** menu and check the sensitivity.

The sensitivity should be between 300 and 700 nA/ppm. For more information, refer to the transmitter manual.

5 Maintenance

Periodic maintenance and cleaning are required for best performance of the sensor. Generally, the membrane and fill solution should be replaced every one to three months. If the sensor is being used in water having conductivity less than about 100 $\mu\text{S}/\text{cm}$, it might be necessary to replace the fill solution (but not the membrane) more often. Sensors installed in harsh or dirty environments require more frequent maintenance. The optimum maintenance frequency is best determined by experience.

▲ WARNING

Pressurized spray injury

Before removing the sensor, be absolutely certain that the process pressure is reduced to 0 psig and the process temperature is lowered to a safe level!

5.1 Cleaning the membrane

Keep the membrane clean and free from dirt and algae. Clean the membrane with water sprayed from a wash bottle. **Do not use tissues to clean the membrane.**

5.2 Replacing the electrolyte solution and membrane

▲ WARNING

Harmful substance

Fill solution may cause irritation. May be harmful if swallowed.

Read and follow the instructions.

Procedure

1. Unscrew the membrane retainer.
2. Remove the membrane assembly and O-ring.
See [Figure 1-1](#).
3. Hold the sensor over a container with the cathode pointing down.
4. Remove the fill plug.
5. Allow the electrolyte solution to drain out.
6. Inspect the cathode.
 - a) If it is tarnished, clean it using a cotton-tipped swab dipped in baking soda or alumina.

Use type A dry powder alumina intended for metallographic polishing of medium and soft metals.

- b) Rinse thoroughly with water.
7. Remove the old pipe tape from the plug.
 8. Wrap the plug with one or two turns of pipe tape..
 9. Prepare a new membrane.
 - a) Hold the membrane assembly with the cup formed by the membrane and membrane holder pointing up.
 - b) Fill the cup with electrolyte solution.
 - c) Wait for the wooden ring to soak up the solution.
This usually takes several minutes.
 10. Hold the sensor at about a 45 degree angle with the cathode end pointing up.
 11. Add electrolyte solution through the fill hole until the liquid overflows.
 12. Tap the sensor near the threads to release trapped air bubbles.
 13. Add more electrolyte solution if necessary.
 14. Place the fill plug in the electrolyte port and begin screwing it in.
 15. After several threads have engaged, rotate the sensor so that the cathode is pointing up and continue tightening the fill plug.
Do not overtighten.
 16. Place a new O-ring in the groove around the cathode post.
 17. Cover the holes at the base of the cathode stem with several drops of electrolyte solution.
 18. Insert a small blunt probe, like a toothpick with the end cut off, through the pressure equalizing port.

See [Figure 1-1](#).

CAUTION

Equipment damage

A sharp probe may puncture the bladder and destroy the sensor.

Do not use a sharp probe.

-
19. Gently press the probe against the bladder several times to force liquid through the holes at the base of the cathode stem. Keep

pressing the bladder until no air bubbles can be seen leaving the holes.

Be sure the holes remain covered with electrolyte solution.

20. Place a drop of electrolyte solution on the cathode; then place the membrane assembly over the cathode.
21. Screw the membrane retainer in place.

The sensor may require several hours operating at the polarizing voltage to equilibrate after the electrolyte solution has been replenished.

6 Accessories

Part #	Description
33523-00	Electrolyte fill plug
9550094	O-ring, Viton 2-014
33521-00	Membrane retainer
23501-08	Free chlorine membrane assembly: includes one membrane assembly and one O-ring
23502-08	Free chlorine membrane kit: includes three membrane assemblies and three O-rings
9210356	#4 free chlorine sensor fill solution, 4 oz (120 mL)



GLOBAL HEADQUARTERS

Emerson Automation Solutions
6021 Innovation Blvd
Shakopee, MN 55379, USA

 +1 800 999 9307 or +1 952 906 8888

 F +1 952 949 7001

 liquid.csc@emerson.com

NORTH AMERICA

Emerson Automation Solutions
8200 Market Blvd
Chanhassen, MN 55317

 Toll Free +1 800 999 9307

 F +1 952 949 7001

 liquid.csc@emerson.com

EUROPE

Emerson Automation Solutions
Neuhofstrasse 19a P.O. Box 1046
CH-6340 Baar
Switzerland

 T + 41 (0) 41 768 6111

 F + 41 (0) 41 768 6300

 liquid.csc@emerson.com

MIDDLE EAST AND AFRICA

Emerson Automation Solutions
Emerson FZE
Jebel Ali Free Zone
Dubai, United Arab Emirates, P.O. Box
17033

 T +971 4 811 8100

 F +971 4 886 5465

 liquid.csc@emerson.com

 [Linkedin.com/company/Emerson-Automation-Solutions](https://www.linkedin.com/company/Emerson-Automation-Solutions)

 twitter.com/rosemount_news

 [Facebook.com/Rosemount](https://www.facebook.com/Rosemount)

 [youtube.com/RosemountMeasurement](https://www.youtube.com/RosemountMeasurement)

©2019 Emerson. All rights reserved.

The Emerson logo is a trademark and service mark of Emerson Electric Co. Rosemount is a mark of one of the Emerson family of companies. All other marks are the property of their respective owners.