

Rosemount™ 802 Wireless Multi Discrete I/O Transmitter



Safety messages

⚠ WARNING

Failure to follow safe installation and servicing guidelines could result in death or serious injury.

Ensure only qualified personnel perform installation or service.

Ground the electronics enclosure in accordance with local and national installation codes.

Explosions could result in death or serious injury.

Installation of device in an explosive environment must be in accordance with appropriate local, national, and international standards, codes, and practices.

Verify that the operating environment of the device is consistent with the appropriate hazardous locations certifications.

Before connecting a handheld communicator in an explosive atmosphere, ensure that the instruments are installed in accordance with intrinsically safe or non-incendive field wiring practices.

Electrostatic hazard that can result in death or serious injury

Warning - Explosion hazard. Do not open when energized.

Avertissement - Risque d'explosion. Ne pas ouvrir lorsque sous tension.

Warning - The surface resistivity of the antenna is greater than one gigaohm. To avoid electrostatic charge build-up, it must not be rubbed or cleaned with solvents or a dry cloth.

Conduit/cable entries

The conduit/cable entries in the transmitter housing use a ½–14 NPT thread form.

When installing in a hazardous location, use only appropriately listed or Ex certified plugs, glands, or adapters in cable/conduit entries.

Ensure external conduit/cable fittings are Type 4X rated or better (C22.2 No 94.2/UL 50E requirement).

Physical access

Unauthorized personnel may potentially cause significant damage to and/or misconfiguration of end users' equipment. This could be intentional or unintentional and needs to be protected against.

Physical security is an important part of any security program and fundamental in protecting your system. Restrict physical access by unauthorized personnel to protect end users' assets. This is true for all systems used within the facility.

NOTICE

Shipping considerations for wireless products (lithium batteries: Black Power Module, model number 701PBKKF):

Emerson shipped the transmitter to you without the Black Power Module installed. Remove the Black Power Module prior to shipping the transmitter. Each Black Power Module contains two C size primary lithium batteries. Primary lithium batteries are regulated in transportation by the U.S. Department of Transportation and are also covered by the International Air Transport Association (IATA), International Civil Aviation Organization (ICAO), and European Ground Transportation of Dangerous Goods (ADR). It is the shipper's responsibility to ensure compliance with these or any other local requirements. Before shipping, consult current regulations and requirements.

1 Parts needed

1.1 In the box

- Quick Start Guide
- Rosemount 802 Transmitter
- Five conduit plugs
- Optional - 802 mounting bracket (if ordered via option code B6)
- Optional - cable glands (if ordered via option codes G1-5 or R1-5)

1.2 Ordered separately

- Emerson 701P SmartPower™ Module - Black (Model Number: 701PBKKF)

1.3 802 Transmitter

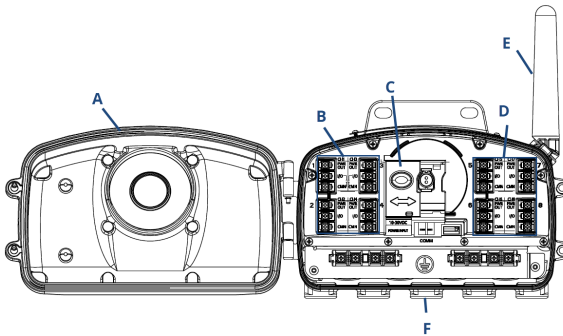

- A. Cover
- B. Discrete terminals 1-4
- C. Power input slider
- D. Discrete terminals 5-8
- E. Antenna
- F. Conduit entries (five)

2 Device preparation

2.1 Power up

Note

There are two methods to power up the transmitter: either with the 701P SmartPower™ Module - Black or a 10-30 Vdc external power supply.

Prerequisites

Verify the Wireless Gateway is installed and functioning properly before powering any wireless devices.

Procedure

1. Using a Phillips head screwdriver, back out screws so the cover opens.

Figure 2-1: Cover screws



A. Cover screws

Note

The default power position is with the power module terminals exposed.

Figure 2-2: Power module configuration

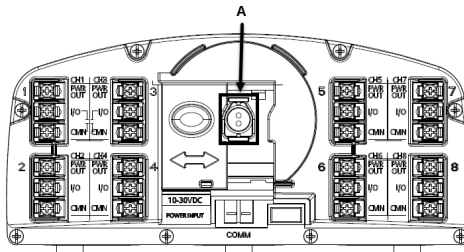

A. Plastic plug

2. Remove the plastic plug from the receptacle.

- 3. Power the device in one of two ways:
 - Install the 701P SmartPower Module into the 802 Transmitter to power the device.
 - Move the mechanical slider to expose the external power supply terminals and power the transmitter with a 10-30 Vdc power source.

Input voltage 10-30 Vdc
Input current 805 mA
(maximum)

Power supply must be isolated from AC mains and provide transient free DC input power to the transmitter.

Figure 2-3: External power supply configuration

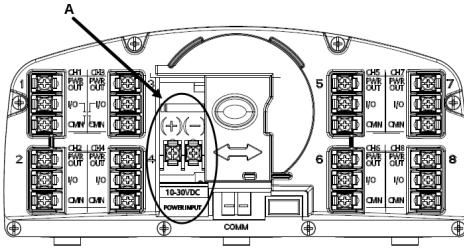

A. Power supply

2.2 Antenna position

Position the antenna vertically, approximately 3 ft. (1 m) away from any large structure, building, or conductive surface to allow for clear communication to other devices.

Figure 2-4: Antenna position

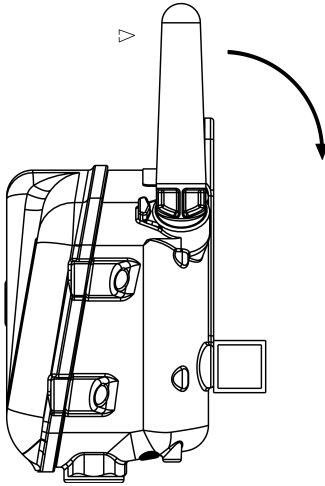

2.3 Plug conduits

Procedure

Plug the unused conduit entries with supplied conduit plugs with approved sealant.

3 Provisioning & commissioning

3.1 Provision transmitter

Prerequisites

You must power up the transmitter before the communication device can interface with it. For HART® wireless transmitter communication via a communication device, an 802 wireless device descriptor (DD) is required.

Procedure

To obtain the latest DD, go to [Software & Drivers](#).

Figure 3-1: Connection diagram

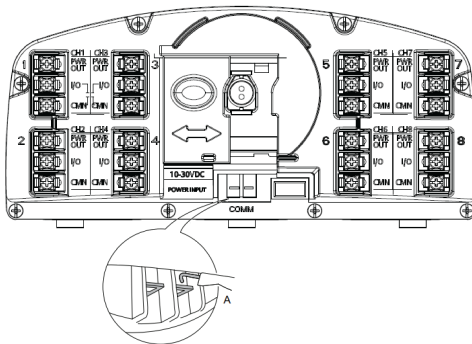

A. Communication terminals

Note

The Emerson 475 Field Communicator will not work as a communication device for the 802 Transmitter.

3.2 Commission transmitter to Gateway

If you ordered the transmitter with a factory-configured network ID and join key, it should join the network with no user input.

If you're unsure if you ordered the device with the factory-configured option, you can manually enter the network ID and join key to match the Gateway.

Procedure

1. To obtain the network ID and join key, go to **Network** → **Network Settings** in the Gateway user interface.

Figure 3-2: Network Settings page in Gateway user interface

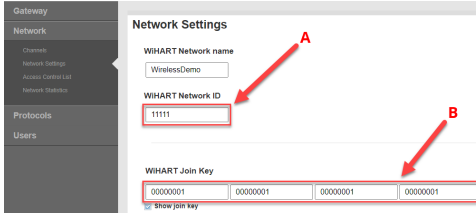

- A. Network ID
- B. Join Key

2. Use communication device or HART® modem to configure the transmitter by entering the network ID and join key, as shown in Figure 3-1.

Note

It may take several minutes for the device to join the network.

Figure 3-3: Gateway Explorer page

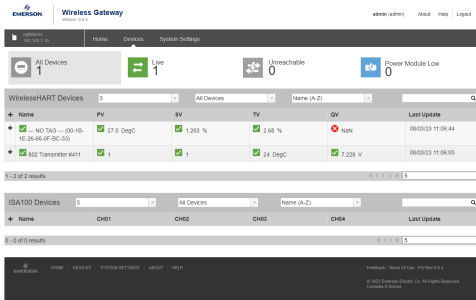

4 Terminal wiring for input and output circuits

The transmitter has three screw terminals for each channel.

These terminals are labeled as follows:

PWR OUT	Constant power out
I/O	Switched input or output channel
CMN	Common

Note

All eight channels have a third **PWR OUT** terminal that outputs continuous voltage which can be up to 2 Vdc less than the supplied external power to the transmitter. (For example, 28 Vdc into the transmitter, **PWR OUT** terminal outputs 26 Vdc)

4.1 Discrete inputs

Note

Optionally, you can use the device to invert any input to change the discrete logic state. This is useful, for instance, if a normally open switch is used to replace a normally closed switch.

Figure 4-1: Discrete input circuit

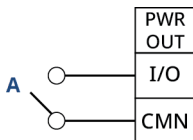

A. Dry contact only

4.2 Discrete output switch functionality

The host control system drives the discrete output of the 802 Transmitter through the Wireless Gateway and out to the transmitter.

The time required for wireless communication from the Gateway to the transmitter is dependent on many factors, including the size and topology of the network and the total amount of downstream traffic on the wireless network. For a network that is constructed to Emerson's best practices, typical delays in communication of a discrete output from the Gateway to the transmitter are 15 seconds

or less. Remember that this delay is only part of the latency that will be observed in a control loop.

Figure 4-2: Discrete output circuit

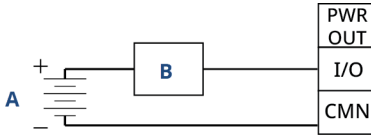

- A. External power supply
- B. Load

4.3 Alternative discrete output functionality

All eight channels have a third `PWR OUT` terminal that outputs continuous voltage, which can be up to 2 Vdc less than the supplied external power to the transmitter. (For example, if the external power supplies 28 Vdc to the transmitter, the `PWR OUT` terminal will output 26 Vdc.)

Figure 4-3 shows the alternative wiring configuration.

Figure 4-3: Alternative discrete output circuit wiring circuit

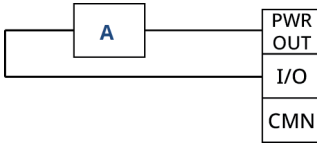

- A. Load

4.4 Special considerations for multi-output circuits

Important

If more than one channel is connected to output circuits, it is very important that the `CMN` terminal of each circuit be at the same voltage. Employing a common ground for all output circuits is one way to ensure that all circuits have `CMN` terminals at the same voltage.

If two output circuits are connected to a single transmitter with a single power supply, both input/output (`I/O`) and common (`CMN`) terminals must be connected to each output circuit. The negative power supply wires must be at the same voltage and connected to both `CMN` terminals.

Figure 4-4: Multiple output circuits with one power supply

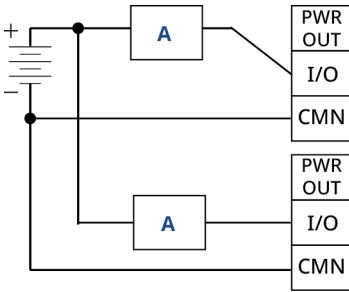

A. Load

4.5 Switching greater currents or voltages

Note

Maximum switching capacity is 28 Vdc and 100 mA per channel. If you need to switch a greater voltage or current, use an interposing relay circuit.

Figure 4-5 shows an example of a circuit to switch higher currents or voltages.

Figure 4-5: Wiring an interposing relay to switch greater currents or voltages

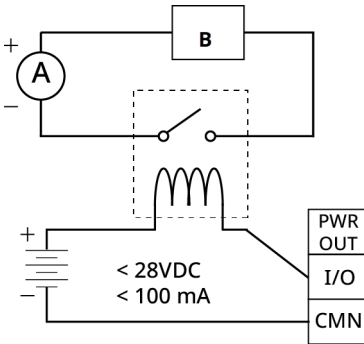

A. Power supply

B. Load

5 Mount transmitter remotely

Emerson has designed the 802 Transmitter to be installed only in the remote mount configuration, where the sensor is mounted separately from the housing and then connected to the transmitter via conduit.

Procedure

1. Install the transmitter according to standard installation practices.
Make sure to use thread sealant on all connections.
2. To reduce sensor wiring length, mount the transmitter centrally to all of the measurements. When installing the transmitter, make sure the conduit entries are facing downward. If using the mounting bracket (option code B6), mount the transmitter to a 2-in. (51 mm) pipe.

Figure 5-1: 802 mounting bracket (bottom view)

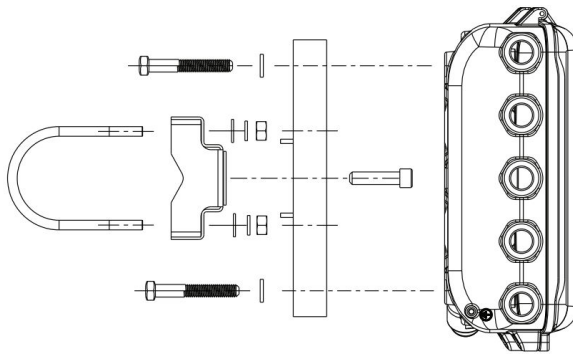

Postrequisites

For additional remote mounting information, see [Emerson.com](https://www.emerson.com).

6 Grounding the transmitter

The transmitter operates best with the housing grounded

Floating systems, however, can cause extra noise that may affect the accuracy of the transmitter. If the signal appears noisy or erratic, grounding at a single point may solve the problem. Ground the transmitter through the process connection using the internal or external grounding terminal.

7 Product certifications

Revision 2.5

7.1 European Directive information

A copy of the EC Declaration of Conformity can be found at the end of the Quick Start Guide. The most recent revision of the EC Declaration of Conformity can be found at [Emerson.com/Rosemount](https://www.emerson.com/Rosemount).

7.2 Telecommunication compliance

All wireless devices require certification to ensure they adhere to regulations regarding the use of the radio frequency (RF) spectrum. Nearly every country requires this type of product certification.

Emerson is working with governmental agencies around the world to supply fully compliant products and remove the risk of violating country directives or laws governing wireless device usage.

7.3 Federal Communications Commission (FCC) and Innovation, Science, and Economic Development Canada (ISED)

This device complies with Part 15 of the FCC Rules. Operation is subject to the following conditions: This device may not cause harmful interference; this device must accept any interference received, including interference that may cause undesired operation. This device must be installed to ensure a minimum antenna separation distance of 7.9 in. (20 cm) from all persons.

This device contains license-exempt transmitter(s)/receiver(s) that comply with Innovation, Science, and Economic Development Canada's license exempt RSS(s). Operation is subject to the following two conditions:

1. This device may not cause interference.
2. This device must accept any interference, including interference that may cause undesired operation of the device.

Changes or modification to the equipment not expressly approved by Emerson could void the user's authority to operate the equipment.

L'émetteur/récepteur exempt de licence contenu dans le présent appareil est conforme aux CNR d'Innovation, Sciences et Développement économique Canada applicables aux appareils radio exempts de licence. L'exploitation est autorisée aux deux conditions suivantes :

1. L'appareil ne doit pas produire de brouillage;
2. L'appareil doit accepter tout brouillage radioélectrique subi, même si le brouillage est susceptible d'en compromettre le fonctionnement.

Les changements ou les modifications apportés à l'équipement qui n'est pas expressément approuvé par Emerson pourraient annuler l'autorité de l'utilisateur à utiliser cet équipement.

7.4 Ordinary location certification

As standard, the transmitter has been examined and tested to determine that the design meets the basic electrical, mechanical, and fire protection requirements by a Nationally Recognized Test Laboratory (NRTL), as accredited by the Federal Occupational Safety and Health Administration (OSHA).

7.5 Installing in North America

The US National Electrical Code® (NEC) and the Canadian Electrical Code (CEC) permit the use of Division marked equipment in Zones and Zone marked equipment in Divisions.

The markings must be suitable for the area classification, gas, and temperature class. This information is clearly defined in the respective codes.

7.6 USA

7.6.1 N5 USA Division 2, Non-Incendive

Certificate	FM24US0017X
Markings	NI Class I, Division 2, Groups A, B, C, D T4 (-50 °C ≤ Ta ≤ +70 °C)

Field wiring shall be rated for +172 °F (+78 °C).

Enclosure Type 4X/IP66

Specific Conditions for Safe Use (X):

Only the Emerson SmartPower™ 701PBKKF shall be used for replacement.

7.7 Canada

7.7.1 N6 Canada Division 2, Non-Incendive

Certificate	FM24CA0008X
Markings	NI Class I, Division 2, Groups A, B, C, D

T4 (-50 °C ≤ Ta ≤ +70 °C)

Field wiring shall be rated for +172 °F (+78°C).

Enclosure Type 4X/IP66

Specific Conditions for Safe Use (X):

Only the Emerson SmartPower™ 701PBKFF shall be used for replacement.

7.8 Declaration of Conformity



EU DECLARATION OF CONFORMITY



This declaration of conformity is issued under the sole responsibility of

Rosemount Inc.
6021 Innovation Blvd
Shakopee, MN 55379
USA

that the following products,

Rosemount™ 802 Wireless Multi Discrete I/O Transmitter

comply with the provisions of the European Union Directives, including the latest amendments, valid at the time this declaration was signed.

 (signature & date of issue)	<i>February 26, 2024</i>	Mark Lee (name)	Vice President, Quality (function)	Boulder, CO, USA (place of issue)
--	--------------------------	----------------------	---	--------------------------------------

Authorized Representative in Europe:
Emerson S.R.L., company No. J12/88/2006
Emerson 4 street, Parcul Industrial
Tetarom II, Cluj-Napoca 400638, Romania

Regulatory Compliance Shared Services Department
Email: europaeproductcompliance@emerson.com Phone: +40 374 132 035

EMC Directive (2014/30/EU)
Harmonized Standards:
EN 61326-1:2021

RED Directive (2014/53/EU)
Harmonized Standards:
EN 300 328 V2.2.2
EN 301 489-1 V2.2.3
EN 301 489-17 V3.2.4
EN 62311: 2020



Quick Start Guide
MS-00825-0100-4082, Rev. AA
March 2024

For more information: [Emerson.com/global](https://www.emerson.com/global)

©2024 Emerson. All rights reserved.

Emerson Terms and Conditions of Sale are available upon request. The Emerson logo is a trademark and service mark of Emerson Electric Co. Rosemount is a mark of one of the Emerson family of companies. All other marks are the property of their respective owners.

ROSEMOUNT™

