

Rosemount™ 2140 and 2140:SIS Level Detectors

Vibrating Fork



- Integrates into existing wired HART® loops of automated systems without extra wiring costs
- Switch between HART 5 and HART 7
- Industry first “Media Learn” functionality
- Exclusive liquid-to-sediment detection capability
- Increased safety, SIL2-certified to IEC 61508 as required by IEC 61511 and SIL3 capable
- Unique remote proof testing
- Smart Diagnostics Suite

Introduction

Measurement principle

The Rosemount 2140 and 2140:SIS are the world's first wired HART® level detector using Emerson's vibrating fork technology.

Using the principle of a tuning fork, a piezo-electric crystal oscillates the forks at their natural frequency. Changes to the oscillation frequency are continuously monitored by electronics as it varies depending on the liquid medium in which the forks are immersed. The denser the liquid, the lower the oscillation frequency.

Whenever a liquid medium in a vessel (tank) or pipe drains down past the forks, it causes a distinct frequency change. This change is detected by the electronics and a dry condition is indicated.

Whenever a liquid medium in a vessel (tank) or pipe rises and contacts the forks, again a distinct frequency change is detected. This time, the electronics will indicate a wet condition.

The wet and dry conditions can be transmitted digitally as a HART signal or as a discrete output using the analog output.

Key features and benefits

- Virtually unaffected by turbulence, foam, vibration, solids content, coating products, or liquid properties.
- Adjustable detection output delay prevents false detection in turbulent or splashing applications.
- 'Fast drip' fork design gives quicker response time when mounted horizontally, especially with viscous liquids.
- A Media Learn function to ensure reliable detection even if the media characteristics are unknown.
- Functionality is included for detecting sediment in a vessel.

Smart Diagnostics Suite

Frequency profiling

- Detects abnormal frequency deviations and responses from the fork sensor

Power advisory

- Detects abnormal deviations in the loop power through the device

Process alerts

- Set user-configurable alerts on HART variables

Contents

Introduction.....	2
Ordering information.....	4
Specifications.....	12
Product certifications.....	17
Dimensional drawings.....	18

Access information when you need it with asset tags

Newly shipped devices include a unique QR code asset tag that enables you to access serialized information directly from the device. With this capability, you can:

- Access device drawings, diagrams, technical documentation, and troubleshooting information in your MyEmerson account
- Improve mean time to repair and maintain efficiency
- Ensure confidence that you have located the correct device
- Eliminate the time-consuming process of locating and transcribing nameplates to view asset information

Application examples

Applications for the Rosemount 2140 version of the level detector include overflow prevention ([Figure 1](#)), high and low level alarms, pump protection, and separation processes ([Figure 2](#)).

The Rosemount 2140:SIS version is certified to IEC 61508 for safety-critical applications. Applications also include overflow prevention, high and low level alarms, and pump protection.

Figure 1: Overflow Prevention

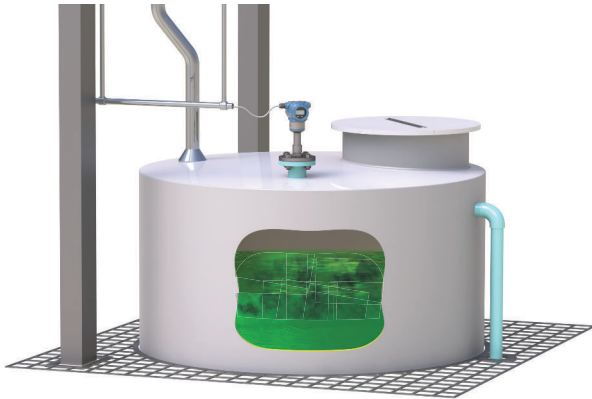
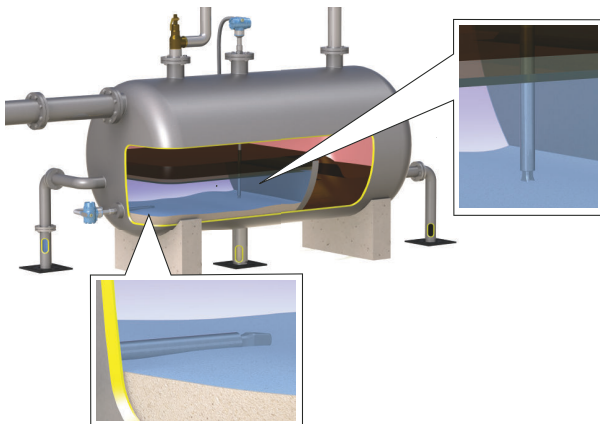

Figure 2: High and Low level Alarms and Pump Control



Ordering information

Online product configurator

Many products are configurable online using our product configurator.

Select the **Configure** button or visit [Emerson.com/global](https://emerson.com/global) to start. With this tool's built-in logic and continuous validation, you can configure your products more quickly and accurately.

Specifications and options

The purchaser of the equipment must specify and select the product materials, options, or components.

Related information

[Specifications](#)

[Material selection](#)

Model codes

Model codes contain the details related to each product. Exact model codes will vary; an example of a typical model code is shown in [Figure 3](#).

Figure 3: Model Code Example

2140 A H A 1 M S 1 N N B A 0000 1 E1	Q4 M4 HR7
1	2

1. Required model components (choices available on most)
2. Additional options (variety of features and functions that may be added to products)

Optimizing lead time

The starred offerings (★) represent the most common options and should be selected for the fastest delivery times. The non-starred offerings are subject to additional delivery lead time.

Rosemount 2140 and 2140:SIS Level Detectors ordering information



The Rosemount 2140 is a wired HART® vibrating fork level detector for applications including overflow prevention, high and low level alarms, and pump protection. Providing reliable level detection of all liquids as well as sediments, the Rosemount 2140 offers greater ease-of-use and flexibility with smart diagnostics that continuously monitor electronic and mechanical device health, and a fully integrated remote proof-testing capability, helping to increase safety and efficiency of both plant and workers. The Rosemount 2140:SIS is certified to IEC 61508 (SIL 2) for safety-critical applications.

CONFIGURE >

VIEW PRODUCT >

Required model components

Model

Code	Description	
2140	Vibrating Fork Liquid Level Detector	★

Profile

Code	Description	
A	Standard monitoring and control application	★
F	Functional Safety / SIS applications	★

Related information

[Profile features](#)

Output

Code	Description	
H	mA output with HART communication	★

Related information

[HART revision configuration](#)

Housing material

Code	Description	
A	Aluminum alloy ASTM B85 A360.0	★
S	Stainless steel, 316C	★

Conduit entry / cable threads

Code	Description	
1	½-in. ANPT	★
2	M20	★

Operating temperature

Code	Description	
M	Mid-Range: -40 °F (-40 °C) ... 356 °F (180 °C)	★
E	High: -94 °F (-70 °C) ... 500 °F (260 °C)	★

Materials of construction: process connection/fork

Code	Description	
S	316/316L Stainless Steel (1.4401/1.4404)	★
F ⁽¹⁾⁽²⁾	ECTFE copolymer, coated 316/316L stainless steel (1.4401/1.4404)	★
H	Alloy C (UNS N10002), Alloy C-276 (UNS N10276)	

(1) ECTFE copolymer coating is only available for a flanged Rosemount 2140. Flanges are dual certified 316 and 316L Stainless Steel (1.4401 and 1.4404).

(2) The operating temperature code M must be selected (mid-range) and the process temperature must be below 302 °F (150 °C).

Process connection size

Code	Description	Available process connections	
9	¾-in. / 19 mm	Thread	★
1	1-in. / 25 mm (DN25) / 25A	Thread, flange	★
2	2-in. / 50 mm (DN50) / 50A	Thread, flange, Tri Clamp	★
5	1½-in. / 40 mm (DN40) / 40A	Flange, Tri Clamp	★
3	3-in. / 80 mm (DN80) / 80A	Flange	★
4	4-in. / 100 mm (DN100) / 100A	Flange	★
7	2½-in. / 65 mm (DN65) / 65A	Flange	★
M	For use with Mobrey™ flange	Flange	★

Process connection rating

Code	Description	
AA	ASME B16.5 Class 150 flange	★
AB	ASME B16.5 Class 300 flange	★
AC	ASME B16.5 Class 600 flange	★
DA	EN1092-1 PN 10/16 flange	★
DB	EN1092-1 PN 25/40 flange	★
DC	EN1092-1 PN 63 flange	★
DD	EN1092-1 PN 100 flange	★
JA	JIS B2220, 10K flange	★
JB	JIS B2220, 20K flange	★
MA	Mobrey A flange	★
MG	Mobrey G flange	★
NN	For use with non-flange process connection type	★

Process connection type

Code	Description	
R	Raised Face (RF) flange	★
M	Mobrey flange	★
B	BSPT (R) thread	★
G	BSPP (G) thread	★
N	NPT thread	★
P	BSPP (G) O-ring	★
C	Tri Clamp	★

Fork length

Code	Description	Available process connections	
A	Standard length 1.7 in. (44 mm)	All except flanged options	★
H	Standard length flange 4.0 in. (102 mm)	Flange	★
E	Extended, customer specified length in tenths of inches	All except 1-in. BSPP O-ring (1P)	★
M	Extended, customer specified length in millimeters	All except 1-in. BSPP O-ring (1P)	★

Related information

[Customer specified fork length](#)

Specific extended fork length

Code	Description	
0000	Factory default length (only if fork length A or H is selected)	★
0060	6 inches extended length (only if fork length E is selected)	Best delivery (★) in North America.
0090	9 inches extended length (only if fork length E is selected)	Best delivery (★) in North America.
0120	12 inches extended length (only if fork length E is selected)	Best delivery (★) in North America.
0140	24 inches extended length (only if fork length E is selected)	Best delivery (★) in North America.
XXXX ⁽¹⁾	Specific customer specified length in tenths of inches or millimeters (XXX.X inches or XXXX mm)	★

(1) Examples: Code E1181 is 118.1 in. Code M3000 is 3000 mm.

Related information

[Customer specified fork length](#)

Surface finish

Code	Description	Available process connections	
1	Standard surface finish	All	★
2	Mechanically polished (Ra < 0.1 μm)	Tri Clamp	★

Product certifications

Code	Description	
NA	No hazardous locations certifications (safe area use only)	★
ND	ATEX Dust	★
E1 ⁽¹⁾	ATEX Flameproof	★
E8	ATEX Flameproof, Dust	★
I1 ⁽¹⁾	ATEX Intrinsic Safety, Dust	★
I8	ATEX Intrinsic Safety (ib)	★
K1	ATEX Intrinsic Safety, Flameproof, Dust	★
NK	IECEx Dust	★
E7	IECEx Flameproof and Dust	★
I7	IECEx Intrinsic Safety	★
G5 ⁽²⁾	USA Ordinary Location (unclassified, safe area)	★
E5 ⁽²⁾	USA Explosion-proof	★
I5	USA Intrinsically Safe and Nonincendive	★
K5	USA Intrinsically Safe, Explosion-proof	★
G6 ⁽³⁾	Canada Ordinary Location (unclassified, safe area)	★
E6 ⁽³⁾	Canada Explosion-proof	★
I6	Canada Intrinsic Safety and Nonincendive	★
KB	USA and Canada Explosion-proof, Intrinsically Safe, Nonincendive	★
KZ	USA and Canada Ordinary Location	★
E2	Brazil Flameproof	★
I2	Brazil Intrinsic Safety	★
E3	China Flameproof and Dust	★
I3	China Intrinsic Safety	★
EW	India Flameproof	★
IW	India Intrinsic Safety	★

(1) Includes an equivalent Indian CCOE approval.

(2) E5 includes G5 requirements. G5 is for use in unclassified, safe area locations only.

(3) E6 includes G6 requirements. G6 is for use in unclassified, safe area locations only.

Related information

[Product certifications](#)

Additional options

Calibration data certification

Code	Description	
Q4	Certificate of functional test	★

Material traceability certification

Only available for process-wetted parts.

Code	Description	
Q8	Material traceability certification per EN 10204 3.1	★

Material certification

Not available for code H (Alloy C/Alloy C-276) process-wetted parts.

Code	Description	
Q15	NACE® MR0175 / ISO 15156	★
Q25	NACE MR0103	★

Dye penetration test certificate

Code	Description	
Q73	Certificate of liquid penetrant inspection	★

Positive material identification certificate

Code	Description	
Q76	Positive material identification certificate of conformance	★

Terminal block

Code	Description	
T1	Transient protection terminal block	★

Display

Code	Description	
M4	LCD display with Local Operator Interface	★

Special procedures

This option is limited to units with extended lengths up to 59.1 in. (1500 mm). Option is not available for ECTFE coating.

Code	Description	
P1	Hydrostatic testing with certificate	★

Overfill prevention

Code	Description	
U1	WHG/DIBt overfill protection	★

Alarm levels

Code	Description	
C4	Analog output levels compliant with NAMUR recommendation NE43, high alarm	★
C5	Analog output levels compliant with NAMUR recommendation NE43, low alarm	★
C1	Custom alarm and saturation signal levels (requires Configuration Data Sheet)	★
C8	Low alarm (standard Rosemount alarm and saturation levels)	★

HART revision configuration

Code	Description	
HR5	HART 5	★
HR7	HART 7	★

Safety certification

Only the Rosemount 2140:SIS is SIL2-certified.

Code	Description	
QS	Prior-use certificate of FMEDA Data	★
QT	Safety certified to IEC61508	★

Extended product warranty

Code	Description	
WR3	3-year limited warranty	★
WR5	5-year limited warranty	★

Profile features

Table 1: Profile Selection Features

Feature	Rosemount 2140 (profile option code A)	Rosemount 2140:SIS (profile option code F)
Remote proof testing	Yes	Yes
Local proof testing (using test button)	Yes	Yes
Media learn	Yes	Yes
Frequency output	Yes	Yes
Sediment detection	Yes	No
Scaled variable	Yes	No
Smart Diagnostics Suite	Yes	Yes
HART 5 or HART 7	Yes	Yes

Spare parts and accessories

Seal

Part number	Description
02100-1000-0001	Seal for 1-in. BSPP (G1A) process connection. Material: Non-asbestos BS7531 grade X carbon fiber with rubber binder
02100-1040-0001	Seal for ¾-in. BSPP (G3/4A) process connection. Material: Non-asbestos BS7531 grade X carbon fiber with rubber binder

Adaptor boss

Part number	Description
02100-1010-0001	Adaptor boss, 1-in. BSPP to 1½-in. (38 mm) Tri Clamp Materials: 316 stainless steel fitting, FPM/FKM O-ring

Tri Clamp kit

Part number	Description
02100-1020-0001	2-in. (51 mm) Tri Clamp kit (vessel fitting, clamp ring and seal) Materials: 316 stainless steel, NBR Nitrile

Quick release kit

The quick release kit is a set of accessories requiring a Rosemount 2140 with the 2-in. Tri Clamp option and an existing 2-in. NPT process connection on the vessel.

Part number	Description
02100-1060-0001	Quick release kit (contains 2-in. Tri Clamp, seal, and quick release device for 2-in. NPT process connection)

Related information

[Release Kit Quick Start Guide](#)

Terminal block

Part number	Description
02140-7000-0003	Standard terminal block assembly (T0)
02140-7000-0004	Transient terminal block assembly (T1)

Specifications

General

Measuring technology

Vibrating fork

Applications

Point level detection in liquid process mediums, including coating liquids, aerated liquids, and slurries. Suitable for horizontal and vertical installation.

Functional safety

The Rosemount 2140:SIS is IEC 61508 certified to:

- Type B low-demand device
- SIL 2 @ HFT = 0
- SIL 3 @ HFT = 1

Related information

[Functional Safety Certificate](#)

[Rosemount 2140:SIS Safety Manual](#)

Performance specifications

Hysteresis (water)

0.1 in. (2.5 mm)

Switching point (water)

0.5 in. (13 mm) from fork tip if mounted vertically.

0.5 in. (13 mm) from the fork edge if mounted horizontally.

The switching point varies with different liquid densities.

The level detector allows pre-selection of a liquid density range, and has a built-in learning function to make it even easier.

Detection output delay

Optional output delay, programmable from 0 to 3600 seconds, to prevent false detection caused by splashing on the forks. Default delay is 1 second.

Liquid density ranges

There are four field-selectable density options for the level detector to use even more accurate switching points. The default pre-selection is "Standard" and is suitable for most liquids.

- Low (400 to 600 kg/m³)
- Medium (500 to 900 kg/m³)
- Standard (800 to 1300 kg/m³)
- High (1200 to 3000 kg/m³)

Liquid viscosity range

Up to 10000 cP (centiPoise) when operating in the Normal mode.

Up to 1000 cP (centiPoise) when operating in Enhanced mode.

Electrical specifications

Power supply

10.5 to 42.4 Vdc (with no load)

Output

Digital process variable is superimposed on 4–20 mA signal, available to any host that conforms to HART protocol.

Table 2: Current Output Availability

Current Output operating types ⁽¹⁾	Rosemount 2140 (profile option code A)	Rosemount 2140:SIS (profile option code F)
8/16 mA HART switched output	Yes	Yes
4/20 mA HART switched output	Yes	Yes
Custom mA HART switched output	Yes	Yes
4–20 mA HART	Yes	No
LEVELTESTER switched output	Yes	Yes

(1) *Software selectable.*

HART revision

- Revision 5
- Revision 7

The HART revision can be switched in field.

Related information

[HART revision configuration](#)

Terminal connection (wire diameter)

Minimum 24 AWG, maximum 14 AWG (0.2 to 2.5 mm²)

Environmental specifications

Maximum operating pressures

Figure 4: Operating Pressures

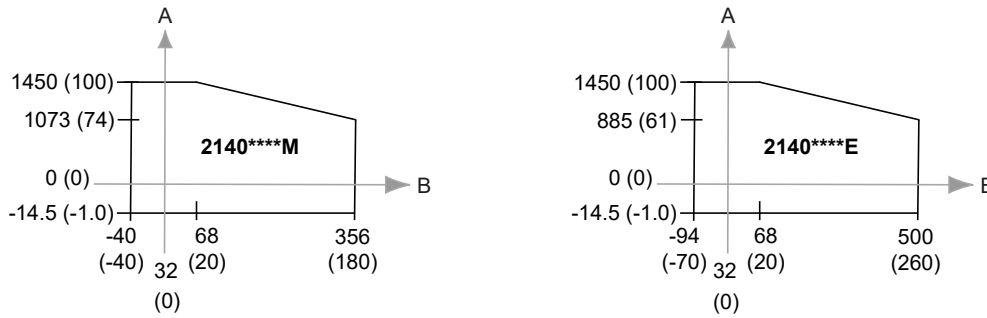

- A. Process pressure, psig (barg)
- B. Process temperature, °F (°C)

The final rating depends on the process-wetted connection.

Threaded connection

See [Figure 4](#).

Tri Clamp connection

435 psig (30 barg)

Flanged connection

The maximum operating pressure is the lower of the process pressure ([Figure 4](#)) and flange pressure rating (see [Table 3](#)).

Table 3: Maximum Flange Pressure Rating

Standard	Class/rating	Stainless steel flanges
ASME B16.5	Class 150	275 psig ⁽¹⁾
ASME B16.5	Class 300	720 psig ⁽¹⁾
ASME B16.5	Class 600	1440 psig ⁽¹⁾
EN1092-1	PN 10/16	16 barg ⁽²⁾
EN1092-1	PN 25/40	40 barg ⁽²⁾
EN1092-1	PN 63	63 barg ⁽²⁾
EN1092-1	PN 100	100 barg ⁽²⁾
JIS B2220	10K	14 barg ⁽³⁾
JIS B2220	20K	34 barg ⁽³⁾
Mobrey A flange	Not applicable	33 bar
Mobrey G flange	Not applicable	21 bar

(1) At 100 °F (38 °C), the pressure rating decreases with an increasing process temperature.

(2) At 122 °F (50 °C), the pressure rating decreases with an increasing process temperature.

(3) At 248 °F (120 °C), the rating decreases with an increasing process temperature.

Maximum and minimum operating temperatures

See [Figure 5](#) for the maximum and minimum operating temperatures.

Figure 5: Operating Temperatures

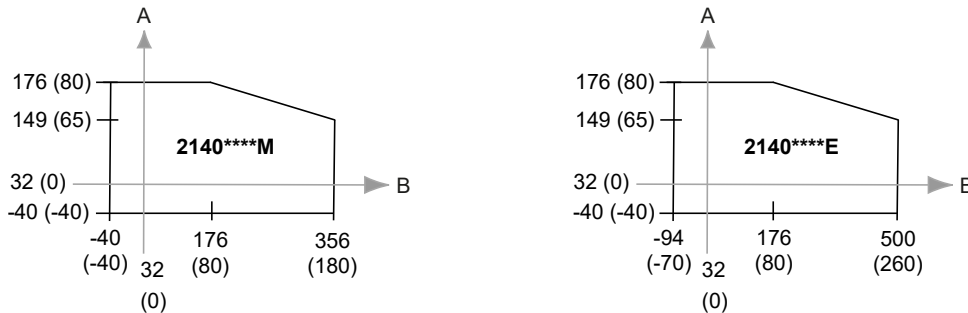

- A. Ambient Temperature, °F (°C)
- B. Process Temperature, °F (°C)

See the Rosemount 2140 [Product Certifications](#) document for operating temperature limits required by approvals.

Physical specifications

Material selection

Emerson provides a variety of Rosemount products with various product options and configurations, including materials of construction that can be expected to perform well in a wide range of applications. The Rosemount product information presented is intended as a guide for the purchaser to make an appropriate selection for the application. It is the purchaser's sole responsibility to make a careful analysis of all process parameters (such as all chemical components, temperature, pressure, flow rate, abrasives, contaminants, etc.), when specifying product, materials, options, and components for the particular application. Emerson is not in a position to evaluate or guarantee the compatibility of the process fluid or other process parameters with the product, options, configuration, or materials of construction selected.

Electronics housing

Housing material

Aluminum alloy ASTM B85 A360.0 or stainless steel (316C)

Rotation

Rotatable housing to allow more convenient cable position.

Local display

Optional two-line LCD display with Local Operator Interface (LOI). There are two internal and two external configuration buttons. Includes extended cover with glass window.

Local proof-test button

The level detector comes with a single external button for local proof testing. This single button is replaced by two configuration buttons when the LCD display with LOI option is selected.

Note

Remote proof-testing is available using a HART command.

Conduit plugs/cable glands

The Rosemount 2140 ships with dust caps installed in the conduit entries. One blanking plug is supplied in a plastic bag, ready to be installed. No cables or cable glands are supplied.

Ingress protection

IP66/67 to EN60529, NEMA® 4X (when supplied blanking plug and suitably rated cable glands are used).

Process wetted connections

Connections

Threaded, Tri Clamp, and flanged process connection options.

Materials

- 316/316L stainless steel (1.4401/1.4404 dual-certified)
Mechanically-polished option to better than 0.1 µm for Tri Clamp connections.
- Alloy C (UNS N10002) and Alloy C-276 (UNS N10276)
Available for flanged, and selected threaded process connections (¾-in. and 1-in. BSPT (R), and ¾-in. and 1-in. NPT).
- ECTFE co-polymer coated 316/316L Stainless Steel (1.4401/1.4404 dual certified)
Available only for flanged process connections, but excludes 1-in./DN25/25A flanges.
- Gasket material for ¾-in. and 1-in. BSPP (G) is non-asbestos BS7531 Grade X carbon fiber with rubber binder.
Gaskets are not supplied with flanged process connections.

Customer specified fork length

Table 4: Extended Fork Lengths

Process connection	Minimum	Maximum ⁽¹⁾
¾-in. threaded	3.8 in. (95 mm)	157.5 in. (4000 mm)
1-in. threaded	3.7 in. (94 mm)	157.5 in. (4000 mm)
2-in. threaded	3.7 in. (94 mm)	157.5 in. (4000 mm)
Flanged	3.5 in. (89 mm)	157.5 in. (4000 mm)
Tri Clamp	4.1 in. (105 mm)	157.5 in. (4000 mm)

(1) The maximum extended length is 157.5 in. (4000 mm), except for ECTFE co-polymer coating and polished process connection options which have a maximum length of 59.1 in. (1500 mm) and 39.4 in. (1000 mm) respectively.

Related information

[Dimensional drawings](#)

Product certifications

See the Rosemount 2140 [Product Certifications](#) document for detailed information on the existing approvals and certifications.

European directive information

A copy of the EU Declaration of Conformity can be found at the end of the Rosemount 2140 [Product Certifications](#) document. The most recent revision of the EU Declaration of Conformity can be found at [Emerson.com/Rosemount](https://emerson.com/rosemount).

Ordinary location certification

As standard, the device has been examined and tested to determine that the design meets the basic electrical, mechanical, and fire protection requirements by a nationally recognized test laboratory (NRTL) as accredited by the Federal Occupational Safety and Health Administration (OSHA).

Installing equipment in North America

The US National Electrical Code® (NEC) and the Canadian Electrical Code (CEC) permit the use of Division marked equipment in Zones and Zone marked equipment in Divisions. The markings must be suitable for the area classification, gas, and temperature class. This information is clearly defined in the respective codes.

Dimensional drawings

Refer to the Type 1 Drawings on the Rosemount 2140 [web page on Emerson.com](#) (**Documents & Drawings** → **Drawings & Schematics**) for dimensions of the O-ring seal (BSPP) versions.

Figure 6: Housing

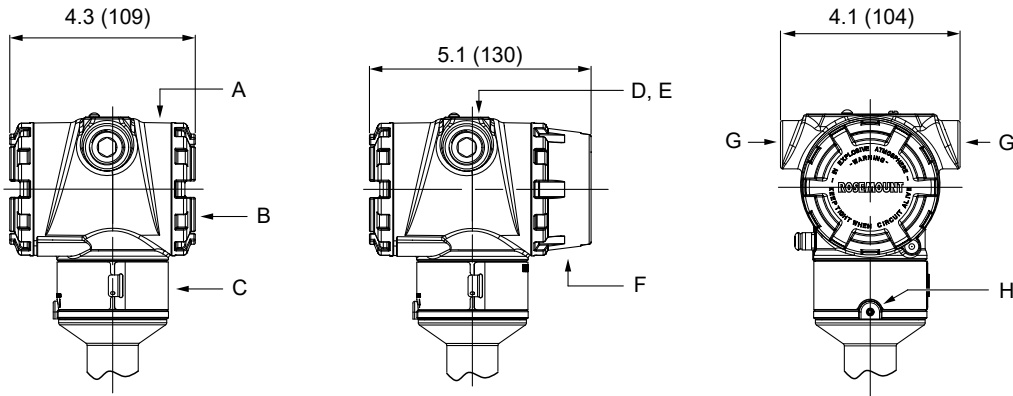

- A. Aluminum or stainless steel housing
- B. No LCD display
- C. Certification plate
- D. Cover plate (with logo, product name, and conduit entry size)
- E. External button(s) under movable plate
- F. LCD display option
- G. Conduit/cable entry M20 x 1.5 or ½-in. ANPT
- H. Housing rotation set screw. Do not unscrew all the way. Rotating the housing, without this screw in place, can damage the internal wiring

Dimensions are in inches (millimeters).

Figure 7: 3/4- and 1-in. Threaded Process Connection (Mid Temperature Range)

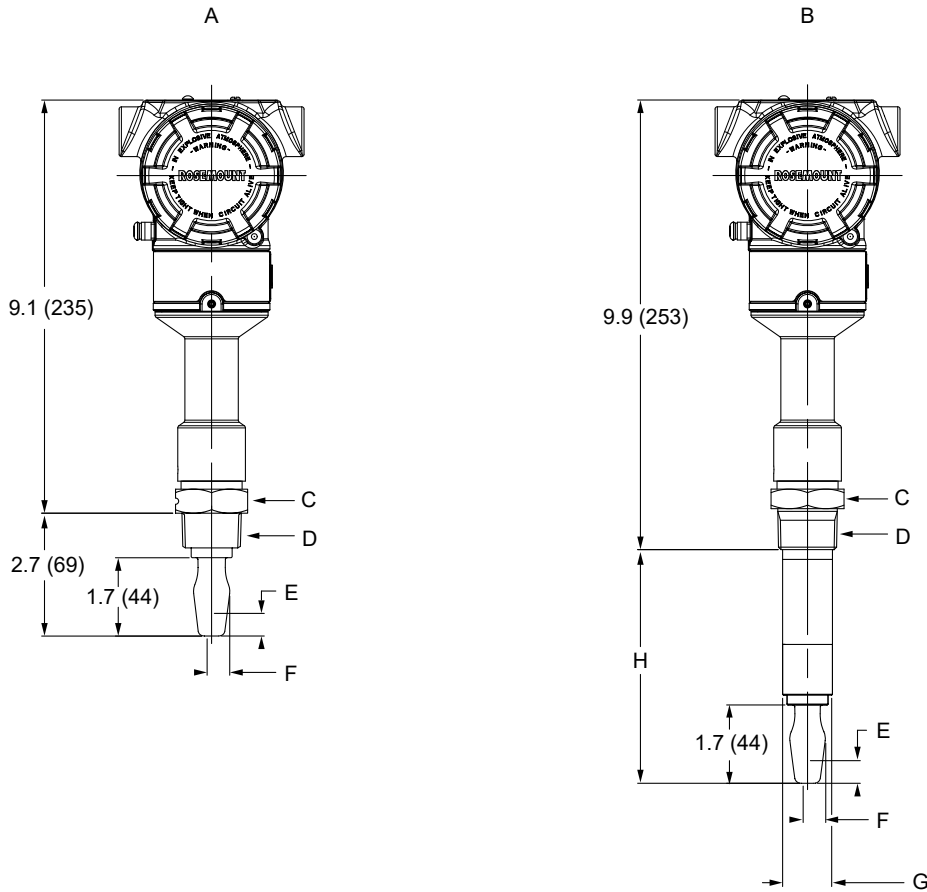

- A. Standard length fork
- B. Extended length fork
- C. 1.6 (40) A/F hexagon
- D. 3/4- or 1-in. thread
- E. 0.5 (13) switching point when mounted vertically
- F. 0.5 (13) switching point when mounted horizontally
- G. Ø1.14 (29) for 1-in. thread; Ø0.9 (23) for 3/4-in. thread
- H. Customer specified fork length (see [Table 4](#))

Dimensions are in inches (millimeters).

Figure 8: 3/4- and 1-in. Threaded Process Connection (High Temperature Range)

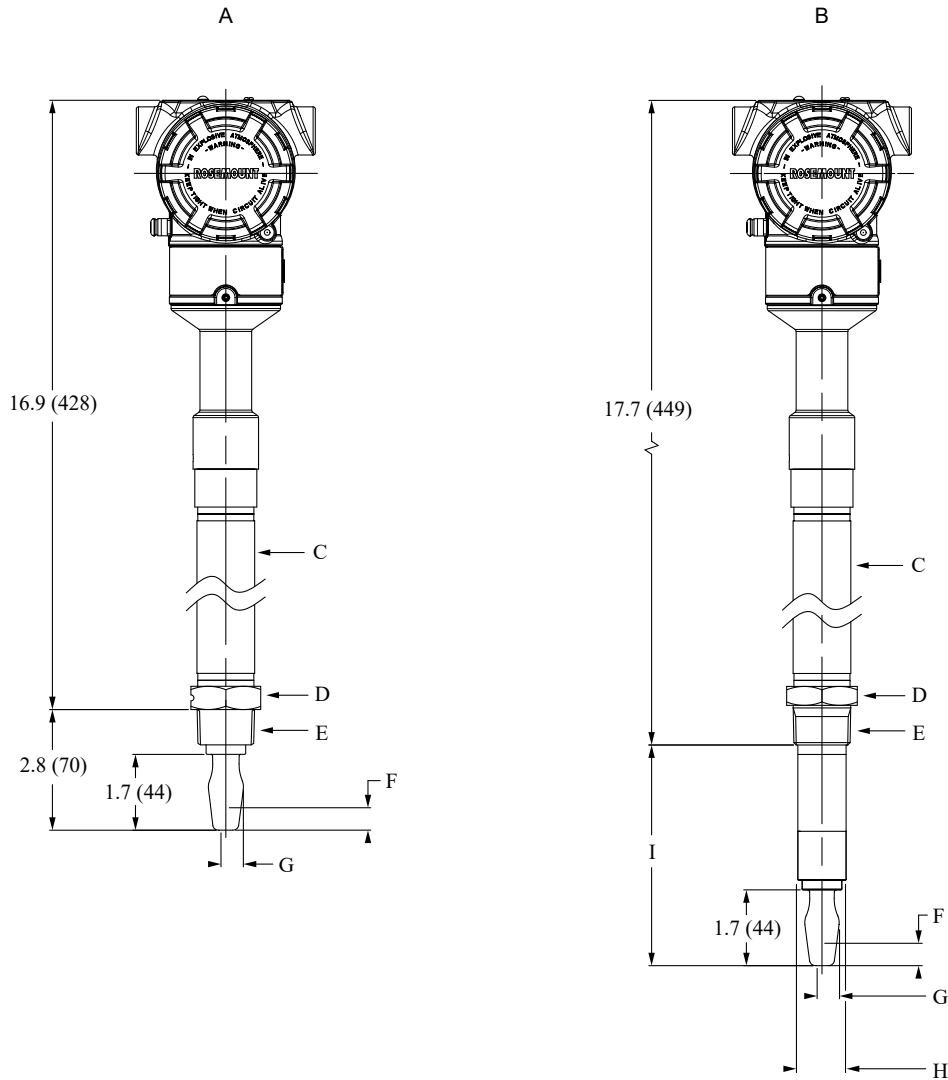

- A. Standard length fork
- B. Extended length fork
- C. Thermal tube
- D. 1.6 (40) A/F hexagon
- E. 3/4- or 1-in. thread
- F. 0.5 (13) switching point when mounted vertically
- G. 0.5 (13) switching point when mounted horizontally
- H. Ø1.14 (29) for 1-in. thread; Ø0.9 (23) for 3/4-in. thread
- I. Customer specified fork length (see Table 4)

Dimensions are in inches (millimeters).

Figure 9: 2-in. Threaded Process Connection (Mid Temperature Range)

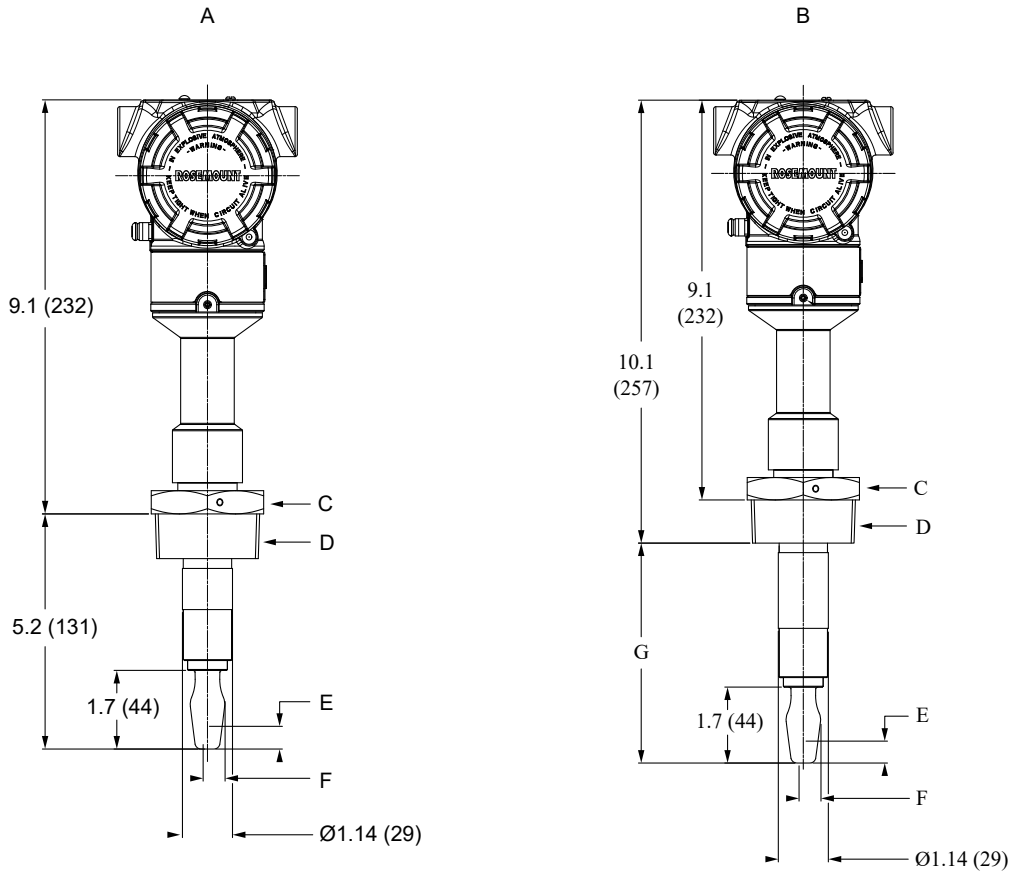

- A. Standard length fork
- B. Extended length fork
- C. 2.6 (65) A/F hexagon
- D. 2-in. thread
- E. 0.5 (13) switching point when mounted vertically
- F. 0.5 (13) switching point when mounted horizontally
- G. Customer specified fork length (see [Table 4](#))

Dimensions are in inches (millimeters).

Figure 10: Flanged Process Connection (Mid Temperature Range)

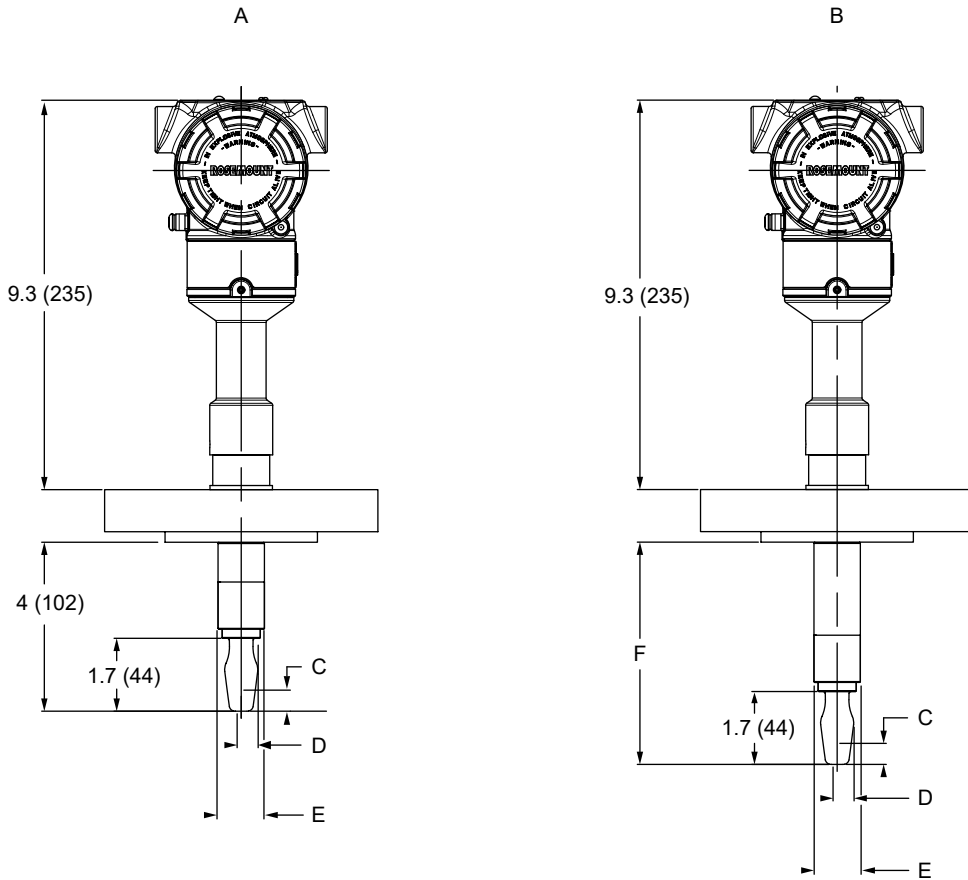

- A. Standard length fork
- B. Extended length fork
- C. 0.5 (13) switching point when mounted vertically
- D. 0.5 (13) switching point when mounted horizontally
- E. Ø0.9 (23) for up to 1-in. flange; Ø0.95 (24) for up to 1-in. coated flange; Ø1.14(29) for 1½-in. or larger flange
- F. Customer specified fork length (see [Table 4](#))

Dimensions are in inches (millimeters).

Figure 11: Flanged Process Connection (High Temperature Range)

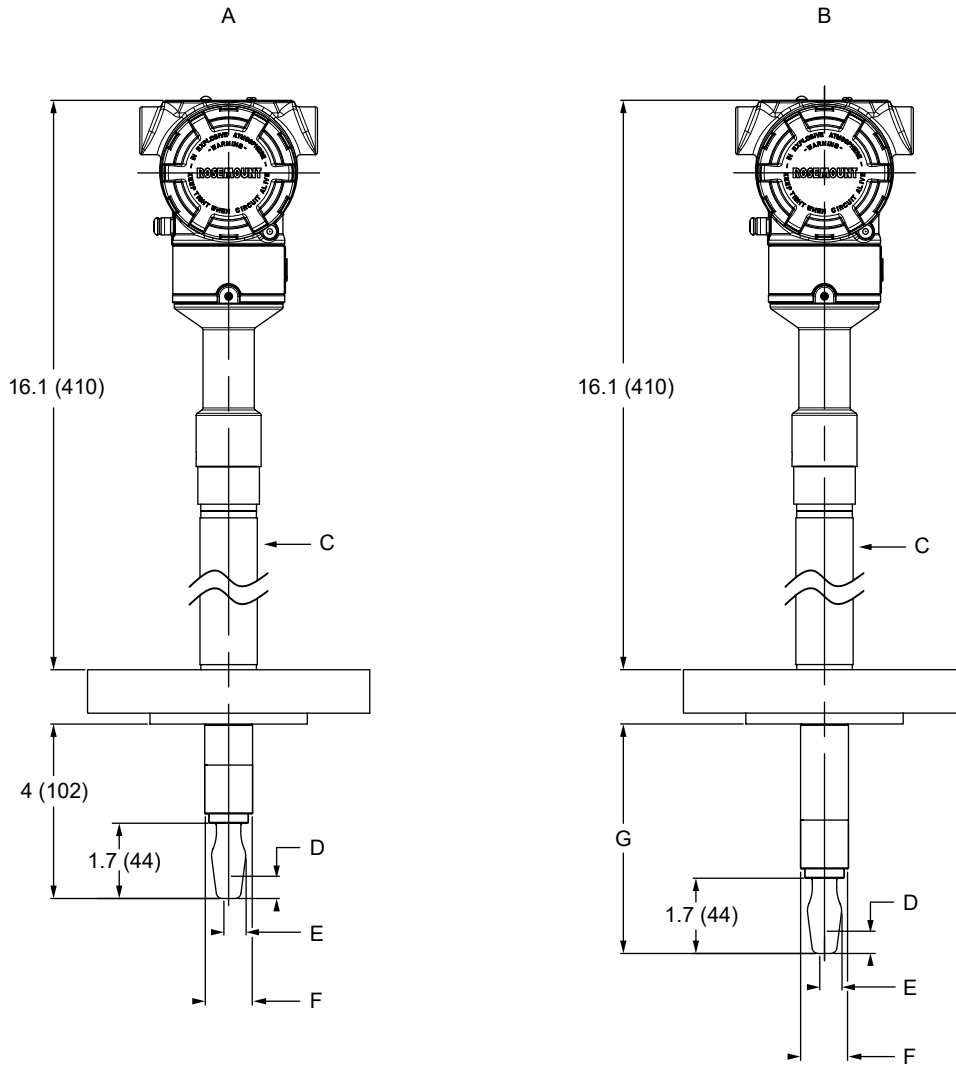

- A. Standard length fork
- B. Extended length fork
- C. Thermal tube
- D. 0.5 (13) switching point when mounted vertically
- E. 0.5 (13) switching point when mounted horizontally
- F. $\varnothing 0.9$ (23) for up to 1-in. flange; $\varnothing 1.14$ (29) for 1½-in. or larger flange
- G. Customer specified fork length (see [Table 4](#))

Dimensions are in inches (millimeters).

Figure 12: Tri Clamp Process Connection (Mid Temperature Range)

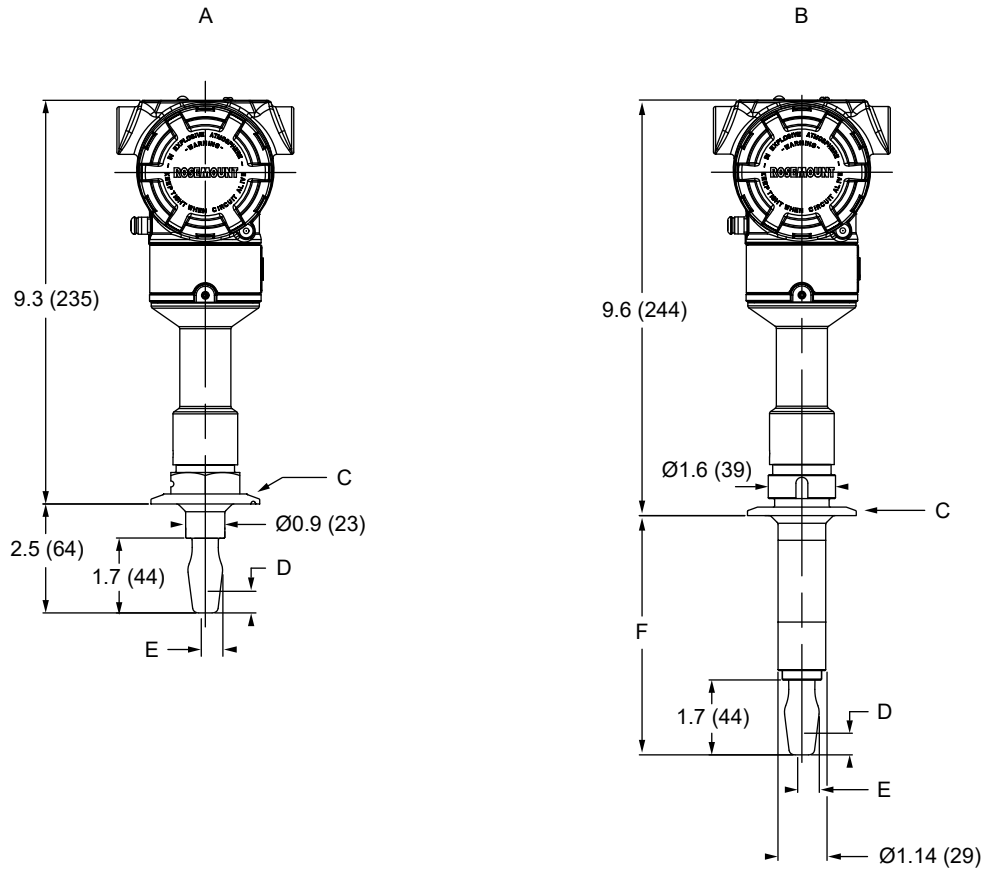

- A. Standard length fork
- B. Extended length fork
- C. 1½- or 2-in. Tri Clamp
- D. 0.5 (13) switching point when mounted vertically
- E. 0.5 (13) switching point when mounted horizontally
- F. Customer specified fork length (see [Table 4](#))

Dimensions are in inches (millimeters).

Figure 13: Tri Clamp Process Connection (High Temperature Range)

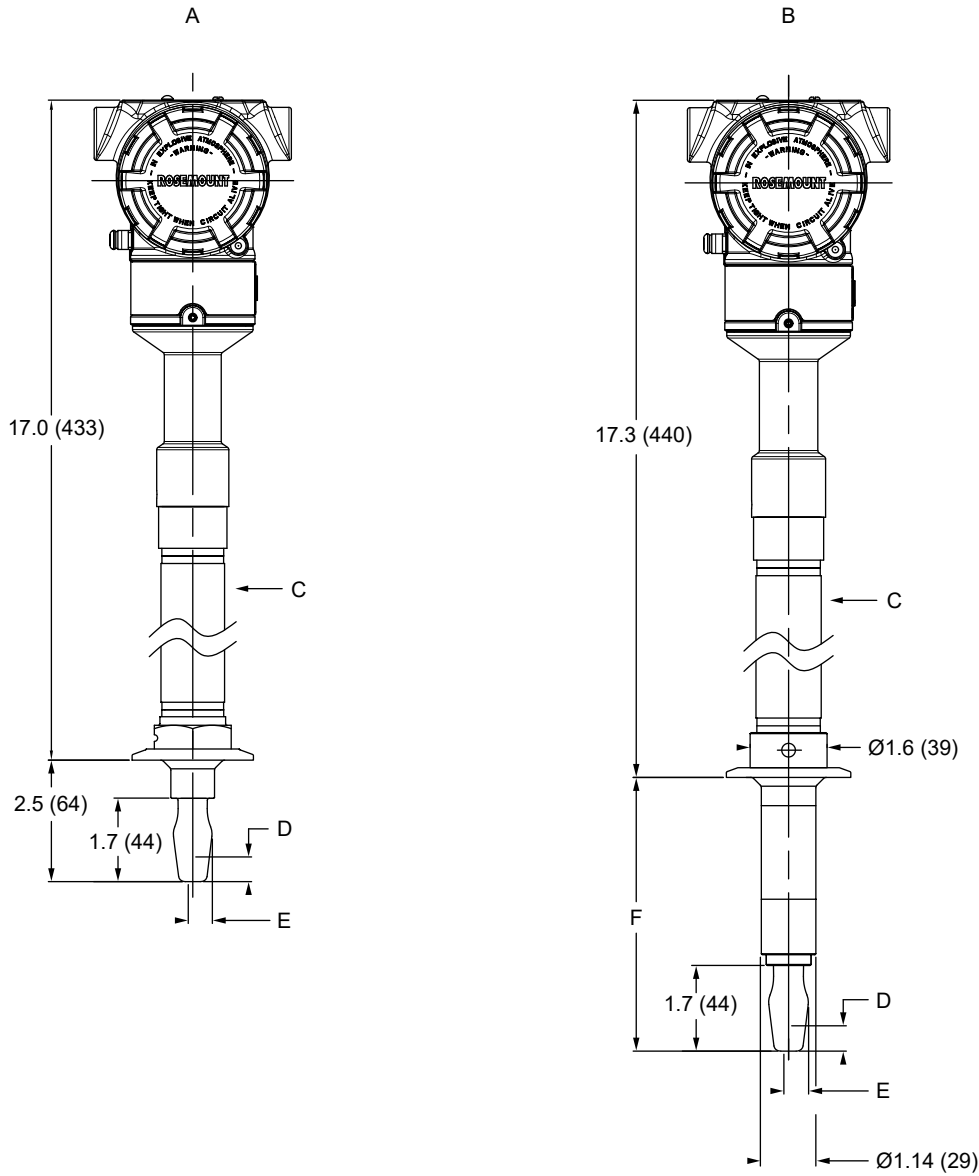

- A. Standard length fork
- B. Extended length fork
- C. Thermal tube
- D. 0.5 (13) switching point when mounted vertically
- E. 0.5 (13) switching point when mounted horizontally
- F. Customer specified fork length (see Table 4)

Dimensions are in inches (millimeters).

For more information: [Emerson.com/global](https://emerson.com/global)

©2024 Emerson. All rights reserved.

Emerson Terms and Conditions of Sale are available upon request. The Emerson logo is a trademark and service mark of Emerson Electric Co. Rosemount is a mark of one of the Emerson family of companies. All other marks are the property of their respective owners.

ROSEMOUNT™

