

# Smart Distribution Grid

Energy Harvesting Systems for Natural Gas Distribution

Natural gas distribution companies have been historically slow to adopt new technologies, especially so-called “smart” technologies, in their networks. Their counterparts in electric utilities, process plants, and even gas transmission have widely adopted connected components and solutions to give them quick access to data for decision making, improve system safety and provide them with the functionality to manage operations effectively. Recently, the natural gas distribution segment has begun to catch up by adopting these types of technologies to achieve similar results. Solution providers in the industry have developed customized systems for customers that can drive substantial value for gas utility companies.

For instance, frequent on-site interventions are still necessary to prevent failures and upgrade set points to accommodate seasonal demand evolution and to keep the supply/demand ratio balanced. With Emerson’s **Smart Solutions**, natural gas operators can minimize field trips and solve their challenges in terms of improved safety, reliability and efficiency of their networks.

What if you could:

- Have the ability to remotely control your pressure regulators
- Automatically adjust to the real needs of the end users
- Avoid trips on site, decreasing costs and improving safety

**Smart Solutions:** The use of integrated, scalable and connected solutions allows Distribution Companies to drive operational improvements, maintain optimal uptime, deploy resources more effectively, and enhance system safety for key stakeholders.

Put Emerson’s wealth of resources and expertise to work for you to resolve all your gas distribution needs and improve safety, reliability and efficiency of your natural gas grid.

**Contact our Emerson Sales Office for more information.**



## Micro Turbo Expander System

One of the main challenges that have slowed down the adoption of Smart technologies in the distribution network is that no electric power is usually available on site to feed monitoring and control devices. It is now possible to overcome this obstacle with the use of a micro turbo expander, a commercial product available on the market. A micro expander is a miniaturized and portable energy generator whose concept is inspired from turbomachinery. It is an 'energy harvesting' device, i.e. is able to locally generate electric energy off-grid from a pressurized fluid present on site, with no combustion and no CO<sub>2</sub> emissions.

It takes advantage of existing pressure drops and gas flow in the distribution grid to produce stabilized electrical power when supplied with pressurized gas. The fluid energy is captured by the micro expander and converted into electric energy, directly available on site.

The device composes of a micro turbo expander integrated into an electric micro generator, and of an external electronic power conditioning, battery charging and communication board, named Smart Battery Charger. The micro expander is ATEX certified hence able to be installed in hazardous as well as in safe areas, while the Smart Battery Charger must be installed in a safe area. The rated pressure of the micro expander is 10 bar, the inlet pressure is 0.5÷5 bar, with typical values being in the 1-2 bar range.

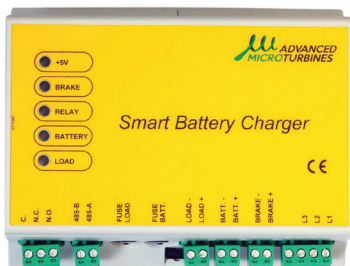

Smart battery charger

The key advantage of the micro expander is the continuous and reliable production of "free of charge" clean energy, fully independent of ambient conditions and external factors as is the case with solar or wind power. It produces energy 24/7, across all operating conditions with no risk of interruption of service.

With the micro expander, there are no upfront costs for connection to the electric grid. It enables real time monitoring of the skid, that would not be feasible with battery-fed systems (traditionally present in distribution skids) due to the large energy demand of real time wireless communication.

Thanks to its design and compact dimensions, the integration on existing skids is plug & play, allowing fast, simple and cost-effective retrofits. Currently two power levels are available: up to 30 W and up to 150 W. These two ranges allow micro expanders to feed a wide variety of 'Smart' solutions for the distribution network, driving greater operational efficiency as well as safety of gas pipelines and reduced energy consumption. As a result, the gas network becomes more reliable, energy efficient and better managed economically.



Micro expander

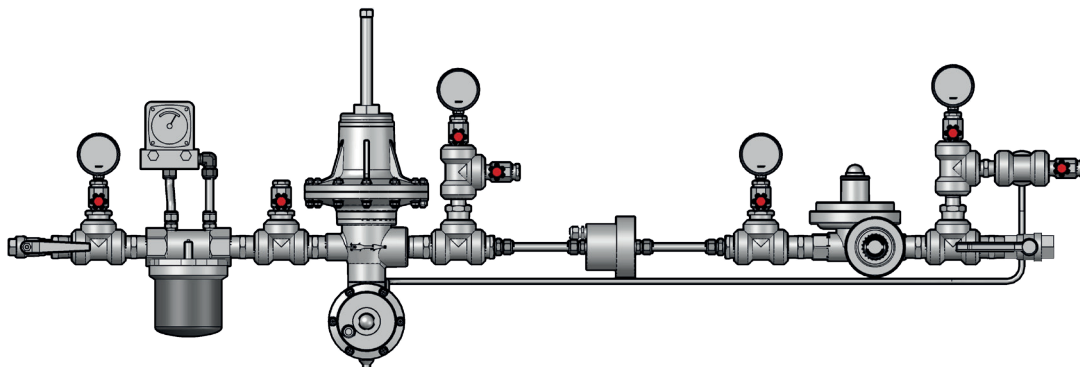

Micro expander pressure line

## RAF System

Another solution is the implementation of the RAF - NG PRMS Station Controller.

This is a scalable modular system used to provide full control and monitoring of a pressure reducing and metering station.

In a simplified version, it can serve a district station to modify the set point of pilot operated regulators, split the total flow rate into more lines and so on.

The available power levels of the micro expanders allow the adoption of these technologies in the distribution network.



RAF Control Panel

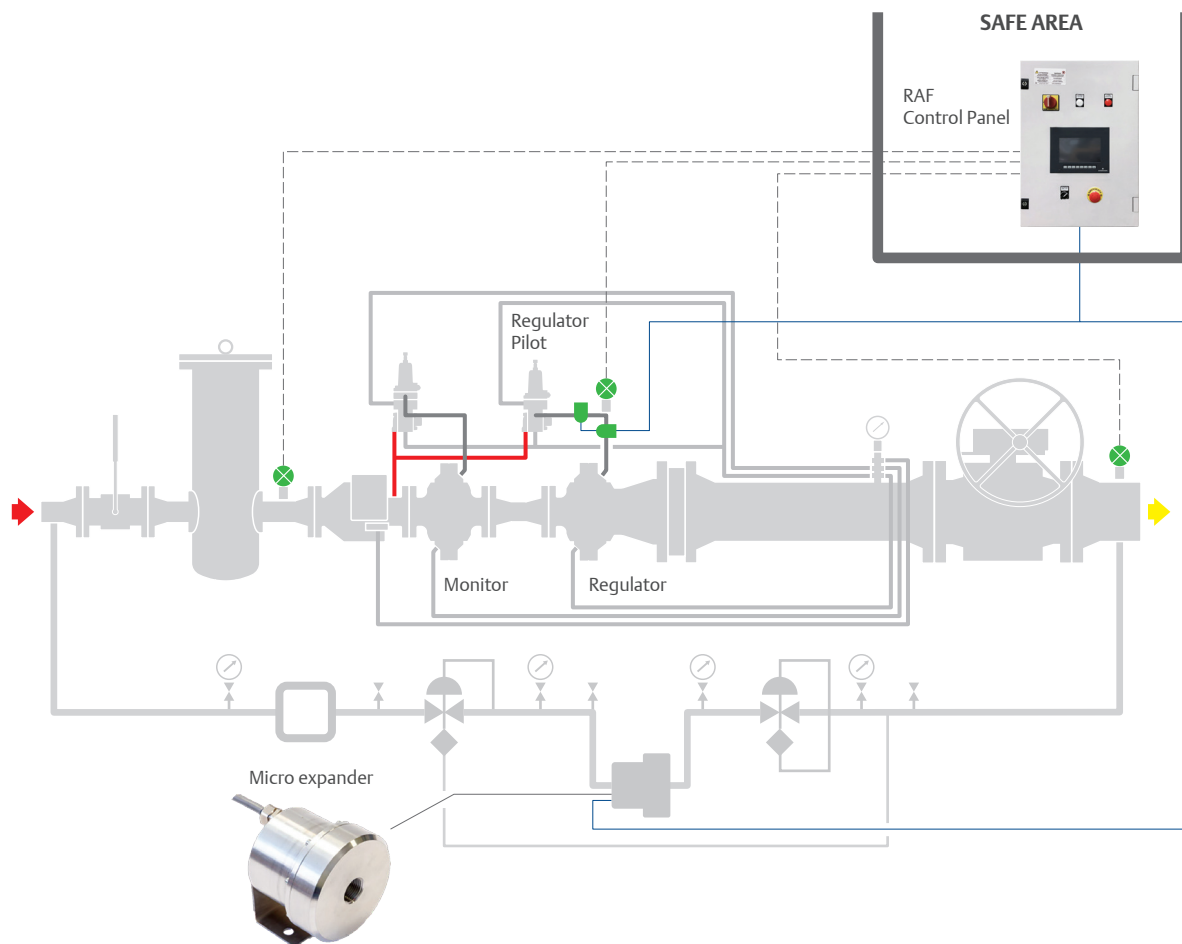

Typical connection scheme of a district station equipped with a RAF System fed by a micro expander



Subscribe to Emerson's latest product news,  
event invitations and quarterly newsletter:  
[emerson.com/subscribe](https://emerson.com/subscribe)

