

# Copeland Scroll™ compressor ZFKQ for Refrigeration Applications



Product catalogue

**COPELAND™**

  
**EMERSON™**

# ZFKQ Copeland Scroll™ Compressor for Refrigeration Applications



Emerson developed the ZFKQ range of Copeland Scroll™ compressors to provide the best performance in low temperatures. The series has a wide application envelope that can operate from -40°C to +7°C evaporating temperature. Its optimized design perfectly fits frozen food application requirements while its scroll compliance mechanism makes it highly tolerant of liquid slugging.

The range consists of:

- The ZF\*KQE models that operate with liquid injection in order to control discharge temperature and extend the operating envelope.
- The ZFI\*KQE models that are optimized for vapor injection with the use of a subcooler. This boosts the refrigeration system's cooling capacity and efficiency.



## Features and benefits

### High efficiency all year round

- The unique Copeland Compliant Scroll design patented by Emerson operates under continuous scroll flank contact, maintained by centrifugal force. This minimizes gas leakage while maximizing efficiency.
- With its capability for condensing operation down to 4°C on low temperature applications, Copeland Scroll technology provides the best seasonal efficiencies.
- Equipped with dynamic discharge valve that allows the discharge gas to reach desired pressure. This helps reduce efficiency loss by preventing gas re-compression.
- The vapor injection technology allows ZFI\*KQE compressors to perform higher efficiency than single-stage compressors at low temperature operation condition. Thus makes ZFI\*KQE the best in-class performance.

### Compactness

- The small footprint of Copeland Scroll compressors enables compact system designs.
- Weight and dimensions for refrigeration equipment is reduced with increased capacity per compressor weight.

## Table of contents

Features and benefits	04
Nomenclature	06
Bill of material	06
Operating envelopes	07
Product line-up	09
Performance data	10
Technical data	18
EVI CoreSense™	20
Dimensional drawings	25
Schematic diagram	38
Contact lists	44

## Robustness and reliability

- The Copeland Compliant Scroll design is tolerant to stresses caused by liquid slugging, flooded starts and debris commonly found in refrigeration systems.
- Easy to service and maintain due to their compact size and lightweight, simple design.
- Engineered for optimum performance with today's chlorine-free refrigerants.
  
- The Copeland Scroll compressor design has several inherent reliability advantages:
  - 70% fewer moving parts than reciprocating compressors
  - Axial & radial scroll compliance provides improved liquid handling capability
  - Hermetic design reduces leak potential
- Redesigned suction gas flow results in lower oil circulation and better motor cooling.
- EVI CoreSense™ Control kits provide advanced features to ensure optimum system operation.

## Compressor protection

- ZF\*KQE and ZFI\*KQE compressors are supplied with internal thermal protectors that prevent motor overheating in case of loss of phase or low refrigerant charge.
- The ZF\*KQE models that operate with liquid injection through DTC Valve in order to control the discharge temperature.
- The ZFI\*KQE models that can operate with Emerson EVI CoreSense™ control kits in order to control vapor injection superheat as well as a safe discharge temperature.

## Smooth operation

- All Copeland Scroll compressors are designed with a discharge check valve that isolates the high pressure discharge gas. This allows the compressor to start unloaded, resulting in low inrush currents.
- Smooth operations are made possible by the continuous compression process. This generates less vibration than reciprocating technology.

## Delivers unmatched energy efficiency: 5%–20% improvement

- Motor, scroll and bearing redesign minimize annual energy consumption.
- Precision machined scrolls provide the highest isentropic efficiency and wear-in for improved performance over time.
- New valving technology adjusts the scroll compression ratio based on operating condition, significantly improving low ambient performance.
- Using vapor injection improves system capacity by 50% and efficiency by 20% on average at the low temperature rating condition.



# Nomenclature

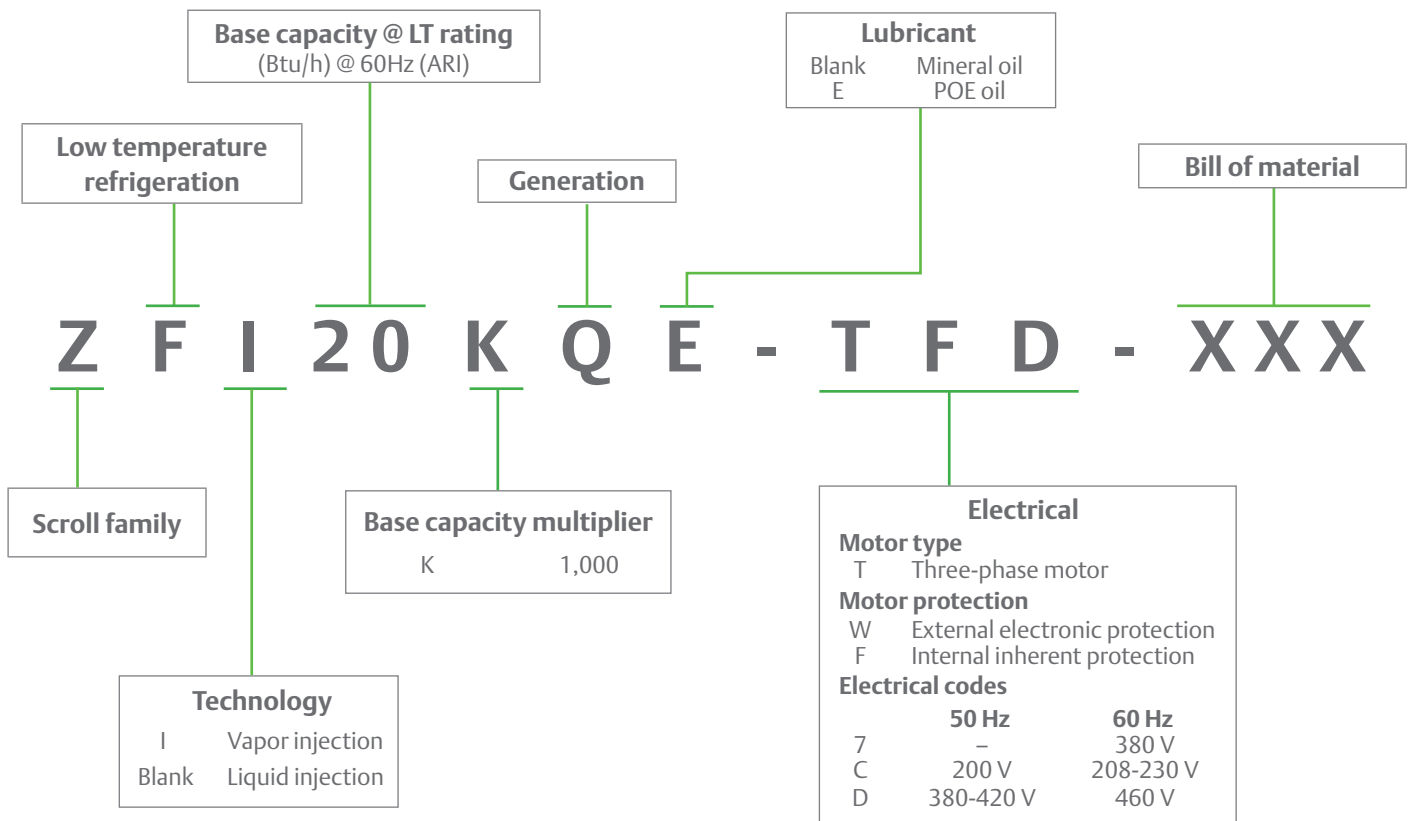

# Bill of material

Compressor model	Motor code	BOM number	Stub tube connection	Rotalock connection	Oil sight glass	Schrader valve
Liquid injection						
ZF06-11KQE	TFD, TFC	551		✓	✓	✓
ZF13-28KQE	TFD, TF7, TFC*	550	✓		✓	✓
		551		✓	✓	✓
ZF28KQE	TFC	580	✓		✓	✓
		591		✓	✓	✓
ZF34-49KQE	TFD, TF7, TFC	569	✓		✓	✓
		564		✓	✓	✓
Vapor injection						
ZFI20-39KQE	TFD, TF7, TFC*	550	✓		✓	✓
		552		✓	✓	✓
ZFI39KQE	TFC	580	✓		✓	✓
		592		✓	✓	✓
ZFI50-68KQE	TFD, TF7, TFC	569	✓		✓	✓
		564		✓	✓	✓

**Remarks:** See technical data sheet for the detailed connection size

ZF06-ZF49KQE only provide Rotalock connection to liquid injection fitting for the installation of DTC valve

\*Except ZF28KQE-TFC and ZFI39KQE-TFC

## Liquid injection

## Vapor injection

ZF06 - 18KQE

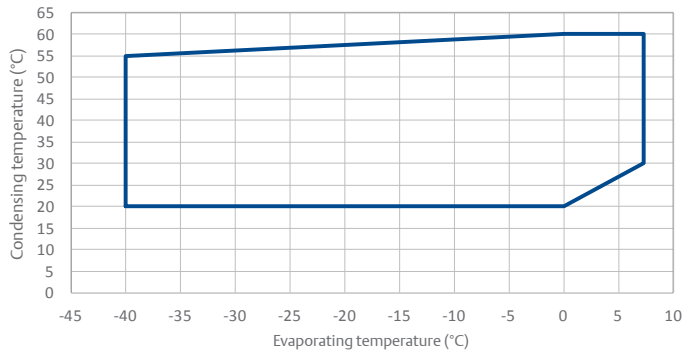

ZFI20-26KQE

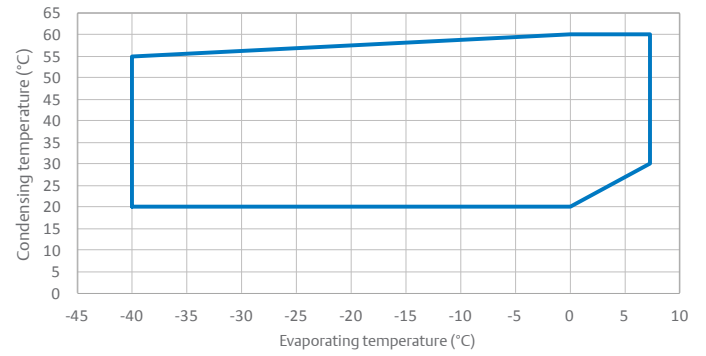

ZF25-41KQE

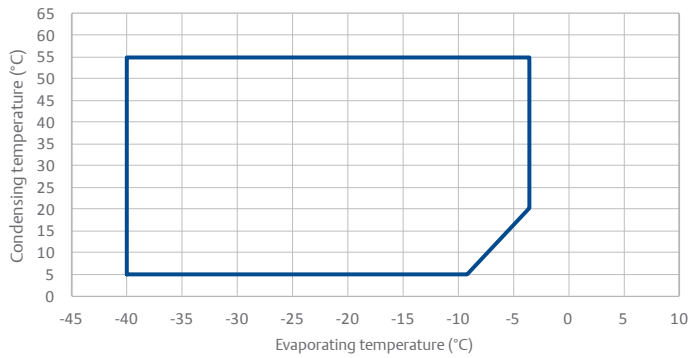

ZFI36-59KQE

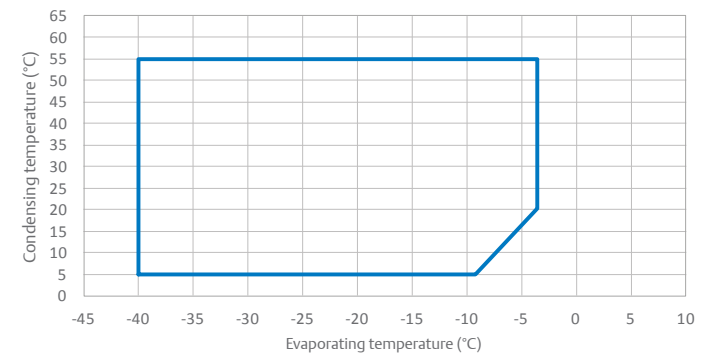

ZF49KQE

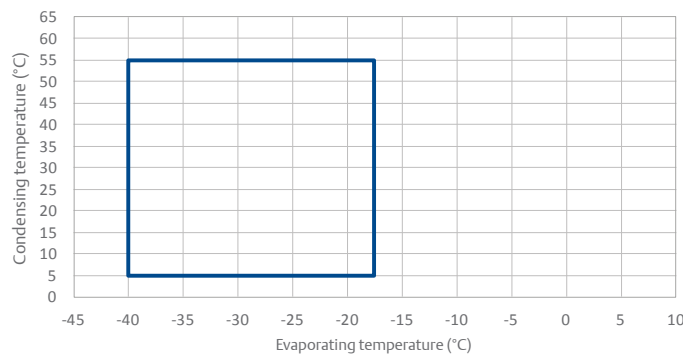

ZFI68KQE

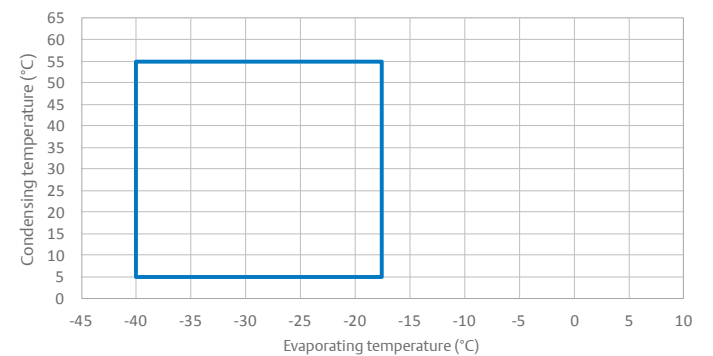

Note: — 20°C return gas + liquid injection

Note: — 20°C return gas + vapor injection

# Operating envelopes

# R404A/R507

## Liquid injection

## Vapor injection

ZF06 - 18KQE

ZFI20 - 26KQE

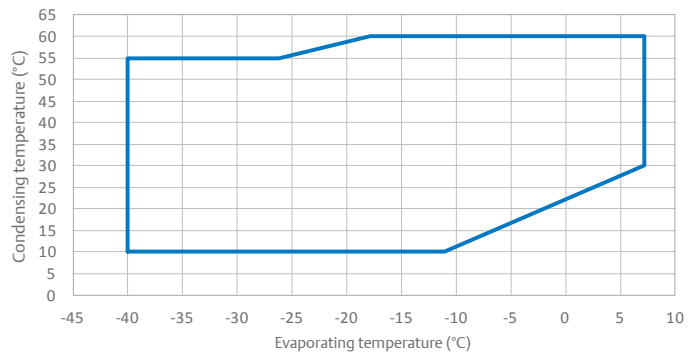
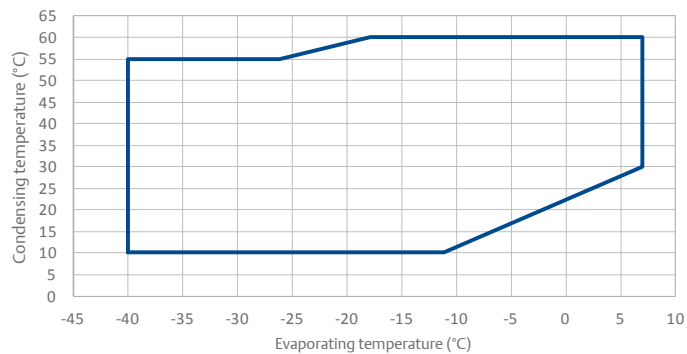

ZF25 - 41KQE

ZFI36 - 59KQE

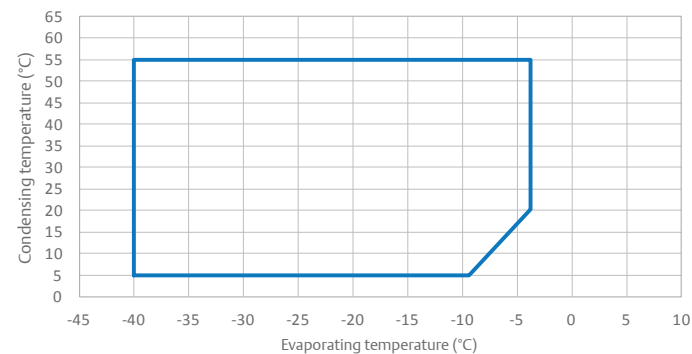
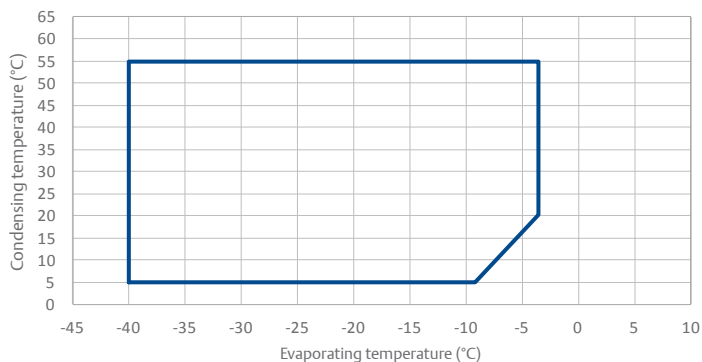

ZF49KQE

ZFI68KQE

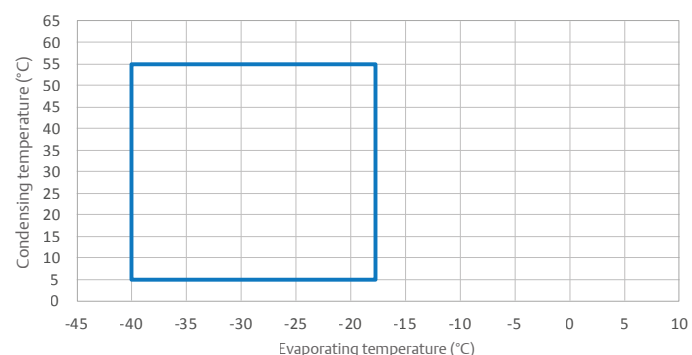
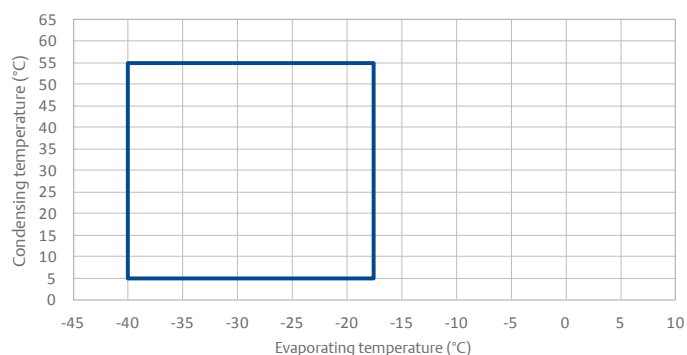

Note: — 20°C return gas + liquid injection

Note: — 20°C return gas + vapor injection

# Product line-up

## R404A - 50Hz

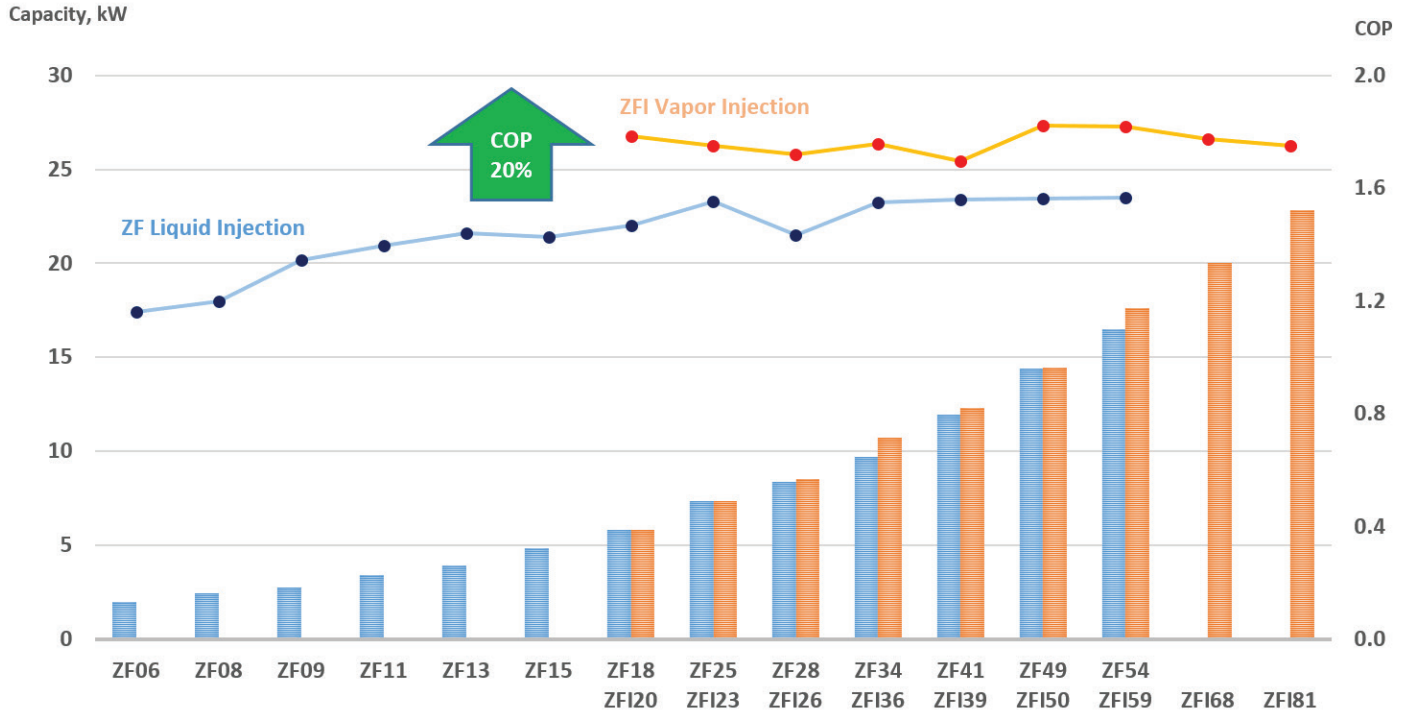

## R404A - 60Hz

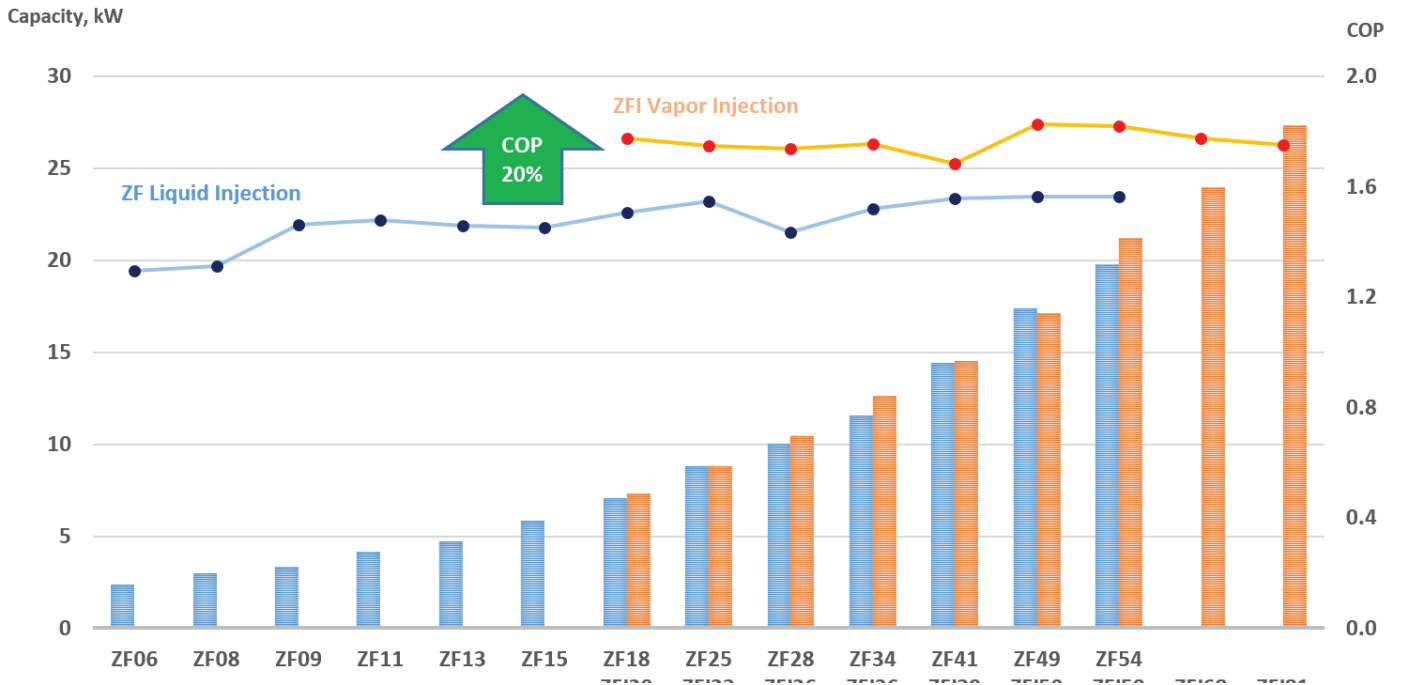

Notes: Based on low temperature cold room conditions: -25°C evaporating, 45°C condensing and 20°C return gas temperature.  
Preliminary data for ZF54, ZFI23, ZFI81. Release date to be announced.



# Performance data

# R22

TFC: 200 V ; 3-Phase, 50 Hz

TFD: 380-420 V ; 3-Phase, 50 Hz

## Liquid injection

Model			Cond. temp. °C	Evap. temp. °C										
				-40	-35	-30	-25	-20	-15	-10	-5	0	5	7
ZF06KQE	TFC	Q	30	1.15	1.46	1.82	2.24	2.73	3.31	3.98	4.75	5.62	6.62	7.05
			40	1.05	1.34	1.67	2.06	2.52	3.05	3.66	4.37	5.18	6.10	6.51
			50	0.97	1.23	1.53	1.88	2.29	2.77	3.32	3.96	4.70	5.54	5.91
	TFD	P	30	1.21	1.24	1.29	1.34	1.40	1.47	1.55	1.65	1.76	1.89	1.95
			40	1.43	1.47	1.52	1.58	1.64	1.70	1.78	1.87	1.98	2.10	2.15
			50	1.69	1.74	1.79	1.85	1.92	1.99	2.06	2.15	2.25	2.36	2.41
ZF08KQE	TFC	Q	30	1.41	1.79	2.23	2.75	3.36	4.07	4.89	5.83	6.91	8.14	8.67
			40	1.29	1.65	2.06	2.54	3.10	3.75	4.50	5.37	6.37	7.50	8.00
			50	1.19	1.51	1.89	2.32	2.82	3.40	4.08	4.87	5.78	6.82	7.27
	TFD	P	30	1.44	1.48	1.54	1.60	1.67	1.75	1.85	1.96	2.10	2.25	2.32
			40	1.70	1.76	1.81	1.88	1.95	2.03	2.12	2.23	2.35	2.50	2.56
			50	2.01	2.07	2.14	2.21	2.28	2.36	2.46	2.56	2.68	2.81	2.87
ZF09KQE	TFC	Q	30	1.59	2.01	2.50	3.09	3.78	4.58	5.52	6.58	7.80	9.18	9.78
			40	1.46	1.84	2.30	2.84	3.48	4.22	5.07	6.06	7.18	8.46	9.02
			50	1.34	1.69	2.10	2.59	3.16	3.83	4.60	5.49	6.52	7.69	8.19
	TFD	P	30	1.52	1.57	1.61	1.67	1.72	1.79	1.86	1.94	2.04	2.15	2.19
			40	1.80	1.85	1.90	1.95	2.01	2.07	2.14	2.22	2.31	2.41	2.45
			50	2.10	2.16	2.22	2.28	2.34	2.41	2.48	2.56	2.65	2.75	2.79
ZF11KQE	TFC	Q	30	1.97	2.49	3.10	3.82	4.67	5.65	6.78	8.07	9.54	11.21	11.93
			40	1.81	2.29	2.85	3.52	4.30	5.21	6.26	7.47	8.84	10.39	11.06
			50	1.65	2.08	2.59	3.19	3.89	4.71	5.67	6.77	8.03	9.46	10.09
	TFD	P	30	1.69	1.74	1.81	1.88	1.97	2.08	2.20	2.34	2.50	2.67	2.74
			40	2.00	2.06	2.13	2.21	2.30	2.40	2.52	2.65	2.80	2.97	3.04
			50	2.37	2.44	2.51	2.59	2.69	2.79	2.91	3.04	3.19	3.35	3.42
ZF13KQE	TFC	Q	30	2.29	2.89	3.60	4.44	5.44	6.60	7.95	9.49	11.24	13.22	14.08
			40	2.12	2.66	3.31	4.09	5.00	6.07	7.31	8.73	10.34	12.18	12.97
			50	1.93	2.43	3.02	3.72	4.54	5.51	6.63	7.92	9.40	11.08	11.81
	TFD	P	30	2.02	2.08	2.15	2.23	2.31	2.41	2.51	2.62	2.74	2.87	2.93
			40	2.38	2.45	2.52	2.61	2.70	2.81	2.92	3.04	3.17	3.31	3.37
			50	2.79	2.86	2.94	3.04	3.14	3.26	3.38	3.51	3.65	3.80	3.87
ZF15KQE	TFC	Q	30	2.79	3.52	4.39	5.42	6.63	8.03	9.64	11.47	13.55	15.88	16.89
			40	2.57	3.24	4.05	5.00	6.12	7.42	8.91	10.62	12.56	14.74	15.68
			50	2.33	2.94	3.67	4.53	5.55	6.73	8.10	9.67	11.45	13.47	14.35
	TFD	P	30	2.47	2.53	2.61	2.70	2.82	2.95	3.11	3.29	3.52	3.78	3.89
			40	2.89	2.97	3.06	3.15	3.27	3.40	3.55	3.74	3.95	4.19	4.30
			50	3.38	3.47	3.58	3.68	3.81	3.94	4.10	4.28	4.49	4.73	4.83
ZF18KQE	TFC	Q	30	3.25	4.12	5.17	6.42	7.89	9.60	11.58	13.85	16.42	19.33	20.59
			40	2.98	3.78	4.75	5.89	7.24	8.82	10.64	12.73	15.11	17.81	18.98
			50	2.68	3.42	4.29	5.33	6.55	7.98	9.64	11.55	13.72	16.19	17.27
	TFD	P	30	3.13	3.18	3.25	3.33	3.43	3.55	3.69	3.86	4.05	4.27	4.36
			40	3.68	3.75	3.82	3.91	4.02	4.14	4.29	4.46	4.65	4.86	4.96
			50	4.31	4.39	4.49	4.60	4.72	4.86	5.02	5.20	5.40	5.62	5.72
ZF25KQE	TFC	Q	30	4.08	5.17	6.48	8.05	9.89	12.04	14.52	17.36			
			40	3.73	4.74	5.95	7.39	9.08	11.06	13.34	15.96			
			50	3.37	4.29	5.38	6.68	8.22	10.01	12.09	14.48			
	TFD	P	30	3.93	3.99	4.07	4.17	4.30	4.45	4.63	4.84			
			40	4.62	4.70	4.79	4.90	5.04	5.19	5.38	5.59			
			50	5.40	5.50	5.62	5.76	5.92	6.09	6.29	6.52			
ZF28KQE	TFC	Q	30	4.79	6.07	7.61	9.45	11.62	14.14	17.06	20.40			
			40	4.38	5.57	6.99	8.68	10.67	12.99	15.68	18.76			
			50	3.95	5.04	6.32	7.85	9.65	11.76	14.20	17.01			
	TFD	P	30	4.72	4.79	4.88	5.01	5.16	5.34	5.55	5.80			
			40	5.54	5.63	5.75	5.88	6.04	6.23	6.45	6.70			
			50	6.48	6.61	6.75	6.91	7.10	7.31	7.55	7.82			
ZF34KQE	TFC	Q	30	5.31	6.77	8.52	10.59	13.01	15.83	19.06	22.75			
			40	4.80	6.19	7.82	9.75	11.99	14.59	17.58	20.99			
			50	4.21	5.51	7.02	8.78	10.83	13.20	15.93	19.05			
	TFD	P	30	4.32	4.50	4.68	4.87	5.06	5.26	5.46	5.66			
			40	4.95	5.21	5.46	5.71	5.95	6.19	6.42	6.64			
			50	5.67	6.02	6.36	6.68	6.98	7.27	7.53	7.77			
ZF41KQE	TFC	Q	30	6.35	8.03	10.03	12.41	15.21	18.48	22.26	26.61			
			40	5.79	7.39	9.26	11.45	14.02	17.00	20.45	24.41			
			50	5.08	6.60	8.35	10.37	12.70	15.41	18.54	22.13			
	TFD	P	30	5.24	5.49	5.75	6.01	6.27	6.53	6.80	7.06			
			40	6.05	6.38	6.71	7.03	7.35	7.66	7.97	8.27			
			50	6.95	7.36	7.76	8.16	8.53	8.90	9.26	9.61			
ZF49KQE	TFC	Q	30	7.81	9.82	12.30	15.28	18.78						
			40	7.10	8.99	11.30	14.07	17.32						
			50	6.21	7.99	10.14	12.70	15.70						
	TFD	P	30	6.48	6.68	6.94	7.25	7.59						
			40	7.52	7.76	8.08	8.45	8.86						
			50	8.78	9.07	9.43	9.86	10.32						

### Notes:

1. Q for capacity; P for power. Units in kW

2. All ZF\*KQE values are rated at return gas temperature: 20°C and subcooling: 0 K

# Performance data

# R22

TFC: 200 V ; 3-Phase, 50 Hz

TFD: 380-420 V ; 3-Phase, 50 Hz

## Vapor injection

Model			Cond. temp. °C	Evap. temp. °C										
				-40	-35	-30	-25	-20	-15	-10	-5	0	5	7
ZFI20KQE	TFC	Q	30	2.57	3.22	4.01	4.94	6.00	7.18	8.48	9.88	11.39	12.99	13.65
			40	2.55	3.21	4.00	4.91	5.93	7.07	8.31	9.64	11.06	12.57	13.20
			50	2.32	2.99	3.78	4.68	5.68	6.78	7.97	9.25	10.60	12.02	12.61
	TFD	P	30	2.14	2.18	2.27	2.40	2.55	2.72	2.91	3.10	3.28	3.45	3.51
			40	2.39	2.50	2.63	2.76	2.90	3.03	3.13	3.22	3.27	3.27	3.26
			50	2.98	3.13	3.27	3.39	3.48	3.53	3.54	3.48	3.37	3.19	3.09
	LO	30	-7.7	-6.2	-4.4	-1.8	1.3	4.9	8.8	12.8	16.7	20.6	22.0	
		40	-4.9	-3.6	-1.7	0.9	4.3	8.1	12.2	16.3	20.4	24.4	25.9	
		50	3.6	2.6	3.1	5.0	7.9	11.6	15.6	19.8	23.9	28.0	29.5	
ZFI26KQE	TFC	Q	30	3.86	4.79	5.98	7.37	8.95	10.67	12.52	14.47	16.47	18.50	19.32
			40	3.79	4.73	5.90	7.26	8.79	10.46	12.23	14.08	15.97	17.88	18.64
			50	3.44	4.39	5.55	6.89	8.39	10.00	11.71	13.47	15.27	17.07	17.78
	TFD	P	30	2.98	3.08	3.21	3.36	3.57	3.84	4.20	4.65	5.21	5.91	6.23
			40	3.37	3.57	3.75	3.93	4.11	4.31	4.56	4.86	5.24	5.70	5.92
			50	4.23	4.49	4.69	4.84	4.96	5.06	5.15	5.27	5.41	5.60	5.69
	LO	30	-5.40	-3.40	-1.70	0.50	3.50	7.20	11.50	16.20	21.10	26.10	28.10	
		40	-2.20	-0.40	1.20	3.50	6.60	10.50	15.00	19.80	24.80	29.90	32.00	
		50	6.20	5.90	6.20	7.70	10.40	14.10	18.50	23.30	28.40	33.60	35.60	
ZFI36KQE	TFC	Q	30	5.38	6.67	8.05	9.63	11.53	13.86	16.74	20.29			
			40	5.01	6.28	7.63	9.18	11.03	13.30	16.11	19.57			
			50	4.41	5.65	6.96	8.45	10.23	12.42	15.15	18.51			
	TFD	P	30	3.08	3.38	3.73	4.11	4.51	4.91	5.29	5.64			
			40	4.01	4.27	4.57	4.90	5.24	5.58	5.89	6.17			
			50	5.64	5.82	6.04	6.27	6.51	6.74	6.94	7.10			
	LO	30	-12.40	-11.80	-7.70	-3.60	-0.90	-0.30	-1.70	-5.00				
		40	-2.20	-3.10	0.10	3.60	5.80	6.10	4.40	0.90				
		50	5.20	3.80	6.80	10.30	12.40	12.60	10.80	7.20				
ZFI39KQE	TFC	Q	30	6.16	7.67	9.26	11.07	13.25	15.94	19.30	23.46			
			40	5.74	7.23	8.78	10.55	12.67	15.29	18.57	22.65			
			50	5.07	6.51	8.00	9.70	11.75	14.29	17.47	21.44			
	TFD	P	30	3.50	3.78	4.17	4.61	5.06	5.48	5.81	6.02			
			40	4.51	4.76	5.10	5.49	5.88	6.22	6.47	6.58			
			50	6.32	6.49	6.75	7.03	7.30	7.52	7.63	7.59			
	LO	30	-19.40	-14.90	-10.50	-6.90	-4.30	-3.00	-2.90	-3.80				
		40	-6.70	-5.20	-2.40	0.40	2.50	3.50	3.40	2.30				
		50	2.00	2.10	4.50	7.20	9.20	10.20	10.10	9.00				
ZFI50KQE	TFC	Q	30	7.47	9.12	10.99	13.18	15.78	18.92	22.68	27.18			
			40	6.90	8.56	10.41	12.55	15.10	18.14	21.79	26.16			
			50	6.04	7.68	9.48	11.56	14.01	16.94	20.45	24.65			
	TFD	P	30	4.09	4.42	4.87	5.39	5.92	6.40	6.78	7.00			
			40	5.26	5.56	5.96	6.42	6.88	7.28	7.56	7.66			
			50	7.40	7.59	7.89	8.23	8.55	8.79	8.91	8.84			
	LO	30	-12.90	-11.40	-7.40	-3.50	-0.90	-0.10	-1.00	-3.50				
		40	-2.20	-2.40	0.40	3.60	5.70	6.20	5.10	2.60				
		50	5.30	4.40	7.10	10.20	12.30	12.80	11.70	9.10				
ZFI59KQE	TFC	Q	30	8.80	10.89	13.12	15.69	18.77	22.57	27.26	33.03			
			40	8.19	10.25	12.44	14.95	17.95	21.65	26.22	31.85			
			50	7.19	9.20	11.33	13.75	16.65	20.22	24.65	30.13			
	TFD	P	30	5.07	5.37	5.92	6.58	7.23	7.77	8.06	7.98			
			40	6.45	6.74	7.24	7.84	8.41	8.83	8.99	8.75			
			50	9.02	9.21	9.59	10.04	10.44	10.67	10.61	10.13			
	LO	30	-11.60	-9.20	-5.00	-1.20	1.30	2.20	1.40	-0.70				
		40	-0.50	-0.20	2.70	5.80	7.80	8.40	7.50	5.10				
		50	7.30	6.60	9.30	12.30	14.30	14.90	13.90	11.50				
ZFI68KQE	TFC	Q	30	10.56	12.94	15.58	18.65	22.33						
			40	9.78	12.16	14.77	17.77	21.36						
			50	8.55	10.90	13.44	16.35	19.81						
	TFD	P	30	5.92	6.39	7.04	7.80	8.56						
			40	7.61	8.03	8.62	9.29	9.95						
			50	10.70	10.98	11.41	11.90	12.36						
	LO	30	-9.50	-8.30	-4.20	-0.20	2.30							
		40	0.70	0.30	3.30	6.70	8.80							
		50	8.20	7.10	10.00	13.20	15.20							

### Notes:

1. Q for capacity, P for power. Units in kW; LO for liquid out temperature in °C
2. All ZF\*KQE values are rated at return gas temperature: 20°C and max subcooling

# Performance data

# R22

TF7: 380 V ; 3-Phase, 60 Hz

TFC: 200 V ; 3-Phase, 60 Hz

TFD: 380-420 V ; 3-Phase, 60 Hz

## Liquid injection

Model			Cond. temp. °C	Evap. temp. °C										
				-40	-35	-30	-25	-20	-15	-10	-5	0	5	7
ZF06KQE	TFC	Q	30	1.32	1.66	2.08	2.59	3.18	3.87	4.66	5.55	6.54	7.64	8.12
			40	1.23	1.55	1.94	2.42	2.97	3.61	4.35	5.17	6.10	7.13	7.57
			50	1.15	1.44	1.80	2.22	2.73	3.32	3.98	4.74	5.59	6.54	6.94
	TFD	P	30	1.31	1.35	1.39	1.44	1.49	1.56	1.65	1.75	1.88	2.05	2.12
			40	1.57	1.60	1.64	1.67	1.71	1.77	1.85	1.95	2.07	2.23	2.30
			50	1.90	1.92	1.94	1.96	2.00	2.05	2.12	2.21	2.33	2.48	2.55
ZF08KQE	TFC	Q	30	1.68	2.11	2.64	3.29	4.04	4.92	5.92	7.05	8.32	9.72	10.32
			40	1.57	1.97	2.47	3.07	3.78	4.59	5.53	6.58	7.76	9.06	9.63
			50	1.46	1.83	2.28	2.83	3.47	4.22	5.07	6.03	7.11	8.31	8.82
	TFD	P	30	1.63	1.68	1.73	1.79	1.86	1.94	2.05	2.18	2.34	2.55	2.64
			40	1.96	2.00	2.03	2.08	2.13	2.20	2.30	2.42	2.58	2.77	2.86
			50	2.36	2.39	2.41	2.44	2.49	2.55	2.63	2.75	2.89	3.08	3.17
ZF09KQE	TFC	Q	30	1.92	2.43	3.03	3.74	4.56	5.53	6.64	7.92	9.39	11.05	11.78
			40	1.76	2.24	2.79	3.44	4.20	5.09	6.11	7.29	8.65	10.19	10.86
			50	1.62	2.05	2.56	3.14	3.82	4.62	5.54	6.61	7.85	9.25	9.87
	TFD	P	30	1.64	1.69	1.75	1.82	1.91	2.00	2.11	2.25	2.40	2.58	2.66
			40	1.95	2.01	2.07	2.15	2.23	2.32	2.43	2.55	2.69	2.86	2.93
			50	2.30	2.37	2.44	2.52	2.61	2.70	2.81	2.93	3.07	3.22	3.29
ZF11KQE	TFC	Q	30	2.38	3.01	3.75	4.62	5.64	6.81	8.16	9.71	11.46	13.45	14.31
			40	2.18	2.76	3.45	4.25	5.19	6.28	7.54	8.99	10.63	12.50	13.31
			50	1.98	2.50	3.12	3.84	4.69	5.68	6.83	8.15	9.67	11.40	12.16
	TFD	P	30	1.82	1.89	1.98	2.09	2.22	2.37	2.54	2.75	2.97	3.23	3.34
			40	2.16	2.24	2.33	2.44	2.57	2.72	2.89	3.08	3.29	3.53	3.63
			50	2.57	2.66	2.77	2.88	3.01	3.16	3.32	3.51	3.71	3.94	4.04
ZF13KQE	TF7	Q	30	2.75	3.46	4.33	5.35	6.56	7.96	9.57	11.41	13.50	15.84	16.86
			40	2.53	3.20	3.99	4.93	6.04	7.33	8.81	10.51	12.43	14.61	15.55
			50	2.29	2.90	3.62	4.47	5.47	6.64	7.99	9.54	11.31	13.30	14.17
	TFD	P	30	2.17	2.29	2.41	2.53	2.64	2.75	2.85	2.95	3.04	3.12	3.14
			40	2.55	2.67	2.80	2.94	3.08	3.22	3.37	3.53	3.68	3.83	3.90
			50	2.97	3.08	3.21	3.36	3.52	3.70	3.88	4.09	4.30	4.52	4.61
ZF15KQE	TF7	Q	30	3.38	4.27	5.32	6.57	8.02	9.70	11.63	13.82	16.30	19.07	20.27
			40	3.12	3.94	4.91	6.06	7.41	8.97	10.76	12.80	15.11	17.70	18.83
			50	2.83	3.57	4.45	5.50	6.72	8.14	9.78	11.66	13.79	16.19	17.23
	TFD	P	30	2.75	2.84	2.95	3.08	3.25	3.45	3.68	3.96	4.28	4.64	4.80
			40	3.21	3.32	3.44	3.58	3.74	3.94	4.16	4.42	4.73	5.07	5.22
			50	3.75	3.87	4.01	4.16	4.33	4.53	4.76	5.01	5.30	5.63	5.77
ZF18KQE	TF7	Q	30	3.96	5.02	6.28	7.79	9.56	11.63	14.02	16.76	19.87	23.39	24.92
			40	3.64	4.62	5.78	7.16	8.79	10.68	12.87	15.39	18.26	21.51	22.92
			50	3.30	4.20	5.25	6.50	7.97	9.68	11.67	13.96	16.58	19.56	20.86
	TFD	P	30	3.38	3.43	3.52	3.66	3.83	4.03	4.23	4.44	4.63	4.81	4.88
			40	3.94	4.01	4.12	4.29	4.48	4.70	4.94	5.18	5.41	5.62	5.70
			50	4.57	4.66	4.80	4.98	5.21	5.46	5.73	6.00	6.27	6.53	6.62
ZF25KQE	TF7	Q	30	4.97	6.29	7.88	9.76	11.99	14.58	17.57	21.01			
			40	4.57	5.79	7.25	8.98	11.02	13.39	16.14	19.30			
			50	4.14	5.26	6.58	8.15	9.99	12.14	14.63	17.51			
	TFD	P	30	4.24	4.30	4.42	4.59	4.81	5.05	5.30	5.56			
			40	4.95	5.02	5.17	5.37	5.62	5.90	6.19	6.49			
			50	5.74	5.84	6.01	6.25	6.53	6.85	7.18	7.52			
ZF28KQE	TF7	Q	30	5.84	7.39	9.25	11.47	14.09	17.13	20.65	24.68			
			40	5.37	6.81	8.52	10.55	12.94	15.73	18.96	22.67			
			50	4.87	6.18	7.74	9.57	11.74	14.26	17.19	20.57			
	TFD	P	30	5.09	5.15	5.30	5.51	5.77	6.06	6.37	6.68			
			40	5.93	6.03	6.20	6.45	6.74	7.08	7.43	7.79			
			50	6.88	7.01	7.22	7.50	7.84	8.21	8.62	9.03			
ZF34KQE	TF7	Q	30	6.39	8.16	10.26	12.76	15.68	19.07	22.96	27.41			
			40	5.78	7.45	9.43	11.74	14.45	17.58	21.17	25.28			
			50	5.08	6.63	8.46	10.58	13.05	15.91	19.19	22.95			
	TFD	P	30	5.21	5.42	5.64	5.86	6.10	6.33	6.58	6.82			
			40	5.96	6.27	6.58	6.88	7.17	7.46	7.73	8.00			
			50	6.83	7.25	7.66	8.04	8.41	8.75	9.07	9.37			
ZF41KQE	TF7	Q	30	7.65	9.67	12.09	14.95	18.32	22.26	26.82	32.06			
			40	6.98	8.90	11.16	13.80	16.89	20.48	24.64	29.42			
			50	6.12	7.95	10.06	12.49	15.31	18.57	22.33	26.66			
	TFD	P	30	6.31	6.62	6.93	7.24	7.55	7.87	8.19	8.51			
			40	7.29	7.69	8.08	8.47	8.85	9.23	9.60	9.96			
			50	8.38	8.87	9.35	9.83	10.28	10.73	11.16	11.57			
ZF49KQE	TF7	Q	30	9.41	11.83	14.81	18.40	22.63						
			40	8.55	10.83	13.62	16.96	20.87						
			50	7.49	9.62	12.22	15.30	18.91						
	TFD	P	30	7.81	8.04	8.36	8.73	9.14						
			40	9.06	9.35	9.74	10.18	10.67						
			50	10.58	10.92	11.36	11.88	12.44						

### Notes:

1. Q for capacity; P for power. Units in kW

2. All ZF\*KQE values are rated at return gas temperature: 20°C and subcooling: 0 K

# Performance data

# R22

TF7: 380 V ; 3-Phase, 60 Hz

TFC: 200 V ; 3-Phase, 60 Hz

TFD: 380-420 V ; 3-Phase, 60 Hz

## Vapor injection

Model			Cond. temp. °C	Evap. temp. °C										
				-40	-35	-30	-25	-20	-15	-10	-5	0	5	7
ZFI20KQE	TF7 TFC TFD	Q	30	3.17	3.98	4.97	6.12	7.43	8.89	10.51	12.27	14.18	16.23	17.08
			40	3.16	3.98	4.96	6.08	7.35	8.76	10.31	11.98	13.79	15.71	16.52
			50	2.88	3.72	4.70	5.81	7.05	8.42	9.90	11.50	13.22	15.04	15.79
	P	30	2.47	2.52	2.62	2.76	2.93	3.14	3.37	3.62	3.88	4.16	4.28	
		40	2.77	2.91	3.06	3.21	3.36	3.51	3.64	3.77	3.88	3.96	3.99	
		50	3.46	3.65	3.81	3.95	4.05	4.11	4.12	4.09	4.01	3.87	3.79	
	LO	30	-6.90	-5.80	-4.00	-1.40	1.80	5.30	8.90	12.50	16.00	19.30	20.50	
		40	-5.00	-4.00	-2.00	0.90	4.40	8.10	12.00	15.90	19.60	23.10	24.40	
		50	3.50	2.00	2.60	4.70	7.80	11.40	15.30	19.20	23.00	26.60	28.00	
ZFI26KQE	TF7 TFC TFD	Q	30	4.71	5.85	7.28	8.98	10.90	13.00	15.25	17.62	20.05	22.53	23.52
			40	4.64	5.78	7.20	8.86	10.72	12.75	14.90	17.15	19.45	21.77	22.69
			50	4.20	5.36	6.78	8.42	10.24	12.20	14.28	16.43	18.61	20.78	21.65
	P	30	3.51	3.64	3.79	3.98	4.23	4.56	4.99	5.54	6.24	7.10	7.50	
		40	3.95	4.20	4.42	4.63	4.85	5.10	5.41	5.79	6.27	6.86	7.14	
		50	4.99	5.30	5.53	5.70	5.84	5.97	6.09	6.25	6.45	6.72	6.86	
	LO	30	-3.00	-1.60	0.00	2.30	5.30	8.80	12.70	16.90	21.30	25.60	27.40	
		40	-0.30	0.90	2.60	5.00	8.10	11.90	16.00	20.40	24.90	29.40	31.20	
		50	7.70	6.90	7.30	9.00	11.70	15.30	19.40	23.80	28.40	33.10	34.90	
ZFI36KQE	TF7 TFC TFD	Q	30	6.46	8.01	9.66	11.55	13.83	16.65	20.14	24.46			
			40	6.01	7.54	9.16	11.00	13.23	15.97	19.38	23.59			
			50	5.29	6.79	8.35	10.13	12.27	14.92	18.21	22.30			
	P	30	3.64	3.99	4.41	4.86	5.32	5.79	6.23	6.63				
		40	4.73	5.04	5.40	5.79	6.19	6.58	6.94	7.25				
		50	6.66	6.87	7.12	7.40	7.68	7.95	8.18	8.35				
	LO	30	-10.70	-10.10	-5.90	-1.70	0.80	1.10	-0.80	-4.70				
		40	-0.40	-1.40	1.80	5.30	7.40	7.40	5.30	1.30				
		50	6.70	5.20	8.30	11.80	13.90	13.90	11.70	7.60				
ZFI39KQE	TF7 TFC TFD	Q	30	6.16	7.67	9.26	11.07	13.25	15.94	19.30	23.46			
			40	5.74	7.23	8.78	10.55	12.67	15.29	18.57	22.65			
			50	5.07	6.51	8.00	9.70	11.75	14.29	17.47	21.44			
	P	30	3.50	3.78	4.17	4.61	5.06	5.48	5.81	6.02				
		40	4.51	4.76	5.10	5.49	5.88	6.22	6.47	6.58				
		50	6.32	6.49	6.75	7.03	7.30	7.52	7.63	7.59				
	LO	30	-19.40	-14.90	-10.50	-6.90	-4.30	-3.00	-2.90	-3.80				
		40	-6.70	-5.20	-2.40	0.40	2.50	3.50	3.40	2.30				
		50	2.00	2.10	4.50	7.20	9.20	10.20	10.10	9.00				
ZFI50KQE	TF7 TFC TFD	Q	30	9.03	11.04	13.30	15.94	19.10	22.89	27.44	32.89			
			40	8.35	10.36	12.60	15.19	18.27	21.95	26.37	31.65			
			50	7.31	9.29	11.47	13.98	16.95	20.49	24.74	29.83			
	P	30	4.89	5.28	5.82	6.44	7.08	7.65	8.10	8.36				
		40	6.29	6.64	7.13	7.68	8.22	8.70	9.03	9.15				
		50	8.84	9.07	9.43	9.83	10.21	10.51	10.64	10.55				
	LO	30	-12.80	-11.30	-7.40	-3.50	-0.90	-0.10	-0.90	-3.20				
		40	-2.10	-2.40	0.50	3.60	5.70	6.20	5.30	2.80				
		50	5.20	4.40	7.10	10.20	12.30	12.80	11.80	9.30				
ZFI59KQE	TF7 TFC TFD	Q	30	10.79	13.15	15.83	18.98	22.74	27.24	32.63	39.05			
			40	9.96	12.34	15.00	18.09	21.75	26.12	31.35	37.56			
			50	8.70	11.05	13.65	16.65	20.18	24.38	29.41	35.38			
	P	30	5.87	6.45	7.12	7.85	8.62	9.37	10.09	10.74				
		40	7.63	8.14	8.72	9.36	10.01	10.65	11.23	11.74				
		50	10.77	11.12	11.53	11.98	12.43	12.86	13.23	13.51				
	LO	30	-11.50	-8.10	-4.30	-1.10	1.20	2.50	2.80	2.30				
		40	0.30	1.20	3.40	5.80	7.70	8.70	8.90	8.20				
		50	7.60	7.70	9.80	12.20	14.10	15.20	15.50	14.90				
ZFI68KQE	TF7 TFC TFD	Q	30	12.65	15.58	18.77	22.47	26.91						
			40	11.74	14.65	17.80	21.41	25.73						
			50	10.30	13.15	16.21	19.70	23.87						
	P	30	7.03	7.50	8.25	9.16	10.07							
		40	8.98	9.41	10.10	10.92	11.71							
		50	12.57	12.86	13.38	13.99	14.54							
	LO	30	-8.50	-5.20	-1.30	2.10	4.50							
		40	2.80	3.70	6.30	8.90	10.80							
		50	10.50	10.40	12.60	15.20	17.10							

**Notes:**

1. Q for capacity, P for power. Units in kW; LO for liquid out temperature in °C
2. All ZF\*KQE values are rated at return gas temperature: 20°C and max subcooling

# Performance data

# R404A/R507

TFC: 200 V ; 3-Phase, 50 Hz

TFD: 380-420 V ; 3-Phase, 50 Hz

## Liquid injection

Model			Cond. temp. °C	Evap. temp. °C										
				-40	-35	-30	-25	-20	-15	-10	-5	0	5	7
ZF06KQE	TFC	Q	30	1.28	1.61	1.99	2.46	3.00	3.63	4.36	5.21	6.17	7.26	7.74
			40	1.12	1.42	1.77	2.17	2.64	3.19	3.83	4.56	5.40	6.36	6.78
			50	0.95	1.21	1.50	1.84	2.24	2.70	3.23	3.85	4.56	5.38	5.73
	TFD	P	30	1.17	1.23	1.30	1.37	1.45	1.54	1.64	1.75	1.87	2.00	2.05
			40	1.40	1.46	1.52	1.59	1.67	1.76	1.85	1.96	2.08	2.20	2.26
			50	1.72	1.77	1.82	1.89	1.96	2.04	2.13	2.24	2.35	2.47	2.52
ZF08KQE	TFC	Q	30	1.57	1.97	2.45	3.02	3.68	4.46	5.36	6.40	7.59	8.93	9.51
			40	1.38	1.75	2.17	2.67	3.25	3.92	4.71	5.61	6.64	7.82	8.34
			50	1.17	1.49	1.85	2.26	2.75	3.31	3.97	4.73	5.61	6.61	7.05
	TFD	P	30	1.39	1.47	1.54	1.63	1.73	1.84	1.95	2.08	2.22	2.37	2.44
			40	1.67	1.74	1.81	1.89	1.99	2.09	2.21	2.33	2.47	2.62	2.69
			50	2.05	2.10	2.17	2.25	2.33	2.43	2.54	2.66	2.79	2.94	3.00
ZF09KQE	TFC	Q	30	1.70	2.16	2.70	3.34	4.08	4.95	5.95	7.11	8.43	9.93	10.58
			40	1.52	1.93	2.40	2.94	3.59	4.33	5.20	6.20	7.35	8.67	9.24
			50	1.31	1.66	2.05	2.51	3.04	3.66	4.38	5.23	6.21	7.33	7.82
	TFD	P	30	1.46	1.48	1.52	1.57	1.65	1.74	1.84	1.96	2.09	2.23	2.29
			40	1.77	1.78	1.81	1.86	1.92	2.00	2.10	2.21	2.33	2.47	2.52
			50	2.16	2.16	2.18	2.22	2.27	2.34	2.43	2.53	2.65	2.78	2.84
ZF11KQE	TFC	Q	30	2.16	2.73	3.39	4.17	5.08	6.14	7.38	8.81	10.47	12.36	13.18
			40	1.93	2.44	3.01	3.69	4.47	5.39	6.46	7.71	9.15	10.81	11.54
			50	1.64	2.08	2.57	3.13	3.78	4.55	5.45	6.50	7.73	9.16	9.79
	TFD	P	30	1.79	1.82	1.87	1.94	2.03	2.14	2.27	2.41	2.57	2.75	2.83
			40	2.13	2.15	2.20	2.26	2.34	2.45	2.57	2.70	2.85	3.02	3.09
			50	2.53	2.56	2.60	2.67	2.75	2.85	2.97	3.10	3.24	3.40	3.47
ZF13KQE	TFC	Q	30	2.44	3.14	3.96	4.91	6.01	7.27	8.71	10.33	12.15	14.19	15.07
			40	2.18	2.77	3.46	4.29	5.24	6.35	7.62	9.07	10.71	12.55	13.35
			50	1.93	2.38	2.93	3.60	4.39	5.31	6.39	7.64	9.07	10.69	11.40
	TFD	P	30	1.87	1.93	2.00	2.08	2.19	2.30	2.44	2.59	2.76	2.95	3.03
			40	2.27	2.33	2.41	2.49	2.59	2.70	2.83	2.97	3.13	3.30	3.37
			50	2.78	2.85	2.93	3.02	3.12	3.23	3.35	3.48	3.62	3.78	3.85
ZF15KQE	TFC	Q	30	3.00	3.88	4.89	6.06	7.41	8.98	10.78	12.85	15.21	17.88	19.04
			40	2.65	3.40	4.26	5.27	6.44	7.80	9.38	11.21	13.30	15.69	16.73
			50	2.34	2.93	3.61	4.41	5.36	6.48	7.80	9.35	11.14	13.21	14.12
	TFD	P	30	2.21	2.33	2.45	2.58	2.73	2.90	3.09	3.31	3.56	3.85	3.97
			40	2.68	2.82	2.95	3.09	3.24	3.41	3.60	3.80	4.04	4.30	4.41
			50	3.26	3.42	3.58	3.73	3.90	4.07	4.25	4.45	4.67	4.92	5.02
ZF18KQE	TFC	Q	30	3.69	4.68	5.82	7.17	8.75	10.60	12.77	15.28	18.19	21.52	22.98
			40	3.28	4.15	5.15	6.30	7.66	9.25	11.12	13.30	15.83	18.75	20.04
			50	2.79	3.54	4.38	5.34	6.46	7.78	9.34	11.17	13.32	15.83	16.94
	TFD	P	30	2.79	2.89	3.01	3.14	3.29	3.46	3.65	3.85	4.07	4.30	4.40
			40	3.29	3.40	3.53	3.67	3.83	4.00	4.18	4.38	4.59	4.82	4.91
			50	3.92	4.04	4.18	4.33	4.49	4.67	4.85	5.05	5.26	5.48	5.57
ZF25KQE	TFC	Q	30	4.57	5.79	7.29	9.05	11.05	13.27	15.69	18.31			
			40	4.07	5.10	6.39	7.92	9.68	11.65	13.80	16.12			
			50	3.61	4.41	5.46	6.74	8.22	9.89	11.73	13.72			
	TFD	P	30	3.03	3.31	3.54	3.76	4.00	4.30	4.67	5.16			
			40	3.43	3.80	4.11	4.39	4.69	5.03	5.44	5.95			
			50	3.84	4.31	4.72	5.09	5.46	5.85	6.32	6.87			
ZF28KQE	TFC	Q	30	5.23	6.62	8.33	10.34	12.62	15.16	17.94	20.92			
			40	4.65	5.82	7.30	9.05	11.07	13.31	15.77	18.42			
			50	4.13	5.04	6.24	7.70	9.40	11.30	13.41	15.68			
	TFD	P	30	3.74	4.08	4.37	4.64	4.94	5.30	5.76	6.37			
			40	4.23	4.68	5.07	5.42	5.78	6.20	6.71	7.34			
			50	4.74	5.32	5.82	6.28	6.73	7.22	7.79	8.48			
ZF34KQE	TFC	Q	30	6.00	7.69	9.63	11.89	14.51	17.56	21.08	25.14			
			40	5.27	6.78	8.49	10.46	12.73	15.36	18.42	21.95			
			50	4.44	5.75	7.20	8.84	10.73	12.92	15.47	18.44			
	TFD	P	30	4.18	4.41	4.67	4.93	5.22	5.53	5.85	6.20			
			40	4.85	5.16	5.46	5.77	6.08	6.40	6.73	7.07			
			50	5.66	6.04	6.41	6.77	7.13	7.48	7.82	8.16			
ZF41KQE	TFC	Q	30	7.54	9.58	11.92	14.63	17.82	21.54	25.88	30.93			
			40	6.68	8.51	10.57	12.91	15.63	18.81	22.52	26.85			
			50	5.61	7.24	9.00	10.96	13.22	15.84	18.92	22.52			
	TFD	P	30	5.07	5.40	5.75	6.11	6.48	6.88	7.30	7.75			
			40	5.95	6.33	6.72	7.12	7.52	7.94	8.36	8.81			
			50	6.95	7.40	7.85	8.29	8.74	9.18	9.63	10.09			
ZF49KQE	TFC	Q	30	9.10	11.49	14.33	17.68	21.59						
			40	8.03	10.16	12.65	15.57	18.95						
			50	6.75	8.60	10.73	13.18	16.02						
	TFD	P	30	6.24	6.53	6.90	7.33	7.81						
			40	7.36	7.67	8.06	8.52	9.02						
			50	8.73	9.07	9.48	9.97	10.51						

**Notes:**

1. Q for capacity; P for power. Units in kW

2. All ZF\*KQE values are rated at return gas temperature: 20°C and subcooling: 0 K

# Performance data

# R404A/R507

TFC: 200 V ; 3-Phase, 50 Hz

TFD: 380-420 V ; 3-Phase, 50 Hz

## Vapor injection

Model			Cond. temp. °C	Evap. temp. °C										
				-40	-35	-30	-25	-20	-15	-10	-5	0	5	7
ZFI20KQE	TFC	Q	30	3.43	4.27	5.22	6.29	7.49	8.85	10.39	12.12	14.06	16.25	17.20
			40	3.25	4.06	4.98	6.03	7.22	8.58	10.12	11.87	13.85	16.08	17.05
			50	2.92	3.69	4.58	5.61	6.79	8.15	9.70	11.48	13.48	15.73	16.71
	TFD	P	30	2.17	2.23	2.30	2.38	2.46	2.53	2.58	2.62	2.62	2.59	2.57
			40	2.74	2.78	2.85	2.93	3.01	3.09	3.16	3.22	3.26	3.27	3.27
			50	3.56	3.58	3.62	3.69	3.75	3.83	3.90	3.97	4.02	4.05	4.05
	LO	30	-13.50	-9.80	-6.10	-2.00	2.30	6.50	10.50	14.20	17.40	20.00	20.90	
		40	-6.70	-4.80	-2.20	1.00	4.60	8.30	12.00	15.40	18.20	20.60	21.40	
		50	6.00	4.80	5.10	6.50	8.90	11.60	14.50	17.20	19.70	21.80	22.50	
ZFI26KQE	TFC	Q	30	5.13	6.28	7.60	9.13	10.88	12.88	15.17	17.75	20.69	23.98	25.41
			40	5.09	6.11	7.31	8.72	10.37	12.27	14.46	16.97	19.82	23.01	24.41
			50	5.08	5.96	7.02	8.30	9.81	11.59	13.67	16.06	18.78	21.89	23.24
	TFD	P	30	3.22	3.39	3.55	3.70	3.84	3.98	4.12	4.24	4.37	4.50	4.56
			40	3.86	4.08	4.28	4.47	4.65	4.82	4.97	5.12	5.26	5.39	5.45
			50	4.75	5.02	5.27	5.50	5.71	5.91	6.08	6.24	6.39	6.53	6.58
	LO	30	-13.00	-8.10	-4.00	-0.10	3.70	7.20	10.50	13.60	16.10	18.10	18.80	
		40	-10.10	-5.20	-0.80	3.30	7.30	10.90	14.20	17.10	19.50	21.50	22.10	
		50	-7.30	-2.10	2.60	7.00	11.10	14.90	18.20	21.00	23.40	25.10	25.70	
ZFI36KQE	TFC	Q	30	6.47	8.00	9.74	11.69	13.83	16.17	18.69	21.40			
			40	6.28	7.66	9.25	11.06	13.07	15.29	17.70	20.27			
			50	6.23	7.40	8.80	10.41	12.23	14.26	16.49	18.91			
	TFD	P	30	3.78	4.05	4.30	4.53	4.75	4.97	5.20	5.43			
			40	4.47	4.87	5.22	5.53	5.80	6.06	6.28	6.48			
			50	5.22	5.79	6.30	6.73	7.10	7.43	7.69	7.92			
	LO	30	-13.80	-10.00	-5.40	-0.70	3.90	8.10	12.00	15.40				
		40	-10.80	-5.80	-0.50	4.50	9.10	13.20	16.90	20.20				
		50	-11.10	-3.70	3.00	9.00	14.20	18.50	22.30	25.40				
ZFI39KQE	TFC	Q	30	7.43	9.18	11.18	13.41	15.87	18.55	21.45	24.56			
			40	7.21	8.79	10.62	12.69	15.00	17.54	20.31	23.28			
			50	7.15	8.49	10.10	11.94	14.03	16.36	18.92	21.69			
	TFD	P	30	4.50	4.81	5.11	5.38	5.65	5.91	6.18	6.45			
			40	5.31	5.78	6.20	6.57	6.90	7.20	7.46	7.71			
			50	6.20	6.89	7.49	8.00	8.44	8.83	9.15	9.41			
	LO	30	-13.80	-10.00	-5.40	-0.70	3.90	8.10	12.00	15.40				
		40	-10.80	-5.80	-0.50	4.50	9.00	13.20	16.90	20.10				
		50	-11.10	-3.70	3.00	9.00	14.20	18.50	22.30	25.40				
ZFI50KQE	TFC	Q	30	9.11	10.79	12.97	15.61	18.65	22.02	25.67	29.53			
			40	8.65	10.28	12.37	14.88	17.74	20.89	24.28	27.84			
			50	8.03	9.62	11.65	14.04	16.75	19.70	22.85	26.15			
	TFD	P	30	5.05	5.43	5.77	6.08	6.38	6.68	6.99	7.32			
			40	6.07	6.50	6.89	7.27	7.62	7.97	8.34	8.73			
			50	7.32	7.80	8.26	8.68	9.10	9.51	9.93	10.39			
	LO	30	-18.10	-7.60	-2.60	0.50	3.40	6.70	10.50	14.80				
		40	-12.10	-2.70	1.90	5.00	8.10	11.70	15.70	20.20				
		50	-3.60	3.70	7.30	10.10	13.10	16.70	20.80	25.20				
ZFI59KQE	TFC	Q	30	11.09	13.13	15.79	19.01	22.70	26.81	31.25	35.95			
			40	10.53	12.51	15.06	18.12	21.61	25.46	29.58	33.92			
			50	9.78	11.73	14.18	17.10	20.40	23.98	27.84	31.82			
	TFD	P	30	6.16	6.61	7.03	7.42	7.78	8.14	8.52	8.92			
			40	7.40	7.92	8.40	8.86	9.30	9.73	10.18	10.65			
			50	8.93	9.52	10.07	10.60	11.11	11.60	12.12	12.67			
	LO	30	-15.40	-5.10	-0.30	2.70	5.60	8.80	12.60	16.70				
		40	-9.50	-0.30	4.20	7.20	10.20	13.60	17.50	21.80				
		50	-1.20	5.90	9.50	12.10	15.00	18.60	22.50	26.90				
ZFI68KQE	TFC	Q	30	12.58	14.89	17.91	21.57	25.76						
			40	11.95	14.20	17.10	20.55	24.51						
			50	11.09	13.30	16.10	19.40	23.14						
	TFD	P	30	7.16	7.69	8.17	8.62	9.05						
			40	8.61	9.21	9.78	10.30	10.81						
			50	10.38	11.07	11.71	12.32	12.91						
	LO	30	-15.40	-5.10	-0.30	2.70	5.50							
		40	-9.60	-0.40	4.10	7.20	10.20							
		50	-1.20	5.90	9.40	12.10	15.00							

### Notes:

1. Q for capacity, P for power. Units in kW; LO for liquid out temperature in °C
2. All ZF\*KQE values are rated at return gas temperature: 20°C and max subcooling



# Performance data

# R404A/R507

TF7: 380 V ; 3-Phase, 60 Hz

TFC: 200 V ; 3-Phase, 60 Hz

TFD: 380-420 V ; 3-Phase, 60 Hz

## Liquid injection

Model			Cond. temp. °C	Evap. temp. °C										
				-40	-35	-30	-25	-20	-15	-10	-5	0	5	7
ZF06KQE	TFC	Q	30	1.49	1.89	2.35	2.89	3.51	4.25	5.10	6.10	7.25	8.57	9.15
			40	1.29	1.66	2.07	2.54	3.09	3.72	4.46	5.31	6.31	7.45	7.96
			50	1.11	1.44	1.79	2.18	2.63	3.15	3.75	4.46	5.29	6.25	6.67
	TFD	P	30	1.27	1.29	1.34	1.43	1.52	1.63	1.74	1.84	1.93	1.99	2.00
			40	1.57	1.57	1.60	1.67	1.77	1.88	2.00	2.12	2.22	2.32	2.34
			50	1.94	1.90	1.92	1.97	2.06	2.17	2.30	2.43	2.56	2.68	2.72
ZF08KQE	TFC	Q	30	1.89	2.38	2.96	3.65	4.45	5.39	6.48	7.74	9.17	10.79	11.50
			40	1.67	2.11	2.62	3.22	3.93	4.74	5.69	6.78	8.03	9.45	10.07
			50	1.41	1.80	2.23	2.74	3.32	4.01	4.80	5.72	6.77	7.99	8.52
	TFD	P	30	1.57	1.63	1.71	1.80	1.92	2.04	2.17	2.32	2.46	2.61	2.66
			40	1.91	1.95	2.01	2.09	2.20	2.32	2.45	2.60	2.75	2.91	2.98
			50	2.40	2.40	2.44	2.50	2.59	2.69	2.82	2.96	3.11	3.27	3.34
ZF09KQE	TFC	Q	30	2.10	2.66	3.31	4.07	4.96	5.99	7.20	8.59	10.19	12.02	12.81
			40	1.86	2.35	2.92	3.58	4.35	5.24	6.28	7.49	8.89	10.49	11.19
			50	1.59	2.01	2.49	3.04	3.68	4.43	5.30	6.32	7.51	8.88	9.48
	TFD	P	30	1.58	1.63	1.69	1.78	1.88	2.01	2.15	2.31	2.49	2.68	2.76
			40	1.92	1.95	2.01	2.09	2.18	2.30	2.44	2.59	2.76	2.95	3.03
			50	2.34	2.37	2.41	2.48	2.56	2.67	2.80	2.95	3.12	3.30	3.38
ZF11KQE	TFC	Q	30	2.59	3.28	4.10	5.05	6.17	7.46	8.96	10.68	12.64	14.86	15.82
			40	2.31	2.92	3.63	4.46	5.43	6.55	7.86	9.36	11.08	13.04	13.89
			50	1.98	2.50	3.09	3.78	4.59	5.53	6.63	7.91	9.38	11.06	11.80
	TFD	P	30	1.90	1.97	2.06	2.18	2.33	2.50	2.70	2.92	3.17	3.45	3.57
			40	2.30	2.37	2.46	2.57	2.71	2.86	3.05	3.25	3.48	3.74	3.85
			50	2.79	2.86	2.95	3.06	3.19	3.35	3.52	3.71	3.93	4.17	4.27
ZF13KQE	TF7	Q	30	2.93	3.78	4.77	5.91	7.21	8.69	10.37	12.25	14.35	16.68	17.69
			40	2.58	3.30	4.14	5.13	6.27	7.59	9.09	10.79	12.71	14.85	15.78
			50	2.26	2.81	3.47	4.27	5.23	6.35	7.64	9.13	10.83	12.75	13.58
	TFC	P	30	2.24	2.30	2.39	2.50	2.65	2.82	3.03	3.28	3.56	3.89	4.03
			40	2.70	2.76	2.85	2.95	3.09	3.25	3.44	3.67	3.92	4.22	4.35
			50	3.30	3.37	3.45	3.55	3.68	3.83	4.01	4.21	4.45	4.71	4.83
ZF15KQE	TF7	Q	30	3.73	4.70	5.86	7.22	8.82	10.69	12.86	15.35	18.20	21.43	22.84
			40	3.28	4.14	5.14	6.32	7.70	9.31	11.18	13.35	15.83	18.67	19.91
			50	2.79	3.51	4.35	5.32	6.46	7.80	9.36	11.19	13.30	15.72	16.79
	TFC	P	30	2.70	2.79	2.92	3.07	3.26	3.49	3.78	4.13	4.54	5.02	5.24
			40	3.19	3.34	3.49	3.66	3.85	4.07	4.32	4.62	4.96	5.36	5.54
			50	3.77	3.98	4.19	4.40	4.62	4.84	5.08	5.36	5.66	6.01	6.16
ZF18KQE	TF7	Q	30	4.44	5.65	7.04	8.67	10.57	12.79	15.37	18.36	21.80	25.73	27.45
			40	3.96	5.02	6.22	7.62	9.24	11.15	13.37	15.96	18.96	22.41	23.92
			50	3.45	4.34	5.34	6.48	7.82	9.39	11.24	13.41	15.95	18.90	20.20
	TFC	P	30	3.27	3.37	3.52	3.72	3.96	4.24	4.55	4.88	5.23	5.59	5.73
			40	3.88	3.98	4.13	4.34	4.59	4.87	5.19	5.53	5.88	6.24	6.39
			50	4.57	4.68	4.85	5.07	5.33	5.63	5.96	6.31	6.68	7.05	7.20
ZF25KQE	TF7	Q	30	5.50	6.98	8.75	10.82	13.22	15.99	19.14	22.71			
			40	4.90	6.16	7.68	9.48	11.61	14.08	16.92	20.17			
			50	4.41	5.38	6.60	8.09	9.89	12.01	14.50	17.36			
	TFC	P	30	3.63	3.96	4.28	4.60	4.90	5.21	5.53	5.87			
			40	4.06	4.50	4.91	5.30	5.68	6.04	6.41	6.78			
			50	4.46	5.03	5.56	6.06	6.52	6.97	7.40	7.82			
ZF28KQE	TF7	Q	30	6.28	7.98	9.99	12.36	15.10	18.26	21.86	25.94			
			40	5.60	7.04	8.77	10.83	13.26	16.08	19.33	23.04			
			50	5.04	6.15	7.54	9.24	11.29	13.72	16.56	19.83			
	TFC	P	30	4.47	4.89	5.29	5.67	6.05	6.43	6.83	7.25			
			40	5.00	5.55	6.06	6.54	7.00	7.45	7.90	8.36			
			50	5.50	6.21	6.86	7.47	8.05	8.59	9.12	9.64			
ZF34KQE	TF7	Q	30	7.18	9.21	11.53	14.23	17.37	21.02	25.24	30.10			
			40	6.30	8.12	10.17	12.52	15.24	18.39	22.05	26.27			
			50	5.31	6.88	8.62	10.58	12.85	15.47	18.53	22.08			
	TFC	P	30	5.08	5.37	5.68	6.01	6.36	6.73	7.13	7.55			
			40	5.91	6.28	6.65	7.02	7.40	7.79	8.19	8.60			
			50	6.89	7.35	7.80	8.25	8.68	9.10	9.52	9.93			
ZF41KQE	TF7	Q	30	9.09	11.54	14.36	17.63	21.46	25.95	31.19	37.27			
			40	8.05	10.26	12.73	15.56	18.83	22.66	27.13	32.35			
			50	6.76	8.72	10.84	13.21	15.93	19.09	22.79	27.14			
	TFC	P	30	6.11	6.51	6.92	7.36	7.81	8.29	8.80	9.34			
			40	7.17	7.63	8.10	8.57	9.06	9.56	10.08	10.61			
			50	8.37	8.92	9.45	9.99	10.52	11.06	11.60	12.15			
ZF49KQE	TF7	Q	30	10.96	13.85	17.27	21.30	26.01						
			40	9.67	12.24	15.25	18.75	22.84						
			50	8.13	10.36	12.92	15.88	19.30						
	TFC	P	30	7.52	7.87	8.31	8.83	9.41						
			40	8.86	9.24	9.71	10.26	10.87						
			50	10.52	10.92	11.43	12.01	12.67						

### Notes:

1. Q for capacity; P for power. Units in kW

2. All ZF\*KQE values are rated at return gas temperature: 20°C and subcooling: 0 K

# Performance data

# R404A/R507

TF7: 380 V ; 3-Phase, 60 Hz

TFC: 200 V ; 3-Phase, 60 Hz

TFD: 380-420 V ; 3-Phase, 60 Hz

## Vapor injection

Model			Cond. temp. °C	Evap. temp. °C										
				-40	-35	-30	-25	-20	-15	-10	-5	0	5	7
ZFI20KQE	TF7	Q	30	4.26	5.27	6.39	7.68	9.13	10.79	12.66	14.77	17.12	19.78	20.93
			40	4.20	5.16	6.24	7.47	8.87	10.47	12.29	14.35	16.68	19.26	20.39
			50	4.00	4.90	5.94	7.12	8.47	10.03	11.80	13.80	16.07	18.63	19.73
	TFC	P	30	2.65	2.80	2.93	3.05	3.17	3.27	3.35	3.43	3.49	3.55	3.57
			40	3.25	3.42	3.58	3.73	3.86	3.99	4.11	4.21	4.31	4.39	4.43
			50	4.00	4.20	4.38	4.56	4.72	4.88	5.02	5.16	5.29	5.41	5.46
	TFD	LO	30	-9.30	-6.50	-3.30	0.20	3.90	7.70	11.30	14.50	17.50	19.80	20.60
			40	-9.40	-6.00	-2.40	1.60	5.70	9.80	13.50	16.90	19.80	22.20	22.90
			50	-7.10	-3.50	0.40	4.70	8.90	13.00	16.80	20.10	22.90	25.10	25.80
ZFI26KQE	TF7	Q	30	6.29	7.80	9.46	11.32	13.41	15.78	18.47	21.51	24.93	28.81	30.50
			40	6.02	7.46	9.03	10.77	12.73	14.94	17.45	20.30	23.52	27.16	28.75
			50	5.63	6.98	8.44	10.06	11.86	13.91	16.22	18.85	21.84	25.22	26.69
	TFC	P	30	3.81	4.05	4.30	4.55	4.81	5.07	5.35	5.65	5.97	6.33	6.49
			40	4.50	4.84	5.16	5.46	5.76	6.05	6.34	6.64	6.96	7.30	7.44
			50	5.47	5.90	6.29	6.65	6.99	7.31	7.62	7.93	8.23	8.55	8.68
	TFD	LO	30	-12.20	-8.00	-4.10	-0.10	3.90	7.80	11.30	14.40	17.20	19.20	19.90
			40	-9.60	-4.70	-0.20	4.30	8.60	12.60	16.20	19.30	21.90	23.90	24.50
			50	-5.80	-0.30	4.80	9.60	14.10	18.20	21.80	24.90	27.40	29.20	29.80
ZFI36KQE	TF7	Q	30	7.72	9.57	11.60	13.89	16.53	19.60	23.19	27.34			
			40	7.52	9.13	10.95	13.05	15.53	18.46	21.90	25.96			
			50	7.73	8.98	10.46	12.26	14.44	17.09	20.29	24.15			
	TFC	P	30	4.47	4.84	5.16	5.45	5.73	6.04	6.38	6.80			
			40	5.26	5.75	6.17	6.57	6.96	7.36	7.81	8.32			
			50	6.28	6.86	7.39	7.89	8.38	8.90	9.46	10.09			
	TFD	LO	30	-12.60	-9.00	-4.10	0.60	4.70	7.70	9.80	11.00			
			40	-9.90	-3.90	2.10	7.10	10.80	13.40	14.90	15.50			
			50	-16.10	-3.90	5.40	12.10	16.70	19.50	20.90	21.00			
ZFI39KQE	TF7	Q	30	8.88	11.01	13.34	15.98	19.02	22.55	26.67	31.45			
			40	8.65	10.51	12.60	15.02	17.86	21.23	25.20	29.86			
			50	8.90	10.34	12.04	14.10	16.61	19.67	23.35	27.78			
	TFC	P	30	5.35	5.80	6.19	6.53	6.87	7.23	7.65	8.15			
			40	6.30	6.89	7.40	7.87	8.34	8.83	9.36	9.98			
			50	7.52	8.22	8.85	9.46	10.05	10.67	11.33	12.10			
	TFD	LO	30	-12.60	-9.00	-4.10	0.60	4.70	7.70	9.80	11.00			
			40	-9.90	-3.90	2.10	7.10	10.80	13.40	14.90	15.50			
			50	-16.10	-3.90	5.40	12.10	16.70	19.50	20.90	21.00			
ZFI50KQE	TF7	Q	30	10.78	12.76	15.35	18.48	22.06	26.06	30.37	34.94			
			40	10.24	12.17	14.64	17.61	21.01	24.74	28.76	32.97			
			50	9.51	11.40	13.78	16.62	19.83	23.33	27.06	30.94			
	TFC	P	30	5.96	6.40	6.81	7.18	7.53	7.88	8.24	8.64			
			40	7.16	7.67	8.14	8.58	9.00	9.42	9.85	10.31			
			50	8.64	9.22	9.75	10.26	10.75	11.24	11.74	12.27			
	TFD	LO	30	-15.40	-5.10	-0.30	2.70	5.60	8.80	12.60	16.70			
			40	-9.50	-0.40	4.20	7.20	10.20	13.60	17.50	21.80			
			50	-1.20	5.90	9.50	12.10	15.00	18.50	22.50	26.90			
ZFI59KQE	TF7	Q	30	13.36	15.82	19.03	22.91	27.35	32.30	37.65	43.31			
			40	12.69	15.07	18.15	21.83	26.03	30.67	35.64	40.87			
			50	11.78	14.13	17.09	20.60	24.58	28.89	33.54	38.34			
	TFC	P	30	7.42	7.97	8.47	8.94	9.37	9.81	10.26	10.75			
			40	8.91	9.54	10.12	10.68	11.20	11.72	12.26	12.84			
			50	10.76	11.47	12.13	12.77	13.38	13.97	14.61	15.26			
	TFD	LO	30	-15.40	-5.10	-0.30	2.70	5.60	8.80	12.60	16.70			
			40	-9.50	-0.30	4.20	7.20	10.20	13.60	17.50	21.80			
			50	-1.20	5.90	9.50	12.10	15.00	18.60	22.50	26.90			
ZFI68KQE	TF7	Q	30	15.10	17.88	21.50	25.89	30.93						
			40	14.35	17.05	20.52	24.67	29.42						
			50	13.32	15.96	19.32	23.28	27.78						
	TFC	P	30	8.59	9.23	9.81	10.35	10.87						
			40	10.33	11.06	11.74	12.36	12.97						
			50	12.46	13.28	14.06	14.79	15.50						
	TFD	LO	30	-15.40	-5.10	-0.30	2.70	5.50						
			40	-9.60	-0.40	4.10	7.20	10.20						
			50	-1.20	5.90	9.40	12.10	15.00						

**Notes:**

1. Q for capacity, P for power. Units in kW; LO for liquid out temperature in °C
2. All ZF\*KQE values are rated at return gas temperature: 20°C and max subcooling

# Technical data

Compressor model		Liquid injection												
		ZF06KQE	ZF08KQE	ZF09KQE	ZF11KQE	ZF13KQE	ZF15KQE	ZF18KQE	ZF25KQE	ZF28KQE	ZF34KQE	ZF41KQE	ZF49KQE	
Nominal horsepower	HP	2	2.5	3	3.5	4	5	6	7.5	9	10	13	15	
Displacement	m <sup>3</sup> /hr	5.9	7.3	8.0	10.0	11.7	14.4	17.1	21.4	25.1	29.1	35.3	42.4	
Motor type	50Hz	TFD	TFD	TFD	TFD	TFD	TFD	TFD	TFD	TFD	TFD	TFD	TFD	
		TFC	TFC	TFC	TFC	TFC	TFC	TFC	TFC	TFC	TFC	TFC	TFC	
	60Hz	TFD	TFD	TFD	TFD	TFD	TFD	TFD	TFD	TFD	TFD	TFD	TFD	
		TFC	TFC	TFC	TFC	TFC	TFC	TFC	TFC	TFC	TFC	TFC	TFC	
Locked rotor current (LRA)	50Hz	TFD	TFD	TFD	TFD	TFD	TFD	TFD	TFD	TFD	TFD	TFD	TFD	
		TFC	TFC	TFC	TFC	TFC	TFC	TFC	TFC	TFC	TFC	TFC	TFC	
	60Hz	TFD	TFD	TFD	TFD	TFD	TFD	TFD	TFD	TFD	TFD	TFD	TFD	
		TFC	TFC	TFC	TFC	TFC	TFC	TFC	TFC	TFC	TFC	TFC	TFC	
Maximum operating current (MOC)	50Hz	TFD	TFD	TFD	TFD	TFD	TFD	TFD	TFD	TFD	TFD	TFD	TFD	
		TFC	TFC	TFC	TFC	TFC	TFC	TFC	TFC	TFC	TFC	TFC	TFC	
	60Hz	TFD	TFD	TFD	TFD	TFD	TFD	TFD	TFD	TFD	TFD	TFD	TFD	
		TFC	TFC	TFC	TFC	TFC	TFC	TFC	TFC	TFC	TFC	TFC	TFC	
Maximum continuous current (MCC)	50Hz	TFD	TFD	TFD	TFD	TFD	TFD	TFD	TFD	TFD	TFD	TFD	TFD	
		TFC	TFC	TFC	TFC	TFC	TFC	TFC	TFC	TFC	TFC	TFC	TFC	
	60Hz	TFD	TFD	TFD	TFD	TFD	TFD	TFD	TFD	TFD	TFD	TFD	TFD	
		TFC	TFC	TFC	TFC	TFC	TFC	TFC	TFC	TFC	TFC	TFC	TFC	
Rated load current (RLA=MCC/1.4)	50Hz	TFD	TFD	TFD	TFD	TFD	TFD	TFD	TFD	TFD	TFD	TFD	TFD	
		TFC	TFC	TFC	TFC	TFC	TFC	TFC	TFC	TFC	TFC	TFC	TFC	
	60Hz	TFD	TFD	TFD	TFD	TFD	TFD	TFD	TFD	TFD	TFD	TFD	TFD	
		TFC	TFC	TFC	TFC	TFC	TFC	TFC	TFC	TFC	TFC	TFC	TFC	
Rated load current (RLA=MCC/1.56)	50Hz	TFD	TFD	TFD	TFD	TFD	TFD	TFD	TFD	TFD	TFD	TFD	TFD	
		TFC	TFC	TFC	TFC	TFC	TFC	TFC	TFC	TFC	TFC	TFC	TFC	
	60Hz	TFD	TFD	TFD	TFD	TFD	TFD	TFD	TFD	TFD	TFD	TFD	TFD	
		TFC	TFC	TFC	TFC	TFC	TFC	TFC	TFC	TFC	TFC	TFC	TFC	
Winding resistance at 25 °C	TFD	TFD	TFD	TFD	TFD	TFD	TFD	TFD	TFD	TFD	TFD	TFD	TFD	
	TFC	TFC	TFC	TFC	TFC	TFC	TFC	TFC	TFC	TFC	TFC	TFC	TFC	
	TF7	TF7	TF7	TF7	TF7	TF7	TF7	TF7	TF7	TF7	TF7	TF7	TF7	
Connection size	Rotalock connection													
	Suction	in	1 1/4	1 1/4	1 1/4	1 1/4	1 1/4	1 1/4	1 1/4	1 1/4	1 1/4	1 3/4	1 3/4	1 3/4
	Discharge	in	1	1	1	1	1	1	1	1 1/4	1 1/4	1 1/4	1 1/4	1 1/4
	Injection	in	11/16	11/16	11/16	11/16	11/16	11/16	11/16	11/16	11/16	1	1	1
	Brazing connection													
	Suction	in	NA	NA	NA	NA	7/8	7/8	7/8	7/8	7/8	7/8	1 3/8	1 3/8
Discharge	in	NA	NA	NA	NA	1/2	1/2	1/2	3/4	3/4	7/8	7/8	7/8	
Injection	in	NA	NA	NA	NA	1 1/16 ( Rotalock only)					1 (Rotalock only)			
Outline dimension	Length	mm	246	246	246	246	246	246	246	246	280	280	280	
	Width	mm	246	246	246	246	257	257	257	257	280	280	280	
	Height	mm	369	391	391	405	442	442	442	442	451	534	534	552
Sight glass fitting thread	in	1 1/4"-12UNF					1 1/4"-12UNF					1 1/4"-12UNF		
Oil quantity	L	1.3	1.5	1.5	1.5	1.9	1.9	1.9	1.9	1.9	3.4	3.4	3.4	
Net weight	kg	25	27	27	29	39	39	39	39	40	63	63	66	
Terminal box IP grade		IP21					IP21 (Except ZF28KQE-TFC with IP54)					IP54		
Crankcase heater power	W	70					70					90		
Mounting parts Installation size (hole size)	mm	190 x 190 (Ø19)												

# Technical data

Compressor model			Vapor injection						
			ZFI20KQE	ZFI26KQE	ZFI36KQE	ZFI39KQE	ZFI50KQE	ZFI59KQE	ZFI68KQE
Nominal horsepower		HP	4	6	7.5	9	10	13	15
Displacement		m <sup>3</sup> /hr	11.7	17.1	21.4	25.1	29.1	35.3	42.4
Motor type	50Hz		TFD	TFD	TFD	TFD	TFD	TFD	TFD
			TFC	TFC	TFC	TFC	TFC	TFC	TFC
	60Hz		TFD	TFD	TFD	TFD	TFD	TFD	TFD
			TFC	TFC	TFC	TFC	TFC	TFC	TFC
Locked rotor current (LRA)	50Hz	Amps	TFD	74.0	102.0	121.4	100.0	118.0	139.0
			TFC	135.0	172.0	223.0	197.9	220.0	248.0
	60Hz	Amps	TFD	70.0	99.0	121.4	100.0	125.0	139.0
			TFC	123.0	156.0	224.0	199.0	239.0	248.0
Maximum operating current (MOC)	50Hz	Amps	TFD	13.7	16.0	18.1	25.0	29.0	30.0
			TFC	18.0	26.0	36.7	37.2	51.4	57.7
	60Hz	Amps	TFD	13.7	16.0	18.1	25.0	29.0	30.0
			TFC	18.0	26.0	36.7	37.2	51.4	57.7
Maximum continuous current (MCC)	50Hz	Amps	TFD	13.0	16.6	20.3	25.0	27.0	28.3
			TFC	24.0	28.5	35.3	42.6	52.0	59.0
	60Hz	Amps	TFD	13.0	18.5	20.3	25.0	27.0	28.3
			TFC	24.0	30.5	38.2	42.6	52.0	59.0
Rated load current (RLA=MCC/1.4)	50Hz	Amps	TFD	9.3	11.9	14.5	17.9	19.3	20.2
			TFC	17.1	20.4	25.2	30.4	37.1	42.1
	60Hz	Amps	TFD	9.3	11.9	14.5	17.9	19.3	20.2
			TFC	17.1	21.8	27.3	30.4	37.1	42.1
Rated load current (RLA=MCC/1.56)	50Hz	Amps	TFD	12.5	14.5	17.4	20.4	21.7	28.9
			TFC	10.0	12.5	14.5	17.4	20.4	21.7
	60Hz	Amps	TFD	8.3	10.6	13.0	16.0	17.3	18.1
			TFC	15.4	18.3	22.6	27.3	33.3	37.8
Winding resistance at 25 °C	Ohm	TFD	2.27	1.74	1.63	1.24	1.24	1.09	
		TFC	0.69	0.56	0.39	0.37	0.31	0.28	0.22
		TF7	2.23	1.92	1.20	1.06	0.85	0.85	0.56
Connection size	Rotalock connection								
	Suction	in	1 1/4	1 1/4	1 1/4	1 1/4	1 3/4	1 3/4	1 3/4
	Discharge		1	1	1 1/4	1 1/4	1 1/4	1 1/4	1 1/4
	Injection		1	1	1	1	1	1	1
	Brazing connection								
	Suction	in	7/8	7/8	7/8	7/8	1 3/8	1 3/8	1 3/8
Discharge	1/2		1/2	3/4	3/4	7/8	7/8	7/8	
Injection	1/2		1/2	1/2	1/2	5/8	5/8	5/8	
Outline dimension	Length	mm	246	246	246	246	328	328	328
	Width		257	257	257	257	297	297	297
	Height		442	442	442	451	534	534	552
Sight glass fitting thread		in	1 1/4"-12UNF				1 1/4"-12UNF		
Oil quantity		L	1.9	1.9	1.9	1.9	3.4	3.4	3.4
Net weight		kg	39	39	39	40	63	63	66
Terminal box IP grade			IP21 (Except ZFI39KQE-TFC with IP54)				IP54		
Crankcase heater power		W	70				90		
Mounting parts Installation size (hole size)		mm	190 x 190 (Ø19)						

# EVI CoreSense™ control kits and wiring diagram

## EVI CoreSense control kits

### Introduction

The EVI CoreSense control kit of ZFI compressor is intended to control vapor injection, maintain a safe discharge temperature, and provide intelligent diagnosis and protection.

The kit includes a printed circuit board (PCB), an electronic expansion valve (EXV), and three sensors, as well as containing a transformer and an EXV filter. All parts are common, except the EXV valve orifice size, which will be applied to different ZFI models.

In vapor injection application, the valve is driven by sensors mounted near the heat exchanger and attempts to maintain the vapor outlet sensor 5K higher than the vapor inlet. The system will switch to discharge line temperature control if vapor injection is insufficient to maintain a safe discharge temperature. If the discharge temperature becomes dangerously high, the system will stop the compressor, turn on an LED alarm, and trigger a voltage free alarm relay contact. The compressor can auto-reset, but not lockout.

Emerson provides customer EVI CoreSense control kits with and without CoreSense box.

EVI CoreSense control kits			
Part number without CoreSense box	Part number with CoreSense box	Apply for ZFI models	EXV valve orifice size (Identification code)
562-0313-00	562-0291-01	ZFI20~ZFI26	Ø1.3mm (TS113C03)
562-0313-01	562-0291-02	ZFI36~ZFI59	Ø1.65mm (TS116C03)
562-0313-02	562-0291-03	ZFI68	Ø1.8mm (TS118C03)

### Printed circuit board

Wear a ground strap when working with the PCB to avoid the risk of damage from static discharges.

General PCB layout, input and output ports are shown in the image below, the ports to EXV, DLT, as well as the vapor in and vapor out sensors are done with Poka-yoke connector design. Connect sensors, EXV, and system wiring as shown in wiring diagram.

The PCB is supplied power through a transformer with a power input of 50/60Hz, 220VAC, and an output of 12VAC to the PCB board.

For EVI control kits with CoreSense box, the board and transformer are both mounted in the box, using 4x05mm holes at 61x101mm centers, fastened by screws. Spare part number is 543-0189-01 for field service.

For EVI control kits without CoreSense™ box, we provide individual parts for compact system design. The board is with 4 x Ø4mm holes at 61 x 101mm centers, please use plastic stakes provided. Spare part number is 543-0219-01 for field service.

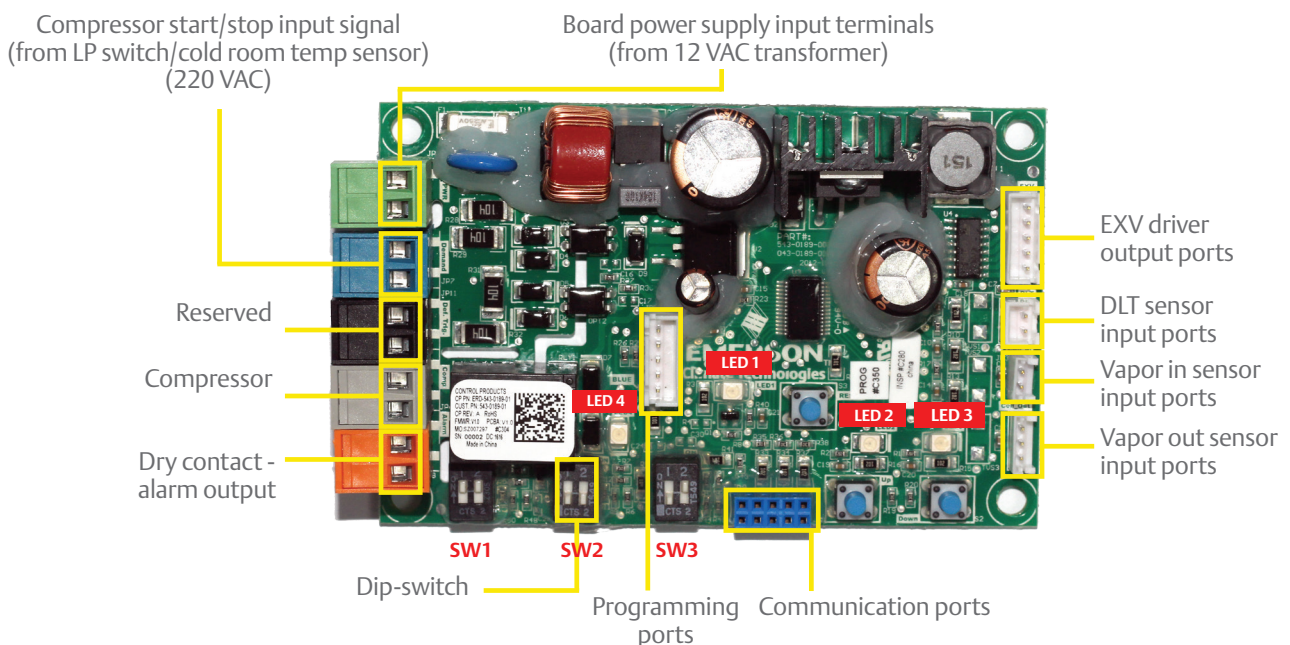

## Dip-switch setting

The dip-switch default setting has been done in-factory, please do not change setting and ensure that the replacement board is set correctly.

For the glide-refrigerants application like R407A, R407F, R407C, we would recommend 10K superheat. Please contact your local Emerson sales and application engineer to reset the dip-switch.

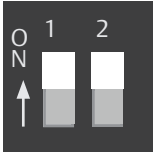
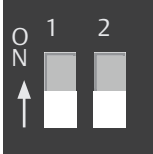
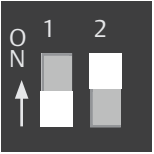
Dip-switch default factory setting			
	SW1	SW2	SW3
BIT1	ON	OFF	OFF
BIT2	ON	OFF	ON
Dip-switch Setting position			
Function description of default setting	<ol style="list-style-type: none"> <li>1. Discharge Line Temperature (DLT) control target <math>\leq 110^{\circ}\text{C}</math></li> <li>2. Vapor out superheat target is 5K</li> <li>3. Compressor will shut down if DLT above <math>125^{\circ}\text{C}</math></li> <li>4. Compressor can auto-reset and no lockout due to DLT overheat protection</li> <li>5. Compressor minimum stop time is 0 minute</li> <li>6. Vapor injection mode</li> </ol>		

## LED functions

### LED1 (yellow-green)

LED1 will light up during initialization after power on, after that, blinking lights will indicate the sensor status.

LED	Color	Compressor or sensor status	LED1 behavior
LED1	Yellow-Green	Idle compressor waiting to start	Blinks at 1 Hz
		DLT overheat protection	Blinks 2 times at 1Hz, waiting 5s, then repeat...
		DLT failure	Blinks 3 times at 1Hz, waiting 5s, then repeat...
		Vapor in sensor failure	Blinks 4 times at 1Hz, waiting 5s, then repeat...
		Vapor out sensor failure	Blinks 5 times at 1Hz, waiting 5s, then repeat...

### LED2, LED3 (yellow-green)

LED2 and LED3 will blink once when entering or exiting EXV manual operation, and also indicate EXV opening and closing.

LED	Color	EXV status	LED2, LED3 behavior
LED2 LED3	Yellow-Green	Opening	LED2 is flashing at 1Hz, LED3 off
		Closing	LED3 is flashing at 1Hz, LED2 off
		Fully open	LED2 constant on, LED3 off
		Fully closed	LED3 constant on, LED2 off



## LED4 (red color) alarm

LED4 will turn on when alarm is triggered by the following items

LED	Color	Sensor status	LED4 behavior
LED4	Red	DLT overheat protection	LED4 turn on red
		DLT sensor failure	LED4 turn on red
		Vapor in sensor failure	LED4 turn on red
		Vapor out sensor failure	LED4 turn on red

## Temperature sensors

The EVI kits include 3 temperature sensors. Please ensure all sensors are mounted in the correct locations, fastened, and insulated properly.

The discharge temperature sensor should be installed approximately 178mm (7 inches) from discharge tube outlet. If a service valve is installed at the discharge tube, the sensor should be located 127mm (5 inches) from the valve braze.

The vapor in sensor is connected to the pipe between the EXV and PHE. The vapor out sensor is connected to the pipe from the PHE to the compressor vapor injection port. Please don't make the vapor in and vapor out sensor location reversed.

Sensor	Wire length	Resistance value vs. temperature	Open	Short
Discharge temperature sensor	930mm	351.6 kΩ @0°C 100.0 kΩ @25°C 5.8 kΩ @100°C	>1000kΩ	<400Ω
Vapor in sensor	1360mm	28.1 kΩ @0°C 10.0 kΩ @25°C 0.9 kΩ @100°C	>500kΩ	<500Ω
Vapor out sensor	750mm	28.1 kΩ @0°C 10.0 kΩ @25°C 0.9 kΩ @100°C	>500kΩ	<500Ω

## Electronic expansion valve (EXV)

The EXV contains an EXV-valve and EXV-coil, lead wire length for coil is 1796mm, the valve size includes Ø1.3mm, Ø1.65mm and Ø1.8mm depending on system size, applied to different ZFI models.

The liquid refrigerant should pass from the bending tube and flow out from the straight tube. Please weld the filter before the EXV provided along with the kits.

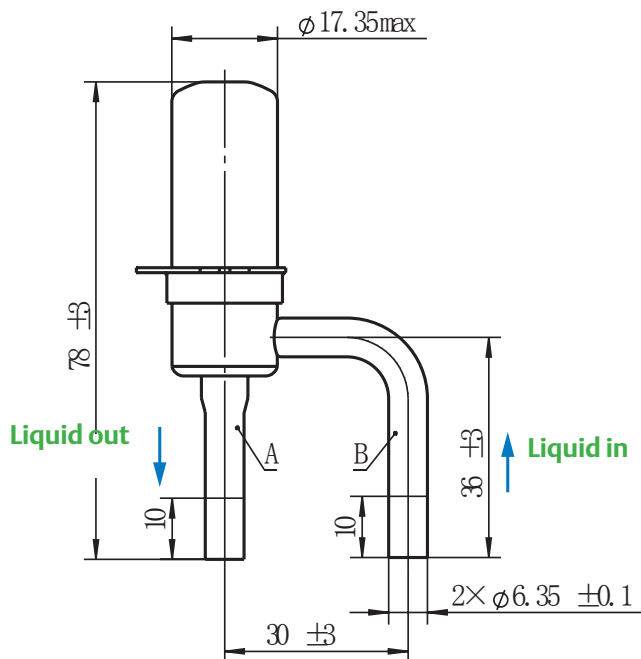

EXV valve connection size, mm

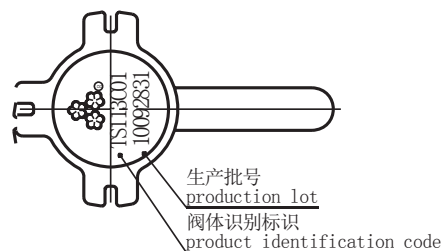

阀体识别标识说明:  
Product identification code specific

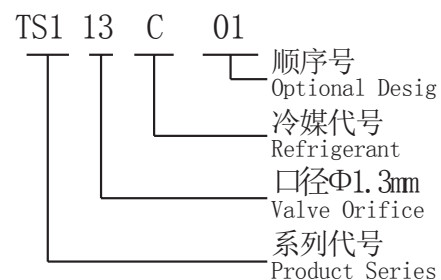

EXV valve identification code

## ZFI standard control box wiring example

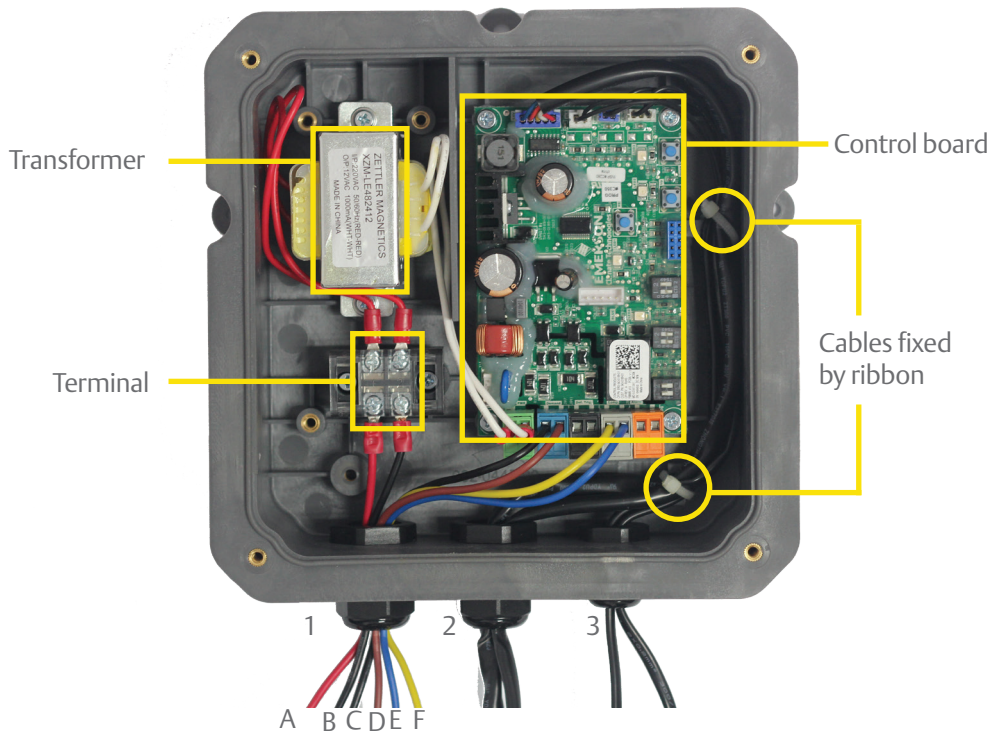

Waterproof gland no.	Gland 1	Gland 2	Gland 3
Wire function	A (red) and B (black): Controller power supply input (220–240 VAC 50/60 Hz)	EXV coil Vapor in sensor Vapor out sensor	DLT sensor
	C (black) and D (brown): Compressor start/stop input (220–240 VAC 50/60 Hz)		
	E (blue) and F (yellow): Compressors contactor coil Control output		
Wire connection	Wires A and B: Connect to terminal	Connect to the EXV, vapor in/out sensor at the top edge of the control board	Connect to the DLT port at the top edge of the control board
	Wires C and D: Connect to the blue connector on the control board		
	Wires E and F: Connect to the gray connector on the control board		
Gland internal diameter range	2–3 mm		
Jacket line requirement	Internal wire size: 18 AWG		
	Rated voltage: 300 V/600 V		
	Rated temperature: 80/105 °C		
	Recommended: UL105, UL1011, UL1007		

# Wiring diagram

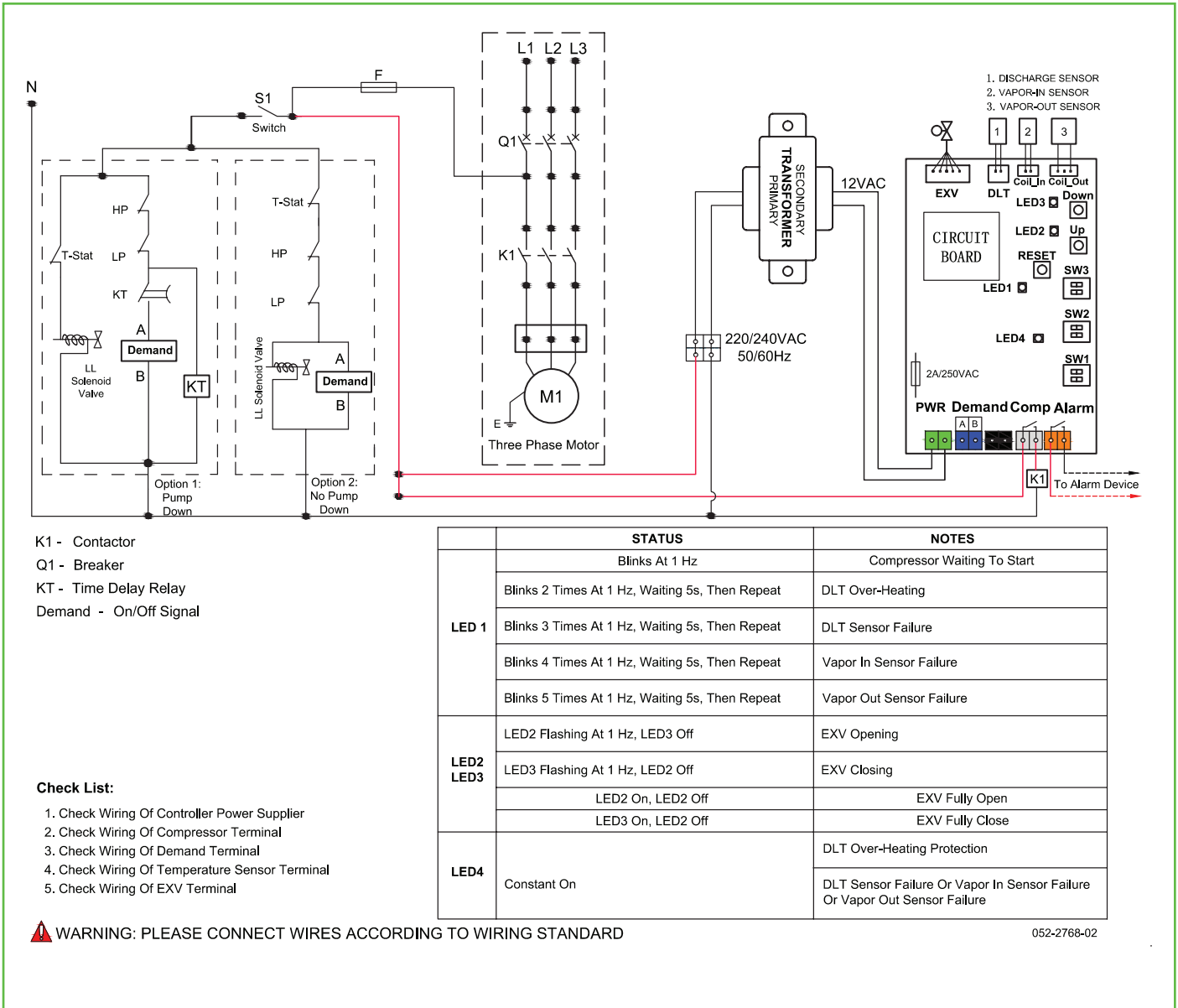

## Plate heat exchanger (PHE) and liquid line temperature

Mount plate heat exchanger in the vertical position and oriented correctly. Ensure that sensors are located correctly as well.

ZFI vapor injection compressors can deliver very cold liquid with economizer cycle. The sub-cooling of liquid line calls for these recommendations:

1. Liquid line pipe connecting the economizer to the evaporator expansion valve should be well-insulated separately.
2. The lower liquid line temperature can increase the evaporator valve capacities. Please follow the valve manufacturer's recommended liquid temperature correction factors for proper selection of evaporator expansion valve. Refer to product catalogue or select software for liquid line temperature.

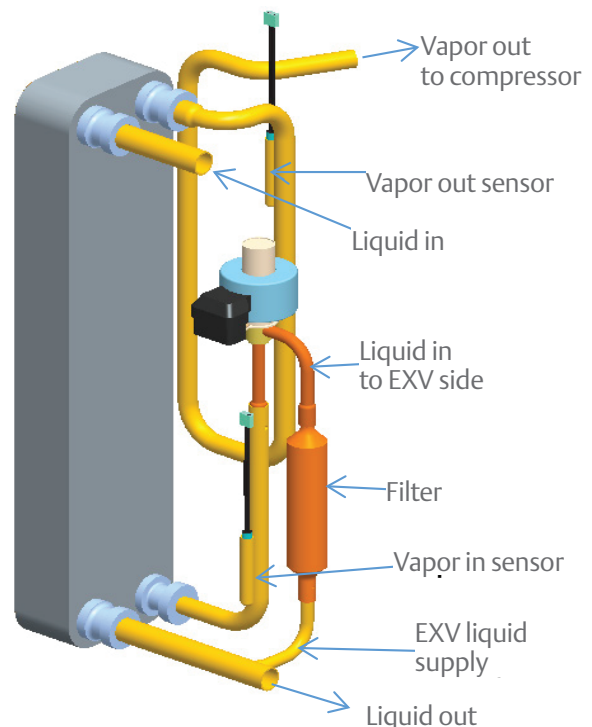

# Dimensional drawings

## ZF06KQE - ZF11KQE (BOM 551) Rotalock connection

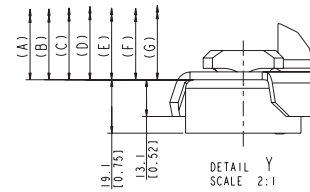
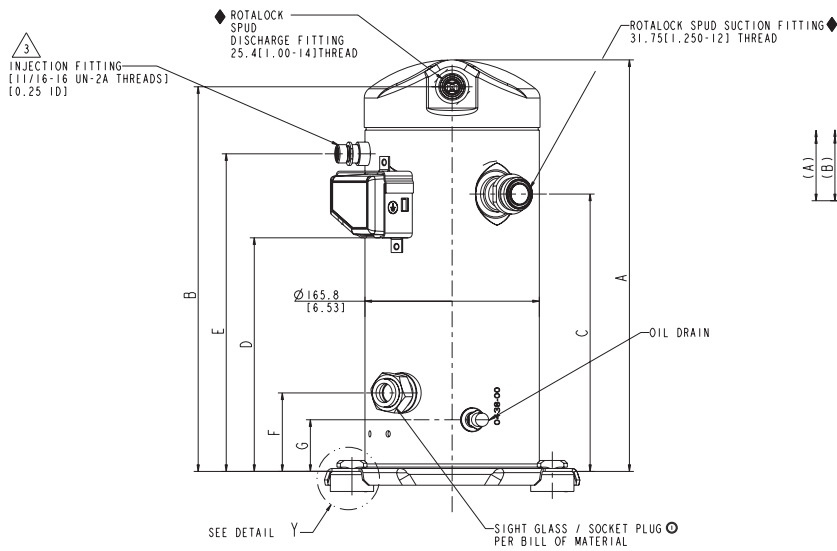
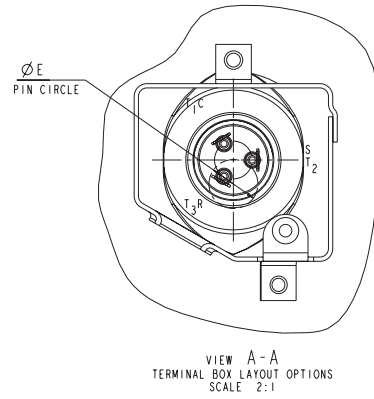
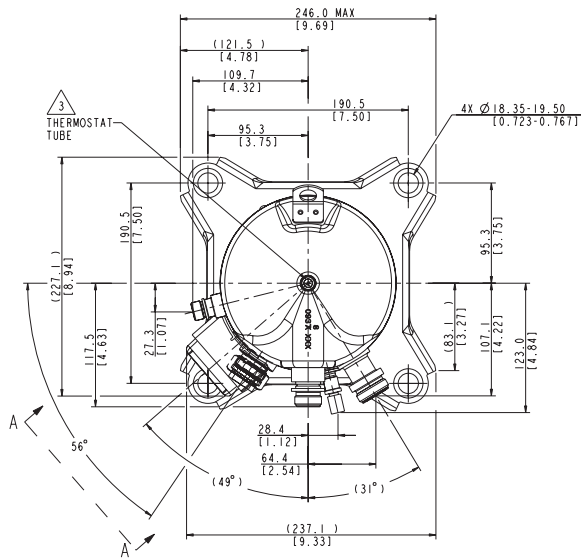

Model number	mm[in]						
	A±3.0	B	C	D±3.0	E	F	G
ZF06KQE	368.7 [14.52]	343.1 [13.51]	243.8 [9.60]	202.2 [7.96]	279.4 [11.00]	68.9 [2.71]	43.4 [1.70]
ZF08KQE	391.3 [15.41]	365.7 [14.40]	263.7 [10.38]	222.1 [8.74]	302.0 [11.88]	74.6 [2.93]	49.1 [1.93]
ZF09KQE	391.3 [15.41]	365.7 [14.40]	263.7 [10.38]	222.1 [8.74]	302.0 [11.88]	74.6 [2.93]	49.1 [1.93]
ZF11KQE	405.0 [15.94]	379.4 [14.94]	276.4 [10.88]	234.8 [9.24]	315.7 [12.42]	74.6 [2.93]	49.1 [1.93]

### Notes:

- (1) All tolerances ± 1.5mm [0.06in] unless otherwise specified
- (2) Due to accumulated assembly tolerances, the listed components may vary from the mounting holes. All fittings: ± 3.0mm [0.12in]
- (3) Tube ends must be plugged
- (4) Rotalock fittings are shown
- (5) All units are in mm[inch]

# Dimensional drawings

## ZF13KQE - ZF28KQE (BOM 551) Rotalock connection

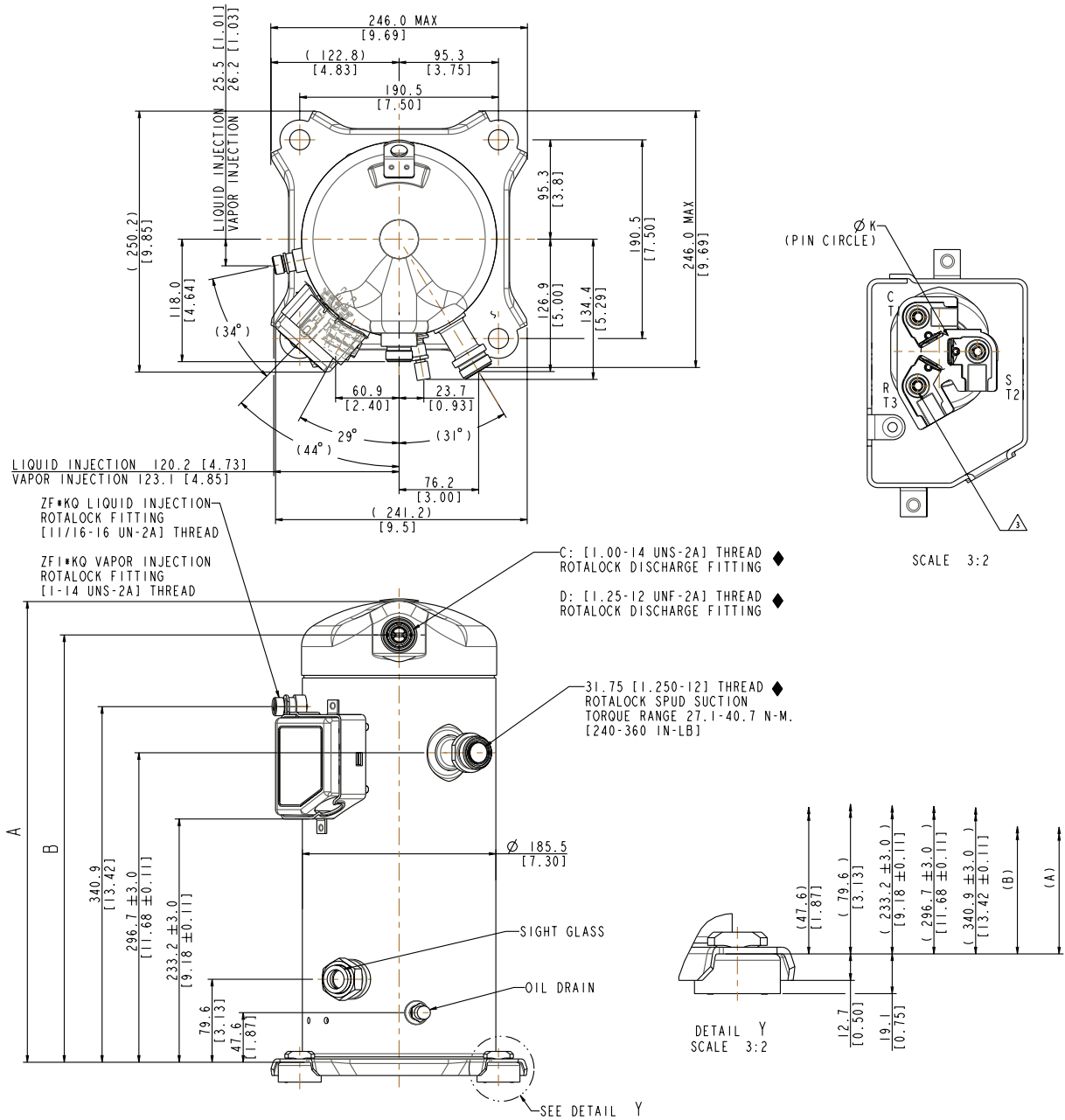

Model number	mm[in]		Discharge fitting
	A±3.0	B±3.0	
ZF13KQE	442.0 [17.40]	409.6 [16.13]	C
ZF15KQE			
ZF18KQE			
ZF25KQE	451.0 [17.76]	418.6 [16.48]	D
ZF28KQE			

### Notes:

- (1) All tolerances ± 1.5mm [0.06in] unless otherwise specified
- (2) Due to accumulated assembly tolerances, the listed components may vary from the mounting holes. All fittings: ± 3.0mm [0.12in]
- (3) Tube ends must be plugged
- (4) Rotalock fittings are shown
- (5) All units are in mm[inch]

# Dimensional drawings

## ZFI20KQE - ZFI39KQE (BOM 552) Rotalock connection

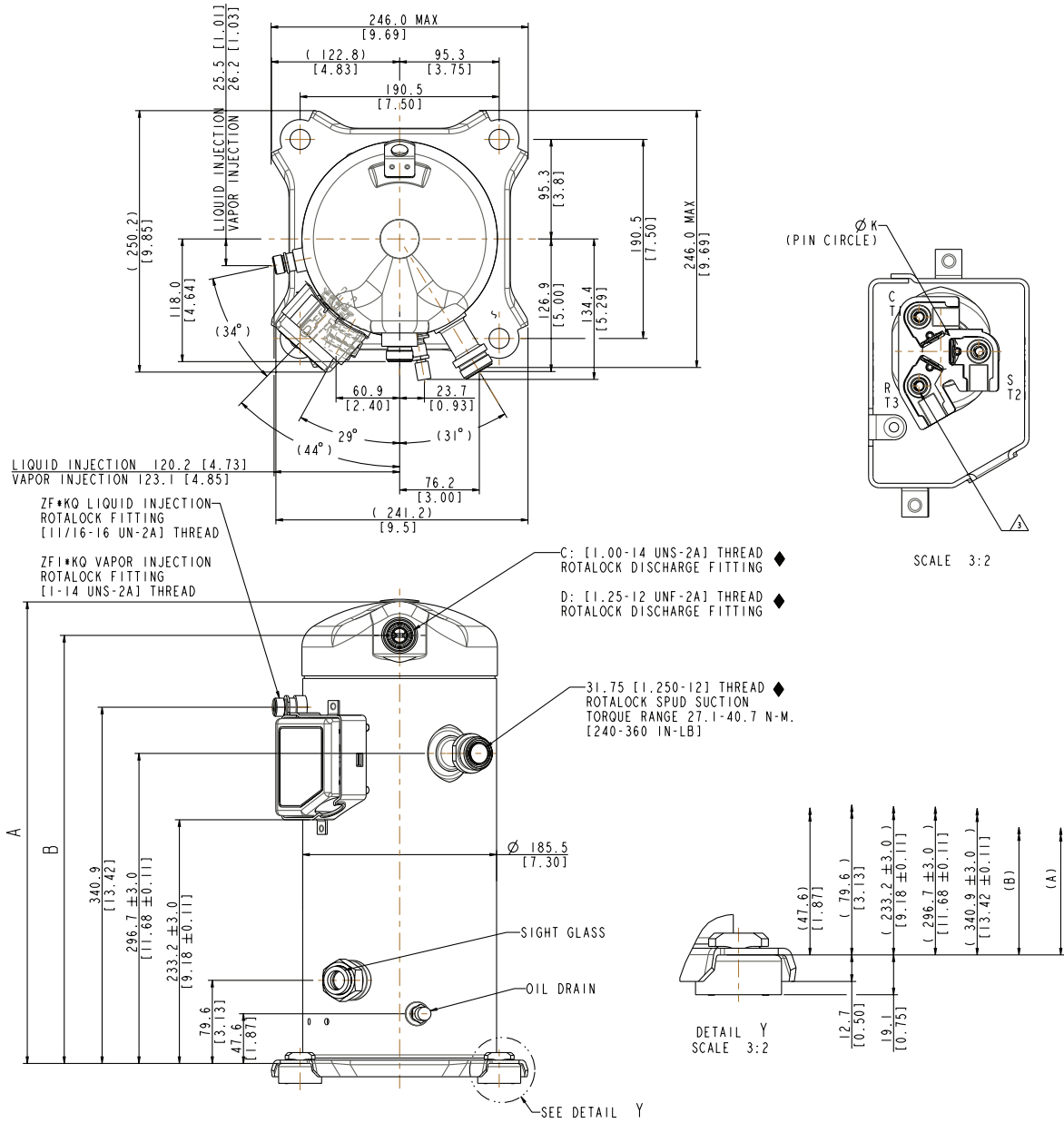

Model number	mm[in]		Discharge fitting
	A±3.0	B	
ZFI20KQE	442.0 [17.40]	409.6 [16.13]	C
ZFI26KQE			D
ZFI36KQE	451.0 [17.76]	418.6 [16.48]	D
ZFI39KQE			

### Notes:

- (1) All tolerances ± 1.5mm [0.06in] unless otherwise specified
- (2) Due to accumulated assembly tolerances, the listed components may vary from the mounting holes. All fittings: ± 3.0mm [0.12in]
- (3) Tube ends must be plugged
- (4) Rotalock fittings are shown
- (5) All units are in mm[inch]



# Dimensional drawings

## ZF34KQE - ZF49KQE (BOM 564) Rotalock connection

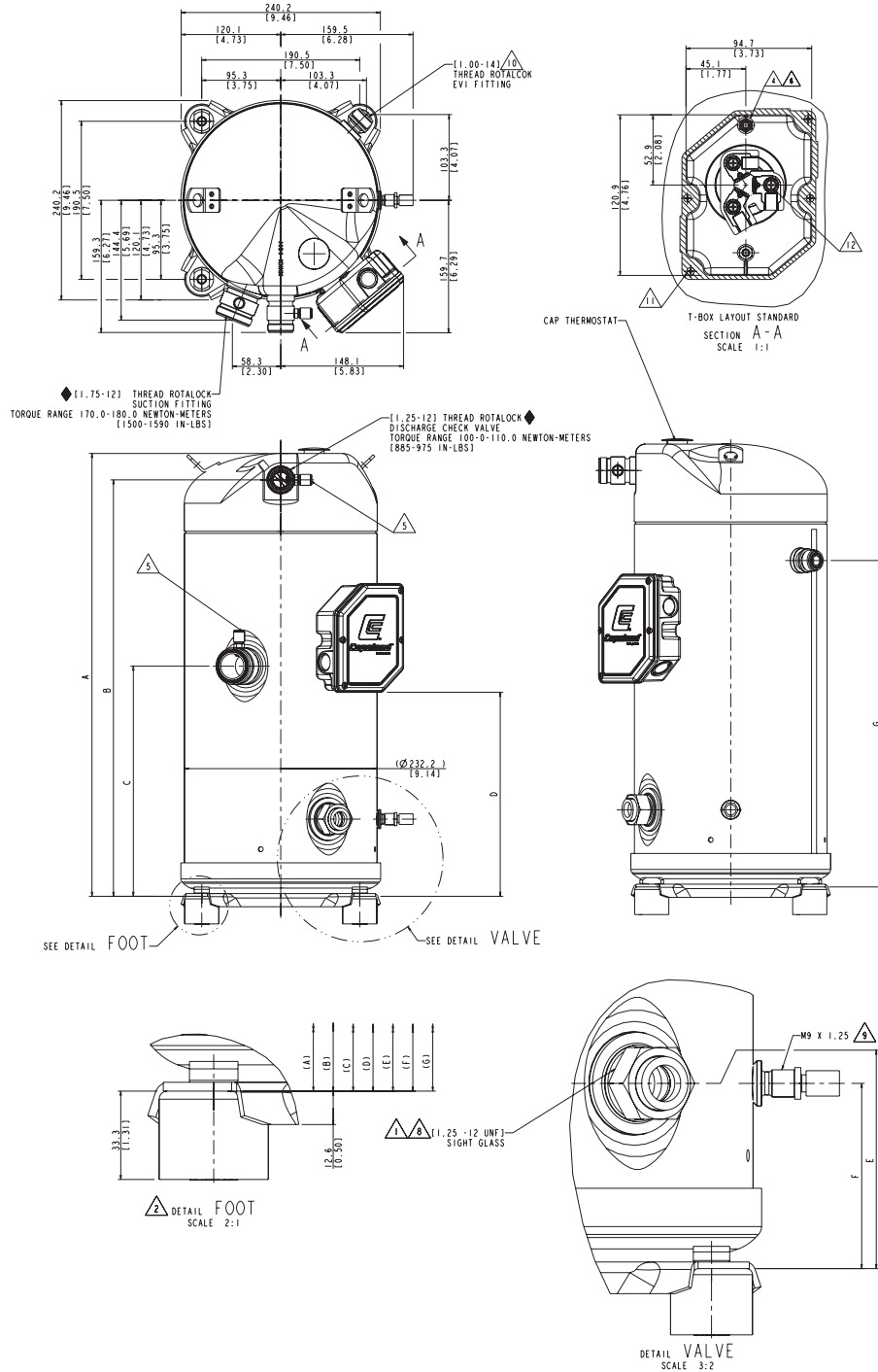

Model number	mm[in]						
	A	B	C	D	E	F	G
ZF34KQE	533.6 [21.0]	501.8 [19.75]	277.3 [10.91]	245.7 [9.67]	93.0 [3.66]	93.0 [3.66]	393.3 [15.49]
ZF49KQE	551.5 [21.7]	519.5 [20.45]	295.0 [11.61]	263.6 [10.37]	92.6 [3.64]	92.6 [3.64]	441.0 [16.18]

### Notes:

- (1) All tolerances  $\pm 1.5\text{mm}$  [0.06in] unless otherwise specified
- (2) Due to accumulated assembly tolerances, the listed components may vary from the mounting holes. All fittings:  $\pm 3.0\text{mm}$  [0.12in]
- (3) Tube ends must be plugged
- (4) Rotalock fittings are shown
- (5) All units are in mm[inch]

# Dimensional drawings

## ZFI50KQE - ZFI68KQE (BOM 564) Rotalock connection

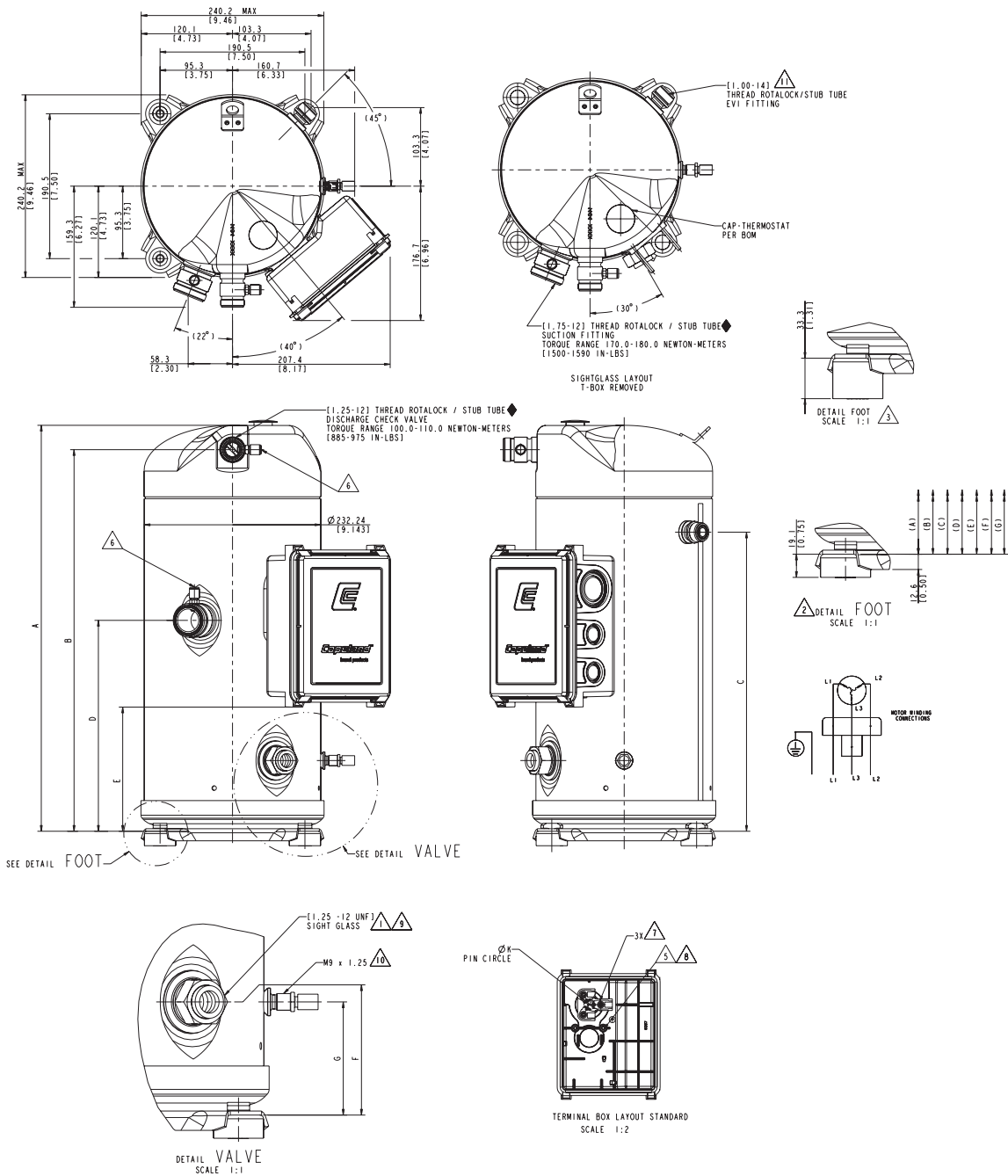

Model number	mm[in]							ØK
	A	B	C	D	E	F	G	
ZFI50KQE	533.6 [21.01]	501.8 [19.76]	393.3 [15.48]	277.3 [10.92]"	163.3 [6.43]"	93.0 [3.66]	93.0 [3.66]	17.45 [0.687]
ZFI59KQE	533.6 [21.01]	501.8 [19.76]	393.3 [15.48]	277.3 [10.92]"	163.3 [6.43]"	93.0 [3.66]	93.0 [3.66]	17.45 [0.687]
ZFI68KQE	551.5 [21.71]	519.5 [20.45]	411.0 [16.18]	295.0 [11.61]"	163.3 [6.43]"	92.6 [3.64]	92.6 [3.64]	20.70 [0.815]

### Notes:

- (1) All tolerances  $\pm 1.5\text{mm}$  [0.06in] unless otherwise specified
- (2) Due to accumulated assembly tolerances, the listed components may vary from the mounting holes. All fittings:  $\pm 3.0\text{mm}$  [0.12in]
- (3) Tube ends must be plugged
- (4) Rotalock fittings are shown
- (5) All units are in mm[inch]

# Dimensional drawings

## ZF13KQE – ZF28KQE (BOM 550) Stub tube connection

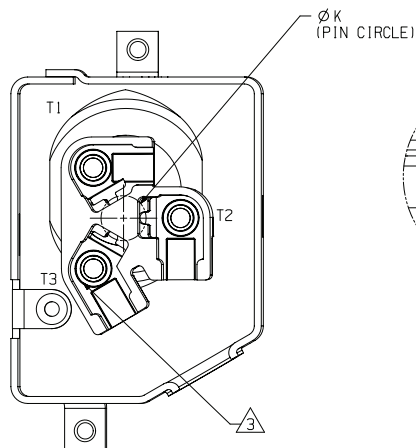
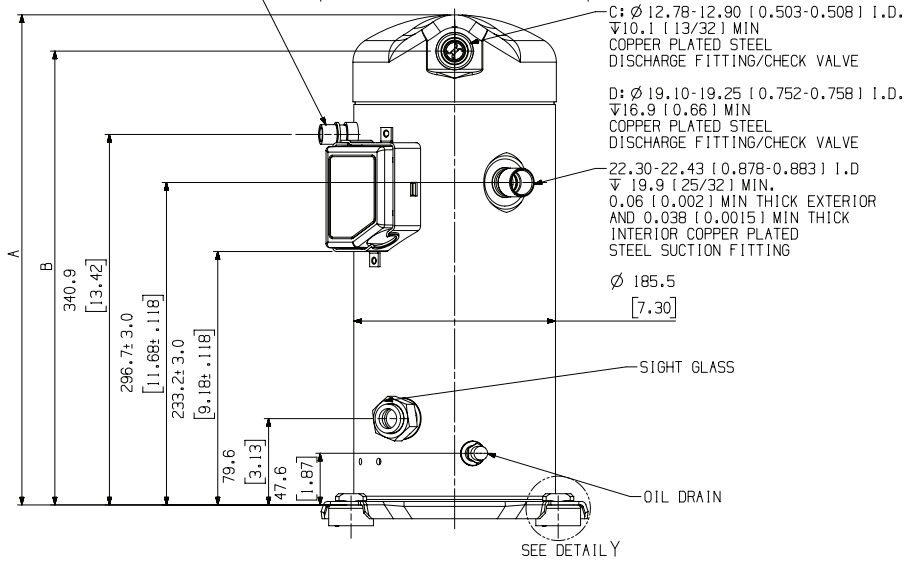
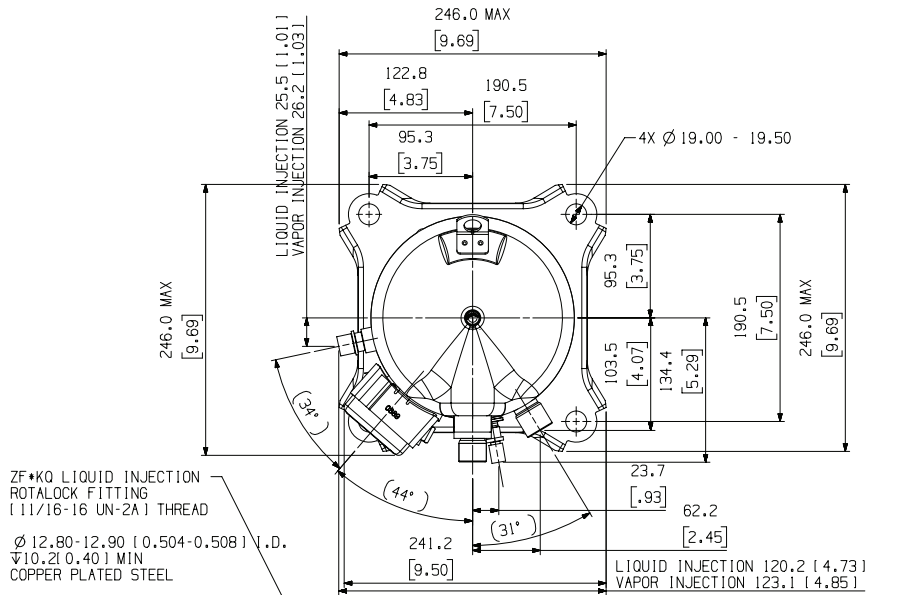

SCALE 3:2

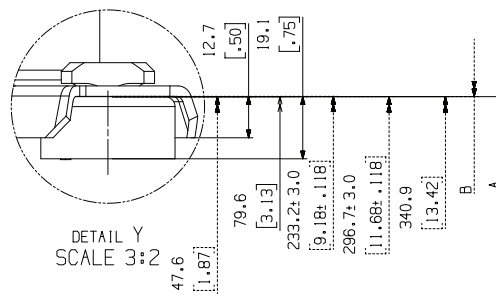

# Dimensional drawings

## ZF28KQE-TFC and ZFI39KQE-TFC (BOM 580) Stub tube connection

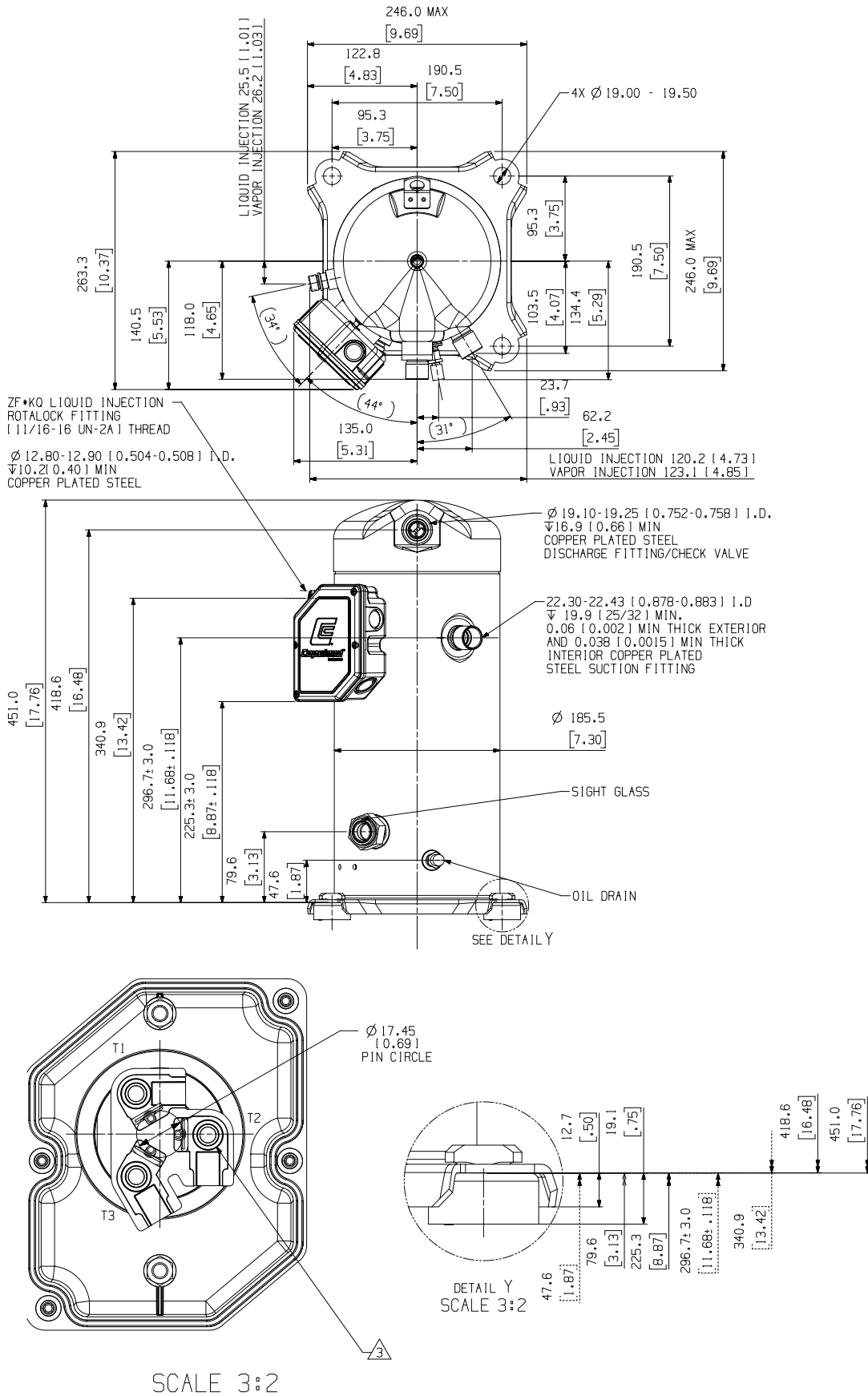

# Dimensional drawings

## ZFI20KQE – ZFI39KQE (BOM 550) Stub tube connection

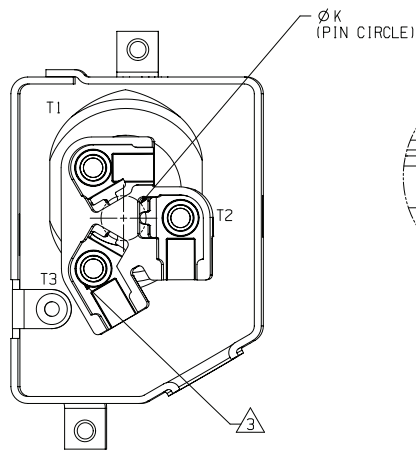
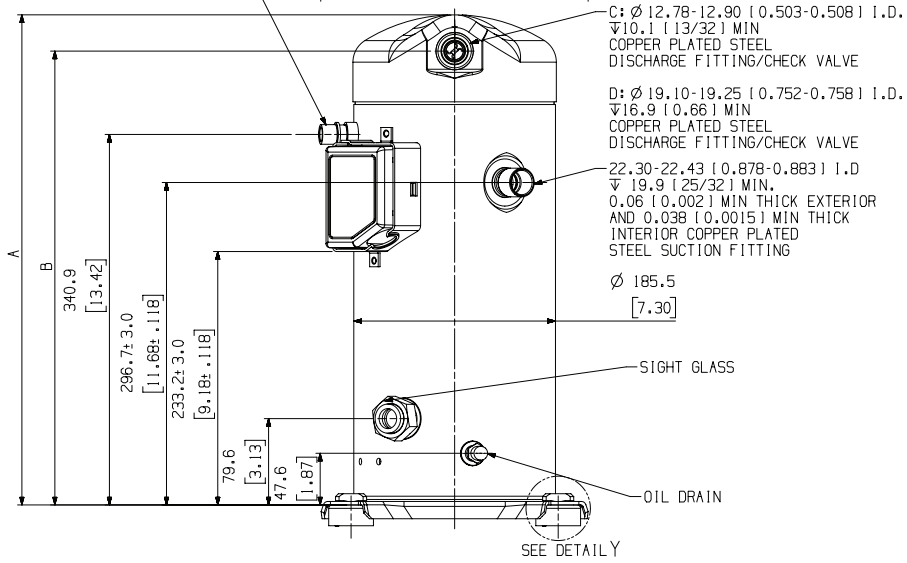
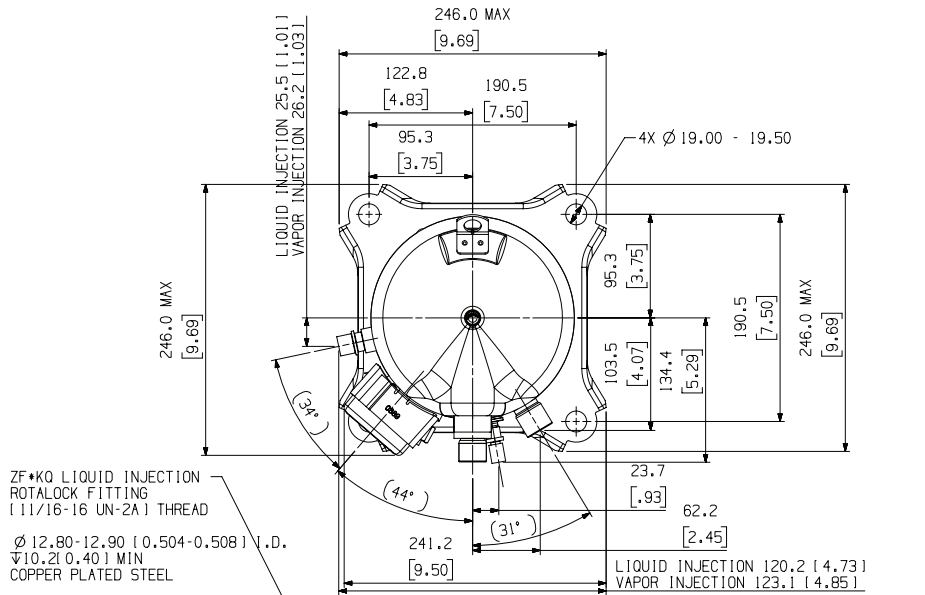

SCALE 3:2

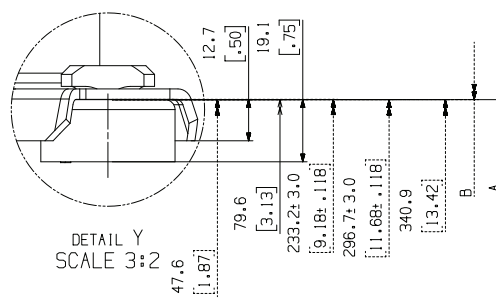

# Dimensional drawings

## ZF34KQE – ZF41KQE (BOM 569) Stub tube connection

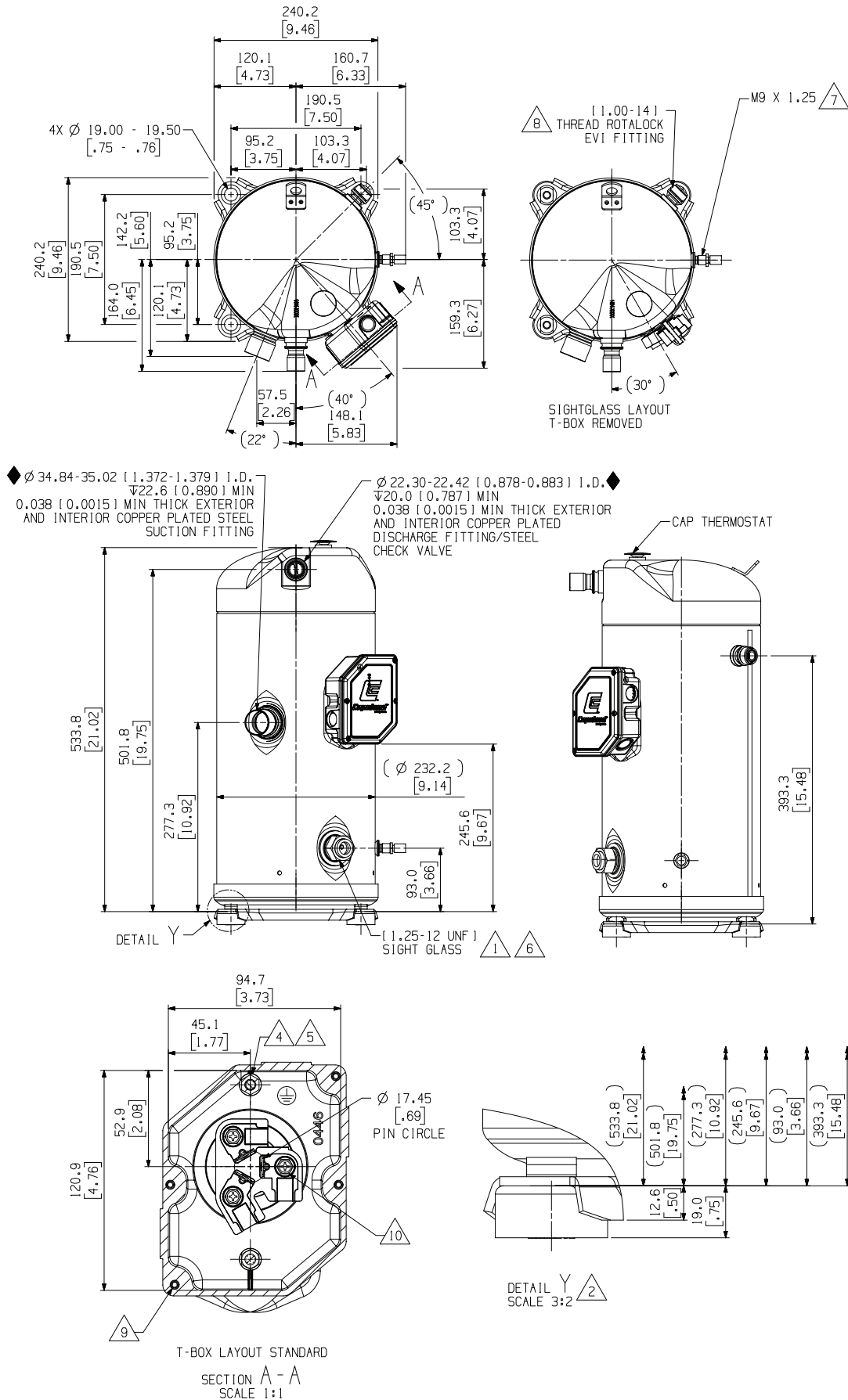





# Dimensional drawings

## ZF49KQE-TFC and ZFI68KQE-TFC (BOM569) Stub tube connection

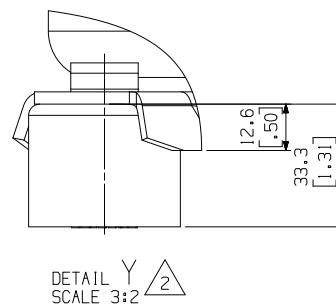
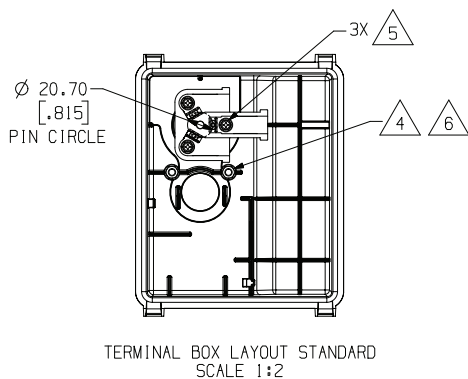
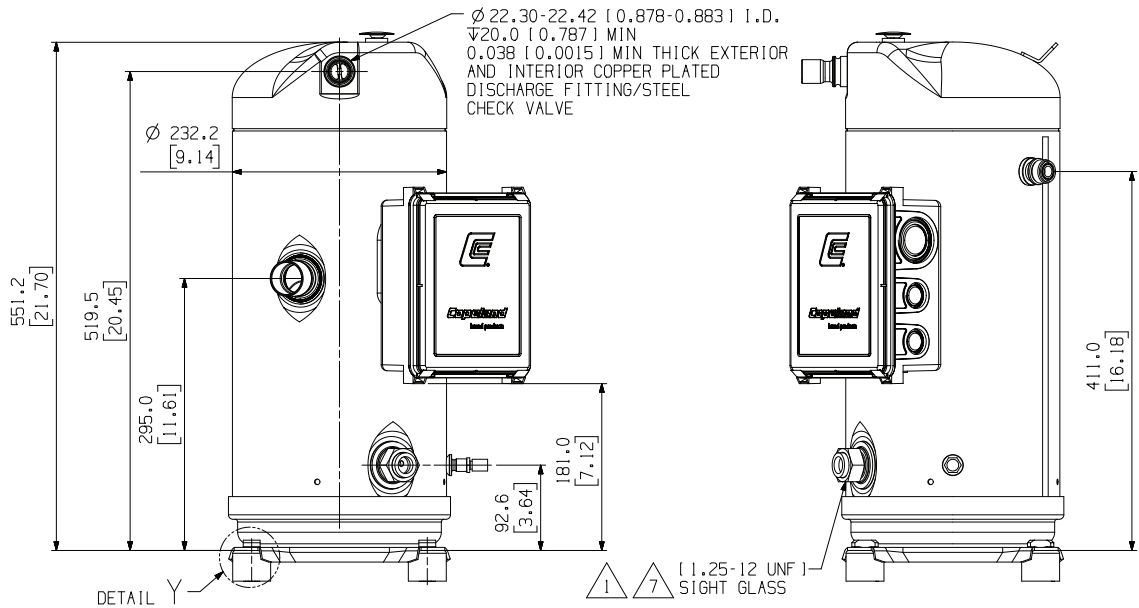
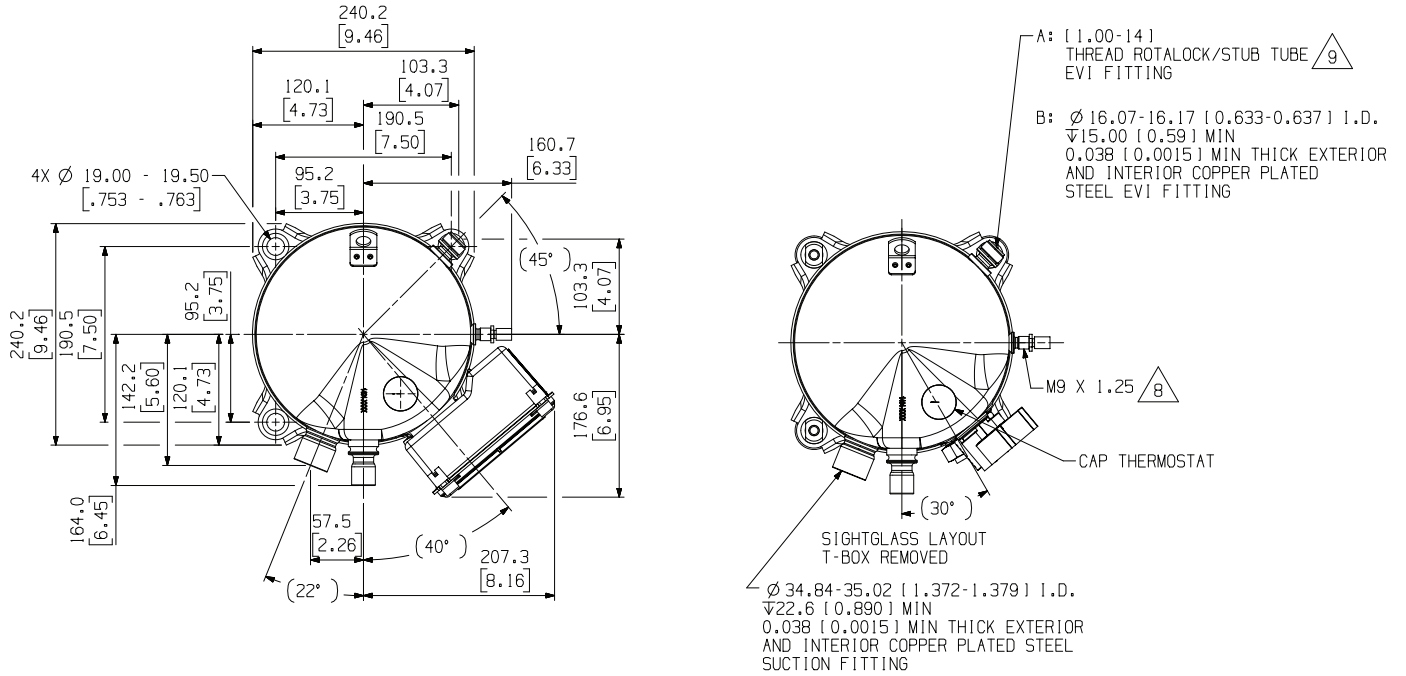

# Dimensional drawings

## ZFI50KQE – ZFI59KQE (BOM 569) Stub tube connection

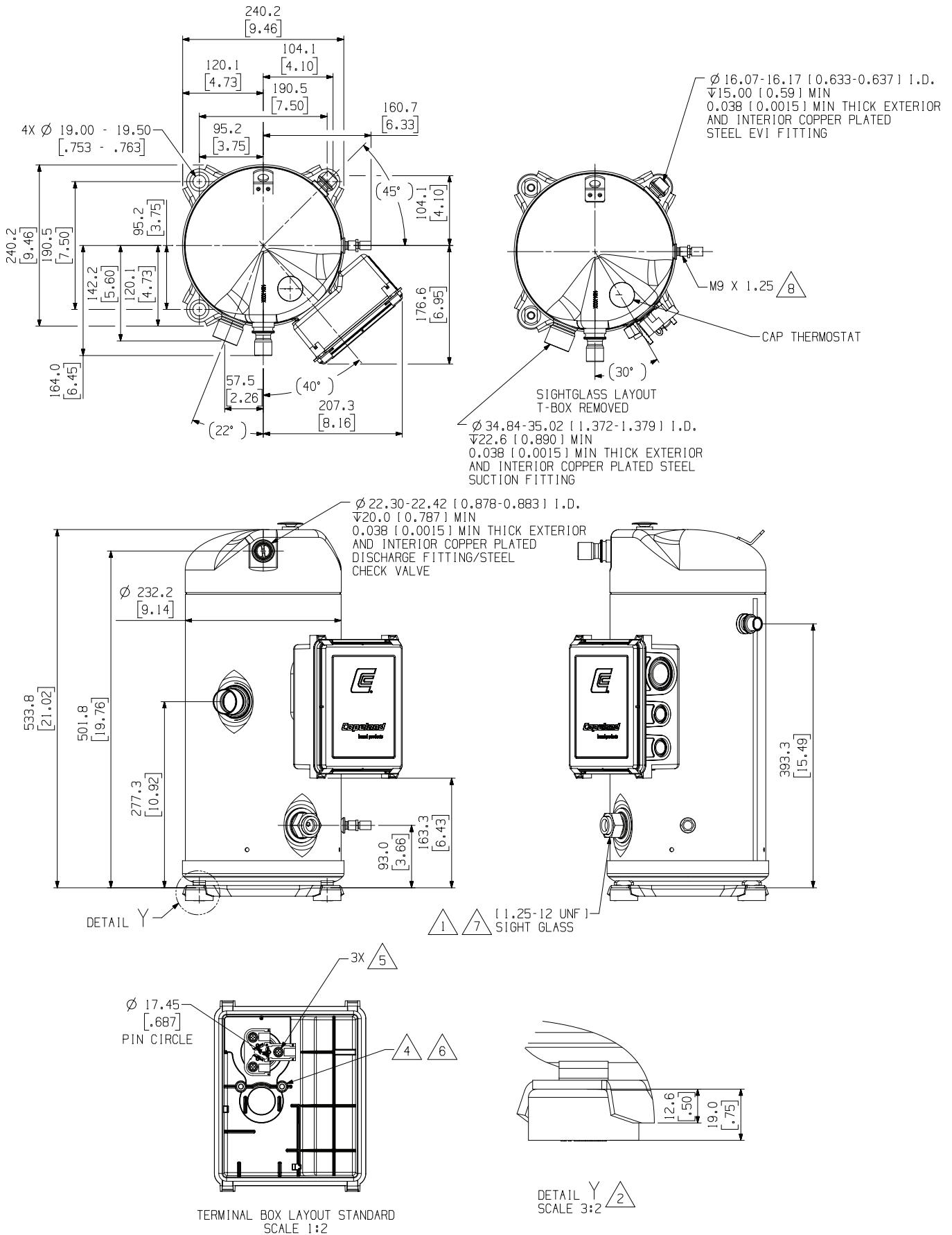

# Dimensional drawings

## ZFI68KQE-TFD/TF7 (BOM 564) Stub tube connection

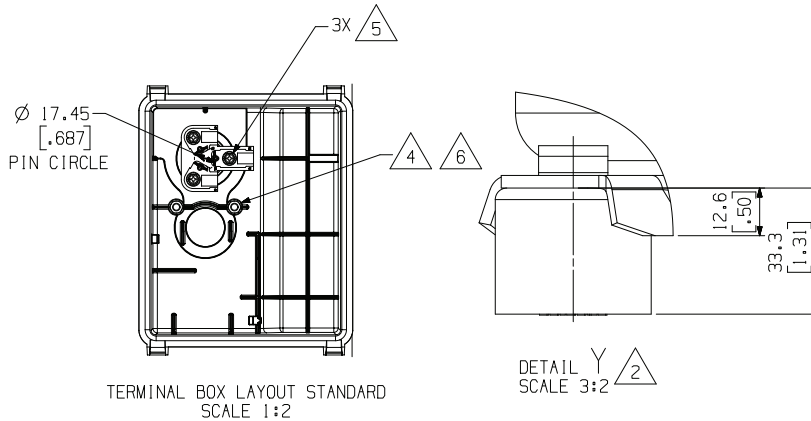
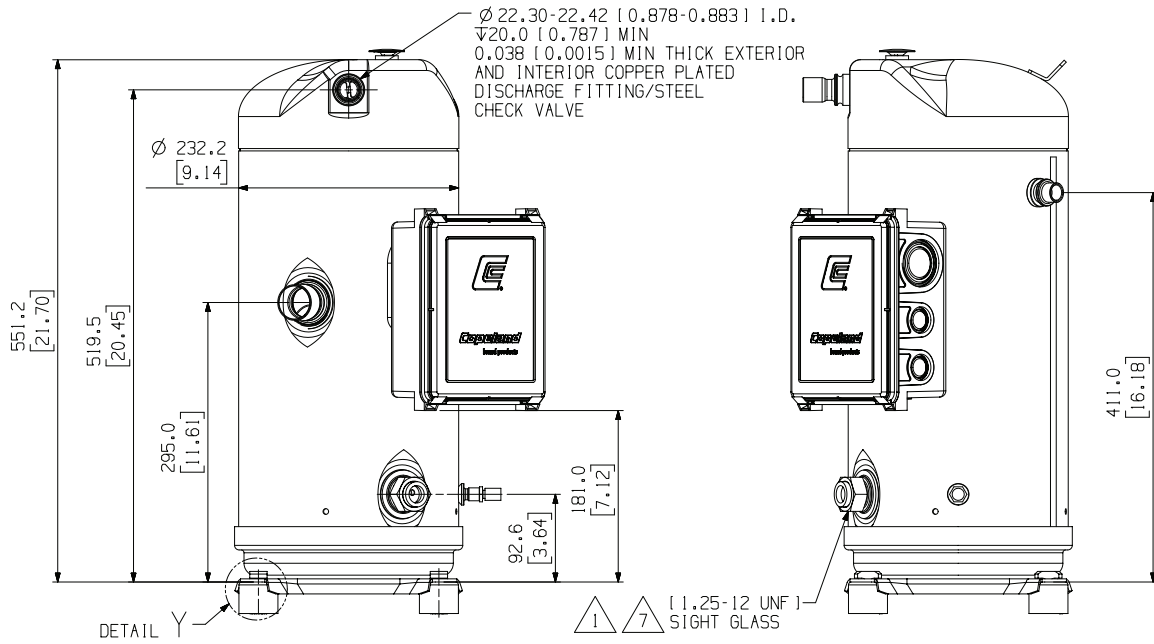
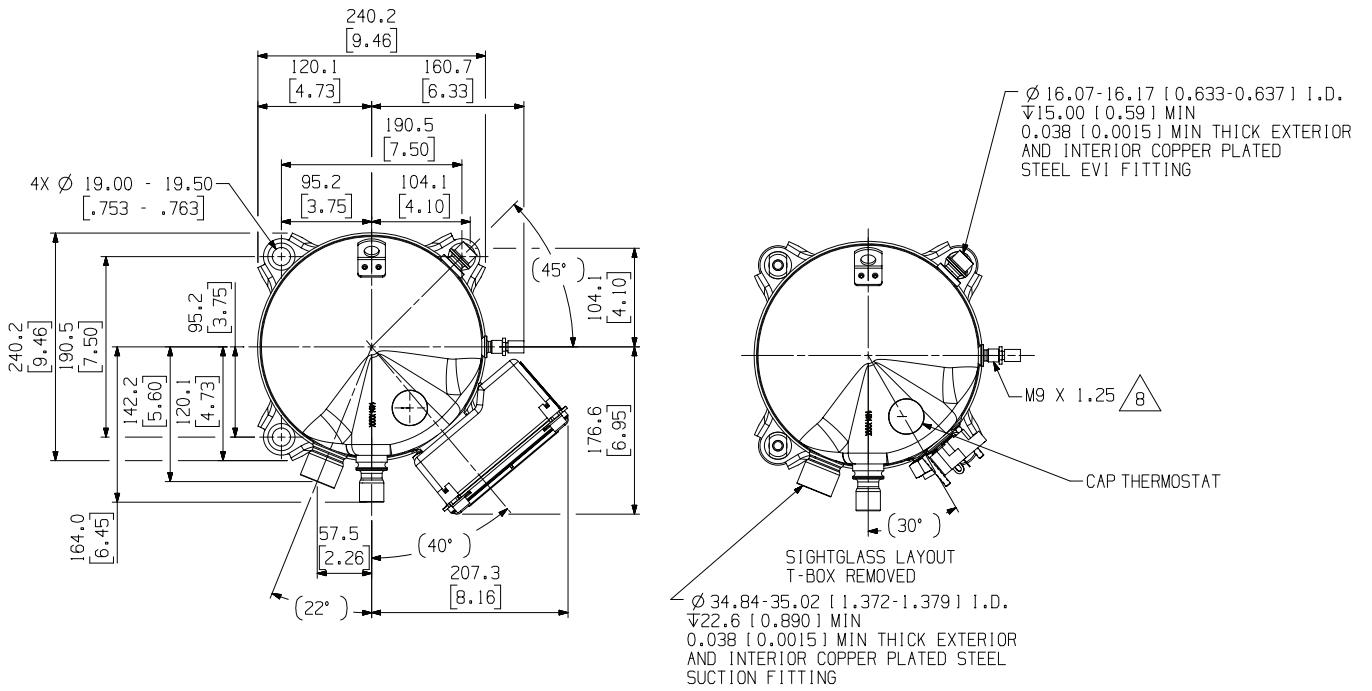

# Schematic diagram

## Liquid injection schematic

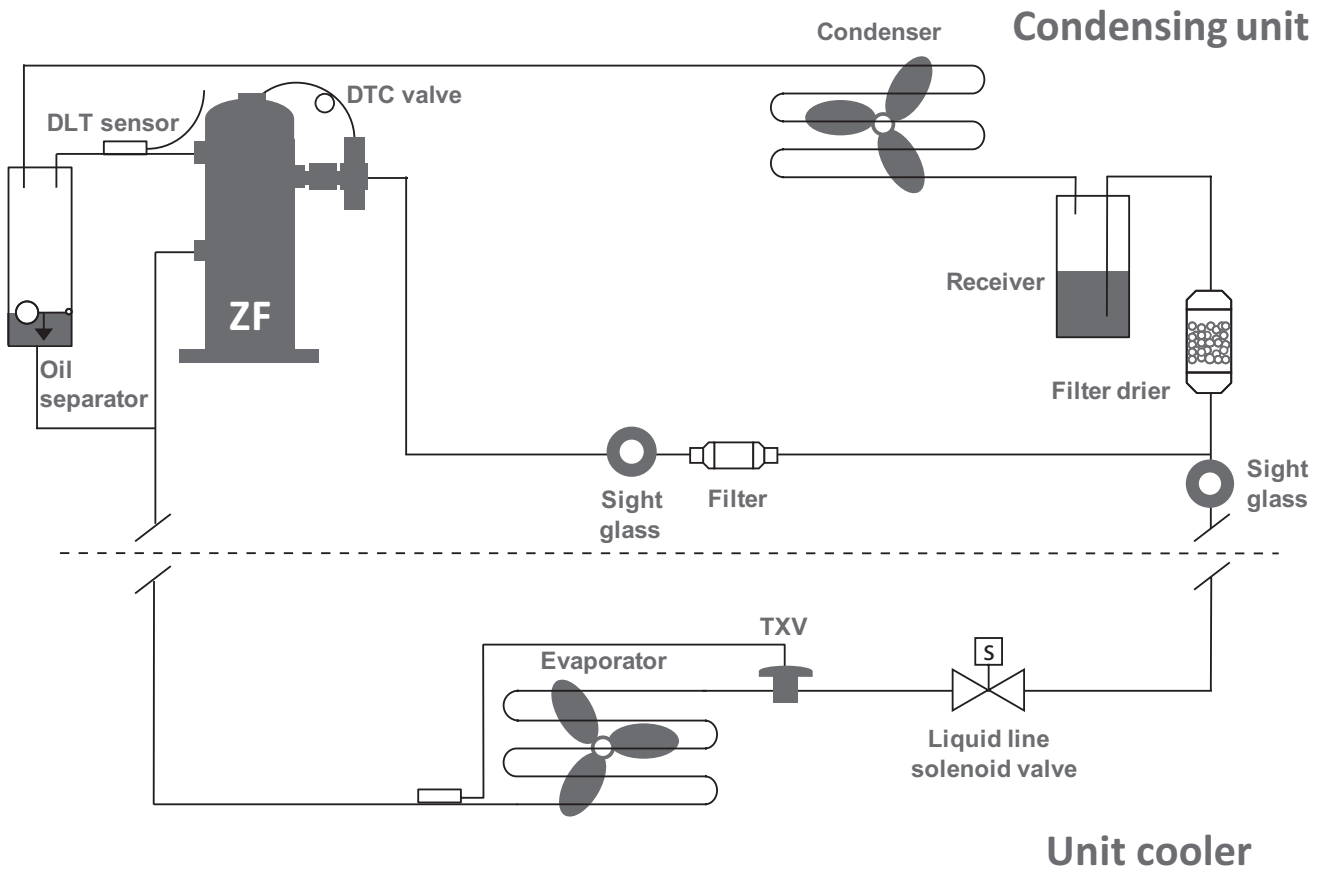

# Schematic diagram

## Vapor injection schematic

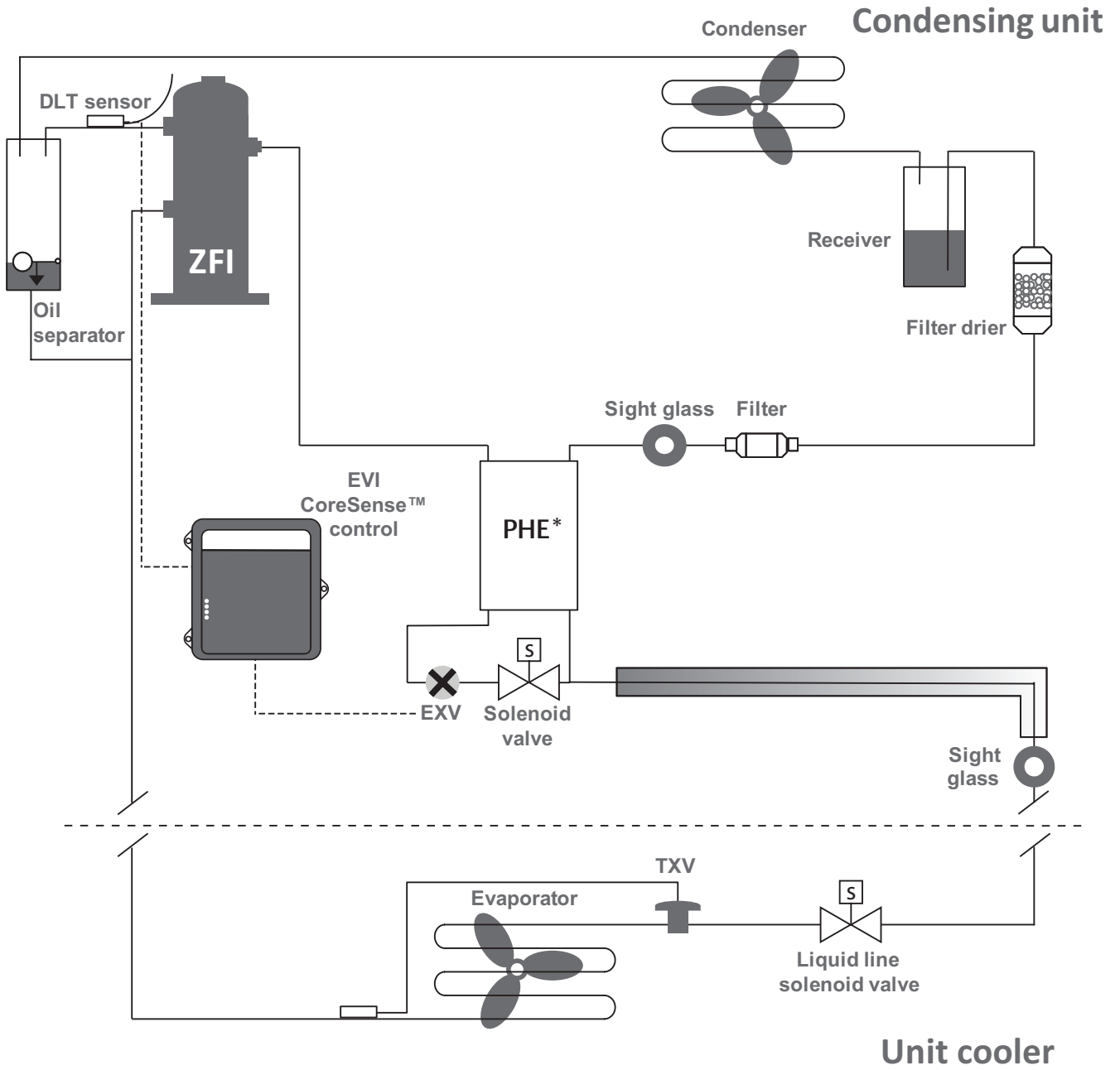

\*PHE: Plate heat exchanger



## General information

Technical data are correct at the time of printing. Updates may occur, and should you need confirmation of a specific value, please contact Emerson clearly stating the information required.

Emerson cannot be held responsible for errors in capacities, dimensions, etc., stated herein. Products, specifications and data in this literature are subject to change without notice.

The information given herein is based on data and tests which Emerson believes to be reliable and which are in accordance with today's technical knowledge. It is intended for use by persons having the appropriate technical knowledge and skill, at their own discretion and risk. Our products are designed and adapted for fixed locations. For mobile applications, failures may occur.

The suitability for this has to be assured from the plant manufacturer, which may include making appropriate tests.

### Note:

The components listed in this catalogue are not released for use with caustic, poisonous or flammable substances. Emerson cannot be held responsible for any damage caused by using these substances.

## About Emerson

Emerson (NYSE: EMR), headquartered in St. Louis, Missouri (USA), is a global technology and engineering company providing innovative solutions for customers in industrial, commercial, and residential markets. Our Emerson Automation Solutions business helps process, hybrid, and discrete manufacturers maximize production, protect personnel and the environment while optimizing their energy and operating costs. Our Emerson Commercial and Residential Solutions business helps ensure human comfort and health, protect food quality and safety, advance energy efficiency, and create sustainable infrastructure. For more information visit [Emerson.com](https://www.emerson.com).

# Contact lists

## Emerson Commercial & Residential Solutions

### Asia Pacific Headquarters

Emerson Climate Technologies  
Suite No. 2503-8, 25/F,  
Exchange Tower, 33 Wang Chiu Road,  
Kowloon Bay, Kowloon, Hong Kong  
Tel: (852) 2866 3108  
Fax: (852) 2520 6227

### Australia

Emerson Climate Technologies Australia  
Pty Ltd  
356 Chisholm Road  
Auburn NSW 2144, Australia  
Tel: (612) 9795 2800  
Fax: (612) 9738 1699

### China - Beijing

Emerson Climate Technologies  
(Suzhou) Co. Ltd  
Beijing Sales Office  
Room 1017 JianWei Building,  
66 Nan Lishi Road, XiCheng District,  
Beijing, PRC  
Tel: (8610) 5763 0488  
Fax: (8610) 5763 0499

### China - Guangzhou

Emerson Climate Technologies  
(Suzhou) Co. Ltd  
Guangzhou Sales Office  
508-509 R&F Yinglong Plaza,  
No. 76 Huangpu Road West,  
Guangzhou, PRC  
Tel: (8620) 2886 7668  
Fax: (8620) 2886 7622

### China - Shanghai

Emerson Climate Technologies  
(Suzhou) Co. Ltd  
Shanghai Sales Office  
7F, Emerson Building, 1582 Gumei  
Rd, Shanghai, PRC  
Tel: (8621) 3338 7333

### India - Mumbai

Emerson Climate Technologies (India) Ltd  
Delphi B-Wing, 601-602, 6th Floor  
Central Avenue, Hiranandani Business Park,  
Powai, Mumbai 400076  
Tel: (9122) 6786 0793  
Fax: (9122) 6662 0500

### India - Pune

Emerson Climate Technologies (India) Ltd  
Plot No. 23, Rajiv Gandhi Infotech Park,  
Phase - II, Hinjewadi,  
Pune 411 057, Maharashtra, India  
Tel: (9120) 4200 2000  
Fax: (9120) 4200 2099

### Indonesia

PT Emerson Indonesia  
BSD Taman Tekno 8  
Jl. Tekno Widya Blok H10 No 2 & 3  
Tangerang Selatan 15314  
Indonesia  
Tel: (6221) 2966 6242  
Fax: (6221) 2966 6245

### Japan

Emerson Japan Ltd  
Shin-yokohama Tosho Building  
No. 3-9-5 Shin-Yokohama, Kohoku-ku  
Yokohama 222-0033 Japan  
Tel: (8145) 475 6371  
Fax: (8145) 475 3565

### Malaysia

Emerson Electric (Malaysia) Sdn. Bhd.  
Level M2, Blk A, Menara PKNS-PJ  
Jalan Yong Shook Lin  
46050 Petaling Jaya, Selangor, Malaysia  
Tel: (603) 7949 9222  
Fax: (603) 7949 9333

### Middle East & Africa

Emerson Climate Technologies  
PO Box 26382  
Jebel Ali Free Zone – South  
Dubai, UAE  
Tel: (9714) 811 8100  
Fax: (9714) 886 5465

### Philippines

Emerson Climate Technologies  
10/F SM Cyber West Avenue, EDSA cor. West  
Avenue, Barangay Bungad, Diliman, Quezon  
City 1105 Philippines  
Tel: (632) 689 7200

### Saudi Arabia

Emerson Arabia Inc.  
P.O Box 34332 – 3620 Building 7874  
Unit 1, 67th street 2nd Industrial City  
Dammam, Saudi Arabia  
Toll Free: 8008443426  
Tel: + 966 3 8147560  
Fax: + 966 3 8147570

### South Korea

Emerson Electric Korea Ltd.  
3F POBA Gangnam Tower  
343, Hakdong-ro, Gangnam-gu,  
Seoul 135-820, Republic of Korea  
Tel: (822) 3483 1500  
Fax: (822) 592 7883

### Taiwan

Emerson Electric (Taiwan) Co. Ltd  
3F No. 122 Lane 235,  
Pao Chiau Rd., XinDian Dist.,  
New Taipei City 23145, Taiwan ( R.O.C.)  
Tel: (8862) 8912 1360  
Fax: (8862) 8912 1890

### Thailand - Bangkok

Emerson Electric (Thailand) Ltd  
34th Floor, Interlink Tower,  
1858/133, Bangna Trad,  
Bangkok 10260, Thailand  
Tel: (662) 716 4700  
Fax: (662) 751 4241

### United Arab Emirates

Emerson Climate Technologies FZE  
Jebel Ali Free Zone  
PO Box 26382  
Dubai UAE  
Toll Free: 8004413428  
Tel: + 971 4 8118100  
Fax: + 971 4 8865465

### Vietnam

Emerson Commercial & Residential Solutions  
Level 6, Melinh Point Tower, 2 Ngo Due Ke,  
District 1, Ho Chi Minh City  
Vietnam  
Tel: (84) 908 009 189

Scan to visit:



Emerson Asia

## Emerson.com

Asia 02 A01 03 - R00 Issued 5/2017 - GSCAA035

Emerson is a trademark of Emerson Electric Co. or one of its affiliated companies. ©2018 Emerson Electric Co. All rights reserved.

