

# Fisher™ HP and HPA Control Valves



# Table of Contents

## Section 1: Introduction

1.1	Scope of the Manual .....	2
1.2	Description .....	4
1.3	Specifications .....	4
1.4	Educational Services .....	4

## Section 2: Installation

2.1	Lifting Valve Assembly .....	11
-----	------------------------------	----

## Section 3: Maintenance

3.1	Packing Lubrication .....	14
3.2	Packing Maintenance .....	15
3.3	Trim Removal .....	24
3.4	Valve Plug Maintenance .....	26
3.5	Lapping Seats .....	27
3.6	Trim Replacement .....	30
3.7	Retrofit: Installing C-seal Trim .....	38
3.8	Replacement of Installed C-seal Trim .....	42
3.9	Replacement of Installed Bore Seal Trim .....	46

## Section 4: Parts Ordering .....

50

## Section 5: Parts Kits .....

50

## Section 6: Parts List .....

72

# Section 1: Introduction

## 1.1 Scope of the Manual

This instruction manual includes installation, maintenance and parts information for NPS 1 through 24 HP valves with CL900 and CL1500 ratings; NPS 1 through 14 HP with CL2500 ratings; NPS 1 through 8 HPA valves with CL900 and CL1500 ratings; NPS 1, 2, 6, 8 and 12 HPA valves with CL2500 ratings; NPS 8 through 12 HPD and HPT valves with CL3200 ratings. Refer to separate manuals for instructions covering the actuator, positioner and accessories.

### WARNING



**Do not install, operate or maintain HP series valves without being fully trained and qualified in valve, actuator and accessory installation, operation and maintenance. To avoid personal injury or property damage, it is important to carefully read, understand and follow all the contents of this manual, including all safety cautions and warnings. If you have any questions about these instructions, contact your [Emerson sales office](#) before proceeding. Unless otherwise noted, all NACE references are to NACE MR0175-2002 and MR0103.**

**Figure 1. HP Valve with 667 Actuator and FIELDVUE™ DVC6200 Digital Valve Controller**



X0183-1

**Table 1. Specifications**

End Connection Styles and Ratings <sup>(1,2,3,4)</sup>	Shutoff Classifications
<p>Flanged: Consistent with CL900, CL1500 and CL2500 per ASME B16.34</p> <p>Socket Welding: Consistent with CL900, CL1500 and CL2500 per ASME B16.34</p> <p>Buttwelding: Consistent with CL900, CL1500 CL2500 and intermediate rating CL3200 per ASME B16.34</p> <p>Also see Table 2</p>	<p>See Table 3</p> <p>C-seal trim: High-temperature, Class V</p> <p>Bore seal trim: High-temperature, Class V</p> <p>TSO (Tight Shutoff) trim: See Tables 4 and 5</p>
Flow Characteristic	Flow Direction
<p>Standard Cage: ■ Equal percentage, ■ Modified equal percentage or ■ Linear</p> <p>Standard Cage with Micro-Form Valve Plug: (HPS and HPAS only): ■ Equal percentage or ■ Modified equal percentage</p> <p>Standard Cage with Micro-Flute Valve Plug: (HPS and HPAS only): ■ Equal percentage</p> <p>Standard Cage with Micro-Flat Valve Plug: (HPAS only): ■ Linear</p> <p>Cavitrol™ III, Whisper Trim™ III or WhisperFlo™ Cage: ■ Linear</p> <p>Special cages: Special characterized flow cages are available. Consult your local <a href="#">Emerson sales office</a>.</p>	<p>Standard Cage</p> <ul style="list-style-type: none"> <li>■ HPD and HPAD: Normally flow down<sup>(6)</sup></li> <li>■ HPS and HPAS: Normally flow up<sup>(5)</sup></li> <li>■ HPAS Micro-Flat: Flow down</li> <li>■ HPT and HPAT: Normally flow down<sup>(6)</sup></li> <li>■ HPS and HPAS Micro-Form: Flow up only</li> </ul> <p>Cavitrol III Cage: Flow down</p> <p>Whisper Trim III or WhisperFlo Cage: Flow up</p>
Approximate Weights (valve body and bonnet assemblies)	Additional Specifications
<p>See Table 2</p>	<p>For specifications such as materials, valve plug travels and port, yoke boss and stem diameters, see the Parts List section.</p>
<ol style="list-style-type: none"> <li>1. EN (or other) ratings and end connections can usually be supplied; consult your Emerson sales office.</li> <li>2. CL900 and CL1500 globe valves are identical for NPS 1 and 2 valves. CL900 and CL1500 globe valves for NPS 3, 4, 6, 8, 10 and 12 valves, however, are not identical.</li> <li>3. The centerline-to-face dimension for CL2500 NPS 1 and 2 HPA valves does not conform to ANSI/ISA S75.12.</li> <li>4. The pressure or temperature limits in this manual and any applicable standard limitations should not be exceeded.</li> <li>5. HPS and HPAS valves may be used flow down for on-off service only or where further limited by trim design. HPAS valves may be used flow down for erosive service.</li> <li>6. NPS 16, 18, 20 and 24 valves for flow down only.</li> </ol>	

## 1.2 Description

HP Series high-pressure globe and angle valves (Figure 1) have metal seats, cage guiding, quick change trim and push-down-to-close valve plug action. HPD, HPAD, HPT and HPAT valves use balanced valve plugs. HPS and HPAS valves use an unbalanced valve plug. To provide a seal between the cage and a balanced valve plug, the HPD and HPAD valves use piston rings; the HPT and HPAT valves use a pressure-assisted seal ring. A Whisper Trim or WhisperFlo cage can be used with an HPD, HPAD, HPS, HPAS, HPT or HPAT valve plug. A Cavitrol III cage can be used with an HPS, HPAS, HPT or HPAT valve plug.

C-seal or bore seal trims are available for HPD and for HPAD valves.

With C-seal trim and bore seal trim, a balanced valve can achieve high-temperature, Class V shutoff. Because the seal is formed from metal (N07718 nickel alloy) rather than an elastomer, a valve equipped with the C-seal trim or bore seal trim can be applied in processes with a fluid temperature of up to 593 °C / 1100 °F, provided other material limits are not exceeded.

HP Series globe valves are available in short (short) and or long (long) face-to-face designs depending on size and pressure class.

## 1.3 Specifications

Specifications for the HP Series valves are shown in Tables 1 through 7.

## 1.4 Educational Services

Emerson Educational Services  
 Phone: -800-338-8158  
 E-mail: [education@emerson.com](mailto:education@emerson.com)  
[emerson.com/mytraining](http://emerson.com/mytraining)

**Table 2. Approximate Weights (Valve and Bonnet Assemblies)**

VALVE TYPE	VALVE SIZE, NPS	PRESSURE RATING	kg		lbs	
			Flg	SWE, BWE	Flg	SWE, BWE
Globe Valves	1	CL900 and 1500	42	38	93	85
		CL2500	45	34	100	76
	1-1/2 x 2	CL2500	---	34	---	76
	2	CL900 and 1500	72	52	158	115
		CL2500	104	74	229	164

- continued -

**Table 2. Approximate Weights (Valve and Bonnet Assemblies) (continued)**

VALVE TYPE	VALVE SIZE, NPS	PRESSURE RATING	kg		lbs	
			Flg	SWE, BWE	Flg	SWE, BWE
Globe Valves	3	CL900	125	---	276	---
		CL1500	129	97	284	213
		CL2500	228	163	502	358
	4 (long) <sup>(2)</sup>	CL900	230	---	507	---
		CL1500	249	201	548	444
	4 (short) <sup>(2)</sup>	CL900	167	136	368	---
		CL1500	194	162	428	444
		CL2500	321	206	708	444
	6 (long) <sup>(2)</sup>	CL900	511	---	1127	---
		CL1500	557	455	1228	1003
	6 (short) <sup>(2)</sup>	CL900	317	227	699	500
		CL1500	575	269	1268	593
		CL2500	757	481	1669	1060
	8	CL900	720	510	1587	1124
		CL1500	930	640	2050	1411
		CL2500	1630	1050	3594	2315
		CL3200	---	1460	---	3219
	10	CL900	1030	750	2271	1653
		CL1500	1490	1010	3285	2227
		CL2500	2560	1550	5644	3417
		CL3200	---	2200	---	4850
	12	CL900	1340	940	2954	2072
		CL1500	1950	1250	4299	2756
		CL2500	3380	2000	7452	4409
CL3200		---	2950	---	6504	
14	CL2500	---	2297	---	5064	
16	CL900	3343	---	7371	---	
	CL1500	5039	---	11109	---	
18	CL900	4387	---	9671	---	
	CL1500	6168	---	13598	---	
20	CL900	7942	---	17509	---	
	CL1500	11396	---	25123	---	
24	CL900	9757	---	21510	---	
	CL1500	13644	---	30080	---	

- continued -

**Table 2. Approximate Weights (Valve and Bonnet Assemblies) (continued)**

VALVE TYPE	VALVE SIZE, NPS	PRESSURE RATING	kg		lbs	
			Flg	SWE, BWE	Flg	SWE, BWE
Angle Valves	1	CL900 and 1500	40	36	88	80
		CL2500	---	72 <sup>(1)</sup>	---	160 <sup>(1)</sup>
	2	CL900 and 1500	69	50	153	110
		CL2500	---	109 <sup>(1)</sup>	---	240 <sup>(1)</sup>
	3	CL1500	123	78	272	173
	4	CL1500	181	117	399	258
	6	CL1500	357	202	788	445
		CL2500	658	325	1451	716
	8	CL1500	648	405	1428	893
		CL2500	971	663	2141	1462
12	CL2500	2471	1660	5448	3660	

1. Only SWE is available for CL2500.  
 2. (Long) indicates industry standard long face-to-face. (Short) indicates industry standard short face-to-face.

**Table 3. Shutoff Classifications per ANSI/FCI 70-2 and IEC 60534-4**

Valve Design	Port Diameter, mm / in.		ANSI/FCI and IEC Leakage Class		
HPD, HPAD	57.15 / 2.25 and smaller		II		
	58.7 / 2.3125 to 92.1 / 3.625		II - Standard		
			III - Optional		
	105.9 / 4.17 and larger		III - Standard		
			IV - Optional		
317.5 / 12.5 to 489 / 19.25		IV - Standard			
	Valve Size, NPS		Port Diameter, mm / in.	Cage Style	ANSI/FCI and IEC Leakage Class
	HPD	HPAD			
HPD, HPAD with C-seal trim	3	4	73 / 2.875	Eq. %, Mod Eq. %, Linear (std. cage), Linear (Whisper III, A1, B1)	V - Standard to 593 °C / 1100 °F (for port diameters from 73 mm / 2.875 in. through 136.5 mm / 5.375 in. with optional C-seal trim)  IV - Optional (for port diameters 73 mm / 2.875 in. through 136.5 mm / 5.375 in.)
	4	6	73 / 2.875	Linear (Whisper III, D3)	
			92.1 / 3.625	Eq. %, Mod. Eq. %, Linear (std. cage), Linear (Whisper III, A1, B3, C3)	
	6	8	111.1 / 4.375	Linear (Whisper III, D3)	
136.5 / 5.375			Eq. %, Mod. Eq. %, Linear (std. cage), Linear (Whisper III, A1, B3, C3)		

- continued -

**Table 3. Shutoff Classifications per ANSI/FCI 70-2 and IEC 60534-4 (continued)**

	Valve Size, NPS		Port Diameter, mm / in.	Cage Style	ANSI/FCI and IEC Leakage Class
	HPD	HPAD			
HPD <sup>(2)</sup> , HPAD <sup>(2)</sup> with Bore-seal trim	8	---	139.7 / 5.5	Eq. %, Linear (std. cage), Whisper III, Cavitrol III	V - Standard to 593 °C / 1100 °F (for port diameters from 139.7mm/5.5in. through 215.9 mm / 8.5 in. with optional Bore-seal trim)
			152.4 / 6		
	10	---	165.1 / 6.5		
			177.8 / 7		
	12	12	165.1 / 6.5		
			190.5 / 7.5		
203.2 / 8					
14	---	215.9 / 8.5			
		215.9 / 8.5			
HPS, HPAS, HPT, HPAT			All	Cavitrol III and Micro-Flat	V - Standard
				Micro-Form, Micro-Flute, Eq. %, Mod Eq. %, Linear, Whisper III	IV - Standard V - Optional
HPS and HPT with TSO (Tight Shutoff trim)			See Tables 4 and 5	See Tables 4 and 5	TSO - Optional TSO is not an ANSI/FCI or IEC leakage class. Valves with TSO trim are factory tested to a more stringent Fisher test requirement of no leakage at time of shipment. Test medium is water. Specify service ΔP when ordering. Test procedure is ANSI/FCI Class V test procedure B.
HPT and HPAT with PEEK <sup>(1)</sup> Anti-Extrusion Rings			47.6 / 1.875 to 489 / 19.25	All	V - Standard (to 316 °C / 600 °F) IV - Optional (47.6 mm / 1.875 in. through 489 mm / 19.25 in. ports)
1. PEEK (PolyEtherEtherKetone), required for all boiler feedwater applications. 2. Trims 263, 2635, 264, 2645, 265 and 2655 are not available in bore-seal.					

**Table 4. TSO (Tight Shutoff) Leakage Class per ANSI/FCI 70-2 and IEC 60534-4<sup>(1)</sup>**

Leakage Class	Maximum Leakage	Test Medium	Test Pressure	Leakage Class
TSO (Tight Shutoff)	Valves with TSO trim are factory tested to a more stringent Emerson test requirement of no leakage at time of shipment.	Water	Service ΔP <sup>(2)</sup>	V
1. Not available for NPS 8 to 12 HPD and HPT. 2. Specify service ΔP when ordering.				

**Table 5. TSO Shutoff Availability<sup>(1)</sup>**

VALVE DESIGN	CONSTRUCTION	LEAKAGE CLASS
HPS, HPT	Std or Cavtrol III trim. Replaceable, protected soft seat	TSO - Standard
1. Not available for NPS 8 to 12 HPD and HPT.		

**Table 6. Recommended Torque for Packing Flange Nuts (Non Live-loaded Graphite Packing)<sup>(1)</sup>**

STEM DIAMETER		VALVE BODY RATING <sup>(2)</sup>	TORQUE			
mm	in.		N•m		lbf•ft	
			Min	Max	Min	Max
12.7	1/2	CL900	12	18	9	13
12.7	1/2	CL1500	15	22	11	16
12.7	1/2	CL2500	18	24	13	18
19.1	3/4	CL900	27	41	20	30
19.1	3/4	CL1500	34	50	25	37
19.1	3/4	CL2500	41	61	30	45
25.4	1	CL900	42	62	31	46
25.4	1	CL1500	52	77	38	57
25.4	1	CL2500	61	91	45	67
31.8	1-1/4	CL900	56	83	41	61
31.8	1-1/4	CL1500	68	102	50	75
31.8	1-1/4	CL2500	81	122	60	90
31.8	1-1/4	CL3200	81	122	60	90
50.8	2	CL900	80	119	59	88
50.8	2	CL1500	98	146	72	108
50.8	2	CL2500	115	170	85	125
50.8	2	CL3200	115	170	85	125
1. Lubricate with anti-seize lubricant.						
2. For intermediate class ratings, use the same torque as the next lower standard class.						

**Table 7. Torque for Body-to-Bonnet Bolting Using Anti-Seize Lubricant<sup>(1)</sup>**

STUD SIZE	TORQUE	
	N•m	lbf•ft
	B7, B16, B8M2, BD, S20910, N07718 and 660 Studs	B7, B16, B8M2, BD, S20910, N07718 and 660 Studs
3/4	260	190
7/8	370	275
1-1/8	710	525
1-1/4	940	695
1-3/8	1270	935
1-1/2	1650	1220
1-5/8	2130	1570
1-3/4	2670	1970
1-7/8	3310	2440
2	4030	2970
2-1/4	5780	4260
2-1/2	7990	5890

1. For other lubricants or bolting materials, contact your [Emerson sales office](#) for torques.

## Section 2: Installation

### **WARNING**

Always wear protective gloves, clothing and eyewear when performing any installation operations to avoid personal injury.

Personal injury or equipment damage caused by sudden release of pressure may result if the valve assembly is installed where service conditions could exceed the limits given in Table 1 or on the appropriate nameplates. To avoid such injury or damage, provide a relief valve for over-pressure protection as required by government or accepted industry codes and good engineering practices.

Check with your process or safety engineer for any additional measures that must be taken to protect against process media.

If installing into an existing application, also refer to the **WARNING** at the beginning of the Maintenance section in this instruction manual.

### **WARNING**

Some bonnet flanges have a tapped hole that was used to handle the bonnet during manufacture. Do not use this tapped hole to lift the valve assembly or personal injury may result.

**⚠ WARNING**

When ordered, the valve configuration and construction materials were selected to meet particular pressure, temperature, pressure drop and controlled fluid conditions indicated when the valve was ordered. Responsibility for the safety of process media and compatibility of valve materials with process media rests solely with the purchaser and end-user. Because some body/trim material combinations are limited in their pressure drop and temperature ranges, do not apply any other conditions to the valve without first contacting your [Emerson sales office](#).

**NOTICE**

To avoid product damage, inspect the valve before installation for any damage or any foreign material that may have collected in the valve body. Also remove any pipe scale, welding slag or other foreign material from the pipeline.

1. Before installing the valve, inspect it to ensure that the valve body cavity is free of foreign material.
2. Clean out all pipelines to remove scale, welding slag, and other foreign materials before installing the valve.

**NOTE**

If the valve body being installed has small internal flow passages, such as with Whisper Trim III, WhisperFlo or Cavitrol III cages, consideration should be given to installing an upstream strainer to prevent the lodging of particles in these passages. This is especially important if the pipeline cannot be thoroughly cleaned or if the flowing medium is not clean.

3. Flow through the valve must be in the direction indicated by the flow arrow, which is stamped on or attached to the valve body.

**NOTE**

NPS 8 to 14 CL900, CL1500, CL2500 and CL3200 HPD and HPT valves contain a flow vane in the lower flow passage. This is critical to the proper function of the valve, and is not a defect.

**NOTICE**

Depending on valve body materials used, post-weld heat treating might be needed. Post-weld heat treatment can damage internal elastomeric, plastic and metal parts. Shrink-fit pieces and threaded connections might also loosen. In general, if post-weld heat treating is needed, remove all trim parts. Contact your [Emerson sales office](#) for additional information.

4. Use accepted piping and welding practices when installing the valve in the pipeline. For flanged valve bodies, use a suitable gasket between the body and pipeline flanges.
5. Install a three-valve bypass around the valve if continuous operation is required during maintenance.
6. If the actuator and valve body are shipped separately, refer to the actuator mounting procedure in the appropriate actuator instruction manual.
7. If the valve body was shipped without packing installed in the packing box, install the packing before putting the valve body into service. Refer to instructions given in the Packing Maintenance procedure.

### **WARNING**

**Personal injury could result from packing leakage. Valve packing was tightened before shipment; however, the packing might require some readjustment to meet specific service conditions.**

Valves with ENVIRO-SEAL™ live-loaded packing or HIGH-SEAL ULF live-loaded packing will not require this initial re-adjustment. See the instruction manuals titled ENVIRO-SEAL Packing System for Sliding-Stem Valves (D101642X012) or HIGH-SEAL ULF Live-Loaded Packing System (D101453X012) (as appropriate) for packing instructions. If you wish to convert your present packing arrangement to ENVIRO-SEAL packing, refer to the retrofit kits listed in the parts kit sub-section near the end of this manual.

## 2.1 Lifting Valve Assembly

### **WARNING**

**Failure to follow these lifting guidelines and accepted lifting and rigging practices could result in property damage and personal injury or death.**

**All lifting and rigging must be completed in accordance with federal/national/provincial, state and local regulations and applicable lifting and rigging equipment standards. Only personnel trained in proper lifting and rigging practices shall perform valve/actuator assembly lifting, rigging and installation. Because each lift will be unique, the method of lifting the valve assembly, the correct location for attaching and lifting the valve assembly and what the valve assembly will do when lifted shall be considered for each lift.**

**Lifting and rigging equipment used to lift, install or remove a valve assembly or component must be properly selected and sized for the weight and configuration of the valve assembly or component being lifted. The weight of the complete valve assembly, including attached accessories, must be taken in consideration for this purpose. The lifting and rigging equipment must be properly maintained and inspected for damage before each use.**

**If the valve is supplied with an actuator or handwheel, do not use the actuator or handwheel to lift the complete valve assembly. Lifting lugs attached to the actuator must not be used to lift the complete valve assembly unless clearly marked as being rated to support the complete valve assembly weight.**

**Lifting lugs or other lifting equipment attached to the valve or actuator must never be used to lift or support the weight of attached piping.**

**NOTICE**

**Care must be taken when lifting the valve/actuator assembly to ensure all accessories and tubing are not damaged in the process. Accessories and tubing may need to be removed prior to lifting to prevent damage and properly reinstalled before use. Protect valve flange faces, butt weld ends and other connection surfaces from damage during lifting.**

Remove the valve/actuator assembly from its shipping container with appropriate lifting and rigging equipment for the valve/actuator assembly weight and configuration to be lifted. The valve and bonnet assembly weight is provided in Table 2. Consult the appropriate actuator and valve accessory instruction manuals for the weight of each additional component, then determine the total weight of the complete valve assembly. The location of the valve/actuator assemblies center of gravity must be considered during lifting, installation and removal. Additional slings or other lifting equipment, such as a load leveler, may be necessary to prevent toppling of the equipment during lifting or to rotate the valve assembly into a different orientation for installation.

For HP valve constructions that include lifting lugs cast integral to the body (NPS 16 through 24), use of properly sized shackles in each lifting lug eye is required. The correct shackle pin diameter is provided in Table 8. If the valve body includes attached lifting lugs, use all the lugs provided to lift the complete valve assembly. If lifting lugs are not provided on the valve body, lift the valve assembly with lifting straps secured around the valve body flanges, valve body neck and/or bonnet neck area.

**Table 8. Fisher HP Lifting Lug Dimensions**

VALVE SIZE	CLASS	LIFTING EYE ID		SHACKLE PIN DIAMETER	
		mm	in.	mm	in.
16	900	33.78	1.33	31.75	1.25
	1500	40.38	1.59	38.10	1.50
18	900	37.08	1.46	35.05	1.38
	1500	43.94	1.73	41.40	1.63
20	900	53.84	2.12	50.80	2.00
	1500	60.70	2.39	57.15	2.25
24	900	53.84	2.12	50.80	2.00
	1500	60.70	2.39	57.15	2.25

## Section 3: Maintenance

Valve parts are subject to normal wear and must be inspected and replaced as necessary. Inspection and maintenance frequency depends on the severity of service conditions. This section includes instructions for packing lubrication, packing maintenance and trim maintenance. All maintenance operations may be performed with the valve in the line.

**⚠ WARNING**

**Avoid personal injury or damage to property from sudden release of pressure or uncontrolled process fluid. Before starting disassembly:**

- **Do not remove the actuator from the valve while the valve is still pressurized.**
- **Always wear protective gloves, clothing and eyewear when performing any maintenance operations to avoid personal injury.**
- **Disconnect any operating lines providing air pressure, electric power or a control signal to the actuator. Be sure the actuator cannot suddenly open or close the valve.**
- **Use bypass valves or completely shut off the process to isolate the valve from process pressure. Relieve process pressure on both sides of the valve. Drain the process media from both sides of the valve.**
- **Vent the power actuator loading pressure and relieve any actuator spring precompression.**
- **Use lock-out procedures to be sure that the above measures stay in effect while you work on the equipment.**
- **The valve packing box may contain process fluids that are pressurized, even when the valve has been removed from the pipeline. Process fluids may spray out under pressure when removing the packing hardware or packing rings or when loosening the packing box pipe plug.**
- **Check with your process or safety engineer for any additional measures that must be taken to protect against process media.**

**NOTE**

The HP series valve uses spiral-wound gaskets which are crushed to provide their seal. A spiral-wound gasket should never be reused. Whenever a gasket seal is disturbed by removing or shifting gasketed parts, a new gasket must be installed upon reassembly. This is necessary to ensure a good gasket seal, since the used gasket will not seal properly.

**NOTICE**

**The spiral-wound gaskets are of special design. Failure to use Fisher replacement parts may result in valve damage.**

**Figure 2. Lubricator and Lubricator/Isolating Valve**

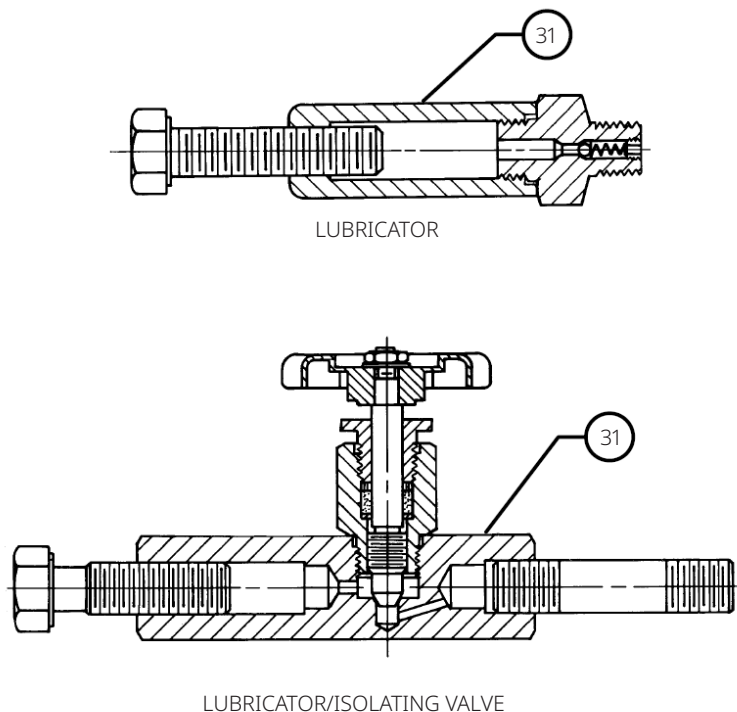

10A9421-A  
AJ5428-D  
A0832-2

**NOTE**

If the valve has ENVIRO-SEAL live-loaded packing installed (Figure 4), see the instruction manual entitled ENVIRO-SEAL Packing System for Sliding-Stem Valves (D101642X012) for packing instructions.

If the valve has HIGH-SEAL ULF live-loaded packing installed (Figure 4), see the instruction manual entitled HIGH-SEAL ULF Live-Loaded Packing System (D101453X012) for packing instructions.

### 3.1 Packing Lubrication

**NOTE**

Do not lubricate graphite packing. Graphite packing is self-lubricated. Additional lubrication may result in slip-stick movement of the valve.

**NOTE**

To avoid lubricants breaking down at elevated temperatures, do not lubricate packing used in processes with temperatures over 260 °C / 500 °F.

**⚠ WARNING**

**Do not lubricate parts when used in oxygen service, or where the lubrication is incompatible with the process media. Any use of lubricant can lead to the sudden explosion of media due to the oil/oxygen mixture, causing personal injury or property damage.**

If a lubricator or lubricator/isolating valve (Figure 2) is provided for PTFE/composition or other packings that require lubrication, it will be installed in place of the pipe plug (key 31, Figure 22, 23 or 24). Use a good quality silicon-base lubricant. Packing used in oxygen service or in processes with temperatures over 260 °C / 500 °F) should not be lubricated. To operate the lubricator, turn the cap screw clockwise to force the lubricant into the packing box. The lubricator/isolating valve operates the same way except the isolating valve must first be opened and then closed after lubrication is completed.

## 3.2 Packing Maintenance

If there is undesirable packing leakage in the spring-loaded PTFE V-ring packing shown in Figure 3, tighten the packing flange nuts (key 21, Figure 22, 23, 24, 26, 28, 30, 32, 34, 36 or 38) until the shoulder on the packing follower (key 28, Figure 22, 23, 24, 26, 28, 30, 32, 34, 36 or 38) contacts the bonnet (key 18, Figure 22, 23, 24, 26, 28, 30, 32, 34, 36 or 38). If leakage continues, replace the packing by following the numbered steps presented in the replacing packing procedure.

If there is undesirable packing leakage with other than spring-loaded PTFE V-ring packing, first try to limit the leakage and establish a stem seal by tightening the packing flange nuts (key 21, Figure 22, 23, 24, 26, 28, 30, 32, 34, 36 or 38) to at least the minimum recommended torque in Table 6. However, do not exceed the maximum recommended torque in Table 6 or excessive friction may result. If leakage continues, replace the packing by following the numbered steps presented in the Replacing Packing procedure.

If the packing is relatively new and tight on the valve plug stem, and if tightening the packing flange nuts does not stop the leakage, it is possible that the stem is worn or nicked so that a seal cannot be made. The surface finish of a new stem is critical for making a good packing seal. If the leakage comes from the outside diameter of the packing, it is possible that the leakage is caused by nicks or scratches around the packing box wall. While replacing the packing according to the Replacing Packing procedure, inspect the valve plug stem and packing box wall for nicks or scratches.

**Figure 3. Packing Arrangements**

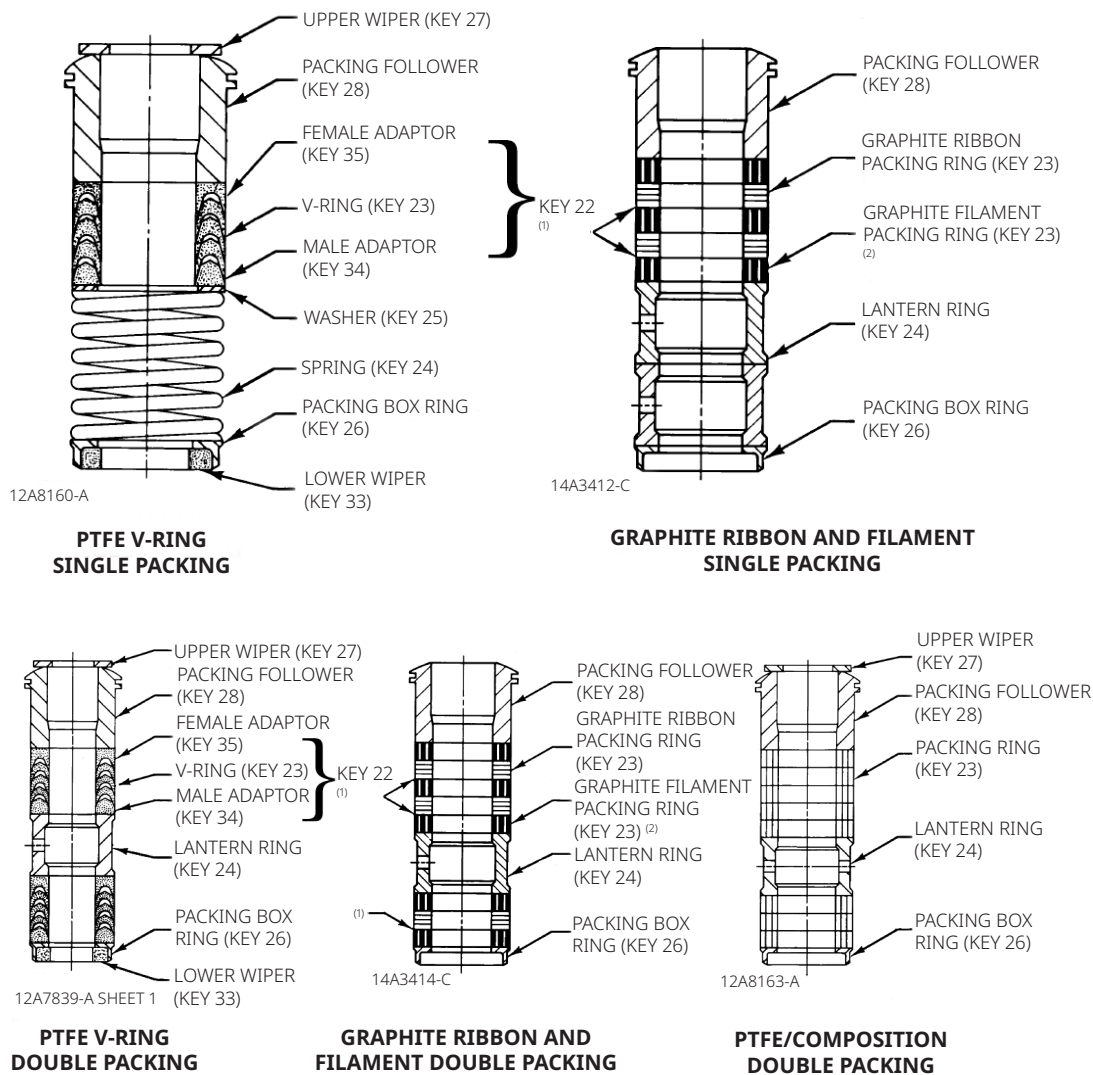

C0747-1

**NOTES:**

1. 0.102 mm / 0.004 IN. THICK SACRIFICIAL ZINC WASHERS. USE ONLY ONE BELOW EACH GRAPHITE RIBBON RING.
2. HAS THE APPEARANCE OF A WOVEN OR BRAIDED RING.

Figure 4. Live-Loaded Packing

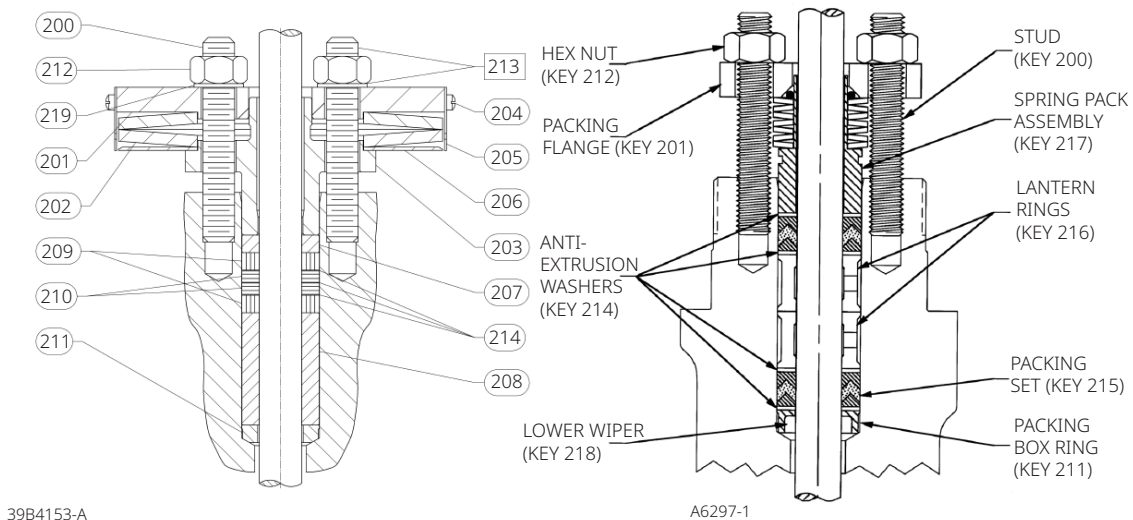

TYPICAL HIGH-SEAL GRAPHITE ULF PACKING SYSTEM

TYPICAL ENVIRO-SEAL PACKING SYSTEM WITH PTFE PACKING

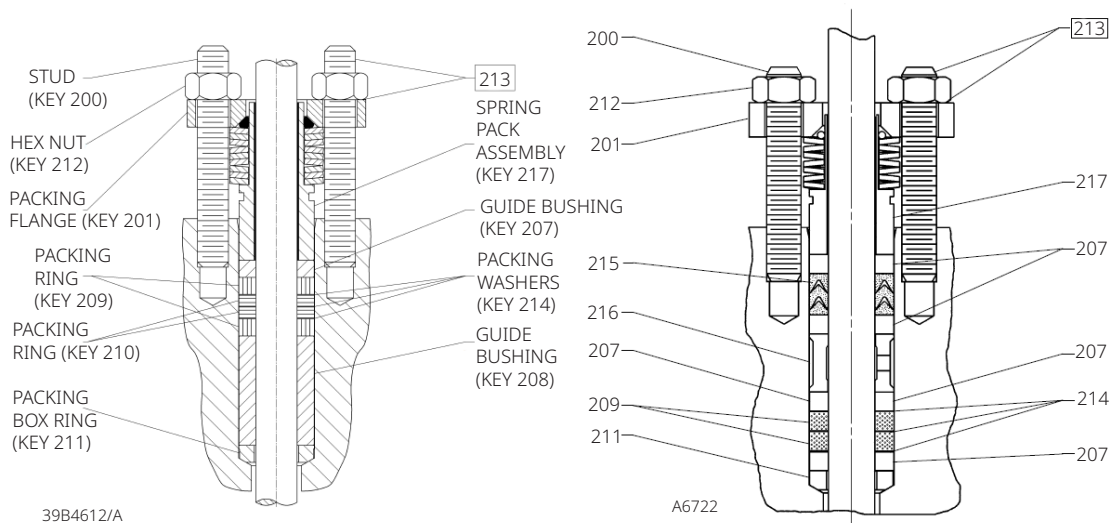

TYPICAL ENVIRO-SEAL PACKING SYSTEM WITH GRAPHITE ULF PACKING

TYPICAL ENVIRO-SEAL PACKING SYSTEM WITH DUPLEX PACKING

## Adding Packing Rings

Key numbers referred to in this procedure are shown in Figure 22, 23, 24, 26, 28, 30, 32, 34, 36 or 38 unless otherwise indicated. When using packing with a lantern ring (key 24), it may be possible to add packing rings above the lantern ring as a temporary measure without removing the actuator from the valve body.

1. Isolate the control valve from the line pressure, release pressure from both sides of the valve body and drain the process media from both sides of the valve. If using a power actuator, also shut-off all pressure lines to the power actuator, release all pressure from the actuator. Use lock-out procedures to be sure that the above measures stay in effect while you work on the equipment.
2. Remove the packing flange nuts (key 21) and lift the packing flange, upper wiper and packing follower (keys 19, 27 and 28) away from the valve body.
3. It may be possible to dig out the old packing rings on top of the lantern ring, but use care to avoid scratching the valve plug stem or packing box wall. Clean all metal parts to remove particles that would prevent the packing from sealing.
4. Remove the stem connector and slip the packing rings over the end of the valve plug stem.
5. Reassemble the packing follower, upper wiper, packing flange and packing flange nuts (keys 28, 27, 19 and 21).
6. Reconnect the body-actuator stem connection according to the appropriate actuator instruction manual.
7. Tighten the packing flange nuts only far enough to stop leakage under operating conditions. Check for leakage around the packing follower when the valve is being put into service. Retighten the packing flange nuts as required (see Table 6).

## Replacing Packing

### **WARNING**

**Refer to the WARNING at the beginning of the Maintenance section in this instruction manual.**

Key numbers referred to in this procedure are shown in Figure 22, 23, 24, 26, 28, 30, 32, 34, 36 or 38 unless otherwise indicated.

1. Isolate the control valve from the line pressure, release pressure from both sides of the valve body and drain the process media from both sides of the valve. If using a power actuator, also shut-off all pressure lines to the power actuator, release all pressure from the actuator. Use lock-out procedures to be sure that the above measures stay in effect while you work on the equipment.
2. Remove the cap screws in the stem connector, and separate the two halves of the stem connector. Then exhaust all actuator pressure, if any was applied, and disconnect the actuator supply and any leakoff piping.

3. Remove either the yoke locknut (key 32) or the hex nuts (key 30) and remove the actuator from the bonnet (key 18).
4. Loosen the packing flange nuts (key 21) so that the packing (keys 22, 23, 209 or 210, Figure 3) is not tight on the valve plug stem (key 6). Remove any travel indicator disk and stem locknuts from the valve plug stem threads.

## NOTICE

**When lifting the bonnet (key 18), be sure that the valve plug and stem assembly (keys 5 and 6) remains on the seat ring (key 4). This avoids damage to the seating surfaces as a result of the assembly dropping from the bonnet after being lifted part way out. The parts are also easier to handle separately.**

**Use care to avoid damaging gasket sealing surfaces.**

**The HPD and HPAD piston rings (key 8) are brittle and in two pieces. Avoid damaging the piston rings by dropping or rough handling.**

## WARNING

**To avoid personal injury or property damage caused by uncontrolled movement of the bonnet, loosen the bonnet by following the instructions in the next step. Do not remove a stuck bonnet by pulling on it with equipment that can stretch or store energy in any other manner. The sudden release of stored energy can cause uncontrolled movement of the bonnet. If the cage sticks to the bonnet, proceed carefully with bonnet removal and support the cage so that it will not fall unexpectedly from the bonnet.**

## NOTE

The following step also provides additional assurance that the valve body fluid pressure has been relieved.

5. Hex nuts (key 14) attach the bonnet to the valve body. Loosen these nuts or cap screws approximately 3 mm / 1/8 in. Then loosen the body-to-bonnet gasketed joint by either rocking the bonnet or prying between the bonnet and valve body. Work the prying tool around the bonnet until the bonnet loosens. If no fluid leaks from the joint, proceed to the next step.
6. Unscrew the hex nuts (key 14) and carefully lift the bonnet off the valve stem. If the valve plug and stem assembly starts to lift with the bonnet, use a brass or lead hammer on the end of the stem and tap it back down. Set the bonnet on a cardboard or wooden surface to prevent damage to the bonnet gasket surface.
7. Remove the valve plug (key 5), bonnet gasket (key 11), cage (key 2), seat ring (key 4) and the seat ring gasket (key 12).

**NOTE**

Inspect the seat ring, cage, bonnet and body gasket surfaces. These surfaces must be in good condition, with all foreign material removed. Small burrs less than approximately 0.076 mm / 0.003 in. in height (the thickness of a human hair) can be ignored. Scratches or burrs that run across the serrations are not permitted under any conditions, since they will prevent the gaskets from sealing properly.

8. Clean all gasket surfaces with a good wire brush. Clean in the same direction as the surface serrations, not across them.
9. Cover the opening in the valve body to protect the gasket surface and to prevent foreign material from getting into the valve body cavity.
10. Remove the packing flange nuts (key 21), packing flange (key 19), upper wiper (key 27) and packing follower (key 28). Carefully push out all the remaining packing parts from the valve side of the bonnet using a rounded rod or other tool that will not scratch the packing box wall. For extension bonnets, also remove the baffle (key 36 ) and retaining ring (key 37).
11. Clean the packing box and the following metal packing parts: packing follower, packing box ring (key 26), spring or lantern ring (key 24) and, for single arrangements of PTFE V-ring packing only, special washer (key 25).
12. Inspect the valve stem threads for any sharp edges that might cut the packing. A whetstone or emery cloth may be used to smooth the threads, if necessary.
13. Remove the protective covering from the valve body cavity, and install the seat ring, cage and cage retainer (as provided) using a new seat ring gasket (key 12) and bonnet gasket (key 11). Install the plug, then slide the bonnet over the stem and onto the studs (key 13). For a valve body with extension bonnet, also install the baffle and retaining rings (keys 36 and 37).

**NOTE**

The prelubricated hex nuts (key 14) referred to in step 14 can be identified by a black film coating on the nut threads. The proper bolting procedures in step 14 include—but are not limited to—ensuring that the bonnet stud threads are clean and that the hex nuts are evenly tightened to the specified torque values.

**Table 9. Valve Stem Connection Torque and Drill Size for Pin Hole**

HP	HPA	VALVE STEM DIAMETER		DESIGN	VALVE STEM CONNECTION TORQUE <sup>(2)</sup> (MINIMUM-MAXIMUM)		DRILL SIZE FOR PIN
		mm	in.		N•m	Lbf•ft	in.
1	1	12.7	1/2	HPS, HPAS	81 to 115	60 to 85	1/8
		19.1	3/4	HPS, HPAS	237 to 339	175 to 250	3/16
2	2, 3	12.7	1/2	HPD, HPAD, HPS, HPAS <sup>(1)</sup> , HPT, HPAT	81 to 115	60 to 85	1/8
		19.1	3/4	HPS, HPAS <sup>(1)</sup>	237 to 339	175 to 250	3/16
				HPD, HPAD, HPT, HPAT	237 to 339	175 to 250	1/8
25.4	1	HPS, HPAS <sup>(1)</sup>	420 to 481	310 to 355	1/4		

- continued -

**Table 9. Valve Stem Connection Torque and Drill Size for Pin Hole (continued)**

HP	HPA	VALVE STEM DIAMETER		DESIGN	VALVE STEM CONNECTION TORQUE <sup>(2)</sup> (MINIMUM-MAXIMUM)		DRILL SIZE FOR PIN
		mm	in.		N•m	Lbf•ft	in.
VALVE SIZE, NPS							
3	4	12.7	1/2	HPD, HPS, HPT, HPAD, HPAT	81 to 115	60 to 85	1/8
		19.1	3/4	HPD, HPS, HPT, HPAD, HPAT	237 to 339	175 to 250	3/16
		25.4	1	HPD, HPS, HPT, HPAD, HPAT	420 to 481	310 to 355	1/4
4	6	19.1	3/4	HPD, HPT, HPAD, HPAT	237 to 339	175 to 250	3/16
		25.4	1	HPD, HPT, HPAD, HPAT	420 to 481	310 to 355	1/4
6	8	19.1	3/4	HPD, HPT, HPAD, HPAT	237 to 339	175 to 250	3/16
		25.4	1	HPD, HPT, HPAD, HPAT	420 to 481	310 to 355	1/4
		31.8	1-1/4	HPD, HPT, HPAD, HPAT	827 to 908	610 to 670	1/4
8	N/A	25.4	1	HPD, HPT	420 to 481	310 to 355	1/4
		31.8	1-1/4	HPD, HPT	827 to 908	610 to 670	1/4
		50.8	2	HPD, HPT	3515 to 3885	2600 to 2880	3/8
10	12	25.4	1	HPD, HPT, HPAD, HPAT	420 to 481	310 to 355	1/4
		31.8	1-1/4	HPD, HPT, HPAD, HPAT	827 to 908	610 to 670	1/4
		50.8	2	HPD, HPT, HPAD, HPAT	3515 to 3885	2600 to 2880	3/8
12	N/A	25.4	1	HPD, HPT	420 to 481	310 to 355	1/4
		31.8	1-1/4	HPD, HPT	827 to 908	610 to 670	1/4
		50.8	2	HPD, HPT	3515 to 3885	2600 to 2880	3/8
14	N/A	31.8	1-1/4	HPD, HPT	827 to 908	610 to 670	1/4
		50.8	2	HPD, HPT	3515 to 3885	2600 to 2880	3/8
16	N/A	31.8	1-1/4	HPD, HPT	827 to 908	610 to 670	1/4
		50.8	2	HPD, HPT	3515 to 3885	2600 to 2880	3/8
18	N/A	31.8	1-1/4	HPD, HPT	827 to 908	610 to 670	1/4
		50.8	2	HPD, HPT	3515 to 3885	2600 to 2880	3/8
20	N/A	31.8	1-1/4	HPD, HPT	827 to 908	610 to 670	1/4
		50.8	2	HPD, HPT	3515 to 3885	2600 to 2880	3/8
24	N/A	31.8	1-1/4	HPD, HPT	827 to 908	610 to 670	1/4
		50.8	2	HPD, HPT	3515 to 3885	2600 to 2880	3/8

1. HPAS available in NPS2 only.  
 2. Lubricate with anti-seize lubricant.

**NOTICE**

**Failure to comply with good bonnet-to-body bolting practices and the torque values shown in Table 7 may result in damage to the valve. Cheater bars or slug wrenches should not be used for this procedure.**

**Hot torquing is not recommended.**

**NOTE**

Stud(s) and nut(s) should be installed such that the manufacturer's trademark and material grade marking is visible, allowing easy comparison to the materials selected and documented in the Emerson/Fisher serial card provided with this product.

**⚠ WARNING**

**Personal injury or damage to equipment could occur if improper stud and nut materials or parts are used. Do not operate or assemble this product with stud(s) and nut(s) that are not approved by Emerson/Fisher engineering and/or listed on the serial card provided with this product. Use of unapproved materials and parts could lead to stresses exceeding the design or code limits intended for this particular service. Install studs with the material grade and manufacturer's identification mark visible. Contact your Emerson sales office immediately if a discrepancy between actual parts and approved parts is suspected.**

14. Lubricate the stud threads, the faces of the hex nuts (key 14) and washer face with anti-seize lubricant (not necessary if new factory prelubricated hex nuts are used). Replace the hex nuts and tighten them finger-tight. Stroke the valve several times to center the trim. Torque the nuts in a crisscross pattern to no more than 1/4 of the nominal torque value specified in Table 7.

When all nuts are tightened to that torque value, increase the torque by 1/4 of the specified nominal torque and repeat the crisscross pattern. Repeat this procedure until all nuts are tightened to the specified nominal value. Apply the final torque value again and, if any nut still turns, tighten every nut again.

**NOTE**

When installing packing rings, prevent entrapping air between the rings. Add the rings one at a time without forcing them below the chamfer of the packing box entrance chamber. As each successive ring is added, the stack should not be pushed down more than the thickness of the added ring (Figure 5).

15. Install new packing and the metal packing box parts according to the appropriate arrangement in Figure 3. If desired, packing parts may be pre-lubricated with a silicon base grease for easier installation. Slip a smooth-edged pipe over the valve stem, and gently tamp each soft packing part into the packing box, being sure that air is not trapped between adjacent soft parts.
16. Slide the packing follower, wiper and packing flange into position. Lubricate the packing flange studs (key 20) and the faces of the packing flange nuts (key 21). Replace the packing flange nuts.

For the spring-loaded PTFE V-ring packing shown in Figure 3, tighten the packing flange nuts until the shoulder on the packing follower (key 28) contacts the bonnet.

**Figure 5. Installing Graphite Ribbon/Filament Packing Rings One at a Time**

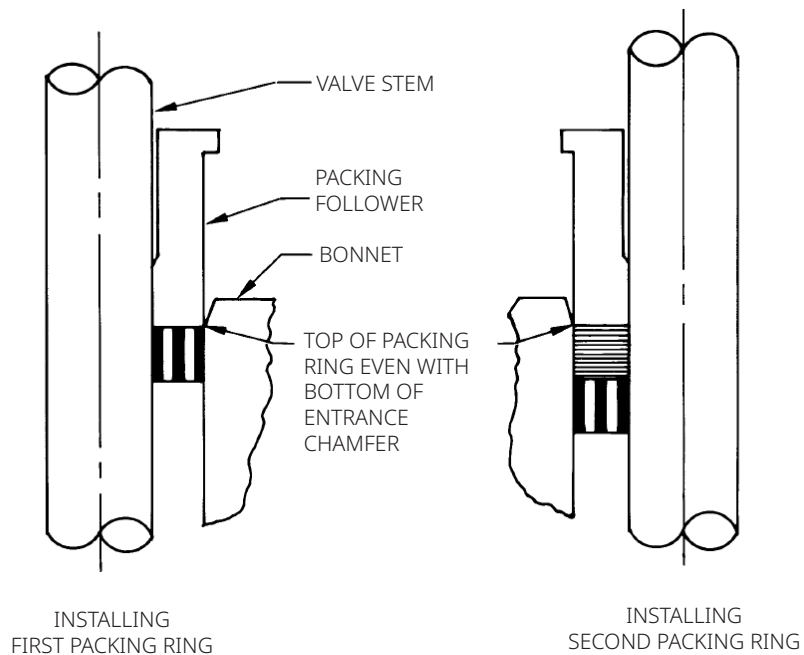

A2207-2

For graphite packing, tighten the packing flange nuts to the maximum recommended torque shown in Table 6. Then, loosen the packing flange nuts and retighten them to the recommended minimum torque shown in Table 6.

For other packing types, tighten the packing flange nuts alternately in small equal increments until one of the nuts reaches the minimum recommended torque shown in Table 6. Then, tighten the remaining flange nuts until the packing flange is level and at a 90-degree angle to the valve stem.

For ENVIRO-SEAL or HIGH-SEAL live-loaded packing, refer to the note at the beginning of the Maintenance section.

17. Mount the actuator on the valve body assembly, and reconnect the actuator and valve plug stems according to the procedures in the appropriate actuator instruction manual.

### 3.3 Trim Removal

For C-seal construction, see the appropriate C-seal sections in this manual.

For bore seal construction, see the appropriate bore seal sections in this manual.

Key numbers referenced in this procedure are shown in Figure 22, 23, 24, 26, 28, 30, 32, 34, 36 or 38 except where indicated.

1. Remove the actuator and bonnet by following steps 1 through 6 of the replacing packing procedure. Observe all warnings and cautions.
2. Lift the valve stem and attached valve plug out of the valve body. If the valve plug is to be reused, tape or otherwise protect the valve plug stem and the valve plug seating surface to prevent scratches.
3. Lift out the cage retainer (key 45) (as required), cage (key 2) and the bonnet gasket (key 11). For an NPS 2 valve body with a Cavtrol III two stage cage, also remove the bonnet spacer and two gaskets. For NPS 8 to 24 HPD and HPT, follow step 4 to lift the cage.
4. Remove the seal rings (key 42), as required, and retainer ring (key 37) and set aside.
5. Install threaded rods (about 6-in. long) in to the holes on the top of the cage vertically, as required. Install hoist rings, nuts or eye bolt on to the threaded rods. Lift the cage with the hoist nut from the valve body.

#### **⚠ WARNING**

**Lifting of the cage must be done with a vertical, or straight, lift using the equipment shown in Figure 6. Lifting at an angle may damage the lifting equipment and cause property damage or personal injury.**

6. Remove and discard all spiral wound gaskets (keys 43 and 11).

**Figure 6. Removal of Cage with Hoist Rod and Nut**

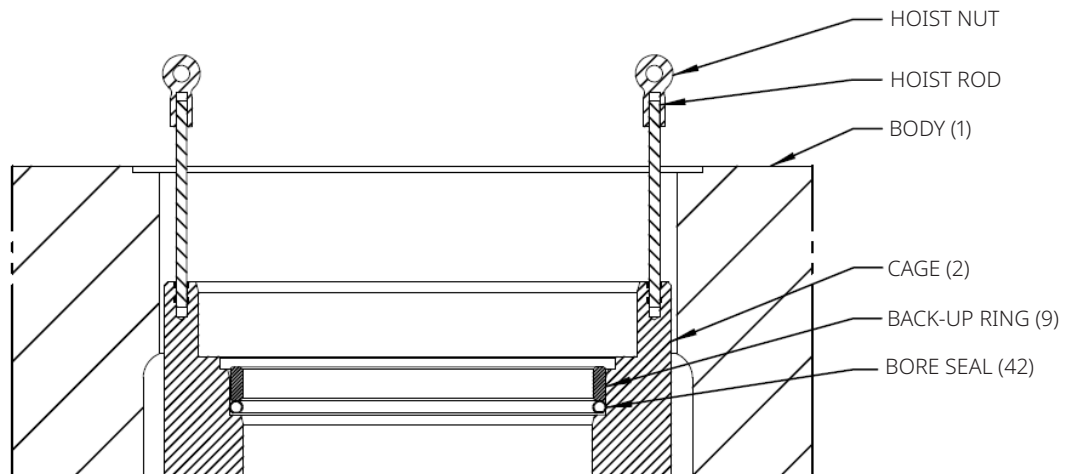

---

**NOTE**

The cage and cage retainer lifting holes are provided for ease of disassembly. To prevent damage to the cage lifting hole, fully engage the threaded rod into the cage hole, but do not overtighten the hoist rod. It only needs to be hand tight.

If it is hard to lift the cage, a piece of wood and a hammer can be used to strike on the top chamfer of the cage to loosen it from the body or seat ring gasket.

ASTM A193 B7 or comparable threaded rods are required for cage removal.

Contact your [Emerson sales office](#) for more information.

---

## Constructions other than TSO Trim

1. Remove the seat ring (key 4) and the seat ring gasket (key 12).
2. Refer to the Valve Plug Maintenance procedure or to the Lapping Seats procedure.

## TSO Trim

### TSO Trim: 0.8125 In. Port Diameter (Figure 8)

1. Remove the pin that locks the inner plug to the stem.
2. Using a strap wrench or similar tool, unscrew the outer plug from the inner plug. Do not damage the outer plug guide surfaces.
3. Remove the protected soft seat seal.
4. Inspect the parts for damage and replace, if needed.
5. Refer to the Valve Plug Maintenance procedure or to the Lapping Seats procedure.

### TSO Trim: 1.6875 In. Port Diameter (Figure 9)

1. Remove the retainer, backup ring, anti-extrusion rings and piston ring.
2. Remove the set screws that lock the outer plug to the stem.
3. Using a strap wrench or similar tool, unscrew the outer plug from the inner plug. Do not damage the outer plug guide surfaces.
4. Remove the protected soft seat seal.
5. Inspect the parts for damage and replace if needed.
6. Refer to the Valve Plug Maintenance procedure or to the Lapping Seats procedure.

### TSO Trim: 2.6875 In. and Larger Port Diameters (Figure 10)

1. Remove the retainer, backup ring, anti-extrusion rings and piston ring.
2. Remove the set screws that lock the outer plug to the inner plug.
3. Using a strap wrench or similar tool, unscrew the outer plug from the inner plug. Do not damage the outer plug guide surfaces.
4. Remove the protected soft seat seal.
5. Inspect the parts for damage and replace, if needed.
6. Refer to the Valve Plug Maintenance procedure or to the Lapping Seats procedure.

## 3.4 Valve Plug Maintenance

Key numbers used in this procedure are shown in Figure 22, 23, 24, 26, 28, 30, 32, 34, 36 or 38 except where indicated.

1. With the valve plug (key 5) removed according to the trim removal procedure, proceed as appropriate:

For HPD and HPAD valves, the piston rings (key 8) are each in at least two sections; remove the sections from the grooves in the valve plug.

For HPS and HPAS valves, proceed to step 2.

For HPT and HPAT valves, work the retaining ring (key 10) off the valve plug with a screwdriver. Carefully slide the backup ring and seal ring (keys 9 and 8) off the valve plug.

2. To replace the valve plug stem (key 6), drive out the pin (key 7) and unscrew the stem from the valve plug.

### NOTICE

**Never reuse an old stem with a new valve plug. Using an old stem with a new plug requires drilling a new pin hole in the stem. This weakens the stem and may cause the stem to fail in service. If a new valve plug is required, always order a valve plug, stem and pin as an assembly. Specify the correct part number of each of the three parts, but state that the parts are being ordered as an assembly.**

**A used valve plug may be reused with a new stem.**

**Figure 7. Detail of Protected Soft Seat**

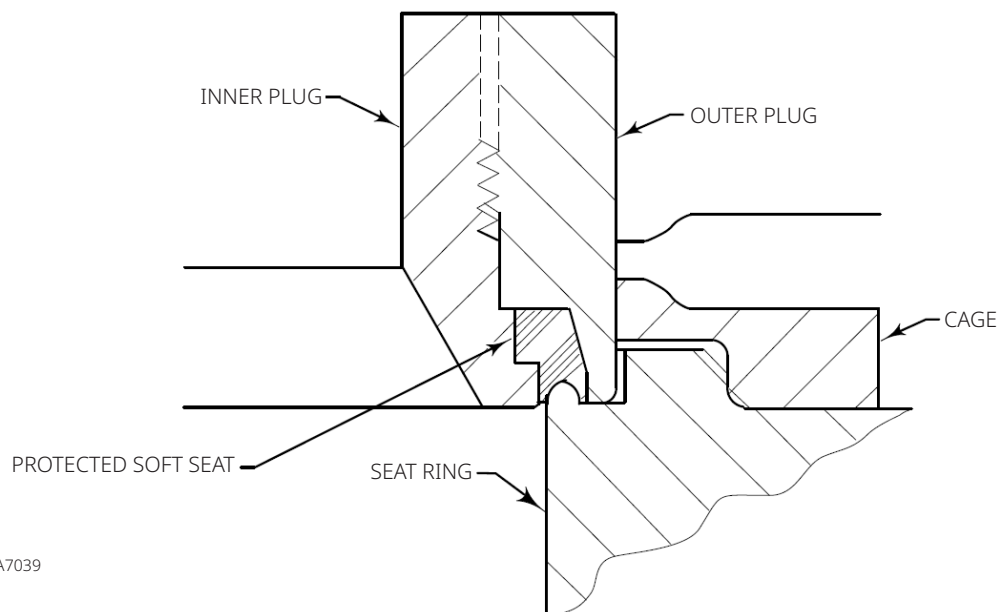

A7039

3. Thread the new stem into the valve plug and tighten it to the appropriate torque value given in Table 9. Using the valve plug pin hole as a guide, drill the pin hole through the stem. Refer to Table 9 for drill sizes.
4. Drive in the pin to lock the assembly.
5. If it is necessary to lap the seating surfaces, complete the lapping seats procedure before installing the HPD/HPAD piston rings or the HPT/HPAT seal ring. The Trim Replacement procedure provides piston ring and seal ring installation instructions and valve reassembly instructions.

## 3.5 Lapping Seats

Key numbers referenced in this procedure are shown in Figure 22, 23, 24, 26, 28, 30, 32, 34, 36 or 38 except where indicated.

A certain amount of leakage should be expected with metal-to-metal seating in any valve body. If the leakage becomes excessive, however, the condition of the seating surfaces of the valve plug and seat ring can be improved by lapping. (Deep nicks should be machined out rather than ground out.) Use a good quality lapping compound of a mixture of 280 to 600-grit. Apply the compound to the bottom of the valve plug.

**Figure 8. Typical Unbalanced TSO Trim Assembly, Small Port Designs (0.8125 In. Port Diameter)**

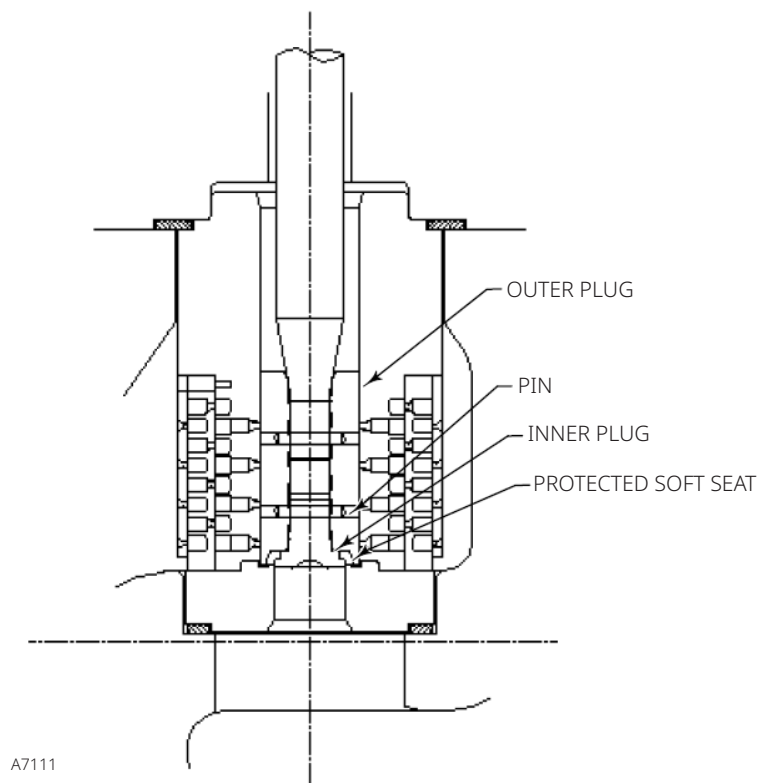

**NOTE**

HP Series valves use spiral-wound gaskets. These gaskets provide their seal by being crushed and therefore should never be reused. This includes reusing a gasket after the lapping procedure has been performed.

An “old” gasket can be used to lap the seat, however the gasket must be replaced with a new gasket.

To preserve the effects of lapping, do not change either the position of the seat ring in the valve body cavity or the position of the cage on the seat ring after lapping the seating surfaces. When the parts are removed for cleaning and replacement of the “old” gaskets, return them to the original positions.

**Figure 9. Typical Balanced TSO Trim (1.6875 In. Port Diameter)**

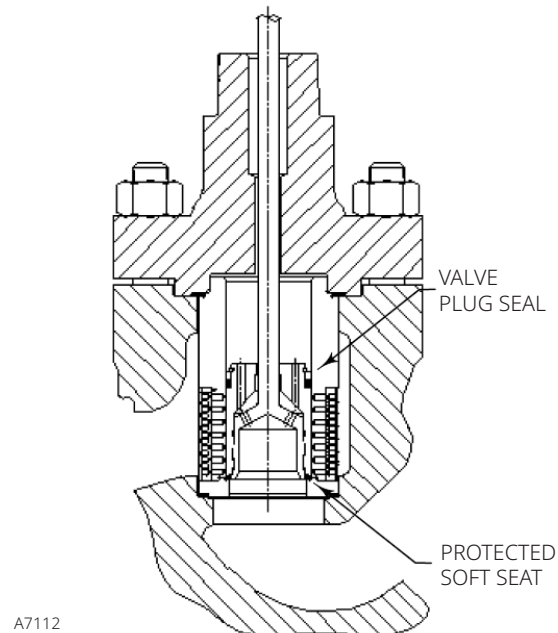

A7112

Use the following procedure to lap the seating surfaces.

1. Install the following parts according to the instructions presented in the trim replacement procedure: “old” seat ring gasket (key 12), seat ring (key 4), cage (key 2) and “old” bonnet gasket (key 11).
2. Proceed as appropriate:  
 For an HPD, HPAD, HPT or HPAT valve, install the valve plug and stem assembly (keys 5 and 6)–without piston rings or seal ring (key 8) –into the cage.  
 For an HPS or HPAS valve, install the valve plug and stem assembly (keys 5 and 6) into the cage.
3. Install the bonnet (key 18) over the valve stem, and secure the bonnet with four of the hex nuts (key 14).
4. Attach a handle, such as a piece of strap iron secured by stem locknuts, to the valve stem. Rotate the handle alternately in each direction to lap the seats.
5. After lapping, disassemble as necessary (you may mark the position of the seat ring and cage with a soft tip marker). Clean the seating surfaces, replace the gaskets, reassemble (taking care to return the seat ring and cage to their original positions) and test for shutoff. Repeat the lapping procedure if necessary.

**Figure 10. Typical Balanced TSO Trim, Large Port Designs (2.6875 In. and Larger Port Diameters)**

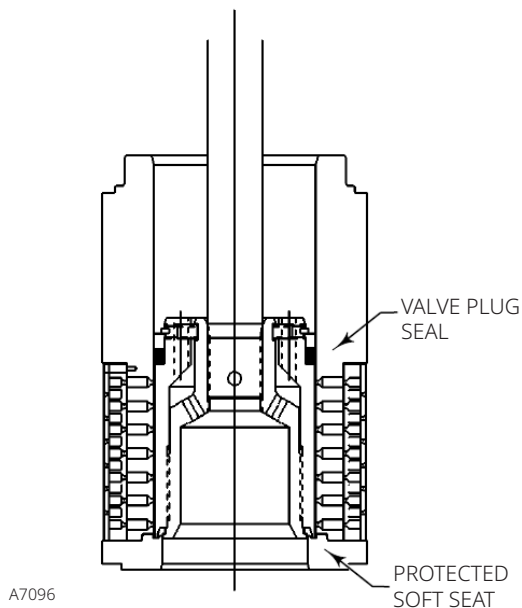

**Table 10. Actuator Groups by Type Number**

<b>Group 1</b> 71 and 90 mm / 2-13/16 and 3-9/16 in. Yoke Boss	<b>Group 100</b> 127 mm / 5-in. Yoke Boss
472 and 473 585C 1B 644 and 645 655 657 and 667 685SE and 685SR 1008	472 473 474 476 585C 657 685 785C
	<b>Group 101</b> 127 mm / 5-in. Yoke Boss
	667
<b>Group 407</b> 127 mm / 5-in. Yoke Boss	<b>Group 802</b> 127 mm / 5-in. Yoke Boss
585C 657 685 785C	585C 685 785C
<b>Group 803</b> 127 mm / 5-in. Yoke Boss 178 mm / 7-in. Yoke Boss	<b>Group 805</b> 178 mm / 7-in. Yoke Boss
685 785C	685 785C

## 3.6 Trim Replacement

### **WARNING**

**Observe the warning at the start of the Maintenance section.**

After all trim maintenance has been completed, reassemble the valve body by following the numbered steps below. Be certain that all gasketed surfaces have been well cleaned. Key numbers referenced in this procedure are shown in Figure 22, 23, 24, 26, 28, 30, 32, 34, 36 or 38 except where indicated.

#### **NOTE**

Inspect the seat ring, cage, cage retainer (as provided), bonnet and body gasket surfaces. These surfaces must be in good condition, with all foreign material removed. Small burrs less than approximately 0.076 mm / 0.003 in. in height (the thickness of a human hair) can be ignored. Scratches or burrs that run across the serrations are not permitted under any conditions, since they will prevent the gaskets from sealing properly.

#### **NOTE**

The pressure balancing holes in the valve plug are necessary for the proper and safe operation of the valve. Inspect the balancing holes every time the valve is disassembled for service. Any build-up, blockage or clogging of the balance holes should be removed.

## NPS 2 to 6 HPD (Long), HPT (Long) and NPS 2 to 8 CL1500 HPAD and HPAT

### Constructions other than TSO Trim

#### **NOTE**

When installing the standard cage, align two of the holes in the cage with the centerline of the valve body. Refer to Figure 23.

1. Install the seat ring gasket (key 12) into the valve body. Install the seat ring (key 4).
2. Install the cage.
3. To install the piston rings and seal rings (key 8), proceed as appropriate:

For an HPD or HPAD valve, if it is necessary to install new piston rings, the replacement piston rings will arrive in one piece. Use a vise with smooth or taped jaws to break a replacement piston ring into halves. Place the new ring in the vise so that the jaws compress the ring into an oval. Compress the ring slowly until the ring snaps on both sides. If one side snaps first, do not try to tear or cut the other side. Instead, keep compressing until the other side snaps. The piston ring can also be fractured by scoring and snapping over a hard surface such as a table edge. Sawing or cutting is not recommended.

Remove any protective tape or covering from the valve plug and stem assembly, and set it on a protective surface. Then, place the piston rings in the piston ring grooves with the fractured ends matched.

For an HPT or HPAT valve, install the seal ring (key 8) onto the valve plug (key 5). Install the ring with the open side facing the seat ring end of the valve plug for flow-down applications (view A of Figure 25) or with the open side facing the valve plug stem end of the valve plug for flow-up applications (view B of Figure 25). Slide the backup ring (key 9) onto the valve plug. Secure with the retaining ring (key 10).

For an HPAS Micro-Flat valve, ensure the Micro-Flat valve plug and stem assembly is oriented as shown in Figure 11 when replacing the bonnet on the valve body. Then slide the bonnet over the stem and onto the stud bolts.

#### NOTE

Micro-flat plugs must be installed as shown in Figures 11 and 23. This proper plug orientation increases the guide support area for the plug and stem.

**Figure 11. Micro-Flat Valve Plug Orientation**

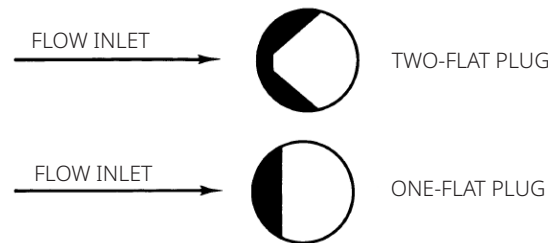

A5602

4. Install the valve plug into the cage.
5. Install the bonnet gasket (key 11) on the cage.
6. Install the bonnet over the valve stem and onto the valve body.

## TSO Trim

### TSO Trim: 0.8125 In. Port Diameter (Figure 8)

1. Thread the outer plug onto the inner plug until the parts seat metal to metal, using a strap wrench or similar tool that will not damage the outer plug guide surfaces.
2. Mark the inner plug and outer plug with alignment marks in the assembled position.
3. Disassemble the outer plug from the inner plug and install the seal over the inner plug, so that the seal rests below the threaded area.
4. Thread the outer plug onto the inner plug and tighten with a strap wrench or similar tool until the alignment marks line up. This will ensure that the plug parts are metal to metal and the seal is compressed properly. Do not damage the outer plug guide surfaces.
5. Drill through the inner plug with the proper size drill bit (same size as stem pinning) and install the pin.
6. Install the bonnet gasket (key 11) on the cage.
7. Install the bonnet over the valve stem and onto the valve body.

### TSO Trim: 1.6875 In. Port Diameter (Figure 9)

1. Thread the outer plug onto the inner plug until the parts seat metal to metal, using a strap wrench or similar tool that will not damage the outer plug guide surfaces.
2. Mark the top of the outer plug and stem with alignment marks in the assembled position.
3. Disassemble the outer plug from the inner plug and install the seal over the inner plug, so that the seal rests below the threaded area.
4. Thread the outer plug onto the inner plug and tighten with a strap wrench or similar tool until the alignment marks line up. This will ensure that the plug parts are metal to metal and the seal is compressed properly. Do not damage the outer plug guide surfaces.
5. Install set screws centering the stem in the outer plug and torque to 11 N•m / 8 lbf•ft.
6. Assemble the piston ring, anti-extrusion rings, backup ring and retainer.
7. Install the bonnet gasket (key 11) on the cage.
8. Install the bonnet over the valve stem and onto the valve body.

### TSO Trim: 2.6875 In. and Larger Port Diameters (Figure 10)

1. Thread the outer plug onto the inner plug until the parts seat metal to metal, using a strap wrench or similar tool that will not damage the outer plug guide surfaces.
2. Mark the top of the inner plug and outer plug with alignment marks in the assembled position.
3. Disassemble the outer plug from the inner plug and install the seal over the inner plug, so that the seal rests below the threaded area.
4. Thread the outer plug onto the inner plug and tighten with a strap wrench or similar tool until the alignment marks line up. This will ensure that the plug parts are metal to metal and the seal is compressed properly. Do not damage the outer plug guide surfaces.
5. Install set screws centering the inner plug in the outer plug and torque to 11 N•m / 8 lbf•ft.
6. Assemble the piston ring, anti-extrusion rings, backup ring and retainer.
7. Install the bonnet gasket (key 11) on the cage.
8. Install the bonnet over the valve stem and onto the valve body.

### NPS 8 to 24 HPD and HPT and NPS 12 HPAD/HPAT Constructions (Figures 26, 27, 28, 29, 30, 31, 32, 33, 38, 39 and 40)

1. Install the seat ring flat sheet gasket (key 12) in the lower gasket groove in the valve body (key 1), making sure the gasket is centered in the groove and the bottom of the gasket is flush with the mating surface in the body.
2. If applicable, install the seat ring (key 4) into the valve body. Lift using hoist rings on threaded rods threaded into the lift holes provided. Take care to lower the seat ring evenly and ensure the seat ring will not damage the flat sheet gasket (key 12).
3. If required, slip quantity-1 seal ring (key 42) onto the lowest groove of cage with the open side of the seal ring facing the top or bottom of the seat ring, depending on flow direction. Make sure the anti-extrusion ring is on the closed side of the seal ring and the tapered face of anti-extrusion ring and the seal ring match correctly, see Figure 12.

**Figure 12. Soft Seal Detail and Installed Orientation**

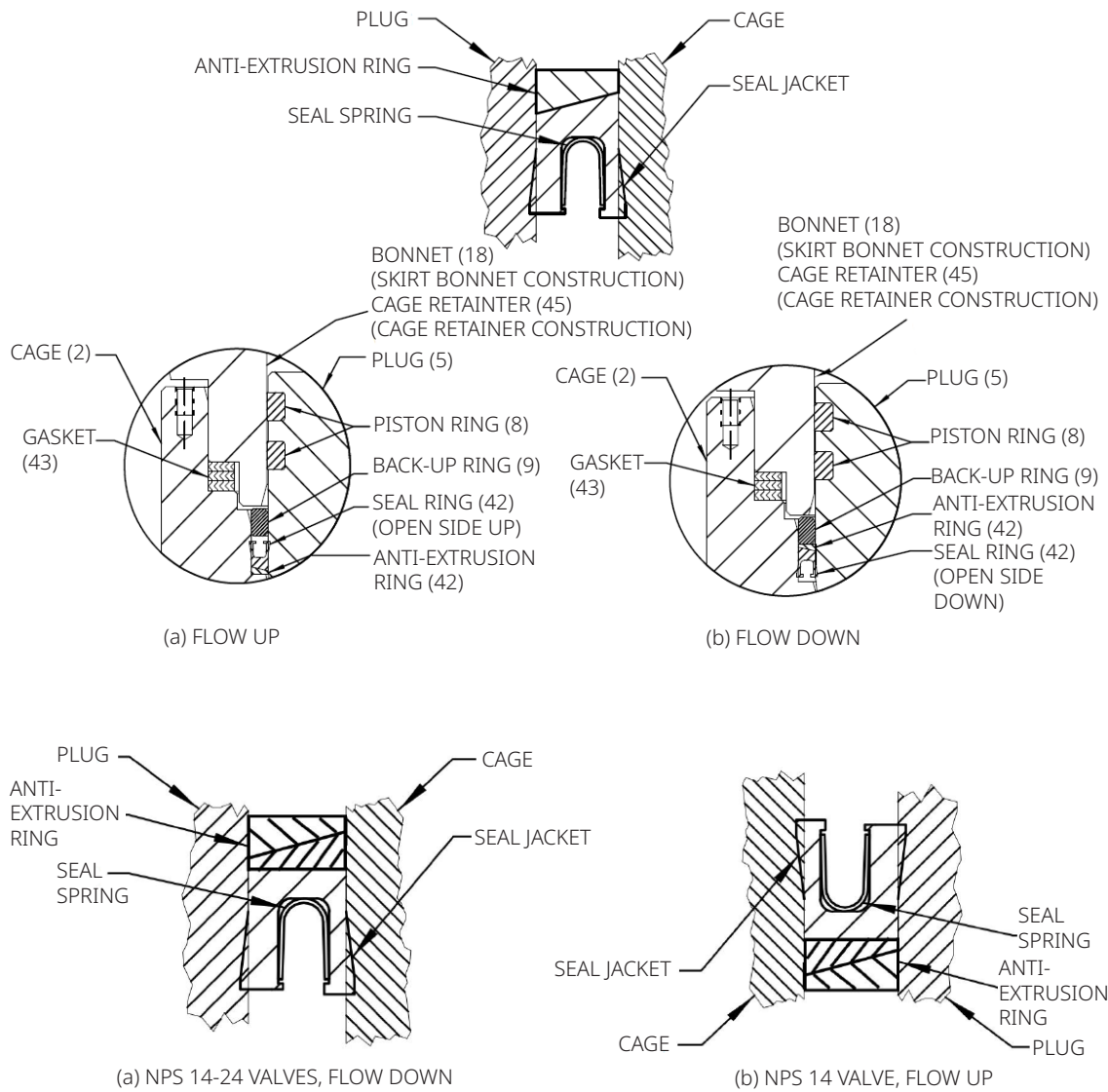

**NOTE**

The anti-extrusion ring is NOT reversible. There is a flat face side and a tapered face side. The tapered face side of the anti-extrusion ring matches a tapered face on the seal ring. The seal will not function properly if it is not assembled correctly. The seal installation should be done prior to cage installed into the valve. When install a bore seal ring, refer to the bore seal Trim section.

4. Place the backup ring (key 9) into the seal groove until it touches the seal ring (key 42).
5. Install threaded rods (about 6 in. long) in to the holes on the top of the cage. Install hoist rings, nuts or eye bolt on to the threaded rod.

---

**NOTE**

To prevent damage to the cage/seal ring lifting holes, fully engage the threaded rod into the cage/seal ring hole, but do not overtighten the hoist rod. It only needs to be hand tight. ASTM A193 B7 or comparable threaded rods are required for cage/seal ring installation.

---

6. Install the cage (key 2) into the valve body, lift the cage using the hoist rings on the threaded rods. When installing the cage (key 2), take care to lower the cage evenly and ensure that cage (key 2) will not damage the flat sheet gasket (key 12) or the seat ring (key 4).

---

**NOTE**

If a drilled hole cage is used, blow out the cage and drilled holes before installing into the body to make sure the burrs and debris will not be trapped between cage and plug and cause damage.

---

7. For NPS 8 through 12 valves with skirted bonnet install quantity-3 cage spiral wound gaskets (key 43) for NPS 8 through 14 valves with cage retainer (key 45) install quantity-2, for NPS 16 through 24 valves with cage retainer (key 45) install quantity 3, making sure the gaskets sits flush on the surface of the groove.
8. If applicable, install the cage retainer (key 45) on top of the cage. For NPS 8 through 12 valves install a single spiral wound gasket (key 43) in the gasket groove on top of the cage retainer. For the NPS 14 valve install quantity-2 gaskets in the gasket groove on top of the cage retainer. For NPS 8 through 12 valves install a single spiral wound gasket (key 43) in the gasket groove on top of the cage retainer.
9. Install the bonnet gasket (key 11) in to the groove around the valve body trim opening.
10. Install quantity-2 piston rings (key 8) into the grooves on the plug (key 5).

---

**NOTE**

If it is necessary to install new piston rings, the replacement piston rings will arrive in one piece. Use a vise with smooth or taped jaws to break a replacement piston ring into halves. Place the new ring in the vise so that the jaws compress the ring into an oval. Compress the ring slowly until the ring snaps on both sides. If one side snaps first, do not try to tear or cut the other side. Instead, keep compressing until the other side snaps. The piston ring can also be fractured by scoring and snapping over a hard surface such as a table edge. Sawing or cutting is not recommended.

---

11. Place the plug/stem assembly into the bore of the cage (key 2) and gently rest the plug seating surface against the seating surface in the cage and make sure piston rings do not come out.
12. Lower the bonnet (key 18) over the valve plug stem, ensuring the valve stem is centered with the bonnet. This is important so that the top of the stem will engage the packing bore hole in the bonnet. Continue to lower the bonnet over the cage retainer.

**NOTE**

Be careful to prevent the bonnet from crushing the spiral wound gaskets as the bonnet is lowered on to the valve.

Damaging the gaskets will require that they are replaced.

The prelubricated hex nuts (key 14) referred to in step 13 can be identified by a black film coating on the nut threads.

The proper bolting procedures in step 13 include--but are not limited to--ensuring the bonnet stud threads are clean, and the hex nuts are evenly tightened to the specified torque values.

**NOTICE**

**Failure to comply with good bonnet-to-body bolting practices and the torque values shown in Table 7 may result in damage to the valve. Cheater bars or slug wrenches should not be used for this procedure. Hot torquing is not recommended.**

**NOTE**

Stud(s) and nut(s) should be installed such that the manufacturer's trademark and material grade marking is visible, allowing easy comparison to the materials selected and documented in the Emerson/Fisher serial card provided with this product.

**⚠ WARNING**

**Personal injury or damage to equipment could occur if improper stud and nut materials or parts are used. Do not operate or assemble this product with stud(s) and nut(s) that are not approved by Emerson/Fisher engineering and/or listed on the serial card provided with this product. Use of unapproved materials and parts could lead to stresses exceeding the design or code limits intended for this particular service. Install studs with the material grade and manufacturer's identification mark visible. Contact your [Emerson sales office](#) immediately if a discrepancy between actual parts and approved parts is suspected.**

13. Lubricate the stud threads, the faces of the hex nuts (key 14), and washers (key 40) (if provided) with anti-seize lubricant (not necessary if new factory prelubricated hex nuts are used). Replace the hex nuts, but do not tighten them. Torque the nuts in a crisscross pattern to no more than 1/4 of the nominal torque value specified in Table 7. When all nuts are tightened to that torque value, increase the torque by 1/4 of the specified nominal torque and repeat the crisscross pattern. Repeat this procedure until all nuts are tightened to the specified nominal value. Apply the final torque value again and, if any nut still turns, tighten every nut again.
14. Install new packing and packing box parts per steps 15 and 16 of the Replacing Packing procedure. Be certain to observe the note given prior to step 15 of that procedure.
15. Mount the actuator by following the procedures in the actuator instruction manual. Check for packing leakage as the valve is being put into service. Retorque the packing flange nuts as required (see Table 6).

## NPS 3 to 6 HPD (Short), HPT (Short), HPS (Short) and NPS 6 and 8 CL2500 HPAD, HPAT (Figures 34, 35, 36 and 37)

1. Install the seat ring flat sheet gasket (key 12) in the lower gasket groove in the valve body (key 1), making sure the gasket is centered in the groove and the bottom of the gasket is flush with the mating surface in the body.
2. Install the seat ring (key 4) on top of the gasket in the body.
3. Install the cage (key 2) on top of the seat ring.
4. If applicable, install the backup ring (key 9) on cage groove.
5. For HPT constructions, slip quantity-1 seal ring (key 42) into the cage retainer (key 45) with the open side of the seal ring facing the top or bottom of the seat ring, depending on flow direction. For flow up the seal will need to be oriented with the opening toward the bonnet side of the retainer; for flow down the seal opening needs to be facing toward the cage side of the retainer. Make sure the anti-extrusion ring is on the closed side of the seal ring (see Figure 34).

---

### NOTE

The anti-extrusion ring is NOT reversible. There is a flat face side and angle side. The angle face sides must be installed mating to each other. The seal will not function properly if it is not assembled correctly. The seal installation should be done prior to cage retainer installation into the valve. To hold the anti-extrusion ring in while lowering the cage, a dollop of grease can be used.

---

6. Install the cage retainer (key 45) on top of the cage.
7. For HPD and HPT constructions, install piston rings (key 39) into the grooves on the plug (key 6).

---

### NOTE

If it is necessary to install new piston rings, the replacement piston rings will arrive in one piece. Use a vise with smooth or taped jaws to break a replacement piston ring into halves. Place the new ring in the vise so that the jaws compress the ring into an oval. Compress the ring slowly until the ring snaps on both sides. If one side snaps first, do not try to tear or cut the other side. Instead, keep compressing until the other side snaps. The piston ring can also be fractured by scoring and snapping over a hard surface such as a table edge. Sawing or cutting is not recommended.

---

8. Install the plug (key 6) into the assembly through the cage retainer. Lower until it contacts the seat.
9. Install quantity-2 spiral wound gaskets onto the gasket groove on the cage retainer.
10. Install the bonnet gasket (key 11) into the groove around the valve body trim opening.
11. Lower the bonnet (key 18) over the valve plug stem, ensuring the valve stem is centered with the bonnet. This is important so that the top of the stem will engage the packing bore hole in the bonnet. Continue to lower the bonnet over the cage retainer.

---

**NOTE**

Be careful to prevent the bonnet from crushing the spiral wound gaskets as the bonnet is lowered on to the valve. Damaging the gaskets will require that they are replaced.

The prelubricated hex nuts (key 14) referred to in step 12 can be identified by a black film coating on the nut threads.

The proper bolting procedures in step 12 include--but are not limited to--ensuring that the bonnet stud threads are clean and that the hex nuts are evenly tightened to the specified torque values.

Tapped holes are provided in the cage and cage retainer as lifting provisions should they be needed for installation.

Contact your [Emerson sales office](#) for additional information.

---

** WARNING**

**Personal injury or damage to equipment could occur if improper stud and nut materials or parts are used. Do not operate or assemble this product with stud(s) and nut(s) that are not approved by Emerson/Fisher engineering and/or listed on the serial card provided with this product. Use of unapproved materials and parts could lead to stresses exceeding the design or code limits intended for this particular service. Install studs with the material grade and manufacturer's identification mark visible. Contact your [Emerson sales office](#) immediately if a discrepancy between actual parts and approved parts is suspected.**

---

**NOTICE**

**Failure to comply with good bonnet-to-body bolting practices and the torque values shown in Table 7 may result in damage to the valve. Cheater bars or slug wrenches should not be used for this procedure. Hot torquing is not recommended.**

---

**NOTE**

Stud(s) and nut(s) should be installed such that the manufacturer's trademark and material grade marking is visible, allowing easy comparison to the materials selected and documented in the Emerson/Fisher serial card provided with this product.

---

12. Lubricate the stud threads, the faces of the hex nuts (key 14) and washers (key 40) (if provided) with anti-seize lubricant (not necessary if new factory prelubricated hex nuts are used). Replace the hex nuts, but do not tighten them. Torque the nuts in a crisscross pattern to no more than 1/4 of the nominal torque value specified in Table 9. When all nuts are tightened to that torque value, increase the torque by 1/4 of the specified nominal torque and repeat the crisscross pattern. Repeat this procedure until all nuts are tightened to the specified nominal value. Apply the final torque value again and, if any nut still turns, tighten every nut again.
13. Install new packing and packing box parts per steps 15 and 16 of the Replacing Packing procedure. Be certain to observe the note given prior to step 15 of that procedure.
14. Mount the actuator by following the procedures in the actuator instruction manual. Check for packing leakage as the valve is being put into service. Retorque the packing flange nuts as required (see Table 6).

## 3.7 Retrofit: Installing C-seal Trim

Apply to NPS 2 to 6 HPD (Long), HPT (Long) and NPS 2 to 8 CL1500 HPAD and HPAT Constructions

### NOTE

Additional actuator thrust is required for a valve with C-seal trim. When installing C-seal trim in an existing valve, contact your [Emerson sales office](#) for assistance in determining new actuator thrust requirements.

Assemble the new valve plug/retainer assembly (with C-seal plug seal) using the following instructions:

### NOTICE

**To avoid leakage when the valve is returned to service, use appropriate methods and materials to protect all sealing surfaces of the new trim parts while assembling the individual parts and during installation in the valve body.**

1. Apply a suitable high-temperature lubricant to the inside diameter of the C-seal plug seal. Also, lubricate the outside diameter of the valve plug where the C-seal plug seal must be pressed into the proper sealing position (Figure 13).
2. Orient the C-seal plug seal for correct sealing action based on the process fluid flow direction through the valve.
  - The open interior of the C-seal plug seal must face up in a valve with flow-up construction (Figure 13).
  - The open interior of the C-seal plug seal must face down in a valve with flow-down construction (Figure 13).

### NOTE

An installation tool must be used to properly position the C-seal plug seal on the valve plug. A tool is available as a Fisher spare part or a tool could be manufactured following the dimensions given in Figure 14.

3. Place the C-seal plug seal over the top of the valve plug and press the C-seal plug seal onto the plug using the C-seal installation tool. Carefully press the C-seal plug seal onto the plug until the installation tool contacts the horizontal reference surface of the valve plug (Figure 15).
4. Apply a suitable high-temperature lubricant to the threads on the plug. Then, place the C-seal retainer onto the plug and tighten the retainer using an appropriate tool such as a strap wrench.
5. Using an appropriate tool such as a center punch, stake the threads on top of the plug in one place (Figure 16) to secure the C-seal retainer.
6. Install the new plug/retainer assembly with C-seal plug seal on the new stem following the appropriate instructions in the Trim Replacement section in this manual.
7. Install piston rings by following instructions in the Trim Replacement section in this manual.
8. Remove the existing valve actuator and bonnet following the appropriate instructions in the Replacing Packing section in this manual.

Figure 13. HPD with C-seal Trim

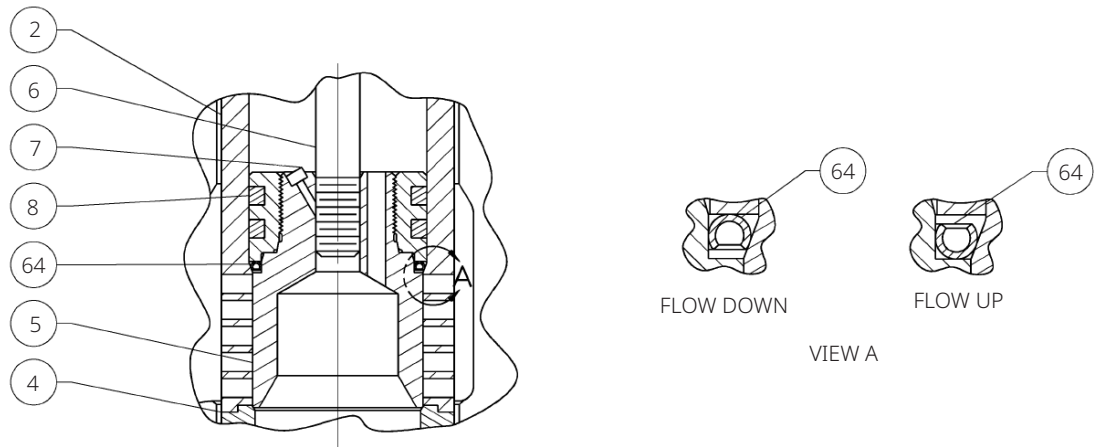

37B1399-A

Figure 14. C-seal Plug Seal Installation Tool

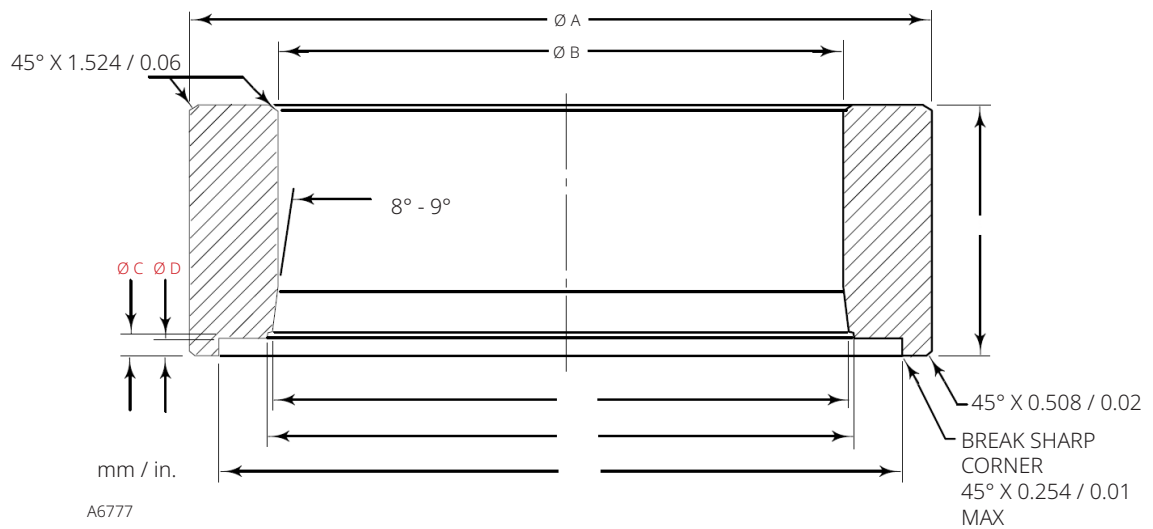

FOR VALVE PLUGS FITTING PORT SIZE, In.	DIMENSIONS, mm (See Figure 14)								Part Number (To Order A Tool)
	A	B	C	D	E	F	G	H	
2.875	82.55	52.324 to 52.578	4.978 to 5.029	3.708 to 3.759	41.148	52.680 to 52.781	55.118 to 55.626	70.891 to 71.044	24B9816X012
3.4375	101.6	58.674 to 58.928	4.978 to 5.029	3.708 to 3.759	50.8	61.011 to 61.112	63.449 to 63.957	85.166 to 85.319	24B5612X012
3.625	104.394	65.024 to 65.278	4.978 to 5.029	3.708 to 3.759	50.8	68.936 to 69.037	71.374 to 71.882	89.941 to 90.094	24B3630X012
4.375	125.984	83.439 to 83.693	4.978 to 5.029	3.708 to 3.759	50.8	87.351 to 87.452	89.789 to 90.297	108.991 to 109.144	24B3635X012
5.375	142.748	100.076 to 100.33	4.978 to 5.029	3.708 to 3.759	45.974	103.835 to 103.937	106.274 to 106.782	128.219 to 128.372	23B9193X012
FOR VALVE PLUGS FITTING PORT SIZE, In.	DIMENSIONS, in. (See Figure 14)								Part Number (To Order A Tool)
	A	B	C	D	E	F	G	H	
2.875	3.25	2.060 to 2.070	0.196 to 0.198	0.146 to 0.148	1.62	2.074 to 2.078	2.170 to 2.190	2.791 to 2.797	24B9816X012
3.4375	4.00	2.310 to 2.320	0.196 to 0.198	0.146 to 0.148	2.00	2.402 to 2.406	2.498 to 2.518	3.353 to 3.359	24B5612X012
3.625	4.11	2.560 to 2.570	0.196 to 0.198	0.146 to 0.148	2.00	2.714 to 2.718	2.810 to 2.830	3.541 to 3.547	24B3630X012
4.375	4.96	3.285 to 3.295	0.196 to 0.198	0.146 to 0.148	2.00	3.439 to 3.443	3.535 to 3.555	4.291 to 4.297	24B3635X012
5.375	5.62	3.940 to 3.950	0.196 to 0.198	0.146 to 0.148	1.81	4.088 to 4.092	4.184 to 4.204	5.048 to 5.054	23B9193X012

**NOTICE**

Do not remove the existing valve stem from the valve plug unless you are planning to replace the valve stem.

Never reuse an old valve stem with a new plug or reinstall a valve stem after it has been removed. Replacing a valve stem requires drilling a new pin hole in the stem. This drilling weakens the stem and may cause failure in service. However, a used valve plug may be reused with a new valve stem.

9. Remove the existing valve stem and plug, cage and seat ring from the valve body following the appropriate instructions in the Trim Removal section in this manual.
10. Replace all gaskets according to appropriate instructions in the Trim Replacement section in this manual.
11. Install the new seat ring, cage, valve plug/retainer assembly and stem into the valve body and completely reassemble the valve package following the appropriate instructions in the Trim Replacement section in this manual.

**Figure 15. Installing the C-seal Plug Seal Using the Installation Tool**

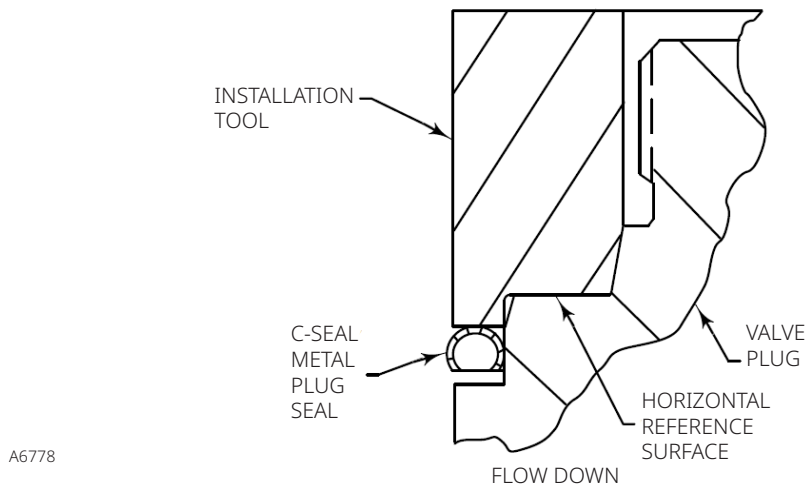

NOTE:  
PRESS THE INSTALLATION TOOL OVER THE VALVE PLUG UNTIL THE TOOL CONTACTS THE HORIZONTAL REFERENCE SURFACE OF THE VALVE PLUG.

**Figure 16. Stake the Threads of the C-seal Retainer**

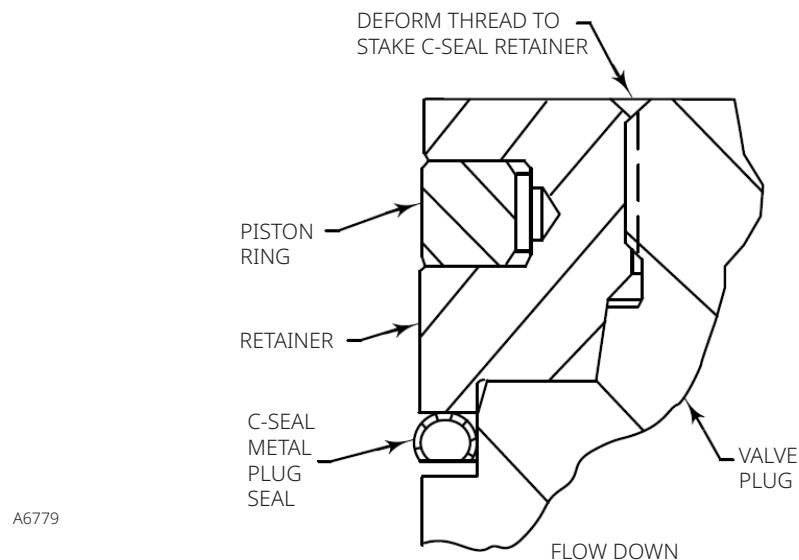

**NOTICE**

To avoid excessive leakage and seat erosion, the valve plug must be initially seated with sufficient force to overcome the resistance of the C-seal plug seal and contact the seat ring. You can correctly seat the valve plug by using the same force calculated for full load when sizing your actuator. With no pressure drop through the valve, this force will adequately drive the valve plug to the seat ring, thus giving the C-seal plug seal a predetermined permanent set. Once this is done, the plug/retainer assembly, the cage and the seat ring become a matched set.

12. With full actuator force applied and the valve plug fully seated, align the actuator travel indicator scale with the lower end of valve travel. Refer to the appropriate actuator instruction manual for information on this procedure.

### 3.8 Replacement of Installed C-seal Trim

Apply to NPS 2 to 6 HPD (Long), HPT (Long) and NPS 2 to 8 HPAD (Long) and HPAT (Long) Constructions

#### Trim Removal (C-seal Constructions)

1. Remove the valve actuator and bonnet following the appropriate instructions in the Replacing Packing section in this manual.

**NOTICE**

To avoid leakage when the valve is returned to service, use appropriate methods and materials to protect all sealing surfaces of the trim parts during maintenance.

Use caution when removing piston ring(s) and C-seal plug seal to avoid scratching any sealing surface.

**NOTICE**

Do not remove the valve stem from the plug/retainer assembly unless you are planning to replace the valve stem.

Never reuse an old valve stem with a new plug or reinstall a valve stem after it has been removed. Replacing a valve stem requires drilling a new pin hole in the stem. This drilling weakens the stem and may cause failure in service. However, a used valve plug may be reused with a new valve stem.

2. Remove the plug/retainer assembly (with C-seal plug seal), cage and seat ring from the valve body following the appropriate instructions in the Trim Removal section in this manual.
3. Locate the staked thread on top of the valve plug (Figure 16). The staked thread secures the retainer. Use a drill with a 1/8 inch bit to drill out the staked area of the thread. Drill approximately 1/8-in. into the metal to remove the staking.
4. Locate the break between sections of the piston ring(s). Using an appropriate tool such as a flat-blade screwdriver, carefully pry out the piston ring(s) from the groove(s) in the C-seal retainer.
5. After removing the piston ring(s), locate the 1/4-inch diameter hole in the groove. In a retainer with two piston ring grooves, the hole will be found in the upper groove.
6. Select an appropriate tool such as a punch and place the tip of the tool into the hole with the body of the tool held tangent to the outside diameter of the retainer. Strike the tool with a hammer to rotate the retainer and free it from the valve plug. Remove the retainer from the plug.
7. Use an appropriate tool such as a flat-blade screwdriver to pry the C-seal plug seal off the plug. Use caution to avoid scratches or other damage to the sealing surfaces where the C-seal plug seal makes contact with the valve plug (Figure 17).
8. Inspect the lower seating surface where the valve plug contacts the seat ring for wear or damage which would prevent proper operation of the valve. Also, inspect the upper seating surface inside the cage where the C-seal plug seal contacts the cage and inspect the sealing surface where the C-seal plug seal makes contact with the plug (Figure 17).
9. Replace or repair trim parts according to the following procedure for Lapping Metal Seats, Remachining Metal Seats or other valve plug maintenance procedures as appropriate.

## Lapping Metal Seats (C-seal Constructions)

Before installing a new C-seal plug seal, lap the lower seating surface (valve plug to seat ring, Figure 17) following appropriate procedures in the Lapping Seats section in this manual.

## Remachining Metal Seats (C-seal Constructions)

See Figure 18. A valve plug with a C-seal metal plug seal features two seating surfaces. One seating surface is found where the valve plug contacts the seat ring. The second seating surface is found where the C-seal plug seal contacts the upper seating surface in the cage. If you machine the seats on the seat ring and/or plug, you must machine an equal dimension from the seating area in the cage.

### **NOTICE**

**If metal is removed from the seat ring and plug and a corresponding amount is not removed from the cage seating area, the C-seal plug seal will be crushed as the valve closes and the C-seal retainer will strike the seating area of the cage, preventing the valve from closing.**

**Figure 17. Lower (Valve Plug to Seat Ring) and Upper (C-seal Plug Seal to Cage) Seating Surfaces**

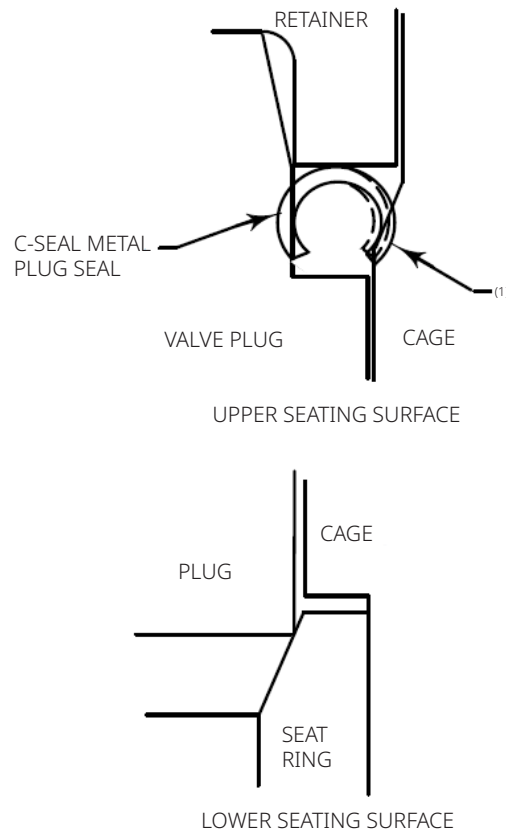

A6780

## NOTE:

1. UPPER SEATING SURFACE IS THE AREA OF CONTACT BETWEEN THE C-seal METAL PLUG SEAL AND THE CAGE.

## Trim Replacement (C-seal Constructions)

1. Apply a suitable high-temperature lubricant to the inside diameter of the C-seal plug seal. Also, lubricate the outside diameter of the valve plug where the C-seal plug seal must be pressed into the proper sealing position (Figure 13).
2. Orient the C-seal plug seal for correct sealing action based on the process fluid flow direction through the valve.
  - The open interior of the C-seal plug seal must face up in a valve with flow-up construction (Figure 13).
  - The open interior of the C-seal plug seal must face down in a valve with flow-down construction (Figure 13).

**NOTE**

An installation tool must be used to properly position the C-seal plug seal on the valve plug. A tool is available as a Fisher spare part or a tool could be manufactured following the dimensions given in Figure 14.

3. Place the C-seal plug seal over the top of the valve plug and press it onto the plug using the installation tool. Carefully press the C-seal plug seal onto the plug until the installation tool contacts the horizontal reference surface of the valve plug (Figure 15).
4. Apply a suitable high-temperature lubricant to the threads on the plug. Then, place the C-seal retainer onto the plug and tighten the retainer using an appropriate tool such as a strap wrench.

**Figure 18. Example of Machining the Lower (Valve Plug to Seat Ring) and Upper (C-seal Plug Seal to Cage) Seating Surfaces**

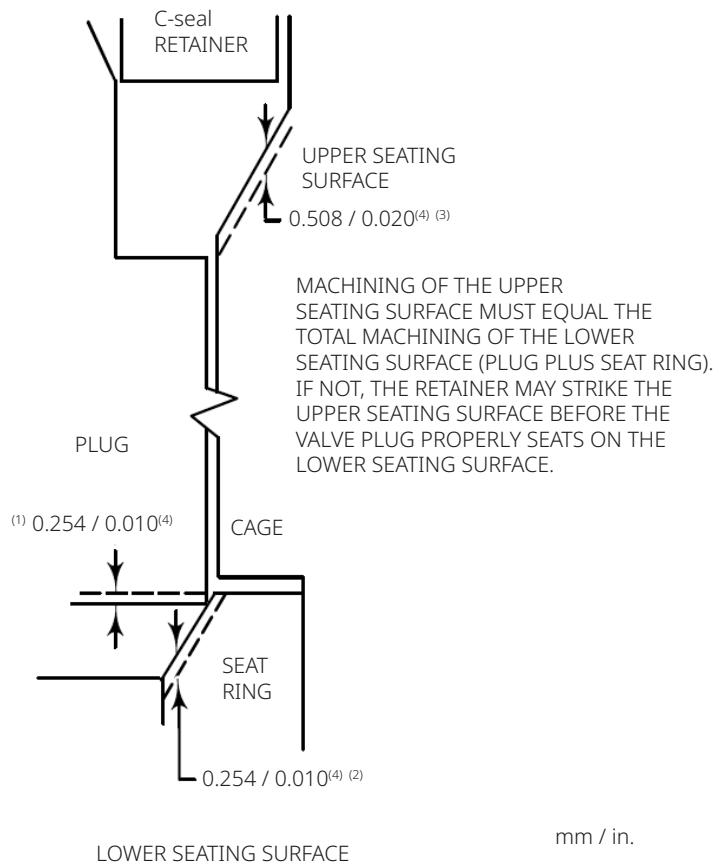

REMOVAL OF 0.010 IN. FROM THE SEAT RING

- NOTE:
1. REMOVAL OF 0.254 mm / 0.010 in. FROM THE VALVE PLUG
  - PLUS 2. REMOVAL OF 0.254 mm / 0.010 in. FROM THE SEAT RING
  - MUST EQUAL 3. REMOVAL OF 0.508 mm / 0.020 in. FROM THE UPPER SEATING SURFACE IN THE CAGE
  4. THESE VALUES ARE FOR EXAMPLE ONLY. REMOVE ONLY THE MINIMUM AMOUNT OF MATERIAL REQUIRED TO REFURBISH THE SEATS.

5. Using an appropriate tool such as a center punch, stake the threads on top of the plug in one place (Figure 16) to secure the C-seal retainer.
6. Replace the piston rings following instructions in the Trim Replacement section in this manual.
7. Return the seat ring, cage, plug/retainer assembly and stem to the valve body and completely reassemble the valve package following the appropriate instructions in the Trim Replacement section in this manual.

### NOTICE

**To avoid excessive leakage and seat erosion, the valve plug must be initially seated with sufficient force to overcome the resistance of the C-seal plug seal and contact the seat ring. You can correctly seat the valve plug by using the same force calculated for full load when sizing your actuator. With no pressure drop through the valve, this force will adequately drive the valve plug to the seat ring, thus giving the C-seal plug seal a predetermined permanent set. Once this is done, the plug/retainer assembly, the cage and the seat ring become a matched set.**

8. With full actuator force applied and the valve plug fully seated, align the actuator travel indicator scale with the lower end of valve travel. Refer to the appropriate actuator instruction manual for information on this procedure.

## 3.9 Replacement of Installed Bore Seal Trim

Apply to NPS 8 to 14 HPD, HPT and NPS 12 HPAD

### Trim Removal (Bore Seal Constructions)

1. Remove the valve actuator and bonnet following the appropriate instructions in the Replacing Packing section in this manual.

### NOTICE

**To avoid leakage when the valve is returned to service, use appropriate methods and materials to protect all sealing surfaces of the trim parts during maintenance.**

**Use caution when removing piston ring(s) and bore seal plug seal to avoid scratching any sealing surface.**

### NOTICE

**Do not remove the valve stem from the plug/retainer assembly unless you are planning to replace the valve stem.**

**Never reuse an old valve stem with a new plug or reinstall a valve stem after it has been removed. Replacing a valve stem requires drilling a new pin hole in the stem. This drilling weakens the stem and may cause failure in service. However, a used valve plug may be reused with a new valve stem.**

2. Remove the plug assembly, cage retainer (key 45) (as required) and cage (key 5) (with bore seal) from the valve body following the appropriate instructions in the Trim Removal section in this manual.
3. Remove the piston rings from the grooves on plug.
4. Remove cage gaskets (key 43) and discard.
5. Inspect the lower seating surface where the valve plug contacts the seat ring for wear or damage which would prevent proper operation of the valve.
6. Replace or repair trim parts according to the following procedure of valve plug maintenance procedures as appropriate.

### Trim Replacement (Bore Seal Constructions)

1. Unless the order does not allow lubrication in contact with the process media, apply a suitable high-temperature lubricant to the outside diameter of the bore seal (key 42). Also, lubricate the inside diameter of the cage where the bore seal must be pressed into the proper sealing position.
2. Orient the bore seal (key 42) for correct sealing action based on the process fluid flow direction through the valve.
  - The open interior of the bore seal must face up in a valve with flow-up construction (Figure 19).
  - The open interior of the bore seal must face down in a valve with flow-down construction (Figure 20).

**Figure 19. Bore Seal Installed Orientation**

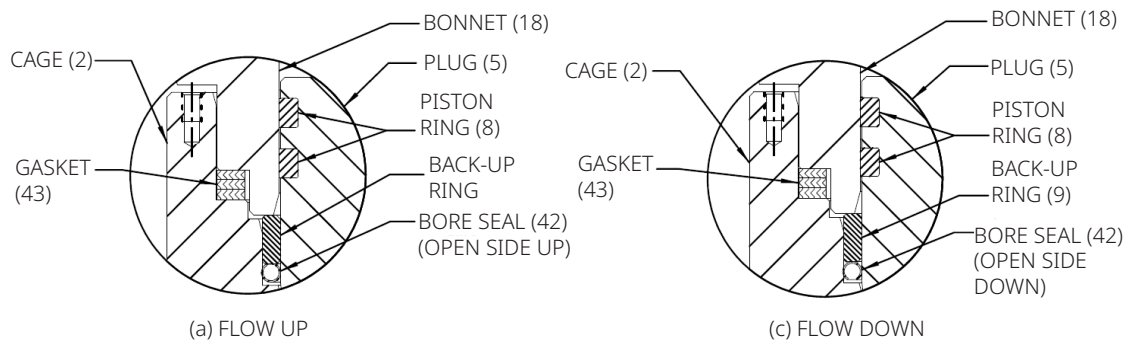

3. Place the bore seal (key 42) at the top of the seal groove in cage. The seal will not fit completely into the groove with hand force alone. Forcing the seal in by hand may damage the seal.

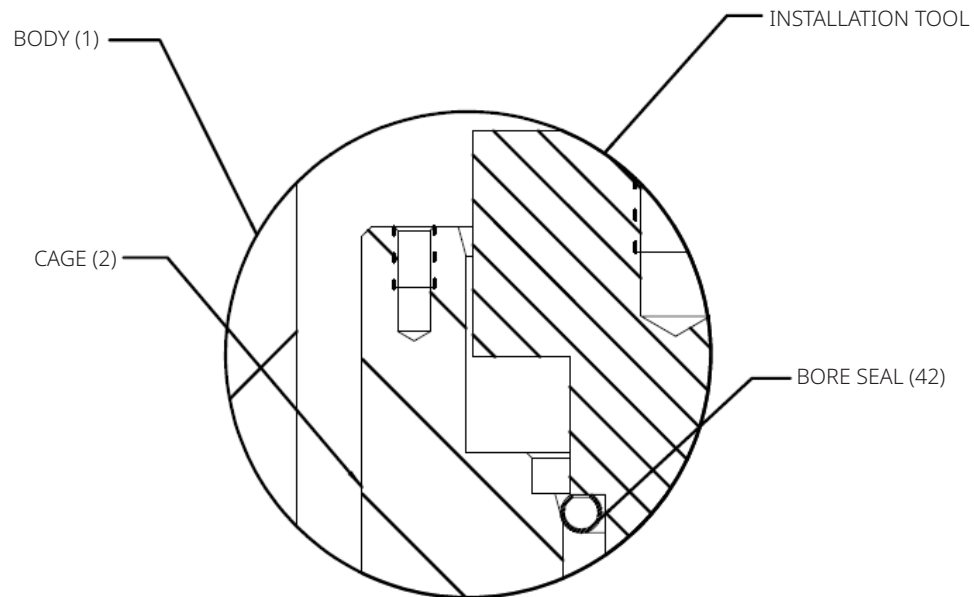
**Figure 20. Bore Seal Installation with Tool**

4. Use the installation tool to help press the seal ring evenly on to the cage and make sure the seal ring is centered until the installation tool and cage come to metal-to-metal. See Figure 22 for tool dimensions and part numbers.
5. Place the backup ring (key 9) into the seal groove until it touches the seal ring (key 42).
6. Install the new cage, gaskets, valve plug/stem assembly and bonnet into the valve body and completely reassemble the valve package following the appropriate instructions in the Trim Replacement section in this manual.

### **NOTICE**

**To avoid excessive leakage and seat erosion, the valve plug must be initially seated with sufficient force to overcome the resistance of the bore seal plug seal and contact the seat ring. You can correctly seat the valve plug by using the same force calculated for full load when sizing your actuator. With no pressure drop through the valve, this force will adequately drive the valve plug to the seat ring, thus giving the bore seal a predetermined permanent set. Once this is done, the plug assembly, the cage and the seat ring become a matched set.**

7. With full actuator force applied and the valve plug fully seated, align the actuator travel indicator scale with the lower end of valve travel. Refer to the appropriate actuator instruction manual for information on this procedure.

**Figure 21. Bore Seal Installation Tool**

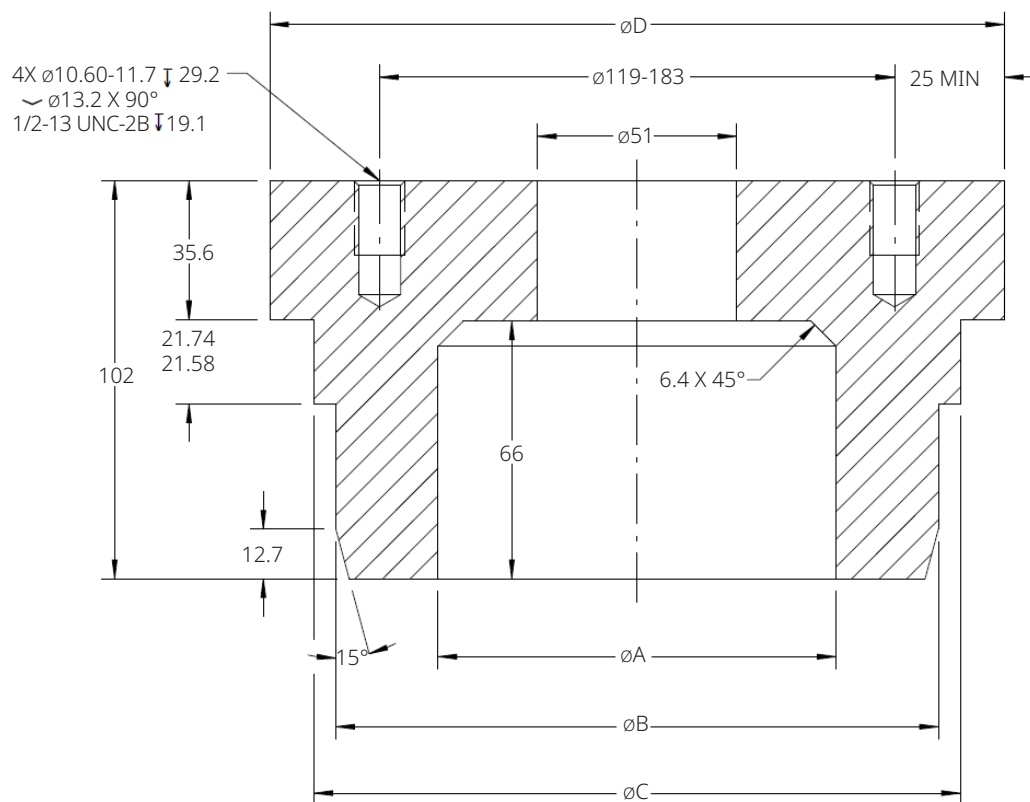

GE97620

PORT SIZE, In.	DIMENSIONS, mm (See Figure 21)				Part Number (To Order A Tool)
	A	B	C	D	
5.5	89.0	141.68 to 141.78	152.75 to 153.25	179.72 to 180.22	GE96935X012
6	102.0	154.38 to 154.48	165.45 to 165.95	181.10 to 181.60	GE96941X012
6.5	114.0	167.08 to 167.18	178.15 to 178.65	208.68 to 209.18	GE96910X012
7	127.0	179.78 to 179.88	190.85 to 191.35	219.12 to 219.62	GE96919X012
7.5	140.0	192.48 to 192.58	203.55 to 204.05	232.55 to 233.05	GE95212X012
8	152.0	205.18 to 205.28	216.25 to 216.75	239.00 to 239.50	GE96879X012
8.5	167	218.11 to 218.01	229.46 to 228.96	261.36 to 260.86	GEH08051X012

- continued -

PORT SIZE, in.	DIMENSIONS, in. (See Figure 21)				Part Number (To Order A Tool)
	A	B	C	D	
5.5	3.50	5.578 to 5.582	6.014 to 6.033	7.076 to 7.095	GE96935X012
6	4.02	6.078 to 6.082	6.514 to 6.533	7.406 to 7.425	GE96941X012
6.5	4.49	6.578 to 6.582	7.014 to 7.033	8.216 to 8.235	GE96910X012
7	5.00	7.078 to 7.082	7.514 to 7.533	8.627 to 8.646	GE96919X012
7.5	5.51	7.578 to 7.582	8.014 to 8.033	9.156 to 9.175	GE95212X012
8	5.984	8.078 to 8.082	8.514 to 8.533	9.409 to 9.429	GE96879X012
8.5	6.57	8.583 to 8.587	9.014 to 9.034	10.270 to 10.290	GH08051X012

## Section 4: Parts Ordering

Each body-bonnet assembly is assigned a serial number, which can be found on the valve body. This same number also appears on the actuator nameplate when the valve body is shipped from the factory as part of a control valve assembly. Refer to the number when contacting your [Emerson sales office](#) for technical assistance or when ordering replacement parts.

### WARNING

**Use only genuine Fisher replacement parts. Components that are not supplied by Emerson should not, under any circumstances, be used in any Fisher valve, because they may void your warranty, might adversely affect the performance of the valve, and could cause personal injury and property damage.**

## Section 5: Parts Kits

### Standard Packing Kits (Non Live-Loaded)

Stem Diameter, mm/ in. Yoke Boss Diameter, mm / in.	12.7 / 1/2 71 / 2-13/16	19.1 / 3/4 90 / 3-9/16	25.4 / 1 127 / 5	31.8 / 1-1/4 127 / 5, 5H	50.8 / 2 178 / 7
PTFE (Contains keys 22, 24, 25, 26, 27)	RPACKX00022	RPACKX00032	RPACKX00342	RPACKX00352	Consult Sales Office
Double PTFE (Contains keys 22, 24, 26, 27)	RPACKX00052	RPACKX00062	RPACKX00362	RPACKX00372	Consult Sales Office
Single Graphite Ribbon/Filament (Contains keys 23 [ribbon ring], 23 [filament ring], 24 and 26)	RPACKX00112	RPACKX00122	---	---	Consult Sales Office
Single Graphite Ribbon/Filament (Contains keys 23 [ribbon ring], 23 [filament ring] and 26)	---	---	RPACKX00532	RPACKX00542	RPACKX00552
Single Graphite Ribbon/Filament (Contains keys 23 [ribbon ring], 23 [filament ring])	RPACKX00142	RPACKX00152	---	---	Consult Sales Office

Repair Kits (ENVIRO-SEAL)

Stem Diameter, mm/ in. Yoke Boss Diameter, mm / in.	12.7 / 1/2 71 / 2-13/16	19.1 / 3/4 90 / 3-9/16	25.4 / 1 127 / 5	31.8 / 1-1/4 127 / 5, 5H	50.8 / 2 178 / 7
Double PTFE (Contains keys 214, 215, 218)	RPACKX00202	RPACKX00212	RPACKX00222	RPACKX00232	Consult Sales Office
Graphite ULF (Contains keys 207, 208, 209, 210, 214)	RPACKX00602	RPACKX00612	RPACKX00622	RPACKX00632	Consult Sales Office
Duplex (Contains keys 207, 209, 214, 215)	RPACKX00302	RPACKX00312	RPACKX00322	RPACKX00332	Consult Sales Office

Retrofit Kits (ENVIRO-SEAL)

Stem Diameter, mm/ in. Yoke Boss Diameter, mm / in.	12.7 / 1/2 71 / 2-13/16	19.1 / 3/4 90 / 3-9/16	25.4 / 1 127 / 5	31.8 / 1-1/4 127 / 5, 5H	50.8 / 2 178 / 7
Double PTFE (Contains keys 200, 201, 211, 212, 214, 215, 216, 217, 218, tag, cable tie)	RPACKXRT022	RPACKXRT032	RPACKXRT042	RPACKXRT052	Consult Sales Office
Graphite ULF (Contains keys 200, 201, 207, 208, 209, 210, 211, 212, 214, 217, tag, cable tie)	RPACKXRT272	RPACKXRT282	RPACKXRT292	RPACKXRT302	Consult Sales Office
Duplex (Contains keys 200, 201, 207, 209, 211, 212, 214, 215, 216, 217, tag, cable tie)	RPACKXRT222	RPACKXRT232	RPACKXRT242	RPACKXRT252	Consult Sales Office

**Table 11. Gasket Set\* (Includes Key 11 Bonnet Gasket, Key 43 Cage Gasket and Key 12 Seat Ring Gasket)<sup>(1)</sup> NPS 3 to NPS 24 HPD (Short), HPT (Short) and CL2500 HPAD and HPAT**

VALVE RATING	VALVE STYLE AND SIZE, NPS		MATERIAL		
	HP Globe	HPA Angle	Bonnet Spiral Wound Gasket N06600/Graphite	Cage Spiral Wound Gasket N06600/Graphite	Seat Ring Flat Sheet Gasket S31600/Graphite
CL900	4 (short)	---	GG62142X012	GG62143X012	GG62144X012
	6 (short)	---	GG62162X012	GG62163X012	GG62164X012
	8 (short)	---	GG53667X012	GG53677X012	GG53849X012
	10 (short)	---	GG53684X012	GG53685X012	GG53852X012
	12 (short)	---	GG53692X012	GG53693X012	GG53854X012
	16	---	GG86318X012	GG86322X012	GG86323X012
	18	---	GG83736X012	GG83737X012	GG85745X012
	20	---	GG85746X012	GG85747X012	GG85748X012
	24	---	GG85749X012	GG85750X012	GG85751X012

- continued -

**Table 11. Gasket Set\* (Includes Key 11 Bonnet Gasket, Key 43 Cage Gasket and Key 12 Seat Ring Gasket)<sup>(1)</sup> NPS 3 to NPS 24 HPD (Short), HPT (Short) and CL2500 HPAD and HPAT (continued)**

VALVE RATING	VALVE STYLE AND SIZE, NPS		MATERIAL		
	HP Globe	HPA Angle	Bonnet Spiral Wound Gasket N06600/Graphite	Cage Spiral Wound Gasket N06600/Graphite	Seat Ring Flat Sheet Gasket S31600/Graphite
CL1500 <sup>(2)</sup>	4 (short)	---	GG62142X012	GG62143X012	GG62144X012
	6 (short)	---	GG62162X012	GG62163X012	GG62164X012
	8 (short)	---	GG53678X012	GG53679X012	GG53849X012
	10 (short)	---	GG53686X012	GG53687X012	GG53852X012
	12 (short)	---	GG53694X012	GG53695X012	GG53854X012
	16	---	GG86318X022	GG86322X022	GG86323X012
	18	---	GG83736X022	GG83737X022	GG85745X012
	20	---	GG85746X022	GG85747X022	GG85748X012
	24	---	GG85749X022	GG85750X022	GG85751X012
CL2500	3 (short)	---	GG62130X012	GG62131X012	GG62132X012
	4 (short)	6	GG62142X012	GG62143X012	GG62144X012
	6 (short)	8	GG62162X012	GG62163X012	GG62164X012
	8 (short)	---	GG53680X012	GG53681X012	GG53850X012
	10 (short)	12	GG53688X012	GG53689X012	GG53853X012
	12 (short)	---	GG53696X012	GG53697X012	GG53855X012
	14 (short)	---	GG62165X012	GG62169X012	GG62170X012
CL3200	8 (short)	---	GG53682X012	GG53683X012	GG53850X012
	10 (short)	---	GG53690X012	GG53691X012	GG53853X012
	12 (short)	---	GG53698X012	GG53699X012	GG53855X012

\* Recommended spare parts

1. Gaskets should always be replaced as sets, not separately.

2. Refer the serial card content to select the part number if it is hard to confirm the face-to-face information.

**Table 12. Gasket Set\* (Includes Key 11 Bonnet Gasket and Key 12 Seat Ring Gasket<sup>(1)</sup> NPS 1 to NPS 6 HPD (Long), HPT (Long) and NPS 1 to NPS 8 HPAD (Long) and HPAT (Long)**

VALVE RATING	VALVE STYLE AND SIZE, NPS		MATERIAL	
	HP Globe	HPA Angle	N06600/Graphite	N07750/Graphite
CL1500 Globe and Angle Valves	1 (std)	1 (std)	12B7100X012	12B7100X022
	2 (std)	2 (std) and 3 (std)	12B7100X032	12B7100X042
	2 (Cavitrol III, 2-Stage)	2 (Cavitrol III, 2-Stage)	12B7100X072	---
	3 (std)	4 (std)	12B7100X052	12B7100X062
	4 (std)	6 (std)	12B7100X082	---
	6 (std)	8 (std)	12B7100X112	---
CL2500 Globe and Angle Valves	1 (std)	1 (std)	12B7100X152	12B7100X122
	2 (std)	2 (std)	12B7100X162	12B7100X132
	2 (Cavitrol III, 2-Stage)	2 (Cavitrol III, 2-Stage)	12B7100X172	12B7100X142

\*Recommended spare parts  
1. Gaskets should always be replaced as sets, not separately.

**Figure 22. NPS 1 HPS Valve**

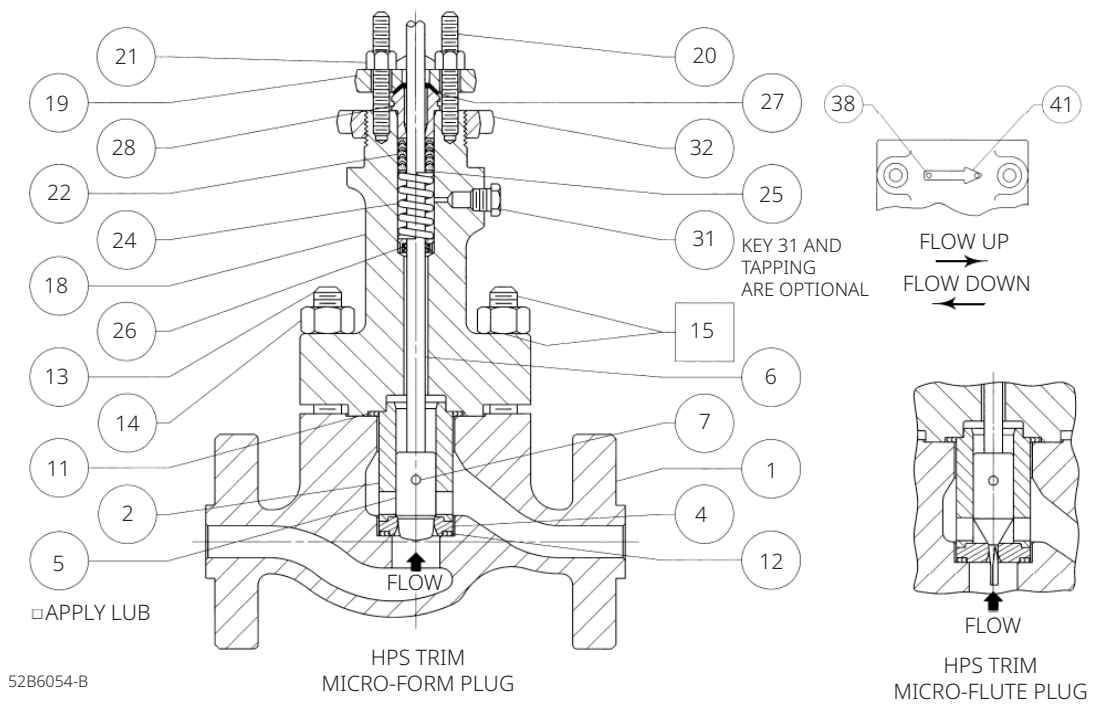

52B6054-B

Figure 23. NPS 2 HPAD Valve

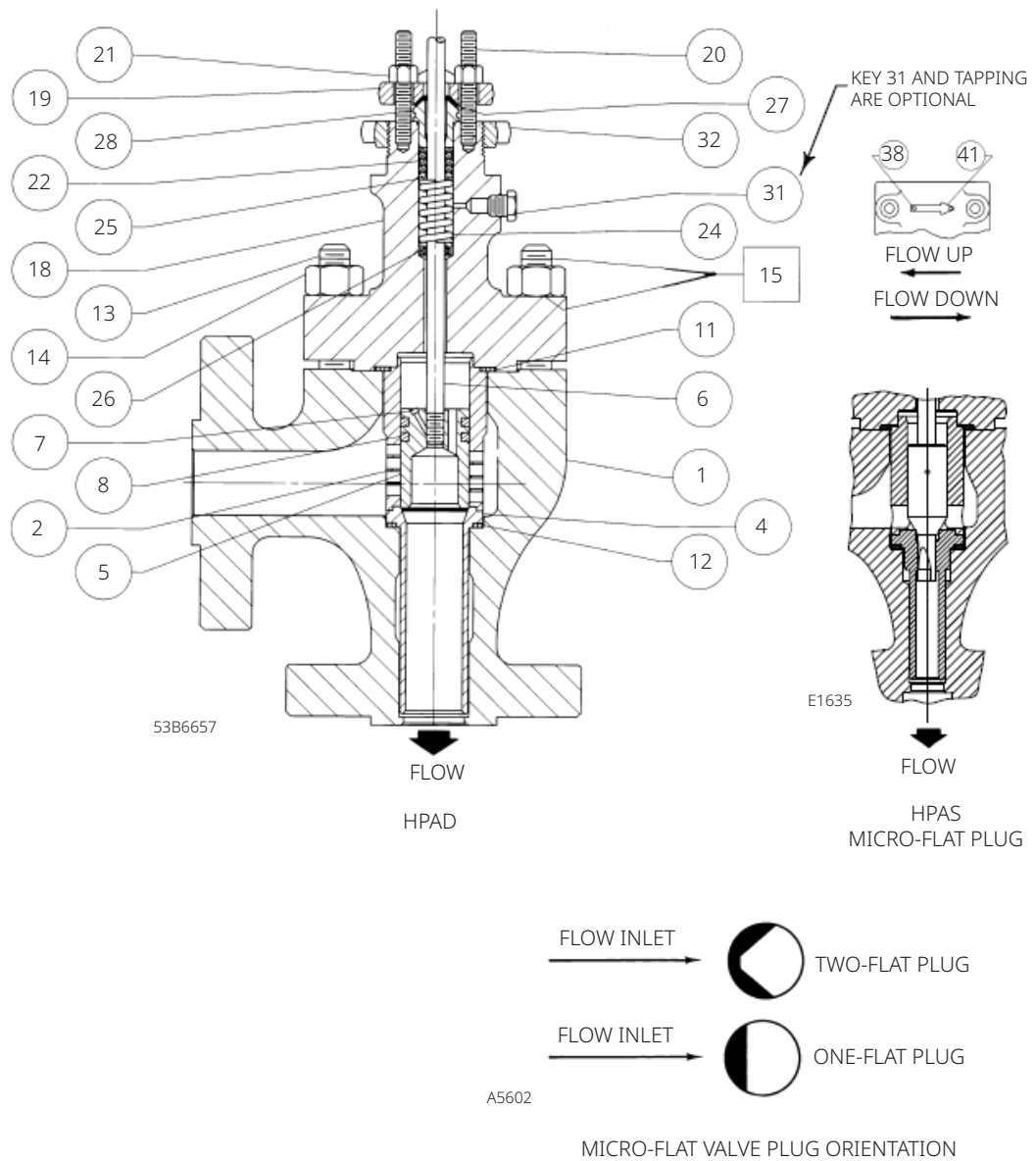
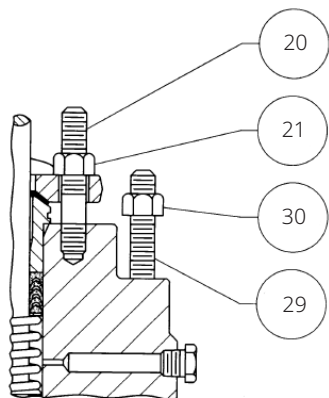
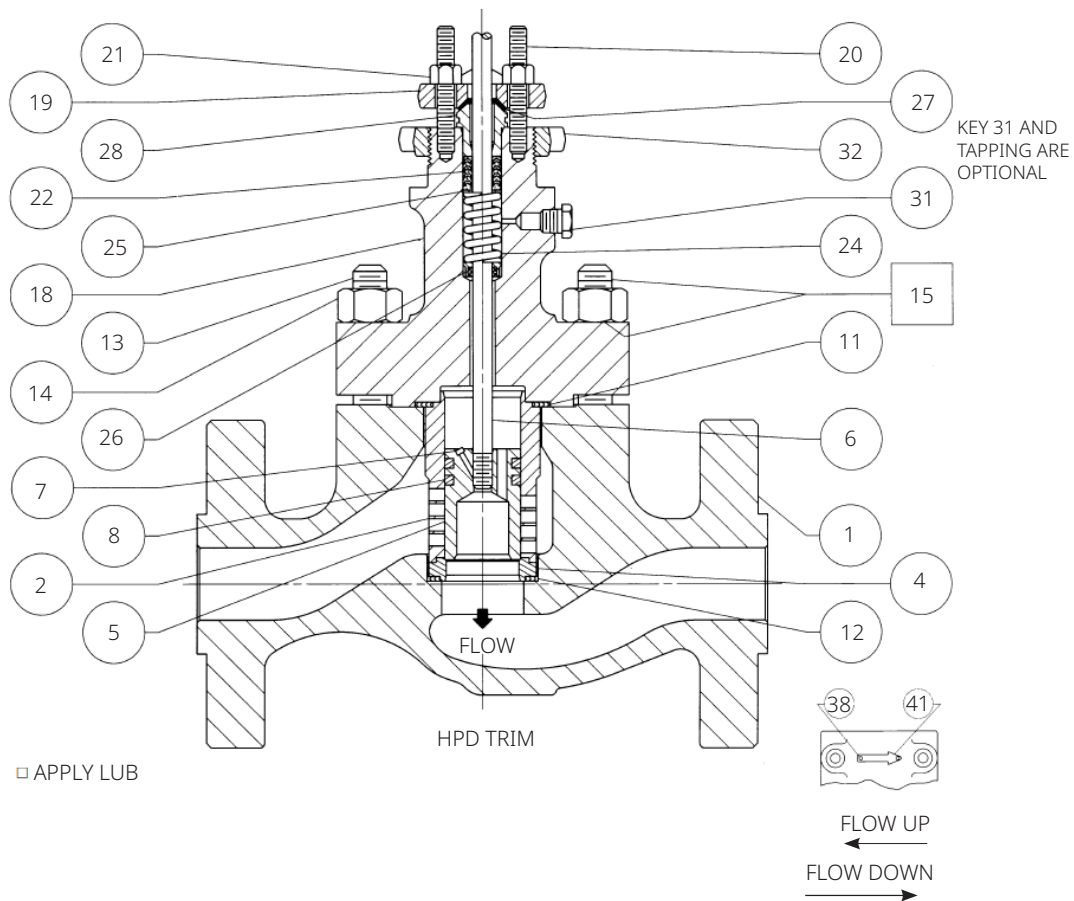
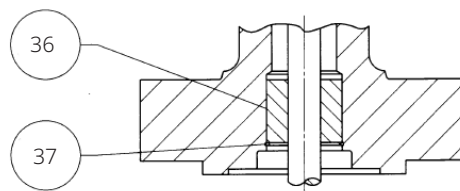

Figure 24. NPS 2 through 6 HPD (Long) Valve



127 mm / 5-IN. YOKE BOSS  
(GLOBE AND ANGLE)



EXTENSION BONNET BAFFLE ASSEMBLY  
(NPS 2 ONLY) (GLOBE AND ANGLE)

52B6045-C

Figure 25. NPS 2 through 6 HP (Long) Valve - Alternate Configurations

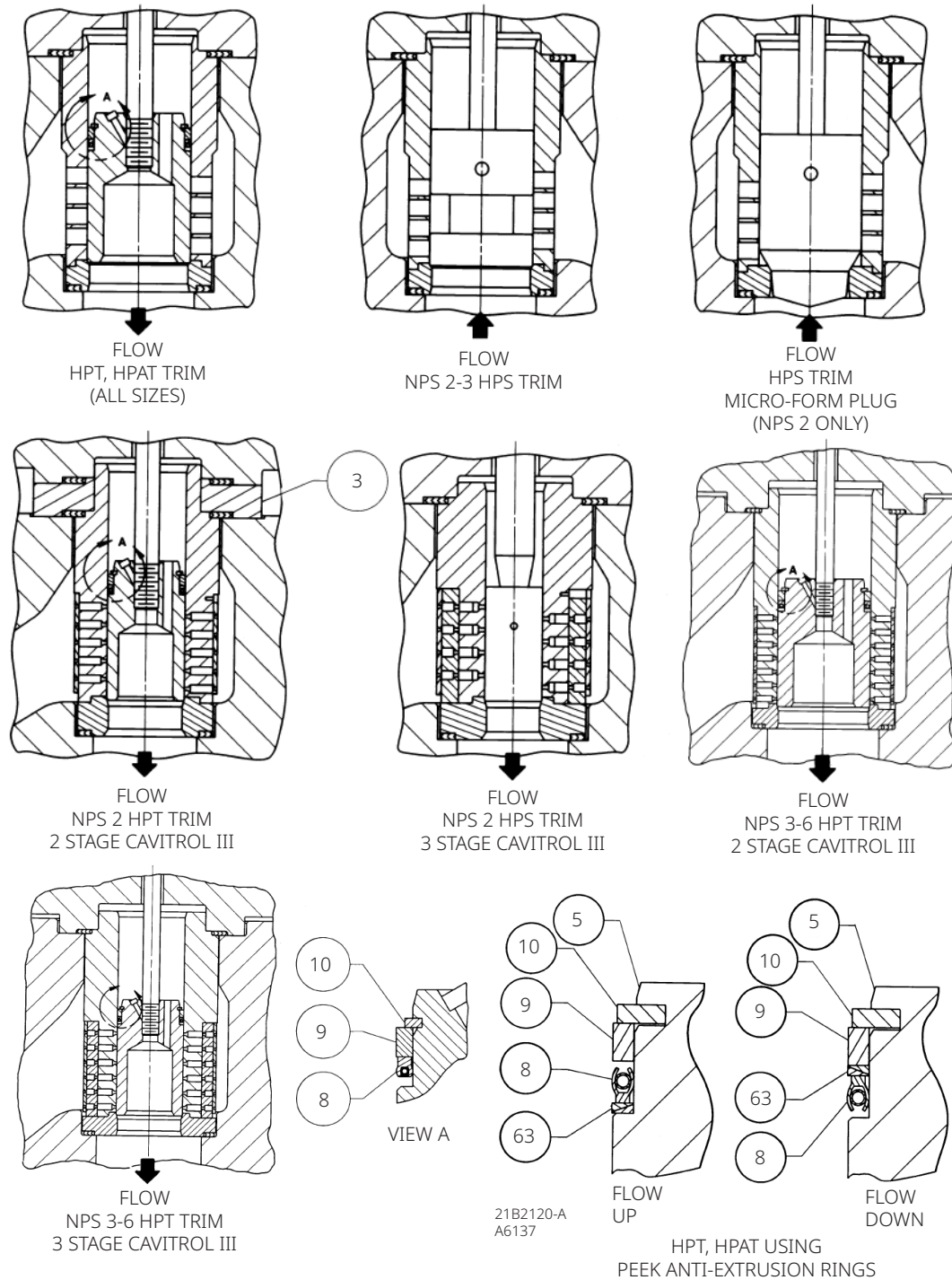

52B6045-C

Figure 25. NPS 2 through 6 HP (Long) Valve - Alternate Configurations (continued)

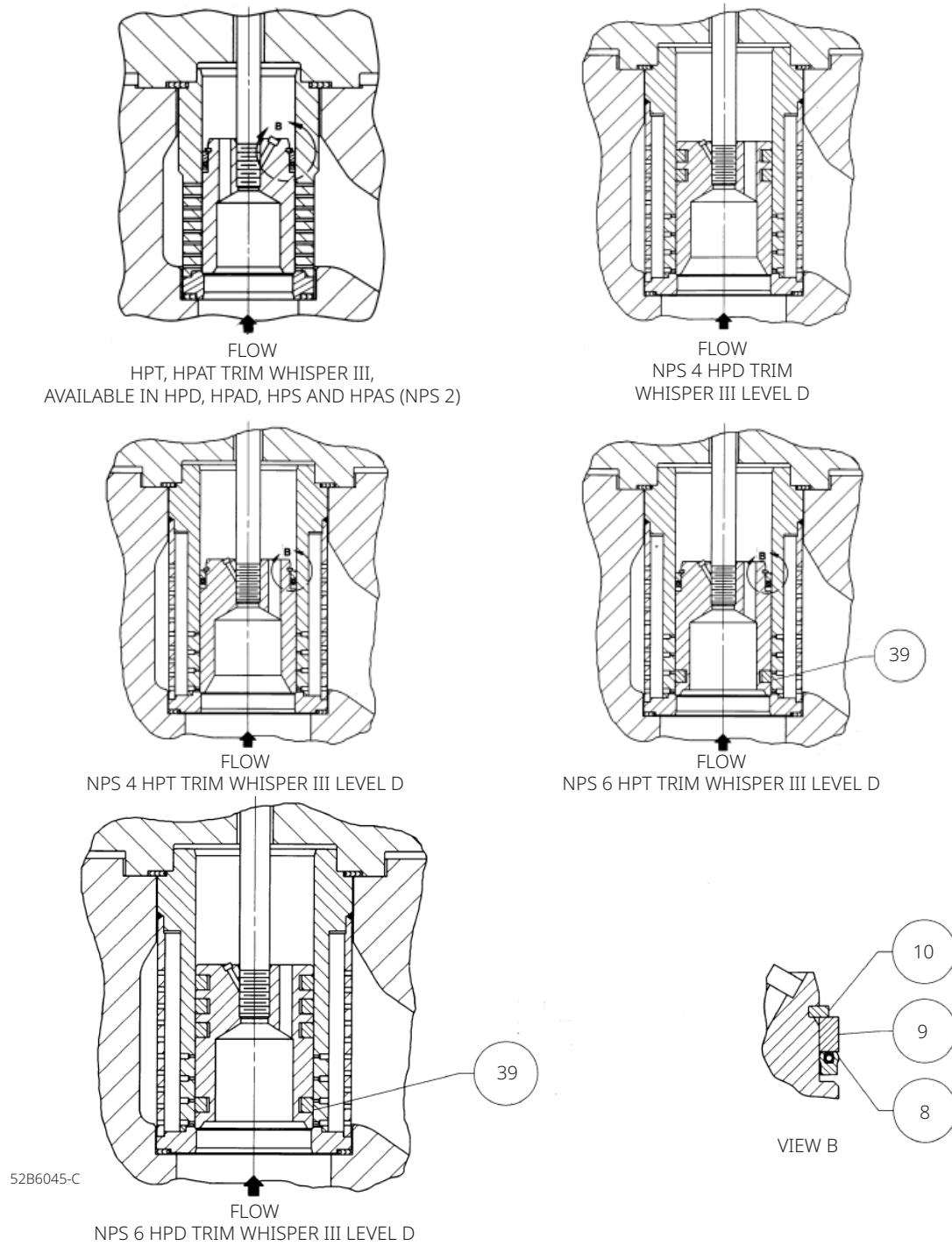

**Figure 26. NPS 8 to 12 HPD and HPT Valve with Skirted Bonnet**

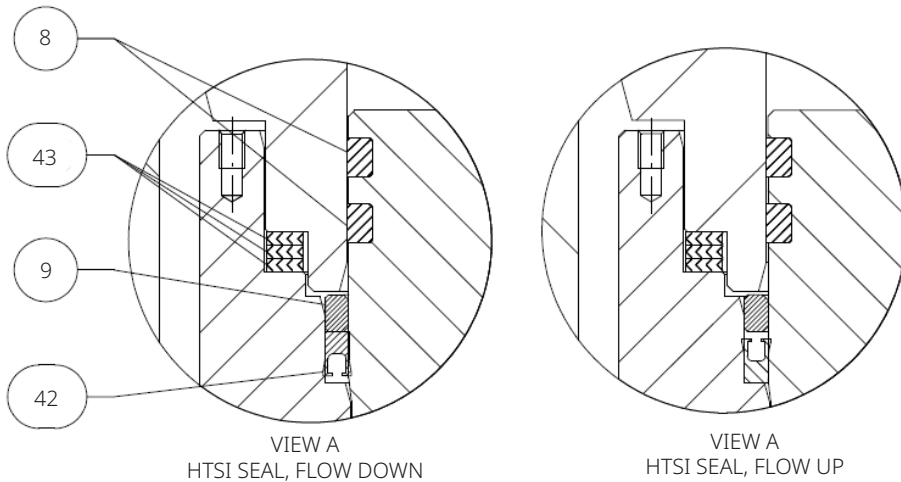
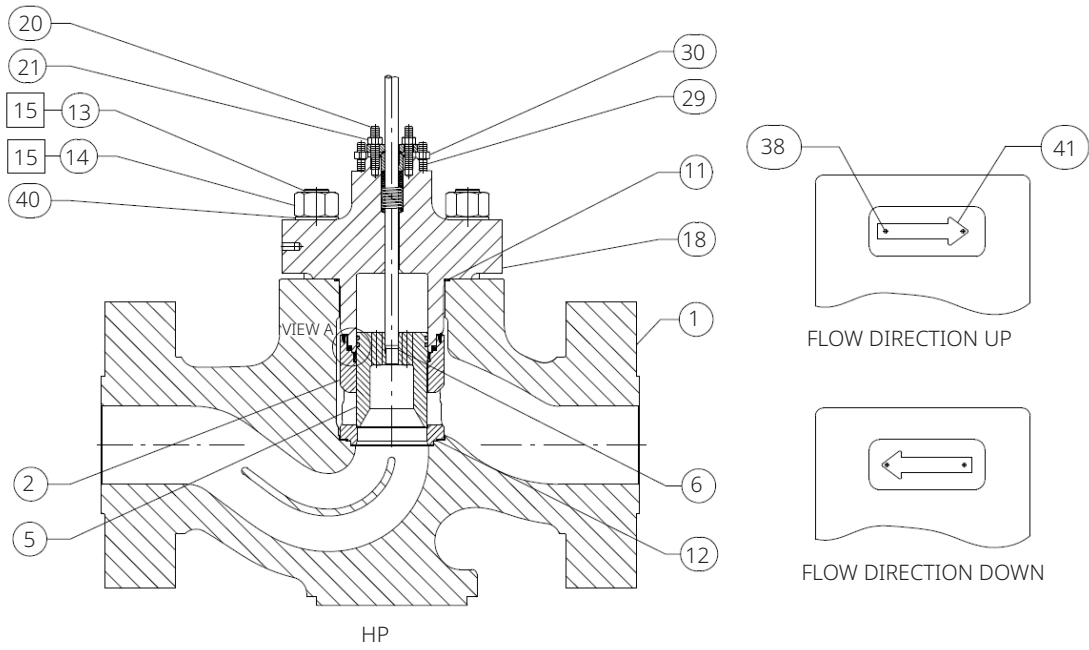

□ APPLY LUB  
PARTS NOT SHOWN 16, 17, 44

GG54316

**Figure 27. 8 to 12 HPD and HPT Valve with Skirted Bonnet - Alternate Configurations**

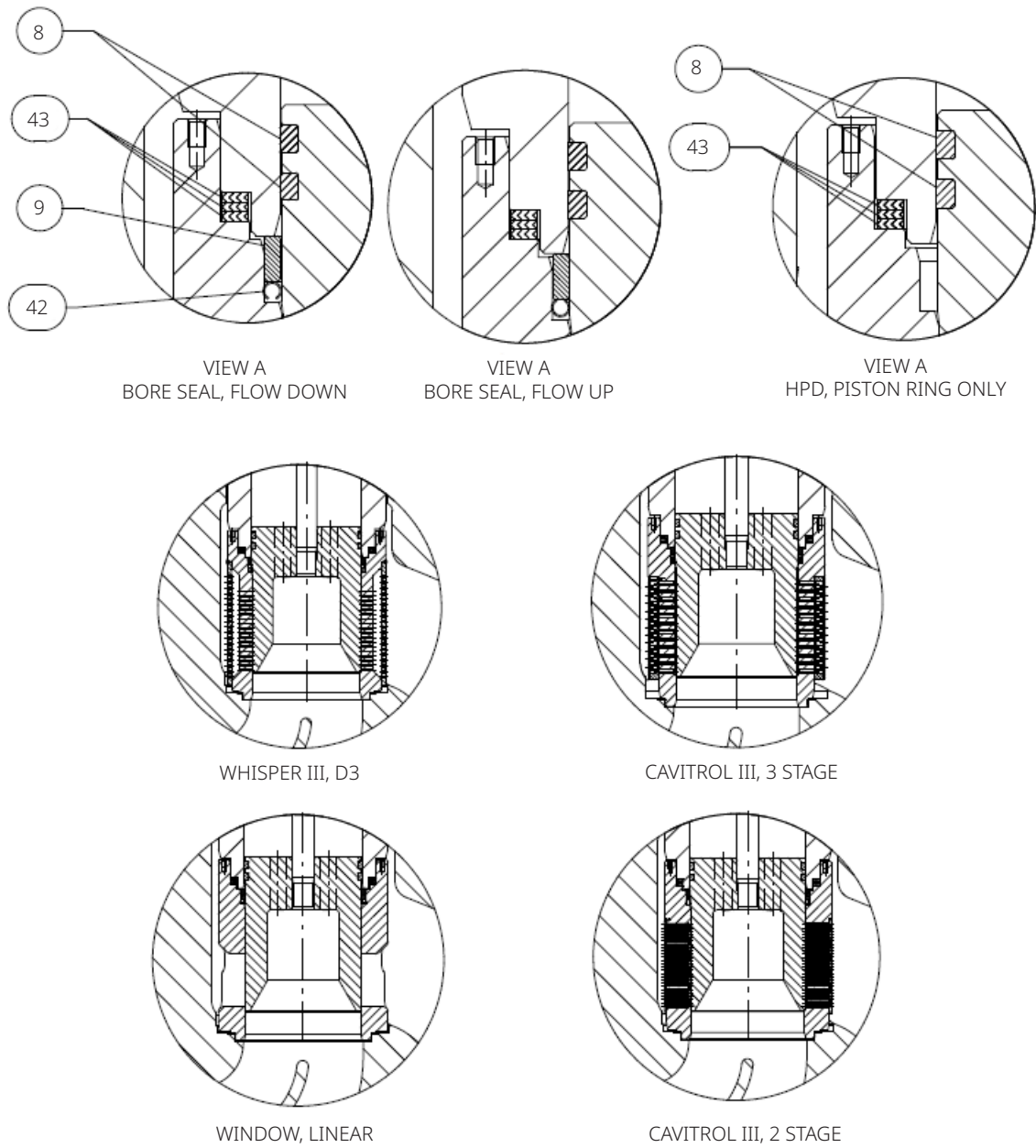

GG54316

**Figure 28. NPS 8 to 12 HPD and HPT Valve with Cage Retainer**

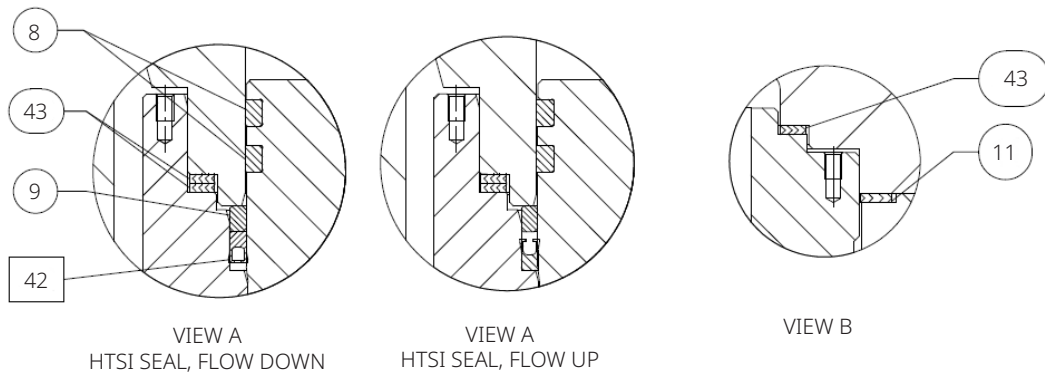
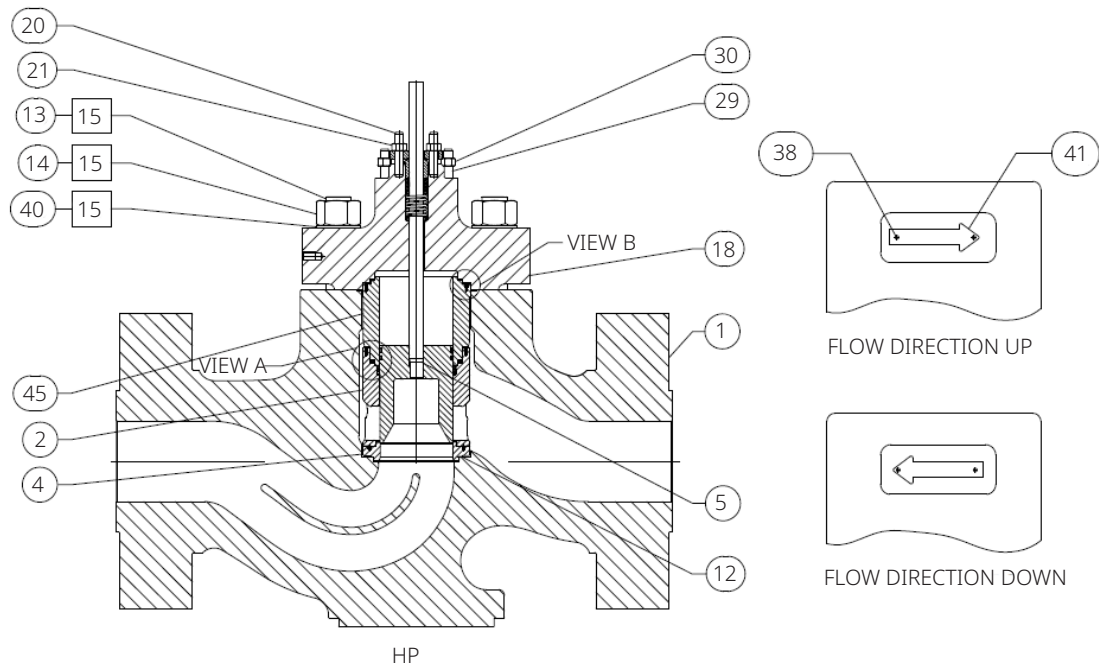

□ APPLY LUB  
PARTS NOT SHOWN 16, 17, 44

GG60128\_C

**Figure 29. NPS 8 to 12 HPD and HPT Valve with Cage Retainer - Alternate Configurations**

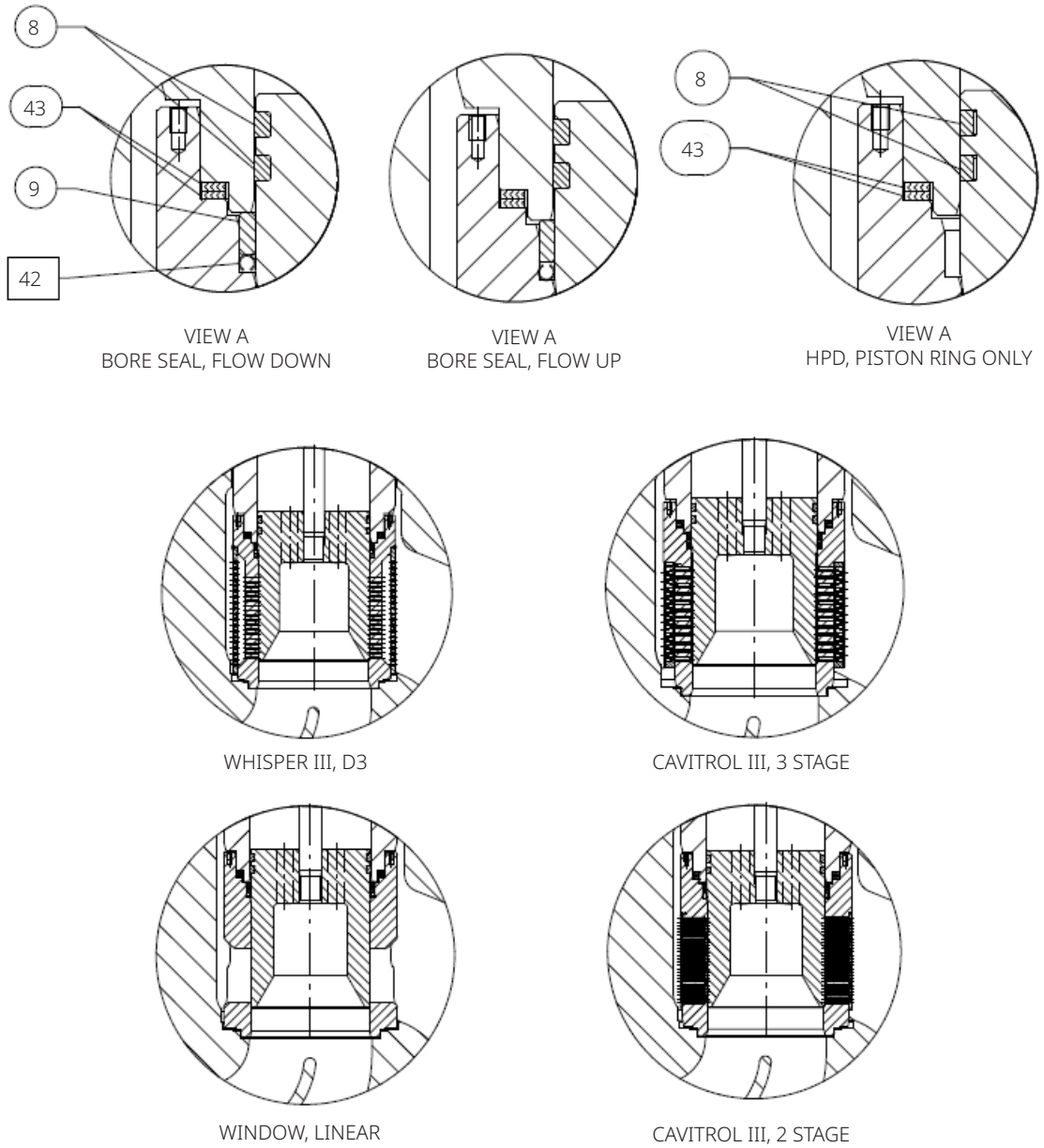

GG60128\_C

Figure 30. NPS 14 HPD and HPT Valve

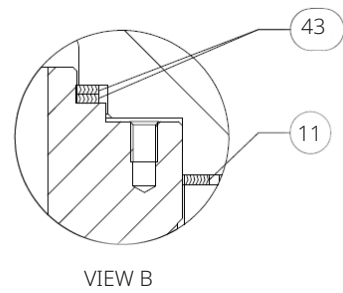
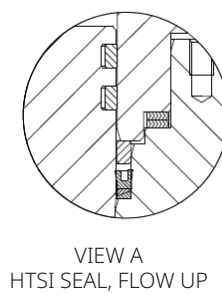
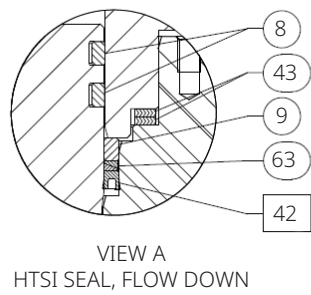
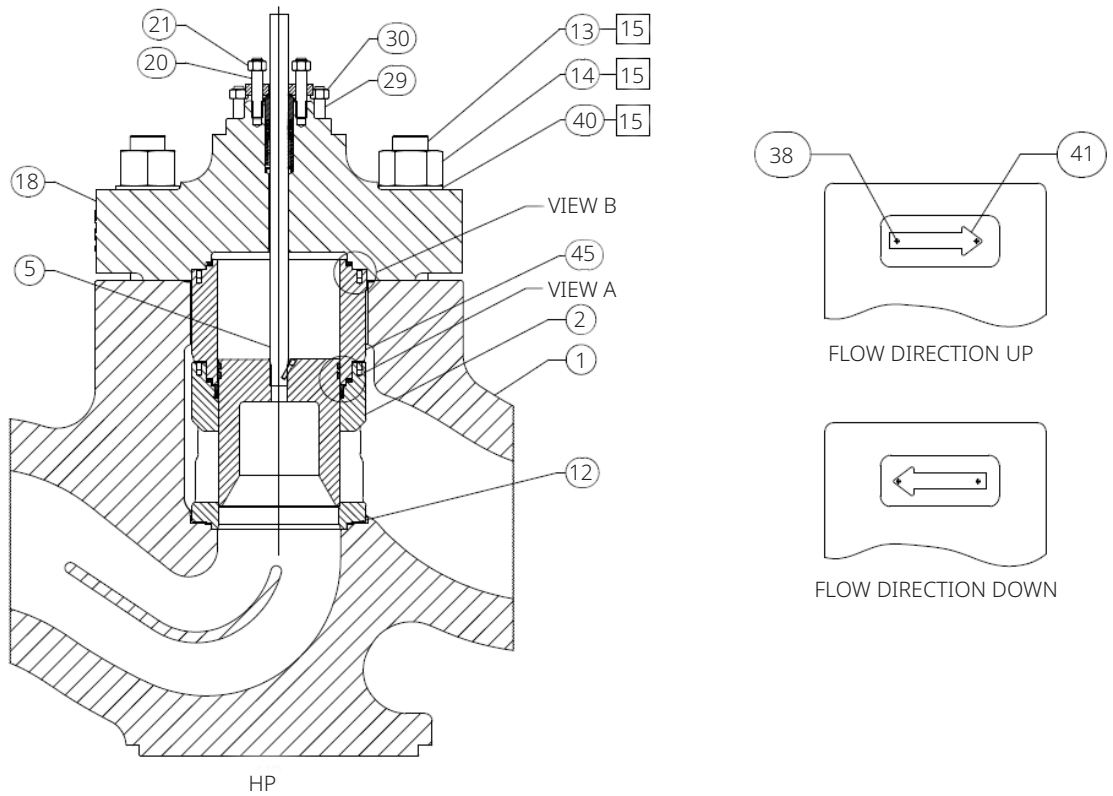

□ APPLY LUB  
PARTS NOT SHOWN 16, 17, 44

GH08059\_D

Figure 31. NPS 14 HPD and HPT Valve - Alternate Configurations

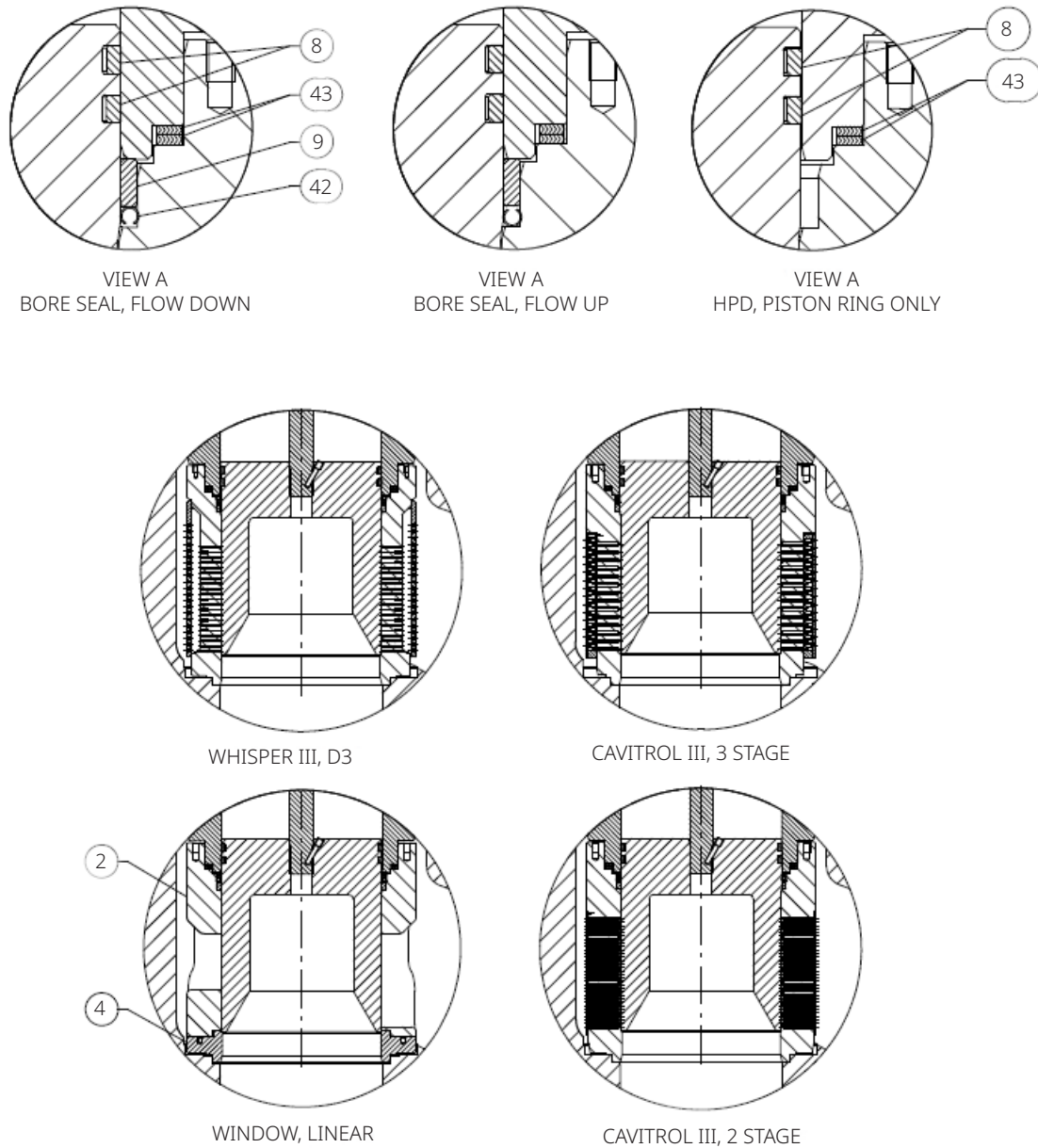

GH08059\_D

Figure 32. NPS 16 through 24 HPD and HPT Valve

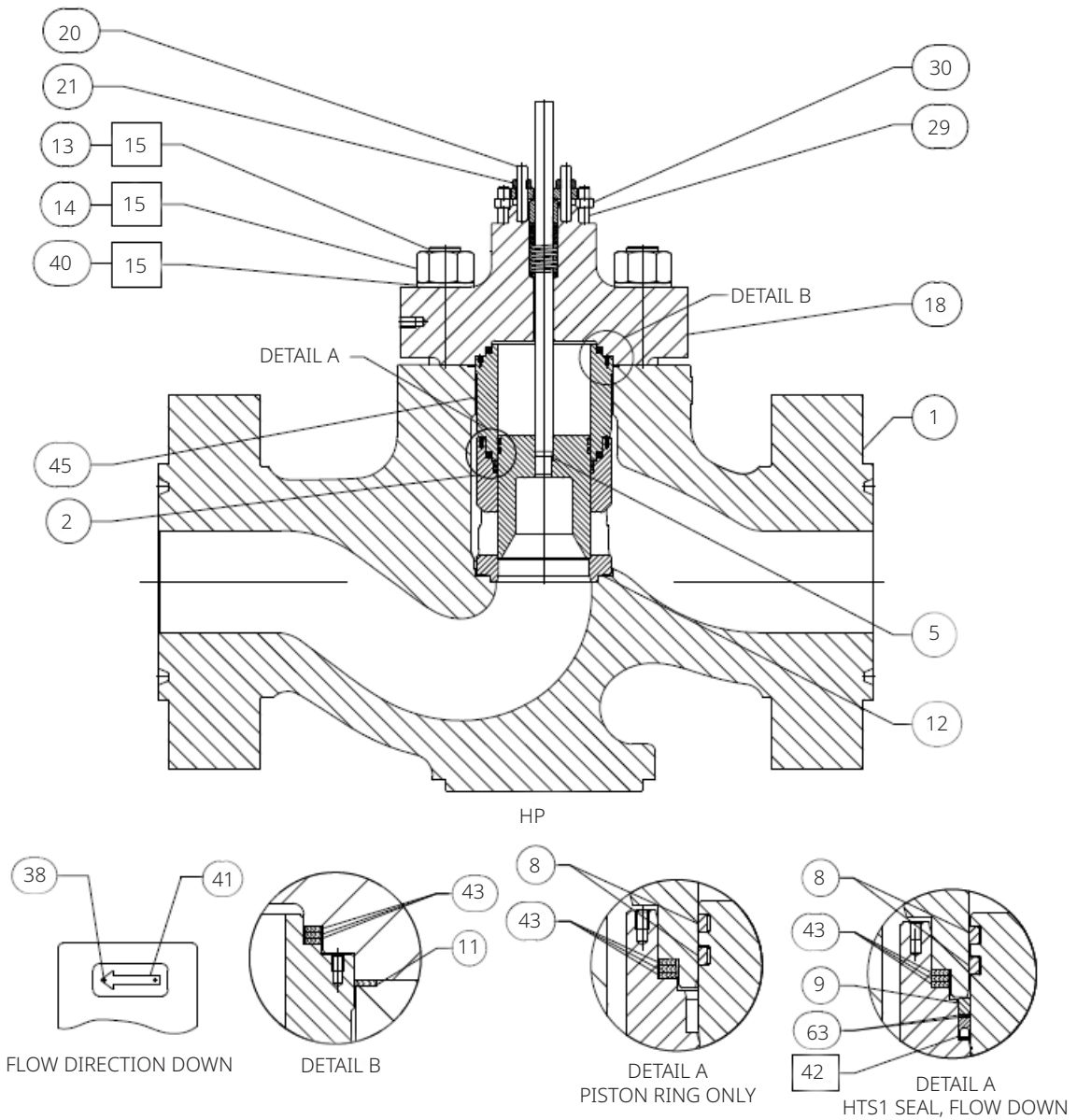

□ APPLY LUB  
PARTS NOT SHOWN 16, 17, 44

GG88282\_A

Figure 33. NPS 16 through 24 HPD and HPT Valve, Alternate Configurations

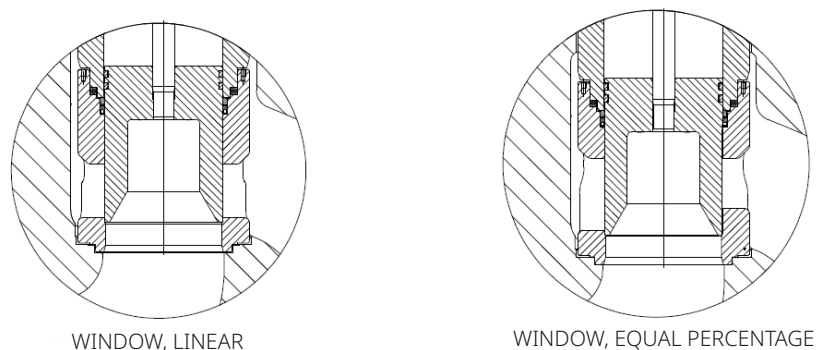

GG88282\_A

Figure 34. NPS 3 through 6 HPD (Short), HPT (Short) and HPS (Short) Valve

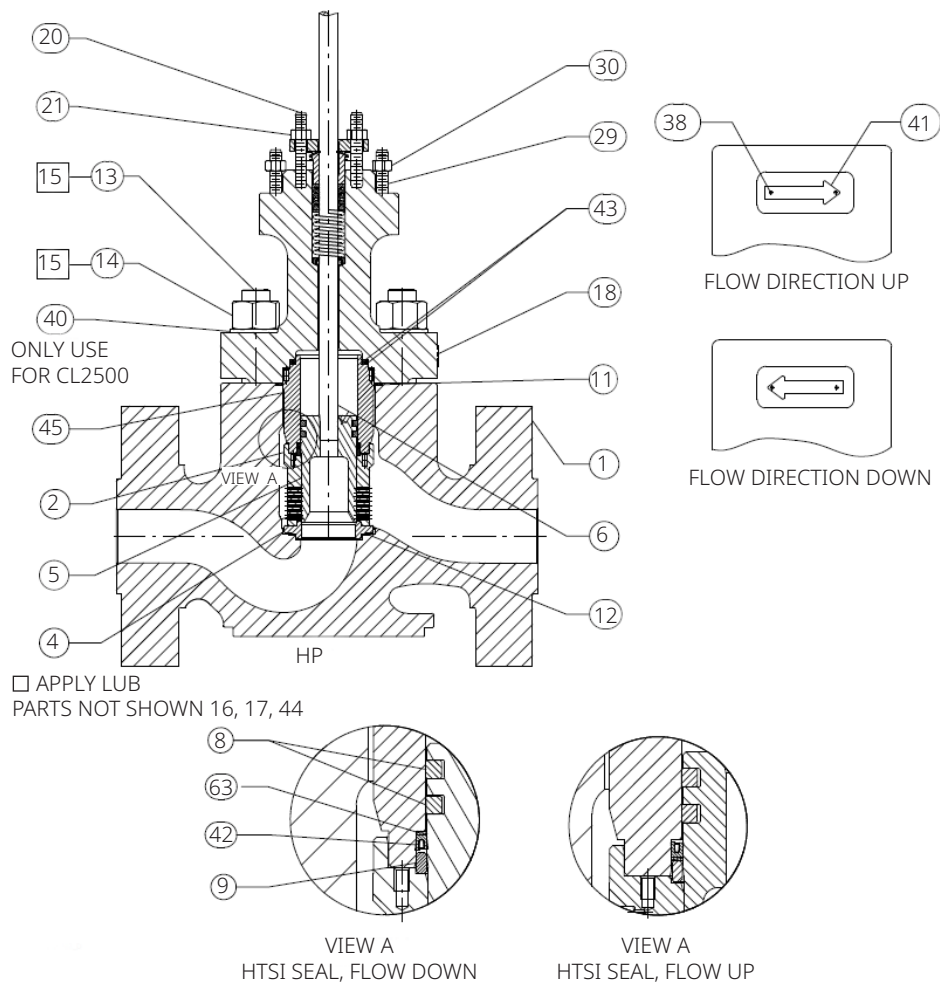

GG66792\_D

**Figure 35. NPS 3 through 6 HPD (Short), HPT (Short) and HPS (Short) Valve - Alternate Configurations**

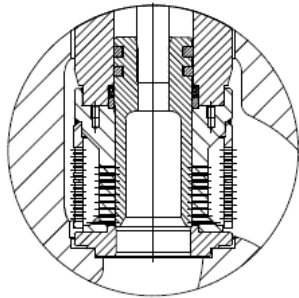

WHISPER III, D3

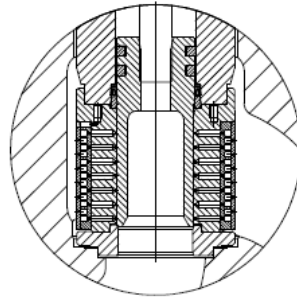

CAVITROL III, 3 STAGE

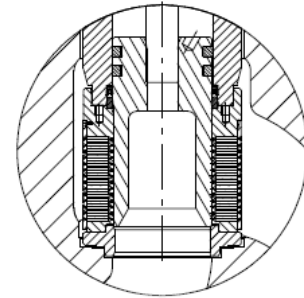

CAVITROL III, 2 STAGE

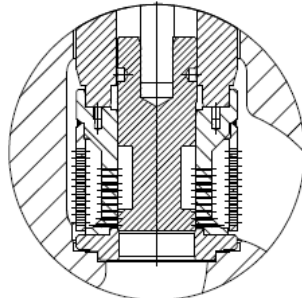

WHISPER III, D3  
HPS UNBALANCED PLUG OPTION

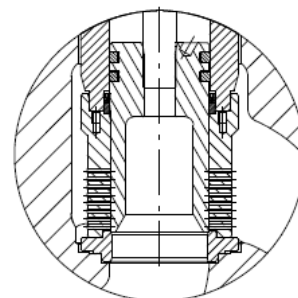

DRILLED HOLE, LINEAR

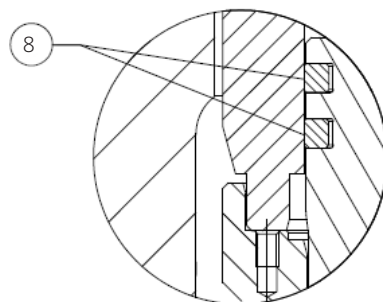

VIEW A  
HPD, PISTON RING ONLY

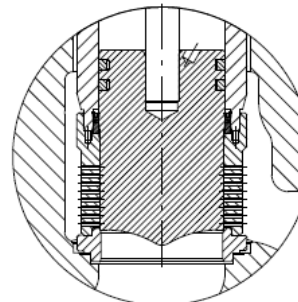

WHISPER III WITH CONTOUR PLUG  
ONLY USE FOR CL900/CL1500

GG66792\_D

Figure 36. NPS 6 and 8 HPAD and HPAT Valve

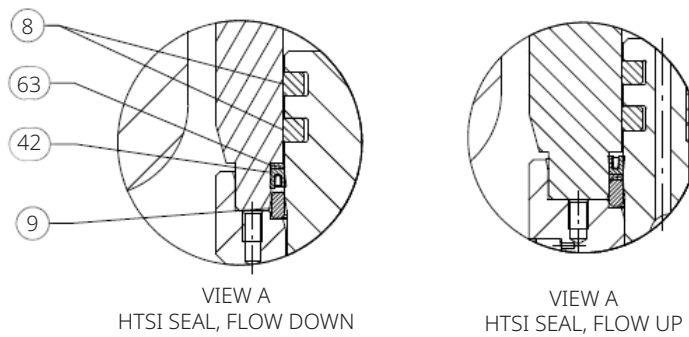
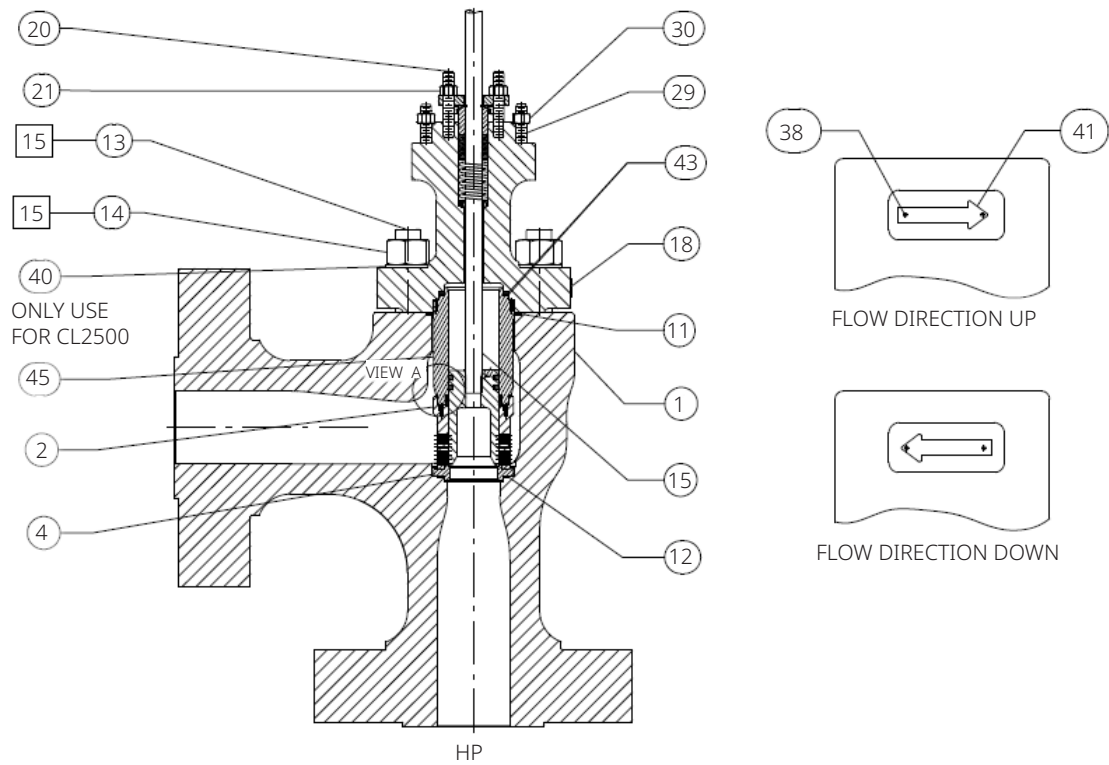

□ APPLY LUB  
PARTS NOT SHOWN 16, 17, 44

GG59686

Figure 37. NPS 6 and 8 HPAD and HPAT Valve - Alternate Configurations

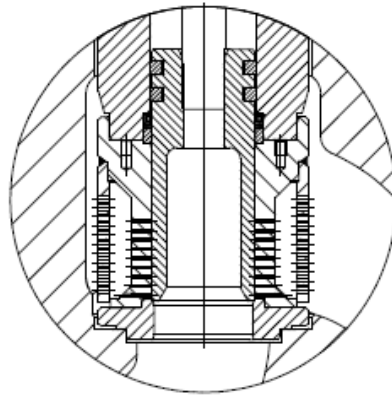

WHISPER III, D3

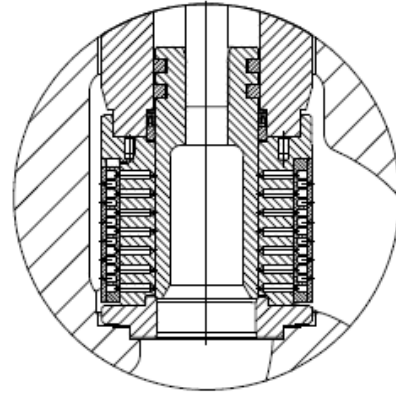

CAVITROL III, 3 STAGE

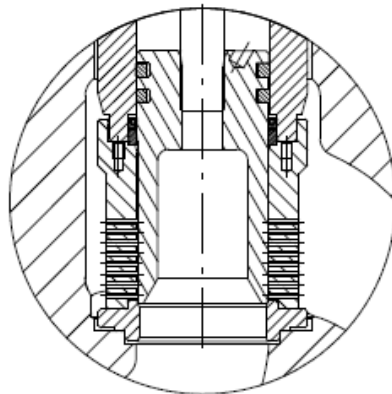

DRILLED HOLE, LINEAR

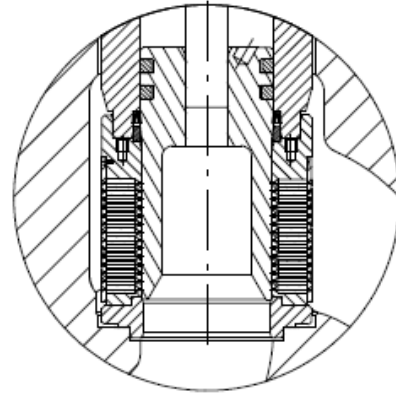

CAVITROL III, 2 STAGE

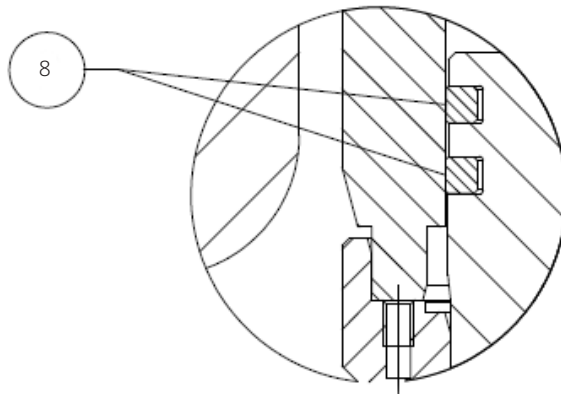

HPD, PISTON RING ONLY

GG59686

Figure 38. NPS 12 HPAD and HPAT Valve

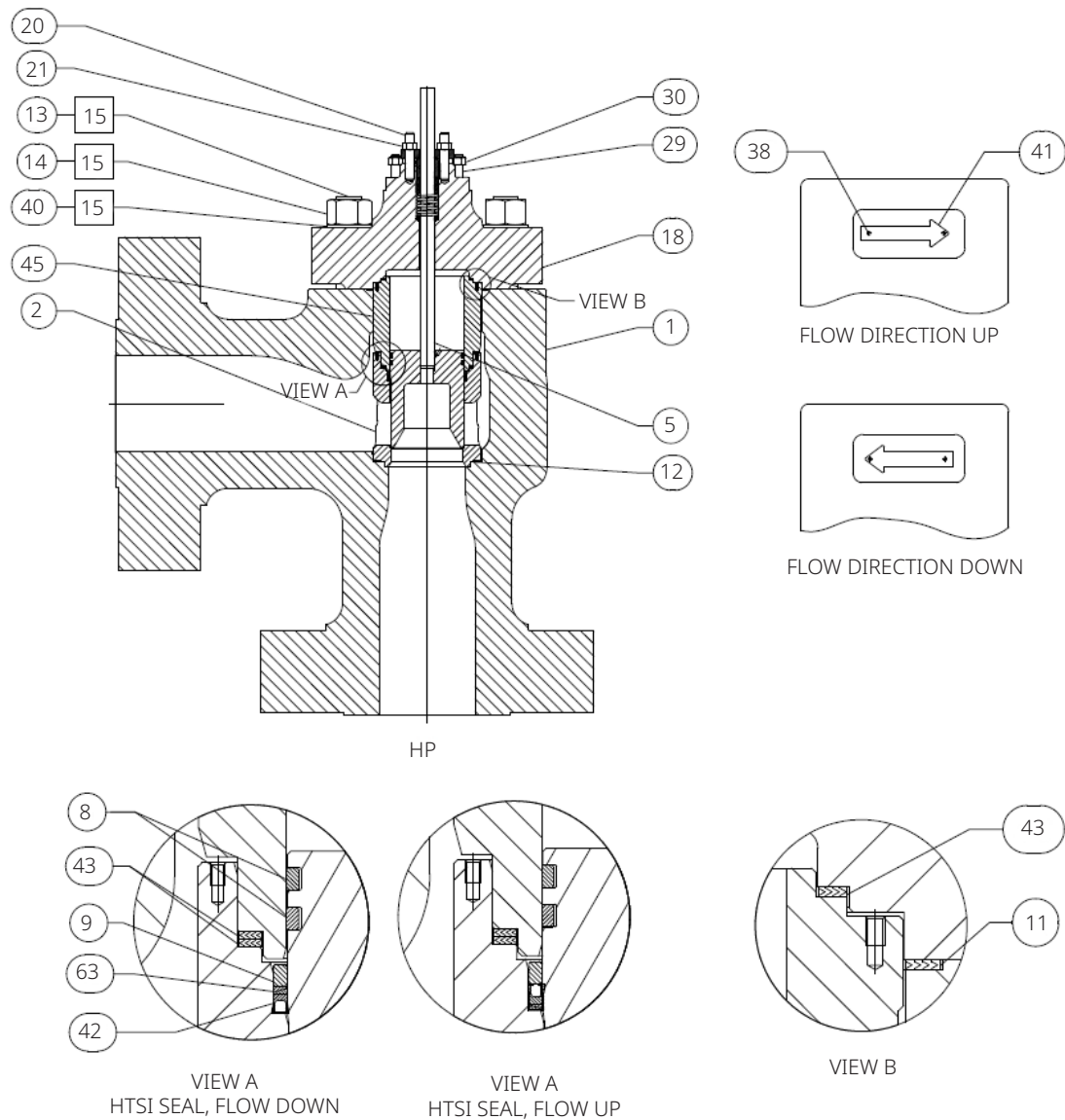

□ APPLY LUB  
PARTS NOT SHOWN 16, 17, 44

GG59688\_C

Figure 39. NPS 12 HPAD and HPAT Valve - Alternate Configurations

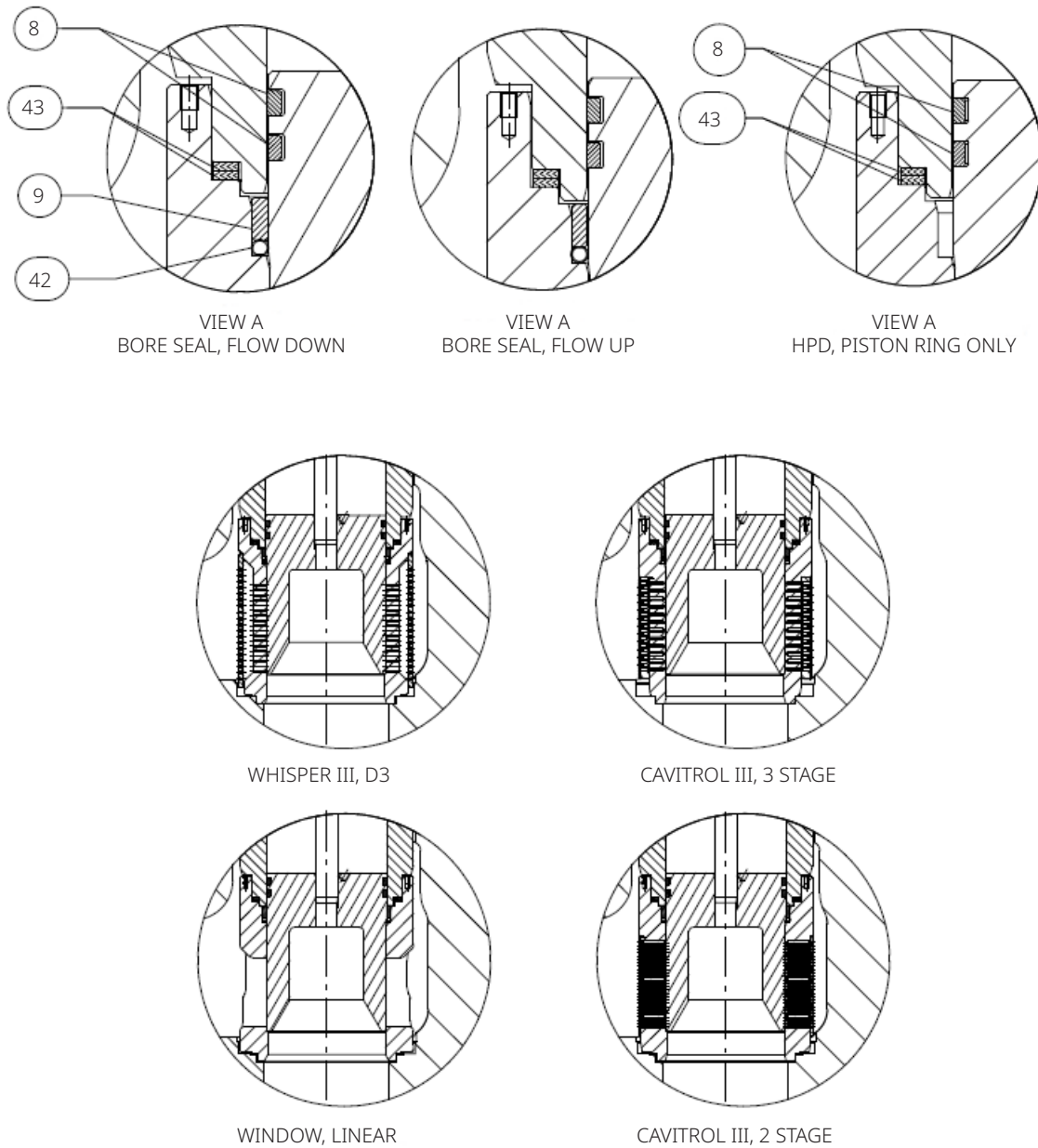

GG59688\_C

Figure 40. NPS 12 HPAD and HPAT Valve - Separated Seat - Alternate Configurations

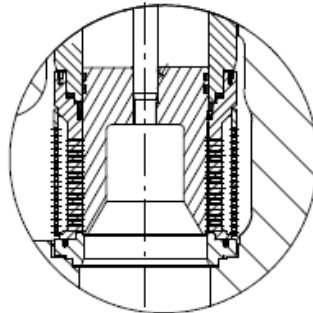
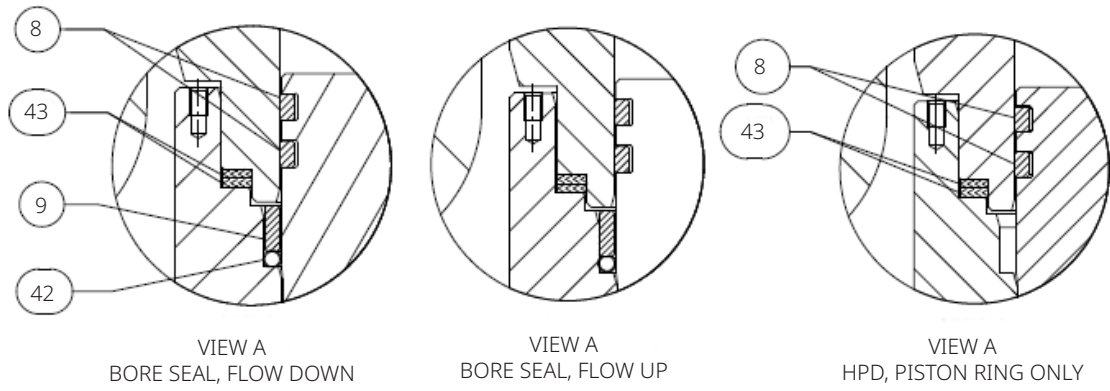

WHISPER III, D3

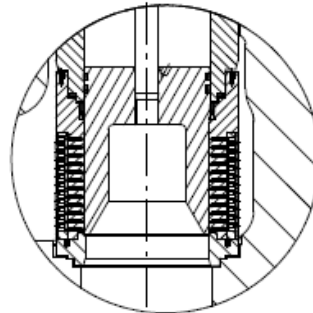

CAVITROL III, 3 STAGE

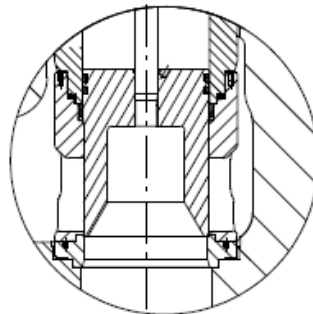

WINDOW, LINEAR

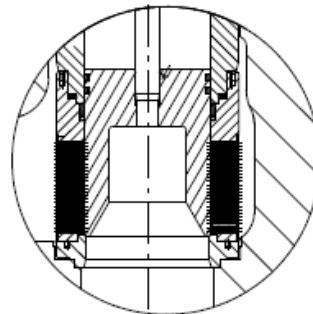

CAVITROL III, 2 STAGE

GG59687

## Section 6: Parts List

**NOTE**

Contact your [Emerson sales office](#) for Part Ordering information.

Key	Description	Key	Description
1	Valve Body If you need a valve body as a replacement part, order by valve size, serial number and desired material.	24	Spring or Lantern Ring
2*	Cage/Baffle Assy	25	Washer, Special
3	Bonnet Spacer	26*	Packing Box Ring
4*	Seat Ring	27*	Upper Wiper
5*	Valve Plug	28	Follower
6*	Valve Stem	29	Stud Bolt
7*	Pin	30	Hex Nut
8*	Seal Ring/Piston Ring	31	Pipe Plug (optional)
9*	Back Up Ring	31	Lubricator (optional)
10*	Retaining Ring (for NPS 6 and smaller HPT/HPAT only)	31	Lubricator/Isolating Valve (optional)
11*	Bonnet Gasket	32	Yoke Locknut (optional)
12*	Seat Ring Gasket	36	Baffle
13	Stud, Cont Thd	37	Retaining Ring
14	Hex Nut	38	Drive Screw
15	Anti-Seize Lubricant (8 lb / 3.6 Kg can)	39*	Piston Ring
16	Nameplate	40	Washer
17	Wire	41	Flow Arrow
18	Bonnet If you need a bonnet as a replacement part, order by valve size and stem diameter, serial number and desired material.	42*	Soft Seal or Bore seal
19	Packing Flange	43*	Cage Gasket
20	Stud Bolt	44	Nameplate
21	Hex Nut	45	Cage Retainer
22*	Packing Set	63*	Anti-Extrusion Ring
23*	Packing Ring	---	---
*Recommended spare parts			



### C-seal Trim (Figure 13)

Key	Description
2*	Cage
4*	Seat Ring
5*	Valve Plug/Retainer
6*	Valve Plug Stem
8*	Piston Ring (2 req'd)
64*	C-seal
*Recommended spare parts	

### TSO Trim (Figures 8, 9 and 10)

Key	Description
2*	Cage
4*	Seat Ring
5*	Plug/Stem Assembly
8*	Seal Ring
63*	Anti-Extrusion Ring
9*	Back Up Ring
10*	Retaining Ring
*Recommended spare parts	



 [LinkedIn.com/groups/3941826](https://www.linkedin.com/groups/3941826)  
 [Fisher.com](https://www.fisher.com)

 [Facebook.com/FisherValves](https://www.facebook.com/FisherValves)  
 [Twitter.com/FisherValves](https://twitter.com/FisherValves)

D101634X012 © 1991, 2024. Fisher Controls International LLC. All rights reserved.

**Neither Emerson, nor any of its affiliated entities assume responsibility for the selection, use or maintenance of any product. Responsibility for proper selection, use, and maintenance of any product remains solely with the purchaser and end user.**

Fisher, Cavitrol, ENVIRO-SEAL, FIELDVUE, Whisper Trim, and WhisperFlo are marks owned by one of the companies in the Emerson business unit of Emerson Electric Co. Emerson, and the Emerson logo are trademarks and service marks of Emerson Electric Co. All other marks are the property of their respective owners.

The contents of this publication are presented for informational purposes only, and while every effort has been made to ensure their accuracy, they are not to be construed as warranties or guarantees, express or implied, regarding the products or services described herein or their use or applicability. All sales are governed by our terms and conditions, which are available upon request. We reserve the right to modify or improve the designs or specifications of such products at any time without notice.

Emerson  
Marshalltown, Iowa 50158 USA  
Sorocaba, 18087 Brazil  
Cernay 68700 France  
Dubai, United Arab Emirates  
Singapore 128461 Singapore

[www.fisher.com](https://www.fisher.com)