

July 2025

67C Series Instrument Supply Regulators

- Designed for Digital Instrumentation
- Optional Smart Bleed™ Construction
- Optional Stainless Steel Construction
- Optional Arctic Construction
- Compact and Light Weight
- No Air Loss
- Easy Maintenance
- Optional Integral Filter
- Optional Internal Relief Valve
- Rugged Construction

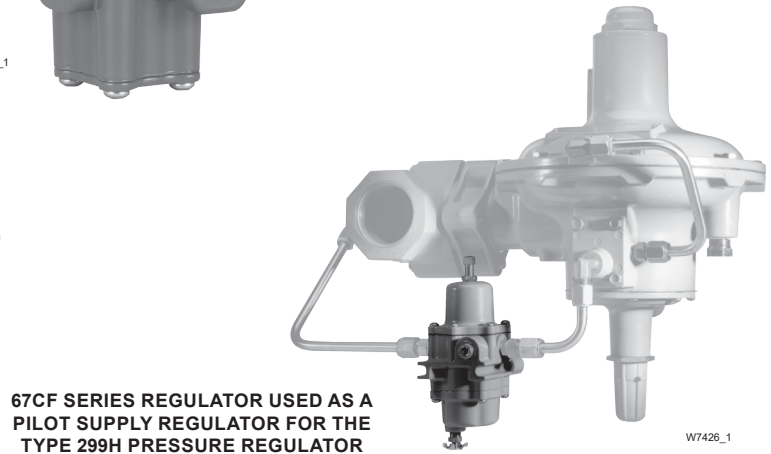
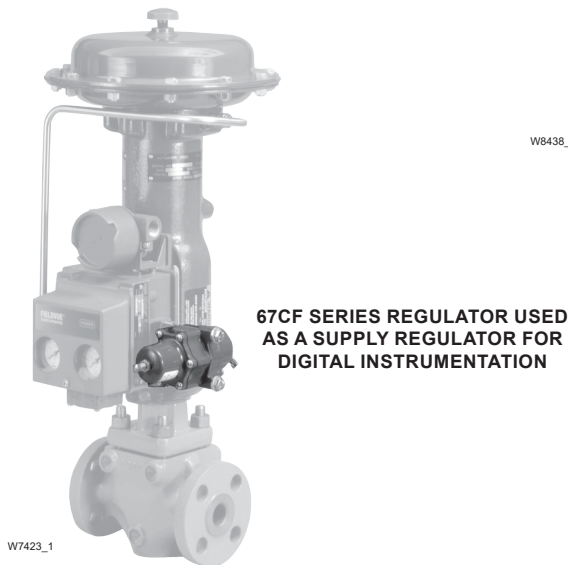
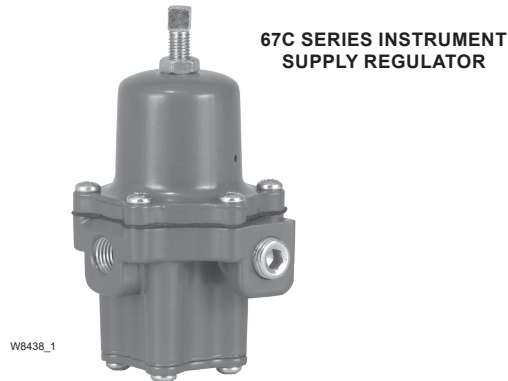

Figure 1. 67C Series Instrument Supply Regulators

67C Series

Specifications

The Specifications section gives some general specifications for the 67C Series Regulator. A label on the spring case gives the control spring range for a given regulator as it comes from the factory.

Available Constructions

See Table 2

Body Size, Inlet and Outlet Connection Style

1/4 NPT

Construction Materials

See Table 3

Maximum Inlet Pressure (Body Rating)⁽¹⁾

All Except Types 67CS and 67CSR: 250 psig / 17.2 bar
Types 67CS and 67CSR: 400 psig / 27.6 bar

Outlet Pressure Ranges

See Table 1

Maximum Emergency Outlet Pressure⁽¹⁾

50 psi / 3.4 bar over outlet pressure setting

Flow Capacities

See Table 4

Wide-Open Flow Coefficients

Main Valve: C_g : 11.7; C_v : 0.36; C_f : 32.2
Internal Relief Valve: C_g : 1.45; C_v : 0.045; C_f : 32.8

IEC Sizing Coefficients

Main Valve: X_T : 0.66; F_L : 0.89; F_D : 0.50

Accuracy

Inlet Sensitivity for Nitrile (NBR) and Silicone (VMQ) Elastomers: Less than 0.2 psig / 14 mbar change in outlet pressure for every 25 psig / 1.7 bar change in inlet pressure

Inlet Sensitivity for Fluorocarbon (FKM) Elastomers: Less than 0.4 psig / 28 mbar change in outlet pressure for every 25 psig / 1.7 bar change in inlet pressure

Repeatability for Nitrile (NBR) and Silicone (VMQ) Elastomers: 0.1 psig / 7 mbar⁽²⁾

Repeatability for Fluorocarbon (FKM) Elastomers: 0.3 psig / 21 mbar⁽²⁾

Air Consumption: Testing repeatedly shows no discernible leakage

Types 67CR, 67CSR, 67CFR and 67CFSR Internal Relief Performance

Low capacity for minor seat leakage only, other overpressure protection must be provided if inlet pressure can exceed the maximum pressure rating of downstream equipment or exceeds maximum outlet pressure rating of the regulator.

Approximate Weights

Types 67C, 67CR, 67CF and 67CFR: 1 lb / 0.5 kg

Types 67CS and 67CSR: 2.5 lbs / 1.1 kg

Types 67CFS and 67CFSR: 4 lbs / 1.8 kg

Smart Bleed™ Check Valve Setpoint

6 psi / 0.41 bar differential

Pressure Registration

Internal

Drain Valve and Spring Case Vent Location

Aligned with inlet standard, other positions optional

Temperature Capabilities⁽¹⁾

With Nitrile (NBR)

Standard bolting: -20 to 180°F / -29 to 82°C
Stainless steel bolting: -40 to 180°F / -40 to 82°C

With Fluorocarbon (FKM)⁽⁶⁾

Polyethylene Filter⁽⁶⁾ (standard): 0 to 180°F / -18 to 82°C
Stainless steel or Glass Filter (optional): 0 to 300°F / -18 to 149°C

With Silicone (VMQ)⁽³⁾

Diaphragm and Low Temperature bolting: -60 to 180°F / -51 to 82°C
With Gauges: -40 to 180°F / -40 to 82°C

Arctic/Extreme Low Temperature Construction⁽³⁾⁽⁸⁾

*Low Temperature Silicone (VMQ)/
Fluorosilicone (FVMQ)/Nitrile (NBR) and
Low Temperature bolting:* -76 to 140°F / -60 to 60°C

Types 67CF, 67CFR, 67CFS and 67CFSR Filter Capabilities

Free Area: 12 times pipe area

Micron Rating:

Polyethylene Filter⁽⁵⁾ (standard): 5 microns
Glass Fiber Filter (optional): 5 microns
Stainless steel Filter (optional): 40 microns

Options

All Types

- Handwheel adjusting screw
- Inlet screen
- NACE MR0175⁽⁴⁾ or NACE MR0103 construction
- Panel mount (includes spring case with 1/4 NPT vent, handwheel and panel mounting nut)
- Closing cap (available on spring case with 1/4 NPT vent)
- Fluorocarbon (FKM) elastomers for high temperatures and/or corrosive chemicals
- Silicone (VMQ) elastomers for cold temperatures
- Fixed bleed restriction
- Triple scale outlet pressure gauge (Brass or Stainless steel)
- Stainless steel stem on the valve plug
- Tire valve or pipe plug in second outlet

Types 67CFR and 67CFSR only

- Smart Bleed internal check valve⁽⁷⁾
- Large dripwell with manual or automatic drain

Types 67CF and 67CFR only

- Stainless steel drain valve

1. The pressure/temperature limits in this Bulletin and any applicable standard or code limitation should not be exceeded.
2. Repeatability is the measure of the regulator's ability to return to setpoint consistently when traveling from steady state to transient to steady state.
3. Silicone (VMQ) is not compatible with hydrocarbon gas. When utilizing a silicon-based diaphragm, typically reserved for low-temperature or arctic applications, minor vent leakage may occur.
4. Product complies with the material requirements of NACE MR0175. Environmental limits may apply.
5. Do not use in high aromatic hydrocarbon service.
6. Consult factory for applications where the Smart Bleed unit will be at process temperatures above 180°F / 82°C for an extended period.
7. The Smart Bleed internal check valve is bubble tight at temperatures down to -40°F / -40°C. Leakage from P₁ to P₂ is possible at temperatures below -40°F / -40°C.
8. The arctic / extreme low temperature construction passed Emerson laboratory testing for lockup and external leakage down to -76°F / -60°C. Some internal relief valve venting may occur at temperatures below -58°F / -50°C.

Table 1. Outlet Pressure Ranges and Control Spring Data

TYPE	OUTLET PRESSURE RANGE		CONTROL SPRING DATA						
			Color	Material	Part Number	Wire Diameter		Free Length	
	psig	bar				In.	mm	In.	mm
67C, 67CR, 67CF and 67CFR	0 to 20	0 to 1.4	Green stripe	Music Wire	GE07809T012	0.135	3.43	1.43	36.2
	0 to 35	0 to 2.4	Silver		T14059T0012	0.156	3.96	1.43	36.2
	0 to 60	0 to 4.1	Blue stripe		T14058T0012	0.170	4.32	1.43	36.2
	0 to 125	0 to 8.6	Red stripe		T14060T0012	0.207	5.26	1.43	36.2
	0 to 35	0 to 2.4	Silver stripe	Inconel®	T14113T0012	0.156	3.96	1.43	36.2
	0 to 60	0 to 4.1	Blue		T14114T0012	0.172	4.37	1.43	36.2
0 to 125	0 to 8.6	Red	T14115T0012		0.207	5.26	1.43	36.2	
67CS, 67CSR, 67CFS and 67CFSR	0 to 20	0 to 1.3	Green	Inconel®	10C1729X012	0.135	3.43	1.50	38.1
	0 to 35	0 to 2.4	Silver stripe		T14113T0012	0.156	3.96	1.43	36.2
	0 to 60	0 to 4.1	Blue		T14114T0012	0.172	4.37	1.43	36.2
	0 to 125	0 to 8.6	Red		T14115T0012	0.207	5.26	1.43	36.2
	0 to 150	0 to 10.3	Black		10C1730X012	0.250	6.35	1.77	44.9

Introduction

The 67C Series Regulators are typically used to provide constantly controlled, reduced pressures to pneumatic and electro-pneumatic controllers and other instruments. These direct-operated regulators are suitable for most air or gas applications. Other applications include providing reduced pressures to air chucks, air jets and spray guns.

Features

- **Compact**—The 67C Series Regulators are engineered for outstanding performance in a compact, lightweight package.
- **Panel Mounting**—Panel mount construction includes spring case with 1/4 NPT vent, handwheel adjusting screw and mounting nut.
- **Instrument Supply Regulator**—The Types 67CF, 67CFR, 67CFS and 67CFSR provide a clean air supply to a variety of pneumatic and electro-pneumatic instrumentation.
- **Digital Instrument Supply Regulator**—Designed to meet the accuracy, repeatability and hysteresis demands of digital instrumentation.
- **Pilot Supply Regulator**—Improves the accuracy of two-path control regulators by reducing inlet sensitivity caused by fluctuating inlet pressures.
- **Sour Gas Service Capability**—NACE MR0175 and MR0103 compliant construction available.
- **Optional Stainless Steel Construction**—The Types 67CS, 67CSR, 67CFS and 67CFSR provide high resistance to corrosion, which is especially beneficial for offshore applications.
- **Full Usable Capacity**—Fisher™ Regulators are laboratory tested. 100% of the published capacities can be used with confidence.
- **Internal Relief**—The Types 67CR, 67CSR, 67CFR and 67CFSR have an internal relief valve with a soft seat for reliable shutoff with no discernible leakage. These regulators are recommended for conserving plant air.
- **Smart Bleed™**—Opens to exhaust downstream pressure when inlet pressure drops below outlet pressure. Recommended for dead-end service, fail-safe actuators and no bleed applications.
- **Integral Filter**—The Types 67CF, 67CFR, 67CFS and 67CFSR have an integral filter ensuring clean downstream air supply.
- **Ease of Maintenance**—No special tools required to perform maintenance and all maintenance can be performed with the regulator in the line. Filter elements are easily replaced. The one-piece valve plug cartridge allows easy inspection and replacement.
- **Rugged Construction**—The 67C Series Regulators are engineered for longer service life with minimal maintenance requirements.
- **Second Outlet**—Body side outlet for pressure gauge or other uses.
- **Powder Paint Coating**—Types 67C, 67CR, 67CF and 67CFR are powder paint coated, offering impact, abrasion and corrosion resistance. Stainless steel regulators (Types 67CS, 67CSR, 67CFS and 67CFSR) are not painted.
- **Corrosion Resistant Fasteners**—Bolting and adjusting screw are double zinc-chromated for enhanced corrosion resistance. Optional stainless steel bolting and adjusting screw are also available.
- **Arctic Temperatures**—Constructions for process temperatures as low as -76°F / -60°C available by request.
- **Hydrogen Ready**—Products have been evaluated for material compatibility, potential leakage and permeation and susceptibility to embitterment for Hydrogen applications. Based on an extensive evaluation and testing program, 67C Series configurations are available for use in Hydrogen applications.

Principle of Operation (Figure 2)

Downstream pressure is registered internally on the lower side of the diaphragm. When the downstream pressure is at or above the set pressure, the valve plug is held against the orifice and there is no flow through the regulator. When demand increases, downstream pressure drops slightly allowing the spring to extend, moving the stem down and the valve plug away from the orifice. This allows flow through the regulator.

Inconel® is a marked own by Special Metals Corporation.

67C Series

Table 2. Available Constructions

TYPE	CONSTRUCTION FEATURES		OPTIONAL FEATURES			BODY MATERIAL	
	With Internal Relief	With Filter	Smart Bleed Internal Check Valve Airset	Drain Valve	Fixed Bleed	Aluminum	Stainless steel
67C						X	
67CR	X				X	X	
67CS							X
67CSR	X				X		X
67CF		X		X		X	
67CFR	X	X	X	X	X	X	
67CFS		X		X			X
67CFSR	X	X	X	X	X		X

Table 3. Construction Materials

MATERIAL	TYPE			
	67C and 67CR	67CF and 67CFR ⁽²⁾	67CS and 67CSR	67CFS and 67CFSR ⁽²⁾
BODY AND SPRING CASE	Aluminum (ASTM B85/Alloy 380)		CF8M/CF3M Stainless steel	
BOTTOM PLATE	316 Stainless steel	----	316 Stainless steel	----
PUSHER POST AND VALVE CARTRIDGE	Polyester resin			
UPPER SPRING SEAT	Zinc-plated steel		316 Stainless steel	
LOWER SPRING SEAT, DIAPHRAGM PLATE	Chromate conversion coated Aluminum		316 Stainless steel	
CONTROL SPRING	Plated steel or Inconel [®] (NACE)		Inconel [®]	
VALVE PLUG	Brass stem with Nitrile (NBR) plug, Aluminum stem with Nitrile (NBR) or Fluorocarbon (FKM) plug or Stainless steel stem with Nitrile (NBR) plug		316 Stainless steel stem with Nitrile (NBR) or Fluorocarbon (FKM) plug	
VALVE SPRING	Stainless steel or Inconel [®] (NACE)		Inconel [®]	
DIAPHRAGM AND O-RINGS	Nitrile (NBR), Fluorocarbon (FKM) or Silicone (VMQ) ⁽¹⁾			
SOFT SEAT AND GASKETS	Nitrile (NBR) or Fluorocarbon (FKM)			
BOLTING, ADJUSTING SCREW, LOCKNUT	Zinc-plated steel or Stainless steel		Stainless steel	
HANDWHEEL	Zinc-plated steel screw with resin handwheel			
FILTER RETAINER	----	Plated steel	----	316 Stainless steel
FILTER ELEMENT	----	Polyethylene, Glass fiber or Stainless steel	----	Polyethylene, Glass fiber or 316 Stainless steel
DRAIN VALVE	----	Brass or Stainless steel	----	316 Stainless steel or 18-8 Stainless steel
DRIPWELL	----	Aluminum (ASTM B85/Alloy 380)	----	CF8M/CF3M Stainless steel

1. Silicone (VMQ) diaphragm is only available with internal relief (Types 67CR, 67CSR, 67CFR and 67CFSR).
2. Contact factory for arctic / extreme low temperature constructions.

Internal Relief (Types 67CR, 67CSR, 67CFR and 67CFSR)

If for some reason, outside of normal operating conditions, the downstream pressure exceeds the setpoint of the regulator, the force created by the downstream pressure will lift the diaphragm until the diaphragm is lifted off the relief seat. This allows flow through the token relief. The relief valve on the Type 67CR, 67CSR, 67CFR or 67CFSR is an elastomer plug that prevents leakage of air from the downstream to atmosphere during normal operation, thereby conserving plant air.

Smart Bleed™ Airset

Recommended for fail-safe actuators, no bleed applications and dead-end service.

In some cases, it is desired to exhaust downstream pressure if inlet pressure is lost or drops below the setpoint of the regulator. For example, if the regulator is installed on equipment that at times has no flow demand but is expected to backflow on loss of inlet pressure. The Types 67CFR and 67CFSR can be ordered with the Smart Bleed option which includes an integrated soft seat check valve. During operation, if inlet pressure is lost or decreases below the setpoint of the regulator, the downstream pressure will back flow upstream through the regulator and check valve. This option eliminates the need for a fixed bleed downstream of the regulator, thereby conserving plant air. In addition, the soft seat feature of the check valve eliminates leakage while the airset is in the lock-up position, preventing pressure build-up that could trip safety loop functions on valves.

Inconel[®] is a marked own by Special Metals Corporation.

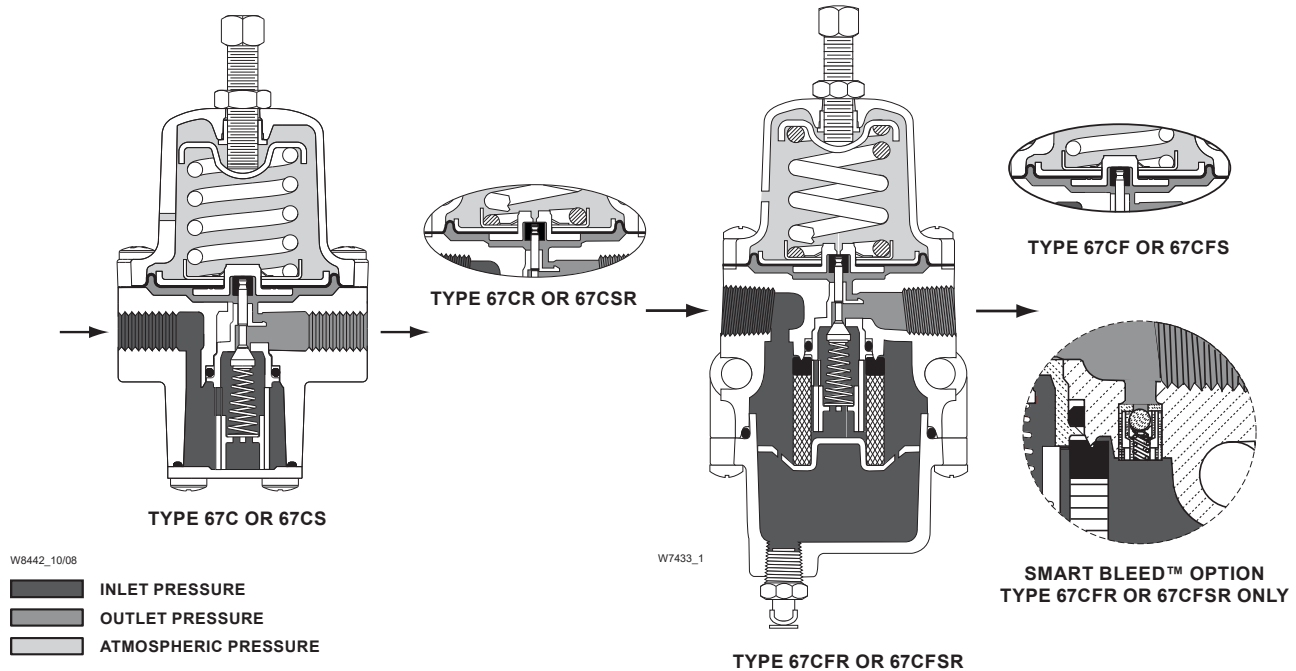

Figure 2. 67C Series Operational Schematics

Installation

The 67C Series Regulators may be installed in any position but vertical orientation is recommended for 67C Series models with draining features. Spring case vents must be protected against the entrance of rain, snow, debris or any other foreign material that might plug the vent openings. The inlet connection is marked “In” and the two outlet connections are marked “Out”. If a pressure gauge is not installed in one outlet connection, plug the unused connection. See Figures 5 to 9 for dimensions.

Emerson Process Management Regulator Technologies, Inc. (Emerson) provides an instruction manual with every regulator shipped. Refer to this for complete installation, operation and maintenance instructions. Included is a complete listing of individual parts and recommended spare parts.

Overpressure Protection

The 67C Series Regulators have maximum outlet pressure ratings that are lower than their maximum inlet pressure ratings. A pressure-relieving or pressure-limiting device is needed if inlet pressure can exceed the maximum outlet pressure rating.

Types 67CR, 67CSR, 67CFR and 67CFSR Regulators have a low capacity internal relief valve for minor seat leakage only. Other overpressure protection must be provided if the maximum inlet pressure can exceed the maximum pressure rating of the downstream equipment or exceeds maximum outlet pressure rating of the Type 67CR, 67CSR, 67CFR or 67CFSR Regulator.

Overpressuring any portion of a regulator or associated equipment may cause leakage, parts damage or personal injury due to bursting of pressure-containing parts or explosion of accumulated gas. Regulator operation within ratings does not preclude the possibility of damage from external sources or from debris in the pipeline. A regulator should be inspected for damage periodically and after any overpressure condition.

Refer to the Capacity Information section and the Wide-Open Flow Coefficients for Relief Valve Sizing in the Specifications section on page 2 to determine the required relief valve capacity.

Capacity Information

Table 4 shows the air regulating capacities of the 67C Series Regulators at selected inlet pressures and outlet pressure settings. Flows are shown in SCFH (at 60°F and 14.7 psia) and in Nm³/h (at 0°C and 1.01325 bar) of air.

Note

The 67C Series Regulators may be sized for 100% flow using capacities as shown in Table 4. It is not necessary to reduce published capacities.

67C Series

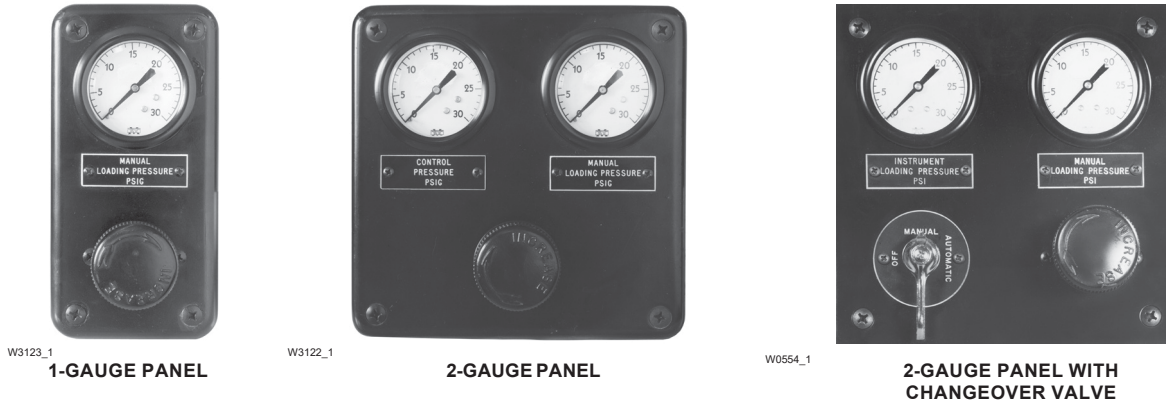

Figure 3. 670 Series Typical Panel Layouts

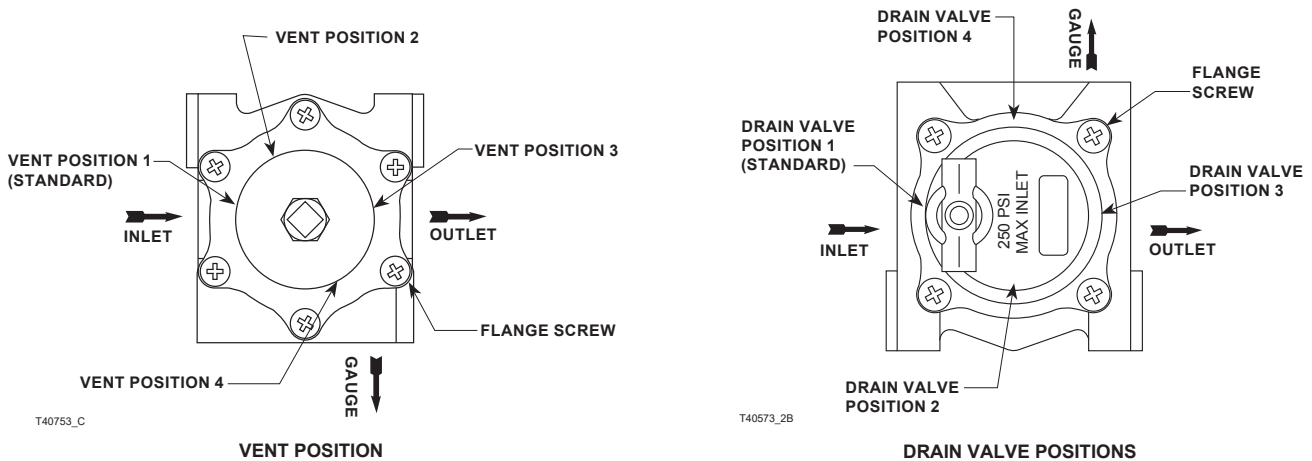

Figure 4. 67C Series Vent and Drain Valve Positions

To determine the equivalent capacities for other gases, multiply the table capacity by the following appropriate conversion factor: 1.29 for 0.6 specific gravity natural gas, 0.810 for propane, 0.707 for butane or 1.018 for nitrogen. For gases of other specific gravities, divide the table capacities by the square root of the appropriate specific gravity. To find wide-open flow capacities for relief sizing at any inlet pressure, perform one of the following procedures. Then, if necessary, convert using the factors provided above.

For critical pressure drops (absolute outlet pressure equal to or less than one-half of absolute inlet pressure), use the following formula:

$$Q = (P_1)(C_g)$$

For pressure drops lower than critical (absolute outlet pressure greater than one-half of absolute inlet pressure), use the following formula:

where,

$$Q = \sqrt{\frac{520}{GT}} C_g P_1 \text{SIN} \left(\frac{3417}{C_1} \sqrt{\frac{\Delta P}{P_1}} \right) \text{ DEG}$$

- Q = gas flow rate, SCFH
- P₁ = absolute inlet pressure, psia (P₁ gauge + 14.7)
- C_g = gas sizing coefficient
- G_g = specific gravity of the gas
- T = absolute temperature of gas at inlet, °Rankine
- C₁ = flow coefficient (C_g ÷ C_v)
- ΔP = pressure drop across the regulator, psi

Then, if capacity is desired in normal cubic meters per hour (at 0°C and 1.01325 bar), multiply SCFH by 0.0268.

670 Series Panel-Mounted Loading Regulators (Figure 3)

The 670 Series Panel-Mounted Loading Regulators are compact, rugged units used primarily for manually loading pressure-balanced gas regulators and providing manual control for diaphragm actuator control valves. Applications include remote control of gas pressure to burners in refineries, power plants and various process furnaces.

Table 4. 67C Series Flow Capacities

OUTLET PRESSURE RANGE, SPRING PART NUMBER AND COLOR CODE	OUTLET PRESSURE		INLET PRESSURE		CAPACITIES IN SCFH / Nm ³ /h OF AIR							
					Types 67C, 67CR, 67CS and 67CSR				Types 67CF, 67CFR, 67CFS and 67CFSR			
					10% Droop		20% Droop		10% Droop		20% Droop	
	psig	bar	psig	bar	SCFH	Nm ³ /h	SCFH	Nm ³ /h	SCFH	Nm ³ /h	SCFH	Nm ³ /h
0 to 35 psig / 0 to 2.4 bar T14059T0012 (Silver) T14113T0012 (Silver stripe)	15	1.0	50	3.4	250	6.7	430	11.5	250	6.7	430	11.5
			75	5.2	340	9.1	610	16.3	300	8.0	690	18.5
			100	6.9	430	11.5	800	21.4	330	8.8	1000	26.8
			150	10.3	680	18.2	1200	32.2	400	10.7	1600	42.9
			250	17.2	1300	34.8	1900	50.9	450	12.1	1800	48.2
			400	27.6 ⁽¹⁾	390	10.5	1850	50.0	----	----	----	----
	20	1.4	50	3.4	310	8.3	460	12.3	350	9.4	500	13.4
			75	5.2	420	11.3	700	18.8	530	14.2	820	22.0
			100	6.9	620	16.6	940	25.2	750	20.1	1100	29.5
			150	10.3	960	25.7	1450	38.9	1400	37.5	1600	42.9
			250	17.2	1550	41.5	2150	57.6	2550	68.3	2700	72.4
			400	27.6 ⁽¹⁾	1200	32.2	2750	73.7	----	----	----	----
35	2.4	50	3.4	390	10.5	490	13.1	390	10.4	500	13.4	
		75	5.2	590	15.8	850	22.8	640	17.2	820	22.0	
		100	6.9	770	20.6	1150	30.8	840	22.5	1100	29.5	
		150	10.3	1200	32.2	1750	46.9	1450	38.9	1650	42.9	
		250	17.2	2200	58.9	2700	72.4	2450	65.7	2700	72.4	
		400	27.6 ⁽¹⁾	2850	76.4	3450	92.5	----	----	----	----	
0 to 60 psig / 0 to 4.1 bar T14058T0012 (Blue stripe) T14114T0012 (Blue)	35	2.4	50	3.4	310	8.3	440	11.8	330	8.8	470	12.6
			75	5.2	440	11.8	670	18.0	500	13.4	730	19.6
			100	6.9	560	15.0	900	24.1	700	18.8	1000	26.8
			150	10.3	780	20.9	1350	36.2	1050	28.1	1550	41.5
			250	17.2	1450	38.9	2200	59.0	2000	53.6	2600	69.7
			400	27.6 ⁽¹⁾	770	20.6	2500	67.0	----	----	----	----
	60	4.1	75	5.2	520	13.9	720	19.3	520	13.9	720	19.3
			100	6.9	750	20.1	1050	28.1	770	20.6	1000	26.8
			150	10.3	1100	29.5	1700	45.6	1100	29.5	1600	42.9
			250	17.2	2050	54.9	2850	76.4	2450	65.7	2750	73.7
			400	27.6 ⁽¹⁾	3200	85.8	4300	115	----	----	----	----
			----	----	----	----	----	----	----	----	----	----
0 to 125 psig / 0 to 8.6 bar T14060T0012 (Red stripe) T14115T0012 (Red)	80	5.5	100	6.9	500	13.4	800	21.4	530	14.2	780	20.9
			150	10.3	750	20.1	1200	32.2	780	20.9	1200	32.2
			250	17.2	1200	32.2	2050	54.9	1250	33.5	2200	59.0
	125	8.6	150	10.3	900	24.1	1250	33.5	900	24.1	1150	30.8
			250	17.2	1560	41.8	2450	65.7	1650	44.2	2450	65.7
			400	27.6 ⁽¹⁾	2200	59.0	4350	117	----	----	----	----
0 to 150 psig / 0 to 10.3 bar ⁽²⁾ 10C1730X012 (Black)	80	5.5	250	17.2	550	14.7	1200	32.2	550	14.7	1200	32.2
			400	27.6 ⁽¹⁾	400	10.7	1100	29.5	----	----	----	----
	135	9.3	250	17.2	970	26.0	1800	48.2	1100	29.5	1800	48.2
			400	27.6 ⁽¹⁾	840	22.5	2350	63.0	----	----	----	----
	150	10.3	250	17.2	1100	29.5	1850	49.6	1100	29.5	1850	49.6
			400	27.6 ⁽¹⁾	940	25.2	2500	67.0	----	----	----	----

1. Inlet pressures above 250 psig / 17.2 bar with a maximum of 400 psig / 27.6 bar are only available on Types 67CS and 67CSR.
2. Available for Types 67CS, 67CSR, 67CFS and 67CFSR only.

Three basic panels are available within the product line, each having one 67C Series Pressure Regulator connected to one or two gauges and a changeover valve.

A single gauge typically shows loading pressure to the control valve. For more information, see Bulletin 62.3:670.

NACE Universal Compliance

Optional materials are available for applications handling sour gases. These constructions comply with the recommendations of NACE International sour service standards.

The manufacturing processes and materials used by Emerson assure that all products specified for sour gas service comply with the chemical, physical and metallurgical requirements of NACE MR0175 and/or NACE MR0103.

Customers have the responsibility to specify correct materials. Environmental limitations may apply and shall be determined by the user.

Ordering Information

When ordering, complete the Ordering Guide on pages 11 and 12. Refer to the Specifications section on page 2. Review the description to the right of each specification and the information in each referenced table or figure. Specify your choice whenever a selection is offered.

67C Series

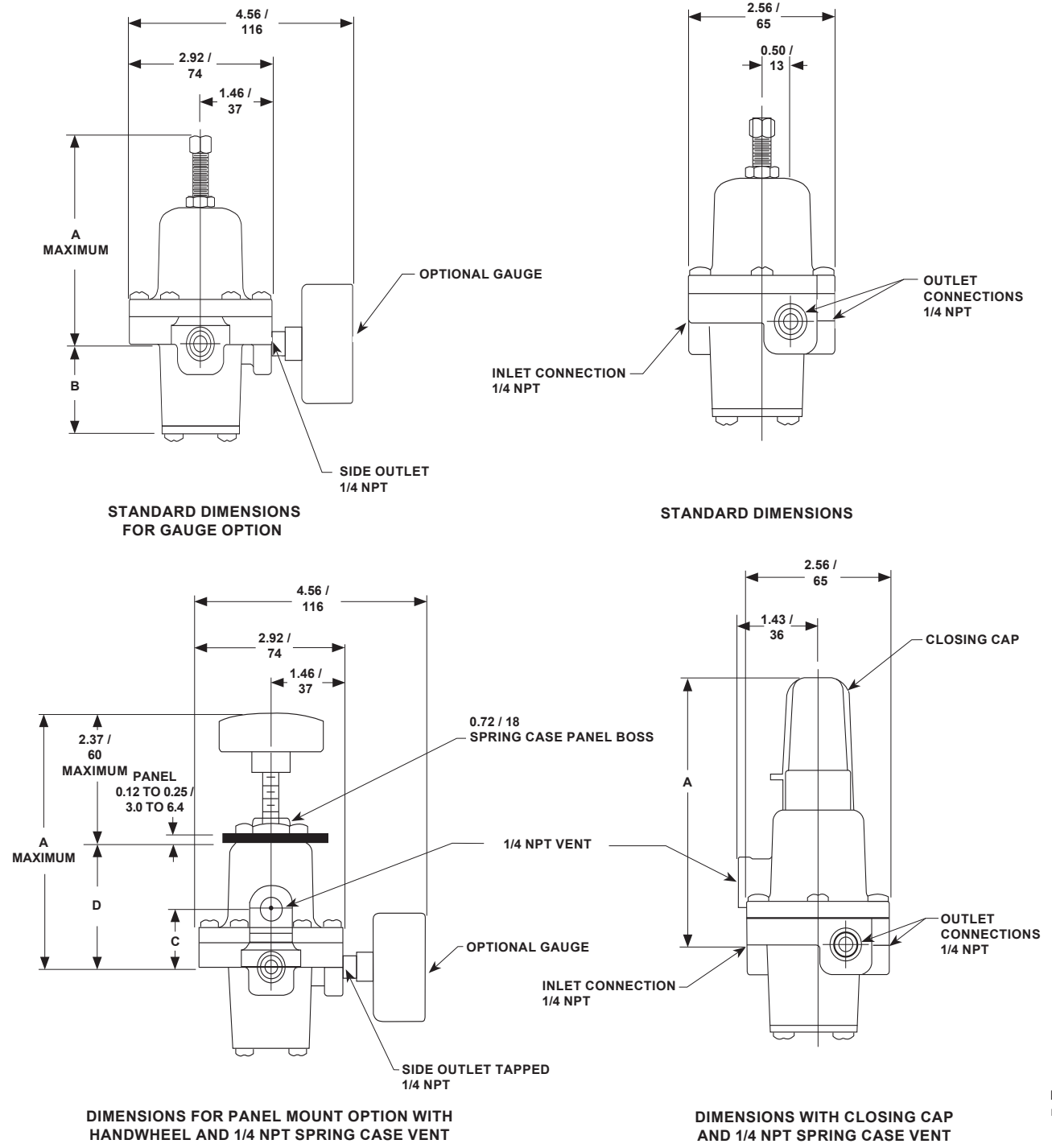

Figure 5. Types 67C, 67CR, 67CS and 67CSR Dimensions

Table 5. Types 67C, 67CR, 67CS and 67CSR Dimensions

TYPE	STANDARD DIMENSION				DIMENSION WITH CLOSING CAP		PANEL MOUNT OPTION WITH HANDWHEEL DIMENSION					
	A		B		A		A		C		D	
	In.	mm	In.	mm	In.	mm	In.	mm	In.	mm	In.	mm
67C and 67CR	3.50	89	1.51	38	4.60	117	4.69	119	1.08	27	2.33	59
67CS and 67CSR	4.13	105	1.62	41	4.93	125	5.00	127	1.14	29	2.65	67

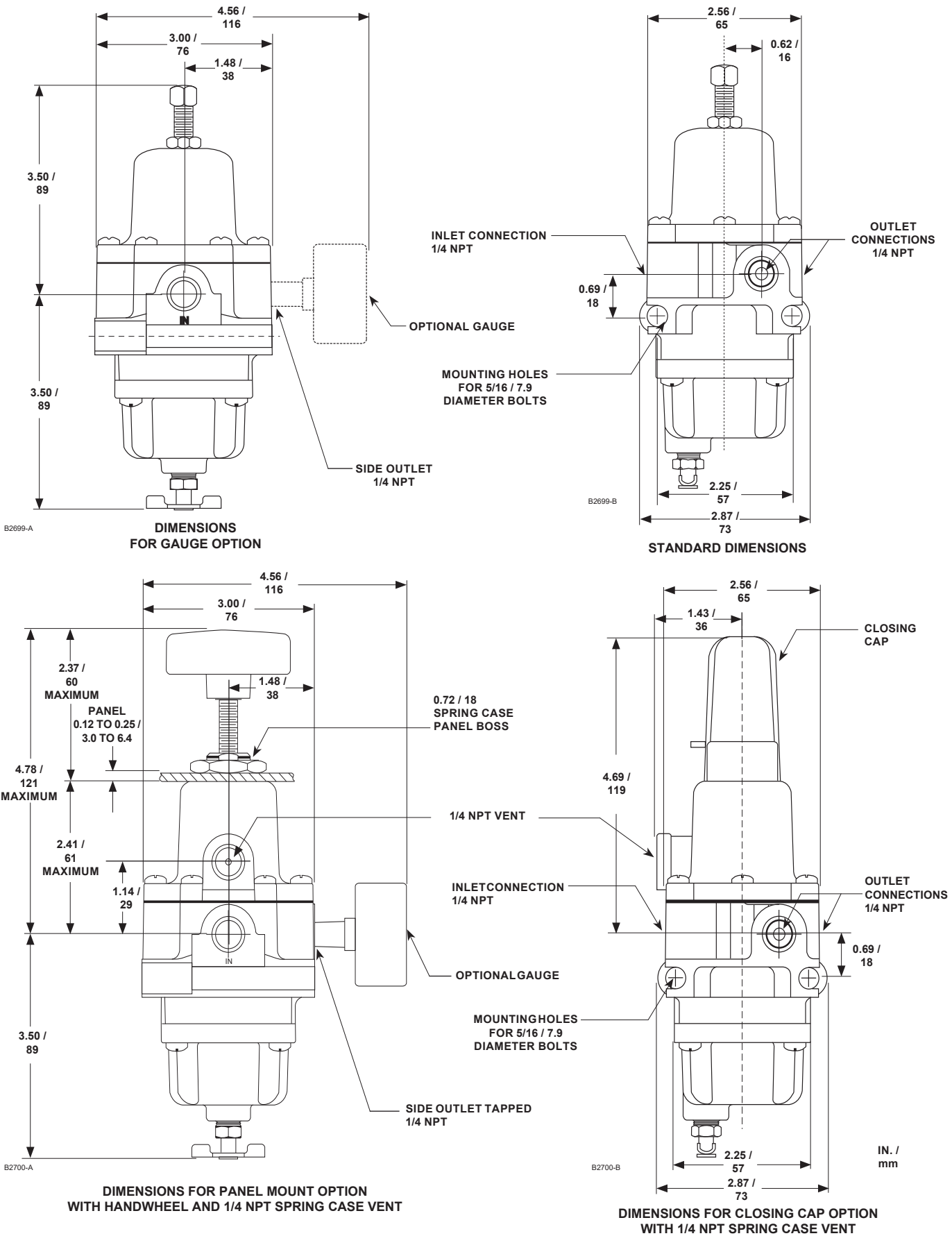

Figure 6. Types 67CF and 67CFR Dimensions

67C Series

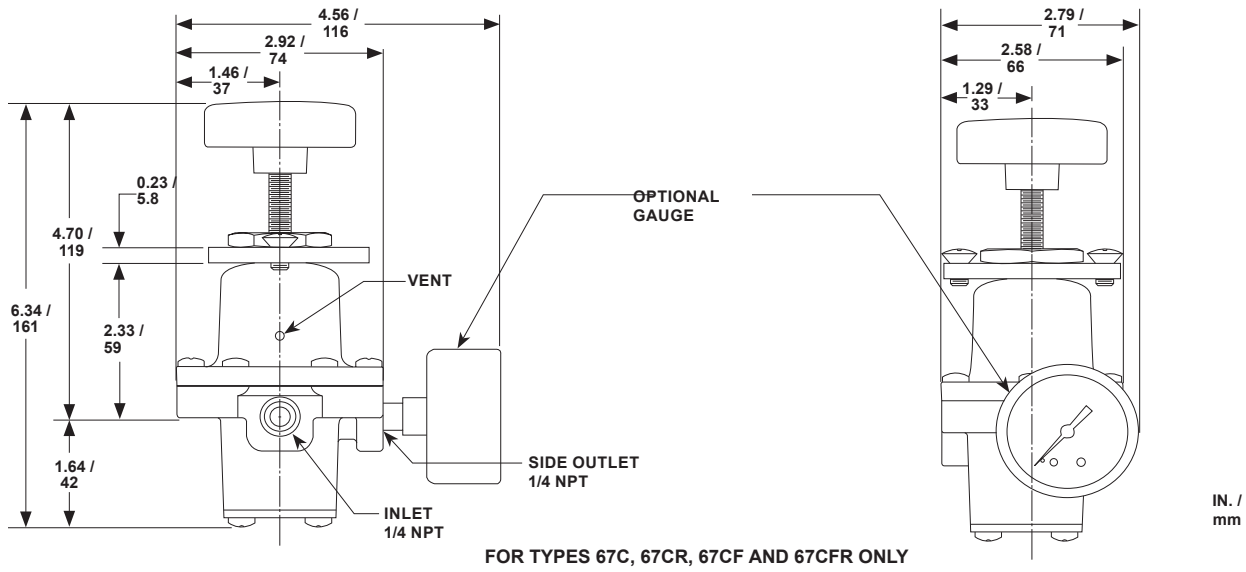

Figure 7. Dimensions for 3-Hole Panel Mount Option With Handwheel and 1/4 NPT Spring Case Vent

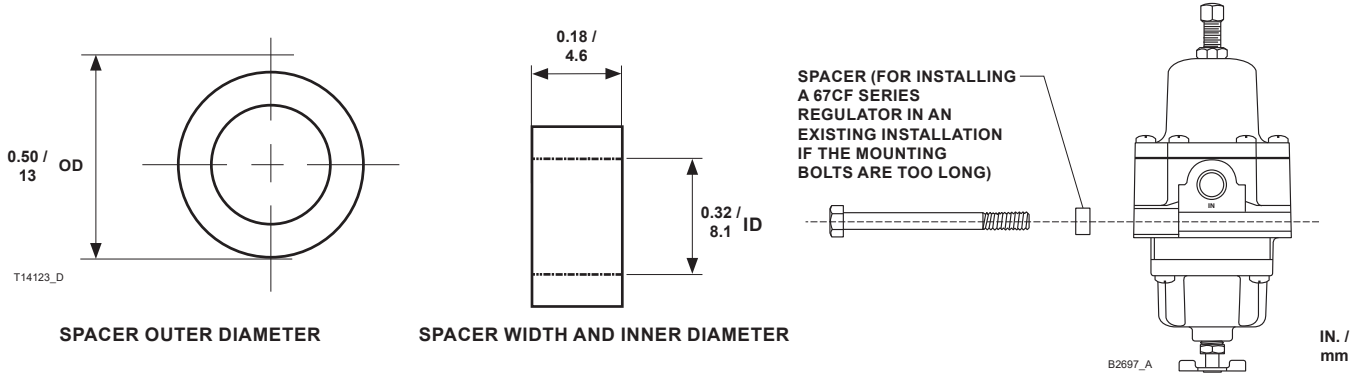

Figure 8. Spacer Dimensions and Installation Schematic

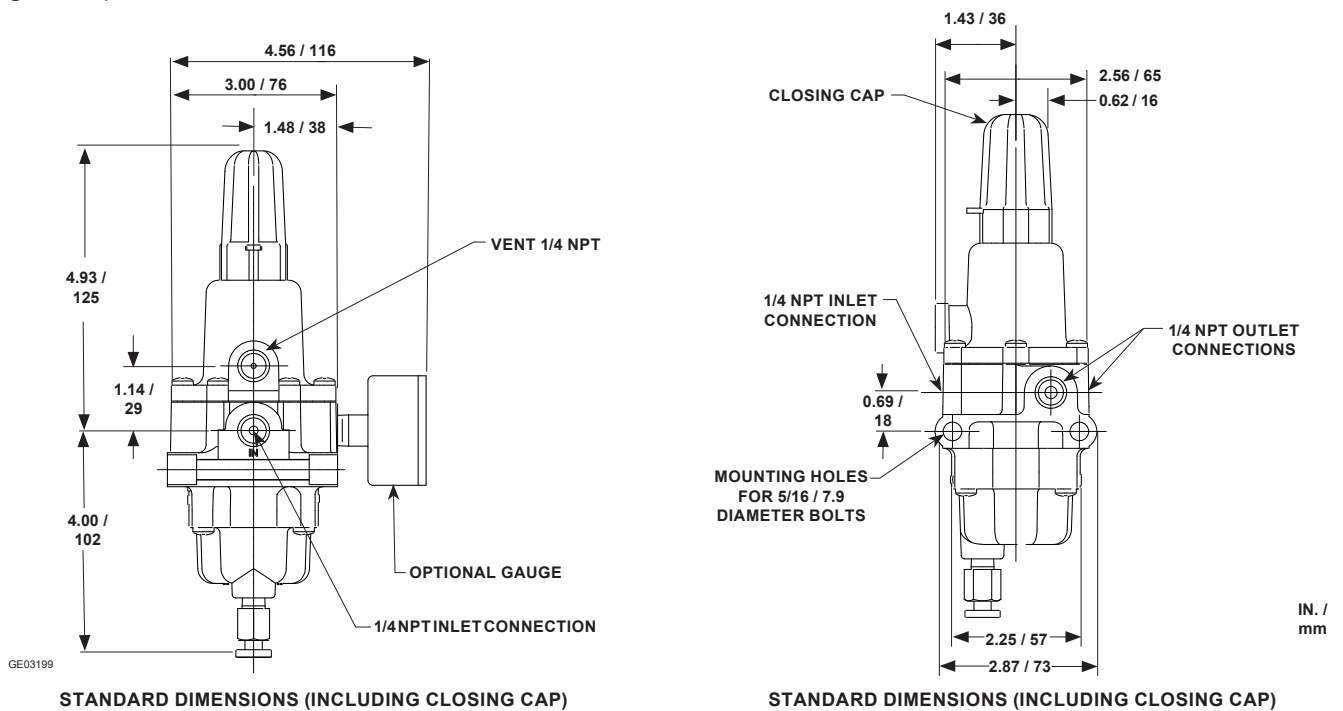
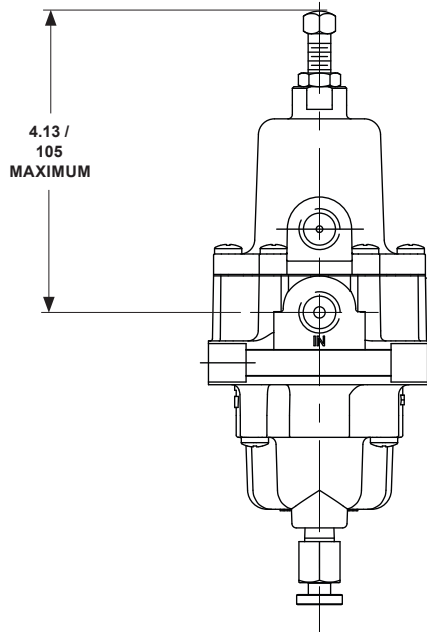
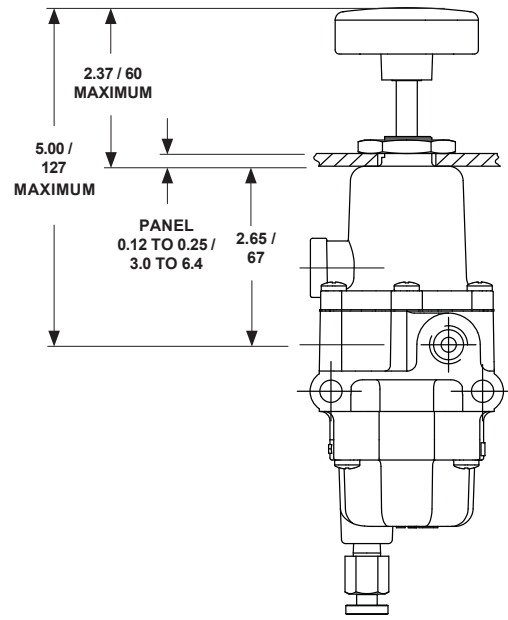

Figure 9. Types 67CFS and 67CFSR Dimensions



DIMENSIONS WITHOUT CLOSING CAP



DIMENSIONS FOR PANEL MOUNT OPTION WITH HANDWHEEL

IN. /
mm

GE03268

Figure 9. Types 67CFS and 67CFSR Dimensions (continued)

Ordering Guide

Type (Select One)

- 67C (Aluminum without internal relief)***
- 67CR (Aluminum with internal relief)***
- 67CS (Stainless steel without internal relief)***
- 67CSR (Stainless steel with internal relief)***
- 67CF (Aluminum with filter and without internal relief)***
- 67CFR (Aluminum with filter and internal relief)***
- 67CFS (Stainless steel with filter and without internal relief)***
- 67CFSR (Stainless steel with filter and internal relief)***

Quantity (Specify) _____

Spring Case Style (Select One)

- Drilled hole vent (Types 67C, 67CR, 67CF and 67CFR **standard**)***
- 1/4 NPT vent (Types 67CS, 67CSR, 67CFS and 67CFSR **standard**)***
- Single hole panel mount***
- 3-hole panel mount (Types 67C, 67CR, 67CF and 67CFR only)***

Adjusting Screw (Select One)

- Square head (Types 67C, 67CR, 67CF and 67CFR **standard**)***
- Square head with closing cap (Types 67CS, 67CSR, 67CFS and 67CFSR **standard**)***
- Handwheel***

Outlet Pressure Range (Select One)

- 0 to 20 psig / 0 to 1.4 bar***
- 0 to 35 psig / 0 to 2.4 bar***
- 0 to 60 psig / 0 to 4.1 bar***
- 0 to 125 psig / 0 to 8.6 bar***
- 0 to 150 psig / 0 to 10.3 bar (Types 67CS, 67CSR, 67CFS and 67CFSR only)***

Diaphragm, O-Rings and Valve Plug (Select One)

- Nitrile (NBR) (**standard**)***
- Fluorocarbon (FKM)**
- Silicone (VMQ) diaphragm, O-rings and Nitrile (NBR) valve plug*

Filter Material (Select One)

- Polyethylene (5 microns) (**standard**)***
- Glass (5 microns)***
- Stainless steel (40 microns)***

Dripwell

- Standard
- Large capacity with manual drain valve
- Large capacity with automatic drain valve, Nitrile (NBR)
- Large capacity with automatic drain valve, Fluorocarbon (FKM)

Drain Valve (for Manual Drain Only) (Select One)

- Brass (Types 67CF and 67CFR **standard**)***
- Stainless steel (Types 67CFS and 67CFSR **standard**)***

Drain Valve Location (for Standard Dripwell Only) (Select One)

- Position 1 - Aligned with inlet (**standard**)***
- Position 2
- Position 3
- Position 4

Spring Case Vent Location (Select One)

- Position 1 - Aligned with inlet (**standard**)***
- Position 2
- Position 3
- Position 4

- continued -

67C Series

Ordering Guide (continued)

Fixed Bleed for Type 67CR, 67CSR, 67CFR or 67CFSR (Optional)

Yes**

Smart Bleed™ Internal Check Valve Airset for Types 67CFR and 67CFSR (Optional)

Yes**

Second Outlet (Select One)

- Open (Types 67C, 67CR, 67CF and 67CFR standard)***
- Plugged with pipe plug (Types 67CS, 67CSR, 67CFS and 67CFSR standard)***
- Tire Valve***
- Pressure Gauge (see below)

Triple Scale Pressure Gauge (Optional)

- Brass Gauge** or **Stainless Steel Gauge**
 - 0 to 30 psig / 0 to 0.2 MPa / 0 to 2.1 bar***
 - 0 to 60 psig / 0 to 0.4 MPa / 0 to 4.1 bar***
 - 0 to 160 psig / 0 to 1.1 MPa / 0 to 11.0 bar***

NACE MR0175 Construction (Optional)⁽¹⁾

Yes (not available with gauge)**

1. Product complies with the material requirements of NACE MR0175. Environmental limits may apply.

Regulators Quick Order Guide	
***	Readily Available for Shipment
**	Allow Additional Time for Shipment
*	Special Order, Constructed from Non-Stocked Parts. Consult your local Sales Office for Availability.
Availability of the product being ordered is determined by the component with the longest shipping time for the requested construction.	

NACE MR0103 Construction (Optional)

Yes (not available with gauge)**

Replacement Parts Kit (Optional)

Yes, send one replacement parts kit to match this order.

Specification Worksheet

Application (Please designate units): _____

Specific Use _____

Line Size _____

Gas Type and Specific Gravity _____

Gas Temperature _____

Does the Application Require Overpressure Protection?

Yes No If yes, which is preferred:

Relief Valve Monitor Regulator

Shutoff Device

Is overpressure protection equipment selection assistance desired?

Pressure (Please designate units):

Maximum Inlet Pressure (P_{1max}) _____

Minimum Inlet Pressure (P_{1min}) _____

Downstream Pressure Setting(s) (P_2) _____

Maximum Flow (Q_{max}) _____

Performance Required:

Accuracy Requirements? _____

Need for Extremely Fast Response? _____

Other Requirements:

✉ Webadmin.Regulators@emerson.com

Facebook.com/EmersonAutomationSolutions

🔍 Fisher.com

LinkedIn.com/company/emerson-automation-solutions

X.com/EMR_Automation

Emerson

Americas

McKinney, Texas 75069 USA
T +1 800 558 5853
+1 972 548 3574

Europe

Bologna 40013, Italy
T +39 051 419 0611

Asia Pacific

Singapore 128461, Singapore
T +65 6777 8211

Middle East and Africa

Dubai, United Arab Emirates
T +971 4 811 8100

D102656X012 © 2001, 2025 Emerson Process Management Regulator Technologies, Inc. All rights reserved. 07/25.
Fisher™ is a mark owned by Fisher Controls International, LLC, an Emerson Company. The Emerson logo is a trademark and service mark of Emerson Electric Co. All other marks are property of their respective owners.

Neither Emerson nor any of its affiliated entities assume responsibility for the selection, use or maintenance of any product. Responsibility for proper selection, use, and maintenance of any product remains solely with the purchaser and end user.

The contents of this publication are presented for informational purposes only and while every effort has been made to ensure their accuracy, they are not to be construed as warranties or guarantees, express or implied, regarding the products or services described herein or their use or applicability. All sales are governed by our terms and conditions, which are available upon request. We reserve the right to modify or improve the designs or specifications of such products at any time without notice.

