

Fully integrated solutions for total tank protection



Tank Management Catalog
Advancing safety, emissions control and
maintaining product integrity.



Your tank pressure suddenly increases and you don't know why

The safety of your personnel relies on an effective emergency preparedness plan. While protecting your employees, you also have the added pressure making certain you don't lose any assets. Over and under pressurization of your tanks can lead to damage or even failure, so ensuring all pressure setpoints are correct and compatible becomes your mission 24/7.

The risks are great

Abnormal conditions can lead to an emergency event like an external fire, explosion damage and equipment failure. Protecting your personnel cannot take second place. You need to carefully consider the quality and value of the products you choose to protect your assets. When something does go wrong, you need fast information about all of your assets so you can quickly respond for a quick resolution.

“The average hourly cost of facility downtime is approximately \$12,500, but substantially higher at many continuous process facilities.”
– ABC Advisory Group



“In fiscal year 2015, EPA enforcement actions required companies to invest \$7 billion in actions and equipment to control pollutions and clean up contaminated sites....”
–U.S. EPA, Enforcement Annual Results for Fiscal Year (FY) 2015



Low Cost-to-Protection Ratio

Protect your investment. Proper venting and safety equipment costs only a small fraction of total capital expenditure required for building and installing storage tank facilities.

Protecting what you have

Unexpected downtime due to system failure costs time and money to repair and puts the integrity of your tanks and their content at risk. You not only need to extend the life of your hard assets but also the integrity of your gaseous and liquid assets. Minimizing oxidation and maintaining optimal tank pressure to reduce contamination is vital in preserving product integrity.

Optimal emissions control is not only to comply to the latest environmental regulations but limits product loss. This is achieved through accurate pressure control and a knowledgeable partner that can help you manage your total tank protection needs.

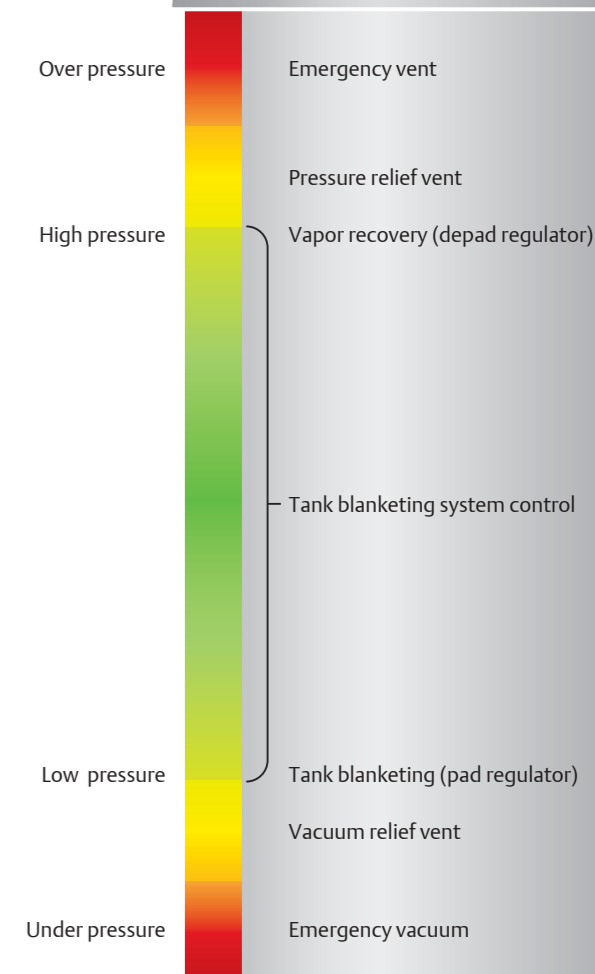

Reduce emissions, limit product loss and protect the integrity of the products in your tanks



- **Reduce emissions and product loss by 15%⁽¹⁾** - This exceeds the most stringent standards for allowable leakage and provides excellent setpoint accuracy.
- **Reduce maintenance and improve service life** - Vents feature replaceable seats and arrestors that are easier to clean.
- **Reduce system cost** - Arrestors that are designed with flame cell openings that are 3 times larger than others in the industry, reducing pressure drop and blower cost.
- **Reduce your tank blanketing expense by 50%⁽²⁾** - Regulators that provide low-setpoint technology which allows only the amount of blanketing gas required, delivered to the tank, minimizing this expense.

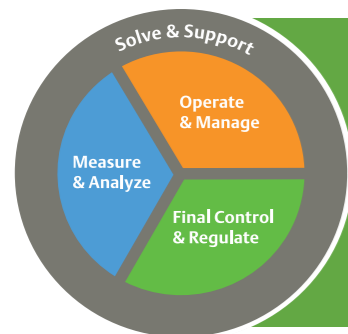

Emerson, the world leader in total tank management technology, provides the products, engineering and service that successful tank management requires. Fully integrated solutions advance safety, control emissions and maintain the integrity of tank contents.

Actuation • Control Valves • Isolation Valves
Regulators & Relief Valves • Valve and Instrumentation & Accessories

1. Based on 1 SCFH leakage at 90% setpoint vs. standard 1 SCFH leakage at 75% setpoint.
2. Based on lowering the tank blanketing regulator setpoint from 2 to 1-in. w.c. pressure.



Reduce risk while increasing awareness and response time with wireless monitoring.

Gain visibility to prevent problems

Emerson's wireless-ready tank monitoring equipment detect device and system malfunctions in advance, to help reduce your risk of equipment damage and operational emergencies. Expanded data collection capabilities can help improve operational efficiencies, lower costs and aid in making more informed decisions.

- Monitor tanks from the safety of a remote control room
- Reduce the need to climb tanks to monitor gauges
- Monitor regulator functions and receive malfunction notifications
- Respond immediately to safety and emissions events
- Monitor and control opening and closing of emergency pressure vacuum vents
- Detect the opening of pressure vacuum relief valves and the presence of flames
- Trace and compare nitrogen costs





“My tanks and the contents inside them are extremely valuable.”

Total tank protection from a single source

Emerson’s Integrated Protection Solutions merges industry leading tank blanketing and vapor recovery regulators with top-rated flame arrestors, pressure-vacuum relief valves, emergency vents and tank hatches to deliver seamless compatibility. It’s the latest step in our ability to provide the widest possible array of environmental protection and safety equipment, expertise and unparalleled service across a full range of oil and gas, chemical and other industries worldwide.

Achieve optimal safety for your employees, assets and products around the globe with fully integrated solutions from Emerson, your single source for total tank protection.

Integrated, scalable solutions to fit your specific needs

Rely on expertise to help you create a total tank protection solution that optimizes operational efficiencies.

Solve operational challenges

Mismatched and incompatible multi-vendor systems long have been an obstacle for companies seeking total tank protection, putting employee safety, asset protection and product integrity at risk. Regulatory compliance tied to emissions control and environmental protection also becomes increasingly difficult and often costly to achieve.

Turning such complex challenges into simple, integrated solutions that increase safety and reduce risk requires uncompromising application experience and expertise.

Emerson helps you overcome operational challenges inside and out with Integrated Protection Solutions.

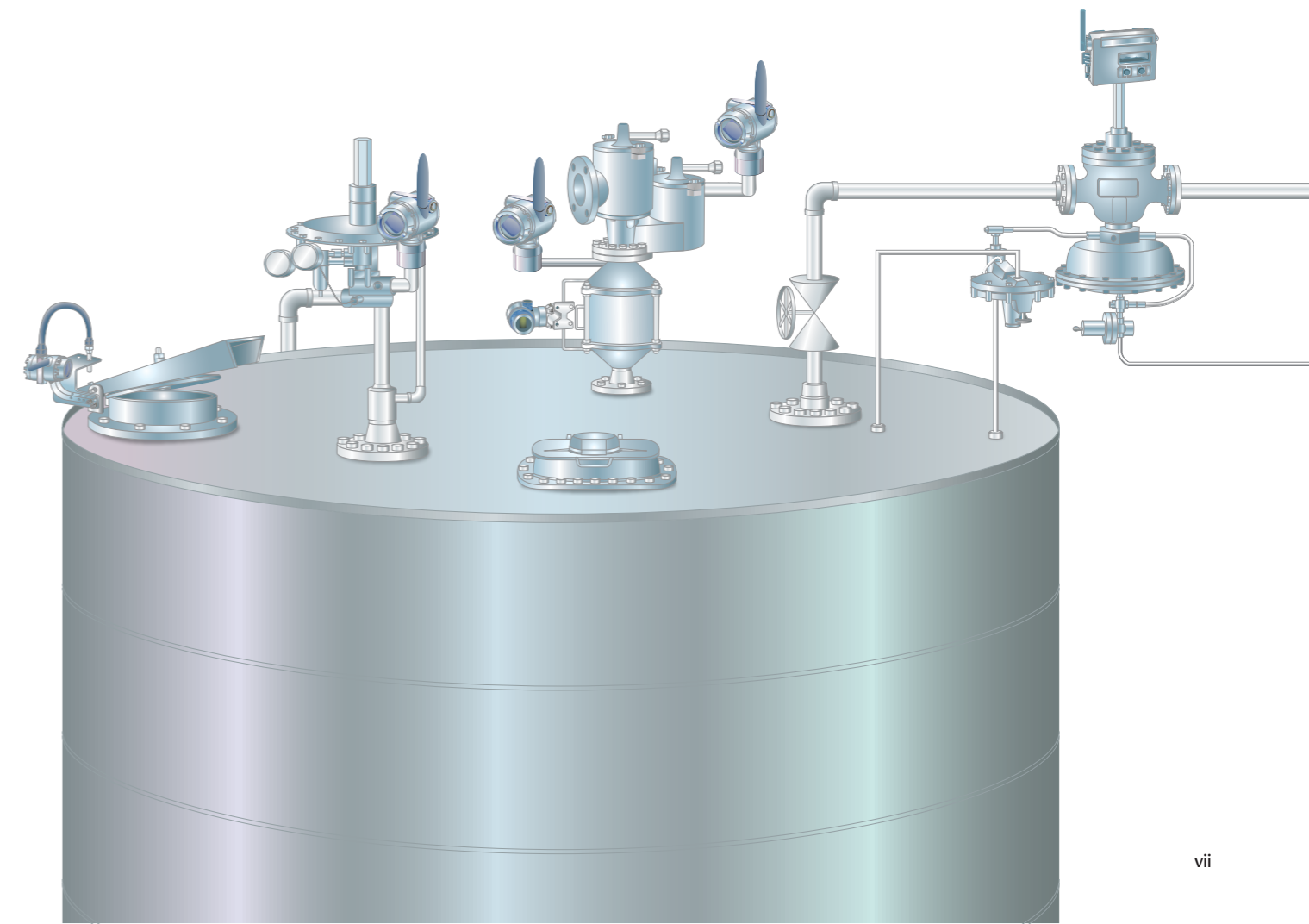

Sizing Program

Sizing Flame Arrestors, Relief Valves, Relief Vents and Hatches

ENARDO™ Soft Calc II is our next-generation product sizing program with new capabilities that include API 2000 7th Edition breathing calculations, selections for PVRV/ arrestor combinations and more. Designed from the customer's point of view, Soft Calc II is an intuitive, user-friendly sizing program that simplifies selection and specification of venting products.

- Sizing Per ISO 28300/ API 2000 7th Edition, including Annex A
- Size New Equipment Quickly
- Verify Existing Installations
- User Friendly
- Produce Project Specification Sheets
- Check Pressure Drops
- Produce Flow Curves at Relief Points
- Unit Conversion Calculations



Sizing for:

- Flame Arrestors
- Pressure Vacuum Relief Vents
- Emergency Relief Vents
- Valve/Arrestor Combinations
- Tank Gauge Hatch Products

ENARDO Model 950 End Of Line Valve		
Tank Data and Specification Sheet		
Value Information		Value Options or Other Information
1	Question Number	Model 950 2011
2	Date	08/26/2011
3	Serial Number	000
4	Model Number	950-4-111-1.0-014-01
5	Inventory	
General Information		
6	Customer Name	
7	Project Name	
8	Project Number	
9	Location	
10	Tank Number	
11	Valve Tag Number	Regist
12	Classification	
13	Engineer Name	
Tank Design Information per API 2000 7th Edition		
14	Tank Capacity	2000 gal
15	Tank MWWT	50 gal/hr
16	Tank MWWT	10 gal/hr
17	Design Pressure	Maximum or Other
18	Design Storage Temperature	Atmospheric
19	Leakage	Between 02 and 03
Pressure Parameter Information		
20	Backset Valve Failure	0 SCFH
21	Maximum Pump In Rate	300 US Gallons
22	Other	0 SCFH
23	Filling Outbreathing	4.023 SCFH
24	Thermal Outbreathing	1.024 SCFH
25	Other Outbreathing	0 SCFH
26	Total Outbreathing	11.074 SCFH
27	Pressure Setting	4 psig
28	Minimum Pump Out Rate	0 SCFH
29	Other	0 SCFH
Vacuum Parameter Information		
30	Maximum Pump Out Rate	0 US Gallons
31	Other	0 SCFH
32	Emptying Inbreathing	2.466 SCFH
33	Thermal Inbreathing	0.216 SCFH
34	Other Inbreathing	0 SCFH
35	Total Inbreathing	0.682 SCFH
36	Vacuum Setting	4 in.Hg
37	Total Vacuum Tank	0.52 in.Hg
38	% of Tank MWWT	0
Valve Design Information		
39	Connection Size	4Nipples
40	Design Size	4" Nipples
41	Design Size	4" Nipples
42	Body Material	Aluminum
43	End Connection	RF
44	Valve Seal Material	316 Sulfur
45	Internal Seal Material	316 Sulfur
46	Body Sealant Material	Zinc Phosphate
47	Flare/Welding Material	Zinc Phosphate
48	CS Temperature	900 Degrees F
49	Maximum Minimum Design Temperature	000 200F
50	Maximum Minimum Design Pressure	0.50 100psi
Valve Requirements		
51	Removable Seal Gaskets	Required
52	Minimum Leakage Rate	1.0 SCFH @ 95% Set Pressure
53	Confined Space	Required
54	Self-Closing/Drift Stop	Required

Table of Contents

Product Overview

Flame and Detonation Arrestors.....	2
Pressure and Vacuum Relief Valves	3
Vent Valves and Emergency Vents	4
Gauge and Thief Hatches	5
Tank Blanketing and Vapor Recovery Regulators	6

Flame and Detonation Arrestors

Flame and Detonation Arrestors	9
Flame Arrestor Technology.....	10
Gas Group Chart	24
Enardo™ IL Series, Threaded Inline	25
Enardo 8800/Enardo 9900 Series, Vent Stack	27
Enardo FVFA Series, Free Vent	29
Enardo 7 Series, Deflagration.....	32
Enardo 8 Series, High Pressure Deflagration	36
Enardo DFA Series, Detonation	38
Standard Flame Arrestor Selection Criteria	41
ATEX Certified Flame Arrestor Selection Criteria	42
Flame Arrestor Certifications.....	43
Flame Arrestor Design and Application Data Sheet	45

Pressure Vacuum Relief Valves

Pressure Vacuum Relief Valves	47
Pressure Vacuum Relief Valve Design and Application Data Sheet	48
Enardo 800-SO, In-Line	49
Enardo 800-PSO, In-Line.....	51
Enardo 900-SO, End-of-Line Stack	53
Enardo ES-805-SO, In-Line	55
Enardo ES-805-PSO, In-Line	57
Enardo ES-905-SO, End-of-Line Stack	59
Enardo ES-905-PSO, End-of-Line Stack	61
Enardo ES-850/Enardo ES-950, Pressure Vacuum	63
Enardo ES-850, Pipe Away	65
Enardo ES-950, Vent to Atmosphere	67
Enardo 850, Pipe Away	69
Enardo 950, Vent to Atmosphere	71
Enardo 850 and Enardo 950, Wireless Monitoring	73
Enardo 851, Top Mount or Side Mount	74
Enardo 951, Top Mount	76
Enardo 952, Top Mount.....	78
Enardo 953, Side Mount	80
Marine Vapor Control System, PVRV	82
Enardo 860, Spring Loaded	85
Enardo 960, Spring Loaded	87
Enardo 961, Spring Loaded.....	89

Emergency Vents and Free Vents

Emergency Vents and Free Vents	91
Emergency Pressure Relief Vent Design and Application Data Sheet.....	92
Enardo 2000, Emergency Relief Vent.....	93
Enardo 2000, Wireless Monitoring.....	95
Enardo 2100, Emergency Relief Vent.....	96
Enardo 2500, Emergency Relief Vent with Vacuum	98
Enardo 4000 / Enardo 4100, Free Vents.....	100

Gauge and Thief Hatches

Gauge and Thief Hatches	103
Gauge and Thief Hatches Introduction	104
Enardo A, A-L and 200, Dead Weight Hatches	106
Enardo 1000, Lock Down Hatch	109
Enardo 660 and Enardo 660-L, Thief Hatch	110
Enardo 660B and Enardo 660-LB, Thief Hatches	112
Enardo ES-660 and Enardo ES-660-L, Thief Hatches	114
Enardo ES-660-B and Enardo ES-660-LB, Thief Hatches ...	116
Enardo ES-660-HF, Thief Hatches.....	118
Enardo ES-665, Thief Hatches	120

Tank Blanketing and Vapor Recovery Regulators

Tank Blanketing and Vapor Recovery Applications	124
T205 Series, Tank Blanketing.....	131
Type T205B, Tank Blanketing.....	149
Type Y692, Tank Blanketing	161
Type Y693, Tank Blanketing	167
ACE95 Series, Tank Blanketing	173
Type 1190, Tank Blanketing	177
T208 Series, Vapor Recovery	183
Type 1290, Vapor Recovery	189

Technical Data

Technical Data	195
Conversion Factors.....	196
150 lb. Flanges, ANSI B16.5 Standard.....	198
API Flanges.....	199
DIN PN 10 Flanges.....	200
JIS PN 10K Flanges	201
Conversion Chart of Pressure and Vacuum Settings	202

Flame and Detonation Arrestors

Deflagration Flame Arrestors Enardo™ 7 Series



- Concentric/Eccentric
- Bi-Directional Design
- Size 1 to 36 in. / 25 to 900 mm
- Aluminum, Carbon steel, 304 Stainless steel, 316 Stainless steel
- Gas Groups D (IIA), C (IIB3), B (IIC)
- FM Approved-Group D (IIA) Gases 2 to 12 in. / 50 to 300 mm
- ISO-16852 Certified D (IIA), C (IIB3) 1 to 12 in. / 25 to 300 mm

High Pressure Deflagration Flame Arrestors Enardo 8 Series

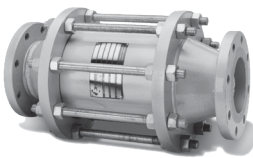

- Concentric/Eccentric
- Bi-Directional Design
- Size 2 to 24 in. / 50 to 600 mm
- Carbon steel, 304 Stainless steel, 316 Stainless steel
- Gas Groups B, C, D

Detonation Flame Arrestors Enardo DFA Series

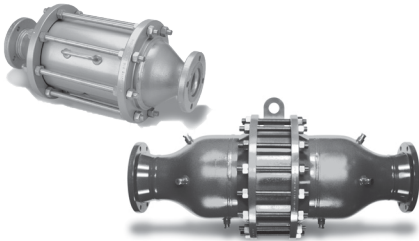

- Concentric/Eccentric
- Bi-Directional Design
- Size 1 to 48 in. / 25 to 1200 mm
- Carbon steel, 304 Stainless steel, 316 Stainless steel
- Gas Groups D (IIA), C (IIB3), B (IIC)
- U.S. Coast Guard Approved D, C 1 to 24 in. / 25 to 600 mm
- ATEX Approved-IIA, IIB3 1 to 24 in. / 25 to 600 mm

Threaded In-line Flame Arrestors Enardo IL Series

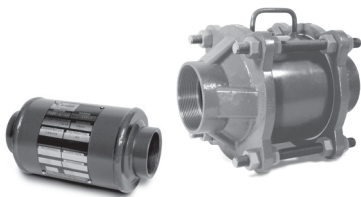

- Bi-Directional Design
- Size 2 to 4 in. / 13 to 100 mm
- Gas Group D (IIA)
- Aluminum, Carbon steel, 304 Stainless steel, 316 Stainless steel

Free Vent Flame Arrestors Enardo FVFA Series



- Size 3/4 to 36 in. / 20 to 900 mm
- Aluminum, Carbon steel, 304 Stainless steel, 316 Stainless steel
- Gas Groups D (IIA), C (IIB3), B (IIC)
- ISO-16852 Certified 2 to 12 in. / 50 to 300 mm D (IIA) and C (IIB3)

Vent Stack Flame Arrestors Enardo 8800, Enardo 9900



- Size 1 to 6 in. / 25 to 150 mm
- Aluminum, Carbon steel, 304 Stainless steel, 316 Stainless steel
- Gas Groups D (IIA)

Features and Benefits

Larger Crimp Size

- Less pressure drop
- Less maintenance
- Easier cleaning

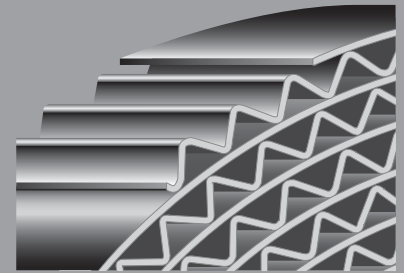

Fluoropolymer Coated Hardware

- Provides outstanding corrosion and chemical resistance

Removable Element

- Easily removable for cleaning and replacement

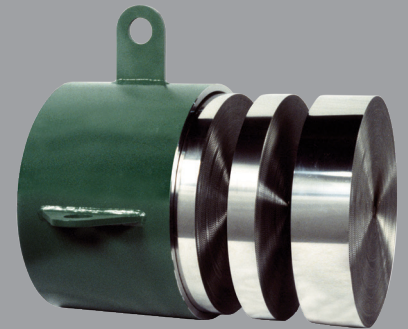

Hinged Element

- Facilitates easy access

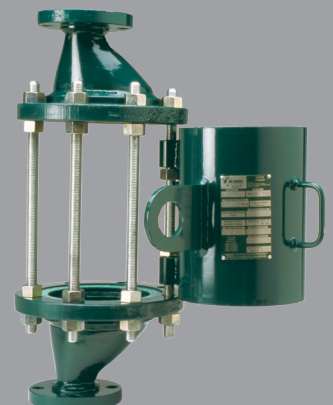

Pressure and Vacuum Relief Valves (PVRV)

Pressure-Vacuum Relief Valve Pipe Away Enardo™ ES-850



- Size: 2 to 12 in. / 50 to 300 mm
- Pressure: 0.5 to 12 oz./sq. in.⁽¹⁾ / 2.0 to 52 mbar⁽¹⁾
- Vacuum: 0.5 to 12 oz./sq. in.⁽¹⁾ / 2.0 to 52 mbar⁽¹⁾
- Aluminum, carbon steel, stainless steel
- EN 13463-1 and EN 13463-5 Certified

1. May be lower for some sizes – consult factory

Pressure-Vacuum Relief Valve Vent-to-Atmosphere Enardo ES-950



- Size: 2 to 12 in. / 50 to 300 mm
- Pressure: 0.5 to 12 oz./sq. in.⁽¹⁾ / 2.0 to 52 mbar⁽¹⁾
- Vacuum: 0.5 to 12 oz./sq. in.⁽¹⁾ / 2.0 to 52 mbar⁽¹⁾
- Aluminum, carbon steel, stainless steel
- EN 13463-1:2001 and EN 13463-5:2003 Certified

1. May be lower for some sizes – consult factory

Pressure-Vacuum Relief Valve Pipe Away Enardo 850, Enardo 850/MVC, Enardo 860



- Size: 2 to 12 in. / 50 to 300 mm
- Pressure: 0.5 to 32.0 oz./sq. in. / 2.0 to 138 mbar
- Vacuum: 0.5 to 32.0 oz./sq. in. / 2.0 to 138 mbar
- Aluminum, carbon steel, stainless steel
- EN 13463-1 and EN 13463-5 Certified

Pressure-Vacuum Relief Valve Vent-to-Atmosphere Enardo 950, Enardo 960



- Size: 2 to 12 in. / 50 to 300 mm
- Pressure: 0.5 to 32.0 oz./sq. in. / 2.0 to 138.0 mbar
- Vacuum: 0.5 to 32.0 oz./sq. in. / 2.0 to 138.0 mbar
- Aluminum, carbon steel, stainless steel
- EN 13463-1 and EN 13463-5 Certified

Pressure Relief Valve Enardo 851, Enardo 951, Enardo 861, Enardo 961

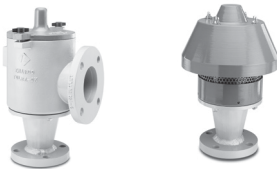

- Size: 2 to 12 in. / 50 to 300 mm
- Pressure: 0.5 to 32.0 oz./sq. in. / 2.0 to 138.0 mbar
- Aluminum, carbon steel, stainless steel
- EN 13463-1 and EN 13463-5 Certified

Pressure Relief Valve Enardo 851, Enardo 952, Enardo 952/MVC, Enardo 953, Enardo 861, Enardo 962, Enardo 963



- Size: 2 to 12 in. / 50 to 300 mm
- Vacuum: 0.5 to 32.0 oz./sq. in. / 2.0 to 138.0 mbar
- Aluminum, carbon steel, stainless steel
- EN 13463-1 and EN 13463-5 Certified

Features and Benefits

Superior Sealing Technology

- Replaceable seat
- Stainless steel pallet with FEP Teflon® seal
- Excellent flow characteristics
- High performance coating for harsh environments

Superior Performance

- Enardo Saber® dual pallet guide system reseats the valve in the same spot each time retaining the valve's seal characteristics

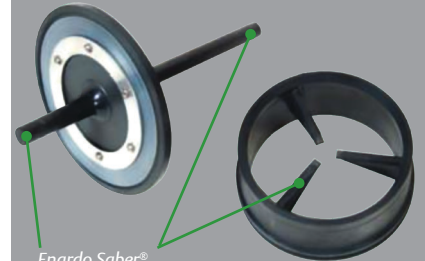

Enardo Saber® Guide System

- Anti-freeze and non-stick design
- Replaceable seat reduces maintenance cost and extends valve life

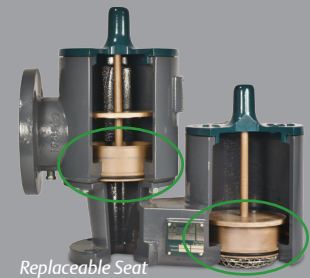

Replaceable Seat

- Advanced composite - Polyphenylene Sulfide (PPS) pallet and seat that provides superior corrosive resistance to chemical attack and non-stick surface

Vent Valves and Emergency Vents

In-Line and Stack Vent Valves

Enardo™ 800-SO, Enardo 800-PSO, Enardo 900-SO



- Size: 2, 3, 4 in. / 50, 80, 100 mm
- Pressure: 1.0 to 16 oz./sq. in. in 0.5 oz./sq. in. increments / 4.3 mbar to 69.0 mbar in 2.2 mbar increments
- Vacuum: 0.4 oz./sq. in. / 1.7 mbar
- Aluminum

In-Line and Stack Vent Valves

Enardo ES-800-SO, Enardo ES-800-PSO, Enardo ES-900-SO

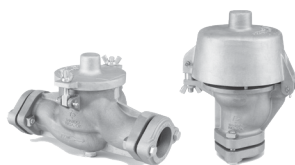

- Size: 2, 3, 4 in. / 50, 80, 100 mm
- Pressure: 1.0 to 16 oz./sq. in. in 0.5 oz./sq. in. increments / 4.3 mbar to 69.0 mbar in 2.2 mbar increments
- Vacuum: 0.4 oz./sq. in. / 1.7 mbar
- Aluminum

Emergency Relief Vent Enardo 2000

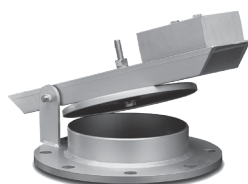

- Size: 4, 8, 10, 12, 16, 18, 20, 24 in. / 100, 200, 250, 300, 400, 450, 500, 600 mm
- Pressure: 2 to 32 oz./sq. in. in 0.5 oz./sq. in. / 8.6 mbar to 138.0 mbar in 2.2 mbar increments
- Carbon steel, 304 Stainless steel, 316 Stainless steel
- Optional Remote Monitoring
- EN 13463-1 and EN 13463-5 Certified

Emergency Relief Vent Enardo 2100



- Size: 16, 20, 24 in. / 400, 500, 600 mm
- Pressure: 0.7 to 8.0 oz./sq. in. in 0.5 oz./sq. in. increments / 3.0 mbar to 34.0 mbar in 2.2 mbar increments
- Aluminum/Carbon steel, 304 Stainless steel, 316 Stainless steel

Emergency Relief Vent Enardo 2500

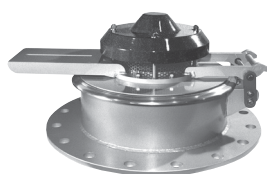

- Size: 16, 20, 24 in. / 400, 500, 600 mm
- Pressure: 4 to 16 oz./sq. in. in 0.5 oz./sq. in. increments / 17.2 mbar to 69.0 mbar in 2.2 mbar increments
- Vacuum: 0.5, 0.75, 1.0, 2.0 oz./sq. in. / 2.2, 3.2, 4.3, 8.6 mbar
- Carbon steel, 304 Stainless steel, 316 Stainless steel
- EN 13463-1 and EN 13463-5 Certified

Free Vent Enardo 4000, Enardo 4100



- Size: 2, 3, 4, 6, 8, 10, 12 in. / 50, 80, 100, 150, 200, 250, 300 mm
- Aluminum, Carbon steel, 304 Stainless steel, 316 Stainless steel

Rim Vent



- Size: 6 in. / 150 mm
- Pressure: 0.5, 1, 2, 4, 8 and 12 oz./sq. in. / 2.2, 4.3, 8.6, 17.2, 34.5, 51.7 mbar
- Aluminum
- EN 13463-1 and EN 13463-5 Certified

Features and Benefits

Time Proven Performance

- Economical production storage tank applications

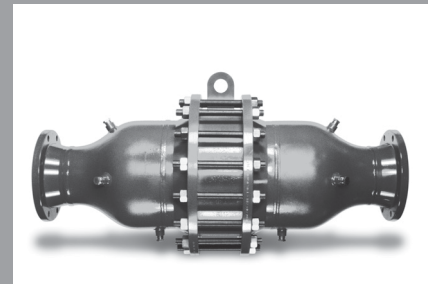

Emergency Relief

- Provides emergency venting relief per API 2000. Used in conjunction with pressure vacuum relief valves
- Provides superior relieving capacity for emergency conditions
- Increased level of tank safety in emergency conditions
- Highest relief settings available

Non Pressure Relief

- High capacity flow for non-flammable or non-volatile storage tanks
- Prevents foreign matter from entering tank

Gauge and Thief Hatches

Enardo™ A and Enardo A-L Hatches

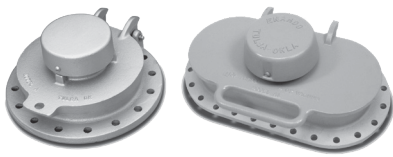

- Nominal 8 in. / 200 mm API Bolt pattern (Model Enardo A)
- Nominal 8 x 18 in. / 200 x 450 mm API Bolt pattern (Model Enardo A-L)
- Pressure: 2, 4 and 6 oz/sq. in. / 8.6, 17.2 and 26.0 mbar
- Vacuum: 0.4 oz/sq. in. / 1.7 mbar
- Aluminum, ductile iron

Enardo 200 Hatch



- Nominal 8 x 22 in. / 200 x 550 mm API Bolt pattern (Model Enardo A-L)
- Pressure: 1, 2, 3, 4 and 6 oz. / 4.3, 8.6, 12.9, 17.2 and 26.0 mbar
- Vacuum: 0.4 oz. / 1.7 mbar
- Aluminum, ductile iron

Enardo 660, Enardo 660B, Enardo 660-L, Enardo 660-LB

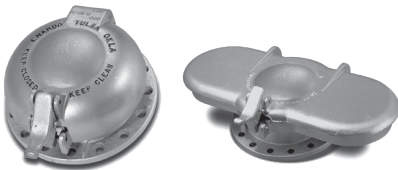

- Nominal 8 in. / 200 mm API Bolt pattern
- Pressure: 2, 4, 6, 8, 12, 16, 24 and 32 oz. / 8.6, 17.2, 26.0, 34.4, 52.0, 69.0, 103.0 and 138.0 mbar
- Vacuum: 0.4, 0.9 and 3.5 oz. / 1.7, 3.9 and 15.0 mbar
- Aluminum

Enardo ES-660, Enardo ES-660-B, Enardo ES-660-L, Enardo ES-660-LB, ES-660-HF



- Nominal 8 in. / 200 mm API Bolt pattern
- Pressure: 4, 6, 8, 12, 16, 24⁽¹⁾ and 32⁽¹⁾ oz. / 17.2, 26.0, 34.4, 52.0, 69.0, 103.0⁽¹⁾ and 138.0⁽¹⁾ mbar
- Vacuum: 0.4, 0.9 and 3.5 oz. / 1.7, 3.9 and 15.0 mbar
- Aluminum

1. Not available on Model Enardo ES-660-HF

Enardo ES-665



- Nominal 8 in. / 200 mm API Bolt pattern
- Pressure: 4, 6, 8, 12, 16, 24 and 32 oz. / 17.2, 26.0, 34.4, 52.0, 69.0, 103.0 and 138.0 mbar
- Vacuum: 0.4, 0.9 and 3.5 oz. / 1.7, 3.9 and 15.0 mbar
- Aluminum

Enardo 1000 Lock Down Hatch

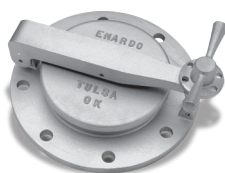

- API/ANSI Bolt pattern size: 8 in. / 200 mm
- ANSI Bolt pattern size: 8 in. / 200 mm
- Aluminum, carbon steel, stainless steel

Features and Benefits

Economical Dead Weight Hatches

- Large volume tank venting at low pressure
- Access for tank gauging
- Field replaceable gaskets
- “Sour gas” models available



Economical Spring Loaded Tank Hatch

- Multiple relief settings
- “Sour gas” models available

High Performance

- Tank hatch minimizes product losses. Envelope gasket provides superior sealing quality over conventional flat gaskets. Leakage rate of 1.0 SCFH at 90% set pressure.
- “Sour gas” models available

Highest Performance

- 0.10 SCFH at 90% of set pressure
- Minimizes emissions and product losses

Tank Access for Inspection and Gauging

- Vapor tight seal prevents leakage and evaporation losses
- “Sour gas” models available

Tank Blanketing and Vapor Recovery Regulators

Tank Blanketing Regulator Fisher™ Type T205 Series

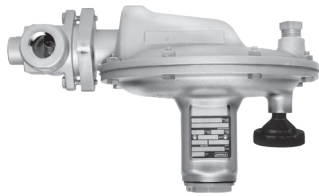

- **Body Size:** NPS 3/4 and 1 / DN 20 and 25
- **Control Pressure Range:** 1 in. w.c. to 7 psig / 2.5 mbar to 0.48 bar
- **Maximum Inlet Pressure:** 200 psig / 13.8 bar
- **Flow up to:** 24,765 SCFH / 663 Nm³/h of Nitrogen
- **Operation Method:** Direct-Operated
- **Body Material:** Cast iron, steel and stainless steel
- **Bulletin No.:** 74.1:T205
- **Compact size** is ideal for blanketing small tanks and vessels

Features and Benefits

Ideal for Blanketing Small Tanks and Vessels

- Compact size
- Easy to install and maintain

Tank Blanketing Regulator Fisher Type T205B



- **Body Size:** NPS 3/4 and 1 / DN 20 and 25
- **Control Pressure Range:** 1 in. w.c. to 7 psig / 2.5 mbar to 0.48 bar
- **Maximum Inlet Pressure:** 200 psig / 13.8 bar
- **Flow up to:** 19,388 SCFH / 519 Nm³/h of Nitrogen
- **Operation Method:** Direct-Operated
- **Body Material:** Cast iron, steel and stainless steel
- **Bulletin No.:** 74.1:T205B

Balanced Blanketing Regulator

- Fully balanced design
- Reduces inlet pressure sensitivity
- Accurately controls tank pressure at low pressure settings on tank blanketing systems

Tank Blanketing Regulator Fisher Type Y692



- **Body Size:** NPS 1-1/2 and 2 / DN 40 and 50
- **Control Pressure Range:** 1 in. w.c. to 10 psig / 2 mbar to 0.69 bar
- **Maximum Inlet Pressure:** 150 psig / 10.3 bar
- **Flow up to:** 19,820 SCFH / 531 Nm³/h of Nitrogen
- **Operation Method:** Direct-Operated
- **Body Material:** Cast iron, WCC steel and stainless steel
- **Bulletin No.:** 74.1:Y692

Accurate Pressure Control for Very Low-Pressure Blanketing Systems

- Provides quick response with downstream pressure sensed directly by the diaphragm
- Precise control even at low-pressure settings
- Pitot tube creates a dynamic boost that helps provide greater capacity

Tank Blanketing Regulator Fisher Type Y693

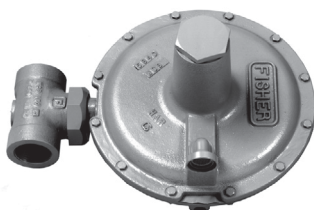

- **Body Size:** NPS 1-1/2 and 2 / DN 40 and 50
- **Control Pressure Range:** 0.5 in. w.c. to 10 psig / 1 mbar to 0.69 bar
- **Maximum Inlet Pressure:** 150 psig / 10.3 bar
- **Flow up to:** 26,700 SCFH / 716 Nm³/h of Nitrogen
- **Operation Method:** Direct-Operated
- **Body Material:** Cast iron, steel and stainless steel
- **Bulletin No.:** 74.1:Y693

The Accuracy of a Pilot-Operated Regulator in a Direct-Operated Design

- Balanced trim design and large diaphragm area provide high accuracy
- Minimal hysteresis
- Low inlet pressure sensitivity

Tank Blanketing and Vapor Recovery Regulators

Tank Blanketing Regulator Fisher™ ACE95 Series

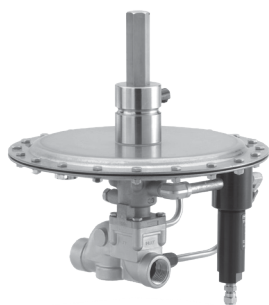

- **Body Size:** NPS 3/4, 1, 1 x 2 and 2 / DN 20, 25, 25 x 50 and 50
- **Control Pressure Range:** -5 in. w.c. to 1.5 psig / -12 mbar to 0.10 bar
- **Maximum Inlet Pressure:** 200 psig / 13.8 bar
- **Body Orientation:** In-line or Angle
- **Flow up to:** 499,600 SCFH / 13,390 Nm³/h of Nitrogen
- **Operation Method:** Pilot-Operated
- **Body Material:** Stainless steel
- **Bulletin No.:** 74.1:ACE95

Tank Blanketing Regulator Fisher Type 1190



- **Body Size:** NPS 1, 2, 3, 4, 6, 8 x 6 and 12 x 6 / DN 25, 50, 80, 100, 150, 200 x 150 and 300 x 150
- **Control Pressure Range:** 0.25 in. w.c. to 7 psig / 0.6 mbar to 0.48 bar
- **Maximum Inlet Pressure:** 400 psig / 27.6 bar
- **Flow up to:** 2,811,000 SCFH / 75,335 Nm³/h of Nitrogen
- **Operation Method:** Pilot-Operated
- **Body Material:** Cast iron, steel and stainless steel
- **Bulletin No.:** 74.1:1190

Vapor Recovery Valve Fisher T208 Series



- **Body Size:** NPS 3/4 and 1 / DN 20 and 25
- **Control Pressure Range:** 2 in. w.c. to 7 psig / 5 mbar to 0.48 bar
- **Maximum Inlet Pressure:** 75 psig / 5.2 bar
- **Flow up to:** 2320 SCFH / 62.2 Nm³/h of Nitrogen
- **Operation Method:** Direct-Operated
- **Body Material:** Cast iron, steel and stainless steel
- **Bulletin No.:** 74.2:T208

Vapor Recovery Valve Fisher Type 1290



- **Body Size:** NPS 1, 2, 3, 4, 6, 8 x 6 and 12 x 6 / DN 25, 50, 80, 100, 150, 200 x 150 and 300 x 150
- **Control Pressure Range:** 0.5 in. w.c. to 7 psig / 1 mbar to 0.48 bar
- **Maximum Inlet Pressure:** 12.5 psig / 0.86 bar
- **Flow up to:** 327,400 SCFH / 8774 Nm³/h of Nitrogen
- **Operation Method:** Pilot-Operated
- **Body Material:** Steel and stainless steel
- **Bulletin No.:** 74.2:1290

Features and Benefits

Accurate Pressure Control on Low-Pressure Systems

- Oversized actuator offers high sensitivity to changes in tank pressure
- High accuracy to pressure control
- Single pilot design minimizes issues with overlapping setpoints

Very Accurate Pressure Control on Low-Pressure Systems

- High-capacity
- Very accurate
- Top-entry design reduces maintenance time and manpower requirements
- Not affected by changes in the pressure recovery system

Ideal for Small Vapor Recovery Systems

- Designed for use as a backpressure or relief valve

High-Capacity and Highly Accurate

- High-capacity
- Very accurate
- Opens when tank pressure increases above desired setpoint
- Not affected by changes in the pressure recovery system

NOTES:

Flame and Detonation Arrestors

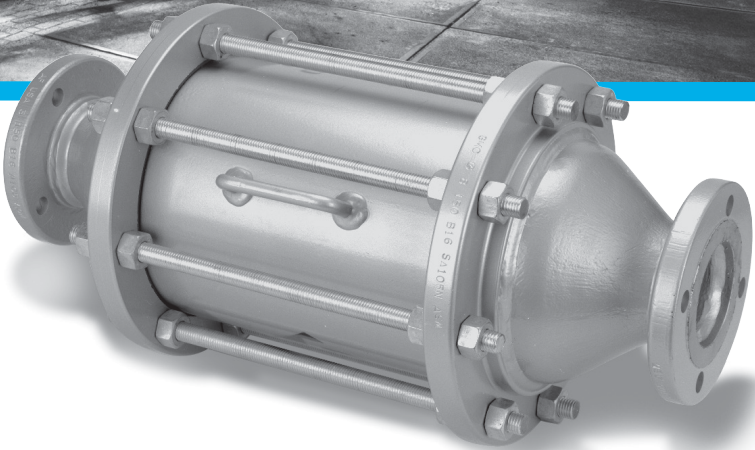

Flame Arrestor Technology



A Flame Arrestor is a device which allows gas to pass through it but stops a flame in order to prevent a larger fire or explosion. There is an enormous variety of situations in which flame arrestors are applied. Anyone involved in selecting flame arrestors needs to understand how these products work and their performance limitations. For that purpose, this paper provides an introduction to the technology and terminology of flame arrestors and the types of products available.

Blocking Flame With Narrow Passages

The operating principle of flame arrestors was discovered in 1815 by Sir Humphry Davy, a famous chemist and professor at the Royal Institution in England. A safety committee of the English coal mining industry had approached Davy for technical assistance. They needed a way to prevent miners' oil lamps from causing explosions when flammable gas called firedamp seeped into the mine shafts. Sir Humphry studied the gas, which consisted mostly of methane. The investigation centered on how methane burns under various conditions and with various proportions of air. Davy's solution was to enclose the lamp flame securely with a tall cylinder of finely woven wire screen called metal gauze. Three of the earliest Davy safety lamps are shown in Figure 1.

Enough lamplight passes out through the screen to be useful. Air for the oil flame around the lamp wick enters through the



Figure 1. The earliest flame arrestors: Davy safety lamps for coal miners.

lower part of the screen. Hot exhaust gas escapes through the upper part. When a combustible mixture of methane flows in with the air, a methane flame burns against the inside of the screen. However, neither the methane flame nor the lamp flame passes through the narrow openings of the screen. The metal wire absorbs heat from the flame and then radiates it away at a much lower temperature.

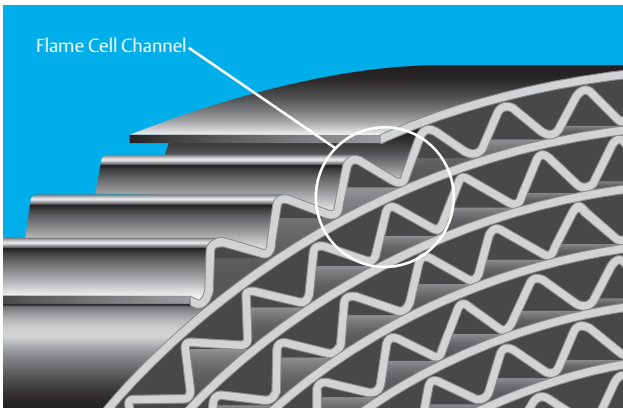

Figure 2. Concept of flame arrester element, featuring a crimped wound metal ribbon element

Modern Flame Arrestors

Since Sir Humphry's time, flame arrestors of numerous varieties have been applied in many industries. All of them operate on the same principle: removing heat from the flame as it attempts to travel through narrow passages with walls of metal or other heat-conductive material. For instance, flame arrestors designed and manufactured by Emerson employ layers of metal ribbons with crimped corrugations as shown in Figure 2.

Flame arrestors are used in approximately 22 industries, including refining, pharmaceutical, chemical, petrochemical, pulp and paper, oil exploration and production, sewage treatment, landfills, mining, power generation and bulk liquids transportation. In some cases, the flames involve exothermic (heat-producing) reactions other than oxidation. Processes which generate the combustible or reactive gases include blending, reacting, separation, mixing, drilling and digesting. These processes involve numerous equipment configurations and gas mixtures.

End-of-Line, Vent-to-Atmosphere Type



Most flame arrester applications and designs fall into two major categories. One group consists of end-of-line flame arrestors, also known as the vent-to-atmosphere type (Figure 3).

Figure 3. End-of-line flame arrestors are used in applications such as petroleum storage tank vents.

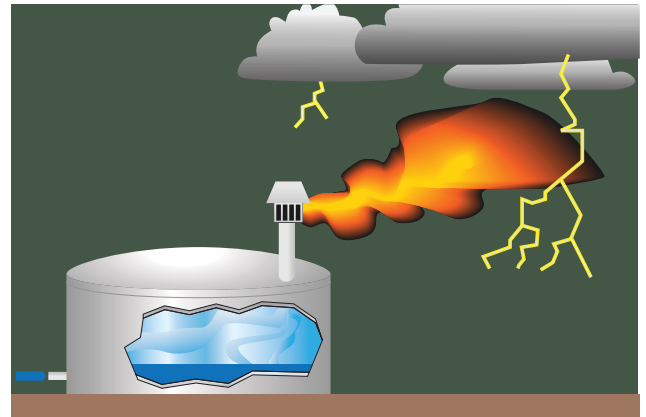

Figure 4. Oilfield storage tank vents were an early application of industrial flame arrestors.

The classic application is in preventing fire in the atmosphere from entering an enclosure. Around 1920, for instance, flame arrestors began to be installed on vents on oilfield storage tanks. They keep the tanks from exploding when gas flowing from the vents is struck by lightning (Figure 4).

Conversely, some end-of-line flame arrestors prevent fire in an enclosure from igniting an explosive atmosphere such as in a refinery. For instance, flame arrestors may be installed in furnace air inlets and exhaust stacks. The Davy lamp might be considered another example of that sort.

In-Line, Deflagration or Detonation Type

The other major category consists of in-line flame arrestors, also known as deflagration and detonation flame arrestors. (Speaking non-technically, deflagration means rapid burning and detonation means explosion.) These units are installed in pipes to prevent flames from passing, as shown in Figure 5.

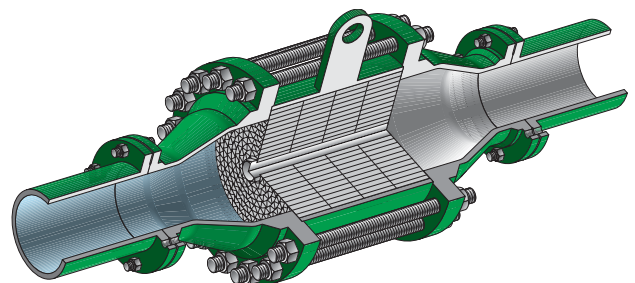

Figure 5. A typical In-line Flame Arrester.

Flame Arrestor Technology

Most in-line flame arrestor applications are in systems which collect gases emitted by liquids and solids. These systems, commonly used in many industries, may be called vapor control systems. The gases which are vented to atmosphere or controlled via vapor control systems are typically flammable. If the conditions are such that ignition occurs, a flame inside or outside of the system could result, with the potential to do catastrophic damage.

One variety of vapor control systems is called vapor destruction systems. Included are elevated flare systems (Figure 6), enclosed flare systems, burner and catalytic incineration systems and waste gas boilers.

Another type of vapor control system using in-line flame arrestors is vapor recovery systems. Included here are vapor balancing, refrigeration, adsorption, absorption and compression systems.

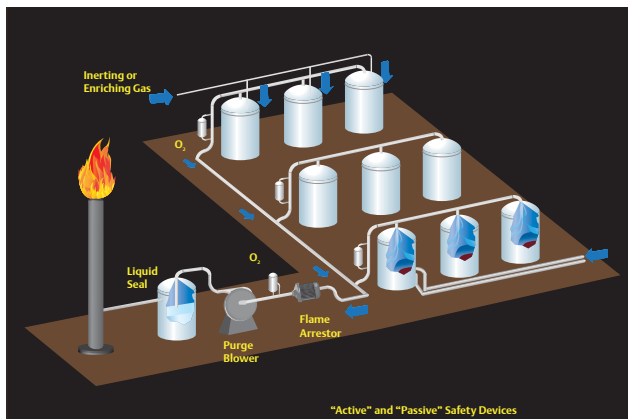
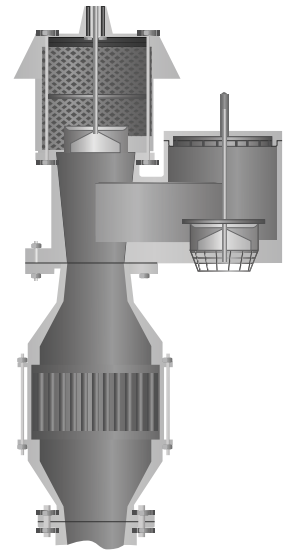

Figure 6. An in-line flame arrestor in a flare system.

However, in-line flame arrestors are sometimes used in end-of-line applications. For instance, an in-line unit may be mounted below a tank vent valve on a liquid storage tank (Figure 7). The valve reduces emissions and product loss, while the flame arrestor protects the tank from flames in the atmosphere during venting of flammable gases.

As technology throughout the world has become more complicated, safety products have also evolved to meet new requirements. Flame arrestors, in particular, changed immensely during the last decade of the twentieth century. As will be explained later, flames in pipes can reach much

Figure 7. An in-line flame arrestor used in an end-of-line application (below a pressure and vacuum relief valve for a liquid storage tank).



higher speeds and pressures than in the open atmosphere. Therefore in-line flame arrestors are now subdivided into three categories on that basis. Furthermore, special provisions are made for each of the three major groups of gases according to degree of flame hazard (also explained later)—NEC Groups B, C and D. Thus, there are now as many as twelve different types of flame arrestors, as follows:

1. End-of-line, Group B
2. End-of-line, Group C
3. End-of-line, Group D
4. In-line, low/medium-press. deflagration, Group B
5. In-line, low/medium-press. deflagration, Group C
6. In-line, low/medium-press. deflagration, Group D
7. In-line, high-pressure deflagration, Group B
8. In-line, high-pressure deflagration, Group C
9. In-line, high-pressure deflagration, Group D
10. In-line, detonation, Group B
11. In-line, detonation, Group C
12. In-line, detonation, Group D

In applying flame arrestors, it should be remembered that these safety devices are passive ones and they are often used together with active safety devices. Active devices used in flame safety include hydraulic (liquid) seals, isolation valves, blankets of inert gas or enriching (fuel) gas, gas analyzers and oxygen analyzers. Unlike active devices, passive devices such as flame arrestors do not depend on a power source, have no moving parts and do not require human attention except to be cleaned periodically.

For example, the primary flame safety devices in a vapor control system are usually active ones such as liquid seals and oxygen analyzers as shown before in Figure 6. However, active devices can be rendered ineffective by loss of power, failure of mechanical components, failure of electronic communication or human error. Flame arrestors, in turn, are the system's secondary or fail-safe provision. In other words, if the active, primary method malfunctions, the passive, secondary method will be the last defense against an explosion.

Flame Propagation

The differences between the various types of flame arrestors are based mainly on the nature of the flame which is expected (especially how fast it moves) and on the expected intensity of the pressure pulse created by the flame. A flame is a volume of gas in which a self-sustaining exothermic (heat-producing) chemical reaction is occurring. The reaction is presumed to be oxidation, also known as combustion.

To have a flame, three things must be present; oxygen (supplied by air), very high temperature (initially supplied by an ignition source) and a flammable gas mixed with the air in suitable proportions called a combustible mixture. So long as these requirements remain available, a flame can burn indefinitely. Flame arrestors operate by removing one of these requirements: high temperature.

In a stationary flammable mixture, a flame seems to move toward the unburned gas, leaving combustion products behind. That apparent motion is called flame propagation. The flame exists only within a relatively narrow volume at the boundary between the unburned gas and the combustion products.

The speed at which the flame propagates is measured at the front edge of the flame. This speed depends on several variables, including the speed of the chemical reaction, the air-to-gas mixture ratio and whether the flame is confined or unconfined.

Chemical Reaction Kinetics

The speed of a chemical reaction, such as that between fuel gas and oxygen, is called its kinetics. This is determined mainly by the amount of energy released by each molecule of

flammable gas when it combines with oxygen. For instance, hydrogen burns much faster than propane. Thus, given ideal air mixtures at room conditions, an open (unconfined) hydrogen flame propagates at 3 meters per second, compared to only 0.4 meters per second for propane. However, reaction speed also depends strongly on the temperature and pressure: the hotter a flame and the higher its pressure, the faster the reaction that sustains it.

Air-to-Gas Mixture Ratio

Another determinant of flame propagation speed and pressure generation is the air-to-gas mixture ratio. A given flammable gas will sustain a flame only within a certain mixture range at a given pressure and temperature.

If there is too little gas for a lasting flame at that condition, the mixture is said to be too "lean" to burn. In that case, the concentration (volumetric percentage) of gas in the air is below the lower explosion limit (LEL) for that particular gas. This is the concentration below which a flame will not last at that pressure and temperature. For example, the LEL at room conditions is 2.1% for propane and 4.0% for hydrogen.

Conversely, if there is too little air, the mixture is too "rich" to burn. The upper explosion limit (UEL) for a particular gas is the concentration of gas above which a flame will die out at a given pressure and temperature. At room conditions, propane's UEL is 9.5% and hydrogen's is 75.0%.

The flammable range of a gas is the difference between its lower and upper explosion limits. Hydrogen has a much wider flammable range than propane.

A mixture with exactly the right amount of oxygen for complete combustion—no more, no less, producing the maximum energy per volume of gas—is called stoichiometric. Air-to-gas ratios at or near stoichiometric provide the highest flame propagation velocities and thus the most intense pressure impulse waves. However, as long as the mixture is well within the flammable range, the flame velocity ordinarily does not vary a great deal.

Flame Arrestor Technology

Unconfined Propagation of Flame

Flames generally propagate much faster in pipes than in the open atmosphere. Flames which are not restricted by physical barriers such as pipes are called unconfined. An unconfined flame is free to expand by consumption of unburned gas into an ever-widening volume. This expansion provides quick dissipation of the heat and pressure energy generated by the flame.

The most common example of unconfined propagation occurs when gas venting from a process system or liquid storage tank contacts an ignition source (Figure 8). From that point, flame propagates outward and towards the unburned gas until it comes to the gas source.

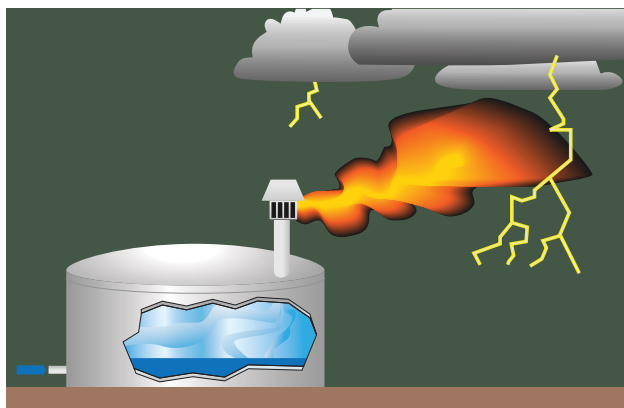

Figure 8. Concept of an unconfined deflagration

When the unconfined flame first begins to consume the unburned gas, the flame front travels below sonic velocity (the speed of sound in the atmosphere). If the velocity remains subsonic, the event is called a deflagration; the gas is said to deflagrate, meaning burn rapidly. By contrast, flame propagation at or above the speed of sound is called a detonation, which is an explosion strong enough to cause shock waves in the gas. Some gases can detonate without being confined, but it is not a common occurrence.

As the subsonic flame moves in the direction of the unburned gas, it produces heat. The heat, in turn, expands the unburned gas in a layer in front of the flame, called the boundary layer. The rapid expansion of the boundary layer along with the fast-moving flame is commonly called an

atmospheric explosion and percussion wave. The pulse of elevated temperature and pressure quickly spreads out and dissipates into the atmosphere in a relatively simple manner.

Confined Propagation of Flame

The most common example of confined flame is propagation inside a pipe or explosion inside a process vessel or liquid storage tank. The flame is usually a flashback, meaning that it propagates upstream, against the flow of gas and towards its source. The heat and pressure energy of a confined flame is not relieved as readily as that of an unconfined flame. This restriction of energy dissipation makes a tremendous difference in how the flame propagates and thus what kind of flame arrestor is required to stop it.

In a readily combustible mixture, the velocity of an unconfined flame depends primarily on the kinetics of the combustion reaction. Most of the combustion heat and resulting pressure are dissipated in the surrounding atmosphere, without influencing propagation speed very much.

Confined flames also rely on the kinetics of burning for flame propagation velocity. However, since the flame is confined, the heat energy and pressure remain concentrated, causing a much stronger effect on the kinetics of burning and therefore the flame propagation velocity.

More particularly, imagine a very long, straight pipe about six inches in diameter, closed by a cap at one end and filled with combustible mixture at room temperature and pressure. Suppose the gas is ignited by a spark plug at the closed end as suggested in Figure 9. A flame propagates in the unburned gas along the pipe. As described before for an unconfined flame, the heat of the flame expands the gas boundary layer directly in front, causing a pulse of pressure. However, the energy is not allowed to dissipate by spreading into an ever-widening region of atmosphere. Instead, as

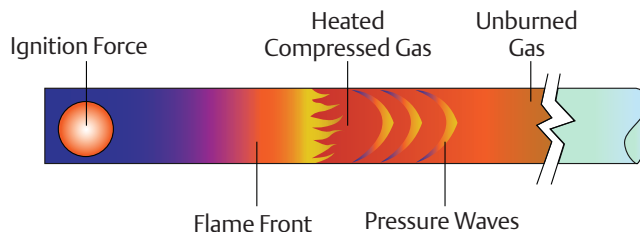

Figure 9. Elements of flame propagation from the closed end of a pipe of indefinite length.

the flame propagates down the pipe, it encounters gas with higher temperature and pressure, speeding the combustion reaction. This process feeds on itself, producing flame velocities, temperatures and pressures much higher than those seen in unconfined conditions.

To be more precise, suppose a pressure gauge capable of extremely quick response is placed 10 meters away from the ignited end. As the flame moves towards the gage, the reading increases. When the flame reaches the gage, it causes a pressure spike as high as 100 psig / 7 bar or higher.

While propagating down a pipe, the flame functions not only as a chemical reaction, but also as a mechanical reaction—like a piston in a cylinder—compressing the gas before consuming it and im-parting more energy and velocity. If the pipe is long enough, in some cases the flame can reach hyper-sonic (much faster than sound) velocities as high as 6500 miles per hour / 2900 meters per second. The pressure may approach 4900 psig / 34,000 kPa.

Development Stages of Confined Flame

Selection of an appropriate in-line flame arrestor depends on how intense any flame in the pipe is expected to be, in terms of velocity and pressure. Studies of flame propagation in pipes reveal seven distinct stages or phases which a flame may reach if the pipe is long enough and the combustion is fast enough and energetic enough.

These stages are illustrated in Figure 10 by imaginary graphs of the speed and pressure of a flame at each point as it travels along a pipe of indefinite length. Note that the pressure is the transient peak that would be indicated by a very quick-response gauge at each point along the pipe. The flame reaches stages labeled A through F, one after another, at increasing distances from the ignition point.

Low-Pressure Deflagration

So long as the flame front travels well below the speed of sound with minimal pressure increase caused by the expanding boundary layer, its condition is considered to be low-pressure deflagration (Figure 11). That stage is generally associated with velocities up to about 112 meters per second

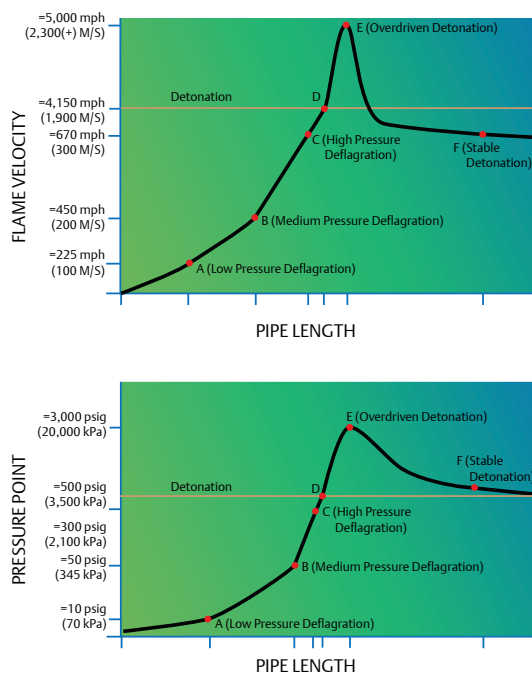

Figure 10. Conceptual graphs showing flame velocity and pressure of a flame front at points along a long pipe, beginning with ignition at a closed end. All scales are logarithmic.

and relative increases of absolute pressure (DP/P_0) up to 1. (Assuming initial atmospheric pressure, the gauge pressure is less than about 100 kPa(g)). This initial flame propagation state develops in a short length of pipe—for example, approximately 3 meters for a propane-air mixture. Hydrogen is in its low-pressure deflagration state only to about 1.0 meter from the point of ignition.

(DP/P_0 is the dimensionless ratio for deflagration and detonation testing as measured in the piping system on the side of the arrestor where ignition begins. P_0 is the system initial absolute pressure. DP is the measured absolute pressure, minus P_0 .)

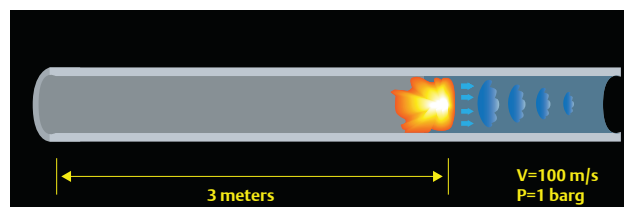

Figure 11. Concept of low-pressure deflagration confined in a pipe, showing typical distance from ignition point.

Flame Arrestor Technology

Medium-Pressure Deflagration

As the flame propagates farther down the pipe, its intensity increases to the dynamic state of medium-pressure deflagration. Flame speed is higher but still subsonic—up to 200 m/s. The pressure impulse at the flame reaches levels considered to be medium, with DP/P_0 up to 10. For a propane/air mixture beginning at room conditions, the flame is in this state when passing from about 3 to about 10 meters from the ignition point. Hydrogen, by comparison, is in its medium pressure deflagration state between 1.0 and 2.5 meters from ignition (Figure 12).

High-Pressure Deflagration

Beyond the limit of medium-pressure deflagration, the propagating flame reaches the condition of high-pressure deflagration. The flame front velocity—still subsonic—is up to 300 m/s and the pressure increase caused by the expanding boundary layer reaches a DP/DP_0 as high as 20. The distance from the ignition point is between 20 and 30 meters for a propane/air mixture and between 2.5 and 6 meters for hydrogen and air (Figure 13).

Deflagration-to-Detonation Transformation

When the propagating flame front passes sonic velocity, what occurs is called transformation from deflagration to detonation, abbreviated DDT. The pressure impulse in front of the flame becomes a shock wave. The compressed gas immediately in front of the expanding boundary layer of gas just in front of the flame, which can reach pressures around 700 kPa(g), comes in contact with the flame. The result is an explosion. The energy of that explosion, which includes heat, velocity and pressure, has nowhere to go but down the pipe. The explosion generates tremendous shock-wave compression of the gases both upstream and downstream of the initial point of transformation (Figure 14).

Detonation

A detonation is defined as a flame front moving at or above the speed of sound. It entails increased compression of the gases by shock waves in front of the flame. A detonation may have a velocity in the range of 300 m/s and a maximum impulse pressure of 3500 kPa(g), with DP/P_0 as high as 20. This flame propagation state develops in a pipe length

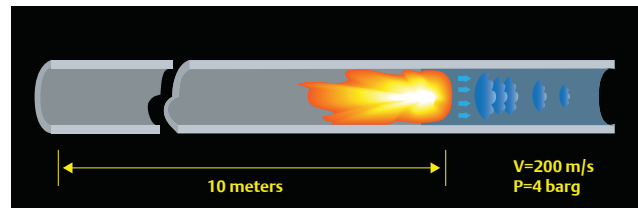

Figure 12. Concept of medium-pressure deflagration confined in a pipe, showing typical distance from ignition point.

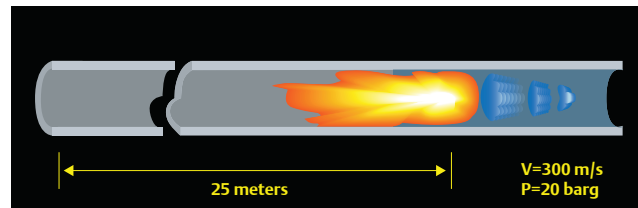

Figure 13. Concept of high-pressure deflagration confined in a pipe, showing typical distance from ignition point.

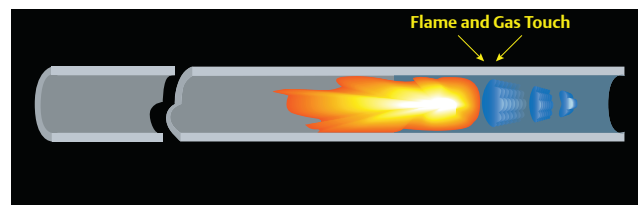

Figure 14. Concept of deflagration-to-detonation transformation in a pipe.

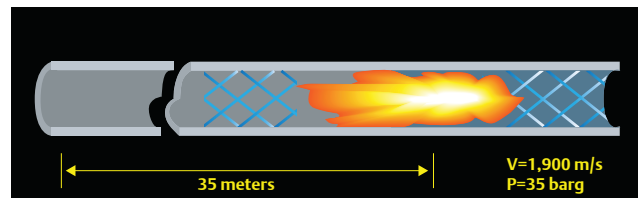

Figure 15. Concept of detonation confined in a pipe, showing typical distance from ignition point.

from slightly beyond the high-pressure deflagration up to approximately 30 meters beyond the ignition point for a propane/air mixture and approximately 10 meters for hydrogen in air (Figure 15).

Overdriven (Unstable) Detonation

As the flame propagates even farther down the pipe, it goes into the dynamic state of overdriven or unstable detonation. This is defined as a flame front moving at supersonic velocity and in some instances at hypersonic velocity, attended by tremendous compression of gas by multiple shock waves. It is an unstable and transient condition. As the flame goes through DDT, it continues to pile shock waves into a dense concentration. Gas in front of the flame is compressed and

heated above the ignition point like the fuel mixture in a diesel engine cylinder. When the compressed gas self ignites, the explosion releases an extremely large amount of energy, much like the earlier DDT. Again, the energy is restrained by the piping and only allowed to move straight ahead. Since the flame velocity is already supersonic, the flame accelerates to hypersonic velocities (Figure 16).

The reason this condition is temporary is that the flame velocity and pressure are dependent on numerous shock waves providing gas compression in front of the flame. These shock waves dissipate soon after the initial explosion and the velocity and pressure of the flame stabilize. An overdriven detonation has a typical peak velocity in the range of 2300 m/s and a maximum impulse pressure of about 20,995 kPa(g)—equivalent to a DP/P_o of 130. This flame propagation state develops in a pipe length beginning just beyond the DDT and ending approximately 60 meters from the ignition source for a propane/air mixture and 20 meters for hydrogen and air.

Stable Detonation

Beyond the transient overdriven detonation, the propagating flame finally reaches the dynamic state of stable detonation. The flame front moves at or above the speed of sound with shock-wave compression in front. The flame will not go through any more transitions but will remain in this stable condition to the other end of the pipe. A stable detonation has a velocity in the range of 300 m/s and a peak impulse pressure of 3,500 kPa(g), equivalent to a DP/P_o of 20 (Figure 17).

Galloping Detonation

A detonation that periodically fails and reinitiates during propagation is known as a galloping detonation. *“This type of detonation is typically observed in near-limit mixtures (they have been observed near the lean and possibly near the rich limit). Since it reinitiates via DDT, a galloping detonation is periodically overdriven and results in large overpressures at periodic distances along a pipe. Over these periodic cycles the wave oscillates between a fast deflagration and a leading shock, transition to an overdriven detonation and a short lived apparently steady detonation phase.”*¹

1. Grossel, Stanley, Deflagration and Detonation Flame Arresters (AIChE, 2002), 66.

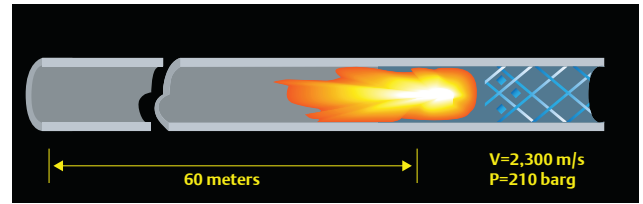

Figure 16. Concept of overdriven detonation confined in a pipe, showing typical distance from ignition point.

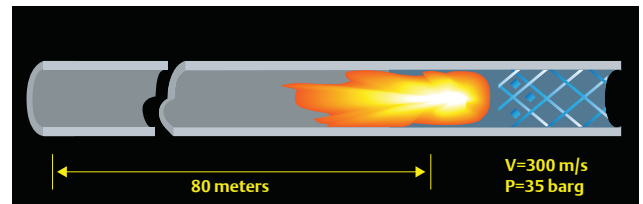

Figure 17. Concept of stable detonation confined in a pipe, showing typical distance from ignition point.

Selection Considerations for In-Line Flame Arrestors

Selecting an appropriate in-line flame arrestor for a given application requires understanding several considerations. These considerations are based on the foregoing general understanding of how an accidental gas flame behaves in pipes.

Burn-Back Gas Velocity

When a flammable mixture is flowing in a pipe, one especially important condition is the burn-back gas velocity. It is the gas velocity at which a flame is stationary when propagating upstream in a condition of low-pressure deflagration. This refers to the “superficial” average gas velocity across the pipe—the volumetric flow rate divided by the cross-sectional flow area. If the gas flows slower than the burn-back velocity, a flame can propagate upstream. The burn-back velocity depends on the type of gas and its air-to-gas mixture ratio as well as the temperature and pressure. At stoichiometric mixture and standard room conditions, propane’s burn-back velocity is approximately 3.2 m/s, whereas hydrogen’s is approximately 20 m/s.

If the gas feeding a flare or waste gas burner slows down below the burn-back velocity at the flare tip or burner, then the flame moves upstream toward the process source. If the gas velocity is only slightly lower than the burn-back velocity,

Flame Arrestor Technology

the flame will creep slowly upstream. However, at zero gas velocity in a long pipe, the flame will accelerate as explained before and flash back at high speed. Zero flow allows the most severe flame propagation conditions. All flame arrestor products should be tested by the manufacturer at static (zero) flow so that they will work in the most severe flame propagation conditions (flashback).

Initial Operating Pressure (IOP)

The initial operating pressure (IOP) is the absolute pressure of a flammable gas mixture in a given piping system when the velocity falls below the burn-back velocity. The IOP is usually less than the normal operating pressure of that system. For example, when a vapor control system is operating properly, so that the flow stream velocity is above the burn-back velocity of the process gas, then the system pressure is within some normal operating range above atmospheric pressure. But when the system is shut down during normal or emergency conditions and the process stream slows down, the pressure also falls. At some point before the velocity reaches zero, a flashback can occur. The pressure in the system in this shutdown situation or static flow condition is the IOP for that particular system.

Remember that pressure affects flame: the higher the pressure, the more energy the flame releases per unit volume. That equates to higher flame intensity and energy exchange per unit volume and faster flame acceleration. The explosive pressure of a given gas is roughly proportional to the initial absolute pressure. For instance, doubling the absolute pressure approximately doubles the explosive pressure.

Therefore, the IOP in a given system determines two things pertaining to selection of a flame arrestor product. The first is flame velocity and pressure relative to the distance the flame has traveled down the pipe. For example, when a flame has propagated 10 meters in a stoichiometric propane-to-air mixture at atmospheric pressure (101.3 kPa absolute), the flame velocity is approximately 200 m/s and the pressure front is at about 800 kPa absolute. If instead the IOP is increased to 150.0 kPa, the flame velocity and pressure at 10 meters will be approximately 300 m/s and 1200 kPa. Thus,



in this example, increasing the static pressure 50% causes an increase of 50% in the velocity of the flame front and 50% in its pressure. This consideration can affect how close to the ignition source the arrestor must be placed. It can also require the use of one arrestor device rather than another.

The second selection consideration affected by IOP pertains to the energy which an arrestor must absorb per unit volume of gas in order to quench a flame. When pressure increases in a process system, the energy released by flame per unit volume also increases. Thus the arrestor must absorb more heat to lower the flame's temperature sufficiently. However, that task can be difficult for the arrestor, since it was designed with a certain heat transfer capacity. If an arrestor is placed in an application for which the IOP is higher than it has been tested or designed for, the arrestor could fail to stop the flame. Therefore, to enable proper selection and system design, manufacturers must indicate the maximum IOP which their flame arrestors can handle for various flammable gas mixtures. Every flame arrestor product should be tested at a series of increasing pressures to determine its IOP performance threshold for commonly encountered gas mixtures. For example, a standard low-pressure deflagration arrestor typically has a maximum allowed IOP of around 5% above atmospheric condition or 106.0 kPa / 15.4 psia, while that for detonation flame arrestors ranges up to 160 kPa / 23 psia.

Transient Momentum Pressure

Piping can withstand a propagating flame driving a pressure pulse which may be thousands of times greater than the maximum pressure for which the pipe is rated. This pressure caused by flame propagation is not a static pressure, because the pressure wave is moving so fast it exerts its force on the piping walls for only a fraction of a second. Instead, flame pressure is considered a dynamic impulse pressure, called transient momentum pressure or TMP. Because the transient motion of gas in the forward direction is so rapid when a pressure wave passes, the wave carries a tremendous amount of momentum (mass multiplied by velocity) and resulting energy (one-half of mass multiplied by the square of velocity). Anything which changes the direction of that momentum, such as pipe bends, shut-off valves, blower housings or an arrestor device, experiences transfer of energy via momentum. This momentum energy can have a catastrophic effect on equipment.

Standard flame arrestors are designed for low transient momentum pressures (TMPs) and can fail mechanically when exposed to very high TMPs. Enardo™ DFA Series are designed to withstand TMPs of any magnitude.

Flame Stabilization

There are two types of flame stabilization: open and confined. An open stabilized flame occurs when a flammable mixture emerges from confinement at a velocity such that an open flame fed by the gas is stationary. For example, when a flare is burning, the stationary flame at the tip experiences open flame stabilization. If for some reason the process stream slows down below the burn-back velocity of the gas, the flame begins moving down the flare stack. It may then

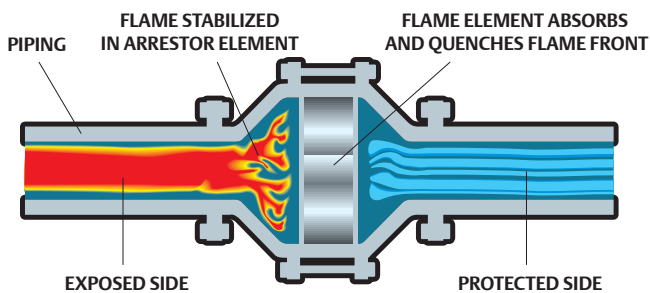

Figure 18. Concept of flame stabilization at a flame arrestor.
Flow is from right to left.

stabilize at the arrestor device or somewhere else down the pipe. This condition is referred to as confined flame stabilization (see Figure 18). If the process stream velocity were to go to zero, the flame would not creep down the flare but would accelerate in a flashback and possibly detonate. The possibility for a stabilized flame in the system during flashback is very slight, but it sometimes happens.

Each flame arrestor design performs differently when exposed to flame stabilization, depending on the mass and type of material of the flame-arrestor element. Users should contact the manufacturer of a given arrestor for information on how its products perform when exposed to flame stabilization. A good way to safeguard against flashback due to flame stabilization is to install a temperature sensing device on the exposed side of the arrestor. The heat of a stabilized flame triggers automatic controls designed to extinguish the flame.

Air-to-Fuel Mixture Ratios

The ratio of combustible gas to air, described earlier, has a profound effect on how a flame burns. It influences not only flame speed as mentioned before, but also heat intensity, ignition energy, auto-ignition temperature, pressure piling and others.

Grouping of Gases

Hundreds of different flammable gases are generated as products or by-products of industrial processes. One gas may vary widely from another in its characteristics pertaining to flame propagation. It is necessary to have means for describing those characteristics in order to design safety equipment, instrumentation, etc. Several testing and regulatory bodies, including the NEC, IEC, NFPA and NTIS, classify flammable gases based on the following criteria, some of which are explained later:

- MESG (maximum experimental safe gap)
- Flame temperature
- Flame velocity
- AIT (auto-ignition temperature)
- LEL-to-UEL range
- Ignition energy

Flame Arrestor Technology

Each testing or regulatory authority has its own system for classifying gases according to combustion hazard groups. Classifications are based on severity of explosion hazard as indicated by low AIT, broad LEL-to-UEL range, higher flame temperature, faster flame velocity or a combination of any of these characteristics. Most of them relate directly to the MESG of the combustible gas. (See Table 1.)

NEC	IEC	MESG	Test Gas List
Group A	----	0.25	Acetylene
Group B	Group IIC	0.28	Hydrogen
	Group IIB	0.50	Enriched H ₂
Group C	Group IIB3	0.65	Ethylene
Group D	Group IIA	0.90	Propane
G.M	----	1.15	Methane

Table 1. Hazardous gas groups according to NEC and IEC

Maximum Experimental Safe Gap (MESG)

Maximum experimental safe gap is a standard measurement of how easily a gas flame will pass through a narrow gap bordered by heat-absorbing metal. MESG was developed to classify gases for design and selection of electrical instrumentation, electrical enclosures and flame arrestor devices. The measurement is conducted with a standard apparatus consisting of a small, hollow metal sphere of a certain diameter which is split into two halves. The circular edge of each hemisphere is provided with a smooth metal flange of a certain width. The hemispheres are held close together in the apparatus with the flanges parallel and separated by a narrow gap. This apparatus is immersed in a stoichiometric mixture of the test gas and air at standard room conditions and the mixture inside the sphere is ignited with an electric spark. The experiment is repeated with a wider and wider gap between the two flanges, until the mixture outside the sphere is ignited. The MESG is the greatest distance between flanges at which the flame fails to pass through. The more hazardous the gas, the narrower the MESG. An arrestor must be designed for the MESG value of the process gas.

Multiple Gas Mixtures

Some vapor collection systems deal with a single, relatively pure combustible gas—for instance methane or acetylene—mixed with air. However, most processes requiring flame arrestors involve mixtures of several combustible gases,

each having its own set of hazard characteristics. Some gases consume air more efficiently than others in a mixture, thus making the mixture behave much like a single constituent gas. One gas component may act as a catalyst to another, making the mixture more dangerous than the single most hazardous gas by itself. Not much experimental data is available on the hazardous characteristics of combustible gas mixtures.

The MESG of mixed gases is not normally known and it is impractical to test all gas mixtures for their MESG. The industry standard has been to select an arrestor design based on the worst case gas component in the mixture. This method is in most cases, overly conservative. NFPA 497 provides a new method to estimate the group classification based on knowing the MESG of each flammable gas component and calculating the effective MESG by applying a form of Le Chatelier's relationship. Emerson can assist you with this calculation if provided the gas mixture composition.

Auto-Ignition Temperature (AIT)

AIT is the temperature at which a stoichiometric mixture of a combustible gas at standard atmospheric pressure will ignite. Propane's AIT is 493°C, Hydrogen's is 560°C and ethylene's is 425°C. An arrestor works by cooling the gas below its AIT. Therefore, if the process is operating close to the AIT of the gas, this initial heat may affect the performance of the arrestor. It is very important that the process temperature be stated to the manufacturer when selecting an arrestor.

Length to Diameter (L over D) Ratio

In explaining the various stages of flame propagation earlier, each stage was said to occur within a certain range of distances from the ignition source. Those distances were specified for a certain inside pipe diameter of 12 in. It turns out that the distances are directly proportional to the diameter. What matters is not the actual distance from the ignition point, but the distance relative to the diameter—the distance divided by the diameter. That relative distance is called the length-to-diameter ratio or the L/D ratio (L over D ratio). For example, for a stoichiometric air-propane mixture at room conditions, a low-pressure deflagration will occur within an L/D ratio less than 10 and a stable detonation will usually occur at L/D ratios greater than 60. All arrestors

except the unstable detonation types have L/D performance limitations. Information on these limitations must be obtained from the manufacturer.

Pipe Configuration and Restrictions

How a flame burns and propagates is affected not only by the length of a pipe, but also by bends, instrumentation (metering runs, restrictive orifices, thermowells, etc.), pipe contractions and expansions, valves, etc. Anything which increases turbulence of the gas gives the flame a more uniform air-to-gas mixture, thus enhancing combustion.

In addition, as mentioned before, transient momentum acts on piping irregularities. Gas expansion caused by burning acts as thrust propulsion when given a surface on which to apply the force of expansion. The flame cannot exert a thrust force on smooth, straight pipe. However, when it travels past a bend or restriction, it can exert a force on this surface area, giving it a forward velocity and pressure boost.

Each arrestor design has been tested to protocols which may or may not include bends and restrictions. The manufacturer should be consulted before installing any arrestor in a system with bends or restrictions.

Ignition Source and Energy

Accidental gas ignition can be caused by such things as static discharge, sparks from a blower impeller hitting the blower housing, instrumentation, pilot flame for a flare or burner, main flame on the flare tip or in the burner chamber, hot work within a plant, external fire and many other origins. These ignition sources can cause a flame inside or outside a process system.

The ignition energy is defined as the amount of energy required to ignite a flammable gas mixture. That amount depends on the type of gas and the air-to-gas mixture ratio. The closer the air-to-gas ratio is to stoichiometric, the lower the ignition energy. This is illustrated in Figure 19. In that diagram, note that the energy required to ignite methane at stoichiometric is 0.2 joules, compared to the energy required at its UEL, which is 3.5 joules. Different gases require different amounts of energy to ignite them; some require little, while others are almost impossible to ignite. The lower the ignition energy, the more dangerous the gas is to the system and its surroundings.

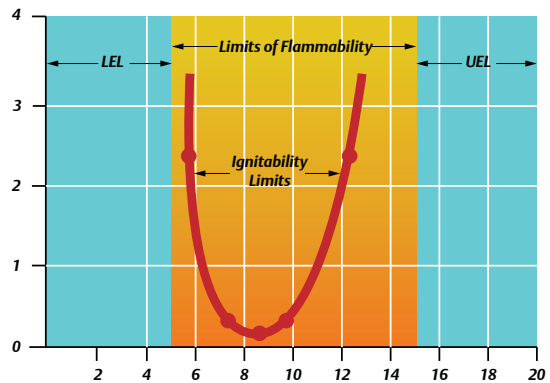

Figure 19. Energy required for Methane ignition

The ignition source is the starting point for measuring the most important variable for flame arrestor selection, which is the distance to the arrestor. Therefore the user must know the locations of all potential ignition sources relative to the arrestor.

High-Energy Ignition

Typical ignition sources have energy levels which are considered to be low, meaning just enough energy to ignite the combustible gas mixture. A high-energy ignition source, on the other hand, can cause the flame to be in a more severe state of propagation within a given length or L/D ratio than a low-energy source. The flame can actually skip the low, medium and high-pressure deflagration states and jump directly into detonation. Such behavior represents an exception to the conventional theory of flame propagation which was outlined earlier here. There are no established standards to differentiate between normal ignition energy and high-energy ignition. However, lightning strike, vessel explosion and burner chamber explosion are all considered to be high-energy ignitions.

Since a high-energy ignition changes the way a flame propagates, the rules for selecting a flame arrestor product also change. For example, consider a deflagration flame arrestor in a typical flare application for which it is designed—a 20-foot stack for a group “D” gas with flame arrestor near the base of the flare. If the process stream velocity falls below the burn-back velocity of the gas at the

Flame Arrestor Technology

tip, a flashback could occur. Since the length of pipe from the tip of the flare (ignition source) to the arrestor is relatively short, the flame dynamics will probably be no more severe than a medium-pressure deflagration and thus the deflagration flame arrestor will quench the flame. However, if the flare is struck by lightning (high energy ignition) while the flow is below burn-back velocity, the flame could be in a more severe state when it reaches the flame arrestor, such as high-pressure deflagration or overdriven detonation. In that case, the flame arrestor will probably fail, because it is not designed for a high-pressure deflagration or detonation. If there is a chance for high-energy ignition, an unstable detonation flame arrestor should be used instead of a standard deflagration flame arrestor.

Enriched Oxygen

In most vapor control systems, the source of oxygen in the combustible mixture is ambient air. However, some processes have a larger content of oxygen than standard air-gas mixture. Passive flame arrestor products discussed here are not designed for the more dangerous and severe condition of enriched oxygen.

Dust Versus Gas

When pulverized into dust suspended in air, combustible solids burn, propagate in piping and explode much like combustible gases. Passive flame arrestor products discussed here are not designed for use with flammable dust suspensions because of special concerns such as plugging.

Selecting End-Of-Line Flame Arrestors

As explained before, end-of-line deflagration flame arrestors are designed for unconfined flame propagation, also referred to as atmospheric explosion or unconfined deflagration. They simply bolt or screw onto the process or tank connection. These designs incorporate well-established but simple technology. Most use a single element of crimped wound metal ribbon that provides the heat transfer needed to quench the flame before it gets through the arrestor element.

The main points of concern when selecting an arrestor for end-of-line applications are as follows:

1. Hazardous group designation or MESH value of the gas
2. Flame stabilization performance characteristics of the arrestor compared to the system potential for flame stabilization for sustained periods of time
3. Process gas temperature
4. Pressure drop across the arrestor during venting flow conditions, relative to the system's maximum allowable pressure and vacuum
5. Materials of construction that meet the ambient and process conditions – for example, extremely cold climate, salt spray, chemically aggressive gas, etc.
6. Connection type and size
7. Instrumentation requirements

Selecting In-Line Flame Arrestors

The various dynamic states explained earlier for confined flames can be very dangerous for a process system due to the tremendous energies associated with detonation pressure and flame velocity. Things happen fast and can turn catastrophic. These multiple dynamic states increase the challenge of providing a flame arrestor product or products which stop the flame and withstand the enormous pressures caused by explosions within the confined piping.

The very wide range of possible behavior for a confined flame causes two particular problems for flame arrestor products. First, the high-pressure deflagration and stable detonation states have very stable kinetics of burning and the flame is moving very fast. Therefore the arrestor must be able to absorb the flame's heat much faster than is required by standard low-to-medium-pressure deflagration conditions. Second, the instantaneous impulse pressures caused by the shock waves of overdriven detonation subject the arrestor to forces of up to 20,995 kPa(g) / 3000 psig. Thus, the arrestor must be structurally superior to standard low-pressure deflagration arrestors.

Confined Deflagration Flame Arrestors

In-line deflagration flame arrestors are designed for confined flame propagation, also referred to as flashback or confined deflagrations. Like the end-of-line variety, flame arrestors of this type have been used in numerous applications for many decades. They resemble end-of-line flame arrestors in many ways. However, things are much different for these arrestors, because they are subject to more severe flame states. For almost every state of flame, there is a special type of arrestor. For example, a standard in-line deflagration flame arrestor is designed to stop flame propagation in short lengths of pipe, involving low-pressure and medium-pressure deflagrations. The high-pressure deflagration flame arrestor is an enhanced version of the standard deflagration flame arrestor, designed to stop flames in the low, medium and high pressure deflagration states.

Detonation Flame Arrestors

Since the early 1990s, detonation arrestors were developed and tested in accordance with the requirements of Appendix-A to Part 154 of 33 CFR, commonly called the “U.S. Coast Guard Standard” (USCG). These arrestors received USCG approval in 2 to 20 in. sizes, concentric and eccentric designs, with models for Group-D (IIA) and models for Group-C (IIB3) flammable vapors. Detonation arrestors approved to this standard must pass both stable and unstable detonations in addition to meeting other requirements, in other words, the most severe flame stage. There is no provision in this standard for detonation arrestors that are approved for stable detonations only.

The “U.S. Coast Guard Standard” was used as a guideline when developing a detonation flame arrestor for the European market. EN 12874 does allow detonation arrestors to be classified for stable detonations only, however, Emerson believes that determining the location where the flame propagation transitions to a stable detonation is unpredictable. During testing in a controlled system all phases of flame propagation can be mapped. But in real life there are many variables, (fuel mixtures, temperature, pressure, pipe layout etc) which may lead to a situation where a galloping detonation may occur.

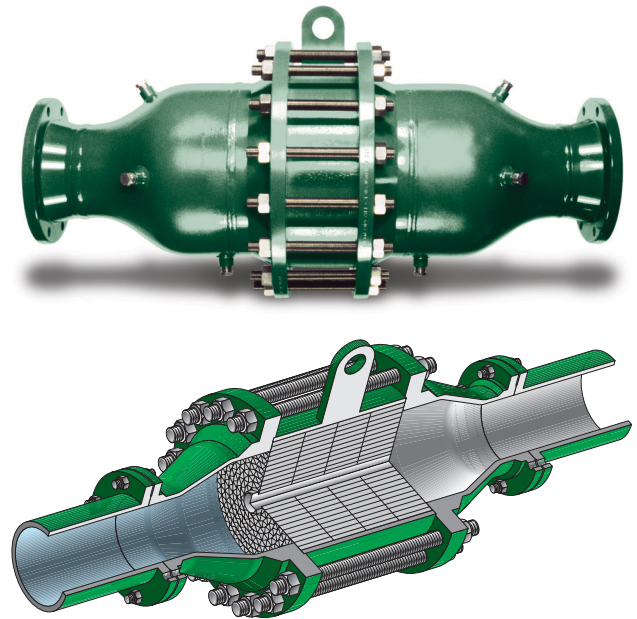

Figure 20. Enardo™ DFA detonation flame arrestor

Our belief is that the state of a detonation is unpredictable and therefore only those DFA's approved for unstable detonations should be specified.

None of the deflagration arrestor designs can withstand a detonation. Therefore the detonation flame arrestor was designed (see Figure 20). It has the heat transfer capacity and structural design to withstand all the dynamic conditions of flame propagation and still stop the flame. The detonation flame arrestor is the ultimate flame-stopping product and is used when the flame can be in any of the detonation states.

These capabilities do not come without some trade-offs. Detonation flame arrestors impose higher pressure drops than deflagration flame arrestors due to heat-transfer requirements, they are heavier because of structural requirements and they are typically more expensive. Therefore in-line deflagration flame arrestors will always have a place in industry.

The main points of concern when selecting an arrestor device for in-line applications are the same as listed before for end-of-line applications, except for one additional consideration: the L/D ratio and piping configuration between the arrestor and the potential ignition source.

Flame Arrestor Technology

Gas Group Chart

(As defined by NFPA 321, NEC and IEC)

Group A

Acetylene

Group B

Butadiene

Ethylene oxide

Formaldehyde

Hydrogen

Manufactured gasses containing more than
30% Hydrogen (by volume)

Propylene oxide

Propyl nitrate

Group C (IIB3)

Acetaldehyde

Cyclopropane

Diethyl ether

Dimethyl hydrazine

Ethylene

Hydrogen sulfide

Methanol (methyl alcohol)⁽¹⁾

Methyl mercaptan

Tetrahydrofuran

Unsymmetrical dimethylhydrazine (UDMH)

Group D (IIA)

Acetone

Acrylonitrile

Ammonia

Benzene

Butane

Butylene

1-Butanol (butyl alcohol)

2-Butanol (secondary butyl alcohol)

Cyclohexane

N-Butyl acetate

Group D (IIA) (continued)

Isobutyl acetate

Ethane

Ethanol (ethyl alcohol)

Ethyl acetate

Ethyl acrylate

Ethylene dichloride

Gasoline

Heptanes

Hexanes

Isoprene

Methane (natural gas)

Methyl acrylate

Methylamine

Methyl Ethyl Ketone

3-Methyl - 1-Butanol (isoamyl alcohol)

Methyl Isobutyl Ketone

2-Methyl - 1-Propanol (isobutyl alcohol)

2-Methyl - 2-Propanol (tertiary isobutyl alcohol)

Naphtha (petroleum)

N-Propyl acetate

Octanes

Pentanes

1-Pentanol (amyl alcohol)

Propane

1-Propanol (propyl alcohol)

2-Propanol (isopropyl alcohol)

Propylene

Styrene

Toluene

Turpentine

Vinyl acetate

Vinyl chloride

Xylenes

1. Emerson recommendation

Enardo IL Series

Threaded In-Line Flame Arrestor

Introduction

Enardo™ IL Series are designed to stop the propagation of confined low pressure deflagrations. The In-line series prevent flame propagation by absorbing and dissipating heat using spiral wound crimped ribbon flame cells. These cells allow maximum flow with maximum protection.

The Enardo IL Series are typically used for end-of-line and near end-of-line applications when the system operating pressure is near atmospheric levels and when there is minimal probability of a flame stabilizing on the Flame Arrestor element for an extended period. Typical applications include small fuel-assist lines, waste gas on reboilers and small instrumentation lines.

Designed with threaded connections. Standard housing construction is aluminum, carbon steel and stainless steel. The element is available in aluminum or stainless steel. Special material and protective coatings are available on request.

Sizes Available

Gas Group D (IIA): 1/2 to 4 in. / 13 to 100 mm

Construction Materials

Housing: Aluminum (1/2, 3/4 and 1 in. only), Carbon steel and Stainless steel

Cell: Aluminum, 304 Stainless steel, 316 Stainless steel, Hastelloy®

Gas Group: D (IIA)

Additional Technical Data

For more technical information, contact your local Sales Office or log on to:

www.enardo.com

Features

- Maximum Flow
- Less Pressure Drop
- Easy Cleaning
- Less Clogging
- Less Maintenance
- Single Element Design
- Readily accessible and removable flame cell for easy inspection and service (Enardo 602 and larger sizes)
- Economical design
- Bi-directional design
- Available in ANSI, DIN and JIS flanges



Figure 1. Threaded In-Line Flame Arrestor

Key to Enardo IL Series Model Number

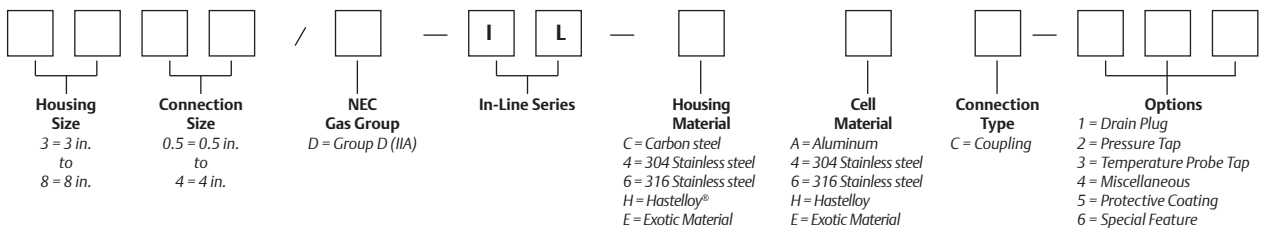

Example:



Indicates a Threaded In-Line Flame Arrestor with a 4 in. housing and 2 in. coupling connections. Carbon steel housing material and 304 Stainless steel NEC Group “D” flame cell element.

Hastelloy® is a mark owned by Haynes International, Inc.

Enardo IL Series

Threaded In-Line Flame Arrestor

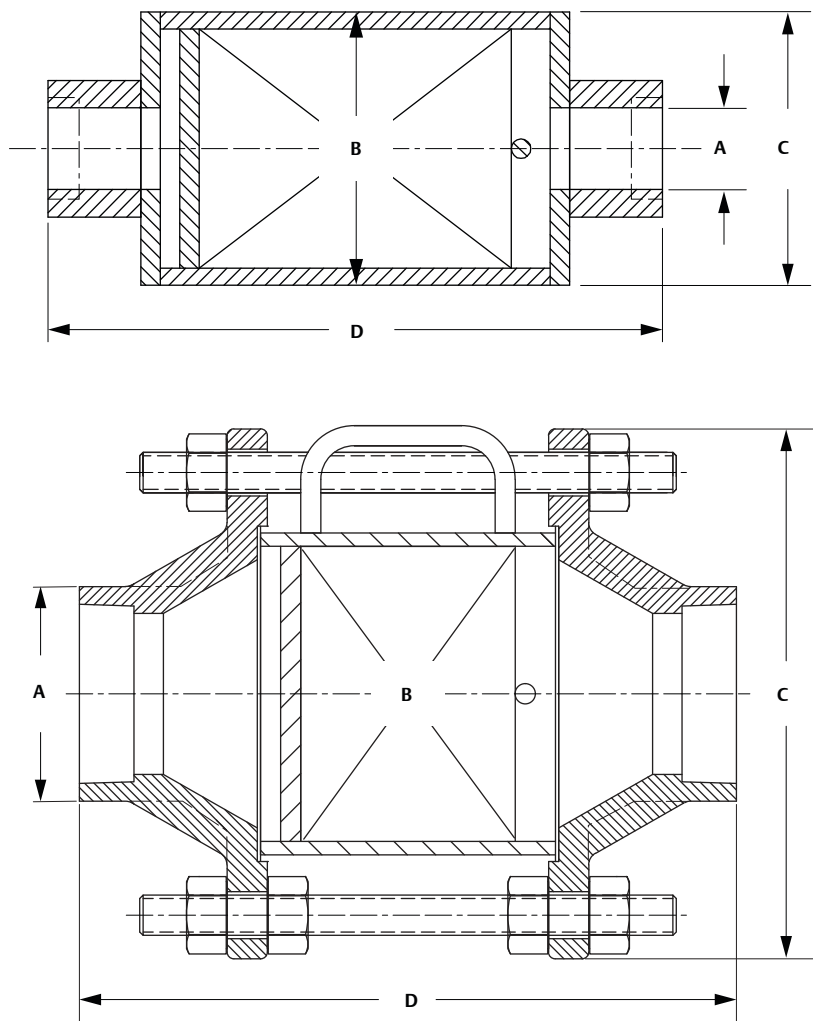

Figure 2. Threaded In-Line Flame Arrestor Dimensions

Table 2. Threaded In-Line Flame Arrestor Dimensions⁽¹⁾

MODEL	A (CONNECTION SIZE)		B (HOUSING SIZE)		C (OUTSIDE DIAMETER)		D (OVERALL LENGTH)		APPROXIMATE WEIGHT (ALUMINUM BODY/CELL)		APPROXIMATE WEIGHT (ALUMINUM CELL)		APPROXIMATE WEIGHT (STAINLESS STEEL)	
	In.	mm	In.	mm	In.	mm	In.	mm	Lbs	kg	Lbs	kg	Lbs	kg
Enardo™ 300.5-IL	0.5	12	3.5	90	3.5	90	7.38	187.5	10	4.5	20	9	25	11
Enardo 300.75-IL	0.75	19	3.5	90	3.5	90	7.50	190.5	10	4.5	20	9	25	11
Enardo 301-IL	1	25	3.5	90	3.5	90	7.88	200.2	10	4.5	20	9	25	11
Enardo 402-IL	2	50	4.5	115	4.5	115	8.50	215.9	N/A	N/A	30	14	35	16
Enardo 602-IL	2	50	6	150	10.38	264	10.5	267	N/A	N/A	43	20	50	23
Enardo 603-IL	3	75	6	150	10.38	264	12.25	311	N/A	N/A	45	21	52	24
Enardo 804-IL	4	100	8	200	12.5	318	13.13	333	N/A	N/A	62	28	73	33

1. Dimensions may vary somewhat from those given above. Allow for a tolerance of ± 1.00 in. / 25 mm. Threaded In-Line lengths vary depending on materials used. Specific dimensions available on request.

Enardo 8800 and Enardo 9900

Vent Stack Flame Arrestor

Introduction

Enardo™ 8800 and Enardo 9900 vent stack flame arrestors are designed to allow free venting in combination with flame protection for vertical vent applications. They prevent flame propagation by absorbing and dissipating heat using spiral wound crimped ribbon flame cells. These cells allow maximum flow with maximum protection. The vent stack flame arrestor is used to stop the propagation of confined and unconfined low pressure deflagrations. It prevents an ignited atmospheric vapor cloud from propagating beyond the flame arrestor into the vent line or tank.

This product is installed at the top of an atmospheric vent line or storage tank. They are typically used for the end-of-line applications when the system operating pressure is near atmospheric levels and when there is minimal probability of a flame stabilizing on the flame arrestor element for an extended period.

Vent stack flame arrestors allow free venting and flame protection for vertical vent applications. Designed with threaded NPT connections, this arrestor allows removal of the flame cell element without the removal of the venting assembly. Standard housing construction is aluminum, carbon steel and stainless steel. The element is available in aluminum or stainless steel.

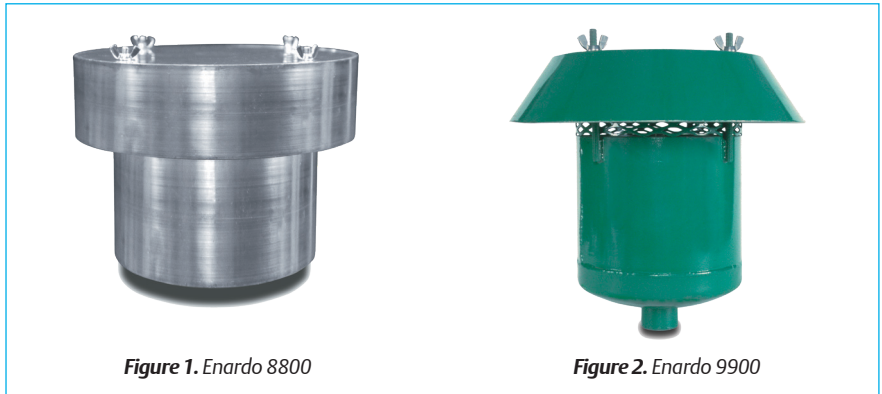

Figure 1. Enardo 8800

Figure 2. Enardo 9900

Model Numbers

Enardo 8800
Enardo 9900

Sizes Available

1 to 6 in. / 25 to 150 mm nominal pipe size

Construction Materials

Housing

Enardo 8800: Aluminum
Enardo 9900: Carbon Steel, 304 Stainless steel, 316 Stainless steel

Cell: Aluminum, 304 Stainless steel, 316 Stainless steel

Gas Group: D (IIA)

Additional Technical Data

For more technical information, contact your local Sales Office or log on to:

www.enardo.com

Features

- Maximum Flow
- Less Pressure Drop
- Easy Cleaning
- Less Clogging
- Less Maintenance
- Single Element Design
- Readily accessible and removable flame cell for easy inspection and service
- Flanged design available in ANSI, DIN and JIS flanges

Key to Enardo 8800 and Enardo 9900 Model Number

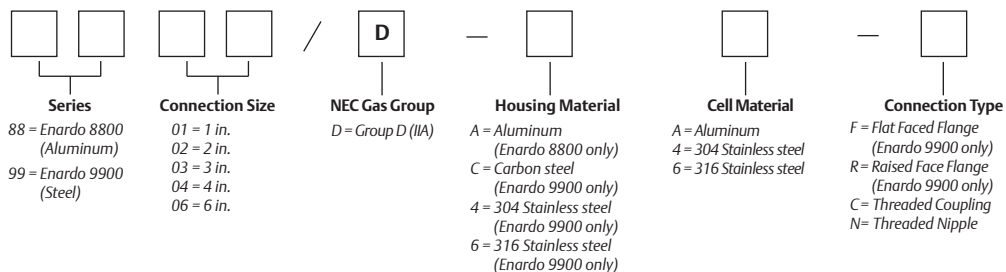

Example:



Indicates an Enardo 8800 Vent Flame Arrestor with an aluminum housing, a 2 in. threaded coupling and 304 Stainless steel NEC Group "D" flame cell element.

Enardo 8800 and Enardo 9900

Vent Stack Flame Arrestor

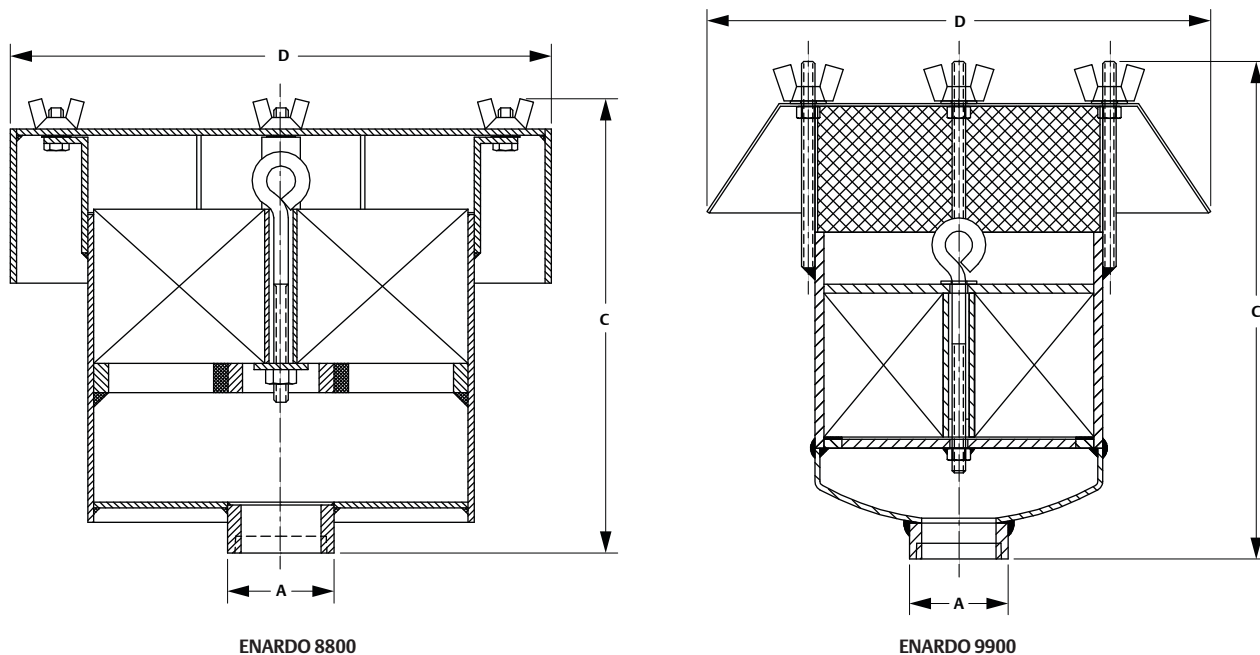

Figure 3. Enardo™ 8800 and Enardo 9900 Dimensions

Table 1. Enardo 8800 Dimensions

MODEL	A (CONNECTION SIZE)		C (OVERALL HEIGHT)		D (OUTSIDE DIAMETER)	
	In.	mm	In.	mm	In.	mm
Enardo 8802	2	50	14-3/8	365	14	356
Enardo 8803	3	75	14-3/8	365	14	356
Enardo 8804	4	100	14-3/8	365	14	356
Enardo 8806	6	150	14-3/8	365	16	406

Table 2. Enardo 9900 Dimensions

MODEL	A (CONNECTION SIZE)		C (OVERALL HEIGHT)		D (OUTSIDE DIAMETER)	
	In.	mm	In.	mm	In.	mm
Enardo 9902	2	50	14-3/8	365	14	356
Enardo 9903	3	75	14-3/8	365	14	356
Enardo 9904	4	100	14-3/8	365	14	356
Enardo 9906	6	150	14-3/8	365	16	406

Enardo FVFA Series

Free Vent Flame Arrestor

Introduction

Enardo™ FVFA Series free vent flame arrestors are designed to allow free venting in combination with flame protection for vertical vent applications. This product is installed at the top of an atmospheric vent line or storage tank. They prevent flame propagation by absorbing and dissipating heat using spiral wound crimped ribbon flame cells. These cells allow maximum flow with maximum protection. The FVFA is used to stop the propagation of confined and unconfined low pressure deflagrations. It prevents an ignited atmospheric vapor cloud from propagating beyond the flame arrestor into the vent line or tank.

FVFA's are typically used for the end of line applications when the system operating pressure is near atmospheric levels and when there is minimal probability of a flame stabilizing on the flame arrestor element for an extended period.

Free vent flame arrestors allow free venting and flame protection for vertical vent applications. Designed with flanged connections, this arrestor allows removal of the flame cell element without their removal of the venting assembly. Standard housing construction is aluminum, carbon steel and stainless steel. The element is available in aluminum or stainless steel. Special material and protective coatings are available on request.

ISO-16852 Certified 2 to 12 in. / 50 to 300 mm IIA (D) and IIB3 (C).



Figure 1. Enardo FVFA

Models and Connection Sizes Available

FVFA:

3/4 through 36 in. / 20 through 900 mm

EN FVFA-ISO 16852 Approved:

2 to 12 in. / 50 to 300 mm

Construction Materials

Housing: Aluminum, Carbon steel, 304 Stainless steel, 316 Stainless steel and Hastelloy®

Cell: Aluminum, 304 Stainless steel, 316 Stainless steel and Hastelloy®

Gas Group

D (IIA), C (IIB3) and B (IIC)

Additional Technical Data

For more technical information, contact your local Sales Office or log on to:

www.enardo.com

Features

- Maximum Flow
- Less Pressure Drop
- Easy Cleaning
- Less Clogging
- Less Maintenance
- Single Element Design
- Fluoropolymer Coated Hardware Provides Outstanding Corrosion and Chemical Resistance
- Easy Accessible and Removable Flame Cell for Easy Inspection and Service
- Standard Temperature Probe on EN Models
- Flanged Design Available in ANSI, DIN and JIS Flanges

Hastelloy® is a mark owned by Haynes International, Inc.

Enardo FVFA Series

Free Vent Flame Arrestor

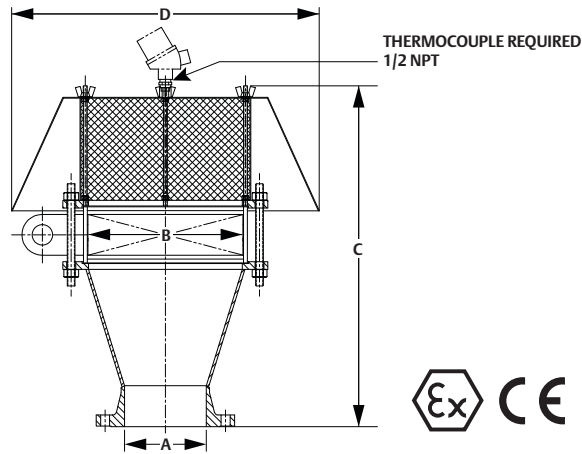

Figure 2. Enardo™ EN FVFA Dimensions

Table 1. Enardo EN FVFA Dimensions⁽¹⁾

MODEL	A (NOMINAL CONNECTION SIZE)		B (HOUSING SIZE)		C (HEIGHT)		D (OUTSIDE DIAMETER)		APPROXIMATE WEIGHT	
	In.	mm	In.	mm	In.	mm	In.	mm	Lb	kg
Enardo EN 0402	2	50	4	100	16.94	430	12	305	59.5	27
Enardo EN 0602	2	50	6	150	18	457	18	457	62	28.5
Enardo EN 0603	3	75	6	150	18	457	18	457	66	30
Enardo EN 0803	3	75	8	200	17.13	455	18	457	80	36.3
Enardo EN 0804	4	100	8	200	18.13	460	18	457	90	41
Enardo EN 1204	4	100	12	300	24.5	622	22	559	142	64.4
Enardo EN 1206	6	150	12	300	25	635	22	559	450	68
Enardo EN 1606	6	150	16	400	32.88	822	30	762	287	130
Enardo EN 1608	8	200	16	400	33.38	848	30	762	298	135
Enardo EN 2008	8	200	20	500	35.75	908	36	914	434	197
Enardo EN 2010	10	250	20	500	35.75	908	36	914	443	201
Enardo EN 2410	10	250	24	600	39	990	44	1118	653	296
Enardo EN 2412	12	300	24	600	39.5	1005	44	1118	675	306

1. Dimensions may vary somewhat from those given above. Allow for a tolerance of ± 1.00 in. / 25 mm. Specific dimensions available on request.

Key to Enardo EN FVFA Model Number

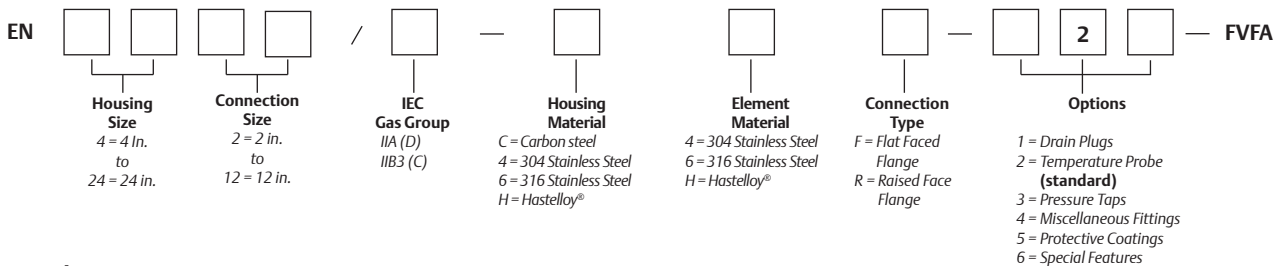

Example:



Indicates a Free Vent Flame Arrestor with a 20 in. Carbon steel housing and 10 in. raised faced flange connection and a 304 Stainless steel IEC Group “IIA” flame cell element. It also has an additional option of a protective coating for corrosive service and standard temperature probe.

Hastelloy® is a mark owned by Haynes International, Inc.

Enardo FVFA Series

Free Vent Flame Arrestor

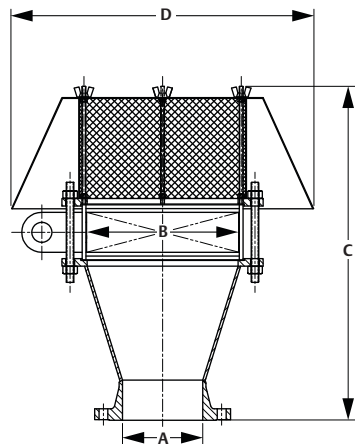

Figure 3. Standard Enardo™ FVFA Dimensions

Table 2. Standard Enardo FVFA Dimensions⁽¹⁾

MODEL	A (NOMINAL CONNECTION SIZE)		B (HOUSING SIZE)		C (HEIGHT)		D (OUTSIDE DIAMETER)		APPROXIMATE WEIGHT	
	In.	mm	In.	mm	In.	mm	In.	mm	Lb	kg
Enardo 401	1	25	4	100	16.63	422	12	305	50	23
Enardo 402	2	50	4	100	17	432	12	305	52	23.5
Enardo 602	2	50	6	150	18	457	18	457	54	24.5
Enardo 802	2	50	8	200	18	457	18	457	77	34.9
Enardo 803	3	75	8	200	18	457	18	457	81	36.7
Enardo 804	4	100	8	200	18	457	18	457	86	39.0
Enardo 1206	6	150	12	300	25.00	635	22	559	149	67.6
Enardo 1608	8	200	16	400	33.38	848	30	762	243	110.2
Enardo 2010	10	250	20	500	35.75	908	36	914	360	163.3
Enardo 2412	12	300	24	600	39.50	1003	44	1118	549	249.0

1. 14 to 36 in. / 350 to 900 mm and over – Dimensions available on request. Dimensions may vary somewhat from those given above. Allow for a tolerance of ±1.00 in. / 25 mm. Specific dimensions available on request.

Key to Enardo FVFA Model Number

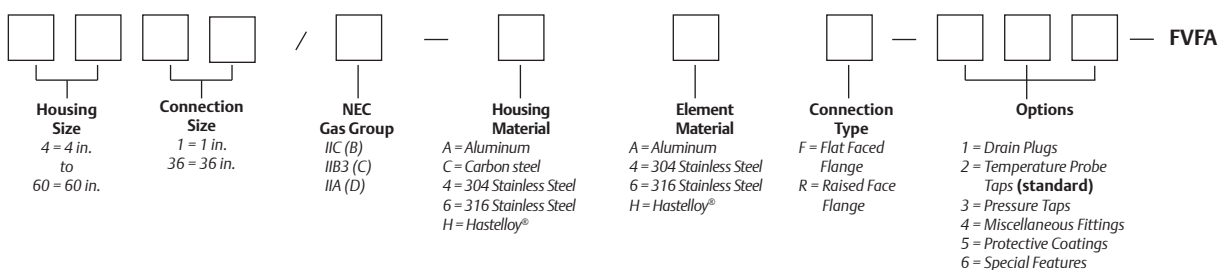

Example:

2 0 1 0 / D — A 4 F — 5 — FVFA

Indicates a Free Vent Flame Arrestor with a 20 in. Aluminum housing and 10 in. flat faced flange connection and a 304 Stainless steel NEC Group “D” flame cell element. It also has an additional option of a protective coating for corrosive service.

Hastelloy® is a mark owned by Haynes International, Inc.

Enardo 7 Series

Deflagration Flame Arrestor

Introduction

Enardo™ 7 Series deflagration flame arrestors are designed to stop the propagation of confined low pressure deflagrations. The Enardo 7 Series is typically used for end-of-line and near end-of-line applications when the system operating pressure is near atmospheric levels and when there is minimal probability of a flame stabilizing on the Flame Arrestor element for an extended period.

The Enardo 7 Series prevents flame propagation by absorbing and dissipating heat using spiral wound crimped ribbon flame cells. These cells allow maximum flow with maximum protection.

Designed with flanged connections, this arrestor allows removal of the flame cell element for easy cleaning and replacement without removing the arrestor body from the pipe connection. Standard housing construction is Aluminum, Carbon steel and Stainless steel. The element is available in Aluminum or Stainless steel. Special material and protective coatings are available on request.

ISO-16852 Certified 1 in. / 25 mm through 12 in. / 300 mm, D (IIA) and C (IIB3).

Factory Mutual Approved 2 in. / 50 mm to 12 in. / 300 mm, D (IIA).



Figure 1. Enardo 7 Series

Models and Available Sizes

Enardo 7 Series Deflagration Flame Arrestor: 1 to 36 in. / 25 to 900 mm

Enardo EN-7 Series ISO-16852 Certified: 1 to 12 in. / 25 to 300 mm⁽¹⁾

Enardo 7 Series Factory Mutual Approved: 2 to 12 in. / 50 to 300 mm

Construction Materials

Housing: Aluminum, Carbon steel, 304 Stainless steel, 316 Stainless steel and Hastelloy®

Cell: Aluminum, 304 Stainless steel, 316 Stainless steel, Hastelloy® and Exotic

Gas Group

D (IIA), C (IIB3) and B (IIC)

Additional Technical Data

For more technical information, contact your local Sales Office or log on to:

www.enardo.com

Features

- Maximum Flow
- Less Pressure Drop
- Easy Cleaning
- Less Clogging
- Less Maintenance
- Single Element Design
- Fluoropolymer Coated Hardware Provides Outstanding Corrosion and Chemical Resistance
- Easy Accessible and Removable Flame Cell for Easy Inspection and Service
- Bi-directional Design
- Standard Temperature Probe on EN Models
- Available in ANSI, DIN and JIS Flanges

Hastelloy® is a mark owned by Haynes International, Inc.
1. Available in carbon steel and stainless steel only.

EN Certified Model

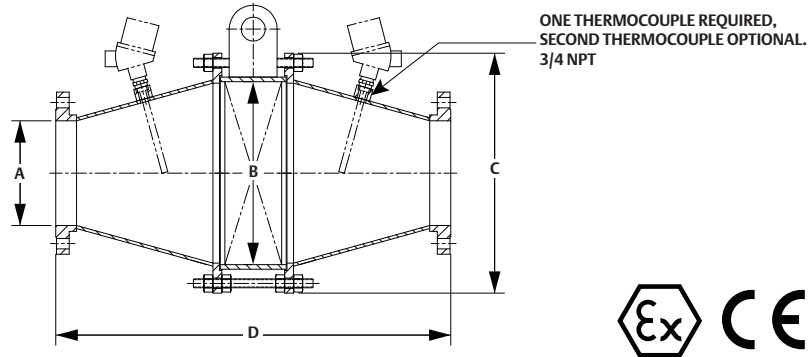

Figure 2. Enardo™ EN-7 Series Flame Arrestor Dimensions

Table 1. Enardo EN-7 Series Flame Arrestor Dimensions⁽¹⁾

MODEL	A (NOMINAL CONNECTION SIZE)		B (HOUSING SIZE)		C (OUTSIDE DIAMETER)		D (OVERALL LENGTH)		APPROXIMATE WEIGHT	
	In.	mm	In.	mm	In.	mm	In.	mm	Lbs	kg
Enardo EN-70402	2	50	4	100	7.75	197	15.25	387	65	29.5
Enardo EN-70602	2	50	6	150	10.25	260	16	406	68	31
Enardo EN-70603	3	75	6	150	10.25	260	16	406	72	32.5
Enardo EN-70803	3	75	8	200	12	305	16	406	95	43
Enardo EN-70804	4	100	8	200	12	305	16	406	101	46
Enardo EN-71204	4	100	12	300	16	406	21	533	168	76
Enardo EN-71206	6	150	12	300	16	406	21	533	181	82
Enardo EN-71606	6	150	16	400	20	508	33	838	278	126
Enardo EN-71608	8	200	16	400	20	508	33	838	298	135
Enardo EN-72008	8	200	20	500	24	610	38	965	386	175
Enardo EN-72010	10	250	20	500	24	610	38	965	443	201
Enardo EN-72410	10	250	24	600	29	737	41	1041	622	282
Enardo EN-72412	12	300	24	600	29	737	41	1041	672	305

1. Dimensions may vary somewhat from those given above. Allow for a tolerance of ± 1.00 in. / 25 mm. Specific dimensions available on request.

Key to Enardo EN-7 Series Flame Arrestor Model Number

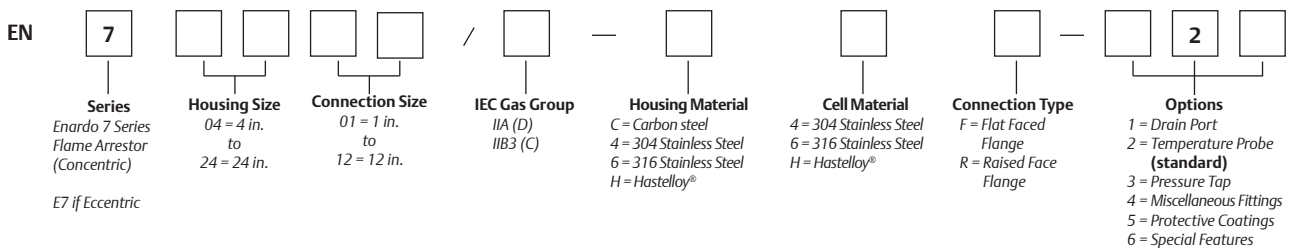

Example:



Indicates a 10 in. Concentric Enardo EN-7 Series Deflagration Flame Arrestor with a 20 in. Carbon steel housing. ANSI 150 lbs. raised faced flange connections and 304 Stainless steel IEC Group "IIA" flame cell element. It also has additional options of drain plugs and standard temperature probe.

Hastelloy® is a mark owned by Haynes International, Inc.

Enardo 7 Series

Deflagration Flame Arrestor

Carbon Steel and Stainless Steel Housings

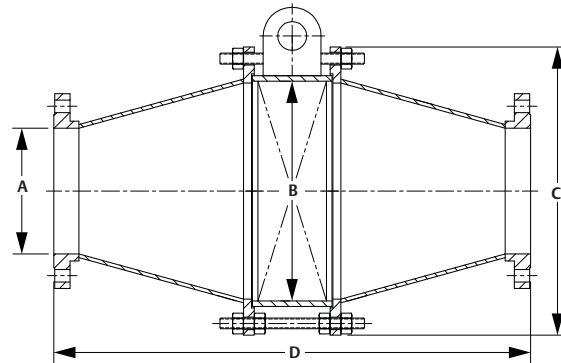

*Not all models are available with FM approval. Consult Flame Arrester Certifications page for more information.

Figure 3. Standard Enardo™ 7 Series Flame Arrester Dimensions

Table 2. Standard Enardo 7 Series Flame Arrester Dimensions⁽¹⁾

MODEL	A (NOMINAL CONNECTION SIZE)		B (HOUSING SIZE)		C (OUTSIDE DIAMETER)		D (OVERALL LENGTH)		APPROXIMATE WEIGHT (GROUP D MODELS)	
	In.	mm	In.	mm	In.	mm	In.	mm	Lbs	kg
Enardo 70401	1	25	4	100	7.75	197	15.63	397	60	27
Enardo 70402	2	50	4	100	7.75	197	15.25	387	63	29
Enardo 70602	2	50	6	150	10.25	260	16	406	66	30
Enardo 70802	2	50	8	200	12	305	16	406	85	38.6
Enardo 70603	3	75	6	150	10.25	260	16	406	70	31.8
Enardo 70803	3	75	8	200	12	305	16	406	90	40.8
Enardo 70804	4	100	8	200	12	305	16	406	95	43.1
Enardo 71006	6	150	10	250	14	356	21	533	135	61.2
Enardo 71206	6	150	12	300	16	406	21	533	165	74.8
Enardo 71408	8	200	14	350	18	457	25	635	225	102.1
Enardo 71608	8	200	16	400	20	508	33	838	270	122.5
Enardo 71810	10	250	18	450	22	559	30	762	335	152.0
Enardo 72010	10	250	20	500	24	610	38	965	400	181.4
Enardo 72212	12	300	22	550	26	660	34	863	477	216
Enardo 72412	12	300	24	600	29	737	41	1041	590	268

1. 14 inches to 36 in. and over – Dimensions available on request. Dimensions may vary somewhat from those given above. Allow for a tolerance of ±1.00 in. / 25 mm. Specific dimensions available on request.

Key to Enardo 7 Series Flame Arrester Model Number

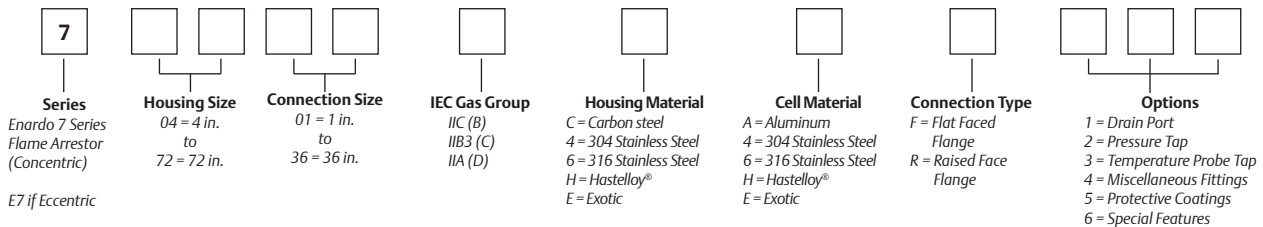

Example:

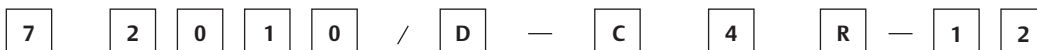

Indicates a 10 in. Concentric Enardo 7 Series Deflagration Flame Arrestor with a 20 in. Carbon steel housing, ANSI 150 lbs. raised faced flange connections and 304 S tainless steel NEC Group “D” flame cell element. It also has additional options of drain plugs and temperature probe taps.

Hastelloy® is a mark owned by Haynes International, Inc.



Aluminum Housing

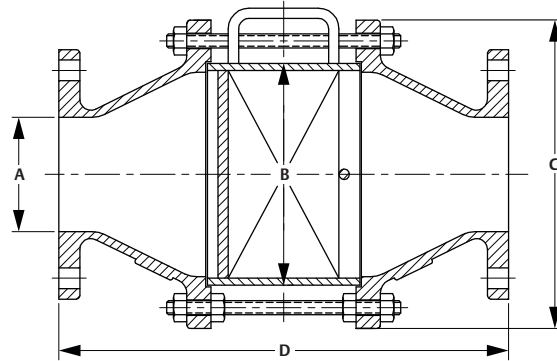

Figure 4. Cast Aluminum Enardo™ 7 Series Flame Arrestor Dimensions

Table 3. Cast Aluminum Enardo 7 Series Flame Arrestor Dimensions⁽¹⁾

MODEL	A (NOMINAL CONNECTION SIZE)		B (HOUSING SIZE)		C (OUTSIDE DIAMETER)		D (OVERALL LENGTH)		APPROXIMATE WEIGHT WITH ALUMINUM CELL (GROUP D MODELS)		APPROXIMATE WEIGHT WITH STAINLESS STEEL CELL (GROUP D MODELS)	
	In.	mm	In.	mm	In.	mm	In.	mm	Lbs	kg	Lbs	kg
Enardo 70802	2	50	8	200	11.13	283	16.50	419	24	10.9	33	15.0
Enardo 70803	3	75	8	200	11.13	283	16.50	419	27	12.2	36	16.3
Enardo 70804	4	100	8	200	11.13	283	16.50	419	31	14.1	40	18.1
Enardo 71006	6	150	10	250	13.13	334	21.50	546	46	20.9	73	33.1
Enardo 71206	6	150	12	300	15.13	384	21.50	546	60	27.2	85	38.6
Enardo 71408	8	200	14	350	17.13	435	25.63	651	80	36.3	113	51.3
Enardo 71608	8	200	16	400	19.13	486	25.50	648	95	43.1	138	62.6
Enardo 72010	10	250	20	500	24.38	619	30.63	778	180	81.6	245	111.1
Enardo 72212	12	300	22	550	26	660	34	863	190	86	255	116
Enardo 72412	12	300	24	600	29	737	41	1041	230	104	315	143

1. Dimensions may vary somewhat from those given above. Allow for a tolerance of ±1.00 in. / 25 mm. Specific dimensions available on request.

Key to Cast Aluminum Enardo 7 Series Flame Arrestor Model Number

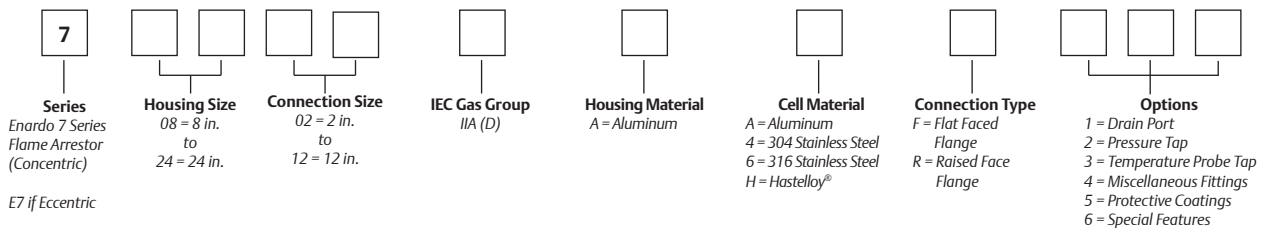

Example:

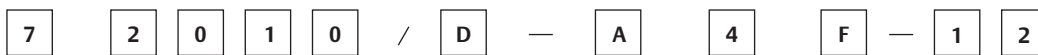

Indicates a Concentric Enardo 7 Series Deflagration Flame Arrestor with a 20 in. Aluminum housing, ANSI 10 in. flat faced flange connections and 304 Stainless steel NEC Group “D” flame cell element. It also has additional options of drain plugs and temperature probe taps.

Hastelloy® is a mark owned by Haynes International, Inc.

Enardo 8 Series

High Pressure Deflagration Flame Arrestor

Introduction

Enardo™ 8 Series high pressure deflagration flame arrestors are designed to protect against high velocity and pressure flame fronts inherent in applications beyond the performance range of a standard flame arrestor but not yet to the detonation phase of flame development and provide an economical alternative to a detonation arrestor. Enardo 8 Series are designed to surpass standard flame arrestors for applications that include extended lengths of pipe with one bend, elevated operating pressures and extended flame stabilization on the flame cell element. The arrestors are bi-directional and can stop low, medium and high pressure deflagrations. This design utilizes a superior element assembly that dampens the high velocities and pressures associated with deflagrations and detonations while quenching the flame front.

Our design is unique in the ability to provide larger flame channels which requires less frequent maintenance and greater ease in cleaning when service is required, translating to less down time. The element offers maximum flow to pressure drop characteristics enhancing the value of our product in any system.

Designed with flanged connections, this arrestor provides the option of the removal of the flame cell element for easy cleaning and replacement without disconnecting of the pipe connection. Standard housing construction is carbon steel and stainless steel. The element is available in stainless steel. Special material and protective coatings are available on request.

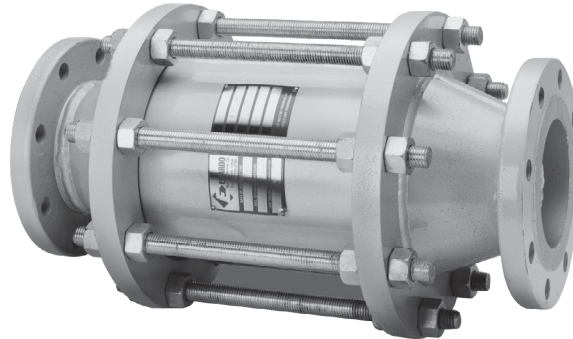

Figure 1. Enardo 8 Series High Pressure Deflagration Flame Arrestor

Flame Arrestor Specifications

Sizes Available

2 to 24 in. / 50 to 600 mm

Construction Materials

Housing

Carbon Steel
304 Stainless steel
316 Stainless steel
Hastelloy®
Exotic

Cell

304 Stainless steel
316 Stainless steel
Hastelloy®

Gas Group

B, C and D

Additional Technical Data

For more technical information, contact your local Sales Office or log on to:

www.enardo.com

Features

- **Maximum flow**
- **Less pressure Drop**
- **Easy Cleaning**
- **Less Clogging**
- **Less Maintenance**
- **Bi-Directional Design**
- **Removable Element design allows for easy inspection, cleaning and replacement**
- **Fluoropolymer coated hardware provides outstanding corrosion and chemical resistance**
- **Standard temperature ports**

Hastelloy® is a mark owned by Haynes International, Inc.

Enardo 8 Series

High Pressure Deflagration Flame Arrestor

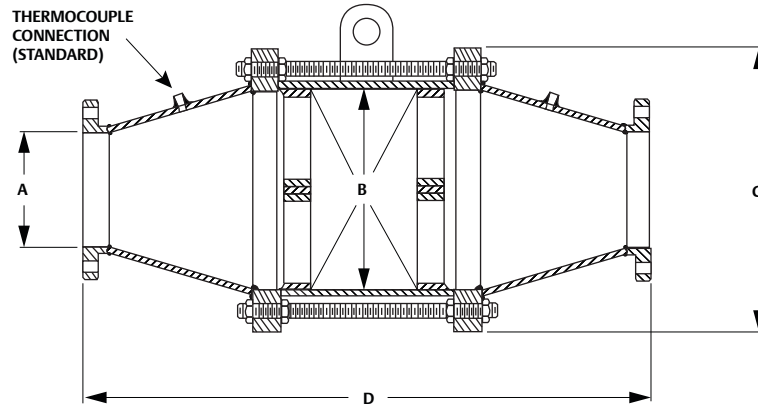

Figure 2. Enardo™ 8 Series Dimensions

Table 1. Enardo 8 Series Dimensions and Weights⁽¹⁾

MODEL	A (CONNECTION SIZE)		B (HOUSING SIZE)		C (OUTSIDE DIAMETER)		D (OVERALL LENGTH)				APPROXIMATE WEIGHT GAS GROUP D	
	In.	mm	In.	mm	In.	mm	Gas Group B/C		Gas Group D		Lbs	kg
							In.	mm	In.	mm		
Enardo 80802	2	50	8	200	12.00	305	22.50	572	20.50	521	123	55.8
Enardo 80803	3	75	8	200	12.00	305	22.50	572	20.50	521	125	56.7
Enardo 80804	4	100	8	200	12.00	305	22.50	572	20.50	521	130	59.0
Enardo 81206	6	150	12	300	17.00	432	29.00	737	29.00	737	335	152.0
Enardo 81608	8	200	16	400	21.50	546	43.00	1092	43.00	1092	645	292.6
Enardo 82010	10	250	20	500	26.00	660	46.00	1168	46.00	1168	960	435.4
Enardo 82412	12	300	24	600	30.00	762	49.00	1245	49.00	1245	1210	548.8

1. Dimensions may vary somewhat from those given above. Allow for a tolerance of ± 1.00 in. / 25 mm. Specific dimensions available on request

Key to Enardo 8 Series Deflagration Arrestor Model Number

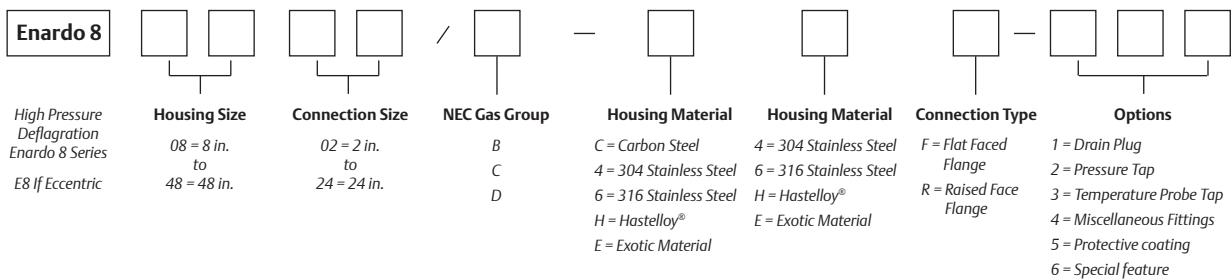

Example:



Indicates a 6 in. Concentric Enardo 8 Series High Pressure Deflagration Flame Arrestor with a 12 in. carbon steel housing, ANSI 150 lbs. raised face flange connections and 304 stainless steel NEC Group “D” flame cell element. It also has additional options of drain plugs and temperature probe taps.

Hastelloy® is a mark owned by Haynes International, Inc.

Enardo DFA Series

Detonation Flame Arrestor

Introduction

Enardo™ DFA Series detonation flame arrestors represent the best value in flame arrestor protection. They prevent flame propagation by absorbing and dissipating heat using spiral wound crimped ribbon flame cells. These cells allow maximum flow with maximum protection. They provide protection against flame propagation in piping systems that are manifolded or have long run-up distances. This design utilizes a superior element assembly that dampens the high velocities and pressures associated with deflagrations and detonations while quenching the flame front. Our design is unique in the ability to provide larger flame channels which requires less frequent maintenance and greater ease in cleaning when service is required, translating to less down time. The element offers maximum flow to pressure drop characteristics enhancing the value of our product in any system.

They are typically used for extended pipe length or multiple pipe bend configurations to stop high pressures and flame velocities associated with detonations and overdriven detonations. In addition, it stops confined and unconfined, low and high pressure deflagrations. All units are bi-directional and are proven to stop an ignited flammable vapor mixture approaching from either direction that can be traveling at subsonic or supersonic velocities.

Designed with flanged connections, this Arrestor provides the option of the removal of the flame cell element for easy cleaning and replacement without disconnecting of the pipe connection. Special material and protective coatings are available on request.

U.S. Coast Guard (USCG) Approved 1 to 24 in. / 25 to 600 mm IIA (D) and IIB3 (C) Concentric and Eccentric design.

EN 12874 ATEX Certified 1 to 24 in. / 25 to 600 mm IIA and IIB3 Concentric and Eccentric design.

Models

Enardo DFA Series
EN 12874 ATEX Certified
U.S. Coast Guard (USCG) Approved

Sizes Available

4 to 48 in. / 100 to 1200 mm
1 to 24 in. / 25 to 600 mm

Construction Materials

Housing: Carbon steel, 304 Stainless steel, 316 Stainless steel and Hastelloy®(1)

Element: 304 Stainless steel, 316 Stainless steel and Hastelloy®

Gas Group

IIA (D), IIB3 (C) and IIC (B)

Additional Technical Data

For more technical information, contact your local Sales Office or log on to:

www.enardo.com

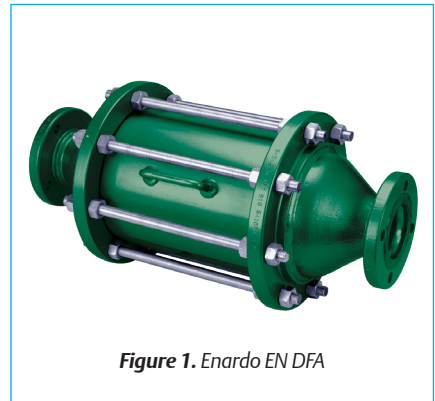

Figure 1. Enardo EN DFA

Features

- All Detonation Flame Arrestors are Designed for Unstable Detonations
- Removable Element Design Allows for Easy Inspection, Cleaning and Replacement
- Fluoropolymer Coated Hardware Provides Outstanding Corrosion and Chemical Resistance
- Standard Temperature Probe on EN Models
- Maximum Flow
- Less Pressure Drop
- Easy Cleaning
- Less Clogging
- Less Maintenance
- Bi-directional Design
- Available in ANSI, DIN and JIS Flanges

Hastelloy® is a mark owned by Haynes International, Inc.
1. Hastelloy® housings are not USCG approved.

ATEX Certified Model

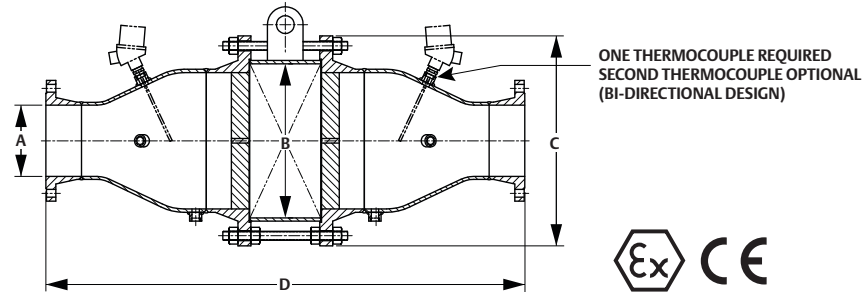

See Following Page For Additional ATEX Certified Models

Figure 2. Enardo™ EN DFA Series Dimensions

Table 1. Enardo EN DFA Series Dimensions⁽¹⁾

MODEL	A (NOMINAL CONNECTION SIZE)		B (HOUSING SIZE)		C (OUTSIDE DIAMETER)		D (OVERALL LENGTH)				APPROXIMATE WEIGHT (GROUP IIA MODELS)	
	In.	mm	In.	mm	In.	mm	Gas Group IIA		Gas Group IIB3		Lbs	kg
							In.	mm	In.	mm		
Enardo EN DFA-0402	2	50	4	101	7.5	188	25.3	644	23.3	593	80	36
Enardo EN DFA-0602	2	50	6.6	168	10	250	29.8	758	27.8	707	118	54
Enardo EN DFA-0603	3	75	6.6	168	10	250	30.3	771	28.3	720	125	57
Enardo EN DFA-0803	3	75	10	254	13.5	338	33.3	847	31.3	796	206	94
Enardo EN DFA-0804	4	100	10	254	13.5	338	33.8	859	31.8	809	215	98
Enardo EN DFA-1204	4	100	14	356	19	475	38.8	986	36.8	936	452	205
Enardo EN DFA-1206	6	150	14	356	19	475	39.8	1012	37.8	961	468	212
Enardo EN DFA-1606	6	150	18	457	23.5	588	52.8	1342	50.8	1291	874	396
Enardo EN DFA-1608	8	200	18	457	23.5	588	53.8	1367	51.8	1317	910	413
Enardo EN DFA-2008	8	200	22	559	27.5	688	67.2	1707	65.2	1656	1294	587
Enardo EN DFA-2010	10	250	22	559	27.5	688	67.2	1707	65.2	1656	1320	599
Enardo EN DFA-2410	10	250	26	660	32	800	67.8	1723	65.8	1672	1740	789
Enardo EN DFA-2412	12	300	26	660	32	800	68.8	1748	66.8	1698	1800	817

1. Dimensions may vary somewhat from those given above. Allow for a tolerance of ± 1.00 in. / 25 mm. Specific dimensions available on request.

Key to Enardo EN DFA Model Number

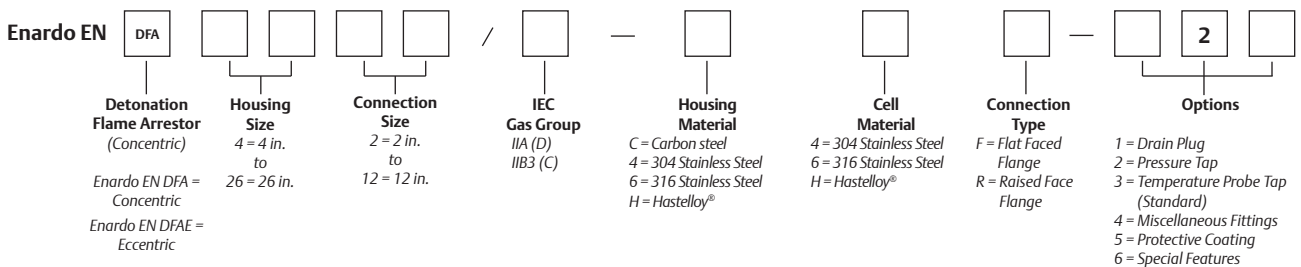

Example:



Indicates a 6 in. Concentric Enardo DFA with a 12 in. Carbon steel housing, ANSI 150 lb raised faced flange connection and a 304 Stainless steel IEC Group "IIA" flame cell element. It also has an options of drain plugs, pressure taps and standard temperature probe.

Hastelloy® is a mark owned by Haynes International, Inc.

Enardo DFA Series

Detonation Flame Arrestor

ATEX/US Coast Guard Certified Model*

OPTIONAL CONNECTIONS FOR DRAINAGE, TEMPERATURE, PRESSURE, ETC.

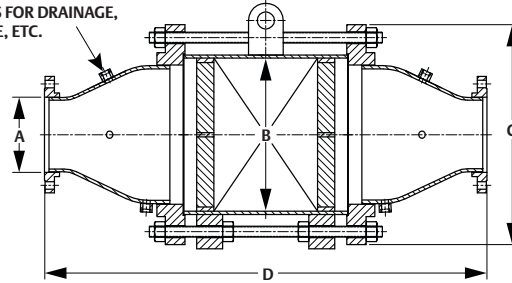

*Not all models are available with USCG and ATEX certifications. Consult Flame Arrestor Certifications Chart for more information.

Figure 3. Standard Enardo™ DFA Series Dimensions

Table 2. Standard Enardo DFA Series Dimensions⁽¹⁾

MODEL	A (NOMINAL CONNECTION SIZE)		B (HOUSING SIZE)		C (OUTSIDE DIAMETER)		D (OVERALL LENGTH)				APPROXIMATE WEIGHT (GROUP D MODELS)	
	In.	mm	In.	mm	In.	mm	Gas Group B/C		Gas Group D		Lbs	kg
							In.	mm	In.	mm		
Enardo DFA-0401	1	25	4	100	9.00	229	25.00	635	21.00	533	90	40.8
Enardo DFA-0602	2	50	6	150	11.00	279	28.00	711	24.00	610	175	79.4
Enardo DFA-0803	3	75	8	200	13.50	343	30.00	762	26.00	660	220	99.8
Enardo DFA-1004	4	100	10	250	16.00	406	32.00	813	32.00	813	400	181.4
Enardo DFA-1206	6	150	12	300	19.00	483	36.00	914	36.00	914	500	226.8
Enardo DFA-1608	8	200	16	400	25.50	648	51.25	1302	51.25	1302	1360	616.9
Enardo DFA-2010	10	250	20	500	30.50	775	62.75	1594	62.75	1594	1945	882.2
Enardo DFA-2412	12	300	24	600	36.00	914	64.50	1638	64.50	1638	3000	1360.8
Enardo DFA-2814	14	350	28	700	40.75	1035	70.00	1778	70.00	1778	3400	1542.2
Enardo DFA-3016	16	400	30	750	43.00	1092	79.00	2007	79.00	2007	3800	1723.7
Enardo DFA-3418	18	450	34	850	47.50	1207	89.00	2261	89.00	2261	4800	2177.2
Enardo DFA-3620	20	500	36	900	50.00	1270	89.00	2261	89.00	2261	5600	2540.1
Enardo DFA-4824	24	600	48	1200	59.50	1511	101.00	2565	101.00	2565	8700	3946.3

1. Dimensions may vary somewhat from those given above. Allow for a tolerance of ± 1.00 in. / 25 mm. Specific dimensions available on request.

Key to Enardo DFA Series Model Number

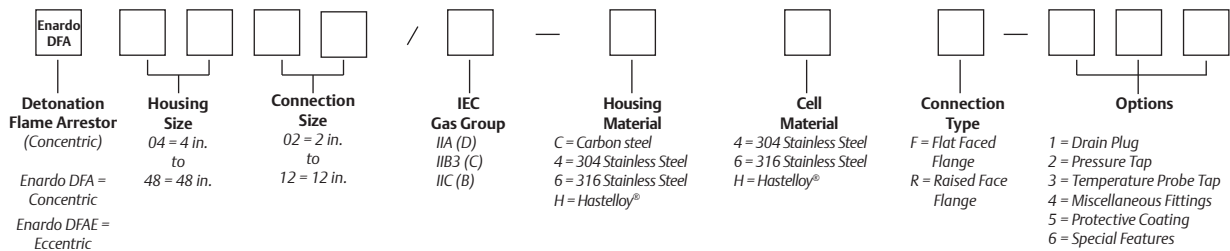

Example:



Indicates a 6 in. Concentric Enardo DFA with a 12 in. Carbon steel housing, ANSI 150 lb raised faced flange connection and a 304 Stainless steel IEC Group "D" flame cell element. It also has an options of drain plugs, pressure taps and standard temperature probe connections.

Hastelloy® is a mark owned by Haynes International, Inc.

Standard Flame Arrestor Selection Criteria

Including US Coast Guard and ATEX/US Coast Guard Certified Detonation Arrestors

PARAMETERS	END-OF-LINE FVFA AND VSFA	IN-LINE (STANDARD) ENARDO™ 7 SERIES, HP AND IL	IN-LINE HP DEFLAGRATION ENARDO 8 SERIES	DETONATION ARRESTOR DFA
NEC Group “D” or IEC Group IIA Gases				
Maximum length of pipe between the arrestor and the ignition source without bends.	(Mounted on end of pipe)	20 ft / 6 m	60 ft / 18 m	Unlimited
Maximum length of pipe between the arrestor and ignition source with 1 to 90° bend.	(Mounted on end of pipe)	20 ft / 6 m	60 ft / 18 m	Unlimited
Maximum length of pipe between the arrestor and the ignition source with multiple bends.	(Mounted on end of pipe)	Not Recommended with Multiple Bends	Not Recommended with Multiple Bends	Unlimited
Flame Stabilization at stoichiometric mixture and ambient temperature not to exceed at 140°F / 60°C. ⁽¹⁾	5 minutes	5 minutes 30 minutes (Factory Mutual Approved units)	15 minutes	2 hours (concentric only)
Operating Pressure	Atmospheric	15.4 psia / 106 kPa	19.7 psia / 134 kPa	Concentric: 3 to 12 in. (22.7 psia) / 50 to 300 mm (157 kPa) Concentric: 2 and 14 to 20 in. (20.7 psia) / 350 to 500 mm (143 kPa)
NEC Group “C” or IEC Group IIB3 Gases				
Maximum length of pipe between the arrestor and the ignition source without bends.	(Mounted on end of pipe)	6 ft / 2 m (open ended pipe)	35 ft / 10.6 m	Unlimited
Maximum length of pipe between the arrestor and ignition source with 1 to 90° bend.	(Mounted on end of pipe)	6 ft / 2 m (open ended pipe)	35 ft / 10.6 m	Unlimited
Maximum length of pipe between the arrestor and the ignition source with multiple bends.	(Mounted on end of pipe)	Not Recommended with Multiple Bends	Not Recommended with Multiple Bends	Unlimited
Flame Stabilization at stoichiometric mixture and ambient temperature not to exceed at 140°F / 60°C. ⁽¹⁾	5 minutes (minimum)	5 minutes (minimum)	15 minutes	15 minutes
Operating Pressure	Atmospheric	15.4 psia / 106 kPa	16.7 psia / 115 kPa	Concentric: 2 to 20 in. (20.7 psia) / 50 to 500 mm (143 kPa) Eccentric: 3 to 20 in. (18.7 psia) / 75 to 500 mm (129 kPa)
NEC Group “B” or IEC Group IIC Gases (Except Acetylene)				
Maximum length of pipe between the arrestor and the ignition source without bends.	(Mounted on end of pipe)	4 ft / 1.2 m (open ended pipe)	15 ft / 4.5 m	Unlimited
Maximum length of pipe between the arrestor and ignition source with 1 to 90° bend.	(Mounted on end of pipe)	Not Recommended with a Bend	15 ft / 4.5 m	Unlimited
Maximum length of pipe between the arrestor and the ignition source with multiple bends.	(Mounted on end of pipe)	Not Recommended with Multiple Bends	Not Recommended with Multiple Bends	Unlimited
Flame Stabilization at stoichiometric mixture and ambient temperature not to exceed at 140°F / 60°C. ⁽¹⁾	2 minutes	2 minutes	15 minutes	15 minutes
Operating Pressure	Atmospheric	15.4 psia / 106 kPa	16.7 psia / 115 kPa	Concentric: 2 to 6 in. (17.7 psia) / 50 to 150 mm (122 kPa)
1. Unlimited burning should not be allowed in any flame arrestor regardless of its burn time rating. We recommend the use of flame sensors, along with an appropriate means of extinguishing the fire, in any situation where a stabilized burn may occur.				

ATEX Certified Flame Arrestor Selection Criteria

See Previous Page for Information on ATEX/US Coast Guard Detonation Arrestor Selection Criteria

PARAMETERS	END-OF-LINE FVFA	IN-LINE (STANDARD) ENARDO™ 7 SERIES, HP AND IL	DETONATION ARRESTOR DFA
IEC Group IIA Gases or NEC Group “D”			
Maximum length of pipe between the arrestor and the ignition source.	(Mounted on end of pipe)	2 in. to 6.5 ft / 50 mm to 2 m 3 in. to 7.5 ft / 75 mm to 2.3 m 4 in. to 10 ft / 100 mm to 3 m 6 in. to 13.1 ft / 150 mm to 4 m 8 in. to 13.3 ft / 200 mm to 4 m 10 in. to 16.6 ft / 250 mm to 5 m 12 in. to 19.7 ft / 300 mm to 6 m	2 to 12 in. / 50 to 300 mm Unrestricted (Designed for Unstable Detonations)
Flame Stabilization at stoichiometric mixture and ambient temperature not to exceed at 140°F / 60°C.	Short Time Burn Rating	Short Time Burn Rating	Short Time Burn Rating
Operating Pressure	Atmospheric	15.95 psia / 110 kPa	2 to 6 in. (17.7 psia) / 50 to 150 mm (122 kPa) 8 to 12 in. (16.9 psia) / 200 to 300 mm (116.5 kPa)
IEC Group IIB3 Gases or NEC Group “C”			
Maximum length of pipe between the arrestor and the ignition source.	(Mounted on end of pipe)	2 in. to 8.3 ft / 50 mm to 2.5 m 3 in. to 12.5 ft / 75 mm to 3.8 m 4 in. to 16.6 ft / 100 mm to 5 m 6 in. to 25 ft / 150 mm to 7.6 m 8 in. to 33.3 ft / 200 mm to 10.16 m 10 in. to 39.3 ft / 250 mm to 12 m 12 in. to 39.4 ft / 300 mm to 12 m	2 to 12 in. / 50 to 300 mm Unrestricted (Designed for Unstable Detonations)
Flame Stabilization at stoichiometric mixture and ambient temperature not to exceed at 140°F / 60°C.	Short Time Burn Rating	Short Time Burn Rating	Short Time Burn Rating
Operating Pressure	Atmospheric	15.95 psia / 110 kPa	17.2 psia / 118.3 kPa

Flame Arrestor Certifications

Flame and Detonation Arrestor

Table 1. Available Approvals for Enardo™ 7 Series Deflagration Flame Arrestors⁽¹⁾

MODEL	GROUP IIA (D)		GROUP IIB3 (C)
	ATEX ISO 16852	Factory Mutual	ATEX ISO 16852
Enardo 70402	X	X	X
Enardo 70602	X		X
Enardo 70603	X	X	X
Enardo 70803	X		X
Enardo 70804	X	X	X
Enardo 71204	X		X
Enardo 71206	X	X	X
Enardo 71606	X		X
Enardo 71608	X	X	X
Enardo 72008	X		X
Enardo 72010	X	X	X
Enardo 72410	X		X
Enardo 72412	X	X	X

Table 2. Available Approvals for Free Vent Flame Arrestors (FVFA)⁽¹⁾

MODEL	GROUP IIA (D)	GROUP IIB3 (C)
	ATEX ISO 16852	ATEX ISO 16852
Enardo 402	X	X
Enardo 602	X	X
Enardo 603	X	X
Enardo 803	X	X
Enardo 804	X	X
Enardo 1204	X	X
Enardo 1206	X	X
Enardo 1606	X	X
Enardo 1608	X	X
Enardo 2008	X	X
Enardo 2010	X	X
Enardo 2410	X	X
Enardo 2412	X	X

1. Applicable approvals must be specified prior to manufacture and will be indicated on the product nameplate.

Flame Arrestor Certifications

Flame and Detonation Arrestor

Table 3. Available Approvals for Detonation Flame Arrestors (DFA)⁽¹⁾ - Group IIA (D)

MODEL	TYPE OF DETONATION	ATEX WITH SHORT TIME BURN RATING	U.S. COAST GUARD AND ATEX/U.S. COAST GUARD WITH ENDURANCE BURN RATING ⁽²⁾
Enardo™ DFA-402	Unstable	X	
Enardo DFA-602	Unstable	X	X ⁽³⁾
Enardo DFA-603	Unstable	X	
Enardo DFA-803	Unstable	X	X
Enardo DFA-804	Unstable	X	
Enardo DFA-1004	Unstable		X
Enardo DFA-1204	Unstable	X	X
Enardo DFA-1206	Unstable	X	X
Enardo DFA-1608	Unstable	X	X
Enardo DFA-2010	Unstable	X	X
Enardo DFA-2412	Unstable	X	X
Enardo DFA-2814	Unstable		X
Enardo DFA-3016	Unstable		X
Enardo DFA-3418	Unstable		X
Enardo DFA-3620	Unstable		X

Table 4. Available Approvals for Detonation Flame Arrestors (DFA)⁽¹⁾ - Group IIB3 (C)

MODEL	TYPE OF DETONATION	ATEX WITH SHORT TIME BURN RATING	U.S. COAST GUARD AND ATEX/U.S. COAST GUARD WITH SHORT TIME BURN RATING
Enardo DFA-402	Unstable	X	
Enardo DFA-602	Unstable	X	X
Enardo DFA-603	Unstable	X	
Enardo DFA-803	Unstable	X	X
Enardo DFA-804	Unstable	X	
Enardo DFA-1004	Unstable		X
Enardo DFA-1204	Unstable	X	X
Enardo DFA-1206	Unstable	X	X
Enardo DFA-1608	Unstable	X	X
Enardo DFA-2010	Unstable	X	X
Enardo DFA-2412	Unstable	X	X
Enardo DFA-2814	Unstable		X
Enardo DFA-3016	Unstable		X
Enardo DFA-3418	Unstable		X
Enardo DFA-3620	Unstable		X

1. Applicable approvals must be specified prior to manufacture and will be indicated on the product nameplate.
2. Endurance burn rating applicable only to concentric configuration.
3. Short time burn rating only for both concentric and eccentric configurations of this model.

Flame Arrestor Design and Application Data Sheet

Flame and Detonation Arrestors

Customer _____
Contact _____
Address _____

Project Reference _____

Date _____
Telephone _____
Fax _____
Email _____

Application Data

Flow Rate (Normal/Max) _____ / _____
Temperature Rate (Normal/Max) _____ / _____ Pressure (Normal/Max) _____ / _____
Gas/Vapor Composition _____ (See next page for additional space)
NEC Gas Group _____ IEC Gas Group _____ MESH _____ mm
(If Gas Group is unknown please provide gas stream composition on next page)
Maximum Allowable Pressure Drop _____
Distance to be Installed from Potential Ignition Source _____ Any Bends? _____ How many? _____
Is Continuous Burning Possible on the FA Element? Yes No

Design Data

End of Line Flame Arrestor (Free Vent) High Pressure Deflagration Flame Arrestor
 Inline Deflagration Flame Arrestor Detonation Flame Arrestor⁽¹⁾

Installation: Horizontal _____ Vertical _____ Other _____
Pipe Size: _____ Flange Pressure Rating: ANSI 150# R.F. (standard)
 DIN
 JIS
 Other _____

Materials:

Housing and Element Housing _____ Flame Cell _____

Options:

Drain Plug _____ (3/4 in. NPT **standard**)
 Temperature Probe Fitting _____ (3/4 in. NPT **standard**)
 Pressure Tap _____ (3/4 in. NPT **standard**)
 Coating/Special Paint _____
 Other Options _____

Additional Information: _____

1. All Detonation Arrestors are designed for unstable detonation and can be placed at any point in the system.

Pressure Vacuum Relief Valves



Pressure Vacuum Relief Valve Design and Application Data Sheet

Pressure Vacuum Relief Valve

Customer _____

Contact _____

Address _____

Project Reference _____

Date _____

Telephone _____

Fax _____

Email _____

Application Data

Tank Capacity _____ Tank Dimension (Diameter/Length) _____/_____

Tank Design Pressure/Vacuum (MAWP/MAWV) _____/_____

Fluid Flash Point Above 100°F / 37.8°C Below 100°F / 37.8°C

Maximum Filling/Emptying Rate _____/_____

Tank Blanketing System Yes No

Blanket System Maximum Flow _____ Flow Rate (Normal/Maximum) _____/_____

Temperature (Normal/Maximum) _____/_____ Pressure (Normal/Maximum) _____/_____

Pressure Setting (in. w.c. / oz./sq. in. / psi) _____/_____ Vacuum Setting (in. w.c. / oz./sq. in. / psi) _____/_____

Maximum Back Pressure _____

or

Calculate Total Outbreathing _____ Calculate Total Inbreathing _____

Relief Valve in combination with Flame Arrestor Detonation Flame Arrestor

Design Data

Pipe-Away Pressure/Vacuum Relief Valve

Pipe-Away Pressure Only Relief Valve

Pipe-Away Vacuum Only Relief Valve

Vent to Atmosphere Pressure/Vacuum Relief Valve

Vent to Atmosphere Pressure Only Relief Valve

Vent to Atmosphere Vacuum Only Relief Valve

Installation: Top Mounted Side Mounted

Pipe Size: Inlet _____ in. Outlet _____ in.

Flange Pressure Rating: ANSI 150# R.F. (**standard**) DIN JIS Other _____

Materials:

Housing Assembly _____ Seat/Pallet _____

Weight Material _____ Pallet Seal _____

Options:

Coating/Special Paint _____

Special Gasketing _____

Other Options _____

Additional Information: _____



Introduction

Enardo™ 800-SO in-line vent valves prevent the escape of light ends of crude by maintaining pressure in the storage tank. The in-line vent valve is installed directly into the vent line exhaust. The Enardo 800-SO has both pressure and vacuum relief capability whereas the Enardo 800-PSO has only pressure relief capability.

The pressure vacuum vent valve opens when the system pressure or vacuum exceeds the set pressure of the valve. When over pressure occurs, the weighted pallet lifts, breaking the seal between the seat and pallet, allowing vapors to pass through the valve orifice and relieving the pressure or vacuum buildup. The valve closes once the tank pressure goes below the setpoint.

Available Vent Sizes

2 to 4 in. / 50 to 100 mm

Vent Setting Range

Pressure

1.0 to 16.0 oz./sq. in. / 4.3 to 69.0 mbar
(0.5 oz./sq. in. or 2.2 mbar increments)

Vacuum

0.4 oz./sq. in. / 1.7 mbar

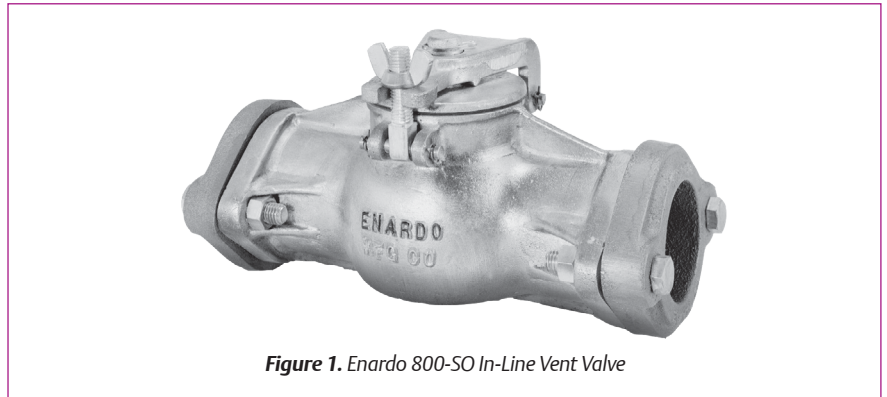

Figure 1. Enardo 800-SO In-Line Vent Valve

Construction Materials

Housing

Cast Aluminum

Seat/Pallet

Polyphenylene Sulfide (PPS)

Pallet Seal

Buna-N or Viton®

Hardware

Zinc-plated carbon steel

Weight

Lead

Gasket

Buna-N or Viton®

Additional Technical Data

For more technical information, contact your local Sales Office or log on to:

www.enardo.com

Features

- All internal working parts are made from a Polyphenylene Sulfide (PPS) plastic material for superior corrosion resistance which resists freezing and sticking with operating ranges from -50 to 500°F
- Multiple setting options by adding additional pressure weights
- Viton® gaskets for “Sour Gas” and corrosive service applications
- Non-Corrosive coating option for extremely harsh environments
- Certified flow capacities in accordance with API

Viton® is a mark owned by E. I. du Pont de Nemours and Company.

Enardo 800-SO

In-Line Vent Valve

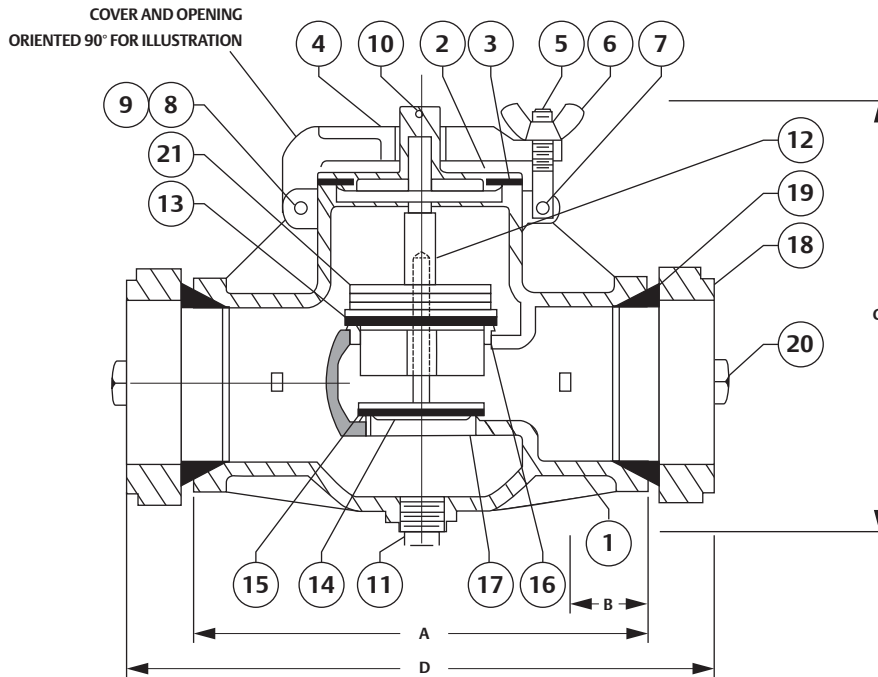

Figure 2. Enardo™ 800-SO In-Line Vent Valve Dimensions

Table 1. Enardo 800-SO Dimensions

MODEL	SIZE		A		B		C (HEIGHT)		D (LENGTH)		APPROXIMATE WEIGHT	
	In.	mm	In.	mm	In.	mm	In.	mm	In.	mm	Lbs	kg
Enardo 820-SO	2	50	9	220	1-3/4	44	8-1/2	216	10-3/4	273	11	5
Enardo 830-SO	3	80	10	260	1-7/8	48	10-1/2	267	13-1/8	333	16	7
Enardo 840-SO	4	100	12	300	2-1/8	54	12	305	14-3/4	375	25	11

Table 2. Enardo 800-SO In-Line Vent Valve

KEY	PART NAME	PART NUMBER		
		2 In.	3 In.	4 In.
1	Valve Body	A2VSO1	A3VSO1	A4VSO1
2	Cap	2V3A	3V3A	4V3A
3	Cap Gasket	2V3G	3V3G	4V3G
4	Yoke	2V39	3V39	4V39
5	Eyebolt	S31B	S31B	S31B
6	Wing Nut	NPN	NPN	NPN
7	Eyebolt Pin	5-C	5-C	5-C
8	Cap Hinge Pin	5-N	5-B	5-B
9	Hinge Pin Clip	HPC-148	HPC-148	HPC-148
10	Cotter Key	NPN	NPN	NPN
11	Pipe Plug	NPN	NPN	NPN
12	Pressure Disc	2P4P	3P4P	4P4P
13	Pressure Gasket	2P4G	3P4G	4P4G
14	Vacuum Disc	2V4P	3V4P	4V4P
15	Vacuum Gasket	2V4G	3V4G	4V4G
16	Pressure Seat	2P4P-3	3P4P-3	4P4P-3
17	Vacuum Seat	2V4P-3	3V4P-3	4V4P-3
18	Slip-on Flange	0-2	0-3	0-4
19	Flange Gasket	S-2-G	S-3-G	S-4-G
20	Bolt and Nut	1/2 x 13 x 2-1/2	1/2 x 13 x 3	1/2 x 13 x 3
21	Pressure Weight	2-PW-1/2	2-PW-1	3-PW-1

Enardo 800-PSO

In-Line Vent Valve

Introduction

Enardo™ 800-PSO pressure only vent valves are designed to relieve pressure only through the vent line. By omitting the vacuum side of the valve they eliminate the possibility of a two way flow. These are designed the same as the Enardo 800-SO except the vacuum side of the valve is eliminated. All valves are lined and trimmed with plastic where moving parts or surfaces may become fouled by crude gasses or materials.

Available Vent Sizes

2 to 4 in. / 50 to 100 mm

Vent Setting Range

Pressure

1.0 to 16.0 oz./sq. in. / 4.3 to 69.0 mbar
(0.5 oz./sq. in. or 2.2 mbar increments)

Construction Materials

Housing

Cast Aluminum

Seat/Pallet

Polyphenylene Sulfide (PPS)

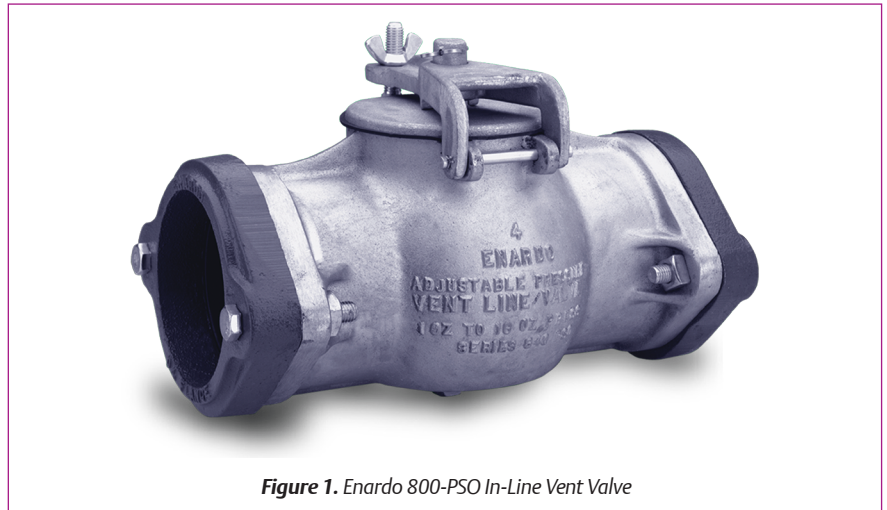

Figure 1. Enardo 800-PSO In-Line Vent Valve

Construction Materials (continued)

Pallet Seal

Buna-N or Viton®

Hardware

Zinc-plated carbon steel

Weight

Lead

Gasket

Buna-N or Viton®

Additional Technical Data

For more technical information, contact your local Sales Office or log on to:

www.enardo.com

Features

- All internal working parts are made from a Polyphenylene Sulfide (PPS) plastic material for superior corrosion resistance which resists freezing and sticking with operating ranges from -50°F to 500°F
- Multiple setting options by adding additional pressure weights
- Viton® gaskets for “Sour Gas” and corrosive service applications
- Non-Corrosive coating option for extremely harsh environments
- Certified flow capacities in accordance with API

Viton® is a mark owned by E. I. du Pont de Nemours and Company.

Enardo 800-PSO

In-Line Vent Valve

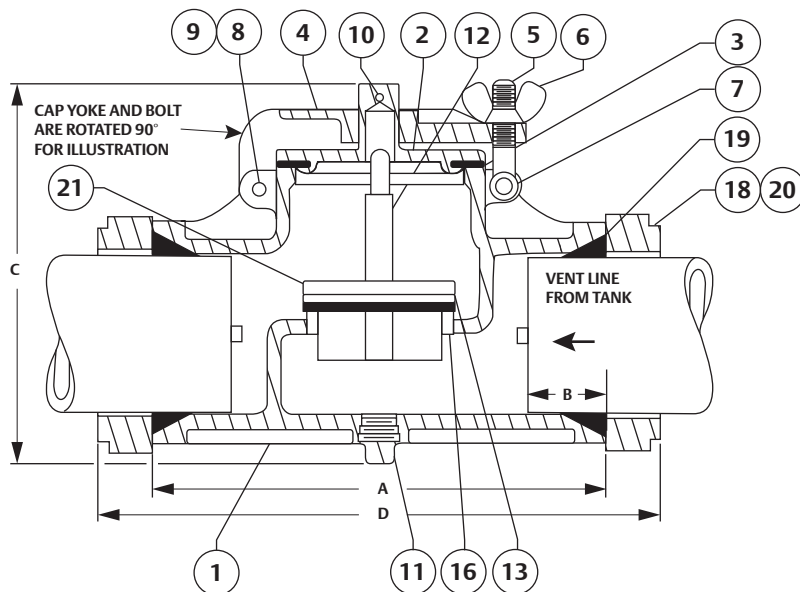

Figure 2. Enardo™ 800-PSO In-Line Vent Valve Dimensions

Table 1. Enardo 800-PSO Dimensions

MODEL	SIZE		A		B		C (HEIGHT)		D (LENGTH)		APPROXIMATE WEIGHT	
	In.	mm	In.	mm	In.	mm	In.	mm	In.	mm	Lbs	kg
Enardo 820-PSO	2	50	9-3/4	247	1-3/4	44	6-9/16	169	11-1/2	292	11	5
Enardo 830-PSO	3	80	10-3/16	259	1-3/4	44	8-3/8	213	12-11/16	322	16	7
Enardo 840-PSO	4	100	12-1/4	311	2-1/4	57	9-3/8	238	14-3/4	375	25	11

Table 2. Enardo 800-PSO In-Line Vent Valve

KEY	PART NAME	PART NUMBER		
		2 In.	3 In.	4 In.
1	Valve Body	A2VSO1	A3VSO1	A4VSO1
2	Cap	2V3A	3V3A	4V3A
3	Cap Gasket	2V3G	3V3G	4V3G
4	Yoke	2V39	3V39	4V39
5	Eyebolt	S31 B	S31 B	S31 B
6	Wing Nut	NPN	NPN	NPN
7	Eyebolt Pin	5-C	5-C	5-C
8	Cap Hinge Pin	5-N	5-B	5-B
9	Hinge Pin Clip	HPC-148	HPC-148	HPC-148
10	Cotter Key	NPN	NPN	NPN
11	Pipe Plug	NPN	NPN	NPN
12	Pressure Disc	2P4P	3P4P	4P4P
13	Pressure Gasket	2P4G	3P4G	4P4G
16	Pressure Seat	2P4P-3	3P4P-3	4P4P-3
18	Slip-on Flange	0-2	0-3	0-4
19	Flange Gasket	S-2-G	S-3-G	S-4-G
20	Bolt and Nut	1/2 x 13 x 2-1/2	1/2 x 13 x 3	1/2 x 13 x 3
21	Pressure Weight	2-PW-1	3-PW-1	4-PW-1

Enardo 900-SO

End-of-Line Stack Vent Valve

Introduction

Enardo™ 900-SO end-of-line vent valves prevent the escape of light ends of crude by maintaining pressure in the storage tank. The end-of-line vent valve is installed directly on the end of the vent line exhaust. The Enardo 900-SO has both pressure and vacuum relief capability.

The pressure/vacuum vent valve opens when the system pressure or vacuum exceeds the set pressure of the valve. When over pressure occurs, the weighted pallet lifts, breaking the seal between the seat and pallet, allowing vapors to pass through the valve orifice and relieving the pressure or vacuum buildup. The valve closes once the tank pressure goes below the setpoint.

Available Sizes

2 to 4 in. / 50 to 100 mm

Vent Setting Range

Pressure

1.0 to 16.0 oz./sq. in. / 4.3 to 69.0 mbar
(0.5 oz./sq. in. or 2.2 mbar increments)

Vacuum

0.4 oz./sq. in / 1.7 mbar

Construction Materials

Housing

Cast Aluminum

Seat/Pallet

Polyphenylene Sulfide (PPS)

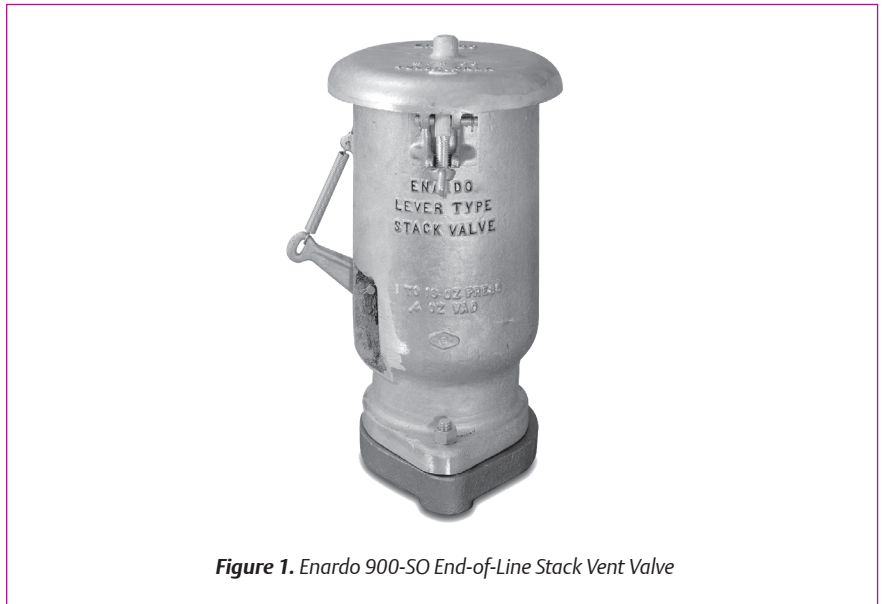

Figure 1. Enardo 900-SO End-of-Line Stack Vent Valve

Construction Materials (continued)

Pallet Seal

Buna-N or Viton®

Hardware

Zinc-plated carbon steel

Weight

Lead

Gasket

Buna-N or Viton®

Additional Technical Data

For more technical information, contact your local Sales Office or log on to:

www.enardo.com

Features

- All internal working parts are made from a Polyphenylene Sulfide (PPS) plastic material for superior corrosion resistance which resists freezing and sticking with operating ranges from -50 to 500°F
- Multiple setting options by adding additional pressure weights
- Viton® gaskets for “Sour Gas” and corrosive service applications
- Non-corrosive coating option for extremely harsh environments
- Certified flow capacities in accordance with API

Viton® is a mark owned by E. I. du Pont de Nemours and Company.

Enardo 900-SO

End-of-Line Stack Vent Valve

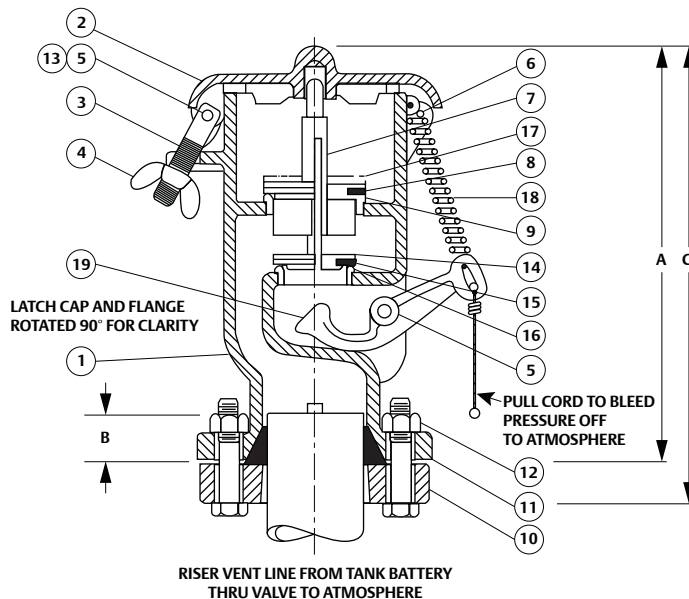

Figure 2. Enardo™ 900-SO Dimensions

Table 1. Enardo 900-SO Dimensions

MODEL	SIZE		A		B		C (HEIGHT)		APPROXIMATE WEIGHT ⁽¹⁾	
	In.	mm	In.	mm	In.	mm	In.	mm	Lbs	kg
Enardo 920-SO	2	50	10	260	1-1/8	29	11-1/4	286	11	5
Enardo 930-SO	3	80	12	300	1-3/4	44	13-1/4	337	16	7
Enardo 940-SO	4	100	14	360	1-7/8	48	15-1/4	387	25	11

1. Unit weights indicate Net Weight of valve in pounds at standard set pressure (1.0 oz./sq. in. pressure - 0.4 oz./sq. in. vacuum), does not include shipping crate or box. Add 20% for gross shipping weight (Domestic Only).

Table 2. Enardo 900-SO End-of-Line Vent Valve

KEY	PART NAME	2 IN.	3 IN.	4 IN.
1	Valve Body	A2S01	A3S01	A4S01
2	Cap	2-S-3	3-S-3	4-S-3
3	Eyebolt	S31B	S31B	S31B
4	Wing Nut	NPN	NPN	NPN
5	Hinge Pin	5-C	5-C	5-C
6	Cap Hinge Pin	5-N	5-B	5-DD
7	Pressure Disk	2P4P	3P4P	4P4P
8	Pressure Gasket	2P4G	3P4G	4P4G
9	Pressure Seat	2P4P-3	3P4P-3	4P4P-3
10	Slip-On Flange	0-2	0-3	0-4
11	Flange Gasket	S-2-G	S-3-G	S-4-G
12	Bolt and Nut	1/2 x 13 x 2-1/2	1/2 x 13 x 3	1/2 x 13 x 3
13	Hinge Pin Clip	HPC-148	HPC-148	HPC-148
14	Vacuum Disk	2V4P	3V4P	4V4P
15	Vacuum Gasket	2V4G	3V4G	4V4G
16	Vacuum Seat	2V4P-3	3V4P-3	4V4P-3
17	Pressure Weight	2-PW-1/2	2-PW-1	3-PW-1
18	Lever Spring	900-33	900-33	900-33
19	Test Lever	2-S-8	3-S-8	4-S-8

Introduction

Enardo™ ES-805-SO In-Line Vent Valves represent the latest development in high-performance, tight-sealing tank venting products and complement the industry-leading Enardo ES-665 Series Thief Hatch product line. With a leakage rate of no more than 0.1 SCFH at 90% of set point, the Enardo ES-805-SO offers unparalleled vent valve performance.

Enardo ES-805-SO In-Line Vent Valves are designed to prevent the escape of light ends of crude by maintaining pressure in the storage tank. The in-line vent valve is installed directly into the vent line exhaust. The Enardo ES-805-SO has both pressure and vacuum relief capability whereas the Enardo ES-805-PSO has only pressure relief capacity.

The pressure vacuum vent valve opens when the system pressure or vacuum exceeds the set pressure of the valve. When over pressure occurs, the pallet lifts, breaking the seal between the seat and pallet, allowing vapors to pass through the valve orifice and relieving the pressure or vacuum buildup. The valve closes once the tank pressure goes below the set pressure.

Available Sizes

2 through 4 in. / 50 through 100 mm

Vent Setting Range

Pressure

1.0 to 16.0 oz./sq. in. / 4.3 to 6.90 mbar
(0.5 oz./sq. in. / 2 mbar increments)

Vacuum

0.4 oz./sq. in. / 1.7 mbar

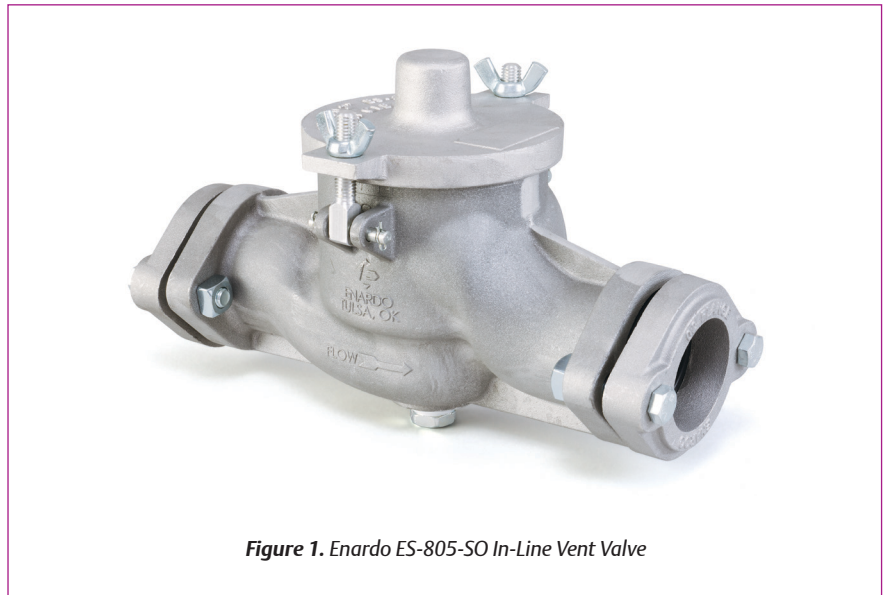

Figure 1. Enardo ES-805-SO In-Line Vent Valve

Construction Materials

Housing

Cast Aluminum

Pallet

Aluminum

Pressure Seal

Nitrile (NBR) or Fluorocarbon (FKM)

Hardware

Zinc-plated carbon steel

Weight

Zinc-plated carbon steel
(to 12 oz./sq. in. / 51.7 mbar) Lead

Body Gasketing

Nitrile (NBR) or Fluorocarbon (FKM)

Additional Technical Data

For more technical information, contact your local Sales Office or log on to:

www.enardo.com

Features

- Multiple setting options by adding additional pressure weights
- Fluorocarbon (FKM) gaskets for “Sour Gas” and corrosive service applications
- Leakage rate of no greater than 0.1 SCFH at 90% of setpoint
- Non-corrosive coating option for extremely harsh environments
- Certified flow capacities in accordance with API

Enardo ES-805-SO

In-Line Vent Valve

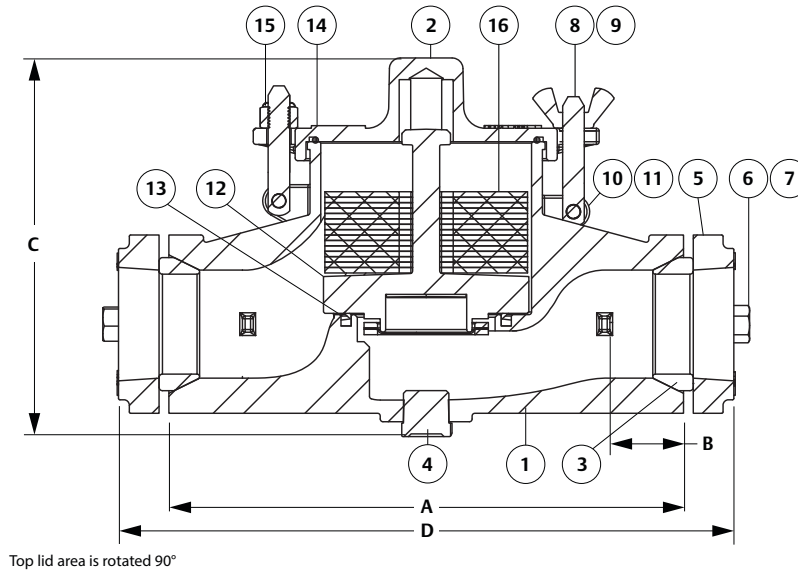

Figure 2. Enardo™ ES-805-SO Dimensions

Table 1. Enardo ES-805-SO Dimensions

MODEL	SIZE		A		B		C (HEIGHT)		D (LENGTH)		APPROXIMATE WEIGHT	
	In.	mm	In.	mm	In.	mm	In.	mm	In.	mm	Lb	kg
Enardo ES-825-SO	2	50	11-7/8	302	1-3/4	44.5	8-3/4	222	14-1/4	362	12	5
Enardo ES-835-SO	3	80	12	305	1-3/4	44.5	10-1/4	260	15-1/4	387	17	8
Enardo ES-845-SO	4	100	14-1/2	368	1-3/4	44.5	11-5/8	295	17-1/4	438	23	10

Table 2. Enardo ES-805-SO In-line Vent Valve

KEY	PART NAME	PART NUMBER		
		2 In. / 50 mm	3 In. / 80 mm	4 In. / 100 mm
1	Valve Body	3514261	3514297	3514321
2	Lid	3514264	3514300	3514335
3	Flange Gasket	3505501	3505502	3505503
4	Pipe Plug	2023802	2023802	2023802
5	Slip-on Flange	3508901	3508902	3508903
6	Hex Bolt	2021203	2021200	2021200
7	Square Nut	2021901	2021901	2021901
8	Eyebolt	3505601	3505601	3505601
9	Wing Nut	2001002	2001002	2001002
10	Latch Pin	4505103	4505103	4505103
11	Latch Clip (HPC-148)	2027100	2027100	2027100
12	Pallet Assembly, Nitrile (NBR)	ERAA43150A0	ERAA43150A2	ERAA43150A4
12	Pallet Assembly, Fluorocarbon (FKM)	ERAA43150A1	ERAA43150A3	ERAA43150A5
13	V-ring Seal, Nitrile (NBR)	3514286	3514316	3514323
13	V-ring Seal, Fluorocarbon (FKM)	3514313	3514317	3514324
14	Lid O-ring, Nitrile (NBR)	3514285	3514318	3514365
14	Lid O-ring, Fluorocarbon (FKM)	3514314	3514319	3514372
15	Nylock Nut	1/2 - 13	1/2 - 13	1/2 - 13
16	Pressure Weight(s)	As required	As required	As required

Introduction

Enardo™ ES-805-PSO In-Line Vent Valves represent the latest development in high-performance, tight-sealing tank venting products and complement the industry-leading Enardo ES-665 Series Thief Hatch product line. With a leakage rate of no more than 0.1 SCFH at 90% of setpoint, the Enardo ES-805-PSO offers unparalleled vent valve performance and a substantial increase in flow as compared to non-ES models.

Enardo ES-805-PSO Pressure Only vent valves are designed to relieve pressure only through the vent line. By omitting the vacuum side of the valve they eliminate the possibility of a two-way flow. These are designed the same as the “SO” pressure/vacuum series except they eliminate the vacuum side of the valve.

Available Sizes

2 to 4 in. / 50 to 100 mm

Vent Setting Range

Pressure

1.0 to 16.0 oz./sq. in. / 4.3 to 6.90 mbar
(0.5 oz./sq. in. / 2 mbar increments)

Construction Materials

Housing

Cast Aluminum

Pallet

Aluminum

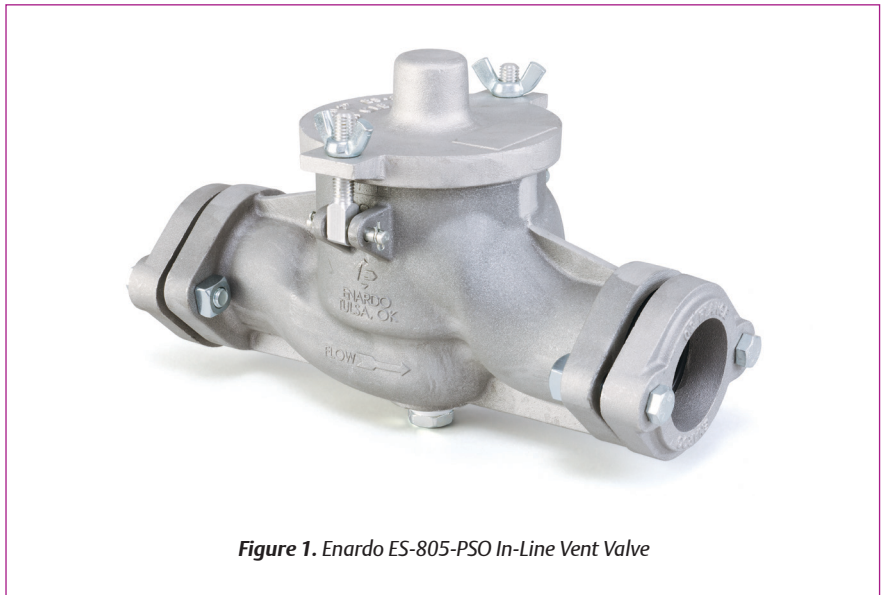

Figure 1. Enardo ES-805-PSO In-Line Vent Valve

Construction Materials (continued)

Pressure Seal

Nitrile (NBR) or Fluorocarbon (FKM)

Hardware

Zinc-plated carbon steel

Weight

Zinc-plated carbon steel
(to 12 oz. /sq. in.) Lead

Body Gasketing

Nitrile (NBR) or Fluorocarbon (FKM)

Additional Technical Data

Scan or Click the QR code for more information on this product.

www.Enardo.com



09/23

Features

- Multiple setting options by adding additional pressure weights
- Fluorocarbon (FKM) gaskets for “Sour Gas” and corrosive service applications
- Leakage rate of no greater than 0.1 SCFH at 90% of setpoint
- Non-Corrosive coating option for extremely harsh environments
- Certified flow capacities in accordance with API

Enardo ES-805-PSO

In-Line Vent Valve

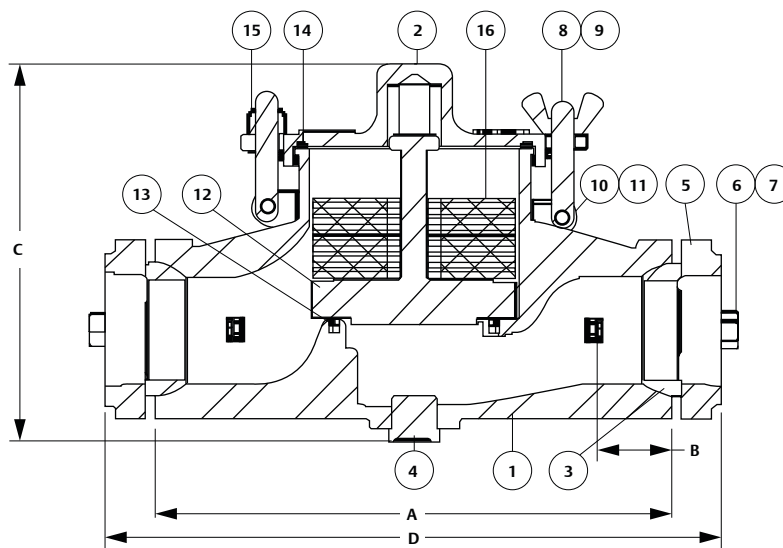

Top lid area is rotated 90°.

Figure 2. Enardo™ ES-805-PSO In-Line Vent Valve Dimensions

Table 1. Enardo ES-805-PSO In-Line Vent Valve Dimensions

MODEL	SIZE		A		B		C, HEIGHT		D, LENGTH		APPROXIMATE WEIGHT	
	In.	mm	In.	mm	In.	mm	In.	mm	In.	mm	lb	kg
Enardo ES-825-PSO	2	50	11-7/8	302	1-3/4	44.5	8-3/4	222	14-1/4	362	12	5
Enardo ES-835-PSO	3	80	12	305	1-3/4	44.5	10-1/4	260	15-1/4	387	17	8
Enardo ES-845-PSO	4	100	14-1/2	368	1-3/4	44.5	11-5/8	295	17-1/4	438	23	10

Table 2. Enardo ES-805-PSO In-line Vent Valve

KEY	PART NAME	2 In.	3 In.	4 In.
1	Valve Body	3514261	3514297	3514321
2	Lid	3514264	3514300	3514335
3	Flange Gasket	3505501	3505502	3505503
4	Pipe Plug	2023802	2023802	2023802
5	Slip-on Flange	3508901	3508902	3508903
6	Hex Bolt	2021203	2021200	2021200
7	Square Nut	2021901	2021901	2021901
8	Eyebolt	3505601	3505601	3505601
9	Wing Nut	2001002	2001002	2001002
10	Latch Pin	4505103	4505103	4505103
11	Latch Clip (HPC-148)	2027100	2027100	2027100
12	Pallet	3514268	3514294	3514333
13	V-ring Seal, Nitrile (NBR)	3514286	3514316	3514323
13	V-ring Seal, Fluorocarbon (FKM)	3514313	3514317	3514324
14	Lid O-ring, Nitrile (NBR)	3514285	3514318	3514365
14	Lid O-ring, Fluorocarbon (FKM)	3514314	3514319	3514372
15	Nylock Nut	1/2-13	1/2-13	1/2-13
16	Pressure Weight(s)	As required	As required	As required

Introduction

Enardo™ ES-905-SO end-of-line vent valves represent the latest development in high-performance, tight-sealing tank venting products, and complement the industry-leading Enardo ES-665 Series thief hatch product line. With a leakage rate of no more than 0.1 SCFH at 90% of set point, the Enardo ES-905-SO offers unparalleled vent valve performance.

Enardo ES-905-SO End-of-Line Vent Valve is designed to prevent the escape of light ends of crude by maintaining pressure in the storage tank. The end-of-line vent valve is installed directly on the end of the vent line exhaust. The Enardo ES-905-SO has both pressure and vacuum relief capability.

The pressure vacuum vent valve opens when the system pressure or vacuum exceeds the set pressure of the valve. When over pressure occurs, the pallet lifts, breaking the seal between the seat and pallet, allowing vapors to pass through the valve orifice and relieving the pressure or vacuum buildup. The valve closes once the tank pressure goes below the setting point.

Available Sizes

2 to 4 in. / 50 to 100 mm

Vent Setting Range

Pressure

1.0 to 16.0 oz./sq. in. / 4.3 to 6.90 mbar
(0.5 oz./sq. in. / 2 mbar increments)

Vacuum

0.4 oz./sq. in. / 1.7 mbar



Figure 1. Enardo ES-905-SO End-of-Line Stack Vent Valve

Construction Materials

Housing

Cast Aluminum

Pallet

Aluminum

Pressure Seal

Nitrile (NBR) or Fluorocarbon (FKM)

Hardware

Zinc-plated carbon steel

Weight

Zinc-plated carbon steel
(to 12 oz./sq. in.) Lead

Body Gasketing

Nitrile (NBR) or Fluorocarbon (FKM)

Additional Technical Data

For more technical information, contact your local Sales Office or log on to:

www.enardo.com

Features

- Multiple setting options by adding additional pressure weights
- Fluorocarbon (FKM) gaskets for “Sour Gas” and corrosive service applications
- Non-Corrosive coating option for extremely harsh environments
- Leakage rate of no greater than 0.1 SCFH at 90% of setpoint
- Certified flow capacities in accordance with API
- Tight sealing
- Superior flow

Enardo ES-905-SO

End-of-Line Stack Vent Valve

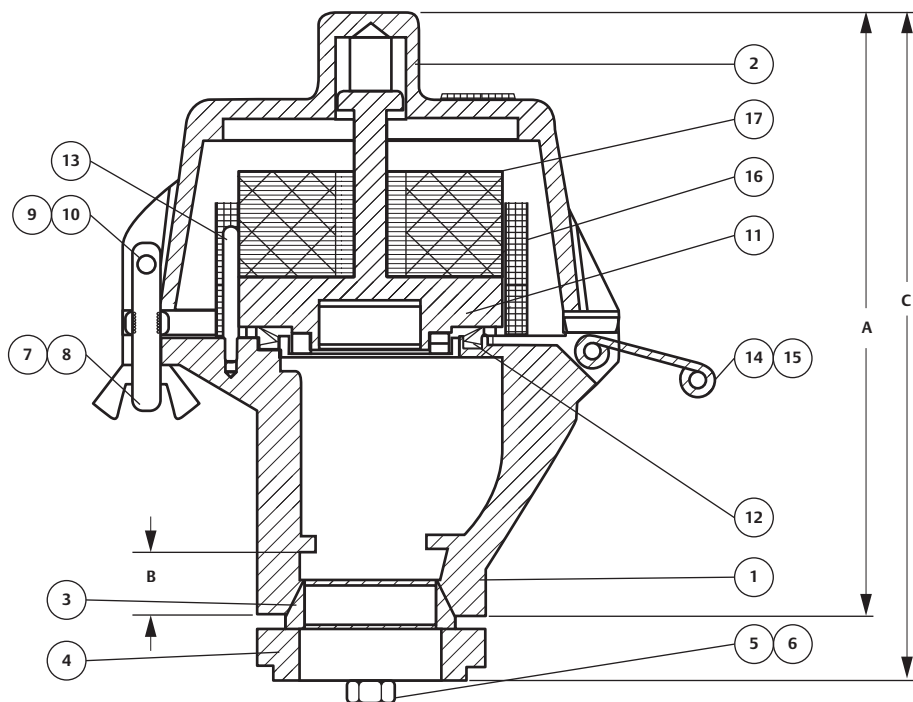

Figure 2. Enardo™ ES-905-SO Dimensions

Table 1. Enardo ES-905-SO Dimensions

MODEL	SIZE		A		B		C (HEIGHT)		APPROXIMATE WEIGHT ⁽¹⁾	
	In.	mm	In.	mm	In.	mm	In.	mm	Lb	kg
Enardo ES-925-SO	2	50	10-7/8	276	1-1/4	31.8	12-1/8	308	11	5
Enardo ES-935-SO	3	80	13	330	1-1/4	31.8	14-5/8	371	15	7
Enardo ES-945-SO	4	100	14-1/4	362	1-1/4	31.8	15-1/2	394	19	9

1. Unit weights indicate Net Weight of valve in pounds at standard set pressure (1.0 oz./sq. in. pressure - 0.4 oz./sq. in. vacuum), does not include shipping crate or box. Add 20% for gross shipping weight (Domestic Only).

Table 2. Enardo ES-905-SO In-line Vent Valve

KEY	PART NAME	PART NUMBER		
		2 In.	3 In.	4 In.
1	Valve Body	3514326	3514337	3514341
2	Hood	3514329	3514339	3514343
3	Flange Gasket	3505501	3505502	3505503
4	Slip-on Flange	3508901	3508902	3508903
5	Hex Bolt	2021203	2021200	2021200
6	Square Nut	2021901	2021901	2021901
7	Eyebolt	3505601	3505601	3505601
8	Wing Nut	2001002	2001002	2001002
9	Latch Pin	4505103	4505103	4505103
10	Latch Clip (HPC-148)	2027100	2027100	2027100
11	Pallet Assembly, Nitrile (NBR)	ERAA43150A0	ERAA43150A2	ERAA43150A4
11	Pallet Assembly, Fluorocarbon (FKM)	ERAA43150A1	ERAA43150A3	ERAA43150A5
12	V-ring Seal, Nitrile (NBR)	3514286	3514316	3514323
12	V-ring Seal, Fluorocarbon (FKM)	3514313	3514317	3514324
13	Guide Rod	3514344	3514345	3514346
14	Lever	3514350	3514350	3514350
15	Lever Spring	3514351	3514351	3514351
16	Screen	3514330	3514347	3514348
17	Pressure Weight(s)	As required	As required	As required

Enardo ES-905-PSO

End-of-Line Stack Vent Valve

Introduction

Enardo™ ES-905-PSO End-of-Line Stack Vent Valves represent the latest development in high-performance, tight sealing tank venting products, and complement the Industry-leading Enardo ES-665 Series Thief Hatch product line. With a leakage rate of no more than 0.1 SCFH at 90% of set point, the Enardo ES-905-PSO offers unparalleled vent valve performance.

Enardo ES-905-PSO End-of-Line Stack Vent Valve is designed to prevent the escape of light ends of crude by maintaining pressure in the storage tank. The end-of-line vent valve is installed directly on the end of the vent line exhaust. The Enardo ES-905-PSO has only pressure relief capability.

The valve opens when the system pressure exceeds the set pressure of the valve. When over pressure occurs, the pallet lifts, breaking the seal between the seat and pallet, allowing vapors to pass through the valve orifice and relieving the pressure buildup. The valve closes once the tank pressure goes below the setting point.

Available Sizes

2 to 4 in. / 50 to 100 mm

Vent Setting Range

Pressure

1.0 to 16.0 oz./sq. in. / 4.3 to 6.90 mbar
(0.5 oz./sq. in. / 2 mbar increments)



Construction Materials

Housing

Cast Aluminum

Pallet

Aluminum

Pressure Seal

Nitrile (NBR) or Fluorocarbon (FKM)

Hardware

Zinc-plated carbon steel

Weight

Zinc-plated carbon steel
(to 12 oz./sq. in.) Lead

Body Gasketing

Nitrile (NBR) or Fluorocarbon (FKM)

Features

- Multiple setting options by adding additional pressure weights
- Fluorocarbon (FKM) gaskets for “Sour Gas” and corrosive service applications
- Non-Corrosive coating option for extremely harsh environments
- Leakage rate of no greater than 0.1 SCFH at 90% of setpoint
- Certified flow capacities in accordance with API
- Tight sealing
- Superior flow

Additional Technical Data

Scan or Click the QR code for more information on this product.

www.Enardo.com



09/23

Enardo ES-905-PSO

End-of-Line Stack Vent Valve

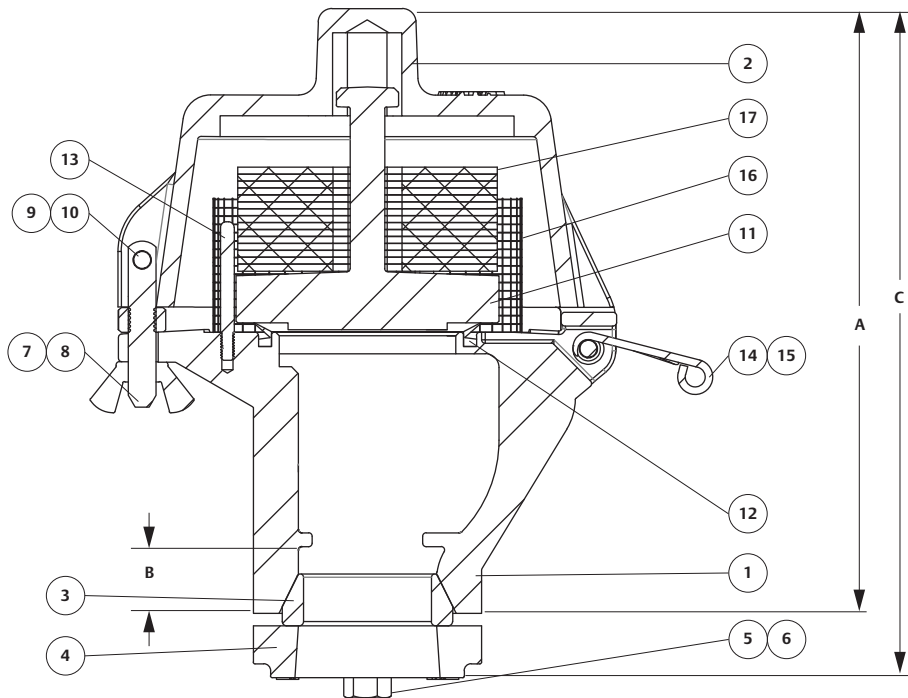

Top lid area is rotated 90°

Figure 2. Enardo™ ES-905-PSO End-of-Line Stack Vent Valve Dimensions

Table 1. Enardo ES-905-PSO End-of-Line Stack Vent Valve Dimensions

MODEL	SIZE		A		B		C, HEIGHT		APPROXIMATE WEIGHT ⁽¹⁾	
	In.	mm	In.	mm	In.	mm	In.	mm	lb	kg
Enardo ES-925-PSO	2	50	10-7/8	276	1-1/4	31.8	12-1/8	308	11	5
Enardo ES-935-PSO	3	80	13	330	1-1/4	31.8	14-5/8	371	15	7
Enardo ES-945-PSO	4	100	14-1/4	362	1-1/4	31.8	15-1/2	394	19	9

1. Unit weights indicate Net Weight of valve in pounds at standard set pressure (1.0 oz./sq. in. pressure - 0.4 oz./sq. in. vacuum), does not include shipping crate or box. Add 20% for gross shipping weight (Domestic Only).

Table 2. Enardo ES-905-PSO End-of-Line Stack Vent Valve Vent Valve

KEY	PART NAME	PART NUMBER		
		2 In.	3 In.	4 In.
1	Valve Body	3514326	3514337	3514341
2	Hood	3514329	3514339	3514343
3	Flange Gasket	3505501	3505502	3505503
4	Slip-on Flange	3508901	3508902	3508903
5	Hex Bolt	2021203	2021200	2021200
6	Square Nut	2021901	2021901	2021901
7	Eyebolt	3505601	3505601	3505601
8	Wing Nut	2001002	2001002	2001002
9	Latch Pin	4505103	4505103	4505103
10	Latch Clip (HPC-148)	2027100	2027100	2027100
11	Pallet	3514268	3514294	3514333
12	V-ring Seal, Nitrile (NBR)	3514286	3514316	3514323
12	V-ring Seal, Fluorocarbon (FKM)	3514313	3514317	3514324
13	Guide Rod	3514344	3514345	3514346
14	Lever	3514350	3514350	3514350
15	Lever Spring	3514351	3514351	3514351
16	Screen	3514330	3514347	3514348
17	Pressure Weight(s)	As required	As required	As required

High Performance Pressure Vacuum Relief Valves, Enardo ES-850 and ES-Enardo 950 Series - *The Ultimate in Tank Protection*

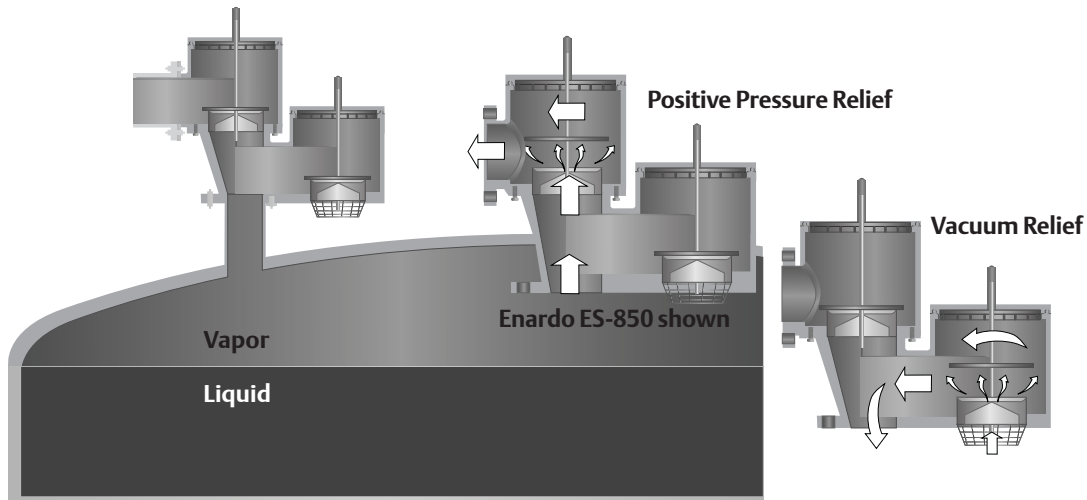

Figure 1. Enardo™ ES-850 Flow Illustration

High performance line of pressure vacuum relief valves, Enardo ES-850 and Enardo ES-950 Series, provides superior protection against positive or vacuum over pressure and prevents air intake, evaporative or blanketing product losses and helps contain odorous, hazardous and potentially explosive vapors with an industry leading leakage rate not to exceed **0.1 SCFH at 90% of setpoint**. This line of pressure and vacuum conservation vents incorporate advanced features developed from leading edge technology. These valves feature improved materials and operational performance.

Advanced Composite Material

One significant innovation featured in this line of valves is the use of a high performance, fiber reinforced, advanced composite, linear thermoplastic polymer called Polyphenylene Sulfide (PPS).

For over two decades Polyphenylene Sulfide (PPS) has replaced conventional materials, e.g., stainless steel, for industrial applications that require superior corrosion resistance and non-sticking and high temperature performance. Polyphenylene Sulfide (PPS) was first utilized in 1980 for the seat and pallet of their pressure vacuum vent line valves due to the superior performance features of Polyphenylene Sulfide (PPS) in high content H₂S applications. Application trials utilizing the valve components in other corrosive atmospheres were similarly successful, bringing unanimous acceptance of Polyphenylene Sulfide (PPS) components, even in hydrochloric acid vapor containment. The success and wide acceptance of this material in almost every application provided

the basis to utilize Polyphenylene Sulfide (PPS) in high performance pressure vacuum relief valve line as an improvement over designs that have not changed in over 40 years.

Polyphenylene Sulfide (PPS) is used for the seat ring and pallet which are the critical operational components of the valve. The pallet and seat are responsible for maintaining the vapor tight seal during normal tank storage or other process system operations. When tank breathing or process system interruptions cause positive or negative pressure buildup, the pallet and seat function together to relieve the pressure. It is critical that the valve components provide a vapor tight seal until relief and open reliably. Polyphenylene Sulfide (PPS) parts provide performance characteristics consistent with reliable valve operation by reducing the opportunity of the parts to stick, freeze or deteriorate.

Enardo ES-850 and ES-950 Series

Pressure Vacuum Relief Valve

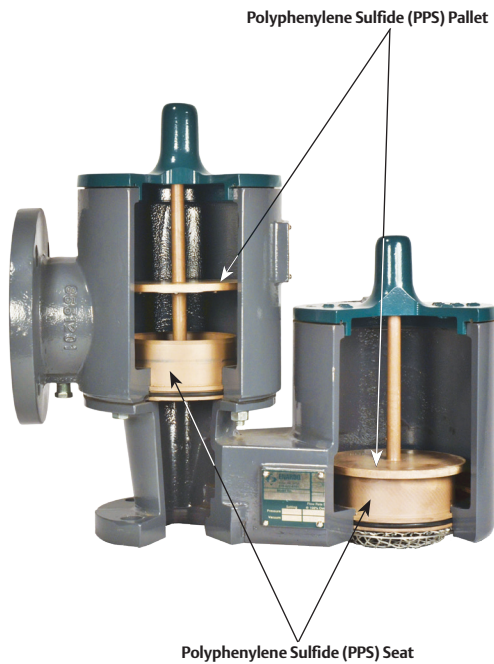

*seat is field replaceable

Figure 2. Enardo™ ES-850 Cut-Away View

Pallet and Seat

Enardo Saber® pallet guide system provides the only dual guided (top and bottom) pallet in the industry. This provides for smoother valve stroke, less flutter and valve wear. In addition the valve seat is a fully field replaceable pallet and seat assembly which eliminates the need to send the valve out for repair or replacement. By allowing field replacement the valve can be maintained by in house personnel allowing the customer to remain in total control. Replacement of the seat with certified replacement parts guarantees the valve is brought back to like new factory standard. All this can be done without need for special tools or complex procedures.

Advanced Materials and Construction

Material selection for the operational components of the valve is crucial for the valve's performance and reliability. Many applications subject the valve to stored or processed vapors which can be chemically hostile, corrosive and sticky, as well as to harsh environmental conditions such as extreme cold and heat. These conditions are the prime causes of deterioration, pitting, sticking and freezing, which cause leakage and possible valve failure. When used for the valve seat and pallet. Polyphenylene Sulfide (PPS) material provides greater resistance to these destructive factors when compared with conventional metal materials such as aluminum, ductile iron, carbon steel and stainless steel. (For more information on Polyphenylene Sulfide (PPS)'s corrosion resistance characteristics compared to 316 Stainless steel, ask for the Chemical Resistance Comparison of Polyphenylene Sulfide (PPS) to 316 Stainless steel.)

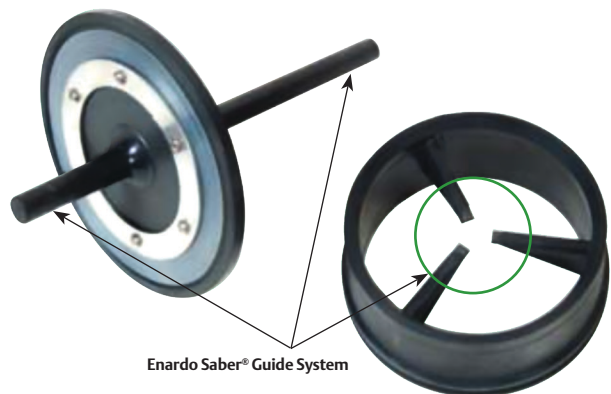

Figure 3. Enardo Saber® Guide System

Introduction

Enardo™ ES-850 pressure/vacuum relief valves are designed to provide enhanced sealing and allow easier compliance with tightening environmental emission regulations and reduced operational costs due to lower fugitive emissions and increased product retention. This relief valve provides protection against positive overpressure, evaporative loss of product and helps contain odorous and potentially hazardous vapors.

- The only dual guided (top and bottom) pallet for smoother valve stroke, less flutter and valve wear.
- Fully field replaceable pallet and seat assemblies without need for special tools or complex procedures which eliminates the need to send out for rebuilding or total valve replacement. (Can be maintained by in house maintenance personnel).
- All Enhanced Sealing improvements are completely backwards compatible with existing Enardo 850 valves via retrofit kits.
- Optional Remote Monitoring provides open/closed position information that can be viewed from a control room, to facilitate troubleshooting and immediate problem identification.

The Enardo ES-850 pipe-away design maintains a tight seal until system pressure or vacuum exceed the set pressure of the valve. When overpressure occurs the weighted pallet lifts, breaking the seal between the seat and pallet, allowing vapors to pass through the valve orifice and relieving the pressure or vacuum buildup. The valve reseals upon relief and remains sealed.

Available Vent Sizes

2 to 12 in. / 50 to 300 mm

Valve Setting Range

Pressure

2 to 6 in. / 50 to 150 mm size

0.5 to 32 oz./sq. in. (0.5 oz. increments)
 1.0 to 55 in. w.c. (0.5 in. w.c. increments)
 2.2 to 138 mbar (2.2 mbar increments)
 25 to 1406 mm w.c. (13 mm w.c. increments)

8 to 12 in. / 200 to 300 mm size

0.5 to 24 oz./sq. in. (0.5 oz. increments)
 1.0 to 41.5 in. w.c. (0.5 in. w.c. increments)
 2.2 to 103 mbar (2.2 mbar increments)
 25 to 1055 mm wc (13 mm w.c. increments)

Vacuum

2 to 6 in. / 50 to 150 mm size

0.4 to 32 oz./sq. in. (0.5 oz. increments)
 1.0 to 55 in. w.c. (0.5 in. w.c. increments)
 2.2 to 138 mbar (2.2 mbar increments)
 25 to 1406 mm w.c. (13 mm w.c. increments)

8 to 12 in. / 200 to 300 mm size

0.4⁽¹⁾ to 24 oz./sq. in. (0.5 oz. increments)
 1.0 to 41.5 in. w.c. (0.5 in. w.c. increments)
 2.2 to 103 mbar (2.2 mbar increments)
 25 to 1055 mm w.c. (13 mm w.c. increments)

Construction Materials

Housing

Aluminum
 Stainless Steel
 Carbon Steel

Seat/Pallet

316 Stainless steel

Pallet Seal

FEP
 Nitrile (NBR)
 Fluorocarbon (FKM)
 Fluorosilicone (FVMQ)

Hardware

Zinc-plated carbon steel
 Stainless steel

Weight

Zinc-plated carbon steel
 Stainless Steel
 Lead

Body Gasketing

Nitrile (NBR)
 FEP
 Fluorocarbon (FKM)
 Fluorosilicone (FVMQ)

Additional Technical Data



Figure 1. Enardo ES-850 High Performance PVRV Pipe Away

Features

- **Enardo Saber® Guide valve system provides for smooth valve stroke during operation and reduces valve wear**
- **Leakage rate of 0.1 SCFH @ 90% of set point is 10 times lower than the industry standard of 1 SCFH @ 90% for allowable leakage.**
- **Fully field replaceable pallet and seat assemblies**
- **Available in ANSI, DIN and JIS flanges**
- **Optional Remote Monitoring**
- **Retrofit kits available to upgrade existing valves to this Enhanced Sealing configuration**

For more technical information, contact your local Sales Office or log on to:

www.enardo.com

1. Maximum pressure setting is 16 oz./sq. in. when 0.4 oz. setting is used with FEP seals.

Enardo ES-850

Enhanced Sealing High Performance PVRV Pipe Away

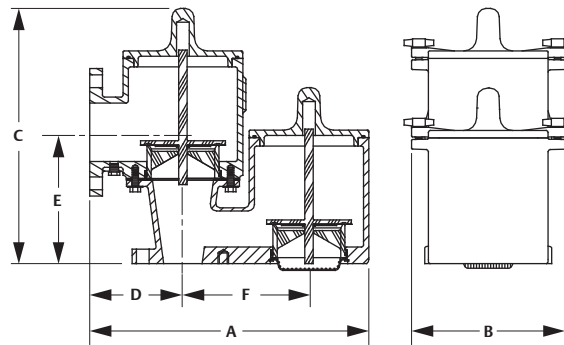

Figure 2. Enardo™ ES-850 Dimensions

Table 2. Enardo ES-850 Dimensions and Weights

INLET CONNECTION		OUTLET CONNECTION		A (OVERALL LENGTH)		B (OVERALL WIDTH)		C (OVERALL HEIGHT)		D (CL INLET)		E (CL I/O)		F (CL I/V)		WEIGHT (ALUMINUM) ⁽¹⁾		WEIGHT (STAINLESS STEEL) ⁽¹⁾	
In.	mm	In.	mm	In.	mm	In.	mm	In.	mm	In.	mm	In.	mm	In.	mm	Lb	kg	Lb	kg
2	50	3	80	16-1/2	419	9-1/8	232	15	381	5-1/2	140	7-1/2	191	7-7/16	189	29	13	80	36
3	80	3	80	16-1/2	419	9-1/8	232	15-1/2	394	5-1/2	140	8	203	7-7/16	189	31	14	85	39
3	80	4	100	16-1/2	419	9-1/8	232	15-1/2	394	5-11/16	144	8	203	7-7/16	189	33	15	90	41
4	100	6	150	22-3/8	562	11	279	19-1/2	495	6-21/32	169	9-1/2	241	9-13/16	249	57	26	144	65
6	150	6	150	22-3/8	568	11	279	21-3/4	552	6-1/4	159	11-7/8	302	10	254	62	28	155	70
6	150	8	200	24-3/8	619	13-3/4	349	21-3/4	552	8-5/8	219	13	330	10	254	70	32	178	81
8	200	10	250	35-3/4	908	16-1/8	410	27-3/4	705	10-1/2	267	13-1/2	343	17-1/8	435	161	73	485	220
10	250	10	250	35-3/4	908	16-1/8	410	29-1/4	743	10-1/2	267	15-1/4	387	17-1/8	435	166	75	503	228
10	250	12	300	37-1/4	946	16-1/8	410	29-1/4	743	12	305	15-1/4	387	17-1/8	435	172	78	525	238
12	300	12	300	38-13/16	986	20-3/4	527	37-7/16	951	12	305	23-11/16	602	19-1/16	484	175	79	532	241
12	300	14	350	45-7/16	1154	24	610	39-5/8	1006	16	406	27-5/16	694	19-1/16	484	208	94	622	282

1. Unit weights indicate Net Weight of valve in pounds at standard set pressure (0.5 oz./sq. in. pressure - 0.5 oz./sq. in. vacuum), does not include shipping crate or box. Add 20% for gross shipping weight (Domestic Only).

Key to Enardo ES-850 Model Number

Model	Inlet Size	Outlet Size	Housing Material	Pallet and Seat Material	Pallet Seal Material	Body/Seat/Lid Seal Material
ES-850	2 to 12 in.	3 to 14 in.	1 = Aluminum 4 = 316SST 5 = Carbon Steel	2 = 316SST	1 = FEP 2 = Nitrile (NBR) 3 = Fluorocarbon (FKM) 4 = Fluorosilicone (FVMQ)	1 = PTFE Body and FEP Seat/Lid 2 = Nitrile (NBR) 3 = Fluorocarbon (FKM) 4 = Fluorosilicone (FVMQ)

Pressure Units ⁽¹⁾	Pressure Setting ⁽¹⁾	Vacuum Units ⁽¹⁾	Vacuum Setting ⁽¹⁾	Weight Material	Options
z = oz./sq.in. n = in. w.c. mm = mm w.c. mb = mbar	0.5 to 32.0 oz./sq.in. 1.0 to 55.0 in. w.c. 25 to 1406 mm w.c. 2.2 to 138 mbar	z = oz./sq.in. n = in. w.c. mm = mm w.c. mb = mbar	0.4 to 32.0 oz./sq.in. 1.0 to 55.0 in. w.c. 25 to 1406 mm w.c. 2.2 to 138 mbar	C = CS ZP S = SST L = Lead	0 = No Options F = Flat Face Flange (standard for Aluminum) R = Raised Face Flange (standard for CS, SS) X = Epoxy Coating W1 = Wireless Pressure and Vacuum Monitoring W2 = Wireless Pressure Monitoring Only W3 = Wireless Vacuum Monitoring Only W4 = Wired Pressure and Vacuum Monitoring W5 = Wired Pressure Monitoring Only W6 = Wired Vacuum Monitoring Only

1. Refer to Valve Setting Range (Pressure) for pressure relief guidelines.

Example:

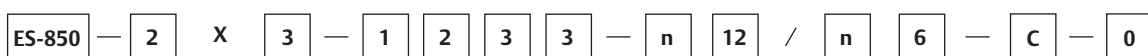

Indicates an enhanced sealing Pipe-Away pressure vacuum relief valve with 2 in. inlet by 3 in. outlet, ANSI 150 lb. raised face flange pattern connections, Aluminum housing, 316SST Pallet and Seat, FKM Pallet Seal, with FKM Body, Lid and Seat gaskets. Pressure setting is 12 in. w.c. and vacuum setting is 6 in. w.c. Carbon steel weight material and no additional option.



Enardo ES-950

Enhanced Sealing High Performance PVRV Vent-to-Atmosphere

Introduction

Enardo™ ES-950 pressure/vacuum relief valves are designed to provide enhanced sealing and allow easier compliance with tightening environmental emission regulations and reduced operational costs due to lower fugitive emissions and increased product retention.

- The only dual guided (top and bottom) pallet for smoother valve stroke, less flutter and valve wear.
- Fully field replaceable pallet and seat assemblies without need for special tools or complex procedures which eliminates the need to send out for rebuilding or total valve replacement. (Can be maintained by in house maintenance personnel).
- All Enhanced Sealing improvements are completely backwards compatible with existing Enardo 950 valves via retrofit kits.
- Optional Remote Monitoring provides open/closed position information that can be viewed from a control room, to facilitate troubleshooting and immediate problem identification.

The Enardo ES-950 vent-to-atmosphere design maintains a tight seal until system pressure or vacuum exceed the set pressure of the valve. When overpressure occurs the weighted pallet lifts, breaking the seal between the seat and pallet, allowing vapors to pass through the valve orifice and relieving the pressure or vacuum buildup. The valve reseals upon relief and remains sealed.

Inlet Connection Sizes

2 to 12 in. / 50 to 300 mm

Valve Setting Range

Pressure

2 to 6 in. / 50 to 150 mm size

0.5 to 32 oz./sq. in. (0.5 oz. increments)
1.0 to 55 in. w.c. (0.5 in. w.c. increments)
2.2 to 138 mbar (2.2 mbar increments)
25 to 1406 mm w.c. (13 mm w.c. increments)

8 to 12 in. / 200 to 300 mm size

0.5 to 24 oz./sq. in. (0.5 oz. increments)
1.0 to 41.5 in. w.c. (0.5 in. w.c. increments)
2.2 to 103 mbar (2.2 mbar increments)
25 to 1055 mm w.c. (13 mm w.c. increments)

Vacuum

2 to 6 in. / 50 to 150 mm size

0.4 to 32 oz./sq. in. (0.5 oz. increments)
1.0 to 55 in. w.c. (0.5 in. w.c. increments)
2.2 to 138 mbar (2.2 mbar increments)
25 to 1406 mm w.c. (13 mm w.c. increments)

8 to 12 in. / 200 to 300 mm size

0.4⁽¹⁾ to 24 oz./sq. in. (0.5 oz. increments)
1.0 to 41.5 in. w.c. (0.5 in. w.c. increments)
2.2 to 103 mbar (2.2 mbar increments)
25 to 1055 mm w.c. (13 mm w.c. increments)

Construction Materials

Housing

Aluminum
Stainless Steel
Carbon Steel

Seat/Pallet

316 Stainless steel

Pallet Seal

FEP
Nitrile (NBR)
Fluorocarbon (FKM)
Fluorosilicone (FVMQ)

Hardware

Zinc-plated carbon steel
Stainless steel

Weight

Zinc-plated carbon steel
Stainless steel
Lead

Body Gasketing

Nitrile (NBR)
FEP
Fluorocarbon (FKM)
Fluorosilicone (FVMQ)

Additional Technical Data



Figure 1. Enardo ES-950 Enhanced Sealing High Performance PVRV Vent-to-Atmosphere

Features

- **Enardo Saber® Guide valve system provides for smooth valve stroke during operation and reduces valve wear.**
- **Leakage rate of 0.1 SCFH at 90% of set point is 10 times lower than the industry standard of 1 SCFH at 90% for allowable leakage.**
- **Fully field replaceable pallet and seat assemblies.**
- **Available in ANSI, DIN and JIS flanges.**
- **Optional Remote Monitoring.**
- **Retrofit kits available to upgrade existing valves to this Enhanced Sealing configuration.**

For more technical information, contact your local Sales Office or log on to:

www.enardo.com

1. Maximum pressure setting is 16 oz./sq. in. when 0.4 oz. setting is used with FEP seals.

Enardo ES-950

Enhanced Sealing High Performance PVRV Vent-to-Atmosphere

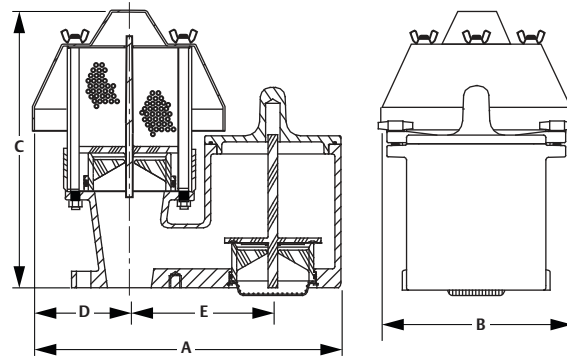

Figure 2. Enardo™ ES-950 Dimensions

Table 1. Enardo ES-950 Dimensions and Weights⁽¹⁾

INLET CONNECTION		A (OVERALL LENGTH)		B (OVERALL WIDTH)		C (OVERALL HEIGHT)		D (CL INLET)		E (CL I/O)		WEIGHT (ALUMINUM)		WEIGHT (STAINLESS STEEL OR CARBON STEEL)	
In.	mm	In.	mm	In.	mm	In.	mm	In.	mm	In.	mm	Lb	kg	Lb	kg
2	50	16	406	10	254	14-3/8	365	5	127	7-7/16	189	21	10	54	24
3	80	16	406	10	254	14-3/4	375	5	127	7-7/16	189	23	10	58	26
4	100	22-1/2	572	14	356	19-1/8	486	7	178	9-13/16	249	41	19	110	50
6	150	22-3/4	578	14	356	21-3/8	543	7	178	10	254	45	20	123	56
8	200	36-3/4	933	23	584	25-1/4	641	11-1/2	292	17-1/8	435	123	56	362	164
10	250	36-3/4	933	23	584	26-3/4	679	11-1/2	292	17-1/8	435	129	59	383	174
12	300	40-15/16	1040	23	584	34-3/4	883	11-1/2	292	19-1/16	484	144	65	405	184

1. Unit weights indicate Net Weight of valve in pounds at standard set pressure (0.5 oz./sq. in. pressure - 0.5 oz./sq. in. vacuum), does not include shipping crate or box. Add 20% for gross shipping weight (Domestic Only).

Key to Enardo ES-950 Model Number

Model	Inlet Size	Housing Material	Pallet and Seat Material	Pallet Seal Material	Body/Seat/Lid Seal Material
ES-950	2 to 12 in.	1 = Aluminum 4 = 316SST 5 = Carbon Steel	2 = 316SST	1 = FEP 2 = Nitrile (NBR) 3 = Fluorocarbon (FKM) 4 = Fluorosilicone (FVMQ)	1 = PTFE Body and FEP Seat/Lid 2 = Nitrile (NBR) 3 = Fluorocarbon (FKM) 4 = Fluorosilicone (FVMQ)

Pressure Units ⁽¹⁾	Pressure Setting ⁽¹⁾	Vacuum Units ⁽¹⁾	Vacuum Setting ⁽¹⁾	Weight Material	Options
z = oz./sq.in. n = in. w.c. mm = mm w.c. mb = mbar	0.5 to 32.0 oz./sq.in. 1.0 to 55.0 in. w.c. 25 to 1406 mm w.c. 2.2 to 138 mbar	z = oz./sq.in. n = in. w.c. mm = mm w.c. mb = mbar	0.4 to 32.0 oz./sq.in. 1.0 to 55.0 in. w.c. 25 to 1406 mm w.c. 2.2 to 138 mbar	C = CS ZP S = SST L = Lead	0 = No Options F = Flat Face Flange (standard for Aluminum) R = Raised Face Flange (standard for CS, SS) X = Epoxy Coating W1 = Wireless Pressure and Vacuum Monitoring W2 = Wireless Pressure Monitoring Only W3 = Wireless Vacuum Monitoring Only W4 = Wired Pressure and Vacuum Monitoring W5 = Wired Pressure Monitoring Only W6 = Wired Vacuum Monitoring Only

1. Refer to Valve Setting Range (Pressure) for pressure relief guidelines.

Example:



Indicates an enhanced sealing vent-to-atmosphere pressure vacuum relief valve with 2 in. inlet, ANSI 150 lb. flat face flange pattern connections, Aluminum housing, 316SST Pallet and Seat, FKM Pallet Seal, with FKM Body, Lid and Seat gaskets. Pressure setting is 12 in. w.c. and vacuum setting is 6 in. w.c. Carbon steel weight material. No options.

Introduction

Enardo™ 850 pressure vacuum relief valves are designed with features to exceed the performance of standard valves on the market. Standard features include:

- The only dual guided (top and bottom) pallet for smoother valve stroke, less flutter and valve wear.
- Polyphenylene Sulfide (PPS), advanced composite thermoplastic material for seat and pallet providing superior resistance to corrosion, chemical attack, liquid and vapor adhesion, temperature extremes (-50 to 500° F) and sticking due to valve seat freeze.
- Fully field replaceable pallet and seat assemblies without need for special tools or complex procedures which eliminates the need to send out for rebuilding or total valve replacement. (Can be maintained by in house maintenance personnel).
- Optional Remote Monitoring provides open/closed position information that can be viewed from a control room, to facilitate troubleshooting and immediate problem identification.

The Enardo 850 pipe-away design maintains a tight seal until system pressure or vacuum exceed the set pressure of the valve. When overpressure occurs the weighted pallet lifts, breaking the seal between the seat and pallet, allowing vapors to pass through the valve orifice and relieving the pressure or vacuum buildup. The valve reseals upon relief and remains sealed.

Available Vent Sizes

2 to 12 in. / 50 to 300 mm

Valve Setting Range

Pressure

0.5 to 32.0 oz./sq. in.
(0.5 oz./sq. in. increments)
1.0 to 55.0 in. w.c.
(0.5 in. w.c. increments)
2.0 to 138.0 mbar
(2.2 mbar increments)
5.0 to 1375 mm w.c.
(1.0 mm w.c. increment)

Vacuum

0.5 to 32.0 oz./sq. in.
(0.5 oz./sq. in. increments)
1.0 to 55.0 in. w.c.
(0.5 in. w.c. increments)
2.0 to 138.0 mbar
(2.2 mbar increments)
5.0 to 1375 mm w.c.
(1.0 mm w.c. increment)

Construction Materials

Housing

Aluminum
Stainless Steel
Carbon Steel

Seat/Pallet

Polyphenylene Sulfide (PPS)
316 Stainless steel

Pallet Seal

FEP Teflon®
Buna-N
Viton®

Hardware

Zinc-plated carbon steel
Stainless steel

Weight

Zinc-plated carbon steel
Stainless Steel
Lead

Gasket

Buna-N
Teflon®
Viton®

Additional Technical Data

For more technical information, contact your local Sales Office or log on to:

www.enardo.com



Figure 1. Enardo 850 High Performance PVRV Pipe Away

Features

- **Advanced composite thermoplastic Polyphenylene Sulfide (PPS) materials for seat and pallet provide superior resistance to corrosion, chemical attack, liquid and vapor adhesion, temperature extremes (-50 to 500° F) and sticking due to valve seat freeze**
- **Enardo Saber® Guide valve system provides for smooth valve stroke during operation and reduces valve wear**
- **Exceeds the most stringent standards for allowable leakage (1 SCFH @ 90% setpoint per valve) and provides excellent setpoint accuracy (+/-3%)**
- **Fully field replaceable pallet and seat assemblies**
- **Available in ANSI, DIN and JIS flanges**
- **EN 13463-1 and EN 13463-5 Certified**
- **Optional Remote Monitoring**

Teflon® and Viton® are marks owned by E. I. du Pont de Nemours and Company.

Enardo 850

High Performance PVRV Pipe Away

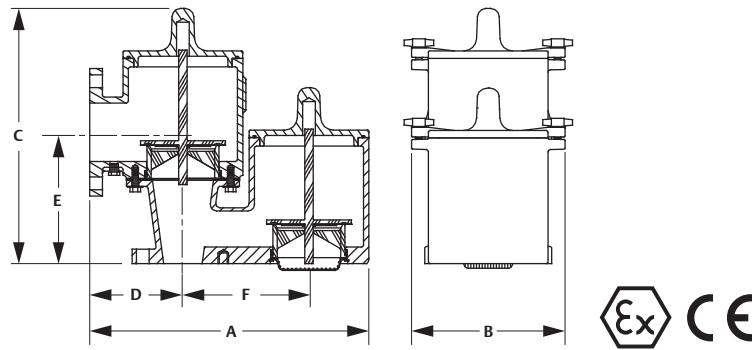

Figure 2. Enardo™ 850 Dimensions

Table 2. Enardo 850 Dimensions and Weights

INLET CONNECTION		OUTLET CONNECTION		A (OVERALL LENGTH)		B (OVERALL WIDTH)		C (OVERALL HEIGHT)		D (CL INLET)		E (CL I/O)		F (CL I/V)		WEIGHT (ALUMINUM) ⁽¹⁾		WEIGHT (STAINLESS STEEL) ⁽¹⁾	
In.	mm	In.	mm	In.	mm	In.	mm	In.	mm	In.	mm	In.	mm	In.	mm	Lb	kg	Lb	kg
2	50	3	80	16-1/2	419	9-1/8	232	15	381	5-1/2	140	7-1/2	191	7-7/16	189	29	13	80	36
3	80	3	80	16-1/2	419	9-1/8	232	15-1/2	394	5-1/2	140	8	203	7-7/16	189	31	14	85	39
3	80	4	100	16-1/2	419	9-1/8	232	15-1/2	394	5-11/16	144	8	203	7-7/16	189	33	15	90	41
4	100	6	150	22-1/8	562	11	279	19-1/2	495	6-21/32	169	9-1/2	241	9-13/16	249	57	26	144	65
6	150	6	150	22-3/8	568	11	279	21-3/4	552	6-1/4	159	11-7/8	302	10	254	62	28	155	70
6	150	8	200	24-3/8	619	13-3/4	349	21-3/4	552	8-5/8	219	13	330	10	254	70	32	178	81
8	200	10	250	35-3/4	908	16-1/8	410	27-3/4	705	10-1/2	267	13-1/2	343	17-1/8	435	161	73	485	220
10	250	10	250	35-3/4	908	16-1/8	410	29-1/4	743	10-1/2	267	15-1/4	387	17-1/8	435	166	75	503	228
10	250	12	300	37-1/4	946	16-1/8	410	29-1/4	743	12	305	15-1/4	387	17-1/8	435	172	78	525	238
12	300	12	300	38-13/16	986	20-3/4	527	37-7/16	951	12	305	23-11/16	602	19-1/16	484	175	79	532	241
12	300	14	350	45-7/16	1154	24	610	39-5/8	1006	16	406	27-5/16	694	19-1/16	484	208	94	622	282

1. Unit weights indicate Net Weight of valve in pounds at standard set pressure (0.5 oz./sq. in. pressure - 0.5 oz./sq. in. vacuum), does not include shipping crate or box. Add 20% for gross shipping weight (Domestic Only).

Key to Enardo 850 Model Number

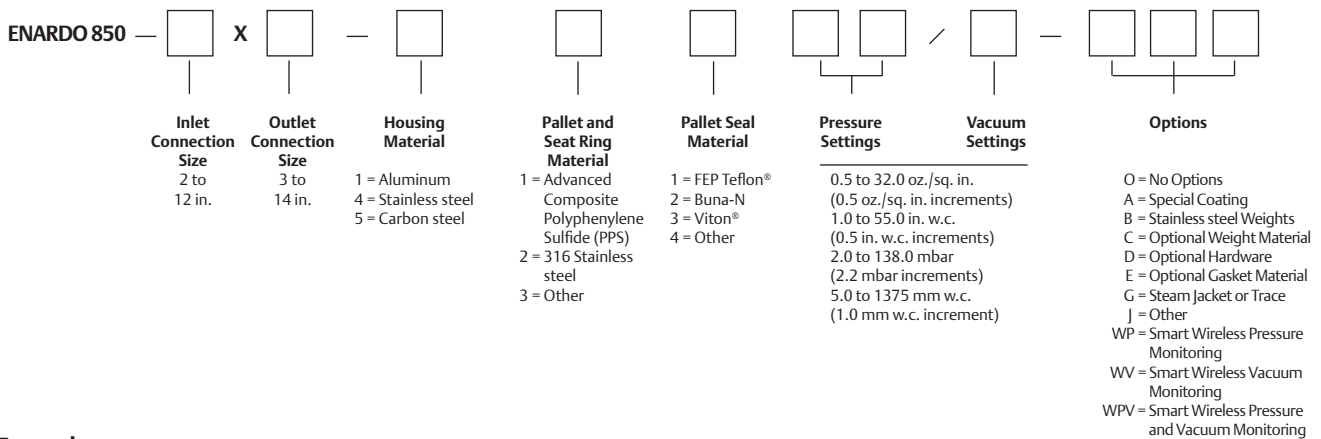

Example:



Indicates a Pipe-Away pressure vacuum relief valve with 2 in. inlet by 3 in. outlet, ANSI 150 lb. raised face flange pattern connections, carbon steel housing, stainless steel pallet and seat ring and FEP Teflon® pallet seal. Pressure setting is 12 in. w.c. and vacuum setting is 6 in. w.c. Options include special external epoxy coating of valve and stainless steel weights for relief settings.

Teflon® and Viton® are marks owned by E. I. du Pont de Nemours and Company.



Introduction

Enardo™ 950 pressure vacuum relief valves are designed with features to exceed the performance of standard valves on the market. Standard features include:

- The only dual guided (top and bottom) pallet for smoother valve stroke, less flutter and valve wear.
- Polyphenylene Sulfide (PPS), advanced composite thermoplastic material for seat and pallet providing superior resistance to corrosion, chemical attack, liquid and vapor adhesion, temperature extremes (-50 to 500°F) and sticking due to valve seat freeze.
- Fully field replaceable pallet and seat assemblies without need for special tools or complex procedures which eliminates the need to send out for rebuilding or total valve replacement. (Can be maintained by in house maintenance personnel).
- Optional Remote Monitoring provides open/closed position information that can be viewed from a control room, to facilitate troubleshooting and immediate problem identification.

The Enardo 950 vent-to-atmosphere design maintains a tight seal until system pressure or vacuum exceed the set pressure of the valve. When overpressure occurs the weighted pallet lifts, breaking the seal between the seat and pallet, allowing vapors to pass through the valve orifice and relieving the pressure or vacuum buildup. The valve reseals upon relief and remains sealed.

Inlet Connection Sizes

2 to 12 in. / 50 to 300 mm

Valve Setting Range

Pressure

0.5 to 32.0 oz./sq. in.
(0.5 oz./sq. in. increments)
1.0 to 55.0 in. w.c.
(0.5 in. w.c. increments)
2.0 to 138.0 mbar
(2.2 mbar increments)
5.0 to 1375 mm w.c.

Vacuum

0.5 to 32.0 oz./sq. in.
(0.5 oz./sq. in. increments)
1.0 to 55.0 in. w.c.
(0.5 in. w.c. increments)
2.0 to 138.0 mbar
(2.2 mbar increments)
5.0 to 1375 mm w.c.

Construction Materials

Housing

Aluminum
Stainless Steel
Carbon Steel

Seat/Pallet

Polyphenylene Sulfide (PPS)
316 Stainless steel

Pallet Seal

FEP Teflon®
Buna-N
Viton®

Hardware

Zinc-plated carbon steel
Stainless steel

Weight

Zinc-plated carbon steel
Stainless steel
Lead

Gasket

Buna-N
Teflon®
Viton®

Additional Technical Data

For more technical information, contact your local Sales Office or log on to:

www.enardo.com



Figure 1. Enardo 950 High Performance PVRV Vent-to-Atmosphere

Features

- **Advanced composite thermoplastic Polyphenylene Sulfide (PPS) materials for seat and pallet provide superior resistance to corrosion, chemical attack, liquid and vapor adhesion, temperature extremes (-50 to 500°F) and sticking due to valve seat freeze**
- **Enardo Saber® Guide valve system provides for smooth valve stroke during operation and reduces valve wear**
- **Exceeds the most stringent standards for allowable leakage (1 SCFH at 90% setpoint per valve) and provides excellent setpoint accuracy (+/-3%)**
- **Fully field replaceable pallet and seat assemblies.**
- **Available in ANSI, DIN and JIS flanges**
- **EN 13463-1 and EN 13463-5 Certified**
- **Optional Remote Monitoring**

Teflon® and Viton® are marks owned by E. I. du Pont de Nemours and Company.

Enardo 950

High Performance PVRV Vent-to-Atmosphere

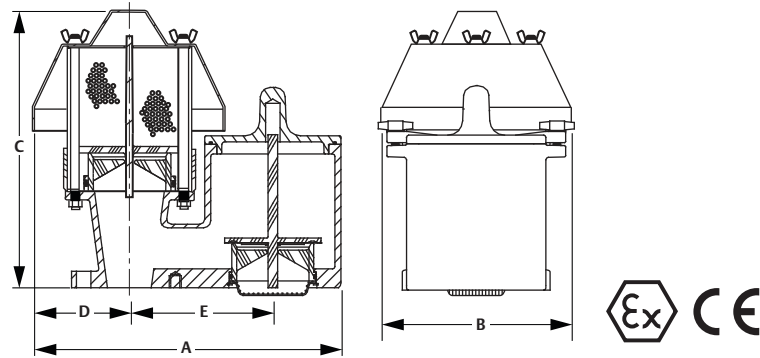

Figure 2. Enardo™ 950 Dimensions

Table 1. Enardo 950 Dimensions and Weights⁽¹⁾

INLET CONNECTION		A (OVERALL LENGTH)		B (OVERALL WIDTH)		C (OVERALL HEIGHT)		D (CL INLET)		E (CL l/O)		WEIGHT (ALUMINUM)		WEIGHT (STAINLESS STEEL OR CARBON STEEL)	
In.	mm	In.	mm	In.	mm	In.	mm	In.	mm	In.	mm	Lb	kg	Lb	kg
2	50	16	406	10	254	14-3/8	365	5	127	7-7/16	189	21	10	54	24
3	80	16	406	10	254	14-3/4	375	5	127	7-7/16	189	23	10	58	26
4	100	22-1/2	572	14	356	19-1/8	486	7	178	9-13/16	249	41	19	110	50
6	150	22-3/4	578	14	356	21-3/8	543	7	178	10	254	45	20	123	56
8	200	36-3/4	933	23	584	25-1/4	641	11-1/2	292	17-1/8	435	123	56	362	164
10	250	36-3/4	933	23	584	26-3/4	679	11-1/2	292	17-1/8	435	129	59	383	174
12	300	40-15/16	1040	23	584	34-3/4	883	11-1/2	292	19-1/16	484	144	65	405	184

1. Unit weights indicate Net Weight of valve in pounds at standard set pressure (0.5 oz./sq. in. pressure - 0.5 oz./sq. in. vacuum), does not include shipping crate or box. Add 20% for gross shipping weight (Domestic Only).

Key to Enardo 950 Model Number

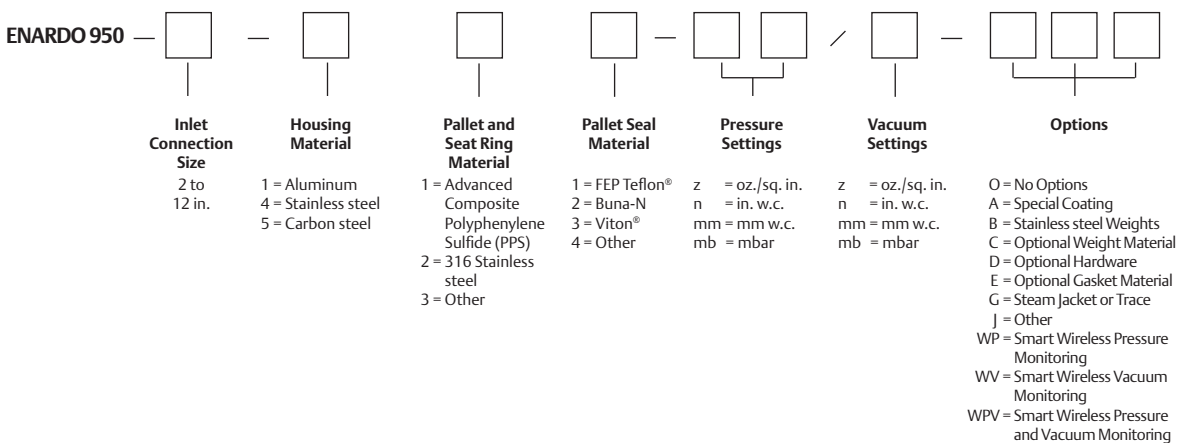

Example:



Indicates a vent-to-atmosphere pressure vacuum relief valve with 4 in. inlet, ANSI 150 lb. flat face flange pattern connections, aluminum housing, advanced composite Polyphenylene Sulfide (PPS) pallet and seat ring and FEP Teflon® pallet seal. Pressure setting is 10 in. w.c. and vacuum setting is 6 in. w.c. Option includes special external epoxy coating.

Teflon® and Viton® are marks owned by E. I. du Pont de Nemours and Company.

Introduction

The Wireless Monitoring Option is available for order with PVRV Enardo™ 850 and Enardo 950. This option allows the remote sensing of the open or closed position of the pressure and vacuum vents which enables immediate response to prevent problems related to safety, emissions and quality of the tank contents.

Application

Models

Enardo 850
Enardo 950

Size

2 to 12 in. / 50.8 to 305 mm

Pressure/Vacuum Sensing

Sensor triggers between 10% and 15% open

Transmitter Sample Rate

Once/8 seconds

Additional Technical Data

For more technical information, contact your local Sales Office or log on to:

www.enardo.com



Figure 1. Wireless Monitoring Option for Enardo 850 and Enardo 950

Table 1. Ordering Option Codes

SENSING TYPE	OPTION CODE
Pressure	WP
Vacuum	WV
Pressure and Vacuum	WPV

Features

- **Wireless transmitter which connects to the pressure and/or vacuum sides of the PVRV**
- **Built-in proximity sensors that allow the transmitter to detect the open or closed position of the vents**
- **Signals received by transmitter can be sent to a control room via a gateway**
- **Fully-tested and integrated design**

Enardo 851

High Performance Top Mount Pressure or Side Mount Vacuum Relief Valve

Introduction

Enardo™ 851 top mount pressure relief valves or side mount vacuum relief valves are advanced design for pipe-away applications. Utilizing the latest technologies, this relief valve provides protection against positive overpressure, prevents air intake, evaporative loss of product and helps contain odorous and potentially hazardous vapors.

Part of high performance line of pressure vacuum relief valves, the Enardo 851 was designed with features to exceed the performance of standard valves on the market. Unmatched features include Enardo Saber® Guide valve system and advanced composite Polyphenylene Sulfide (PPS) seat and trim for superior performance. Standard features include:

- The only dual guided (top and bottom) pallet for smoother valve stroke, less flutter and valve wear.
- Polyphenylene Sulfide (PPS), advanced composite thermoplastic material for seat and pallet providing superior resistance to corrosion, chemical attack, liquid and vapor adhesion, temperature extremes (-50 to 500°F) and sticking due to valve seat freeze.
- Fully field replaceable pallet and seat assemblies without need for special tools or complex procedures which eliminates the need to send out for rebuilding or total valve replacement (Can be maintained by in house maintenance personnel).
- Also available in spring-loaded design (Enardo 861).

Available Vent Sizes

2 to 12 in. / 50 to 300 mm

Valve Setting Range

Pressure

0.5 to 32.0 oz./sq. in.
(0.5 oz./sq. in. increments)
1.0 to 55.0 in. w.c.
(0.5 in. w.c. increments)
2.0 to 138.0 mbar
(2.2 mbar increments)
5.0 to 1375 mm w.c.

Vacuum

0.5 to 32.0 oz./sq. in.
(0.5 oz./sq. in. increments)
1.0 to 55.0 in. w.c.
(0.5 in. w.c. increments)
2.0 to 138.0 mbar
(2.2 mbar increments)
5.0 to 1375 mm w.c.

Construction Materials

Housing

Aluminum
Stainless steel
Carbon steel

Seat/Pallet

Polyphenylene Sulfide (PPS)
316 Stainless steel

Pallet Seal

FEP Teflon®
Buna-N
Viton®

Hardware

Zinc-plated carbon steel
Stainless steel

Weight

Zinc-plated carbon steel
Stainless Steel
Lead

Gasket

Buna-N
Teflon®
Viton®

Additional Technical Data

For more technical information, contact your local Sales Office or log on to:

www.enardo.com

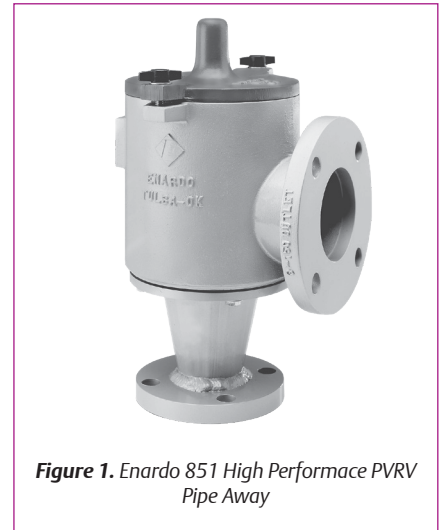

Figure 1. Enardo 851 High Performance PVRV Pipe Away

Features

- **Advanced composite thermoplastic Polyphenylene Sulfide (PPS) materials for seat and pallet provide superior resistance to corrosion, chemical attack, liquid and vapor adhesion, temperature extremes (-50 to 500°F) and sticking due to valve seat freeze.**
- **Enardo Saber® Guide valve system provides for smooth valve stroke during operation and reduces valve wear.**
- **Exceeds the most stringent standards for allowable leakage (1 SCFH @ 90% setpoint per valve) and provides excellent setpoint accuracy (+/-3%).**
- **Fully field replaceable pallet and seat assemblies.**
- **Available in ANSI, DIN and JIS flanges.**
- **EN 13463-1 and EN 13463-5 Certified.**

Teflon® and Viton® are marks owned by E. I. du Pont de Nemours and Company.

Enardo 951

High Performance Pressure Relief Valve - Top Mount

Introduction

Enardo™ 951 (top mount) pressure relief valves are advanced design for vent-to-atmosphere applications. Utilizing the latest technologies, this relief valve provides protection against positive overpressure, prevents air intake, evaporative loss of product and helps contain odorous and potentially hazardous vapors.

Part of high performance line of pressure vacuum relief valves, the Enardo 951 was designed with features to exceed the performance of standard valves on the market. Unmatched features include Enardo Saber® Guide valve system and advanced composite Polyphenylene Sulfide (PPS) seat and trim for superior performance.

Standard features include:

- The only dual guided (top and bottom) pallet for smoother valve stroke, less flutter and valve wear
- Polyphenylene Sulfide (PPS), advanced composite thermoplastic material for seat and pallet providing superior resistance to corrosion, chemical attack, liquid and vapor adhesion, temperature extremes (-50 to 500°F) and sticking due to valve seat freeze
- Fully field replaceable pallet and seat assemblies without need for special tools or complex procedures which eliminates the need to send out for rebuilding or total valve replacement (Can be maintained by in house maintenance personnel)

*Also available in spring-loaded design (Enardo 961).

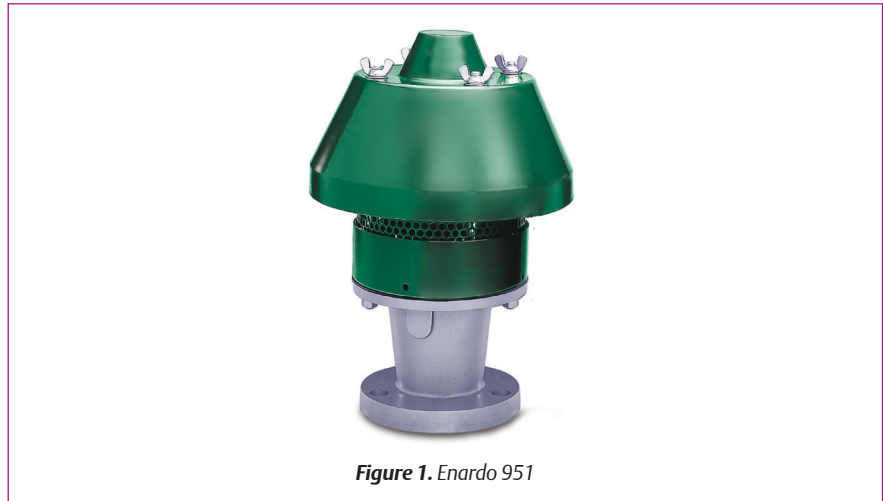

Figure 1. Enardo 951

Inlet Connection Sizes

2 through 12 in. / 50 through 300 mm

Valve Setting Range

0.5 to 32.0 oz./sq. in. (0.5 oz increments)
1.0 to 55.0 in. w.c. (0.5 in. increments)
2.0 to 138.0 mbar (2.2 mbar increments)
5.0 to 1375 mm w.c.

Construction Materials

Housing: Aluminum, Stainless steel or Carbon steel

Seat/Pallet: Polyphenylene Sulfide (PPS) or 316 Stainless steel

Pallet Seal: FEP Teflon®, Buna-N or Viton®
Hardware: Zinc-plated carbon steel or Stainless steel

Weights: Zinc-plated carbon steel
Stainless steel or Lead

Gaskets: Buna-N, Teflon® and Viton®

Additional Technical Data

For more technical information, contact your local Sales Office or log on to:

www.enardo.com

Features

- **Advanced composite thermoplastic Polyphenylene Sulfide (PPS) materials for seat and trim provide superior resistance to corrosion, chemical attack, liquid and vapor adhesion, temperature extremes (-50 to 500°F) and sticking due to valve seat freeze**
- **Enardo Saber® Guide valve system provides for smooth valve stroke during operation and reduces valve wear**
- **Exceeds the most stringent standards for allowable leakage (1 SCFH at 90% set point per valve) and provides excellent set point accuracy (+/-3%)**
- **Fully field replaceable pallet and seat assemblies**
- **Available in ANSI, DIN and JIS flanges**
- **EN 13463-1 and EN 13463-5 Certified**

Teflon® and Viton® are marks owned by E. I. du Pont de Nemours and Company.

Enardo 951

High Performance Pressure Relief Valve - Top Mount

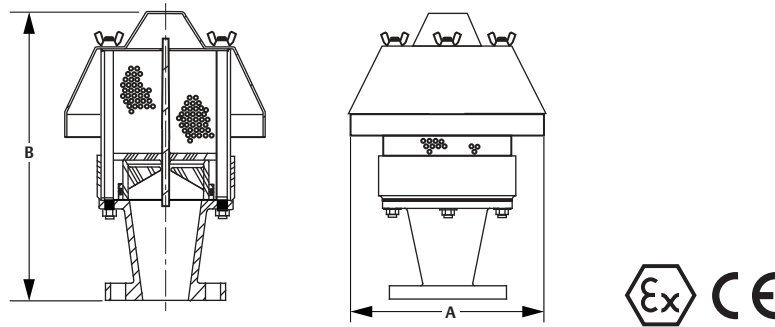

Figure 2. Enardo™ 951 Dimensions

Table 1. Enardo 951 Dimensions and Weights⁽¹⁾

INLET CONNECTION		A (OVERALL WIDTH)		B (OVERALL HEIGHT)		WEIGHT (ALUMINUM)		WEIGHT (STAINLESS STEEL)	
In.	mm	In.	mm	In.	mm	Lbs	kg	Lbs	kg
2	50	10	254	14-3/8	365	10	5	21	10
3	80	10	254	14-5/8	371	12	5	26	12
4	100	14	356	19-3/4	502	17	8	39	18
6	150	14	356	19-3/4	502	21	10	50	23
8	200	23	584	27-1/8	689	53	24	138	63
10	250	23	584	27-1/4	692	56	25	152	69
12	300	23	584	27-11/16	703	60	27	163	74

1. Unit weights indicate Net Weight of valve in pounds at standard set pressure (0.5 oz./sq. in. pressure - 0.5 oz./sq. in. vacuum), does not include shipping crate or box. Add 20% for gross shipping weight (Domestic Only).

Key to Enardo 951 Model Number

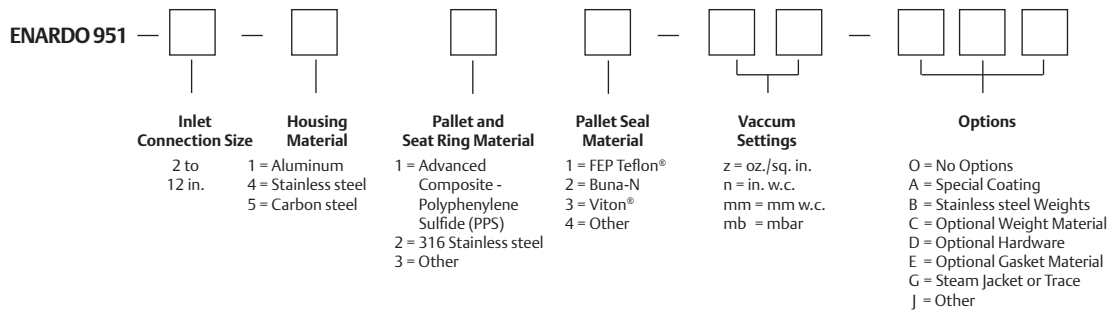

Example:



Indicates a Vent-to-Atmosphere vacuum relief valve with 4 in. inlet, ANSI 150 lb. flat face flange pattern connections, aluminum housing, advanced composite Polyphenylene Sulfide (PPS) pallet and seat ring and FEP Teflon® pallet seal. Pressure setting is 10 in. w.c.

Teflon® and Viton® are marks owned by E. I. du Pont de Nemours and Company.

Enardo 952

High Performance Vacuum Relief Valve - Top Mount

Introduction

Enardo™ 952 (top mount) vacuum relief valves are advanced design for vent-from-atmosphere applications. Utilizing the latest technologies, this relief valve provides protection against vacuum over pressure, prevents evaporative loss of product and helps contain odorous and potentially hazardous vapors.

Part of high performance line of pressure vacuum relief valves, the Enardo 952 was designed with features to exceed the performance of standard valves on the market. Unmatched features include Enardo Saber® Guide valve system and advanced composite Polyphenylene Sulfide (PPS) seat and trim for superior performance.

Standard features include:

- The only dual guided (top and bottom) pallet for smoother valve stroke, less flutter and valve wear.
- Polyphenylene Sulfide (PPS), advanced composite thermoplastic material for seat and pallet providing superior resistance to corrosion, chemical attack, liquid and vapor adhesion, temperature extremes (-50 to 500°F) and sticking due to valve seat freeze.
- Fully field replaceable pallet and seat assemblies without need for special tools or complex procedures which eliminates the need to send out for rebuilding or total valve replacement (can be maintained by in house maintenance personnel).

*Also available in spring-loaded design (Enardo 962).

Available Vent Sizes

2 to 12 in. / 50 to 300 mm

Valve Setting Range

Pressure

0.5 to 32.0 oz./sq. in.
(0.5 oz./sq. in. increments)
1.0 to 55.0 in. w.c.
(0.5 in. w.c. increments)
2.0 to 138.0 mbar
(2.2 mbar increments)
5.0 to 1375 mm w.c.
(1 mm w.c. increment)

Vacuum

0.5 to 32.0 oz./sq. in.
(0.5 oz./sq. in. increments)
1.0 to 55.0 in. w.c.
(0.5 in. w.c. increments)
2.0 to 138.0 mbar
(2.2 mbar increments)
5.0 to 1375 mm w.c.
(1 mm w.c. increment)

Construction Materials

Housing

Aluminum
Stainless steel
Carbon steel

Seat/Pallet

Polyphenylene Sulfide (PPS)
316 Stainless steel

Pallet Seal

FEP Teflon®
Buna-N
Viton®

Hardware

Zinc-plated carbon steel
Stainless steel

Weight

Zinc-plated carbon steel
Stainless steel
Lead
Resin-coated stainless steel

Gasket

Buna-N
Teflon®
Viton®

Additional Technical Data

For more technical information, contact your local Sales Office or log on to:

www.enardo.com



Figure 1. Enardo 952 High Performance Vacuum Relief Valve - Top Mount

Features

- **Advanced composite thermoplastic Polyphenylene Sulfide (PPS) materials for seat and pallet provide superior resistance to corrosion, chemical attack, liquid and vapor adhesion, temperature extremes (-50 to 500°F) and sticking due to valve seat freeze.**
- **Enardo Saber® Guide valve system provides for smooth valve stroke during operation and reduces valve wear.**
- **Exceeds the most stringent standards for allowable leakage (1 SCFH @ 90% setpoint per valve) and provides excellent setpoint accuracy (+/-3%).**
- **Fully field replaceable pallet and seat assemblies.**
- **Available in ANSI, DIN and JIS flanges.**
- **EN 13463-1 and EN 13463-5 certified.**

Teflon® and Viton® are marks owned by E. I. du Pont de Nemours and Company.

Enardo 952

High Performance Vacuum Relief Valve - Top Mount

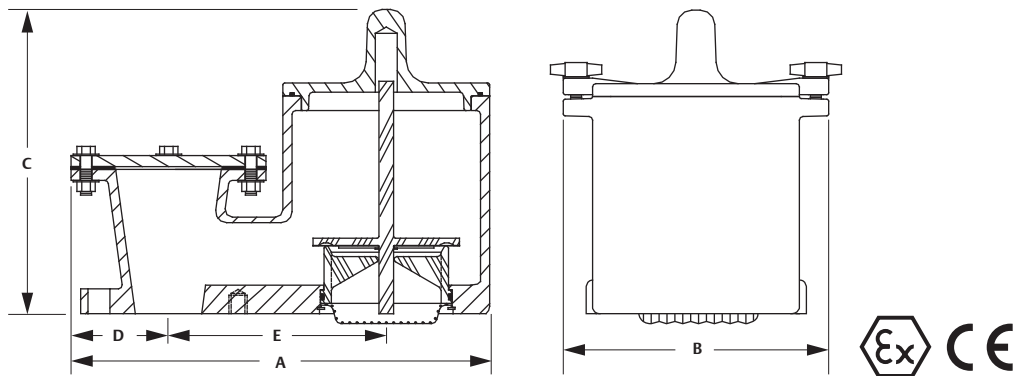

Figure 2. Enardo™ 952 Dimensions

Table 1. Enardo 952 Dimensions and Weights

INLET CONNECTION		A (OVERALL LENGTH)		B (OVERALL WIDTH)		C (OVERALL HEIGHT)		D (CL INLET)		E (CL I/O)		WEIGHT (ALUMINUM) ⁽¹⁾		WEIGHT (STAINLESS STEEL OR CARBON STEEL) ⁽¹⁾	
In.	mm	In.	mm	In.	mm	In.	mm	In.	mm	In.	mm	Lbs	kg	Lbs	kg
2	50	14-1/4	362	9-1/8	232	10-3/8	264	3-3/8	86	7-7/16	189	17	8	52	24
3	80	14-3/4	375	9-1/8	232	10-3/8	264	3-3/8	86	7-7/16	189	19	9	56	25
4	100	19-1/8	486	11	279	13-7/8	352	4-7/8	124	9-13/16	249	39	18	104	47
6	150	20-1/4	514	11	279	13-7/8	352	5-1/2	140	10	254	43	20	119	54
8	200	33-1/8	841	16-1/8	410	20-1/2	521	8-1/8	206	17-1/8	435	107	49	300	136
10	250	33-1/4	845	16-1/8	410	20-1/2	521	8	203	17-1/8	435	116	53	328	149
12	300	37-3/8	949	20-3/4	527	23-1/4	591	8	203	19-1/16	484	125	57	347	157

1. Unit weights indicate Net Weight of valve in pounds at standard set pressure (0.5 oz./sq. in. vacuum), does not include shipping crate or box. Add 20% for gross shipping weight (Domestic Only).

Key to Enardo 952 Model Number

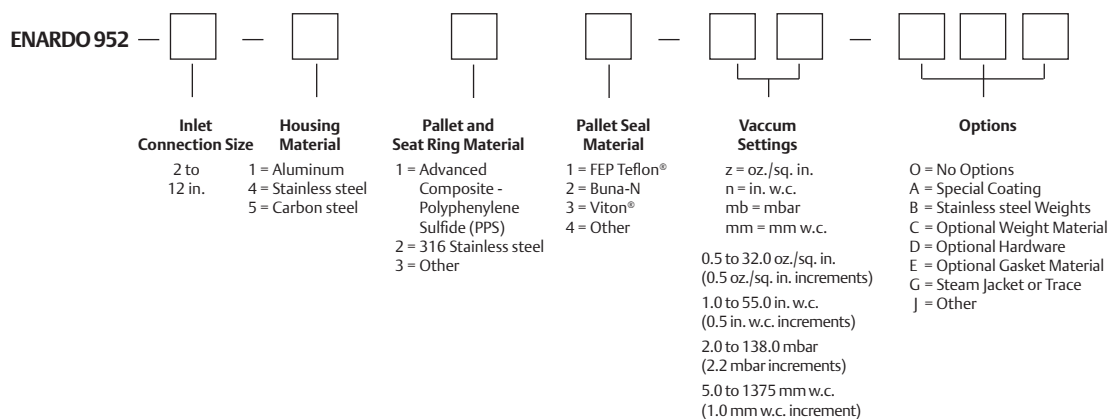

Example:



Indicates a Vent-to-Atmosphere vacuum relief valve with 4 in. inlet, ANSI 150 lb. flat face flange pattern connections, aluminum housing, advanced composite Polyphenylene Sulfide (PPS) pallet and seat ring and FEP Teflon® pallet seal. Vacuum setting is 10 in. w.c.

Teflon® and Viton® are marks owned by E. I. du Pont de Nemours and Company.

Enardo 953

High Performance Vacuum Relief Valve - Side Mount

Introduction

Enardo™ 953 (side mount) vacuum relief valves are advanced design for vent-from-atmosphere applications. Utilizing the latest technologies, this relief valve provides protection against vacuum over pressure, prevents evaporative loss of product and helps contain odorous and potentially hazardous vapors.

Part of high performance line of pressure vacuum relief valves, the Enardo 953 was designed with features to exceed the performance of standard valves on the market. Unmatched features include Enardo Saber® Guide valve system and advanced composite Polyphenylene Sulfide (PPS) seat and trim for superior performance.

Standard features include:

- The only dual guided (top and bottom) pallet for smoother valve stroke, less flutter and valve wear
- Polyphenylene Sulfide (PPS), advanced composite thermoplastic material for seat and pallet providing superior resistance to corrosion, chemical attack, liquid and vapor adhesion, temperature extremes (-50 to 500°F) and sticking due to valve seat freeze
- Fully field replaceable pallet and seat assemblies without need for special tools or complex procedures which eliminates the need to send out for rebuilding or total valve replacement (Can be maintained by in house maintenance personnel)

*Also available in spring-loaded design (Enardo 963).

Available Sizes

2 to 12 in. / 50 to 300 mm



Figure 1. Enardo 953

Valve Setting Range

0.5 to 32.0 oz./sq. in.
(0.5 oz Increments)
1.0 to 55.0 in. w.c.
(0.5 in. Increments)
2.0 to 138.0 mbar
(2.2 mbar Increments)
5.0 to 1375 mm w.c.

Construction Materials

Housing: Aluminum, Stainless steel or Carbon steel

Seat/Pallet: Polyphenylene Sulfide (PPS) or 316 Stainless steel

Pallet Seal: FEP Teflon®, Buna-N or Viton®

Hardware: Zinc-plated Carbon steel or Stainless steel

Weights: Zinc-Plated Carbon Steel, Stainless steel or Lead

Gaskets: Buna-N, Teflon® or Viton®

Additional Technical Data

For more technical information, contact your local Sales Office or log on to:

www.enardo.com

Features

- **Advanced composite thermoplastic Polyphenylene Sulfide (PPS), materials for seat and trim provide superior resistance to corrosion, chemical attack, liquid and vapor adhesion, temperature extremes (-50 to 500°F) and sticking due to valve seat freeze.**
- **Enardo Saber® Guide valve system provides for smooth valve stroke during operation and reduces valve wear.**
- **Exceeds the most stringent standards for allowable leakage (1 SCFH at 90% set point per valve) and provides excellent set point accuracy (+/-3%).**
- **Fully field replaceable pallet and seat assemblies.**
- **Available in ANSI, DIN and JIS flanges.**
- **EN 13463-1, EN 13463-5: Certified.**

Teflon® and Viton® are marks owned by E. I. du Pont de Nemours and Company.

Marine Vapor Control System

Pressure Vacuum Relief Valve

Introduction

The Marine Vapor Control system pressure vacuum relief valve line is specially designed to meet the requirements of CFR33 Part 154 for U.S. Coast Guard Marine Vapor Control Systems.

Enardo™ 850/MVC pressure vacuum pipe-away includes a 30 x 30 stainless steel flame screen for valve inlet and outlet, goose neck weather hood, Teflon® internal gaskets and 316 Stainless steel hardware.

Enardo 952/MVC vacuum relief valve also includes the 30 x 30 stainless steel flame screen for the inlet, Teflon® internal gaskets and 316 Stainless steel hardware.

Pallet and seat assemblies are fully field replaceable without having special tools or complex procedures which eliminates the need to send out for rebuilding or total valve replacement. These can be maintained by in house maintenance personnel.

Available Models

Enardo 850/MVC
Enardo 952/MVC

Available Vent Sizes

4 to 12 in. / 100 to 300 mm

Valve Setting Range

Pressure

0.5 to 32.0 oz./sq. in.
(0.5 oz./sq. in. increments)
1.0 to 55.0 in. w.c.
(0.5 in. w.c. increments)
2.0 to 138.0 mbar
(2.2 mbar increments)
25 to 1397 mm w.c.
(13 mm w.c. Increments)

Vacuum

0.5 to 32.0 oz./sq. in.
(0.5 oz./sq. in. increments)
1.0 to 55.0 in. w.c.
(0.5 in. w.c. increments)
2.0 to 138.0 mbar
(2.2 mbar increments)
25 to 1397 mm w.c.
(13 mm w.c. increments)



Figure 1. Marine Vapor Control System Application

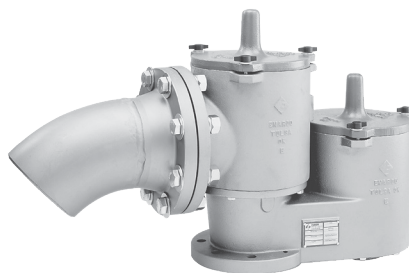

Figure 2. Enardo 850/MVC

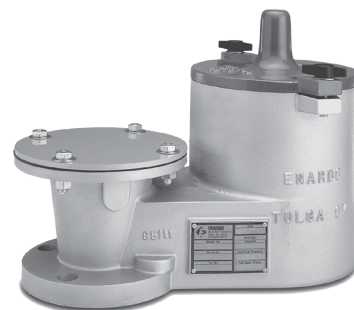

Figure 3. Enardo 952/MVC

Construction Materials

Housing

Carbon steel (12 in. only)

Seat/Pallet

316 Stainless steel

Pallet Seal

FEP Teflon®

Hardware

Stainless steel

Weight

Stainless steel

Gasket

Teflon®

Additional Technical Data

For more technical information, contact your local Sales Office or log on to:

www.enardo.com

Features

- Enardo Saber® Guide valve system provides for smooth valve stroke during operation and reduces valve wear.
- Exceeds the most stringent standards for allowable leakage (1 SCFH at 90% setpoint per valve) and provides excellent setpoint accuracy (+/-3%).
- Fully field replaceable pallet and seat assemblies.
- Available in ANSI, DIN and JIS flanges.
- EN 13463-1 and EN 13463-5 Certified.

Teflon® is a mark owned by E. I. du Pont de Nemours and Company.

Marine Vapor Control System

Pressure Vacuum Relief Valve

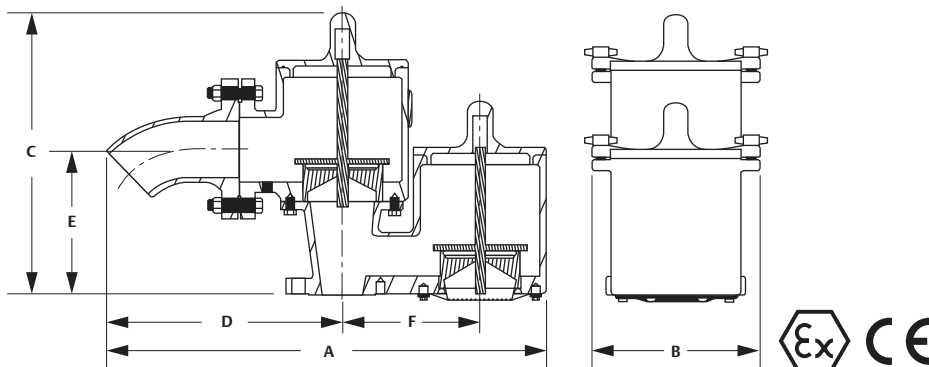

Figure 2. Enardo™ 850/MVC Dimensions

Table 1. Enardo 850/MVC Dimensions and Weights

INLET CONNECTION		OUTLET CONNECTION		A (OVERALL LENGTH)		B (OVERALL WIDTH)		C (OVERALL HEIGHT)		D (CL INLET)		E (CL I/O)		F (CL I/V)	
In.	mm	In.	mm	In.	mm	In.	mm	In.	mm	In.	mm	In.	mm	In.	mm
4	100	6	150	34-1/2	876	11	279	19-1/2	495	18-7/8	479	9-1/2	241	9-13/16	249
6	150	8	200	39-7/8	1013	13-3/4	349	21-3/4	552	24	610	13	330	10	254
8	200	10	250	54-1/8	1375	16-1/8	410	37-3/4	705	28-7/8	733	13-3/4	349	17-1/8	435
10	250	10	250	54-1/8	1375	16-1/8	410	29-1/4	743	28-7/8	733	15-1/4	387	17-1/8	435
10	250	12	300	58-7/8	1495	16-1/8	410	29-1/4	743	33-5/8	854	15-1/4	387	17-1/8	435
12	300	12	300	59-7/8	1521	20-3/4	527	37-7/16	951	30-7/16	773	23-11/16	602	19-1/16	484
12	300	14	360	63-13/16	1622	24	610	39-5/8	1006	34-3/8	873	27-5/16	694	19-1/16	484

1. Unit weights indicate Net Weight of valve in pounds at standard set pressure (0.5 oz./sq. in. pressure - 0.5 oz./sq. in. vacuum), does not include shipping crate or box. Add 20% for gross shipping weight (Domestic Only).

Key to Enardo 850/MVC Model Number

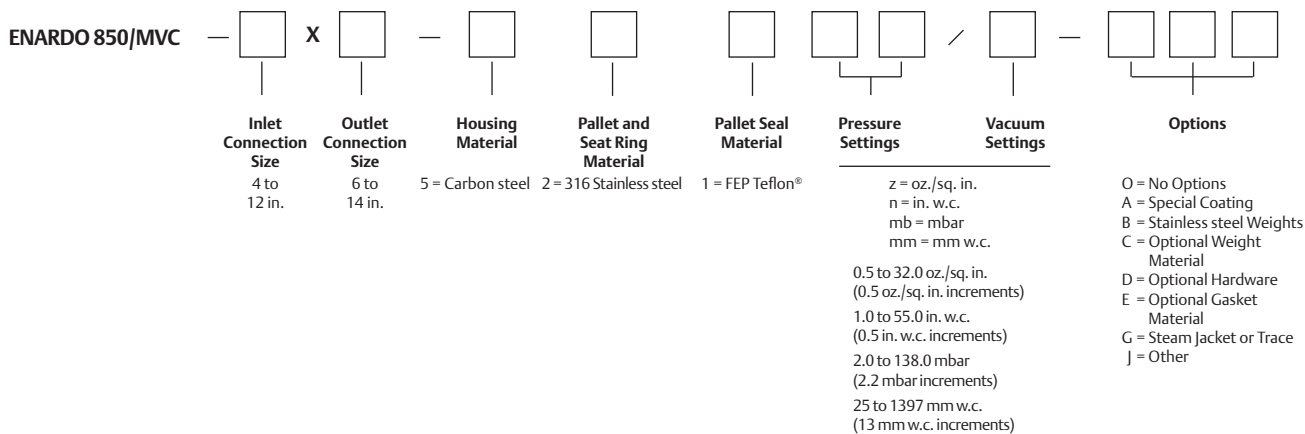

Example:

ENARDO 850/MVC — 4 X 6 — 5 2 1 z 16 / 8 — D E J

Indicates a pressure vacuum relief valve with 4 in. inlet and 6 in. outlet, ANSI 150 lb. raised face flange pattern connections, carbon steel housing, 316 Stainless steel pallet and seat ring and FEP Teflon® pallet seal. Pressure setting is 16 oz./sq. in. and the vacuum setting is 8 oz./sq. in. Standard options include stainless steel hardware, Teflon® gaskets and gooseneck outlet flange.

Teflon® is a mark owned by E. I. du Pont de Nemours and Company.

Marine Vapor Control System

Pressure Vacuum Relief Valve

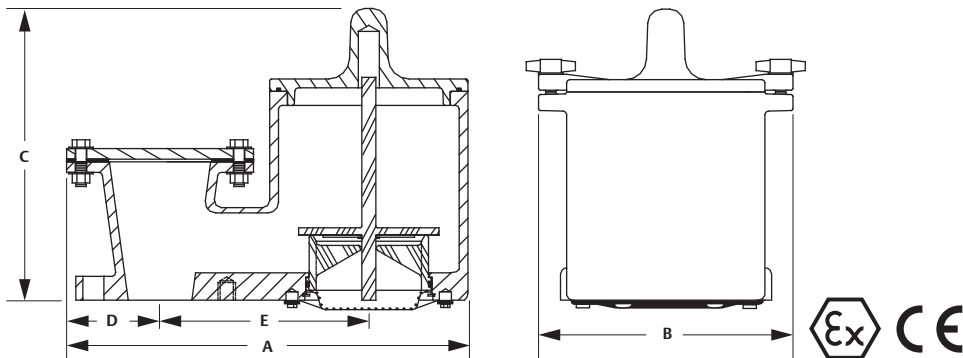

Figure 3. Enardo™ 952/MVC Dimensions

Table 2. Enardo 952/MVC Dimensions and Weights

INLET CONNECTION		A (OVERALL LENGTH)		B (OVERALL WIDTH)		C (OVERALL HEIGHT)		D (CL INLET)		E (CL I/O)	
In.	mm	In.	mm	In.	mm	In.	mm	In.	mm	In.	mm
4	100	19-1/8	486	11	279	13-7/8	352	7	178	9-13/16	249
6	150	20-1/4	514	11	279	13-7/8	352	7	178	10	254
8	200	33-1/8	841	16-1/8	410	20-1/2	521	11-1/2	292	17-1/8	435
10	250	33-1/4	845	16-1/8	410	20-1/2	521	11-1/2	292	17-1/8	435
12	300	37-3/8	949	20-3/4	527	23-1/4	591	11-1/2	292	19-1/16	484

1. Unit weights indicate Net Weight of valve in pounds at standard set pressure (0.5 oz./sq.in. vacuum), does not include shipping crate or box. Add 20% for gross shipping weight (Domestic Only).

Key to Enardo 952/MVC Model Number

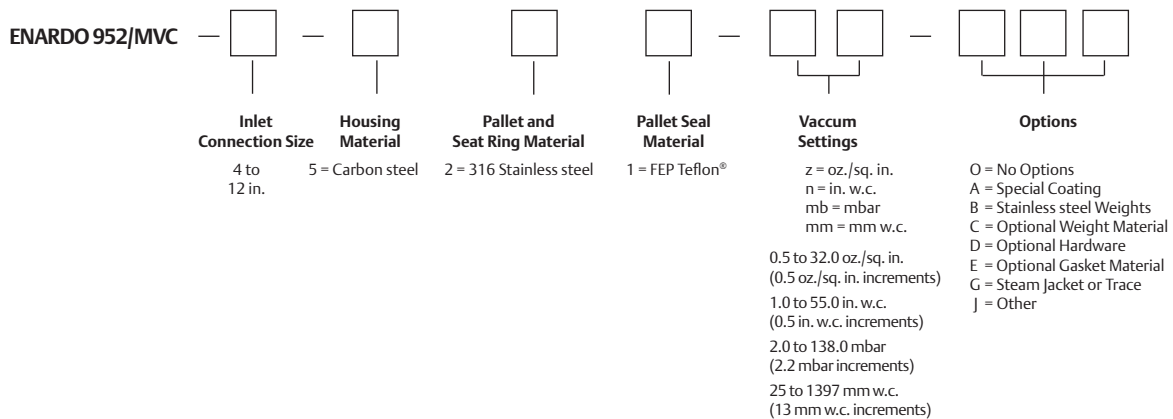

Example:



Indicates a vacuum relief valve with 4 in. inlet, ANSI 150 lb. raised face flange pattern connections, carbon steel housing, 316 Stainless steel pallet and seat ring and FEP Teflon® pallet seal. Vacuum setting is 10 in. w.c. standard options include stainless steel hardware and Teflon® gaskets.

Teflon® is a mark owned by E. I. du Pont de Nemours and Company.

Introduction

Enardo™ 860 spring loaded pressure relief valves are designed to handle higher pressure settings than standard dead weight loaded valves. The valve is designed for pressures up to 15 psig for tanks with higher maximum allowable working pressures. The Enardo 860 is part of high performance pressure vacuum relief valves. The Enardo 860 was designed with features to exceed the performance of standard valves on the market.

Enardo 860 pipe away design maintains a tight seal until system pressure or vacuum exceed the set pressure of the valve. When overpressure occurs the spring loaded pallet lifts, breaking the seal between the seat and pallet, allowing vapors to pass through the valve orifice and relieving the pressure or vacuum buildup. The valve reseals upon relief and remains sealed.

Available Sizes

2 to 6 in. / 50 to 150 mm

Valve Setting Range

Pressure

0.5 to 15.0 psi (0.5 psi increments)
 0.5 to 32.0 oz./sq. in. (0.5 oz increments)
 1.0 to 55.0 in. w.c. (0.5 in. increments)
 (2.0 to 138.0 mbar)

Vacuum

0.5 to 15.0 psi (0.5 psi increments)
 0.5 to 32.0 oz/sq. in. (0.5 oz increments)
 1.0 to 55.0 in. w.c. (0.5 in. increments)
 (2.0 to 138.0 mbar)

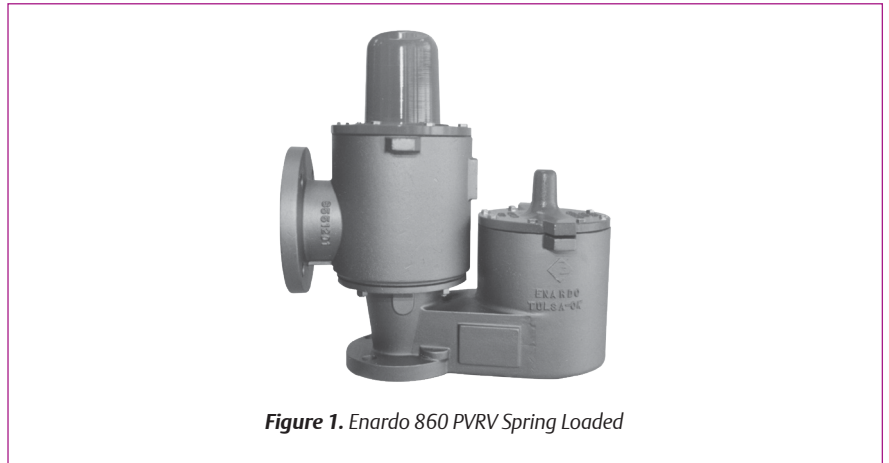

Figure 1. Enardo 860 PVRV Spring Loaded

Construction Materials

Housing

Aluminum
 Stainless steel
 Carbon steel

Seat/Pallet

Polyphenylene Sulfide (PPS)
 316 Stainless steel (standard above 5 psi)

Pallet Seal

Buna-N, FEP Teflon® or Viton®

Hardware

Zinc-plated carbon steel
 Stainless steel

Weight

Zinc-plated carbon steel
 Stainless steel
 Lead

Gasket

Buna-N, Teflon® or Viton®

Additional Technical Data

For more technical information, contact your local Sales Office or log on to:

www.enardo.com

Features

- **Advanced composite thermoplastic Polyphenylene Sulfide (PPS) materials for seat and trim provide superior resistance to corrosion, chemical attack, liquid and vapor adhesion, temperature extremes (-50 to 500°F) and sticking due to valve seat freeze.**
- **Enardo Saber® Guide valve system provides smooth valve stroke during operation and reduces valve wear.**
- **Leakage rate of no greater than 1 SCFH at 90% of setpoint.**
- **Excellent set point accuracy (+/-3%).**
- **Fully field replaceable pallet and seat assemblies.**
- **Available in ANSI, DIN and JIS flanges.**
- **EN 13463-1 and EN 13463-5 Certified.**

Teflon® and Viton® are marks owned by E. I. du Pont de Nemours and Company.

Enardo 860

PVRV Spring Loaded

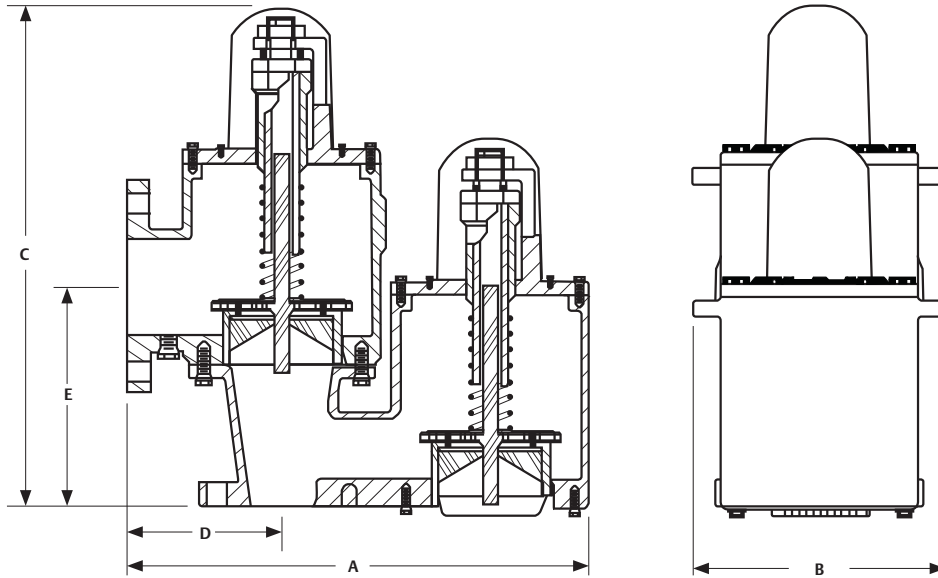

Figure 2. Enardo™ 860 Dimensions

Table 1. Enardo 860 Dimensions and Weight

MODEL	INLET CONNECTION		OUTLET CONNECTION		A OVERALL LENGTH		B OVERALL WIDTH		C OVERALL WIDTH		D CL Inlet		E CL I/O		ALUMINUM UNIT ⁽¹⁾		CARBON STEEL UNIT ⁽¹⁾		STAINLESS STEEL UNIT ⁽¹⁾	
	In.	mm	In.	mm	In.	mm	In.	mm	In.	mm	In.	mm	In.	mm	Lbs	kg	Lbs	kg	Lbs	kg
Enardo 860	2	50	3	80	11-7/8	302	1-3/4	44.5	8-3/4	222	14-1/4	362	7-1/2	191	33	15	85	39	92	42
	3	80	4	100	12	305	1-3/4	44.5	10-1/4	260	15-1/4	387	8	203	38	17	95	43	104	47
	4	100	6	150	14-1/2	368	1-3/4	44.5	11-5/8	295	17-1/4	438	9-1/2	241	66	30	153	69	166	75
	6	150	8	200	14-1/2	368	1-3/4	44.5	11-5/8	295	17-1/4	438	13	330	80	36	190	86	205	93

1. Unit weights indicate Net Weight of valve in pounds at standard set pressure (0.5 oz./sq. in. pressure and 0.5 oz./sq. in. vacuum), does not include shipping crate or box. Add 20% for gross shipping weight (Domestic Only).

Key to Enardo 860 Model Number

ENARDO 860 - X - - / -

Inlet Connection Size
2 to 6 in.

Outlet Connection Size
3 to 8 in.

Housing Material
1 = Aluminum
2 = Stainless steel
3 = Carbon steel

Pallet and Seat Ring Material
1 = Advanced Composite-Polyphenylene Sulfide (PPS)
2 = 316 Stainless steel
3 = Other

Pallet Seal Material
1 = FEP Teflon®
2 = Buna-N
3 = Viton®
4 = Other

Pressure Settings
p = psig
z = oz./sq. in.
n = in. w.c.
0.5 to 15.0 psi (0.5 psi increments)
0.5 to 32.0 oz./sq. in. (0.5 oz./sq. in. increments)
1.0 to 55.0 in. w.c. (0.5 in. w.c. increments)

Vacuum Settings
p = psig
z = oz./sq. in.
n = in. w.c.
0.5 to 15.0 psi (0.5 psi increments)
0.5 to 32.0 oz./sq. in. (0.5 oz./sq. in. increments)
1.0 to 55.0 in. w.c. (0.5 in. w.c. increments)

Options
O = No Options
A = Special Coating
B = Stainless steel Weights
C = Optional Weight Material
D = Optional Hardware
E = Optional Gasket Material
F = Optional Fiber-Reinforced Plastic (FRP) Resins
G = Steam Jacket or Trace
H = Other

Example:

ENARDO 860 - X - - / -

Indicates a Pipe-Away pressure vacuum relief valve with 2 in. inlet by 3 in. outlet, ANSI 150 lb. flat face flange pattern connections, aluminum housing, stainless steel pallet and seat ring and FEP Teflon® pallet seal. Pressure setting is 10 psig and vacuum setting is 6 oz./sq. in. Options include special external epoxy coating of valve.

Teflon® and Viton® are marks owned by E. I. du Pont de Nemours and Company.

Introduction

Enardo™ 960 spring loaded pressure relief valves are designed to handle higher pressure settings than standard dead weight loaded valves. The valve is designed for pressures up to 15 psig for tanks with higher maximum allowable working pressures.

Enardo 960 is part of high performance pressure vacuum relief valves. The Enardo 960 was designed with features to exceed the performance of standard valves on the market. Standard features include:

Enardo 960 vent-to-atmosphere design maintains a tight seal until system pressure or vacuum exceed the set pressure of the valve. When overpressure occurs the spring loaded pallet lifts, breaking the seal between the seat and pallet, allowing vapors to pass through the valve orifice and relieving the pressure or vacuum buildup. The valve reseals upon relief and remains sealed.

Available Sizes

2 to 6 in. / 50 to 150 mm

Valve Setting Range

Pressure

0.5 to 15.0 psi (0.5 psi increments)
0.5 to 32.0 oz./sq. in. (0.5 oz. increments)
1.0 to 55.0 in. w.c. (0.5 in. increments)
2.0 to 138.0 mbar

Vacuum

0.5 to 15.0 psi (0.5 psi increments)
0.5 to 32.0 oz./sq. in. (0.5 oz. increments)
1.0 to 55.0 in. w.c. (0.5 in. increments)
2.0 to 138.0 mbar



Figure 1. Enardo 960 High Performance PVRV Spring Loaded

Construction Materials

Housing

Aluminum
Stainless steel
Carbon steel

Seat/Pallet

Polyphenylene Sulfide (PPS)
316 Stainless steel (standard above 5 psi)

Pallet Seal

Buna-N, FEP Teflon® or Viton®

Hardware

Zinc-plated carbon steel
Stainless steel

Weight

Zinc-plated carbon steel
Stainless steel
Lead

Gasket

Buna-N, Teflon® or Viton®

Additional Technical Data

For more technical information, contact your local Sales Office or log on to:

www.enardo.com

Features

- **Advanced composite thermoplastic Polyphenylene Sulfide (PPS) materials for seat and trim provide superior resistance to corrosion, chemical attack, liquid and vapor adhesion, temperature extremes (-50 to 500°F) and sticking due to valve seat freeze.**
- **Enardo Saber® Guide valve system provides smooth valve stroke during operation and reduces valve wear.**
- **Exceeds the most stringent standards for allowable leakage (1 SCFH at 90% of setpoint per valve) and provides excellent set point accuracy (+/-3%).**
- **Fully field replaceable pallet and seat assemblies.**
- **Available in ANSI, DIN and JIS flanges.**
- **EN 13463-1 and EN 13463-5 Certified.**

Teflon® and Viton® are marks owned by E. I. du Pont de Nemours and Company.

Enardo 960

High Performance PVRV Spring Loaded

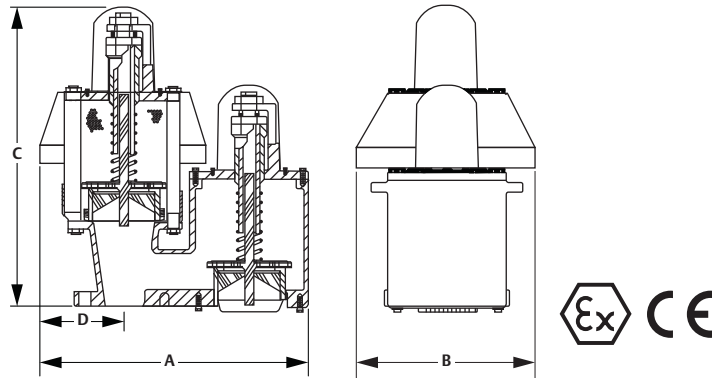

Figure 2. Enardo™ 960 Dimensions

Table 1. Enardo 960 Dimensions and Weight⁽¹⁾

INLET CONNECTION		A (OVERALL LENGTH)		B (OVERALL WIDTH)		C (OVERALL HEIGHT)		D (CL INLET)		WEIGHT (ALUMINUM)		WEIGHT (CARBON STEEL)		WEIGHT (STAINLESS STEEL)	
In.	mm	In.	mm	In.	mm	In.	mm	In.	mm	Lbs	kg	Lbs	kg	Lbs	kg
2	50	16	406	10	254	19-3/4	502	5	127	21	10	50	23	54	24
3	80	16	406	10	254	20-1/8	511	5	127	23	10	54	24	58	26
4	100	22-1/2	572	14	356	25-1/2	648	7	178	41	19	102	46	110	50
6	150	22-3/4	578	14	356	27-5/16	694	7	178	45	20	114	52	123	56

1. Unit weights indicate Net Weight of valve in pounds at standard set pressure (10.5 oz./sq. in. pressure and 0.5 oz./sq. in. vacuum), does not include shipping crate or box. Add 20% for gross shipping weight (Domestic Only).

Key to Enardo 960 Model Number

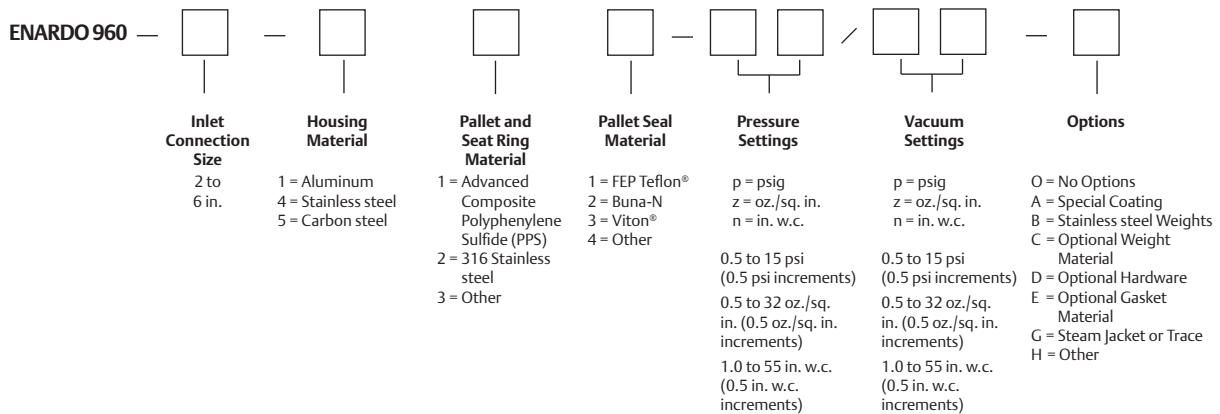

Example:



Indicates a vent-to-atmosphere pressure vacuum relief valve with 4 in. inlet, ANSI 150 lb. flat face flange pattern connections, aluminum housing, Advanced Composite Polyphenylene Sulfide (PPS) pallet and seat ring and Buna-N pallet seal. Pressure setting is 4 psi and vacuum setting is 6 in. w.c.

Teflon® and Viton® are marks owned by E. I. du Pont de Nemours and Company.

Introduction

Enardo™ 961 spring loaded pressure relief valves are designed to handle higher pressure settings than standard dead weight loaded valves. The valve is designed for pressures up to 15 psig / 1034 mbarg for tanks with higher maximum allowable working pressures.

Enardo 961 is part of high performance pressure vacuum relief valves. The Enardo 961 was designed with features to exceed the performance of standard valves on the market.

Enardo 961 vent-to-atmosphere design maintains a tight seal until system pressure or vacuum exceed the set pressure of the valve. When overpressure occurs the spring loaded pallet lifts, breaking the seal between the seat and pallet, allowing vapors to pass through the valve orifice and relieving the pressure buildup. The valve reseals upon relief and remains sealed.

Available Sizes

2 to 6 in. / 50 to 150 mm

Valve Setting Range

Pressure Setting

Maximum 14.99 psi / 1034 mbarg

Construction Materials

Housing

Aluminum
Stainless steel
Carbon steel

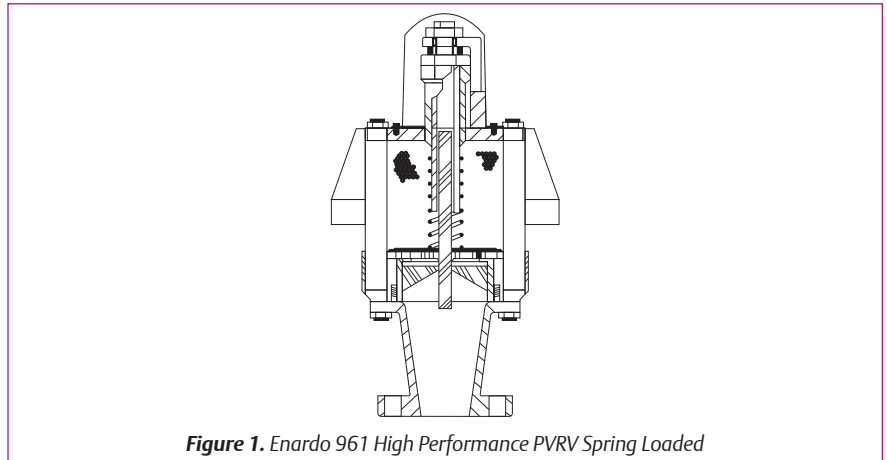

Figure 1. Enardo 961 High Performance PVRV Spring Loaded

Construction Materials (continued)

Seat/Pallet

Polyphenylene Sulfide (PPS)
(maximum 5 psig / 345 mbarg)

316 Stainless steel
(standard above 5 psig / 345 mbarg)

Pallet Seal

Nitrile (NBR)
Fluorinated Ethylene
Propylene (FEP) Teflon®
Fluorocarbon (FKM) (Viton®)

Body/Seat/Lid Seal

Nitrile (NBR)
Fluorinated Ethylene
Propylene (FEP) Teflon®
Fluorocarbon (FKM) (Viton®)

Additional Technical Data

For more technical information, contact your local Sales Office or log on to:

www.Enardo.com

Features

- **Advanced composite thermoplastic Polyphenylene Sulfide (PPS) materials for seat and trim provide superior resistance to corrosion, chemical attack, liquid and vapor adhesion, temperature extremes (-50 to 500°F / -46 to 10°C) and sticking due to valve seat freeze.**
- **Enardo Saber® Guide valve system provides smooth valve stroke during operation and reduces valve wear.**
- **Exceeds the most stringent standards for allowable leakage (1 SCFH at 90% of setpoint per valve) and provides excellent set point accuracy (+/-3%).**
- **Fully field replaceable pallet and seat assemblies.**
- **Available in ANSI, DIN and JIS flanges.**
- **EN 13463-1 and EN 13463-5 certified.**

Teflon® and Viton® are marks owned by E. I. du Pont de Nemours and Co.

Emergency Vents and Free Vents

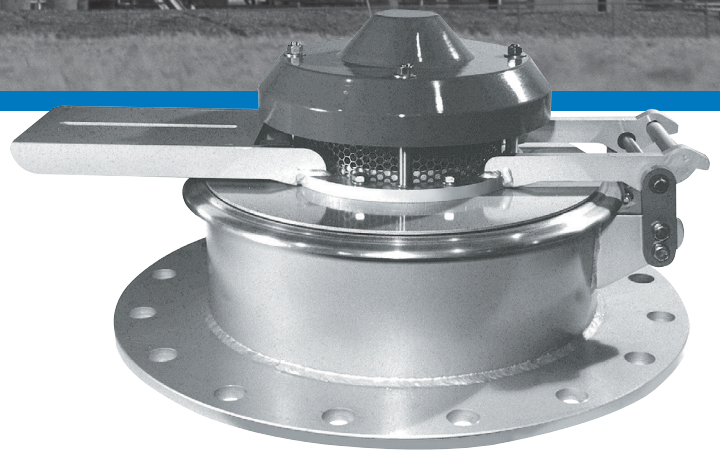

Emergency Pressure Relief Vent Design and Application Data Sheet

Emergency Vent and Free Vent

Customer _____

Contact _____

Address _____

Project Reference _____

Date _____

Telephone _____

Fax _____

Email _____

Application Data

Design Per API 2000 Customer Supplied Capacity

Tank Capacity _____ Tank Type Vertical Horizontal Spheroid

Tank Dimensions: Diameter/Length _____ / _____

Tank Design Pressure/Vacuum (MAWP/MAWV) _____ / _____

Tank Insulation Yes No Thickness _____

Temperature (Normal/Maximum) _____ / _____ Pressure (Normal/Maximum) _____ / _____

Pressure Setting (in. w.c. / oz./sq. in.) _____ / _____ Vacuum Setting (in. w.c. / oz./sq. in.) _____ / _____

Maximum Back Pressure _____

Calculated Total Outbreathing _____ Calculated Total Inbreathing _____

Design Data

Enardo™ 2000 Emergency Pressure Relief Vent

Enardo 2500 Emergency Pressure Relief Vent - With Vacuum

Size: Inlet _____ in.

Flange Pressure Rating: ANSI 150# R.F. (**standard**) DIN Other _____

API JIS

Materials:

Base and Hinge Arm _____ Disk Cover _____

Weight Material _____ Pallet Seal _____

Options:

Coating/Special Paint _____

Special Gasketing _____

Other Options _____

Additional Information: _____

Introduction

Enardo™ 2000 Series emergency relief vents are designed to provide an opening for storage tanks when exposed to overpressure that are not handled by standard tank vents. These vents provide the capacity to meet API standard 2000 for emergency venting due to fire exposure when properly sized. These vents also provide quick easy access for tank inspection and maintenance.

Emergency pressure relief vents provide pressure relief only. Vacuum relief must be supplied by normal venting devices or an Enardo 2500 Series emergency relief vent with vacuum.

When excessive pressure builds within the storage tank the Enardo 2000 Series emergency pressure relief vent hinged cover begins to open at the predetermined set pressure, relieving excess pressure. When overpressure has dissipated, the cover reseats onto the base. The hinge mechanism prevents misalignment and provides an accurate reseal.

Optional Remote Monitoring provides immediate indication of open emergency vent.

Available Sizes

ANSI: 4, 8, 12, 16, 18, 20 and 24 in. / 100, 200, 300, 400, 460, 500 and 600 mm

API: 8, 20 and 24 in. / 200, 500 and 600 mm

Vent Setting Range

Pressure

2.0 to 32.0 oz./sq. in. (0.5 increments)

3.5 to 55.0 in. w.c. (1.0 increments)

8.6 to 138 mbar (2.2 mbar increments)

Vacuum

N/A

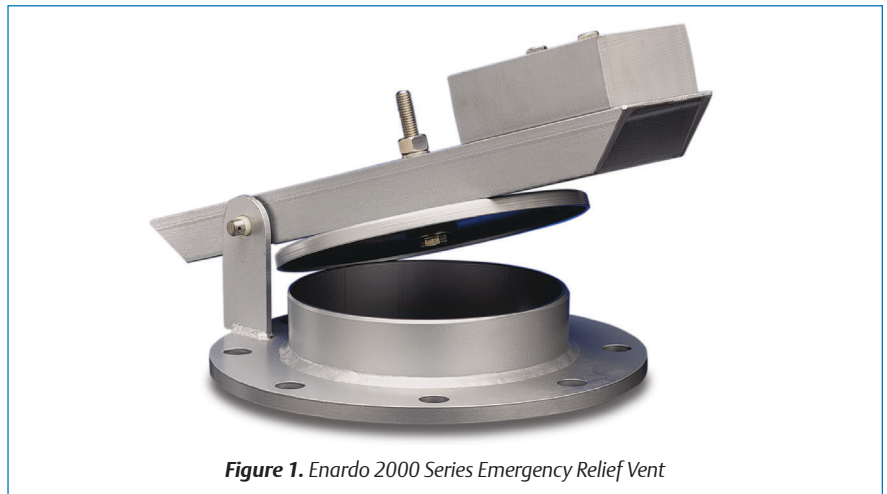

Figure 1. Enardo 2000 Series Emergency Relief Vent

Construction Materials

Base

Carbon Steel
304 Stainless steel
316 Stainless steel

Arm

Carbon Steel
304 Stainless steel
316 Stainless steel

Disk

Aluminum
304 Stainless steel
316 Stainless steel

Seal

Buna-N, FEP Teflon® or Viton®

Seal Support

Aluminum
304 Stainless steel
316 Stainless steel

Additional Technical Data

For more technical information, contact your local Sales Office or log on to:

www.enardo.com

Features

- Advanced seal technology exceeds the most stringent of industrial standards for allowable leakage (1 SCFH at 90% set point) and provides excellent set point accuracy (+/- 3%).
- All components are field replaceable, including pallet seal without the need for special tools or complex procedures.
- Every Enardo 2000 Series vent is factory inspected and leak checked and certified.
- Corrosion-resistant coatings are available for even the most corrosive of applications.
- Certified flow capacity curves are available for the full product size range.
- Available in API, ANSI, DIN and JIS flanges.
- EN 13463-1 and EN 13463-5 Certified.
- Optional Remote Monitoring.

Teflon® and Viton® are marks owned by E. I. du Pont de Nemours and Company.

Enardo 2000 Series

Emergency Relief Vent

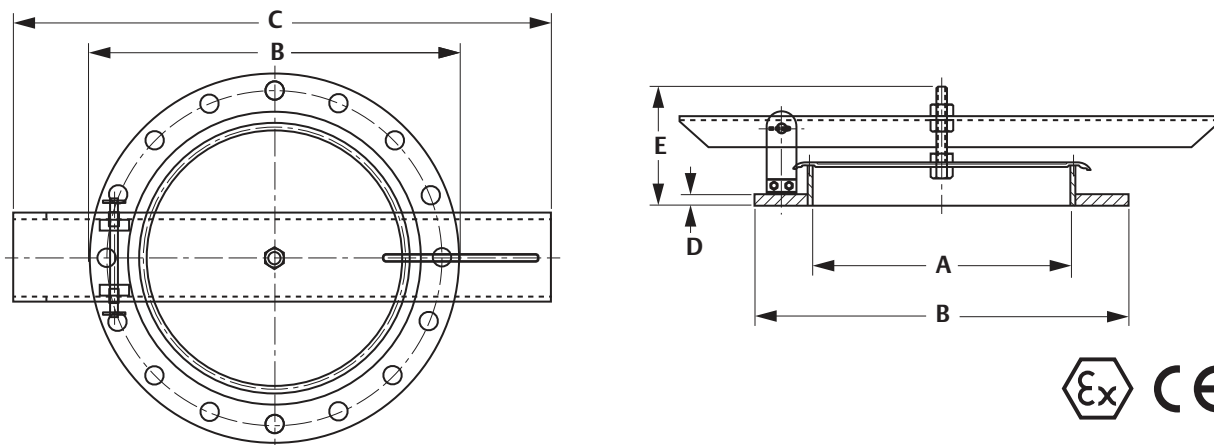

Figure 2. Enardo™ 2000 Series Dimensions

Table 1. Enardo 2000 Series Dimensions

MODEL	A (SIZE)		B1 (ANSI FLANGE O.D.)		B2 (API FLANGE O.D.)		C (OVERALL LENGTH)		D (FLANGE THICKNESS)		E (HEIGHT)		WEIGHT (CARBON STEEL) ⁽¹⁾		WEIGHT (STAINLESS STEEL) ⁽¹⁾	
	In.	mm	In.	mm	In.	mm	In.	mm	In.	mm	In.	mm	Lbs	kg	Lbs	kg
Enardo 2004	4	100	9	229	----	----	14	356	1/2	13	4-3/4	121	14	6	14	6
Enardo 2008	8	200	13-1/2	343	13-1/2	343	21	533	1/2	13	6-1/2	165	28	13	29	13
Enardo 2012	12-1/4	310	19	483	----	----	22	559	1/2	13	6-1/2	165	42	19	43	20
Enardo 2016	15-1/4	390	23-1/2	597	----	----	29	737	1/2	13	6-1/2	165	94	43	97	44
Enardo 2018	17-1/2	445	25	635	----	----	36	914	3/4	19	6-3/4	171	110	50	118	54
Enardo 2020	19-1/4	490	27-1/2	699	26	660	38-1/4	972	3/4	19	6-3/4	171	119	54	127	58
Enardo 2024	23-1/4	590	32	813	30	762	41	1041	3/4	19	6-3/4	171	176	80	186	84

1. Unit weights indicate Net Weight of valve at standard set pressure (2.0 oz./sq.in. pressure), does not include shipping crate or box. Add 20% for gross shipping weight (Domestic Only). Pressure settings above the standard will increase total unit weight - consult factory for more information.

Selection Guide to Enardo 2000 Series

ENARDO 2 0 1 2 - 2 1 N - 1 - Z 2 - 4

Series
2 = Carbon Steel
3 = 304 Stainless steel
4 = 316 Stainless steel
5 = Exotic

Connection Size
1 = Aluminum
3 = 304 Stainless steel
4 = 316 Stainless steel
5 = Exotic

Base and Arm
1 = Aluminum
3 = 304 Stainless steel
4 = 316 Stainless steel
5 = Exotic

Disk Cover
T = Teflon®
N = Buna-N
V = Viton®
X = Special

Gasket
1 = ANSI
2 = API

Bolt Pattern
n = in. w.c.
z = oz./sq. in.
2.0. to 32.0 oz./sq. in. (0.5 oz./sq. in. increments)
3.5 to 55.0 in. w.c. (1.0 in. w.c. increments)
8.6 to 138 mbar (2.2 mbar increments)

Pressure Settings
1 = Special Coating
2 = Optional Hardware
3 = Other
4 = Smart Wireless Monitoring

Options

Example:

ENARDO 2 0 1 2 - 2 1 N - 1 - Z 2 - 4

Indicates a 12 in. Emergency Pressure Relief Vent with a Carbon steel base, an aluminum lid with a Buna-N gasket, a ANSI 150 lb. bolting pattern, with relief pressure of 24 oz./sq.in. and Smart Wireless Monitoring.

Teflon® and Viton® are marks owned by E. I. du Pont de Nemours and Company.

Introduction

The Wireless Monitoring Option is available for order with EPRV Enardo™ 2000. This option allows the remote sensing of the open or closed position of the vent which enables immediate response to prevent problems related to safety, emissions and the quality of tank contents.

Application

Model

Enardo 2000

Sizes

4, 8, 12, 16, 18, 20 and 24 in. /
100, 200, 300, 400, 460, 500 and 600 mm

Transmitter Sample Rate

Once/8 seconds

Additional Technical Data

For more technical information, contact your local Sales Office or log on to:

www.enardo.com



Figure 1. Wireless Monitoring Option for Enardo 2000

Table 1. Ordering Option Code

DESCRIPTION	OPTION CODE
Smart Wireless Monitoring	4

Features

- **Wireless transmitter, proximity sensor and magnetic target.**
- **Proximity sensor allows the transmitter to detect the open or closed position of the vent.**
- **Signals received by transmitter can be sent to a control room via a gateway.**
- **Fully-tested and integrated design.**

Teflon® and Viton® are marks owned by E. I. du Pont de Nemours and Company.

Enardo 2100 Series

Emergency Relief Vent

Introduction

Enardo™ 2100 Series emergency relief vents are designed to provide an emergency pressure relief opening for storage tanks when exposed to overpressure that are not handled by standard tank vents. These vents provide the capacity to meet API standard 2000 for emergency venting due to fire exposure when properly sized. Quick and easy access for tank inspection and maintenance is also provided.

Emergency pressure relief vent provides pressure relief only. Vacuum relief must be supplied by normal venting devices or an Enardo 2500 Series emergency relief vent with vacuum.

When excessive pressure builds within the storage tank the Enardo 2100 Series emergency pressure relief vent lid begins to open at the predetermined set pressure, relieving excess pressure. When the overpressure has dissipated, the cover reseats onto the base. Guides prevent misalignment and provide an accurate reseal.

Available Sizes

16, 20 and 24 in. / 400, 500 and 600 mm
API 20 and 24 in. / 500 and 600 mm

Vent Setting Range

Pressure

Up to 8.0 oz./sq. in.
(0.5 oz./sq. in. increments)
Up to 14.0 in. w.c.
(1.0 in. w.c. increments)
Up to 3632 mm w.c.
(22.4 mm w.c. increments)
Up to 34.0 mbar
(2.2 mbar increments)

See Table 1 for minimum settings

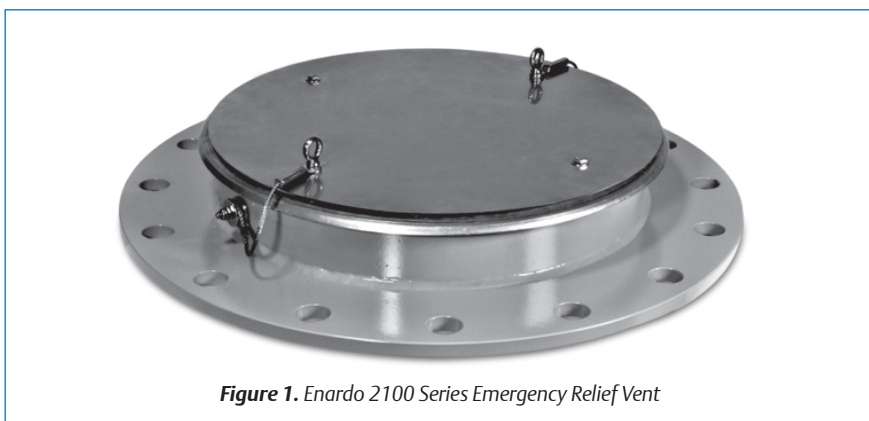

Figure 1. Enardo 2100 Series Emergency Relief Vent

Vent Setting Range (continued)

Vacuum

N/A

Construction Materials

Base

Carbon Steel
304 Stainless steel
316 Stainless steel

Lid

Aluminum
304 Stainless steel
316 Stainless steel

Seal

Buna-N, FEP Teflon® or Viton®

Seal Support

Aluminum
304 Stainless steel
316 Stainless steel

Additional Technical Data

For more technical information, contact your local Sales Office or log on to:

www.enardo.com

Features

- Advanced seal technology exceeds the most stringent of industrial standards for allowable leakage (1 SCFH at 90% set point) and provides excellent set point accuracy (+/- 3%).
- All components are field replaceable, including pallet seal without the need for special tools or complex procedures.
- Every Enardo 2100 Series vent is factory inspected and leak checked and certified.
- Corrosion-resistant coatings are available for even the most corrosive of applications.
- Certified flow capacity curves are available for the full product size range.
- Available in API, ANSI, DIN and JIS flanges.

Table 1. Minimum Settings Enardo 2100 Series

SIZE		ALUMINUM	CARBON STEEL/ STAINLESS STEEL	ALUMINUM	CARBON STEEL/ STAINLESS STEEL	ALUMINUM	CARBON STEEL/ STAINLESS STEEL	ALUMINUM	CARBON STEEL/ STAINLESS STEEL
In.	mm	oz./sq. in.		In. w.c.		mbar		mm w.c.	
16	400	0.7	1.3	1.2	2.2	3	5.6	30	56
20	500	0.7	1.3	1.2	2.2	3	5.6	30	56
24	600	0.8	1.3	1.4	2.2	3.4	5.6	36	56

Teflon® and Viton® are marks owned by E. I. du Pont de Nemours and Company.

Enardo 2100 Series

Emergency Relief Vent

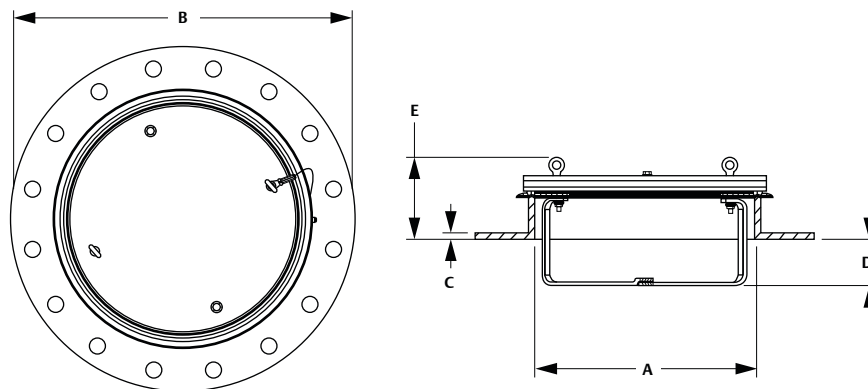

Figure 2. Enardo™ 2100 Series Dimensions

Table 2. Enardo 2100 Series Dimensions

MODEL	A (SIZE)		B1 (ANSI FLANGE O.D.)		B2 (API FLANGE O.D.)		C (FLANGE THICKNESS)		D (HEIGHT)		E (HEIGHT)		WEIGHT (ALUMINUM/CARBON STEEL) ⁽¹⁾		WEIGHT (STAINLESS STEEL) ⁽¹⁾	
	In.	mm	In.	mm	In.	mm	In.	mm	In.	mm	In.	mm	Lbs	kg	Lbs	kg
Enardo 2116	15.3	387	23.5	597	20.9	530	0.50	13	3.1	79	6.3	160	56	25	62	28
Enardo 2120	19.3	489	27.5	699	26.0	660	0.75	19	4.1	104	6.3	160	84	38	98	44
Enardo 2124	23.3	591	32.0	813	30.0	762	1.00	25	5.2	132	6.3	160	134	61	149	67

1. Unit weights indicate Net Weight of valve at minimum set pressure and do not include shipping crate or box. Add 20% for gross shipping weight (Domestic Only). Pressure settings above the standard will increase total unit weight - consult factory for more information. Lids of less than 100 lbs / 45 kg in weight will be tethered to the base with one lanyard. Lids weighing 100 lbs / 45 kg or more will be restrained with two lanyards.

Selection Guide to Enardo 2100 Series

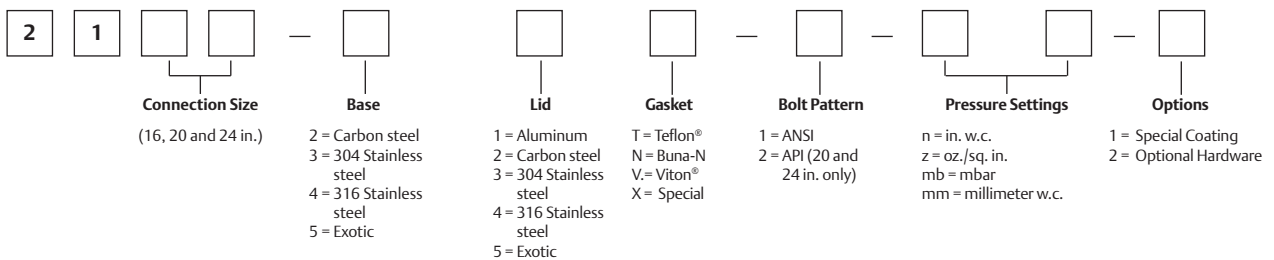

Example:



Indicates a 20 in. Emergency Pressure Relief Vent with a Carbon steel base, an aluminum lid with a Buna-N gasket, an ANSI 150 lb. bolting pattern, with relief pressure of 2 oz./sq. in.

Teflon® and Viton® are marks owned by E. I. du Pont de Nemours and Company.

Enardo 2500 Series

Emergency Relief Vent with Vacuum

Introduction

Enardo™ 2500 Series emergency relief vents are designed to provide an emergency pressure relief opening for storage tanks when exposed to overpressure that are not handled by standard tank vents. These vents provide the capacity to meet API standard 2000 for emergency venting due to fire exposure when properly sized and provides high capacity vacuum flow for emergency pump-out of product. These vents also provide quick easy access for tank inspection and maintenance.

When excessive pressure builds within the storage tank the Enardo 2500 Series Emergency Pressure Relief Vent's hinged cover begins to open at the predetermined set pressure, relieving excess pressure. When overpressure has dissipated, the cover reseats onto the base. The hinge mechanism prevents misalignment and provides an accurate reseal. When excessive vacuum builds within the storage tank, the spring loaded pallet lifts, breaking the seal between the seat and pallet, allowing air to pass through the valve orifice relieving the vacuum buildup. The vacuum valve reseals upon relief and remains sealed.

Available Sizes

ANSI: 16, 20 and 24 in. /
400, 500 and 600 mm

API: 20 and 24 in. / 500 and 600 mm

Vent Setting Range

Pressure

4.0 to 16.0 oz./sq. in.
(0.5 oz./sq. in. increments)
7.0 to 27.0 in. w.c.

(0.5 oz./sq.in. increments)
17.4 to 67.2 mbar
(2.2 mbar increments)

Vacuum

0.5, 0.75, 1.0 and 2.0 oz./sq. in.

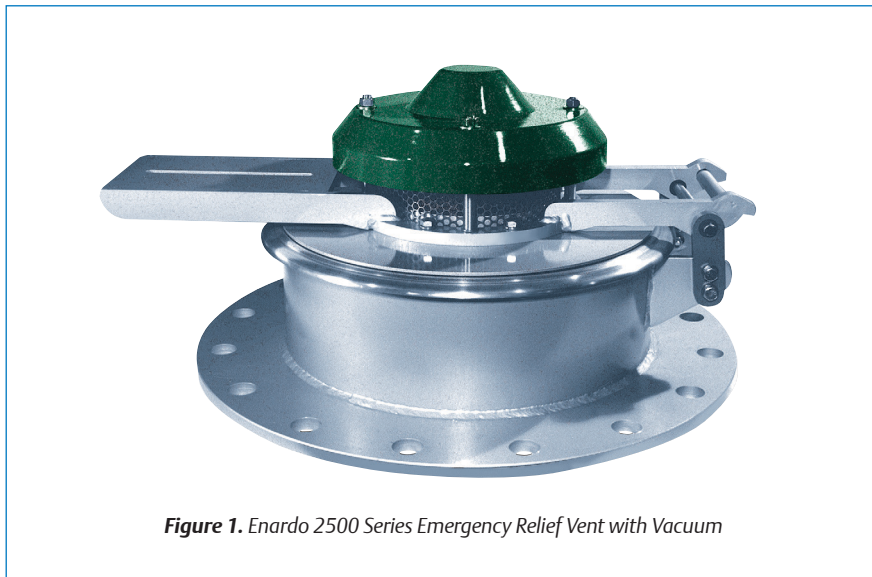

Figure 1. Enardo 2500 Series Emergency Relief Vent with Vacuum

Construction Materials

Base, Arm and Hood

Carbon Steel
304 Stainless steel
316 Stainless steel

Disk and Seal Support

Aluminum
316 Stainless steel

Seal

Buna-N, FEP Teflon® or Viton®

Vacuum Spring

302 Stainless steel

Vacuum Pallet

Advanced Composite-Polyphenylene
Sulfide(PPS)
316 Stainless steel

Vacuum Seat

Advanced Composite-Polyphenylene
Sulfide (PPS)
316 Stainless steel

Additional Technical Data

For more technical information, contact
your local Sales Office or log on to:

www.enardo.com

Features

- **Advanced seal technology exceeds the most stringent of industrial standards for allowable leakage (1 SCFH at 90% set point) and provides excellent set point accuracy (+/- 3%).**
- **Every Enardo 2500 Series vent is factory inspected and leak checked and certified.**
- **Corrosion-resistant coatings are available for even the most corrosive of applications.**
- **Certified flow capacity curves are available for the full product size range.**
- **Available in API, ANSI, DIN and JIS flanges.**
- **EN 13463-1 and EN 13463-5 Certified.**

Teflon® and Viton® are marks owned by E. I. du Pont de Nemours and Company.

Enardo 2500 Series

Emergency Relief Vent with Vacuum

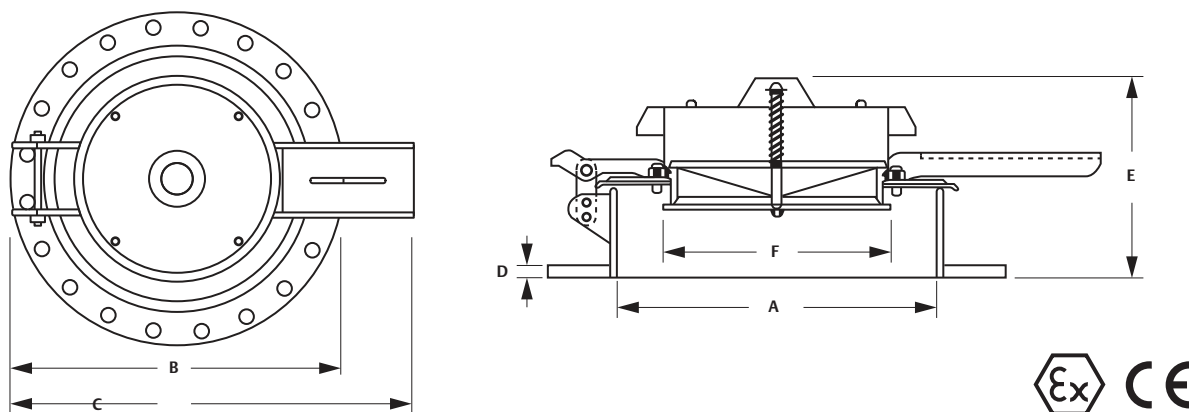

Figure 2. Enardo™ 2500 Series Dimensions

Table 2. Enardo 2500 Series Dimensions

MODEL	A (SIZE)		B1 (ANSI FLANGE O.D.)		B2 (API FLANGE O.D.)		C (OVERALL LENGTH)		D (FLANGE THICKNESS)		E (HEIGHT)		F (VACUUM PORT)		WEIGHT (CARBON STEEL) ⁽¹⁾		WEIGHT (STAINLESS STEEL) ⁽¹⁾	
	In.	mm	In.	mm	In.	mm	In.	mm	In.	mm	In.	mm	In.	mm	Lbs	kg	Lbs	kg
Enardo 2516	15-1/4	390	23-1/2	597	----	----	26-1/2	13	1/2	13	12-1/2	318	6-3/8	162	90	41	100	45
Enardo 2520	19-1/4	490	27-1/2	699	26	660	33-1/2	19	3/4	19	13-1/2	343	12	305	135	61	145	66
Enardo 2524	23-1/4	590	32	813	30	762	36-1/4	25	1	25	13-1/2	343	12	305	195	88	210	95

1. Unit weights indicate Net Weight of valve at standard set pressure (2.0 oz./sq. in. pressure), does not include shipping crate or box. Add 20% for gross shipping weight (Domestic Only). Pressure settings above the standard will increase total unit weight - consult factory for more information.

Selection Guide to Enardo 2500 Series

ENARDO	<input type="text" value="2"/>	<input type="text" value="5"/>	<input type="text" value="1"/>	<input type="text" value="6"/>	-	<input type="text" value="1"/>	<input type="text" value="2"/>	<input type="text" value="1"/>	<input type="text" value="T"/>	-	<input type="text" value="1"/>	-	<input type="text" value="Z"/>	<input type="text" value="8"/>	/	<input type="text" value=".5"/>	-	<input type="text" value="1"/>
	Series	Connection Size	Base, Arm and Hood	Disk and Seal Support		Vacuum Pallet and Seat	Gasket Seal	Bolt Pattern	Pressure Settings	Vacuum Settings	Options							
		16, 20 and 24 in.	1 = Carbon steel 2 = 304 Stainless steel 3 = 316 Stainless steel 4 = Exotic	1 = Aluminum 2 = 316 Stainless steel 3 = Exotic		1 = Polyphenylene Sulfide (PPS) 2 = 316 Stainless steel 3 = Exotic	T = Teflon® N = Buna-N V = Viton® X = Special	1 = ANSI 2 = API	n = in. w.c. z = oz./sq. in. 4.0 to 16.0 oz./sq. in. (0.5 oz./sq. in. increments) 7.0 to 27.0 in. w.c. (0.5 in. w.c. increments) 17.4 to 67.2 mbar (2.2 mbar increments)	0.5, 0.75, 1.0 or 2.0 oz./sq.in.	1 = Special Coating 2 = Optional Hardware 3 = Other							

Example:

ENARDO - - - / -

Indicates a 16 in. Emergency Pressure Relief Vent with Vacuum, carbon steel base, arm and hood, 316 Stainless steel disk and seal support, Polyphenylene Sulfide (PPS) vacuum pallet and seat, Teflon® pressure and vacuum seals, ANSI flange bolt pattern with 8 oz./sq.in. pressure setting and 0.5 oz./sq.in. vacuum setting. Option includes special coating.

Teflon® and Viton® are marks owned by E. I. du Pont de Nemours and Company.

Enardo 4000 and Enardo 4100

Free Vent

Introduction

Enardo™ 4000 and Enardo 4100 free vents are designed to be used on tanks containing non-volatile liquids. Free vents offer efficient flow capacity to protect the tank from positive or negative overpressure. They allow vapors to flow freely in and out of the storage tank.

Enardo 4000 and Enardo 4100 are designed to protect against rain, dirt, insects and other foreign matter from entering the vent.

Available in aluminum, carbon steel and stainless steel.

Model Numbers

Enardo 4000 and Enardo 4100

Vent Flange Sizes

2, 3, 4, 6, 8, 10 and 12 in. /
50, 80, 100, 150, 200, 250 and 300 mm

Construction Materials

Aluminum, Carbon steel, 304 Stainless steel, 316 Stainless steel, Special

Additional Technical Data

For more technical information, contact your local Sales Office or log on to:

www.enardo.com

Features

- Free Vents are built of corrosion resistant materials. A wire mesh screen prevents foreign matter from entering the tank or pipe opening.
- 150 lb. flange connections for quick and easy installation.
- As with all products, every Free Vent is factory inspected to meet all critical requirements and special needs.
- Rugged forged design provides years of trouble free service life.
- Available in API, ANSI, DIN and JIS flanges.

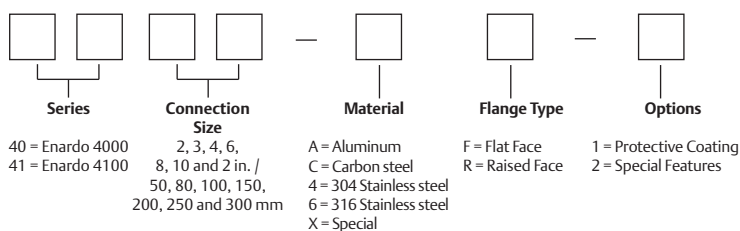

Figure 1. Enardo 4000



Figure 2. Enardo 4100

Key to Enardo 4000 and Enardo 4100 Model Number



Example:



Indicates a Free Vent with a 4 in. ANSI 150 lb raised face flange connection made with carbon steel materials.

Teflon® and Viton® are marks owned by E. I. du Pont de Nemours and Company.

Enardo 4000 and Enardo 4100

Free Vent

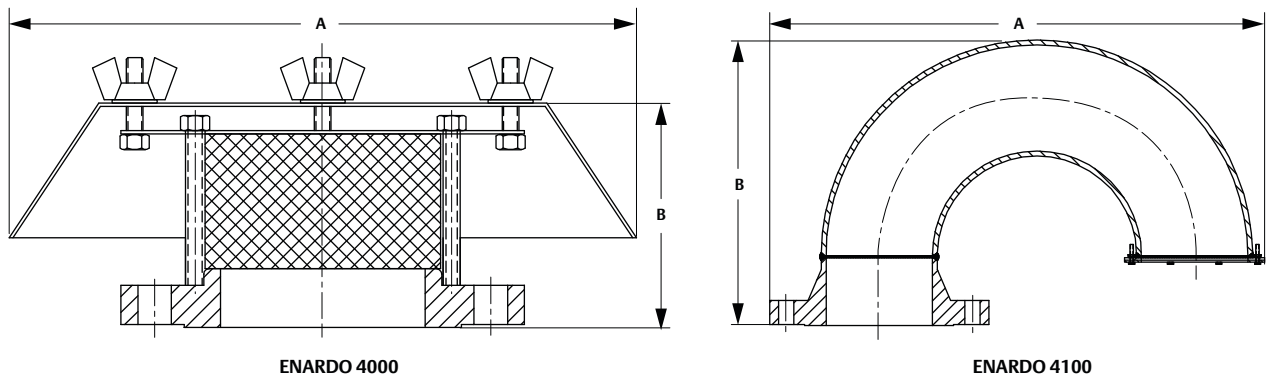

Figure 3. Enardo™ 4000 and Enardo 4100 Dimensions

Table 1. Enardo 4000 Dimensions and Weights⁽¹⁾

150 LB. FLANGE SIZE		A (WIDTH)		B (HEIGHT)		APPROXIMATE SHIPPING WIEGHT	
In.	mm	In.	mm	In.	mm	Lbs	kg
2	50	9	229	3-1/4	83	11	5
3	80	9	229	3-1/4	83	14	6.4
4	100	16-1/2	419	5	127	18	8
6	150	16-1/2	419	5	127	28	13
8	200	24-1/2	662	6-9/16	167	42	19
10	250	24-1/2	662	6-9/16	167	60	27
12	300	24-1/2	662	6-9/16	167	95	43

1. Larger sizes are available on special order.

Table 2. Enardo 4100 Dimensions and Weights⁽¹⁾

150 LB. FLANGE SIZE		A (WIDTH)		B (HEIGHT)		APPROXIMATE SHIPPING WIEGHT	
In.	mm	In.	mm	In.	mm	Lbs	kg
2	50	11	279	6	170	8	4
3	80	15-1/4	387	9	229	20	9
4	100	19-1/2	495	11-1/4	286	35	16
6	150	27-1/2	699	15-13/16	402	70	32
8	200	35-3/4	908	20-5/16	516	135	61
10	250	44	1118	24-3/8	619	235	107
12	300	52-1/2	1334	27-7/8	708	350	159

1. Larger sizes are available on special order.

NOTES:

Gauge and Thief Hatches



Gauges and Thief Hatches

Introduction

Thief Hatches are divided into two categories:

- Dead Weight Series
- Spring-Loaded Series

Dead Weight Series

Dead Weight Thief Hatches are generally used on low pressure, steel and fiberglass tanks. They are available with 1, 2, 4 or 6 oz./sq. in. pressure settings and have a standard 4/10 oz./sq. in. vacuum relief. Round base, dead weight hatches have an API standard 10-3/8 in. bolt circle for a nominal 8 in. tank opening.

Oblong base units have a 10-3/8 by 20-3/8 in. API bolt pattern for a nominal 8 by 18 in. tank opening. A thief shelf will be furnished as standard equipment on all oblong base hatches. The oblong base hatch is not recommended for tanks with decks heavier than 10-gauge metal since a vapor tight installation is less likely to be achieved.

Spring-loaded Series

Spring-Loaded Thief Hatches are generally used on low pressure steel and fiberglass tanks. They are available in 2, 4, 6, 8, 12, 16, 24 or 32 oz./sq. in. pressure settings and have a standard 4/10 oz./sq. in. vacuum relief. Spring-loaded hatches have a round base with an API standard 10-3/8 in. bolt circle for a nominal 8 in. tank opening. Models designated by the letter "L" will have a long basin which acts as the thief shelf.

Bleeder Models

Thief Hatches having the bleeder attachment are designed to manually pre-release tank pressure which eliminates the spray that would otherwise be discharged when the hatch cover is opened. Bleeder attachments are recommended for tanks with pressures in excess of 4 oz./sq. in. They are designated by the letter "B" in the thief hatch model number.

Envelope Pressure Gaskets

Envelope Gaskets are used on all Enardo 660 spring-loaded type hatches. As depicted in the accompanying illustrations (next page), tiny spacers are situated evenly around the inner surfaces of the gasket resting against the center pressure disk.

These spacers are designed to hold the gasket away from the lower metal surface. All tank pressure is therefore exerted against the inner surface of the gasket, causing the gasket to be pressed against the seat with a wrap-around contact that creates a positive seal with the machined valve seat. The gasket fits tight around the machined outer edge of the disk and will effectively hold pressures in excess of 32 ounces with minimal leakage.

While conventional flat gaskets do not seal tightly and constantly leak vapor pressure, the Envelope Pressure Gasket maintains a relatively high pressure differential around the outer rim of the valve seat to effectively maintain pressure levels.

How the Envelope Gasket Works



Pressure created within the tank energizes the Envelope Gasket as shown above left, forcing it down around the outer edge of the seat to form a wide contact area. By contrast, the conventional flat gasket maintains only "line" contact with its seat.



As tank pressure mounts, it forces the thin, flat gasket of the conventional hatch to lift off its seat. The Envelope Gasket, on the other hand, continues to keep its seat as the hatch assembly rises.



When the rated pressure of the valve has been reached, the disk with the envelope gasket snaps back into its original shape. The valve has attained an immediate full-open, creating a sudden release of pressure blowing the seat and gasket clean.



As tank pressures fall, the disk and envelope gasket falls into position against the seat, once again to create a tight seal.

In contrast, the gasket of the conventional hatch takes longer to recover its seat. As a result, a metering action occurs which prevents the valve from seating firmly and from holding tank pressures effectively.

Hatch Maintenance

Hatches will provide long, trouble-free operation if properly maintained. Pressure and vacuum seats, as well as disks, should be wiped clean each time the tank is thieved.

Sour Gas Design (Plastic Trim)

For adaptation to sour gas applications, all Thief Hatches are available with a plastic trim kit (PT) which includes a plastic seat and aluminum vacuum disk with Fluorocarbon (FKM) gaskets. In the spring-loaded series, springs are wound with corrosive-resistant Inconel® wire. When ordering, simply add the letters "PT" to the thief hatch series number (Example: Enardo 660LB-PT).

This sectional view of the Enardo 660LB-PT shows the aluminum vacuum disk and valve seat used on all Plastic Trim (PT) models.

Standard Pressure Settings

Pressure settings are available in 2, 4, 6, 8, 12, 16, 24 or 32 oz./sq. in. Savings in tank product may be achieved by using higher pressures on the thief hatch for tanks designed to withstand such pressures. These higher pressures are obtained by using stronger or heavier springs in the pressure

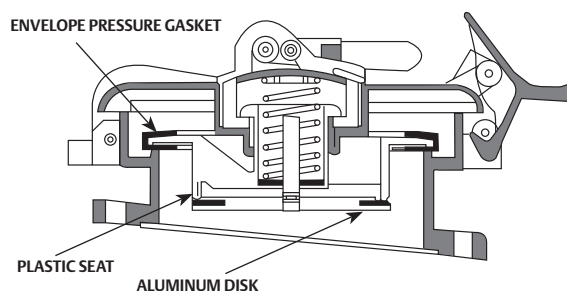

Figure 1. Sectional View of the Enardo™ 660LB-PT

valve. Pressure settings on the hatch can easily be changed by removing the existing spring and replacing it with another of the desired pressure. Pressure settings should always be in accordance with the tank manufacturers' specifications. To prevent the hatch from opening, the pressure setting on the hatch should be from 2 to 4 oz./sq. in. greater than that on the vent valve in the vapor line.

Hatch Use

Unless gauging or thieving, tank thief hatches should be kept closed to prevent loss of product.

Pressure Relief Valves and Thief Hatches are capable of relieving the pressures generated when tanks are being filled at rates of as much as 1750 barrels per hour. For added safety, stop plugs are incorporated to prevent the hatch cover from striking the tank and causing a spark while being opened. Hatches should be opened slowly and allowed to drop back against the stop plugs easily. When closing the hatch, the cover should be lowered easily and never allowed to drop down with its full weight.

Inconel® is a mark owned by Special Metals Corporation.

Enardo A, A-L and 200

Dead Weight Thief Hatch

Introduction

Enardo™ A are dead weight pressure relief gauge and thief hatches with round 8 in. nominal diameter API bases that also provide vacuum relief capacity.

Enardo A-L and Enardo 200 are dead weight pressure-vacuum relief gauge and thief hatches with (8 x 18 in.) and (8 x 22 in.) oblong API bases, respectively.

When excessive pressure builds within the storage tank, the vent's hinged cover begins to open at the predetermined set pressure, relieving excess pressure. When the overpressure has dissipated, the cover reseats onto the base. The hinge mechanism prevents misalignment and provides an accurate reseal.

When excessive vacuum builds within the storage tank, the spring-loaded pallet lifts, breaking the seal between the seat and pallet, allowing vapors to pass through the valve orifice relieving the vacuum buildup. The vacuum valve reseals upon relief and remains sealed.

Size

Enardo A

8 in. API

Enardo A-L

8 x 18 in. API

Enardo 200

8 x 22 in. API

Valve Setting Range

Pressure

Enardo A:

2, 4, 6 oz./sq. in.

Enardo A-L:

2, 3, 4, 6 oz./sq. in.

Enardo 200:

1, 2, 3, 4, 6 oz./sq. in.

Vacuum

0.4 oz./sq. in.

Construction Materials

Housing

Aluminum

Lid

Aluminum or Ductile Iron

P/V Gasket

Buna-N or Viton®

Hardware

Zinc-plated carbon steel

Vacuum Pallet

Aluminum

Vacuum Spring

Zinc-plated carbon steel

Additional Technical Data

For more technical information, contact your local Sales Office or log on to:

www.enardo.com

Features

- Full opening lid design for higher venting capacity requirements.
- Field replaceable gaskets without the need of special tools or complex procedures.
- Optional gasket materials available for "Sour Gas" or corrosive applications.
- Non-Corrosive coating option for extremely harsh environments.
- Certified flow capacities in accordance with API.

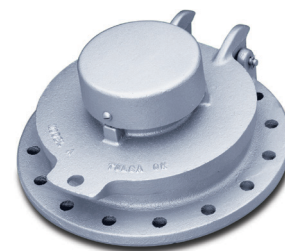

Figure 1. Enardo A



Figure 2. Enardo A-L



Figure 3. Enardo 200

Viton® is a mark owned by E. I. du Pont de Nemours and Company.

Enardo A, A-L and 200

Dead Weight Thief Hatch

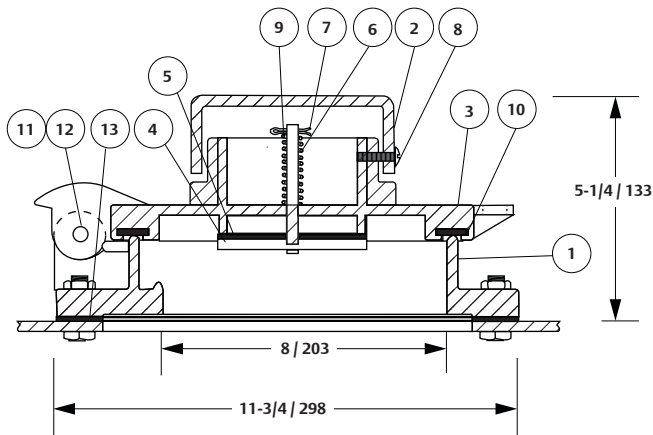

Figure 4. Enardo™ A

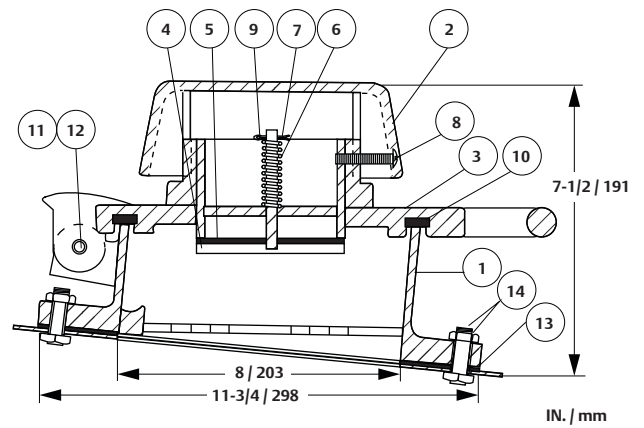

Figure 5. Enardo A-L

Table 1. Enardo A

KEY	PART NUMBER	PART NAME	MATERIAL	QUANTITY
1	11	Base	Aluminum	1
1 ⁽¹⁾	WN	Base	Steel	1
2	A101-2	Cap	Cast Iron	1
3	A102-2	Center (2 oz./sq. in.)	Cast Aluminum	1
3 ⁽¹⁾	A102	Center (4 and 6 oz./sq. in.)	Cast Iron	1
4	A103	Vacuum Disk	Cast Aluminum	1
5	A104	Vacuum Gasket	Buna-N	1
5 ⁽¹⁾	A104V	Vacuum Gasket	Viton®	1
6	A105	Vacuum Disk Spring	Stainless Steel	1
7	A106	Cotter Key	Plated	1
8	A107	Cap Set Screw	Plated	1
9	A108	Washer	Plated	2
10	110G	Pressure Gasket	Sponge Neoprene	1
10 ⁽¹⁾	110-GV	Pressure Gasket	Sponge Viton®	1
11	5-K	Hinge Pin	CRS Plated	1
12	HPC-148	Hinge Pin Clip	Plated	2
13 ⁽¹⁾	110-BG	Base Gasket	Tank Packing	1
14 ⁽¹⁾	1/2-13x1 1/2	Bolt, Hex	Plated	16
14 ⁽¹⁾	1/2-13	Nut, Hex	Plated	16

1. Optional - Furnished upon request only.

Table 2. Enardo A-L

KEY	PART NUMBER	PART NAME	MATERIAL	QUANTITY
1	1A	Base	Aluminum	1
2	A111	Cap	Cast Iron	1
3	A112	Center (2 oz./sq. in.)	Cast Iron	1
3 ⁽¹⁾	A114	Center (4 oz./sq. in.)	Cast Iron	1
4	A103	Vacuum Disk	Cast Aluminum	1
5	A104	Vacuum Gasket	Buna-N	1
5 ⁽¹⁾	A104V	Vacuum Gasket	Viton®	1
6	A105	Vacuum Disk Spring	Stainless Steel	1
7	A106	Cotter Key	Plated	1
8	A107	Cap Set Screw	Plated	1
9	A108	Washer	Plated	2
10	10G	Pressure Gasket	Sponge Neoprene	1
10 ⁽¹⁾	10GV	Pressure Gasket	Sponge Viton®	1
11	5	Hinge Pin	CRS Plated	1
12	HPC-148	Hinge Pin Clip	Plated	2
13 ⁽¹⁾	AL-BG	Base Gasket	Tank Packing	1
14 ⁽¹⁾	1/2-13-1-1/2	Bolt, Hex	Plated	26
14 ⁽¹⁾	1/2-13	Nut, Hex	Plated	26

1. Optional - furnished upon request only.

Viton® is a mark owned by E. I. du Pont de Nemours and Company.

Enardo A, A-L and 200

Dead Weight Thief Hatch

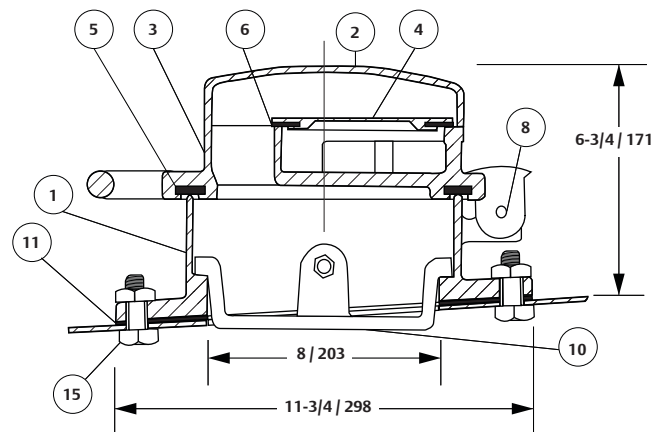

IN. / mm

Figure 6. Enardo™ 200

Table 3. Enardo 200

KEY	PART NUMBER	PART NAME	MATERIAL	QUANTITY
1	21	Base	Aluminum	1
2	3	Cap	Cast Aluminum	1
3	22	Center (2 oz./sq. in.)	Cast Iron	1
3 ⁽²⁾	22A	Center (1 oz./sq. in.)	Cast Aluminum	1
3 ⁽²⁾	22-W-4	Center weight (4 oz./sq. in.)	Cast Iron	2
4	4	Vacuum Disk	Cast Aluminum	1
4 ⁽¹⁾	4P	Vacuum Disk	Phenolic	1
5	200G	Pressure Gasket	Sponge Neoprene	1
6	4G	Vacuum Gasket	Buna-N	1
8	5	Hinge Pin	CRS Plated	1
11 ⁽²⁾	200 BG	Base Gasket	Tank Packing	1
12	10-24	Machine Screw, R.H.	Plated	4
14	HCP-148	Hinge Pin Clip	Plated	2
15 ⁽²⁾	1/2-13	Bolt, Hex	Plated	30
15 ⁽²⁾	1/2-13	Nut, Hex	Plated	3

1. Plastic Trim Series.

2. Furnished upon request only GTHV-16.

Enardo 1000

Lock Down Hatch

Introduction

Enardo™ 1000 lock down hatches provide access for storage tanks. When closed, it assures a vapor tight seal that prevents leakage and evaporation loss. It is designed for easy installation, inspection and maintenance providing trouble free operation. Its non-sparking design provides easy access for gauging, sampling, temperature measurement or inspection.

Valve Setting Range

Bolt Pattern 1

8 in. ANSI 150 lb.

Bolt Pattern 2

8 in. API

Construction Materials

Construction

Base, Arm and Lid: Aluminum

Gasket: Closed Cell Sponge Neoprene (CR)

Optional Equipment

Special Application Gasketing, Bolt and Gasket Set, Base Gasket only and Non-corrosive Coating Foot Pedal Operator

Approximate Shipping Weight

20 lbs

Additional Technical Data

For more technical information, contact your local Sales Office or log on to:

www.enardo.com

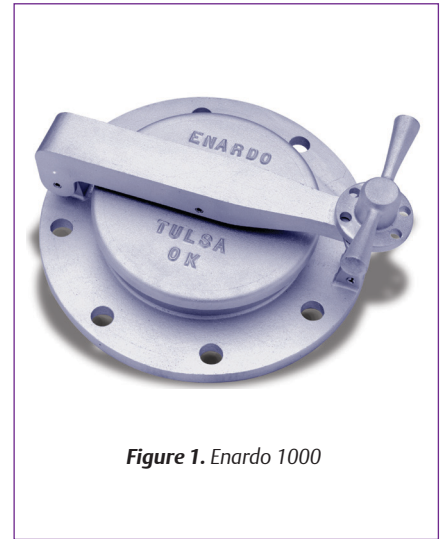

Figure 1. Enardo 1000

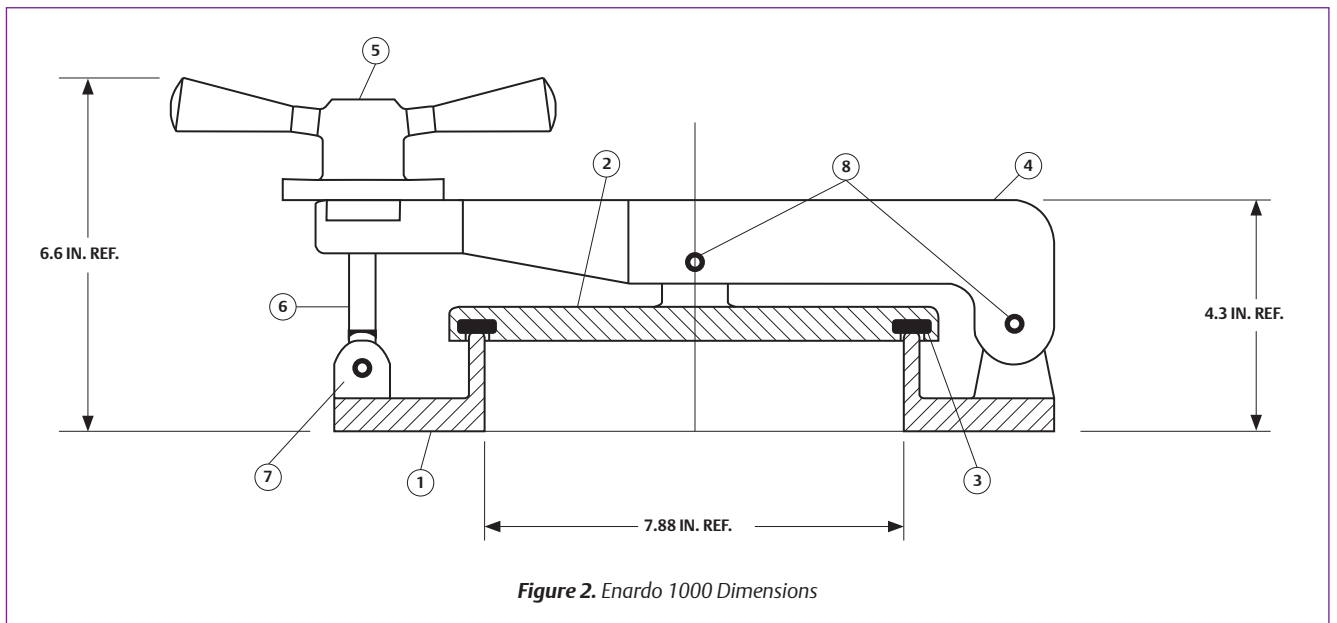

Figure 2. Enardo 1000 Dimensions

Table 1. Enardo 1000 Parts List

KEY	PART NUMBER	PART NAME	MATERIAL	QUANTITY
1	1008-01	Base	Cast Aluminum	1
2	1008-02	Lid	Cast Aluminum	1
3	1008-03	Lid Gasket	Nitrile (NBR)	1
4	1008-04	Arm	Cast Aluminum	1
5	1008-05	Handle	Cast Aluminum	1
6	1008-06	Swing Bolt	Cast Aluminum	1
7	1007-07	Roll Pin 1 x 1.38	Plated Steel	1
8	1008-08	Roll Pin 2 x 2	Plated Steel	2

Enardo 660 and Enardo 660-L

Thief Hatch

Introduction

Enardo™ 660 spring-loaded thief hatches are designed with a round base and cover. It is intended for use on steel and fiberglass tanks which require a tighter seal for reduced vapor loss.

Enardo 660-L is a spring-loaded thief hatch designed with a long basin and cover. The long basin serves as a thief shelf. The design also includes an inclining base to keep the basin level.

Model Numbers

Enardo 660 and Enardo 660-L

Bolt Pattern

8 in. API

Valve Setting Range

Pressure: 2, 4, 6, 8, 12, 16, 24 and 32 oz./sq. in.

Vacuum: 0.4, 0.9 and 3.5 oz./sq. in.

Construction Materials

Construction

Aluminum castings (non-sparking)

Optional Equipment

Plastic Trim (PT), Base Gasket, Bolt Set, Non-Corrosive Coating

Approximate Shipping Weight

Enardo 660: 25 lbs

Enardo 660-L: 45 lbs

Additional Technical Data

For more technical information, contact your local Sales Office or log on to:

www.enardo.com



Figure 1. Enardo 660

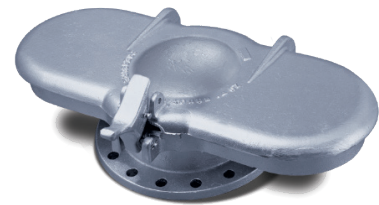

Figure 2. Enardo 660-L

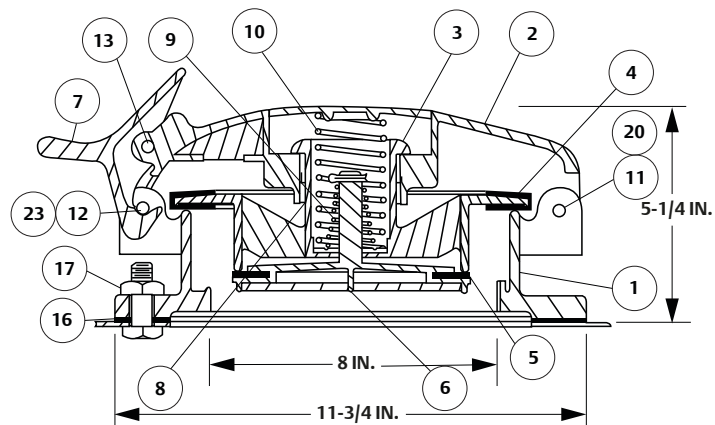

Figure 3. Enardo 660 Assembly Drawing

Table 1. Enardo 660

KEY	PART NUMBER	PART NAME	MATERIAL	QUANTITY
1	61A	Base	Cast Aluminum	1
2	63	Cover	Cast Aluminum	1
3	72SA	Center (see Center Assembly)	Assembly	1
3 ⁽¹⁾	72SA1-PT	Center (see Center Assembly)	Plastic Assembly	1
4	70-H	Envelope Pressure Gasket	Nitrile (NBR)	1
4 ⁽¹⁾	70-HV	Envelope Pressure Gasket	Viton®	1
5	74-G	Vacuum Gasket	Buna-N	1
5 ⁽¹⁾	74-GV-SP	Vacuum Gasket	Viton® Sponge	1
6	64-F	Vacuum Disk	Cast Aluminum	1
7	9	Latch	Cast Aluminum	1
8	72	Center	Cast Aluminum	1
9	660-VS-1/2	Vacuum Spring	Plated	1
9 ⁽¹⁾	660-VS-1/2I	Vacuum Spring	Inconel®	1
10	660-PS-4	Pressure Spring	Plated	1
10 ⁽¹⁾	660-PS-4I	Pressure Spring	Inconel®	1
11	4505112	Hinge Clevis Pin	CRS Plated	1
12	4505110	Latching Clevis Pin	CRS Plated	1
13	5-C	Latch Pin	CRS Plated	1
16 ⁽²⁾	660-BG	Base Gasket	Tank Packing	1
17 ⁽²⁾	1/2 - 13 x 1 - 1/2	Hex Bolt	Plated	16
17 ⁽²⁾	1/2-13	Hex Nut	Plated	16
19	HCP-148	Hinge Pin Clip	Plated	6
20	2000703	Hinge/Latching Cotter Pin	Plated	2

1. Plastic trim series furnished upon request only - for sour gas.

2. Furnished upon request only.

Enardo 660 and Enardo 660-L

Thief Hatch

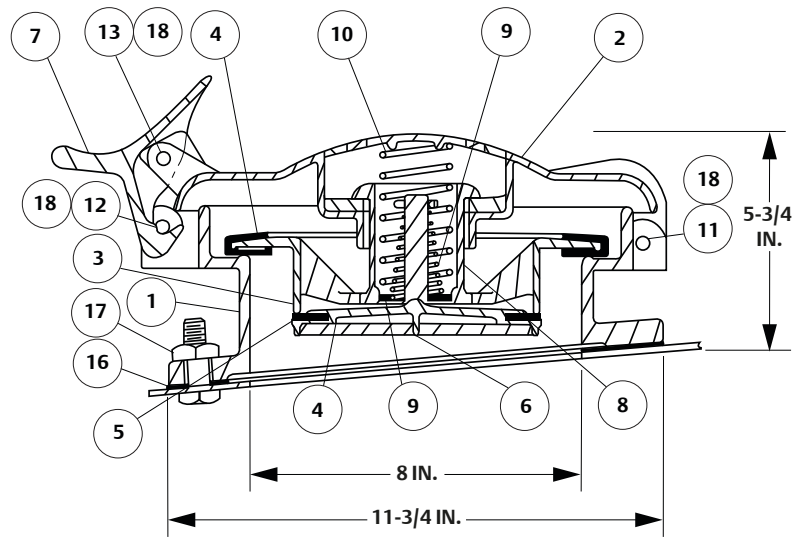

Figure 4. Enardo™ 660-L Assembly Drawing

Table 2. Enardo 660-L

KEY	PART NUMBER	PART NAME	MATERIAL	QUANTITY
1	61LC	Base	Cast Aluminum	1
2	63L	Cover	Cast Aluminum	1
3	72SA1	Center (see Center Assembly)	Assembly	1
3 ⁽¹⁾	72SA1-PT	Center (see Center Assembly)	Plastic Assembly	1
4	70-H	Envelope Pressure Gasket	Nitrile (NBR)	1
4 ⁽¹⁾	70-HV	Envelope Pressure Gasket	Viton®	1
5	74-G	Vacuum Gasket	Buna-N	1
5 ⁽¹⁾	74-GV-SP	Vacuum Gasket	Viton® Sponge	1
6	64-F	Vacuum Disk	Cast Aluminum	1
7	9	Latch	Cast Aluminum	1
8	72	Center	Cast Aluminum	1
9	660-VS-1/2	Vacuum Spring	Plated	1
9 ⁽¹⁾	660-VS-1/2I	Vacuum Spring	Inconel®	1
10	660-PS-4	Pressure Spring	Plated	1
10 ⁽¹⁾	660-PS-4I	Pressure Spring	Inconel®	1
11	5	Cover Hinge Pin	CRS Plated	1
12	5-N	Latching Pin	CRS Plated	1
13	5-C	Latch Pin	CRS Plated	1
16 ⁽²⁾	660-BG	Base Gasket	Tank Packing	1
17 ⁽²⁾	1/2 - 13 x 1 - 1/2	Hex Bolt	Plated	16
17 ⁽²⁾	1/2-13	Hex Nut	Plated	16
18	HCP-148	Hinge Pin Clip	Plated	6

1. Plastic trim series furnished upon request only - for sour gas.
2. Furnished upon request only.

Inconel® is a mark owned by Special Metals Corporation.
Viton® is a mark owned by E. I. du Pont de Nemours and Company.

Enardo 660-B and Enardo 660-LB

Thief Hatch

Introduction

Enardo™ 660-B spring-loaded thief hatches are designed with a round base and cover. This hatch is provided with a bleeder attachment making it possible to relieve tank pressure before opening the hatch. This bleeder prevents a spray from discharging when the hatch cover is raised. This hatch is designed for storage applications that require a tighter seal for reduced vapor loss.

Enardo 660-LB spring-loaded thief hatch has a long basin and cover with an inclining base.

Model Numbers

Enardo 660-B and Enardo 660-LB

Bolt Pattern

8 in. API

Valve Setting Range

Pressure: 2, 4, 6, 8, 12, 16, 24 and 32 oz./sq. in.

Vacuum: 0.4, 0.9 and 3.5 oz./sq. in.

Construction Materials

Construction: Aluminum castings (non-sparking)

Optional Equipment: Plastic Trim (PT), Base Gasket, Bolt Set, Non-Corrosive Coating

Approximate Shipping Weight

Enardo 660-B: 28 lbs

Enardo 660-LB: 45 lbs

Additional Technical Data

For more technical information, contact your local Sales Office or log on to:

www.enardo.com

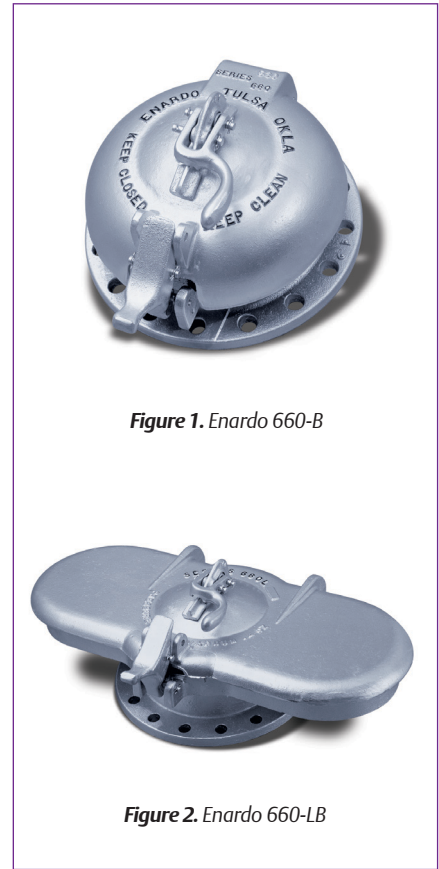

Figure 1. Enardo 660-B

Figure 2. Enardo 660-LB

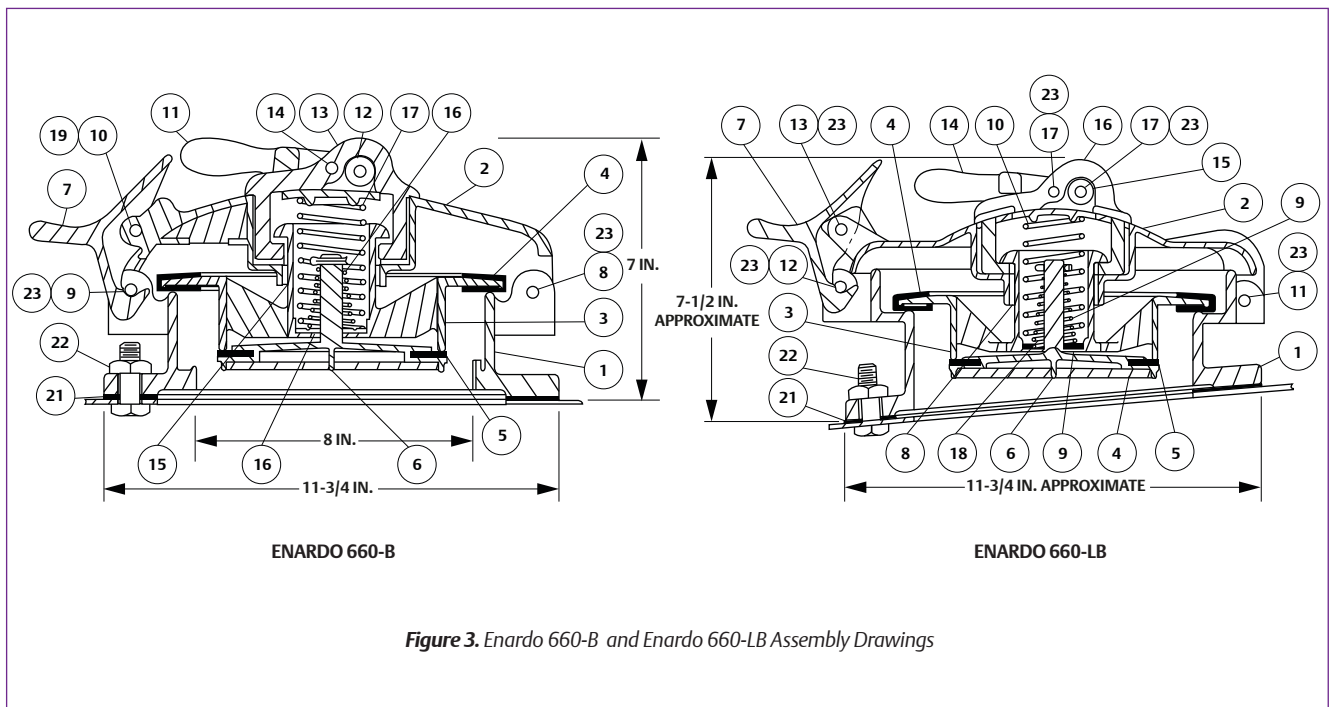

Figure 3. Enardo 660-B and Enardo 660-LB Assembly Drawings

Enardo 660-B and Enardo 660-LB

Thief Hatch

Table 1. Enardo™ 660-B

KEY	PART NUMBER	PART NAME	MATERIAL	QUANTITY
1	61A	Base	Cast Aluminum	1
2	63B	Center with bleeder	Cast Aluminum	1
3	72SA1	Center (see Center Assembly)	Assembly	1
3 ⁽¹⁾	72SA1-PT	Center (see Center Assembly)	Plastic Assembly	1
4	70-H	Envelope Pressure Gasket	Nitrile (NBR)	1
4 ⁽¹⁾	70-HV	Envelope Pressure Gasket	Viton®	1
5	74-G	Vacuum Gasket	Buna-N	1
5 ⁽¹⁾	74-GV-SP	Vacuum Gasket	Viton® Sponge	1
6	64-F	Vacuum Disc	Cast Aluminum	1
7	9	Latch	Cast Aluminum	1
8	4505112	Hinge Clevis Pin	CRS Plated	1
9	4505110	Latching Clevis Pin	CRS Plated	1
10	5-C	Latch Pin	CRS Plated	1
11	14-H	Bleeder Handle	Cast Aluminum	1
12	14-HR	Bleeder Roller	CRS Plated	1
13	14-C	Bleeder	Cast Aluminum	1
14	5-C	Bleeder Hinge Pin	CRS Plated	2
15	72	Center	Cast Aluminum	1
16	660-VS-1/2	Vacuum Spring	Plated	1
16 ⁽¹⁾	660-VS-1/2I	Vacuum Spring	Inconel®	1
17	660-PS-4	Pressure Spring	Plated	1
17 ⁽¹⁾	660-PS-4I	Pressure Spring	Inconel®	1
19	HCP-148	Hinge Pin Clip	Plated	6
21 ⁽²⁾	660-BG	Base Gasket	Tank Packing	1
22 ⁽²⁾	1/2 - 13 x 1 - 1/2	Bolt, Hex	Plated	16
22 ⁽²⁾	1/2-13	Nut, Hex	Plated	16
23	2000703	Hinge/Latching Cotter Pin	Plated	2

1. Plastic trim series furnished upon request only - for sour gas.
2. Furnished upon request only.

Table 2. Enardo 660-LB

KEY	PART NUMBER	PART NAME	MATERIAL	QUANTITY
1	61LC	Base	Cast Aluminum	1
2	63LB	Center with bleeder	Cast Aluminum	1
3	72SA1	Center (see Center Assembly)	Assembly	1
3 ⁽¹⁾	72SA1-PT	Center (see Center Assembly)	Plastic Assembly	1
4	70-H	Envelope Pressure Gasket	Nitrile (NBR)	1
4 ⁽¹⁾	70-HV	Envelope Pressure Gasket	Viton®	1
5	74-G	Vacuum Gasket	Buna-N	1
5 ⁽¹⁾	74-GV-SP	Vacuum Gasket	Viton® Sponge	1
6	64-F	Vacuum Disc	Cast Aluminum	1
7	9	Latch	Cast Aluminum	1
8	72	Center	Cast Aluminum	1
9	660-VS-1/2	Vacuum Spring	Plated	1
9 ⁽¹⁾	660-VS-1/2I	Vacuum Spring	Inconel®	1
10	660-PS-4	Pressure Spring	Plated	1
10 ⁽¹⁾	660-PS-4I	Pressure Spring	Inconel®	1
11	5	Cover Hinge Pin	CRS Plated	1
12	5-N	Latching Pin	CRS Plated	2
13	5-C	Latch Pin	CRS Plated	1
14	14-H	Bleeder Handle	Cast Aluminum	1
15	14-HR	Bleeder Roller	CRS Plated	1
16	14-C	Bleeder	Cast Aluminum	1
17	5-C	Bleeder Hinge Pin	CRS Plated	2
21 ⁽²⁾	660-BG	Base Gasket	Tank Packing	1
22 ⁽²⁾	1/2 - 13 x 1 - 1/2	Bolt, Hex	Plated	16
22 ⁽²⁾	1/2-13	Nut, Hex	Plated	16
23	HCP-148	Hinge Pin Clip	Plated	10

1. Plastic trim series furnished upon request only - for sour gas.
2. Furnished upon request only.

Inconel® is a mark owned by Special Metals Corporation.
Viton® is a mark owned by E. I. du Pont de Nemours and Company.



Enardo ES-660 and Enardo ES-660-L

Thief Hatch

Introduction

Enardo™ ES-660 Series high-performance thief hatches are step forward in sealing technology. Unlike standard tank hatches, the Enardo ES-660 Series is proven to deliver a higher level of protection in the industry against thief hatch product leakage and fugitive emissions. Engineered with precision-manufactured internal components and multiple seal selections, the Enardo ES-660 Series provides tighter sealing for applications that require greater emissions control.

Enardo ES-660 Series are available as a complete replacement for any standard API 8 in. thief hatch or as a simple retrofit for any Enardo 660 Series hatch.

Enardo ES-660 spring-loaded thief hatch is designed with a round base and cover. It is intended for use on steel and fiberglass tanks which require a tighter seal for reduced vapor loss.

Enardo ES-660-L is a spring-loaded thief hatch designed with a long basin and cover. The long basin serves as a thief shelf. The design also includes an inclining base to keep the basin level.

Model Numbers

Enardo ES-660 and Enardo ES-660-L

Performance

Tight to 1 SCFH at 90% of setpoint

Bolt Pattern

8 in. API

Valve Setting Range

Pressure: 4, 6, 8, 12, 16, 24 and 32 oz./sq. in.

Vacuum: 0.4, 0.9 and 3.5 oz./sq. in.

Construction Materials

Construction: Aluminum (non-sparking)

Pressure Gasket: HNBR (standard) and Viton®

Vacuum Gasket: Fluorosilicone (standard), Viton® and Teflon®

Optional Equipment: Base Gasket, Bolt Set, Non-Corrosive Coating

Approximate Shipping Weight

Enardo ES-660: 25 lbs

Enardo ES-660-L: 45 lbs

Additional Technical Data

For more technical information, contact your local Sales Office or log on to:

www.enardo.com



Figure 1. Enardo ES-660

Figure 2. Enardo ES-660-L

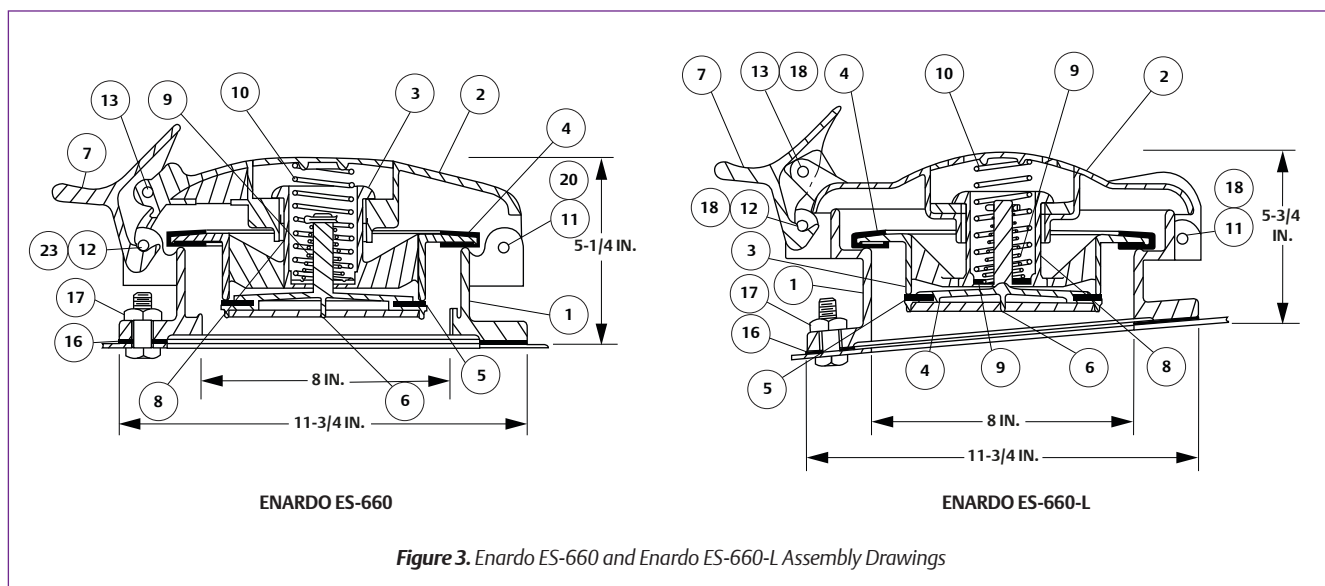

Figure 3. Enardo ES-660 and Enardo ES-660-L Assembly Drawings

Teflon® and Viton® are marks owned by E. I. du Pont de Nemours and Company.

Enardo ES-660 and Enardo ES-660-L

Thief Hatch

Table 1. Enardo™ ES-660

KEY	PART NUMBER	PART NAME	MATERIAL	QUANTITY
1	61A	Base	Cast Aluminum	1
2	63	Cover	Cast Aluminum	1
3	4539300	Center Assembly	Aluminum/HNBR	1
4	70-H	Envelope Pressure Gasket	Nitrile (NBR)	1
4 ⁽¹⁾	70-HV	Envelope Pressure Gasket	Viton®	1
5	4504705	Vacuum Gasket	Fluorosilicone	1
5 ⁽¹⁾	4504707	Vacuum Gasket	Viton® Sponge	1
6	4539105	Vacuum Disk	Aluminum	1
7	9	Latch	Cast Aluminum	1
8	4501051	Center	Cast Aluminum	1
9	660-VS-1/2	Vacuum Spring	Plated	1
9 ⁽¹⁾	660-VS-1/2I	Vacuum Spring	Inconel®	1
10	660-PS-4	Pressure Spring	Plated	1
10 ⁽¹⁾	660-PS-4I	Pressure Spring	Inconel®	1
11	4505112	Hinge Clevis Pin	CRS Plated	1
12	4505110	Latching Clevis Pin	CRS Plated	1
13	5-C	Latch Pin	CRS Plated	1
16 ⁽²⁾	660-BG	Base Gasket	Tank Packing	1
17 ⁽²⁾	1/2 - 13 x 1 - 1/2	Bolt, Hex	Plated	16
17 ⁽²⁾	1/2 - 13	Nut, Hex	Plated	16
19	HCP-148	Hinge Pin Clip	Plated	6
20	2000703	Hinge/Latching Cotter Pin	Plated	2

1. Plastic trim series furnished upon request only - for sour gas.
2. Furnished upon request only.

Table 2. Enardo ES-660-L

KEY	PART NUMBER	PART NAME	MATERIAL	QUANTITY
1	61LC	Base	Cast Aluminum	1
2	63L	Cover	Cast Aluminum	1
3	4539300	Center Assembly	Aluminum/HNBR	1
4	70-H	Envelope Pressure Gasket	Nitrile (NBR)	1
4 ⁽¹⁾	70-HV	Envelope Pressure Gasket	Viton®	1
5	4504705	Vacuum Gasket	Fluorosilicone	1
5 ⁽¹⁾	4504707	Vacuum Gasket	Viton® Sponge	1
6	4539105	Vacuum Disk	Aluminum	1
7	9	Latch	Cast Aluminum	1
8	4501051	Center	Cast Aluminum	1
9	660-VS-1/2	Vacuum Spring	Plated	1
9 ⁽¹⁾	660-VS-1/2I	Vacuum Spring	Inconel®	1
10	660-PS-4	Pressure Spring	Plated	1
10 ⁽¹⁾	660-PS-4I	Pressure Spring	Inconel®	1
11	5	Cover Hinge Pin	CRS Plated	1
12	5-N	Latching Pin	CRS Plated	1
13	5-C	Latch Pin	CRS Plated	1
16 ⁽²⁾	660-BG	Base Gasket	Tank Packing	1
17 ⁽²⁾	1/2 - 13 x 1 - 1/2	Bolt, Hex	Plated	16
17 ⁽²⁾	1/2 - 13	Nut, Hex	Plated	16
18	HCP-148	Hinge Pin Clip	Plated	6

1. Plastic trim series furnished upon request only - for sour gas.
2. Furnished upon request only.

Inconel® is a mark owned by Special Metals Corporation.
Viton® is a mark owned by E. I. du Pont de Nemours and Company.



Enardo ES-660-B and Enardo ES-660-LB

Thief Hatch

Introduction

Enardo™ ES-660 Series high-performance thief hatches are step forward in sealing technology. Unlike standard tank hatches, the Enardo ES-660 Series is proven to deliver a higher level of protection in the industry against thief hatch product leakage and fugitive emissions. Engineered with precision-manufactured internal components and multiple seal selections, the Enardo ES-660 Series provides tighter sealing for applications that require greater emissions control.

Enardo ES-660 Series are available as a complete replacement for any standard API 8 in. thief hatch, or as a simple retrofit for any Enardo 660 Series hatch.

The Enardo ES-660-B spring-loaded thief hatch is designed with a round base and cover. This hatch is provided with a bleeder attachment making it possible to relieve tank pressure before opening the hatch. This bleeder prevents a spray from discharging when the hatch cover is raised.

Enardo ES-660-LB spring-loaded thief hatch has a long basin and cover with an inclining base.

Model Numbers

Enardo ES-660-B and
Enardo ES-660-LB

Performance

Tight to 1 SCFH at 90% of setpoint

Bolt Pattern

8 in. API

Valve Setting Range

Pressure
4, 6, 8, 12, 16, 24 and 32 oz./sq. in.

Vacuum
0.4, 0.9 and 3.5 oz./sq. in.

Construction Materials

Construction

Aluminum (non-sparking)

Pressure Gasket

HNBR (**standard**) and Viton®

Vacuum Gasket

Fluorosilicone (**standard**),
Viton® and Teflon®

Optional Equipment

Base Gasket, Bolt Set,
Non-Corrosive Coating

Approximate Shipping Weight

Enardo ES-660-B: 28 lbs

Enardo ES-660-LB: 45 lbs

Additional Technical Data

For more technical information, contact
your local Sales Office or log on to:

www.enardo.com



Figure 1. Enardo ES-660-B

Figure 2. Enardo ES-660-LB

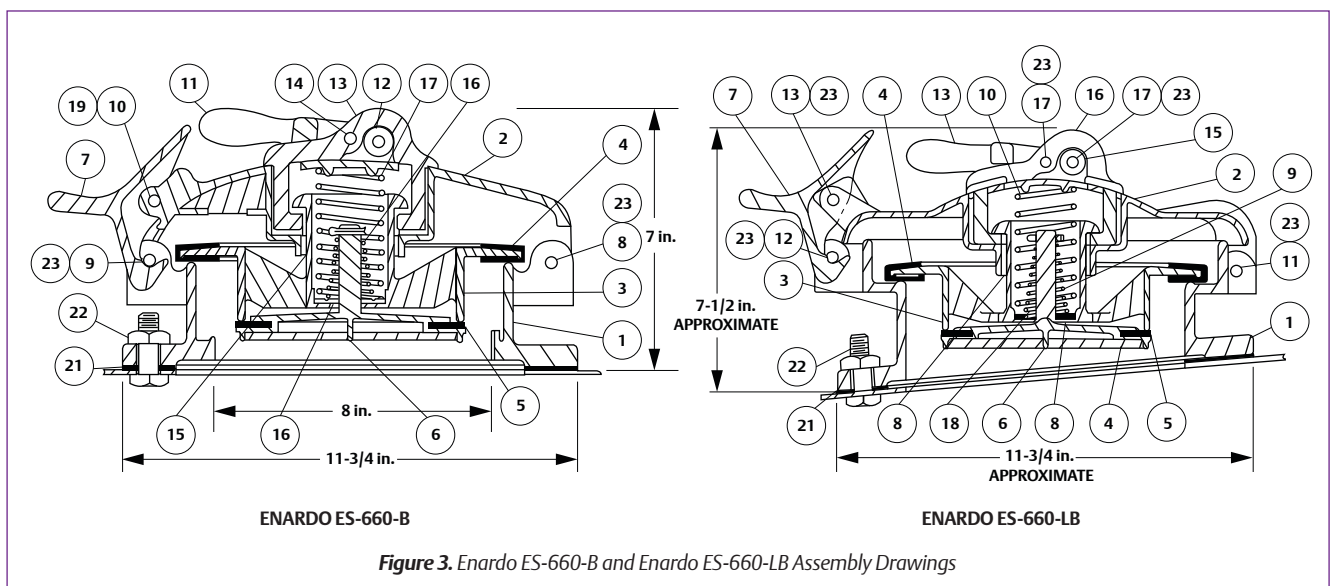

Figure 3. Enardo ES-660-B and Enardo ES-660-LB Assembly Drawings

Teflon® and Viton® are marks owned by E. I. du Pont de Nemours and Company.



Enardo ES-660-B and Enardo ES-660-LB

Thief Hatch

Table 1. Enardo™ ES-660-B

KEY	PART NUMBER	PART NAME	MATERIAL	QUANTITY
1	61A	Base	Cast Aluminum	1
2	63B	Cover with Bleeder	Cast Aluminum	1
3	4539300	Center Assembly	Aluminum/HNBR	1
4	70-H	Envelope Pressure Gasket	Nitrile (NBR)	1
4 ⁽¹⁾	70-HV	Envelope Pressure Gasket	Viton®	1
5	4504705	Vacuum Gasket	Fluorosilicone	1
5 ⁽¹⁾	4504707	Vacuum Gasket	Viton® Sponge	1
6	4539105	Vacuum Disk	Aluminum	1
7	9	Latch	Cast Aluminum	1
8	4505112	Hinge Clevis Pin	CRS Plated	1
9	4505110	Latching Clevis Pin	CRS Plated	1
10	5-C	Latch Pin	CRS Plated	1
11	14-H	Bleeder Handle	Cast Aluminum	1
12	14-HR	Bleeder Roller	CRS Plated	1
13	14-C	Bleeder	Cast Aluminum	1
14	5-C	Bleeder Hinge Pin	CRS Plated	2
15	4501051	Center	Cast Aluminum	1
16	660-VS-1/2	Vacuum Spring	Plated	1
16 ⁽¹⁾	660-VS-1/2I	Vacuum Spring	Inconel®	1
17	660-PS-4	Pressure Spring	Plated	1
17 ⁽¹⁾	660-PS-4I	Pressure Spring	Inconel®	1
19	HCP-148	Hinge Pin Clip	Plated	2
21 ⁽²⁾	660-BG	Base Gasket	Tank Packing	1
22 ⁽²⁾	1/2-13 x 1-1/2	Bolt, Hex	Plated	16
22 ⁽²⁾	1/2-13	Nut, Hex	Plated	16
23	2000703	Hinge/Latching Cotter Pin	Plated	2

1. Plastic trim series furnished upon request only - for sour gas.
2. Furnished upon request only.

Table 2. Enardo ES-660-LB

KEY	PART NUMBER	PART NAME	MATERIAL	QUANTITY
1	61LC	Base	Cast Aluminum	1
2	63LB	Cover with Bleeder	Cast Aluminum	1
3	4539300	Center Assembly	Aluminum/HNBR	1
4	70-H	Envelope Pressure Gasket	Nitrile (NBR)	1
4 ⁽¹⁾	70-HV	Envelope Pressure Gasket	Viton®	1
5	4504705	Vacuum Gasket	Fluorosilicone	1
5 ⁽¹⁾	4504707	Vacuum Gasket	Viton® Sponge	1
6	4539105	Vacuum Disk	Aluminum	1
7	9	Latch	Cast Aluminum	1
8	4501051	Center	Cast Aluminum	1
9	660-VS-1/2	Vacuum Spring	Plated	1
9 ⁽¹⁾	660-VS-1/2I	Vacuum Spring	Inconel®	1
10	660-PS-4	Pressure Spring	Plated	1
10 ⁽¹⁾	660-PS-4I	Pressure Spring	Inconel®	1
11	5	Cover Hinge Pin	CRS Plated	1
12	5-N	Latching Pin	CRS Plated	1
13	5-C	Latch Pin	CRS Plated	1
14	14-H	Bleeder Handle	Cast Aluminum	1
15	14-HR	Bleeder Roller	CRS Plated	1
16	14-C	Bleeder	Cast Aluminum	1
17	5-C	Bleeder Hinge Pin	CRS Plated	2
21 ⁽²⁾	660-BG	Base Gasket	Tank Packing	1
22 ⁽²⁾	1/2-13 x 1-1/2	Bolt, Hex	Plated	16
22 ⁽²⁾	1/2-13	Nut, Hex	Plated	16
23	HCP-148	Hinge Pin Clip	Plated	10

1. Plastic trim series furnished upon request only - for sour gas.
2. Furnished upon request only.

Viton® is a mark owned by E. I. du Pont de Nemours and Company.
Inconel® is a mark owned by Special Metals Corporation.



Enardo ES-660-HF

Thief Hatch

Introduction

Enardo™ ES-660-HF high-performance thief hatches is a step forward in thief hatch performance, engineered to provide higher flow capacity and designed with sealing technology to provide a higher level of protection against thief hatch product leakage and fugitive emissions.

In the event of an upset condition that produces excessive pressure and flow, the Enardo ES-660-HF provides extra venting capacity to quickly relieve pressure build-up in atmospheric and low-pressure storage tanks. Unlike other high-capacity thief hatches, the Enardo ES-660-HF offers tighter sealing for applications that require greater emissions control.

Enardo ES-660-HF is spring-loaded with a round base and cover, and can replace any standard API 8 in. thief hatch. It is intended for use on steel and fiberglass tanks which require a tighter seal for reduced vapor loss and a higher volume of venting than offered by standard thief hatches.

Performance

Tight to 1 SCFH at 90% of setpoint

Bolt Pattern

8 in. API

Valve Setting Range

Pressure: 4, 6, 8, 12 and 16 oz./sq. in.

Vacuum: 0.4, 0.9 and 3.5 oz./sq. in.

Construction Materials

Construction: Aluminum (non-sparking)

Pressure Gasket: HNBR (standard) and Viton®

Vacuum Gasket: Fluorosilicone (standard), Viton® and Teflon®

Optional Equipment: Base Gasket, Bolt Set, Non-Corrosive Coating

Approximate Shipping Weight:

29 lbs.

Additional Technical Data

For more technical information, contact your local Sales Office or log on to:

www.enardo.com

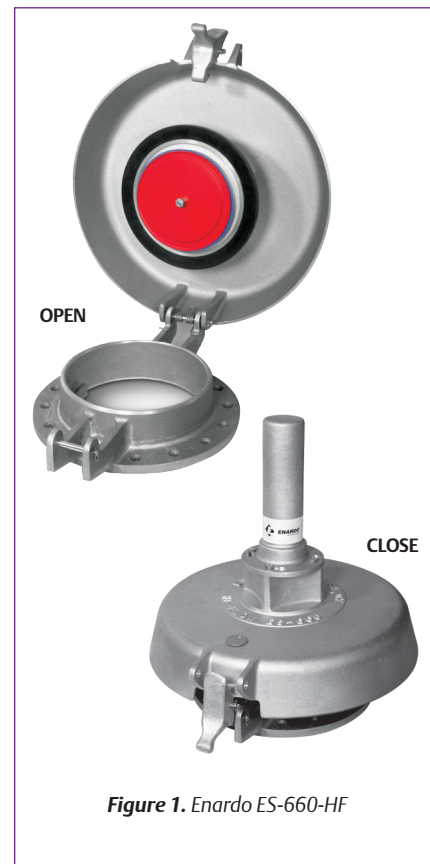

Figure 1. Enardo ES-660-HF

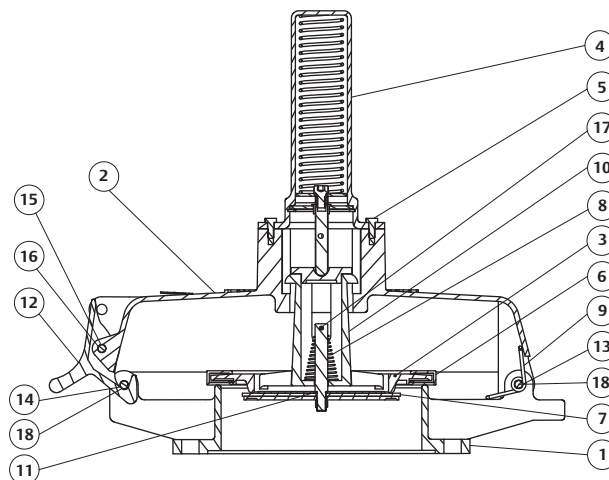

Figure 2. Enardo ES-660-HF Assembly Drawing

Teflon® and Viton® are marks owned by E. I. du Pont de Nemours and Company.

Enardo ES-660-HF

Thief Hatch

Table 1. Enardo™ ES-660-HF

KEY	MODEL	PART NUMBER	PART NAME	MATERIAL
1	----	4507303	Base	Cast aluminum
2	----	4522001	Lid	Cast aluminum
3	----	4539400	Center Assembly 0.4 oz./sq. in. Vacuum ⁽¹⁾	HNBR/ Fluorosilicone
3	----	4539401	Center Assembly 0.4 oz./sq. in. Vacuum ⁽¹⁾	HNBR/Teflon®
3	----	4539407	Center Assembly 0.4 oz./sq. in. Vacuum ⁽¹⁾	Viton®/ Sponge Viton®
3	----	4539406	Center Assembly 0.4 oz./sq. in. Vacuum ⁽¹⁾	Viton®/Viton®
3	----	4539409	Center Assembly 0.4 oz./sq. in. Vacuum ⁽¹⁾	Viton®/Fabric Viton®
4	----	4556200	Spring Capsule Assembly 4 oz./sq. in.	----
4	----	4556201	Spring Capsule Assembly 6 oz./sq. in.	----
4	----	4556202	Spring Capsule Assembly 8 oz./sq. in.	----
4	----	4556203	Spring Capsule Assembly 12 oz./sq. in.	----
4	----	4556204	Spring Capsule Assembly 16 oz./sq. in.	----
5	----	2035901	Spring Capsule Bolt, 4 Required	----
6	70-H	4504601	Pressure Gasket	ENV #70-HH HBNR
6	----	4504603	Pressure Gasket	ENV #70-HH Blue Viton®
7	VAC ES-660	4504705	Vacuum Gasket	Fluorosilicone
7	----	4504706	Vacuum Gasket	Teflon®
7	----	4504707	Vacuum Gasket	Sponge Viton®
7	----	4504708	Vacuum Gasket	Blue Viton®
7	----	4504709	Vacuum Gasket	Black Fabric Viton®
8	660-VS-1/2	4503700	Vacuum Spring 0.4 oz./sq. in.	Galvanized steel
8	660-VS-1/2I	4503800	Vacuum Spring 0.4 oz./sq. in.	Inconel®
9	----	4504005	Hinge Spring	----
10	----	4506000	Center	----
11	----	2012710	Vacuum Pallet O-ring	----
12	----	4524100	Latch	----
13	5-O	4505112	Clevis Pin 5/16 x 3-1/2	----
14	5-F	4505110	Clevis Pin 5/16 x 2-1/2	----
15	5-C	4505103	Latch Pin	----
16	HPC-148	2027100	Hinge Pin Clip	----
17	347	2022101	Cotter Pin 1/8 x 1	304 Stainless steel
18	----	2000703	Cotter Pin 1/8 x 1/2	----

1. Center assemblies are not supplied with pressure springs.

Inconel® is a mark owned by Special Metals Corporation.
Viton® and Teflon® are marks owned by E. I. du Pont de Nemours and Company.

Enardo ES-665

Thief Hatch

Introduction

Enardo™ ES-665 Series high-performance thief hatches are a quantum step forward in sealing technology. Unlike standard tank hatches, the Enardo ES-665 Series is proven to deliver the highest level of protection in the industry against thief hatch product leakage and fugitive emissions. Engineered with precision-manufactured internal components and multiple seal selections, only the Enardo ES-665 Series provide ultra-tight sealing for applications that require maximum emissions control.

Enardo ES-665 Series are available as a complete replacement for any standard API 8 in. thief hatch or as a simple retrofit for any Enardo 660 or ES-660 Series hatch.

The Enardo ES-665 spring-loaded thief hatch is designed with a round base and cover. It is intended for use on steel and fiberglass tanks which require a tighter seal for reduced vapor loss.

Model Numbers

Enardo ES-665

Performance

0.10 SCFH at 90% of set pressure, at ambient conditions

Bolt Pattern

8 in. API

Valve Setting Range

Pressure: 4, 6, 8, 12, 16, 24 and 32 oz./sq. in.

Vacuum: 0.4, 0.9 and 3.5 oz./sq. in.

Construction Materials

Construction: Aluminum (non-sparking)

Pressure Gasket: HNBR (standard), Viton®, Fluorosilicone and Ethylene Propylene Diene Monomer (EPDM)

Vacuum Gasket: Viton®, Fluorosilicone (standard) and EPDM

Optional Equipment: Base Gasket, Bolt Set, Non-Corrosive Coating, Bonding Strap

Approximate Shipping Weight

25 lbs

Additional Technical Data

For more technical information, contact your local Sales Office or log on to:

www.enardo.com

KEY	QUANTITY	PART NAME	PART NUMBER
1	1	Base, Hatch	4501102
2	1	Disk, Pallet	8559029
3	1	Gasket, Vacuum	See Table 3
4	1	Seal Support	8554636
5	1	Gasket, Envelope	See Table 2
6	1	Spring, Vacuum	See Table 5
7	1	Spring, Pressure	See Table 4
8	1	Pin, Cotter, 1/8 in. x 1 in.	2022101
9	1	Center	4501055
10	1	Stem	8568824
11	1	O-ring, 010	2012710
12	1	Nut, 3/8 – 16 in. Hex Nylock	2059201
13	1	Lid	4522100
14	1	Latch	4524200
15	1	Pin, Latch	4505103
16	2	Clip, Hinge Pin	2027100
17	1	Pin, Clevis, 5/16 in. x 2 5/8 in.	4505118
18	2	Pin, Cotter, 1/8 in. x 1 1/2 in.	2000703
19	1	Pin, Clevis, 5/16 in. x 3 1/2 in.	4505113
20	2	Bushing	8600403
21	2	Spring, Hinge	4504006
22	1	Nut, 1/4 – 20 in. (Optional)	2013322
23	1	Bonding Strap (Optional)	2050006
24	1	Washer, Lock 1/4 in. (Optional)	2012560
25	1	Screw, 1/4 in. – 20 x 1 in. (Optional)	2021817
26	1	Washer, Flat, 5/16 in.	2012584
27	1	Nameplate	4501209

Viton® is a mark owned by E. I. du Pont de Nemours and Company.



Figure 1. Enardo ES-665

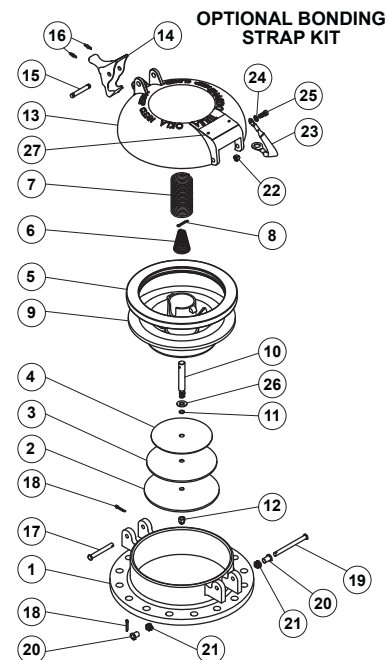

Figure 2. Enardo ES-665 Assembly Drawing

Table 2. Pressure (Envelope) Gasket Options

MATERIAL	PART NUMBER
HNBR (standard)	4504601
Blue Viton*	4504603
Fluorosilicone	4504605

Table 3. Vacuum Gasket Options

MATERIAL	PART NUMBER
Fluorosilicone (standard)	4504705
Blue Viton*	4504708

Table 4. Pressure Spring Options

SETTING, OZ./SQ. IN.	MATERIAL	COLOR 1	COLOR 2	PART NUMBER
4	H.D. Steel (Galvanized)	Dark Green	Dark Green	4502300
6	H.D. Steel (Galvanized)	Brown	Brown	4502500
8	H.D. Steel (Galvanized)	Orange	Orange	4502700
12	H.D. Steel (Galvanized)	Pink	Pink	4502900
16	H.D. Steel (Galvanized)	Dark Blue	Dark Blue	4503100
24	Music Wire	Red	Red	4503300
32	H.D. Steel (Galvanized)	Purple	Purple	4503201
4	Inconel*	Dark Green	White	4502400
6	Inconel*	Brown	White	4502600
8	Inconel*	Orange	White	4502800
12	Inconel*	Pink	White	4503000
16	Inconel*	Dark Blue	White	4503200
24	Inconel*	Red	White	4503400
32	Inconel*	Purple	White	4503600

Table 5. Vacuum Spring Options

SETTING, OZ./SQ. IN.	MATERIAL	COLOR 1	COLOR 2	PART NUMBER
0.4	H.D. Steel (Galvanized)	Light Blue	Light Blue	4503700
0.9	Music Wire	Gray	Gray	4504100
3.5	H.D. Steel (Galvanized)	Yellow	Yellow	4503900
0.4	Inconel*	Light Blue	White	4503800
0.9	Inconel*	Gray	White	4504200

Viton* is a mark owned by E. I. du Pont de Nemours and Company.
Inconel* is a mark owned by Special Metals Corporation.

NOTES:

Tank Blanketing and Vapor Recovery Regulators

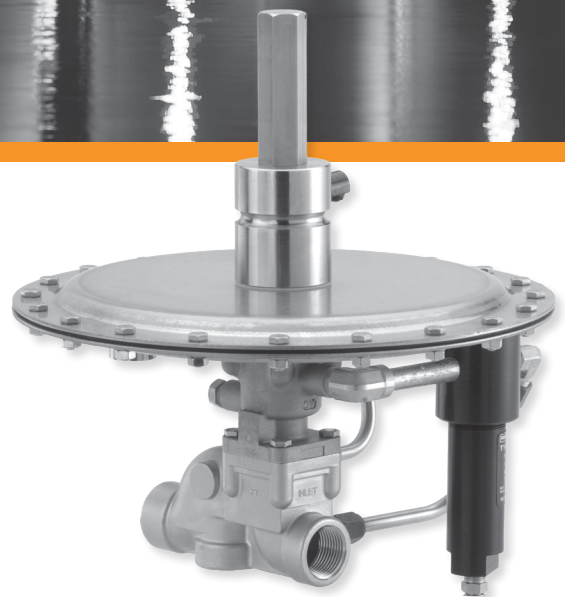

Tank Blanketing and Vapor Recovery Applications



Tank blanketing is a method of controlling vapor pressure in a liquid storage tank. The main purpose of tank blanketing is to prevent air and moisture from entering the tank. The tank blanketing process may be used with positive and negative tank pressure.

Tank Blanketing with Positive Pressure

Gas blanketing and vapor recovery are two techniques that can safely and effectively put a cap on volatile vapors in tanks and other process vessels, thus keeping them from escaping into the atmosphere. There are nearly two hundred volatile and hazardous pollutants that must be controlled to prevent the emission of vapors during storage, handling and processing operations.

The combination of gas blanketing and vapor recovery devices maintains a constant pressure in the tank's vapor space above stored liquid. As a result, tanks containing volatile vapors can "breathe" during pumping operations or if the ambient temperature changes (causing the vapor to expand or contract).

Tank Blanketing (Also Called Pad)

"Tank Blanketing" or "Padding" allows the use of a low-pressure blanket of gas, such as nitrogen, to maintain a

protective gaseous environment above any liquid stored in a tank or vessel. The low-pressure gas blanket fills the void vapor space above the liquid stored in the tank. A gas blanketing system reduces the high-pressure source of gas to a lower pressure forming a blanket over the liquid. Low-pressure blanketing systems commonly protect tanks containing volatile organic liquids.

The positive pressure gas blanket helps prevent outside air, moisture and other contaminants from entering the storage tank. In addition, the positive pressure of the system provides a head pressure above the liquid to reduce vapor loss, which helps protect the tank from corrosion. Storage vessels without adequate protection against corrosion or contamination can cause serious problems if left unattended.

When the tank suddenly cools, the vapors inside condense causing the tank pressure to decrease. This causes the regulator to open which allows the blanketing gas into the tank. Blanketing regulators also maintain a constant tank pressure while removing liquid from the tank. The positive pressure prevents the tank from collapsing.

Tank Blanketing and Vapor Recovery Applications

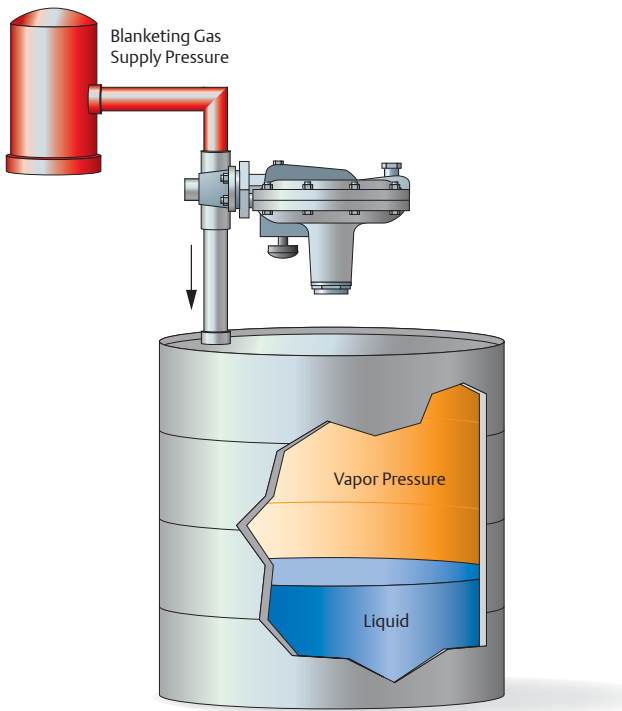

Figure 1. Tank Blanketing (Padding). When the vapor pressure in the tank drops below preset limits, the regulator diaphragm moves the valve disk away from the seat, allowing blanketing gas to flow in.

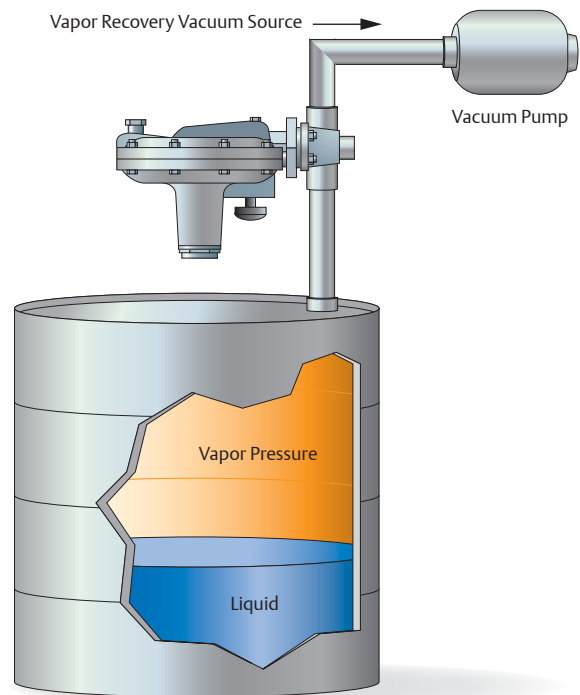

Figure 2. Vapor Recovery (Depadding). In vapor-recovery applications, the regulator moves the valve disk away from the seat in response to high vapor pressures, allowing excess vapor to flow out of the tank.

Inlet pressures at the regulator typically range up to 300 psig / 20.7 bar and the blanketing system's set pressure is normally 2 in. w.c. / 5 mbar or less. The set pressure is kept as low as possible to minimize consumption of blanketing gas.

Vapor Recovery (Also Called Depad)

When pressure inside the vessel rises due to thermal heating or "pump-in" of product, the vapor recovery regulator senses an increase in tank pressure and vents excessive tank pressure to an appropriate vapor-recovery disposal or reclamation system.

Vapor recovery systems have several applications, but the most common reason for installing a system is to prevent vapors from escaping into the atmosphere (some vapors can be vented directly to atmosphere).

Setpoints for vapor recovery systems are typically higher than the blanketing system setpoint to minimize consumption of the blanketing gas. Emergency vents are installed to protect the tank from an upset condition, but these function only in the event of regulator failure or other emergency condition.

Tank Blanketing and Vapor Recovery Valve Types

There are two main types of valves used in positive pressure tank blanketing systems: direct-operated and pilot-operated. Direct-operated valves for blanketing sense the tank's vapor pressure, and this pressure registers directly on the valve diaphragm. When the tank's vapor pressure decreases below the system's setpoint, the spring moves the valve disk away from its seat, allowing gas to flow into the tank.

The position of the disk relative to the seat regulates the amount of flow. Variable-flow control is called throttling. Here, as vapor pressure in the tank increases, the disk moves closer to the seat and shuts off the flow completely when the pressure rises above the setpoint. Direct-operated systems respond quickly to changes in tank pressure. In vapor recovery, the action of the direct-operated valve is reversed. When the tank's vapor pressure rises above the setpoint, the valve's disk moves away from the seat, allowing the vapor to flow out of the tank. Thus, the higher the pressure buildup above setpoint, the more the disk moves and the greater the flow. The valve shuts off the flow of escaping gas when the vapor pressure in the tank is reduced below the setpoint.

Tank Blanketing and Vapor Recovery Applications



In pilot-operated valves for blanketing, a pilot valve opens in response to a lower tank pressure, and a loading pressure is loaded or unloaded to the main valve to open it. When downstream demand is satisfied, the outlet pressure increases slightly, thus acting on the diaphragms of the pilot and main valves. Then, the pilot diaphragm moves to close the pilot valve plug, and the loading pressure to the main valve is reduced or increased, allowing it to shutoff. Small changes in vapor pressure in the tank are amplified by the pilot valve, resulting in very accurate pressure control of the gas-vapor blanket.

Pilot-operated systems for vapor recovery utilize components similar to those used for blanketing, but the action is reversed. In this case, supply pressure is equalized on both sides of the main valve's diaphragm. When the tank's vapor pressure reaches the pilot setpoint, it begins to open and unload the supply pressure from one side of the main valve diaphragm. The resulting pressure imbalance allows the main valve to then open.

Selecting a System

In general, direct-operated tank blanketing and vapor recovery valves respond faster and are typically less expensive to purchase, install and maintain. A direct-operated valve should be the first choice if it meets the capacity and accuracy requirements of the system.

Pilot-operated blanketing and vapor-recovery systems may have lower setpoints and greater accuracy than direct-operated systems. Pilot-operated systems are used when the allowable change in controlled pressure is small or if flow capacities are large. They are also the choice if the body size of the valve is larger than two inches. Pilot-operated systems are the best choice where accuracy and capacity are of prime importance.

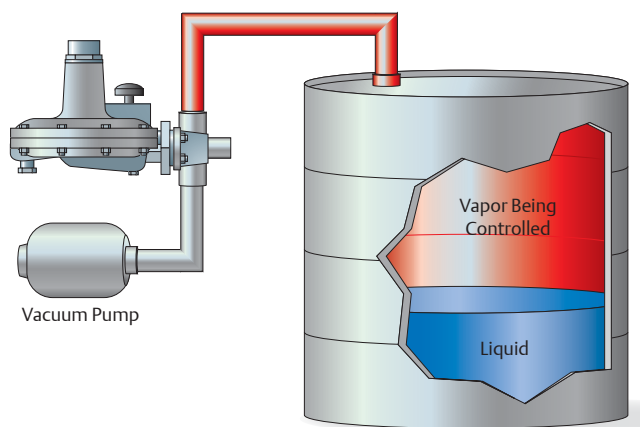

Figure 3. Vacuum Regulator

Tank Blanketing in a Vacuum (Negative Pressure)

When applications arise where the gas blanketing requirements are in vacuum, a combination of a vacuum breaker and a vacuum regulator may be used. Vacuum blanketing is used to prevent vessel leakage to atmosphere when the vapors inside the vessel are harmful. If leakage were to occur, outside air would enter the vessel because of the vacuum in the tank. Therefore, any process vapors in the tank would be contained.

There is a variety of terms used to describe vacuum, causing confusion when communicating with someone that uses different terminology. Emerson™ uses the following vacuum terminology.

First determine whether the units are in absolute pressure or gauge pressure (0 psig or 0 bar (g) is atmospheric pressure). For example:

- 5 psig / 0.34 bar g vacuum is 5 psi / 0.34 bar below atmospheric pressure
- -5 psig / -0.34 bar g is 5 psi / 0.34 bar below atmospheric pressure
- 9.7 psia / 0.67 bar a is 9.7 psi / 0.67 bar above absolute zero or 5 psi / 0.34 bar below atmospheric pressure (14.7 psia - 5 psi = 9.7 psia or 1.01 bar a - 0.34 bar = 0.67 bar a).

Tank Blanketing and Vapor Recovery Applications

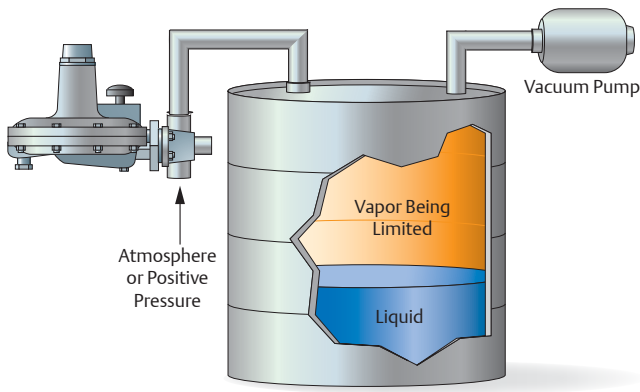

Figure 4. Vacuum Breakers

Just as there are pressure reducing regulators and pressure relief valves for positive pressure service, there are two basic applications for vacuum service. The terms used for each are sometimes confusing. Therefore, it is sometimes necessary to ask further questions to determine the required function of the regulator. The terms vacuum breaker and vacuum regulator are used to differentiate between the two types of Fisher™ regulators.

Vacuum Breakers

Vacuum breakers limit the increase in vacuum. An increase in vacuum (decrease in absolute pressure) beyond the setpoint is sensed on the diaphragm causing the disk to move away from the seat. This permits the higher pressure to enter the system and restore the controlled vacuum to its original pressure setting.

Vacuum Regulators

Vacuum regulators maintain a constant vacuum at the regulator inlet. A decrease in vacuum (increase in pressure) beyond the setpoint registers on the diaphragm causing the disk to move away from the seat, allowing a higher vacuum source to restore the vacuum to its original setting.

Vacuum Applications

Emerson offers several vacuum regulators and vacuum breakers. For specific product information contact your local Sales Office for application solutions.

Tank Blanketing Accessories

Accessories can be added to a valve. The following is a list of accessories that can be added to a tank blanketing or vapor recovery valve to create a system.

First-Stage Regulator

A first-stage regulator is used to reduce a high inlet pressure to a lower pressure before it enters the blanketing valve.

Pressure Gauge

A permanently installed gauge is placed downstream of the first-stage regulator, on the outlet of the regulator or on the control line connection. These gauges are used to monitor the system and check performance, monitor start-up and make adjustments.

Control Line Purge

The purge flowmeter maintains a very small continued flow of blanketing gas through the control line. This eliminates the backflow of tank vapors into the regulator by constantly sweeping them back to the tank. The purge will protect the valve components against potentially corrosive tank vapors and crystallization of the process.

Main Line Purge

The main line purge serves the same purpose as the control line purge, only it purges tank vapors from the main line. Some systems use both control line and main line purges.

Check Valve

A check valve can be piped to the outlet of the tank blanketing valve. This also prevents backflow from the tank to the valve. A check valve should not be applied to valves with internal pressure registration since it inhibits control.

Diagnostics

A diagnostic port provides the capability to analyze the valve's operation in the field, making servicing simpler and more reliable. This is available on the Types ACE95 and ACE95Sr.

Tank Blanketing and Vapor Recovery Applications

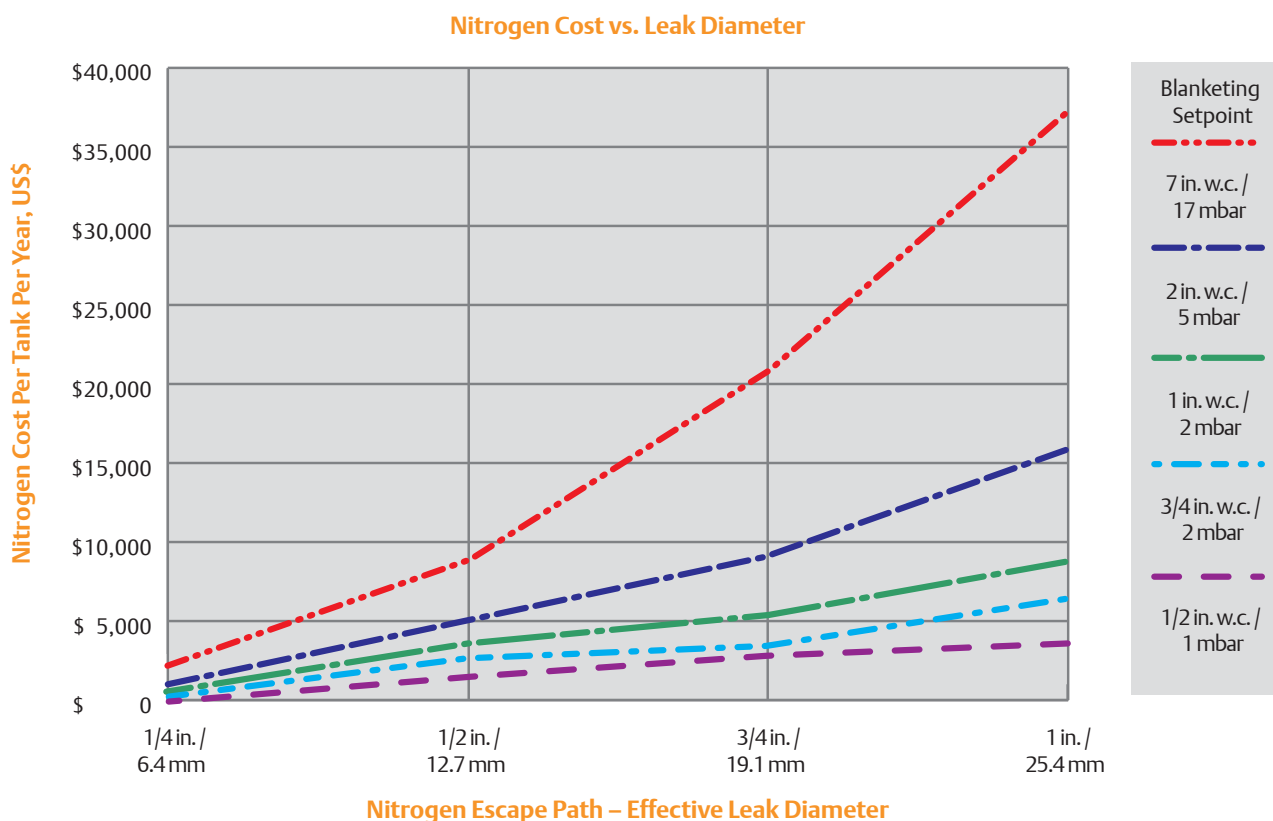

Figure 5. Annual Savings from a 1/4 in. w.c. / 0.62 mbar Setpoint Versus Higher Setpoints. Reduce your gas blanketing expense with low-setpoint technology. This chart shows the incremental annual expense of nitrogen where blanketing setpoints are greater than 1/4 in. w.c. / 0.62 mbar.

Saving Nitrogen

Plant utility managers, tank farm managers and those with storage vessel maintenance responsibilities can easily reduce their gas blanketing expense by using low-setpoint technology.

Low-setpoint tank blanketing valves allow storage vessel operators to maintain a 1/4 in. w.c. / 0.62 mbar setpoint for blanketing gas. Such low blanketing pressures minimize blanketing gas losses by reducing the volume of gas being forced through poorly sealed breather vents and incidental escape paths. The cumulative effect of using the low-setpoint technology of Fisher™ regulators can result in significant savings.

Escape Paths Lead to Loss

In a typical storage vessel, numerous escape paths, pinholes and seal leaks equal to just 1 in. in diameter will result in

up to \$8,683 of nitrogen gas loss when tank pressures are maintained at 1 in. w.c. / 2 mbar versus 1/4 in. w.c. / 0.62 mbar.

How Blanketing Gas is Saved

Escape paths, such as slight roof corrosion or poorly seated vents and pressure/vacuum valves also contribute to blanketing gas consumption. Increased vessel blanketing pressures will cause more gas loss. Decreased pressures, such as 1/4 in. w.c. / 0.62 mbar, minimize nitrogen loss.

Typical Annual Expenses Calculated

The chart shown in Figure 5 demonstrates the typical incremental annual expense of nitrogen lost when using setpoints above 1/4 in. w.c. / 0.62 mbar. To estimate the expense of the annual gas loss, nitrogen was conservatively estimated at US \$2.00/1000 SCFH and validated with a major nitrogen supplier.

Tank Blanketing and Vapor Recovery Applications



Sizing

In order to size a pad or depad application, the user must decide which method is appropriate for the application. Unfortunately, there are few guidelines available. Basically there are two methods in use: direct displacement and API 2000.

The direct displacement method assumes that the volume of product displaced must be replenished by an equal volume of gas. There are no corrections applied for vaporization of product, thermal expansion/contraction or other variables. This method is appropriate for indoor tanks operating at a constant temperature and handling non-flammable product with low vapor pressures. It allows no room for thermal cycling.

The API 2000 method is more complex. It accounts for all of the variables mentioned above. However, it may oversize equipment in many instances. It was developed for tank venting and oversizing was considered to be acceptable.

It is known that some users practice API 2000 sizing, but apply factors to reduce the calculated volumetric requirements. Only the user can decide what is the appropriate method to use for their application.

The blanketing (pad) and venting (depad) valves are system or process operating valves. Supplemental emergency venting should be considered to protect the tank in case of equipment failure, fire exposure or other conditions that would cause the tank pressure to exceed operating limits. The pad and depad valves are not meant to substitute for

emergency tank vents. These vents protect the tank from excessive pressure/vacuum and provide venting for exposure to fire.

Sizing must also take into account applicable codes and standards as they apply to installation.

The reader is encouraged to contact API and obtain a copy of API 2000. (American Petroleum Institute, 1220 L Street, NW, Washington, DC 20005. (202) 682-8000)

Terminology

The term “PAD” refers to the make-up or blanketing of tank vapor space contents to maintain pressure. This is to accommodate the effect of removing liquid from the tank and the effects of ambient cooling of the tank.

The term “DEPAD” refers to venting the tank vapor space contents to limit pressure. This is to accommodate the effect of adding liquid into the tank and the effect of warming the tank contents.

Sizing Method

Significant undersizing is undesirable in that it can result in having a higher than desired pressure when depadding (venting). If the pad (blanketing) valve is undersized it can result in the tank pressure dropping too low and the atmospheric vacuum vent opening. This would allow atmospheric air and moisture into the vapor space. A grossly oversized pad valve could cause overshooting the setpoint, but it is less likely. Pad valves are more tolerant of oversizing than depad valves.

Gross oversizing the depad, however, can result in having the vapor space pressure drop too far below depad setpoint and cause the pad valve to actuate. This is interaction. Oversizing can also increase the cost of the system and result in unnecessary cycling.

When very large tanks are used, the thermal component flow portion of the API methods can be significantly larger than the displacement flow. This means that under conditions of displacement only (no thermal requirement), the valve may be oversized.

Tank Blanketing and Vapor Recovery Applications

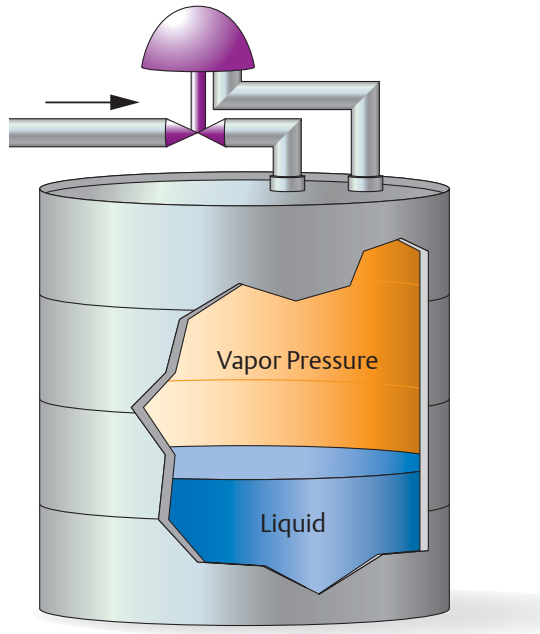

Control Line Installation Tips

Control line should slope downward toward the tank to prevent condensation buildup.

- Make the control line as short and straight as possible.
- Connect the control line to the point where the pressure is to be controlled.
- Increase 1 pipe size for every 10 ft / 3.05 m of control line, with setpoint less than 5 in. w.c. / 12 mbar.

The depad valve is sized on a differential pressure, which is tank pressure (set pressure + buildup) minus the outlet pressure which is typically a vacuum. Using this information, estimates can be made of the resulting operating pressure of the system, at any flow rate, with any size valve. You can simply look at the capacity tables and determine the differential pressure that would result at a given flow rate. Sizing could maintain a lower pressure under most conditions and a higher pressure under 100% flow conditions. This information could be useful in sizing and could result in a reduced installed cost. *Caution must be exercised to maintain the tank operating pressure within allowable limits under all conditions.*

Oversizing of the depad valve can (but will not always) result in the pressure dropping enough, when the depad opens, to enter the pad pressure region. It is for this reason that we require a deadband between the pad and depad operating points. In the case of a displacement flow being significantly less than the thermal portion it may be wise to increase the deadband. Alternately, the depad C_v may be reduced and the tank pressure allowed to rise higher under thermal flow conditions. This modification would require a close examination of the system capabilities including the tank maximum allowable working pressure (MAWP) and the atmospheric vent settings.

Fisher T205 Series

Tank Blanketing Regulator

Introduction

The Fisher™ T205 Series tank blanketing regulators are direct-operated and spring-loaded regulators. The regulator prevents a stored liquid from vaporizing into the atmosphere, reduces liquid combustibility and prevents oxidation or contamination of the product by reducing its exposure to air. The Fisher T205 Series maintains a slightly positive pressure and thereby reduces the possibility of tank wall collapse during pump out operation. The Fisher T205 Series is available in two configurations: Fisher Type T205 for internal pressure registration and Fisher Type T205M for external pressure registration.

Body Sizes and End Connection Styles

See Table 1

Maximum Allowable Inlet Pressure

See Table 1

Maximum Operating Inlet Pressure

See Table 2

Maximum Outlet (Casing) Pressure

Gray cast iron: 35 psig / 2.4 bar
WCC Carbon steel or CF8M/CF3M Stainless steel: 75 psig / 5.2 bar

Maximum Emergency Outlet Pressure to Avoid Internal Parts Damage

With Nitrile (NBR) or Fluorocarbon (FKM) diaphragm: 35 psig / 2.4 bar
With Fluorinated Ethylene Propylene (FEP) diaphragm: 10 psig / 0.69 bar

Outlet (Control) Pressure Range

See Table 3

Shutoff Classification per ANSI/FCI 70-3-2004

Class VI (Soft Seat)

Pressure Registration

Fisher Type T205: Internal
Fisher Type T205M: External

Orifice Size and Flow Coefficients

See Table 5

Body and Casing Materials

Gray cast iron, WCC Carbon steel and CF8M/CF3M Stainless steel

Trim Materials

See Table 4

Flow Capacities

See Tables 7 to 10

C_v Coefficients

See Tables 11 and 12

Material Temperature Capabilities

Elastomer Parts

Nitrile (NBR):

-40 to 180°F / -40 to 82°C

Fluorinated Ethylene Propylene (FEP):

-20 to 180°F / -29 to 82°C

Fluorocarbon (FKM):

40 to 300°F / 4 to 149°C

Ethylene Propylene Diene (EPDM):

-20 to 225°F / -29 to 107°C

Perfluoroelastomer (FFKM):

0 to 300°F / -18 to 149°C

Body Materials

Gray Cast Iron:

-20 to 300°F / -29 to 149°C

WCC Carbon steel:

-20 to 300°F / -29 to 149°C

CF8M/CF3M Stainless steel:

-40 to 300°F / -40 to 149°C

Spring Case Vent Connection

1/4 NPT

Diaphragm Case Control Line Connection (Fisher Type T205M)

1/2 NPT

Approximate Weight

17.7 lbs / 8 kg

Additional Technical Data

For more technical information, contact your local Sales Office or log on to:

www.fisher.com

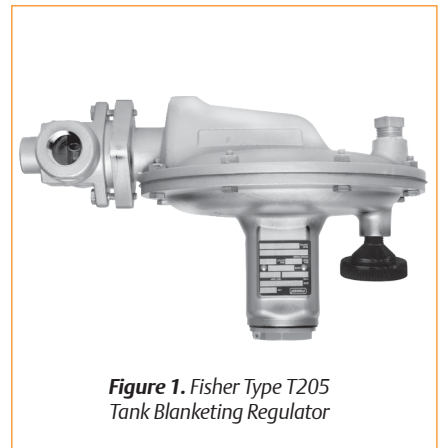

Figure 1. Fisher Type T205 Tank Blanketing Regulator

Features

- Low-pressure Setting and
- Fast Speed of Response
- Accurate Control and Small
- Lockup Pressure
- Multiple Applications
- Corrosion Resistance
- Easy Conversion
- Between Constructions
- Sour Gas Service Capability

Fisher T205 Series

Tank Blanketing Regulator

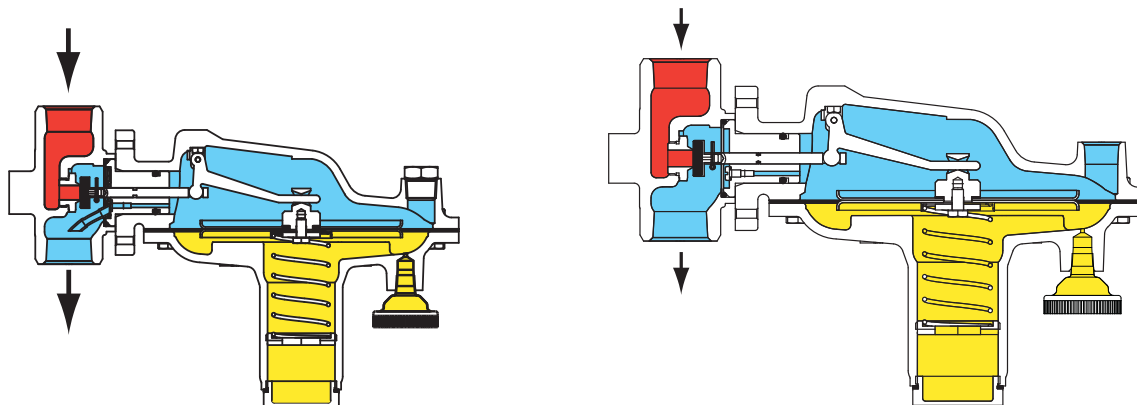

Fisher™ Type T205 with Internal Registration

Fisher Type T205M with External Registration

■ INLET PRESSURE
■ OUTLET PRESSURE
■ ATMOSPHERIC PRESSURE

Figure 2. Fisher T205 Series Operational Schematics

Table 1. Body Sizes, End Connection Styles and Maximum Allowable Inlet Pressure

BODY SIZE		BODY MATERIAL	END CONNECTION STYLES ⁽¹⁾	MAXIMUM ALLOWABLE INLET PRESSURE	
In.	DN			psig	bar
3/4 or 1	20 or 25	Gray Cast Iron	NPT	150	10.3
		WCC Carbon steel	NPT, CL150 RF, CL300 RF or PN 16/25/40 RF	200	13.8
		CF8M/CF3M Stainless steel ⁽²⁾			

1. All flanges are welded. Weld-on flange dimension is 14 in. / 356 mm face-to-face.
2. Pipe nipples and flanges are 316 Stainless steel for flanged body assemblies.

Table 2. Maximum Operating Inlet Pressure

ORIFICE SIZE		MAXIMUM OPERATING INLET PRESSURE													
		1 to 2.5 In. w.c. / 2.5 to 6.2 mbar Outlet (Control) Pressure Setting		2.5 to 7 In. w.c. / 6.2 to 17 mbar Outlet (Control) Pressure Setting		7 to 16 In. w.c. / 17 to 40 mbar Outlet (Control) Pressure Setting		0.5 to 1.2 psig / 34 to 83 mbar Outlet (Control) Pressure Setting		1.2 to 2.5 psig / 83 to 172 mbar Outlet (Control) Pressure Setting		2.5 to 4.5 psig / 0.17 to 0.31 bar Outlet (Control) Pressure Setting		4.5 to 7 psig / 0.31 to 0.48 bar Outlet (Control) Pressure Setting	
In.	mm	psig	bar	psig	bar	psig	bar	psig	bar	psig	bar	psig	bar	psig	bar
3/4 In. / DN 20 Body Size															
1/8	3.2	200 ⁽¹⁾	13.8 ⁽¹⁾	200 ⁽¹⁾	13.8 ⁽¹⁾	200 ⁽¹⁾	13.8 ⁽¹⁾	200 ⁽¹⁾	13.8 ⁽¹⁾	200 ⁽¹⁾	13.8 ⁽¹⁾	200 ⁽¹⁾	13.8 ⁽¹⁾	200 ⁽¹⁾	13.8 ⁽¹⁾
1/4	6.4	125	8.62	175 ⁽¹⁾	12.1 ⁽¹⁾	200 ⁽¹⁾	13.8 ⁽¹⁾	200 ⁽¹⁾	13.8 ⁽¹⁾	200 ⁽¹⁾	13.8 ⁽¹⁾	200 ⁽¹⁾	13.8 ⁽¹⁾	200 ⁽¹⁾	13.8 ⁽¹⁾
3/8	9.5	60	4.14	80	5.52	200 ⁽¹⁾	13.8 ⁽¹⁾	200 ⁽¹⁾	13.8 ⁽¹⁾	200 ⁽¹⁾	13.8 ⁽¹⁾	200 ⁽¹⁾	13.8 ⁽¹⁾	200 ⁽¹⁾	13.8 ⁽¹⁾
1/2	13	30	2.07	40	2.76	125	8.62	150	10.3	200 ⁽¹⁾	13.8 ⁽¹⁾	200 ⁽¹⁾	13.8 ⁽¹⁾	200 ⁽¹⁾	13.8 ⁽¹⁾
9/16	14	20	1.38	30	2.07	100	6.89	125	8.62	200 ⁽¹⁾	13.8 ⁽¹⁾	200 ⁽¹⁾	13.8 ⁽¹⁾	200 ⁽¹⁾	13.8 ⁽¹⁾
1 In. / DN 25 Body Size															
1/8	3.2	200 ⁽¹⁾	13.8 ⁽¹⁾	200 ⁽¹⁾	13.8 ⁽¹⁾	200 ⁽¹⁾	13.8 ⁽¹⁾	200 ⁽¹⁾	13.8 ⁽¹⁾	200 ⁽¹⁾	13.8 ⁽¹⁾	200 ⁽¹⁾	13.8 ⁽¹⁾	200 ⁽¹⁾	13.8 ⁽¹⁾
1/4	6.4	100	6.89	150	10.3	150	10.3	150	10.3	200 ⁽¹⁾	13.8 ⁽¹⁾	200 ⁽¹⁾	13.8 ⁽¹⁾	200 ⁽¹⁾	13.8 ⁽¹⁾
3/8	9.5	40	2.76	80	5.52	150	10.3	150	10.3	200 ⁽¹⁾	13.8 ⁽¹⁾	200 ⁽¹⁾	13.8 ⁽¹⁾	200 ⁽¹⁾	13.8 ⁽¹⁾
1/2	13	30	2.07	40	2.76	125	8.62	150	10.3	200 ⁽¹⁾	13.8 ⁽¹⁾	200 ⁽¹⁾	13.8 ⁽¹⁾	200 ⁽¹⁾	13.8 ⁽¹⁾
9/16	14	20	1.38	15	1.03	100	6.89	125	8.62	200 ⁽¹⁾	13.8 ⁽¹⁾	200 ⁽¹⁾	13.8 ⁽¹⁾	200 ⁽¹⁾	13.8 ⁽¹⁾

1. Inlet pressure is limited to 150 psig / 10.3 bar for gray cast iron bodies.

Table 3. Outlet (Control) Pressures and Spring Part Numbers

OUTLET (CONTROL) PRESSURE RANGES		SPRING COLOR	SPRING WIRE DIAMETER		SPRING FREE LENGTH	
In. w.c.	mbar		In.	mm	In.	mm
1 to 2.5 ⁽¹⁾⁽²⁾	2.5 to 6.2 ⁽¹⁾⁽²⁾	Orange	0.072	1.8	3.25	82.6
2.5 to 7 ⁽¹⁾	6.2 to 17 ⁽¹⁾	Red	0.085	2.2	3.63	92.2
7 to 16	17 to 40	Unpainted	0.105	2.7	3.75	95.2
0.5 to 1.2 psig	34 to 83	Yellow	0.114	2.9	4.31	109
1.2 to 2.5 psig	83 to 172	Green	0.156	4.0	4.06	103
2.5 to 4.5 psig	0.17 to 0.31 bar	Light blue	0.187	4.8	3.94	100
4.5 to 7 psig	0.31 to 0.48 bar	Black	0.218	5.5	3.98	101

1. To achieve the published outlet pressure range the spring case must be installed pointing down.
2. Do not use Fluorocarbon (FKM) diaphragm with this spring at diaphragm temperatures lower than 60°F / 16°C.



Fisher T205 Series

Tank Blanketing Regulator

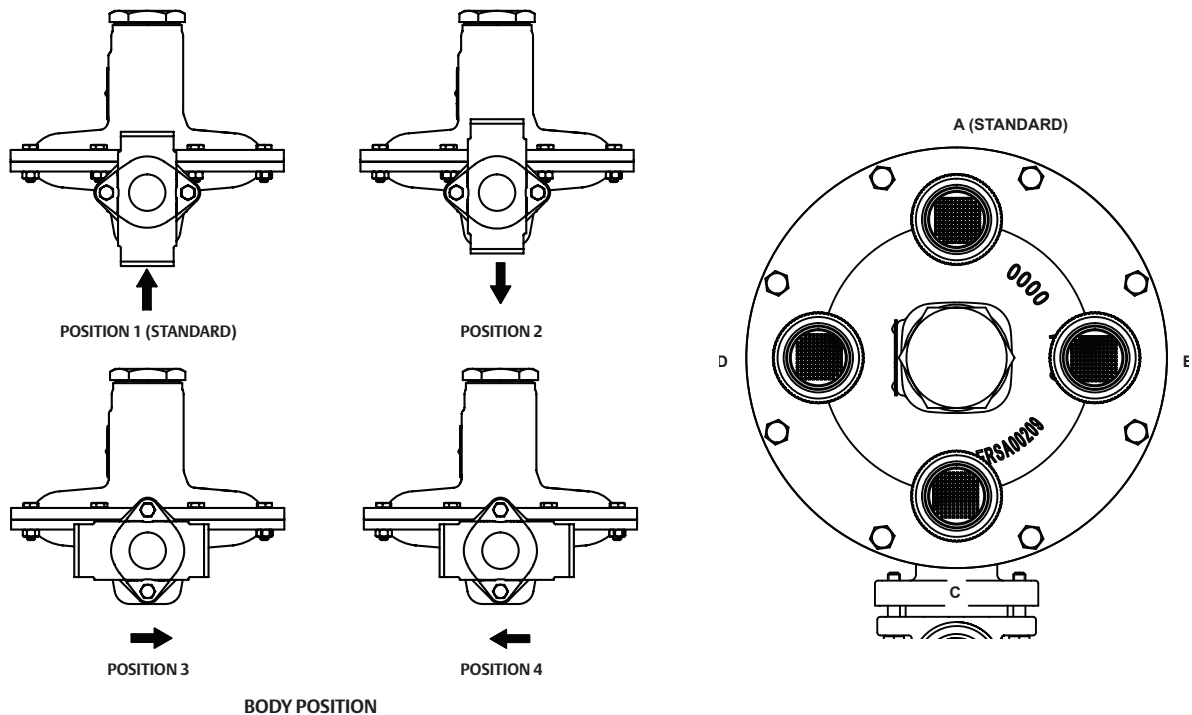

Figure 3. Body and Vent Orientation

Table 4. Trim Materials

BODY AND SPRING CASE	DIAPHRAGM HEAD	LEVER ASSEMBLY	GUIDE INSERT	TRIM OPTION CODE	DIAPHRAGM MATERIAL	DISK AND O-RING MATERIAL	OPERATING TEMPERATURE RANGES
Gray cast iron, WCC Carbon steel or CF8M/CF3M Stainless steel	304 Stainless steel	302 Stainless steel	316 Stainless steel	Standard	Nitrile (NBR)	Nitrile (NBR)	-40 to 180°F / -40 to 82°C
				VV	Fluorocarbon (FKM)	Fluorocarbon (FKM)	40 to 300°F / 4 to 149°C
				TN	Fluorinated Ethylene Propylene (FEP)	Nitrile (NBR)	-20 to 180°F / -29 to 82°C
				TV	Fluorinated Ethylene Propylene (FEP)	Fluorocarbon (FKM)	40 to 180°F / 4 to 82°C
				TK	Fluorinated Ethylene Propylene (FEP)	Perfluoroelastomer (FFKM)	0 to 180°F / -18 to 82°C
				TE	Fluorinated Ethylene Propylene (FEP)	Ethylenepropylene (EPDM)	-20 to 180°F / -29 to 82°C

Table 5. Flow Coefficients

TYPE	ORIFICE SIZE		FLOW COEFFICIENTS (WIDE-OPEN)		C ₁
	In.	mm	C _g	C _v	
T205 and T205M	1/8	3.2	12	0.36	33.3
	1/4	6.4	47	1.40	33.1
	3/8	9.5	101	2.96	34.1
	1/2	13	174	5.20	33.4
	9/16	14	205	6.20	33.1

Table 6. Correction Factors (For Converting Air Flow Rates to Other Gas Flow Rates)⁽¹⁾

BLANKET GAS	SPECIFIC GRAVITY	CORRECTION FACTOR
Natural Gas	0.60	1.291
Nitrogen	0.97	1.015
Dry CO ₂	1.52	0.811

1. For gases of other specific gravities, use equation below.

$$\text{Correction Factor} = \frac{1.00}{\sqrt{SG}}$$

Fisher T205 Series

Tank Blanketing Regulator

Table 7. Flow Capacities of Fisher™ Type T205 with 3/4 in. / DN 20 Body Size

SPRING RANGE AND COLOR	OUTLET PRESSURE SETTING	OFFSET FROM SETPOINT	INLET PRESSURE		CAPACITIES IN SCFH / NM ³ /H OF AIR									
					Orifice Size, In. / mm									
					1/8 / 3.2		1/4 / 6.4		3/8 / 9.5		1/2 / 13		9/16 / 14	
			psig	bar	SCFH	Nm ³ /h	SCFH	Nm ³ /h	SCFH	Nm ³ /h	SCFH	Nm ³ /h	SCFH	Nm ³ /h
1 to 2.5 in. w.c. / 2.5 to 6.2 mbar Orange	1 in. w.c. / 2.5 mbar	1 to 2 in. w.c. / 2.5 to 5.0 mbar	1	0.07	74	1.98	215	5.76	315	8.44	584	15.7	565	15.1
			10	0.69	280	7.50	813	21.8	966	25.9	1301	34.9	1325	35.5
			20	1.4	411	11.0	1190	31.9	1352	36.2	1707	45.7	1173	31.4
			30	2.1	533	14.3	1487	39.9	1575	42.2	1518	40.7		
			60	4.1	877	23.5	1904	51.0	1190	31.9				
			125	8.6	1647	44.1	1637	43.9						
			200	13.8	1452	38.9								
	2 in. w.c. / 5.0 mbar	1 to 2 in. w.c. / 2.5 to 5.0 mbar	1	0.07	70	1.88	212	5.68	279	7.48	442	11.8	466	12.5
			10	0.69	282	7.56	808	21.7	919	24.6	1250	33.5	1259	33.7
			20	1.4	415	11.1	1165	31.2	1334	35.8	1217	32.6	1047	28.1
			30	2.1	540	14.5	1503	40.3	1529	41.0	1204	32.3		
			60	4.1	875	23.4	1885	50.5	2346	62.9				
			125	8.6	1662	44.5	1564	41.9						
			200	13.8	1472	39.4								
2.5 to 7 in. w.c. / 6.2 to 17 mbar Red	2.5 in. w.c. / 6.2 mbar	1 to 2 in. w.c. / 2.5 to 5.0 mbar	1	0.07	69	1.85	124	3.32	236	6.32	318	8.52	332	8.90
			10	0.69	265	7.10	483	12.9	761	20.4	1014	27.2	1121	30.0
			30	2.1	532	14.3	1764	47.3	1411	37.8	1019	27.3	1131	30.3
			40	2.8	653	17.5	1328	35.6	1438	38.5	972	26.0		
			80	5.5	1045	28.0	1672	44.8	1435	38.5				
			175	12.1	1747	46.8	1553	41.6						
			200	13.8	1431	38.4								
	4 in. w.c. / 10 mbar	1 to 2 in. w.c. / 2.5 to 5.0 mbar	1	0.07	66	1.77	115	3.08	161	4.31	266	7.13	264	7.08
			10	0.69	205	5.49	517	13.9	706	18.9	976	26.2	1175	31.5
			30	2.1	504	13.5	1655	44.4	1380	37.0	1794	48.1	1035	27.7
			40	2.8	643	17.2	1448	38.8	1474	39.5	1570	42.1		
			80	5.5	1095	29.3	1747	46.8	1389	37.2				
			175	12.1	1725	46.2	1628	43.6						
			200	13.8	1545	41.4								
	7 in. w.c. / 17.4 mbar	2 to 2 in. w.c. / 5.0 to 5.0 mbar	1	0.07	71	1.90	137	3.67	253	6.78	332	8.90	333	8.92
			10	0.69	268	7.18	723	19.4	938	25.1	1299	34.8	1362	36.5
			30	2.1	539	14.4	1545	41.4	1483	39.7	2100	56.3	1482	39.7
			40	2.8	644	17.3	1689	45.3	2077	55.7	1726	46.3		
			80	5.5	1134	30.4	2704	72.5	2442	65.4				
			175	12.1	1672	44.8	1720	46.1						
			200	13.8	1598	42.8								
7 to 16 in. w.c. / 17 to 40 mbar Unpainted	8 in. w.c. / 20 mbar	2 to 2 in. w.c. / 5.0 to 5.0 mbar	1	0.07	62	1.66	146	3.91	192	5.15	233	6.24	314	8.42
			20	1.4	390	10.5	980	26.3	1241	33.3	1647	44.1	1550	41.5
			100	6.9	1318	35.3	2699	72.3	2077	55.7	2277	61.0	2872	77.0
			125	8.6	1602	42.9	1635	43.8	3029	81.2	2155	57.8		
			200	13.8	1462	39.2	1806	48.4	1160	31.1				
	12 in. w.c. / 30 mbar	20% Gauge	1	0.07	83	2.22	105	2.81	213	5.71	246	6.59	223	5.98
			20	1.4	387	10.4	979	26.2	1228	32.9	1727	46.3	1545	41.4
			100	6.9	1288	34.5	2645	70.9	2123	56.9	2387	64.0	2779	74.5
			125	8.6	1565	41.9	1732	46.4	3066	82.2	2314	62.0		
			200	13.8	2498	66.9	2010	53.9	1387	37.2				
	16 in. w.c. / 40 mbar	20% Gauge	1	0.07			110	2.95	197	5.28	222	5.95	236	6.32
			2	0.14	96	2.57	234	6.27	375	10.0	470	12.6	524	14.0
			20	1.4	377	10.1	1050	28.1	1315	35.2	1653	44.3	1752	47.0
			100	6.9	1322	35.4	2620	70.2	2139	57.3	2816	75.5	2967	79.5
			125	8.6	1609	43.1	2845	76.2	3162	84.7	2590	69.4		
			200	13.8	2459	65.9	2496	66.9	3469	93.0				

 - Black areas indicate where desired flow capacity is not obtainable for a given inlet pressure.
 - Shaded areas indicate where maximum operating inlet pressure for a given orifice size is exceeded.

- continued -



Fisher T205 Series

Tank Blanketing Regulator

Table 7. Flow Capacities of Fisher™ Type T205 with 3/4 in. / DN 20 Body Size (continued)

SPRING RANGE AND COLOR	OUTLET PRESSURE SETTING	OFFSET FROM SETPOINT	INLET PRESSURE		CAPACITIES IN SCFH / NM ³ /H OF AIR									
					Orifice Size, In. / mm									
					1/8 / 3.2		1/4 / 6.4		3/8 / 9.5		1/2 / 13		9/16 / 14	
					psig	bar	SCFH	Nm ³ /h	SCFH	Nm ³ /h	SCFH	Nm ³ /h	SCFH	Nm ³ /h
0.5 to 1.2 psig / 34 to 83 mbar Yellow	0.58 psig / 40 mbar	20% Gauge	2	0.14	115	3.08	216	5.79	357	9.57	459	12.3	476	12.8
			45	3.1	666	17.8	1957	52.4	1571	42.1	2117	56.7	2885	77.3
			125	8.6	1590	42.6	1925	51.6	2685	72.0	2155	57.8	3075	82.4
			150	10.3	1875	50.2	2012	53.9	3031	81.2	2144	57.5		
			200	13.8	2517	67.5	1982	53.1	2586	69.3				
	1 psi / 69 mbar	20% Gauge	2	0.14	108	2.89	265	7.10	401	10.7	521	14.0	528	14.2
			30	2.1	544	14.6	1478	39.6	1802	48.3	2203	59.0	2236	59.9
			125	8.6	1667	44.7	2193	58.8	3364	90.2	2937	78.7	3409	91.4
			150	10.3	1976	53.0	3339	89.5	3608	96.7	2912	78.0		
			200	13.8	2562	68.7	2634	70.6	3748	100				
1.2 to 2.5 psig / 83 to 172 mbar Green	1.2 psi / 83 mbar	20% Gauge	4	0.28	120	3.22	264	7.08	406	10.9	572	15.3	578	15.5
			30	2.1	439	11.8	1074	28.8	1442	38.6	1558	41.8	1978	53.0
			125	8.6	1462	39.2	3128	83.8	2207	59.1	2973	79.7	3341	89.5
			200	13.8	2501	67.0	3873	104	3538	94.8	2782	74.6	3445	92.3
			200	13.8	2501	67.0	3873	104	3538	94.8	2782	74.6	3445	92.3
	2.5 psi / 172 mbar	20% Gauge	6	0.41	159	4.26	465	12.5	677	18.1	943	25.3	1015	27.2
			60	4.1	864	23.2	2288	61.3	2697	72.3	3216	86.2	3980	107
			125	8.6	1646	44.1	3517	94.3	3539	94.8	3893	104	4118	110
			200	13.8	2528	67.8	4627	124	4158	111	3511	94.1	4515	121
			200	13.8	2528	67.8	4627	124	4158	111	3511	94.1	4515	121
2.5 to 4.5 psig / 0.17 to 0.31 bar Light blue	2.5 psi / 0.17 bar	20% Gauge	4	0.28	128	3.43	209	5.60	335	8.98	466	12.5	487	13.1
			60	4.1	897	24.0	1804	48.3	2474	66.3	2776	74.4	3488	93.5
			125	8.6	1603	43.0	3237	86.8	3392	90.9	3810	102	3847	103
			200	13.8	2493	66.8	3965	106	4060	109	3520	94.3	4138	111
			200	13.8	2493	66.8	3965	106	4060	109	3520	94.3	4138	111
	4.5 psi / 0.31 bar	20% Gauge	8	0.55	194	5.20	416	11.1	714	19.1	992	26.6	1005	26.9
			60	4.1	909	24.4	2201	59.0	3099	83.1	3732	100	4352	117
			125	8.6	1673	44.8	3690	98.9	3862	104	5056	136	5623	151
			200	13.8	2174	58.3	5005	134	4757	127	4826	129	5587	150
			200	13.8	2174	58.3	5005	134	4757	127	4826	129	5587	150
4.5 to 7 psig / 0.31 to 0.48 bar Black	4.5 psi / 0.31 bar	20% Gauge	9	0.62	188	5.04	407	10.9	566	15.2	791	21.2	885	23.7
			60	4.1	753	20.2	1745	46.8	2403	64.4	2785	74.6	3574	95.8
			125	8.6	1390	37.3	3168	84.9	3546	95.0	4202	113	4695	126
			200	13.8	2254	60.4	4232	113	4570	122	4663	125	5029	135
			200	13.8	2254	60.4	4232	113	4570	122	4663	125	5029	135
	7 psi / 0.48 bar	20% Gauge	9	0.62	173	4.64	402	10.8	618	16.6	843	22.6	563	15.1
			60	4.1	849	22.8	2156	57.8	2833	75.9	3687	98.8	4379	117
			125	8.6	1582	42.4	3836	103	4290	115	5945	159	6199	166
			200	13.8	2473	66.3	5153	138	5382	144	6439	173	6514	175
			200	13.8	2473	66.3	5153	138	5382	144	6439	173	6514	175

Shaded areas indicate where maximum operating inlet pressure for a given orifice size is exceeded.

Fisher T205 Series

Tank Blanketing Regulator

Table 8. Flow Capacities of Fisher™ Type T205 with 1 in. / DN 25 Body Size

SPRING RANGE AND COLOR	OUTLET PRESSURE SETTING	OFFSET FROM SETPOINT	INLET PRESSURE		CAPACITIES IN SCFH / Nm³/h OF AIR									
					Orifice Size, In. / mm									
					1/8 / 3.2		1/4 / 6.4		3/8 / 9.5		1/2 / 13		9/16 / 14	
			psig	bar	SCFH	Nm³/h	SCFH	Nm³/h	SCFH	Nm³/h	SCFH	Nm³/h	SCFH	Nm³/h
1 to 2.5 in. w.c. / 2.5 to 6.2 mbar Orange	1 in. w.c. / 2.5 mbar	1 to 2 in. w.c. / 2.5 to 5.0 mbar	1	0.07	88	2.36	334	8.95	611	16.4	950	25.5	1101	29.5
			20	1.4	414	11.1	1587	42.5	2332	62.5	1789	47.9	1836	49.2
			30	2.1	538	14.4	2057	55.1	2104	56.4	1919	51.4		
			40	2.8	668	17.9	1996	53.5	1917	51.4				
			100	6.9	1373	36.8	1759	47.1						
	200	13.8	2552	68.4										
	2 in. w.c. / 5.0 mbar	1 to 2 in. w.c. / 2.5 to 5.0 mbar	1	0.07	95	2.55	332	8.90	599	16.1	890	23.9	1065	28.5
			20	1.4	411	11.0	1569	42.0	2620	70.2	1875	50.2	1736	46.5
			30	2.1	538	14.4	2013	53.9	2060	55.2	1801	48.3		
			40	2.8	676	18.1	1854	49.7	1834	49.2				
100			6.9	1383	37.1	1631	43.7							
200	13.8	2544	68.2											
2.5 to 7 in. w.c. / 6.2 to 17 mbar Red	2.5 in. w.c. / 6.2 mbar	1 to 2 in. w.c. / 2.5 to 5.0 mbar	1	0.07	96	2.57	207	5.55	385	10.3	521	14.0	512	13.7
			15	1.0	352	9.43	1308	35.1	2435	65.3	2190	58.7	2028	54.4
			40	2.8	659	17.7	2232	59.8	2256	60.5	1862	49.9		
			80	5.5	1131	30.3	1655	44.4	2095	56.1				
			150	10.3	1875	50.2	1460	39.1						
			200	13.8	2563	68.7								
	4 in. w.c. / 10 mbar	1 to 2 in. w.c. / 2.5 to 5.0 mbar	1	0.07	101	101	222	5.95	308	8.25	368	9.86	422	11.3
			15	1.0	353	353	1233	33.0	2453	65.7	3468	92.9	2597	69.6
			40	2.8	654	17.5	2503	67.1	4901	131	1881	50.4		
			80	5.5	1102	29.5	1796	48.1	2603	69.8				
			150	10.3	1930	51.7	1444	38.7						
			200	13.8	2438	65.3								
	7 in. w.c. / 17.4 mbar	2 to 2 in. w.c. / 5.0 to 5.0 mbar	1	0.07	77	2.06	252	6.75	384	10.3	571	15.3	693	18.6
			15	1.0	349	9.35	1235	33.1	2403	64.4	2656	71.2	3881	104
			40	2.8	648	17.4	2460	65.9	2229	59.7	1782	47.8		
			80	5.5	1125	30.2	1764	47.3	2172	58.2				
			150	10.3	1902	51.0	1648	44.2						
			200	13.8	2337	62.6								
7 to 16 in. w.c. / 17 to 40 mbar Unpainted	8 in. w.c. / 20 mbar	2 to 2 in. w.c. / 5.0 to 5.0 mbar	1	0.07	67	1.80	245	6.57	253	6.78	497	13.3	510	13.7
			20	1.4	337	9.03	1318	35.3	2674	71.7	2462	66.0	2171	58.2
			100	6.9	1370	36.7	1640	44.0	1961	52.6	1863	49.9	1044	28.0
			125	8.6	1667	44.7	1957	52.4	1831	49.1	895	24.0		
			150	10.3	1958	52.5	1560	41.8	1215	32.6				
			200	13.8	2349	63.0								
	12 in. w.c. / 30 mbar	20% Gauge	1	0.07	81	2.17	242	6.49	204	5.47	421	11.3	465	12.5
			20	1.4	395	10.6	1453	38.9	2381	63.8	2412	64.6	2362	63.3
			100	6.9	1375	36.8	1802	48.3	2041	54.7	1550	41.5	1179	31.6
			125	8.6	1651	44.2	2347	62.9	1274	34.1	1447	38.8		
			150	10.3	1965	52.7	1717	46.0	1303	34.9				
			200	13.8	2534	67.9								
	16 in. w.c. / 40 mbar	20% Gauge	1	0.07	73	1.96	230	6.16	240	6.43	423	11.3	411	11.0
			20	1.4	400	10.7	1317	35.3	2679	71.8	5362	144	5845	157
			100	6.9	1363	36.5	2004	53.7	1785	47.8	1760	47.2	1737	46.6
			125	8.6	1672	44.8	2163	58.0	1630	43.7	1613	43.2		
			150	10.3	1871	50.1	2210	59.2	1707	45.7				
			200	13.8	2418	64.8								

Shaded areas indicate where maximum operating inlet pressure for a given orifice size is exceeded.

- continued -



Fisher T205 Series

Tank Blanketing Regulator

Table 8. Flow Capacities of Fisher™ Type T205 with 1 in. / DN 25 Body Size (continued)

SPRING RANGE AND COLOR	OUTLET PRESSURE SETTING	OFFSET FROM SETPOINT	INLET PRESSURE		CAPACITIES IN SCFH / Nm ³ /h OF AIR									
					Orifice Size, In. / mm									
					1/8 / 3.2		1/4 / 6.4		3/8 / 9.5		1/2 / 13		9/16 / 14	
					psig	bar	SCFH	Nm ³ /h	SCFH	Nm ³ /h	SCFH	Nm ³ /h	SCFH	Nm ³ /h
0.5 to 1.2 psig / 34 to 83 mbar Yellow	0.58 psig / 40 mbar	20% Gauge	2	0.14	104	2.79	302	8.09	417	11.2	589	15.8	656	17.6
			45	3.1	736	19.7	2397	64.2	3961	106	2790	74.8	2279	61.1
			125	8.6	1588	42.6	2831	75.9	1235	33.1	1646	44.1	1737	46.6
			150	10.3	1749	46.9	2269	60.8	908	24.3	989	26.5		
			200	13.8	2197	58.9								
	1 psi / 69 mbar	20% Gauge	2	0.14	108	2.89	272	7.29	393	10.5	631	16.9	739	19.8
			30	2.1	494	13.2	1901	50.9	4067	109	4962	133	3260	87.4
			125	8.6	1528	41.0	3269	87.6	3298	88.4	2525	67.7	2367	63.4
			150	10.3	1678	45.0	3187	85.4			2500	67.0		
			200	13.8	2187	58.6								
1.2 to 2.5 psig / 83 to 172 mbar Green	1.2 psi / 83 mbar	20% Gauge	4	0.28	138	3.70	310	8.31	414	11.1	507	13.6	709	19.0
			30	2.1	490	13.1	1312	35.2	1864	50.0	1986	53.2	7909	212
			125	8.6	1608	43.1	4951	133	4454	119	3343	89.6	3354	89.9
			200	13.8	2135	57.2	2367	63.4	2799	75.0	2729	73.1	4006	107
	2.5 psi / 172 mbar	20% Gauge	6	0.41	187	5.0	494	13.2	786	21.1	1112	29.8	1195	32.0
			60	4.1	897	24.0	3159	84.7	6894	184.8	5840	157	5545	149
			125	8.6	1590	42.6	6389	171.2	4874	130.6	4545	122	4978	133
			200	13.8	2386	63.9	6854	183.7	6117	164	4321	116	4459	120
2.5 to 4.5 psig / 0.17 to 0.31 bar Light blue	2.5 psi / 0.17 bar	20% Gauge	4	0.28	108	2.89	269	7.21	334	8.95	535	14.3	550	14.7
			60	4.1	782	21.0	2046	54.8	3578	95.9	11,836	317	12,955	347
			125	8.6	1428	38.3	6395	171	5114	137	4895	131	5371	144
			200	13.8	2198	58.9	7118	191	6708	180	5094	137	4415	118
	4.5 psi / 0.31 bar	20% Gauge	8	0.55	174	4.7	472	12.6	721	19.3	1142	30.6	1174	31.5
			60	4.1	910	24.4	2553	68.4	5189	139	11,261	302	13,488	361
			125	8.6	1558	41.8	6177	165.5	12,919	346	7482	201	7714	207
			200	13.8	2380	63.8	9791	262.4	8496	228	6937	186	7374	198
4.5 to 7 psig / 0.31 to 0.48 bar Black	4.5 psi / 0.31 bar	20% Gauge	9	0.62	178	4.8	383	10.3	595	15.9	874	23.4	988	26.5
			60	4.1	568	15.2	1773	47.5	3086	82.7	9206	247	11,377	305
			125	8.6	1486	39.8	4809	128.9	12,529	335.8	8487	227	8479	227
			200	13.8	2182	58.5	9751	261.3	9382	251	7948	213	8603	231
	7 psi / 0.48 bar	20% Gauge	9	0.62	150	4.0	412	11.0	644	17.3	896	24.0	1049	28.1
			60	4.1	845	22.6	2231	59.8	3776	101.2	8706	233	10,971	294
			125	8.6	1590	42.6	5404	144.8	12,573	337.0	21,735	582	24,399	654
			200	13.8	2394	64.2	9331	250.1	13,239	355	11,601	311	9264	248

Shaded areas indicate where maximum operating inlet pressure for a given orifice size is exceeded.

Fisher T205 Series

Tank Blanketing Regulator

Table 9. Flow Capacities of Fisher™ Type T205M with 3/4 in. / DN 20 Body Size

SPRING RANGE AND COLOR	OUTLET PRESSURE SETTING	OFFSET FROM SETPOINT	INLET PRESSURE		CAPACITIES IN SCFH / Nm ³ /h OF AIR									
					Orifice Size, In. / mm									
			psig	bar	1/8 / 3.2		1/4 / 6.4		3/8 / 9.5		1/2 / 13		9/16 / 14	
					SCFH	Nm ³ /h	SCFH	Nm ³ /h	SCFH	Nm ³ /h	SCFH	Nm ³ /h	SCFH	Nm ³ /h
1 to 2.5 in. w.c. / 2.5 to 6.2 mbar Orange	1 in. w.c. / 2.5 mbar	-1 to +2 in. w.c. / -2.5 to 5.0 mbar	1	0.07	76	2.04	283	7.58	462	12.4	641	17.2	723	19.4
			10	0.69	290	7.77	1113	29.8	1923	51.5	2535	67.9	2501	67.0
			20	1.4	416	11.1	1652	44.3	3019	80.9	4913	132	4853	130
			30	2.1	538	14.4	2647	70.9	4078	109	6541	175		
			60	4.1	895	24.0	4083	109	7557	203				
			125	8.6	1719	46.1	6455	173						
			200	13.8	2640	70.8								
	2 in. w.c. / 5.0 mbar	-1 to +2 in. w.c. / -2.5 to 5.0 mbar	1	0.07	64	1.72	256	6.86	437	11.7	529	14.2	710	19.0
			10	0.69	287	7.69	1069	28.6	1368	36.7	2073	55.6	2280	61.1
			20	1.4	415	11.1	1595	42.7	2541	68.1	2858	76.6	3839	103
			30	2.1	534	14.3	2038	54.6	3560	95.4	3558	95.4		
			60	4.1	894	24.0	3367	90.2	4921	132				
			125	8.6	1692	45.3	6484	174						
			200	13.8	2625	70.4								
2.5 to 7 in. w.c. / 6.2 to 17 mbar Red	2.5 in. w.c. / 6.2 mbar	-1 to +2 in. w.c. / -2.5 to 5.0 mbar	1	0.07	67	1.80	178	4.77	257	6.89	534	14.3	416	11.1
			10	0.69	267	7.16	622	16.7	782	21.0	1137	30.5	1205	32.3
			30	2.1	490	13.1	1287	34.5	1645	44.1	3249	87.1	1456	39.0
			40	2.8	640	17.2	1390	37.3	1586	42.5	5020	135		
			80	5.5	1038	27.8	1840	49.3	5445	146				
			175	12.1	1571	42.1	8890	238						
			200	13.8	2121	56.8								
	4 in. w.c. / 10 mbar	-1 to +2 in. w.c. / -2.5 to 5.0 mbar	1	0.07	81	2.17	160	4.29	265	7.10	289	7.75	302	8.09
			10	0.69	249	6.67	521	14.0	637	17.1	976	26.2	1057	28.3
			30	2.1	455	12.2	1138	30.5	1424	38.2	1992	53.4	1428	38.3
			40	2.8	565	15.1	1210	32.4	1457	39.0	3542	94.9		
			80	5.5	893	23.9	1548	41.5	2124	56.9				
			175	12.1	1761	47.2	3782	101						
			200	13.8	2191	58.7								
7 in. w.c. / 17.4 mbar	-2 to +2 in. w.c. / -5.0 to 5.0 mbar	1	0.07	69	1.85	182	4.88	308	8.25	358	9.59	507	13.6	
		10	0.69	279	7.48	809	21.7	1091	29.2	1576	42.2	1720	46.1	
		30	2.1	516	13.8	1663	44.6	2603	69.8	4708	126	3955	106	
		40	2.8	641	17.2	2004	53.7	2562	68.7	5000	134			
		80	5.5	1136	30.4	2983	79.9	6144	165					
		175	12.1	2263	60.6	8191	220							
		200	13.8	2565	68.7									
7 to 16 in. w.c. / 17 to 40 mbar Unpainted	8 in. w.c. / 20 mbar	-2 to +2 in. w.c. / -5.0 to 5.0 mbar	1	0.07	60	1.61	188	5.04	230	6.16	314	8.42	295	7.91
			20	1.4	239	6.41	1002	26.9	1327	35.6	1746	46.8	1861	49.9
			100	6.9	1311	35.1	2644	70.9	5222	140	6067	163	5169	139
			125	8.6	1477	39.6	3586	96.1	5536	148	5335	143		
			200	13.8	2330	62.4	6821	183	5039	135				
	12 in. w.c. / 30 mbar	20% Gauge	1	0.07			147	3.94	193	5.17	261	6.99	268	7.18
			2	0.14	97	2.60	264	7.08	364	9.76	260	6.97	521	14.0
			20	1.4	241	6.46	1073	28.8	1438	38.5	1793	48.1	1897	50.8
			100	6.9	1307	35.0	2847	76.3	4232	113	5979	160	5617	151
			125	8.6	1503	40.3	3796	102	6164	165	4959	133		
			200	13.8	2312	62.0	6668	179	6028	162				
	16 in. w.c. / 40 mbar	20% Gauge	1	0.07			146	3.91	199	5.33	272	7.29	325	8.71
			2	0.14	96	2.57	271	7.26	368	9.86	377	10.1	528	14.2
			20	1.4	300	8.04	1060	28.4	1607	43.1	2180	58.4	2380	63.8
			100	6.9	1362	36.5	3347	89.7	5824	156	7573	203	6407	172
			125	8.6	1563	41.9	4419	118	6766	181	7028	188		
			200	13.8	2360	63.2	7865	211	8286	222				

■ - Black areas indicate where desired flow capacity is not obtainable for a given inlet pressure.
 ■ - Shaded areas indicate where maximum operating inlet pressure for a given orifice size is exceeded.

- continued -



Fisher T205 Series

Tank Blanketing Regulator

Table 9. Flow Capacities of Fisher™ Type T205M with 3/4 in. / DN 20 Body Size (continued)

SPRING RANGE AND COLOR	OUTLET PRESSURE SETTING	OFFSET FROM SETPOINT	INLET PRESSURE		CAPACITIES IN SCFH / Nm ³ /h OF AIR									
					Orifice Size, In. / mm									
					1/8 / 3.2		1/4 / 6.4		3/8 / 9.5		1/2 / 13		9/16 / 14	
					psig	bar	SCFH	Nm ³ /h	SCFH	Nm ³ /h	SCFH	Nm ³ /h	SCFH	Nm ³ /h
0.5 to 1.2 psig / 34 to 83 mbar Yellow	0.58 psig / 40 mbar	20% Gauge	2	0.14	103	2.76	257	6.89	325	8.71	343	9.19	2517	67.5
			45	3.1	611	16.4	1722	46.1	2448	65.6	3071	82.3	3940	106
			125	8.6	1530	41.0	3693	99.0	4440	119	6976	187	6172	165
			150	10.3	1821	48.8	4964	133	7252	194	6382	171		
	1 psi / 69 mbar	20% Gauge	2	0.14	80	2.14	254	6.81	377	10.1	558	15.0	397	10.6
			30	2.1	507	13.6	1603	43.0	2272	60.9	3445	92.3	3804	102
			125	8.6	1593	42.7	4699	126	6747	181	9750	261	10,421	279
			150	10.3	1916	51.3	6298	169	8902	239	10,291	276		
1.2 to 2.5 psig / 83 to 172 mbar Green	1.2 psi / 83 mbar	20% Gauge	4	0.28	144	3.86	292	7.83	354	9.49	558	15.0	551	14.8
			30	2.1	230	6.16	1017	27.3	1442	38.6	1875	50.2	2061	55.2
			125	8.6	1341	35.9	3046	81.6	4301	115	6528	175	5965	160
			200	13.8	2011	53.9	4539	122	5542	149	8020	215	7371	198
	2.5 psi / 172 mbar	20% Gauge	6	0.41	179	4.80	481	12.9	604	16.2	984	26.4	1041	27.9
			60	4.1	882	23.6	2597	69.6	3662	98.1	5117	137	5597	150
			125	8.6	1611	43.2	4687	126	6442	173	9048	242	10,720	287
			200	13.8	2499	67.0	6876	184	10,250	275	13,775	369	12,236	328
2.5 to 4.5 psig / 0.17 to 0.31 bar Light blue	2.5 psi / 0.17 bar	20% Gauge	4	0.28	106	2.84	266	7.13	318	8.52	366	9.81	438	11.7
			60	4.1	738	19.8	1691	45.3	2424	65.0	3337	89.4	4945	133
			125	8.6	1377	36.9	3057	81.9	4185	112	6570	176	7354	197
			200	13.8	2109	56.5	4579	123	6288	169	8974	241	9551	256
	4.5 psi / 0.31 bar	20% Gauge	8	0.55	194	5.20	500	13.4	658	17.6	959	25.7	1064	28.5
			60	4.1	899	24.1	2296	61.5	3254	87.2	4719	126	5680	152
			125	8.6	1571	42.1	4272	114	6156	165	9286	249	10,573	283
			200	13.8	2341	62.7	6371	171	10,001	268	13,286	356	12,709	341
4.5 to 7 psig / 0.31 to 0.48 bar Black	4.5 psi / 0.31 bar	20% Gauge	9	0.62	181	4.85	253	6.78	765	20.5	816	21.9	828	22.2
			60	4.1	706	18.9	1715	46.0	3400	91.1	3486	93.4	3191	85.5
			125	8.6	1372	36.8	3001	80.4	6367	171	6258	168	6777	182
			200	13.8	2034	54.5	4813	129	6852	184	9275	249	9521	255
	7 psi / 0.48 bar	20% Gauge	9	0.62	167	4.48	433	11.6	812	21.8	902	24.2	909	24.4
			60	4.1	820	22.0	2138	57.3	4140	111	4442	119	5639	151
			125	8.6	1564	41.9	3884	104	7509	201	8007	215	8976	241
			200	13.8	2401	64.3	5686	152	9206	247	12,386	332	13,032	349

Shaded areas indicate where maximum operating inlet pressure for a given orifice size is exceeded.

Fisher T205 Series

Tank Blanketing Regulator

Table 10. Flow Capacities of Fisher™ Type T205M with 1 in. / DN 25 Body Size

SPRING RANGE AND COLOR	OUTLET PRESSURE SETTING	OFFSET FROM SETPOINT	INLET PRESSURE		CAPACITIES IN SCFH / Nm ³ /h OF AIR									
					Orifice Size, In. / mm									
					1/8 / 3.2		1/4 / 6.4		3/8 / 9.5		1/2 / 13		9/16 / 14	
					psig	bar	SCFH	Nm ³ /h	SCFH	Nm ³ /h	SCFH	Nm ³ /h	SCFH	Nm ³ /h
1 to 2.5 in. w.c. / 2.5 to 6.2 mbar Orange	1 in. w.c. / 2.5 mbar	-1 to +2 in. w.c. / -2.5 to 5.0 mbar	1	0.07	94	2.52	342	9.17	602	16.1	890	23.9	929	24.9
			10	0.69	310	8.31	1077	28.9	1968	52.7	3194	85.6	3679	98.6
			20	1.4	423	11.3	1552	41.6	2949	79.0	5214	140	3462	92.8
			30	2.1	539	14.4	2022	54.2	4017	108	6933	186		
			40	2.8	677	18.1	2483	66.5	5111	137				
			100	6.9	1236	33.1	5332	143						
	200	13.8	2219	59.5										
	1	0.07	81	2.17	325	8.71	507	13.6	828	22.2	952	25.5		
	10	0.69	291	7.80	1067	28.6	1699	45.5	2778	74.5	3604	96.6		
	20	1.4	428	11.5	1504	40.3	2243	60.1	4510	121	3381	90.6		
	30	2.1	545	14.6	2004	53.7	2846	76.3	5646	151				
	40	2.8	662	17.7	2452	65.7	4050	109						
100	6.9	1217	32.6	5192	139									
200	13.8	2184	58.5											
2.5 to 7 in. w.c. / 6.2 to 17 mbar Red	2.5 in. w.c. / 6.2 mbar	-1 to +2 in. w.c. / -2.5 to 5.0 mbar	1	0.07	91	2.44	256	6.86	268	7.18	424	11.4	383	10.3
			15	1.0	341	9.14	938	25.1	1081	29.0	1886	50.5	1210	32.4
			40	2.8	650	17.4	1353	36.3	1582	42.4	2577	69.1		
			80	5.5	897	24.0	2339	62.7	9044	242				
			150	10.3	1628	43.6	7363	197						
			200	13.8	2210	59.2								
	4 in. w.c. / 10 mbar	-1 to +2 in. w.c. / -2.5 to 5.0 mbar	1	0.07	77	2.06	221	5.92	264	7.08	321	8.60	347	9.30
			15	1.0	313	8.39	696	18.7	875	23.4	1205	32.3	1281	34.3
			40	2.8	589	15.8	1244	33.3	1439	38.6	1276	34.2		
			80	5.5	919	24.6	2242	60.1	1718	46.0				
			150	10.3	1419	38.0	3413	91.5						
			200	13.8	2001	53.6								
	7 in. w.c. / 17.4 mbar	-2 to +2 in. w.c. / -5.0 to 5.0 mbar	1	0.07	83	2.22	284	7.61	410	11.0	607	16.3	596	16.0
			15	1.0	325	8.71	1037	27.8	1653	44.3	2467	66.1	1863	49.9
			40	2.8	685	18.4	1871	50.1	2701	72.4	4074	109		
			80	5.5	888	23.8	2950	79.1	6235	167				
			150	10.3	1718	46.0	6567	176						
			200	13.8	2218	59.4								
7 to 16 in. w.c. / 17 to 40 mbar Unpainted	8 in. w.c. / 20 mbar	-2 to +2 in. w.c. / -5.0 to 5.0 mbar	1	0.07	77	2.06	198	5.31	295	7.91	385	10.3	444	11.9
			20	1.4	369	9.89	992	26.6	1545	41.4	2163	58.0	2157	57.8
			100	6.9	1123	30.1	2572	68.9	3761	101	4879	131	2851	76.4
			125	8.6	1419	38.0	4713	126	5937	159	5293	142		
			150	10.3	1681	45.1	5794	155	6001	161				
			200	13.8	2208	59.2								
	12 in. w.c. / 30 mbar	20% Gauge	1	0.07	66	1.77	174	4.66	283	7.58	395	10.6	462	12.4
			20	1.4	343	9.19	1026	27.5	1498	40.1	2439	65.4	2208	59.2
			100	6.9	1125	30.2	2452	65.7	3572	95.7	5630	151	4909	132
			125	8.6	1442	38.6	4534	122	6653	178	4721	127		
			150	10.3	1787	47.9	5560	149	6769	181				
			200	13.8	2251	60.3								
	16 in. w.c. / 40 mbar	20% Gauge	1	0.07	75	2.01	175	4.69	273	7.32	392	10.5	496	13.3
			20	1.4	375	10.0	1198	32.1	1834	49.2	2856	76.5	2740	73.4
			100	6.9	1123	30.1	3187	85.4	5772	155	5722	153	4661	125
			125	8.6	1463	39.2	5002	134	6948	186	4768	128		
			150	10.3	1817	48.7	6426	172	7714	207				
			200	13.8	2203	59.0								

Shaded areas indicate where maximum operating inlet pressure for a given orifice size is exceeded.

- continued -



Fisher T205 Series

Tank Blanketing Regulator

Table 10. Flow Capacities of Fisher™ Type T205M with 1 in. / DN 25 Body Size (continued)

SPRING RANGE AND COLOR	OUTLET PRESSURE SETTING	OFFSET FROM SETPOINT	INLET PRESSURE		CAPACITIES IN SCFH / Nm ³ /h OF AIR									
					Orifice Size, In. / mm									
					1/8 / 3.2		1/4 / 6.4		3/8 / 9.5		1/2 / 13		9/16 / 14	
					psig	bar	SCFH	Nm ³ /h	SCFH	Nm ³ /h	SCFH	Nm ³ /h	SCFH	Nm ³ /h
0.5 to 1.2 psig / 34 to 83 mbar Yellow	0.58 psig / 40 mbar	20% Gauge	2	0.14	115	3.08	297	7.96	435	11.7	541	14.5	545	14.6
			45	3.1	680	18.2	1772	47.5	2248	60.2	3529	94.6	3109	83.3
			125	8.6	1552	41.6	4531	121	6034	162	5451	146	6951	186
			150	10.3	1697	45.5	5057	136	7109	191	7307	196		
			200	13.8	2085	55.9								
	1 psi / 69 mbar	20% Gauge	2	0.14	100	2.68	293	7.85	525	14.1	648	17.4	596	16.0
			30	2.1	507	13.6	1721	46.1	2604	69.8	3287	88.1	3301	88.5
			125	8.6	1332	35.7	5177	139	8135	218	9261	248	10,977	294
			150	10.3	1626	43.6	6099	163	9407	252	10,410	279		
			200	13.8	2221	59.5								
1.2 to 2.5 psig / 83 to 172 mbar Green	1.2 psi / 83 mbar	20% Gauge	4	0.28	136	3.64	349	9.35	348	9.33	585	15.7	634	17.0
			30	2.1	405	10.9	1072	28.7	1387	37.2	1860	49.8	2139	57.3
			125	8.6	1255	33.6	2900	77.7	3722	99.7	5556	149	5846	157
			200	13.8	1846	49.5	4449	119	6213	167	7189	193	4890	131
			6	0.41	191	5.12	521	14.0	765	20.5	1005	26.9	1167	31.3
	2.5 psi / 172 mbar	20% Gauge	60	4.1	837	22.4	2500	67.0	3273	87.7	5680	152	5186	139
			125	8.6	1565	41.9	4270	114	6512	175	10,046	269	10,446	280
			200	13.8	2232	59.8	6593	177	11,421	306	13,394	359	12,786	343
			4	0.28	115	3.08	273	7.32	345	9.25	494	13.2	510	13.7
			60	4.1	776	20.8	1581	42.4	2262	60.6	2710	72.6	3174	85.1
2.5 to 4.5 psig / 0.17 to 0.31 bar Light blue	2.5 psi / 0.17 bar	20% Gauge	125	8.6	1351	36.2	3143	84.2	4001	107	5686	152	5083	136
			200	13.8	1997	53.5	4421	118	7327	196	9291	249	9609	258
			8	0.55	206	5.52	415	11.1	708	19.0	1012	27.1	1070	28.7
			60	4.1	875	23.4	2261	60.6	3573	95.8	4304	115	4989	134
			125	8.6	1662	44.5	4177	112	6565	176	8183	219	9844	264
	4.5 psi / 0.31 bar	20% Gauge	200	13.8	2277	61.0	6487	174	10,233	274	12,388	332	14,093	378
			9	0.62	192	5.15	251	6.73	600	16.1	772	20.7	823	22.1
			60	4.1	802	21.5	1708	45.8	2400	64.3	3265	87.5	3392	90.9
			125	8.6	1336	35.8	3247	87.0	3852	103	5686	152	6346	170
			200	13.8	2036	54.6	4518	121	6915	185	8098	217	8150	218
4.5 to 7 psig / 0.31 to 0.48 bar Black	4.5 psi / 0.31 bar	20% Gauge	9	0.62	184	4.93	455	12.2	575	15.4	900	24.1	936	25.1
			60	4.1	747	20.0	2075	55.6	2916	78.1	4721	127	5075	136
			125	8.6	1593	42.7	3952	106	5454	146	7249	194	8606	231
	7 psi / 0.48 bar	20% Gauge	200	13.8	2257	60.5	5791	155	9592	257	11,706	314	12,938	347

Shaded areas indicate where maximum operating inlet pressure for a given orifice size is exceeded.

Fisher T205 Series

Tank Blanketing Regulator

Table 11. C_v Coefficient of Fisher™ T205 Series with 3/4 in. / DN 20 Body Size

SPRING RANGE AND COLOR	OUTLET PRESSURE SETTING	OFFSET FROM SETPOINT	INLET PRESSURE		C _v COEFFICIENT									
					Orifice Size, In. / mm									
					1/8 / 3.2		1/4 / 6.4		3/8 / 9.5		1/2 / 13		9/16 / 14	
			psig	bar	TYPE									
				T205	T205M	T205	T205M	T205	T205M	T205	T205M	T205	T205M	
1 to 2.5 in. w.c. / 2.5 to 6.2 mbar Orange	1 in. w.c. / 2.5 mbar	-1 to +2 in. w.c. / -2.5 to 5.0 mbar	1	0.07	0.3	0.3	1.0	1.3	1.4	2.1	2.6	2.9	2.5	3.2
			10	0.69	0.4	0.4	1.1	1.5	1.3	2.6	1.8	3.4	1.8	3.4
			20	1.4	0.4	0.4	1.1	1.5	1.2	2.7	1.5	4.4	1.1	4.4
			30	2.1	0.4	0.4	1.0	1.8	1.1	2.7	1.0	4.4		
			60	4.1	0.4	0.4	0.8	1.7	0.5	3.0				
			125	8.6	0.4	0.4	0.4	1.4						
			200	13.8	0.2	0.4								
	1	0.07	0.3	0.3	1.0	1.2	1.3	2.0	2.0	2.4	2.1	3.2		
	10	0.69	0.4	0.4	1.1	1.4	1.2	1.8	1.7	2.8	1.7	3.1		
	20	1.4	0.4	0.4	1.0	1.4	1.2	2.2	1.1	2.5	0.9	3.4		
	30	2.1	0.4	0.4	1.0	1.4	1.0	2.4	0.8	2.4				
	60	4.1	0.4	0.4	0.8	1.4	0.9	1.9						
	125	8.6	0.4	0.4	0.3	1.4								
	200	13.8	0.2	0.4										
2.5 to 7 in. w.c. / 6.2 to 17 mbar Red	2.5 in. w.c. / 6.2 mbar	-1 to +2 in. w.c. / -2.5 to 5.0 mbar	1	0.07	0.3	0.3	0.6	0.8	1.1	1.2	1.5	2.5	1.5	1.9
			10	0.69	0.4	0.4	0.7	0.8	1.0	1.0	1.4	1.5	1.5	1.6
			30	2.1	0.4	0.3	1.2	0.9	0.9	1.1	0.7	2.2	0.8	1.0
			40	2.8	0.4	0.4	0.7	0.8	0.8	0.9	0.5	2.8		
			80	5.5	0.3	0.3	0.5	0.6	0.4	1.7				
			175	12.1	0.3	0.3	0.3	1.4						
			200	13.8	0.2	0.3								
	1	0.07	0.3	0.4	0.5	0.8	0.8	1.3	1.3	1.4	1.3	1.4		
	10	0.69	0.3	0.3	0.7	0.7	0.9	0.9	1.3	1.3	1.6	1.4		
	30	2.1	0.3	0.3	1.1	0.8	0.9	1.0	1.2	1.4	0.7	1.0		
	40	2.8	0.4	0.3	0.8	0.7	0.8	0.8	0.9	2.0				
	80	5.5	0.4	0.3	0.6	0.5	0.4	0.7						
	175	12.1	0.3	0.3	0.3	0.6								
	200	13.8	0.2	0.3										
1	0.07	0.4	0.3	0.7	0.9	1.3	1.6	1.7	1.8	1.7	2.6			
10	0.69	0.4	0.4	1.0	1.1	1.3	1.5	1.8	2.1	1.9	2.3			
30	2.1	0.4	0.4	1.1	1.1	1.0	1.7	1.4	3.2	1.0	2.7			
40	2.8	0.4	0.4	0.9	1.1	1.1	1.4	1.0	2.8					
80	5.5	0.4	0.4	0.9	1.0	0.8	1.9							
175	12.1	0.3	0.4	0.3	1.3									
200	13.8	0.2	0.4											
7 to 16 in. w.c. / 17 to 40 mbar Unpainted	8 in. w.c. / 20 mbar	-2 to +2 in. w.c. / -5.0 to 5.0 mbar	1	0.07	0.3	0.3	0.8	1.0	1.0	1.2	1.2	1.6	1.6	1.5
			20	1.4	0.3	0.2	0.9	0.9	1.1	1.2	1.5	1.6	1.4	1.7
			100	6.9	0.3	0.3	0.7	0.7	0.5	0.7	0.6	1.6	0.8	1.4
			125	8.6	0.3	0.3	0.4	0.8	0.6	1.2	0.5	1.2		
			200	13.8	0.2	0.3	0.3	1.0	0.2	0.7				
	12 in. w.c. / 30 mbar	20% Gauge	1	0.07	0.5	0.6	0.8	1.2	1.1	1.4	1.5	1.3	1.5	
			2	0.14	0.3	0.3	0.8	0.9	1.2	1.3	1.4	0.9	1.6	1.8
			20	1.4	0.3	0.2	0.9	1.0	1.1	1.3	1.5	1.6	1.4	1.7
			100	6.9	0.3	0.3	0.7	0.8	0.5	1.1	0.6	1.6	0.7	1.5
			125	8.6	0.3	0.3	0.4	0.8	0.7	1.3	0.5	1.1		
	200	13.8	0.4	0.3	0.3	1.0	0.2	0.8						
	16 in. w.c. / 40 mbar	20% Gauge	1	0.07	0.7	1.0	1.3	1.3	1.5	1.8	1.6	2.2		
			2	0.14	0.3	0.3	0.8	1.0	1.4	1.3	1.7	1.4	1.9	1.9
			20	1.4	0.3	0.3	0.9	1.0	1.2	1.4	1.5	1.9	1.6	2.1
100			6.9	0.3	0.4	0.7	0.9	0.6	1.5	0.7	2.0	0.8	1.7	
125			8.6	0.4	0.3	0.6	1.0	0.7	1.4	0.6	1.5			
200	13.8	0.4	0.3	0.4	1.1	0.5	1.2							

 - Black areas indicate where desired flow capacity is not obtainable for a given inlet pressure.
 - Shaded areas indicate where maximum operating inlet pressure for a given orifice size is exceeded.

- continued -



Fisher T205 Series

Tank Blanketing Regulator

Table 11. C_v Coefficient of Fisher™ T205 Series with 3/4 in. / DN 20 Body Size (continued)

SPRING RANGE AND COLOR	OUTLET PRESSURE SETTING	OFFSET FROM SETPOINT	INLET PRESSURE		C _v COEFFICIENT									
					Orifice Size, In. / mm									
					1/8 / 3.2		1/4 / 6.4		3/8 / 9.5		1/2 / 13		9/16 / 14	
			psig	bar	TYPE									
		T205	T205M	T205	T205M	T205	T205M	T205	T205M	T205	T205M	T205	T205M	
0.5 to 1.2 psig / 34 to 83 mbar Yellow	0.58 psig / 40 mbar	20% Gauge	2	0.14	0.4	0.4	0.8	0.9	1.3	1.2	1.7	1.2	1.7	1.0
			45	3.1	0.3	0.3	1.0	0.9	0.8	1.2	1.1	1.6	1.5	2.0
			125	8.6	0.3	0.3	0.4	0.8	0.6	0.9	0.5	1.5	0.7	1.4
			150	10.3	0.3	0.3	0.4	0.9	0.5	1.3	0.4	1.2		
	200	13.8	0.4	0.3	0.3	0.9	0.4	0.9						
	1 psi / 69 mbar	20% Gauge	2	0.14	0.5	0.3	1.1	1.1			1.7	1.6	2.2	2.4
			30	2.1	0.4	0.3	1.0	1.1	1.2	1.5	1.5	2.3	1.5	2.6
			125	8.6	0.4	0.3	0.5	1.0	0.7	1.4	0.6	2.1	0.8	2.3
150			10.3	0.4	0.4	0.6	1.2	0.7	1.6	0.5	1.9			
200	13.8	0.4	0.3	0.4	1.1	0.5	1.5							
1.2 to 2.5 psig / 83 to 172 mbar Green	1.2 psi / 83 mbar	20% Gauge	4	0.28	0.3	0.4	0.7			0.7	1.0	0.9	1.4	1.4
			30	2.1	0.3	0.2	0.7	0.7	1.0	1.0	1.1	1.3	1.4	1.6
			125	8.6	0.3	0.3	0.7	0.7	0.5	0.9	0.6	1.4	0.7	1.3
			200	13.8	0.4	0.3	0.6	0.7	0.5	0.8	0.4	1.1	0.5	1.1
	2.5 psi / 0.17 bar	20% Gauge	6	0.41	0.3	0.4	1.0	1.0	1.5	1.3	2.1	2.1	2.2	2.3
			60	4.1	0.3	0.4	0.9	1.1	1.1	1.5	1.3	2.1	1.6	2.3
			125	8.6	0.4	0.4	0.8	1.0	0.8	1.4	0.8	2.0	0.9	2.4
			200	13.8	0.4	0.4	0.7	1.0	0.6	1.4	0.5	2.0	0.6	1.8
2.5 to 4.5 psig / 0.17 to 0.31 bar Light blue	2.5 psi / 0.17 bar	20% Gauge	4	0.28	0.4	0.4	0.7	0.9	1.1	1.1	1.6	1.2	1.6	1.5
			60	4.1	0.4	0.3	0.7	0.7	1.0	1.0	1.1	1.3	1.4	2.0
			125	8.6	0.3	0.3	0.7	0.7	0.7	0.9	0.8	1.4	0.8	1.6
			200	13.8	0.4	0.3	0.6	0.7	0.6	0.9	0.5	1.3	0.6	1.4
	4.5 psi / 0.31 bar	20% Gauge	8	0.55	0.4	0.4	0.9	1.0	1.5	1.4	2.0	2.0	2.1	2.2
			60	4.1	0.4	0.4	0.9	0.9	1.2	1.3	1.5	1.9	1.8	2.3
			125	8.6	0.4	0.3	0.8	0.9	0.8	1.3	1.1	2.0	1.2	2.3
			200	13.8	0.3	0.3	0.7	0.9	0.7	1.4	0.7	1.9	0.8	1.8
4.5 to 7 psig / 0.31 to 0.48 bar Black	4.5 psi / 0.31 bar	20% Gauge	9	0.62	0.3	0.3	0.7	0.5	1.0	1.4	1.4	1.5	1.6	1.5
			60	4.1	0.3	0.3	0.7	0.7	1.0	1.3	1.1	1.4	1.5	1.3
			125	8.6	0.3	0.3	0.7	0.7	0.8	1.4	0.9	1.4	1.0	1.5
			200	13.8	0.3	0.3	0.6	0.7	0.6	0.9	0.7	1.3	0.7	1.4
	7 psi / 0.48 bar	20% Gauge	9	0.62	0.4	0.4	1.0	1.1	1.6	2.1	2.2	2.3	1.4	2.3
			60	4.1	0.3	0.3	0.9	0.9	1.1	1.6	1.5	1.8	1.8	2.3
			125	8.6	0.3	0.3	0.8	0.8	0.9	1.6	1.3	1.7	1.4	2.0
			200	13.8	0.4	0.3	0.7	0.8	0.7	1.3	0.9	1.8	0.9	1.9

Shaded areas indicate where maximum operating inlet pressure for a given orifice size is exceeded.

Fisher T205 Series

Tank Blanketing Regulator

Table 12. C_v Coefficient of Fisher™ T205 Series with 1 in. / DN 25 Body Size

SPRING RANGE AND COLOR	OUTLET PRESSURE SETTING	OFFSET FROM SETPOINT	INLET PRESSURE		C _v COEFFICIENT									
					Orifice Size, In. / mm									
					1/8 / 3.2		1/4 / 6.4		3/8 / 9.5		1/2 / 13		9/16 / 14	
			psig	bar	TYPE									
				T205	T205M	T205	T205M	T205	T205M	T205	T205M	T205	T205M	
1 to 2.5 in. w.c. / 2.5 to 6.2 mbar Orange	1 in. w.c. / 2.5 mbar	-1 to +2 in. w.c. / -2.5 to 5.0 mbar	1	0.07	0.4	0.4	1.5	1.5	2.7	2.7	4.3	4.0	4.9	4.2
			20	1.4	0.4	0.4	1.4	1.4	2.0	2.6	1.6	4.6	1.6	3.1
			30	2.1	0.4	0.4	1.4	1.4	1.4	2.7	1.3	4.7		
			40	2.8	0.4	0.4	1.1	1.4	1.0	2.8				
			100	6.9	0.4	0.3	0.5	1.4						
			200	13.8	0.4	0.3								
	2 in. w.c. / 5.0 mbar	-1 to +2 in. w.c. / -2.5 to 5.0 mbar	1	0.07	0.4	0.4	1.5	1.5	2.7	2.3	4.1	3.8	4.9	4.4
			20	1.4	0.4	0.4	1.4	1.3	2.3	2.0	1.7	4.0	1.6	3.0
			30	2.1	0.4	0.4	1.4	1.4	1.4	1.9	1.2	3.8		
			40	2.8	0.4	0.4	1.0	1.4	1.0	2.2				
			100	6.9	0.4	0.3	0.4	1.4						
			200	13.8	0.4	0.3								
2.5 to 7 in. w.c. / 6.2 to 17 mbar Red	2.5 in. w.c. / 6.2 mbar	-1 to +2 in. w.c. / -2.5 to 5.0 mbar	1	0.07	0.4	0.4	1.0	1.2	1.8	1.2	2.4	2.0	2.4	1.8
			15	1.0	0.4	0.4	1.4	1.0	2.6	1.1	2.3	2.0	2.2	1.3
			40	2.8	0.4	0.4	1.2	0.8	1.2	0.9	1.0	1.4		
			80	5.5	0.4	0.3	0.5	0.8	0.7	2.8				
			150	10.3	0.3	0.3	0.3	1.4						
			200	13.8	0.4	0.3								
	4 in. w.c. / 10 mbar	-1 to +2 in. w.c. / -2.5 to 5.0 mbar	1	0.07	0.5	0.4	1.1	1.0	1.5	1.3	1.7	1.5	2.0	1.6
			15	1.0	0.4	0.3	1.3	0.7	2.6	0.9	3.7	1.3	2.8	1.4
			40	2.8	0.4	0.3	1.4	0.7	2.7	0.8	1.0	0.7		
			80	5.5	0.4	0.3	0.6	0.7	0.8	0.5				
			150	10.3	0.4	0.3	0.3	0.6						
			200	13.8	0.3	0.3								
	7 in. w.c. / 17 mbar	-2 to +2 in. w.c. / -5.0 to 5.0 mbar	1	0.07	0.4	0.4	1.3	1.4	1.9	2.1	2.9	3.1	3.5	3.0
			15	1.0	0.4	0.3	1.3	1.1	2.5	1.7	2.8	2.6	4.2	2.0
			40	2.8	0.4	0.4	1.4	1.0	1.2	1.5	1.0	2.3		
			80	5.5	0.4	0.3	0.6	1.0	0.7	1.9				
			150	10.3	0.4	0.3	0.3	1.2						
			200	13.8	0.3	0.3								
7 to 16 in. w.c. / 17 to 40 mbar Unpainted	8 in. w.c. / 20 mbar	-2 to +2 in. w.c. / -5.0 to 5.0 mbar	1	0.07	0.3	0.4	1.3	1.0	1.3	1.5	2.6	2.0	2.6	2.3
			20	1.4	0.3	0.3	1.2	0.9	2.4	1.4	2.2	1.9	2.0	1.9
			100	6.9	0.4	0.3	0.4	0.7	0.5	1.0	0.5	1.3	0.3	1.3
			125	8.6	0.4	0.3	0.4	1.0	0.4	1.3	0.2	1.2		
			150	10.3	0.4	0.3	0.3	1.1	0.2	1.1				
			200	13.8	0.3	0.3								
	12 in. w.c. / 30 mbar	20% Gauge	1	0.07	0.5	0.4	1.4	1.0	1.2	1.6	2.4	2.3	2.7	2.7
			20	1.4	0.4	0.3	1.3	0.9	2.1	1.3	2.2	2.2	2.1	2.0
			100	6.9	0.4	0.3	0.5	0.7	0.5	0.9	0.4	1.5	0.3	1.3
			125	8.6	0.4	0.3	0.5	1.0	0.3	1.4	0.3	1.0		
			150	10.3	0.4	0.3	0.3	1.0	0.2	1.2				
			200	13.8	0.4	0.3								
	16 in. w.c. / 40 mbar	20% Gauge	1	0.07	0.5	0.5	1.5	1.2	1.6	1.8	2.8	2.6	2.7	3.3
			20	1.4	0.4	0.3	1.2	1.1	2.4	1.6	4.8	2.6	5.3	2.5
			100	6.9	0.4	0.3	0.5	0.9	0.5	1.5	0.5	1.5	0.5	1.2
			125	8.6	0.4	0.3	0.5	1.1	0.3	1.5	0.4	1.0		
			150	10.3	0.3	0.3	0.4	1.2	0.3	1.4				
			200	13.8	0.3	0.3								

Shaded areas indicate where maximum operating inlet pressure for a given orifice size is exceeded.

- continued -



Fisher T205 Series

Tank Blanketing Regulator

Table 12. C_v Coefficient of Fisher™ T205 Series with 1 in. / DN 25 Body Size (continued)

SPRING RANGE AND COLOR	OUTLET PRESSURE SETTING	OFFSET FROM SETPOINT	INLET PRESSURE		C_v COEFFICIENT									
					Orifice Size, In. / mm									
					1/8 / 3.2		1/4 / 6.4		3/8 / 9.5		1/2 / 13		9/16 / 14	
			psig	bar	TYPE									
				T205	T205M	T205	T205M	T205	T205M	T205	T205M	T205	T205M	
0.5 to 1.2 psig / 34 to 83 mbar Yellow	0.58 psi / 40 mbar	20% Gauge	2	0.14	0.4	0.4	1.1	1.1	1.5	1.6	2.1	2.0	2.4	2.0
			45	3.1	0.4	0.3	1.2	0.9	2.0	1.1	1.4	1.8	1.2	1.2
			125	8.6	0.3	0.3	0.6	1.0	0.3	1.3	0.4	1.2	0.4	1.5
			150	10.3	0.3	0.3	0.4	0.9	0.2	1.3	0.2	1.4		
	200	13.8	0.3	0.3										
	1 psi / 69 mbar	20% Gauge	2	0.14	0.5	0.4	1.2	1.3	1.7	2.2	2.7	2.8	3.2	2.5
			30	2.1	0.3	0.3	1.3	1.2	2.7	1.7	3.4	2.2	2.2	2.3
			125	8.6	0.3	0.3	0.7	1.1	0.7	1.7	0.5	2.0	0.5	2.4
			150	10.3	0.3	0.3	0.6	1.1		1.7	0.5	1.9		
			200	13.8	0.3	0.3								
1.2 to 2.5 psig / 83 to 172 mbar Green	1.2 psi / 83 mbar	20% Gauge	4	0.28	0.3	0.3	0.8	0.9	1.0	0.9	1.3	1.5	1.8	1.6
			30	2.1	0.3	0.3	0.9	0.7	1.3	0.9	1.4	1.3	5.4	1.5
			125	8.6	0.4	0.3	1.1	0.6	0.9	0.8	0.7	1.2	0.7	1.3
			200	13.8	0.3	0.3	0.3	0.6	0.4	0.9	0.4	1.0	0.4	0.7
	2.5 psi / 0.17 bar	20% Gauge	6	0.41	0.4	0.4	1.1	1.1	1.7	1.7	2.4	2.2	2.6	2.5
			60	4.1	0.4	0.3	1.3	1.0	2.7	1.3	2.4	2.3	2.3	2.1
			125	8.6	0.3	0.3	1.4	0.9	1.0	1.4	1.0	2.2	1.1	2.3
			200	13.8	0.3	0.3	1.0	0.9	0.8	1.6	0.6	1.9	0.6	1.8
2.5 to 4.5 psig / 0.17 to 0.31 bar Light blue	2.5 psi / 0.17 bar	20% Gauge	4	0.28	0.4	0.4	0.9	0.9	1.1	1.1	1.8	1.6	1.8	1.7
			60	4.1	0.3	0.3	0.8	0.6	1.4	0.9	4.8	1.1	5.3	1.3
			125	8.6	0.3	0.3	1.4	0.7	1.1	0.8	1.1	1.2	1.2	1.1
			200	13.8	0.3	0.3	1.0	0.6	0.9	1.0	0.7	1.3	0.6	1.4
	4.5 psi / 0.31 bar	20% Gauge	8	0.55	0.4	0.4	1.0	0.9	1.5	1.5	2.4	2.1	2.4	2.2
			60	4.1	0.4	0.4	1.0	0.9	2.1	1.4	4.6	1.7	5.5	2.0
			125	8.6	0.3	0.4	1.4	0.9	2.7	1.4	1.6	1.8	1.7	2.2
			200	13.8	0.3	0.3	1.4	0.9	1.2	1.4	1.0	1.8	1.1	2.0
4.5 to 7 psig / 0.31 to 0.48 bar Black	4.5 psi / 0.31 bar	20% Gauge	9	0.62	0.3	0.3	0.7	0.5	1.1	1.1	1.6	1.4	1.8	1.5
			60	4.1	0.2	0.3	0.7	0.7	1.2	1.0	3.7	1.3	4.6	1.4
			125	8.6	0.3	0.3	1.1	0.7	2.7	0.8	1.8	1.2	1.9	1.4
			200	13.8	0.3	0.3	1.4	0.6	1.3	1.0	1.1	1.1	1.2	1.2
	7 psi / 0.48 bar	20% Gauge	9	0.62	0.4	0.5	1.1	1.2	1.7	1.5	2.3	2.3	2.7	2.4
			60	4.1	0.3	0.3	0.9	0.8	1.5	1.2	3.5	1.9	4.5	2.1
			125	8.6	0.3	0.3	1.2	0.9	2.7	1.2	4.7	1.6	5.3	1.9
			200	13.8	0.3	0.3	1.3	0.8	1.8	1.3	1.6	1.7	1.3	1.9

Shaded areas indicate where maximum operating inlet pressure for a given orifice size is exceeded.

Fisher T205 Series

Tank Blanketing Regulator

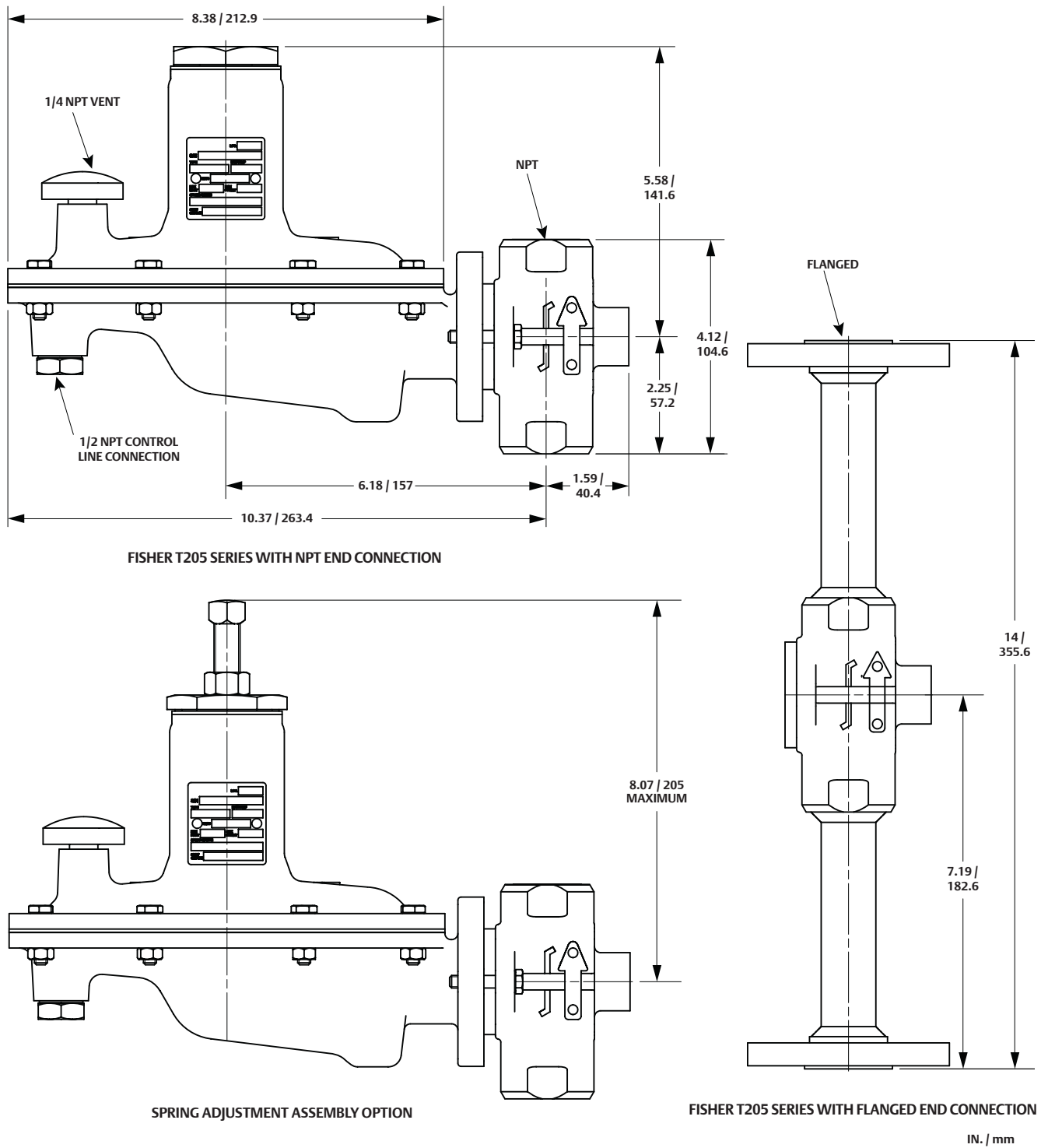

Figure 4. Fisher™ T205 Series Dimensions

Ordering Guide

Type (Select One)

- T205, Internal pressure registration
- T205M, External pressure registration

Body Size (Select One)

- 3/4 in. / DN 20***
- 1 in. / DN 25***

Body Material and End Connection Style (Select One)

Gray Cast Iron

- NPT***

WCC Carbon steel

- NPT***
- CL150 RF**
- CL300 RF*
- PN 16/25/40 RF*, specify rating_____

CF8M/CF3M Stainless steel

- NPT***
- CL150 RF**
- CL300 RF*
- PN 16/25/40 RF*, please specify rating_____

Outlet (Control) Pressure Range (Select One)

- 1 to 2.5 in. w.c. / 2.5 to 6.2 mbar, Orange***
- 2.5 to 7 in. w.c. / 6.2 to 17 mbar, Red***
- 7 to 16 in. w.c. / 17 to 40 mbar, Unpainted***
- 0.5 to 1.2 psig / 34 to 83 mbar, Yellow***
- 1.2 to 2.5 psig / 83 to 172 mbar, Green**
- 2.5 to 4.5 psig / 0.17 to 0.31 bar, Light Blue**
- 4.5 to 7 psig / 0.31 to 0.48 bar, Black**

Orifice Size (Select One)

- 1/8 in. / 3.2 mm***
- 1/4 in. / 6.4 mm***
- 3/8 in. / 9.5 mm***
- 1/2 in. / 13 mm**
- 9/16 in. / 14 mm*

316 Stainless steel Trim Parts (Select one)

- Yes
- No

Trim Material (See Table 5, Select One)

- Standard
- VV
- TN
- TV
- TK
- TE

Adjusting Screw (Select One)

- Internal Flat Circular (standard)***
- External Square Head (Available for Green, Light blue and Black springs only. Steel closing cap is automatically supplied in this option)***

Closing Cap Material (Select One)

- Plastic (standard) (not available for Green, Light blue and Black springs)***
- Steel (standard for Green, Light blue and Black springs)***
- Stainless steel**

Body Position (See Figure 3, Select one)

- Position 1 (standard)***
- Position 2***
- Position 3***
- Position 4***

Spring Case Orientation/Vent Type (Select One)

- Spring Case Sideways (Type Y602-12) **(standard)**
- Spring Case Down (Type Y602-1)
- Spring Case Up (Type Y602-11)

Vent Orientation (See Figure 3, Select one)

- Position A (standard)***
- Position B***
- Position C***
- Position D***

NACE Standard MR0175-2002 Construction (Select one)

- Yes
- No

Replacement Parts Kit (Optional)

- Yes, send one replacement parts kit to match this order.

- continued -

Fisher T205 Series

Tank Blanketing Regulator

Ordering Guide (continued)

To order this product, complete this page or complete the Specification Worksheet and forward to your local Sales Office.

If the construction you need is not offered in the ordering guide section, contact your local Sales Office.

To locate your local Sales Office log on to:
www.fisher.com

Regulators Quick Order Guide	
***	Readily Available for Shipment
**	Allow Additional Time for Shipment
*	Special Order, Constructed from Non-Stocked Parts. Consult your local Sales Office for Availability.
Availability of the product being ordered is determined by the component with the longest shipping time for the requested construction.	

Specification Worksheet
Application
Tank Capacity:
Pump In Rate:
Pump Out Rate:
Blanketing Gas Type:
Blanketing Gas Specific Gravity:
Conservation Vent Setpoint:
Is a vapor recovery regulator required? <input type="checkbox"/> Yes <input type="checkbox"/> No
Pressure
Maximum Inlet Pressure (P_{1max}):
Minimum Inlet Pressure (P_{1min}):
Control Pressure Setting (P_2):
Maximum Flow (Q_{max}):
Performance Required
Accuracy Requirements:
<input type="checkbox"/> 0.25 in. w.c. / 0.6 mbar <input type="checkbox"/> 0.50 in. w.c. / 1 mbar
<input type="checkbox"/> 1 in. w.c. / 2 mbar <input type="checkbox"/> 2 in. w.c. / 5 mbar
<input type="checkbox"/> Others _____
Other Requirements:



The distinctive diamond shape cast into every spring case uniquely identifies the regulator as part of the Fisher™ brand and assures you of the highest-quality engineering, durability, performance and support.

Fisher Type T205B

Tank Blanketing Regulator

Introduction

Tank blanketing is the process of filling the vapor space above the liquid in a low pressure storage tank with a gas (usually nitrogen) and maintaining a slightly positive pressure. Tank blanketing prevents a stored liquid from vaporizing into the atmosphere, reduces liquid combustibility and prevents oxidation or contamination of the liquid by reducing its exposure to air. This process is used in various industries, for products such as oils, chemicals, pharmaceuticals and food and beverages.

The Fisher™ Type T205B balanced tank blanketing regulator is a direct-operated regulator with fully balanced plug design to reduce inlet pressure sensitivity and with a large diaphragm to accurately control tank pressure at low pressure settings on tank blanketing systems. It uses a control line to sense the pressure in a low pressure storage tank. The Fisher Type T205B maintains a slightly positive pressure and thereby reduces the possibility of contamination and tank wall collapse during pump out operation.

Body Size and End Connection Style

See Table 1

Maximum Allowable Inlet Pressure

See Table 1

Maximum Operating Inlet Pressure

Gray Cast iron: 150 psig / 10.3 bar

WCC Carbon steel or CF8M/CF3M

Stainless steel: 200 psig / 13.8 bar

Maximum Outlet (Casing) Pressure

Gray Cast iron: 35 psig / 2.4 bar

WCC Carbon steel or CF8M/CF3M

Stainless steel: 75 psig / 5.2 bar

Maximum Emergency Outlet Pressure to Avoid Internal Parts Damage

With Nitrile (NBR) or Fluorocarbon (FKM) diaphragm: 35 psig / 2.4 bar

With Fluorinated Ethylene Propylene (FEP) diaphragm: 10 psig / 0.69 bar

Outlet (Control) Pressure Range

See Table 2

Pressure Registration

External

Material Temperature Capabilities

Elastomer Parts

Nitrile (NBR):

-40 to 180°F / -40 to 82°C

Fluorinated Ethylene Propylene (FEP):

-20 to 180°F / -29 to 82°C

Fluorocarbon (FKM):

40 to 300°F / 4 to 149°C

Ethylene Propylene Diene (EPDM):

-20 to 225°F / -29 to 107°C

Perfluoroelastomer (FFKM):

0 to 300°F / -18 to 149°C

Body Materials

Gray Cast iron:

-20 to 300°F / -29 to 149°C

WCC Carbon steel:

-20 to 300°F / -29 to 149°C

CF8M/CF3M Stainless steel:

-40 to 300°F / -40 to 149°C

Orifice Size

3/8 in. / 9.5 mm

Body and Casing Materials

Gray cast iron, WCC Carbon steel and CF8M/CF3M Stainless steel

Trim Materials

See Table 3

Spring Case Vent Connection

1/4 NPT

Diaphragm Case Control Line Connection

1/2 NPT

Shutoff Classification per ANSI/FCI 70-3-2004

Class VI (Soft Seat)

Flow and Sizing Coefficients

See Table 4

C_v Coefficients

See Table 8

Flow Capacities

See Table 9

Approximate Weight

17.7 lbs / 8 kg

Additional Technical Data

For more technical information, contact your local Sales Office or log on to:

www.fisher.com

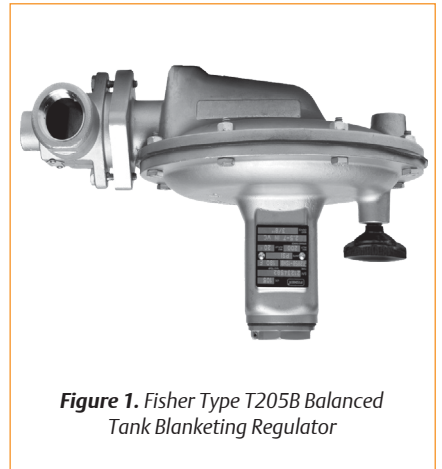

Figure 1. Fisher Type T205B Balanced Tank Blanketing Regulator

Features

- Fully Balanced Plug Design
- Large Diaphragm
- Low-Pressure Setting and Fast Speed of Response
- Accurate Control and Small Lockup Pressure
- Sour Gas Service Capability

Fisher Type T205B

Tank Blanketing Regulator

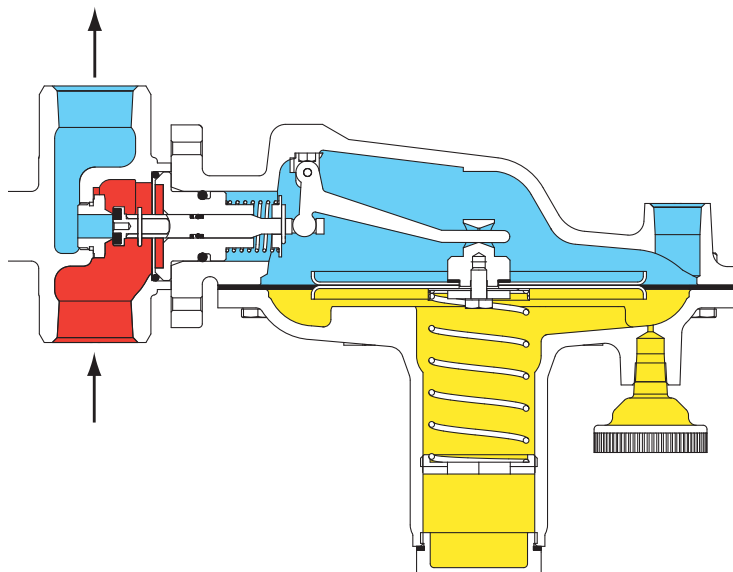

M1220

- INLET PRESSURE
- OUTLET PRESSURE
- ATMOSPHERIC PRESSURE

Figure 2. Fisher™ Type T205B Operational Schematic

Table 1. Body Sizes, End Connection Styles and Maximum Allowable Inlet Pressure

BODY SIZE		BODY MATERIAL	END CONNECTION STYLES ⁽¹⁾	MAXIMUM ALLOWABLE INLET PRESSURE	
In.	DN			psig	bar
3/4 or 1	20 or 25	Gray Cast iron	NPT	150	10.3
		WCC Carbon steel	NPT, CL150 RF, CL300 RF or PN 16/25/40 RF	200	13.8
		CF8M/CF3M Stainless steel ⁽²⁾			

1. All flanges are welded. Weld-on flange dimension is 14 in. / 356 mm face-to-face.
2. Pipe nipples and flanges are 316 Stainless steel for flanged body assemblies.

Table 2. Outlet (Control) Pressure Range and Spring Information

OUTLET (CONTROL) PRESSURE RANGE		SPRING COLOR	SPRING WIRE DIAMETER		SPRING FREE LENGTH	
In. w.c.	mbar		In.	mm	In.	mm
1.0 to 2.5 ⁽¹⁾⁽²⁾	2.5 to 6.2 ⁽¹⁾⁽²⁾	Orange	0.072	1.8	3.25	82.6
2.5 to 7.0 ⁽²⁾	6.2 to 17 ⁽²⁾	Red	0.085	2.2	3.63	92.2
7.0 to 16.0	17 to 40	Unpainted	0.105	2.7	3.75	95.2
0.5 to 1.2 psig	34 to 83	Yellow	0.114	2.9	4.31	109
1.2 to 2.5 psig	83 to 172	Green	0.156	4.0	4.06	103
2.5 to 4.5 psig	0.17 to 0.31 bar	Light Blue	0.187	4.8	3.94	100
4.5 to 7 psig	0.31 to 0.48 bar	Black	0.218	5.5	3.98	101

1. Do not use Fluorocarbon (FKM) diaphragm with this spring at diaphragm temperatures lower than 60°F / 16°C.
2. To achieve the published outlet pressure range the spring case must be installed pointing down.

Fisher Type T205B

Tank Blanketing Regulator

Table 3. Available Construction and Trim Materials

AVAILABLE CONSTRUCTION MATERIALS					AVAILABLE TRIM OPTIONS			
Body and Casing	Guide Insert	Diaphragm Head	Lever Assembly and Bias Spring	Stem	Trim Option Code	Diaphragm Material	Disk and O-ring Material	Operating Temperature Ranges
Gray Cast iron, WCC Carbon steel or CF8M/CF3M Stainless steel ⁽¹⁾	316 Stainless steel	304 Stainless steel	302 Stainless steel	Nitronic® 60	Standard	Fluorinated Ethylene Propylene (FEP)	Nitrile (NBR)	-20 to 180°F / -29 to 82°C
					NN	Nitrile (NBR)	Nitrile (NBR)	-40 to 180°F / -40 to 82°C
					VV	Fluorocarbon (FKM)	Fluorocarbon (FKM)	40 to 300°F / 4 to 149°C
					TV	Fluorinated Ethylene Propylene (FEP)	Fluorocarbon (FKM)	40 to 180°F / 4 to 82°C
					TK	Fluorinated Ethylene Propylene (FEP)	Perfluoroelastomer (FFKM)	0 to 180°F / -18 to 82°C
					TE	Fluorinated Ethylene Propylene (FEP)	Ethylene Propylene Diene (EPDM)	-20 to 180°F / -29 to 82°C

1. Pipe nipples and flanges are 316 Stainless steel for flanged body assemblies.

Table 4. Fisher™ Type T205B Flow and Sizing Coefficients

ORIFICE SIZE		REGULATING			WIDE-OPEN		
In.	mm	C _g	C _v	C ₁	C _g	C _v	C ₁
3/8	9.5	98	2.8	34.6	101	2.9	34.6

Table 5. Flow Rate Conversion

MULTIPLY MAXIMUM PUMP RATE IN	BY	TO OBTAIN
U.S. GPM	8.021	SCFH air required ⁽¹⁾
U.S. GPH	0.1337	
Barrels/hour	5.615	
Barrels/day	0.2340	

1. To convert to Nm³/h multiply SCFH by 0.0268.

Table 6. Correction Factors (For Converting Air Flow Rates to Other Gas Flow Rates)⁽¹⁾

BLANKET GAS	SPECIFIC GRAVITY	CORRECTION FACTOR
Natural Gas	0.60	1.291
Nitrogen	0.97	1.015
Dry CO ₂	1.52	0.811

1. For gases of other specific gravities, use equation below.

$$\text{Correction Factor} = \frac{1.00}{\sqrt{SG}}$$

Fisher Type T205B

Tank Blanketing Regulator

Table 7. Flow Rate Required due to Thermal Cooling

VESSEL CAPACITY			AIR FLOW RATE REQUIRED ⁽¹⁾	
Barrels	Gallons	Liters	SCFH	Nm ³ /h
60	2500	9500	60	1.6
100	4200	16,000	100	2.7
500	21,000	79,500	500	13.4
1000	42,000	159,000	1000	26.8
2000	84,000	318,000	2000	53.6
3000	126,000	477,000	3000	80.4
4000	168,000	636,000	4000	107
5000	210,000	795,000	5000	134
10,000	420,000	1,590,000	10,000	268
15,000	630,000	2,385,000	15,000	402
20,000	840,000	3,180,000	20,000	536
25,000	1,050,000	3,975,000	24,000	643
30,000	1,260,000	4,769,000	28,000	750
35,000	1,470,000	5,564,000	31,000	831
40,000	1,680,000	6,359,000	34,000	911
45,000	1,890,000	7,154,000	37,000	992
50,000	2,100,000	7,949,999	40,000	1072
60,000	2,520,000	9,539,000	44,000	1179
70,000	2,940,000	11,129,000	48,000	1286
80,000	3,360,000	12,718,000	52,000	1394
90,000	3,780,000	14,308,000	56,000	1501
100,000	4,200,000	15,898,000	60,000	1608
120,000	5,040,000	19,078,000	68,000	1822
140,000	5,880,000	22,257,000	75,000	2010
160,000	6,720,000	25,347,000	82,000	2198
180,000	7,560,000	28,616,000	90,000	2412

1. Flash point is below 100°F / 38°C or normal boiling point is below 300°F / 149°C.

Fisher Type T205B

Tank Blanketing Regulator

Table 8. Fisher™ Type T205B C_v Coefficient

SPRING RANGE AND COLOR	OUTLET PRESSURE SETTING	OFFSET FROM SETPOINT	INLET PRESSURE		C _v COEFFICIENT	
			psig	bar	3/4 in. / DN 20 Body Size	1 in. / DN 25 Body Size
1.0 to 2.5 in. w.c. / 2.5 to 6.2 mbar Orange	1 in. w.c. / 2.5 mbar	-1 to 2 in. w.c. / -2.5 to 5.0 mbar	1	0.07	1.9	2.7
			2	0.14	2.2	2.7
			6	0.41	2.3	2.8
			10	0.69	2.4	2.8
			20	1.4	2.4	2.7
			60	4.1	2.5	2.6
			100	6.9	1.8	1.6
			150	10.3	1.0	1.2
			200	13.8	0.8	0.8
			200	13.8	0.8	0.8
	2.5 in. w.c. / 6.2 mbar	-1 to 2 in. w.c. / -2.5 to 5.0 mbar	1	0.07	2.1	2.6
			2	0.14	2.3	2.7
			6	0.41	2.5	2.6
			10	0.69	2.5	2.8
			20	1.4	2.5	2.7
			60	4.1	2.5	2.6
			100	6.9	2.5	1.9
			150	10.3	1.0	1.2
			200	13.8	0.8	0.9
			2.5 to 7.0 in. w.c. / 6.2 to 17 mbar Red	2.5 in. w.c. / 6.2 mbar	-1 to 2 in. w.c. / -2.5 to 5.0 mbar	1
2	0.14	1.9				1.8
6	0.41	2.1				1.9
10	0.69	2.1				1.9
20	1.4	2.3				2.0
60	4.1	2.5				2.6
100	6.9	2.5				2.6
150	10.3	1.3				1.3
200	13.8	1.0				0.9
200	13.8	1.0				0.9
4 in. w.c. / 10 mbar	-1 to 2 in. w.c. / -2.5 to 5.0 mbar	1		0.07	1.4	1.6
		2		0.14	1.5	1.5
		6		0.41	1.6	1.6
		10		0.69	1.9	1.6
		20		1.4	2.1	1.8
		60		4.1	2.5	2.6
		100		6.9	2.5	2.6
		150		10.3	1.4	1.4
		200		13.8	1.0	0.9
		200		13.8	1.0	0.9
7 in. w.c. / 17 mbar	-2 to 2 in. w.c. / -5 to 5.0 mbar	1	0.07	2.1	2.1	
		2	0.14	2.2	2.1	
		6	0.41	2.2	2.1	
		10	0.69	2.2	2.2	
		20	1.4	2.2	2.3	
		60	4.1	2.5	2.5	
		100	6.9	2.5	2.6	
		150	10.3	1.7	1.9	
		200	13.8	1.1	1.3	
		200	13.8	1.1	1.3	
7.0 to 16.0 in. w.c. / 17 to 40 mbar Unpainted	11 in. w.c. / 27 mbar	20% droop	1	0.07	1.5	1.9
			2	0.14	1.6	1.6
			6	0.41	1.6	1.7
			10	0.69	1.7	1.7
			20	1.4	1.8	1.7
			60	4.1	2.3	2.2
			100	6.9	2.4	2.4
			150	10.3	2.4	2.4
			200	13.8	1.9	1.9
			200	13.8	1.9	1.9
	15 in. w.c. / 37 mbar	20% droop	2	0.14	1.9	1.9
			6	0.41	1.8	1.9
			10	0.69	1.8	1.9
			20	1.4	2.0	1.9
			60	4.1	2.3	2.3
			100	6.9	2.4	2.5
			150	10.3	2.5	2.4
			200	13.8	2.5	2.5
			200	13.8	2.5	2.5
			200	13.8	2.5	2.5

Fisher Type T205B

Tank Blanketing Regulator

Table 8. Fisher™ Type T205B C_v Coefficient (continued)

SPRING RANGE AND COLOR	OUTLET PRESSURE SETTING	OFFSET FROM SETPOINT	INLET PRESSURE		C _v COEFFICIENT	
			psig	bar	3/4 in. / DN 20 Body Size	1 in. / DN 25 Body Size
0.5 to 1.2 psig / 34 to 83 mbar Yellow	0.5 psig / 34 mbar	20% droop	2	0.14	1.5	1.6
			6	0.41	1.5	1.5
			10	0.69	1.5	1.4
			20	1.4	1.5	1.5
			60	4.1	1.9	1.8
			100	6.9	2.3	2.2
			150	10.3	2.4	2.3
	1.2 psig / 83 mbar	20% droop	2	0.14	2.0	2.2
			6	0.41	2.0	2.0
			10	0.69	1.9	2.0
			20	1.4	2.0	2.0
			60	4.1	2.2	2.2
			100	6.9	2.3	2.3
			150	10.3	2.3	2.0
1.2 psig to 2.5 psig / 83 to 172 mbar Green	1.2 psig / 83 mbar	20% droop	2	0.14	1.4	1.5
			6	0.41	1.2	1.2
			10	0.69	1.2	1.1
			20	1.4	1.2	1.1
			60	4.1	1.1	1.1
			100	6.9	1.2	1.2
			150	10.3	1.4	1.4
	2.5 psig / 172 mbar	20% droop	4	0.28	1.9	1.9
			6	0.41	1.5	1.8
			10	0.69	1.8	1.7
			20	1.4	1.7	1.8
			60	4.1	1.8	1.8
			100	6.9	1.9	1.8
			150	10.3	2.0	1.6
2.5 to 4.5 psig / 0.17 to 0.31 bar Light Blue	2.5 psig / 0.17 bar	20% droop	4	0.28	1.4	1.4
			6	0.41	1.2	1.2
			10	0.69	1.2	1.2
			20	1.4	1.1	1.2
			60	4.1	1.1	1.0
			100	6.9	1.1	1.1
			150	10.3	1.1	1.0
	4.5 psig / 0.31 bar	20% droop	8	0.55	1.7	1.7
			10	0.69	1.5	1.7
			20	1.4	1.6	1.6
			60	4.1	1.7	1.5
			100	6.9	1.7	1.6
			150	10.3	1.7	1.4
			200	13.8	1.7	1.5
4.5 to 7 psig / 0.31 to 0.48 bar Black	4.5 psig / 0.31 bar	20% droop	10	0.69	1.1	1.2
			20	1.4	1.1	1.1
			60	4.1	1.1	1.0
			100	6.9	1.1	1.1
			150	10.3	1.1	0.9
			200	13.8	1.0	1.0
			7 psig / 0.48 bar	20% droop	10	0.69
	20	1.4			1.5	1.5
	60	4.1			1.5	1.5
	100	6.9			1.5	1.5
	150	10.3			1.5	1.3
	200	13.8			1.5	1.3

Fisher Type T205B Tank Blanketing Regulator

Table 9. Fisher™ Type T205B Flow Capacities⁽¹⁾

SPRING RANGE AND COLOR	OUTLET PRESSURE SETTING	OFFSET FROM SETPOINT	INLET PRESSURE		CAPACITIES IN SCFH / Nm ³ /h OF AIR			
					3/4 in. / DN 20 Body Size		1 in. / DN 25 Body Size	
			psig	bar	SCFH	Nm ³ /h	SCFH	Nm ³ /h
1.0 to 2.5 in. w.c. / 2.5 to 6.2 mbar Orange	1 in. w.c. / 2.5 mbar	-1 to 2 in. w.c. / -2.5 to 5.0 mbar	1	0.07	434	11.6	603	16.2
			2	0.14	708	19.0	852	22.8
			6	0.41	1328	35.6	1595	42.7
			10	0.69	1840	49.3	2094	56.1
			20	1.4	2729	73.1	3149	84.4
			60	4.1	6353	170	6748	181
			100	6.9	9801	263	10,473	281
			150	10.3	8852	237	7015	188
	2.5 in. w.c. / 6.2 mbar	-1 to 2 in. w.c. / -2.5 to 5.0 mbar	1	0.07	455	12.2	563	15.1
			2	0.14	711	19.1	838	22.5
			6	0.41	1429	38.3	1485	39.8
			10	0.69	1886	50.5	2086	55.9
			20	1.4	2834	76.0	3081	82.6
			60	4.1	6456	173	6729	180
			100	6.9	10,044	269	10,396	279
			150	10.3	9273	249	8001	214
2.5 to 7.0 in. w.c. / 6.2 to 17 mbar Red	2.5 in. w.c. / 6.2 mbar	-1 to 2 in. w.c. / -2.5 to 5.0 mbar	1	0.07	391	10.5	402	10.8
			2	0.14	594	15.9	580	15.5
			6	0.41	1216	32.6	1058	28.4
			10	0.69	1563	41.9	1463	39.2
			20	1.4	2650	71.0	2340	62.7
			60	4.1	6421	172	6676	179
			100	6.9	10,000	268	10,340	277
			150	10.3	14,498	389	11,300	303
	4 in. w.c. / 10 mbar	-1 to 2 in. w.c. / -2.5 to 5.0 mbar	1	0.07	11,341	304	9858	264
			2	0.14	298	8.0	340	9.1
			6	0.41	470	12.6	472	12.6
			10	0.69	904	24.2	878	23.5
			20	1.4	1396	37.4	1212	32.5
			60	4.1	2416	64.7	2036	54.6
			100	6.9	6388	171	6598	177
			150	10.3	10,032	269	10,222	274
	7 in. w.c. / 17 mbar	-2 to 2 in. w.c. / -5 to 5.0 mbar	150	10.3	14,540	390	14,402	386
			200	13.8	11,877	318	10,424	279
			1	0.07	417	11.2	417	11.2
			2	0.14	673	18.0	626	16.8
6			0.41	1219	32.7	1199	32.1	
10			0.69	1676	44.9	1666	44.6	
20			1.4	2571	68.9	2639	70.7	
60			4.1	6302	169	6535	175	
7.0 to 16.0 in. w.c. / 17 to 40 mbar Unpainted	11 in. w.c. / 27 mbar	20% droop	100	6.9	9897	265	10,225	274
			150	10.3	14,390	386	14,165	380
			200	13.8	13,907	373	19,101	512
			1	0.07	272	7.3	340	9.1
			2	0.14	453	12.1	458	12.3
			6	0.41	879	23.6	920	24.7
			10	0.69	1258	33.7	1266	33.9
			20	1.4	2054	55.0	1938	51.9
	15 in. w.c. / 37 mbar	20% droop	60	4.1	5801	156	5764	154
			100	6.9	9559	256	9636	258
			150	10.3	13,813	370	13,781	369
			200	13.8	18,695	501	18,494	496
			2	0.14	537	14.4	534	14.3
			6	0.41	994	26.6	1028	27.6
			10	0.69	1336	35.8	1391	37.3
			20	1.4	2248	60.2	2205	59.1
60	4.1	5892	158	5865	157			
100	6.9	9562	256	9738	261			
150	10.3	13,895	372	13,352	358			
200	13.8	18,568	498	18,554	497			

1. For blanketing (pad) gases other than air, multiply the given air flow rate by the correction factors in Table 6. For gases of other specific gravities, divide the given air flow rate by the square root of the appropriate specific gravity.

Fisher Type T205B

Tank Blanketing Regulator

Table 9. Fisher™ Type T205B Flow Capacities⁽¹⁾ (continued)

SPRING RANGE AND COLOR	OUTLET PRESSURE SETTING	OFFSET FROM SETPOINT	INLET PRESSURE		CAPACITIES IN SCFH / Nm ³ /h OF AIR			
					3/4 in. / DN 20 Body Size		1 in. / DN 25 Body Size	
			psig	bar	SCFH	Nm ³ /h	SCFH	Nm ³ /h
0.5 to 1.2 psig / 34 to 83 mbar Yellow	0.5 psig / 34 mbar	20% droop	2	0.14	412	11.0	449	12.0
			6	0.41	834	22.4	844	22.6
			10	0.69	1148	30.8	1067	28.6
			20	1.4	1773	47.5	1719	46.1
			60	4.1	5005	134	4731	127
			100	6.9	8906	239	8858	237
			150	10.3	13,636	365	12,946	347
			200	13.8	17,949	481	17,585	471
	1.2 psig / 83 mbar	20% droop	2	0.14	422	11.3	466	12.5
			6	0.41	1030	27.6	1074	28.8
			10	0.69	1388	37.2	1489	39.9
			20	1.4	2321	62.2	2330	62.4
			60	4.1	5536	148	5711	153
			100	6.9	9006	241	9023	242
			150	10.3	13,188	353	11,316	303
			200	13.8	17,694	474	16,532	443
1.2 psig to 2.5 psig / 83 to 172 mbar Green	1.2 psig / 83 mbar	20% droop	2	0.14	296	7.9	313	8.4
			6	0.41	619	16.6	621	16.6
			10	0.69	893	23.9	831	22.3
			20	1.4	1318	35.3	1266	33.9
			60	4.1	2879	77.2	2864	76.8
			100	6.9	4683	126	4843	130
			150	10.3	7699	206	7844	210
			200	13.8	10,650	285	8982	241
	2.5 psig / 172 mbar	20% droop	4	0.28	560	15.0	581	15.6
			6	0.41	698	18.7	834	22.4
			10	0.69	1246	33.4	1192	31.9
			20	1.4	1908	51.1	1996	53.5
			60	4.1	4676	125	4564	122
			100	6.9	7405	199	7209	193
			150	10.3	11,164	299	9333	250
			200	13.8	15,029	403	13,640	366
2.5 to 4.5 psig / 0.17 to 0.31 bar Light Blue	2.5 psig / 0.17 bar	20% droop	4	0.28	407	10.9	418	11.2
			6	0.41	555	14.9	557	14.9
			10	0.69	800	21.4	804	21.5
			20	1.4	1220	32.7	1291	34.6
			60	4.1	2876	77.1	2674	71.7
			100	6.9	4525	121	4319	116
			150	10.3	6237	167	5739	154
			200	13.8	8673	232	7427	199
	4.5 psig / 0.31 bar	20% droop	8	0.55	823	22.1	854	22.9
			10	0.69	949	25.4	1075	28.8
			20	1.4	1723	46.2	1729	46.3
			60	4.1	4252	114	3836	103
			100	6.9	6682	179	6236	167
			150	10.3	9787	262	8032	215
			200	13.8	12,748	342	11,264	302
			10	0.69	706	18.9	741	19.9
4.5 to 7 psig / 0.31 to 0.48 bar Black	4.5 psig / 0.31 bar	20% droop	20	1.4	1161	31.1	1237	33.2
			60	4.1	2776	74.4	2661	71.3
			100	6.9	4265	114	4163	112
			150	10.3	6206	166	5200	139
			200	13.8	7705	207	7620	204
			10	0.69	810	21.7	821	22.0
			20	1.4	1576	42.2	1596	42.8
			60	4.1	3870	104	3734	100
	7 psig / 0.48 bar	20% droop	100	6.9	6001	161	5737	154
			150	10.3	8380	225	7324	196
			200	13.8	11,332	304	9637	258

1. For blanketing (pad) gases other than air, multiply the given air flow rate by the correction factors in Table 6. For gases of other specific gravities, divide the given air flow rate by the square root of the appropriate specific gravity.

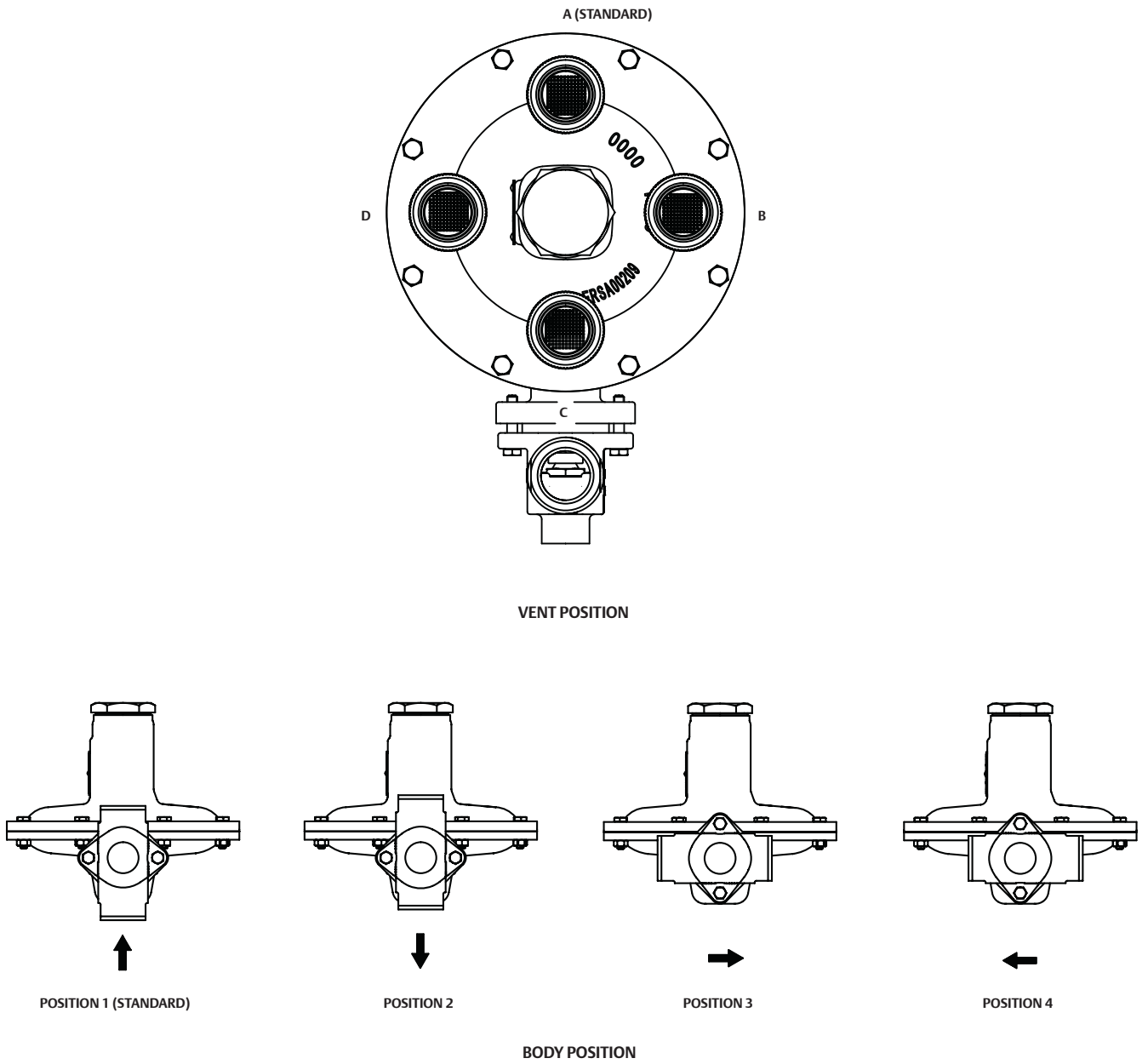

ERSA00746

Figure 3. Body and Vent Position

Fisher Type T205B

Tank Blanketing Regulator

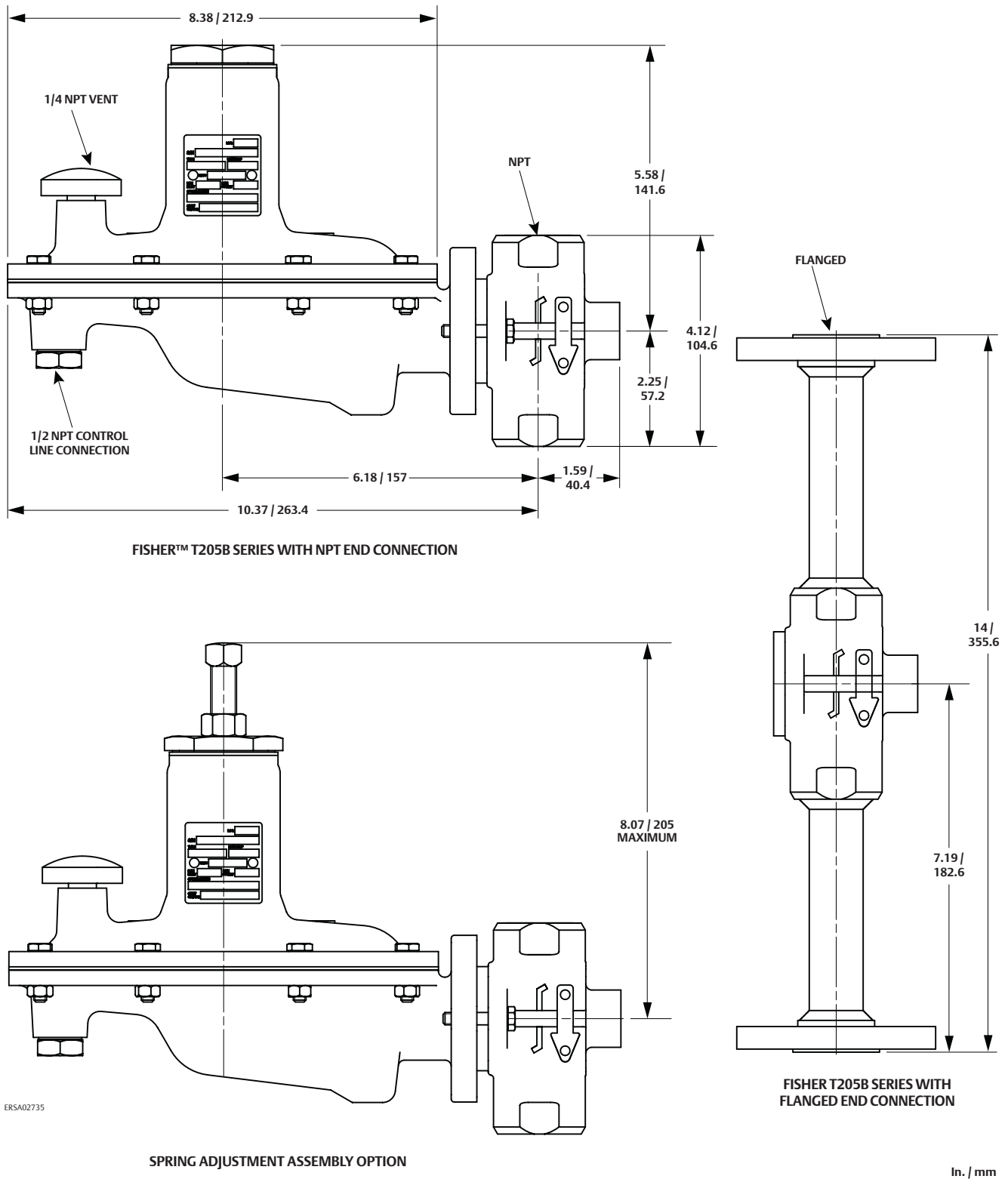

Figure 4. Dimensions

Ordering Guide

Body Size (Select One)

- 3/4 in. / DN 20***
- 1 in. / DN 25***

Body Material and End Connection Style (Select One)

Gray Cast iron

- NPT***

WCC Carbon steel

- NPT***
- CL150 RF***
- CL300 RF***
- PN 16/25/40 RF*** specify rating _____

CF8M/CF3M Stainless steel⁽¹⁾

- NPT***
- CL150 RF***
- CL300 RF***
- PN 16/25/40 RF*** specify rating _____

Outlet (Control) Pressure Range (Select One)

- 1 to 2.5 in. w.c. / 2.5 to 6.2 mbar, Orange***
- 2.5 to 7 in. w.c. / 6.2 to 17 mbar, Red***
- 7 to 16 in. w.c. / 17 to 40 mbar, Unpainted***
- 0.5 to 1.2 psig / 34 to 83 mbar, Yellow***
- 1.2 to 2.5 psig / 83 to 172 mbar, Green***
- 2.5 to 4.5 psig / 0.17 to 0.31 bar, Light Blue***
- 4.5 to 7 psig / 0.31 to 0.48 bar, Black

Trim Material (See Table 3, Select One)

- Standard***
- NN***
- VV***
- TV***
- TK***
- TE***

Adjusting Screw (Select One)

- Internal Flat Circular (**standard**)***
- External Square Head (Available for Green, Light Blue and Black springs only. Steel closing cap is automatically supplied in this option)***

Closing Cap Material (Select One)

- Plastic (**standard**) (not available for Green, Light Blue and Black springs)***
- Steel (**standard** for Green, Light Blue and Black springs)***
- Stainless steel***

Body Position (See Figure 3, Select One)

- Position 1 (**standard**)***
- Position 2***
- Position 3***
- Position 4***

Spring Case Orientation/Vent Type (Select One)

- Spring Case Side (Type Y602-12) (**standard**)***
- Spring Case Down (Type Y602-1)***
- Spring Case Up (Type Y602-11)***

Vent Position (See Figure 3, Select One)

- Position A (**standard**)***
- Position B***
- Position C***
- Position D***

316 Stainless steel Trim Parts (Select One)

- Yes
- No

Replacement Parts Kit (Optional)

- Yes, send one replacement parts kit to match this order.

- continued -

1. Pipe nipples and flanges are 316 Stainless steel for flanged body assemblies.

Fisher Type T205B

Tank Blanketing Regulator

Ordering Guide (continued)

To order this product, complete the Ordering Guide Section or complete the Specification Worksheet and forward to your local Sales Office.

If the construction you need is not offered in the ordering guide section, contact your local Sales Office.

To locate your local Sales Office log on to:
www.fisher.com

Regulators Quick Order Guide	
***	Readily Available for Shipment
**	Allow Additional Time for Shipment
*	Special Order, Constructed from Non-Stocked Parts. Consult your local Sales Office for Availability.
Availability of the product being ordered is determined by the component with the longest shipping time for the requested construction.	

Specification Worksheet
Application
Tank Capacity:
Pump In Rate:
Pump Out Rate:
Blanketing Gas Type:
Blanketing Gas Specific Gravity:
Conservation Vent Setpoint:
Is a vapor recovery regulator required? <input type="checkbox"/> Yes <input type="checkbox"/> No
Pressure
Maximum Inlet Pressure (P_{1max}):
Minimum Inlet Pressure (P_{1min}):
Control Pressure Setting (P_2):
Maximum Flow (Q_{max}):
Performance Required
Accuracy Requirements:
<input type="checkbox"/> 0.25 in. w.c. / 0.6 mbar <input type="checkbox"/> 0.50 in. w.c. / 1 mbar
<input type="checkbox"/> 1 in. w.c. / 2 mbar <input type="checkbox"/> 2 in. w.c. / 5 mbar
<input type="checkbox"/> Others _____
Other Requirements:



The distinctive diamond shape cast into every spring case uniquely identifies the regulator as part of the Fisher™ brand and assures you of the highest-quality engineering, durability, performance and support.

Fisher Type Y692

Tank Blanketing Regulator

Introduction

An Accu-Pressure™ Gas Blanketing Regulator System reduces a high pressure gas, such as nitrogen, to maintain a protective environment above any liquid stored in a tank or vessel when the liquid is being pumped out. Also when the vessel is suddenly cooled, causing vapors inside the vessel to contract, the regulator system replaces the volume of contracting vapors with a volume of blanketing gas to prevent the internal vessel pressure from decreasing. In both cases, a slight positive vessel pressure prevents outside air, moisture and other contaminants from entering the vessel and the possible collapse of the vessel walls.

The Fisher™ Type Y692 is a direct-operated regulator used for accurate pressure control on very low pressure blanketing systems. Downstream pressure is sensed through a pitot tube installed in the lower casing of the regulator for units with internal pressure registration or through a downstream control line for units with external pressure registration. The Type Y692 is available in NPS 1-1/2 and 2 / DN 40 and 50 body sizes.

Body Material, Body Sizes and End Connection Styles⁽¹⁾

Cast iron

NPS 1-1/2 / DN 40: NPT
NPS 2 / DN 50: CL125 FF or NPT

Steel

NPS 1-1/2 and 2 / DN 40 and 50:
NPT, SWE, CL150 RF, CL300 RF or
PN 16/25/40 RF

Stainless steel

NPS 1-1/2 and 2 / DN 40 and 50:
NPT, CL150 RF, CL300 RF or
PN 16/25/40 RF

Maximum Inlet Pressure

150 psig / 10.3 bar

Maximum Outlet (Casing) Pressure

15 psig / 1.0 bar

Maximum Operating Outlet (Control) Pressure to Avoid Internal Part Damage

3 psig / 0.21 bar above outlet (control) pressure setting

Control Pressure Ranges

1 in. w.c. to 10 psig / 2 mbar to 0.69 bar
in seven ranges
See Table 2

Flow Capacities

See Table 3

Pressure Registration

Class VI (Soft Seat)

Pressure Registration

Internal (**standard**) or External

Relief Sizing Coefficients

See Table 4

IEC Sizing Coefficients

XT: 0.775
FD: 0.50
FL: 0.89

Temperature Capabilities

Nitrile (NBR): -20 to 180°F / -29 to 82°C
Fluorocarbon (FKM): 0 to 300°F /
-18 to 149°C
Perfluoroelastomer (FFKM): -20 to
300°F / -29 to 149°C
Ethylenepropylene (EPDM): -20 to
275°F / -29 to 135°C

Approximate Shipping Weights

Cast iron body: 45 lbs / 20 kg
Steel / Stainless steel body:
57 lbs / 26 kg

Canadian Registration Number (CRN)

Approved

PED (Pressure Equipment Directive) Category

The Fisher Type Y692 may be used as a safety accessory with pressure equipment in the PED 97/23/EC Category I.

Additional Technical Data

For more technical information, contact your local Sales Office or log on to:

www.fisher.com



Features

- Ease of Inspection and Maintenance
- Accuracy of Control
- Speed of Response
- Ease of Installation
- NACE Construction Available

1. Fabricated by using slip-on flanges and socket welding nipples into body.

Fisher Type Y692

Tank Blanketing Regulator

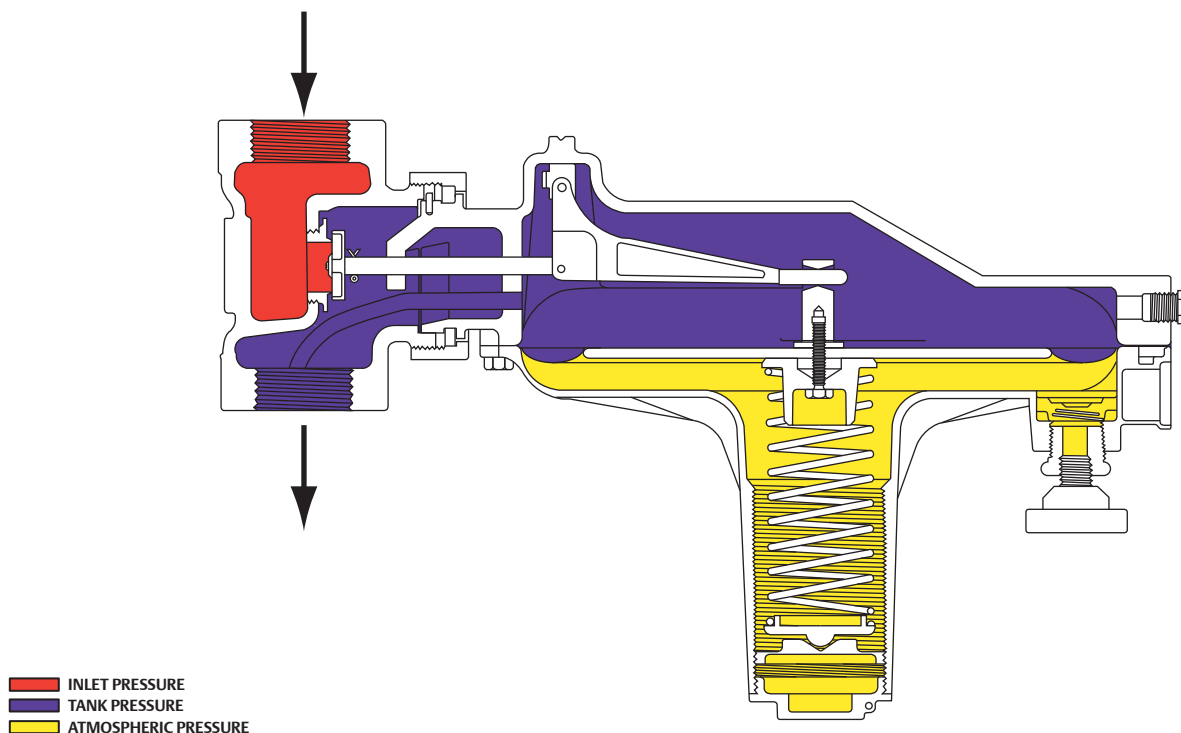

Figure 2. Operational Schematic

Table 1. Construction Materials

BODY, UNION NUT, SPRING CASE AND LOWER CASING ASSEMBLY	CONTROL SPRING, CONTROL SPRING SEAT, SPLIT RING AND DIAPHRAGM PLATE	DIAPHRAGM	ORIFICE, PUSHER POST, PUSHER POST CONNECTOR LEVER ASSEMBLY, STEM AND PITOT TUBE	O-RING	GASKET	DISK ASSEMBLY
Cast iron, WCC Steel or CF8M Stainless steel	Plated steel	Nitrile (NBR) (standard), Fluorocarbon (FKM), Ethylenepropylene (EPDM) and Silicone (VMQ)	Stainless steel	Nitrile (NBR), Fluorocarbon (FKM), Perfluoroelastomer (FFKM), Ethylenepropylene (EPDM)	Composition	Nitrile (NBR) and Stainless steel, Fluorocarbon (FKM) and Stainless steel, Polytetrafluoroethylene (PTFE) and Stainless steel or Ethylenepropylene (EPDM) and Stainless steel

Table 2. Control Pressure Ranges

CONTROL PRESSURE RANGES WITH CASE BARREL POINTED DOWN	SPRING PART NUMBER	SPRING COLOR	SPRING WIRE DIAMETER		SPRING FREE LENGTH	
			In.	mm	In.	mm
Light Spring Assembly ⁽¹⁾	1D892527022	Brown	0.109	2.77	6.12	155
	0B019727052	Iridite	0.148	3.76	6.00	152
	0B019427052	Green	0.187	4.75	6.00	152
	0B019627032	Blue	0.225	5.71	6.00	152
	0A081127202	Orange	0.250	6.35	6.00	152
Heavy spring Assembly	0Y066427022	Silver with Green stripe	0.363	9.22	6.00	152
	1H802427032	Silver	0.406	10.3	6.00	152

1. Install with spring case pointing down to achieve low setpoints in these spring ranges.
2. Do not use Fluorocarbon (FKM) diaphragm with these springs at diaphragm temperature lower than 60°F / 16°C.
3. Installation with spring case pointing up will change outlet (control) pressure range to 3 to 5 in. w.c. / 7 to 12 mbar.
4. Installation with spring case pointing up will change outlet (control) pressure range to 5.75 to 14 in. w.c. / 14 to 35 mbar.
5. Installation with spring case pointing up will change outlet (control) pressure range to 7.5 in. w.c. to 1.3 psig / 19 to 90 mbar.

Fisher Type Y692

Tank Blanketing Regulator

Table 3. Blanketing Regulating Capacities in SCFH / Nm³/h of 0.97 Specific Gravity Nitrogen

BODY SIZE	OUTLET PRESSURE RANGE ⁽¹⁾ , ACCURACY AND SPRING COLOR	OUTLET PRESSURE SETTING	INLET PRESSURE		ORIFICE SIZE, In. / mm											
					1/4 / 6.4		3/8 / 9.5		1/2 / 13		3/4 / 19		1 / 25		1-3/16 / 30	
					psig	bar	SCFH	Nm ³ /h	SCFH	Nm ³ /h	SCFH	Nm ³ /h	SCFH	Nm ³ /h	SCFH	Nm ³ /h
NPS 1-1/2 / DN 40	1 to 3 in. w.c. / 2 to 7 mbar -1 to 2 in. w.c. / -2 to 5 mbar Brown	1 in. w.c. / 2 mbar	2	0.14	360	9.7	970	26.0	1750	46.9	3280	87.9	4750	127	3650	97.8
			5	0.34	680	18.2	1560	41.8	2800	75.0	3880	104	3650	97.8	2840	76.1
			10	0.69	1030	27.6	2350	63.0	4210	113	3880	104	3650	97.8		
			20	1.4	1580	42.3	3620	97.0	4900	131	3700	99.2				
			40	2.8	2500	67.0	3620	97.0	4900	131						
			60	4.1	3410	91.4	3620	97.0								
		80	5.5	4320	116											
		100	6.9	4510	121											
		125	8.6	4510	121											
		150	10.3	4510	121											
		2	0.14	360	9.7	970	26.0	1750	46.9	3280	87.9	4750	127	3650	97.8	
		5	0.34	680	18.2	1560	41.8	2800	75.0	3880	104	3650	97.8	2840	76.1	
	10	0.69	1030	27.6	2350	63.0	4210	113	3880	104	3650	97.8				
	20	1.4	1580	42.3	3620	97.0	4900	131	3700	99.2						
	40	2.8	2500	67.0	3620	97.0	4900	131								
	60	4.1	3410	91.4	3620	97.0										
	80	5.5	4320	116												
	100	6.9	4510	121												
	125	8.6	4510	121												
	150	10.3	4510	121												
	-1 to 2 in. w.c. / -2 to 5 mbar Iridite	7 in. w.c. / 17 mbar	0.5	0.03							950	25.5	1180	31.6	1330	35.6
			1	0.07	330	8.8	630	16.9	870	23.3	1340	35.9	1810	48.5	2290	61.4
			2	0.14	470	12.6	950	25.5	1300	34.8	2260	60.6	3160	84.7	4730	127
			5	0.34	770	20.6	1580	42.3	2520	67.5	6070	163	6100	163	6100	163
13			0.9	1270	34.0	2590	69.4	4900	131	6100	163	6100	163			
25			1.7	1850	49.6	4100	110	6100	163	6100	163					
50		3.4	3040	81.5	6100	163	6100	163								
100		6.9	5370	144	6100	163										
150		10.3	6100	163												
6.5 in. w.c to 1.2 psig / 16 to 83 mbar, Green or 0.7 to 2 psig / 48 mbar to 0.14 bar, Blue		1.5 psig / 0.10 bar	2	0.14			789	21.1	1260	33.8	2050	54.9	2660	71.3	3220	86.3
			6	0.41			1740	46.6	2760	74.0	4730	127	9790	182	7530	202
			14	0.97			3156	84.6	5050	121	9470	254	12,500	335		
	30		2.1			4890	131	8050	216	13,360	358					
	50		3.4			7120	191	11,990	321							
	150		10.3			18,030	483									
1 to 3.2 psig / 69 mbar to 0.22 bar 0.6 psig / 41 mbar Orange	3 psig / 0.21 bar	3	0.21									2450	64.7	2840	76.1	
		7	0.48			1550	41.5	2370	63.5	3950	106	5130	137	6312	169	
		14	0.97			2370	63.5	3700	99.2	7020	188	7470	200			
		30	2.1			4500	121	7380	198	11,680	313					
		50	3.4			7020	188	10,750	288							
		150	10.3			17,250	462									
2 to 5.5 psig / 0.14 to 0.38 bar 0.5 psig / 34 mbar Silver with Green stripe	5 psig / 0.34 bar	10	0.69	590	15.8	950	25.5	1180	31.6	1810	48.5	2200	59.0	2370	63.5	
		15	1.0	789	21.1	1030	27.6	1580	42.3	2370	63.5	2840	76.1	3310	88.7	
		20	1.4	950	25.5	1380	37.0	2200	59.0	2920	78.3	3310	88.7			
		35	2.4	1420	38.1	1970	52.8	2920	78.3	4020	108					
		60	4.1	2210	59.2	2920	78.3	4730	127							
		75	5.2	2760	74.0	3470	93.0	5680	152							
		100	6.9	3550	95.1	5130	137									
		150	10.3													
2 to 5.5 psig / 0.14 to 0.38 bar 1 psig / 69 mbar Silver with Green stripe	5 psig / 0.34 bar	10	0.69	950	25.5	1500	40.2	2050	54.9	3230	86.6	4100	110	4580	123	
		15	1.0	1180	31.6	1890	50.7	2760	74.0	4100	110	5520	148	6310	169	
		20	1.4	1380	37.0	2200	59.0	3790	102	5130	137	6310	169			
		35	2.4	1970	52.8	3310	88.7	5130	137	7730	207					
		60	4.1	3160	84.7	5290	142	7890	211							
		75	5.2	4100	110	6390	171	10,260	275							
		100	6.9	5130	137	8680	233									
		150	10.3													
4 to 10 psig / 0.28 to 0.69 bar 1 psig / 69 mbar Silver	10 psig / 0.69 bar	15	1.0	708	19.0	1023	27.4	1338	35.9	1810	48.5	2518	67.5	2990	80.1	
		20	1.4	944	25.3	1377	36.9	1967	52.7	2597	69.9	3148	84.4	4564	122	
		25	1.7	1102	29.5	1652	44.3	2203	59.0	3148	84.4	4013	108			
		40	2.8	1810	48.5	2203	59.0	2912	78.0	4720	127					
		60	4.1	2361	63.3	3148	84.4	4643	124							
		75	5.2	2754	73.8	3541	94.9	5666	152							
		100	6.9	3541	94.9	5193	139									
		150	10.3													
4 to 10 psig / 0.28 to 0.69 bar 2 psig / 0.14 bar Silver	10 psig / 0.69 bar	15	1.0	1023	27.4	1731	46.4	2518	67.5	3620	97.0	4721	127	6295	169	
		20	1.4	1259	33.7	2125	57.0	3384	90.7	5115	137	6295	169	7869	211	
		25	1.7	1574	42.2	2675	71.7	3777	101	6453	173	7082	190			
		40	2.8	2282	61.2	3934	105	5272	141	8656	232					
		60	4.1	2990	80.1	5351	143	8656	232							
		75	5.2	4013	108	6531	175	10,230	274							
		100	6.9	5115	137	8656	232									
		150	10.3													

Light shaded areas show where indicated droop would be exceeded regardless of capacity.
 Dark shaded areas show where maximum operating inlet pressure for a given orifice size is exceeded.
 1. Spring ranges based on regulator installation with the spring case pointed down.

- continued -



Fisher Type Y692

Tank Blanketing Regulator

Table 3. Blanketing Regulating Capacities in SCFH / Nm³/h of 0.97 Specific Gravity Nitrogen (continued)

BODY SIZE	OUTLET PRESSURE RANGE ⁽¹⁾ , ACCURACY AND SPRING COLOR	OUTLET PRESSURE SETTING	INLET PRESSURE		ORIFICE SIZE, In. / mm											
					1/4 / 6.4		3/8 / 9.5		1/2 / 13		3/4 / 19		1 / 25		1-3/16 / 30	
			psig	bar	SCFH	Nm ³ /h	SCFH	Nm ³ /h	SCFH	Nm ³ /h	SCFH	Nm ³ /h	SCFH	Nm ³ /h	SCFH	Nm ³ /h
NPS 2 / DN 50	1 to 3 in. w.c. / 2 to 7 mbar -1 to 2 in. w.c. / -2 to 5 mbar Brown	1 in. w.c. / 2 mbar	2	0.14	320	8.6	930	24.9	1750	46.9	4000	107	5010	134	5930	159
			5	0.34	680	18.2	1560	41.8	2800	75.0	6050	162	4630	124	4260	114
			10	0.69	1030	27.6	2350	63.0	4210	113	3650	97.8	4060	109		
			20	1.4	1580	42.3	3620	97.0	3450	92.5	3650	97.8				
			40	2.8	2500	67.0	4420	118	3450	92.5						
			60	4.1	3410	91.4	4420	118								
			80	5.5	3650	97.8										
			100	6.9	3650	97.8										
			125	8.6	3650	97.8										
			150	10.3	3650	97.8										
			2	0.14	320	8.6	930	24.9	1750	46.9	4000	107	5010	134	5930	159
			5	0.34	680	18.2	1560	41.8	2800	75.0	6050	162	4630	124	4260	114
			10	0.69	1030	27.6	2350	63.0	4210	113	3650	97.8	4060	109		
			20	1.4	1580	42.3	3620	97.0	3450	92.5	3650	97.8				
			40	2.8	2500	67.0	4420	118	3450	92.5						
	60	4.1	3410	91.4	4420	118										
	80	5.5	3650	97.8												
	100	6.9	3650	97.8												
	125	8.6	3650	97.8												
	150	10.3	3650	97.8												
	3 to 11 in. w.c. / 7 to 27 mbar -1 to 2 in. w.c. / -2 to 5 mbar Iridite	7 in. w.c. / 17 mbar	0.5	0.03							950	25.5	1180	31.6	1330	36.5
			1	0.07	330	8.8	630	16.9	870	23.3	1340	35.9	1810	48.5	2290	61.4
			2	0.14	470	12.6	950	25.5	1300	34.8	2260	60.6	3160	84.7	4730	127
			5	0.34	770	20.6	1580	42.3	2520	67.5	6080	163	7890	211	7890	211
			13	0.90	1270	34.0	2590	69.4	4900	131	7890	211	7890	211		
			25	1.7	1850	49.6	4100	110	7180	192	7890	211				
			50	3.4	3040	81.5	6700	180	7890	211						
			100	6.9	5370	144	7890	211								
150			10.3	7890	211											
6.5 in. w.c to 1.2 psig / 16 to 83 mbar, Green or 0.7 to 2 psig / 48 mbar to 0.14 bar, Blue 0.2 psig / 14 mbar			1 psig / 69 mbar	2	0.14			1030	27.6	1340	35.9	2450	65.7	3230	86.6	3390
	6	0.41				1970	52.8	2840	76.1	5680	152	7730	207	8760	235	
	14	0.97				3390	90.9	5130	137	10,650	285	13,490	362			
	30	2.1				5130	137	8130	218	16,730	448					
	50	3.4				7120	191	11,990	321							
	150	10.3						18,310	491							
1 to 3.2 psig / 69 mbar to 0.22 bar 0.6 psig / 41 mbar Orange	3 psig / 0.21 bar	3	0.21									2550	68.3	3050	81.7	
		7	0.48			1740	46.6	2600	69.7	4730	127	5880	158	7140	191	
		14	0.97			3310	88.7	4180	112	770	206	10,450	280			
		30	2.1			5130	137	7930	213	14,480	388					
		50	3.4			7500	201	11,400	306							
		150	10.3			19,820	531									
2 to 5.5 psig / 0.14 to 0.38 bar 0.5 psig / 34 mbar Silver with Green stripe	5 psig / 0.34 bar	10	0.69	590	15.8	950	25.5	1180	31.6	1810	48.5	2200	59.0	2370	63.5	
		15	1.0	789	21.1	1030	27.6	1580	42.3	2370	63.5	2840	76.1	3310	88.7	
		20	1.4	950	25.5	1380	37.0	2200	59.0	2920	78.3	2920	78.3			
		35	2.4	1420	38.1	1970	52.8	2920	78.3	4020	108					
		60	4.1	2210	59.2	2920	78.3	4730	127							
		75	5.2	2760	74.0	3470	93.0	5680	152							
100	6.9	3550	95.1	5130	137											
2 to 5.5 psig / 0.14 to 0.38 bar 1 psig / 69 mbar Silver with Green stripe	5 psig / 0.34 bar	10	0.69	950	25.5	1500	40.2	2050	54.9	4100	110	4100	110	4580	123	
		15	1.0	1180	31.6	1890	50.7	2760	74.0	5520	148	5520	148	6310	169	
		20	1.4	1380	37.0	2200	59.0	3790	102	6310	169	6310	169			
		35	2.4	1970	52.8	2050	54.9	5130	137							
		60	4.1	3160	84.7	5290	142	7890	207							
		75	5.2	4100	110	6390	171	10,260	275							
100	6.9	5130	137	8680	233											
4 to 10 psig / 0.28 to 0.69 bar 1 psig / 69 mbar Silver	10 psig / 0.69 bar	15	1.0	708	19.0	1023	27.4	1338	35.9	2518	67.5	2518	67.5	2990	80.1	
		20	1.4	944	25.3	1377	36.9	1967	52.7	3148	84.4	3148	84.4	4564	122	
		25	1.7	1102	29.5	1652	44.3	2203	59.0	4013	108	4013	108			
		40	2.8	1810	48.5	2203	59.0	2912	78.0							
		60	4.1	2361	63.3	3148	84.4	4643	124							
		75	5.2	2754	73.8	3541	94.9	5666	152							
100	6.9	3541	94.9	5193	139											
4 to 10 psig / 0.28 to 0.69 bar 2 psig / 0.14 bar Silver	10 psig / 0.69 bar	15	1.0	1023	27.4	1731	46.4	2518	67.5	4721	127	4721	127	6295	169	
		20	1.4	1259	33.7	2125	57.0	3384	90.7	6295	169	6295	169	7869	211	
		25	1.7	1574	42.2	2675	71.7	3777	101	7082	190	7082	190			
		40	2.8	2282	61.2	3934	105	5272	141							
		60	4.1	2990	80.1	5351	143	8656	232							
		75	5.2	4013	108	6531	175	10,230	274							
100	6.9	5115	137	8656	232											

Light shaded areas show where indicated droop would be exceeded regardless of capacity.
 Dark shaded areas show where maximum operating inlet pressure for a given orifice size is exceeded.
 1. Spring ranges based on regulator installation with the spring case pointed down.



Fisher Type Y692

Tank Blanketing Regulator

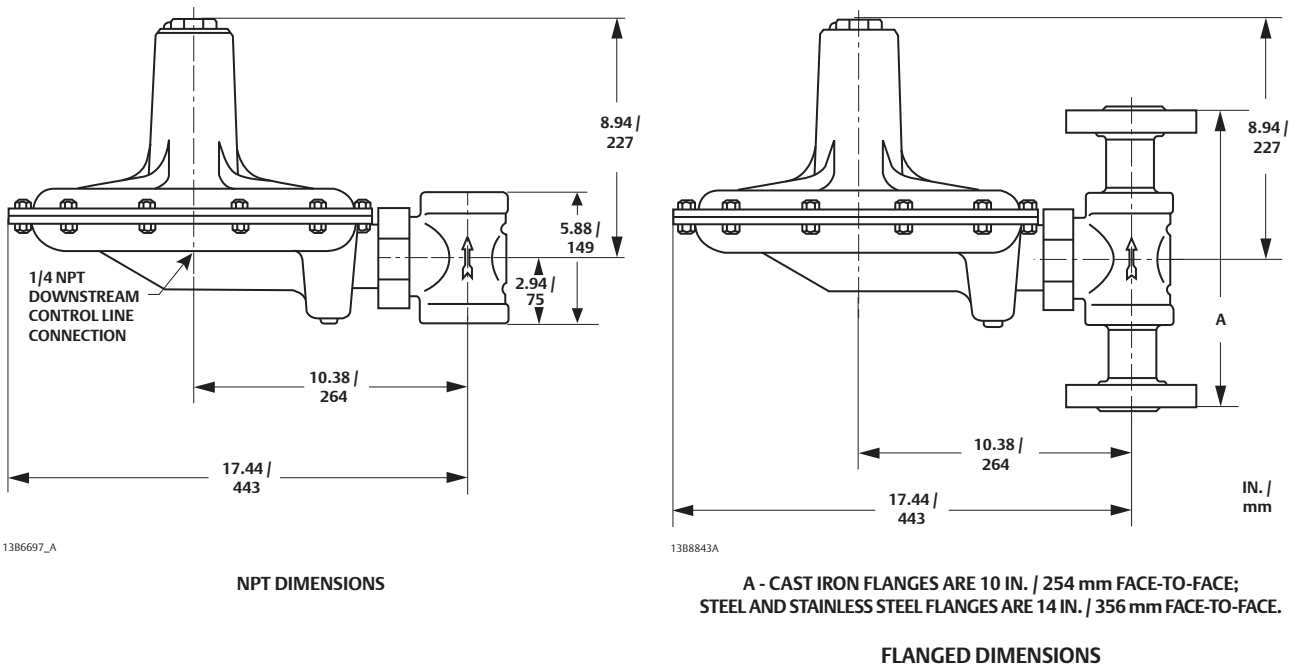

Figure 3. Dimensions

Table 4. Orifice Sizes and Coefficients for Relief Valve Sizing

BODY SIZE		ORIFICE SIZE		WIDE-OPEN C_v	WIDE-OPEN C_g	C_1	K_m
NPS	DN	In.	mm				
1-1/2 and 2	40 and 50	1/4	6.4	1.51	53.0	35	0.79
		3/8	9.5	3.14	111		
		1/2	13	5.43	190		
		3/4	19	11.9	415		
		1	25	20	700		
		1-3/16	30	26	910		

Ordering Guide

Body Size (Select One)

- NPS 1-1/2 / DN 40
- NPS 2 / DN 50

Body Material and End Connection Style (Select One)

Cast Iron

- NPT***
- CL125 FF / (NPS 2 / DN 50 body only)*

WCC Steel

- NPT***
- SWE**
- CL150 RF**
- CL300 RF**
- PN 16/25/40 RF*

CF8M Stainless steel

- NPT***
- CL150 RF**
- CL300 RF**
- PN 16/25/40 RF*

Spring Case Material (Select One)

- Cast iron***
- WCC Steel***
- CF8M Stainless steel**

Diaphragm Case Material (Select One)

- Cast iron***
- WCC Steel***
- CF8M Stainless steel**

Trim Material (Select One)

- 304 Stainless steel***
- 316 Stainless steel**

Diaphragm Material (Select One)

- Nitrile (NBR) (standard)***
- Fluorocarbon (FKM)***
- Ethylenepropylene (EPDM)***
- Silicone (VMQ)***

- continued -

Fisher Type Y692

Tank Blanketing Regulator

Ordering Guide (continued)

Disk Material (Select One)

- Nitrile (NBR) (standard)***
- Fluorocarbon (FKM)***
- Polytetrafluoroethylene (PTFE)***
- Ethylenepropylene (EPDM)***

Orifice Size (Select One)

- 1/4 in. / 6.4 mm***
- 3/8 in. / 9.5 mm***
- 1/2 in. / 13 mm***
- 3/4 in. / 19 mm***
- 1 in. / 25 mm***
- 1-3/16 in. / 30 mm***

Outlet Pressure Range (Select One)

- 1 to 3 in. w.c. / 2 to 7 mbar, Brown***
- 3 to 11 in. w.c. / 7 to 27 mbar, Iridite***
- 6.5 in. w.c. to 1.2 psig / 16 to 83 mbar, Green***
- 0.7 to 2 psig / 48 mbar to 0.14 bar, Blue***
- 1 to 3.2 psig / 69 mbar to 0.22 bar, Orange***
- 2 to 5.5 psig / 0.14 to 0.38 bar, Silver with Green stripe***
- 4 to 10 psig / 0.28 to 0.69 bar, Silver***

Pressure Registration (Select One)

- Internal***
- External**

PTFE Diaphragm Protector (Optional)

- Yes

To order this product, complete the Ordering Guide Section or complete the Specification Worksheet and forward to your local Sales Office.

If the construction you need is not offered in the ordering guide section, contact your local Sales Office.

To locate your local Sales Office log on to:
www.fisher.com

Regulators Quick Order Guide

***	Readily Available for Shipment
**	Allow Additional Time for Shipment
*	Special Order, Constructed from Non-Stocked Parts. Consult your local Sales Office for Availability.
Availability of the product being ordered is determined by the component with the longest shipping time for the requested construction.	

CRN (Canadian Registration Number) Required (Optional)

- Yes

PED (Pressure Equipment Directive) Conformity (Optional)

- Yes

Replacement Parts Kit (Optional)

- Yes, send one replacement parts kit to match this order.

Specification Worksheet

Application

Tank Capacity:

Pump In Rate:

Pump Out Rate:

Blanketing Gas Type:

Blanketing Gas Specific Gravity:

Conservation Vent Setpoint:

Is a vapor recovery regulator required? Yes No

Pressure

Maximum Inlet Pressure (P_{1max}):

Minimum Inlet Pressure (P_{1min}):

Control Pressure Setting (P_2):

Maximum Flow (Q_{max}):

Performance Required

Accuracy Requirements:

- 0.25 in. w.c. / 0.6 mbar
- 0.50 in. w.c. / 1 mbar
- 1 in. w.c. / 2 mbar
- 2 in. w.c. / 5 mbar
- Others _____

Other Requirements:

Fisher Type Y693

Tank Blanketing Regulator

Introduction

An Accu-Pressure™ Gas Blanketing Regulator reduces a high pressure gas, such as nitrogen, to maintain a protective environment above any liquid stored in a vessel or tank when the liquid is being pumped out. Also when the vessel is suddenly cooled, causing vapors inside the vessel to contract, the regulator system replaces the volume of contracting vapors with a volume of blanketing gas to prevent the internal vessel pressure from decreasing. In both cases a slight positive vessel pressure prevents outside air, moisture and other contaminants from entering the vessel and the possible collapse of the vessel walls.

The Fisher™ Type Y693 (Figure 1) is a direct-operated regulator used for accurate pressure control on low pressure blanketing systems. Downstream pressure is sensed through an external control line in the lower casing of the regulator. The Fisher Type Y693 is available in NPS 1-1/2 and 2 / DN 40 and 50 body sizes.

Body Sizes and End Connection Styles

See Table 1

Flow Coefficients

Wide-Open C_g : 185

Wide-Open C_v : 5.6

C1: 33

IEC Sizing Coefficients

X_T : 0.69

F_D : 0.50

F_L : 0.89

Temperature Capabilities

Nitrile (NBR):

-20 to 180°F / -29 to 82°C

Fluorocarbon (FKM):

40 to 300°F / 4 to 149°C

Polytetrafluoroethylene (PTFE):

0 to 300°F / -18 to 149°C

Maximum Inlet Pressure

150 psig / 10.3 bar

Maximum Outlet Pressure

10 psig / 0.69 bar

Maximum Outlet Pressure (Casing)

15 psig / 1.0 bar

Maximum Operating Outlet Pressure to Avoid Internal Part Damage

2 psig / 0.14 bar above outlet pressure setting

Control Pressure Ranges

0.5 in. w.c. to 10 psig /
1.2 mbar to 0.69 bar in 10 ranges
See Table 3

Pressure Registration

External

Spring Case Connection

3/4 NPT female connection

Approximate Weights

Cast iron with Aluminum:

22 lbs / 10 kg

WCC Steel or CF8M Stainless steel:

57 lbs / 26 kg

WCC Steel with Aluminum:

35 lbs / 16 kg

Pressure Registration

External

Additional Technical Data

For more technical information, contact your local Sales Office or log on to:

www.fisher.com



Figure 1. Fisher Type Y693 Tank Blanketing Regulator

Features

- In-Line Inspection and Maintenance
- Accuracy of Control
- Inlet Pressure Sensitivity
- Fast Speed of Response
- High Flow Capacities
- Balanced Trim Design
- 0.5 in. w.c. / 1.2 mbar Setpoint
- Outlet Pressure Stability
- Tight Shutoff Capability

Fisher Type Y693

Tank Blanketing Regulator

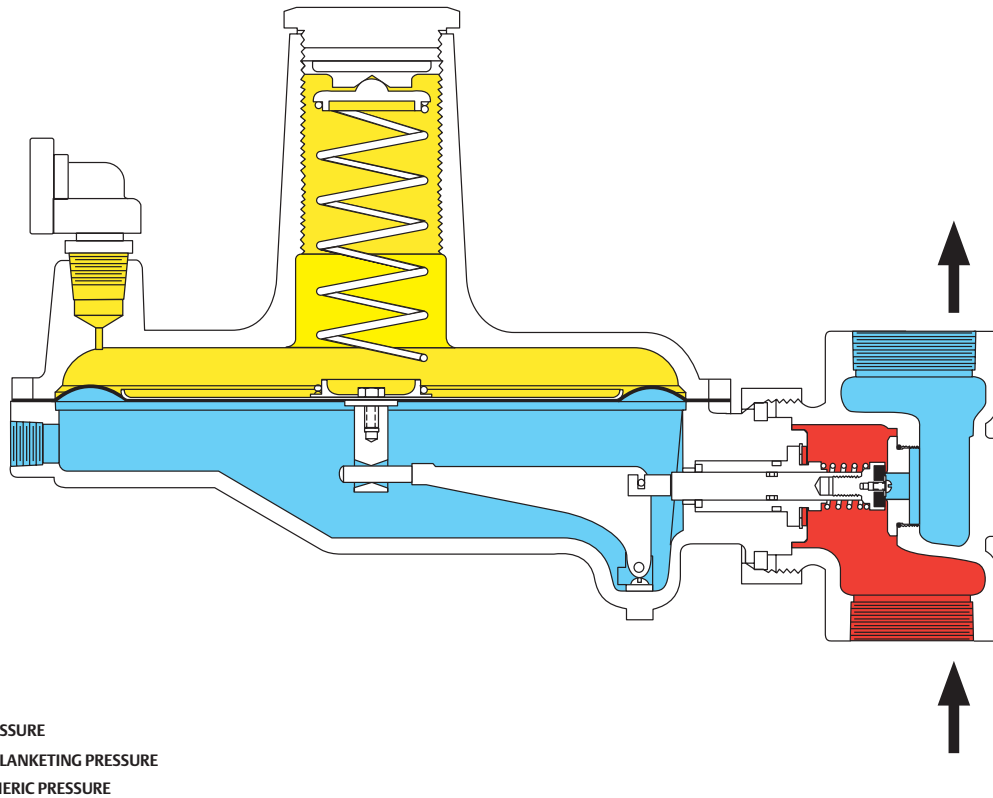

Figure 2. Fisher™ Type Y693 Operational Schematic (Steel or Stainless steel Lower Casing)

Table 1. Body Sizes and End Connection Styles

BODY SIZE, IN. / DN	BODY MATERIAL	
	Cast Iron	Steel or Stainless Steel
1-1/2 / 40	NPT	NPT, CL150 RF, CL300 RF or PN 16/25/40
2 / 50	NPT, CL125 FF	

Table 2. Construction Materials

BODY	SPRING CASE	LOWER DIAPHRAGM CASING	DIAPHRAGM	DISK AND O-RINGS
Steel, CF8M Stainless steel or Cast iron ⁽¹⁾	Aluminum, Steel or CF8M Stainless steel	Aluminum, Steel or CF8M Stainless steel	Nitrile (NBR) or Fluorocarbon (FKM)	Nitrile (NBR) and Stainless steel, Fluorocarbon (FKM) and Stainless steel, PTFE and Stainless steel

1. Cast iron body is only available with aluminum spring case and lower diaphragm casing.

Fisher Type Y693

Tank Blanketing Regulator

Table 3. Control Pressure Ranges

	CONTROL PRESSURE RANGE ⁽¹⁾	COLOR CODE	CONTROL SPRING WIRE DIAMETER, In. / mm	PART NUMBER
Light diaphragm plate	0.5 to 2 in. w.c. / 1.2 to 5 mbar 2 to 5 in. w.c. / 5 to 12 mbar 5 to 8 in. w.c. / 12 to 20 mbar 8 to 18 in. w.c. / 20 to 45 mbar 18 to 32 in. w.c. / 45 to 80 mbar	Brown Red Black White Stripe Green	0.109 / 2.77 0.120 / 3.05 0.130 / 3.30 0.156 / 3.96 0.182 / 4.62	1D892527022 1D892627022 1D892727012 1D893227032 1D893327032
Heavy diaphragm plate	1 to 2 psig / 0.07 to 0.14 bar 1.5 to 3.3 psig / 0.10 to 0.23 bar 2 to 5 psig / 0.14 to 0.34 bar	Blue Orange Yellow	0.225 / 5.72 0.250 / 6.35 0.283 / 7.19	1H975827032 1H975927032 1P615427142
Heavy diaphragm plate with brass closing cap and heavy duty spring adjuster	2 to 5.5 psig / 0.14 to 0.38 bar 4 to 10 psig / 0.28 to 0.69 bar	Green Stripe Red	0.363 / 9.22 0.406 / 10.3	0Y066427022 1H8024000A2

1. Spring ranges are for installations with the spring barrel positioned in any direction. After installation always check/adjust the pressure setting.

Table 4. Capacities

SPRING RANGE, PART NUMBER AND COLOR	CONTROL PRESSURE SETTING, IN. W.C. / mbar	INLET PRESSURE		CAPACITIES IN SCFH / Nm ³ /h OF 0.97 SPECIFIC GRAVITY NITROGEN FOR 1-1/2 AND 2 IN. / DN 40 AND 50 BODIES WITH A 1/2 IN. / 12.7 mm ORIFICE					
				Deviation (From Setpoint)					
				±0.5 in. w.c. / ±1 mbar		-0.5 to 1 in. w.c. / -1 to 2 mbar		-0.5 to 2 in. w.c. / -1 to 5 mbar	
				psig	bar	SCFH	Nm ³ /h	SCFH	Nm ³ /h
0.5 to 2 in. w.c. / 1.2 to 5 mbar 1D892527022 Brown	0.5 / 1 ⁽¹⁾	2	0.14	750	20.1	750	20.1	750	20.1
		5	0.34	1570	42.1	1570	42.1	1570	42.1
		10	0.69	2500	67.0	2500	67.0	2500	67.0
		20	1.4	5000	134	5000	134	5000	134
		40	2.8	8800	236	8800	236	8800	236
		60	4.1	12,100	324	12,100	324	12,100	324
		80	5.5	7100	190	15,400	413	15,400	413
		100	6.9	7100	190	15,200	407	18,600	498
		125	8.6	7100	190	14,200	381	22,700	608
		150	10.3	7100	190	12,200	327	26,700	716
0.5 to 2 in. w.c. / 1.2 to 5 mbar 1D892527022 Brown	1 / 2			±0.5 in. w.c. / ±1 mbar		±1 in. w.c. / ±2 mbar		-1 to 2 in. w.c. / -2 to 5 mbar	
				SCFH	Nm ³ /h	SCFH	Nm ³ /h	SCFH	Nm ³ /h
		2	0.14	750	20.1	1270	34.0	1270	34.0
		5	0.34	1570	42.1	2280	61.1	2280	61.1
		10	0.69	2500	67.0	3400	91.1	3400	91.1
		20	1.4	5000	134	5200	139	5200	139
		40	2.8	8800	236	8800	236	8800	236
		60	4.1	12,100	324	12,100	324	12,100	324
		80	5.5	7100	190	15,400	413	15,400	413
		100	6.9	7100	190	15,200	407	18,600	498
2 to 5 in. w.c. / 5 to 12 mbar 1D892627022 Red	3 / 7	2	0.14	750	20.1	1270	34.0	1270	34.0
		5	0.34	1570	42.1	2280	61.1	2280	61.1
		10	0.69	2500	67.0	3400	91.1	3400	91.1
		20	1.4	5000	134	5200	139	5200	139
		40	2.8	8800	236	8800	236	8800	236
		60	4.1	12,100	324	12,100	324	12,100	324
		80	5.5	11,200	300	15,400	413	15,400	413
		100	6.9	11,200	300	14,200	381	18,600	498
		125	8.6	11,200	300	14,200	381	22,700	608
		150	10.3	11,200	300	14,200	381	26,700	716
5 to 8 in. w.c. / 12 to 20 mbar 1D892727012 Black	7 / 17	2	0.14	710	19.0	1070	28.7	1070	28.7
		5	0.34	1370	36.7	2030	54.4	2030	54.4
		10	0.69	2110	56.5	3130	83.9	3130	83.9
		20	1.4	3050	81.7	4260	114	4260	114
		40	2.8	5580	150	8020	215	8020	215
		60	4.1	10,200	273	11,500	308	11,500	308
		80	5.5	14,200	381	15,400	413	15,400	413
		100	6.9	18,600	498	18,600	498	18,600	498
		125	8.6	11,200	300	22,700	608	22,700	608
		150	10.3	11,200	300	26,700	716	26,700	716

1. For set pressures less than 1 in. w.c. / 2 mbar use only Nitrile (NBR) elastomers.

- continued -



Fisher Type Y693

Tank Blanketing Regulator

Table 4. Capacities (continued)

SPRING RANGE, PART NUMBER AND COLOR	CONTROL PRESSURE SETTING, IN. W.C. / mbar	INLET PRESSURE, PSIG / bar		CAPACITIES IN SCFH / Nm ³ /h OF 0.97 SPECIFIC GRAVITY NITROGEN FOR 1-1/2 AND 2 IN. / DN 40 AND 50 BODIES WITH A 1/2 IN. / 12.7 mm ORIFICE			
				Deviation (From Setpoint)			
				±1 In. w.c. / ±2 mbar		±2 In. w.c. / ±5 mbar	
				SCFH	Nm ³ /h	SCFH	Nm ³ /h
8 to 18 in. w.c. / 20 to 45 mbar 1D893227032 White Stripe	11 / 27	2	0.14	660	17.7	1020	27.3
		5	0.34	1270	34.0	1830	49.0
		10	0.69	2130	57.1	2840	76.1
		20	1.4	3050	81.7	4060	109
		40	2.8	7110	191	7610	204
		60	4.1	9540	256	12,100	324
		80	5.5	13,200	354	15,400	413
		100	6.9	18,600	498	18,600	498
		125	8.6	22,700	608	22,700	608
150	10.3	26,700	716	26,700	716		
18 to 32 in. w.c. / 45 to 80 mbar 1D893227032 Green	20 / 50	2	0.14	590	15.8	710	19.0
		5	0.34	810	21.7	1420	38.1
		10	0.69	1100	29.5	1830	49.0
		20	1.4	1520	40.7	3050	81.7
		40	2.8	2740	73.4	6090	163
		60	4.1	4060	109	10,200	273
		80	5.5	6600	177	15,400	413
		100	6.9	9140	245	18,600	498
		125	8.6	22,700	608	22,700	608
150	10.3	26,700	716	26,700	716		
1 to 2 psig / 69 to 138 mbar 1H975827032 Blue	1 / 2			±0.1 In. w.c. / ±0.007 mbar		±0.2 In. w.c. / ±0.014 mbar	
				SCFH	Nm ³ /h	SCFH	Nm ³ /h
		2	0.14	250	6.70	860	23.0
		5	0.34	1100	29.5	1830	49.0
		10	0.69	1780	47.7	2940	78.8
		20	1.4	2640	70.8	4870	131
		40	2.8	4470	120	8120	218
		60	4.1	6500	174	11,100	297
		80	5.5	9140	245	15,400	413
100	6.9	10,400	279	18,600	498		
1.5 to 3.3 psig / 103 to 228 mbar 1H975827032 Orange	3 / 7			±0.3 In. w.c. / ±0.021 mbar		±0.6 In. w.c. / ±0.041 mbar	
				SCFH	Nm ³ /h	SCFH	Nm ³ /h
		5	0.34	1220	32.7	2200	59.0
		10	0.69	2540	68.1	3050	81.7
		20	1.4	3860	103	5200	139
		40	2.8	7100	190	8880	238
		60	4.1	9340	250	12,100	324
		80	5.5	13,200	354	15,400	413
		100	6.9	15,800	423	18,600	498
2 to 5 psig / 138 mbar to 0.3 bar 1P615427142 Yellow	3 / 7			±0.5 In. w.c. / ±1 mbar		±1 In. w.c. / ±2 mbar	
				SCFH	Nm ³ /h	SCFH	Nm ³ /h
		7	0.48	1400	37.5	2200	59.0
		10	0.69	2330	62.4	3050	81.7
		20	1.4	4060	109	5200	139
		40	2.8	6900	185	8880	238
		60	4.1	9740	261	12,100	324
		80	5.5	12,800	343	15,400	413
		100	6.9	15,200	407	18,600	498
2 to 5.5 psig / 138 mbar to 0.4 bar 0Y066427022 Green Stripe	5 / 12			±0.6 In. w.c. / ±1 mbar		±1 In. w.c. / ±2 mbar	
				SCFH	Nm ³ /h	SCFH	Nm ³ /h
		7	0.48	1200	32.2	1600	42.9
		10	0.69	1420	38.1	2230	59.8
		20	1.4	2440	65.4	3760	101
		40	2.8	4260	114	6290	169
		60	4.1	5890	158	8730	234
		80	5.5	7510	201	11,400	306
		100	6.9	9140	245	14,200	381
4 to 10 psig / 276 mbar to 0.7 bar 1H8024000A2 Red	10 / 25			±0.6 In. w.c. / ±1 mbar		±2 In. w.c. / ±5 mbar	
				SCFH	Nm ³ /h	SCFH	Nm ³ /h
		15	1.0	1600	42.9	2600	69.7
		20	1.4	2030	54.4	3500	93.8
		40	2.8	3650	97.8	6680	179
		60	4.1	5080	136	9300	249
		80	5.5	6500	174	11,900	319
100	6.9	7920	212	14,900	399		

Fisher Type Y693

Tank Blanketing Regulator

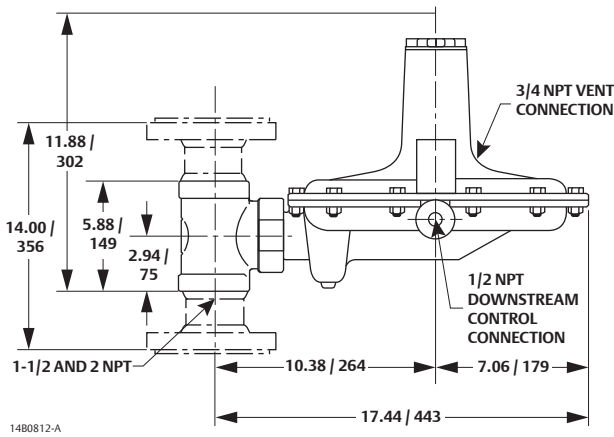

STEEL OR STAINLESS STEEL LOWER CASING VERSION

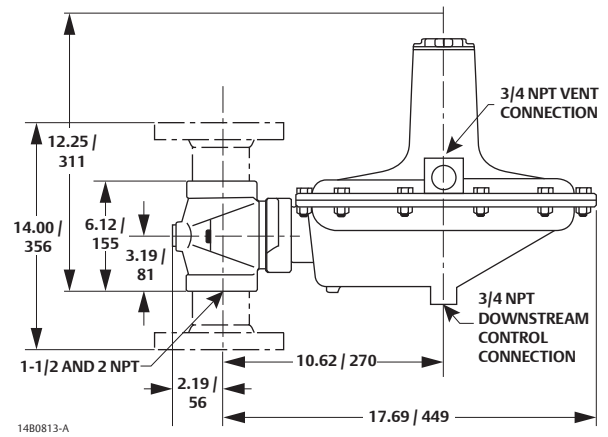

ALUMINUM LOWER CASING VERSION WITH A STEEL BODY

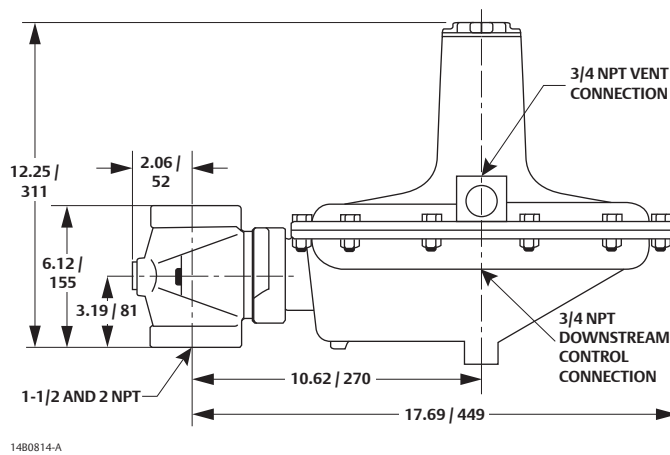

ALUMINUM LOWER CASING VERSION WITH A CAST IRON BODY

IN. / mm

Figure 3. Dimensions

Table 5. Shipping Weights

BODY AND CASING MATERIAL	APPROXIMATE SHIPPING WEIGHT, LBS / kg
WCC Steel or CF8M Stainless steel	57 / 26
WCC Steel with aluminum	35 / 16
Cast iron with aluminum	22 / 10

Fisher Type Y693

Tank Blanketing Regulator

Ordering Guide

Body Size (Select One)

- NPS 1-1/2 / DN 40
- NPS 2 / DN 50

Body Material and End Connection Style (Select One)

Cast Iron

- NPT***
- CL125 FF (NPS 2 / DN 50 body only)*

WCC Steel

- NPT***
- CL150 RF**
- CL300 RF**
- EN PN 16/25/40*

CF8M Stainless steel

- NPT***
- CL150 RF**
- CL300 RF**
- EN PN 16/25/40*

Spring Case (Select One)

- Aluminum (standard with Cast iron bodies)***
- Steel (standard with Steel bodies)***
- CF8M Stainless steel (standard with Stainless steel bodies)**

Lower Diaphragm Casing (Select One)

- Aluminum (standard with Cast iron, not available with Stainless steel bodies)***
- Steel (standard with Steel bodies)***
- CF8M Stainless steel (standard with Stainless steel bodies)**

Diaphragm Material (Select One)

- Nitrile (NBR)***
- Fluorocarbon (FKM)***

PTFE Diaphragm Protector (Optional)

- Yes

Disk and O-rings Material (Select One)

- Nitrile (NBR) and Stainless steel
- Fluorocarbon (FKM) and Stainless steel
- PTFE and Stainless steel

Control Pressure Ranges (Select One)

- 0.5 to 2 in. w.c. / 1.2 to 5 mbar***
- 2 to 5 in. w.c. / 5 to 12 mbar***
- 5 to 8 in. w.c. / 12 to 20 mbar***
- 8 to 18 in. w.c. / 20 to 45 mbar***
- 18 to 32 in. w.c. / 45 to 80 mbar***
- 1 to 2 psig / 0.07 to 0.14 bar***
- 1.5 to 3.3 psig / 0.10 to 0.23 bar***
- 2 to 5 psig / 0.14 to 0.34 bar***
- 2 to 5.5 psig / 0.14 to 0.38 bar***
- 4 to 10 psig / 0.28 to 0.69 bar***

Replacement Parts Kit (Optional)

- Yes, send one replacement parts kit to match this order.

To order this product, complete the Ordering Guide Section or complete the Specification Worksheet and forward to your local Sales Office.

If the construction you need is not offered on this page, contact your local Sales Office.

To locate your local Sales Office log on to:
www.fisher.com

Regulators Quick Order Guide	
***	Readily Available for Shipment
**	Allow Additional Time for Shipment
*	Special Order, Constructed from Non-Stocked Parts. Consult your local Sales Office for Availability.
Availability of the product being ordered is determined by the component with the longest shipping time for the requested construction.	

Specification Worksheet

Application

Tank Capacity:

Pump In Rate:

Pump Out Rate:

Blanketing Gas (Type and Specific Gravity):

Blanketing Gas Specific Gravity:

Boiling and Flash Point of Stored Material:

Is a vapor recovery regulator required? Yes No

Pressure

Maximum Inlet Pressure (P_{1max}):

Minimum Inlet Pressure (P_{1min}):

Control Pressure Setting (P_2):

Maximum Flow (Q_{max}):

Performance Required

Accuracy Requirements:

- 0.25 in. w.c. / 0.6 mbar
- 0.50 in. w.c. / 1 mbar
- 1 in. w.c. / 2 mbar
- 2 in. w.c. / 5 mbar
- Others _____

Other Requirements:

Fisher Type ACE95

Tank Blanketing Regulator

Introduction

The Fisher™ Type ACE95 tank blanketing valve is a pilot-operated valve used for accurate pressure control on low pressure blanketing systems. The unit is stainless steel and actuated by a very large, 76 in.² / 490 cm², diaphragm actuator. Blanketing setpoint is controlled by a single adjusting screw.

The oversized actuator offers high sensitivity to changes in tank pressure, increasing accuracy. A rolling diaphragm is utilized to maintain a fully balanced main valve, ensuring extremely accurate operation under all conditions. Lockup is typically less than 0.3 in. w.c. / 0.7 mbar. The main valve stroke is minimal to further ensure accuracy and fast response.

Body Sizes and End Connection Styles

Angled Body:

3/4 NPT
1 NPT
NPS 1 / DN 25 - CL150 RF
NPS 1 / DN 25 - CL300 RF
NPS 1 / DN 25 - PN 16/25/40 RF
NPS 1 / DN 25 - Sanitary Flange

In-Line Body:

3/4 NPT
1 NPT
NPS 1 / DN 25 - CL150 RF
NPS 1 / DN 25 - CL300 RF
NPS 1 / DN 25 - PN 16/25/40 RF
NPS 1 x 2 / DN 25 x 50 - CL150 RF
NPS 1 x 2 / DN 25 x 50 - PN 16/25/40 RF
NPS 1 / DN 25 - Sanitary Flange

Flow Coefficients and Capacities

See Table 2

IEC Sizing Coefficients⁽¹⁾

X_T : 0.72; F_D : 0.40; F_L : 0.89; K_m : 0.79

Maximum Inlet Pressure

200 psig / 13.8 bar

Minimum Differential Pressure

25 psi / 1.7 bar

Maximum Outlet (Casing) Pressure

20 psig / 1.4 bar

Control Pressure Ranges

-5 in. w.c. to 1.5 psig /
-12 to 103 mbar in six ranges

See Table 3

Pressure Registration

External

Accuracy

Typically within 0.5 in. w.c. / 1 mbar when flowing 5 to 70 percent of advertised capacities in Table 2.

Temperature Capabilities

Nitrile (NBR):

-20 to 180°F / -29 to 82°C

Fluorocarbon (FKM):

0 to 212°F / -18 to 100°C

Ethylenepropylene (EPDM-FDA):

-20 to 212°F / -29 to 100°C

Perfluoroelastomer (FFKM):

-20 to 212°F / -29 to 100°C

Approximate Shipping Weight

40 lbs / 18 kg

Additional Technical Data

For more technical information, contact your local Sales Office or log on to:

www.fisher.com



Figure 1. Fisher Type ACE95 Tank Blanketing Valve

Features

- Stainless steel Construction
- Fully Balanced Pilot Design
- Rolling Diaphragm
- High Sensitivity
- Extremely Accurate Control
- Chemically Compatible Elastomers
- Optional Single Tank Connection
- Diagnostic Port for Servicing

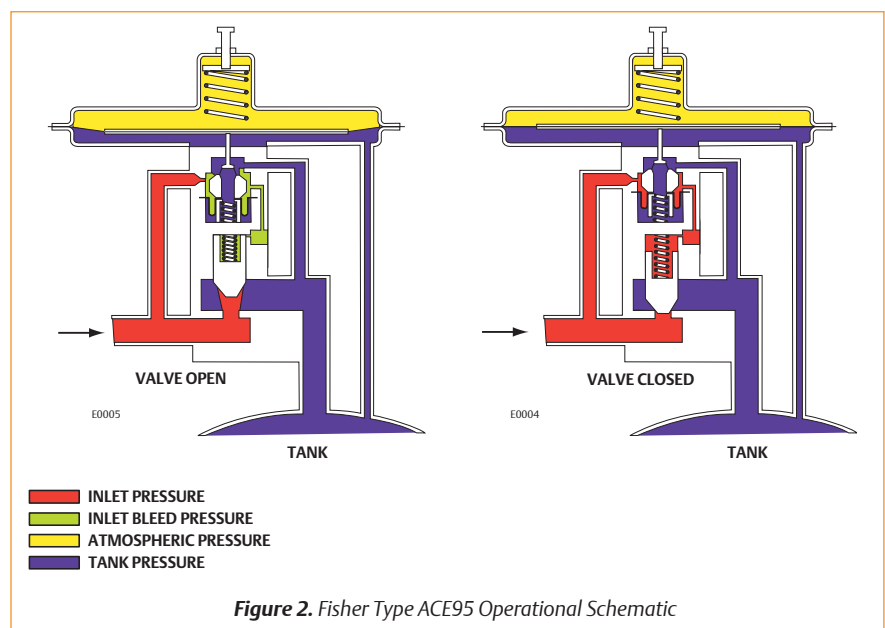
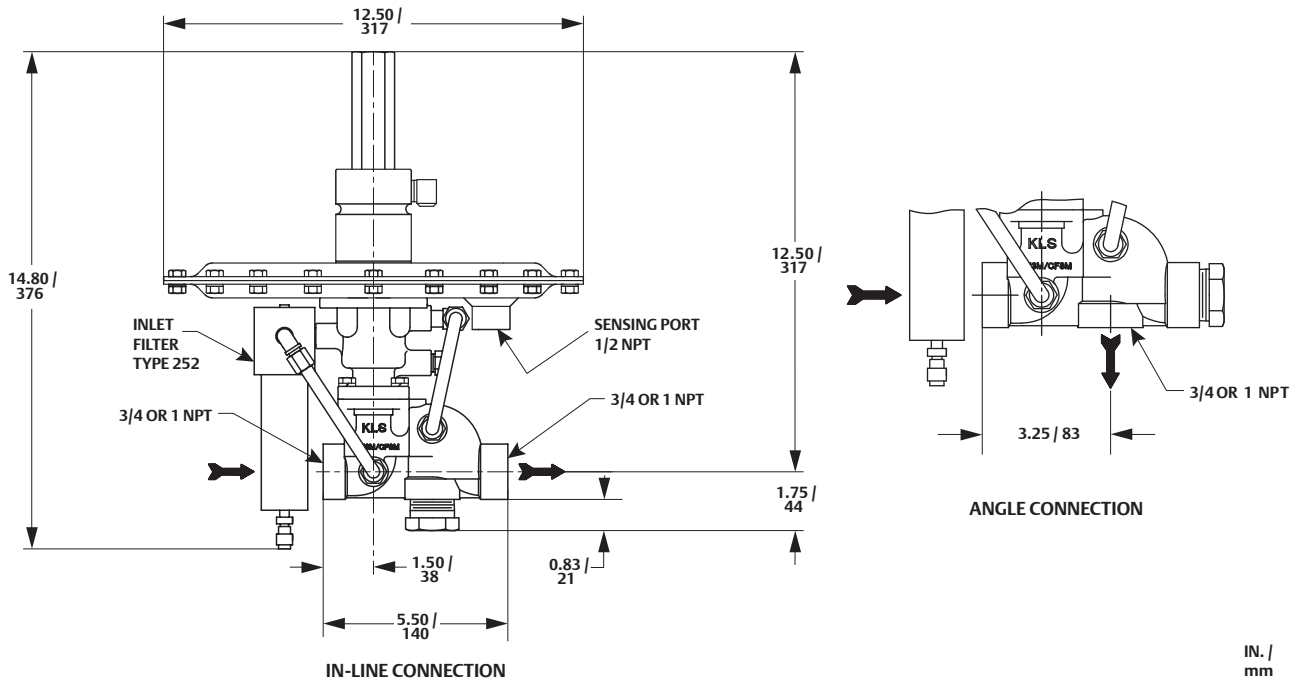

Figure 2. Fisher Type ACE95 Operational Schematic

1. For NPS 1 / DN 25 body size, all trims.

Fisher Type ACE95

Tank Blanketing Regulator



IN. /
mm

CE18680

Figure 3. Dimensions

Table 1. Construction Materials

BODY AND BONNET	TRIM	ELASTOMERS	ACTUATOR DIAPHRAGM	ACTUATOR
CF3M/CF8M Stainless steel	304/316 Stainless steel	Nitrile (NBR), Fluorocarbon (FKM), FDA-Ethylenepropylene (FDA-EPDM) or Perfluoroelastomer (FFKM)	Polytetrafluoroethylene (PTFE)	Carbon steel or 316 Stainless steel

Table 2. Capacities

INLET PRESSURE				CAPACITIES IN SCFH / Nm ³ /h OF NITROGEN									
				C _V = 1		C _V = 2		C _V = 4		C _V = 7.5		C _V = 10	
psig	bar	kg/cm ²	kPa	SCFH	Nm ³ /h	SCFH	Nm ³ /h	SCFH	Nm ³ /h	SCFH	Nm ³ /h	SCFH	Nm ³ /h
25	1.7	1.76	172	1130	30.3	2300	61.6	4440	119	9900	265	11,200	300
30	2.1	2.11	207	1280	34.3	2670	71.6	5020	135	11,200	300	13,000	348
40	2.8	2.81	276	1680	45.0	3440	92.2	6780	182	13,500	362	16,400	440
50	3.5	3.52	345	2050	54.9	4090	110	8140	218	17,800	477	20,200	541
60	4.1	4.22	414	2330	62.4	4800	129	9370	251	18,200	488	22,700	608
70	4.8	4.92	483	2670	71.6	5450	146	10,600	284	23,600	632	26,600	713
80	5.5	5.62	552	3010	80.7	6160	165	12,000	322	27,400	734	30,800	825
90	6.2	6.33	621	3410	91.4	6840	183	13,200	354	30,800	825	34,100	914
100	6.9	7.03	690	3690	98.9	7430	199	14,600	391	34,100	914	38,000	1018
110	7.6	7.73	758	4000	107	8110	217	16,000	429	36,800	986	41,300	1107
120	8.3	8.44	827	4370	117	8750	235	17,200	461	38,800	1040	44,600	1195
130	8.9	9.14	896	4590	123	9340	250	18,300	490	43,400	1163	46,300	1241
140	9.6	9.84	965	4930	132	10,100	271	19,500	523	46,500	1246	50,500	1353
150	10.3	10.55	1034	5300	142	10,800	289	21,000	563	49,900	1337	54,500	1461
160	11.0	11.25	1103	5640	151	11,400	306	21,500	576	53,200	1426	58,200	1560
170	11.7	11.95	1172	5950	159	12,000	322	23,000	616	55,800	1495	62,300	1670
180	12.4	12.65	1241	6320	169	12,600	338	24,700	662	59,600	1597	65,900	1766
190	13.1	13.36	1310	6630	178	13,400	359	25,600	686	62,600	1678	69,600	1865
200	13.8	14.06	1379	6970	187	14,000	375	27,200	729	65,100	1745	71,900	1927

Fisher Type ACE95

Tank Blanketing Regulator

Table 3. Control Pressure Ranges

CONTROL PRESSURE RANGES		SPRING MATERIAL	SPRING FREE LENGTH		SPRING WIRE DIAMETER	
In. w.c.	mbar		In.	mm	In.	mm
-5 to -0.5	-12 to -1	Stainless steel	2.75 0.88 ⁽¹⁾	69.9 22.4 ⁽¹⁾	0.080 0.085 ⁽¹⁾	2.03 2.16 ⁽¹⁾
-1 to 1	-2 to 2	Stainless steel	2.75 1.60 ⁽¹⁾	69.9 40.6 ⁽¹⁾	0.080 0.065 ⁽¹⁾	2.03 1.65 ⁽¹⁾
0.5 to 5 4 to 10 8 to 15 0.5 to 1.5 psig	1 to 12 10 to 25 20 to 37 34 to 103	Stainless steel Stainless steel Stainless steel Stainless steel	2.75 2.00 2.00 2.75	69.9 50.8 50.8 69.9	0.080 0.112 0.125 0.225	2.03 2.84 3.18 5.72

1. The second spring is located under the diaphragm assembly.

Table 4. Main Valve Springs

VALVE C _v	INLET PRESSURE RANGES		SPRING PART NUMBER	SPRING FREE LENGTH		SPRING WIRE DIAMETER	
	psig	bar		In.	mm	In.	mm
1 to 4	25 to 50	1.7 to 3.4	GC220704X22	1.50	38.1	0.038	0.96
	51 to 120	3.5 to 8.3	GC220705X22	1.50	38.1	0.051	1.30
	121 to 200	8.3 to 13.8	GC220706X22	1.50	38.1	0.059	1.50
7.5 to 10	25 to 50	1.7 to 3.4	GC220705X22	1.50	38.1	0.051	1.30
	51 to 120	3.5 to 8.3	GC220706X22	1.50	38.1	0.059	1.50
	121 to 200	8.3 to 13.8	GC220709X22	1.50	38.1	0.072	1.83

Ordering Guide

Body Size and End Connection Style (Select One)

Angled Body

- 3/4 NPT
- 1 NPT
- NPS 1 / DN 25, CL150 RF
- NPS 1 / DN 25, CL300 RF
- NPS 1 / DN 25, PN 16/25/40 RF
- NPS 1 / DN 25, Sanitary Flange

In-Line Body

- 3/4 NPT
- 1 NPT
- NPS 1 / DN 25, CL150 RF
- NPS 1 / DN 25, CL300 RF
- NPS 1 / DN 25, PN 16/25/40 RF
- NPS 1 x 2 / DN 25 x 50, CL150 RF
- NPS 1 x 2 / DN 25 x 50, PN 16/25/40 RF
- NPS 1 / DN 25, Sanitary Flange

Actuator Material (Select One)

- Carbon steel with PTFE diaphragm
- 316 Stainless steel with PTFE diaphragm

Elastomer (Select One)

- Nitrile (NBR)
- Fluorocarbon (FKM)
- Perfluoroelastomer (FFKM)
- Ethylenepropylene (EPDM-FDA)

Inlet Operating Range (Select One)

- 25 to 50 psig / 1.7 to 3.4 bar
- 51 to 120 psig / 3.5 to 8.3 bar
- 121 to 200 psig / 8.3 to 13.8 bar

Control Pressure Ranges (Select One)

- 5 to -0.5 in. w.c. / -12 to -1 mbar
- 1 to 1 in. w.c. / -2 to 2 mbar
- 0.5 to 5 in. w.c. / 1 to 12 mbar
- 4 to 10 in. w.c. / 10 to 25 mbar
- 8 to 15 in. w.c. / 20 to 37 mbar
- 0.5 to 1.5 psig / 34 to 103 mbar

Main Valve Coefficients (Select One)

- C_v - 10 (not available in 3/4 NPT)
- C_v - 7.5 (not available in 3/4 NPT)
- C_v - 4
- C_v - 2
- C_v - 1

- continued -

Fisher Type ACE95

Tank Blanketing Regulator

Ordering Guide (continued)

Options (Select Desired Options)

- Stainless steel Filter (in lieu of standard Aluminum/Zinc)
- Stainless steel Inlet Pressure Gauge
- Control Pressure Gauge, Dwyer®
- Stainless steel Control Gauge for Setpoints Below 2 in. w.c. / 5 mbar
- Stainless steel Control Gauge for Setpoints Above 2 in. w.c. / 5 mbar
- Acrylic Sensing Line Purge
- Stainless steel Sensing Line Purge
- Acrylic Main Line Purge
- Stainless steel Main Line Purge
- Explosion-proof Pressure Switch
- Stainless steel Main Line Check Valve
- Stainless steel Diagnostic and Inlet Gauges

Single Array Manifold (Optional)

- Yes, please add a SAM unit to my order. Please specify tank connection size and style (i.e. NPS 2 / DN 50, CL150 RF). Not available for In-Line bodies

Replacement Parts Kit (Optional)

- Yes, send one replacement parts kit to match this order.

Dwyer® is mark owned by Dwyer, Instruments Inc.

To order this product, complete the Ordering Guide Section or complete the Specification Worksheet and forward to your local Sales Office.

If the construction you need is not offered on this page, contact your local Sales Office.

To locate your local Sales Office log on to: www.fisher.com

Regulators Quick Order Guide	
***	Readily Available for Shipment
**	Allow Additional Time for Shipment
*	Special Order, Constructed from Non-Stocked Parts. Consult your local Sales Office for Availability.
Availability of the product being ordered is determined by the component with the longest shipping time for the requested construction.	

Specification Worksheet

Application	
Tank Capacity:	
Pump In Rate:	
Pump Out Rate:	
Blanketing Gas Type:	
Blanketing Gas Specific Gravity:	
Conservation Vent Setpoint:	
Is a vapor recovery regulator required? <input type="checkbox"/> Yes <input type="checkbox"/> No	
Pressure	
Maximum Inlet Pressure (P_{1max}):	
Minimum Inlet Pressure (P_{1min}):	
Control Pressure Setting (P_2):	
Maximum Flow (Q_{max}):	
Performance Required	
Accuracy Requirements:	
<input type="checkbox"/> 0.25 in. w.c. / 0.6 mbar	<input type="checkbox"/> 0.50 in. w.c. / 1 mbar
<input type="checkbox"/> 1 in. w.c. / 2 mbar	<input type="checkbox"/> 2 in. w.c. / 5 mbar
<input type="checkbox"/> Others _____	
Other Requirements:	

Fisher Type 1190

Tank Blanketing Regulator

Introduction

The Fisher™ Type 1190 is a pilot-operated regulator used for accurate pressure control on low pressure tank blanketing systems.

A Fisher Type 1190 low pressure tank blanketing regulator reduces a high pressure gas, such as nitrogen, to maintain a low pressure protective environment above any liquid stored in a tank or vessel while the liquid is being pumped out. Also, when the vessel cools suddenly, causing the vapor pressure inside the vessel to decrease, the gas blanketing regulator replaces the vapor pressure with a blanketing gas to prevent the internal vessel pressure from decreasing. In both cases, a slight positive vessel pressure prevents outside air, moisture and other contaminants from entering the vessel.

Body Sizes and End Connection Styles

See Table 1

Flow Capacities

See Table 6

Flow Coefficients

See Table 4

IEC Sizing Coefficients

See Table 5

Maximum Operating Inlet Pressure

200 psig / 13.8 bar with cast iron construction or 300 psig / 20.7 bar with a steel or Stainless steel construction

Maximum Outlet (Casing) Pressure

75 psig / 5.2 bar

Maximum Operating Outlet Pressure to Avoid Internal Part Damage

75 psig / 5.2 bar

Differential Pressures

See Table 3

Lower available on request

Control Pressure Ranges

0.25 in. w.c. to 7 psig /
0.6 mbar to 0.48 bar in seven ranges

Pressure Registration

External

Construction Materials

Fisher Type EGR Main Valve

Body and Body Flange: Cast iron, WCC steel (**standard**) or CF8M Stainless steel (optional)

Seat Ring and Valve Plug: 416 Stainless steel (**standard**) or 316 Stainless steel (optional)

Spring: Steel (**standard**) or Inconel® X750 (NACE)

O-rings and Seals: Nitrile (NBR) (**standard**), Fluorocarbon (FKM), Perfluoroelastomer (FFKM) (optional)

Cage: Linear CF8M Stainless steel (**standard**), 416 Stainless steel Whisper Trim™ Cage (optional) or 316 Stainless steel Whisper Trim Cage (NACE)

Fisher Type 1098 Actuator

Lower and Upper Diaphragm Cases: Steel (**standard**) or Stainless steel

Bonnet: Steel (**standard**) or Stainless steel (NACE)

Diaphragm and O-rings: Nitrile (NBR) (**standard**), Fluorocarbon (FKM) or Ethylenepropylene (EPDM) (optional)

Fisher Type T205P Pilot

Body, Spring Case and Diaphragm Casing: Carbon steel (**standard**) or Stainless steel (optional)

Orifice: 303 Stainless steel (standard) or 316 Stainless steel (NACE)

Spring: Steel (**standard**)

Diaphragm: Nitrile (NBR) (**standard**)

O-rings, Gaskets and Seals: Nitrile (NBR) (**standard**), Fluorocarbon (FKM), Perfluoroelastomer (FFKM) or Ethylenepropylene (EPDM) (optional)

Disk: Nitrile (NBR) (**standard**), Fluorocarbon (FKM) or Ethylenepropylene (EPDM) (optional)

Disk Holder: 303 Stainless steel (**standard**) or 316 Stainless steel (NACE)

Fisher Type MR95H Supply Pressure Regulator

Body and Spring Case: Cast iron (**standard**), Carbon steel and Stainless steel (optional)

Orifice: 416 Stainless steel (**standard**) or 316 Stainless steel (NACE)

Valve Plug: 416 Stainless steel with Nitrile (NBR) (**standard**), 416 Stainless steel with Fluorocarbon (FKM) or 316 Stainless steel with Neoprene (CR) (NACE)

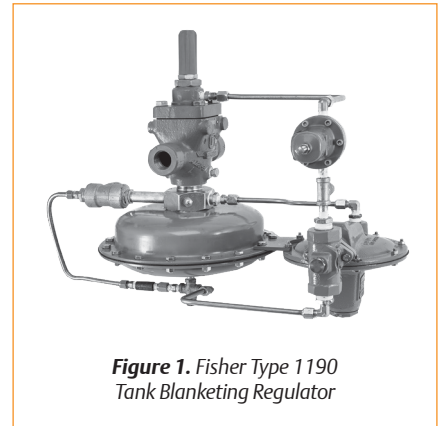

Figure 1. Fisher Type 1190 Tank Blanketing Regulator

Features

- Quick-Change Trim Package
- Easy In-Line Maintenance
- Factory-Piped Pilot Supply
- 0.25 in. w.c. / 0.6 mbar Setpoint
- Whisper Trim™ Cage
- In-Service Travel Inspection
- Optional wireless monitoring capability

Stem Assembly: 416 Stainless steel (**standard**) or 316 Stainless steel (NACE)

Lower Spring Seat: Aluminum

Upper Spring Seat: Steel

Spring: Steel

Diaphragm: Neoprene (CR) (**standard**) or Fluorocarbon (FKM) (optional)

Temperature Capabilities

Nitrile (NBR)

-20 to 180°F / -29 to 82°C

Fluorocarbon (FKM)

40 to 300°F / 4 to 149°C

Ethylenepropylene (EPDM)

-20 to 275°F / -29 to 135°C

Perfluoroelastomer (FFKM)

-20 to 300°F / -29 to 149°C

Approximate Shipping Weight

See Table 7

Additional Technical Data

For more technical information, contact your local Sales Office or log on to:

www.fisher.com

Inconel® is a mark owned by Special Metals Corporation.

Fisher Type 1190

Tank Blanketing Regulator

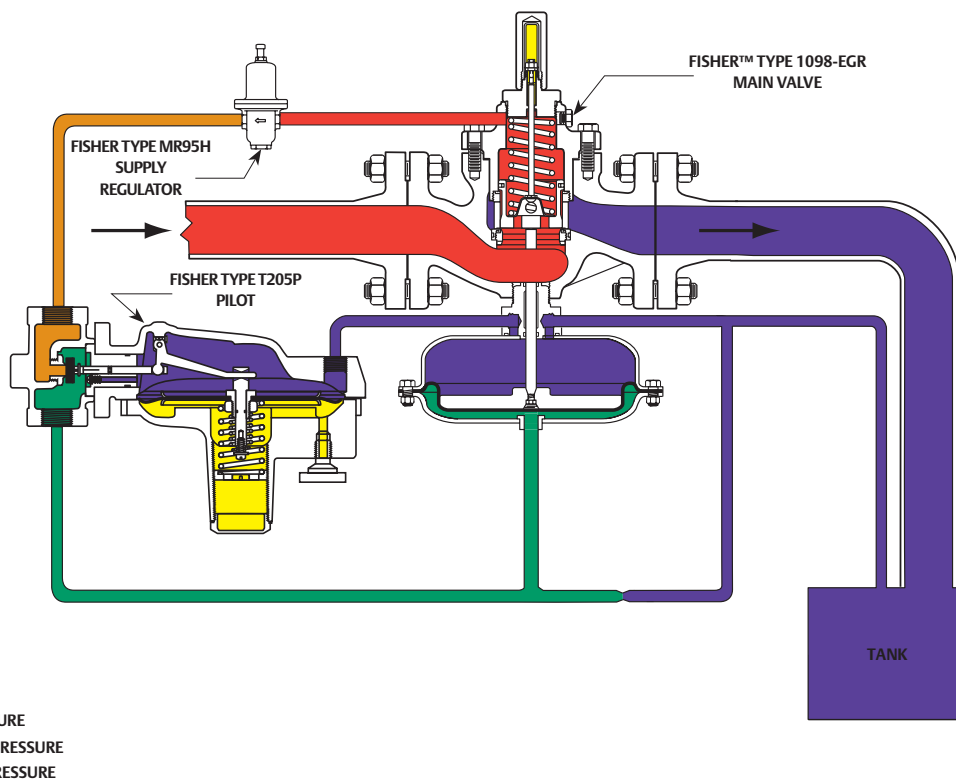

- E0401
- █ INLET PRESSURE
 - █ TANK PRESSURE
 - █ LOADING PRESSURE
 - █ ATMOSPHERIC PRESSURE
 - █ PILOT SUPPLY PRESSURE

Figure 2. Operational Schematic

Table 1. Body Sizes and End Connection Styles

BODY SIZE		BODY MATERIAL	
NPS	DN	Cast Iron	WCC Steel or CF8M Stainless steel
1 and 2	25 and 50	NPT, CL125 FF or CL250 RF flanged	NPT, SWE, BWE, CL150 RF, CL300 RF, CL600 RF or PN 16/25/40 flanged
3, 4 and 6	80, 100 and 150	CL125 FF or CL250 RF flanged	BWE, CL150 RF, CL300 RF, CL600 RF or PN 16 flanged
8 x 6 and 12 x 6	200 x 150 and 300 x 150	----	BWE, CL150 RF, CL300 RF, CL600 RF flanged or PN 25

Table 2. Control Pressure Ranges (Type T205P Pilot)

CONTROL PRESSURE RANGES ⁽¹⁾		SPRING PART NUMBER	SPRING COLOR	SPRING WIRE DIAMETER		SPRING FREE LENGTH	
In. w.c.	mbar			In.	mm	In.	mm
0.25 to 2.5 ⁽²⁾ 2 to 7 ⁽²⁾ 5 to 16	0.6 to 6 ⁽²⁾	1B558527052	Orange	0.072	1.83	3.78	96.0
	5 to 17 ⁽²⁾	1B653827052	Red	0.085	2.16	3.63	92.1
	12 to 40	1B653927022	Unpainted	0.105	2.67	3.75	95.3
0.5 to 1.2 psig 1.1 to 2.5 psig 2.5 to 4.5 psig 4.5 to 7.0 psig	34 to 83	1B537027052	Yellow	0.114	2.90	4.19	106
	76 to 172	1B537127022	Green	0.156	3.96	4.06	103
	172 mbar to 0.31 bar 0.31 to 0.48 bar	1B537227022	Light Blue	0.187	4.75	3.94	100
		1B537327052	Black	0.218	5.54	3.98	101

1. Control pressure ranges based on pilot being installed with the spring case pointed down.
2. Do not use Fluorocarbon (FKM) diaphragm with this spring at diaphragm temperatures lower than 60°F / 16°C.

Inconel® is a mark owned by Special Metals Corporation.



Fisher Type 1190

Tank Blanketing Regulator

Table 3. Maximum and Minimum Differential Pressures for Fisher™ Type EGR Main Valve Spring Selection

BODY SIZE		MAIN VALVE SPRING PART NUMBER	SPRING COLOR	MAXIMUM ALLOWABLE DIFFERENTIAL PRESSURE		MINIMUM DIFFERENTIAL PRESSURE REQUIRED FOR FULL STROKE	
NPS	DN			psid	bar d	psid	bar d
1	25	14A9687X012	Green	60	4.1	2.5	0.17
		14A9680X012	Blue	125	8.6	4	0.28
		14A9679X012	Red	300 or body rating limit, whichever is lower	20.7 or body rating limit, whichever is lower	5	0.34
2	50	14A6626X012	Green	60	4.1	3	0.21
		14A6627X012	Blue	125	8.6	5	0.34
		14A6628X012	Red	300 or body rating limit, whichever is lower	20.7 or body rating limit, whichever is lower	10	0.69
3	80	14A6629X012	Green	60	4.1	4	0.28
		14A6630X012	Blue	125	8.6	6	0.41
		14A6631X012	Red	300 or body rating limit, whichever is lower	20.7 or body rating limit, whichever is lower	11	0.76
4	100	14A6632X012	Green	60	4.1	5	0.34
		14A6633X012	Blue	125	8.6	8	0.55
		14A6634X012	Red	300 or body rating limit, whichever is lower	20.7 or body rating limit, whichever is lower	13	0.90
6, 8 x 6 and 12 x 6	150, 200 x 150 and 300 x 150	14A9686X012	Green	60	4.1	9.5	0.66
		14A9685X012	Blue	125	8.6	14	1.0
		15A2615X012	Red	300 or body rating limit, whichever is lower	20.7 or body rating limit, whichever is lower	19	1.3

Table 4. Flow Coefficients

BODY SIZE		PIPING STYLE										K _m
		Line Size Equals Body Size Piping										
		Standard Linear Cage					Whisper Trim™ Cage					
		C _g		C _v		C ₁	C _g		C _v		C ₁	
NPS	DN	Regulating	Wide-Open	Regulating	Wide-Open		Regulating	Wide-Open	Regulating	Wide-Open		
1	25	600	632	16.8	17.7	35.7	576	607	16.7	17.6	34.5	0.71
2	50	2280	2400	63.3	66.7	36.0	1970	2080	54.7	57.8	36.0	
3	80	4630	4880	132	139	35.1	3760	3960	107	113	35.0	
4	100	7320	7710	202	213	36.2	6280	6610	180	190	34.8	
6	150	12,900	13,600	397	418	32.5	9450	9950	295	310	32.0	
8 x 6	200 x 150	18,480	19,450	578	608	32.0	10,660	11,220	305	321	35.0	
12 x 6	300 x 150	21,180	22,290	662	697	32.0	11,050	11,630	316	332	35.0	
BODY SIZE		2:1 Line Size to Body Size Piping ⁽¹⁾										K _m
		Standard Linear Cage					Whisper Trim Cage					
		C _g		C _v		C ₁	C _g		C _v		C ₁	
NPS	DN	Regulating	Wide-Open	Regulating	Wide-Open		Regulating	Wide-Open	Regulating	Wide-Open		
1	25	568	598	17.2	18.1	33.0	529	557	15.6	16.4	34.0	0.71
2	50	2050	2160	59.6	62.8	34.4	1830	1930	52.3	55.1	35.0	
3	80	4410	4650	128	135	34.4	3630	3830	106	110	34.2	
4	100	6940	7310	198	209	35.0	6020	6340	171	180	35.2	
6	150	12,100	12,800	381	404	31.7	9240	9730	291	306	31.7	
8 x 6	200 x 150	17,370	18,280	543	571	32.0	10,020	10,550	286	301	35.0	
12 x 6	300 x 150	19,900	20,950	622	655	32.0	10,380	10,930	297	312	35.0	

Fisher Type 1190

Tank Blanketing Regulator

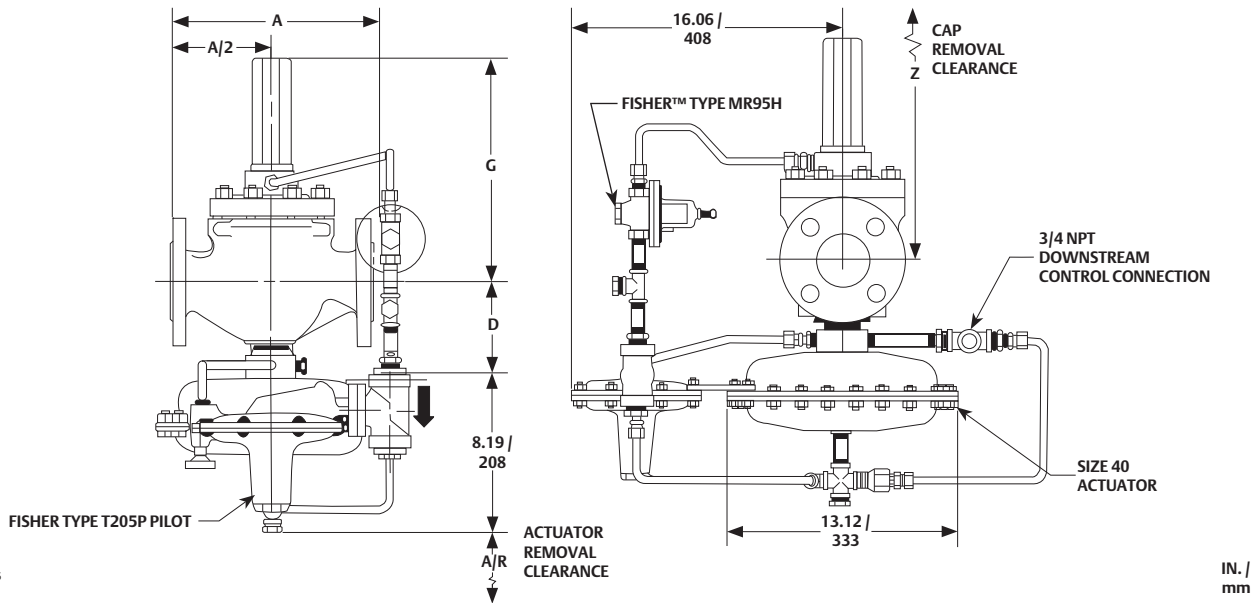

Figure 3. Dimensions

Table 5. IEC Sizing Coefficients

BODY SIZE		X_T	F_D	F_L
NPS	DN			
1	25	0.81	0.43	0.84
2	50	0.82	0.35	
3	80	0.78	0.30	
4	100	0.83	0.28	
6	150	0.67	0.28	
8 x 6 ⁽¹⁾	200 x 150 ⁽¹⁾	0.78	0.33	

1. Standard cage for all sizes.

Table 6. Capacities

INLET PRESSURE		CONTROL PRESSURE		CAPACITIES IN SCFH / Nm ³ /h OF 0.97 SPECIFIC GRAVITY NITROGEN									
psig	bar	psig	bar	NPS 1 / DN 25 Body		NPS 2 / DN 50 Body		NPS 3 / DN 80 Body		NPS 4 / DN 100 Body		NPS 6 / DN 150 Body	
30	2.1	4 or less	0.28 or less	27,300	732	103,900	2785	204,000	5467	322,000	8630	580,000	15,544
40	2.8	7 or less	0.48 or less	33,300	892	126,600	3393	257,000	6888	406,300	10,889	716,100	19,191
50	3.4			39,400	1056	149,800	4015	304,000	8147	480,600	12,880	847,100	22,702
60	4.1			45,500	1219	173,000	4636	351,000	9407	554,900	14,871	978,000	26,210
70	4.8			51,600	1383	196,000	5253	398,000	10,666	629,200	16,863	1,108,900	29,719
80	5.5			57,700	1546	220,000	5896	444,900	11,923	703,500	18,854	1,239,900	33,229
90	6.2	64,000	1715	243,000	6512	491,900	13,183	777,800	20,845	1,370,800	36,737		
100	6.9	7 or less	0.48 or less	70,100	1879	266,000	7129	538,900	14,443	852,100	22,836	1,501,700	40,246
120	8.3			82,300	2206	312,000	8362	632,900	16,962	1,000,600	26,816	1,763,600	47,264
140	9.7			94,500	2533	359,000	9621	726,900	19,481	1,149,200	30,799	2,025,400	54,281
160	11.0			107,000	2868	406,000	10,881	820,900	22,000	1,297,800	34,781	2,287,347	61,301
180	12.4			119,000	3189	452,000	12,114	914,800	24,517	1,446,400	38,764	2,549,200	68,319
200	13.8			131,000	3511	490,000	13,132	1,008,800	27,036	1,595,000	42,746	2,811,000	75,335

Table 7. Dimensions and Shipping Weights

MAIN VALVE BODY SIZE		DIMENSIONS															APPROXIMATE SHIPPING WEIGHT		
		A								D	G	Z	A/R						
		NPT		CL125 FF CAST IRON OR CL150 RF STEEL OR STAINLESS STEEL		CL250 FF CAST IRON OR CL300 RF STEEL OR STAINLESS STEEL		CL600 RF STEEL/ STAINLESS STEEL											
NPS	DN	In.	mm	In.	mm	In.	mm	In.	mm	In.	mm	In.	mm	In.	mm	lbs	kg		
1	25	8.25	210	7.25	184	7.75	197	8.25	210	3.88	98.6	8.62	219	11.38	289	3.00	76.2	85	39
2	50	11.25	286	10.00	254	10.50	267	11.25	286	4.56	116	9.12	232	12.62	321	3.12	79.2	100	45
3	80	----	----	11.75	298	12.50	317	13.25	337	5.31	135	11.25	286	16.25	413	3.88	98.6	145	66
4	100	----	----	13.88	353	14.50	368	15.50	394	6.50	165	12.62	321	18.88	480	5.12	130	195	88
6	150	----	----	17.75	451	18.62	473	20.00	508	7.25	184	13.69	348	20.00	508	6.38	162	380	172

Ordering Guide

Construction (Select One)

Standard

NACE

Fisher™ Type EGR Main Valve

Main Valve Body Size (Select One)

NPS 1 / DN 25*** NPS 6 / DN 150**

NPS 2 / DN 50*** NPS 8 x 6 / DN 200 x 150*

NPS 3 / DN 80*** NPS 12 x 6 / DN 300 x 150*

NPS 4 / DN 100***

Main Valve Body Material (Select One)

Cast iron***

WCC Steel***

CF8M Stainless steel (NACE)***

Main Valve End Connection Style (Select One)

Cast Iron Body

NPT (Only available for 1 or 2 NPT body size)***

CL125 FF***

CL250 RF***

WCC Steel, CF8M Stainless steel

NPT (Only available for 1 or 2 NPT body size)***

SWE*

CL150 RF***

CL300 RF***

CL600 RF***

BWE 40**

BWE 80*

PN 16/25/40** _____ please specify rating

Main Valve Body Flange Material (Select One)

Cast iron***

WCC Steel***

CF8M Stainless steel (NACE)**

Travel Stop (Select One)

100 percent (standard)***

60 percent**

30 percent**

Main Valve Cage Type and Material (Select One)

Linear, CF8M Stainless steel (NACE)***

Whisper Trim™ Cage, 416 Stainless steel***

Whisper Trim Cage, 316 Stainless steel (NACE)***

Main Valve Spring Range (Select One)

60 psig / 4.1 bar maximum drop, Green**

125 psig / 8.6 bar maximum drop, Blue***

400 psig / 27.6 bar maximum drop, Red***

Main Valve Spring Material (Select One)

Steel***

Inconel® X750 (NACE)***

Fisher Type EGR Main Valve (continued)

O-ring and Seal Material (Select One)

Nitrile (NBR)***

Fluorocarbon (FKM)***

Perfluoroelastomer (FFKM)***

Ethylenepropylene (EPDM)**

Fisher Type T205P Pilot

Body Material (Select One)

Carbon steel***

Stainless steel (NACE)***

Spring Case Material (Select One)

Carbon steel***

Stainless steel (NACE)***

Control Pressure Ranges (Select One)

0.25 to 2.5 in. w.c. / 0.6 to 6 mbar***

2 to 7 in. w.c. / 5 to 17 mbar***

5 to 16 in. w.c. / 12 to 40 mbar***

0.5 to 1.2 psig / 34 to 83 mbar***

1.1 to 2.5 psig / 76 to 172 mbar***

2.5 to 4.5 psig / 172 mbar to 0.31 bar***

4.5 to 7 psig / 0.31 to 0.48 bar***

Diaphragm Material (Select One)

Nitrile (NBR)***

Fluorocarbon (FKM)**

O-ring and Seal Material (Select One)

Nitrile (NBR)*** Ethylenepropylene (EPDM)**

Fluorocarbon (FKM)** Perfluoroelastomer (FFKM)*

Closing Cap Material (Select One)

Plastic*** Steel**

Stainless steel**

NACE Required (Select for NACE)

Yes***

Fisher Type 1098 Actuator

Lower Diaphragm Case Material (Select One)

Steel***

Stainless steel (NACE)**

Bonnet Material (Select One)

Steel***

Stainless steel (NACE)**

O-ring Material (Select One)

Nitrile (NBR)***

Fluorocarbon (FKM)***

Ethylenepropylene (EPDM)**

- continued -

Inconel® is a mark owned by Special Metals Corporation.

Fisher Type 1190

Tank Blanketing Regulator

Ordering Guide (continued)

Fisher™ Type 1098 Actuator (continued)

Diaphragm Material (Select One)

- Nitrile (NBR)***
- Fluorocarbon (FKM)***
- Ethylenepropylene (EPDM)**

Fisher Type MR95H Supply Pressure Regulator

Body Material (Select One)

- Cast iron***
- Carbon steel***
- Stainless steel (NACE)***

Spring Case Material (Select One)

- Cast iron***
- Carbon steel***
- Stainless steel***

Valve Plug Material (Select One)

- 416 Stainless steel with Nitrile (NBR)***
- 416 Stainless steel with Fluorocarbon (FKM)***
- 316 Stainless steel with Neoprene (CR) (NACE)**

Fisher Type MR95H Supply Pressure Regulator (continued)

Outlet Pressure Range

- 5 to 30 psig / 0.34 to 2.1 bar, Yellow***

Diaphragm Material (Select One)

- Neoprene (CR)***
- Fluorocarbon (FKM)***

Replacement Parts Kit (Optional)

- Yes, send one replacement parts kit to match this order for each unit.

Quick-Change Trim Package (Optional)

- Yes, send one main valve Quick-Change Trim Package to match this order.

Wireless Position Monitor Mounting Kit (Optional)

- Yes, send one mounting kit for mounting the Topworx™ 4310 or the Fisher 4320 wireless position monitor.

To order this product, complete the Ordering Guide Section or complete the Specification Worksheet and forward to your local Sales Office.

If the construction you need is not offered in the ordering guide section, contact your local Sales Office.

To locate your local Sales Office log on to: www.fisher.com

Regulators Quick Order Guide	
***	Readily Available for Shipment
**	Allow Additional Time for Shipment
*	Special Order, Constructed from Non-Stocked Parts. Consult your local Sales Office for Availability.
Availability of the product being ordered is determined by the component with the longest shipping time for the requested construction.	

Specification Worksheet
Application
Tank Capacity:
Pump In Rate:
Pump Out Rate:
Blanketing Gas Type:
Blanketing Gas Specific Gravity:
Conservation Vent Setpoint:
Is a vapor recovery regulator required? <input type="checkbox"/> Yes <input type="checkbox"/> No
Pressure
Maximum Inlet Pressure (P_{1max}):
Minimum Inlet Pressure (P_{1min}):
Control Pressure Setting (P_2):
Maximum Flow (Q_{max}):
Performance Required
Accuracy Requirements?
Other Requirements:

Fisher T208 Series

Vapor Recovery Regulator

Introduction

The Fisher™ T208 Series are direct-operated tank blanketing vapor recovery regulators. These regulators are used to sense an increase in vessel pressure and vent excessive internal tank pressure to an appropriate vapor recovery disposal or reclamation system. T208 Series may also be used as backpressure regulators or relief valves.

Available Configurations

Fisher Type T208: Tank Blanketing Vapor Recovery regulator with control pressure range of 2 in. w.c. to 7 psig / 5 mbar to 0.48 bar in six different spring ranges and has internal pressure registration requiring no control line.

Fisher Type T208M: Similar to Fisher Type T208 but has a blocked throat and a control line connection for external pressure registration.

Body Sizes and End Connection Styles

See Table 1

Maximum Allowable Inlet (Casing) Pressure

See Table 1

Maximum Outlet Pressure

35 psig / 2.4 bar

Maximum Emergency Inlet Pressure to Avoid Internal Parts Damage

With Nitrile (NBR) or Fluorocarbon (FKM) diaphragm:

35 psig / 2.4 bar

With Fluorinated Ethylene Propylene (FEP) diaphragm:

10 psig / 0.69 bar

Control Pressure Ranges

See Table 3

Flow and Sizing Coefficients

See Table 4

C_v Coefficients and Flow Capacities

See Table 5

Orifice Size

7/16 in. / 11 mm

Body and Casing Materials

Gray cast iron, WCC Carbon steel and CF8M/CF3M Stainless steel

Trim Materials

See Table 2

Material Temperature Capabilities

Elastomer Parts

Nitrile (NBR)

-40 to 180°F / -40 to 82°C

Fluorinated Ethylene Propylene (FEP)

-20 to 180°F / -29 to 82°C

Fluorocarbon (FKM)

40 to 300°F / 4 to 149°C

Ethylene Propylene Diene (EPDM)

-20 to 225°F / -29 to 107°C

Perfluoroelastomer (FFKM)

0 to 300°F / -18 to 149°C

Body Materials

Gray Cast Iron

-20 to 300°F / -29 to 149°C

WCC Carbon steel

-20 to 300°F / -29 to 149°C

CF8M/CF3M Stainless steel

-40 to 300°F / -40 to 149°C

Spring Case Vent Connection

1/4 NPT

Diaphragm Case Control Line Connection (Fisher Type T208M)

1/2 NPT

Approximate Weight

17.7 lbs / 8 kg

Additional Technical Data

For more technical information, contact your local Sales Office or log on to:

www.fisher.com



Figure 1. Fisher Type T208 Tank Blanketing Vapor Recovery Regulator

Features

- Accurate Control
- Easy Conversion
- Rugged Construction
- Simplicity
- Sour Gas Service Capability

Fisher T208 Series

Vapor Recovery Regulator

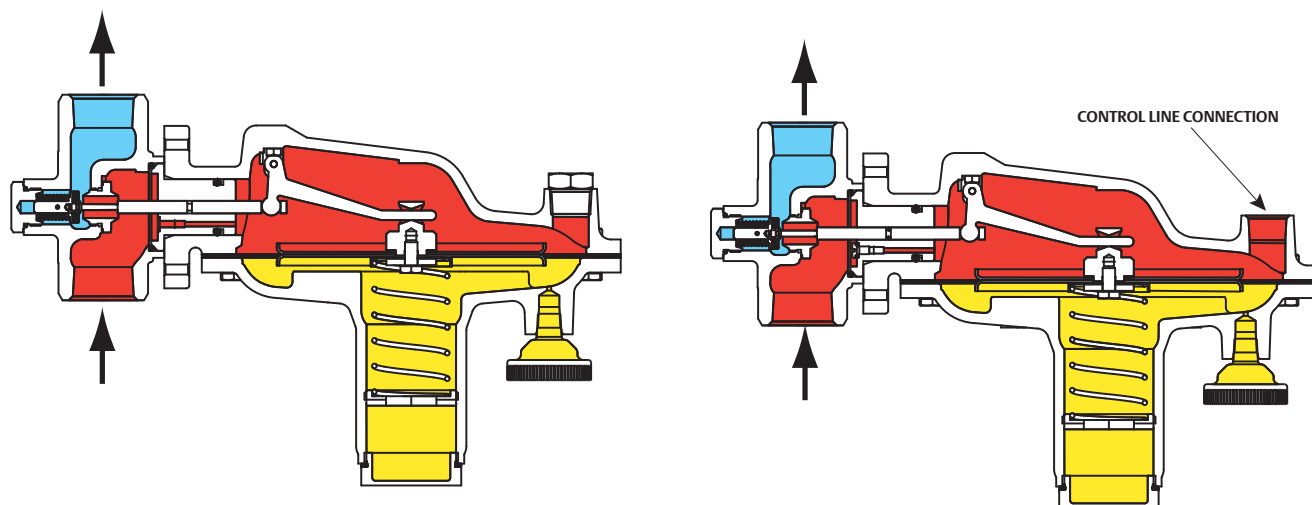

TYPE T208 WITH INTERNAL PRESSURE REGISTRATION

TYPE T208M WITH EXTERNAL PRESSURE REGISTRATION

- INLET PRESSURE
- OUTLET PRESSURE
- ATMOSPHERIC PRESSURE

Figure 2. T208 Series Operational Schematics

Table 1. Body Sizes, End Connection Styles and Maximum Allowable Inlet (Casing) Pressures

BODY SIZE		BODY MATERIAL	END CONNECTION STYLES ⁽¹⁾	MAXIMUM ALLOWABLE INLET (CASING) PRESSURE	
In.	DN			psig	bar
3/4 or 1	20 or 25	Gray cast iron	NPT	35	2.4
		WCC Carbon steel	NPT, CL150 RF, CL300 RF or PN 16/25/40 RF	75	5.2
		CF8M/CF3M Stainless steel ⁽²⁾			

1. All flanges are welded. Weld-on flange dimension is 14 in. / 356 mm face-to-face.
2. Pipe nipples and flanges are 316 Stainless steel for flanged body assemblies.

Table 2. Available Construction and Trim Materials

AVAILABLE CONSTRUCTION MATERIALS				AVAILABLE TRIM OPTIONS			
Body and Casing	Guide Insert, Stem and Pusher Post	Diaphragm Head	Lever Assembly	Trim Option Code	Diaphragm Material	Disk and O-ring Material	Operating Temperature Ranges
Gray cast iron, WCC Carbon steel or CF8M/CF3M Stainless steel ⁽¹⁾	316 Stainless steel	304 Stainless steel	302 Stainless steel	Standard	Nitrile (NBR)	Nitrile (NBR)	-40 to 180°F / -40 to 82°C
				VV	Fluorocarbon (FKM)	Fluorocarbon (FKM)	40 to 300°F / 4 to 149°C
				TV	Fluorinated Ethylene Propylene (FEP)	Fluorocarbon (FKM)	40 to 180°F / 4 to 82°C
				TN	Fluorinated Ethylene Propylene (FEP)	Nitrile (NBR)	-20 to 180°F / -29 to 82°C
				TK	Fluorinated Ethylene Propylene (FEP)	Perfluoroelastomer (FFKM)	0 to 180°F / -18 to 82°C
TE	Fluorinated Ethylene Propylene (FEP)	Ethylene Propylene Diene (EPDM)	-20 to 180°F / -29 to 82°C				

1. Pipe nipples and flanges are 316 Stainless steel for flanged body assemblies.

Table 3. Control Pressure Ranges and Spring Information

CONTROL PRESSURE RANGES		SPRING COLOR	SPRING WIRE DIAMETER		SPRING FREE LENGTH	
In. w.c.	mbar		In.	mm	In.	mm
2.0 to 7.0 ⁽¹⁾⁽²⁾	5 to 17 ⁽¹⁾⁽²⁾	Red	0.085	2.2	3.63	92.2
3.0 to 13.0 ⁽¹⁾⁽²⁾	7 to 32 ⁽¹⁾⁽²⁾	Unpainted	0.105	2.7	3.75	95.3
10.0 to 26.0	25 to 65	Yellow	0.114	2.9	4.31	109
0.9 to 2.5 psig	62 to 172	Green	0.156	4.0	4.06	103
1.3 to 4.5 psig	90 to 310	Light Blue	0.187	4.8	3.94	100
3.8 to 7.0 psig	0.26 to 0.48 bar	Black	0.218	5.5	3.98	101

1. To achieve the published control pressure range the spring case must be installed pointing down.
2. Do not use Fluorocarbon (FKM) diaphragm with these springs at diaphragm temperatures lower than 60°F / 16°C.

Fisher T208 Series

Vapor Recovery Regulator

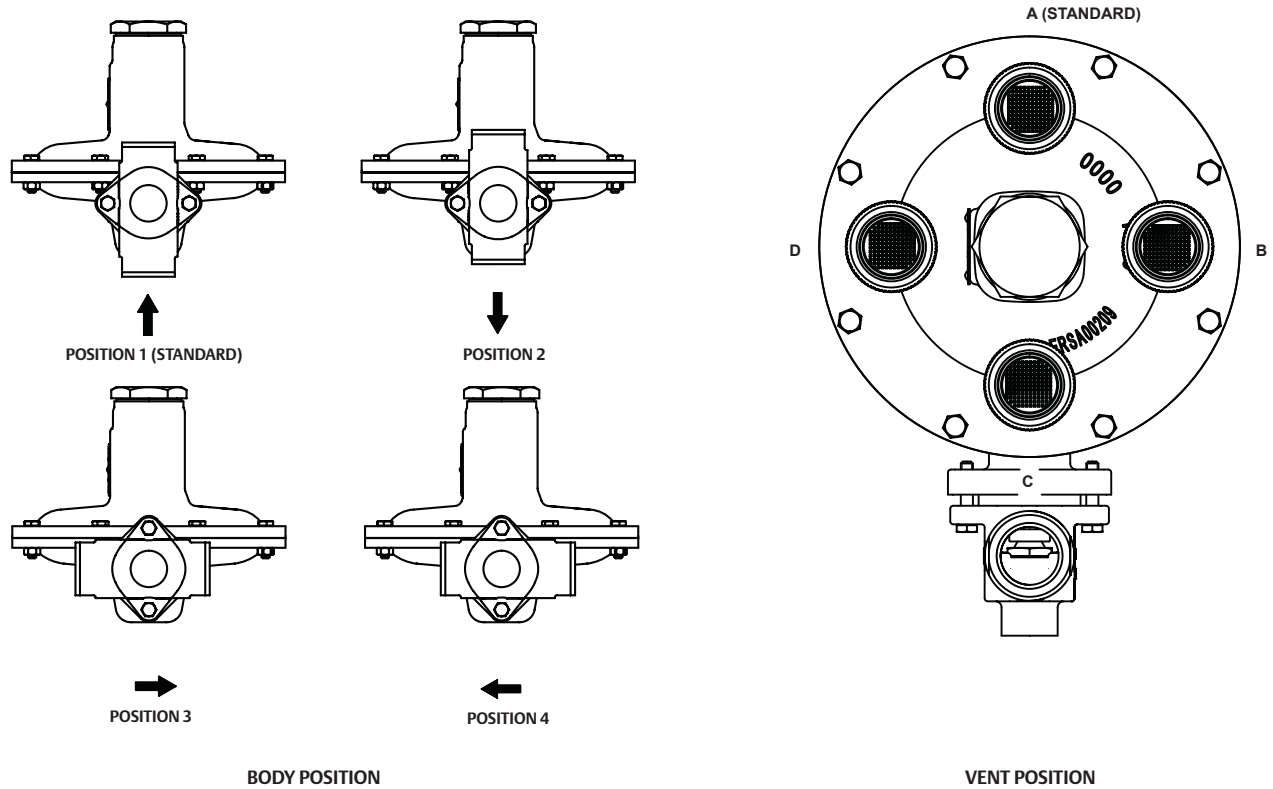

Figure 3. Body and Vent Position

Table 4. Flow and Sizing Coefficients

ORIFICE SIZE		REGULATING			WIDE-OPEN		
In.	mm	C_g	C_v	C_1	C_g	C_v	C_1
7/16	11	94	2.7	35.0	97	2.8	35.0

Table 5. T208 Series C_v Coefficient and Flow Capacity

CONTROL PRESSURE RANGES AND SPRING COLOR	SET PRESSURE		MINIMUM BUILDUP TO WIDE-OPEN		VACUUM OUTLET PRESSURE		C_v COEFFICIENT	CAPACITIES OF AIR	
	In. w.c.	mbar	In. w.c.	mbar	psig	bar g		SCFH	Nm ³ /h
2.0 to 7.0 in. w.c. / 5 to 17 mbar Red	2.0	5.0	4.02	10	0	0	3.1	192	5.1
					2.5	0.17	3.5	1161	31.1
					5	0.34	3.5	1488	39.9
	4.0	10.0	3.62	9	0	0	2.6	226	6.1
					2.5	0.17	3.5	1178	31.6
					5	0.34	3.5	1500	40.2
3.0 to 13.0 in. w.c. / 7 to 32 mbar Unpainted	10.0	25	5.99	15	0	0	2.0	268	7.2
					2.5	0.17	3.5	1232	33.0
					5	0.34	3.5	1539	41.2
10.0 to 26.0 in. w.c. / 25 to 65 mbar Yellow	15	37	8.89	22.1	0	0	2.0	331	8.9
					2.5	0.17	3.5	1279	34.3
					5	0.34	3.5	1574	42.2
0.9 to 2.5 psig / 62 to 172 mbar Green	1 psig	70	0.78 psig	54	0	0	2.2	499	13.4
					2.5	0.17	3.6	1426	38.2
					5	0.34	3.6	1687	45.2
1.3 to 4.5 psig / 90 to 310 mbar Light Blue	2 psig	140	1.49 psig	103	0	0	2.3	752	20.2
					2.5	0.17	3.8	1694	45.4
					5	0.34	3.7	1904	51.0
3.8 to 7.0 psig / 0.26 to 0.48 bar Black	5 psig	340	2.79 psig	192	0	0	2.2	1139	30.5
					2.5	0.17	3.8	2286	61.3
					5	0.34	3.8	2242	60.1

Fisher T208 Series

Vapor Recovery Regulator

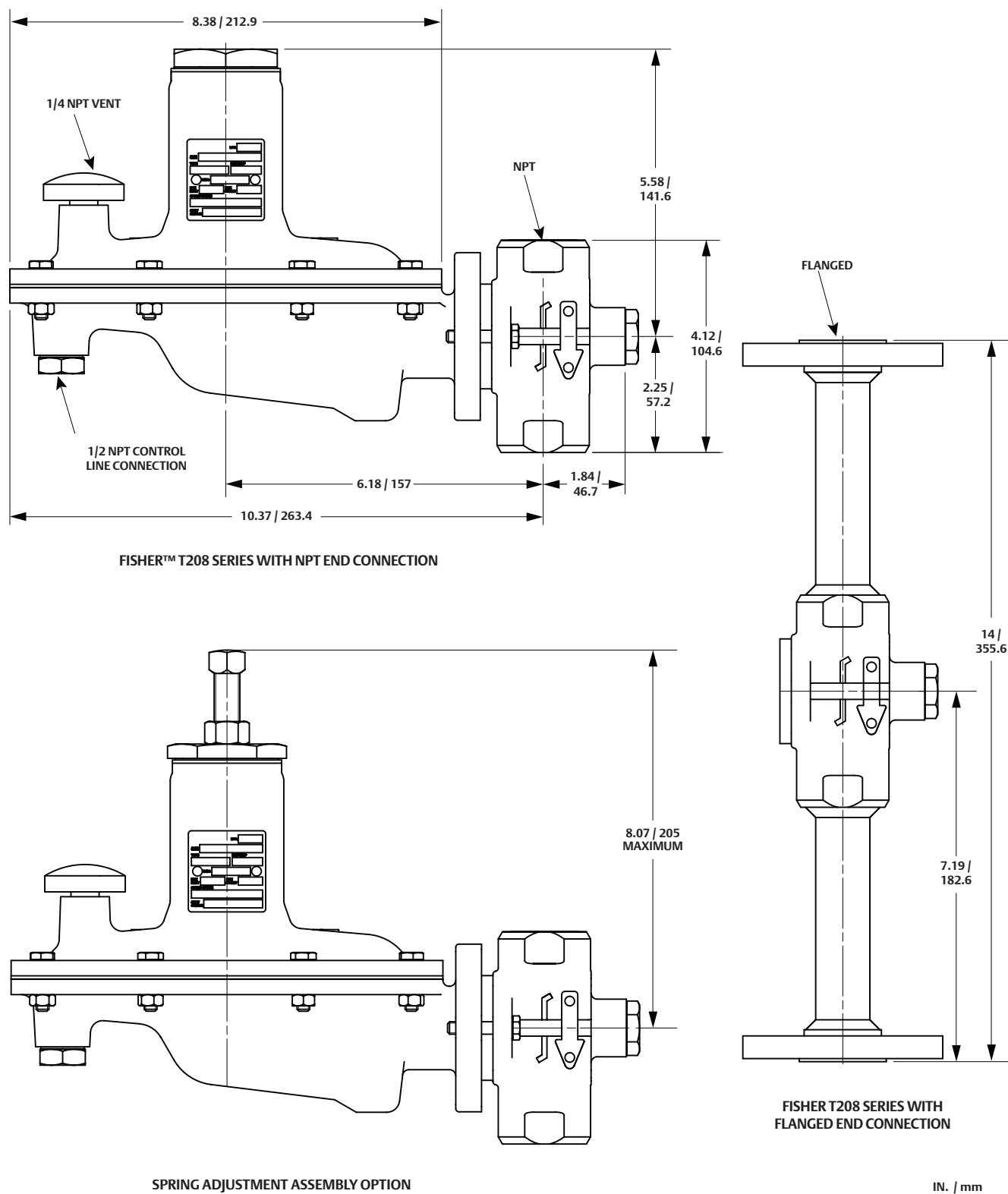

Figure 4. Dimensions

Ordering Guide

Type (Select One) <input type="checkbox"/> T208, Internal pressure registration*** <input type="checkbox"/> T208M, External pressure registration***
Body Size (Select One) <input type="checkbox"/> 3/4 in. / DN 20*** <input type="checkbox"/> 1 in. / DN 25***
Body Material and End Connection Style (Select One) Gray cast iron <input type="checkbox"/> NPT*** WCC Carbon steel <input type="checkbox"/> NPT*** <input type="checkbox"/> CL150 RF*** <input type="checkbox"/> CL300 RF*** <input type="checkbox"/> PN 16/25/40 RF*** specify rating _____ CF8M/CF3M Stainless steel⁽¹⁾ <input type="checkbox"/> NPT*** <input type="checkbox"/> CL150 RF*** <input type="checkbox"/> CL300 RF*** <input type="checkbox"/> PN 16/25/40 RF*** specify rating _____
Control Pressure Range (Select One) <input type="checkbox"/> 2.0 to 7.0 in. w.c. / 5 to 17 mbar, Red*** <input type="checkbox"/> 3.0 to 13.0 in. w.c. / 7 to 32 mbar, Unpainted*** <input type="checkbox"/> 10.0 to 26.0 in. w.c. / 25 to 65 mbar, Yellow*** <input type="checkbox"/> 0.9 to 2.5 psig / 62 to 172 mbar, Green*** <input type="checkbox"/> 1.3 to 4.5 psig / 90 to 310 bar, Light Blue*** <input type="checkbox"/> 3.8 to 7 psig / 0.26 to 0.48 bar, Black***
Trim Material (See Table 2, Select One) <input type="checkbox"/> Standard *** <input type="checkbox"/> VV*** <input type="checkbox"/> TV*** <input type="checkbox"/> TN*** <input type="checkbox"/> TK*** <input type="checkbox"/> TE***

Adjusting Screw (Select One) <input type="checkbox"/> Internal Flat Circular (standard)*** <input type="checkbox"/> External Square Head (Available for Green, Light Blue and Black springs only. Steel closing cap is automatically supplied in this option)***
Closing Cap Material (Select One) <input type="checkbox"/> Plastic (standard) (not available for Green, Light Blue and Black springs)*** <input type="checkbox"/> Steel (standard for Green, Light Blue and Black springs)*** <input type="checkbox"/> Stainless steel***
Body Position (See Figure 3, Select One) <input type="checkbox"/> Position 1 (standard)*** <input type="checkbox"/> Position 2*** <input type="checkbox"/> Position 3*** <input type="checkbox"/> Position 4***
Spring Case Orientation/Vent Type (Select One) <input type="checkbox"/> Spring Case Down (Fisher™ Type Y602-1) (standard)*** <input type="checkbox"/> Spring Case Up (Fisher Type Y602-11)***
Vent Position (See Figure 3) (Select One) <input type="checkbox"/> Position A (standard)*** <input type="checkbox"/> Position B*** <input type="checkbox"/> Position C*** <input type="checkbox"/> Position D***
NACE Standard MR0175-2002 Construction (Select One) <input type="checkbox"/> Yes <input type="checkbox"/> No
Replacement Parts Kit (Optional) <input type="checkbox"/> Yes, send one replacement parts kit to match this order.

- continued -

1. Pipe nipples and flanges are 316 Stainless steel for flanged body assemblies.

Fisher T208 Series

Vapor Recovery Regulator

Ordering Guide (continued)

To order this product, complete the Ordering Guide Section or complete the Specification Worksheet and forward to your local Sales Office.

If the construction you need is not offered in the ordering guide section, contact your local Sales Office.

To locate your local Sales Office log on to:
www.fisher.com

Regulators Quick Order Guide	
***	Readily Available for Shipment
**	Allow Additional Time for Shipment
*	Special Order, Constructed from Non-Stocked Parts. Consult your local Sales Office for Availability.
Availability of the product being ordered is determined by the component with the longest shipping time for the requested construction.	

Specification Worksheet
Application
Tank Capacity:
Pump In Rate:
Pump Out Rate:
Blanketing Gas Type:
Blanketing Gas Specific Gravity:
Boiling and Flash Point of Stored Material:
Is tank blanketing regulator required? <input type="checkbox"/> Yes <input type="checkbox"/> No
Pressure
Control Pressure Setting:
Downstream Pressure:
Maximum Flow (Q_{max}):
Performance Required
Buildup Limitations:
<input type="checkbox"/> 0.25 in. w.c. / 0.6 mbar <input type="checkbox"/> 0.50 in. w.c. / 1 mbar
<input type="checkbox"/> 1 in. w.c. / 2 mbar <input type="checkbox"/> 2 in. w.c. / 5 mbar
<input type="checkbox"/> Others _____
Other Requirements:



The distinctive diamond shape cast into every spring case uniquely identifies the regulator as part of the Fisher™ brand and assures you of the highest-quality engineering, durability, performance and support.

Fisher Type 1290

Vapor Recovery Regulator

Introduction

The Fisher™ Type 1290 vapor recovery regulator controls vessel blanketing gas pressure when the vessel is being filled with fluid or when ambient temperature causes the vapor gas to expand. The system monitors the increasing tank pressure and throttles open to pass excess blanketing gas into a vapor disposal or reclamation system thus controlling the desired set pressure of the vessel.

The vapor recovery regulator is not intended to be used as an ASME certified relief device for overpressure protection. It is to be used as part of the gas blanketing system to control the outflow of blanketing gas under normal conditions and to collect vessel vapors for the vapor disposal or reclamation system. You should provide alternate methods of emergency overpressure protection per the American Petroleum Institute Standard 2000 (API 2000).

The vapor recovery regulator responds to any changes in the blanket gas pressure and throttles open or closed to control the flow of the blanket gas out of the vessel. A vacuum source on the outlet of the regulator is usually necessary to ensure flow of low pressure blanket gas out of the vessel into a vapor disposal or reclamation system. The higher the vacuum pressure of the vacuum source, the higher the flow capacity of the vapor recovery regulator.

Body Sizes and End Connection Styles

See Table 1

Flow Capacities

See Table 7

IEC Sizing Coefficients

See Table 6

Maximum Inlet Pressure

See Table 4

Control Pressure Ranges

0.5 in. w.c. to 7 psig /
1 mbar to 0.5 bar in eight ranges
See Table 3

Temperature Capabilities

Nitrile (NBR)
-20 to 180°F / -29 to 82°C

Fluorocarbon (FKM)
For In. w.c. Setpoints:
40 to 300°F / 4 to 149°C
For psig Setpoints:
0 to 300°F / -18 to 149°C

Ethylenepropylene (EPDM)
-20 to 275°F / -29 to 135°C

Perfluoroelastomer (FFKM)
-20 to 300°F / -29 to 149°C

Pressure Registration

External

Additional Technical Data

For more technical information, contact your local Sales Office or log on to:

www.fisher.com



Figure 1. Fisher Type 1290 Vapor Recovery Regulator

Features

- Quick-Change Trim Package
- Easy In-Line Maintenance
- High Accuracy
- Proven Technology
- Setpoints as Low as 0.5 in. w.c. / 1 mbar
- Whisper Trim® Cage
- In-Service Travel Inspection

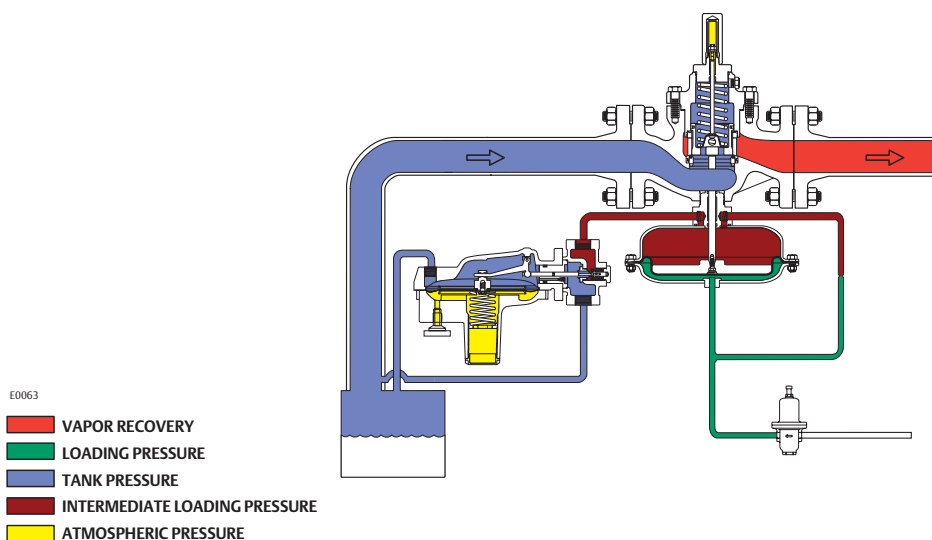

Figure 2. Operational Schematic

Fisher Type 1290

Vapor Recovery Regulator

Table 1. Body Sizes and End Connection Styles

BODY SIZE		BODY MATERIAL	END CONNECTION STYLE
NPS	DN		
1 and 2	25 and 50	Cast iron	NPT, CL125 FF or CL250 RF flanged
		WCC Steel or Stainless steel	NPT, SWE, BWE, CL150 RF, CL300 RF, CL600 RF or PN 16/25/40 flanged
3, 4 or 6	80, 100 or 150	Cast iron	CL125 FF CL50 RF flanged
		WCC Steel or Stainless steel	BWE, CL150 RF, CL300 RF, CL600 RF or PN 16 flanged
8 x 6 or 12 x 6	200 x 150 or 300 x 150	WCC Steel or Stainless steel	BWE, CL150 RF, CL300 RF, CL600 RF or PN 25 flanged

Table 2. Construction Materials⁽¹⁾

MAIN VALVE				SIZE 40 ACTUATOR	PILOT	SUPPLY REGULATOR	DIAPHRAGM	O-RING AND SEAL
Body and Body Flange	Plug and Seat Ring	Spring	Cage					
Cast iron	416 Stainless steel	Steel	Cast iron	Steel	Ductile iron	Cast iron	Nitrile (NBR), Fluorocarbon (FKM) or Ethylenepropylene (EPDM)	Nitrile (NBR), Fluorocarbon (FKM), Ethylenepropylene (EPDM) or Perfluoroelastomer (FFKM)
WCC Steel	416 Stainless steel	Steel	Steel	Steel	Ductile iron	WCC Steel		
CF8M Stainless steel	316 Stainless steel	Inconel® X750	316 Stainless steel Whisper Trim™ Cage	Stainless steel	CF8M Stainless steel	CF8M Stainless steel		

1. Fisher™ offers special construction materials for system compatibility. Contact your local Sales Office for additional information.

Table 3. Control Pressure Ranges

PILOT TYPE	CONTROL PRESSURE RANGE ⁽¹⁾ , IN. W.C. / mbar	SPRING COLOR	SPRING PART NUMBER	BUILDUP TO WIDE-OPEN, IN. W.C. / mbar	SPRING WIRE DIAMETER		SPRING FREE LENGTH	
					In.	mm	In.	mm
T208PL	0.5 to 1.5 / 1 to 4 ⁽²⁾	Black	1B413627222	0.25 / 0.60	0.075	1.90	2.19	56.0
T208P	1 to 2.5 / 2 to 6 ⁽²⁾⁽³⁾ 2 to 7 / 5 to 17 ⁽²⁾⁽⁴⁾ 4 to 14 / 10 to 35 12 to 28 / 30 to 70 1.0 to 2.5 psig / 0.07 to 0.17 bar 2.5 to 4.5 psig / 0.17 to 0.31 bar 4.5 to 7 psig / 0.31 to 0.48 bar	Orange	1B558527052	0.25 / 0.60	0.072	1.83	3.78	96.0
		Red	1B653827052	0.25 / 0.60	0.085	2.20	3.63	92.0
		Unpainted	1B653927022	0.25 / 0.60	0.100	2.70	3.75	95.0
		Yellow	1B537027052	1.4 / 3	0.114	2.90	4.31	109
		Green	1B537127022	2.8 / 7	0.156	4.00	4.06	103
		Light blue	1B537227022	4.2 / 10	0.187	4.80	3.94	100
		Black	1B537327052	5.5 / 14	0.218	5.40	3.98	101

- Spring ranges based on pilot being installed with the spring case pointed down.
- Do not use Fluorocarbon (FKM) diaphragm with this spring at diaphragm temperatures lower than 60°F / 16°C.
- When using a Fluorocarbon (FKM) diaphragm, the minimum outlet pressure is 2 in. w.c. / 5 mbar.
- When using a Fluorocarbon (FKM) diaphragm, the minimum outlet pressure is 2.5 in. w.c. / 6 mbar.

Table 4. Maximum Inlet Pressures

TYPE	MAXIMUM INLET PRESSURE, psig / bar					SPRING COLOR
	Fisher Type 1089-EGR Main Valve with Green Spring					
	1 In. / DN 25	2 In. / DN 50	3 In. / DN 80	4 In. / DN 100	6 or 8 x 6 In. / DN 150 or 200 x 150	
T208PL	5.5 / 0.38	5 / 0.35	4 / 0.28	3 / 0.21	3.5 / 0.24	Black
T208P	5.5 / 0.38	5 / 0.35	4 / 0.28	3 / 0.21	3.5 / 0.24	Orange
	5.5 / 0.38	5 / 0.35	4 / 0.28	3 / 0.21	3.5 / 0.24	Red
	6.5 / 0.45	6 / 0.41	5 / 0.35	4 / 0.28	4.5 / 0.31	Olive Drab
	7.5 / 0.52	7 / 0.48	6 / 0.41	5 / 0.35	4.5 / 0.31	Yellow
	8.5 / 0.59	8 / 0.55	7 / 0.48	6 / 0.41	5.5 / 0.38	Light Green
	11.5 / 0.79	11 / 0.76	10 / 0.69	9 / 0.62	8.5 / 0.59	Light Blue
	12.5 / 0.86	12 / 0.83	11 / 0.76	10 / 0.69	10.5 / 0.72	Black

Inconel® is a mark owned by Special Metals Corporation.



Fisher Type 1290

Vapor Recovery Regulator

Table 5. Flow Coefficients

BODY SIZE, NPS / DN	PIPING STYLE											
	Line Size Equals Body Size Piping											
	Linear Cage					Drilled Hole Whisper Trim™ Cage						
	C _g		C _v		C ₁	K _m	C _g		C _v		C ₁	K _m
Regulating	Wide-Open	Regulating	Wide-Open	Regulating			Wide-Open	Regulating	Wide-Open			
1 / 25	600	632	16.8	17.7	35.7	0.70	576	607	16.7	17.6	34.5	0.80
2 / 50	2280	2400	63.3	66.7	36.0		1970	2080	54.7	57.8	36.0	
3 / 80	4630	4880	132	139	35.1		3760	3960	107	113	35.0	
4 / 100	7320	7710	202	213	36.2		6280	6610	180	190	34.8	
6 / 150	12,900	13,600	397	418	32.5		9450	9950	295	310	32.0	
8 x 6 / 200 x 150	18,480	19,450	578	608	32.0		10,660	11,220	305	321	35.0	
12 x 6 / 300 x 150	21,180	22,290	662	697	32.0		11,050	11,630	316	332	35.0	
BODY SIZE, NPS / DN	PIPING STYLE											
	2:1 Line Size to Body Size Piping											
	Standard Linear Cage					Drilled Hole Whisper Trim Cage						
	C _g		C _v		C ₁	K _m	C _g		C _v		C ₁	K _m
Regulating	Wide-Open	Regulating	Wide-Open	Regulating			Wide-Open	Regulating	Wide-Open			
1 / 25	568	598	17.2	18.1	33.0	0.70	529	557	15.6	16.4	34.0	0.80
2 / 50	2050	2160	59.6	62.8	34.4		1830	1930	52.3	55.1	35.1	
3 / 80	4410	4650	128	135	34.4		3630	3830	106	110	34.2	
4 / 100	6940	7310	198	209	35.0		6020	6340	171	180	35.2	
6 / 150	12,100	12,800	381	404	31.7		9240	9730	291	306	31.7	
8 x 6 / 200 x 150	17,370	18,280	543	571	32.0		10,020	10,550	286	301	35.0	
12 x 6 / 300 x 150	19,900	20,950	622	655	32.0		10,380	10,930	297	312	35.0	

Table 6. IEC Sizing Coefficients

BODY SIZE, IN. / DN	X _T	F _D	F _L
1 / 25	0.81	0.43	0.84
2 / 50	0.82	0.35	
3 / 80	0.78	0.30	
4 / 100	0.83	0.28	
6 / 150	0.67	0.28	
8 x 6 / 200 x 150 ⁽¹⁾	0.78	0.33	

1. Standard cage for all sizes.

Fisher Type 1290

Vapor Recovery Regulator

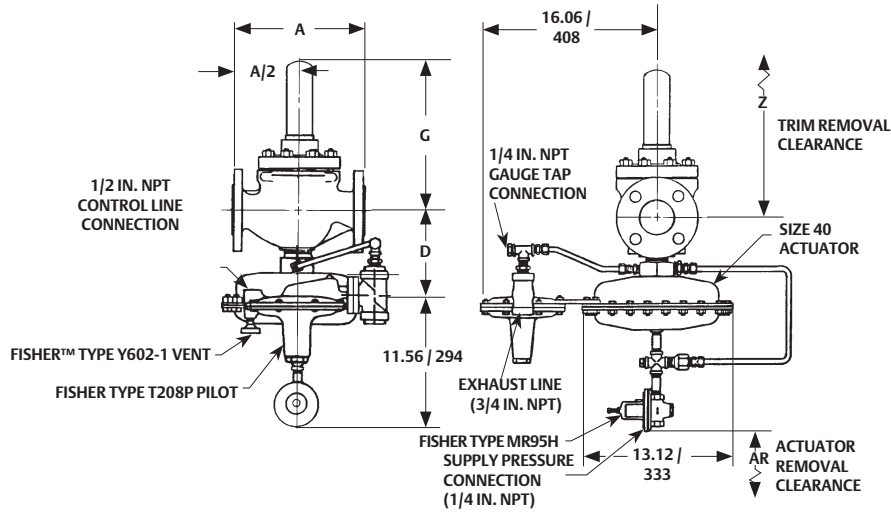

Figure 3. Dimensions

Table 7. Capacities

PILOT TYPE	PILOT SPRING COLOR	CONTROL PRESSURE	BUILDUP OVER CONTROL PRESSURE TO WIDE-OPEN ⁽¹⁾	DOWNSTREAM VACUUM PRESSURE	CAPACITIES IN SCFH / Nm ³ /h OF 0.97 SPECIFIC GRAVITY NITROGEN				
					NPS 1 / DN 25 Body	NPS 2 / DN 50 Body	NPS 3 / DN 80 Body	NPS 4 / DN 100 Body	NPS 6 / DN 150 Body
T208PL	Black	0.5 in. w.c. / 1 mbar	0.25 in. w.c. / 0.60 mbar	0 psig / 0 bar 2.5 psig / 0.17 bar 5 psig / 0.34 bar	600 / 16.1 5600 / 150 7300 / 196	2300 / 61.6 19,900 / 533 25,800 / 691	4900 / 131 43,100 / 1155 55,700 / 1493	7600 / 204 66,900 / 1793 86,700 / 2324	14,600 / 391 124,500 / 3337 160,600 / 4304
T208P	Orange	1 in. w.c. / 2 mbar	0.25 in. w.c. / 0.60 mbar	0 psig / 0 bar 2.5 psig / 0.17 bar 5 psig / 0.34 bar	700 / 18.8 5700 / 153 7400 / 198	2700 / 72.4 10,000 / 268 25,900 / 694	5900 / 158 43,200 / 1158 55,800 / 1495	9200 / 247 67,000 / 1796 86,800 / 2326	17,700 / 474 126,700 / 3396 160,800 / 4309
		2 in. w.c. / 5 mbar	0.25 in. w.c. / 0.60 mbar	0 psig / 0 bar 2.5 psig / 0.17 bar 5 psig / 0.34 bar	1100 / 29.5 5800 / 155 7400 / 198	3900 / 105 20,200 / 541 26,000 / 697	8400 / 225 43,500 / 1166 56,000 / 1501	13,000 / 348 67,600 / 1812 87,200 / 2337	25,000 / 670 127,700 / 3422 161,500 / 4328
	Unpainted	4 in. w.c. / 10 mbar	0.25 in. w.c. / 0.60 mbar	0 psig / 0 bar 2.5 psig / 0.17 bar 5 psig / 0.34 bar	1500 / 40.2 5800 / 155 7500 / 201	5300 / 142 20,500 / 549 26,300 / 705	11,500 / 308 44,100 / 1182 56,600 / 1517	17,800 / 477 68,500 / 1836 88,100 / 2361	34,200 / 917 129,400 / 3468 162,200 / 4347
		8 in. w.c. / 20 mbar	0.25 in. w.c. / 0.60 mbar	0 psig / 0 bar 2.5 psig / 0.17 bar 5 psig / 0.34 bar	2100 / 56.3 6000 / 161 7600 / 204	7400 / 198 21,000 / 563 26,800 / 718	16,000 / 429 45,300 / 1214 57,700 / 1546	24,800 / 665 70,400 / 1887 89,800 / 2407	47,600 / 1276 132,800 / 3559 166,200 / 4454
	Yellow	15 in. w.c. / 37 mbar	0.25 in. w.c. / 0.60 mbar	0 psig / 0 bar 2.5 psig / 0.17 bar 5 psig / 0.34 bar	2900 / 77.7 6300 / 169 7900 / 212	10,100 / 271 22,000 / 590 27,800 / 745	21,800 / 584 47,400 / 1270 59,800 / 1603	33,800 / 906 73,600 / 1972 93,100 / 2495	64,900 / 1739 138,700 / 3717 172,400 / 4620
		1 psig / 0.07 bar	0.05 psig / 3 mbar	0 psig / 0 bar 2.5 psig / 0.17 bar 5 psig / 0.34 bar	4000 / 107 6800 / 182 8100 / 217	14,100 / 378 23,900 / 641 28,700 / 769	30,500 / 817 51,400 / 1378 61,800 / 1656	47,200 / 1265 79,900 / 2141 96,200 / 2578	90,300 / 2420 150,100 / 4023 177,200 / 4749
	Light blue	3 psig / 0.21 bar	0.15 psig / 10 mbar	0 psig / 0 bar 2.5 psig / 0.17 bar 5 psig / 0.34 bar	7000 / 188 8700 / 233 9600 / 257	24,700 / 662 30,600 / 820 34,100 / 914	53,200 / 1426 66,000 / 1769 73,400 / 1967	82,500 / 2211 102,700 / 2752 114,600 / 3071	155,800 / 4175 190,700 / 5111 209,100 / 5604
		5 psig / 0.34 bar	0.15 psig / 10 mbar	0 psig / 0 bar 2.5 psig / 0.17 bar 5 psig / 0.34 bar	9100 / 244 10,200 / 273 11,000 / 295	31,900 / 855 36,300 / 973 39,000 / 1045	68,600 / 1838 78,100 / 2093 83,900 / 2249	106,700 / 2860 121,600 / 3259 131,000 / 3511	199,500 / 5347 224,000 / 6003 327,400 / 8774
	Black	7 psig / 0.48 bar	0.20 psig / 14 mbar	0 psig / 0 bar 2.5 psig / 0.17 bar 5 psig / 0.34 bar	10,800 / 289 11,700 / 314 12,300 / 330	38,200 / 1024 41,600 / 1115 43,800 / 1174	82,200 / 2203 89,500 / 2399 94,200 / 2525	127,900 / 3428 139,700 / 3744 147,300 / 3948	237,100 / 6354 255,300 / 6842 265,100 / 7105

1. Increased capacity is available at higher buildups.

Table 8. Dimensions and Shipping Weights

MAIN VALVE BODY SIZE, IN. / DN	DIMENSIONS, IN. / mm									APPROXIMATE SHIPPING WEIGHT, lbs / kg	
	A				D	G	Z		AR		
	NPT	CL125 FF Cast Iron or CL150 RF Steel or Stainless Steel	CL250 FF Cast Iron or CL300 RF Steel or Stainless Steel				Cast Iron	Stainless Steel or Steel	Cast Iron		Stainless Steel or Steel
1 / 25	8.25 / 210	7.25 / 184	7.75 / 197	3.88 / 99	8.62 / 219	12.00 / 305	10.50 / 267	3.00 / 76	2.44 / 62	85 / 39	
2 / 50	11.25 / 286	10 / 254	10.50 / 267	4.56 / 116	9.12 / 232	13.31 / 338	11.81 / 300	3.12 / 79	3.12 / 79	100 / 45	
3 / 80	----	11.75 / 298	12.50 / 317	5.31 / 135	11.25 / 286	16.50 / 419	14.00 / 356	3.88 / 99	3.88 / 99	145 / 66	
4 / 100	----	13.88 / 353	14.50 / 368	6.50 / 165	12.62 / 321	19.12 / 486	16.88 / 429	5.12 / 130	5.12 / 130	195 / 88	
6 / 150	----	17.75 / 451	18.62 / 473	7.25 / 184	13.69 / 348	20.44 / 519	19.19 / 487	6.38 / 162	6.62 / 168	380 / 172	
8 x 6 / 200 x 150	----	29 / 737	30.5 / 775	9.76 / 248	15.02 / 382	20.25 / 514	23.25 / 591	6.62 / 168	6.62 / 168	740 / 336	

Ordering Guide

Construction (Select One)

Standard

NACE

Fisher™ Type EGR Main Valve

Main Valve Body Size (Select One)

NPS 1 / DN 25*** NPS 6 / DN 150**

NPS 2 / DN 50*** NPS 8 x 6 / DN 200 x 150*

NPS 3 / DN 80*** NPS 12 x 6 / DN 300 x 150*

NPS 4 / DN 100***

Main Valve Body Material (Select One)

Cast iron***

WCC Steel***

CF8M Stainless steel (NACE)**

Main Valve End Connection Style (Select One)

Cast Iron Body

NPT (NPS 1 and 2 / DN 25 and 50 only)***

CL125 FF***

CL250 RF***

WCC Steel or CF8M Stainless Steel Body

NPT (NPS 1 and 2 / DN 25 and 50 only)***

SWE (NPS 1 and 2 / DN 25 and 50 only)*

CL150 RF***

CL300 RF***

CL600 RF***

BWE 40**

BWE 80*

PN 16/25/40** _____ please specify rating

Main Valve Body Flange Material (Select One)

Cast iron***

WCC Steel***

CF8M Stainless steel (NACE)**

Percent Travel or Travel Stop (Select One)

100 percent (standard)***

70 percent (NPS 2 / DN 50 only)**

40 percent (Not available for NPS 1 and 2 / DN 25 and 50)**

30 percent (NPS 2 / DN 50 only)**

Main Valve Cage Type and Material (Select One)

Linear, CF8M Stainless steel, NACE***

Whisper Trim™ Cage, 416 Stainless steel

Whisper Trim Cage, 316 Stainless steel (NACE)

Quick Opening, Cast iron

Quick Opening, Steel (for NPS 6 / DN 150 body only)

Main Valve Spring Range (Select One)

60 psig / 4.1 bar maximum drop, Green**

Fisher Type EGR Main Valve (continued)

Main Valve Spring (Select One)

Steel***

Inconel® X750 (NACE)***

O-ring and Seal Material (Select One)

Nitrile (NBR)***

Fluorocarbon (FKM)**

Ethylenepropylene (EPDM)**

Perfluoroelastomer (FFKM)

Fisher Type 1098 Actuator

Lower Diaphragm Case Material (Select One)

Steel***

Stainless steel (NACE)**

Bonnet Material (Select One)

Steel***

Stainless steel (NACE)**

O-ring Material (Select One)

Nitrile (NBR)***

Fluorocarbon (FKM)**

Ethylenepropylene (EPDM)**

Diaphragm Material (Select One)

Nitrile (NBR)***

Fluorocarbon (FKM)**

Ethylenepropylene (EPDM)**

Fisher Type MR95H Supply Pressure Regulator

Body Material (Select One)

Cast iron***

Steel***

Stainless steel (NACE)***

Spring Case Material (Select One)

Cast iron***

Steel***

Stainless steel***

Valve Plug Material (Select One)

416 Stainless steel with Nitrile (NBR)***

416 Stainless steel with Fluorocarbon (FKM)***

316 Stainless steel with Neoprene (CR) (NACE)**

316 Stainless Steel with Fluorocarbon (FKM)**

Outlet Pressure Range (Select One)

15 to 30 psig / 1.0 to 2.1 bar, Yellow***

Diaphragm Material (Select One)

Neoprene (CR)***

Fluorocarbon (FKM)**

- continued -

Inconel® is a mark owned by Special Metals Corporation.

Fisher Type 1290

Vapor Recovery Regulator

Ordering Guide (continued)

Fisher™ Type T208P or T208PL Pilot

Body, Spring Case Assembly and Diaphragm Casing Material (Select One)

- Ductile iron***
- Stainless steel***

Control Pressure Ranges (Select One)

Fisher Type T208PL

- 0.5 to 1.5 in. w.c. / 1 to 4 mbar***

Fisher Type T208P

- 1.0 to 2.5 in. w.c. / 2 to 6 mbar, Orange***
- 2 to 7 in. w.c. / 5 to 17 mbar, Red***
- 4 to 14 in. w.c. / 10 to 35 mbar, Unpainted***
- 12 to 28 in. w.c. / 30 to 70 mbar, Yellow***
- 1 to 2.5 psig / 69 to 172 mbar, Green***
- 2.5 to 4.5 psig / 172 mbar to 0.3 bar, Light Blue***
- 4.5 to 7 psig / 0.31 to 0.48 bar, Black***

Diaphragm Material (Select One)

- Nitrile (NBR)**
- Fluorocarbon (FKM)**
- Nitrile (NBR) with Polytetrafluoroethylene (PTFE) diaphragm protector**

O-ring and Seal Material (Select One)

- Nitrile (NBR)**
- Fluorocarbon (FKM)**
- Ethylenepropylene (EPDM)**
- Perfluoroelastomer (FFKM)*

To order this product, complete the Ordering Guide Section or complete the Specification Worksheet and forward to your local Sales Office.

If the construction you need is not offered in the ordering guide section, contact your local Sales Office.

To locate your local Sales Office log on to: www.fisher.com

Regulators Quick Order Guide	
***	Readily Available for Shipment
**	Allow Additional Time for Shipment
*	Special Order, Constructed from Non-Stocked Parts. Consult your local Sales Office for Availability.
Availability of the product being ordered is determined by the component with the longest shipping time for the requested construction.	

Fisher Type T208P or T208PL Pilot (continued)

Closing Cap Material (Select One)

Fisher Type T208PL

- Zinc

Fisher Type T208P

- Plastic***
- Steel**
- Stainless steel**

Vent Assembly (Select One)

- Spring Case Up (Fisher Type Y602-11)***
- Spring Case Down (Fisher Type Y602-1)***

Parts Kits

Replacement Parts Kit (Optional)

- Yes, send one replacement parts kit to match this order for each unit.

Quick-Change Trim Package (Optional)

- Yes, send one main valve Quick-Change Trim Package to match this order.

Wireless Position Monitor Mounting Kit (Optional)

- Yes, send one mounting kit for mounting the Topworx™ 4310 or the Fisher™ 4320 wireless position monitor.

Specification Worksheet

Application
Tank Capacity:
Pump In Rate:
Pump Out Rate:
Blanketing Gas Type:
Blanketing Gas Specific Gravity:
Conservation Vent Setpoint:
Is a vapor recovery regulator required? <input type="checkbox"/> Yes <input type="checkbox"/> No
Pressure
Maximum Inlet Pressure (P_{1max}):
Minimum Inlet Pressure (P_{1min}):
Control Pressure Setting (P_2):
Maximum Flow (Q_{max}):
Performance Required
Accuracy Requirements?
Other Requirements:

Technical Data



Conversion Factors

Technical Data

Length		
MULTIPLY	BY	TO OBTAIN
Centimeter (cm)	0.3937	Inch (in.)
Circumference of circle	0.3183	Diameter
Diameter of circle	3.1416	Circumference
Feet (ft.)	12.0	Inch (in.)
Inch (in.)	2.54	Centimeter (cm)
Inch (in.)	0.0833	Feet (ft.)
Inch (in.)	0.0254	Meter (m)
Inch (in.)	25.4	Millimeter (mm)
Meter (m)	3.281	Feet (ft.)
Meter (m)	1000	Millimeter (mm)
Millimeter (mm)	0.03937	Inch (in.)
Millimeter (mm)	0.001	Meter (m)

Area		
MULTIPLY	BY	TO OBTAIN
cm ²	0.155	in ²
(Diameter of circle) ²	0.7854	Area
(Diameter of sphere) ²	3.1416	Surface
ft ²	144	in ²
ft ²	0.0929	m ²
in ²	6.4516	cm ²
in ²	0.00694	ft ²
in ²	645.16	mm ²
m ²	10.764	ft ²
mm ²	0.00155	in ²

Weight		
MULTIPLY	BY	TO OBTAIN
kg	2.2046	lb
kg	35.27	Ounce (av)
lb	0.4536	kg
lb	16	Ounce (av)
Ounce (av)	0.02834	kg
Ounce (av)	0.06250	lb

Volume		
MULTIPLY	BY	TO OBTAIN
Barrel, oil	5.6146	ft ³
Barrel, oil	9702	in ³
Barrel, oil	158.98	Liter
Barrel, oil	0.15899	m ³
Barrel, oil	42	U.S. gallon
cm ³	0.03381	Ounce (fl)
(Diameter of sphere) ³	0.5236	Volume
ft ³	0.1781	Barrel, oil
ft ³	1728	in ³
ft ³	28.317	Liter
ft ³	0.028317	m ³
ft ³	7.4805	U.S. gallon
Imperial gallon	0.028594	Barrel, oil
Imperial gallon	1.2009	U.S. gallon
in ³	16.387	cm ³
in ³	0.0005787	ft ³
in ³	0.01639	Liter
Liter	0.00629	Barrel, oil
Liter	0.03531	ft ³
Liter	61.0234	in ³
Liter	33.81	Ounce (fl)
Liter	0.264178	U.S. gallon
m ³	35.315	ft ³
m ³	264.2	U.S. gallon
Ounce (fl)	29.574	cm ³
Ounce (fl)	0.029574	Liter
U.S. gallon	0.02381	Barrel, oil
U.S. gallon	0.13368	ft ³
U.S. gallon	0.833	Imperial gallon
U.S. gallon	3.78543	Liter
U.S. gallon	0.00379	m ³

Conversion Factors

Technical Data

Pressure		
MULTIPLY	BY	TO OBTAIN
Atmosphere	101.325	kPa
Atmosphere	14.696	lb/in ² (psi)
bar	1.01972	kg/cm ²
bar	100	kPa
bar	14.5038	lb/in ² (psi)
Inch Hg	0.03453	kg/cm ²
Inch Hg	3.3864	kPa
Inch Hg	0.4912	lb/in ² (psi)
Inch Hg	7.8585	oz./in ²
kg/cm ²	0.98067	bar
kg/cm ²	28.96	Inch Hg
kg/cm ²	98.067	kPa
kg/cm ²	14.22	lb/in ² (psi)
kPa	0.0098696	Atmosphere
kPa	0.01	bar
kPa	0.2953	inch Hg
kPa	0.0101972	kg/cm ²
kPa	0.145038	lb/in ² (psi)
lb/in ² (psi)	0.06804	Atmosphere
lb/in ² (psi)	0.06895	bar
lb/in ² (psi)	2.036	Inch Hg
lb/in ² (psi)	0.07031	kg/cm ²
lb/in ² (psi)	6.895	kPa
lb/in ² (psi)	51.715	mm Hg
mbar	0.014504	lb/in ² (psi)
mm Hg	0.039370	Inch Hg
mm Hg	0.0013595	kg/cm ²
mm Hg	0.019337	lb/in ² (psi)
oz./ft ²	0.30515	kg/m ²
oz./in ²	0.127	Inch Hg
oz./in ²	0.06250	lb/in ² (psi)

Note: Hg at 32°F / 0°C

Temperature		
MULTIPLY	BY	TO OBTAIN
(°F - 32)	5/9	°C
[(°C X 1.8) + 32]	1.0	°F
(°C + 273.16)	1.0	K (Kelvin)
(°F + 459.69)	1.0	Rankine

Water Factors		
MULTIPLY	BY	TO OBTAIN
Bar	401.47	Inch H ₂ O (in. w.c.)
Inch Hg	13.5954	Inch H ₂ O (in. w.c.)
Inch H ₂ O (in. w.c.)	0.07355	Inch Hg
Inch H ₂ O (in. w.c.)	25.4	mm H ₂ O
Inch H ₂ O (in. w.c.)	0.5780	oz./in ²
Inch H ₂ O (in. w.c.)	0.03613	lb/in ² (psi)
Inch H ₂ O (in. w.c.)	0.00249	bar
Inch H ₂ O (in. w.c.)	0.00254	kg/cm ²
Inch H ₂ O (in. w.c.)	0.24908	kPa
Inch H ₂ O (in. w.c.)	1.8683	mm Hg
kg/cm ²	393.72	Inch H ₂ O (in. w.c.)
kPa	4.0147	Inch H ₂ O (in. w.c.)
lb/in ² (psi)	27.68	Inch H ₂ O (in. w.c.)
mbar	0.40147	Inch H ₂ O (in. w.c.)
mm Hg	0.53525	Inch H ₂ O (in. w.c.)
mm H ₂ O	0.03937	Inch H ₂ O (in. w.c.)
oz./in ²	1.73	Inch H ₂ O (in. w.c.)
U.S. gal. H ₂ O	8.345	lb

Note: H₂O at 39.2°F / 4°C, Hg at 32°F / 0°C

Flow Rate		
MULTIPLY	BY	TO OBTAIN
Barrel/h, oil	0.935	ft ³ /min.
Barrel/h, oil	42	U.S. gal/h
Barrel/h, oil	0.7	U.S. gal/min.
ft ³ /min.	10.686	Barrel/h, oil
ft ³ /h	0.02832	m ³ /h
Imperial gal/h	1.2009	U.S. gal/h
m ³ /h	35.315	ft ³ /h
m ³ /h	264.2	U.S. gal/h
U.S. gal/h	0.023809	Barrel/h, oil
U.S. gal/min.	1.4286	Barrel/h, oil

Density		
MULTIPLY	BY	TO OBTAIN
kg/m ³	0.06242	lb/ft ³
lb/ft ³	16.019	kg/m ³
lb/in ³	27,681.66	kg/m ³

150 lb. Flanges, ANSI B16.5 Standard

Technical Data

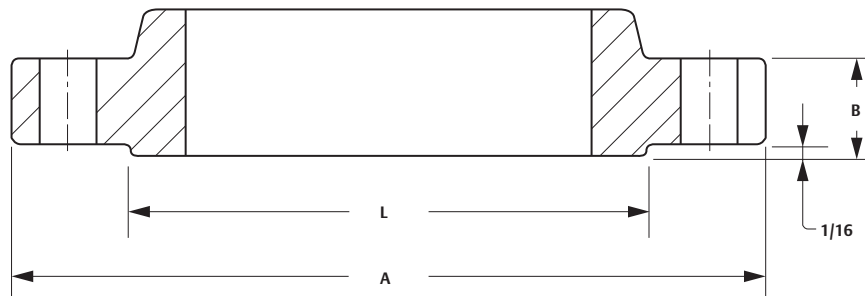

150 lb. Flanges, ANSI B16.5 Standard

NOMINAL PIPE SIZE	A OUTSIDE DIAMETER OF FLANGE	B THICKNESS OF FLANGE	L DIAMETER OF RAISED FACE	DRILLING TEMPLATE			BOLT	
				Number of Holes	Diameter of Holes	Diameter of Bolt Circle	Diameter of Bolt	Machine Bolt Length
In.	In.	In.	In.	In.	In.	In.	In.	In.
1/2	3-1/2	7/16	1-3/8	4	5/8	2-3/8	1/2	1-3/4
3/4	3-7/8	1/2	1-11/16	4	5/8	2-3/4	1/2	2
1	4-1/4	9/16	2	4	5/8	3-1/8	1/2	2
1-1/4	4-5/8	5/8	2-1/2	4	5/8	3-1/2	1/2	2-1/4
1-1/2	5	11/16	2-7/8	4	5/8	3-7/8	1/2	2-1/8
2	6	3/4	3-5/8	4	3/4	4-3/4	5/8	2-3/4
2-1/2	7	7/8	4-1/8	4	3/4	5-1/2	5/8	3
3	7-1/2	15/16	5	4	3/4	6	5/8	3
3-1/2	8-1/2	15/16	5-1/2	8	3/4	7	5/8	3
4	9	15/16	6-3/16	8	3/4	7-1/2	5/8	3
5	10	15/16	7-5/16	8	7/8	8-1/2	3/4	3-1/4
6	11	1	8-1/2	8	7/8	9-1/2	3/4	3-1/4
8	13-1/2	1-1/8	10-5/8	8	7/8	11-3/4	3/4	3-1/2
10	16	1-3/16	12-3/4	12	1	14-1/4	7/8	3-1/4
12	19	1-1/4	15	12	1	17	7/8	4
14	21	1-3/8	16-1/4	12	1-1/8	18-3/4	1	4-1/4
16	23-1/2	1-7/16	18-1/2	16	1-1/8	21-1/4	1	4-1/2
18	25	1-9/16	21	16	1-1/8	22-3/4	1-1/8	4-3/4
20	27-1/2	1-11/16	23	20	1-1/4	25	1-1/8	5-1/4
22 ⁽¹⁾	29-1/2	1-13/16	25-1/4	20	1-3/8	27-1/4	1-1/4	5-1/2
24	32	1-7/8	27-1-1/4	20	1-3/8	29-1/2	1-1/4	5-3/4
26 ⁽¹⁾	34-1/4	2	29-1/4	24	1-3/8	31-3/4	1-1/4	6
28 ⁽¹⁾	36-1/2	2-1/16	31-1/4	28	1-3/8	34	1-1/4	6
30 ⁽¹⁾	38-3/4	2-1/8	33-3/4	28	1-3/8	36	1-1/4	6-3/4
32 ⁽¹⁾	41-3/4	2-1/4	35-3/4	28	1-5/8	38-1/2	1-1/2	6-3/4
34 ⁽¹⁾	43-3/4	2-5/16	37-3/4	32	1-5/8	38-1/2	1-1/2	7
36 ⁽¹⁾	46	2-3/8	40-1/4	32	1-5/8	42-3/4	1-1/2	7

Note: Materials most commonly used: Forged steel SA 181. Available also in stainless steel and non-ferrous metal.

Flanges bored to dimensions shown unless otherwise specified.

1. Flanges for pipe sizes 22, 26, 28, 30, 32, 34 and 36 are not covered by ANSI B16.5.

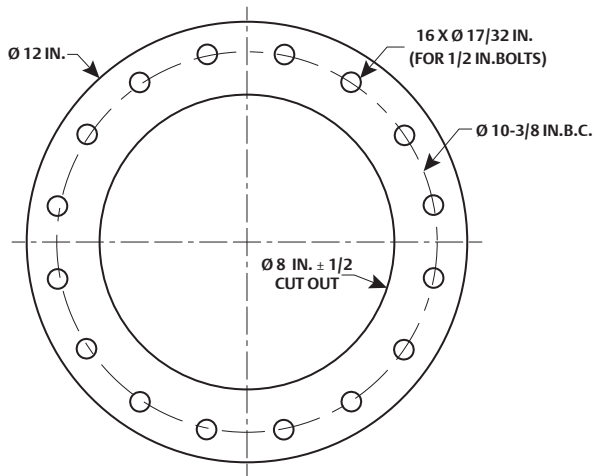

API FLANGE 8 IN. ROUND

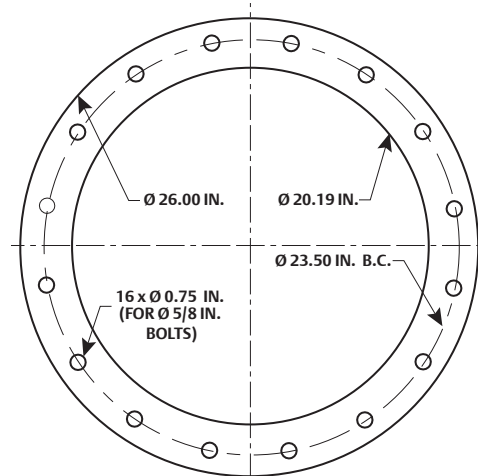

API FLANGE 20 IN. ROUND

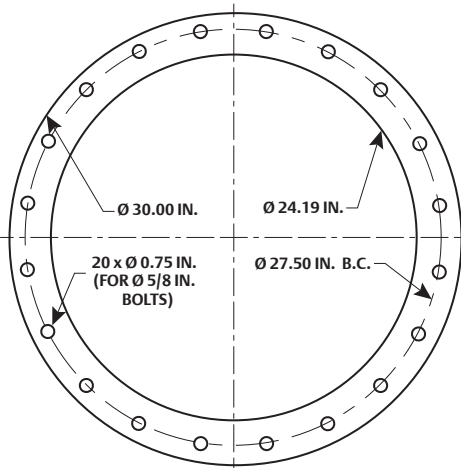

API FLANGE 24 IN. ROUND

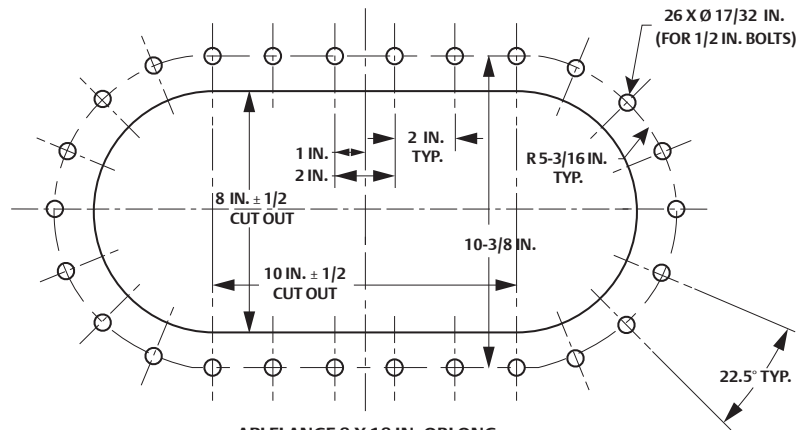

API FLANGE 8 X 18 IN. OBLONG

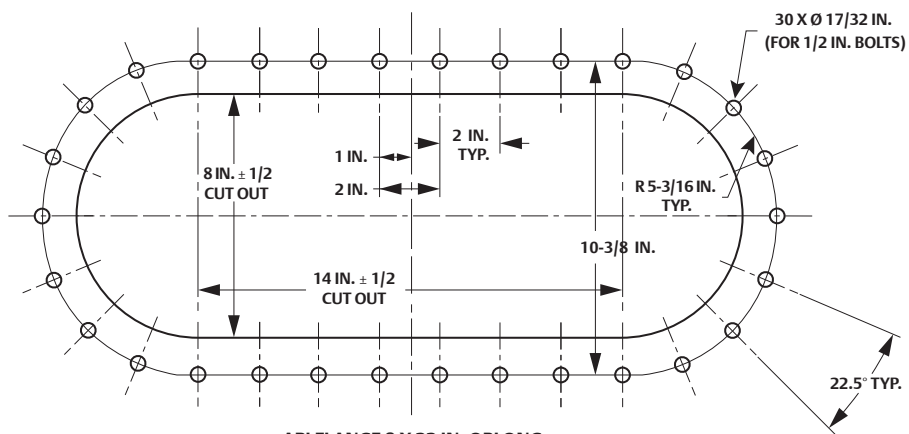

API FLANGE 8 X 22 IN. OBLONG

DIN PN 10 Flanges

Technical Data

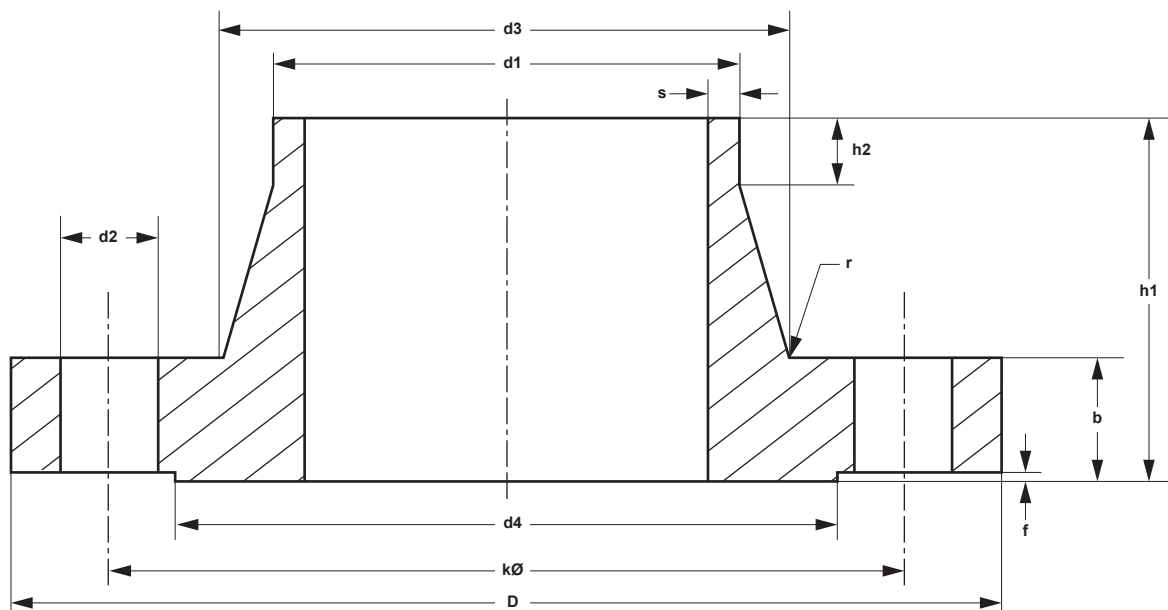

DIN PN 10 Flanges

Nominal Diameter	PAPER SIZE, mm		FLANGE, mm				NECK, mm				RAISED FACE, mm		BOLT			WEIGHT, kg
	ISO Serie 1 Reihe 1	DN Serie 2 Reihe 2	D	b	k	h1	d3	s	r	h2	d4	f	Number of Bolts	Thread	d2, mm	
25	----	30	115	16	85	38	42	2.6	4	6	68	2	4	M12	14	1.14
	33.7	----					45									
32	----	38	140	16	100	40	52	2.6	6	6	78	2	4	M16	18	1.69
	42.4	----					56									
40	----	44.5	150	16	110	42	60	2.6	6	7	88	3	4	M16	18	1.69
	48.3	----					64									
50	----	57	165	18	125	45	72	2.9	6	8	102	3	4	M16	18	2.53
	60.3	----					75									
65	76.1	----	185	18	145	45	90	2.9	6	10	122	3	4	M16	18	3.06
80	88.9	----	200	20	160	50	105	3.2	8	10	138	3	8	M16	18	3.7
100	----	108	220	20	180	52	125	3.6	8	10	158	3	8	M16	18	4.62
	114.3	----					131									
125	----	133	250	22	210	55	150	4	8	10	188	3	8	M16	18	6.3
	139.7	----					156									
150	----	159	285	22	240	55	175	4.5	10	10	212	3	8	M20	22	7.75
	168.3	----					184									
200	219.1	----	340	24	295	62	235	5.9	10	16	268	3	8	M20	22	11.3
250	----	267	395	26	350	68	285	6.3	12	16	320	3	12	M20	22	14.7
	273	----					292									
300	323.9	----	445	26	400	68	344	7.1	12	16	370	4	12	M20	22	17.4
	355.6	----														
350	----	368	505	26	460	68	385	7.1	12	16	430	4	16	M20	22	23.6
	----	----														21.6
400	406.4	----	565	26	515	72	440	7.1	12	16	482	4	18	M24	26	28.6
	----	419														26.2
450	457	----	615	28	565	72	488	7.1	12	16	532	4	20	M24	26	31.5
500	508	----	670	28	620	75	542	7.1	12	16	585	4	20	M24	26	38.1
600	610	----	780	28	725	80	642	7.1	12	16	685	5	20	M27	30	44.6

JIS PN 10K Flanges

Technical Data

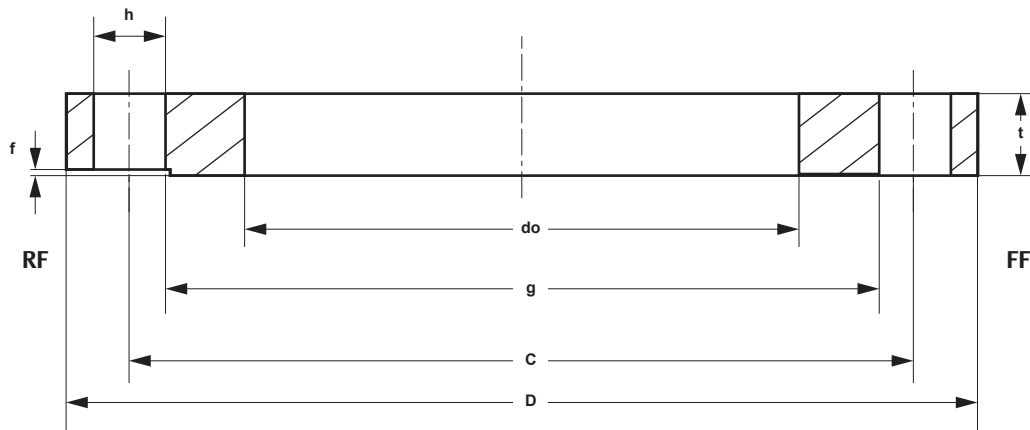

JIS PN 10K Flanges										
PIPE NOMINAL DIAMETER OF FLANGE, mm	PIPE OUTSIDE DIAMETER OF FLANGE D, mm	SECTIONAL DIMENSIONS OF FLANGE								
		Diameter of Bolt Circle C, mm	Diameter of Raised Face g, mm	Inside Diameter of Flange do, mm	Outside Diameter of Applicable Pipe, mm	Raised Face f, mm	t	Hole Diameter h, mm	Number of Bolt Holes Pipe	Nominal Bolt Size Pipe
10	90	65	46	17.8	17.3	1	12	15	4	M12
15	95	70	51	22.2	21.7	1	12	15	4	M12
20	100	75	56	27.7	27.2	1	14	15	4	M12
25	125	90	67	34.5	34.0	1	14	19	4	M16
32	135	100	76	43.2	42.7	2	16	19	4	M16
40	140	105	81	49.1	48.6	2	16	19	4	M16
50	155	120	96	61.1	60.5	2	16	19	4	M16
65	175	140	116	77.1	76.3	2	18	19	4	M16
80	185	150	126	90.0	89.1	2	18	19	8	M16
90	195	160	136	102.6	101.6	2	18	19	8	M16
100	210	175	151	115.4	114.3	2	18	19	8	M16
125	250	210	182	141.2	139.8	2	20	23	8	M20
150	280	240	212	166.6	165.2	2	22	23	8	M20
175	305	265	237	192.1	190.7	2	22	23	12	M20
200	330	290	262	218.0	216.3	2	22	23	12	M20
225	350	310	282	243.7	241.8	2	22	23	12	M20
250	400	355	324	269.5	267.4	2	24	25	12	M22
300	445	400	368	321.0	318.5	3	24	25	16	M22
350	490	445	413	358.1	355.6	3	26	25	16	M22
400	560	510	475	409.0	406.4	3	28	27	16	M24
450	620	565	530	460.0	457.2	3	30	27	20	M24
500	675	620	585	511.0	508.0	3	30	27	20	M24
550	745	680	640	562.0	558.8	3	32	33	20	M30
600	795	730	690	613.0	609.6	3	32	33	24	M30
650	845	780	740	664.0	660.4	3	34	33	24	M30
700	905	840	800	715.0	711.2	3	34	33	24	M30

Conversion Chart Of Pressure and Vacuum Settings

Technical Data

Pressure or Vacuum Setting in Oz./sq. In.				
Oz./sq. in.	mm H ₂ O	kPa	kg/cm ²	mbar
0.5	22.0	0.22	0.0022	2.155
1	43.9	0.43	0.0044	4.309
1.5	65.9	0.65	0.0066	6.464
2	87.9	0.86	0.0088	8.618
2.5	109.9	1.08	0.0110	10.773
3	131.8	1.29	0.0132	12.928
3.5	153.8	1.51	0.0154	15.082
4	175.8	1.72	0.0176	17.237
4.5	197.7	1.94	0.0198	19.392
5	219.7	2.15	0.0220	21.546
5.5	241.7	2.37	0.0242	23.701
6	263.7	2.59	0.0264	25.855
6.5	285.6	2.80	0.0286	28.010
7	307.6	3.02	0.0308	30.165
7.5	329.6	3.23	0.0330	32.319
8	351.5	3.45	0.0352	34.474
8.5	373.5	3.66	0.0374	36.628
9	395.5	3.88	0.0395	38.783
9.5	417.4	4.09	0.0417	40.938
10	439.4	4.31	0.0439	43.092
10.5	461.4	4.52	0.0461	45.247
11	483.4	4.74	0.0483	47.401
11.5	505.3	4.96	0.0505	49.556
12	527.3	5.17	0.0527	51.711
12.5	549.3	5.39	0.0549	53.865
13	571.2	5.60	0.0571	56.020
13.5	593.2	5.82	0.0593	58.175
14	615.2	6.03	0.0615	60.329
14.5	637.2	6.25	0.0637	62.484
15	659.1	6.46	0.0659	64.638
15.5	681.1	6.68	0.0681	66.793
16	703.1	6.89	0.0703	68.948

Pressure or Vacuum Setting in Oz./sq. In. (continued)				
Oz./sq. in.	mm H ₂ O	kPa	kg/cm ²	mbar
16.5	725.0	7.11	0.0725	71.102
17	747.0	7.33	0.0747	73.257
17.5	769.0	7.54	0.0769	75.411
18	791.0	7.76	0.0791	77.566
18.5	812.9	7.97	0.0813	79.721
19	834.9	8.19	0.0835	81.875
19.5	856.9	8.40	0.0857	84.030
20	878.8	8.62	0.0879	86.184
20.5	900.8	8.83	0.0901	88.339
21	922.8	9.05	0.0923	90.494
21.5	944.7	9.26	0.0945	92.648
22	966.7	9.48	0.0967	94.803
22.5	988.7	9.70	0.0989	96.958
23	1010.7	9.91	0.1011	99.112
23.5	1032.6	10.13	0.1033	101.267
24	1054.6	10.34	0.1055	103.421
24.5	1076.6	10.56	0.1077	105.576
25	1098.5	10.77	0.1099	107.731
25.5	1120.5	10.99	0.1121	109.885
26	1142.5	11.20	0.1142	112.040
26.5	1164.5	11.42	0.1164	114.194
27	1186.4	11.63	0.1186	116.349
27.5	1208.4	11.85	0.1208	118.504
28	1230.4	12.07	0.1230	120.658
28.5	1252.3	12.28	0.1252	122.813
29	1274.3	12.50	0.1274	124.967
29.5	1296.3	12.71	0.1296	127.122
30	1318.3	12.93	0.1318	129.277
30.5	1340.2	13.14	0.1340	131.431
31	1362.2	13.36	0.1362	133.586
31.5	1384.2	13.57	0.1384	135.741
32	1406.1	13.79	0.1406	137.895

Conversion Chart Of Pressure and Vacuum Settings

Technical Data

Pressure or Vacuum Setting in In. w.c.				
In. w.c.	mm H ₂ O	kPa	kg/cm ²	mbar
1	25.4	0.25	0.0025	2.491
1.5	38.1	0.37	0.0038	3.736
2	50.8	0.50	0.0051	4.982
2.5	63.5	0.62	0.0064	6.227
3	76.2	0.75	0.0076	7.473
3.5	88.9	0.87	0.0089	8.718
4	101.6	1.00	0.0102	9.964
4.5	114.3	1.12	0.0114	11.209
5	127	1.25	0.0127	12.454
5.5	139.7	1.37	0.0140	13.700
6	152.4	1.49	0.0152	14.945
6.5	165.1	1.62	0.0165	16.191
7	177.8	1.74	0.0178	17.436
7.5	190.5	1.87	0.0191	18.682
8	203.2	1.99	0.0203	19.927
8.5	215.9	2.12	0.0216	21.173
9	228.6	2.24	0.0229	22.418
9.5	241.3	2.37	0.0241	23.663
10	254	2.49	0.0254	24.909
10.5	266.7	2.62	0.0267	26.154
11	279.4	2.74	0.0279	27.400
11.5	292.1	2.86	0.0292	28.645
12	304.8	2.99	0.0305	29.891
12.5	317.5	3.11	0.0318	31.136
13	330.2	3.24	0.0330	32.382
13.5	342.9	3.36	0.0343	33.627
14	355.6	3.49	0.0356	34.872
14.5	368.3	3.61	0.0368	36.118
15	381	3.74	0.0381	37.363
15.5	393.7	3.86	0.0394	38.609
16	406.4	3.99	0.0406	39.854
16.5	419.1	4.11	0.0419	41.100
17	431.8	4.23	0.0432	42.345
17.5	444.5	4.36	0.0445	43.591
18	457.2	4.48	0.0457	44.836
18.5	469.9	4.61	0.0470	46.081
19	482.6	4.73	0.0483	47.327
19.5	495.3	4.86	0.0495	48.572
20	508	4.98	0.0508	49.818
20.5	520.7	5.11	0.0521	51.063
21	533.4	5.23	0.0533	52.309

Pressure or Vacuum Setting in In. w.c. (continued)				
In. w.c.	mm H ₂ O	kPa	kg/cm ²	mbar
21.5	546.1	5.36	0.0546	53.554
22	558.8	5.48	0.0559	54.800
22.5	571.5	5.60	0.0572	56.045
23	584.2	5.73	0.0584	57.290
23.5	596.9	5.85	0.0597	58.536
24	609.6	5.98	0.0610	59.781
24.5	622.3	6.10	0.0622	61.027
25	635	6.23	0.0635	62.272
25.5	647.7	6.35	0.0648	63.518
26	660.4	6.48	0.0660	64.763
26.5	673.1	6.60	0.0673	66.009
27	685.8	6.73	0.0686	67.254
27.5	698.5	6.85	0.0699	68.499
28	711.2	6.97	0.0711	69.745
28.5	723.9	7.10	0.0724	70.990
29	736.6	7.22	0.0737	72.236
29.5	749.3	7.35	0.0749	73.481
30	762	7.47	0.0762	74.727
30.5	774.7	7.60	0.0775	75.972
31	787.4	7.72	0.0787	77.218
31.5	800.1	7.85	0.0800	78.463
32	812.8	7.97	0.0813	79.708
32.5	825.5	8.10	0.0826	80.954
33	838.2	8.22	0.0838	82.199
33.5	850.9	8.34	0.0851	83.445
34	863.6	8.47	0.0864	84.690
34.5	876.3	8.59	0.0876	85.936
35	889	8.72	0.0889	87.181
35.5	901.7	8.84	0.0902	88.427
36	914.4	8.97	0.0914	89.672
36.5	927.1	9.09	0.0927	90.917
37	939.8	9.22	0.0940	92.163
37.5	952.5	9.34	0.0953	93.408
38	965.2	9.47	0.0965	94.654
38.5	977.9	9.59	0.0978	95.899
39	990.6	9.71	0.0991	97.145
39.5	1003.3	9.84	0.1003	98.390
40	1016	9.96	0.1016	99.636
40.5	1028.7	10.09	0.1029	100.881
41	1041.4	10.21	0.1041	102.126
41.5	1054.1	10.34	0.1054	103.372

-continued-

Conversion Chart Of Pressure and Vacuum Settings

Technical Data

Pressure or Vacuum Setting in In. w.c. (continued)				
In. w.c.	mm H ₂ O	kPa	kg/cm ²	mbar
42	1066.8	10.46	0.1067	104.617
42.5	1079.5	10.59	0.1080	105.863
43	1092.2	10.71	0.1092	107.108
43.5	1104.9	10.84	0.1105	108.354
44	1117.6	10.96	0.1118	109.599
44.5	1130.3	11.08	0.1130	110.845
45	1143	11.21	0.1143	112.090
45.5	1155.7	11.33	0.1156	113.335
46	1168.4	11.46	0.1168	114.581
46.5	1181.1	11.58	0.1181	115.826
47	1193.8	11.71	0.1194	117.072
47.5	1206.5	11.83	0.1207	118.317
48	1219.2	11.96	0.1219	119.563
48.5	1231.9	12.08	0.1232	120.808
49	1244.6	12.21	0.1245	122.054
49.5	1257.3	12.33	0.1257	123.299
50	1270	12.45	0.1270	124.544
50.5	1282.7	12.58	0.1283	125.790
51	1295.4	12.70	0.1295	127.035
51.5	1308.1	12.83	0.1308	128.281
52	1320.8	12.95	0.1321	129.526
52.5	1333.5	13.08	0.1334	130.772
53	1346.2	13.20	0.1346	132.017
53.5	1358.9	13.33	0.1359	133.263
54	1371.6	13.45	0.1372	134.508
54.5	1384.3	13.58	0.1384	135.753
55	1397	13.70	0.1397	136.999
55.5	1409.7	13.82	0.1410	138.244

Pressure or Vacuum Setting in psi				
psi	mm H ₂ O	kPa	kg/cm ²	mbar
0.5	351.5	3.45	0.0352	34.474
1	703.1	6.89	0.0703	68.948
1.5	1054.6	10.34	0.1055	103.421
2	1406.1	13.79	0.1406	137.895
2.5	1757.7	17.24	0.1758	172.369
3	2109.2	20.68	0.2109	206.843
3.5	2460.7	24.13	0.2461	241.317
4	2812.3	27.58	0.2812	275.790
4.5	3163.8	31.03	0.3164	310.264
5	3515.3	34.47	0.3515	344.738
5.5	3866.9	37.92	0.3867	379.212
6	4218.4	41.37	0.4218	413.685
6.5	4570.0	44.82	0.4570	448.159
7	4921.5	48.26	0.4921	482.633
7.5	5273.0	51.71	0.5273	517.107
8	5624.6	55.16	0.5625	551.581
8.5	5976.1	58.61	0.5976	586.054
9	6327.6	62.05	0.6328	620.528
9.5	6679.2	65.50	0.6679	655.002
10	7030.7	68.95	0.7031	689.476
10.5	7382.2	72.39	0.7382	723.950
11	7733.8	75.84	0.7734	758.423
11.5	8085.3	79.29	0.8085	792.897
12	8436.8	82.74	0.8437	827.371
12.5	8788.4	86.18	0.8788	861.845
13	9139.9	89.63	0.9140	896.318
13.5	9491.4	93.08	0.9491	930.792
14	9843.0	96.53	0.9843	965.266
14.5	10194.5	99.97	1.0195	999.740
15	10546.0	103.42	1.0546	1034.214



NOTES:

Fully integrated solutions for advancing safety, emissions control and maintaining product integrity.

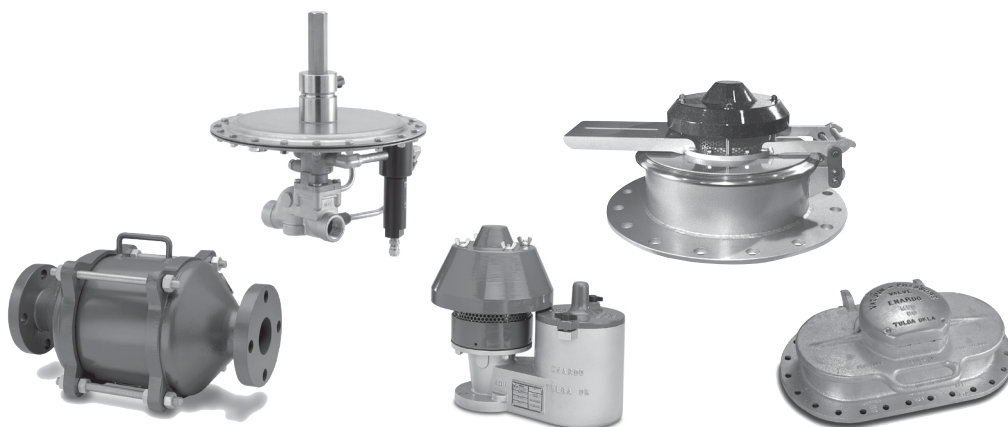

FISHER™ ENARDO™

Achieve optimal safety for your employees, assets and products around the globe with fully integrated solutions from Emerson, your single source for total tank protection.

Emerson

Americas

T +1 800 558 5853
T +1 972 548 3574
Tulsa, OK 74146 USA
T +1 918 662 6161

✉ webadmin.regulators@emerson.com
🔍 [Emerson.com](https://www.emerson.com)
📘 [Facebook.com/EmersonAutomationSolutions](https://www.facebook.com/EmersonAutomationSolutions)
🌐 [LinkedIn.com/company/emerson-automation-solutions](https://www.linkedin.com/company/emerson-automation-solutions)
✂ [X.com/EMR_automation](https://www.x.com/EMR_automation)

Europe

T +39 051 419 0611

Asia Pacific

T +65 6777 8211

Middle East / Africa

T +971 4811 8100

D352441X012 © 2016, 2025 Emerson Process Management Regulator Technologies, Inc. All rights reserved. 05/25.
Enardo™ is a mark owned by Emerson Process Management Regulator Technologies Tulsa, LLC, an Emerson company.
The Emerson logo is a trademark and service mark of Emerson Electric Co. All other marks are property of their respective owners.

