

# Micro Motion™ Corrosion Guide

Coriolis flow meters, density meters, and viscosity meters

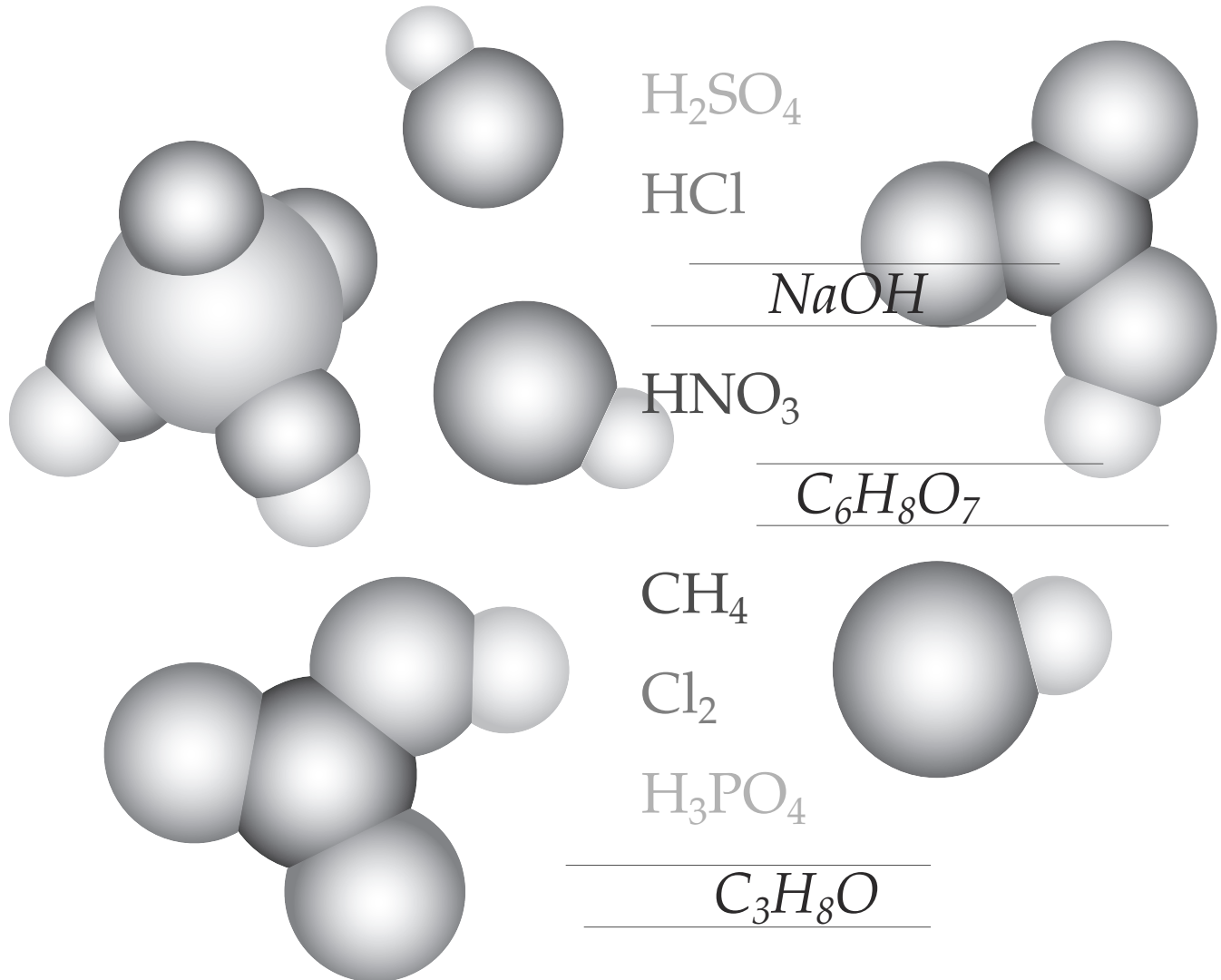

### **Safety and approval information**

This Micro Motion product complies with all applicable European directives when properly installed in accordance with the instructions in this manual. Refer to the EU Declaration of Conformity for directives that apply to this product. The following are available: the EU Declaration of Conformity, with all applicable European directives, and the complete ATEX installation drawings and instructions. In addition, the IECEx installation instructions for installations outside of the European Union and the CSA installation instructions for installations in North America are available at [Emerson.com/global](https://emerson.com/global) or through your local Micro Motion support center.

Information affixed to equipment that complies with the Pressure Equipment Directive, can be found at [Emerson.com/global](https://emerson.com/global). For hazardous installations in Europe, refer to standard EN 60079-14 if national standards do not apply.

### **Other information**

Troubleshooting information can be found in the appropriate Configuration and Use Manual. Product Data Sheets and Manuals are available from the Micro Motion website at [Emerson.com/global](https://emerson.com/global).

### **Return policy**

Follow Emerson procedures when returning equipment. These procedures ensure legal compliance with government transportation agencies and help provide a safe working environment for Emerson employees. If you fail to follow Emerson procedures, then Emerson will not accept your returned equipment.

Return procedures and forms are available on our web support site at [Emerson.com/global](https://emerson.com/global), or by calling the Micro Motion Customer Service department.

### **Emerson Flow customer service**

Email:

- Worldwide: [flow.support@emerson.com](mailto:flow.support@emerson.com)
- Asia-Pacific: [APflow.support@emerson.com](mailto:APflow.support@emerson.com)

# Contents

<b>Chapter 1</b>	<b>Before you begin.....</b>	<b>5</b>
<b>Chapter 2</b>	<b>Meters and corrosion.....</b>	<b>7</b>
	2.1 General corrosion vs. localized corrosion.....	7
	2.2 Coriolis flow and density meters.....	7
	2.3 Fork density and viscosity meters.....	8
	2.4 GDM and SGM density and viscosity meters .....	8
<b>Chapter 3</b>	<b>Chemical compositions and meter compatibility.....</b>	<b>11</b>
	3.1 Halogens.....	11
	3.2 pH.....	12
	3.3 Chemical potential measurements.....	13
<b>Chapter 4</b>	<b>Materials that mitigate corrosion.....</b>	<b>15</b>
	4.1 Super duplex stainless steel.....	15
<b>Chapter 5</b>	<b>Mixed material in meters.....</b>	<b>17</b>
	5.1 Reasons to mix materials.....	17
	5.2 Meter parts and materials.....	17
	5.3 Condensate.....	18
	5.4 Methane, ethane, propane, and ethylene.....	19
	5.5 Nitrogen and argon gases.....	19
	5.6 Natural and petroleum gases.....	19
	5.7 Produced water.....	19
	5.8 Process water.....	19
<b>Chapter 6</b>	<b>Typical chemical applications.....</b>	<b>21</b>
	6.1 Hydrochloric acid .....	21
	6.2 Sodium hydroxide.....	21
	6.3 Nitric acid.....	22
	6.4 Sulfuric acid.....	22
<b>Chapter 7</b>	<b>Material compatibility tables.....</b>	<b>25</b>
	7.1 A chemicals.....	25
	7.2 B chemical tables.....	37
	7.3 C chemical tables.....	41
	7.4 D chemical tables.....	48
	7.5 E chemical tables.....	51
	7.6 F chemical tables.....	54
	7.7 G chemical tables.....	56
	7.8 H chemical tables.....	57
	7.9 I chemical tables.....	60
	7.10 J chemical tables.....	61
	7.11 K chemical tables.....	61
	7.12 L chemical tables.....	62
	7.13 M chemical tables.....	63

7.14 N chemical tables.....	67
7.15 O chemical tables.....	70
7.16 P chemical tables.....	72
7.17 Q chemical tables.....	77
7.18 R chemical tables.....	77
7.19 S chemical tables.....	79
7.20 T chemical tables.....	87
7.21 U chemical tables.....	91
7.22 V chemical tables.....	92
7.23 W chemical tables.....	93
7.24 X chemical tables.....	94
7.25 Y chemical tables.....	94
7.26 Z chemical tables.....	95

# 1 Before you begin

Use this document as a pre sales document to help you select the correct material for Micro Motion meters that measure corrosive chemicals.

The information in this document assumes that users understand all corporate and government safety standards and requirements that guard against injuries and death.

The guidelines in this publication are only for information. Minor changes in fluid properties (for example; temperature, concentration, and impurity levels) can affect the compatibility of wetted parts. Material compatibility choices are solely the responsibility of the end user.



## 2 Meters and corrosion

Choosing the correct meter material requires more consideration than choosing the correct pressure-containing pipe. Material compatibility for a pressure-containing pipe is covered in any general corrosion guide.

### 2.1 General corrosion vs. localized corrosion

#### General corrosion

General corrosion refers to the uniform loss of material. Material loss due to corrosion is expressed in terms of inches or millimeters lost per year. These rates are determined by exposing a sample to the environment for a specific time period. Weight loss or dimensional changes are then used to determine the corrosion rate.

General corrosion tests cannot detect localized corrosion and are inadequate for determining material compatibility for Micro Motion meters.

#### Localized corrosion

Localized corrosion consists of pitting, inter-granular attack, stress corrosion cracking, and corrosion fatigue.

Localized corrosion of the flow tube can initiate fatigue cracking. Meter failure occurs when fatigue cracks propagate rapidly. Avoid the onset of fatigue cracks by selecting the appropriate wetted materials using this guide.

Material compatibility cannot always be assessed by considering the alloys selected for the remainder of the piping system. Material compatibility for most piping systems is based upon general corrosion rates alone and does not account for localized corrosion or cyclic loading. Coriolis meters require vibration of one or two flow tubes to make a mass flow or density measurement. The cyclic loading condition is inherent to all Coriolis meters and must be considered in the material selection process.

### 2.2 Coriolis flow and density meters

Coriolis meters are as reliable in measuring corrosive chemicals as they are in measuring noncorrosive fluids. This reliability requires that corrosive fluids are compatible with the meter construction material.

In order to provide compatible meter construction for every application, Micro Motion manufactures meters in the following materials:

- 316L, 304L, and super duplex stainless steels
- Nickel alloy C22
- Titanium
- Tantalum

Environments	Meter material
Typical	316L stainless steel
Nitric acid	304L stainless steel
Oilfield chlorides and CO <sub>2</sub>	Super duplex stainless steels
Corrosive process fluids	Nickel alloy C22

Environments	Meter material
Chlorides	Titanium
Extreme high temperatures, low PH, or high chloride concentrations	Tantalum

## 2.3 Fork density and viscosity meters

Micro Motion manufactures fork density and viscosity meters in a variety of wetted materials including 316L and 304L stainless steels, nickel alloy C22, titanium, and zirconium.

The specific material compatibility recommendations for fork meters can vary from Coriolis meters. Use the tables specifically for fork meters in the [Material compatibility tables](#).

## 2.4 GDM and SGM density and viscosity meters

Gas Density Meters (GDM) and Gas Specific Gravity Meters (SGM) are not listed in the material compatibility tables. For any implementation questions, contact customer support.

Process gases must be dry (above their dew point), clean, and compatible with all the wetted parts within the meter.

Wetted parts	GDM	SGM
Interior liner <sup>(1)</sup>	17-4PH (UNS-S17400)	416
Pressure housing <sup>(1)</sup>	316L	316L
O-rings <sup>(1)</sup>	Viton (FKM)	•
Reference chamber <sup>(1)</sup>	•	Aluminum alloy
Cylinder <sup>(2)</sup>	Ni-Span-C	Ni-Span-C
Spool body <sup>(2)</sup>	Stycast catalyst 11, Invar/Radiometal	Stycast catalyst 11, Invar/Radiometal
• = Not Applicable.		

(1) Pressure-retaining.

(2) Non-pressure retaining.

Ideal gases include natural gas, hydrogen, methane, propane, etc. Heat may be applied and/or a coalescing filter may be installed in some applications to reduce the presence of liquids that can damage the meters.

For any other gases not falling under the natural gas category, refer to your Emerson representative to determine compatibility.

### SGMs

- Can be used in refinery and fuel gas applications. Fluids with a molecular weight of pentane and higher are generally in liquid form and will have to be removed from the process stream by equipment that removes liquid.
- Are not recommended for use with hydrogen sulfide (H<sub>2</sub>S), except for low concentrations of hydrogen sulfide in which all the water and moisture has been removed.

### **GDMs**

The pressure-containing components of GDM meters are NACE compliant. Low concentrations of hydrogen sulfide (H<sub>2</sub>S) are permitted (less than 1000 ppm), provided the process gas is clean and dry. Install a coalescing filter into the GDM's process line.

### **Hydrogen sulfide wells**

Do neither a GDM nor an SGM in sour gas (hydrogen sulfide-containing) wells.



## 3 Chemical compositions and meter compatibility

The variety of possible meter environments make it difficult to define fluid compatibility for every possible material combination. Nevertheless, you can choose the best material by comparing alloy limitations based on the chemical composition of your fluids. The chemical composition of most environments can be characterized by the following variables:

- Halogen concentration
- pH
- Chemical potential
- Temperature

The following topics show the levels of acceptable performance for 316L stainless steel, nickel alloy C22, titanium, and tantalum. You can characterize the effect of temperature on meter life by considering its effect on the other three variables.

### 3.1 Halogens

*Halogen* refers to a group of elements that includes chlorine, fluorine, bromine, and iodine. The most common halogen is chlorine. The presence of the ionic chloride form,  $Cl^-$ , even as a contaminant, can be detrimental to corrosion resistance. Stainless steels are particularly susceptible in the oxygen-saturated conditions typically found in chemical processing facilities. Meters constructed of 316L stainless steel have been reliable in numerous applications where chloride and oxygen concentrations can be maintained at sufficiently low levels or where free chlorides are absent (see [Figure 3-1](#)). Stainless steel can also be used in organic solutions that contain a chloride component, provided ion formation is avoided. Two factors that influence dissociation are temperature and moisture.

**Figure 3-1: Typical chloride concentration range for meter materials**

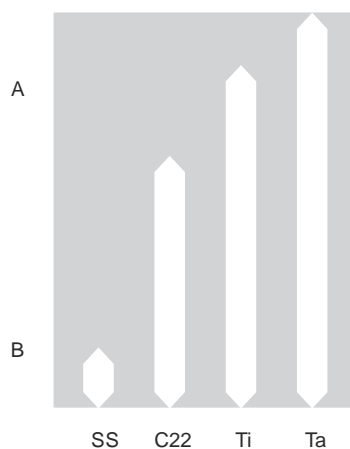

A. High  
B. Low

### Abbreviations

- SS = stainless steel
- C22 = nickel alloy C22
- Ti = titanium
- Ta = tantalum

Temperature and moisture need to be kept low to avoid failure. [Figure 3-2](#) shows that the resistance of 316L to free chloride-induced corrosion fatigue is temperature dependent. Low combinations of temperature and chloride concentration are compatible with 316L stainless steel. Pitting and corrosion fatigue are possible for higher combinations of temperature and chloride concentrations. Nickel alloy C22 should be used when these conditions exist. If the chloride content is increased further and pH lowered, nickel alloy C22 may also succumb to localized attack and corrosion fatigue.

### Note

[Figure 3-2](#) does not apply for produced water and wells. For produced water and well applications, refer to your Emerson representative.

**Figure 3-2: Chloride ion concentrations and temperature limits for 316L under oxygen-saturated conditions**

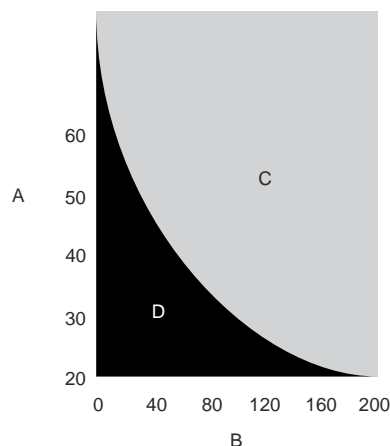

- A. Temperature °C
- B. Chloride (ppm)
- C. Use high nickel-based alloy C22
- D. Use 316L stainless steel

## 3.2

### pH

The pH of a solution can also alter the corrosion of any alloy. In general, solutions that have a neutral pH (near 7) have a slower corrosion rate than strongly acidic (pH < 3) or strongly alkaline (pH > 11) solutions (see [Figure 3-3](#)). Tantalum has superior corrosion resistance to 316L stainless steel and nickel alloy C22 in neutral and acidic environments. However, high corrosion rates will occur if tantalum is used in alkaline caustic applications such as sodium hydroxide, even at room temperature. At higher temperatures, stress corrosion cracking and corrosion fatigue of 316L stainless steel are possible. Under these conditions, nickel alloy C22 is recommended. Use nickel alloy C22 in all caustic applications when there is a possibility of chloride contamination.

Figure 3-3: Typical pH range for meter material

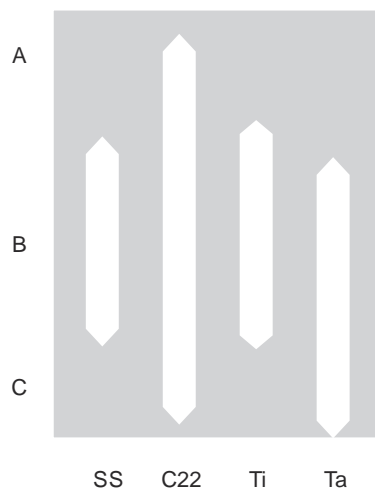

- A. High
- B. Neutral
- C. Low

#### Abbreviations

- SS = stainless steel
- C22 = nickel alloy C22
- Ti = titanium
- Ta = tantalum

### 3.3 Chemical potential measurements

Chemical potential measures the oxidizing or reducing power of a process fluid. Chemical potential, sometimes referred to as *redox potential*, is defined relative to the  $H_2 \rightarrow 2H^+ + 2e^-$  half reaction, which is assigned a value of zero volts. Any environment that has a chemical potential greater than the reference is considered oxidizing. Chemical potentials that are equal to or less than the reference are considered reducing. Chemical potential is important because a minimum amount of oxidizing power is required to enable the formation of protective surface oxide layers. Optimal life will be realized as long as this layer is stable. Environments that are too oxidizing or reducing will prevent stable oxide formation. Under such conditions, failure due to corrosion fatigue or erosion/corrosion is possible.

The corrosion fatigue resistance of a material of construction is related to the range of chemical potentials over which oxide layer stability is maintained. The broader the range in [Figure 3-4](#), the more environments where the material will resist corrosion.

Figure 3-4: Potential chemical range for meter materials

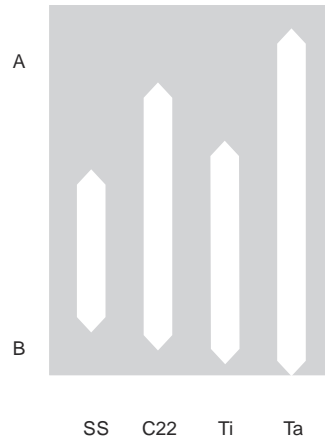

A. Reducing

B. Oxidizing

#### Abbreviations

- SS = stainless steel
- C22 = nickel alloy C22
- Ti = titanium
- Ta = tantalum

Tantalum pentoxide ( $Ta_2O_5$ ) is stable on the surface of metallic tantalum at low reducing potentials. This oxide also resists breakdown in all but the most oxidizing environments.

The wide range of chemical potentials over which passivity is maintained make tantalum resistant to most, but not all, corrosive fluids. Hydrofluoric acid, oleum, and caustics are some of the exceptions that can corrode tantalum. The second most stable oxide forms on the surface of nickel-based alloys, such as nickel alloy C22. A high chromium and molybdenum content stabilizes the oxide layer, yielding improved performance over 316L stainless steel in chloride bearing applications. 316L stainless steel exhibits passivity over a narrow range, as compared to the other two materials. However, 316L stainless steel is suitable for a large number of chemical processing applications.

## 4 Materials that mitigate corrosion

### 4.1 Super duplex stainless steel

For high capacity applications, super duplex stainless steel is an option when a 316L stainless meter is not compatible. Super duplex combines higher strength and better chloride corrosion resistance than 316L, making large meters usable for more demanding conditions. Higher strength allows use at higher operating pressures, and better chloride resistance allows use with higher chloride contents at higher process temperatures.

The oil and gas industry uses super duplex stainless steel in moderate temperature applications containing levels of chlorides and CO<sub>2</sub> too high for 316L stainless. However, sour conditions with elemental sulfur or a H<sub>2</sub>S partial pressure over 3 psia (0.21 bara) can cause corrosion problems. Consider the total process environment when selecting the best construction materials. For recommendations, contact Micro Motion with complete process conditions, including fluid temperature, pressure, bubble point, pH, amounts of chlorides, oxygen, H<sub>2</sub>S, CO<sub>2</sub>, bicarbonates, water, and elemental sulfur.

The wetted components of a super duplex meter that contact the process fluid are made from alloys 2507 and CE3MN (2507 equivalent). Both alloys have a two-phase structure of austenite and ferrite, which is the source of the duplex name. Due to the ferrite content of super duplex, avoid cryogenic applications.



## 5 Mixed material in meters

A meter that consists of two materials is called a *bi-metallic meter*.

### Important

Micro Motion's policy states that when selecting materials for a bi-metallic meter, all materials must meet **all** the recommendations in this guide.

All CMF400P orders are referred to the Micro Motion metallurgy department for alloy approval.

### 5.1 Reasons to mix materials

Typically, bi-metallic meters are used for high-pressure applications.

#### Example 1

The CMF010P sensor has a higher strength nickel alloy C22 tube for high pressure applications and stainless steel process connections that are less compatible with aggressive environments. This option should be used only in environments compatible with stainless steel, the less resilient material.

#### Example 2

For a CMF400P sensor with a 900# SS process connection for a higher pressure rating, use only in environments compatible with stainless steel.

For most applications, nickel alloy C22 has better corrosion resistance than stainless steel. One exception is nitric acid, where 304 stainless steel has better corrosion resistance.

### 5.2 Meter parts and materials

A meter is comprised of three main components that contact the process fluid, known as *wetted components*.

Component	Available in the following material
Tubes	<ul style="list-style-type: none"> <li>316L stainless steel</li> <li>Nickel, chromium, and molybdenum alloy, such as C22</li> </ul>
Manifolds	<ul style="list-style-type: none"> <li>CF-3M (equivalent to 316L stainless steel)</li> <li>CW-2M (equivalent to a nickel, chromium, and molybdenum alloy)</li> </ul>
Process connections and adapters	<ul style="list-style-type: none"> <li>316L stainless steel</li> <li>Nickel, chromium, and molybdenum alloy, such as C22</li> </ul>

316L is a common stainless steel alloy with corrosion resistance to a variety of process fluids. C22 is more resistant to Chloride-induced Stress Corrosion Cracking (CSCC).

The following figure shows the inside of a CMF400P sensor where the tubes are made from C22 for high pressure applications. The process connections are made from 900# stainless steel for a higher pressure rating. Use this option only for environments that are compatible with the process connection material (316L), the least resilient material.

**Figure 5-1: CMF400P with flow tubes highlighted**

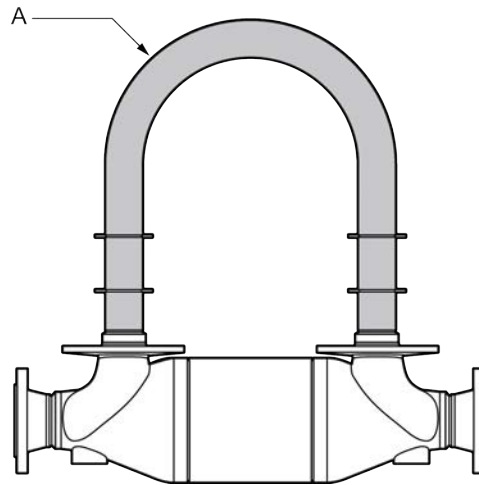

A. C22 flow tubes

The following figure shows the inside of a CMF010P sensor where the tubes are made from C22 for high pressure applications. The process connections are made from 900# stainless steel for a higher pressure rating. This option should be used only for environments that are compatible with the process connection material (316L), the least resilient material.

**Figure 5-2: CMF010P tubes and process connections**

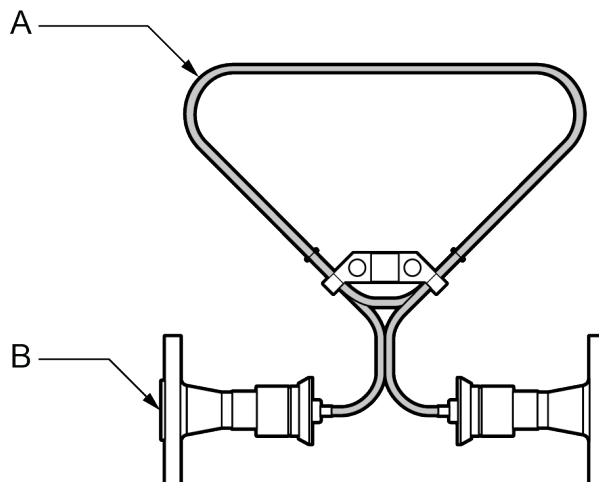

A. C22 flow tubes  
B. Process connection

## 5.3 Condensate

Water-free petroleum condensates are not corrosive when temperatures are below the threshold for hydrocarbon cracking. Hydrocarbon cracking occurs during refining at extreme high temperatures.  $H_2S$  contained in these hydrocarbons do not attack steel at  $< 900\text{ }^\circ\text{F}$  ( $482\text{ }^\circ\text{C}$ ), as long as water is not present. For 316L and nickel alloy C22, corrosion from  $H_2S$  without water does not occur until temperatures exceed  $900\text{ }^\circ\text{F}$  ( $482\text{ }^\circ\text{C}$ ).

However, when water is present, pH, chloride content, water cut, H<sub>2</sub>S, CO<sub>2</sub>, dissolved oxygen content, pressure, and temperature can cause corrosion, pitting, and stress corrosion cracking (SCC) of 316L. See [Produced water](#).

## 5.4 Methane, ethane, propane, and ethylene

These hydrocarbons are non-corrosive to stainless steels and nickel alloys, even when water is present (such as condensed fresh water).

## 5.5 Nitrogen and argon gases

Nitrogen and argon gases are non-corrosive to stainless steels and nickel alloys and can be used up to the temperature limits of the meter.

## 5.6 Natural and petroleum gases

Liquid Natural Gas (LNG) and Liquid Petroleum Gas (LPG) are non-corrosive. One exception is the fracture toughness of the CF-3M alloy manifold. Since CF-3M contains ferrite, the fracture toughness at -260 °F (-162 °C) LNG temperatures may not be adequate. For LNG applications, C22 is the best choice for low temperature impact toughness.

## 5.7 Produced water

Produced water contains numerous possible compositions of oil and gas. The composition depends on reservoir conditions, the formation water chemistry, and the amount of H<sub>2</sub>S and CO<sub>2</sub> in the reservoir. Moreover, these conditions can change over time due to water or CO<sub>2</sub> flooding, or if any enhanced oil recovery methods are applied.

For oil field operations that are less than 400 °F (204 °C), there are no restrictions or limits for nickel alloy C22, even in the presence of H<sub>2</sub>S.

However, carefully consider the chemical environment and process conditions before using a stainless steel or bi-metallic meter.

## 5.8 Process water

As with produced water, there are multiple possible compositions of process water. Process water can be sea water with a high chloride content, from the city tap with a low chloride content, or from distilled water without chlorides.



## 6 Typical chemical applications

### 6.1 Hydrochloric acid

Hydrochloric acid (HCl) in the 1-37% concentration range acts as a reducing agent.

Hydrochloric acid causes severe corrosion due to strong acids combined with chlorine. Tantalum and zirconium are the few materials resistant to hydrochloric acid's corrosive nature.

Avoid nickel alloy C22 meters with medium to high acid concentrations and at high temperatures, due to loss of passivity and corrosion in the active state. Tantalum is a better choice in these circumstances.

A zirconium FDM, which is generally compatible with pure hydrochloric acid and water, is susceptible to corrosion in certain applications containing oxidizing impurities, such as ferric ions ( $\text{Fe}^{+3}$ ) and cupric ions ( $\text{Cu}^{+2}$ ). Zirconium can succumb to pitting and intergranular corrosion when these impurities are present in hydrochloric acid solutions. Oxidizing ions can be in the source acid, or they could enter the stream from corrosion of other components in the system. The material compatibility tables attempt to address these concerns where possible, but use care selecting meter material when oxidizing impurities are known to be present in an application.

### 6.2 Sodium hydroxide

Sodium hydroxide (NaOH) is used to control pH or as a cleaning compound. Due to advanced production methods, stainless steel can be an appropriate material for sodium hydroxide. Nevertheless, stress corrosion cracking can occur at high temperatures. If stress corrosion cracking occurs, corrosion fatigue is also possible depending upon the stress state resulting from the applied loads. Since sodium hydroxide is often mixed with water containing chlorine, the chlorine may have a greater effect on meter life than the concentration or temperature of the sodium hydroxide alone.

#### Sodium hydroxide with and without chloride ion ( $\text{Cl}^-$ )

Experiments were conducted using a 50% sodium hydroxide solution that was compared to a 50% sodium hydroxide solution with an additional 2.5% ( $\text{Cl}^-$ ). Electrochemical and corrosion fatigue data were collected on 316L samples exposed to these solutions. After 4 months of exposure to the solution **without** the chloride ion, there was no failure of stainless steel meters. Metallographic analysis showed no indication of stress corrosion cracking or localized corrosion. A second group of meters exposed to solutions containing the chloride ion showed corrosion fatigue after 4 days of exposure. The temperature in all cases was 200 °F (93 °C). Electrochemical tests in these environments indicated the presence of an oxide layer on 316L surfaces. The passive current density, which is an inverse measure of oxide layer thickness, was 25 times higher when the chloride ion was present. The higher current density indicates that the chloride ion will substantially thin the oxide layer, resulting in a higher susceptibility to mechanical damage. This in turn explains the dramatically lower life shown in corrosion fatigue tests.

#### High concentrations of sodium hydroxide and high temperatures

Stress corrosion cracking, or corrosion fatigue, is not expected in stainless steel meters exposed to pure sodium hydroxide solutions where the concentration is less than 50% by weight and the temperature is 200 °F (93 °C) or lower. Higher concentrations, and especially higher temperatures, could cause failure. Nickel alloy C22 is recommended under these conditions. The presence of the chloride ion can be detrimental to 316L

stainless steel meter life. If the presence of chlorine is possible, use nickel alloy C22 over stainless steel. However, despite having better resistance than 316L, use of Nickel alloy C22 on Sodium hydroxide at higher concentrations and temperatures can still pose corrosion risks and should still be taken on a case-by-case basis. Consult your Emerson representative for guidance.

#### Sodium hydroxide in cleaning compounds

Sodium hydroxide is also used as the alkaline component in many standard clean-in-place (CIP) solutions. These solutions are typical in food and beverage industries and in the life sciences industry. These solutions are flushed through the meter for varying periods of time and at elevated temperatures. In general, these solutions have been designed and successfully used in process streams constructed with stainless steel (316L or 304L). The use of titanium in the aforementioned industries has raised concerns regarding compatibility. In many cases, titanium is more corrosion resistant than stainless steel. However, in strong bases where the protective oxide film has a difficult time regenerating, the titanium can be more susceptible to uniform attacks involving the entire tube.

---

#### Important

Consider all potential process fluids passing through a meter when assessing materials.

---

## 6.3 Nitric acid

Since nitric acid ( $\text{HNO}_3$ ) is a strong oxidizing acid, use alloys that form stable adhering oxide films. In general, high chromium-containing alloys and strong passivating metals like tantalum are the most resistant.

The most commonly-used material for nitric acid is 304L stainless steel. The corrosion resistance of 304L is slightly better than 316L, which contains molybdenum.

Corrosion rates increase with higher temperatures and concentrations. Intergranular corrosion can occur when stainless steel or nickel alloys are sensitized, which means they contain precipitated carbides. Low carbon grades like 316L and 304L are normally not susceptible to intergranular corrosion.

However, intergranular corrosion can also occur regardless of heat treatment or composition of the alloy if hexavalent chromium ions are allowed to accumulate in the acid to some critical concentration. Chromium ion contamination can be in the source acid, or can enter the process stream from the corrosion of stainless steel tanks and pipes.

Titanium is not compatible with red fuming nitric acid at any temperature.

## 6.4 Sulfuric acid

Selecting the best material for sulfuric acid applications can be difficult. Applications that appear to be similar can have drastically different electrochemical properties. For newer applications, or applications where the risk of fluid release is to be minimized, Micro Motion ELITE™ meters have excellent turndown characteristics that you can size to reduce fluid velocity in the sensor.

316L stainless steel meters are best suited for low temperatures at both low and high concentrations of sulfuric acid. Use nickel-based alloy meters for slightly higher temperatures and for broader concentration ranges.

316L stainless steel and nickel-based alloys depend on electrochemical passivity for resistance to corrosion in sulfuric acid. Electrochemical passivity refers to the state of the material's protective oxide layer. The material's protective oxide layer exists in one of following states:

- Passive** The oxide layer is highly stable and provides the material's excellent corrosion resistance.
- Active** The oxide layer is not stable or protective. The base metal can be exposed, allowing corrosion to occur.
- Transpassive** The transpassive state is similar to the active state in that the oxide layer is less stable.

To maximize meter life, maintain the oxide layer in the passive state. However, exposure to sulfuric acid under varying conditions can cause the passive or stable oxide layer to become active or less stable.

When making the decision to place a 316L stainless steel or nickel-based alloy meter in a sulfuric acid application, consider all of the following factors. Each of the following factors can impact the stability of the protective oxide layer.

### Concentration

Sulfuric acid can be oxidizing and not aggressively corrosive at diluted concentrations up to about 10–15%. As concentration increases into the intermediate range, sulfuric acid becomes reducing and considerably more aggressive. Micro Motion does not recommend 316L stainless steel in the intermediate concentration ranges of sulfuric acid. However, nickel alloy C22 is more resistant in mildly reducing environments, and are more applicable in the intermediate concentration range. High acid concentrations are more oxidizing, and less likely to attack the protective oxide layer as concentration increases.

### Temperature

The temperature of the process stream affects the stability of the oxide layer. As temperature increases, the margin between an active and passive oxide layer lessens. For any sulfuric acid application, lowering the temperature enhances the stability of the oxide layer.

### Velocity

There are no erosive constituents in most sulfuric acid process streams. Yet, sulfuric acid can still erode pipes. Sulfuric acid in the intermediate and higher concentration range can cause unexpected oscillations in the oxide layer from passive to active, and then back to passive (and so on).

When the oxide layer is in the less stable active state, the acid can pull the layer into the process stream before it can make the transition back to the more stable passive state. This forms a passive layer that becomes active and then gets stripped. Another passive layer forms and the cycle repeats, causing erosion.

Reducing the fluid velocity can lessen the likelihood of the active oxide layer eroding from the material surface. The compatibility tables include general guidelines for maximum fluid velocity at different concentrations and temperatures. The velocity recommendations apply to only 316L stainless steel and C22 nickel. Tantalum is less affected by acid velocity.

Velocity recommendations primarily came from data for 316L stainless steel. However, nickel-based alloy implementations could also benefit from these recommendations. Based on the corrosiveness of sulfuric acid in the 75%–90% range, maintain fluid velocity as low as possible.

### Stabilizing factors

Aeration of the sulfuric acid solution can stabilize the passive oxide layer in both 316L stainless steel and nickel-based alloys.

Oxidizing impurities such as Fe<sup>+++</sup> (ferric), Cu<sup>++</sup> (cupric), Sn<sup>++++</sup> (stannic), or Ce<sup>++++</sup> (cerric) ions in the process stream stabilize the passive film. In concentrations of sulfuric

acid above 97%,  $\text{SO}_3$  (sulfite) can also stabilize the passive film; however, halides in sulfuric acid (such as chlorides) can have a detrimental effect on the stability of the oxide layer.

# 7 Material compatibility tables

## Chemicals

Chemicals are listed alphabetically under the appropriate chemical names, not under trade names. Trade names and other commonly-used names are listed in the synonym tables with a yellow background. Consider all fluids and flow conditions when selecting material. This includes the primary fluid, contaminants, cleaning, and/or other chemical solutions.

## Temperature and concentration

Consider each chemical's various temperature and concentration combinations when choosing material.

In general, lower chemical temperatures reduce the possibility of localized corrosion.

Both high and low chemical concentrations can cause corrosion. Low chemical concentrations can cause corrosion due to fluid evaporation. Avoid this situation by keeping the meter full at all times. To empty the meter, completely flush the meter of any residual corrosive.

## Material compatibility table legend

- X** Material is not compatible
- O** Material is compatible
- No data is available
- C** Conflicting data

## Note

Corrosion data is not always available for the full temperature range of the meter. Materials typically maintain corrosion resistance at temperatures below the lower limits in the table. Contact Micro Motion if your process might exceed the maximum temperature limits listed here. Where temperature ranges have been omitted from the tables, corrosion resistance is believed to be maintained throughout the temperature range of the meter. For applications that do not appear in this corrosion guide, contact Micro Motion.

## Material codes

The material tables have columns that contain the following codes:

<b>304L</b>	304L stainless steel	<b>Ta</b>	Tantalum
<b>316L</b>	316L stainless steel	<b>Ti</b>	Titanium (grade 2 for fork meters)
<b>C22</b>	Nickel alloy C22	<b>Zr</b>	Zirconium grade 702
<b>SS</b>	Stainless steel		

## 7.1 A chemicals

Table 7-1: Synonyms for A chemicals

Synonym	Listed under
Acetic aldehyde	Acetaldehyde
Acetic ether	Ethyl acetate

**Table 7-1: Synonyms for A chemicals (continued)**

Synonym	Listed under
Acetic oxide	Acetic anhydride
Acetic oxide, acetyl oxide	Acetic anhydride
Acetylaldehyde	Acetaldehyde
Acetylchloride	Acetyl chloride
Acetyl oxide	Acetic anhydride
Acryl amide	Acrylamide
Actylene tetrachloride	Tetrachloroethane
Albone	Hydrogen peroxide
Allylic alcohol	Allyl alcohol
Amino benzene	Aniline
Ammonium hydroxide	Ammonia
Ar	Argon
Azine	Pyridine
Aziotic acid	Nitric acid

### 7.1.1 A chemicals with Coriolis meters

Chemical	Temp °C		Conc. % wt		SS	C22	Ta	Ti
	Low	High	Low	High				
Acetaldehyde	-18	93	0	100	O	O	X	O
	93	149	0	100	—	—	—	O
Acetate	-18	52	0	100	O	O	—	O
	52	77	0	100	O	O	—	O
	77	100	0	100	O	O	—	O
	100	204	0	100	O	O	—	O
Acetic acid	-18	10	0	50	O	O	O	O
	-18	10	50	80	O	O	O	O
	-18	10	80	95	—	O	O	O
	-18	10	95	100	O	O	O	O
	10	38	0	100	O	O	O	O
	38	71	0	50	O	O	O	O
	38	71	50	80	O	O	O	O
	38	71	80	95	X	O	O	O
	38	66	95	100	O	O	O	O
	66	93	95	100	O	O	O	O
	71	79	0	45	O	O	O	O
	71	79	45	50	C	O	O	O

Chemical	Temp °C		Conc. % wt		SS	C22	Ta	Ti
	Low	High	Low	High				
	71	79	50	80	—	O	O	O
	79	93	0	45	O	O	O	O
	79	93	45	50	C	O	O	O
	79	93	50	55	—	O	O	O
	79	93	55	95	X	O	O	O
	93	99	0	20	O	O	O	O
	93	99	20	50	C	O	O	O
	93	99	50	55	—	O	O	O
	93	99	55	80	X	O	O	O
	93	99	80	95	X	O	O	—
	93	118	95	100	X	O	O	X
	99	104	0	20	O	O	O	O
	99	104	20	50	C	O	O	O
	99	104	50	55	—	O	O	O
	99	104	55	80	X	O	O	O
	99	104	80	95	X	O	O	—
	104	127	0	20	O	O	O	O
	104	127	20	50	C	O	O	O
	104	127	50	55	—	O	O	O
	104	127	50	80	X	X	O	O
	104	127	80	85	X	X	O	—
	104	127	85	95	X	X	O	X
	118	204	95	100	X	O	O	X
	127	135	0	20	O	O	O	—
	127	135	20	50	C	X	O	—
	127	135	50	55	—	X	O	—
	127	135	50	85	X	X	O	—
	127	135	85	95	X	X	O	X
	135	149	0	20	O	O	O	X
	135	149	20	50	C	X	O	X
	135	149	50	55	—	X	O	X
	135	149	55	95	X	X	O	X
	149	204	0	20	O	—	O	X
	149	204	20	50	C	X	O	X
	149	204	50	55	—	X	O	X
	149	204	55	95	X	X	O	X

Chemical	Temp °C		Conc. % wt		SS	C22	Ta	Ti
	Low	High	Low	High				
Acetic anhydride	-18	38	0	100	X	O	O	O
	38	121	0	100	X	O	X	O
	121	143	0	100	X	O	X	O
Acetone	-18	60	0	100	O	O	O	O
	60	93	0	100	O	O	O	O
	93	104	0	100	O	O	O	—
	104	149	0	100	O	—	O	—
	149	204	0	100	O	—	—	—
Acetone cyanohydrin					O	—	O	—
Acetonitrile	0	50	0	100	O	X	O	X
Acetyl chloride	-18	21	0	100	X	O	O	—
	21	37	0	100	X	O	—	—
	37	60	0	100	X	—	—	—
Acetylene	0	26	0	100	O	O	O	O
	26	37	0	100	O	O	—	—
	37	116	0	100	O	—	—	—
	116	204	0	100	O	—	—	—
Acetylene tetrabromide					X	—	O	—
Acetylene trichloride	0	106	0	90	X	O	O	—
Acid pulping	0	80	0	100	X	O	O	—
Acid soluble oil					X	X	X	X
Acrylamide	0	40			O	O	—	—
Acrylic acid	0	53			O	O	—	—
Acrylic emulsion					O	O	O	—
Acrylonitrile	0	60	0	100	O	O	O	O
	60	87	0	100	O	O	O	O
	87	104	0	100	X	O	O	X
	104	130	0	100	—	—	O	X
Adipic acid	0	10	0	100	O	O	O	O
	10	93	0	100	O	O	X	O
	93	120	0	100	C	C	X	O
	120	134	0	100	C	C	X	O
	134	220	0	100	X	—	—	O
Air					O	O	O	O
Alachlor technical; chlorodiethylacetanilide					—	O	O	—

Chemical	Temp °C		Conc. % wt		SS	C22	Ta	Ti
	Low	High	Low	High				
Alcohols	0	100	0	100	O	O	O	C
Alimet Feed Additive					X	—	O	—
Alkylbenzene sulfonic acid					X	O <sup>(1)</sup>	O	X
Alkyldimethyl ammonium chloride					X	O	O	—
Alkylsulfonic acid					X	O <sup>(1)</sup>	O	X
Allyl alcohol	0	93	0	100	O	O	X	X
	93	209	0	100	O	X	—	—
Allyl chloride	0	26	0	100	C	O	—	O
	26	82	0	100	X	X	—	O
Allyl chloride phenol					X	O	O	O
Allyl chloroformate (anhydrous)					X	O	O	—
Allyl phenol	0	130	0	100	O	—	—	—
Allylbenzene	20	60	0	100	O	—	—	—
Alpha-methylstyrene					O	O	O	—
Alum	0	30	0	100	O	O	X	O
	30	98	0	100	—	X	—	O
	98	120	0	100	—	—	—	—
Alumina					O	O	O	O
Aluminum chloride aqueous	0	93	0	10	X	O	O	O
	0	93	10	100	X	O	O	X
	93	120	0	100	X	X	O	X
Aluminum chloride dry	0	93	0	100	X	O	O	X
	93	120	0	100	X	—	O	—
Aluminum chlorohydrate					X	O	O	—
Aluminum chlorohydroxide					X	O	O	—
Aluminum fluorosulfate	0	200	0	15	—	O	O	—
Aluminum nitrate	0	98	0	100	O	C	O	O
	98	120	0	100	X	—	O	—
Aluminum oxide					O	O	O	O
Aluminum silicate					—	—	—	—
Aluminum sulfate	0	38	0	100	X	O	O	O
	38	93	0	100	X	—	O	O
Amine oxide					O	O	—	—

Chemical	Temp °C		Conc. % wt		SS	C22	Ta	Ti
	Low	High	Low	High				
Ammonia	-35	0	0	50	O	O	X	C
	0	30	0	50	O	O	X	O
	30	70	0	30	O	O	X	X
	30	70	30	50	X	O	X	X
	70	130	0	50	X	O	X	X
Ammonia anhydrous					O	O	X	X
Ammonium bifluoride	10	120	0	100	X	X	X	X
Ammonium bisulfate	0	38	0	60	X	C	—	O
Ammonium bisulfite	0	60	0	30	X	C	—	O
Ammonium carbamate	80	120	0	65	C	C	O	X
Ammonium carbonate	0	20	0	30	O	O	O	O
	20	93	0	30	O	X	O	O
	93	120	0	30	X	—	—	—
Ammonium chloride	0	93	0	10	X	O	O	O
	0	82	0	50	X	O	O	O
	82	104	0	50	X	—	O	O
	104	120	0	50	X	—	—	—
Ammonium dihydrozene phosphate					—	O	O	—
Ammonium hydroxide	0	30	0	50	O	O	O	O
	30	70	0	30	O	O	X	X
	30	70	30	50	X	O	X	X
	70	150	0	50	X	O	X	X
Ammonium laurate					O	—	—	—
Ammonium laureth sulfate					—	O	O	—
Ammonium nitrate	0	93	0	100	C <sup>(2)</sup>	O	O	O
	93	120	0	100	X <sup>(2)</sup>	C	—	O
Ammonium oxalate	0	24	0	10	X	O	O	—
Ammonium persulfate	0	25	0	5	O	O	O	O
	0	25	5	10	O	O	—	O
	0	60	10	100	O	—	—	O
	60	120	10	100	—	—	—	—

Chemical	Temp °C		Conc. % wt		SS	C22	Ta	Ti
	Low	High	Low	High				
Ammonium phosphate	0	60	0	10	O	O	O	O
	0	60	10	100	X	O	O	O
	60	104	0	10	X	X	O	O
	60	120	10	100	—	—	O	—
	104	120	0	10	—	—	O	—
	120	148	10	100	—	—	O	—
Ammonium saltwater	20	80	0	15	X	O	X	—
Ammonium sulfate	0	104	0	10	X	O	O	O
	0	120	10	100	X	X	O	O
	104	120	0	10	X	X	O	—
	120	160	0	10	X	X	O	—
	120	149	10	100	X	X	O	—
Ammonium sulfide	0	70	0	100	—	O	O	—
Ammonium thioglycolate					O	O	—	—
Ammonium thiosulfate					—	O	—	O
Amyl chloride	0	60	0	100	O	O	O	X
	60	120	0	100	—	—	O	—
	120	148	0	100	—	—	O	—
Amyl mercaptan	0	160	0	100	—	O	O	—
Amylphenol	0	200	0	100	—	O	O	—
Aniline	0	110	0	100	O	O	O	O
	110	120	0	100	O	O	—	—
	120	265	0	100	O	—	—	—
Animal fat					—	O	—	O
Anodizing solution aluminum					—	O	O	—
Anthracene oil	80	90	0	100	O	—	—	—
Anthraquinone					—	—	—	—
Antibiotic fermentation media					—	O	O	—
Anti-static agent 743					X	O	—	—
Antimony pentachloride	0	71	0	50	X	O	O	—
Apple juice					O	O	O	O
Aqua quinine					O	O	—	—
Aqua regia	0	20	0	75	X	X	O	O
	20	82	0	75	X	X	O	—

Chemical	Temp °C		Conc. % wt		SS	C22	Ta	Ti
	Low	High	Low	High				
Argon					O	O	O	O
Arsenic acid	0	65	0	100	O	X	—	—
	65	120	0	100	X	X	—	—
Asphalt	0	60	0	100	O	O	—	O
	60	200	0	100	O	O	O	O
Atropine	0	60	0	100	—	O	—	—

- (1) Maintain velocity < 10 ft/sec (3 m/sec).  
(2) 304L = O

## 7.1.2 A chemicals with fork density and viscosity meters

Chemical	Temp °C		Conc. % wt		316L	304L	C22	Ti	Zr
	Low	High	Low	High					
Acetaldehyde	-18	93	0	100	O	—	O	O	—
	93	120	0	100	—	—	—	O	O
Acetate	-18	52	0	100	O	—	O	O	O
	52	77	0	100	O	—	O	O	O
	77	100	0	100	O	—	O	O	O
	100	204	0	100	O	—	O	O	—
Acetic acid <sup>(1)</sup>	-18	10	0	50	O	—	O	O	O
	-18	10	50	80	O	—	O	O	O
	-18	10	80	95	—	—	O	O	O
	-18	10	95	100	O	—	O	O	O
	10	38	0	100	O	C	O	O	O
	38	71	0	50	O	—	O	O	O
	38	71	50	80	O	—	O	O	O
	38	71	80	95	O	—	O	O	O
	38	66	95	100	O	C	O	O	O
	66	93	95	100	O	C	O	O	O
	71	79	0	45	O	C	O	O	O
	71	79	45	50	C	C	O	O	O
	71	79	50	80	C	C	O	O	O
	79	93	0	45	O	C	O	O	O
	79	93	45	50	C	C	O	O	O
	79	93	50	55	—	C	O	O	O
79	93	55	95	X	X	O	O	O	
93	99	0	20	O	—	O	O	O	

Chemical	Temp °C		Conc. % wt		316L	304L	C22	Ti	Zr
	Low	High	Low	High					
	93	99	20	50	C	C	O	O	O
	93	99	50	55	—	C	O	O	O
	93	99	55	80	X	X	O	O	O
	93	99	80	95	X	X	O	O	O
	93	118	95	100	X	X	O	X	O
	99	104	0	20	O	—	O	O	O
	99	104	20	50	C	C	O	O	O
	99	104	50	55	—	C	O	O	O
	99	104	55	80	X	X	O	O	O
	99	104	80	95	X	X	O	—	O
	104	127	0	20	O	X	O	O	O
	104	127	20	50	C	X	O	O	O
	104	127	50	55	—	C	O	O	O
	104	127	50	80	X	X	O	O	O
	104	127	80	85	X	X	O	O	O
	104	127	85	95	X	X	O	X	O
	118	204	95	100	O	X	O	X	—
	127	135	0	20	O	X	O	X	O
	127	135	20	50	O	X	X	X	O
	127	135	50	55	O	X	X	X	O
	127	135	50	85	C	X	X	X	O
	127	135	85	95	C	X	X	X	O
	135	149	0	20	O	X	O	X	O
	135	149	20	50	O	X	X	X	O
	135	149	50	55	O	X	X	X	O
	135	149	55	95	C	X	X	X	O
	149	204	0	20	O	X	X	—	—
	149	204	20	50	O	X	X	—	—
	149	204	50	55	O	X	X	—	—
	149	204	55	95	C	X	X	—	—
Acetic anhydride	-18	38	0	100	C	—	O	O	O
	38	121	0	100	C	—	O	O	—
	121	143	0	100	C	—	O	O	—
Acetone	-18	60	0	100	O	—	O	O	O
	60	93	0	100	O	—	O	O	O
	93	104	0	100	O	—	O	O	O

Chemical	Temp °C		Conc. % wt		316L	304L	C22	Ti	Zr
	Low	High	Low	High					
	104	149	0	100	O	—	—	—	—
	149	204	0	100	O	—	—	—	—
Acetone cyanohydrin					O	—	—	—	—
Acetonitrile	0	60	0	100	O	—	X	X	—
Acetyl chloride	-18	21	0	100	X	—	O	—	—
	21	37	0	100	X	—	O	—	—
Acetylene	0	26	0	100	O	—	O	—	—
	26	37	0	100	O	—	O	—	—
	37	116	0	100	O	—	O	—	—
	116	204	0	100	O	—	O	—	—
Acetylene tetrabromide					X	X	O	—	—
Acetylene trichloride (dry)					O	X	O	—	—
Acid pulping	0	80	0	100	—	—	O	—	—
Acrylic acid	0	53			O	—	O	—	—
Acrylic emulsion					O	—	O	—	—
Acrylonitrile	0	60	0	100	O	—	O	O	O
	60	87	0	100	O	—	O	O	O
	87	104	0	100	—	—	O	—	O
	104	130	0	100	X	X	—	X	O
Adipic acid	0	10	0	100	O	—	O	O	—
	10	93	0	100	O	—	O	O	—
	93	120	0	100	—	—	—	O	—
	120	220	0	100	—	—	—	O	—
Alachlor technical; chlorodiethylacetanilide					X	X	O	—	—
Alcohols	0	100	0	100	O	O	O	C	—
Alkylbenzene sulfonic acid					X	X	O	X	—
Alkyldimethyl ammonium chloride					X	X	O	—	—
Allyl alcohol	0	93	0	100	O	O	O	—	—
	93	209	0	100	O	—	—	—	—
Allyl chloride	0	26	0	100	X	X	O	O	—
	26	82	0	100	X	X	O	O	—
Allyl chloride phenol					X	X	O	O	—
Allyl chloroformate					X	X	O	—	—
Allyl phenol	0	130	0	100	O	—	—	—	—
Allylbenzene	20	60	0	100	O	—	—	—	—
Alphamethylstyrene					O	—	O	—	—

Chemical	Temp °C		Conc. % wt		316L	304L	C22	Ti	Zr
	Low	High	Low	High					
Alum	0	30	0	100	O	X	O	O	O
	30	75	0	100	—	X	O	O	O
	75	120	0	100	—	X	—	—	—
Alumina					O	—	O	O	—
Aluminum chloride aqueous	0	93	0	10	X	X	O	O	O
	0	93	10	100	X	X	O	C	C
	93	120	0	100	X	X	C	X	—
Aluminum chloride dry	0	21	0	10	O	O	O	X	O
	21	93	0	100	X	X	O	X	—
	93	120	10	100	X	X	—	X	—
Aluminum chlorohydroxide					X	X	O		—
Aluminum fluorosulfate	0	200	0	15	—	X	O	X	X
Aluminum nitrate	0	98	0	100	O	X	C	O	—
	98	120	0	100	X	X		—	—
Aluminum oxide					O	—	O	—	—
Aluminum silicate					O	—	O	—	—
Aluminum sulfate	0	38	0	100	X	X	O	O	O
	38	93	0	100	X	X	—	O	C
Amine No quaternary amines for stainless steel	0	100	0	100	C	X	O	—	—
	100	120	0	100	C	X	O	—	—
	120	148	0	100	X	X	O	—	—
Ammonia (aqueous) (ammonia + water)	0	30	0	50	O	O	O	O	O
	30	70	0	30	O	O	O	—	O
	30	70	30	50	O	O	O	—	O
	70	150	0	50	—	—	O	—	O
Ammonia (anhydrous)			100	100	O	O	O	X	X
Ammonium carbonate	0	20	0	30	O	X	O	O	—
	20	80	0	30	O	X	O	O	—
	80	120	0	30	—	X	—	O	—
Ammonium chloride	0	93	0	10	X	X	O	O	O
	0	82	0	50	X	X	O	O	O
	82	104	0	50	X	X	O	X	O
	104	120	0	50	X	X	O	X	O
Ammonium dihydrozene phosphate					—	—	O	—	—
Ammonium laurate					O	—	O	—	—

Chemical	Temp °C		Conc. % wt		316L	304L	C22	Ti	Zr
	Low	High	Low	High					
Ammonium laureth sulfate					O	—	O	—	—
Ammonium nitrate	0	38	0	100	X	O	O	O	O
	38	120	0	100	X	O	X	O	O
Ammonium oxalate	0	24	0	10	X	X	O	O	—
Ammonium persulfate	0	25	0	5	O	—	O	O	—
	0	25	5	10	O	—	O	O	—
	0	60	10	100	O	—	—	O	—
Ammonium phosphate	0	60	0	10	O	—	O	O	—
	0	60	10	100	—	—	O	O	—
	60	104	0	10	—	—	—	O	—
	104	120	0	10	—	—	—	O	—
Ammonium saltwater	20	80	0	15	X	X	O	—	—
Ammonium sulfate	0	104	0	10	X	X	O	O	O
	0	120	10	100	X	X	X	O	O
	104	120	0	10	X	X	O	—	—
	120	160	0	10	X	X	O	—	—
	120	149	10	100	X	X	X	—	—
Ammonium sulfide	0	70	0	100	X	X	O	—	—
	40	60	0	100	X	X	O	—	—
Ammonium thioglycolate					O	—	O	—	—
Ammonium thiosulfate					—	—	O	O	—
Amyl chloride	0	60	0	100	O	X	O	X	X
	60	120	0	100	—	X	O	X	X
	120	148	0	100	—	X	—	X	X
Amyl mercaptan	0	160	0	100	O	O	O	—	—
Amylphenol	0	200	0	100	O	O	O	—	—
Aniline	0	110	0	100	O	—	O	C	—
	110	120	0	100	C	—	O	—	—
	120	265	0	100	C	—	—	—	—
Animal fat					—	—	O	O	—
Anthracene oil	80	90	0	100	O	—	—	—	—
Anthraquinone					—	—	—	—	—
Antibiotic fermentation media						—	O	—	—
Anti-static agent 743					X	X	O	—	—

Chemical	Temp °C		Conc. % wt		316L	304L	C22	Ti	Zr
	Low	High	Low	High					
Antimony pentachloride	0	71	0	50		X	O	—	—
Apple juice					O	—	O	O	—
Aqua quinine					O	—	O	—	—
Aqua regia	0	20			X	X	X	O	X
	20	120			X	X	X	X	X
Argon					O	—	O	O	—
Arsenic acid	0	65	0	100	O	—	X	X	—
	65	120	0	100	X	—	X	X	—
Asphalt	0	60	0	100	O	—	O	O	—
	60	200	0	100	O	—	O	O	—
Atropine	0	60	0	100	O	—	O	—	—

(1) Consult Micro Motion before using zirconium with acetic acid containing copper ions.

## 7.2 B chemical tables

Table 7-2: Synonyms for B chemicals

Synonym	Listed under
1, 2 - Benzenedicarboxylic acid anhydride	Phthalic anhydride
Baking soda	Sodium bicarbonate
Battery acid	Sulfuric acid
Benzene carboxylic acid	Benzoic acid
Benzine	Benzene
Benzol	Benzene
Boron fluoride	Boron trifluoride
Boronic acid	Boric acid
Br	Bromine
Bromoform	Tribromomethane
Bromomethane	Methyl bromide
Butanal	Butyl aldehyde
Butyl alcohol	Butanol
Butylene	Butadiene
Butyraldehyde	Butyl aldehyde
Isobutyl Bromide	Butyl bromide

## 7.2.1 B chemicals with Coriolis meters

Chemical	Temp °C		Conc. % wt		SS	C22	Ta	Ti
	Low	High	Low	High				
Barium chloride	0	60	0	100	X	O	—	O
Barium sulfate	0	93	0	100	X	O	X	O
	93	120	0	100	X	O	—	—
Beef tallow					O	O	X	O
Beer	0	37	0	100	O	O	O	O
	37	150	0	100	O	—	—	O
Beeswax	0	104	0	100	—	—	O	—
Benzene	0	116	0	100	O	O	O	O
Benzene hexachloride	0	200	0	100	X	—	—	—
Benzene sulfonic acid					X	O <sup>(1)</sup>	O	X
Benzoic acid	0	82	0	10	X	O	O	O
	0	104	10	100	—	—	O	O
	104	120	10	100	—	—	—	O
Benzophenone					—	O	—	—
Benzoquinine					O	O	O	—
Benzoyl chloride					—	O	O	—
Benzoyl peroxide	0	50	0	75	O	O	O	—
Benzyl chloride	0	50	0	100	X	O	C	O
	0	120	0	100	X	X	C	—
Betaine	0	90			X	O	O	—
Black acid	0	210	0	100	X	X	O	—
Black liquor	20	80	0	100	X	O	X	X
Bleach					X	O	O	O
Boric acid	0	30	0	10	O	O	O	O
	0	120	0	10	X	O	O	O
	120	150	0	10	—	O	O	—
	150	250	0	10	—	O	—	—
Boron sulfate					—	O	O	—
Boron trifluoride	0	40			X	O	—	—
Boron trifluoride etherate	0	57	0	100	—	O	—	—
Brine					X	O	O	O
Bromethylbenzene					X	X	O	—

Chemical	Temp °C		Conc. % wt		SS	C22	Ta	Ti
	Low	High	Low	High				
Bromine (wet)	0	66			X	X	O	O
	66	93			X	X	O	O
	93	120			X	X	O	—
	120	150	0	100	X	X	O	—
Bromine (dry or anhydrous)	0	66	100	100	X	X	O	X
	0	66	0	100	X	X	O	X
Bromine water	0	65			X	O	O	O
Bromonitropropanediol					X	O	—	X
Bromotoluene					X	X	O	—
Butadiene	0	60	0	100	O	O	—	—
	60	120	0	100	—	O	—	—
Butane					O	O	O	O
Butanol					O	—	O	O
Butyl acetate	0	120	0	100	O	O	O	O
Butyl acrylate	0	40	98	100	O	O	—	—
Butyl aldehyde					O	—	O	—
Butyl bromide	0	120	0	100	X	X	O	—
Butylamine					O	O	—	—
Butylene glycol	0	120			O	O	O	—
Butyllithium in alkane	0	60	0	50	O	O	—	—

(1) Maintain a velocity of < 10 ft/sec (3 m/sec).

## 7.2.2 B chemicals with fork density and viscosity meters

Chemical	Temp °C		Conc. % wt		316L	304L	C22	Ti	Zr
	Low	High	Low	High					
Barium chloride	0	60	0	100	X	X	O	—	—
Barium sulfate	0	93	0	100	X	X	O	—	—
	93	120	0	100	X	X	O	—	—
Beef tallow					O	—	O	O	—
Beer	0	37	0	100	O	—	O	—	—
	37	150	0	100	O	—	O	—	—
Beeswax bleach solution	0	104	0	100	—	—	O	—	—
Benzene	0	116	0	100	O	—	—	O	O
Benzene hexachloride	0	200	0	100	X	—	O	—	—

Chemical	Temp °C		Conc. % wt		316L	304L	C22	Ti	Zr
	Low	High	Low	High					
Benzene sulfonic acid					X	X	O	—	—
Benzoic acid	0	82	0	10	X	X	O	O	O
	0	104	10	100	X	X	—	O	O
	104	120	10	100	X	X	—	—	O
Benzophenone					X	X	O	—	—
Benzoquinine					O	—	O	—	—
Benzoyl chloride					X	X	O	—	—
Benzoyl peroxide					O	—	O	—	—
Benzyl chloride	0	50	0	100	X	X	O	O	—
	0	120	0	100	X	X	X	—	—
Black acid	0	210	0	100	X	X	X	X	—
Black liquor	20	90	0	100	C	X	O	—	—
Bleach					X	X	O	O	—
Boric acid	0	30	0	10	O	X	O	O	O
	0	120	0	10	X	X	O	O	O
	120	150	0	10	X	X	O	—	—
	150	250	0	10	X	X	O	—	—
Boron sulfate					—	—	O	—	—
Boron trifluoride	0	50			—	X	O	—	—
Boron trifluoride etherate	0	57	0	100	—	X	O	—	—
Brine					X	X	O	O	—
Bromethylbenzene					X	X	X	—	—
Bromine (dry or anhydrous)	0	66	100	100	X	X	X	X	O
Bromine (wet)	0	66			X	X	X	O	—
	66	93			X	X	X	O	—
	93	120			X	X	X	X	X
Bromine water	0	65			X	X	O	O	O
Bromonitropropanediol					X	X	O	X	—
Butadiene	0	60	0	100	O	—	O	—	—
	60	120	0	100	—	—	O	—	—
Butane					O	O	O	—	—
Butanol					O	O	O	O	—
Butyl acetate	0	120	0	100	O	—	O	O	—
Butyl acrylate	0	40	98	100	O	—	O	—	—
Butyl aldehyde					O	—	—	—	—

Chemical	Temp °C		Conc. % wt		316L	304L	C22	Ti	Zr
	Low	High	Low	High					
Butylamine					O	—	O	—	—
Butyl bromide	0	120	0	100	X	X	X	—	—
Butylene glycol					O	—	O	—	—

## 7.3 C chemical tables

Table 7-3: Synonyms for C chemicals

Synonym	Listed under
Carbamide	Urea
Carbolic acid	Phenol
Carbon dichloride	Perchloroethylene
Carbon oxychloride	Phosgene
Carbonyl chloride	Phosgene
Carbonyl diamide	Urea
Caustic potash	Potassium hydroxide
Caustic soda	Sodium hydroxide
Chlorallylene	Allyl chloride
Chlorinated cyclic olefin	Hexachlorocyclopentadiene
Chlorine gas	Chlorine
Chlorine liquid	Chlorine
Chlorodiethylacetanilide	Alachlor technical
Chloroethanol	Ethylene Chlorohydrin
Chloroethylen	Vinyl chloride
Chloromethane	Methyl chloride
Chloropentane	Amyl chloride
CIP	See each fluid used, or contact customer support
CNG	Compressed natural gas
Crude oil	Oil, crude
Cupric sulfate	Copper sulfate
Cyanhydrin, cyanohydrin	Acetone cyanohydrin

### 7.3.1 C chemicals with Coriolis meters

Chemical	Temp °C		Conc. % wt		SS	C22	Ta	Ti
	Low	High	Low	High				
Calcium bromide	0	60	0	50	X	O	O	—
Calcium carbonate					O	O	O	O

Chemical	Temp °C		Conc. % wt		SS	C22	Ta	Ti
	Low	High	Low	High				
Calcium chloride	0	93	0	40	X	O	O	O
	0	93	40	100	X	O	O	O
	93	120	0	40	X	X	O	O
	93	120	40	100	X	X	—	X
	120	200	4	100	X	X	—	—
Calcium hydroxide	0	50	0	50	O	O	X	O
	0	100	0	50	X	O	X	X
Calcium hypochlorite	0	60	0	15	X	O	X	O
Calcium lignosulphonate					—	O	—	—
Calcium pyridine sulfonate	0	66	0	100	—	O	—	—
Calcium stearate	0	60	0	40	O	O	—	O
Calcium sulfide	0	47	0	100	X	O	O	—
Calcium thiosulfate	0	38	0	30	O	O	—	O
Canola oil					O	O	—	—
Carbolite					O	O	O	—
Carbon dioxide (dry)	0	120	0	100	O	O	O	—
Carbon dioxide (wet)	0	120	0	100	X	C	O	—
Carbon disulfide	0	43	0	100	O	—	O	O
	43	65	0	100	—	—	X	O
	65	93	0	100	—	—	—	O
Carbon tetrachloride (anhydrous)	0	60	0	100	O	O	O	O
	60	120	0	100	—	—	O	O
Carbon tetrachloride (wet)					X	O	O	O
Carbon tetrafluoride					X	—	—	—
Carbonic acid (wet)					X	O	O	O
Carbonochloric acid					X	O	O	—
Carboxylic acid salts					—	O	—	—
Ceda clean					—	O	—	—
Cement					O	O	—	—
Cerium acetate					—	O	O	—
Cetylpyridinium					O	O	—	—
Cetylpyridinium chloride					X	O	O	—
Chloric acid	0	31	0	20	X	O	O	—
	0	70	0	50	X	X	O	—
Chlorinated hydrocarbons					X	O	O	—

Chemical	Temp °C		Conc. % wt		SS	C22	Ta	Ti
	Low	High	Low	High				
Chlorinated phenol					X	O	O	—
Chlorinated pyridine					X	O	O	—
Chlorinated, fluorinated pyradines					X	O	O	—
Chlorine (anhydrous gas or liquid)	-40	0	0	100	X	O	O	X
	0	104	0	100	X	O	O	X
Chlorine (wet)	0	120	0	100	X	X	O	—
Chlorine dioxide	0	40	0	15	X	O	O	O
	0	120	0	100	X	X	O	C
Chloro nitro ethane					X	O	O	—
Chloro trifluoro-ethylene	0	49	0	100	—	O	O	—
Chloroacetic acid					X	O	O	C
Chloroacetyl chloride					X	O	O	—
Chlorobenzene	0	38	0	60	X	O	O	O
Chlorodifluoroethane					X	O	O	—
Chlorodifluoromethane					X	—	—	—
Chloroethane	0	93	0	100	X	O	O	—
Chloroform	0	21	0	100	O	O	O	O
	21	95	0	100	X	X	O	O
	95	104	0	100	X	X	O	O
Chloromethylisothiazolinone					X	O	—	—
Chlorophenol	0	60	0	5	X	O	—	—
Chloropicrin	0	95	0	100	X	O	O	—
Chlorosilane					—	O	O	—
Chlorosulfonic acid	0	85	0	100	X	O <sup>(1)</sup>	O	X
Chlorotetrahydrophthalic anhydride					X	O	O	—
Chocolate					O	—	—	O
Choline chloride					X	O	O	—
Chromic oxide (based on 50% chromic acid)					—	O	O	—
Chromium trioxide; chromic acid			0	100	—	—	—	O
Chromium sulfate					O	O	O	—
Citric acid	0	100	0	50	O	O	O	O
	100	120	0	50	X	O	O	X
Coal tar fuel					O	O	O	—
Coal tar pitch					O	O	O	—
Cobalt hydroxide	0	200	0	100	X	—	X	—

Chemical	Temp °C		Conc. % wt		SS	C22	Ta	Ti
	Low	High	Low	High				
Cobalt octoate					O	O	—	—
Cocoa butter					O	—	O	O
Coconut oil					O	—	O	O
Concrete					O	O	O	—
Copper bromide					X	—	O	—
Copper sulfate	0	104	0	100	X	O	O	O
Corn oil					O	O	O	O
Corn oil and garlic					O	O	O	—
Corn steep liquor					O	O	O	—
Corn syrup					O	O	O	O
Creosote oil					X	O	—	O
Cresol					O	O	—	O
Cresylic acid	0	100	0	100	—	O	O	O
Cupric bromide	0	30	0	100	X	X	O	—
Cupric chloride	0	104	0	5	X	X	O	O
	0	21	5	50	X	O	O	O
	21	120	5	50	X	X	O	O
Cyanogen bromide					X	X	O	X
Cyanogen chloride	0	46	0	20	—	O	O	—
Cyclohexane	0	93	0	100	O	X	X	O
	93	120	0	100	O	X	—	O
Cyclopropylamine					O	O	—	—

(1) Maintain a velocity of < 10 ft/sec (3 m/sec).

### 7.3.2 C chemicals with fork density and viscosity meters

Chemical	Temp °C		Conc. % wt		316L	304L	C22	Ti	Zr
	Low	High	Low	High					
Calcium chloride	0	93	0	40	X	X	O	O	O
	0	93	40	100	X	X	O	O	O
	93	120	0	40	X	X	O	O	O
	93	120	40	100	X	X	O	O	O
	120	150	0	100	X	X	O	O	X
Calcium hydroxide	0	50	0	50	O	—	O	O	O
	0	100	0	50	—	—	O	O	O
Calcium hypochlorite	0	60	0	15	X	X	O	O	—

Chemical	Temp °C		Conc. % wt		316L	304L	C22	Ti	Zr
	Low	High	Low	High					
Calcium lignosulphonate					—	X	O	—	—
Calcium pyridine sulfonate	0	66	0	100	—	X	O	—	—
Calcium sulfide	0	50	0	10	O	—	O	—	—
	0	25	0	100	O	—	O	—	—
	25	100	0	100	—	—	O	—	—
Calcium thiosulfate	0	38	0	30	O	—	O	O	—
Canola oil					O	—	O	—	—
Carbolite					O	—	O	—	—
Carbon dioxide	0	120			O	—	O	—	—
Carbon disulfide	0	43	0	100	O	—	O	O	—
	43	65	0	100	—	—	O	O	—
	65	93	0	100	—	—	—	O	—
Carbon tetrachloride	0	60			O	—	O	O	—
	60	120			—	—	O	O	—
	0	100	0	100	X	X	O	O	—
Carbon tetrafluoride					X	X	O	X	—
Carbonic acid					X	X	O	—	—
Carbochloric acid					X	X	O	—	—
Carboxylic acid salts					—	—	O	—	—
Cement					O	—	O	—	—
Cerium acetate					O	—	O	—	—
Cetylpyridinium					O	—	O	—	—
Cetylpyridinium chloride					—	—	O	—	—
Chloric acid	0	31	0	20	X	X	O	X	—
	0	70	0	50	X	X	—	X	—
Chlorinated hydrocarbons					—		O	—	—
Chlorinated phenol					X	X	O	—	—
Chlorinated pyridine					X	X	O	—	—
Chlorinated, fluorinated pyridines					X	X	O	—	—
Chlorine	0	104	0	100	C	X	O	X	X
	0	120	0	100	X	X	O	O	X
Chlorine dioxide	0	40	0	15	X	X	O	O	—
	0	120	0	100	X	X	X	—	—
Chloro nitro ethane					X	X	O	—	—

Chemical	Temp °C		Conc. % wt		316L	304L	C22	Ti	Zr
	Low	High	Low	High					
Chloro trifluoroethylene	0	49	0	100	—		O	—	—
Chloroacetic acid					X	X	O	—	O
Chloroacetyl chloride					X	X	O	—	—
Chlorobenzene	0	38	0	60	X	X	O	O	O
Chlorodifluoroethane					—	—	O	—	—
Chlorodifluoromethane					—	—	O	—	—
Chloroform	0	21	0	100	X	X	O	O	—
	21	95	0	100	X	X	—	O	—
	95	104	0	100	X	X	—	O	—
Chlorophenol	0	60	0	5	X	X	O	—	—
Chloropicrin	0	95	0	100	X	X	O	O	—
Chlorosilane					—	—	O	—	—
Chlorosulfonic acid	0	85	0	100	X	X	O	X	—
Chlorotetrahydrophthalic anhydride					X	X	O	—	—
Chocolate					O	—	—	O	—
Choline chloride					X	X	O	—	—
Chromic oxide					X	X	O	—	—
Chromium trioxide			0	100	—	—	—	O	—
Chromium sulfate					—	—	O	—	—
Citric acid	0	100	0	50	O	C	O	O	O
	100	120	0	50	X	X	O	X	O
Coal tar fuel					O	—	O	—	—
Coal tar pitch					O	—	O	—	—
Cobalt octoate					O	—	O	—	—
Cocoa butter					O	—	O	O	—
Coconut oil					O	—	O	—	—
Coke gas oil					—	—	O	—	—
Concrete					O	—	O	—	—
Copper bromide					X	X	O	—	—
Copper sulfate	0	104	0	100	—	—	O	O	—
Corn oil					O	—	O	O	—
Corn oil and garlic					O	—	O	—	—
Corn steep liquor					O	—	O	—	—
Corn syrup					O	—	O	O	—

Chemical	Temp °C		Conc. % wt		316L	304L	C22	Ti	Zr
	Low	High	Low	High					
Creosote oil					—	—	O	O	—
Cresol					O	—	O	O	—
Cresylic acid	0	100	0	100	—	—	O	O	—
Cupric bromide	0	30	0	100	X	X	O	—	—
Cupric chloride	0	104	0	5	X	X	O	O	X
Cupric chloride	0	21	5	50	X	X	O	O	X
	21	120	5	50	X	X	C	O	X
Cyanogen chloride	0	46	0	20	—	—	O	—	—
Cyclohexane	0	93	0	100	O	—	—	O	O
	93	120	0	100	O	—	—	O	—
Cyclopropylamine					O	—	O	—	—

## 7.4 D chemical tables

Table 7-4: Synonyms for D chemicals

Synonym	Listed under
1,3 - Dioxophthalan	Phthalic anhydride
Darammon	Ammonium chloride
DEAC	Dimethylacetimide
Deionized water	Water
Dichloroethane	Ethylene dichloride
Dichloroethylene	Vinylidene chloride
Dichloromethane	Methylene chloride
Diethylene oxide	Tetrahydrofuran
Diethyl ether	Ether
Dihydroxyethane	Ethylene glycol
Dimethyl benzene	Xylene
Dimethyl ketone	Acetone
Dipping acid	Sulfuric acid
DMAC	Dimethylacetimide
DMAPA	Dimethylaminopropylamine
DMI	Diphenyl methane diisocyanate
Dodecyl bromide	Lauryl bromide

### 7.4.1 D chemicals with Coriolis meters

Chemical	Temp °C		Conc. % wt		SS	C22	Ta	Ti
	Low	High	Low	High				
Decane sulfonyl fluoride					X	—	—	—
Diacryl phthalate	0	15	0	100	O	—	O	—
Dibromo- benzene	0	200	0	100	X	—	O	—
Dibromonitrilopropionamide					X	O	—	X
Dichloroacetyl chloride					X	—	—	—
Dichloro- benzene			0	120	X	O	—	X
Dichlorobutene					X	O	O	—
Dichloro- difluoro- methane	0	21	0	100	X	O	O	O
	21	71	0	100	X	—	—	—
Dichlorofluoroethane					—	O	O	O
Dichlorophenol	0	120	0	100	X	O	O	—
Dichlorotrifluoroethane					X	—	—	—
Diesel fuel	0	38	0	100	O	O	—	X

Chemical	Temp °C		Conc. % wt		SS	C22	Ta	Ti
	Low	High	Low	High				
	38	120	0	100	O	O	—	—
Diethano- lamine	0	100	0	100	O	O	O	O
Diethyl aluminum chloride					X	—	O	—
Diethyl disulfide	0	90	0	100	—	O	O	—
Diethyl sulfate					—	O	O	—
Diethyl sulfide					—	O	O	—
Diethylamine	0	120	0	100	O	X	—	X
Diethylene glycol	0	52	0	100	O	X	—	O
	52	76	0	100	O	—	—	O
Difluorobenzonitrile					—	—	—	—
Difluoromono-chlorethane					—	O	—	—
Diisononylphtalate					O	O	—	—
Diisopropyl peroxydicarbonate					O	O	—	—
Dimethyl aminoethyl methacrylate					O	—	O	—
Dimethyl chloride					X	O	O	—
Dimethyl dichloride					X	O	O	—
Dimethyl disulfide					O	O	O	—
Dimethyl formaldehyde					O	—	O	—
Dimethyl hydrazine					O	O	—	—
Dimethyl malonate	0	100	0	100	—	O	O	—
Dimethyl succinate			0	100	O	O	O	—
Dimethyl sulfate					O	O	O	—
Dimethyl sulfide					O	O	O	—
Dimethyl terephthalate					O	—	O	—
Dimethyl- acetamide	0	200	0	100	X	O	—	—
Dimethyl- amine	25	180	0	100	O	O	O	X
Dimethyl- amino- propylamine	0	90			O	O	—	—
Dimethyl- formamide	0	60	0	100	X	O	—	—
Dimethylpolysiloxanes					O	O	O	—
Dimethyltin dichloride					X	O	—	—
Dinitrotoluene					O	O	O	—
Diphenyl methane diisocyanate (drainable is best)					O	O	—	—
Diphenylamine	0	100	0	100	—	O	O	—
Dipropyl peroxydicarbonate					O	O	—	—

Chemical	Temp °C		Conc. % wt		SS	C22	Ta	Ti
	Low	High	Low	High				
Dipropylene glycol monomethyl ether					O	—	O	O
Disobutylene					O	O	O	—
Disodium iminodiacetate					X	—	—	—
Divinylbenzene					O	O	—	—
Dodecyl mercaptan					O	O	O	—
Dodecylbenzene sulfonic acid					X	O <sup>(1)</sup>	O	—
Drilling mud					O	O	—	O

(1) Maintain a velocity of < 10 ft/sec (3 m/sec).

## 7.4.2

### D chemicals with fork density and viscosity meters

Chemical	Temp °C		Conc. % wt		316L	304L	C22	Ti	Zr
	Low	High	Low	High					
Decane sulfonyl fluoride					X	X	O	X	X
Diacryl phthalate	0	15	0	100	O	—	O	—	—
Dibromobenzene	0	200	0	100	X	X	—	—	—
Dichloroacetyl chloride					X	X	O	—	—
Dichlorobenzene					—	X	O	—	—
Dichlorobutene					—	X	O	—	—
Dichloro-difluoromethane	0	21	0	100	C	—	O	—	—
	21	71	0	100	—	—	O	—	—
Dichlorofluoroethane					—	—	O	—	—
Dichlorophenol	0	120	0	100	X	X	O	—	—
Dichlorotrifluoroethane					—	—	O	—	—
Diesel fuel	0	38	0	100	O	—	O	—	—
	38	120	0	100	O	—	O	—	—
Diethanolamine	0	100	0	100	O	—	O	O	—
Diethyl aluminum chloride					X	X	O	—	—
Diethylamine	0	120	0	100	O	—	—	X	—
Diethyl disulfide	0	90	0	100	—	—	O	—	—
Diethylene glycol	0	52	0	100	O	—	—	O	—
	52	76	0	100	O	—	—	—	—
Diethyl sulfate					—	—	O	—	—
Diethyl sulfide					—	—	O	—	—
Difluorobenzonitrile					—	X	O	X	—
Difluoromonochlorethane					—	—	O	—	—

Chemical	Temp °C		Conc. % wt		316L	304L	C22	Ti	Zr
	Low	High	Low	High					
Diisononylphtalate					O	—	O	—	—
Diisopropyl peroxydicarbonate					O	—	O	—	—
Dimethylacetamide	0	200	0	100	X	O	—	—	—
Dimethylamine	25	180	0	100	O	—	—	X	—
Dimethyl aminoethyl methacrylate					O	—	—	—	—
Dimethyl chloride					X	X	O	—	—
Dimethyl dichloride					X	X	O	—	—
Dimethyl formaldehyde					O	—	—	—	—
Dimethyl hydrazine					O	O	O	—	—
Dimethyl malonate	0	100	0	100	—	—	O	—	—
Dimethylpolysiloxanes					O	—	O	—	—
Dimethyl succinate			0	100	O	—	O	—	—
Dimethyl sulfate					O	—	O	—	—
Dimethyl sulfide					O	—	O	—	—
Dimethyl terephthalate					O	—	—	—	—
Dimethyltin dichloride					X	X	O	—	—
Dinitrotoluene					O	—	O	—	—
Diphenylamine	0	100	0	100	—	—	O	—	—
Diphenyl methane diisocyanate					O	—	O	—	—
Dipropylene glycol monomethyl ether					O	—	O	—	—
Dipropyl peroxydicarbonate					O	—	O	—	—
Disobutylene					O	—	O	—	—
Disodium iminodiacetate					X	X	O	—	—
Divinylbenzene					O	—	O	—	—
Dodecylbenzene sulfonic acid					X	X	O	X	—
Dodecyl mercaptan					O	—	O	—	—
Drilling mud					O	—	O	O	—

## 7.5 E chemical tables

Table 7-5: Synonyms for E chemicals

Synonym	Listed under
Epsom salt	Magnesium sulfate
Ethanal	Acetaldehyde
Ethanoate	Acetate
Ethanoic acid	Acetic acid

**Table 7-5: Synonyms for E chemicals (continued)**

Synonym	Listed under
Ethanol	Ethyl alcohol
Ethanonitrile	Acetonitrile
Ethanoyl chloride	Acetyl chloride
Ethenyl benzene	Styrene
Ethyl aldehyde	Acetaldehyde
Ethylene chloride	Ethylene dichloride
Ethyl ethanoate	Ethyl acetate
Ethylic acid	Acetic acid
Ethyne	Acetylene
Ethyrene	Butadiene

## 7.5.1 E chemicals with Coriolis meters

Chemical	Temp °C		Conc. % wt		SS	C22	Ta	Ti
	Low	High	Low	High				
Egg slurry					O	O	O	O
Epichlorohydrin (dry)	0	60	0	100	O	O	O	—
Epoxy resin					O	O	—	O
Ercimide					—	O	O	—
Ester vinyl ether					X	O	—	—
Ethane (H2S free)					O	O	—	—
Ethanol					O	O	O	C
Ether	20	100	0	100	O	X	O	O
Ethyl acetate	0	65	0	100	O	O	O	C
Ethyl alcohol					O	O	O	C
Ethyl benzene	0	60	0	100	O	O	—	—
	60	100	0	100	O	O	—	—
Ethyl Chloride	0	93	0	100	X	O	O	—
Ethyl monochloroacetate					X	O	O	—
Ethylbenzene sulfonyl fluoride					—	O	—	—
Ethylene					O	O	O	—
Ethylene chlorohydrin	0	100	0	100	X	O	—	X
Ethylene diamine	0	37	0	100	O	X	X	O
	37	43	0	100	—	X	X	—
Ethylene dichloride	0	93	0	100	X	O	O	C

Chemical	Temp °C		Conc. % wt		SS	C22	Ta	Ti
	Low	High	Low	High				
Ethylene glycol	0	120	0	100	O	O	O	X
	120	200	0	100	—	O	—	X
Ethylene glycol/ bromoform				97	X	—	O	—
Ethylene oxide	0	31	0	100	O	O	O	O
	31	120	0	100	O	—	—	—
Ethylhexyl acrylate					O	O	O	—
Ethylpropylacrolein					O	O	—	—
Evaposhine					X	O	O	—

## 7.5.2 E chemicals with fork density and viscosity meters

Chemical	Temp °C		Conc. % wt		316L	304L	C22	Ti	Zr
	Low	High	Low	High					
Egg slurry					O	—	O	O	—
Epichlorohydrine (dry)	0	60	100	100	O	—	O	—	—
Epoxy resin					O	—	O	O	—
Ercimide					—	—	O	—	—
Ester vinyl ether					—	—	O	—	—
Ethanol					O	O	O	C	—
Ether	20	100	0	100	O	—	—	O	—
Ethyl acetate	20	65	0	100	O	O	O	O	—
Ethyl alcohol					O	O	O	C	—
Ethyl benzene	0	60	0	100	O	—	O	—	—
	60	100	0	100	O	—	O	—	—
Ethylbenzene sulfonyl fluoride					—	—	O	—	—
Ethylene					O	—	O	—	—
Ethylene chlorohydrin	0	100	0	100	—	X	O	—	—
Ethylene diamine	0	37	0	100	O	—	O	O	—
	37	43	0	100	—	—	O	—	—
Ethylene dichloride	0	93	0	100	X	X	O	O	O
Ethylene glycol	0	120	0	100	O	—	O	O	—
	120	200	0	100	—	—	O	—	—
Ethylene glycol, bromoform					97	X	X	X	—

Chemical	Temp °C		Conc. % wt		316L	304L	C22	Ti	Zr
	Low	High	Low	High					
Ethylene oxide	0	31	0	100	O	—	O	—	—
	31	120	0	100	O	—	—	—	—
Ethyl monochloroacetate					X	X	O	—	—
Ethylproplacrolein					O	—	O	—	—
Evaposhine					X	X	O	—	—

## 7.6 F chemical tables

Table 7-6: Synonyms for F chemicals

Synonym	Listed under
Formalin	Formaldehyde
Freon 10	Carbon tetrachloride
Freon 113	Trichlorotrifluoroethane
Freon 12	Dichlorodifluoromethane
Freon 17	Trichloromonofluoroethane
Freon 22	Monochlorodifluoromethane
Fuel oil	Oil, fuel
Fuming sulfuric acid	Oleum

### 7.6.1 F chemicals with Coriolis meters

Chemical	Temp °C		Conc. % wt		SS	C22	Ta	Ti
	Low	High	Low	High				
Fat/Garlic					O	O	—	O
Fatty acid	0	120	0	100	C	O	O	O
	120	200	0	100	C	O	O	—
Ferric chloride	0	25	0	10	X	O	O	O
	25	93	0	100	X	X	O	O
Ferric nitrate	0	20	0	100	X	O	O	O
	20	120	0	100	X	—	—	O
Ferric nitrite					O	O	O	—
Ferric sulfate	0	60	0	10	O	O	O	O
	0	60	10	30	—	O	O	O
	0	98	30	100	—	—	O	O
	60	98	0	10	—	—	O	O
	60	98	10	30	—	—	O	O

Chemical	Temp °C		Conc. % wt		SS	C22	Ta	Ti
	Low	High	Low	High				
Ferrous chloride	0	25	0	10	—	O	O	O
	0	120	0	100	X	X	O	O
Ferrous sulfate	0	120	0	100	X	O	O	O
Fluorine (dry)	0	100			X	O	X	O
Fluoroalcohol					X	—	—	—
Fluorobenzene					X	—	—	—
Fluorosilicic acid			10	50	X	X	X	X
Fluorosulfonic acid					X	—	X	—
Fluorotrichloromethane					X	—	—	—
Food product					—	O	O	—
Formaldehyde					O	—	—	X
Formic acid (aerated)	0	30	0	10	O	O	O	O
	0	100	0	5	X	O	O	O
	100	120	0	5	X	—	O	X
	120	153	0	5	X	—	O	X
Formic acid (non aerated)	0	104	10	100	X	O	O	X
Fruit juice					O	O	O	O

## 7.6.2 F chemicals with fork density and viscosity meters

Chemical	Temp °C		Conc. % wt		316L	304L	C22	Ti	Zr
	Low	High	Low	High					
Fat/Garlic					O	—	O	O	—
Fatty acid	0	120	0	100	C	—	O	—	—
	120	200	0	100	C	—	O	—	—
Ferric chloride	0	25	0	10	X	X	O	O	X
	25	93	0	100	X	X	—	O	X
Ferric nitrate	0	20	0	100	O	X	X	O	—
	20	120	0	100	X	X	X	O	—
Ferric nitrite					O	—	O	—	—
Ferric sulfate	0	60	0	10	O	X	O	O	O
	0	60	10	30	—	X	O	O	O
	0	98	30	100	—	X	—	O	—
	60	98	0	10	—	X	—	O	O
	60	98	10	30	—	X	—	O	O

Chemical	Temp °C		Conc. % wt		316L	304L	C22	Ti	Zr
	Low	High	Low	High					
Ferrous chloride	0	25	0	10	X	X	O	O	O
	0	120	0	50	X	X	—	—	O
Ferrous sulfate	0	100	0	30	X	X	O	O	O
	0	100	30	50	X	X	—	O	O
	0	100	50	100	X	X	—	O	—
Fluoroalcohol					X	X	O	X	X
Fluorobenzene					X	X	O	X	X
Fluorosulfonic acid					X	X	—	X	X
Fluorotrichloromethane					X	X	O	X	X
Food product					—	—	O	—	—
Formaldehyde					O	—	—	X	—
Formic acid	0	30	0	10	O	—	O	O	O
	0	100	0	5	O	X	O	C	O
	0	75	10	100	X	C	O	X	O
	100	120	0	5	O	X	O	X	O
	120	153	0	5	X	X	—	X	—
Fruit juice					O	—	O	—	—

## 7.7 G chemical tables

Table 7-7: Synonyms for G chemicals

Synonym	Listed under
Glycol	Ethylene glycol
Glyphosate	Roundup herbicide

### 7.7.1 G chemicals with Coriolis meters

Chemical	Temp °C		Conc. % wt		SS	C22	Ta	Ti
	Low	High	Low	High				
Gasoline	0	43	0	100	O	O	O	O
	43	120	0	100	—	O	—	—
Gelatin					O	—	—	O
Geranyl ester					O	O	O	—
Glutaraldehyde	0	100			O	O	—	—
Glycerine	0	120	0	100	O	O	O	O
Glycolite					O	O	O	—

Chemical	Temp °C		Conc. % wt		SS	C22	Ta	Ti
	Low	High	Low	High				
Glyoxylic acid	0	50			X	O	O	—
Green liquor					—	O	—	X

## 7.7.2 G chemicals with fork density and viscosity meters

Chemical	Temp °C		Conc. % wt		316L	304L	C22	Ti	Zr
	Low	High	Low	High					
Gasoline	0	43	0	100	O	—	O	—	—
	43	120	0	100	—	—	O	—	—
Gelatin					O	—	O	O	—
Geranyl ester					O	—	O	—	—
Glycerine	0	104	0	100	O	O	O	O	—
Glycolite					O	—	O	—	—
Glyoxylic acid	0	50			X	X	O	—	—

## 7.8 H chemical tables

Table 7-8: Synonyms for H chemicals

Synonym	Listed under
Hartshorn	Ammonium carbonate
Hexandioic acid, hexanedioic acid	Adipic acid
Hydoxy benzoic acid	Salicylic acid
Hydraulic cylinder oil	Oil, hydraulic cylinder
Hypo photographic solution	Sodium thiosulfate

### 7.8.1 H chemicals with Coriolis meters

Chemical	Temp °C		Conc. % wt		SS	C22	Ta	Ti
	Low	High	Low	High				
Halogenated alkyl ether					X	—	O	—
Halogenated styrene					—	O	O	—
Helium					O	O	O	O
Heptane	0	60	0	100	O	O	O	O
	60	98	0	100	O	O	—	O
Hexachlorocyclopentadiene; chlorinated cyclic olefin					X	X	O	—
Hexafluoropropene					—	O	O	—
Hexahydrophthalic anhydride					O	O	—	—
Hexamethylenediisocyanate					—	O	O	—

Chemical	Temp °C		Conc. % wt		SS	C22	Ta	Ti
	Low	High	Low	High				
Hexane					O	O	X	O
Hydrazine					O	O	—	—
Hydrobromic acid					X	X	O	X
Hydrochloric acid	0	30	0	5	X	O	O	X
	0	120	0	15	X	C	O	X
	0	120	15	38	X	X	O	X
	120	200	0	38	X	X	O	X
Hydrofluoric acid (aqueous)	0	120	0	100	X	X	X	X
Hydrofluosilicic acid			10	50	X	X	X	X
Hydrogen	0	120	0	100	O	O <sup>(1)</sup>	X	X
	120	200	0	100	O	O <sup>(1)</sup>	X	X
Hydrogen bromide					X	X	O	—
Hydrogen chloride (moist)					X	—	O	X
Hydrogen chloride (anhydrous)					O	O	O	X
Hydrogen cyanide	0	31	0	100	O	O	—	O
	31	53	0	100	—	O	—	—
	53	120	0	100	—	—	—	—
Hydrogen fluoride (anhydrous)	0	43	0	100	X	O	X	X
Hydrogen peroxide	0	90	0	5	O	O	X	X
	0	38	0	30	O	O	X	X
	0	48	50	90	X	O	X	X
Hydrogen peroxide (acid free)	0	90	5	50	X	O	X	X
Hydrogen sulfide (anhydrous gas)	0	31	0	100	O	O	O	O
	31	82	0	100	O	O	O	—
	82	120	0	100	X	—	O	—
Hydrogen sulfide (moist gas)	0	38	0	100	X	O	O	O
	38	120	0	100	X	—	O	—
Hydrogen sulfide (aqueous solution)					X	X	O	X
Hydroquinone					O	O	O	X
Hydroxymethyl ester					O	O	—	—
Hydroxyethylacrylate	0	38			O	O	—	—
Hydroxyphenylethanone					O	O	—	—
Hydroxypropylmethylcellulose					X	—	O	—

Chemical	Temp °C		Conc. % wt		SS	C22	Ta	Ti
	Low	High	Low	High				
Hypochlorite					X	O	O	—
Hypochlorous acid					X	O	O	O

(1) 7,000 psi (483 bar) maximum

## 7.8.2 H chemicals with fork density and viscosity meters

Chemical	Temp °C		Conc. % wt		316L	304L	C22	Ti	Zr
	Low	High	Low	High					
Halogenated alkyl ether					—	X	O	—	—
Halogenated styrene					—	X	O	—	—
Helium					O	—	O	O	—
Heptane	0	60	0	100	O	—	O	O	—
	60	98	0	100	O	—	O	O	—
Hexachlorocyclopentadiene					X	X	X	—	—
Hexafluoropropene					—	X	O	—	—
Hexahydrophthalic anhydride					O	—	O	—	—
Hexamethylenediisocyanate					—	—	O	—	—
Hexane					O	—	O	—	—
Hydrazine					—	O	—	—	—
Hydrobromic acid					X	X	C	X	C
Hydrochloric acid	0	40	0	5	X	X	O	X	O <sup>(1)</sup>
	0	25	0	8	X	X	O	X	O <sup>(1)</sup>
	0	100	0	25	X	X	X	X	O <sup>(1)</sup>
	0	40	8	40	X	X	X	X	O <sup>(1)</sup>
Hydrofluoric acid (aqueous)	0	21	0	10	X	X	C	X	X
	21	120	10	100	X	X	C	X	X
Hydrofluosilicic acid			10	50	X	X	C	X	X
Hydrogen cyanide	0	31	0	100	O	—	O	—	—
	31	53	0	100	—	—	O	—	—
	53	120	0	100	—	—	—	—	—
Hydrogen peroxide	0	90	0	5	O	—	O	—	O
	0	38	0	30	O	O	O	—	—
	0	90	0	50	X	X	O	X	O
	0	48	50	90	X	X	O	X	—
Hydroquinone					O	—	O	X	—
Hydroxymethyl ester					O	—	O	—	—

Chemical	Temp °C		Conc. % wt		316L	304L	C22	Ti	Zr
	Low	High	Low	High					
Hydroxyethylacrylate					O	—	O	—	—
Hydroxyphenylethanone					O	—	O	—	—
Hydroxypropylmethylcellulose					—	—	O	—	—
Hypochlorous acid					X	X	O	O	—

(1) Consult Micro Motion before using Zr when oxidizing impurities are present, such as ferric ions  $Fe^{+3}$  or cupric ions  $Cu^{+2}$ .

## 7.9 I chemical tables

Table 7-9: Synonyms for I chemicals

Synonym	Listed under
Isopropanol	Isopropyl alcohol

### 7.9.1 I chemicals with Coriolis meters

Chemical	SS	C22	Ta	Ti
Ice cream	O	O	O	O
Igepon surfactant	O	O	—	—
Ink	O	—	O	O
Insulin extract	—	O	O	—
Isobutane	O	O	O	—
Isobutanol	O	—	O	O
Isobutyl acetate	O	—	O	—
Isobutyl Bromide	X	X	O	—
Isooctyl alcohol	O	O	—	—
Isopar E	O	O	—	—
Isopentane	O	O	—	—
Isopropyl acetate	O	O	—	—
Isopropyl alcohol	O	O	O	O
Isopropylamine	O	O	—	—

### 7.9.2 I chemicals with fork density and viscosity meters

Chemical	316L	304L	C22	Ti	Zr
Ice cream	O	—	O	—	—
Igepon surfactant	O	—	O	—	—
Ink	O	—	O	—	—
Insulin extract	—	—	O	—	—

Chemical	316L	304L	C22	Ti	Zr
Isobutane	O	—	O	—	—
Isobutanol	O	—	O	—	—
Isobutyl acetate	O	—	O	—	—
Isooctyl alcohol	O	—	O	—	—
Isopar E	O	—	O	—	—
Isopentane	O	—	O	—	—
Isopropyl acetate	O	—	O	—	—
Isopropyl alcohol	O	—	O	O	—
Isopropylamine	O	—	O	—	—

## 7.10 J chemical tables

Table 7-10: Synonyms for J chemicals

Synonym	Listed under
JP-4, JP-5	Jet fuel

### 7.10.1 J chemicals with Coriolis meters

Chemical	Temp °C		Conc. % wt		SS	C22	Ta	Ti
	Low	High	Low	High				
Jet fuel	0	30	0	100	O	O	O	O

### 7.10.2 J chemicals with fork density and viscosity meters

Chemical	Temp °C		Conc. % wt		316L	304L	C22	Ti	Zr
	Low	High	Low	High					
Jet fuel	0	30	0	100	O	—	O	—	—

## 7.11 K chemical tables

Table 7-11: Synonyms for K chemicals

Synonym	Listed under
KOH	Potassium hydroxide

### 7.11.1 K chemicals with Coriolis meters

Chemical	SS	C22	Ta	Ti
Kathon LX	X	O	O	—
Kerosene	O	O	O	O
Ketchup	O	O	O	O

## 7.11.2 K chemicals with fork density and viscosity meters

Chemical	316L	304L	C22	Ti	Zr
Kathon Lx 1.5% biocide	X	X	O	—	—
Kerosene	O	—	O	O	—
Ketchup	O	—	O	O	—

## 7.12 L chemical tables

Table 7-12: Synonyms for L chemicals

Synonym	Listed under
Li	Lithium
Lime	Limestone
Lime sulfur	Calcium sulfide
Liquid chlorine	Chlorine
Liquor, waste	Black liquor
LPG	Liquefied petroleum gas
Lube oil	Oil, lube
Lycine	Betaine

### 7.12.1 L chemicals with Coriolis meters

Chemical	Temp °C		Conc. % wt		SS	C22	Ta	Ti
	Low	High	Low	High				
Lactic acid	0	49	0	10	O	O	O	C
	0	49	10	25	O	O	O	C
	49	104	0	10	X	O	O	C
	49	60	10	25	X	O	O	C
	104	120	0	10	—	—	O	C
			25	100	X	C	O	C
Lactose	0	100	0	100	O	—	—	—
Lacquer thinner; lupranate					O	O	O	O
Lard oil					O	O	O	O
Lasso herbicide					X	—	O	—
Latex	0	60	0	100	O	—	—	O
Latex emulsion					O	O	—	O
Laurylamine oxide					O	O	—	—
Lauryl bromide					X	O	O	—
Lead acetate	0	104	0	100	O	O	O	O
Lime slurry <sup>(1)</sup>	0	55	0	100	X	O	—	C

Chemical	Temp °C		Conc. % wt		SS	C22	Ta	Ti
	Low	High	Low	High				
Limestone <sup>(1)</sup>	0	49	0	8	C	O	O	C
Liquified petroleum gas					O	O	O	O
Lithium bromide					X	O	O	—
Lithium chloride	0	93	0	60	X	O	O	O

(1) Maintain a velocity of < 10 ft/sec (3 m/sec).

## 7.12.2 L chemicals with fork density and viscosity meters

Chemical	Temp °C		Conc. % wt		316L	304L	C22	Ti	Zr
	Low	High	Low	High					
Lactic acid	0	49	0	10	O	—	O	O	O
	0	49	10	25	O	—	O	—	O
	49	104	0	10	—	—	O	—	O
	49	60	10	25	—	—	O	—	O
	104	120	0	10	—	—	O	—	O
	0	30	25	100	—	—	O	—	O
Lactose	0	100	0	100	O	—	O	—	—
Lacquer thinner/lupranate					O	—	O	O	—
Lard oil					O	—	O	O	—
Lasso herbicide					X	X	O	—	—
Latex	0	60	0	100	O	—	O	O	—
Latex emulsion					O	—	O	O	—
Laurylamine oxide					O	—	O	—	—
Lauryl bromide					X	X	O	—	—
Lead acetate	0	104	0	100	O	—	O	O	—
Lime slurry	0	55	0	100	—	—	O	O	—
Limestone <sup>(1)</sup>	0	49	0	8	—	—	O	O	—
Lithium bromide					X	X	O	—	—
Lithium chloride	0	100	0	60	X	X	O	O	—

(1) Maintain a velocity of < 10 ft/sec (3 m/sec).

## 7.13 M chemical tables

Table 7-13: Synonyms for M chemicals

Synonym	Listed under
2-methylactonitrile	Acetone cyanohydrin

**Table 7-13: Synonyms for M chemicals (continued)**

Synonym	Listed under
MDEA	Methyldiethanolamine
Methanal	Formaldehyde
Methanecarboxylic acid	Acetic acid
Methanoic acid	Formic acid
Methanol	Methyl alcohol
Methyl benzene	Toluene
Methyl cyanide	Acetonitrile
Methyltrichlorosilane	Methyldichlorosilane
Morkit	Anthraquinone
MTBE	Methyl Tert Butyl Ether
Muriatic acid	Hydrochloric acid

### 7.13.1 M chemicals with Coriolis meters

Chemical	Temp °C		Conc. % wt		SS	C22	Ta	Ti
	Low	High	Low	High				
Magnesium chloride	0	120	0	100	X	O	O	O
	120	153	50	100	X	O	O	—
Magnesium hydroxide	0	100	0	100	O	O	O	O
	100	120	0	100	—	—	—	—
Magnesium nitrate	0	93	0	100	O <sup>(1)</sup>	O	O	O
Magnesium oxide					O <sup>(2)</sup>	O	O	O
Magnesium silicate					O	O	—	—
Magnesium sulfate	0	93	0	50	—	O	O	O
Magnetic slurries					—	O	O	X
Maleic acid	0	80	0	100	O	O	O	O
	80	120	0	100	X	—	—	O
Maleic anhydride					O	O	O	O
Malumar					O	O	—	—
Manganese cobalt acetate					O	O	—	—
Manganese sulfate	0	63	0	100	—	O	O	O
Mayonnaise					O	O	O	O
Mercaptan					O	O	O	—
Mercapto ethanol					O	O	—	—
Methacrylic acid	0	100			O	O	O	—
Methane					O	O	O	O
Methane sulfonic acid					X	O <sup>(3)</sup>	O	X

Chemical	Temp °C		Conc. % wt		SS	C22	Ta	Ti
	Low	High	Low	High				
Methanol	0	100	0	100	O	O	O	X
Methyl acetate	0	60	0	60	O	O	—	—
Methyl acrylate					O	O	O	—
Methyl alcohol	0	100	0	100	O	O	O	X
Methyl benzimidazole zinc salt					—	O	O	—
Methyl bromide	0	20	0	100	O	—	O	O
	20	120	0	100	—	—	—	—
Methyl chloride	0	104	0	100	X	O	O	O
Methyl chloride (anhydrous)	0	120	100	100	O	O	O	O
Methyl ethyl ketone	0	93	0	100	O	O	O	O
Methyl iodide					X	—	O	X
Methyl methacrylate					O	O	O	—
Methyl sulfonic acid					X	O <sup>(3)</sup>	O	X
Methyl tert butyl ether					O	—	—	—
Methylamine					O	—	O	X
Methyldichlorosilane					X	O	O	—
Methyldiethanolamine	0	100			O	O	—	—
Methylene chloride (anhydrous)	0	59			O	O	O	X
Methylene chloride	0	30	0	100	X	O	O	X
	0	120	0	100	X	X	O	X
Methyltrichlorosilane					X	O	—	—
Methylpyrrolidone					O	O	—	—
Methylstyrene					O	O	O	—
Mineral oil					O	O	O	O
Mineral spirits					O	O	O	—
Molasses					C	O	O	O
Monochlorobenzene					X	O	O	X
Monochlorodifluoromethane					O	O	O	—
Mono-ethanolamine hydrochloride	0	65	0	100	—	O	O	—
Mono-ethanolamine	0	100	0	100	O	O	O	O
Morpholine					O	O	X	—

Chemical	Temp °C		Conc. % wt		SS	C22	Ta	Ti
	Low	High	Low	High				
Musk concentrate					O	O	—	—
Mustard gas					X	—	O	—

- (1) 304L included
- (2) Check for chlorides.
- (3) Maintain a velocity of < 10 ft/sec (3 m/sec).

## 7.13.2 M chemicals with fork density and viscosity meters

Chemical	Temp °C		Conc. % wt		316L	304L	C22	Ti	Zr
	Low	High	Low	High					
Magnesium chloride	0	120	0	100	X	X	O	O	—
	120	153	50	100	X	X	O	—	—
Magnesium hydroxide	0	100	0	100	O	—	O	O	—
	100	120	0	100	—	—	—	—	—
Magnesium nitrate	0	93	0	100	O	O	O	O	—
Magnesium oxide					O	—	O	O	—
Magnesium silicate					O	—	O	—	—
Magnesium sulfate	0	93	0	50	O	O	O	O	O
	0	100	50	100	—	—	O	O	—
Magnetic slurries					—	—	O	—	—
Maleic acid	0	80	0	100	O	—	O	O	—
	80	120	0	100	—	—	—	O	—
Maleic anhydride					O	—	O	O	—
Manganese cobalt acetate					O	—	O	—	—
Manganese sulfate	0	63	0	100	O	X	O	O	—
Mayonnaise					O	—	O	O	—
Mercaptan					O	—	O	—	—
Mercapto ethanol					O	—	O	—	—
Methacrylic acid					O	—	O	—	—
Methane					O	—	O	O	—
Methanol	0	100	0	100	O	O	O	X	O
Methyl acetate	0	60	0	60	O	O	O	—	—
Methyl acrylate					O	—	O	—	—
Methyl alcohol	0	100	0	100	O	O	O	X	O
Methyl benzimidazole zinc salt					—	—	O	—	—
Methyl bromide	0	20	0	100	O	—	O	O	—
	20	120	0	100	—	—	O	—	—

Chemical	Temp °C		Conc. % wt		316L	304L	C22	Ti	Zr
	Low	High	Low	High					
Methyl chloride (dry)	0	59	0	100	O	X	O	X	—
Methyl chloride	0	104	0	100	X	X	O	O	—
Methyl ethyl ketone	0	93	0	100	O	—	O	O	—
Methyl iodide					X	X	O	X	—
Methyl methacrylate					O	—	O	—	—
Methylsulfonic acid					X	X	O	X	—
Methylamine					O	X	O	X	—
Methyldichlorosilane					—	—	O	—	—
Methylene chloride (dry)					O	X	O	X	—
Methylene chloride	0	30	0	100	—	X	O	X	—
	0	120	0	100	—	X	—	X	—
Methylpyrrolidone					O	—	O	—	—
Mineral oil					O	—	O	O	—
Mineral spirits					O	—	O	—	—
Molasses					O	—	O	O	—
Monochlorobenzene					—	—	O	—	—
Monochlorodifluoromethane					O	—	O	O	—
Monoethanoamine hydrochloride	0	65	0	100	—	X	O	—	—
Monoethanolamine	0	100	0	90	O	—	O	O	—
Morpholine					O	X	C	—	—
Musk concentrate					O	—	O	—	—

## 7.14 N chemical tables

Table 7-14: Synonyms for N chemicals

Synonym	Listed under
N	Nitrogen
NCI-c56326	Acetaldehyde
Nitrobenzol	Nitrobenzene
Nordhausen acid (DOT)	Sulfuric acid

### 7.14.1 N chemicals with Coriolis meters

Chemical	Temp °C		Conc. % wt		SS	C22	Ta	Ti
	Low	High	Low	High				
Nadir methyl anhydride					O	O	—	—
Nalco 625					—	O	—	—
Naphtha					O	O	O	O
Naphthalene	0	120	0	100	O	O	O	O
Naphthalene sulfonic acid	0	200	0	100	—	O <sup>(1)</sup>	O	—
Neopentyl glycol					—	O	—	—
Nickel chloride	0	90	0	100	X	O	O	O
Nickel slurry					O	O	—	—
Nickel sulfate					X	O	—	—
Nitric acid	-18	10	0	75	O <sup>(2)</sup>	O	O	O
	-18	10	75	100	O <sup>(2)</sup>	O	O	O
	10	24	0	70	O <sup>(2)</sup>	X	O	O
	10	24	70	100	O <sup>(2)</sup>	X	O	X
	24	38	0	20	O <sup>(2)</sup>	O	O	O
	24	38	20	50	O <sup>(2)</sup>	X	O	O
	24	38	50	70	X <sup>(2)</sup>	X	O	X
	24	38	70	90	X <sup>(2)</sup>	X	O	X
	24	38	90	100	X <sup>(3)</sup>	X	O	X
	38	52	0	10	O <sup>(2)</sup>	O	O	O
	38	52	10	40	O <sup>(2)</sup>	X	O	O
	38	52	40	70	X <sup>(4)</sup>	X	O	X
	38	52	70	80	X <sup>(4)</sup>	X	O	X
	38	52	80	100	X <sup>(3)</sup>	X	O	X
	52	66	0	30	O <sup>(2)</sup>	X	O	X
	52	66	30	70	X <sup>(4)</sup>	X	O	X
	52	66	70	100	X <sup>(3)</sup>	X	O	X
	66	80	0	20	O <sup>(2)</sup>	X	O	X
	66	80	20	45	X <sup>(2)</sup>	X	O	X
	66	80	45	55	X <sup>(4)</sup>	X	O	X
66	80	55	100	X <sup>(3)</sup>	X	O	X	
80	93	0	45	X <sup>(3)</sup>	X	O	X	
80	93	45	100	X <sup>(3)</sup>	X	O	X	
93	163	0	100	X <sup>(3)</sup>	X	O	X	
Nitroaniline					X	O	O	—

Chemical	Temp °C		Conc. % wt		SS	C22	Ta	Ti
	Low	High	Low	High				
Nitrobenzene					O	O	O	O
Nitrochlorobenzene					X	O	O	—
Nitrogen					O	O	O	O
Nitrous oxide					O	O	—	X
Nonanoic acid					O	O	O	—
Nonyl phenol					O	O	O	—

- (1) Maintain a velocity of < 10 ft/sec (3 m/sec).
- (2) 304L = O
- (3) 304L = X
- (4) 304L = C

### 7.14.2 N chemicals with fork density and viscosity meters

Chemical	Temp °C		Conc. % wt		316L	304L	C22	Ti	Zr
	Low	High	Low	High					
Nadir methyl anhydride					O	—	O	—	—
Nalco 625					—	—	O	—	—
Naphtha					O	—	O	—	—
Naphthalene	0	120	0	100	O	—	O	—	—
Naphthalene sulfonic acid	0	200	0	100	X	X	O	X	—
Neopentyl glycol					—	—	O	—	—
Nickel chloride	0	90	0	100	X	X	O	O	—
Nickel slurry					O	—	O	—	—
Nitric acid	-18	10	0	75	O	O	O	O	O
	-18	10	75	100	O	O	O	X	O
	10	24	0	70	O	O	X	X	O
	10	24	70	90	O	O	X	X	O
	10	24	90	100	O	O	X	X	X
	24	38	0	20	O	O	O	O	O
	24	38	20	50	O	O	X	X	O
	24	38	50	90	X	O	X	X	O
	24	38	90	100	X	C	X	X	X
	38	52	0	10	O	O	O	O	O
	38	52	10	40	O	O	X	X	O
	38	52	40	80	X	O	X	X	O
	38	52	80	90	X	C	X	X	O
	38	52	90	100	X	C	X	X	X

Chemical	Temp °C		Conc. % wt		316L	304L	C22	Ti	Zr
	Low	High	Low	High					
	52	66	0	30	O	O	O	X	O
	52	66	30	70	X	O	O	X	O
	52	66	70	90	X	C	X	X	O
	52	66	90	100	X	C	X	X	X
	66	80	0	20	X	O	X	X	O
	66	80	20	45	X	C	X	X	O
	66	80	45	55	X	C	X	X	O
	66	80	55	100	X	X	X	X	O
	80	93	0	45	X	X	X	X	O
	80	93	45	100	X	X	X	X	O
	93	140	0	90	X	X	X	X	O
Nitroaniline					X	X	O	—	—
Nitrobenzene					O	—	O	O	—
Nitrochlorobenzene					X	X	O	—	—
Nitrogen					O	—	O	O	—
Nonanoic acid sludge					O	—	O	—	—
Nonyl phenol					O	—	O	—	—

## 7.15 O chemical tables

Table 7-15: Synonyms for O chemicals

Synonym	Listed under
Oil of mirbane	Nitrobenzene
Oil of vitriol	Sulfuric acid
Opadry	Hydroxypropylmethylcellulose
Oxyacetylene	Acetylene
Oxybisethanol	Diethylene glycol

### 7.15.1 O chemicals with Coriolis meters

Chemical	Temp °C		Conc. % wt		SS	C22	Ta	Ti
	Low	High	Low	High				
Octanol					O	O	—	—
Oil, crude					C	O	O	C
Oil, fuel					C	O	O	C
Oil, hydraulic cylinder					O	O	O	O
Oil, lube					O	O	O	O

Chemical	Temp °C		Conc. % wt		SS	C22	Ta	Ti
	Low	High	Low	High				
Oil, soybean					O	O	O	O
Oil, spindle					O	O	O	O
Oil, turpentine					O	O	O	O
Oil, vegetable	0	43	0	100	O	O	O	O
	43	104	0	100	O	O	O	—
Oleum	-18	20	100		O <sup>(1)</sup>	O	O	X
	20	60	100		O <sup>(1)</sup>	C	X	X
Orange juice					O	O	O	O
Oxalic acid	0	104	0	10	X	O	O	X
Oxygen					C	C	O	X
Ozonated water					O	—	—	O
Ozone					O	O	—	O

(1) 304L = O; 10 ft/sec (3 m/sec) maximum for all SS types

## 7.15.2 O chemicals with fork density and viscosity meters

Chemical	Temp °C		Conc. % wt		316L	304L	C22	Ti	Zr
	Low	High	Low	High					
Octanol					O	—	O	—	—
Oil, crude					C	X	O	—	—
Oil, fuel					C	X	O	—	—
Oil, hydraulic cylinder					O	—	O	O	—
Oil, lube					O	—	O	O	—
Oil, soybean					O	—	O	O	—
Oil, spindle					O	—	O	O	—
Oil, transformer					O	—	O	—	—
Oil, turpentine					O	—	O	O	—
Oil, vegetable	0	43	0	100	O	—	O	O	—
	43	104	0	100	O	—	O	—	—
Oil, waste					—	—	O	—	—
Oleum	20	50	0	100	O	O	—	—	—
Orange juice					O	—	O	O	—
Oxalic acid	0	104	0	10	—	—	O	X	O
Oxygen					O	O	O	X	—
Ozonated water					O	—	—	O	—

## 7.16 P chemical tables

Table 7-16: Synonyms for P chemicals

Synonym	Listed under
1, 3 - Phthalandione	Phthalic anhydride
2 - Propenoic acid	Acrylic acid
Pentanethiol	Amyl mercaptan
Perchlorocyclopentadiene	Hexachlorocyclopentadiene
Phenyl amine	Aniline
Phenyl chloride	Chlorobenzene
Phenyl ethylene	Styrene
Phthalic acid anhydride	Phthalic anhydride
Potash, caustic	Potassium hydroxide
Propanoic acid	Propionic acid
Propanol	Propyl alcohol
Propanone	Acetone
Propenonitrile	Acrylonitrile
Propenyl alcohol	Allyl alcohol
P-toluenesulphonic acid, p-toluene sulphonic acid	Alkylbenzene sulfonic acid

### 7.16.1 P chemicals with Coriolis meters

Chemical	Temp °C		Conc. % wt		SS	C22	Ta	Ti
	Low	High	Low	High				
Paint					O	O	O	—
Palmitic acid					O	—	—	—
Paraffin					O	O	O	O
Paranitrochlorinebenzene					X	—	O	—
Pentamethyl indan					O	O	—	—
Pentane					O	O	O	O
Peracetic acid	0	38	0	35	O	O	X	X
Perchloro- ethylene (anhydrous)	0	120	100	100	O	O	—	—
Perchloro- ethylene	0	120	0	100	X	O	—	—
Perfluorochemical inert liquid					X	—	—	X
Peroxide acid					—	O	—	—
Peroxyacetic acid	0	40			X	O	—	—
Petroleum gas (liquified)					O	O	O	O
Phenol	0	100	0	100	O <sup>(1)</sup>	O	O	X

Chemical	Temp °C		Conc. % wt		SS	C22	Ta	Ti
	Low	High	Low	High				
Phenol formaldehyde	0	130	0	100	O	O	O	X
Phenolsulfonic acid					X	O <sup>(2)</sup>	O	—
Phenothiazine					O	O	O	—
Phosgene	20	65	0	100	X	O	O	—
Phosphoric acid-food grade	0	25	0	80	O	O	O	X
Phosphoric acid	0	100	0	5	O	O	O	C
	0	65	5	95	X	O	O	X
	65	100	5	100	X	X	O <sup>(3)</sup>	X
Phosphorus, molten					X	O	O	X
Phosphorous acid					X	O	O	—
Phosphorous oxychloride					X	—	O	C
Phosphorous trichloride					X	X	O	O
Phthalic acid					O	O	O	O
Phthalic anhydride	-18	99	98	100	O	O	C	—
	99	149	98	100	X	O	C	—
	149	204	98	100	X	O	—	—
Phthalic anhydride/thermon					—	O	O	—
Picric acid					X	O	O	X
Pitch	100	200	0	100	O	—	O	O
Pivalic acid					O	O	—	—
Pivaloyl chloride	0	50			X	X	O	X
Platinum chloride					X	—	O	—
Polyacrylamide					O	O	—	—
Polyaluminum chloride	0	80	0	50	X	O	O	X
Polyamine	0	182	0	100	—	O	O	—
Polybutyl chloride					X	O	O	—
Polydimethylaminetetra-chlorohydrate					—	O	O	—
Polydimethylsiloxane	0	200	100	100	O	O	—	—
Polyester					O	O	O	—
Polyethylene					O	O	O	—
Polyethylene glycol					O	O	O	O
Polyethylene wax					O	O	—	O
Polyisobutylene					O	O	—	—

Chemical	Temp °C		Conc. % wt		SS	C22	Ta	Ti
	Low	High	Low	High				
Polyol					O	O	—	—
Polyphosphoric acid	0	100	105	118	O	O	O	X
Polyphosphorous					X	O	O	—
Polyvinyl alcohol					O	O	O	—
Potassium acetate					—	—	—	—
Potassium bisulfite	0	63	0	100	—	O	O	—
Potassium bromide	0	31	0	30	X	O	O	O
	0	104	30	50	X	X	—	O
	0	104	50	100	—	—	—	O
Potassium carbonate	0	100	0	20	O	O	X	O
	0	100	20	90	X	O	X	O
Potassium chloride	0	110	0	99	X	O	O	O
	0	160	0	99	X	X	O	O
Potassium chromate	0	24	0	10	X	O	O	—
Potassium hydroxide	0	93	0	40	O	O	X	X
	0	100	40	50	X	O	X	X
Potassium iodide					C	O	O	O
Potassium nitrate	0	100			X	O	O	O
Potassium permanganate	0	100	0	50	X	O	O	O
Potassium persulfate	0	24	0	4	X	O	O	—
Primary stearyl amine					O	O	—	—
Propane					O	O	O	O
Propionic acid	0	50	0	97	O	O	O	—
	50	140	0	97	—	O	O	—
Propyl alcohol	0	104	0	100	O	O	O	O
Propylene					O	O	O	O
Propylene glycol					O	O	O	O
Propylene oxide					O	O	O	—
Pyridine					O	C	O	X
Pyridine hydrochloride					X	C	O	C

- (1) 304L = X
- (2) Maintain a velocity < 10 ft/sec (3 m/sec).
- (3) Low fluoride

## 7.16.2 P chemicals with fork density and viscosity meters

Chemical	Temp °C		Conc. % wt		316L	304L	C22	Ti	Zr
	Low	High	Low	High					
Paint					O	—	O	O	—
Palmitic acid					O	X	O	—	—
Paper pulp (chlorine bleached)	0	74	0	15	—	—	O	O	—
Paraffin					O	—	O	O	—
Paranitrochlorinebenzene					X	X	—	—	—
Pentamethyl indan					O	—	O	—	—
Pentane					O	—	O	O	—
Perchloroethylene (anhydrous)					O	—	O	—	—
Perchloroethylene (wet)					X	X	O	—	—
Perfluorochemical inert liquid					—	X	O	—	—
Peroxide acid					—	—	O	—	—
Phenol	0	100	0	95	O	X	O	X	O
Phenol formaldehyde	0	130	0	100	O	—	O	X	—
Phenolsulfonic acid					X	X	O	X	—
Phenothiazine					O	—	O	—	—
Phosgene	20	65	0	100	—	—	O	—	—
Phosphoric acid Food grade (thermal process)	0	25	0	85	O	—	O	—	—
Phosphoric acid Wet chemical process acid	0	100	0	5	O	X	O	X	O
	0	65	5	95	C	X	O	X	X
	65	100	5	100	X	X	C	X	X
Phosphorous					—	X	O	—	—
Phosphorous acid					—	—	O	—	—
Phosphorous oxychloride	0	80			X	X	O	C	—
Phosphorous trichloride					X	X	O	C	—
Phthalic acid					O	—	O	—	—
Phthalic anhydride	-18	99	98	100	O	O	O	O	—
	99	149	98	100	X	X	O	O	—
	149	204	98	100	X	X	O	—	—
Phthalic anhydride/thermon					—	—	O	—	—
Picric acid					X	X	O	X	—
Pitch	100	200	0	100	O	—	O	O	—

Chemical	Temp °C		Conc. % wt		316L	304L	C22	Ti	Zr
	Low	High	Low	High					
Pivalic acid					O	—	O	—	—
Platinum chloride					X	X	O	—	—
Polyacrylamide					O	—	O	—	—
Polyamine	0	182	0	100	—	—	O	—	—
Polybutyl chloride					X	X	O	—	—
Polydimethylaminetetra-chlorohydrate					X	X	O	—	—
Polyester					O	—	O	—	—
Polyethylene					O	—	O	—	—
Polyethylene glycol					O	—	O	—	—
Polyethylene wax					O	—	O	O	—
Polyisobutylene					O	—	O	—	—
Polyol					O	—	O	—	—
Polyphosphorous					X	X	O	—	—
Polyvinyl alcohol					O	—	O	—	—
Potassium acetate					—	—	O	—	—
Potassium bisulfite	0	63	0	100	—	—	O	—	—
Potassium bromide	0	31	0	30	X	X	O	O	O
	0	104	30	50	X	X	—	O	O
	0	104	50	100	X	X	—	O	—
Potassium carbonate	0	100	0	20	O	O	O	O	—
	0	100	20	90	—	X	O	O	—
Potassium chloride	0	110	0	99	X	X	O	O	O
	110	160	0	99	X	X	C	O	O
Potassium chromate	0	24	0	10	—	—	O	O	O
Potassium hydroxide	0	93	0	40	O	—	O	C	O
	0	100	40	50	X	X	O	C	O
Potassium iodide					C	X	O	O	O
Potassium nitrate	0	100	0	90	—	—	O	O	O
Potassium permanganate	0	100	0	50	C	X	C	O	—
Potassium persulfate	0	24	0	4	O	—	O	—	—
Primary stearyl amine					O	—	O	—	—
Propane					O	—	O	O	—

Chemical	Temp °C		Conc. % wt		316L	304L	C22	Ti	Zr
	Low	High	Low	High					
Propionic acid	0	70	0	97	O	O	O	X	—
	0	140	0	97	X	X	O	X	—
Propyl alcohol	0	104	0	100	O	—	O	O	—
Propylene					O	—	O	O	—
Propylene glycol					O	—	O	O	—
Propylene oxide					O	—	O	—	—
Pyridine	0	100			O	O	C	X	—
Pyridine hydrochloride	0	100			X	X	C	X	—

## 7.17 Q chemical tables

Table 7-17: Synonyms for Q chemicals

Synonym	Listed under
Quartz	Silicon dioxide

### 7.17.1 Q chemicals with Coriolis meters

Chemical	SS	C22	Ta	Ti
Quaternary ammonium chloride	X	O	X	—

### 7.17.2 Q chemicals with fork density and viscosity meters

Chemical	316L	304L	C22	Ti	Zr
Quaternary ammonium chloride	X	X	O	—	—

## 7.18 R chemical tables

### 7.18.1 R chemicals with Coriolis meters

Chemical	Temp °C		Conc. % wt		SS	C22	Ta	Ti
	Low	High	Low	High				
Red liquor	0	120			X	O	—	—
Rhodium					O	O	O	—
Rosin	0	200	0	100	—	O	O	—
Roundup herbicide					X	O	O	X
Rubber cement					O	O	—	—
Rubber hydrocarbon					O	O	—	—

## 7.18.2 R chemicals with fork density and viscosity meters

Chemical	Temp °C		Conc. % wt		316L	304L	C22	Ti	Zr
	Low	High	Low	High					
Red liquor					X	X	O	—	—
Rosin	0	200	0	100	—	—	O	—	—
Roundup herbicide					X	X	O	—	—
Rubber cement					O	—	O	—	—
Rubber hydrocarbon					O	—	O	—	—

## 7.19 S chemical tables

Table 7-18: Synonyms for S chemicals

Synonym	Listed under
Saline solution	Sodium chloride
Salmiac	Ammonium chloride
Salt, salt brine, salt water	Sodium chloride
Sea water	Brine
Soda, caustic	Sodium hydroxide
Soda ash	Sodium carbonate
Spindle oil	Oil, spindle
Sugar of lead	Lead acetate
Sulfonic acid, sulphonic acid	Alkylbenzene sulfonic acid and alkylsulfonic acid
Sulfuric acid, fuming	Oleum
Sulfurous acid	Sulphurous acid
Sulphuric acid	Sulfuric acid

### 7.19.1 S chemicals with Coriolis meters

Chemical	Temp °C		Conc. % wt		SS	C22	Ta	Ti
	Low	High	Low	High				
Safety-kleen 105					O	O	O	—
Salicylic acid	0	120	0	100	X	O	O	O
Scalp oil					X	O	O	O
Seawater					X	O	O	O
Sebacic acid	0	104	0	10	—	O	O	—
Sentol (liquid acid cleaner)					—	O	O	—
Silane	0	80	100	100	O	O	—	—
Silica slurry					O	O	O	—
Silicon dioxide					O	O	O	—
Silicon tetrachloride slurry					O	O	O	X
Silicon tetrafluoride					X	—	O	—
Silicon trichloride					O	O	O	X
Silicone					O	O	O	O
Silicone oil					O	O	O	O
Siloxanes <sup>(1)</sup>					C	C	O	C
Silver nitrate					O	O	O	O
Soap fat	0	200	0	100	—	O	O	O
Soap solution					O	O	O	O

Chemical	Temp °C		Conc. % wt		SS	C22	Ta	Ti
	Low	High	Low	High				
Sodium alkyl glyceryl sulfonate					—	O	—	—
Sodium aluminate					O	O	—	O
Sodium bicarbonate			0	20	O	O	O	O
			20	100	—	—	O	O
Sodium bisulfate	0	82	0	20	X	O	O	C
Sodium bisulfide	0	60	0	12	O	O	X	O
	0	93	12	60	X	C	X	—
Sodium bisulfite	0	60	0	30	X	O	O	O
Sodium carbonate	0	100	0	100	O	O	X	O
Sodium chlorate	0	150	0	100	X	O	O	O
Sodium chloride	0	90	0	100	X	O	O	O
Sodium chlorite	0	35	0	50	X	O	X	O
Sodium citrate			0	38	O	X	O	O
Sodium cyanide	0	38	0	10	O	O	—	O
	0	120	0	100	X	X	—	—
Sodium formaldehyde					O	O	O	—
Sodium formaldehyde bisulfate					O	O	O	—
Sodium formaldehyde sulfoxylate					—	O	O	—
Sodium formate	0	100	0	50	O	O	—	X
Sodium gluconate					O	O	—	—
Sodium hydrosulfate	0	82	0	20	X	O	O	O
Sodium hydrosulfide	0	60	0	12	O	O	X	O
	0	93	12	60	X	C	X	—
Sodium hydrosulfite	0	50	0	40	O	O	X	O
Sodium hydroxide <sup>(2)</sup>	0	53	0	15	O	O	X	C
	0	53	15	20	O	O	X	X
	0	53	20	50	X	O	X	X
	53	86	0	50	X	O	X	X
	86	120	0	100	X	X	X	X
Sodium hypochlorite	0	60	0	16	X	O <sup>(3)</sup>	O	O <sup>(3)</sup>
	60	80	16	20	X	X	O	O <sup>(3)</sup>
Sodium hypophosphite					O	O	O	—
Sodium laureth sulfate	0	38	0	70	O	—	—	—

Chemical	Temp °C		Conc. % wt		SS	C22	Ta	Ti
	Low	High	Low	High				
Sodium lauryl sulfate	0	38	0	70	O	O	—	—
Sodium metabisulfite					—	O	—	—
Sodium metal					X	O	O	O
Sodium methoxide	0	90	0	30	X	O	X	X
Sodium methylate	0	90	0	30	X	O	X	X
Sodium nitrate	0	100	0	60	O	O	O	O
	0	120	60	100	—	—	—	O
Sodium nitrite					X	O	O	O
Sodium omadine					X	O	—	O
Sodium perchlorate	0	65	0	100	—	O	O	—
Sodium persulfate					X	O	O	—
Sodium phenolate	0	120	0	100	—	O	O	—
Sodium phosphate			0	100	X	O	C	O
Sodium polyphosphate					—	O	—	—
Sodium silicate					O	O	O	O
Sodium sulfate	0	100	0	20	O	O	O	O
Sodium sulfide	0	120	0	50	X	O	O	O
Sodium sulfite	0	60	0	10	O	O	O	O
	60	120	0	10	X	O	O	O
Sodium thiosulfate	0	38	0	30	O	O	—	O
Sodium xylene sulphonate					O	O	O	—
Soy oil					O	O	O	O
Soy protein			0	18	—	O	O	O
Soy sauce					X	O	O	O
Stannic chloride					X	O	O	O
Stannous chloride	0	75	0	10	X	O	O	O
	0	120	10	100	X	O	O	—
Starch syrup					O	O	O	—
Stearic acid					O	O	O	O
Styrene					O	O	O	—
Sucrose	0	93	0	62	O	O	O	—
Sulfamic acid	0	30			O	O	O	X
Sulfanilic acid					O	O	—	—
Sulfite liquor					X	O	X	O
Sulfolane					O	O	O	—

Chemical	Temp °C		Conc. % wt		SS	C22	Ta	Ti
	Low	High	Low	High				
Sulfonic acid					C <sup>(4)</sup>	O	O	X
Sulfonylchloride					X	O	O	—
Sulfur, molten	0	160	0	100	O <sup>(5)</sup>	O	O	O
Sulfur dichloride					X	O	O	—
Sulfur dioxide (anhydrous)					O	O	O	O
Sulfur dioxide (wet)					X	O	O	X
Sulfur hexafluoride					O	O	—	—
Sulfur monochloride					X	—	O	—
Sulfur tetrafluoride					X	X	X	X
Sulfur trioxide	0	25	0	100	—	O	X	X
Sulfuric acid	-18	0	0	20	O <sup>(4)</sup>	O <sup>(4)</sup>	O	X
	-18	0	20	65	X	O <sup>(4)</sup>	O	X
	-18	0	65	75	X	X	O	X
	-18	0	75	85	X	O <sup>(6)</sup>	O	X
	-18	0	85	93	—	O <sup>(4)</sup>	O	X
	-18	0	93	100	O <sup>(4)</sup>	O <sup>(4)</sup>	O	X
	0	24	0	20	O <sup>(4)</sup>	O <sup>(4)</sup>	O	X
	0	24	20	65	X	C <sup>(6)</sup>	O	X
	0	24	65	75	X	X	O	X
	0	24	75	85	X	O <sup>(7)</sup>	O	X
	0	24	85	93	X	O <sup>(6)</sup>	O	X
	0	24	93	98	O <sup>(6)</sup>	O <sup>(6)</sup>	O	X
	0	24	98	100	O <sup>(4)</sup>	O <sup>(4)</sup>	O	X
	24	38	0	10	O <sup>(4)</sup>	O <sup>(4)</sup>	O	X
	24	38	10	40	X	C <sup>(4)</sup>	O	X
	24	38	40	75	X	X	O	X
	24	38	75	85	—	—	O	X
	24	38	85	93	X	O <sup>(6)</sup>	O	X
	24	38	93	98	O <sup>(7)</sup>	O <sup>(7)</sup>	O	X
	24	38	98	100	O <sup>(4)</sup>	O <sup>(4)</sup>	O	X
38	52	0	5	O <sup>(4)</sup>	O <sup>(4)</sup>	O	X	
38	52	5	25	X	O <sup>(4)</sup>	O	X	
38	52	25	75	X	X	O	X	
38	52	75	90	X	—	O	X	
38	52	90	98	—	O <sup>(6)</sup>	O	X	
38	52	98	100	— <sup>(4)(8)</sup>	C <sup>(4)</sup>	O	X	

Chemical	Temp °C		Conc. % wt		SS	C22	Ta	Ti
	Low	High	Low	High				
	52	54	0	5	X	O <sup>(4)</sup>	O	X
	52	54	5	75	X	X	O	X
	52	54	75	98	—	—	O	X
	52	54	98	100	— <sup>(8)(9)</sup>	—	O	X
	54	66	0	5	X	O <sup>(9)</sup>	O	X
	54	66	5	98	X	X	O	X
	54	66	98	100	X	X	X	X
	66	93	0	50	X	X	O	X
	66	93	50	98	X	X	O	X
	66	93	98	100	X	X	X	X
93	204	0	100	X	X	X	X	
Sulfuryl fluoride					X	—	—	—
Sulfuryl chloride					X	X	O	—
Sulphurous acid					X	O	O	—
Syrups (water, flour, starch, and corn)					—	O	O	O

- (1) Check for HCl contamination.
- (2) Observe the chloride limits shown in *Halogens*.
- (3) No C22 or Ti with hypochlorite generators (e.g. 0.8% concentration).
- (4) Maintain a velocity of < 10 ft/sec (3 m/sec).
- (5) Avoid H<sub>2</sub>O and H<sub>2</sub>S with 316L.
- (6) Maintain a velocity of < 5 ft/sec (1.5m/sec).
- (7) Maintain a velocity of < 4 ft/sec (1.2 m/sec).
- (8) 304L = 0
- (9) Maintain a velocity of < 2 ft (0.6 m/sec).

## 7.19.2 S chemicals with fork density and viscosity meters

Chemical	Temp °C		Conc. % wt		316L	304L	C22	Ti	Zr
	Low	High	Low	High					
Safety-kleen 105					O	O	O	—	—
Salicylic acid	0	120	0	100	X	X	O	O	—
Scalp oil					X	X	O	O	—
Seawater					X	X	O	O	O
Sebacic acid	0	104	0	10	—	—	O	O	—
Sentol (liquid acid cleaner)					—	—	O	—	—
Silica slurry					O	—	O	—	—
Silicon dioxide					O	—	O	—	—
Silicone					O	—	O	O	—
Silicone oil					O	—	O	O	—

Chemical	Temp °C		Conc. % wt		316L	304L	C22	Ti	Zr
	Low	High	Low	High					
Silicontetrachloride slurry					O	—	O	—	—
Silver nitrate					X	X	O	—	—
Soap Fat	0	200	0	100	—	—	O	—	—
Soap solution					O	—	O	O	—
Sodium alkyl glyceryl sulfonate					—	—	O	—	—
Sodium aluminate	0	100	0	25	O	—	—	O	—
Sodium bicarbonate	0	120	0	20	O	O	—	O	O
	0	65	20	100	O	O	O	O	—
Sodium bisulfate	0	82	0	20	X	X	O	—	—
Sodium bisulfide	0	60	0	12	O	—	O	O	—
	0	93	12	60	X	X	C	—	—
Sodium bisulfite					X	X	O	O	—
Sodium carbonate	0	100	0	100	O	O	O	O	O
Sodium chlorate	0	104	0	70	X	X	O	O	O
	60	150	70	100	X <sup>(1)</sup>	X	O	—	—
Sodium chloride	0	90	0	100	C	X	O	O	O
Sodium chlorite	0	35	0	50	X	X	O	O	—
Sodium citrate	0	60	0	38	—	O	X	O	—
Sodium cyanide	0	38	0	10	O	—	O	O	—
	0	100	0	100	—	—	O	O	—
Sodium formaldehyde					O	—	O	—	—
Sodium formaldehyde bisulfate					O	—	O	—	—
Sodium formaldehyde sulfoxylate					—	—	O	—	—
Sodium formate	0	100	0	50	O	—	O	X	—
Sodium gluconate					O	—	O	—	—
Sodium hydrosulfate	0	82	0	20	X	X	O	O	—
Sodium hydrosulfide	0	60	0	12	O	—	O	O	—
	0	93	12	60	X	X	C	—	—
Sodium hydrosulfite	0	50	0	40	O	—	O	—	—

Chemical	Temp °C		Conc. % wt		316L	304L	C22	Ti	Zr
	Low	High	Low	High					
Sodium hydroxide	0	53	0	15	O <sup>(1)</sup>	X	O	O	O
	0	53	15	20	O <sup>(1)</sup>	X	O	O	O
	0	53	20	50	O <sup>(1)</sup>	X	O	C	O
	53	86	0	50	X	X	O	X	O
	86	120	0	100	X	X	C	X	X
Sodium hypochlorite	0	60	0	16	X	X	O	O	O
	60	80	16	20	X	X	X	O	X
Sodium hypophosphite					O	—	O	—	—
Sodium laureth sulfate	0	38	0	70	O	—	—	—	—
Sodium lauryl sulfate	0	38	0	70	O	—	O	—	—
Sodium metabisulfite					—	—	O	—	—
Sodium metal					—	—	O	—	—
Sodium methoxide	0	90	0	30	X	X	O	X	—
Sodium methylate	0	90	0	30	X	X	O	X	—
Sodium nitrate	0	112	0	60	O	O	O	O	—
	0	120	60	100	O	—	—	O	—
Sodium nitrite					—	—	O	O	—
Sodium omandine					—	—	O	O	—
Sodium perchlorate	0	65	0	100	X	X	O	O	—
Sodium persulfate					X	X	O	—	—
Sodium phenolate	0	120	0	100	—	—	O	—	—
Sodium phosphate	0	100			X	X	O	O	—
Sodium polyphosphate					—	—	O	—	—
Sodium silicate					O	—	C	O	O
Sodium sulfate	0	100	0	20	O	O	O	O	O
Sodium sulfide	0	100	0	50	X	X	O	O	O
Sodium sulfite	0	60	0	10	O	O	O	O	—
	60	120	0	10	X	X	O	O	—
Sodium thiosulfate	0	38	0	30	O	—	O	O	—
Sodium xylene sulphonate					O	—	O	—	—
Soy oil					O	—	O	O	—

Chemical	Temp °C		Conc. % wt		316L	304L	C22	Ti	Zr
	Low	High	Low	High					
Soy protein			0	18	—	—	O	O	—
Soy sauce					—	—	O	O	—
Stannic chloride					X	X	X	O	—
Stannous chloride	0	75	0	10	X	X	O	O	O
	0	120	10	100	X	X	O	O	—
Starch syrup					O	—	O	—	—
Stearic acid					O	X	O	O	—
Styrene					O	—	O	—	—
Sucrose	0	93	0	62	O	—	O	—	—
Sulfamic acid	0	30			X	X	C	X	—
Sulfanilic acid					O	—	O	C	—
Sulfite liquor					X	X	O	X	—
Sulfolane					O	—	O	—	—
Sulfonic acid					X	X	O	X	—
Sulfonylchloride					X	X	O	X	—
Sulfur (molten)	0	120	0	100	O	—	O	—	—
Sulfur dichloride					X	X	O	X	—
Sulfur monochloride					X	X	O	X	—
Sulfuric acid	-18	24	0	20	O	X	O	X	O <sup>(2)</sup>
	-18	24	20	50	X	X	O	X	O <sup>(2)</sup>
	-18	24	50	75	X	X	O	X	X
	-18	24	75	85	X	X	O	X	X
	-18	24	85	93	X	X	O	X	X
	-18	24	93	98	O	X	O	X	X
	-18	24	98	100	O	O	C	X	X
	24	38	0	10	O	X	O	X	O <sup>(2)</sup>
	24	38	10	50	X	X	O	X	O <sup>(2)</sup>
	24	38	50	75	X	X	X	X	X
	24	38	75	85	X	X	X	X	X
	24	38	85	93	X	X	O	X	X
	24	38	93	98	O	X	O	X	X
	24	38	98	100	O	O	C	X	X
	38	52	0	5	O	X	O	X	O <sup>(2)</sup>
	38	52	5	25	X	X	O	X	O <sup>(2)</sup>
38	52	25	50	X	X	C	X	O <sup>(2)</sup>	
38	52	50	75	X	X	X	X	X	

Chemical	Temp °C		Conc. % wt		316L	304L	C22	Ti	Zr
	Low	High	Low	High					
	38	52	75	90	X	X	C	X	X
	38	52	90	98	X	X	O	X	X
	38	52	98	100	X	O	X	X	X
	52	54	0	5	O	X	O	X	O <sup>(2)</sup>
	52	54	5	10	X	X	O	X	O <sup>(2)</sup>
	52	54	10	50	X	X	X	X	O <sup>(2)</sup>
	52	54	50	85	X	X	X	X	X
	52	54	85	98	X	X	O	X	X
	52	54	98	100	X	O	X	X	X
	54	66	0	10	X	X	O	X	O <sup>(2)</sup>
	54	66	10	50	X	X	X	X	O <sup>(2)</sup>
	54	66	50	99	X	X	X	X	X
	54	66	99	100	X	O	X	X	X
	66	93	0	50	X	X	X	X	O <sup>(2)</sup>
	66	93	50	100	X	X	X	X	X
	93	204	0	100	X	X	X	X	C
Sulfuric fluoride					X	X	O	X	X
Sulfuryl chloride					X	X	C	X	C
Sulphurous acid					X	X	C	O	X

- (1) Observe the chloride limits shown in [Halogens](#).
- (2) Do not use Zr if oxidizing impurities such as ferric ions, cupric ions, or dissolved oxygen are present.

## 7.20 T chemical tables

Table 7-19: Synonyms for T chemicals

Synonym	Listed under
Table salt	Sodium chloride
Tallow	Animal fat
Tear gas	Chloropicrin
Tectilon blue	Anthraquinone
Tetrabromoethane, tetrabromoethane, tetrabromoacetylene	Acetylene tetrabromide
Tetrachloroethylene	Perchloroethylene
Tetrachloromethane	Carbon tetrachloride
Tetramethylene oxide	Tetrahydrofuran
Tin dichloride	Stannous chloride

**Table 7-19: Synonyms for T chemicals (continued)**

Synonym	Listed under
Tin tetrachloride	Stannic chloride
Toluol	Toluene
Transformer oil	Oil, transformer
Trichloroethylene, trichlorethylene, trichloroethene	Acetylene trichloride
Trichloromethane	Chloroform
Turpentine oil	Oil, turpentine

## 7.20.1 T chemicals with Coriolis meters

Chemical	Temp °C		Conc. % wt		SS	C22	Ta	Ti
	Low	High	Low	High				
Tall oil fatty acid					—	O	—	—
Tall oil rosin					—	O	O	—
Tall oil soap					X	O	X	—
Tar	150	200			O	O	O	X
Tar acid	0	200	0	100	X	O	O	—
Tea					O	O	O	O
Terephthalic acid	100	160	0	100	O <sup>(1)</sup>	O	O	—
Tetrachloro- ethane	0	70	0	100	X	O	O	O
Tetrachloro-ethylene	0	120	0	100	X	O	—	—
Tetrachloro-ethylene (anhydrous)	0	120	100	100	O	O	—	—
Tetrachloroethylene sulfide					X	O	—	—
Tetrachlorosilane					X	O	O	X
Tetrafluoroethane (anhydrous)					O	O	—	—
Tetrahydrofluorine					—	—	—	—
Tetrahydrofuran					O	O	—	X
Tetramethyl-ammonium hydroxide	0	60	0	35	X	O	X	—
Tetrasodium EDTA					O	O	—	—
Thinner					O	O	O	O
Thiodichloric acid					X	O	O	—
Thionyl chloride					X	X	O	X
Tin liquor					X	O	O	—
Titanium chloride	0	100			X	O	O	O

Chemical	Temp °C		Conc. % wt		SS	C22	Ta	Ti
	Low	High	Low	High				
Titanium dioxide					O	O	O	O
Titanium iron sulfate solution					—	—	—	—
Titanium oxychloride					X	X	O	X
Titanium tetrachloride	0	100			X	O	O	O
Toluene					O	O	O	O
Toluene diisocyanate					O	O	O	—
Toluene- sulfonic acid	0	125	0	94	X	O <sup>(2)</sup>	O	X
Tomato paste					O	O	—	—
Triacetin					O	O	—	—
Tribromomethane					X	—	O	—
Trichloroacetic acid	0	120	0	50	X	O	O	X
Trichloroacetyl chloride					X	X	O	—
Trichlorobenzene					X	O	O	—
Trichlorobromomethane					X	—	O	—
Trichloroethane					X	X	O	O
Trichloroethylene (anhydrous)					O	O	O	O
Trichloromethylpyridine					X	O	O	—
Trichloromonofluoroethane					O	O	—	—
Trichlorosilane (anhydrous)					O	O	O	X
Trichlorotrifluoroethane					O	O	—	X
Triethanol- amine	0	95	0	100	O	O	—	O
Triethyl aluminum					O	O	O	X
Triethylamine					O	O	O	—
Triethylene glycol					O	O	O	O
Trifluoroacetic acid					X	O	—	—
Trimethylchlorocyanate					X	O	O	—
Trimethyl sulfonium bromide					X	—	O	—
Triphenylmethylchloride					X	O	O	—
Triphenyl phosphite					O	O	O	O
Trisodium-phosphate	0	200	0	90	X	O	O	—
	0	60	0	50	O	O	O	—
Trityl chloride					X	O	O	—
Tungsten hexafluoride	0	50	100	100	X	O	—	—
Turpentine					O	O	O	X

- (1) Avoid bromides and chlorides.  
(2) Maintain a velocity of < 10 ft/sec (3 m/sec).

## 7.20.2 T chemicals with fork density and viscosity meters

Chemical	Temp °C		Conc. % wt		316L	304L	C22	Ti	Zr
	Low	High	Low	High					
Tall oil fatty acid					—	—	O	—	—
Tall oil rosin					—	—	O	—	—
Tall oil soap					—	—	O	—	—
Tar	150	200			O	—	O	—	—
Tar acid	0	200	0	100	—	—	O	—	—
Tea					O	—	O	O	—
Terephthalic acid	100	160	0	100	C	—	O	O	—
Tetrachloroethane	0	70	0	100	—	—	O	—	—
Tetrachloroethylene (anhydrous)					O	X	O	X	—
Tetrachloroethylene (wet)					X	X	O	X	—
Tetrachloroethylene sulfide					—	—	O	—	—
Tetrachlorosilane					—	—	O	—	—
Tetrafluoroethane (dry)					O	—	O	—	—
Tetrahydrofuran					O	—	O	X	—
Tetramethyl-ammonium hydroxide	0	60	0	35	—	—	O	—	—
Tetrasodium EDTA					O	—	O	—	—
Thinner					O	—	O	—	—
Thionyl chloride					X	X	O	X	—
Thiodichloric acid					—	—	O	—	—
Tin liquor					—	—	O	—	—
Titanium chloride	0	100			X	X	O	O	—
Titanium dioxide					O	—	O	O	—
Titanium iron sulfate solution					—	—	O	O	O
Titanium oxychloride					X	X	X	X	—
Titanium tetrachloride	0	100			X	X	O	O	—
Toluene					O	—	O	—	—
Toluene diisocyanate					O	—	O	—	—
Toluenesulfonic acid	0	125	0	94	X	X	O	X	—
Tomato paste					O	—	O	—	—
Triacetin					O	—	O	—	—
Tribromomethane					X	X	O	—	—
Trichloroacetic acid	0	120	0	50	X	X	O	X	X

Chemical	Temp °C		Conc. % wt		316L	304L	C22	Ti	Zr
	Low	High	Low	High					
Trichloroacetyl chloride					—	—	O	—	—
Trichlorobenzene					X	X	O	—	—
Trichlorobromomethane					—	—	O	—	—
Trichloroethane					O	—	O	O	O
Trichloroethylene (dry)					O	—	O	X	—
Trichloromethylpyridine					—	—	O	—	—
Trichloromonofluoroethane					O	—	O	—	—
Trichlorosilane (anhydrous)					O	X	O	X	—
Trichlorotrifluoroethane					O	—	O	—	—
Triethanolamine	0	95	0	100	O	—	O	O	—
Triethyl aluminum					O	—	O	X	—
Triethylamine					O	—	O	—	—
Triethylene glycol					O	—	O	O	—
Trifluoroacetic acid					X	X	O	X	—
Trimethyl sulfonium bromide					X	X	—	—	—
Trimethylchlorocyanate					—	X	O	—	—
Triphenylmethylchloride					X	X	O	—	—
Triphenyl phosphite					O	—	O	—	—
Trisodiumphosphate	0	200	0	90	—	—	O	—	—
	0	60	0	50	O	O	O	O	O
Tritylchloride					X	X	O	—	—
Turpentine					O	—	O	X	—

## 7.21 U chemical tables

### 7.21.1 U chemicals with Coriolis meters

Chemical	Temp °C		Conc. % wt		SS	C22	Ta	Ti
	Low	High	Low	High				
Urea	0	90	0	100	O	O	O	O

### 7.21.2 U chemicals with fork density and viscosity meters

Chemical	Temp °C		Conc. % wt		316L	304L	C22	Ti	Zr
	Low	High	Low	High					
Urea	0	90	0	100	O	—	O	O	O

## 7.22 V chemical tables

Table 7-20: Synonyms for V chemicals

Synonym	Listed under
Vinegar acid	Acetic acid
Vinyl benzene	Styrene
Vinyl cyanide	Acrylonitrile
Vinylformic acid	Acrylic acid
Vinyltrichlorosilane	Methyldichlorosilane
Vitriol brown oil	Sulfuric acid

### 7.22.1 V chemicals with Coriolis meters

Chemical	Temp °C		Conc. % wt		SS	C22	Ta	Ti
	Low	High	Low	High				
Vanadium benzene					O	O	—	—
Vanadium chloride					X	O	O	—
Vanadium oxychloride					X	O	O	—
Vanadium oxytrichloride					X	O		—
Vanadium tetrachloride					X	O	O	—
Vanadium triacetylacetonate					X	O	O	—
Varnish					O	O	O	—
Vazo					X	O	—	—
Vegetable tanning liquor	0	79	0	100	—	O	O	—
Vinegar					O	O	O	O
Vinyl acetate					O	O	—	O
Vinyl acetate polymer residues					O	O	—	—
Vinyl chloride (latex)	0	60	0	100	—	O	O	O
Vinyl chloride (monomer)	0	65	0	100	O	O	O	O
Vinyl fluoride					X	—	X	—
Vinylidene chloride					X	O	O	X

### 7.22.2 V chemicals with fork density and viscosity meters

Chemical	Temp °C		Conc. % wt		316L	304L	C22	Ti	Zr
	Low	High	Low	High					
Vanadium benzene					O	—	O	—	—
Vanadium chloride					X	X	O	—	—

Chemical	Temp °C		Conc. % wt		316L	304L	C22	Ti	Zr
	Low	High	Low	High					
Vanadium oxychloride					X	X	O	—	—
Vanadium oxytrichloride					X	X	O	—	—
Vanadium tetrachloride					X	X	O	—	—
Vanadium triacetylacetonate					—	—	O	—	—
Varnish					O	—	O	—	—
Vazo					—	X	O	—	—
Vegetable tanning liquor	0	79	0	100	—	—	O	—	—
Vinegar					O	—	O	O	—
Vinyl acetate					O	—	O	—	—
Vinyl acetate polymer residues					O	—	O	—	—
Vinyl chloride (latex)	0	60	0	100	—	—	O	—	—
Vinyl chloride (monomer)	0	65	0	100	O	—	O	—	—
Vinyl fluoride					—	—	O	—	—
Vinylidene chloride					X	X	O	—	O
Vitamin E					O	—	O	—	—

## 7.23 W chemical tables

Table 7-21: Synonyms for W chemicals

Synonym	Listed under
Waste liquor	Black liquor
Waste oil	Oil, waste
Water glass	Sodium silicate

### 7.23.1 W chemicals with Coriolis meters

Chemical	Temp °C		Conc. % wt		SS	C22	Ta	Ti
	Low	High	Low	High				
Water <sup>(1)</sup>	0	200	0	100	O	O	O	O
Water, flour, starch, and corn syrups					—	O	O	O
Wax emulsion					O	O	—	O
Whey and milk					O	O	O	O
Whiskey					O	O	O	O
White liquor	20	50	0	100	X	O	X	—

(1) Observe chloride limits shown in [Halogen](#)s.

## 7.23.2 W chemicals with fork density and viscosity meters

Chemical	Temp °C		Conc. % wt		316L	304L	C22	Ti	Zr
	Low	High	Low	High					
Water	0	200	0	100	O <sup>(1)</sup>	O <sup>(1)</sup>	O	O	O
Water/Flour/Starch/Corn syrup					—	—	O	O	—
Wax emulsion					O	—	O	O	—
Whey/Milk					O	—	O	O	—
Whisky					O	O	O	—	—
White liquor	20	50	0	100	—	—	O	—	—
Wine					O	—	O	O	—

(1) Observe the chloride limits shown in [Halogens](#).

## 7.24 X chemical tables

### 7.24.1 X chemicals with Coriolis meters

Chemical	Temp °C		Conc. % wt		SS	C22	Ta	Ti
	Low	High	Low	High				
Xylene	20	120	0	100	O	O	O	O

### 7.24.2 X chemicals with fork density and viscosity meters

Chemical	Temp °C		Conc. % wt		316L	304L	C22	Ti	Zr
	Low	High	Low	High					
Xylene	20	120	0	100	O	—	O	O	O

## 7.25 Y chemical tables

### 7.25.1 Y chemicals with Coriolis meters

Chemical	SS	C22	Ta	Ti
Yeast	O	O	—	—
Yogurt	O	O	O	—

### 7.25.2 Y chemicals with fork density and viscosity meters

Chemical	316L	304L	C22	Ti	Zr
Yeast	O	—	O	—	O
Yogurt	O	—	O	—	—

## 7.26 Z chemical tables

### 7.26.1 Z chemicals with Coriolis meters

Chemical	Temp °C		Conc. % wt		SS	C22	Ta	Ti
	Low	High	Low	High				
Zeolite Maximum slurry velocity is 6 ft/sec (1.8 m/sec)					—	O	—	—
Zinc carbonate slurry	0	21	0	100	—	O	O	—
	21	82	0	100	—	O	O	—
Zinc chloride	0	107	0	71	X	O	O	O
Zinc dialkyl dithiophosphate					X	O	O	—
Zinc hydrosulfite	0	120	0	10	X	O	O	—
Zinc sulfate	0	111	0	34	X	O	O	O
Zirconium chloride	0	85	0	25	X	O	O	—

### 7.26.2 Z chemicals with fork density and viscosity meters

Chemical	Temp °C		Conc. % wt		316L	304L	C22	Ti	Zr
	Low	High	Low	High					
Zeolite					—	—	O	—	—
Zinc carbonate slurry	0	21	0	100	—	—	O	—	—
	21	82	0	100	—	—	O	—	—
Zinc chloride	0	107	0	71	X	X	O	O	—
Zinc dialkyl dithiophosphate					—	—	O	—	—
Zinc hydrosulfite	0	120	0	10	—	—	O	—	—
Zinc sulfate	0	111	0	34	—	—	O	O	—
Zirconium chloride	0	85	0	25	X	X	O	—	—



GI-00415  
Rev. K  
2025

For more information: [Emerson.com/global](https://emerson.com/global)

©2025 Micro Motion, Inc. All rights reserved.

The Emerson logo is a trademark and service mark of Emerson Electric Co. Micro Motion, ELITE, ProLink, MVD and MVD Direct Connect marks are marks of one of the Emerson Automation Solutions family of companies. All other marks are property of their respective owners.

**MICRO MOTION™**

