

Rosemount™ 8700 Magnetic Flowmeter Sensor



Contents

Handling and lifting safety.....3

Introduction.....5

Location and position.....7

Sensor installation.....10

Process reference connection.....23

Wiring sensor to transmitter.....27

Product certifications.....35

1 Handling and lifting safety

⚠ CAUTION

To reduce the risk of personal injury or damage to equipment, follow all lifting and handling instructions.

- Handle all parts carefully to prevent damage. Whenever possible, transport the system to the installation site in the original shipping container.
 - PTFE-lined sensors are shipped with end covers that protect flange sealing surfaces from both mechanical damage and normal unrestrained distortion. Remove the end covers just before installation.
 - Keep the shipping plugs in the conduit ports until you are ready to connect and seal them. Appropriate care should be taken to prevent water ingress by replacing the shipping plugs with a permanent plug/conduit seal.
 - The sensor should be supported by the pipeline. Pipe supports are recommended on both the inlet and outlet sides of the sensor pipeline. There should be no additional support attached to the sensor.
 - Use proper Personal Protection Equipment (PPE) including safety glasses and safety shoes.
 - Do not lift the meter by holding the electronics housing or junction box.
 - The sensor liner is vulnerable to handling damage. Never place anything through the sensor for the purpose of lifting or gaining leverage. Liner damage can render the sensor useless.
 - Do not drop the device from any height.
-

1.1 Lifting lugs

⚠ CAUTION

If provided, use the lifting lugs on each flange to handle the flow meter when it is transported and lowered into place at the installation site. If lifting lugs are not provided, the flow meter must be supported with a lifting sling on each side of the housing.

- Standard pressure 3-inch through 36-inch flanged magnetic flow meters come with lifting lugs.
- High pressure (above Class 600) 1-inch through 24-inch flanged magnetic flow meters come with lifting lugs.
- Wafers and sanitary magnetic flow meters do not come with lifting lugs.

Figure 1-1: Example Lifting Without and With Lifting Lugs

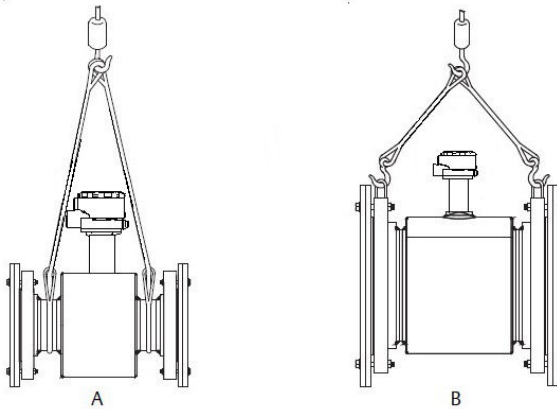

A. *Without lifting lugs*

B. *With lifting lugs*

2 Introduction

This document provides basic installation guidelines for the Rosemount 8700 Magnetic Flow Meter sensor.

- For transmitter installation instructions, refer to the appropriate document:

Product name	Document number ⁽¹⁾
8732EM Transmitter with HART® Protocol	00825-01xx-4444
8732EM Transmitter with FOUNDATION™ fieldbus	00825-05xx-4444
8732EM Transmitter with Modbus® RS-485 Protocol	00825-04xx-4444
8732EM Transmitter with EtherNet/IP	00825-06xx-4444
8712EM Transmitter with FOUNDATION™ fieldbus	00825-05xx-4445
8712EM Transmitter with Modbus® RS-485 Protocol	00825-04xx-4445
8732E Magnetic Flowmeter System	00825-01xx-4662
8732E Magnetic Flowmeter System with FOUNDATION™ fieldbus	00825-01xx-4663
8732E Magnetic Flowmeter System with PROFIBUS PA digital fieldbus	00825-01xx-4665
8712E Magnetic Flowmeter System	00825-01xx-4664

(1) "xx" in the second segment of the document number indicates the language. See [Table 2-1](#).

- For additional installation information, configuration, maintenance, and troubleshooting, refer to the appropriate product reference manual.

Table 2-1: Document language codes

Code	Language
00	English
02	Italian
03	French
04	Japanese
05	German
06	Chinese (Simplified)
07	Russian

Table 2-1: Document language codes (continued)

Code	Language
09	Spanish
15	Korean
22	Portuguese (Brazilian)

All user documentation can be found at www.emerson.com. For more contact information, see [Emerson Flow customer service](#).

2.1 Return policy

Emerson procedures must be followed when returning equipment. These procedures ensure legal compliance with government transportation agencies and help provide a safe working environment for Emerson employees. Failure to follow Emerson procedures will result in your equipment being refused delivery.

2.2 Emerson Flow customer service

Email:

- Worldwide: flow.support@emerson.com
- Asia-Pacific: APflow.support@emerson.com
- Middle East/Africa: Flow TechnicalSupport@emerson.com

3 Location and position

3.1 Environmental considerations

To ensure maximum transmitter life, avoid extreme temperatures and excessive vibration. Typical problem areas include the following:

- High-vibration lines with integrally mounted transmitters
- Tropical/desert installations in direct sunlight
- Outdoor installations in arctic climates

3.2 Upstream and downstream piping

To ensure specified accuracy over widely varying process conditions, Emerson recommends installing the sensor with a minimum of five straight pipe diameters upstream and two pipe diameters downstream from the electrode plane.

Figure 3-1: Upstream and Downstream Straight Pipe Diameters

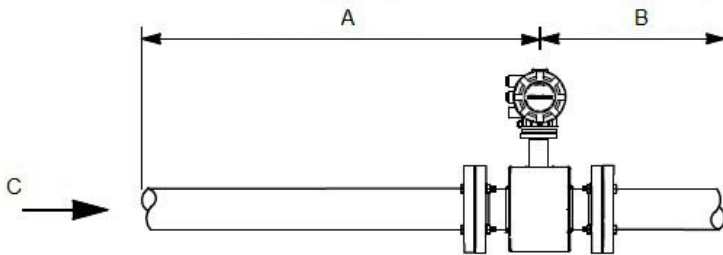

- A. Five pipe diameters (upstream)
- B. Two pipe diameters (downstream)
- C. Flow direction

Installations with reduced upstream and downstream straight runs are possible. In reduced straight run installations, the meter may not meet accuracy specifications. Reported flow rates will still be highly repeatable.

3.3 Flow direction

The sensor should be mounted so that the arrow points in the direction of flow.

Figure 3-2: Flow Direction Arrow



3.4 Sensor piping location and orientation

The sensor should be installed in a location that ensures it remains full during operation. Depending on where it is installed, orientation must also be considered.

- Vertical installation with upward process fluid flow keeps the cross-sectional area full, regardless of flow rate.
- Horizontal installation should be restricted to low piping sections that are normally full.

Figure 3-3: Sensor Orientation

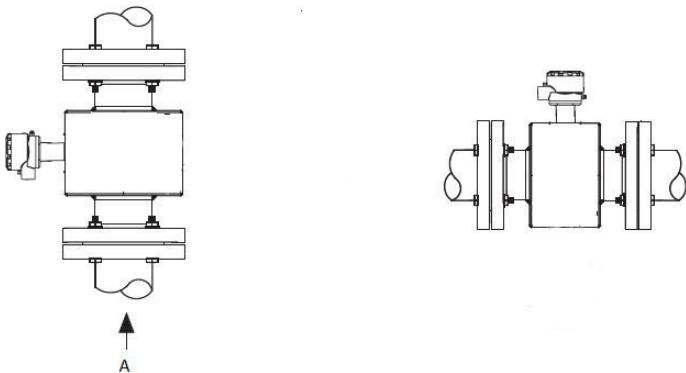

A. Flow direction

3.5 Transmitter or remote junction box rotation

To rotate housing, disconnect the interconnecting cables from the electronics board inside the transmitter housing prior to rotation.

3.6 Electrode orientation

The electrodes in the sensor are properly oriented when the two measurement electrodes are in the 3 and 9 o'clock positions or within 45 degrees from the horizontal, as shown on the left side of [Figure 3-4](#). Avoid any mounting orientation that positions the top of the sensor at 90 degrees from the vertical position as shown on the right of [Figure 3-4](#).

Figure 3-4: Electrode Orientation

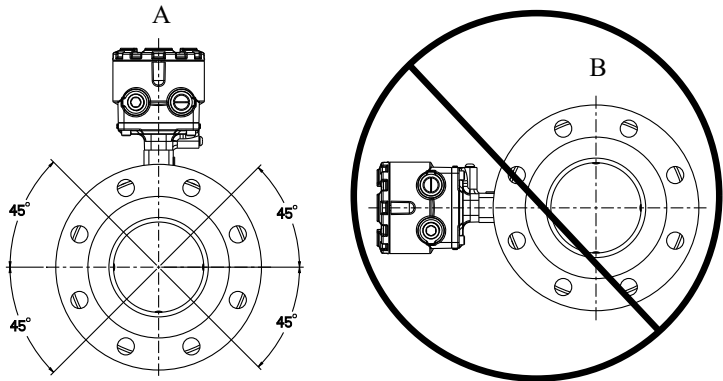

- A. *Correct orientation*
- B. *Incorrect orientation*

The sensor may require a specific orientation to comply with Hazardous Area T-code rating. Refer to the appropriate reference manual for any potential restrictions.

4 Sensor installation

4.1 Flanged sensors

Gaskets

- It is the responsibility of the customer to provide an appropriate gasket for their installation.
- The gasket material must be compatible with the process fluid and process conditions. See note below for more information regarding suitable gasket materials.
- If no ground rings or lining protectors are being used, a gasket is required at each process connection. See [Figure 4-1](#).
- If using grounding ring(s), a gasket is required on each side of each grounding ring. See [Figure 4-2](#).
- If using lining protectors, a gasket is required between each lining protector and each process connection. See [Figure 4-3](#) and [Figure 4-4](#).

NOTICE

- Metallic or spiral wound gaskets should not be used in contact with the liner face. **They will damage the liner face.** If metallic or spiral wound gaskets are required for the application, then lining protectors must be used.
- Examples of non-metallic gasket materials that will not damage the liner face are rubber, fiber, or PTFE.
- Flat ring gasket types are suitable for raised-face (RF) flanges. Full-face gasket types are suitable for flat-face (FF) flanges. Full-face gaskets may be used with raised-face flanges.

Figure 4-1: Flanged Gasket Placement with no Grounding Ring(s) or Lining Protector(s)

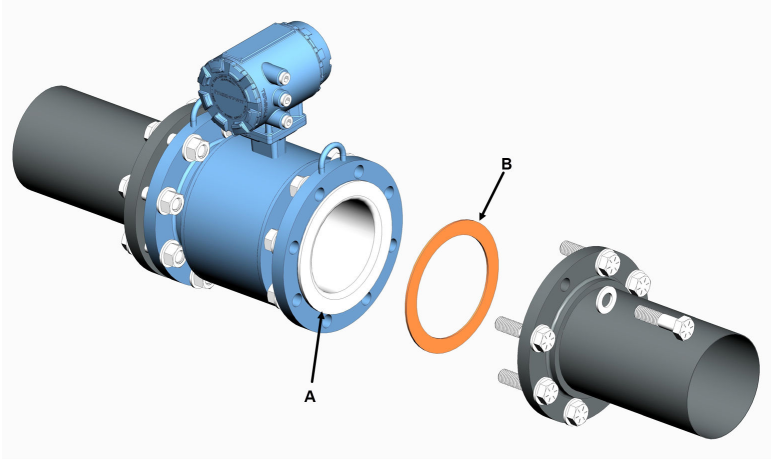

- A. Liner face
- B. Customer supplied gasket (x2)

Figure 4-2: Flanged Gasket Placement with Grounding Ring(s)

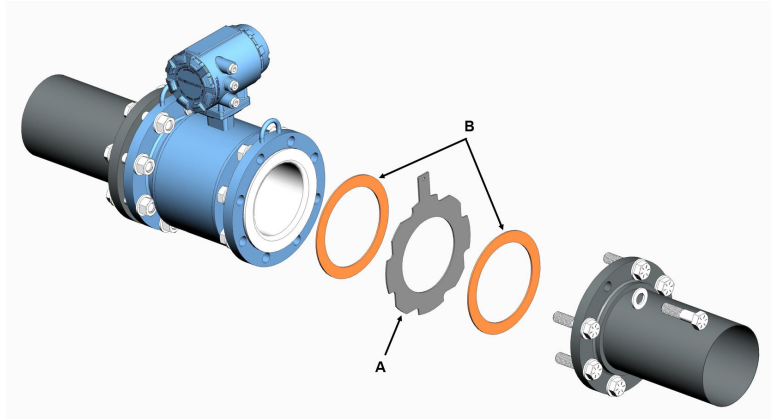

- A. Ground ring
- B. Customer supplied gaskets (x2 per ground ring)

Figure 4-3: Flanged Gasket Placement with Stamped Lining Protector(s)

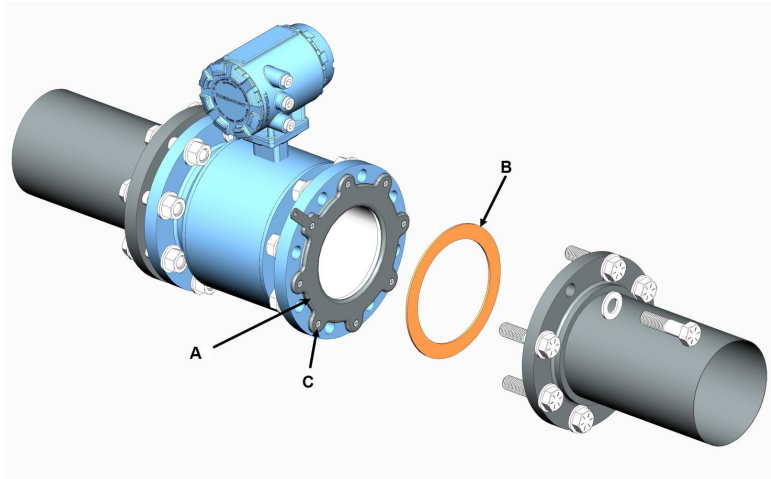

- A. Stamped lining protector
 - B. Customer supplied gasket (x1 per lining protector)
 - C. Lining protector fastening screws — **DO NOT REMOVE** the screws or the lining protector.
-

Figure 4-4: Flanged Gasket Placement with Machined Stamped Lining Protector(s)

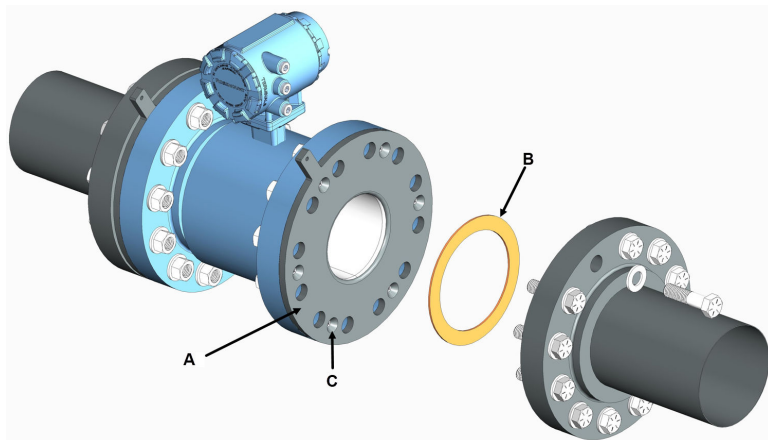

- A. Machined lining protector
- B. Customer supplied gasket (x1 per lining protector)
- C. Lining protector fastening screws — **DO NOT REMOVE** the screws or the lining protector.

Bolts

NOTICE

Do not bolt one side at a time. Tighten both sides simultaneously.
Example:

1. Snug upstream
2. Snug downstream
3. Tighten upstream (20%)
4. Tighten downstream (20%)

Do not snug and tighten the upstream side and then snug and tighten the downstream side. Failure to alternate between the upstream and downstream flanges when tightening bolts may result in liner damage.

Suggested torque values by sensor line size and liner type are listed in [Table 4-2](#) for ASME B16.5 flanges and [Table 4-3](#) or [Table 4-4](#) for EN flanges. Consult the factory if the flange rating of the sensor is not listed. Tighten flange bolts on the upstream side of the sensor in the

incremental sequence shown in [Figure 4-5](#) to 20% of the suggested torque values. Repeat the process on the downstream side of the sensor. For sensors with greater or fewer flange bolts, tighten the bolts in a similar crosswise sequence. Repeat this entire tightening sequence at 40%, 60%, 80%, and 100% of the suggested torque values.

If leakage occurs at the suggested torque values, the bolts can be tightened in additional 10% increments until the joint stops leaking, or until the measured torque value reaches the maximum torque value of the bolts. Practical consideration for the integrity of the liner often leads to distinct torque values to stop leakage due to the unique combinations of flanges, bolts, gaskets, and sensor liner material.

Check for leaks at the flanges after tightening the bolts. Failure to use the correct tightening methods can result in severe damage. While under pressure, sensor materials may deform over time and require a second tightening 24 hours after the initial installation.

Figure 4-5: Flange bolt torquing sequence

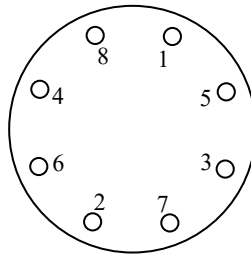

Prior to installation, identify the lining material of the flow sensor to ensure the suggested torque values are applied.

Table 4-1: Lining material

Group A	Group B
T - PTFE	P - Polyurethane
F - ETFE	N - Neoprene
A - PFA	L - Linatex (Natural Rubber)
K - PFA+	D - Adiprene
	H - PEX

Table 4-2: Suggested flange bolt torque values for Group A and Group B (ASME)

Size code	Line size	Group A		Group B	
		Class 150 (pound-feet)	Class 300 (pound-feet)	Class 150 (pound-feet)	Class 300 (pound-feet)
005	0.5 inch (15 mm)	4	8	N/A	N /A
010	1 inch (25 mm)	8	19	6	20
015	1.5 inch (40 mm)	17	36	13	38
020	2 inch (50 mm)	34	20	26	21
025	2.5 inch (65 mm)	40	30	30	31
030	3 inch (80 mm)	58	37	44	39
040	4 inch (100 mm)	41	50	31	52
050	5 inch (125 mm)	61	61	46	62
060	6 inch (150 mm)	77	51	59	50
080	8 inch (200 mm)	105	81	79	77
100	10 inch (250 mm)	98	84	74	81
120	12 inch (300 mm)	131	126	99	110
140	14 inch (350 mm)	162	110	123	98
160	16 inch (400 mm)	154	154	117	123
180	18 inch (450 mm)	236	175	179	133
200	20 inch (500 mm)	207	191	157	145
240	24 inch (600 mm)	293	293	222	222
300	30 inch (750 mm)	309	432	234	328
360	36 inch (900 mm)	442	589	335	447

Table 4-3: Suggested flange bolt torque values for Group A (EN 1092-1)

Size code	Line size	Group A (in Newton-meters)			
		PN 10	PN 16	PN 25	PN 40
005	0.5 inch (15 mm)	N/A	N/A	N/A	10
010	1 inch (25 mm)	N/A	N/A	N/A	23
015	1.5 inch (40 mm)	N/A	N/A	N/A	49
020	2 inch (50 mm)	N/A	62	N/A	62
025	2.5 inch (65 mm)	N/A	43	N/A	43
030	3 inch (80 mm)	N/A	51	N/A	51
040	4 inch (100 mm)	N/A	53	76	76
050	5.0 inch (125 mm)	N/A	70	N/A	106
060	6 inch (150mm)	N/A	95	132	132
080	8 inch (200 mm)	135	90	134	180
100	10 inch (250 mm)	103	123	200	265
120	12 inch (300 mm)	118	170	205	285
140	14 inch (350 mm)	166	223	344	450
160	16 inch (400 mm)	227	298	445	662
180	18 inch (450 mm)	198	299	391	452
200	20 inch (500 mm)	225	408	474	558
240	24 inch (600 mm)	300	601	625	903

Table 4-4: Suggested flange bolt torque values for Group B (EN 1092-1)

Size code	Line size	Group B (in Newton-meters)			
		PN 10	PN 16	PN 25	PN 40
005	0.5 inch (15 mm)	N/A	N/A	N/A	8
010	1 inch (25 mm)	N/A	N/A	N/A	18
015	1.5 inch (40 mm)	N/A	N/A	N/A	37
020	2 inch (50 mm)	N/A	47	N/A	47
025	2.5 inch (65 mm)	N/A	33	N/A	33
030	3 inch (80 mm)	N/A	38	N/A	38
040	4 inch (100 mm)	N/A	41	57	57
050	5.0 inch (125 mm)	N/A	53	N/A	81

Table 4-4: Suggested flange bolt torque values for Group B (EN 1092-1)
(continued)

Size code	Line size	Group B (in Newton-meters)			
		PN 10	PN 16	PN 25	PN 40
060	6 inch (150mm)	N/A	72	100	100
080	8 inch (200 mm)	103	68	102	137
100	10 inch (250 mm)	78	94	152	201
120	12 inch (300 mm)	89	129	156	216
140	14 inch (350 mm)	126	169	261	341
160	16 inch (400 mm)	172	226	337	502
180	18 inch (450 mm)	150	227	296	343
200	20 inch (500 mm)	170	309	359	423
240	24 inch (600 mm)	228	456	474	685

4.2 Wafer sensors

When installing wafer sensors, there are several components that must be included and requirements that must be met.

Figure 4-6: Wafer sensors installation components and assembly requirements

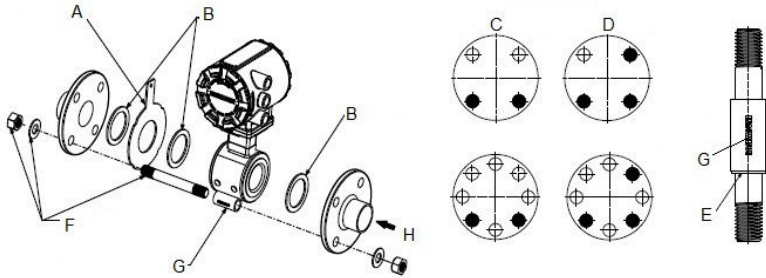

- A. Ground ring (optional)
- B. Customer supplied gaskets
- C. Spacer installation (horizontal meters)
- D. Spacer installation (vertical meters)
- E. O-ring
- F. Installation studs, nuts, and washers (optional)
- G. Wafer alignment spacer
- H. Flow

Gaskets

The sensor requires a gasket at each process connection. The gasket material selected must be compatible with the process fluid and operating conditions. Gaskets are required on each side of a grounding ring. See [Figure 4-6](#).

NOTICE

Metallic or spiral-wound gaskets should not be used as they will damage the liner face of the sensor.

Alignment spacers

On 1.5 inch through 8 inch (40 through 200 mm) line sizes, alignment spacers are **required** to ensure proper centering of the wafer sensor between the process flanges. To order an Alignment Spacer Kit (quantity 3 spacers), use p/n 08711-3211-xxxx, where xxxx equals the dash number shown in [Table 4-5](#).

Table 4-5: Alignment spacers

Dash-no. (-xxxx)	Line size		Flange rating
	(in)	(mm)	
0A15	1.5	40	JIS 10K-20K
0A20	2	50	JIS 10K-20K
0A30	3	80	JIS 10K
0B15	1.5	40	JIS 40K
AA15	1.5	40	ASME- 150#
AA20	2	50	ASME - 150#
AA30	3	80	ASME - 150#
AA40	4	100	ASME - 150#
AA60	6	150	ASME - 150#
AA80	8	200	ASME - 150#
AB15	1.5	40	ASME - 300#
AB20	2	50	ASME - 300#
AB30	3	80	ASME - 300#
AB40	4	100	ASME - 300#
AB60	6	150	ASME - 300#
AB80	8	200	ASME - 300#
DB40	4	100	EN 1092-1 - PN10/16
DB60	6	150	EN 1092-1 - PN10/16
DB80	8	200	EN 1092-1 - PN10/16
DC80	8	200	EN 1092-1 - PN25
DD15	1.5	40	EN 1092-1 - PN10/16/25/40
DD20	2	50	EN 1092-1 - PN10/16/25/40
DD30	3	80	EN 1092-1 - PN10/16/25/40
DD40	4	100	EN 1092-1 - PN25/40
DD60	6	150	EN 1092-1 - PN25/40
DD80	8	200	EN 1092-1 - PN40
RA80	8	200	AS40871-PN16
RC20	2	50	AS40871-PN21/35
RC30	3	80	AS40871-PN21/35

Table 4-5: Alignment spacers (continued)

Dash-no. (-xxxx)	Line size		Flange rating
	(in)	(mm)	
RC40	4	100	AS40871-PN21/35
RC60	6	150	AS40871-PN21/35
RC80	8	200	AS40871-PN21/35

Studs

Wafer sensors require threaded studs. See [Figure 4-7](#) for torque sequence. Always check for leaks at the flanges after tightening the flange bolts. All sensors require a second tightening 24 hours after initial flange bolt tightening.

Table 4-6: Stud specifications

Nominal sensor size	Stud specifications
0.15-1-in. (4-25 mm)	316 SST ASTM A193, Grade B8M, Class 1 threaded mounted studs
1½-8-in. (40-200 mm)	CS, ASTM A193, Grade B7, threaded mounting studs

Figure 4-7: Flange bolt torquing sequence

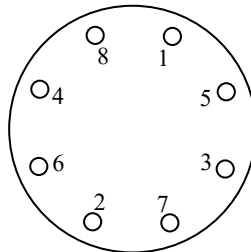

4.2.1 Installation

Procedure

1. Insert studs for the bottom side of the sensor between the pipe flanges and center the alignment spacer in the middle of the stud. See [Figure 4-6](#) for the bolt hole locations recommended for the spacers provided. Stud specifications are listed in [Table 4-6](#).
2. Place the sensor between the flanges. Make sure the alignment spacers are properly centered on the studs. For

vertical flow installations slide the o-ring over the stud to keep the spacer in place. See [Figure 4-6](#). Ensure the spacers match the flange size and class rating for the process flanges. See [Table 4-5](#).

3. Insert the remaining studs, washers, and nuts.
4. Tighten to the torque specifications shown in [Table 4-7](#). Do not over-tighten the bolts or the liner may be damaged.

Table 4-7: Rosemount 8711 torque specifications

Size code	Line size	Pound-feet	Newton-meter
15F	0.15 inch (4 mm)	5	7
30F	0.30 inch (8 mm)	5	7
005	½ inch (15 mm)	5	7
010	1 inch (25 mm)	10	14
015	1.5 inch (40 mm)	15	20
020	2 inch (50 mm)	25	34
030	3 inch (80 mm)	40	54
040	4 inch (100 mm)	30	41
060	6 inch (150 mm)	50	68
080	8 inch (200 mm)	70	95

4.3 Sanitary sensors

IDF Fitting

The 8721 uses an IDF (international dairy federation) style fitting to connect the process connection fitting to the meter body.

IDF Sanitary fitting torque

Hand tighten IDF nut to approximately 50 in-lbs [5 ½ Newton-meters (N-m)] of torque. Re-tighten after a few minutes until there are no leaks (up to 130 in-lbs [14 ½ Newton-meters (N-m)] of torque). Fittings that continue to leak at a higher torque may be distorted or damaged.

NOTICE

Gaskets are supplied between the IDF fitting and the process connection fitting, such as a Tri-Clamp fitting, on all Rosemount 8721 Sanitary sensors except when the process connection fittings are not supplied and the only connection type is an IDF fitting.

Gaskets

The sensor requires a gasket at each of its connections to adjacent devices or piping. The gasket material selected must be compatible with the process fluid and operating conditions.

Alignment and clamping of user-supplied clamp

Standard plant practices should be followed when installing a magmeter with sanitary fittings. Unique torque values and bolting techniques are not required.

Figure 4-8: Sanitary sensor gasket and clamp alignment

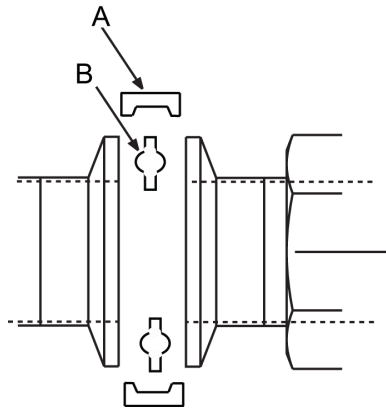

- A. User-supplied clamp
- B. User-supplied gasket

5 Process reference connection

The figures shown in this section illustrate best practice installations for process reference connections only. For installations in conductive, unlined pipe, it may be acceptable to use one ground ring or one lining protector to establish a process reference connection. Earth safety ground is also required as part of this installation, but is not shown in the figures. Follow national, local, and plant electrical codes for safety ground.

Use [Table 5-1](#) to determine which process reference option to follow for proper installation.

Table 5-1: Process Reference Options

Type of pipe	Grounding straps	Grounding rings	Reference electrode	Lining protectors
Conductive unlined pipe	See Figure 5-1	See Figure 5-2	See Figure 5-4	See Figure 5-2
Conductive lined pipe	Insufficient grounding	See Figure 5-2	See Figure 5-1	See Figure 5-2
Non-conductive pipe	Insufficient grounding	See Figure 5-3	Not recommended	See Figure 5-3

NOTICE

For line sizes 10 inches and larger, the ground strap may come attached to the sensor body near the flange. See [Figure 5-5](#).

Figure 5-1: Grounding Straps in Conductive Unlined Pipe or Reference Electrode in Lined Pipe

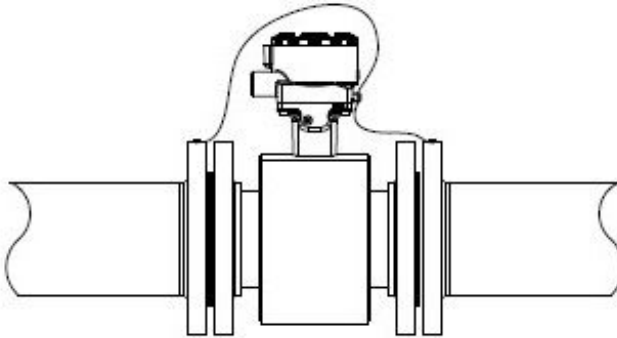
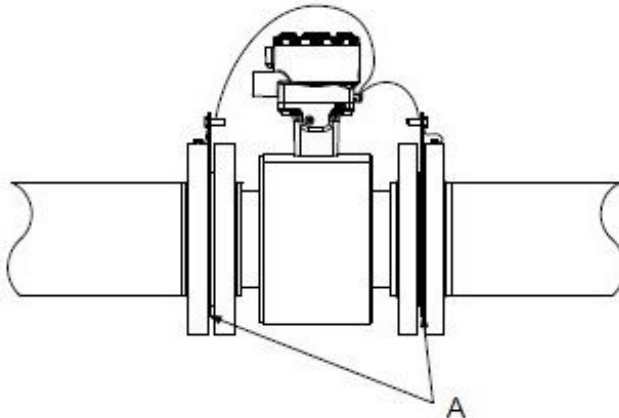
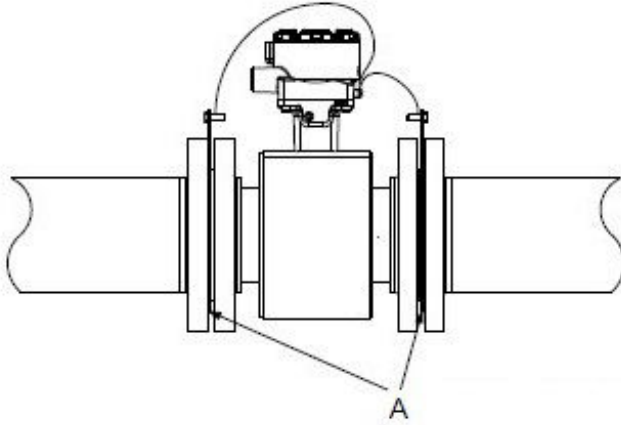

Figure 5-2: Grounding with Grounding Rings or Lining Protectors in Conductive Pipe



A. Grounding rings or lining protectors

Figure 5-3: Grounding with Grounding Rings or Lining Protectors in Non-Conductive Pipe



A. Grounding rings or lining protectors

Figure 5-4: Grounding with Reference Electrode in Conductive Unlined Pipe

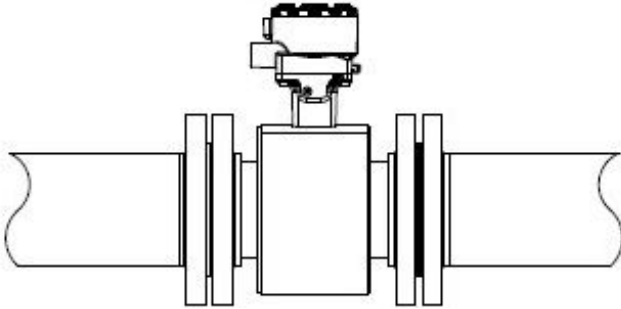
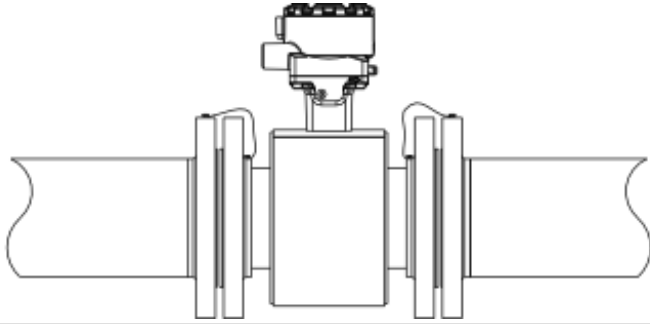

Figure 5-5: Grounding for Line Sizes 10 inches and Larger



7 Product certifications

For detailed approval certification information and installation drawings, see the appropriate document listed below:

- [Document number 00825-MA00-0001: *Rosemount 8700M Approval Document - IECEx and ATEX*](#)
- [Document number 00825-MA00-0002: *Rosemount 8700M Approval Document – Class Division*](#)
- [Document number 00825-MA00-0003: *Rosemount 8700M Approval Document - North America Zone*](#)
- [Document number 00825-MA00-0007: *Rosemount 8700M Approval Document - NEPSI EN Zone 1 China*](#)



Quick Install Guide
00825-0100-4727, Rev. DG
October 2025

For more information: [Emerson.com/global](https://www.emerson.com/global)

©2025 Emerson. All rights reserved.

Emerson Terms and Conditions of Sale are available upon request. The Emerson logo is a trademark and service mark of Emerson Electric Co. Rosemount is a mark of one of the Emerson family of companies. All other marks are the property of their respective owners.

ROSEMOUNT™

