

Rosemount™ 9930 Magnetic Level Indicator



- Designed for both gas/liquid (top level) and/or liquid/liquid (interface) measurements
- Dual chamber design optimized for use with the Rosemount 5300, 3308, and 3300 Guided Wave Radars also available
- Visual level indication to 100 ft. (30 m)
- Optional construction is available for cryogenic, high-temperature, high-pressure, and corrosive applications

Overview

Measurement principle

Rosemount 9930 Magnetic Level Indicator consists of a chamber, a magnet equipped float which rises and lowers with the fluid level, and an indicator mounted to the chamber.

Figure 1: Overview

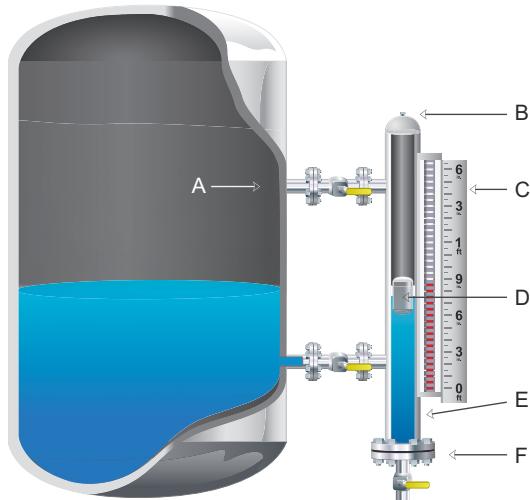

- A. Process connections
- B. Vent
- C. Indicator
- D. Float
- E. Float chamber
- F. Drain

The indicator houses a column of small flags, which indicate the level of the fluid in the chamber, based on the position of the float. As the fluid level rises and lowers, the float rises and lowers as well, and the flags are tripped from one orientation to the other; typically the red side indicates the liquid level and the silver side indicates the vapor space.

As the float rises and falls with the process level, the individual flags within the indicator will be triggered to flip due to the magnetic field within the float. It will also trigger any externally mounted control devices such as magnetostrictive transmitters and magnetic switches, providing a signal back to the control system.

Contents

Overview.....	2
Ordering information.....	4
Specifications.....	15
Dimensional drawings.....	18

Features and benefits

- Minimal leak points as compared to sight glasses.
- No process liquid in contact with indicator glass.
- Designed to ASME B31.3 Process Piping Code. ASME B31.1 Power Piping Code is available upon request.
- Built to NACE standards upon request.

Application examples

- Turbulent tanks
- Heat exchangers
- Boiler applications
- Site glass replacement
- Separators
- Acid storage tanks

Test and inspection

All Rosemount chambers can be hydrostatically tested to 1.5 times the Maximum Allowable Working Pressure (MAWP) of the specified flange/pressure rating prior to shipment to ensure pressure tolerance.

Consult the factory for additional testing and documentation are available for all other testings.

- Material Traceability Reports (MTRs)
- Dye penetrant
- Radiography
- Hydrostatic pressure test certificates
- Positive Material Identification (PMI)
- Witness testing

Ordering information

Rosemount 9930 Magnetic Level Indicator (MLI) ordering information



Specification and selection of product materials, options, or components must be made by the purchaser of the equipment, see [Rosemount 9930 Magnetic Level Indicator Configuration Data Sheet](#). See [Material selection](#) for more information.

[VIEW PRODUCT >](#)

Model

Code	Description
9930	Rosemount 9930 Magnetic Level Indicator

Measurement type

For flashing applications, consult factory.

Code	Description
0	Liquid level (gas/liquid interface)
2	Submerged interface (liquid/liquid interface)
4	Flashing application (Consult factory for model selection) (Applicable only to top level measurement)

Float selection

Table 1: Liquid Level (Gas/Liquid Interface) Applications, Measurement Type Code 0

Code	Description				
	Float material	Minimum SG	Float max. operating pressure in psig (bar) at 100 °F (37.8 °C)	Chamber size and schedule (nominal pipe size)	"A" Dimension in inches (mm)
76	316 Stainless steel	0.76	167 (11.5)	2" S10	12.0 in. (305 mm)
78	316 Stainless steel	0.78	440 (30.3)	2" S10	12.0 in. (305 mm)
81	316 Stainless steel	0.81	662 (45.6)	2" S10	12.0 in. (305 mm)
58	316 Stainless steel	0.58	94 (6.4)	2½" S10	12.0 in. (305 mm)
60	316 Stainless steel	0.60	176 (12.1)	2½" S10	12.0 in. (305 mm)

Table 1: Liquid Level (Gas/Liquid Interface) Applications, Measurement Type Code 0 (continued)

Code	Description				
	Float material	Minimum SG	Float max. operating pressure in psig (bar) at 100 °F (37.8 °C)	Chamber size and schedule (nominal pipe size)	"A" Dimension in inches (mm)
62	316 Stainless steel	0.62	284 (19.5)	2½" S10	12.0 in. (305 mm)
83	316 Stainless steel	0.83	486 (33.5)	2½" S10	12.0 in. (305 mm)
86	316 Stainless steel	0.86	948 (65.3)	2½" S10	12.0 in. (305 mm)
54	Titanium	0.54	178 (12.2)	2½" S10	12.0 in. (305 mm)
59	Titanium	0.59	471 (32.4)	2½" S10	12.0 in. (305 mm)
61	Titanium	0.61	740 (51.0)	2½" S10	12.0 in. (305 mm)
68	316 Stainless steel	0.68	154 (10.6)	2½" S40	12.0 in. (305 mm)
82	316 Stainless steel	0.82	232 (15.9)	2½" S40	12.0 in. (305 mm)
87	316 Stainless steel	0.87	518 (35.7)	2½" S40	12.0 in. (305 mm)
88	316 Stainless steel	0.88	930 (64.1)	2½" S40	12.0 in. (305 mm)
40	316 Stainless steel	0.40	53 (3.6)	3" S10	18 in. (457 mm)
69	Titanium	0.69	2300 (158.6)	2½" S40	16 in. (406 mm)
63	Titanium	0.63	2300 (158.6)	2½" S40	20 in. (508 mm)
45	Titanium	0.45	2100 (144.8)	3" S10	20 in. (508 mm)
55	Titanium	0.55	2100 (144.8)	3" S40	14 in. (356 mm)
49	Titanium	0.49	2100 (144.8)	3" S40	17 in. (432 mm)
46	Titanium	0.46	2100 (144.8)	3" S40	20 in. (508 mm)
41	Titanium	0.41	2100 (144.8)	3" S40	25 in. (635 mm)
74	Titanium	0.74	3400 (234.4)	3" S80	20 in. (508 mm)
67	Titanium	0.67	3400 (234.4)	3" S80	25 in. (635 mm)
85	Titanium	0.85	3400 (234.4)	3" S160	16 in. (406 mm)
73	Titanium	0.73	3400 (234.4)	3" S160	20 in. (508 mm)
64	Alloy 400	0.64	90 (6.2)	3" S10	12 in. (305 mm)
80	C-276	0.80	135 (9.3)	2" S10	12 in. (305 mm)
89	C-276	0.89	425 (29.3)	2" S10	12 in. (305 mm)

Table 2: Submerged Interface (Liquid/Liquid Interface) Applications, Measurement Type Code 2

Code	Description				
	Float material	Minimum delta SG	Float max. operating pressure in psig (bar) at 100 °F (37.8 °C)	Chamber size and schedule (nominal pipe size)	"A" Dimension in inches (mm)
37	316 Stainless steel	0.37	662 (45.6)	2" S10	12 in. (305 mm)
21	316 Stainless steel	0.21	948 (65.3)	2½" S10	12 in. (305 mm)
23	316 Stainless steel	0.23	232 (15.9)	2½" S40	12 in. (305 mm)
10	316 Stainless steel	0.10	53 (3.6)	3" S10	12 in. (305 mm)
28	Titanium	0.28	2300 (158.6)	2½" S40	12 in. (305 mm)
20	Titanium	0.20	2300 (158.6)	2½" S40	12 in. (305 mm)

Table 2: Submerged Interface (Liquid/Liquid Interface) Applications, Measurement Type Code 2 (continued)

Code	Description				
	Float material	Minimum delta SG	Float max. operating pressure in psig (bar) at 100 °F (37.8 °C)	Chamber size and schedule (nominal pipe size)	"A" Dimension in inches (mm)
15	Titanium	0.15	2100 (144.8)	3" S10	12 in. (305 mm)
14	Titanium	0.14	2100 (144.8)	3" S40	12 in. (305 mm)
11	Titanium	0.11	2100 (144.8)	3" S40	12 in. (305 mm)
30	Titanium	0.30	3400 (234.4)	3" S80	12 in. (305 mm)
29	Titanium	0.29	3400 (234.4)	3" S160	12 in. (305 mm)
38	C-276	0.38	135 (9.3)	2" S10	12 in. (305 mm)
13	Alloy 400	0.13	90 (6.2)	3" S10	12 in. (305 mm)

Mounting style

Figure 2 for mounting options or consult factory for custom mounting.

Code	Description
A	Style A - Flanged top and bottom, with stop plates, no side process connection
B	Style B - Access flange on top and bottom with side process connections
C	Style C - Access flange on bottom, flanged bottom with side(s) process connections
D	Style D - Access flange on top, flanged top, closed bottom with side(s) process connections
L	Style L - No float access flanges, with or without sides(s) process connection

Instrument rating

Code	Description
AA	ANSI/ASME B16.5 Class 150
AB	ANSI/ASME B16.5 Class 300
AC	ANSI/ASME B16.5 Class 600
AD	ANSI/ASME B16.5 Class 900
AE	ANSI/ASME B16.5 Class 1500
AF	ANSI/ASME B16.5 Class 2500

Access flange type

Code	Description
0	Not applicable (Style L only)
1	Raised Face (RF) Weld Neck
2	RF Slip-On
4	Ring Type Joint (RTJ) Weld Neck

Unit of measure

Code	Description
E	Imperial (English), inches
M	Metric, millimeters

Mounting dimension (center-to-center for style B, C, D, L, and top-to-bottom for style A)

Maximum mounting dimension per single unit is 20 ft. (6 m) for Style A and 18 ft. (5.5 m) for Style B/C/D.

Code	Description
XXXXX	XXX.XX inches or XXXXX mm
	04863 = 48.63 inches or 04863 mm

Chamber material

Code	Description
S	316/316L Stainless steel (standard)
1	317 Stainless steel
2	321 Stainless steel
7	347 Stainless steel
X	Special (consult factory)

Branch connection design

Code	Description
D	Drill (Set-On)
E	Extrusion (limited up to 3-inch NPS chamber size S10 or S40 with 1½-inch or 2-inch NPS process connection size)
T	Buttweld Tee (ASME B16.9)
N	None (Style A)
X	Special (consult factory)

Process connection size (NPS)

Code	Description
0	Same diameter as chamber (Style A only)
8	½-inch
9	¾-inch
1	1-inch
6	1½-inch

Code	Description
2	2-inch
3	3-inch
4	4-inch
X	Special (consult factory)

Process connection rating

Code	Process connection rating	Compatible process connection type
ZZ	Same as instrument rating (Style A only)	Z
AA	ANSI/ASME B16.5 Class 150	1, 2, 3, 4, Y
AB	ANSI/ASME B16.5 Class 300	1, 2, 3, 4, Y
AC	ANSI/ASME B16.5 Class 600	1, 2, 3, 4, Y
AD	ANSI/ASME B16.5 Class 900	1, 2, 3, 4, Y
AE	ANSI/ASME B16.5 Class 1500	1, 2, 3, 4, Y
AF	ANSI/ASME B16.5 Class 2500	1, 2, 3, 4, Y
FA	ANSI/ASME B16.11 Class 3000	A, E, G, H, K, L
FB	ANSI/ASME B16.11 Class 6000	A, E, G, H, K, L
SA	ANSI/ASME B16.9 S10	A, B, L, M, P
SB	ANSI/ASME B16.9 STD (S40)	A, B, L, M, P
SC	ANSI/ASME B16.9 XS (S80)	A, B, C, L, M, P
SD	ANSI/ASME B16.9 S160	A, B, C, L, M, P

Process connection type

Code	Process connection type	Compatible process connection rating
1	RF Weld Neck	AA, AB, AC, AD, AE, AF
2	RF Slip-On	AA, AB, AC, AD, AE, AF
4	RTJ Weld Neck	AA, AB, AC, AD, AE, AF
A	Nipple - Plain end	SA, SB, SC, SD
C	Nipple - Male NPT	SC, SD
E	Coupling - Female NPT	FB
G	Coupling - SW	FA, FB
H	Threadolet NPT	FA, FB
K	Sockolet	FA, FB
L	Weldolet	SA, SB, SC, SD
M	Nipolet - Plain End	SA, SB, SC, SD
P	Nipolet - Beveled End	SA, SB, SC, SD
Y	Raised face lap joint (RFLJ)	AA, AB, AC, AD, AE, AF

Code	Process connection type	Compatible process connection rating
Z	Same as access flange (Style A only)	ZZ

Process connection schedule

Process connection schedule needs to be equal or greater than the chamber schedule.

Code	Description
0	Same schedule as chamber (Style A only)
1	S10
4	S40
8	S80
6	S160

Process connection material

Code	Description
0	Same material as chamber
S	316/316L Stainless steel (standard)
2	321 Stainless steel
7	347 Stainless steel
1	317 Stainless steel
C	Carbon steel
X	Special (consult factory)

Top of the chamber

Code	Description
B	Blind flange
D	Dome cap
F	Flat cap
Z	Open flange (Style A only)
X	Special (consult factory)

Top vent size

Code	Description
0	No top vent (Style A only)
8	½-inch
9	¾-inch

Code	Description
1	1-inch
X	Special (consult factory)

Top vent type

Code	Description
Z	No top vent (Style A only)
A	NPT tap only with plug
C	SW tap only
D	Flanged
F	Coupling - FNPT with plug
H	Coupling - SW
X	Special (consult factory)

Top vent schedule or rating

Code	Description
Z ⁽¹⁾	No top vent (Style A only)
1	S10
4	S40
8	S80
6	S160
3	Class 3000
5	Class 6000

(1) *Must select for Top Vent type Z Option Z.*

Bottom of the chamber

Code	Description
B	Blind flange
D	Dome cap
F	Flat cap
Z	Open flange with stop plate (Style A only)
X	Special (Consult Factory)

Bottom drain size

Code	Description
0	No bottom drain
8	½-inch
9	¾-inch
1	1-inch
X	Special

Bottom drain type

Code	Description
Z	No bottom drain (Style A only)
A	NPT tap only with plug
C	SW tap only
D	Flanged
F	Coupling - FNPT with plug
H	Coupling - SW
X	Special (consult factory)

Bottom drain schedule or rating

Code	Description
Z	No bottom drain (Style A only)
1	S10
4	S40
8	S80
6	S160
3	Class 3000
5	Class 6000

Indicator

Code	Description
F	Flag
B	Follower (birdie/shuttle)

Indicator measuring range

Code	Description
XXXXX	XXX.XX inches or XXXXX mm 04863 = 48.63 inches or 04863 mm

Scale units

Code	Description
Z	Feet and inches (½-inch increments)
A	Metric (5 mm increments)
B	Percentage (custom increments)
C	Inches only (½-inch increments)
D	+/- (custom increments)
E	Dual (feet and inches, percent)
F	Dual (metric, percent)
X	Special

Indicator enclosure material

Code	Description
0	Anodized aluminum housing with glass
1	Anodized aluminum housing with polycarbonate
2	Anodized aluminum housing with acrylic frost extension
3	Stainless steel housing with glass
5	Stainless steel channel with glass tube
6	Stainless steel channel with polycarbonate tube

Indicator color

Code	Description
A	Red and white flags
C	Yellow and black flags
B	Red follower
D	Green follower
Z	Red and silver flags

Indicator mounting

Code	Description
Z	Standard orientation (180° from process connections)

Code	Description
R	Right mount
L	Left mount
C	Customer specified
Typical model number: 9930068BAB1E 06400 SE2AB14SB9C8B9C8F 06400 E3AR	

Order options - must be specified at time of order

Test and inspection	Hydrostatic pressure test certificate Weld inspection NDE (non-destructive examination)
Documentation	Approval and as-built drawings Weld procedures Quality plans Material Traceability Record (MTR) Float curves
Accessories	Valves (vent and drain) Insulation blanket (For elevated temperature) Heat trace (Steam) Heat trace (Electrical) Hard shell cryogenic insulation with frost protection Chamber support clips

Associated products

- Dual chamber unit with Guided Wave Radar
- Magnetic level switches
- Magnetostrictive transmitter

Mounting styles

Figure 2: Mounting Styles

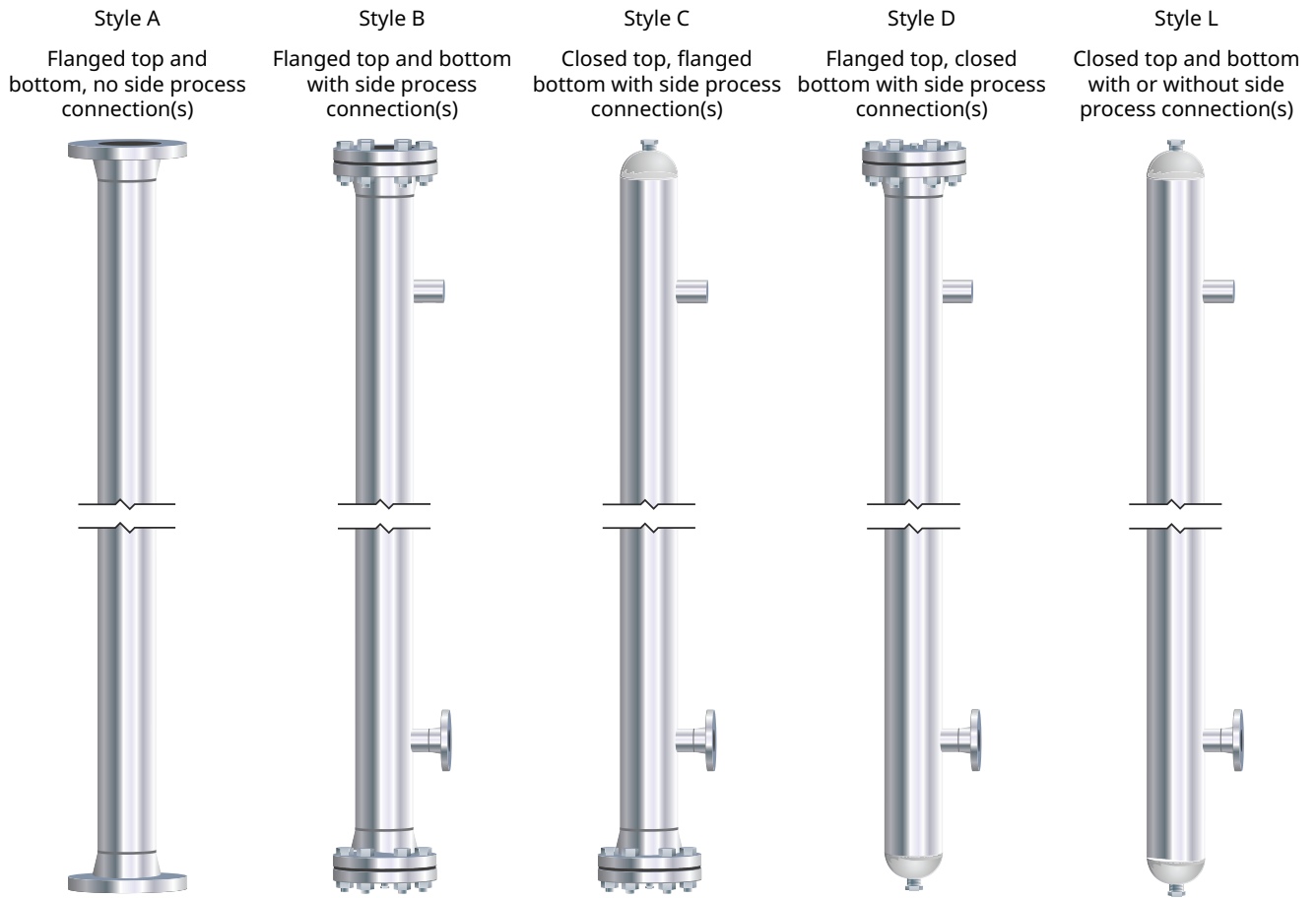

Specifications

Performance specifications

Resolution

Approximately ¼-inch resolution

Measuring range

Maximum mounting dimension per single unit is 20 ft. (6 m) for Style A and 18 ft. (5.5 m) for Style B/C/D.

Maximum viscosity

2000 cP

Minimum Specific Gravity (SG)

0.40 (consult factory for lower specific gravities)

Minimum delta SG

0.11

Functional specifications

Temperature rating

-260 °F to +850 °F (-162 °C to +454 °C)

Float pressure rating

Up to 3400 psig (234.4 bar) at 100 °F (38 °C)

Process connection rating

Process connection style	ANSI/ASME B16.5						ANSI/ASME B16.11		ANSI/ASME B16.9		
	150	300	600	900	1500	2500	3000	6000	STD	S80	S160
RF Weld Neck	X	X	X	X	X	X					
RF Slip-on	X	X	X	X	X	X					
RF Socket Weld	X	X	X	X	X	X					
RTJ Weld Neck	X	X	X	X	X	X					
RF Lap Joint (RFLJ)	X	X									
Coupling - Female NPT							X	X			
Coupling - SW							X	X			
Pipe Nipple									X	X	X

Visual indicator

Visible from 100 ft. (30 m)

Indicator options

- Flag (standard)
- Follower (optional)

Physical specifications

Material selection

Emerson provides a variety of products with various product options and configurations including materials of construction ensuring optimal performance in a wide range of applications. The product information presented is intended to be a guide for the purchaser to make an appropriate selection for the application. It is the purchaser's sole responsibility to make a careful analysis of all process parameters (such as all chemical components, temperature, pressure, flow rate, abrasives, contaminants, etc.), when specifying product, materials, options and components for the particular application. Emerson is not in a position to evaluate or guarantee the compatibility of the process fluid or other process parameters with the product, options, configuration or materials of construction selected.

Chamber design

Welding and welder qualification in accordance with ASME Section IX.

- ASME B31.3
- ASME B31.1 (optional)
- CRN Registration (all provinces)

Process connection sizes

½-inch to 4-inch

Materials of construction

Chamber

- 300 Series stainless steel (standard 316/316L)
- Optional: Other non-ferrous materials that do not exhibit ferro-magnetic properties such as Alloy C-276, Alloy 20, Alloy 600, Alloy 400, and CPVC.

Float

- 316 stainless steel
- Titanium
- Alloy 400
- Alloy C-276
- CPVC
- Special options: PTFE coating

Indicator viewing window

Glass or polycarbonate

Gasket

All gauges are shipped complete with 0.125-inch composition gaskets for protection of flanges. Customer is responsible for process compatible gaskets for protection of flanges.

Note

If composition gaskets are not compatible with your process conditions, appropriate gaskets should be used in place of those shipped with the gauge.

Dimensional drawings

Figure 3: Standard MLI - style A

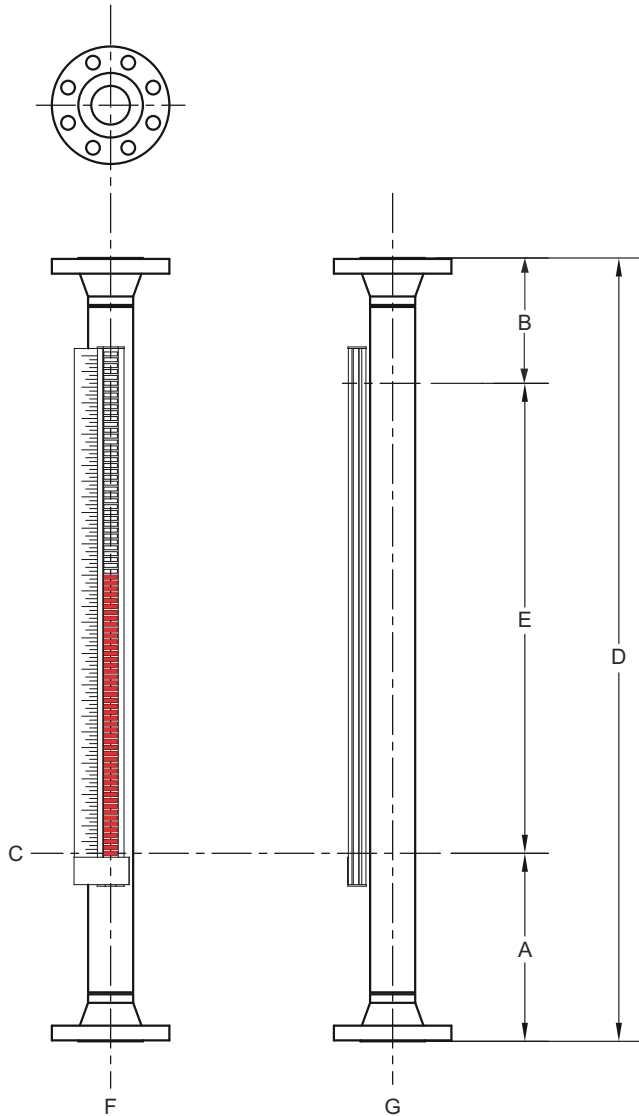

- A. See [Configuration Data Sheet](#) for information.
- B. See [Configuration Data Sheet](#) for information.
- C. Datum
- D. Mounting dimension
- E. Measuring range
- F. Front view
- G. Right side view

Note

For reference use only. Do not use for construction purposes or as built unless certified by Rosemount. Drawing is generic - see [Rosemount 9930 Magnetic Level Indicator \(MLI\) ordering information](#) for detailed options.

Figure 4: Standard MLI - style B

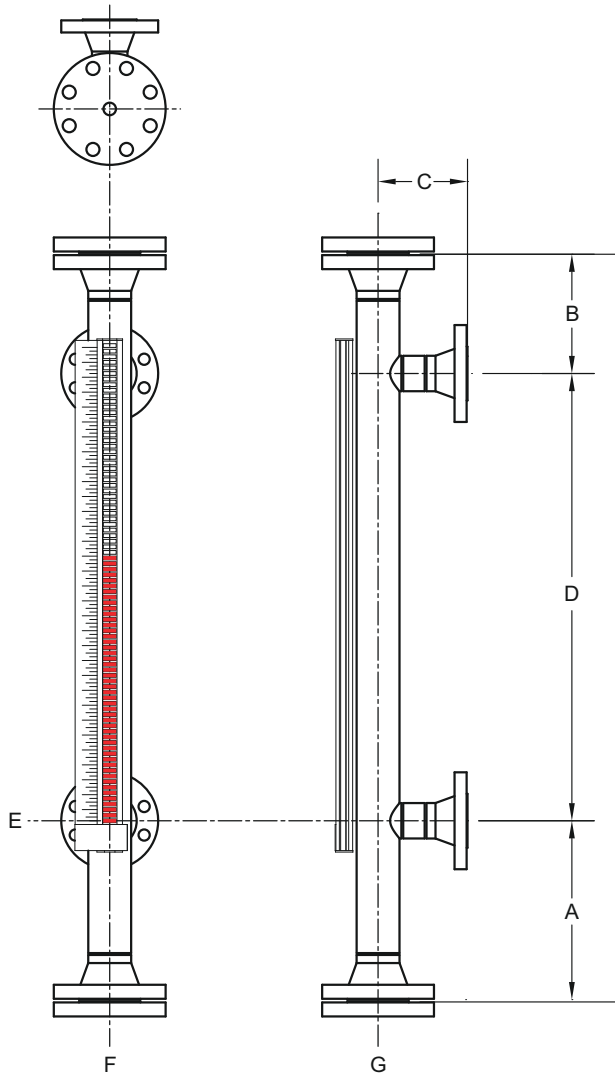

- A. See [Configuration Data Sheet](#) for information.
- B. See [Configuration Data Sheet](#) for information.
- C. See [Configuration Data Sheet](#) for information.
- D. Mounting dimension (center-to-center)
- E. Datum
- F. Front view
- G. Right side view

Note

For reference use only. Do not use for construction purposes or as built unless certified by Rosemount. Drawing is generic - see [Rosemount 9930 Magnetic Level Indicator \(MLI\) ordering information](#) for detailed options.

Figure 5: Standard MLI - style C

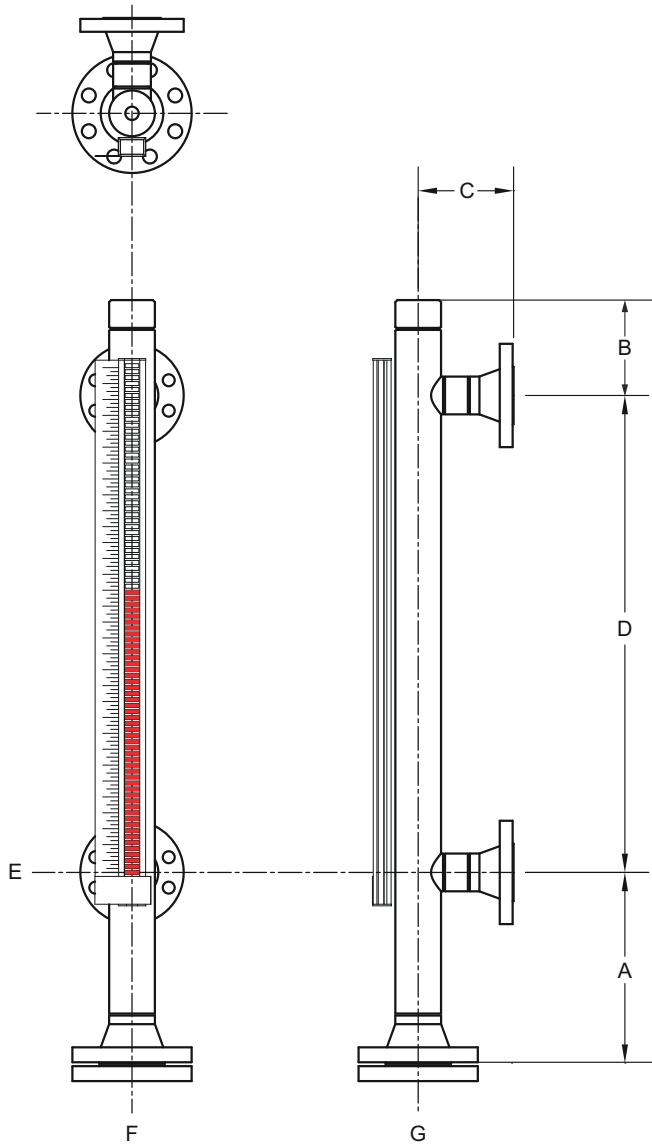

- A. See [Configuration Data Sheet](#) for information.
- B. See [Configuration Data Sheet](#) for information.
- C. See [Configuration Data Sheet](#) for information.
- D. Mounting dimension (center-to-center)
- E. Datum
- F. Front view
- G. Right side view

Note

For reference use only. Do not use for construction purposes or as built unless certified by Rosemount. Drawing is generic - see [Rosemount 9930 Magnetic Level Indicator \(MLI\) ordering information](#) for detailed options.

Figure 6: Standard MLI - style D

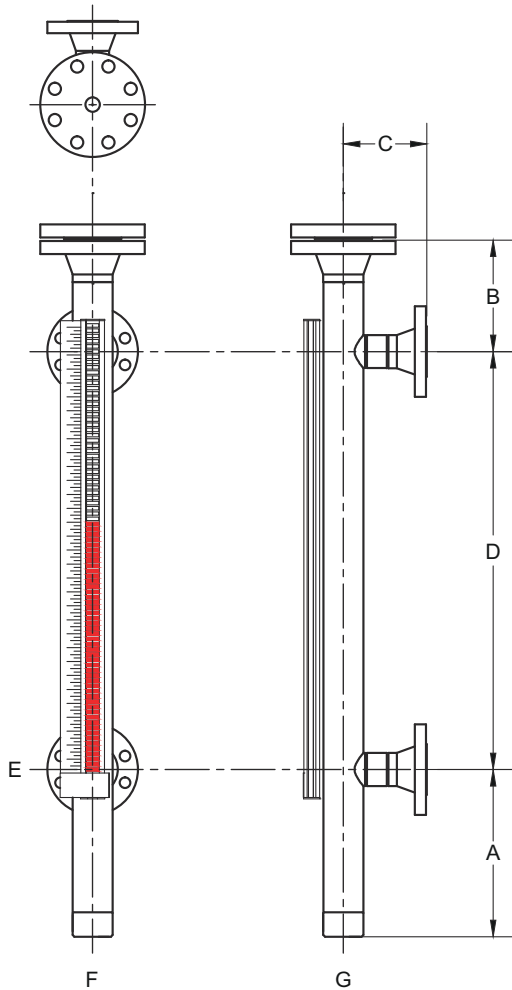

- A. See [Configuration Data Sheet](#) for information.
- B. See [Configuration Data Sheet](#) for information.
- C. See [Configuration Data Sheet](#) for information.
- D. Mounting dimension (center-to-center)
- E. Datum
- F. Front view
- G. Right side view

Note

For reference use only. Do not use for construction purposes or as built unless certified by Rosemount. Drawing is generic - see [Rosemount 9930 Magnetic Level Indicator \(MLI\) ordering information](#) for detailed options.

Figure 7: Standard MLI - style L

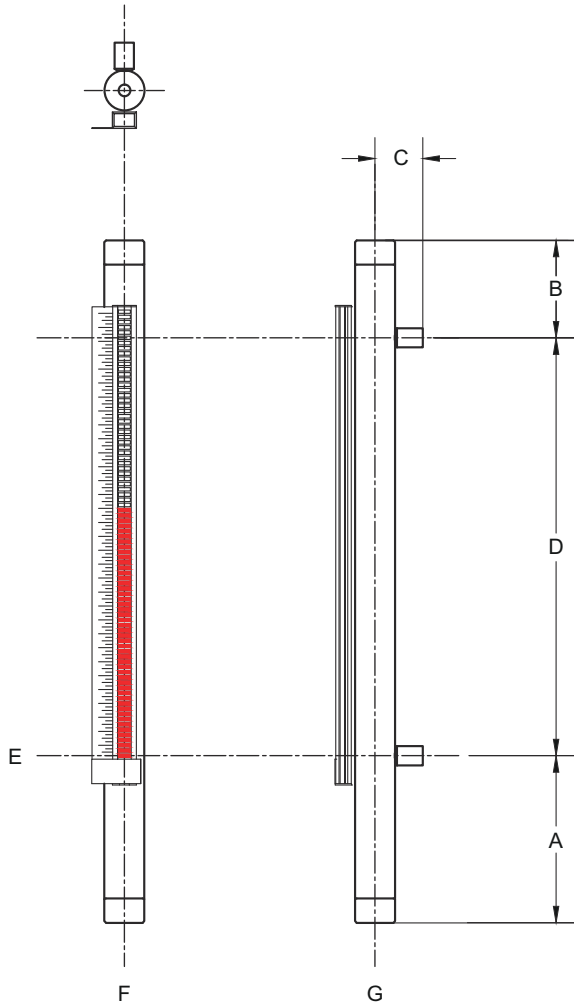

- A. See [Configuration Data Sheet](#) for information.
- B. See [Configuration Data Sheet](#) for information.
- C. See [Configuration Data Sheet](#) for information.
- D. Mounting dimension (center-to-center)
- E. Datum
- F. Front view
- G. Right side view

Note

For reference use only. Do not use for construction purposes or as built unless certified by Rosemount. Drawing is generic - see [Rosemount 9930 Magnetic Level Indicator \(MLI\) ordering information](#) for detailed options.

For more information: [Emerson.com/global](https://emerson.com/global)

©2025 Emerson. All rights reserved.

Emerson Terms and Conditions of Sale are available upon request. The Emerson logo is a trademark and service mark of Emerson Electric Co. Rosemount is a mark of one of the Emerson family of companies. All other marks are the property of their respective owners.

ROSEMOUNT™

