

# Rosemount™ 5900C Radar Level Gauge

Reliable level measurement



- Get the highest reliability for monitoring bulk liquids
- Certified IEC 61508 SIL 2 capable
- Measures level with  $\pm 1$  mm (0.04 in.) instrument accuracy
- Bus powered for convenient and safe 2-wire installation
- Full functionality, wired or wireless
- No need to take non-pressurized tanks out of service during installation

# Improve plant efficiency and safety

## The highest reliability for your bulk liquid storage tanks

The Rosemount 5900C level gauge with its non-contact radar measurement method ensures state-of-the-art reliability.

- No moving parts
- Less maintenance
- Reliable loss control data

The Rosemount 5900C is normally combined with multiple spot temperature sensors for API standard net volume calculations. It measures level in all bulk storage tank types and products, ranging from liquefied gases, light products, heavy fuel oil, and bitumen.

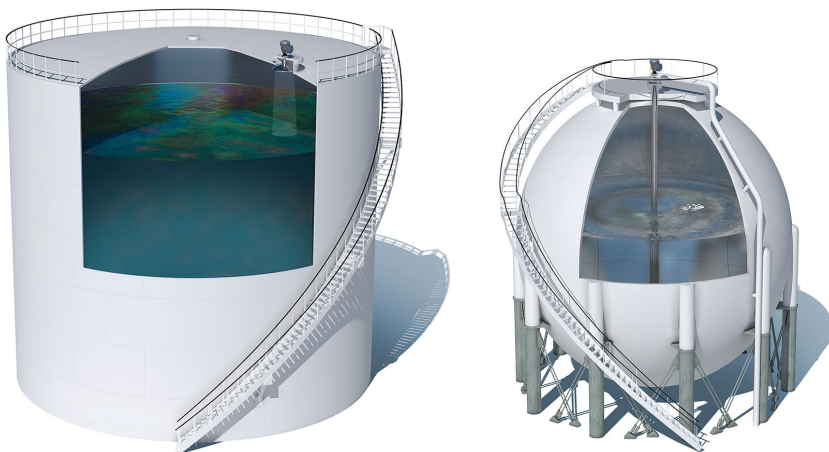

## More efficient operations

- Fewer interruptions and slow-downs
- Most Rosemount 5900C antenna types are installed with the tanks in operation
- Emerson wireless solution can drastically reduce installation cost and give you access to remote tanks
- The Rosemount 5900C is an integrated part of complete tank gauging solutions from Emerson, who has supplied tank gauging for more than 100 000 bulk liquid storage tanks

## Taking overfill safety to a higher level

- Certified SIL 2 capable safety according to IEC 61508
- Enables API 2350 compliant solutions

---

## Contents

Improve plant efficiency and safety.....	2
Get complete level and inventory information.....	3
Ordering information.....	5
Specifications.....	29
Product certifications.....	43
Dimensional drawings.....	44

## Get complete level and inventory information

The Rosemount 5900C Radar Level Gauge is normally integrated into a complete tank gauging system including average temperature measurement for net volume calculation. See also Rosemount Tank Gauging [System Data Sheet \(SDS\)](#).

Data can be displayed remotely, on a host computer or the TankMaster™ inventory software package. In most cases measurement data is transmitted to the control room via TRL2 Modbus® communication from the tank hub. As an alternative, data can be transmitted via FOUNDATION™ Fieldbus communication directly from the gauge to the control room, without using the tank hub.

**Figure 1: Tank Gauging System Overview**

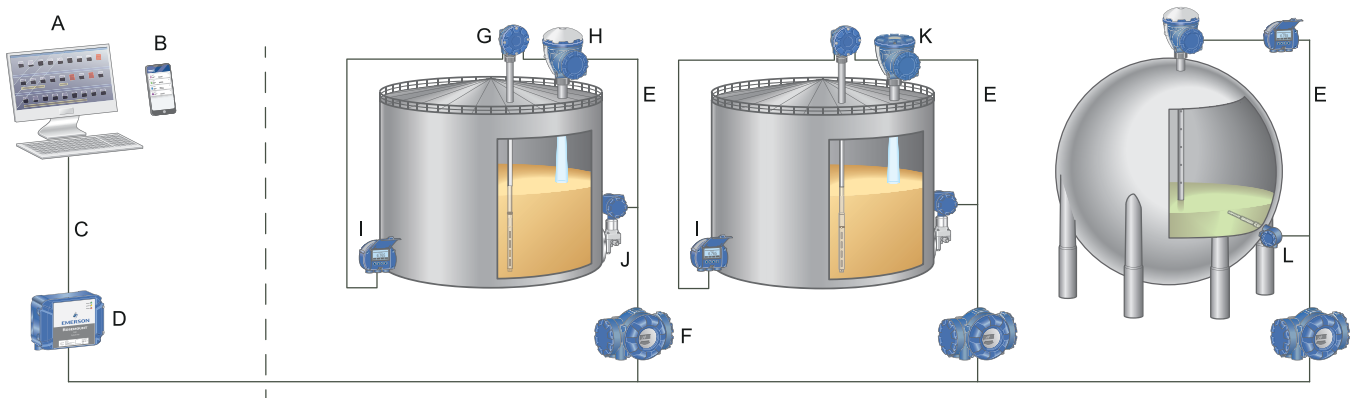

- A. Rosemount TankMaster Inventory Management
- B. Rosemount TankMaster Mobile Inventory Management
- C. Modbus® RTU/TCP
- D. Rosemount 2460 System Hub
- E. Tankbus
- F. Rosemount 2410 Tank Hub
- G. Rosemount 2240S Multi-input Temperature Transmitter with Rosemount 765 Multiple Spot Temperature and Water Level Sensor
- H. Rosemount 5900S Radar Level Gauge
- I. Rosemount 2230 Graphical Field Display
- J. Rosemount 3051S Pressure Transmitter
- K. Rosemount 5900C Radar Level Gauge
- L. Rosemount 3144P Temperature Transmitter with Rosemount 114C or 214C Single Point Temperature Sensor

The Rosemount 5900C is optimized for medium to high accuracy applications. For highest precision, we recommend the Rosemount 5900S Radar Level Gauge.

With Rosemount's proprietary emulation technology, tank gauging devices can be cost-effectively added to an existing system using the previous vendor's communication protocol.

Using an Emerson wireless solution is an alternative that saves installation cost and enables full tank gauging functionality for remote tanks where long distance field wiring is obsolete.

**Drip-off means no condensation**

Since the antenna has an inclined polished PTFE surface where microwaves are emitted, it is less susceptible to condensed water or product. Condensation drops do not coat the active antenna part, so the radar signal remains strong, resulting in higher accuracy and better reliability.

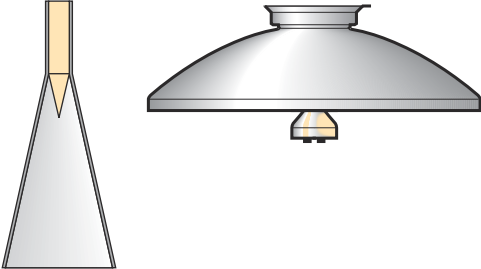
**Access information when you need it with asset tags**

Newly shipped devices include a unique QR code asset tag that enables you to access serialized information directly from the device. With this capability, you can:

- Access device drawings, diagrams, technical documentation, and troubleshooting information in your MyEmerson account.
- Improve mean time to repair and maintain efficiency.
- Ensure confidence that you have located the correct device.
- Eliminate the time-consuming process of locating and transcribing nameplates to view asset information.



## Rosemount 5900C Radar Level Gauge with parabolic antenna



Rosemount 5900C with parabolic antenna is a non-contact radar level gauge. The parabolic antenna is the first choice for installation on tanks with fixed roofs without a still-pipe. It can be installed on existing manhole covers and close to the tank wall due to the narrow radar beam and high signal to noise ratio. In certain cases, it can be used on tanks with floating roofs to measure the distance down to a target plate on the floating roof.

- Measures all products ranging from light products to heavy fuel oil, bitumen and asphalt
- Antenna design gives extreme tolerance to product build-up and condensation
- Certified SIL 2 capable according to IEC 61508
- Communicates via a 2-wire, low voltage Tankbus for easy and safe installation
- Installation normally with tank in service

[VIEW PRODUCT >](#)

### Required model components

#### Model

Code	Description
5900C	Radar Level Gauge

#### Performance class

Code	Description
1	±1 mm (0.04 in.) instrument accuracy
2	±2 mm (0.08 in.) instrument accuracy

#### Safety certification (SIS)

Code	Description
S <sup>(1)</sup>	Certified IEC 61508 SIL 2 capable
F	None. Ready for upgrade to Safety certification (SIS)
0	None

(1) Requires Rosemount 2410 with either Analog output 4-20 mA or Relay output code 1 or 2.

#### Redundancy

Code	Description
1	None. Single radar level gauge electronics

#### Tankbus: Power and communication

Code	Description
F	Bus powered 2-wire FOUNDATION™ Fieldbus (IEC 61158)

**Hazardous location certification**

Code	Description
I1	ATEX Intrinsic Safety
I7	IECEX Intrinsic Safety
I5	FM-US Intrinsic Safety
I6	FM-Canada Intrinsic Safety
I2	INMETRO Intrinsic Safety (Brazil)
IP	KC Intrinsic Safety (South Korea)
IW	CCOE/PESO Intrinsic Safety (India)
I3	NEPSI Intrinsic Safety (China)
I4 <sup>(1)</sup>	Japan Intrinsic Safety
IM	Technical Regulations Customs Union (EAC) Intrinsic Safety
NA	None

(1) Not available with Cable entry/Conduit connections code E or M.

**Custody transfer type approval**

Code	Description
0	None

**Level measurement method**

Code	Description
1	10 GHz FMCW radar technology
2	10 GHz FMCW radar technology for US installation

**Housing**

Code	Description
A	Standard enclosure, polyurethane-covered aluminum. IP 66/67

**Cable entry/Conduit connections**

Code	Description
1	½ - 14 NPT, female thread. (1 plug included)
2	M20 x 1.5 adapters, female thread. (2 adapters and 1 plug included)
G	Metal cable glands (½ - 14 NPT). Minimum temperature -20 °C (-4 °F). ATEX/IECEX Exe approved. (2 glands and 1 plug included)
E	eurofast® male connector (1 plug included)
M	minifast® male connector (1 plug included)

**Antenna**

Code	Description
1P	Parabolic antenna

**Antenna size**

Code	Description
F	20 in./DN 500, Ø=440 mm (17.3 in.)

**Antenna material**

Code	Description
S	SST AISI 316L/EN 1.4436

**Tank seal**

Code	Description
PF	PTFE with FEP fluoropolymer O-ring
PK	PTFE with Kalrez® perfluoroelastomer O-ring

**Tank connection**

Code	Description
WE	Welded installation
CL	Clamped/threaded installation

**Antenna options**

Code	Description
0	None
V <sup>(1)</sup>	Proof test verification reflector

(1) Not available with Options code U1.

**Additional options****Safety certificate**

Requires Safety certification (SIS) code S.

Code	Description
QT	IEC 61508 certificate and FMEDA-data (printed copy)

**Calibration certificate**

Code	Description
Q4	Calibration certificate (tank height up to 30 m (100 ft), printed copy)
QL	Calibration certificate 40 m (tank height up to 40 m (130 ft), printed copy)

**Material traceability certificate**

Not available for transmitter head sparepart.

Code	Description
Q8	Antenna material traceability certification per EN 10204 3.1

**Conformance certificate**

Code	Description
Q1	Certificate of conformance

**Overfill protection approval**

Code	Description
U1 <sup>(1)</sup>	TÜV/DIBt WHG approval for overfill protection
U2	SVTI approval for overfill protection (Switzerland)

(1) *Requires one or more relay outputs in the Rosemount 2410 Tank Hub.*

**Tag plate**

Code	Description
ST	Engraved SST tag plate (tag shall be submitted with order)

**Extended product warranty**

Rosemount extended warranties have a limited warranty of three or five years from date of shipment.

Code	Description
WR3	3-year limited warranty
WR5	5-year limited warranty

## Rosemount 5900C Radar Level Gauge with cone antenna



Rosemount 5900C with cone antenna is a non-contact radar level gauge. It is designed for easy installation on fixed roofs tanks, with smaller nozzles.

- Communicates via a 2-wire, intrinsically safe Tankbus for easy and safe installation
- Installation normally with tank in service
- Measures on a variety of products except asphalt or similar for which the parabolic antenna is recommended

[VIEW PRODUCT >](#)

### Required model components

#### Model

Code	Description
5900C	Radar Level Gauge

#### Performance class

Code	Description
2	±2 mm (0.08 in.) instrument accuracy

#### Safety certification (SIS)

Code	Description
S <sup>(1)</sup>	Certified IEC 61508 SIL 2 capable
F	None. Ready for upgrade to Safety certification (SIS)
0	None

(1) Requires Rosemount 2410 with either Analog output 4-20 mA or Relay output code 1 or 2.

#### Redundancy

Code	Description
1	None. Single radar level gauge electronics

**Tankbus: Power and communication**

Code	Description
F	Bus powered 2-wire FOUNDATION™ Fieldbus (IEC 61158)

**Hazardous location certification**

Code	Description
I1	ATEX Intrinsic Safety
I7	IECEx Intrinsic Safety
I5	FM-US Intrinsic Safety
I6	FM-Canada Intrinsic Safety
I2	INMETRO Intrinsic Safety (Brazil)
IP	KC Intrinsic Safety (South Korea)
IW	CCOE/PESO Intrinsic Safety (India)
I3	NEPSI Intrinsic Safety (China)
I4 <sup>(1)</sup>	Japan Intrinsic Safety
IM	Technical Regulations Customs Union (EAC) Intrinsic Safety
NA	None

(1) Not available with Cable entry/Conduit connections code E or M.

**Custody transfer type approval**

Code	Description
0	None

**Level measurement method**

Code	Description
1	10 GHz FMCW radar technology
2	10 GHz FMCW radar technology for US installation

**Housing**

Code	Description
A	Standard enclosure, polyurethane-covered aluminum. IP 66/67

**Cable entry/Conduit connections**

Code	Description
1	½ - 14 NPT, female thread. (1 plug included)
2	M20 x 1.5 adapters, female thread. (2 adapters and 1 plug included)
G	Metal cable glands (½ - 14 NPT). Minimum temperature -20 °C (-4 °F). ATEX/IECEx Exe approved. (2 glands and 1 plug included)
E	euromast® male connector (1 plug included)
M	minifast® male connector (1 plug included)

**Antenna**

Code	Description
1C	Cone antenna

**Antenna size**

Code	Description
4	4 in. / DN 100, Ø=93 mm (3.7 in.)
6 <sup>(1)</sup>	6 in. / DN 150, Ø=141 mm (5.6 in.)
8 <sup>(1)</sup>	8 in. / DN 200, Ø=189 mm (7.4 in.)
X	Customer-specific, consult factory

(1) Only for free propagation installations.

**Antenna material**

Code	Description
S	SST AISI 316/316L and SST EN 1.4401/1.4404
X	Customer-specific, consult factory

**Tank seal**

Code	Description
PV	PTFE with Viton® fluoroelastomer O-rings
PK	PTFE with Kalrez® perfluoroelastomer O-rings
QV	Quartz with Viton® fluoroelastomer O-rings
QK	Quartz with Kalrez® perfluoroelastomer O-rings

**Tank connection**

Code	Description
ANSI Hole Pattern (SST AISI 316 L) – Flat Face <sup>(1)</sup>	
6T	6 in. Class 150
8T	8 in. Class 150
EN Hole Pattern (SST EN 1.4404) – Flat Face <sup>(1)</sup>	
KT	DN 150/PN 16
MT	DN 200/PN 10
ANSI flanges (SST AISI 316 L) – Raised Face	
4A	4 in. Class 150
4B	4 in. Class 300
6A	6 in. Class 150
8A	8 in. Class 150
EN flanges (SST EN 1.4404) – Flat Face	
JA	DN 100 PN 16
JB	DN 100 PN 40

Code	Description
KA	DN 150 PN 16
LA	DN 200 PN 16
Other	
00	None
XX	Customer-specific, consult factory.

(1) *Thin flange for non-pressurized applications, max pressure 0,2 bar (2.9 psi).*

### Antenna options

Code	Description
0	None
1 <sup>(1)</sup>	Extended Cone Antenna, total length 20 in. (500 mm).
X	Customer-specific, consult factory.

(1) *Requires Antenna size code 4 or 6.*

## Additional options

### Safety certificate

Requires Safety certification (SIS) code S.

Code	Description
QT	IEC 61508 certificate and FMEDA-data (printed copy)

### Calibration certificate

Code	Description
Q4	Calibration certificate (printed copy)

### Material traceability certificate

Not available for transmitter head sparepart.

Code	Description
Q8	Antenna material traceability certification per EN 10204 3.1

### Conformance certificate

Code	Description
Q1	Certificate of conformance

### Overfill protection approval

Code	Description
U1 <sup>(1)</sup>	TÜV/DIBt WHG approval for overfill protection
U2	SVTI approval for overfill protection (Switzerland)

(1) *Requires one or more relay outputs in the Rosemount 2410 Tank Hub.*

**Tag plate**

<b>Code</b>	<b>Description</b>
ST	Engraved SST tag plate (tag shall be submitted with order)

**Extended product warranty**

Rosemount extended warranties have a limited warranty of three or five years from date of shipment.

<b>Code</b>	<b>Description</b>
WR3	3-year limited warranty
WR5	5-year limited warranty

## Rosemount 5900C Radar Level Gauge with still-pipe array antenna



The Rosemount 5900C with array antenna is a non-contact radar level gauge for still-pipe measurement. It is available in two versions, fixed and hinged hatch. Typical applications are crude oil tanks with floating roofs and gasoline/product tanks with or without inner floating roofs.

- Suitable for crude oil, gasoline or similar products. For Methanol please consult factory.
- Certified SIL 2 capable according to IEC 61508
- Tolerant against rust and product deposits inside the pipe
- Communicates via a 2-wire, low voltage Tankbus for easy and safe installation
- Hinged hatch version enables easier product sampling and hand-dips
- Installation normally with tank in service

[VIEW PRODUCT >](#)

### Required model components

#### Model

Code	Description
5900C	Radar Level Gauge

#### Performance class

Code	Description
1	±1 mm (0.04 in.) instrument accuracy
2	±2 mm (0.08 in.) instrument accuracy

#### Safety certification (SIS)

Code	Description
S <sup>(1)</sup>	Certified IEC 61508 SIL 2 capable
F	None. Ready for upgrade to Safety certification (SIS)
0	None

(1) Requires Rosemount 2410 with either Analog output 4-20 mA or Relay output code 1 or 2.

#### Redundancy

Code	Description
1	None. Single radar level gauge electronics

#### Tankbus: Power and communication

Code	Description
F	Bus powered 2-wire FOUNDATION™ Fieldbus (IEC 61158)

**Hazardous location certification**

Code	Description
I1	ATEX Intrinsic Safety
I7	IECEx Intrinsic Safety
I5	FM-US Intrinsic Safety
I6	FM-Canada Intrinsic Safety
I2	INMETRO Intrinsic Safety (Brazil)
IP	KC Intrinsic Safety (South Korea)
IW	CCOE/PESO Intrinsic Safety (India)
I3	NEPSI Intrinsic Safety (China)
I4 <sup>(1)</sup>	Japan Intrinsic Safety
IM	Technical Regulations Customs Union (EAC) Intrinsic Safety
NA	None

(1) Not available with Cable entry/Conduit connections code E or M.

**Custody transfer type approval**

Code	Description
0	None

**Level measurement method**

Code	Description
1	10 GHz FMCW radar technology
2	10 GHz FMCW radar technology for US installation

**Housing**

Code	Description
A	Standard enclosure, polyurethane-covered aluminum. IP 66/67

**Cable entry/Conduit connections**

Code	Description
1	½ - 14 NPT, female thread. (1 plug included)
2	M20 x 1.5 adapters, female thread. (2 adapters and 1 plug included)
G	Metal cable glands (½ - 14 NPT). Minimum temperature -20 °C (-4 °F). ATEX/IECEx Exe approved. (2 glands and 1 plug included)
E	euromast® male connector (1 plug included)
M	minifast® male connector (1 plug included)

**Antenna**

Code	Description
1A	Still-pipe array antenna

**Antenna size**

Code	Description
5	5 in./DN 125, Ø=120 mm (4.7 in.)
6	6 in./DN 150, Ø=145 mm (5.7 in.)
8	8 in./DN 200, Ø=189 mm (7.4 in.)
A	10 in./DN 250, Ø=243 mm (9.8 in.)
B	12 in./DN 300, Ø=293 mm (11.8 in.)

**Antenna material**

Code	Description
S	SST (AISI 316L / EN 1.4404) and PPS (polyphenylene sulfide)

**Tank seal**

Code	Description
FF	Fixed flange installation with fluorosilicone O-ring
FK	Fixed flange installation with Kalrez® perfluoroelastomer O-ring
HH	Integrated hatch installation with fluorosilicone tank seal O-ring, and Viton® hatch O-ring (direct access to pipe with hand gauge)

**Tank connection**

Code	Description
ANSI Hole Pattern (SST AISI 316/316 L) – Flat Face	
5A	5 in. Class 150
6A	6 in. Class 150
8A	8 in. Class 150
AA	10 in. Class 150
BA	12 in. Class 150
EN Hole Pattern (SST EN 1.4404) – Flat Face	
KA	DN 150 PN 16
LA	DN 200 PN 10
MB	DN 250 PN 16

**Antenna options**

Code	Description
0	None
C	Clamp flange (for still-pipes without a flange). Available for 6, 8, 10, and 12 in. tank connections.
V <sup>(1)(2)</sup>	Proof test verification reflector (size equal to Tank connection)

(1) Requires Antenna size code 6, 8, A, or B.

(2) Not available with Options code U1.

## Additional options

### Safety certificate

Requires Safety certification (SIS) code S.

Code	Description
QT	IEC 61508 certificate and FMEDA-data (printed copy)

### Calibration certificate

Code	Description
Q4	Calibration certificate (tank height up to 30 m (100 ft), printed copy)
QL	Calibration certificate 40 m (tank height up to 40 m (130 ft), printed copy)

### Material traceability certificate

Not available for transmitter head sparepart.

Code	Description
Q8	Antenna material traceability certification per EN 10204 3.1

### Conformance certificate

Code	Description
Q1	Certificate of conformance

### Overfill protection approval

Code	Description
U1 <sup>(1)</sup>	TÜV/DIBt WHG approval for overfill protection
U2	SVTI approval for overfill protection (Switzerland)

(1) Requires one or more relay outputs in the Rosemount 2410 Tank Hub.

### Tag plate

Code	Description
ST	Engraved SST tag plate (tag shall be submitted with order)

### Extended product warranty

Rosemount extended warranties have a limited warranty of three or five years from date of shipment.

Code	Description
WR3	3-year limited warranty
WR5	5-year limited warranty

## Rosemount 5900C Radar Level Gauge with LPG/LNG antenna



The Rosemount 5900C with LPG/LNG antenna is a non-contact radar level gauge for measurement on pressurized or cryogenic liquefied gas. Radar signals are transmitted inside the still-pipe which enables the gauge to have a sufficiently strong echo even under turbulent conditions, such as a boiling surface.

- Certified SIL 2 capable according to IEC 61508
- Reference device function enables measurement verification with the tank in service
- Communicates via a 2-wire, low voltage Tankbus for easy and safe installation
- Built-in pressure sensor for vapor compensation gives best measurement performance
- Integrated ball valve

[VIEW PRODUCT >](#)

### Required model components

#### Model

Code	Description
5900C	Radar Level Gauge

#### Performance class

Code	Description
1	±1 mm (0.04 in.) instrument accuracy
2	±2 mm (0.08 in.) instrument accuracy

**Safety certification (SIS)**

Code	Description
S <sup>(1)</sup>	Certified IEC 61508 SIL 2 capable
F	None. Ready for upgrade to Safety certification (SIS)
0	None

(1) Requires Rosemount 2410 with either Analog output 4-20 mA or Relay output code 1 or 2.

**Redundancy**

Code	Description
1	None. Single radar level gauge electronics

**Tankbus: Power and communication**

Code	Description
F	Bus powered 2-wire FOUNDATION™ Fieldbus (IEC 61158)

**Hazardous location certification**

Code	Description
I1	ATEX Intrinsic Safety
I7	IECEx Intrinsic Safety
I5	FM-US Intrinsic Safety
I6	FM-Canada Intrinsic Safety
I2	INMETRO Intrinsic Safety (Brazil)
IP	KC Intrinsic Safety (South Korea)
IW	CCOE/PESO Intrinsic Safety (India)
I3	NEPSI Intrinsic Safety (China)
I4 <sup>(1)</sup>	Japan Intrinsic Safety
IM	Technical Regulations Customs Union (EAC) Intrinsic Safety
NA	None

(1) Not available with Cable entry/Conduit connections code E or M.

**Custody transfer type approval**

Code	Description
0	None

**Level measurement method**

Code	Description
1	10 GHz FMCW radar technology
2	10 GHz FMCW radar technology for US installation

**Housing**

Code	Description
A	Standard enclosure, polyurethane-covered aluminum. IP 66/67

**Cable entry/Conduit connections**

Code	Description
1	½ - 14 NPT, female thread. (1 plug included)
2	M20 x 1.5 adapters, female thread. (2 adapters and 1 plug included)
G	Metal cable glands (½ - 14 NPT). Minimum temperature -20 °C (-4 °F). ATEX/IECEX Exe approved. (2 glands and 1 plug included)
E	eurofast® male connector (1 plug included)
M	minifast® male connector (1 plug included)

**Antenna**

Code	Description
G1	LPG/LNG (liquefied gas) still-pipe antenna (with integrated ball-valve, without pressure transmitter)
G2 <sup>(1)</sup>	LPG/LNG (liquefied gas) still-pipe antenna (with integrated ball-valve and pressure transmitter)

(1) Requires Hazardous location certification code I1, I2, I5, I6, I7, IP, I4, or IM.

**Related information**

[Rosemount 5900C with LPG/LNG antenna](#)

**Antenna size**

Code	Description
A	4 in. Schedule 10, Ø=107 mm (4.2 in.)
B	4 in. Schedule 40, Ø=101 mm (4.0 in.)
D	DN 100, Ø=99 mm (3.9 in.)
G	6 in. Schedule 10, Ø=159 mm (6.3 in.)
H	6 in. Schedule 40 / DN150, Ø=153 mm (6.0 in.)

**Antenna material**

Code	Description
S	SST AISI 316/316L and SST EN1.4401/1.4404

**Tank seal**

Code	Description
PT	PTFE sealing

**Tank connection**

Code	Description
ANSI Flanges (SST AISI 316/316 L) – Raised Face	
1B <sup>(1)</sup>	1.5 in. Class 300
2A <sup>(1)</sup>	2 in. Class 150
2B <sup>(1)</sup>	2 in. Class 300
3A <sup>(1)</sup>	3 in. Class 150
3B <sup>(1)</sup>	3 in. Class 300
4A	4 in. Class 150
4B	4 in. Class 300
6A	6 in. Class 150
6B	6 in. Class 300
8A	8 in. Class 150
8B	8 in. Class 300
EN Hole Pattern (SST EN 1.4404 ) – Raised Face B1	
NA	DN 100 PN40
OA	DN 150 PN40
PA	DN 200 PN25
PB	DN 200 PN40

(1) Requires Antenna size code A.

**Antenna options**

Code	Description
V	Measurement verification kit with 1 verification pin and 1 pipe end deflector kit

**Additional options**

**Safety certificate**

Requires Safety certification (SIS) code S.

Code	Description
QT	IEC 61508 certificate and FMEDA-data (printed copy)

**Calibration certificate**

Code	Description
Q4	Calibration certificate (tank height up to 30 m (100 ft), printed copy)
QL	Calibration certificate 40 m (tank height up to 40 m (130 ft), printed copy)

**Material traceability certificate**

Not available for transmitter head sparepart.

Code	Description
Q8	Antenna material traceability certification per EN 10204 3.1

**Conformance certificate**

Code	Description
Q1	Certificate of conformance

**Overfill protection approval**

Code	Description
U1 <sup>(1)</sup>	TÜV/DIBt WHG approval for overfill protection
U2	SVTI approval for overfill protection (Switzerland)

(1) *Requires one or more relay outputs in the Rosemount 2410 Tank Hub.*

**Tag plate**

Code	Description
ST	Engraved SST tag plate (tag shall be submitted with order)

**Hydrostatic pressure test**

Code	Description
P1	Antenna hydrostatic pressure testing

**Extended product warranty**

Rosemount extended warranties have a limited warranty of three or five years from date of shipment.

Code	Description
WR3	3-year limited warranty
WR5	5-year limited warranty

## Rosemount 5900C Radar Level Gauge with 1- and 2-in. still-pipe antenna

The 1- and 2-in. still-pipe gauges are suitable for clean liquids only and can be delivered complete with still-pipe, deflection plate, and fittings without any need for welding.

[VIEW PRODUCT >](#)

### Required model components

#### Model

Code	Description
5900C	Radar Level Gauge

#### Performance class

Code	Description
2	±2 mm (0.08 in.) instrument accuracy

#### Safety certification (SIS)

Code	Description
S <sup>(1)</sup>	Certified IEC 61508 SIL 2 capable
F	None. Ready for upgrade to Safety certification (SIS)
0	None

(1) Requires Rosemount 2410 with either Analog output 4-20 mA or Relay output code 1 or 2.

#### Redundancy

Code	Description
1	None. Single radar level gauge electronics

#### Tankbus: Power and communication

Code	Description
F	Bus powered 2-wire FOUNDATION™ Fieldbus (IEC 61158)

#### Hazardous location certification

Code	Description
I1	ATEX Intrinsic Safety
I7	IECEX Intrinsic Safety
I5	FM-US Intrinsic Safety
I6	FM-Canada Intrinsic Safety
I2	INMETRO Intrinsic Safety (Brazil)
IP	KC Intrinsic Safety (South Korea)
IW	CCOE/PESO Intrinsic Safety (India)
I3	NEPSI Intrinsic Safety (China)

Code	Description
I4 <sup>(1)</sup>	Japan Intrinsic Safety
IM	Technical Regulations Customs Union (EAC) Intrinsic Safety
NA	None

(1) Not available with Cable entry/Conduit connections code E or M.

### Custody transfer type approval

Code	Description
0	None

### Level measurement method

Code	Description
1	10 GHz FMCW radar technology
2	10 GHz FMCW radar technology for US installation

### Housing

Code	Description
A	Standard enclosure, polyurethane-covered aluminum. IP 66/67

### Cable entry/Conduit connections

Code	Description
1	½ - 14 NPT, female thread. (1 plug included)
2	M20 x 1.5 adapters, female thread. (2 adapters and 1 plug included)
G	Metal cable glands (½ - 14 NPT). Minimum temperature -20 °C (-4 °F). ATEX/IECEX Exe approved. (2 glands and 1 plug included)
E	eurofast <sup>®</sup> male connector (1 plug included)
M	minifast <sup>®</sup> male connector (1 plug included)

### Antenna

Code	Description
11 <sup>(1)</sup>	Still-pipe 1-in. antenna (deflector plate included)
12	Still-pipe 2-in. antenna (deflector plate included)

(1) Antenna and still-pipe 3000 mm included.

### Antenna plate

Code	Description	Antenna
2	2 in./DN 50 plate	1-in.
0	2 ½-in./DN 65 plate	1-in.
3	3-in./DN 80 plate	1-in., 2-in.

Code	Description	Antenna
4	4-in./DN 100 plate	1-in., 2-in.
6	6-in./DN 150 plate	2-in.
8	6-in./DN 200 plate	2-in.

**Antenna material**

Code	Description	Antenna
S	SST AISI 316L/EN 1.4436	1-in., 2-in.
X	Customer-specific, consult factory	1-in.

**Tank seal**

Code	Description
PV	PTFE with Viton fluoroelastomer O-rings
PK	PTFE with Kalrez perfluoroelastomer O-rings
QV	Quartz with Viton fluoroelastomer O-rings
QK	Quartz with Kalrez perfluoroelastomer O-rings

**Tank connection**

Code	Description	Antenna
ANSI flanges (SST AISI 316/316 L) - flat face		Antenna
2A	2 in. Class 150	1-in.
2B	2 in. Class 300	1-in.
3A	3 in. Class 150	1-in., 2-in.
3B	3 in. Class 300	1-in., 2-in.
4A	4 in. Class 150	1-in., 2-in.
4B	4 in. Class 300	1-in., 2-in.
6A	6 in. Class 150	2-in.
8A	8 in. Class 150	2-in.
EN flanges (SST EN 1.4404) - flat face		Antenna
HB	DN 50 PN40	1-in.
IA	DN 80 PN16	1-in., 2-in.
IB	DN 80 PN40	1-in., 2-in.
JA	DN 100 PN16	1-in., 2-in.
JB	DN 100 PN40	1-in., 2-in.
KA	DN 150 PN16	2-in.
LA	DN 200 PN16	2-in.
Other		Antenna
00	None	1-in., 2-in.
XX	Customer specific, consult factory	2-in.

**Antenna options**

Code	Description	Antenna
0	None (excluding still-pipe)	2-in.
1	Still-pipe, length 3.0 m (9.8 ft)	1-in., 2-in.
2	Still-pipe, length 6.0 m (19.7 ft)	2-in.
3	Still-pipe, length 9.0 m (29.5 ft)	2-in.
4	Still-pipe, length 12 m (39.4 ft)	2-in.
X	Customer specific, consult factory	1-in.

**Additional options****Safety certificate**

Requires Safety certification (SIS) code S.

Code	Description
QT	IEC 61508 certificate and FMEDA-data (printed copy)

**Calibration certificate**

Code	Description
Q4	Calibration certificate (printed copy)

**Material traceability certificate**

Not available for transmitter head sparepart.

Code	Description
Q8	Antenna material traceability certification per EN 10204 3.1

**Conformance certificate**

Code	Description
Q1	Certificate of conformance

**Overfill protection approval**

Code	Description
U1 <sup>(1)</sup>	TÜV/DIBt WHG approval for overfill protection
U2	SVTI approval for overfill protection (Switzerland)

(1) Requires one or more relay outputs in the Rosemount 2410 Tank Hub.

**Tag plate**

Code	Description
ST	Engraved SST tag plate (tag shall be submitted with order)

**Extended product warranty**

Rosemount extended warranties have a limited warranty of three or five years from date of shipment.

<b>Code</b>	<b>Description</b>
WR3	3-year limited warranty
WR5	5-year limited warranty

# Specifications

## General

### Instrument accuracy

<b>Parabolic, Still-pipe array, and LPG/LNG antennas</b>	± 1 mm (0.04 in.)
<b>Cone, and 1-in./2-in. still-pipe antennas</b>	± 2 mm (0.08 in.)

Instrument accuracy is under reference conditions. Reference conditions are: Measurement in test bench at Rosemount Tank Radar AB in Mölnlycke Sweden. Test bench is calibrated minimum yearly by an accredited laboratory: RISE Research Institutes of Sweden. Measuring range is up to 40 m (130 ft). Ambient temperature and humidity is close to constant during tests. Total uncertainty in test bench is below 0.15 mm (0.006 in.).

### Temperature stability

Typically < ± 0.5 mm (0.020 in.) in -40 to +70 °C (-40 to +158 °F)

### Fieldbus (standard)

FOUNDATION™ Fieldbus FISCO (Tankbus)

### Update time

New measurement every 0.3 s

### Repeatability

0.2 mm (0.008 in.)

### Maximum level rate

Up to 200 mm/s

### Metrology sealing possibility

Yes

### Installation considerations

See Rosemount 5900C [Reference Manual](#)

### Measurement principle

The FMCW-method (Frequency Modulated Continuous Wave) means that the transmitted radar signal has a linear frequency variation around 10 GHz. The reflection from the liquid surface has a slightly different frequency compared with the signal transmitted from the antenna when the reflection is received. The difference in frequency is directly proportional to the distance between the antenna and the liquid surface, and thereby also the liquid level. This technology enables a very accurate and stable measured value.

**Figure 3: Principle of FMCW Technology**

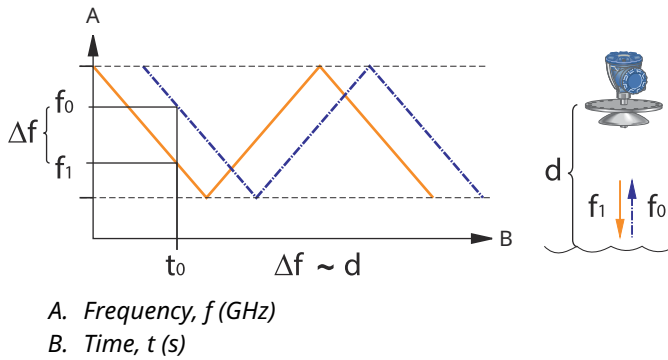

## Communication/Display/Configuration

### Output variables and units

- Level and ullage: meter, centimeter, millimeter, feet, or inch
- Level rate: meter/second, meter/hour, feet/second, feet/hour, inch/minute
- Signal strength: mV

### Configuration tools

Rosemount TankMaster WinSetup, Field Communicator

## FOUNDATION™ Fieldbus characteristics

### Polarity sensitive

No

### Quiescent current draw

51 mA

### Lift-off minimum voltage

9.0 VDC

### Device capacitance/inductance

See [Product certifications](#)

### Class (Basic or Link Master)

Link Master (LAS)

### Number of available VCRs

Maximum 20, including one fixed

### Links

Maximum 40

### Minimum slot time/maximum response delay/minimum intermessage delay

8/5/8

### Blocks and Execution time

**Table 1: Execution Time**

Block	Execution time
1 Resource block	N/A
5 Transducer blocks (Level, Register, Adv_Config, Volume, and LPG)	N/A
6 Analog Input (AI)	10 ms
2 Analog Output (AO)	10 ms
1 Proportional/Integral/Derivate (PID)	15 ms
1 Signal Characterizer (SGCR)	10 ms
1 Integrator (INT)	10 ms
1 Arithmetic (ARTH)	10 ms
1 Input Selector (ISEL)	10 ms
1 Control Selector (CS)	10 ms
1 Output Splitter (OS)	10 ms

For more information, see the FOUNDATION Fieldbus Blocks [Manual](#).

### Instantiation

Yes

### Conforming FOUNDATION Fieldbus

ITK 6

**Field Diagnostics support**

Yes

**Action support wizards**

Restart measurement, write protect device, factory reset - measurement configuration, start/stop device simulation, set as surface, reset statistics, change all modes, register/remove false echo, refresh echo peaks, pin verification, change vapor pressure, change vapor temperature.

**Advanced diagnostics**

Software, memory/database, electronics, internal communication, simulation, level correction, level measurement, ambient temperature, vapor pressure/temperature correction, LPG verification pin, and manual measurement values.

## Electric

### Tankbus cabling

0.5-1.5 mm<sup>2</sup> (AWG 22-16), twisted shielded pairs

### Power supply

FISCO: 9.0 - 17.5 VDC polarity insensitive (for example from Rosemount 2410 Tank Hub)

Entity: 9.0 - 30.0 VDC polarity insensitive

### Bus current draw

50 mA

### Microwave output power

< 1 mW

### Built-in Tankbus terminator

Yes (to be connected if required)

### Daisy chain possibility

Yes

## Mechanical

### Material selection

Emerson provides a variety of Rosemount products with various product options and configurations, including materials of construction that can be expected to perform well in a wide range of applications.

The product information presented is intended as a guide for the purchaser to make an appropriate selection for the application. It is the purchaser's sole responsibility to make a careful analysis of all process parameters (such as all chemical components, temperature, pressure, flow rate, abrasives, contaminants, etc.), when specifying product, materials, options, and components for the particular application. Emerson is not in a position to evaluate or guarantee the compatibility of the process fluid or other process parameters with the product, options, configuration, or materials of construction selected.

### Housing material and surface treatment

Polyurethane-coated die-cast aluminum

### Cable entry (connection/glands)

Two ½ - 14 NPT entries for cable glands or conduits. One metal plug to seal any unused port is enclosed in the transmitter delivery.

Optional:

- M20 x 1.5 conduit/cable adapter
- Cable glands in metal (½ - 14 NPT)
- 4-pin male eurofast connector or A size Mini 4-pin male minifast connector

### Total weight

**Table 2: Weight of Transmitter Head**

Transmitter head	Weight
Rosemount 5900C transmitter head	5.1 kg (11.2 lbs)

**Table 3: Weight With Antenna**

Transmitter head with antenna	Weight
Rosemount 5900C with cone antenna	Appr. 12 kg (26 lbs)
Rosemount 5900C with parabolic antenna	Appr. 17 kg (37 lbs)
Rosemount 5900C with still-pipe array antenna	Appr. 13.5-24 kg (30-53 lbs)
Rosemount 5900C with LPG/LNG antenna, 6-in. 150 psi	Appr. 30 kg (66 lbs)
Rosemount 5900C with LPG/LNG antenna, 6-in. 300 psi	Appr. 40 kg (88 lbs)

## Antennas

The Rosemount 5900C antennas have a drip-off design which for some versions also include inclined polished PTFE surfaces. Condensation on the antenna is minimized, and the radar signal remains strong. This results in maintenance free operation, high accuracy and reliability. There is always a suitable antenna for every tank type, tank opening and application:

- Parabolic
- Cone
- Still-pipe array
- LPG/LNG
- 1-in./2-in. still-pipe

## Transmitter head

The same transmitter head is used for all Rosemount 5900C antenna types, minimizing spare part requirements:

- The dual compartment transmitter housing, with electronics and cabling separated, can be replaced without opening the tank
- It is protected against lightning, moisture/rain, and has a surface protection against sulphur and salt spray atmospheres
- Electronics consists of one encapsulated unit.
- No need for re-calibration

## Environment

### Ambient operating temperature

-40 to +70 °C (-40 to +158 °F). Minimum start-up temperature is -50 °C (-58 °F)

### Storage temperature

-50 to +85 °C (-58 to +185 °F)

### Humidity

0-100% relative humidity

### Ingress protection

IP 66/67 and NEMA® 4X

### Vibration resistance

IEC 60770-1 level 1 and IACS UR E10 test 7

### Telecommunication

Compliance with:

- FCC 15B Class A, and 15C
- RED (EU directive 2014/53/EU) ETSI EN 302372; EN 50371
- IC (RSS210-5)

### Electromagnetic compatibility

- EMC (EU directive 2014/30/EU) EN 61326-1; EN 61326-3-1
- OIML R85:2008

### Transient / built-in lightning protection

According to IEC 61000-4-5, level 2 kV line to ground. Complies with IEEE 587 Category B transient protection and IEEE 472 surge protection.

### Low Voltage Directive (LVD)

LVD (EU directive 2014/35/EU) EN/IEC 61010-1

## Rosemount 5900C with parabolic antenna

### Operating temperature in tank

Maximum +180 °C (+356 °F) with FEP O-ring, or +230 °C (+445 °F) with Kalrez® O-ring

### Measuring range

0.8 to 40 m (2.6 to 130 ft) below flange

Possibility to measure 0.5 to 50 m (1.6 to 164 ft). Accuracy may be reduced. For longer measuring range, consult your local representative.

### Pressure range

Clamped/threaded: -0.2 to 0.2 bar (-2.9 to 2.9 psig)

Welded: -0.2 to 10 bar (-2.9 to 145 psig)

### Material exposed to tank atmosphere

Antenna: Material corresponds to AISI 316/316L and EN 1.4401 /1.4404

Sealing: PTFE

O-ring: FEP, or Kalrez®

### Antenna dimension

440 mm (17 in.)

### Manway size and installation

500 mm (20 in.) opening.

The parabolic antenna is installed on the manway cover by using the flange ball. It is designed for easy adjustment of the antenna inclination and orientation within the specified limits.

The flexible flange ball can be installed on both horizontal or inclined manways without any special arrangements.

### Tank connection

The gauge is clamped in a 96 mm (3.78 in.) diameter hole, or welded in a 117 mm (4.61 in.) diameter hole.

## Rosemount 5900C with cone antenna

### Operating temperature in tank

Max. +180 °C (+356 °F) with Viton® O-ring, or +230 °C (+445 °F) with Kalrez® O-ring

### Measuring range, accuracy, and cone dimensions

When selecting cone antenna dimension, it is generally recommended to use as large antenna diameter as possible. Standard cone antennas are available for 4-, 6- and 8-in. tank openings. The 4- and 6-in. cones can be extended to fit long tank nozzles.

Level accuracy is up to ±2 mm (0.08 in.) for 8-in. cone antennas. For 4- and 6-in. cone antennas accuracy depends on installation conditions.

### Measuring range

8-in. Cone: 0,8 to 20 m (2.6 to 65 ft) below flange. (Possibility to measure 0,4 to 30 m (1.3 to 100 ft). Accuracy may be reduced.)

6-in. Cone: 0.8 to 20 m (2.6 to 65 ft) below flange. (Possibility to measure 0.3 to 25 m (1 to 80 ft). Accuracy may be reduced.)

4-in. Cone: 0.8 to 15 m (2.6 to 50 ft) below flange. (Possibility to measure 0.2 to 20 m (0.7 to 65 ft). Accuracy may be reduced.)

### Material exposed to tank atmosphere

Antenna: SST AISI 316L/EN 1.4436

Sealing: PTFE, or Quartz

O-ring: Viton®, or Kalrez®

### Pressure/temperature rating

**Figure 4: Temperature and Maximum Pressure Relation**

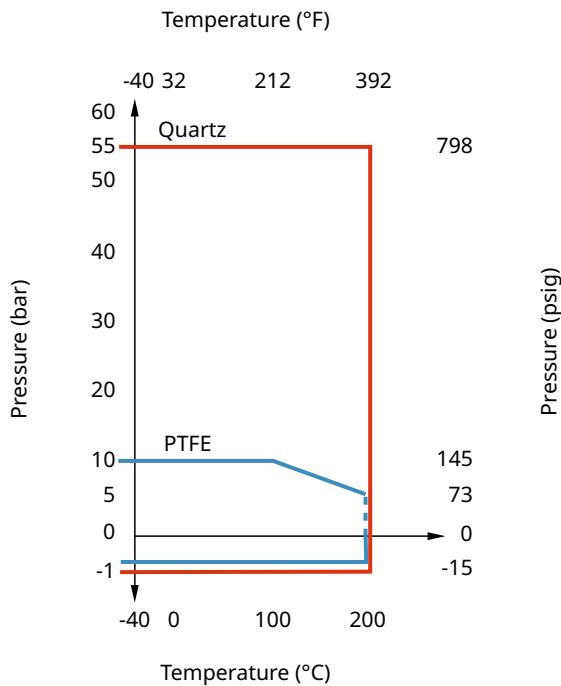

## Rosemount 5900C with still-pipe array antenna

### Operating temperature in tank

-40 to 120 °C (-40 to 248 °F) with FMVQ O-ring, -20 to 120 °C (-4 to 248 °F) with Kalrez® O-ring

### Measuring range

0.8 to 40 m (2.6 to 130 ft) below flange

The minimum range can be extended to 0.5 m (1.6 ft) with slightly reduced accuracy. For longer measuring range, consult your local representative.

### Pressure range

Fixed version: -0.2 to 2 bar (-2.9 to 29 psig) at 20 °C (68 °F).

Hinged hatch version: -0.2 to 0.5 bar (-2.9 to 7.2 psig) for 5 to 8-in. pipes.

-0.2 to 0.25 bar (-2.9 to 3.6 psig) for 10 and 12-in. pipes.

### Material exposed to tank atmosphere

Antenna: Polyphenylenesulphide (PPS)

O-ring: FMVQ, or Kalrez®

Flange: Material corresponds to AISI 316/316L and EN 1.4401 /1.4404

Hinged hatch version, O-ring: Viton®

### Still-pipe dimensions

5-, 6-, 8-, 10- or 12 in.

### Tank connection

5 in. hole pattern according to ANSI 5 in. Class 150

6 in. hole pattern according to ANSI 6 in. Class 150 / DN 150 PN 16

8 in. hole pattern according to ANSI 8 in. Class 150 / DN 200 PN 10

10 in. hole pattern according to ANSI 10 in. Class 150 / DN 250 PN 16

12 in. hole pattern according to ANSI 12 in. Class 150

## Rosemount 5900C with LPG/LNG antenna

### Operating temperature at ball valve

-55 to 90 °C (-67 to 194 °F)

### Operating temperature in tank

-170 to 90 °C (-274 to 194 °F)

### Measuring range

1.2 to 40 m (3.9 to 130 ft) below flange

Possibility to measure 0.8 to 60 m (2.6 to 200 ft). Accuracy may be reduced. For longer measuring range, consult your local representative.

### Pressure range

-1 to 25 bar (-14.5 to 365 psig).

Note! Flanges may have higher pressure rating than 25 bar, but maximum tank pressure is still 25 bar.

### Pressure sensor (option)

Rosemount 2051, pressure sensor range 0-55 bar. For other pressure range contact factory. Rosemount 2051 is available with various hazardous location certifications.

For more information see the Rosemount 2051 [Product Data Sheet](#) and [Quick Start Guide](#).

### Material exposed to tank atmosphere

Antenna and flange: Material corresponds to AISI 316/316L and EN 1.4401 /1.4404

Sealing: PTFE

### Still-pipe dimension compatibility

Antenna choices are available for the following still-pipe dimensions:

- 4 in Schedule 10 or 40
- 6 in Schedule 10 or 40
- DN100
- DN150

### Flange size and rating

1.5 in. Class 300

2 in. Class 150/300

3 in. Class 150/300

4 in. Class 150/300

6 in. Class 150/300

8 in. Class 150/300

DN 100 PN40

DN 150 PN40

DN 200 PN25

DN 200 PN40

### Pressure seal

The pressure seal includes a double-block function, consisting of a PTFE seal and a fire-proof ball valve. A pressure sensor enables correction due to vapor for best measurement performance.

**Verification possibility**

A patented reference device function enables measurement verification with the tank in service. A verification pin mounted in a still-pipe hole, and a deflection plate with a verification ring at the lower still-pipe end provide reference echoes at fixed pre-defined distances.

## Rosemount with 1- and 2-in. still-pipe antennas

### Operating temperature in tank

Max. +180 °C (+356 °F) with Viton® O-ring, or +230 °C (+445 °F) with Kalrez® O-ring

### Measuring range

1-in. still-pipe antenna: 0.2 to 3 m (0.7 to 9.8 ft.) below flange.

2-in. still-pipe antenna: 0.2 to 12 m (0.7 to 39 ft.) below flange.

(Possibility to measure longer ranges. For more information, contact your local Emerson representative.)

### Material exposed to tank atmosphere

Antenna: SST 316L

Sealing: PTFE, or Quartz

O-ring: Viton®, or Kalrez®

### Pressure/temperature rating

Figure 5: Temperature and Maximum Pressure Relation

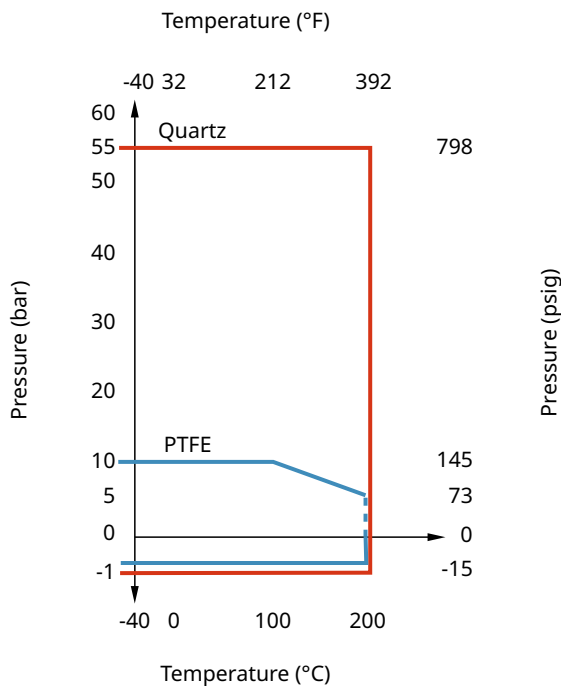

## Product certifications

See the Rosemount 5900C [Product Certifications](#) document for detailed information on the existing approvals and certifications.

# Dimensional drawings

Figure 6: Dimensions of Rosemount 5900C with Parabolic Antenna

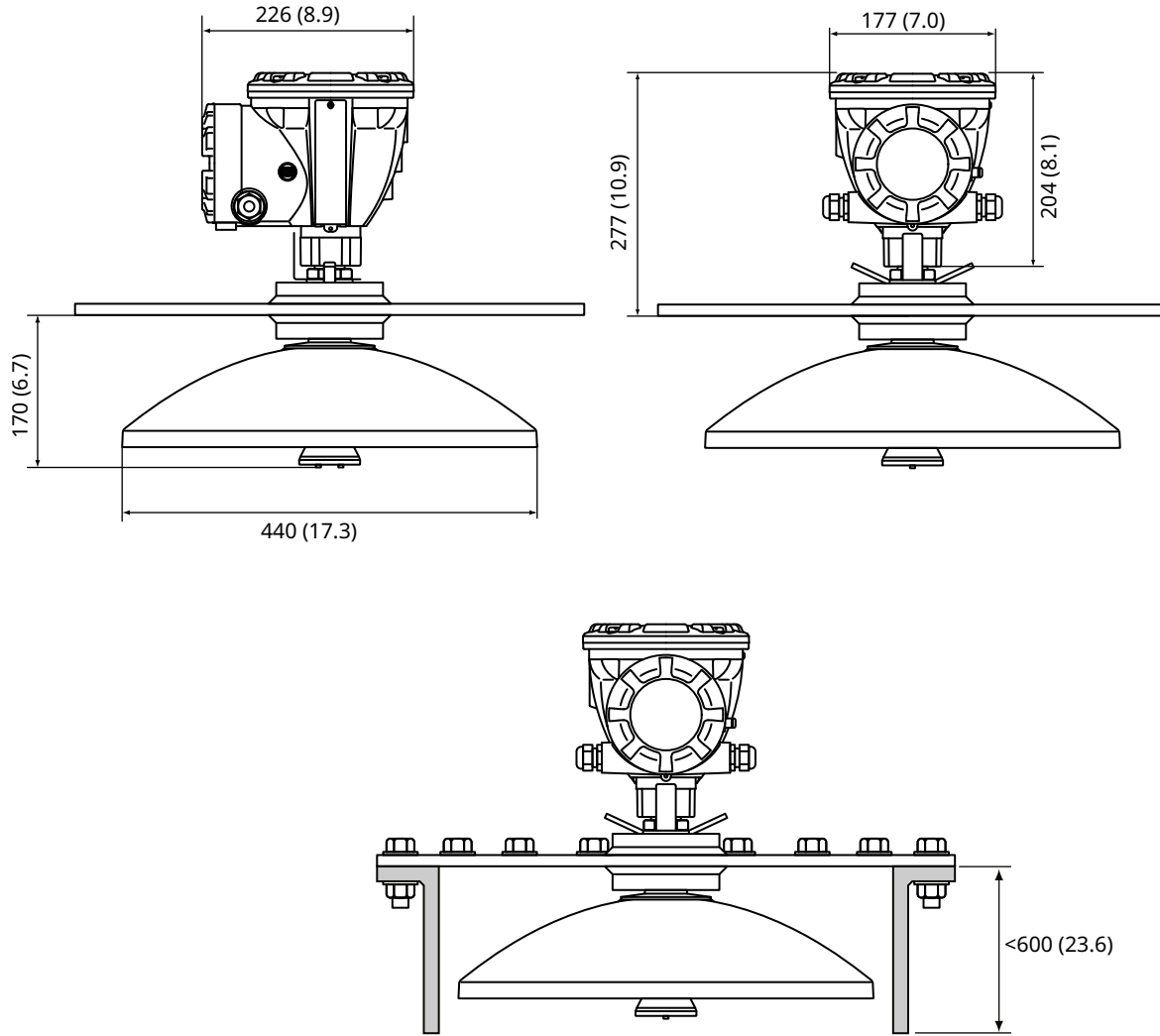

Dimensions are in millimeters (inches).

**Figure 7: Dimensions of Rosemount 5900C with Cone Antenna**

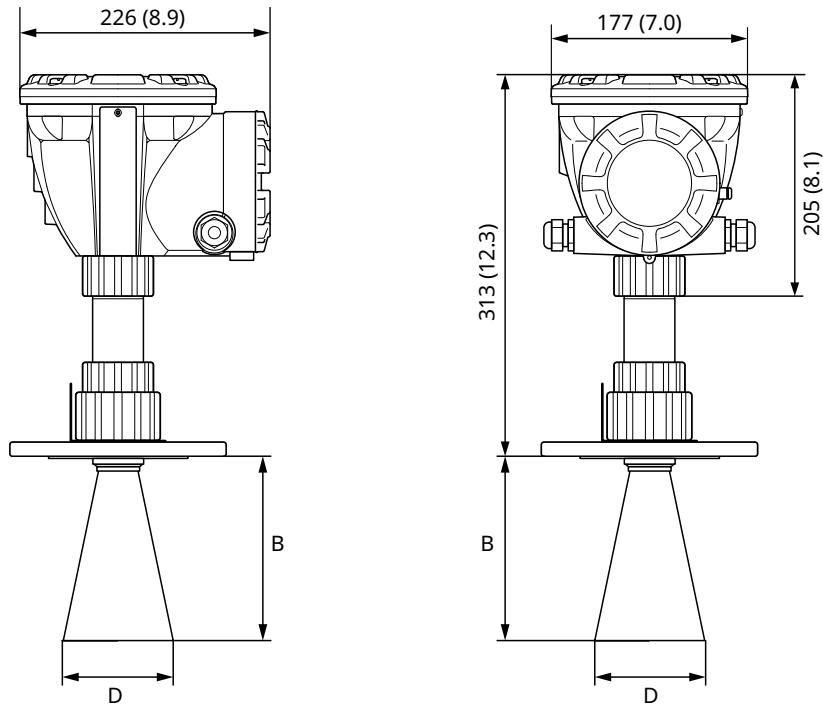

Dimensions are in millimeters (inches).

**Table 4: Available Sizes for Cone Antenna, millimeters (inches)**

Antenna size	D	B
4 in. / DN100	93 (3.7)	150 (5.9)
6 in. / DN150	141 (5.6)	250 (10.2)
8 in. / DN200	189 (7.4)	370 (14.6)

Figure 8: Dimensions of Rosemount 5900C with Still-Pipe Array Antenna

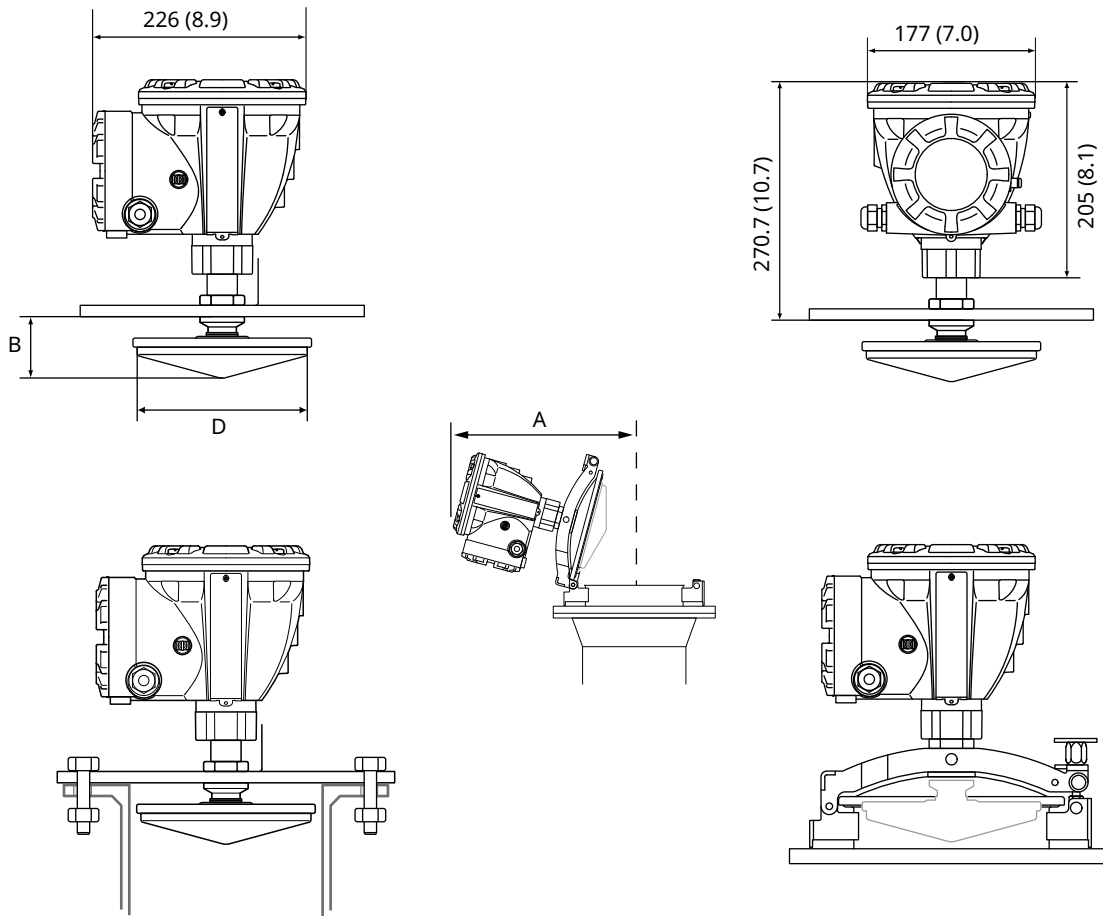

Dimensions are in millimeters (inches).

Table 5: Available sizes for Still-Pipe Array Antenna, millimeters (inches)

Antenna size	D	B	A
5 in. / DN125	120 (4.7)	56 (2.2)	431 (17.0)
6 in. / DN150	145 (5.7)	59 (2.3)	431 (17.0)
8 in. / DN200	189 (7.4)	65 (2.6)	441 (17.4)
10 in. / DN250	243 (9.6)	73 (2.9)	450 (17.7)
12 in. / DN300	293 (11.5)	79 (3.1)	450 (17.7)

**Figure 9: Dimensions of Rosemount 5900C with LPG/LNG Still-Pipe Antenna**

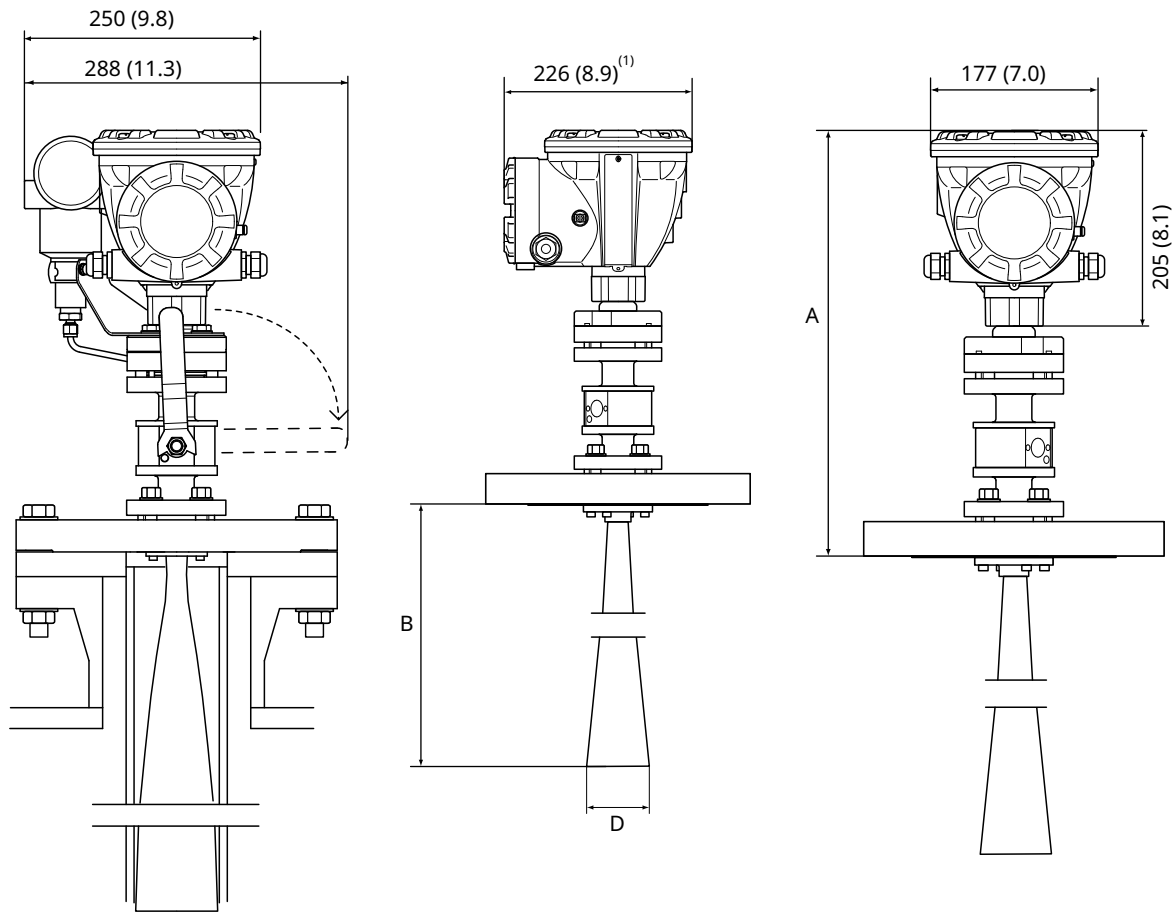

A. Approximately 452 (17.8), depending on flange type

1. 302 (11.9) with pressure transmitter

Dimensions are in millimeters (inches).

**Table 6: Available sizes for LPG/LNG Still-Pipe antenna, millimeters (inches)**

Antenna size	D	B
4 in. Schedule 10	107 (4.2)	752 (29.6)
4 in. Schedule 40	101 (4.0)	534 (21.0)
6 in. Schedule 10	159 (6.3)	1375 (54.1)
6 in. Schedule 40	153 (6.0)	1314 (51.7)
DN100	99 (3.9)	502 (19.8)
DN150	153 (6.0)	1314 (51.7)

Figure 10: Dimensions of Rosemount 5900C with 1- and 2-in. Antenna

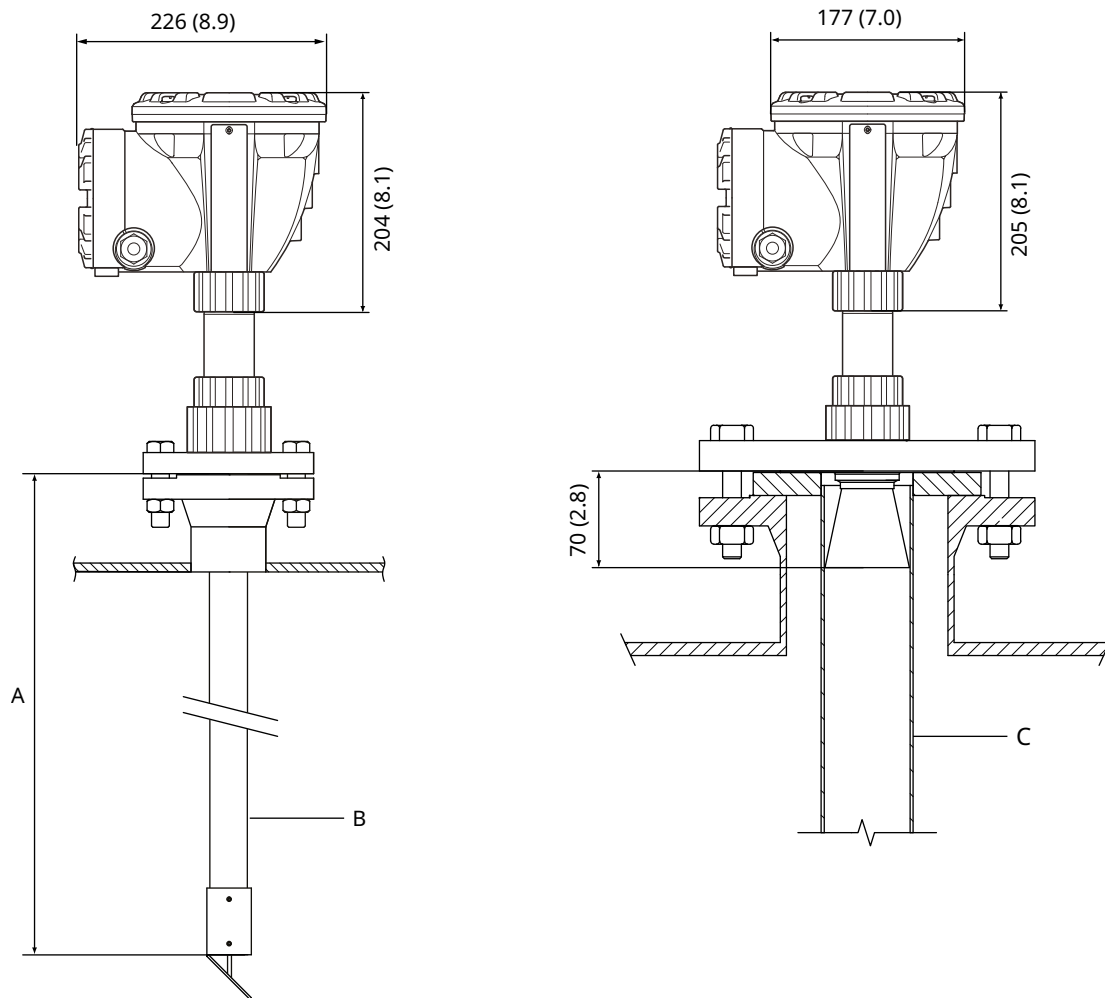

- A. Standard length 3000 (118.1)
- B. 1-in. still-pipe antenna
- C. 2-in. still-pipe antenna

Dimensions are in millimeters (inches).







For more information: [Emerson.com/global](https://emerson.com/global)

©2025 Emerson. All rights reserved.

Emerson Terms and Conditions of Sale are available upon request. The Emerson logo is a trademark and service mark of Emerson Electric Co. Rosemount is a mark of one of the Emerson family of companies. All other marks are the property of their respective owners.

**ROSEMOUNT™**

